

Carbon Fiber Data Base: Data Base
Review and Assessment of Carbon
Fiber Release into the Environment

Bionetics Corp.
Hampton, VA

Prepared for

Industrial Environmental Research Lab
Cincinnati, OH

19951228 084

Mar 82

DTIC QUALITY

DISTRIBUTION STATEMENT A
Approved for public release;
Distribution Unlimited

DEPARTMENT OF DEFENSE
POLYMER TECHNICAL EVALUATION CENTER
AERONAUTICAL ENGINEERING DIVISION

U.S. DEPARTMENT OF COMMERCE
National Technical Information Service

NTIS®

19951228 084

DISCLAIMER NOTICE



THIS DOCUMENT IS BEST QUALITY AVAILABLE. THE COPY FURNISHED TO DTIC CONTAINED A SIGNIFICANT NUMBER OF PAGES WHICH DO NOT REPRODUCE LEGIBLY.

EPA 600/2-82-038
March 1982

FB82-236027

CARBON FIBER DATA BASE
Data Base Review and Assessment of
Carbon Fiber Release into the Environment

by

The Bionetics Corporation
20 Research Drive
Hampton, Virginia 23666

Contract 68-03-2848

Project Officer

Richard A. Carnes
Industrial Pollution Control Division
Industrial Environmental Research Laboratory
Cincinnati, Ohio 45268

September, 1980

REPRODUCED BY
NATIONAL TECHNICAL
INFORMATION SERVICE
U.S. DEPARTMENT OF COMMERCE
SPRINGFIELD, VA. 22161

INDUSTRIAL ENVIRONMENTAL RESEARCH LABORATORY
OFFICE OF RESEARCH AND DEVELOPMENT
U.S. ENVIRONMENTAL PROTECTION AGENCY
CINCINNATI, OHIO 45268

TECHNICAL REPORT DATA (Please read instructions on the reverse before completing)		
1. REPORT NO. EPA-600/2-82-038	2. ORD Report	3. RECIPIENT'S ACCESSION NO. PB87 236027
4. TITLE AND SUBTITLE CARBON FIBER DATA BASE Review and Assessment of Carbon Fiber Release into the Environment	5. REPORT DATE March 1982	
	6. PERFORMING ORGANIZATION CODE	
7. AUTHOR(S) The Bionetics Corporation	8. PERFORMING ORGANIZATION REPORT NO. 79-57-1 Final	
9. PERFORMING ORGANIZATION NAME AND ADDRESS The Bionetics Corporation 20 Research Drive Hampton, Virginia 23666	10. PROGRAM ELEMENT NO. 1AD712	
	11. CONTRACT/GRANT NO. 68-03-2848	
12. SPONSORING AGENCY NAME AND ADDRESS Municipal Environmental Research Laboratory--Cin., OH Office of Research and Development U.S. Environmental Protection Agency Cincinnati, Ohio 45268	13. TYPE OF REPORT AND PERIOD COVERED Final, Aug. 13, 79-Sept. 30, 80	
	14. SPONSORING AGENCY CODE EPA/600/12	
15. SUPPLEMENTARY NOTES R.A. Carnes, Project Officer		
16. ABSTRACT This study addressed the eventual disposal of carbon fiber composites in municipal waste streams. A survey of current literature presents the effects of fires on carbon fiber composites, the effects of airborne carbon fibers including incidents of electrical failures, applications of composites, the direction of current research and the present manufacturers of both fiber and composites. A bibliography lists the pertinent publications and data sources. Reviews of Federal Carbon Fiber Programs include those concerned with fire accidents, the effects of airborne fibers and the development of measurement techniques for airborne carbon fibers. The sources of carbon fiber composites entering municipal waste streams are identified, the capabilities of solid waste disposal techniques have been evaluated and includes an estimate for a potential release of airborne carbon fibers from municipal incinerators. The Federal Agencies involved in carbon fiber studies are listed together with their coordinator or principal investigators. Bibliography List of Federal Agencies involved with Carbon Fibers		
17. KEY WORDS AND DOCUMENT ANALYSIS		
a. DESCRIPTORS	b. IDENTIFIERS/OPEN ENDED TERMS	c. COSATI Field/Group
Carbon Fibers Graphite Composites Refuse Disposal	Airborne Fibers Electrical Hazards Disposal Techniques	11.D 11.E
18. DISTRIBUTION STATEMENT Release to Public	19. SECURITY CLASS (This Report) Unclassified	21. NO. OF PAGES 244
	20. SECURITY CLASS (This page) Unclassified	22. PRICE

NOTICE

THIS DOCUMENT HAS BEEN REPRODUCED FROM THE BEST COPY FURNISHED US BY THE SPONSORING AGENCY. ALTHOUGH IT IS RECOGNIZED THAT CERTAIN PORTIONS ARE ILLEGIBLE, IT IS BEING RELEASED IN THE INTEREST OF MAKING AVAILABLE AS MUCH INFORMATION AS POSSIBLE.

DISCLAIMER

This report has been reviewed by the U.S. Environmental Protection Agency and approved for publication. Approval does not signify that the contents necessarily reflect the views and policies of the U.S. Environmental Protection Agency, nor does mention of trade names or commercial products constitute endorsement or recommendation for use.

FOREWORD

When energy and material resources are extracted, processed, converted, and used, the related polluttional impacts on our environment and even on our health often require that new and increasingly more efficient pollution control methods be used. The Industrial Environmental Research Laboratory-Cincinnati (IERL-Ci) assists in developing and demonstrating new and improved methodologies that will meet these needs both efficiently and economically.

This report compiles current data and descriptive materials on production, use and disposal mechanisms of carbon fiber. It is intended to serve as a state-of-the-art information base for use in further research into the potential hazards of carbon fiber disposal and the development of appropriate pollution control technology. The report will be of interest to those concerned with carbon fiber in general, and with the environmental impacts of this material in particular. Further information on carbon fiber disposal research may be obtained through the Alternate Energy Sources Branch of the Energy Pollution Control Division of IERL-Ci.

David G. Stephan
Director
Industrial Environmental Research Laboratory
Cincinnati

ABSTRACT

The objective of the effort described in this document was to determine the potential environmental impacts arising from the introduction of carbon fiber composite materials into American commerce. The program was conducted in response to seven assigned task areas. Each area was developed in such a way as to focus on the effects arising from the disposal of carbon fiber materials, particularly those items which might enter municipal waste streams.

Three of the tasks were concerned with existing information, in order to develop an information base for further efforts. A Literature Search of recently published material extracted pertinent information in the following areas: release of airborne carbon fibers from incidents involving fires; current and developing applications of carbon fiber composites; research; properties of materials; and locations of manufacturers of carbon fibers or composites. Concurrently, two of the task responses took the form of a review and reporting of both completed and on-going efforts by Federal Departments and Agencies. This effort was related to the assigned Risk Assessments conducted by six Federal departments, as well as to the actions taken by four other Federal Agencies.

Three task responses were directly related to the problem of disposing of carbon fibers or composites. Drawing upon the information developed in the first two tasks, data collected during on-site visits, surveys, and available expertise, task responses were developed in the following areas: characterization of typical life cycles for carbon fiber composites in various applications; analysis of disposal techniques and, in particular, of those techniques which may be used for incineration of municipal wastes; and estimation of the potential electrical and health effects which could result from the introduction of carbon fiber composites into municipal waste streams.

The seventh task response is directed toward effective dissemination of information among the various Federal agencies and departments concerned with carbon fiber composites. An inter-agency data exchange plan was developed, and the appropriate Directory and Distribution Lists are included in this document.

This report was submitted in fulfillment of Contract No. 68-03-2848 by the Bionetics Corporation under sponsorship of the U.S. Environmental Protection Agency. This report covers the period from August 13, 1979 to September 12, 1980, and work was completed on September 12, 1980.

CONTENTS

Foreword iii

Abstract. iv

Figuresviii

Tables. x

1.0 Executive Summary. 1

 1.1 Introduction. 1

 1.2 Conclusions 2

 1.3 Recommendations 4

 1.4 Organization of the Report (Response to Tasks). 5

2.0 Literature Search Task I 6

 2.1 Task Requirements 6

 2.2 Response to the Task. 6

 2.3 Hazards, Fire-Release 17

 2.4 Applications. 38

 2.5 Research. 59

 2.6 Properties of Materials 71

 2.7 Fiber and Composite Manufacturers 77

3.0 Risk Assessments 84

 3.1 Overview of Risks 84

 3.2 Summary of Risk Assessment Programs 86

 3.3 Risk Assessment Program, NASA 87

 3.4 Risk Assessment Program, Department of
 Transportation. 101

 3.5 Risk Assessment Program, Department of Energy . 108

 3.6 Risk Assessment Program, U.S. Department of
 Labor 112

 3.7 Risk Assessment Program, Department of Health
 and Human Services. 115

 3.8 Risk Assessment Program, Department of Defense. 120

CONTENTS (Continued)

4.0 Carbon Fiber Related Programs	128
4.1 Overview of Programs	128
4.2 Outline of Continuing Programs	131
4.3 Program for the U.S. Environmental Protection Agency - Environmental Sciences Research Laboratory	132
4.4 Program for the Federal Aviation Administration	141
4.5 Program for the Federal Emergency Management Agency	144
5.0 Life Cycle Evaluations of Carbon Fibers in Commerce	149
5.1 General	149
5.2 Life Cycle for Carbon Fiber Composites in Transport Aircraft	151
5.3 Life Cycle Considerations for Carbon Fiber Composites in Automotive Applications	156
5.4 Life Cycle Considerations for Carbon Fiber Composites in Sporting Goods	162
5.5 Life Cycle Considerations for Carbon Fiber Composites in Medical Applications (Prosthetic and Orthotic Devices)	166
6.0 Evaluation of Disposal Techniques	170
6.1 General	170
6.2 Criteria for Evaluation of Disposal Techniques	170
6.3 Bulk Disposal	176
6.4 Combustion/Oxidation Disposal	177
6.5 Results	193
6.6 Recommendations	202
7.0 Carbon Fiber Releases into the Environment	205
7.1 Environmental Criteria and Considerations	205
7.2 Projections of Emission Effects	210

CONTENTS (Continued)

8.0 Interagency Data Exchange.	214
8.1 Introduction.	214
8.2 Distribution of Carbon Fiber Related Information and Data.	214
8.3 Generation of Carbon Fiber Related Information and Data.	215
Appendix.	218
A. Directory and Locator.	218

FIGURES

<u>Number</u>		<u>Page</u>
2-1	Carbon Fiber and Composite Production Flow Chart	8
2-2	Mass Balance For Carbon Fibers from Burned Composites.	23
2-3	Average Exposure to Failure for Vulnerable Equipment	27
2-4	Transfer Functions for Air Filters Compared to ASHRAE Dust Spot Efficiency Ratings	31
2-5	Candidate Automotive Application For Carbon Fiber Based Composites.	40
2-6	Carbon Fiber Composite Valve For Handling Corrosive Liquids	43
2-7	Carbon Fiber Based Composite Application to an Artificial Hip Joint Implant.	46
2-8	Application of Carbon Fiber Based Composites to the U.S. Navy F-18 Fighter.	51
2-9	Carbon Fiber Nestable Columns For Building Large Scale Structures.	54
2-10	The Carbon Fiber Industry By EPA Region	78
3-1	NASA Program Plan, Graphite Fiber Risk Assessment .	100
4-1	EPA-ESRL Carbon Fiber Fiber Program Schedule. . . .	140
5-1	Carbon Fiber Composite Life Cycle in Aircraft . . .	152
5-2	Carbon Fiber Composite Life Cycle in Automotive Applications.	157
5-3	Carbon Fiber Compoiste Life Cycle in Sporting Goods	163

FIGURES (Continued)

<u>Number</u>		<u>Page</u>
5-4	Carbon Fiber Composite Life Cycle in Medical Applications	167
6-1	Iso-thermogravimetric analyses of "AS" Carbon Fibers at 1000° C (1800°F)	174
6-2	Conventional Mass-Fired Incinerator.	181
6-3	Multiple-Hearth Incinerator.	185
6-4	Fluid Bed Incinerator.	186
6-5	Wet Air Oxidation.	192
A-1	Master Distribution List	231

TABLES

<u>Number</u>		<u>Page</u>
1-1	Report Organization (Response to Tasks)	5
2-1	Fire-Release Fiber Categories	21
2-2	Summary of Carbon Fiber Release Data for Electrical Hazard Lengths	24
2-3	Summary of Incidents	34
2-4	Summary of Principal Aircraft Applications for Carbon Fiber Composites	48
2-5	Areas of Research	59
2-6	Comparison of Research Efforts	60
2-7	Overseas Research Efforts	62
2-8	Comparison of Carbon Fiber, Aluminum and Steel . .	73
2-9	Fiber Properties as Manufactured	74
2-10	Properties of Resin Matrix Materials	76
2-11	Secondary Carbon Fiber Composite Manufactured by EPA Region	80
4-1	Results from Carbon Fiber Surveys Conducted by U.S. Department of Commerce	129
5-1	Life Cycle Considerations for Carbon Fiber Composites in Transport Aircraft	153
5-2	Life Cycle Considerations for Carbon Fiber Composites in Automotive Application	158
5-3	Life Cycle Considerations for Carbon Fiber Composites in Sporting Goods Application	164
5-4	Life Cycle Considerations for Carbon Fiber Composites in Medical Applications (Prosthetic and Orthotic Devices)	164

TABLES (Continued)

<u>Number</u>		<u>Page</u>
6-1	20 Minute Propane Burn Results.	172
6-2	Results of Evaluation For In-Place Municipal Disposal Techniques	194
6-3	Results of Evaluation For Techniques With Potential For Application to Municipal Waste Streams	198
6-4	Results of Evaluation For Special Purpose Disposal Techniques	201
7-1	List of Symbols	206
7-2	Summary of Conditions for Fire-Released by Incineration.	207
7-3	Distribution of Airborne Carbon Fibers Released by Incineration	209
7-4	Television Failure Rates.	211
8-1	Interagency Information Exchange Distribution List.	216
8-2	Interagency Information Generation List	217
A-1	Interagency Information Exchange Distribution List.	229
A-2	Interagency Information Genreation List	230

1.0 EXECUTIVE SUMMARY

1.1 INTRODUCTION

The development of carbon fiber-based composite materials for applications to aircraft and space equipment has resulted in a companion growth of applications to sporting goods and industrial equipment. The combination of light weight and high strength are making these composites attractive to the automobile industry. Some carbon fiber composites will find their way into municipal waste streams; therefore, an understanding of these materials relative to the present disposal technology is required. The preparation of a data base as part of such an understanding must consider the implications and results of the 1972 incident at Fostoria, Ohio. The accidental incineration of raw carbon fibers led to the fallout of conductive fibers; electrical shorts and damage to circuit elements in the surrounding distribution system were experienced as far as six miles from the point of incineration. This incident, in conjunction with other information concerning the electrical characteristics of graphitized carbon fiber, gave rise to a coordinated National Action Plan involving a number of Federal agencies.

The data and studies contained in this report respond to the particular needs of the EPA for development of methods for disposing of carbon fiber composites moving in municipal waste streams. The effort began with a search and review of recently published literature and included a summary of the assigned Federal carbon fiber programs. The effort continued with evaluations of life cycles for carbon fibers in commerce, studies of incinerators and disposal techniques, and an estimate of the potential release which could accompany an uncontrolled incineration of carbon fiber composites. In order to facilitate the continuing interchange of information related to carbon fibers, an Interagency Data Exchange plan has been developed. The use of this plan will allow the rapid distribution and sharing of materials being developed by various Federal agencies.

1.2

CONCLUSIONS

The benefits gained from the use of carbon fiber composites over a wide range of applications will encourage the rapid maturation of the technology for production, fabrication and inspection of these materials. These developments will result in a limited input of carbon fiber composite material into municipal waste streams. Although composites will be used in aerospace, medical, and industrial applications, the materials which will enter municipal waste streams will be derived almost entirely from consumer (sporting goods) and automotive products.

Based on the data derived for the Risk Assessments by various Federal agencies, airborne carbon fibers present a small, definable risk to electrical equipment. Any health hazard associated with small diameter, respirable carbon fibers is undefined. Unless some effect specifically attributable to carbon fibers appears, these fibers will be treated as an increment in the present population of ambient fibrous aerosols.

Fully cured carbon fiber composites themselves present no apparent electrical risk. An exposure to fire or heat which burns away the resins in the binder will result in the release of airborne single, electrically conductive carbon fibers. These fibers can find their ways into items of electrical equipment and have the potential to cause malfunctions. For a given exposure to such fibers, the number of electrical failures can be described in terms of mathematical probabilities.

Free carbon fibers can also result from the mechanical agitation or mishandling of either virgin fiber material or uncured impregnated material. This second type of release is possible during fiber manufacture, impregnation operations, part fabrication, and scrap disposal. Thus, the concerns for carbon fiber releases are centered on incineration of any carbon fiber material and the manufacture of carbon fibers or composites.

Over the short term, the real concern is during manufacture. Because fabrication technology is still developing, a disproportionate amount of scrap is likely to be produced. Pre-impregnated material has a limited shelf life, and poor inventory control could result in the need to dispose of this uncured material. Small manufacturers of specialty items may not be fully cognizant of the risks associated with airborne carbon fibers. As a consequence, through either ignorance or indifference an uncontrolled burning of scrap still could precipitate an

incident reminiscent of Fostoria. The results of on-site experience indicate that the chopping or shredding of uncured material can result in a significant airborne release of single fibers.

At the present, the only method, which industry has found acceptable for disposal of carbon fibers, impregnated materials, or composites is by landfill. Over the next decade, an increasing amount of carbon fiber composite material is likely to be introduced into municipal waste streams. A portion of this will be incinerated, and the effectiveness of present and project incineration techniques in limiting the emission of conductive fibers is not sufficiently documented. In particular, the effectiveness of exhaust gas particle removal systems (electrostatic precipitators, bag houses, wet scrubbers) in limiting the emission of carbon fibers is not yet defined.

1.3 RECOMMENDATIONS

Evaluation of the material contained in this report has led to the following recommendations for action:

- A. Quantify the effectiveness of exhaust gas particle removal systems in limiting the release of free carbon fibers from incinerators.
- B. Measure airborne carbon fiber emissions from pre-processing operations presently used in municipal incineration facilities.
- C. Characterize mass-fired two-stage burn incinerators relative to carbon fiber composite disposal in order to optimize their effectiveness.
- D. Determine the need for dedicated or semi-dedicated facilities for the disposal of production scrap, virgin fiber or uncured impregnated material.

These recommendations are expanded and detailed in Section 6.6 of this report. Specific steps and suggested methods for carrying out the recommendations are included in that section.

1.4 ORGANIZATION OF THE REPORT (RESPONSE TO TASKS)

This report has been developed in response to the Tasks outlined in the Statement of Work of Request for Proposal Cl-79-0085. The order of presentation of the sections of the report, and the specific task to which each section responds, is as follows:

TABLE 1-1 REPORT ORGANIZATION (RESPONSE TO TASKS)

<u>SECTION</u>	<u>TITLE</u>	<u>TASK</u>
2.0	Literature Search	1
3.0	Risk Assessments	2
4.0	Carbon Fiber Related Programs	3
5.0	Life Cycle Evaluations of Carbon Fibers in Commerce	6
6.0	Evaluation of Disposal Techniques	5
7.0	Carbon Fiber Release into the Environment	4, 6
8.0	Interagency Data Exchange	7

Throughout the report, and within each section and subsection, the objective has been to organize and report the material in a manner consistent with the overall objectives of the project. The primary concern has been to clearly identify the potential impacts resulting from the use of carbon fibers and composites. The potential for airborne release of free carbon fibers, particularly through incineration, has been emphasized throughout.

2.0 LITERATURE SEARCH

2.1 TASK REQUIREMENTS

The Task definition for the Literature Search requested a review of both domestic and foreign carbon fiber literature with particular attention to:

- o Past adverse effects resulting from the release of airborne fibers.
- o Mechanisms and methods for controlling carbon fibers in the environment.
- o Problems associated with handling and disposing of carbon fiber-bearing materials.
- o Potential applications of carbon fibers in various market places, and the environmental problems that could result.

2.2 RESPONSE TO THE TASK

The response to the Task involved both the Literature Search itself and a synthesis of the information contained in the literature. For presentation purposes, this response has been organized into the following sections:

- 2.2.1 Conduct of the Literature Search
- 2.2.2 Overview of Carbon Fiber Utilization in Composites
- 2.2.3 Summary of Results

2.2.1 CONDUCT OF THE LITERATURE SEARCH

Many of the data requirements which arose during the Risk Assessment Program at the NASA-Langley Research Center coincided with the needs of the Literature Search. Therefore, the Literature Search received access to the NASA/RECON computerized data search capability. The first review of data on carbon fibers showed approximately 3,000 publications, with only a few (~25) addressing the problems of fire-released airborne fibers and their adverse effects. A further review showed that

recent data (1975 and later) contained all the pertinent information. On this basis, the Literature Search involved approximately 2,000 items and focused on those carbon fibers intended for use in structural composites. These fibers have the potential for release from a fire as electrically conductive airborne fibrous aerosols. Such fibers exhibit some degree of graphitic microstructure. In their applications to composites, the process of curing the matrix material does not change the microstructure of the fibers. Carbon fiber applications with metal matrices or with materials which change the properties of the fibers by high temperature carbonization of the matrix do not show any mechanism for release as fibrous aerosols; therefore, these areas of application were not included in the literature reviewed.

The computerized printouts and supplementary literature totaled more than 1,500 entries, which were reviewed for content. These were expanded by manual searches of periodical summaries and science abstract compilations. Extraction from periodicals drew from the LaRC and other libraries with extensive periodical files, such as those of the College of William and Mary and the Virginia Polytechnic Institute and State University. Other references appeared as publications in support of the NASA-LaRC Risk Analyses. These later items are currently entering the computerized systems.

In some areas, for example, applications to specific products, the literature showed many articles pertaining to a single effort. Typical is the research program of the Ford Motor Company aimed at applying carbon fibers to automobiles. The trade oriented publications (e.g., Iron Age, Business Week) made partial reports of the program. The complete descriptions appeared as publications by the Society of Automobile Engineers. The descriptions of applications to aircraft show similar patterns, usually with a publication by a technical society (e.g., symposium proceedings by the Society for the Advancement of Material and Process Engineering) as the definitive source.

2.2.2 OVERVIEW OF CARBON FIBER UTILIZATION IN COMPOSITES

In order to place the Literature Search results in perspective, an overview of the process for the production of both carbon fibers and carbon fiber composites is required. Figure 2-1 shows the flow of events which presently leads from raw material to a fabricated carbon fiber composite. The following explanations and comments will aid in defining relevant terms and clarifying some concepts appropriate to an understanding of the potential impacts of carbon fibers entering municipal waste streams.

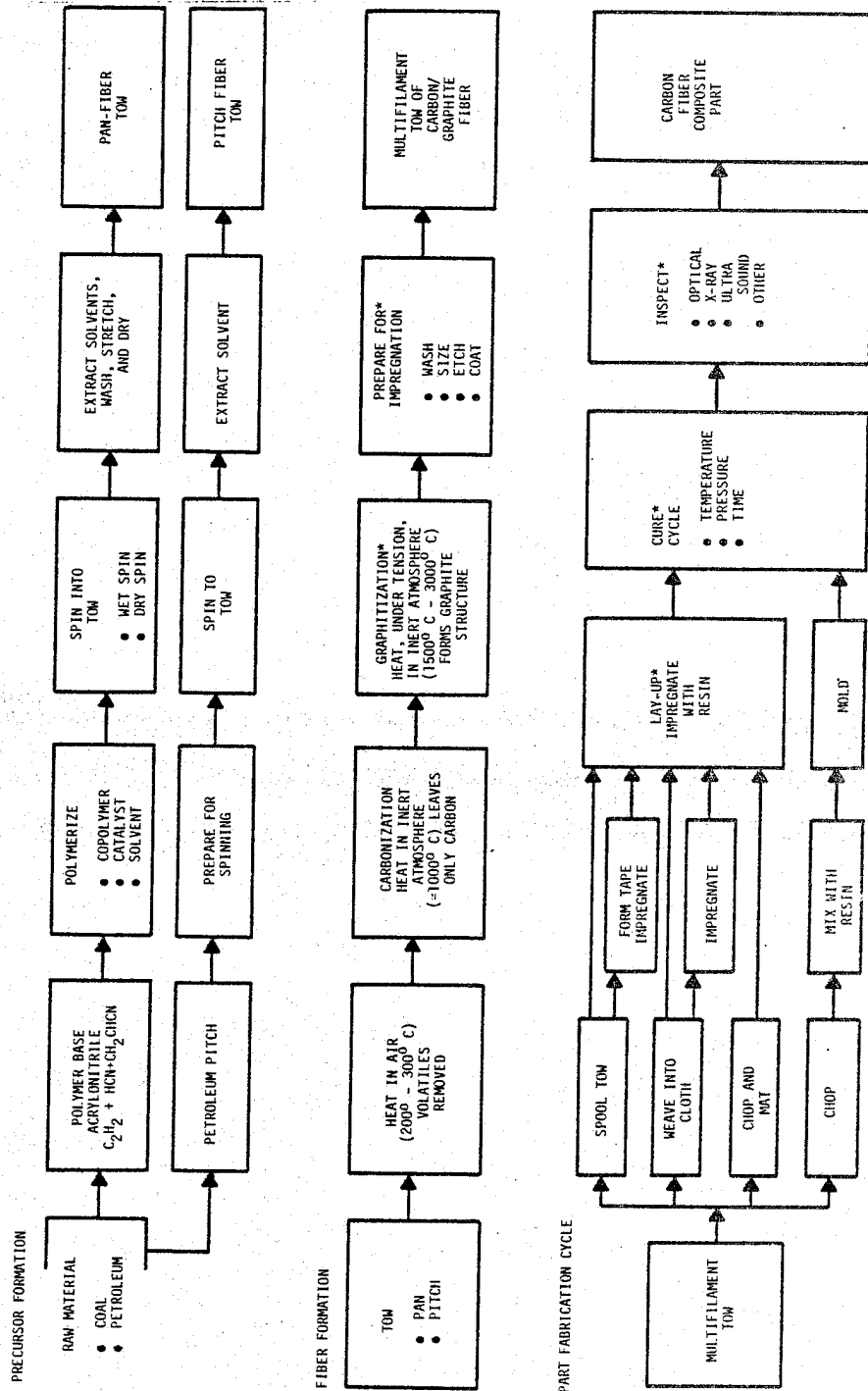

*MAJOR AREAS OF LITERATURE

Figure 2-1. Carbon Fiber and Composite Production Flow Chart.

Precursors

All present carbon fibers are formed from a textile-like fiber called a precursor. Presently, only petroleum pitch and polyacrylonitrile (PAN) are employed for commercial production of fibers for use in structural composites. Pitch-based fibers represent newer developments aimed at lower fiber production cost. The details of the spinning process for pitch-based fibers are proprietary and subject to licensing arrangements between developers and producers.

The bulk of production of carbon fiber for composite utilizes the PAN precursor. PAN variations are popular apparel fibers; Dupont's Orlon is perhaps the best known trade name. The tailoring of a PAN fiber as a precursor for carbon fiber occurs at the polymerization step, and involves the mix of copolymer, catalyst and solvent. The spinning process determines the characteristic cross-section of the final fiber, which may be round, oval or dog bone shaped. The number of spinnerets used and the number of holes in each spinneret determine the number of fibers which make up a tow, the usual functional unit for further processing. The number of fibers in the tow is related to the intended end product. The number of fibers can range from 200 to 100,000; 3,000 fibers per tow is typical.

Fiber Formation

The precursor is converted to a carbon fiber as the result of a three-step heating cycle applied during a continuous drawing process. The precursor is first exposed to a relatively low soak temperature to drive off volatiles and oxidize away any nonpolymerized material. An intermediate heating leaves the carbon atoms, which retain some molecular structure from the precursor. Finally, a combination of high temperature and tension induces the transformation of the carbon to a graphitic structure. Dwell time, temperature and tension combine to produce the mechanical properties desired for the fiber. The details of these cycles are proprietary and the subject of licensing agreements.

The completed fiber can receive a surface treatment as an aid to later fabrication steps. For example, sizing with a dilute epoxy polymer is common for fibers intended for aircraft parts.

Prepregging

The finished carbon fiber tow leaves the formation process on spools, either for shipment or as feed stock for the next step. Depending on the end use, fiber leaves the primary manufacturing process on spools, as woven cloth, as mat, or as chopped material for molding applications. Many applications, particularly those which require the layering of carbon fiber cloth or tape, benefit from impregnation of the tow with uncured resin prior to lay-up. This pre-impregnation of cloth or tape is called prepregging. This operation may take place at the initial fiber manufacturing facility, at the end product production plant, or at an intermediary prepregging operation. The use of purchased prepreg material for production of a finished part implies some limitation in the choice of resin matrix material for binding the carbon fibers together. The most common prepreg materials use epoxy type resins, and are supplied to the aircraft and sporting goods industries.

Part Fabrication

The fabrication of a finished carbon fiber composite part can be accomplished by several methods. The method chosen is related to the application. Some items, such as driveshafts, golf clubs and pressure vessels, lend themselves to filament winding and use spooled tow. Multi-layer fabrications are frequently used for the production of aircraft parts or other relatively thin sections with complex shapes. These lay-up fabrications utilize cloth or tape materials. Various molding processes use chopped fibers in a resin matrix. Certain shapes with uniform cross-sections can be pultruded. Hot stamping, similar to metal stamping, can use cloth or mat.

Once the basic shape has been formed, it is necessary to cure the resin and bind together the composite of carbon fibers and matrix resin. Control of temperature, pressure, atmosphere and time brings about the polymerization of the resin and develops the desired mechanical properties intended for the part. Depending on the resin, the curing conditions can vary from ambient room conditions to 150° C at 4 MPa (600 psi) in an inert atmosphere (aircraft-grade epoxies). Most resins systems commonly in use at present require the application of heat and/or pressure for curing.

Trimming, drilling, sawing, sanding or other machining of the part may be required for finishing. Since most applications take advantage of the strength

characteristics of carbon fiber composites, assurance of integrity is a necessary part of the manufacturing process. A variety of techniques and non-destructive tests is used to inspect the finished product for voids, unwetted fibers, delaminations, incomplete cures and so on.

Fabrication technology includes all the steps involved in lay-up, cure and inspection. All finished goods manufacturing has a potential interaction with the disposal process. Machining, finishing and fitting may result in spoilage. Some parts will not meet quality control standards. Prepregged materials have a limited shelf life, and over-age or partially cured materials are useless for fabrication. All these present a disposal concern.

The definition of an end product (golf club, airplane rudder, etc.) requires the detailed specification of both the particular carbon fiber and the particular resin (e.g., epoxy, polyethelene, etc.) for the binder. Presently, most binders are thermosetting resins; however, for special cases such as injection molding, thermoplastic resins (e.g., nylon) are preferred.

2.2.3 SUMMARY OF RESULTS

The objective of the Literature Search was to identify existing published material pertinent to the problems associated with the introduction of carbon fiber composite materials into American commerce. A primary concern was the fate of carbon fibers subjected to burning; in this area, the survey of the published literature revealed virtually no information of value which was not developed during or incorporated into the Risk Assessments conducted by the various Federal agencies. Although these Risk Assessments are treated as separate portions of the Data Base Report of which this Literature Search is a part, the results of these assessments have been incorporated into the presentation of the findings of the Literature Search, particularly in the section dealing with fire-release of single conductive fibers.

In order to be able to estimate the amount of carbon fiber composite material potentially entering municipal waste streams, it was necessary first to identify areas of present application of these materials. Since this is a developing technology, it was also necessary to evaluate areas of potential future use. Thus, the literature pertaining to present and future applications, including information contained within research publications, was surveyed. This effort largely confirmed earlier expectations that carbon fiber composite materials would be used in aircraft; space and missile hardware; consumer products, particularly premium sporting goods; specialized

industrial equipment, and medical devices. In terms of the total volume of carbon fiber composite materials used, the application of these materials to the transportation industry was identified as a critical factor. The presence of even a relatively small amount of carbon fiber composites in automobiles would, because of the number of vehicles produced, result in a substantial volume.

Applications to specific areas is discussed in some detail in the following section of this document. However, it is important to delineate certain factors which will be important in the development and growth of the carbon fiber industry. The two general considerations governing the future of these materials are technological and economic. Although there is a certain degree of interrelationship between these two factors, a reasonable assessment indicates that technological development of these materials will be largely derived from the aerospace industry; the most profound economic impact on the carbon fiber industry is likely to result from a significant use of composites by the automotive industry.

The aerospace industry has been and will continue to be the technology driver in the area of carbon fiber composites. To a certain extent, the cost of materials is a lesser consideration in this industry than in others. In some applications, composites are the only suitable materials. In others, increased payloads, reduced fuel costs, or other factors justify the use of costly materials. These factors do not preclude the development within the aerospace industry of materials, processes and procedures which, with appropriate adaptations to high production rate needs, will result in the more rapid utilization of carbon fiber composite materials in other sectors of the economy. Even though the products of the aerospace industry show an extremely small potential for entering municipal waste streams, the spin-off of technology could ultimately result in a much greater general use of composites.

The key role which the auto industry will play in the future of the carbon fiber industry is generally recognized in the literature. In the context of the entry of composite materials into municipal waste streams, the automotive industry's use of these materials would represent a significant source. This has been discussed in some detail in Section 5 of this report. A potentially important result of the adoption of these materials by the automotive industry is the economic effect which would result from a substantial increase in the market for fibers. The facilities necessary for the production of carbon fiber composites are expensive; given a relatively small market for these materials, these costs must be spread across a small base, and the unit price is necessarily high. A large increase in the volume produced would lead to a corresponding reduction in the cost per unit.

At present, the automotive industry appears to be the only market for carbon fibers which could cause a substantial reduction in the price of fibers. Such a price reduction would have some straightforward benefits to segments of the economy already involved in carbon fibers. A readily available supply of relatively inexpensive materials with the superior strength and weight characteristics of carbon fibers might result in the incorporation of these materials into products which are now effectively precluded from their use because of cost. A potential exists that carbon fiber composites might be used in a wide range of products which could eventually enter municipal waste streams. In particular, a reduction of the price of fibers would encourage the use of these materials, in the form of chopped fibers, in a wide variety of molded plastic parts. These carbon fiber reinforced plastic parts might then be cost-effectively utilized in a range of relatively inexpensive industrial and consumer products.

The future use of carbon fiber composite materials in transportation equipment will be determined by a number of technical, economic and political considerations. Technological developments leading to reduction of materials costs or increased production efficiencies may result from the efforts of fiber and resin manufacturers, research by the automotive companies, or developments in the aerospace industry. Parallel developments of materials, including non-graphitic fibers such as the aramids, will be important in determining the volume of carbon fibers used in automobiles. These materials might supplant carbon fibers. On the other hand, the use of hybrid materials, incorporating both carbon fibers and other materials to produce the desired characteristics, might result in an expansion of the volume of carbon fibers used.

In addition to inherent economic considerations, the availability of adequate, economical fuel supplies will be an important element in determining the ultimate cost effectiveness of strong, light carbon fiber composites in transportation equipment. Mandated fuel economy requirements and international petroleum supplies and prices will have direct consequences on automotive use of carbon fibers. Recent events indicate that oil prices and supplies are difficult to predict.

Although the Literature Search revealed some interesting and innovative uses of carbon fibers, such as a Japanese investigation of application to electrical power cables, indications are that the key industries in this area are aerospace and transportation. Present assessments of the impact of carbon fiber composite entry into commerce, contained in the Data Base Report and Risk Analyses, indicate little potential hazard arising in terms of entry of these materials into municipal waste streams. Although developments in the aerospace, automotive or carbon fiber industries could alter the complexion of

the carbon fiber industry, a review of the available literature indicates that the fundamental assessments and projections for usage in the Data Base Report are the best available.

The bulk of the published material falls under the category of research. In terms of the needs of the EPA in assessing the impact of carbon fiber composites, two areas of research are of potential importance: applications and properties of materials. The results of the review of research efforts relative to application have been incorporated in the discussion above. Review of research publications related to the properties of materials indicates that virtually all resins now being used or likely to be used in carbon fiber composites would be oxidized at incinerator temperatures. The real concern, then, became the characteristics of the fibers which potentially could be released from the matrix during incineration. All carbon fibers used in structural composites have undergone some degree of graphitization; in fact it is the graphitization which results in the strength characteristics which make carbon fibers an attractive structural material. The structure of the carbon fibers is such that the graphitized portion of the fiber is the exterior. Programs to increase the structural strength of fibers have concentrated on increasing the integrity of the graphitic structures of the fiber, particularly by reducing the amount of non-graphitic impurities. For fibers derived from a polyacrylonitrile precursor material, particular emphasis has been placed on the reduction of the sodium content of the fiber. While efforts of this type improve the mechanical properties of the fibers, they also result in a fiber which oxidizes more slowly and, therefore, is less likely to be consumed during incineration. The precise controls and methods necessary to optimize the structural properties of the fibers result in increased manufacturing costs. In critical applications, the enhanced characteristics may justify the increased expense; in application to products likely to enter municipal waste streams (e.g., sporting goods, automotive, etc.), the use of these superior fibers will probably not be justified because of the concomitant increase in cost of materials. Thus, very high strength, low impurity, highly graphitized fibers are not likely to enter municipal waste streams in large volumes.

In response to a need which arose during the course of the program, a portion of the effort of the Literature Search was directed towards identification of facilities which manufacture or use carbon fibers or composites. A listing of companies involved in carbon fiber manufacture or use was compiled from the literature, including government and private surveys.

Manufacturers working with carbon fibers present a potential source of concentrated volumes of these materials which could conceivably enter municipal waste streams. However,

because of the value of the material and the consequent strict inventory controls generally applied, this eventuality does not appear likely. Accidental releases resulting from malfunctioning of containment equipment, poor procedures, plant fires, and so forth, however, could give rise to a significant release.

Because hazard and fire-release data relative to carbon fibers has the most direct applicability to the needs and concerns of potential users of this report, and because much of this information is contained in a limited number of documents, a relatively detailed bibliography has been presented for this section of the Literature Search.

In terms of applications related publications, much of the material surveyed consisted of articles or presentations which concentrated on a specific, limited application, e.g., the use of graphite/epoxy composites in DC-10 rudders. Since information of this type is likely to be of use to only a limited audience, the bibliography for the application section has concentrated on overview articles covering a range of applications, such as the use of carbon fiber reinforced composites in transportation equipment or sporting goods.

In many areas, research and application overlap; roughly half of all research articles are directly related to a specific application. Because the technology is developing so rapidly, yesterday's research is frequently today's actuality. American and overseas research parallel each other in thrust. However, the survey of research publications revealed little of direct applicability to the concerns of the project, i.e., in the areas of fire-release or application, which had not been included in those discussions and bibliographies. Therefore, the bibliography developed for the research section of the Literature Search has concentrated on recent, accessible publications not aimed at a specific application. Much of this material was published under the aegis of limited number of organizations, particularly the Society for the Advancement of Material and Process Engineering (SAMPE), and appeared in conference proceedings. For the convenience of the investigator, specific publications from these conferences have been grouped together in order of appearance in the Proceedings. The combined American and overseas bibliography represents a distillation of non-applications research publications. The Russian bibliography, on the other hand, is a listing of all Soviet publications related to carbon fibers which were identified during the Literature Search.

Information on the properties of carbon fibers has been largely derived from manufacturer's brochures. Pertinent information on properties of resin systems is frequently a function of the particular product in question; because of the large number of manufacturers and formulations available for a specific resin

type, detailed information should be obtained from the manufacturer or various plastics references.

The lists of producers and users of carbon fibers and composites have been developed from a number of sources: reference to a manufacturer in the literature, brochures, publicly and privately conducted surveys, etc. Manufacturers and users were also contacted by telephone to verify production and/or utilization of carbon fiber composites. Those companies indicating an expectation of application of these materials to their products in the near term were included in the listing.

Each of the areas described above are discussed below as follows:

- 2.3 Hazards, Fire-release
- 2.4 Applications
- 2.5 Research
- 2.6 Fiber, Resin and Composite Properties
- 2.7 Fiber and Composite Producers

2.3 FIRE RELEASES, HAZARDS, PROTECTIVE MEASURES AND INCIDENTS

2.3.1 SUMMARY OF PERTINENT DATA SOURCES AND FINDINGS

Toward the eventual disposal of carbon fiber composite materials, the Risk Assessments performed by the NASA Langley Research Center and performed for the Department of Transportation provide pertinent data for three areas of concern: the release of airborne carbon fiber from fires; the electrical hazards presented by airborne carbon fibers, and the efficiencies of air filters as protective measures. In each case the data pertinent to disposal considerations were contained within the results from a comprehensive test program. A few reports exist which described flame impingement tests for the certification of specific composite parts used in airplanes but these evaluations were not concerned with the release of airborne carbon fibers. The literature identified four health related studies involving exposure to short lengths of unburned fibers; however, at the present time, there have been no adverse health effects defined which are specific to carbon fibers. In addition to data developed relative to air filters, one other study addressed considerations pertinent to the protection of equipment. A limited number of electrical failure incidents have been attributed to airborne carbon fibers. However, the descriptions of these incidents have not appeared in any technical journals or proceedings from symposia.

The findings from this portion of the carbon fiber literature can be summarized as follows:

A. Potential Fire Releases from Incineration

Structural grade carbon fiber composites will release airborne fibers when exposed to the fire zone of a municipal incinerator. The amount of fiber released can be related to the weight of fiber contained in the composite. Up to a one percent equivalent of the initial weight of fiber will evolve as airborne fibers longer than 1 millimeter. These fibers will show an exponential distribution of lengths, with the mean at 1.8 mm. Up to four percent more will appear as fibers shorter than 1 mm; these fibers will have an average length of 0.25 mm. Up to 80 percent of

the fibers may have reduced diameters as a result of oxidation. The average diameter for burned fibers will be 4 micrometers. The oxidizing conditions will result in the release of some fibers less than 4 micrometers in diameter and less than 50 micrometers in lengths. These "respirable" size fibers could appear in quantities up to an 0.05 equivalent weight percent.

B. Electrical Hazards

Fibers longer than 1 millimeter can interact with electrical equipment to cause failures. A comprehensive series of tests defined the failure susceptibility for household, industrial, commercial and avionic items. These results show that the long term effects of carbon fiber emissions from municipal incinerators will appear as a number of failures randomly distributed over the fallout area. The number of failures will depend upon the density of sensitive equipment (e.g., number of items per square kilometer) in the area surrounding the incinerator, as well as the amount of composite incinerated.

C. Other Hazards

As produced, carbon fibers have diameters larger than the air passages leading to the alveoli within the lungs. Studies of animals exposed to chopped fiber produced no conclusive results. Carbon fibers are capable of irritating skin and nasal passages in the same manner as glass or other similar industrial fibrous materials. Therefore, operations conducted in a fiber laden atmosphere have the same requirement for protective clothing and breathing masks. At the present time, the mechanism for human interaction with respirable size fibers has not been defined. As a consequence, all respirable size fibers are a concern. On the other hand, medical applications of carbon, carbon fibers, and carbon fiber composites demonstrates their compatibility with living human tissue. No health hazard has been defined which is specific to any form of carbon fiber.

D. Protective Measures

The testing of materials used in air filter elements showed higher removal rates for fibers than for spherical particles of the same diameter.

Air filter materials designed to remove the dust particles associated with soiling of fabrics or wall surfaces have shown the highest measured efficiencies for removal of airborne carbon fibers. A well designed ventilating system makes an effective barrier to the entry of carbon fibers. Protective measures have been defined for equipment which must operate in a fiber contaminated environment. These measures include the sealing of cases, utilization of high efficiency filters, and selection of equipment options which are inherently not sensitive to airborne carbon fibers.

E. Incidents of Electrical Failure

A total of five industrial failure incidents have been attributed to airborne carbon fibers. The impacts varied from tripped circuit breakers and blown fuses to equipment damage, a destructive fire and power interruptions within a community. The incident at Fostoria, Ohio, remains as the principal example of the effects of an uncontrolled release of airborne carbon fibers. In this incident, fibers, some of them as much as several feet long, were released from an incinerator stack. They were disseminated downwind, and fell on a variety of electrical distribution equipment. Blown fuses, burned conductors, and damage to insulators resulted when these fibers interacted with equipment rated at up to four kilovolts. Higher voltage distribution equipment, however, was not affected. A total of four substations were involved and the last failure occurred more than forty hours after the release. The most distant substation affected by the fibers was six miles from the point of release.

The following paragraphs provide the detail for these findings and are annotated with references identifying the principal source publications.

2.3.2 RELEASE OF AIRBORNE CARBON FIBER FROM FIRES

2.3.2.1 CONTENT OF THE FIRE RELEASE TEST PROGRAM

Both the NASA and the DOT Risk Assessments required data which defined the amount of fiber lofted in the course of accidents involving fires. The recognized conditions which would influence the quantity released included the amount of composite involved, the amount of fuel burned, the location of the composite on the vehicle and the effects of an exploding fuel tank. These variables led to an extensive series of tests

and laboratory investigations; the principal elements became:

1. Laboratory studies and thermogravimetric measurements; combustion and oxidation in still air conducted by the Langley Research Center. (1)
2. Burn and rupture-by-impact tests conducted at the facility in Redwood City, CA, under the direction of the NASA Ames Research Center. (2)
3. Burn in a controlled velocity gas stream. AVCO Corporation, Lowell, MA. (3)
4. Burn, burn-plus-explosion, and burn-plus-impact, U.S. Naval Surface Weapons Center, Dahlgren, Va. (4, 5)
5. Pool Fire Tests conducted at the U.S. Navy China Lake Test Facility. (6)
6. Pool Fire Tests conducted at the U.S. Army Dugway Proving Grounds. (7)
7. Fire Release vulnerability demonstrations conducted in the Shock Tube Facility, Naval Surface Weapons Center, Dahlgren, VA. (8)
8. Burn Simulation of Automotive Accident conditions conducted under the direction of the NASA Ames Research Center at the Redwood City, CA Facility. (9)

All the above tests evaluated structural grade composites. The fiber content of the composites ranged from 60 to 80 percent and all the composites used long strands of high strength graphitized fiber. The testing sponsored by the NASA utilized aircraft grade epoxy resins cured at elevated temperatures and pressures. The composites for simulating automotive accidents utilized polyester and vinylester resins also cured at elevated temperatures and pressures. Such composites are also representative of the compositions utilized in sporting goods and structural parts for industrial applications. No tests evaluated either thermoplastic resins or chopped fibers, both of which are typical of injection molded parts. The testing covered a range of temperatures, a range of times for exposure and a range of oxygen content in the atmosphere. The focus on simulation of accidents led to test conditions which grouped around an exposure of 0.5 hour at 1,000° C in an oxidizing atmosphere. Such conditions also describe the hot zones for typical mass-fired municipal incinerators.

2.3.2.2 FIBERS RELEASED FROM FIRES

The NASA Risk Assessment efforts included a sustained activity for the interpretation and analysis of the fiber materials collected from the fire-release tests (6, 10). These efforts classified the released material into a number of optically distinguishable categories; the principal features of each are listed in Table 2-1.

TABLE 2-1 FIRE-RELEASE FIBER CATEGORIES

<u>CATEGORY</u>	<u>DESCRIPTION</u>	<u>FREE FALL RATE IN AIR</u>
1. Single Fibers	Single fibers up to 8 μ in diameter, and up to 10 mm in length	0.032 m/sec (max)
2. Lint	A group of fibers loosely bound, randomly aligned	0.22 m/sec
3. Brush/Clump	A group of fibers, bound together with well defined alignment	0.88 m/sec
4. Fragments	Pieces of burned composite with dimensions ranging from 2 mm to 25 mm	1.5 to 1.9 m/sec
5. Strips	Elements of composite having lengths comparable to the dimensions of the item being burned	2.0 to 10.0 m/sec

Because of their low free fall rate, single fibers introduced into the gas stream of a municipal incinerator would have the opportunity to remain in the gas stream and be lofted in the plume from the stack. The free fall velocities for the other categories of particulates are compatible with fallout or capture within the flow passages of an incinerator.

An exposure to 1,000 $^{\circ}$ C for 0.5 hour will break down any polymeric resin and permit the release of fibers. In an oxidizing atmosphere, thermogravimetric measurements show epoxies oxidizing rapidly at temperatures above 300 $^{\circ}$ C and structural grade carbon fiber oxidizing rapidly at temperatures above 650 $^{\circ}$ C (1). In an actual fire situation, the combination

of these effects can result in the complete oxidation of some of the material, the production of residue, and the release of some fibers. A conservative summary for these results from all the NASA-sponsored fire-release testing appears in Figure 2-2 (10). The percentages refer to the equivalent weight percent of the fiber originally present in the composite. The actual weight present in the released single fibers will be lower than the weight of the input fiber because of partial oxidations. However, the combination of numbers and lengths will add up to a quantity which represents one (or more) percent of the original fiber. The release of single fibers begins as soon as the epoxy starts to oxidize. Measurements of fibers in smoke plumes have detected carbon fibers within the first minute of combustion (7). However, in any fire situation the release rate is influenced by the degree and type of agitation. Table 2-2 summarizes the data from evaluations of agitation in combination with data from the exposure of composites to fires. The conditions within municipal incinerators are a combination of mechanical agitation (movement of grates) and relatively low velocity air. A conservative estimate places the potential emissions from the fire zone of an incinerator at one percent for fibers longer than 1 millimeter. These measurements, plus the summary weight balance data shown, lead to the following assessments for the amounts of fiber which could be released from the fire zones of municipal incinerators.

- A. Up to one percent of the input fiber could appear as single fibers in the length range 1 mm and longer. These fibers would show an exponential distribution in lengths with the mean at 1.8 mm. Oxidation would reduce the diameters of up to 80 percent of these fibers. For fibers with an as-produced diameter of 8 micrometers, the average diameter of the fire-released fiber would be 4 micrometers.
- B. Up to four percent of the input fiber would appear as single fibers less than 1 mm long. The average length would be 0.25 mm. Oxidation would reduce the diameters for up to 80 percent of the population; the average diameter would be 4 micrometers. As much as 0.05 percent of the input fiber could appear as fibers shorter than 50 micrometers and with diameters reduced below 4 micrometers.

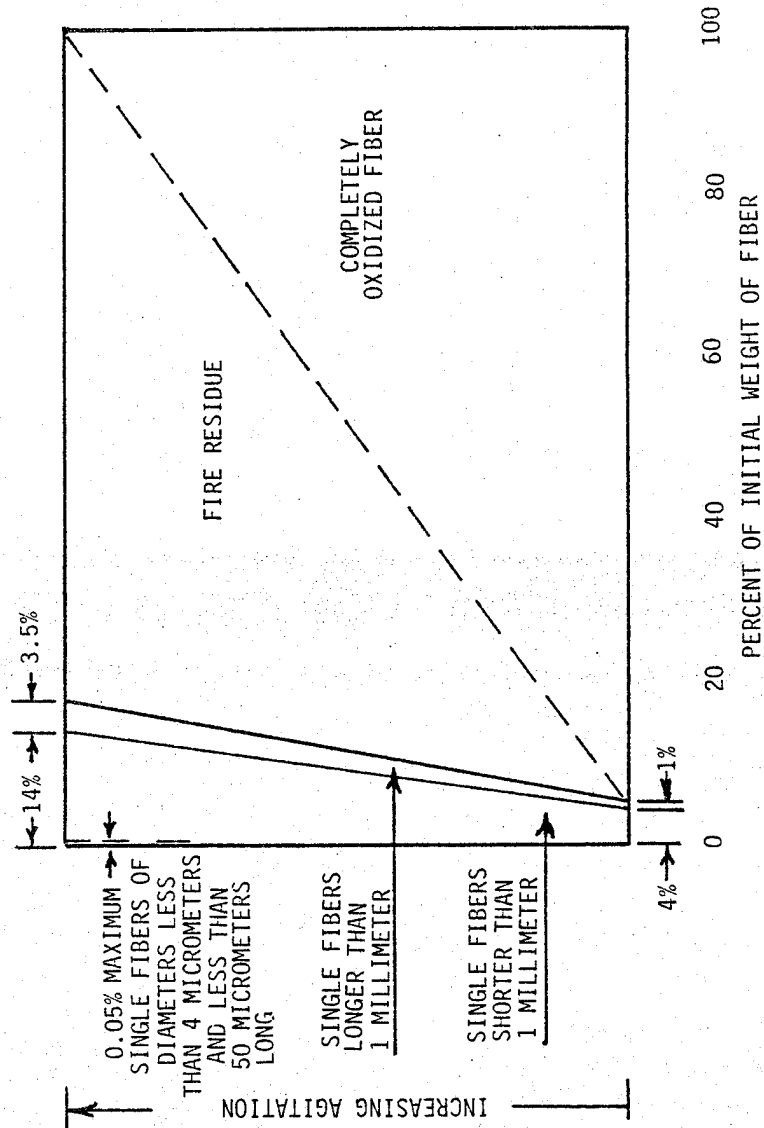

FIGURE 2-2. Mass Balance for Carbon Fibers from Burned Composites.

TABLE 2-2 SUMMARY OF CARBON FIBER RELEASE DATA
FOR ELECTRICAL HAZARD LENGTHS

<u>NASA RISK MEASUREMENTS, SUMMARY</u>	<u>RELEASE FRACTION</u>
● Burn Only Quiet Air	0.01 Percent
● Mechanical Agitation	0.1 Percent
● Low Velocity Air (15 meters/sec)	1.0 Percent
● High Velocity Air	8 Percent
● Explosives	10 Percent
 <u>DOT Risk Measurements</u>	
● Burn in Air Stream	0.06 Percent

2.3.3 ELECTRICAL HAZARDS FROM AIRBORNE CARBON FIBERS

2.3.3.1 TESTING FOR ELECTRICAL HAZARD EFFECTS

Carbon fibers are electrically conductive; a one centimeter length of structural grade fiber will show an electrical resistance of a few thousand ohms. Fibers longer than 1 millimeter have the potential for bridging the distances between conductors and interfering with the operation of a circuit. In low power circuits the fiber presents a sustained resistive short. In power circuits above 30 volts, fibers can precipitate sustainable arcs. A concern also existed for circuits in ungrounded cases where a fiber could present a conductive path and result in a shock hazard. These effects received in-depth evaluations supported by comprehensive test programs. The principal elements included:

- (1) An evaluation of household appliances and equipment (11, 12, 13).
- (2) An evaluation of avionics equipment (14, 15).
- (3) Evaluations of shock hazards (16).
- (4) Evaluation of industrial impacts (17).
- (5) Evaluation of arcing effects (18).

(6) Evaluation of electrical power distribution equipment (19, 20).

The execution of the evaluations included measuring the effects over a range of fiber lengths and electrical resistances of fibers, and covered representative designs in the packaging of a circuit. The evaluations included analyses, measurements from probes, and exposures in chambers. The principal data were obtained from in-chamber test exposures using cut-to-length unburned fiber. These data were later confirmed by tests in a fire release environment (7). The results of these tests provided the experimental data which supported predictions of failures for both the NASA and DOT Risk Assessments.

2.3.3.2 DEFINITION OF THE ELECTRICAL HAZARD, RESULTS OF TESTING

The potential for airborne carbon fibers to cause electrical failures is described in terms of an exposure, E, defined as the residence time, t, in seconds within a concentrated population, C, expressed as fibers per cubic meter. Thus:

$$E \frac{\text{fiber seconds}}{(\text{meter})^3} = \int C dt$$

For any item of electrical equipment, a series of tests to the onset of failure will define an average value for an exposure to cause a failure (\bar{E}). The values of \bar{E} have been shown as characteristics of the item and related to the configuration. The probability for failure (P_F) of an item of equipment from a local exposure (E) to carbon fibers takes the linear exponential form:

$$P_F = 1 - e^{-E/\bar{E}}$$

In the fire release incidents studied, most of the fallout did not impose a local exposure which approached the values for \bar{E} . Consequently, the approximation based upon a series expansion led to the practical form:

$$P_F = \frac{E}{\bar{E}} \quad \text{where } E \ll \bar{E}$$

The test-determined values for \bar{E} ranged upward from 10^5 fiber seconds per meter³. The practical upper limit for chamber test exposures became $E = 10^8$ (3 hours at a concentration of 10^4 fibers/meter³). Equipment showing no failures after a series of exposures to $E = 10^8$ were considered insensitive to carbon fibers. ($\bar{E} \gg 10^8$ fiber seconds/meter³). Thus, the present data conforms to a mathematical definition for the carbon fiber hazard to electrical equipment as the probability for a single

fiber to cause a failure. These single fiber probabilities have been shown to exceed the probability for failure by multiple fibers by more than an order of magnitude (21, 22).

A. Hazards to Electronics and Consumer Items

The in-chamber exposures of electronics and consumer oriented equipment involved more than 40 types of items and covered a representative cross-section of domestic usage (21). The compilation of data for E showed an apparent lower limit which corresponds to uncoated circuitry in unfiltered, fan-cooled cabinets (typical of some home use audio amplifiers). Figure 2-3 summarizes the results of testing for those items which failed in test. A large fraction of the equipment tested did not fail. Within the 24 types of consumer household items tested only color televisions and microwave ovens sustained a failure which interrupted the function, 12 types of equipment showed sensitivity to a non-interruptive type of failure, and the balance were unaffected.

B. Arcing and Hazards to Power Distribution Equipment

A fiber falling across the open contacts of high power, high voltage equipment can start an arc. Although the fiber is vaporized, the arc persists in accordance with the well-established dynamics for arcs. In effect, the arc precipitating characteristics of airborne carbon fibers are no different than those of other conductive contaminants. For direct current, the voltage gradients for arc breakdown are well defined in contemporary literature. A carbon fiber entering such a field will align with the field and move toward an electrode. If the length of the fiber reduces the gap distance sufficiently, local threshold voltage for breakdown is exceeded, and an arc occurs and continues until interrupted by current breakers or other means. Since most power circuits carry some form of protection, the damage potential relates to the reaction time of the interrupter. Again, the damage potential is no different than for any other contaminant. In single phase 60 cycle alternating current, arcs occur to ground; the voltage reversal limits burning time to less than a half cycle; circuit breakers rarely trip. In three phase alternating circuits, arcs between phases can sustain until interrupted by circuit breakers. At 110 and 220 volts practical considerations keep the leads sufficiently distant to avoid problems.

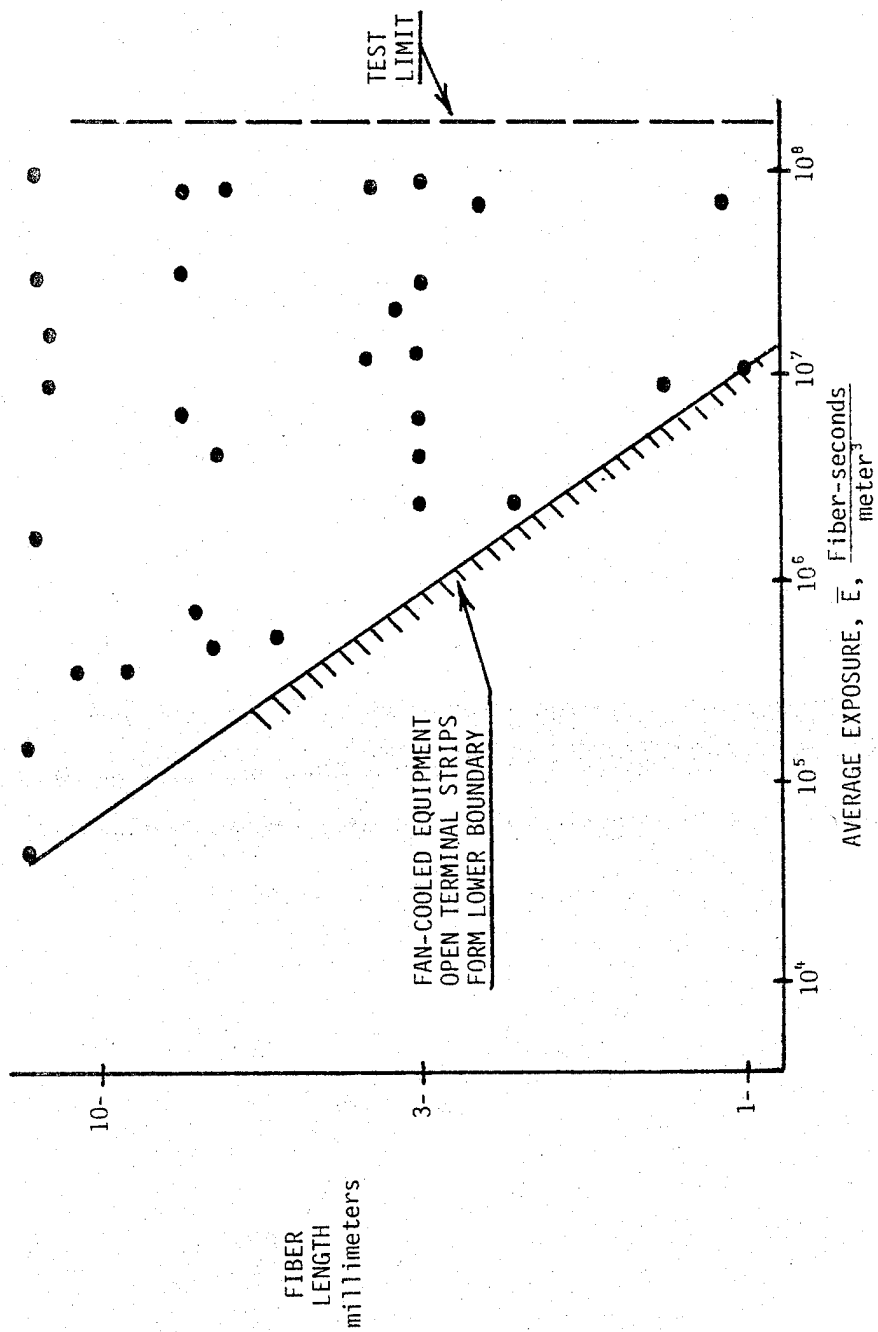

FIGURE 2-3. Average Exposure to Failure for Vulnerable Equipment.

At 440 volts, open terminals do show values for \bar{E} very similar to those measured for fan cooled electronic equipment (See Figure 2-3). Industrial wiring codes protect power circuitry by combinations of lead spacings and specification on enclosures (NEMA Standards). The minimum enclosures offer substantial protection; many enclosures are totally sealed. At the higher voltages the spacings required are orders of magnitude beyond the lengths of the fibers which have been released from burning composites.

Power distribution systems rely on distance between conductors and circuit isolators as protection against conductive debris. The design of a transmission line balances the degree of protection against the consequence of a failure. In such an environment contamination of insulators becomes the area of concern. At distribution voltages (4kV and up) testing of insulators has shown that a single fiber of fire-release origin cannot precipitate a flashover type failure (19). Analysis of distribution systems show the impact of carbon fibers insignificant against the level of outages caused by other natural causes (20).

C. Hazards from Electrical Shocks

The review of electrical equipment capable of presenting a potential for an electric shock showed only 6 items in which the casing could be raised in voltage by the action of a carbon fiber. Of the household items, toasters presented the potential for a hazard. Testing of toasters for shock hazards showed values of \bar{E} which effectively eliminated these items from consideration (16, 21) such that the probability of failure for an individual item will be small. The result will be random failures with the number of failures in proportion to the number of sensitive units in the area which received the fallout.

To summarize, for the case of carbon fibers released from municipal incinerators, the literature shows the airborne fibers will have a potential opportunity to interact with a limited number of equipment types. The dispersion of fibers downwind will dilute the concentration to the point where any failures will appear as random, and not readily distinguishable from the failures caused by other effects.

2.3.4 OTHER HAZARDS

Industry recognized that manufacturing processes could produce airborne carbon fibers in the workplace and instituted some studies. The initial studies into potential toxic effects were performed on laboratory animals by researchers in Britain. At the University of Newcastle on the Tyne (23) researchers involved in carbon fiber application to dentistry used rats and mice as implantation subjects, with silk thread used as control. Eight hundred animals were used, and post mortem examinations were performed on the surviving animals after 18-24 months. Of those fibers found in the tissue of the subjects, many were encapsulated with connective tissue, and only one fiber was associated with a malignant tumor. Researchers at the University of Reading (24) exposed guinea pigs to carbon fiber dust. Equipment problems limited the concentration achievable during the 100 hour exposure. Post mortem examinations over a period of 27 weeks found the particles had been coated as in the dental study. Only one particle had reached the alveoli of a lung, but no pathological effects were observed.

The industrial concern centered on the safety of workers involved in the various operational steps that go into the manufacture of carbon fiber composites. At the Fort Worth Division of General Dynamics an in-house industrial hygiene survey was performed around cutting and grinding operations on a wing panel composed of graphite composite materials (25). Airborne particulates were collected during the trimming operations, examined under dark phase microscope (as one would asbestos fibers), enumerated, sized and categorized as graphite fibers or not. Analysis of materials trapped by personnel air filters indicated that less than 8 percent particulates were fibrous; of those, approximately 5 to 6 percent were identified as graphite fibers. The graphite fiber lengths ranged from 7 μ m (their diameter) to 70 μ m and it was estimated that at least 80 percent of all graphite fibers found were well above the respirable range. The study concluded by stating that no evident health problem was involved in the cutting and grinding operations but respirators should be worn for the usual hygiene reasons.

Another study conducted in a composite processing environment at the Vikram-Sarabhai Space Center, Trivandrum, India, (26) also resulted in such low levels of dust from composites that no appreciable difference in concentrations was observed between conditions with and without exhaust systems operating.

The burning of carbon fibers will result in a quantity of respirable sized particles, many with irregular shapes (24). The data available from health hazard studies did not show any evidence of an effect specific to carbon fibers. Therefore, airborne carbon fiber should be considered in the context of any

other fibrous aerosol of similar dimensions and be afforded the same considerations relative to protection of individuals working with the materials.

2.3.5 PROTECTIVE MEASURES

2.3.5.1 PROTECTION AFFORDED BY AIR FILTRATION

The Risk Assessments required data which defined the interactions of airborne fibers with the features of ventilation systems. A comprehensive series of tests on air filter media supplied the needed data (28). Most of the widely used materials received an evaluation and they included window screens, polyurethane foam, fiberglass and high density mat. The results from this series of tests show that filter media will capture fibers more efficiently than they will a spherical particle of the same diameter. The risk assessments needed data which would allow the computation of the local exposure for an item of electrical equipment located indoors. The effects of buildings and the components of ventilating systems took the form of a "transfer function" which represented that portion of the fiber population which passed through the barrier (window screen, air conditioner, filter, etc.). As part of the supporting analysis transfer function measurements from testing were compared with filter efficiencies as rated by the standard techniques defined by the ASHRAE (American Society For Heating, Refrigeration and Air Conditioning Engineers). Figure 2-4 shows such a comparison and indicates a usable correlation (18). The example shown compares fiber removal with the rating applied to filters intended for control of the dust particles associated with soiling of clothes and walls. A ventilating system configured for the control of such contaminants offers an effective barrier to the passage of airborne carbon fibers.

2.3.5.2 PROTECTIVE MEASURES FOR CARBON FIBER MANUFACTURING FACILITIES

An in-depth review of the electrical hazards associated with carbon fiber, together with manufacturing methods for avoiding these hazards was published by J. J. McFerrin and O. C. Trulson of Union Carbide Corporation, Carbon Products Division, in March, 1979. Their real-life manufacturing experiences in Union Carbide's facilities offer reference information with regard to carbon fiber release in the manufacturing setting; some indications of the problems which might be encountered with disposal of such materials; and considerations of possible solutions.

The prevention of fiber induced damage to electrical equipment from the manufacturing standpoint lies in control of fiber release in the plant proper. It is accepted that during

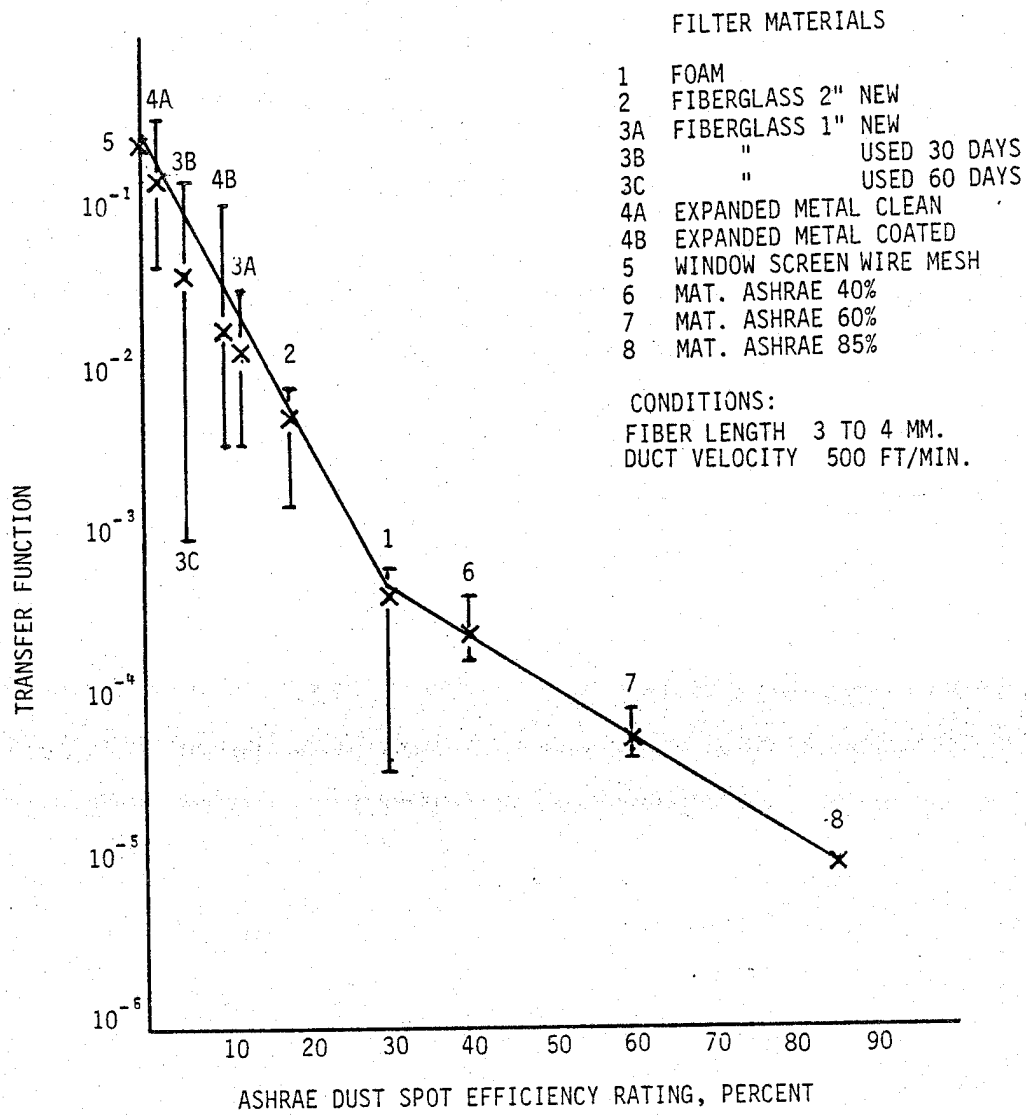

FIGURE 2-4. Transfer Functions for Air Filters Compared to ASHRAE Dust Spot Efficiency Ratings.

manufacture of carbon filaments, low-level concentrations of airborne fiber particles occur at some points of the production process, and higher concentrations will result if dust collection systems fail.

In the early stages, the authors noted that normal protections against carbon dust proved inadequate and virtually all types of equipment and circuits shorted out; however, with a better understanding of the conductivity and air-dispersion characteristics of carbon fibers, methods were developed to avoid such failures.

The authors stressed that the single most effective system to avoid electrical problems was preventive maintenance. The principle methods involved were:

1. Adequate dust collection systems with hoods at likely fiber release points.
2. Stronger maintenance procedures for dust-tight enclosures; including pressurizing larger cabinets and imposing rigid clean-up procedures before and after opening equipment.
3. Insulating exposed contact terminals with insulating paints, or hardsetting cements.

In the design considerations for a new facility, plans should include, if feasible:

1. Utilizing separate enclosures rather than large cabinets containing numerous circuits.
2. Locating control circuits, panels and other sensitive equipment outside the production room, though emergency and secondary equipment should be inside.
3. Assuring that the various insulating techniques mentioned under preventive maintenance are employed.
4. Using alternating current instead of direct current motors, where applicable, to avoid brush and commutator exposure.

The authors also noted that process waste and end-of-life disposal will become problems as production of carbon fibers and their composites increase during the next few years. They suggest investigating the technology and economic feasibility of recycling wastes into forms of filler materials where their electrical and chemical properties can be used to advantage. If re-use is not feasible, then landfill was the next step.

2.3.6 REPORTED FAILURES

The literature suggests that there have been frequent electrical problems in carbon fiber or composite-producing facilities. Many of these have apparently been minor in nature, and frequently were encountered during start-up operations. Generally, the preventive maintenance and design considerations discussed above have been sufficient to solve these minor problems. On a larger scale, there are five specific incidents which have been related to carbon fibers. The incidents are summarized in Table 2-3. In two of the incidents (Polycarbon Corporation and NASA-Langley Research Center) there is a consensus that carbon fibers precipitated the incident. The Morganite Modmor and Great Lakes Carbon incidents are considered to have been a result of the interaction of carbon fibers with electrical equipment. In both cases, untreated carbon fiber was present, and improved housekeeping procedures and preventive maintenance were effective in solving the problem.

The most important incident in terms of size, impact, and application to incineration occurred at the Union Carbide Plant in Fostoria, Ohio in May of 1972 (30). Several cubic feet of untwisted carbon fiber filament was inadvertently placed in an incinerator. Fibers of varying lengths, some as long as three feet, were emitted from the high stack of the incinerator and borne downwind on 3 to 7 mile per hour winds. Numerous electrical problems ensued. Both within the facility and as far as six miles away, equipment up to four kilovolts was shorted out. Three substations suffered outages. Even though the accidental incineration was quickly recognized and much of the fiber was retrieved from the incinerator, outages continued to occur for forty-eight hours, indicating that there may have been some resuspension of the fibers after initial settling. Equipment operating at 15 to 68 kilovolts was exposed, but no failures were experienced.

TABLE 2-3. SUMMARY OF INCIDENTS

LOCATION AND DATE	RELEASE CONDITIONS	EFFECTS	COMMENTS
A. Union Carbide Corp. Fostoria, Ohio May 1972	Inadvertent incineration of virgin filaments; release from high stack carried on 3-7 mph winds.	Union Carbide plant affected with numerous and repeated outages. Three substations, supplying source-plant and two plants nearby outaged. Pole mounted transformers, other equipment shorted in city as far as six miles downwind. Effects experienced for 48 hours.	Short single fibers and clumps of fibers responsible for damage. Equipment up to and including 4kV rating shorted. One phase to phase fault occurred, though spacing was 31 inches. Though exposed, 15-60 kV insulation experienced no failures. Although second 24-hour period was damp and misty, indications are that some redistribution of fibers had occurred.
B. Morganite Modmor United Kingdom April 1972	General release during normal processing operations of carbon fiber manufacture.	Numerous power supply and electrical processing equipment shorted, including radio-frequency pyrolysis equipment.	Effects restricted to plant and immediate environs. Discussion with plant officials confirmed similar incidents had occurred at other pilot production plants.
C. Great Lakes Carbon Corp. Elizabethton, Tenn June 1970-Jan 1973	Prototype fiber production facilities. Electrical problems occurred at research facility shortly after start-up. General processing and improper disposal of waste materials primary causes.	Numerous small electrical failures in plant, several major pieces of equipment affected. Damage to windings, bus-bars, fuses tripped on equipment up to and including 4.8 kV ratings.	Waste fiber materials were being disposed of in a dump located immediately behind plant. Improved housekeeping measures, enclosure or electrical equipment, and well-maintained ventilation equipment led to uninterrupted processing.
D. Polycarbon Corp. N. Hollywood, CA October 1973	Undetermined. Small company; relative newcomer to industry.	Suffered large-scale destructive fire attributed to an electrical fault.	Examination of site revealed surrounding area severely contaminated by fibers. Impossible to determine if contamination caused fire, or vice versa.
E. NASA-Langley Research Center, Hampton, Virginia April 1979	Incident occurred in room where fabrication of graphite fiber sheets was performed. Fabrication, cutting, grinding machines all ventilated with fume hoods. Machines not in operation at time of incident.	Electrical failure at 3-phase, 480 V panel. All three phases affected. No indication fault at panel went to ground. Resultant overload tripped 324 amp substation relay located outside of building.	Damage minimal; repairs effected quickly; no downtime experienced. Inspection revealed several fibers in panel enclosure. Severe fiber contamination on inside of exhaust systems. No concrete evidence that fibers caused failure. Whatever the cause, probably destroyed in process.

FIRE RELEASE AND HAZARD

BIBLIOGRAPHY

1. Bell, V. Source of Released Carbon Fibers. NASA Conference Publication 2074, 1979. pp. 41-70.
2. Wilton, C., Kamburnoff, G., and Boyes, J. Fire Testing of NASA Samples - Phase I. (Scientific Services, Inc., NASA Contract NAS2-9945) NASA CR-152339, 1979.
3. Alexander, J. G. Development of Fire Test Facility for Graphite Fiber Reinforced Composites. (AVCO Specialty Materials Division, NASA Contract NAS1-15511). NASA CR-159193, 1980.
4. Babinski, T. C., and Musselman, K. A. Burn/Blast Tests of Aircraft Structural Elements. U.S. Naval Surface Weapons Center, NSWC/DL TR 3897, 1978.
5. Babinski, T. C. Fiber Release from Impacted Graphite Reinforced Epoxy Composites. NSWC/DL TR 80-216, 1980.
6. Lieberman, Paul, Chovit, Alan R., Sussholz, Benjamin, and Korman, H. F. Data Reduction and Analysis of Graphite Fiber Release Experiments. NASA CR-159032, 1979.
7. Pride, Richard A. Large Scale Carbon Fiber Tests. NASA TM-80218, 1980.
8. Pride, R. A., McHatton, A. D., and Musselman, K. R. Electronic Equipment Vulnerability to Fire-Released Fiber Exposures. NASA TM-80219, 1980.
9. Hathaway, W. T. and Hergenrother, K. M. Risk Assessment of Carbon Fiber Composite in Surface Transportation. NASA Conference Publication 2119, 1980. pp. 275-279.
10. Bell, V. Release of Carbon Fibers from Burning Composites. NASA Conference Publication 2119, 1980. pp. 29-57.
11. Lovett, C. D. and Wise, R. A. A Study of the Effects of Carbon Fibers on Home Appliances. National Bureau of Standards Report NBS-IR-79-1952, 1979.

12. Stumfel, Charles R. and Weaver, Calvin E. Measured Carbon Fiber Exposures to Malfunction for Civilian Electronic Items. ARBRL-MR-02943. U.S. Army Ballistics Research Laboratory, 1980.
13. Morrissey, John A., Wolfe, Neil M., Patrick, James H. and Brannan, William L. Measurement of Carbon Fiber Exposure to Failure and Possible Shock Hazard for Household Equipment. ARBRL-MR-02945. U.S. Army Ballistics Research Laboratory, 1980.
14. Meyers, Jerome A. and Salmirs, Seymour. The Vulnerability of Commercial Aircraft Avionics to Carbon Fibers. NASA CR-159213, 1980.
15. Morrissey, John A., Taylor, Clifford, Brannon, William I. and Patrick, James H. Measurement of Carbon Fiber Exposures to Failure for Certain Aviation Components. ARBRL-MR-02944. U.S. Army Ballistics Research Laboratory, 1980.
16. Meyers, Jerome A. The Potential of Carbon Fiber Induced Shock Hazards in Household Toasters. NASA CR-159147, 1979.
17. Butterfield, A. J. Surveys for Sensitivity to Fibers and Potential Impacts from Fiber-Induced Failures. NASA Conference Publication 2074, 1979. pp. 141-158.
18. The Bionetics Corporation. Experimental and Analytical Studies for the NASA Graphite Fiber Risk Assessment. NASA Contract NAS1-15238. NASA CR-159214, 1980.
19. Garrity, T. and Eichler, C. Effects of Carbon/Graphite Fiber Contamination on High Voltage Electrical Insulation. NASA Conference Publication 2119, 1980. pp. 235-265.
20. LaRocque, G. R. An Assessment of Power System Vulnerability to Release of Carbon Fibers During Commercial Aviation Accidents. NASA CR-159208, 1980.
21. Taback, I. Evaluation of Equipment Vulnerability and Potential Shock Hazards. NASA Conference Publication 2119, 1980. pp. 73-99.
22. Elber, Wolf. A Statistical Analysis of Electrical Equipment Vulnerability to Carbon Fibers. NASA TM-80217, 1980.

23. Bowman, A. J., Cook, M, Jennings, E. H. and Rannie, I.
Final Report on Long-Term Toxicity Studies on Carbon
Fibre Implants. The Dental Hospital, Newcastle Upon
Tyne. The Dental School, University of Newcastle Upon
Tyne.
24. Holt, P. F. and Horne, M. Dust from Carbon Fiber.
Department of Chemistry, University of Reading,
England. Environmental Research 17, 1978. pp. 276-283.
25. Eastes, J. E., Environmental Specialist. Airborne Fibers
Near Cutting and Grinding OPS on Graphite Composites.
Copy, Industrial Hygiene Survey, General Dynamics
Corporation, Fort Worth Division, Sept. 14, 1979.
26. Enamethu, M. Dust and Fume Control In a Composite Processing
Laboratory. Vikram Sarabhai Space Center, Trivandrum,
India. 10th National SAMPE Technical Conference, Vol.
10, Oct. 1978.
27. Sussholz, Benjamin. Evaluation of Micron Size Carbon Fibers
Released from Burning Composites. TRW Defense and
Space Systems Group, NASA Contract NAS1-15465. NASA
CR-159217, 1980.
28. Paszek, John J, Davis, Dudley D. and Patrick, James H.
Carbon Fiber Transfer Functions Through Filters and
Enclosures. ARBRL-MR-02946. U.S. Army Ballistics
Research Laboratory, 1980.
29. McFerrin, J. H. and Trulson, O. Conran. Electrical
Equipment Protection and Waste Disposal Practice -
Carbon Fiber Manufacture. SAE Technical Paper No.
790034, Society of Automotive Engineers Congress and
Exposition, Detroit, Feb. 26 - Mar. 2, 1979.
30. Carbon Fiber Study, NASA TM-78718, 1978.

2.4 APPLICATIONS

Carbon or graphite fiber composites have been and are being utilized in applications where the high strength, light weight, dimensional and chemical stability, and/or other physical properties of carbon-based fibers lead to immediate or long-term economies (fuel economy, payload increase, etc.) or satisfy specific design requirements (thermal shock characteristics, radiation resistance, corrosion resistance, biocompatibility, etc.). The descriptions of applications in this section have been grouped according to industry and ordered according to potential for entry of the products into municipal waste streams. The major industries using or projected to use significant quantities of carbon fiber composites are Consumer Products (particularly sporting goods); Surface Transportation; Industrial Equipment; Medical Devices; Aircraft; and Space.

Consumer Products

Carbon fiber composites have well established applications to consumer oriented items, particularly as premium quality sporting goods such as tennis and racquetball rackets and fishing rods. Because individual items generally consume only small amounts of material and can be manufactured by well established fabrication techniques, an item of superior performance can be produced at a price within reach of most dedicated sports enthusiasts. The sporting related applications extend into skis, ski poles, canoes, masts for sailboats and corrosion resistant marine fittings. Experimental applications include hulls for competition sailboats, hang glider components, and body shells for racing automobiles. Applications to competition-oriented equipment often use more than one type of fiber (carbon and glass or Kevlar, e.g.) in the lay-up sequence. Other established areas of consumer use include radio antennas, musical instruments, and tone arms for phonographs. In each application, properties such as light weight, stiffness, corrosion resistance and/or vibration damping provide a product with superior performance characteristics.

The large number of carbon fiber composite sporting goods items and brand names on the market does not necessarily represent an equally large number of manufacturers in the United States. An entire item (e.g.,

tennis racquet) or portion of an item (e.g, golf club shaft) may be produced by a domestic or off-shore manufacturer under subcontract to the firm marketing the finished product. Since many of these products utilize a relatively small amount of carbon fiber, labor costs associated with fabrication represent a large proportion of the total manufacturing cost; thus, it is not uncommon for the fabrication to be done in low labor cost regions such as Taiwan or Korea. For the same reason, a reduction in the cost of fibers would have a minor effect on the price of the finished product. Developments in fabrication technology, including spin-offs from other industries, will serve to reduce costs and lead to an increased utilization of carbon fiber composites in consumer-oriented equipment. Most premium quality consumer items tend to have long lives and result in slow entries into waste streams. Nevertheless, consumer items may be considered as the prime source for carbon fiber-based materials entering into a municipal waste stream. In time, the production and scrap-out will come into a general equilibrium. The distribution of such scrap would follow that for the general population; some degree of regionality may be introduced for skis, boats or fishing rods.

Surface Transportation

The application of carbon fiber composites to surface transportation equipment focuses upon the automobile. The Ford Motor Company has shown a continuing interest and has led the development of technology for applications of carbon fiber composites to surface transportation equipment.

The experimental program considered nearly every automotive part presently made from metal as a candidate for replacement by a carbon fiber-based composite. The Ford development program extensively evaluated sheet metal structures, drive trains, running gear and springs with varying degrees of success. The carbon fiber Ford LTD displayed in February, 1979 stands as the showpiece for carbon fiber application to automobiles (Figure 2-5). This experimental model achieved a weight reduction of 1,250 lbs. from the nominal 3,750 lbs. weight of a standard vehicle. The composites offered nearly a one-pound-replaces-three weight advantage relative to steel. Ford has made a limited production run of air conditioner mounting brackets for the 1980 Mustangs. Less than 5,000 brackets were fabricated (~0.2 lbs of carbon fiber per unit) and less than 1,000 were installed. The entire Ford

Weight = 2517 Curb, 2750 Inertia
 Fuel Economy Objective = 23.0 MPG Metro Highway
 Performance Objective 0-60 = 12.0 Seconds

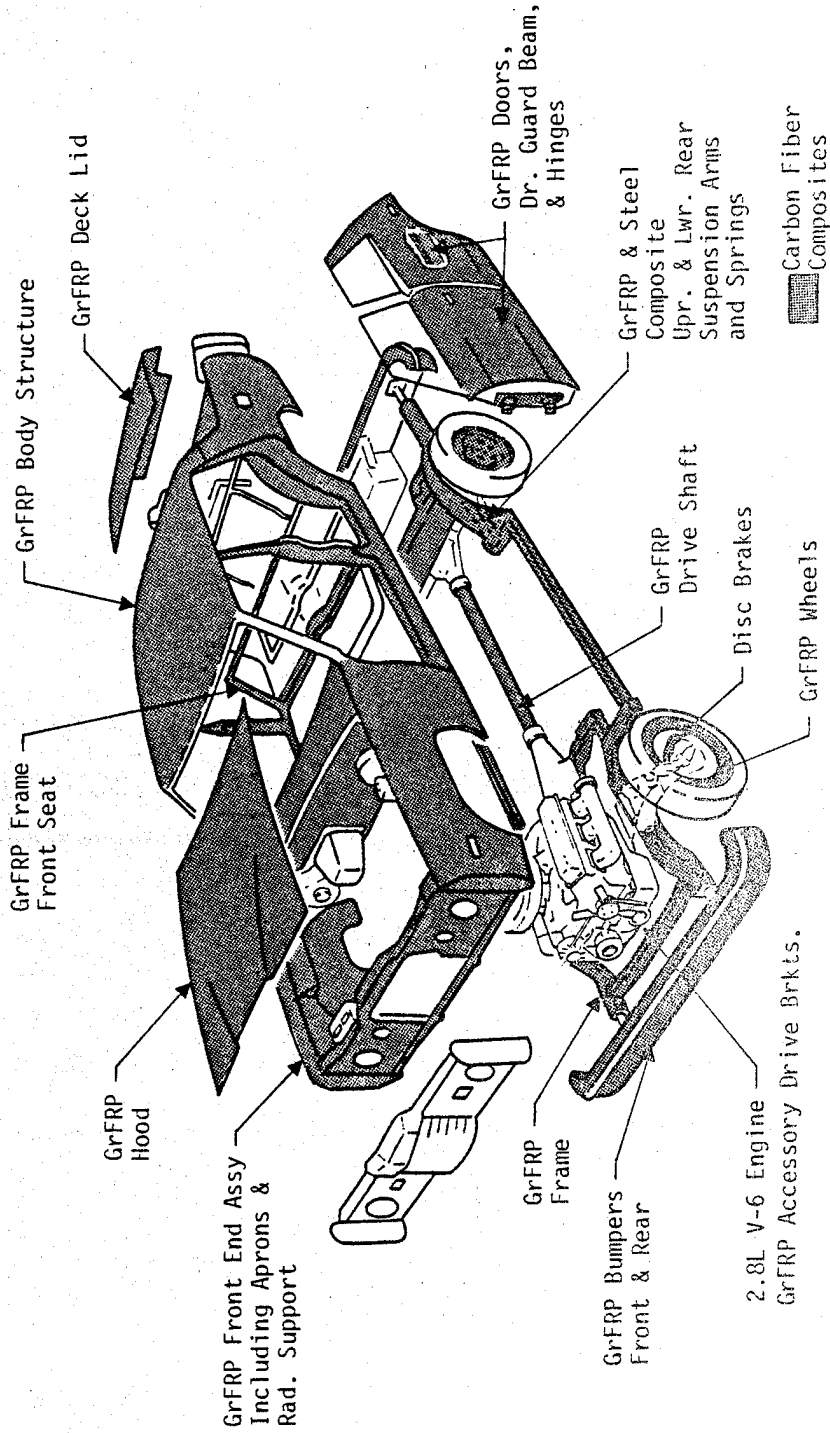

Figure 2-5. Candidate Automotive Application For Carbon Fiber Based Composites.
 (Ref. Ford LID Display Unit)

program has served to generate experience with design, manufacture, test and handling of carbon fiber-based composites. The items which have appeared as possible near term developments include springs, torsion bars, door guard beams and door hinges. Other evaluations have shown a promising application to trucks as frame stiffeners and in drive shafts. A limited application has appeared as push rods and rocker arms in the valve linkage of high performance engines. Efforts to develop connecting rods have had limited success, other engine components have only reached the prototype stage in development.

While the potential for weight reductions to meet the 1985 fuel economy requirement make carbon fiber composites attractive, the actual application of such composites to automobiles faces three major obstacles. The present cost of carbon fiber makes it prohibitive for general automotive applications and doubts exist whether the economics of high production can ever reduce the price of carbon fibers to a range competitive with other materials. The technology for high speed production of carbon fiber composites has not been developed to the degree necessary for general automotive use. Techniques which produce 400 aircraft items per year are not readily adapted to the 400-per-hour rates associated with automotive components. Finally, automotive production does not appear compatible with the slow, high-temperature, high-pressure cure cycles inherent in the polymerization of an epoxy type chemical bond. Therefore, automotive applications may require additional developments to provide a suitable resin system.

The application of carbon fiber composites to automobiles has been the subject for studies within the DOT and within industry (e.g., Kossof, Argos, Econ). The privately financed industry studies are not available to Government agencies. Each study made an assessment of carbon fiber usage based upon projections of cost and technology. These projections are useful in estimating the amount of carbon fiber materials which will enter waste streams. The literature cannot identify values better than those used by the DOT for their Risk Assessment projections. The DOT projects use rates in 1990 at 0.5 kg per automobile and 1 kg per truck; 1995 usage is estimated at 2 kg per automobile and 5 kg per truck.

The processing of scrap carbon fiber composites originating from automotive application remains a speculative area. Scrap from automobiles has the

potential to enter municipal waste streams. Current trends favor recycling and suggest that an increasing proportion of automotive scrap will be reclaimed. The implication is that an equilibrium will develop between the rate of automotive scrapping and the rate of new production. In terms of carbon fiber composite automotive materials entering municipal waste streams, the trend indicates that the primary impact will be from items removed during the life of the vehicle and subsequently discarded in an uncontrolled manner. The volume of discarded materials generated in a locality would be in proportion to the local population of automobiles and trucks.

Industrial Equipment

Carbon fiber composites are being used in special purpose equipment where properties such as resistance to corrosion, inherent lubricity, etc., are required. A variety of molded small parts (gears, bolts, screws, etc.) are presently manufactured. A broad range of experimental industrial applications is under development.

Babcox and Wilcox Company has developed and produces a valve for handling corrosive liquids which utilizes carbon fiber composites (Figure 2-6). The valve permits operation in otherwise unworkable environments; consequently, the valve has found acceptance and enjoys the limited production associated with such specialty items. Carbon fiber manufacturers supply chopped fibers for use in injection molded plastic parts. In addition to the added strength resulting from the reinforcement of the plastic with carbon fibers, many molded products also take advantage of other properties of the fibers, such as self-lubrication. Injection molded parts become bearings, bushings, impellers, gears, cams, guides, etc.. Injection molding of fiber reinforced plastics results in parts with directional mechanical properties. The practical considerations related to flow patterns during the filling cycles effectively limit the kinds of shapes which can be achieved with fiber reinforced, injection molded plastics.

Textile machinery represents an area of promising application potential where the weight and wear properties of composites offer significant advantages. Since Courtauld's, the British firm which developed the basic process for making carbon fibers, is principally in the textile business, such industrial applications have received an emphasis. The items

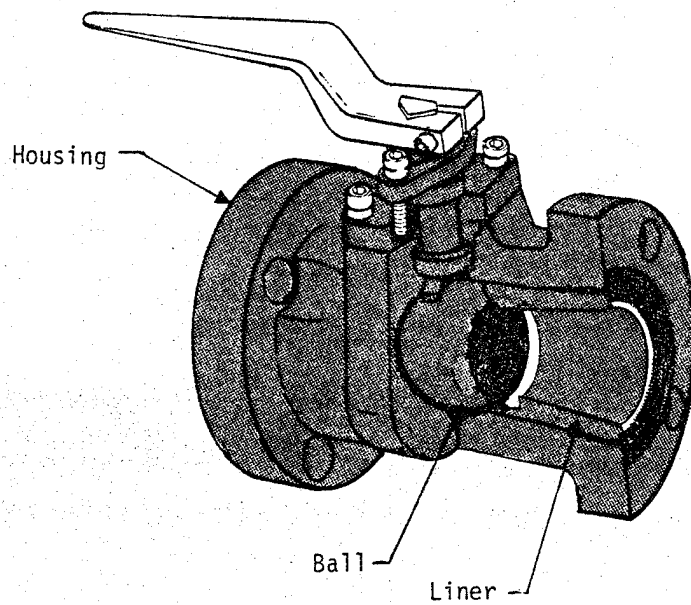

Figure 2-6. Carbon Fiber Composite Valve for Handling Corrosive Liquids.

evaluated include combs for aligning fibers during the cording and spinning processes and drives for the flying shuttles used in high speed looms.

The inherent stiffness and stability of carbon fiber composites have led to their applications in industrial jigs, fixtures and related production tooling. For applications such as assembly jigs or molding forms these composites offer substantial economies in fabrication relative to machined metal.

Application of carbon fiber composites to industrial equipment will show a continuing growth. Each application will be individually justified on the basis of cost effectiveness. Unlike the surface transportation industry, industrial equipment would not see a significant effect as a result of a reduction of the cost of materials. Industrial application will not generate a need to underwrite any major technical advances in the technology for fabrication. Experimental applications will continue with varying degrees of acceptance. As a consequence, industrial discards do not appear as a major source for carbon fibers to enter into waste streams. Industrial scrap usually enters a waste stream under some type of control. On the other hand, the variety of potential applications suggests that carbon fiber composites from industrial equipment will probably have the widest range of shapes, sizes, fiber content and resin systems.

Medical Equipment

The medical uses of carbon fiber composites cover a diversity of applications. These applications could result in a small, but significant, volume of materials which might eventually enter a municipal waste stream. The development of medical uses may give rise to a number of new composite fabricators; eventually, a situation could develop in which practically every major hospital or health care center represented a potential source of carbon fiber materials. The diverse and increasing use of carbon fibers in medical applications includes filamentous carbon used in tendon and ligament repair and carbon fiber composites used for implants, internal repair, prostheses, orthopedic aids and specialized medical furniture.

Because of its superior biocompatibility with body fluids and tissues, untreated filamentous carbon is being investigated for use in tendon and ligament repair. Human testing is now under way on the use of carbon filaments as temporary substrates for

regeneration of collagenous tissue. Eventually, macrophages fragment and remove the carbon.

Orthopedics presents a promising area for application of carbon fiber composites (Figure 2-7). These materials are being studied relative to use as: joint replacements or coatings for joint replacements; internal plates for repair of bone fractures; reinforcing bone cements; orthopedic aids and rehabilitative devices. Results of investigations of the use of carbon fiber-reinforced cement in repair of dentures indicate that these cements could be used for a variety of bone repairs. Mechanical supports making use of carbon fiber composites include wheelchairs, crutches, leg braces, damping braces (for cerebral palsy victims). In addition, external supports (casting forms, splints, and carbon-glass cloth) are used for support of weakened muscles or to improve stability of mechanically impaired joints. Prostheses, including artificial legs and a powered hand for communication with deaf-blind individuals, are also under development.

Medical furniture would benefit from the light weight and low X-ray absorption characteristics of carbon fibers. These include table tops for X-rays, angiographic compression plates, and support couches.

The level of control of disposal of carbon fiber composites in the medical industry is expected to be high. Some material could enter the municipal waste stream when an individual discards a worn out or outgrown device. Most articles (e.g., splints, casts, prostheses, walkers, etc.) would be removed by qualified medical personnel.

Aircraft

Applications of carbon fiber composites to aircraft, particularly military, have provided the driving force for the development of technology for both the manufacture of fiber and the fabrication of structure. The approach to utilization has been gradual. Carbon fiber composites were first used in non-critical, secondary (bolt-on or movable) structures such as hatch covers, doors, speed brakes and wing fairings. The experience gained in both manufacture and subsequent flight operations provided the evaluation data for improvements in the technology such that military aircraft will now utilize such composites in primary structure such as wing panels and spars.

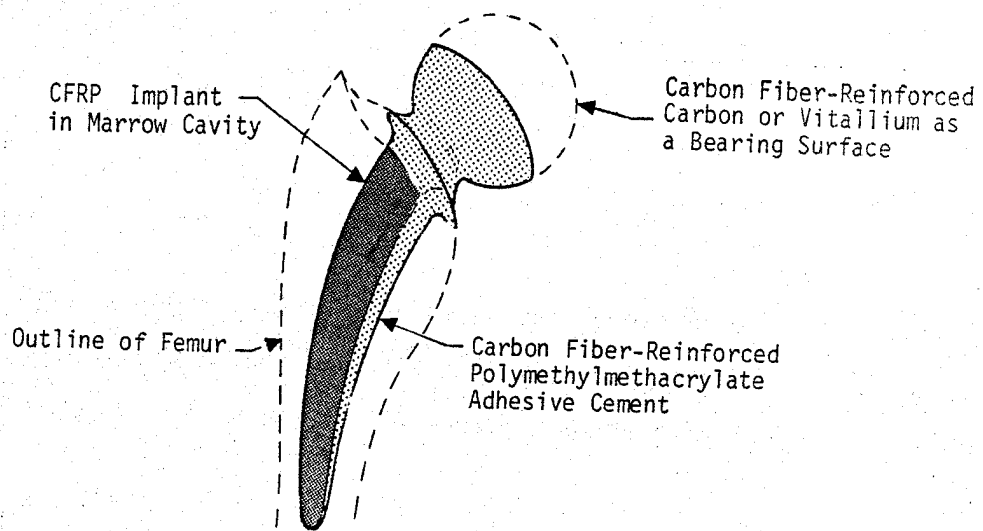

Figure 2-7. Carbon Fiber Based Composite Application to an Artificial Hip Joint Implant

Table 2-4 traces the principal applications of carbon fiber composites to aircraft. For the U.S. Air Force, the F-16 is the first design-from-the-start application for carbon fiber composites. Previous aircraft utilized carbon fiber components as updates for existing composite configurations. The U.S. Navy F-18 Hornet (Figure 2-8) makes the first critical utilization of carbon fiber composites; without their weight advantage, the aircraft could not achieve an acceptable performance. The production envisioned for this aircraft would become the first commitment of more than 1,000,000 pounds of carbon fiber composites to a single airplane program. A decision to build the AV-8B vertical takeoff fighter for the U.S. Marine Corps and the United Kingdom would also result in the commitment of 1,000,000 lbs.; however, the production would be divided between the U.S. and the U.K.

The NASA, Langley Research Center, through the Aircraft Energy Efficiency (ACEE) Project, has provided technical leadership in the application of carbon fiber composites to civil transport aircraft. These efforts involved the development of secondary structure elements for flight evaluation as spoilers, elevators, rudders, and ailerons. The continuing efforts involve primary structure such as horizontal stabilizers and vertical stabilizers. The manufacturers of transport aircraft envision an expanding utilization for carbon fiber composites. The increasing costs for fuel have added an urgency to their plans. The Boeing 767 represents the first transport configuration to incorporate carbon fiber composites as part of the original design. The builders of airplanes intended for business flying are responding to the increase in fuel costs by designing carbon fiber composites into their newest models (Cessna, Lear Avia). The problems and delays associated with obtaining an FAA certification appears as the principal limiter for applications to new designs for business aircraft.

The expanding utilization planned by the manufacturers of transport aircraft presently concentrate on empennage, wing fairings, movable controls and floor panels. As design and technology mature, use will be extended to other elements. Lockheed has presented the most ambitious goal as a complete wing structure for the L-1011.

Projections for 1990 show transport aircraft employing nearly 6,000,000 pounds of carbon fiber composites distributed over a nominal fleet of 3,000 airplanes. General aviation will follow the same

TABLE 2-4. SUMMARY OF PRINCIPAL AIRCRAFT APPLICATIONS FOR CARBON FIBER COMPOSITES

<u>MILITARY AIRCRAFT</u>	<u>NO. OF A/C</u>	<u>COMPONENTS</u>	<u>LBS. OF CF</u>	<u>COMMENTS</u>
F-4 Phantom McDonnell-Douglas	4	Access doors	5 per A/C	Evaluation Program, USN
S-3 Viking Vought	10	Lower spoilers	8.6 per item	Evaluation Program, USN
A-7 Corsair Vought	7	Wing panels	50 per item	Evaluation Program, USN
F-111 General Dynamics	200	Wing fairings	20 per item	Production item for later aircraft, including all F-111C units delivered to Australia. USAF
F-15 Eagle McDonnell-Douglas	200	Speed brakes and empennage elements	~160 per A/C	Recent and current production 100/yr. USAF
F-16 General Dynamics	A11	Empennage	~160 per A/C	Planned as a production item at concept. USAF
F-18 Hornet McDonnell-Douglas	A11	Wing panels, flaps, empennage, doors (See Figure 2-8.)	>1000 per A/C	Design of aircraft dependent on use of carbon fiber composites. USN
AV-8B Harrier McDonnell-Douglas	A11	Wing, forward fuselage	>1000 per A/C	Prototype only to date. Production pending for USMC and United Kingdom.
<u>CIVIL AIRCRAFT</u>				
737, Boeing	27	Spoilers (4)	52 per A/C	NASA sponsored long term flight evaluation program in airline service.
DC-10 McDonnell-Douglas	8	Upper aft rudder	~30 per item	

TABLE 2-4. CONT. SUMMARY OF PRINCIPAL AIRCRAFT APPLICATIONS FOR CARBON FIBER COMPOSITES

CIVIL AIRCRAFT	NO. OF A/C	COMPONENTS	LBS. OF CF	COMMENTS
727, Boeing	10	Elevators	~65 per A/C	Joint NASA-Industry program, presently beginning flight evaluation in airline service.
DC-10 McDonnell-Douglas	10	Upper aft rudder	~30 per A/C	
L-1011, Lockheed	10	Ailerons	~80 per A/C	
737, Boeing	1	Horizontal Stabilizer	~100 per A/C	
DC-10 McDonnell-Douglas	2	Vertical Stabilizer	~330 per A/C	Joint NASA-Industry program. Components are in fabrication for ground test and flight evaluation. Not in airline service.
L-1011, Lockheed	1	Vertical fin	~350 per A/C	
747, Boeing	42	Floor panels	~200 per A/C	Recent and current production. 32 identified as not U.S. carriers.
767, Boeing	All planned (~200 ordered)	Control surfaces, engine cowls, fairings, landing gear doors	~2000 per A/C	Advertised performance depends upon use of carbon fiber composites.
Citation III Cessna	All planned ~100	Flaps, fairings, engine cowlings, landing gear doors	~150 per A/C	Aircraft in certification.
Lear Fan Lear Avia	All planned (120 on order)	Fuselage structure, wing structure, empennage, control surfaces, propeller	>500 per A/C (est.)	Prototype will fly late 1980.

TABLE 2-4. CONT. SUMMARY OF PRINCIPAL AIRCRAFT APPLICATIONS FOR CARBON FIBER COMPOSITES

<u>OTHER AIRCRAFT</u>	<u>NO. OF A/C</u>	<u>COMPONENTS</u>	<u>LBS. OF CF</u>	<u>COMMENTS</u>
CH-46 CH-47 Boeing Helicopters	4 1	Main rotor blades	~70 per A/C	Evaluation of application to helicopters.
S-63 Sikorsky LAMPS UTTAS	All planned 200	Tail rotor, fuselage panels	~50 per A/C	Helicopter in early production.
S-73 Sikorsky (Civil Model of S-63)	All planned (est. 100)	Tail rotor, door panels	~50 per A/C	Tail rotor shaft later option. Prototype production, 3 A/C.
Space Shuttle Orbiter	All (5 planned)	Propulsion pods, nose cap, cargo pallets, wing leading edge support structure cargo bay doors (8)	~5000 per A/C	Later production units may increase utilization to include flaps, fairings, access doors and horizontal, vertical stabilizer.

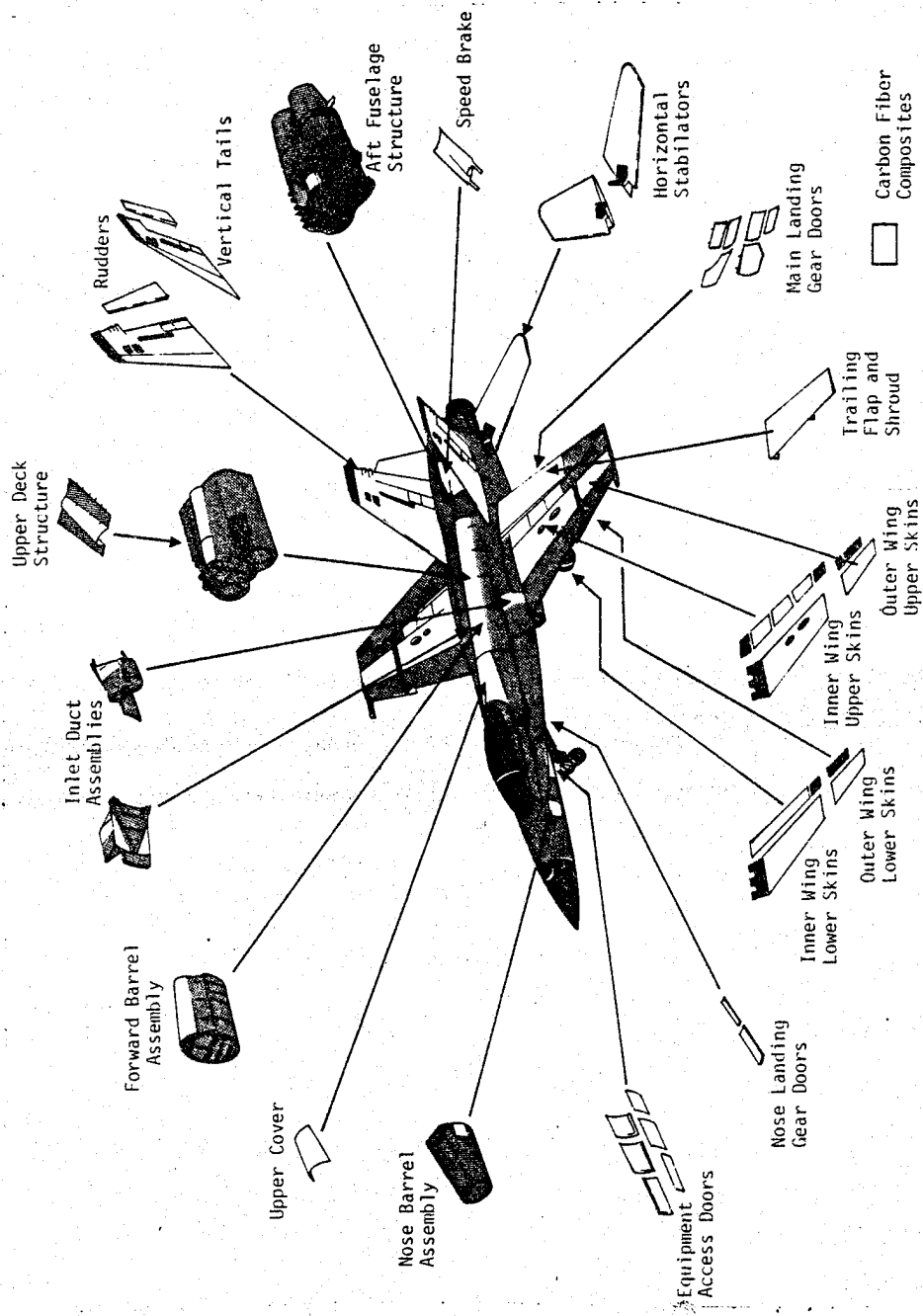

Figure 2-8. Application of Carbon Fiber Based Composites to the U.S. Navy F-18 Fighter.

pattern on a smaller scale; projected 1990 usage approaches 1,000,000 lbs.

Foreign aircraft applications follow the U.S. pattern. Fighter planes under development in Germany, France and Sweden utilize varying amounts of carbon fiber composites. Differences between the American and European usage have tended to disappear, since European firms supply components to American aircraft. For example, the floor panels for the Boeing 747 are fabricated by Bristol of England.

Experimental applications for aircraft have looked at all forms of booms, struts, drive shafts, and gearbox housings, and extended into blading for both engines and helicopters. Some of these designs have matured to the extent that carbon fiber tail rotors are now in use in helicopters and tail rotor drive shafts will be operational in the near future.

The disposal of carbon fiber composites in aircraft was not addressed in the literature. For U.S. private aircraft, accidents represent the single significant loss to the fleet; the growth rate of the fleet almost matches the annual production rate. Accidents are a significant loss for military aircraft, particularly fighters. However, the military have well-established procedures for handling obsolete or non-useable aircraft. Transport aircraft eventually reach some limit such as fatigue and enter into a scrap-out process. The service life for carbon fiber composites has not been defined, but present practices suggest change-out as part of routine maintenance. Disposal of carbon fiber-based composites in aircraft may come into equilibrium with production over the course of the next two decades. A requirement for disposal at a rate equal to production seems a reasonable projection for the end of the century. It can be recognized that large pieces of transport aircraft will eventually present some problems in disposal. The vertical fin on an L-1011 has envelope dimensions of the order 30 feet by 20 feet by 2 feet. Such an item must be cut into manageable pieces as part of the scrapping operation. While the process may have complexities, aircraft scrap is not expected to appear on the tipping floor of a municipal incinerator unanticipated and concealed within the load on a garbage truck.

Space and Missiles

The applications of carbon fiber composite to space vehicles and missile systems parallel applications to

aircraft. For space vehicle applications, the thermal properties of the carbon fibers add a further attraction beyond light weight and stiffness. The near-zero coefficient of thermal expansion and the resistance of the graphite molecular structure to degradation by radiation makes these materials very attractive for orbiting vehicles which operate in a charged particle environment and are exposed to hundred-or-more-degree thermal shocks as the vehicles pass through the shadow of the earth.

The orbiter portion of the Space Shuttle epitomizes applications to space vehicles. The cargo bay doors and experiment support pallets within the cargo bay are constructed from carbon fiber-based composites. The weight advantage afforded by the use of carbon fibers gives the orbiter a useable payload capacity. At the time of construction, the eight individual elements which comprise the total door system were among the largest units ever fabricated from carbon fiber composite (dimensions $\sim 5\text{m} \times 3\text{m}$ each).

The dimensional stability exhibited by carbon fiber composites has resulted in a continuing application to structural elements of space-borne antennas. Space antennas generally require dimensional control of surface imperfections to the order of a tenth of a wave length. Such considerations lead to tolerance requirements of 1 centimeter over surfaces up to 10 meters in diameter. Carbon fiber composites can provide such accuracies.

Development of the Space Shuttle System will permit building structures in space from building blocks ferried by a series of shuttle launches. The NASA has identified 42 such missions. The most tantalizing of these missions would be to construct a large collector for converting solar energy to radio waves. These would be beamed to earth, where they would be received and converted to electrical power. The NASA, Langley Research Center, through the Large Space System Technology (LSST) program, has the responsibility of coordinating research and development efforts in support of future missions which will require large structures in space (Figure 2-9). Communications, weather and earth resource missions appear both practical and beneficial in the near term. These programs will utilize carbon fiber composites. The LSST activities will require approximately 10 years of development before the erection of the first large structures in space. At that time, the volume of

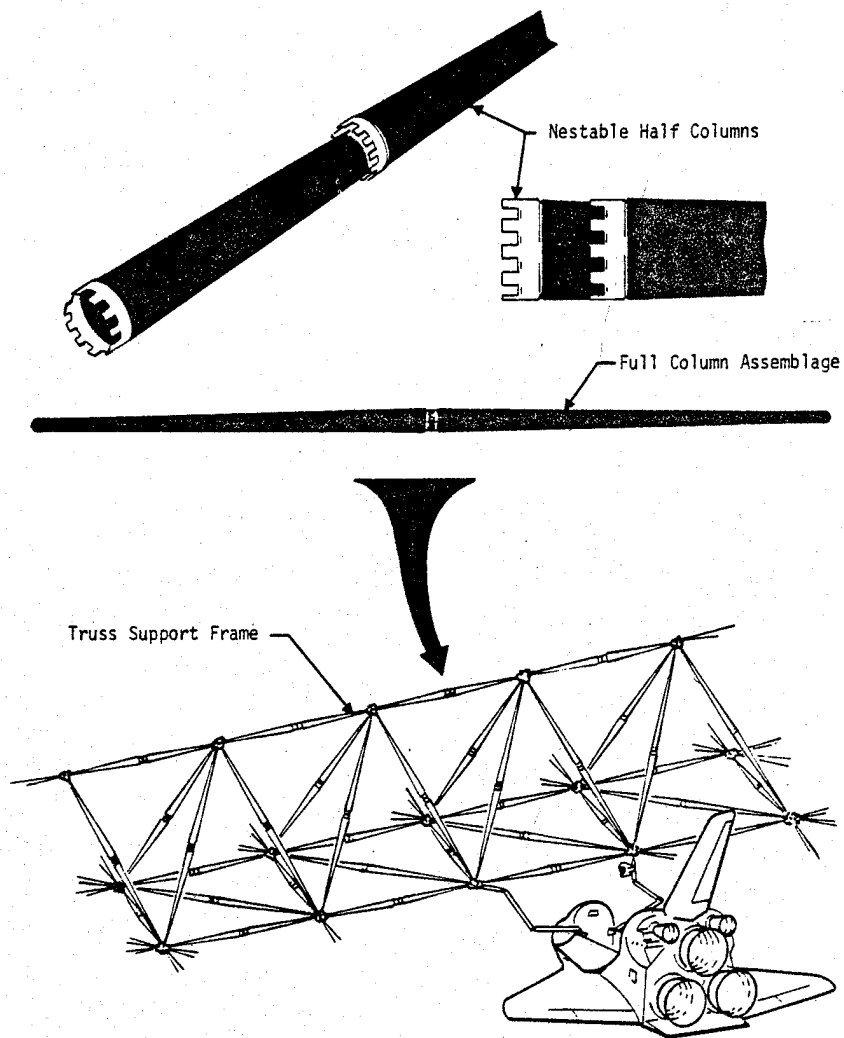

Figure 2-9. Carbon Fiber Nestable Columns for Building Large Space Structures.

space and missile utilization of carbon fiber composites may match the usage in aircraft.

Although materials lofted into space will never enter a waste stream, development efforts will result in a volume of composites for use in ground-based tests. A presently undefinable portion of total aerospace usage will enter waste streams in the form of spent test units or production scrap. The majority of these items will originate from industrial or Government laboratory facilities, where controls exist. The possibility exists that a small (presently not predictable) portion of these development items may find their way into municipal waste streams.

Carbon fiber-based composites have applications to booster rocket structure and to structures within missiles, for example, vehicles and nose-cones. A related material, known as carbon-carbon, together with pyrolytic graphite, is used in heat shields and nose tips on re-entry vehicles. The carbon fibers used in carbon-carbon systems generally do not exhibit a graphitic microstructure. The resin system utilizes a phenolic base. In the manufacturing process, the final steps take the entire lay-up into a temperature range which pyrolyzes the phenolic and leaves only a carbon structure. These materials ablate when heated and do not release fibers. Carbon-carbon systems have excellent insulating characteristics under conditions of high temperature and high heat fluxes. As a consequence, these material systems are finding additional applications as the friction pads in aircraft brakes. Again, the product of a heat exposure is fine dust rather than fiber.

APPLICATIONS

BIBLIOGRAPHY

1. Betz, R. O. Composites Poised for Plunge into Auto Materials Pool, Iron Age. March 21, 1977, pp. 58-61.
2. Bonnett, R. E., Kulkarni, H., Lim, G., Beardmore, P., and Knight, R. Design and Fabrication of Automotive Components in Graphite Fiber-Reinforced Composites. SAE Pub. No. 790031, Society of Automotive Engineers, 1979.
3. Bushman, E. F., and Bushman, G. R. Carbon-Fiberglass-Polymer Composites for Electrical Tooling and Parts...A "Sleeping Beauty". Proceedings of the Thirty-third Conference Reinforced Plastics/Composites Institute, Washington, D.C. Feb. 7-10, 1978, The Society of the Plastics Industry, Inc., 1978, Section 21-F, pp. 1-6.
4. Deutsch, G. C. Automotive Applications for Advanced Composite Materials. Proceedings of the 23rd National SAMPE Symposium and Exhibition, Anaheim, California, May 2-4, 1978, SAMPE, 1978, pp. 34-59.
5. Dharan, C. K. H., and Thoms, J. Selection Criteria for Advanced Composites Automotive Chassis Systems. Proceedings of the 24th National SAMPE Symposium and Exhibition, San Francisco, California, May 8-10, 1979, SAMPE, 1979, pp. 1550-1566.
6. Faddoul, J. R. Preliminary Evaluation of Fiber Composite Reinforcement of Truck Frame Rails, SAE Pub. No. 770898, Society of Automotive Engineers, 1977.
7. Hastings, G. W. Carbon Fibre Composites for Orthopaedic Implants, Composites, July, 1978. pp. 193-197.
8. Haines, D. W. and Chang, Nagyoung. Making Better Musical Instruments from Graphite Composites, Mechanical Engineering, March 7, 1976. pp. 25-27.
9. Jenkins, G. M. and de Carvalho, F. X. Biomedical Applications of Carbon Fibre Reinforced Carbon in Implanted Prostheses, Carbon, 1977. Vol. 15, pp. 33-37.

10. Kaiser, Robert. Technology Assessment of Automotive Uses of Advanced Composite Materials. Proceedings of the 24th National SAMPE Symposium and Exhibition, San Francisco, California, May 8-10, 1979, SAMPE, 1979, pp. 904-915.
11. Krouse, John K. Injection-Molded Carbon-Fiber Composites, Machine Design, August 9, 1979. pp. 79-85.
12. Larson, G. C. Composite Materials and General Aviation, Business and Commercial Aviation, September, 1979, pp. 86-98.
13. LeCerf, B. H. and Greene, A. M. Advanced Materials Given Room to Fly in Aerospace, Iron Age, June 19, 1978, pp. 53-62.
14. Leopold, P. M. Advanced Composite Graphite/PPS Valve for High Temperature Strength and Corrosion Resistance. Proceedings of the 23rd National SAMPE Symposium and Exhibition, Anaheim, California, May 2-4, 1978, SAMPE, 1978. pp. 651-652.
15. Margolis, J. M. Automotive Developments in the 1980's: Composites vs. Metals, SAMPE Journal, July/August, 1980. pp. 7-15.
16. Mayfield, J. Carbon Fiber Replacements Developing, Aviation Week & Space Technology, January 22, 1979. pp. 49-52.
17. McKenna, G. B., Statton, W. O., Dunn, H. K., Johnson, K. D., Bradley, G. W., and Daniels, A. U. The Development of Composite Materials for Orthopedic Implant Devices. Proceedings of the 21st National SAMPE Symposium and Exhibition, Los Angeles, California, April 6-8, 1976, SAMPE, 1976. pp. 232-240.
18. Miska, K. H. From Wimbledon to Watkins Glen Advanced Composites Play the Game, Materials Engineering, Vol. 87, June, 1978. pp. 21-23.
19. Miska, K. H. Detroit Looks to Advanced Composites to Shed Weight, Improve Fuel Economy, Materials Engineering, September, 1977. pp. 66-68.
20. Molyneux, M. and Lyons, B. R. Carbon Fiber Reinforced Plastics Parts in Radiological Equipment. Proceedings of the Thirty-third Annual Conference Reinforced Plastics/Composites Institute, Washington, D. C. February 7-10, 1978. The Society of the Plastics Industry, Inc., 1978, Section 12-E. pp. 1-12.

21. Post, C. T. Composites Reshape Sports Equipment Field, Iron Age, July 31, 1978. pp. 41-45.
22. Prunty, Jack. Dimensionally Stable Graphite Composites for Space Structures, SAMPE Quarterly, January, 1978. pp. 41-51.
23. Sidwell, D. R., Torczyner, R. D., Yates, D., Motwani, M. B., and Thoms, J. L. Graphite-Reinforced-Plastic Passenger Car Frame, SAE Pub. No. 790030, Society of Automotive Engineers, 1979.
24. Sliney, H. E. and Jacobson, T. P. Graphite-Fiber-Reinforced Polyimide Liners of Various Compositions in Plain Spherical Bearings, ASLE Proceedings, 2nd International Conference of Solid Lubrication 1978, American Society of Lubrication Engineers, 1978. pp. 258-261.
25. Vasilash, Gary S. Advanced Composites: Yesterday, Today, and Tomorrow, Manufacturing Engineering, February, 1978. pp. 60-64.
26. Critical Space Telescope Unit Tested, Aviation Week & Space Technology, July 7, 1980. pp. 43.
27. Gossamer Albatross: Anatomy of a Cross-Channel Flier, FLIGHT International, July 28, 1979. pp. 258-262.

2.5 RESEARCH

Based on the publications reviewed in the Literature Search, recent and ongoing research in both the United States and Overseas has emphasized the application of carbon fiber composites, particularly to aerospace equipment. These applications have necessitated investigations of composite properties, analytical techniques for quality control, and design and fabrication technologies and methods. A relatively small research effort, in terms of publications, has been directed at properties and production methods for resins and carbon fibers. Table 2-5 is representative of research interests in each of the above areas.

TABLE 2-5 AREAS OF RESEARCH

	United States	Overseas	USSR
APPLICATION	>250	84	-
COMPOSITE PROPERTIES	77	75	13
ANALYTICAL TECHNIQUES	27	20	2
DESIGN AND FABRICATION	18	7	-
RESINS	14	8	1
CARBON FIBERS	8	14	1
TOTALS	>394	208	17

Efforts in the United States and Overseas are essentially similar in terms of emphasis. The total American effort is roughly twice as great as that of all overseas countries. Russian efforts, particularly in terms of application and design and fabrication, are conspicuously absent, suggesting a heavy screening imposed for security reasons.

Table 2-6 is a more detailed comparison of efforts by the U.S., Overseas countries, and the USSR.

TABLE 2-6. COMPARISON OF RESEARCH EFFORTS

AREA OF RESEARCH	COUNTRY	
	United States Overseas	U.S.S.R
Carbon Fibers	8	14
Resins	14	8
Designs & Fabrication	18	7
Composite Properties		
A. Mechanical	39	46
B. Thermal	12	16
C. Wear	4	5
D. Fluid Interaction	14	8
E. Electrical & Other	8	-
Analytical Techniques	27	20
Applications		
A. Aircraft	>100	51
B. Space	>100	15
C. Other	>50	18
TOTAL	>394	208
		17

Carbon fiber efforts have concentrated primarily on the development of better or less expensive methods of producing carbon or graphite fibers. Some studies have been done on the physical properties of the fibers.

Studies of resins have been aimed at developing resin systems for binding carbon fibers which are compatible with application or production techniques. Thermal, chemical and other studies of various resin systems have been conducted. Investigations of resin systems with rapid cure cycles have also been undertaken, particularly aimed at use in high piece rate applications, such as in the automobile industry.

Design and fabrication technology and equipment have been studied, both in terms of cost effectiveness and the effect of layup and fabrication methods on the structural integrity of the final part.

A major area of investigation has been the properties of the composite of carbon fibers and an appropriate binder resin system. These include: mechanical properties of the composite; thermal and wear characteristics; the compatibility of the composite with liquids (particularly moisture absorption and ability to withstand exposure to fuels and kerosene); and electrical and other properties of the composite.

Once a composite piece has been produced (for example, a speed brake for an airplane), it is necessary to inspect the part for structural integrity, ratio of fibers to matrix material, presence of voids, and so on. This need has given rise to a body of literature on analytical techniques for non-destructive testing of finished goods. Likewise, in the design and development of a composite part, predictive tools for determining strength and performance capability have been developed; these are included under the heading of analytical techniques.

The largest area of published research is concerned with the application of carbon fiber composites to a variety of uses. Foremost among these is the use of carbon fiber composites in aerospace. Both American and Overseas researchers have extensively investigated the applications to aircraft, both civilian and military. Space applications include large structures, such as space antennas, solar collectors and orbiting platforms.

Other areas of applications research include automotive, medical and industrial. The volume of publications in these research areas is probably somewhat influenced by the practices of the industry; for example, the medical profession

TABLE 2-7. OVERSEAS RESEARCH EFFORTS BY COUNTRY

AREA OF RESEARCH	GREAT BRITAIN	GERMANY	NETHERLANDS	FRANCE	JAPAN	AUSTRALIA	SWEDEN	ITALY	ISRAEL	CANADA	INDIA	BELGIUM	TOTALS
Carbon Fibers	3	3	1	2	4	-	1	-	-	-	-	-	14
Resins	5	-	1	2	-	-	-	-	-	-	-	-	8
Design & Fabrication	3	4	-	-	-	-	-	-	-	-	-	-	7
Composite Properties													
A. Mechanical	12	10	11	2	3	2	2	1	2	1*	-	-	46
B. Thermal	4	1	4	1	5	-	-	-	1	-	-	-	16
C. Wear	2	1	-	-	1	-	-	-	-	-	-	1	5
D. Fluid Interaction	5	-	1	-	1	1	-	-	-	-	-	-	8
Analytical Techniques	5	3	3	4	-	-	1	1	-	1*	2*	-	20
Applications													
A. Aircraft	21	19	2	3	2	1	2	1	-	-	-	-	51
B. Space	-	8	-	4	-	1	-	2	-	-	-	-	15
C. Other	10	2	-	1	2	2	-	1	-	-	-	-	18
TOTALS	70	51	24	19	18	7	6	6	3	2	2	1	208

(* - jointly with Great Britain)

has a history of publishing ongoing research; the automotive industry, on the other hand, might be a little more reticent about publication of information which could compromise a competitive edge in the market place.

OVERSEAS RESEARCH

The Literature Search identified twelve overseas countries (exclusive of the U.S.S.R.) involved in the publication of carbon fiber research. The breakdown, by country and area of research, is presented in Table 2-4. Great Britain and West Germany have undertaken large scale research covering the complete range of research interests. The distribution of research among the areas is similar to that of the United States.

In terms of number of publications, France, Japan, and the Netherlands form a second grouping; the total of all three countries is roughly equal to that of West Germany. Japan's investigation into carbon fibers, per se, is large as a proportion of the total research effort. Included in the Japanese research is an investigation of the use of copper-coated carbon fibers as electrical transmission cables.

Sweden and Australia have each conducted research primarily on mechanical properties of composites and aircraft application. Israel, Italy, Canada, Belgium, and India show only a few publications, and the Canadian and Indian efforts were conducted jointly with Great Britain.

As in the U.S., Overseas research is strongly oriented toward the aircraft industry. Developments such as the European Airbus and the English-French Concorde have been multinational; much of the European research may be assumed to share this multinational character. These international interrelationships extend to the U.S., as portions of American aircraft are built overseas.

By and large, both quantitatively and qualitatively, Overseas research efforts reflect the involvement of the individual country in aircraft design and production. Japanese efforts appear to be more focused on the production of carbon fibers for export markets.

SUPPORT OF RESEARCH

Although the functional units performing research -- government agencies, private industry, and universities -- are the same in the U.S. and Overseas, the degree of involvement of each reflects the political and economic system of the particular country. In the U.S., Federal agencies supply funding and direction of the research efforts, particularly during the initial stages of development. Technically oriented agencies (e.g., NASA) are involved in the performance of research; in many cases, the effort is carried out under grants or contracts to universities and private industry. Private corporations with a vested interest in the development of carbon fiber composites (aircraft and automobile manufacturers, sporting goods producers, etc.) continue to underwrite research costs applicable to their products.

Overseas, government agencies perform a more direct role in the conduct of research programs. The inter-relationship between government, industry and universities is not as clear cut as in the U.S. As a result, the involvement of government agencies in breadth and scope tends to be greater Overseas.

RUSSIAN RESEARCH

It is anticipated that Russian efforts relative to carbon fiber composites are directed toward aerospace and other defense related applications. However, review of the translated literature reveals no publications directed toward applications. Only seventeen articles relating to carbon fibers and composites were available, and these concentrated on mechanical properties of composites, with only a few publications relating to analytical techniques, thermal properties, fibers and resins. The American military services monitor available Russian publications, and translate materials with potential applicability or usefulness; thus, significant Russian technical publications relating to carbon fibers or composites are likely to be available in English.

RESEARCH
BIBLIOGRAPHY

SOCIETY FOR THE ADVANCEMENT OF MATERIAL AND PROCESS ENGINEERING
(SAMPE)

The Enigma of the Eighties: Environment, Economics, Energy,
Proceedings of the 24th National SAMPE Symposium and Exhibi-
tion, San Francisco, California, May 8-10, 1979

- Gibbs, H., NR-150AZ The 500° F Binder with Epoxy-Type
Moldability, pp. 11-20
- Hartness, J. and Husman, G., Polyphenyl Sulfone Matrix
Composites, pp. 21-30
- Edler, V., Mace, W., Sepes, C., and Wereta, A., High
Temperature High Complexity Graphite Polyimide Part
Manufacturing, pp. 217-231
- Sanjana, Z., Overage Indicators for Prepreg Products,
pp. 330-341
- Elberg, R., F.O.C. Optical Bench: An Application of the
Low Thermal Expansion Property of Carbon Fiber
Composites, pp. 1310-1320 (FRANCE)

Selective Applications of Materials for Products and Energy,
Proceedings of the 23rd National SAMPE Symposium and Exhibi-
tion, Anaheim, California, May 2-4, 1978

- Arnold, F., Lockerby, S., Loughtan, G., and Maximovich,
M., Acetylene Terminated Sulfone (ATS) A New
Composite Matrix Resin, pp. 490-498
- Byon, O., Vemura, M., Optimal Design of Fiber Composite
Flywheels Reinforced Besides Circumferentially...
Filament Wound Construction, pp. 728-739 (JAPAN)
- Block, B., Ropars, M., PSP Resins, New Thermosetting
Binders for Advanced Composites, pp. 836-839 (FRANCE)
- Worthington, P., Composite Material Flywheels for Energy
Storage on Electricity Supply Systems, pp. 846-851.
(GREAT BRITAIN)

- Ishai, O., Molcho, A., (1978) Thermal Cracking of C.F.R.P. Laminates, 10th National SAMPE Technical Conference, Vol. 10: 255-258 (ISRAEL)
- Hoggatt, J., Oken, S., (1977) Behavior of Graphite Composites in a Marine Environment, 9th National SAMPE Technical Conference, Vol. 9: 111-120
- Judd, N., Mathews, B., Pritchard, G., Stokes, F., (1977) The Effect of Aviation Fluids on Carbon/Epoxy Composite Panels, SAMPE Journal, Vol. 13: 10-15 (GREAT BRITAIN)
- Norman, J., Zweben, C., (1976) Kevlar 49/Thornel 300 Hybrid Fabric Composites for Aerospace Applications, July, Vol. 7: 1-10

JOURNAL OF COMPOSITE MATERIALS

- Loos, A., Springer, G., (1979) Effects of Thermal Spiking on Graphite-Epoxy Composites, Vol. 13: 17-34
- Loos, A., Springer, G., (1979) Moisture Absorption of Graphite-Epoxy Composite Immersed in Liquids and in Humid Air, Vol. 13: 131-147
- Kobayishi, S., Koyama, K., (1978) Thermal Expansion Coefficients of Unidirectional Composites, Vol. 12: 153-168 (JAPAN)
- Ishikawa, T., Kobayishi, S., Koyama, K., (1977) Elastic Moduli of Carbon-Epoxy Composites and Carbon Fibers, Vol. 11: 332-344 (JAPAN)
- Kamp, J., van Dreumel, W., (1977) Non-Hookean Behaviour in the Fibre Direction of Carbon-Fibre Composites and the Influence of Fibre Waviness on the Tensile Properties, Vol. 11: 461-469 (NETHERLANDS)

JOURNAL OF MATERIALS SCIENCE

- Fischback, D., Gilbert, D., (1979) Dimagnetic Characterization of Carbon Fibres from Pitch Mesophase, Pitch and Polyacrylonitrile, Vol. 14: 1586-1592
- Fisher, S., Marom, G., Tuler, F., Wagner, H., (1978) Hybrid Effects in Composites - Conditions for Positive or Negative Effects Versus Rule-of-Mixtures Behavior, Vol. 13: 1419-1426 (ISRAEL)
- Barry, P., (1978) The Longitudinal Tensile Strength of Unidirectional Fibrous Composites, Vol. 13: 2177-2187 (AUSTRALIA)

JOURNAL OF MATERIALS SCIENCE (cont.)

- Favre, J., (1977) Improving the Fracture Energy of Carbon Fibre-Reinforced Plastics by Delamination Promoters, Vol. 12: 43-50 (FRANCE)
- Briggs, A., (1977) Review of Carbon Fiber Reinforced Cement, Vol. 14: 384-404 (GREAT BRITAIN)

COMPOSITES

- Tretout, H., White, R., (1979) Acoustic Emission Detection Using a Piezoelectric Strain Gauge for Failure Mechanism Identification in CFRP, Vol. 10: 101-109 (GREAT BRITAIN)
- Caprino, G., Halprin, J., Nicolais, L., (1979) Fracture Mechanics in Composite Materials, Vol. 10: 223-227 (ITALY)
- Owston, C. M., Prakash, R., (1977) Ultrasonic Determination of Lay-up Order in Cross-plyed CFRP, Vol. 8: 100-102 (INDIA)
- Gerharz, J., Schuetz, D., (1977) Fatigue Strength of a Carbon-Fiber Reinforced Material --- CFRP, Vol. 8: 245-250 (GERMANY)

POLYMER ENGINEERING AND SCIENCE

- Jakubowski, J., Subramanian, R., (1978) Electropolymerization on Graphite Fibers, Vol. 18, No. 7, pp. 590-600
- McGarry, F., Sung, N., (1976) The Mechanical and Thermal Properties of Graphite Fiber Reinforced Polyphenylquinoxaline and Polyimide Composites, Vol. 16, No. 6, pp. 426-436

AMERICAN INSTITUTE OF AERONAUTICS AND ASTRONAUTICS (AIAA)

- AIAA/ASME 18th Structures, Structural Dynamics and Materials Conference, 1977
- Cook, T., Preston, J., Impact Behavior of Graphite-Epoxy Simulated Fan Blades, Vol. A: 49-57.
- Derby, E., Bohlman, R., Moisture Diffusion in Graphite-Epoxy Laminates: Experimental and Predicted, Vol. A: 219-226

SECOND INTERNATIONAL CARBON CONFERENCE, Baden-Baden, 1976

Dezarov, I., Marinkovic, S., Raskovic, V., Air Oxidation
Replaced by SO₂ Treatment in PAN-Precursor-Carbon-Fibres
Preparation, pp. 121-125 (GERMANY)

Rose, P., Fracture of High Modulus Carbon Fibers, pp. 294-297
(GERMANY)

JOINTING IN FIBRE REINFORCED PLASTICS, Proceedings of the
Symposium, London, England, Sept. 4-5, 1978

Cotter, J., Surface Preparation of Titanium for Bonding to
Carbon Fibre Reinforced Plastics, pp. 87-94
(GREAT BRITAIN)

Parker, B., The Effect of Hot-Humid Conditions on Adhesive-
Bonded CFRP-CFRP Joints, pp. 95-103 (GREAT BRITAIN)

Kingston-Lee, D., Phillips, L., Rogers, K., The Application
of Reinforced Plastics to the Emergency Repair of
Aircraft, pp. 104-115 (GREAT BRITAIN)

REINFORCED PLASTICS/COMPOSITES INSTITUTE, Proceedings of the
Thirty-third Annual Conference, Washington, D. C.,
Feb. 7-10, 1978

Gibbs, Hugh H., Wendt, Robert C., Wilson, Frank C., Carbon
Fiber Structure and Stability Studies, The Society of
the Plastics Industry, Inc., Sec. 24-F, pp. 2-9

OTHER SOURCES:

Japan Society of Materials Science Journal

Asmeccanica and Associazione Meridionale di Meccanica,
Convengo Nazionale sui Materiali Compositi, Milan,
Italy, May 11-13, 1978

Deutsche Gesellschaft fuer Luft-und Raumfahrt, Symposium
Proceedings

U.S.S.R. RESEARCH

BIBLIOGRAPHY

1. Ermolenko, I., Malashevich, Zh., Malkov, A., Sviridova, R. (1979) Study of the Effects of a Low-Temperature Plasma on Carbon Fiber Materials. *Akademiia Nauk BSSR, Doklady*. Vol. 231, No. 6:533-535.
2. Gaidachuk, V., Pilnik, A., Rassokha, A. (1977) Experimental Investigation of the Abrasive Wear Resistance of Composites. *Samoletostronenie-Tekhnika Vozdushnogo Flota*. No. 41:71-74.
3. Kudriavtsev, A., Ulianenko, A., Umanskii, E. (1979) Study of the Combined Effect of Temperature, Environmental Moisture, and Fiber Orientation on the Strength of Glued Carbon-Plastic Joints. Strength of Materials. Vol. 10, No. 10:1185-1187.
4. Makhmurov, I., Polilov, A. (1976) Strength Criteria for Orthogonally Reinforced Composites with Polymer Matrix. *Mekhanika Tverdogo Tela*, pp. 160-169.
5. Kulakov, V., Lukina, E. (1976) Carbonization Process in Compounds Based on Carbon Fibers and Furane Binders. *Khim. Tverdogo Topliva*. No. 6:63-66.
6. Golikova, L., Guniaev, G., Kobets, L., Lysenkova, T., Prigorodov, V. (1976) Surface Treatment of High Modulus Fillers---for Carbon and Boron Fiber Composites. *Fibrous Dispersion-strengthened Composite Materials*, pp. 159-165.
7. Antonov, A., Arkhipov, P., Fedoseev, S., Fokin, M. (1978) Investigation of the Properties of a Carbon- and Chemical-Fiber-Based Material in Relation to Its Heat Treatment. Journal of Applied Chemistry of the U.S.S.R. Vol. 15, No. 6, Part 2:1287-1291.
8. Guniaev, G., Iartsev, V., Perov, B., Rumiantsev, A., Tiaukaev, V., Tumanov, A. (1976) High-Modulus Polymer Materials. *Fibrous Dispersion-Strengthened Composite Materials*, pp. 148-155.

9. Gulyayev, G., Perov, B. (1974) Some Properties of High-Modulus Epoxy Phenol Carboplast. *Plast. Massy.* No. 7:27-29.
10. Finogenov, G., Guniaev, G., Makmutov, I., Sorina, T., Stepanychev, E. (1978) Effect of Whiskerization of a Polymer Matrix on the Creep Resistance of Carbon Plastics Under Tensile Stress. *Strength of Materials.* Vol. 10, No. 9:1064-1068.
11. Guniaev, G. (1977) Increasing the Resistance of Unidirectional Carbon Fibers to Tension in a Transverse Direction, to Interlayer Shear, and to Compression. *Mekhanika Polimerov*, pp. 981-986.
12. Guniaev, G., Kobets, L. (1977) Resistance to Layer Shearing of Carbon-Fiber Plastics. *Mekhanika Polimerov*, pp. 445-451.
13. Tselikhovskiy, G. (1976) Interaction of Phenol-Formaldehyde Binders with Carbon Fibers. *Plast. Massy.* No. 11:64-66.
14. Gracheva, L., Podgorniy, A., Tretiachenko, G. (1979) The Deformation of Carbon Fiber-Reinforced Plastics of Different Densities under Heating to Elevated Temperatures. *Problemy Prochnosti.* pp. 46-50.
15. Bondarenko, N., Faikov, A., Mikhailov, V., Poliakova, N., Smirnov, B. (1976) Morphological Peculiarities of Carbon Fibers. *Mekhanika Polimerov*, Jan. - Feb: pp. 158-160.
16. Morozov, O., Radimov, N., Zhigon, I. (1979) Influence of Heat-Treating the Matrix on the Mechanical Properties of Carbon-Fiber Plastics. *Mekhanika Kompozitnykh Materialov.* pp. 925-929.
17. Guniaev, G. (1979) Influence of Carbon Fiber Surface Treatment on the Strength Characteristics of Carbon Fiber Reinforced Plastics. *Mekhanika Kompozitnykh Materialov.* pp. 603-606.

2.6 PROPERTIES OF MATERIALS

2.6.1 GENERAL PROPERTIES

The physical properties of a carbon fiber composite are determined by both the type of fiber used and the type of binder matrix resin system chosen. All carbon fibers used in structural materials have undergone some degree of graphitization, and the degree of graphitization is the primary determinant of tensile strength and modulus. The suitability of a particular fiber for a specific application is determined by the design requirements: cost, mechanical properties, and adaptability to an appropriate manufacturing process.

A number of matrix systems have been investigated for use with carbon fibers. The combination of fiber and matrix can result in an end product specifically tailored to meet the design criteria. There are many types of resins systems which have potential application to carbon fibers; in terms of incineration or other disposal of carbon fiber composites, the resin system used will be significant. While no resin systems presently available can survive temperature and oxidation conditions typical of incinerators, the rate at which the resins melt or oxidize will substantially influence the rate of release of free fibers, the quantity of fibers released, and the release location within the incinerator.

The pertinent properties of carbon fiber precursors, carbon fibers themselves, and various resin systems are discussed in this section, with particular emphasis on those characteristics which might affect incineration or disposal.

2.6.2 CARBON FIBER PRECURSORS

Carbon fibers are derived from three precursor materials: rayon, PAN (polyacrylonitrile), and pitch. Carbon fibers from rayon precursors are used primarily for heat shields, aircraft brakes and similar applications. In terms of carbon fiber materials likely to enter municipal waste streams, rayon-based fibers are not considered to be a major source at present.

PAN-based fibers account for the bulk of the carbon fibers now in use. Polyacrylonitrile is a well-established apparel fiber. American-made, textile grade PAN is used as the precursor for Great Lakes Carbon's Fortafil. Other PAN fibers, designed specifically for use as carbon fiber precursors, or high

quality textile fibers which meet the necessary requirements for carbon fiber production are used as precursors. The structural properties of the finished carbon fiber can be controlled by regulation of the process variables: temperature, tension, dwell time. In addition, the composition of the precursor can also have some effect on the final fiber properties. For example, until recently most carbon fibers have had a sodium content of approximately 0.1 percent. Ongoing developments aimed at reducing the sodium content of the precursor in order to increase the strength characteristics of the carbon fiber have resulted in the introduction of stronger fibers. However, no low sodium fibers have been used in the fire-release testing. In terms of incineration, it is probable that the low sodium fibers will oxidize more slowly than those previously tested.

Pitch-based carbon fibers are limited in use at present. Because the use of pitch precursors offers the potential for a substantial reduction in cost, this technology is being actively developed. Pitch-based fibers are generally not quite as strong as PAN-based fibers, but they have a higher tensile modulus (modulus of elasticity). Therefore, they are used in applications requiring great rigidity, such as space antennas. No pitch-based fibers were used in the fire release testing. There is no evidence to indicate that their oxidation or release characteristics would be materially different from those of PAN-derived fibers.

2.6.3 STRUCTURAL PROPERTIES OF CARBON FIBERS

Carbon fibers combine low density with high tensile strength and tensile modulus (modulus of elasticity). Typical densities are from 1.7 to 2.0 grams per cubic centimeter. For fibers other than mat material, tensile strengths range from 1.86 to 3.10 Gigapascals (270,000 - 450,000 psi). Tensile moduli range from 207 to 503 GPa ($30 - 73 \times 10^6$ psi). Table 2-8 compares the properties of a typical carbon fiber to structural aluminum and high-quality steel.

TABLE 2-8 COMPARISON OF CARBON FIBER, ALUMINUM AND STEEL

	Density (g/cc)	Tensile Strength (GPa)	Tensile Modulus (GPa)
Typical Carbon Fiber	1.8	2.53	312
Structural Aluminum	2.7	0.69	70
High-Quality Steel	7.7	2.07	200

Table 2-9 is a compilation by manufacturer, trade name and grade, of the properties of carbon fibers now being produced and used.

2.6.4 MATRIX RESIN SYSTEMS

A variety of matrix resin systems are available for use with carbon fibers. Resin systems may be divided into two classes: thermosetting and thermoplastic. Thermosetting resins are cured under temperature and/or pressure; once cured, they cannot be returned to their original state. Thermoplastic resins will flow under heat and/or pressure, conforming to the desired shape. Once formed, reapplication of heat and/or pressure can cause them to flow and reform.

Thermosetting resins have been used in applications requiring high strength in the finished part. In general, the thermosetting resins are used to bind together the carbon fibers, and the percentage of the composite consisting of carbon fibers is typically above seventy percent. At present, the objective in combining carbon fibers and thermoplastic resins has been to use the carbon fibers for reinforcing the plastic; typical percentages of carbon fiber in the finished composite are thirty to forty percent. Because thermoplastic resins have longer shelf lives, lend themselves to standard manufacturing processes, and can be used in high production rate applications, substantial effort is being expended on increasing the fiber content of the composite in order to approximate the strength characteristics available with thermosetting resin systems. Development of thermoplastic composites with upwards of seventy percent fiber content are underway for aerospace applications; as those techniques and materials are developed, they will find application in other areas.

TABLE 2-9. FIBER PROPERTIES AS MANUFACTURED

MANUFACTURER	MFG. LOCATION	TRADE NAME	GRADE	DENSITY		TENSILE STRENGTH		TENSILE MODULUS	
				g/cm ³	(lb/in ³)	GPa	(lb/in ²)	GPa	(10 ⁶ lb/in ²)
AVCO	Lowell, Mass.	Gravco		1.75	(0.063)	2.76	(400,000)	207	(30.0)
Celanese Plastics & Specialties Co.	Summit, N.J.	Celion	GY-70	1.97	(0.071)	1.86	(270,000)	503	(73.0)
	Rock Hill, S.C. (Proposed)								
Great Lakes Carbon Co.	Elizabethton, Tenn.	Fortafil	3	1.72	(0.062)	2.48	(360,000)	207	(30.0)
			5	1.77	(0.064)	2.76	(400,000)	331	(48.0)
Hercules	Magna, Utah	Magnamite	AS	1.80	(0.065)	3.10	(450,000)	234	(34.0)
			HTS	1.66	(0.060)	2.76	(400,000)	248	(36.0)
			HMS	1.83	(0.066)	2.21	(320,000)	365	(53.0)
HITCO	Compton, CA Gardena, CA	HI-TEX	1500	1.80	(0.065)	3.17	(460,000)	248	(36.0)
			3000	1.80	(0.065)	3.03	(440,000)	241	(35.0)
			6000	1.80	(0.065)	2.90	(420,000)	234	(34.0)
			12000	1.80	(0.065)	2.72	(395,000)	234	(34.0)
Stackpole Corp.	Lowell, Mass.	Panex	30	1.75	(0.063)	2.76	(400,000)	221	(32.0)
			30Y/800D	1.75	(0.063)	1.86	(270,000)	262	(38.0)
Union Carbide Corporation	Fostoria, Ohio	Thorne1	VMA (mat)	1.99	(0.072)	1.38	(200,000)	172	(25.0)
	Greenville, S.C.	Thorne1 50	WYR 30	1.80	(0.065)	2.43	(350,000)	393	(57.0)
			WYR 15	1.80	(0.065)	2.21	(320,000)	393	(57.0)
	Greenville, S.C. (Under construction)	Thorne1 300	WYP 90	1.75	(0.063)	2.92	(423,000)	236	(34.2)
			WYP 30	1.75	(0.063)	2.81	(408,000)	229	(33.2)
			WYP 15	1.72	(0.062)	2.69	(390,000)	229	(33.2)
		Thorne1 P-55	VS-32	2.03	(0.073)	2.07	(300,000)	379	(55.0)
		Thorne1 P-75	VSC-32-S	2.00	(0.072)	2.07	(300,000)	500	(75.0)

In terms of presently used matrix systems, epoxies represent the most widely used of the thermosetting materials; carbon fiber-reinforced nylon injected molded composites are the most widely produced thermoplastic materials.

Table 2-10 is a list of the generic types of matrix resin materials presently being used or investigated. The pertinent data relative to incineration of these materials are the melting point and the oxygen index. Since an incinerator temperature can reach 1,000° C, virtually all resin systems will be exposed to temperatures above their melting points. At these temperatures, the resins will either oxidize or decompose.

The O_2 index shows the percent of oxygen in the atmosphere required to have the material sustain combustion. Normal atmospheres are 22 percent oxygen; therefore, most matrices will not continue to burn unless surrounded by other more combustible materials.

TABLE 2-10. PROPERTIES OF RESIN MATRIX MATERIALS

GENERIC TYPE	CHEMICAL COMPOSITION	MELTING POINT (°C)	O ₂ INDEX	NO. MFGS.
EPOXY	Copolymer of epichlorohydrin and 2, 2 bis (4 hydroxy phenyl-piperazine)	215	29-46	140
MELAMINE/UREA FORMALDEHYDE	Cross-linked amino resins	†	30-36	9
PHENOLIC	Copolymer of phenol and formaldehyde	300	28-40	14
POLYAMIDE/POLYIMIDE	Specific group of amide-imide resins	300 - 400	*	8
POLYESTER (unsaturated)	Copolymer of alkylene glycols and unsaturated acids	300	32-48	24
ABS	Acrylonitrile-butadienestyrene copolymer	80 - 125	19-29	18
FLUOROPLASTIC	Fluorinated hydrocarbon polymers (CIFE)	Increases with fluorine content	> 95	27
NYLON	Specific group of polyamide resins (nylon 6, 66, 610, 10, 11, 12)	197 -264	22-26	23
POLYACETAL	Polymer of single or double carbon aldehydes	165	16	8
POLYARYL OR POLYETHER SULFONE POLYCARBONATE	Modified polysulfone polymers	160 - 230	38	3
POLYESTER (PBT)	A linear polyester of carbonic acid	241	25-30	9
POLYETHYLENE	Copolymer of alkylene glycols and phthalic acid	224	23-33	10
POLYPHENYLENE SULFIDE	Polymerized ethylene	135 - 141	26	32
POLYPROPYLENE	Thiophenolic polymer	285	46-53	4
POLYSTYRENE	Polymerized propylene	141 - 171	18-28	24
POLYSULFONE	Aromatic substituted linear polymer	†	18-28	23
POLYSULFONE	Aromatic sulfonic acid polymer	200	32	5
SAN	Styrene-acrylonitrile polymer	†	19-28	8

† - Variable within generic type

* - High temperature distortion, > 260° C; high thermal stability, > 370° C.

The Literature Search identifies over one hundred forty facilities and/or organizations throughout the United States which are presently engaged in the production of carbon fibers, prepregging of materials, or end product manufacturing or use of carbon fiber composite items. In terms of numbers, sporting goods manufacturers and aerospace firms are heavily represented in the end product manufacturing group. End product manufacturers indicating an expectation of using carbon fiber composites in their product lines in the near future were included in the listing.

Figure 2-10 indicates the geographical distribution of both primary carbon fiber production facilities and secondary manufacturers (end product manufacturers and prepreggers). Seven major manufacturers of carbon or graphite fibers are currently operating production facilities in nine locations as listed in Table 2-9. Union Carbide operates plants in Fostoria, Ohio and Greenville, South Carolina; in addition, a plant for the production of pitch-derived fibers is presently under construction in Greenville. HITCO operates plants in Compton and Gardena, California. The Gardena facility produces materials for use in aircraft brakes, heat shields and similar applications using carbon/carbon composites. HITCO's Compton plant produces HITEX fibers for use in structural composites. The Celanese Plastics & Specialities Company has recently announced that it will build a one million pound per year production plant in Rock Hill, South Carolina. The plant is scheduled to come on line in 1982, and will use a PAN precursor supplied by Toho Beslon (Japan).

The number of secondary manufacturers of carbon fiber products is also indicated on Figure 2-10. The Literature Search identified a total of one hundred thirty-eight secondary manufacturing facilities, which includes both end product manufacturers and prepreggers; the names and locations of these manufacturers are listed in Table 2-11. The function of prepregging was not clearly separable from other operations. Some parts manufacturers buy material which has been prepregged by the carbon fiber supplier. In other instances, the end product manufacturer buys carbon fiber from the manufacturer and uses his own or a purchased resin. Only occasionally, the flow of materials is from carbon fiber manufacturer to prepregger to finished part manufacturer.

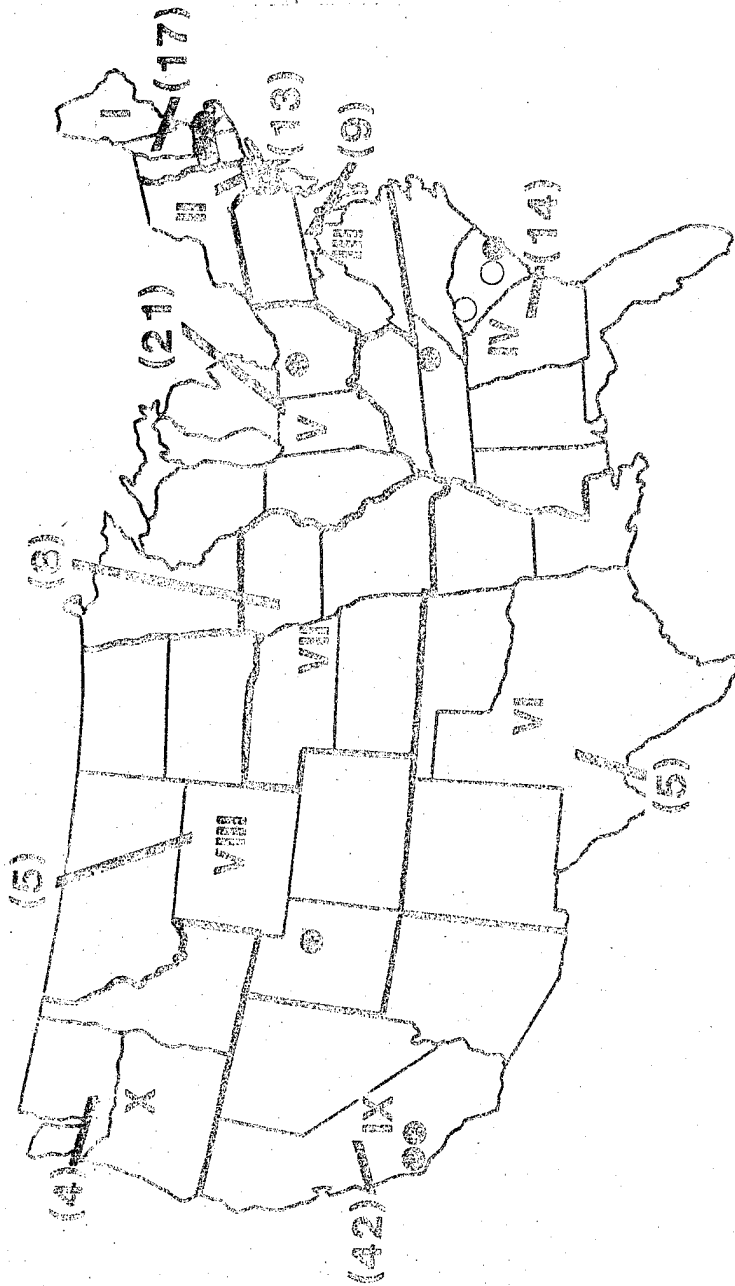

● - Fiber Production Plants (O proposed)

() - Number of Secondary Manufacturers

Figure 2-10. The Carbon Fiber Industry by EPA Region.

Secondary manufacturers are most heavily concentrated in the regions with a strong aerospace industry (Region 9) or the traditional heavy manufacturing regions (Regions 5, 2, and 1). Sporting goods manufacturers are distributed throughout the country, with appropriate regional variations (e.g., water skis in Florida).

TABLE 2-11 SECONDARY CARBON FIBER COMPOSITE
MANUFACTURERS BY EPA REGION

REGION I	REGION II
<p><u>MAINE</u> Fiber Materials, Inc., Biddeford Simplex Corp., Van Buren</p> <p><u>VERMONT</u> Oak-Fothergill, Inc., Bennington Orvis Co., Manchester Research Engineering Corp., Stowe</p> <p><u>MASSACHUSETTS</u> A & M Engineered Composites, Corp., Marlboro AVCO Corp., Lowell Perstorp-Ferguson, Florence Spalding Division of Questor, Chicopee</p> <p><u>RHODE ISLAND</u> Bancroft Sporting Goods, Woonsocket</p> <p><u>CONNECTICUT</u> Kaman Aerospace Corp., Bloomfield Olin Ski Co., Middleton U.S. Polymeric, Stamford United Technologies Research Center, Hartford Pratt & Whitney Sikorsky Aircraft Hamilton Standard</p>	<p><u>NEW YORK</u> AMF, Inc., White Plains Bell Helicopter, Division of Textron, Buffalo Carborundum, Niagara Falls CIBA-GEIGY Corp., Ardsley Grumman Aerospace, Bethpage Union Carbide, New York U.S. Industrial Chemicals, New York</p> <p><u>NEW JERSEY</u> Allied Chemical, Morristown Alpha Associates, Wood Bridge Chemplast, Inc., Wayne Garcia-Simplex, Moonachi Prince Manufacturing, Lawrenceville Rilsan Corp., Glen Rock</p> <p><u>PENNSYLVANIA</u> Boeing-Vertol, Philadelphia Budd Co., Phoenixville LNP Corp., Malvern Prodesco, Inc., Perkaskie Slazenger's, Inc., Cornwells Heights Westinghouse Electric, Pittsburgh</p> <p><u>DELAWARE</u> E. I. DuPont, Wilmington Hercules, Inc., Wilmington ICI America, Inc., Wilmington</p>

TABLE 2-11 (CON'T) SECONDARY CARBON FIBER COMPOSITE
MANUFACTURERS BY EPA REGION

REGION IV

KENTUCKY
Hillerich and Bradsby Co., Louisville

TENNESSEE
AVCO Corp., Nashville

NORTH CAROLINA
Graftek Division of Exxon, Raleigh

SOUTH CAROLINA
Coastal Engineering Products, Inc.,
Varnville
Dunlop Sports, Greenville
Shakespeare/Columbia, Columbia

ALABAMA
Childre & Sons, Foley

GEORGIA
Babcock & Wilcox, Augusta
Lockheed-Georgia, Marietta

FLORIDA
Biscayne Rod Manufacturing, Miami
Cypress Garden Ski Co., Tampa
Graftek Leisure Products, Cocoa
Martin-Marietta Aerospace, Orlando
Webb Machine Design, Clearwater

REGION V

MINNESOTA
Bellanca Aircraft Engineering,
Alexandria
Fiberite Corp., Winona
Johnson Fishing, Inc., Mankato

WISCONSIN
The Harkin Yacht Fitting Co., Pewaukee

ILLINOIS
Amoco Chemicals Corp., Naperville
ARMO Composites, St. Charles
Fansteel/Composite, Chicago
Hills McCanna Co., Carpentersville
Tremont Research Co., Chicago
Wilson Sporting Goods Co., River Grove

INDIANA
American Athletic Equipment, Jefferson

MICHIGAN
Budd Co., Madison Heights
Darton, Inc., Flint
Lamiglas, Inc., Utica
Thermofil, Inc., Brighton

OHIO
Babcock & Wilcox, Alliance
Cleveland Pneumatic, Cleveland
General Electric, Evendale
Keyon Materials, Cleveland
Quality Fiberglass, Marshville
Starwyn Industries, Dayton

TABLE 2-11 (CON'T) SECONDARY CARBON FIBER COMPOSITE
MANUFACTURERS BY EPA REGION

REGION VI		REGION IX	
<u>TEXAS</u>	Bell Helicopter, Division of Textron, Fort Worth	<u>CALIFORNIA</u>	Aldila, Inc., San Diego
	General Dynamics, Fort Worth		B & W Golf, Fountain Valley
	Skyline Industries, Fort Worth		California Tackle Co., Carson
	Vought, Subsidiary of LTV, Dallas		Composite Development Corp., San Diego
			Composite Optics, Inc., San Diego
			Conolon Corp., Santa Ana
<u>IOWA</u>			Convair Division of General Dynamics, San Diego
	Berkley & Company, Spirit Lake		Dexter Corp., Hysol Div., Pittsburg
<u>MISSOURI</u>			Diawa Corp., Gardena
	Hoyt Archery Co., Bridgeton		Ektelon, Inc., San Diego
	McDonnell-Douglas, St. Louis		Fenwick Products, Westminster
	Monsanto Corp., St. Louis		Ferro Corp., Culver City
<u>KANSAS</u>			Fiber-Resin Corp., Burbank
	Beech Aircraft, Wichita		Ford Aerospace & Communications Corp., Palo Alto
	Boeing Commercial Airplane, Wichita		Gordon Plastics, Inc., Vista
	Cessna, Wichita		Grafalloy Corp., Chalon
	Lake King Rod Co., Topeka		Graphite Master, Inc., Los Angeles
			Graphite Technology Co., Santa Ana
			Hexcel, Dublin
<u>UTAH</u>			Hughes Aircraft, Culver City
	Browning Mfg., Morgan		J. Kennedy Fisher, Inc., Los Angeles
	Hercules, Inc., Clearfield		Jennings Compound Bow, Valencia
<u>COLORADO</u>			Leach Industries, San Diego
	Head Ski/Wing Archery, Boulder		Lockheed Aircraft, Burbank
	Wright & McGill Co., Denver		Lockheed Space and Missile Systems, Sunnyvale
<u>NORTH DAKOTA</u>			Lynx Precision Golf Equipment, Paramount
	Grovel-Kelco, Inc., Minneapolis		Rohr Aircraft, Chula Vista
			McDonnell-Douglas, Long Beach
			Merlin Technologies, Inc., San Jose

TABLE 2-11 (CON'T) SECONDARY CARBON FIBER COMPOSITE
MANUFACTURERS BY EPA REGION

REGION IX (Con't)	REGION X
<u>CALIFORNIA (Con't.)</u>	<u>WASHINGTON</u>
Narmco Materials, Costa Mesa NHS, Inc., Santa Cruz Northrop Corp., Los Angeles Replex Industries, Buena Park Rockwell International, Downey Scepter Industries (Graphite Sales, Inc.), Chatsworth Textile Products, Inc., Stanton TRW, Redondo Beach U.S. Polymeric, Santa Ana Woven Structures, Inc., Compton	Boeing Aerospace Corp., Seattle Boeing Commercial Airplane Co., Kent Terry Ski Co., Issaquah <u>OREGON</u> Western Water Skis, Lake Oswego
<u>NEVADA</u>	
Dura Fiber, Inc., Carson City Lear-Avia, Reno	
<u>ARIZONA</u>	
Karsten Mfg. Corp., Ping Golf Club Div., Phoenix	

3.0 RISK ASSESSMENTS

3.1 OVERVIEW OF RISKS

The National Response to the carbon fiber problem identified three areas of concern in terms of risk assessments; these areas encompassed all the elements contained in the dictionary definition of risk as: "The possibility of loss or injury; peril". The three areas identified and investigated were: risk in terms of economic impact; possibility of injury to people; and peril to the national security. Six Federal organizations were assigned specific responses. The NASA, the Department of Transportation and the Department of Energy addressed the carbon fiber risk assessment as the possibility of loss in terms of economic impact. The Department of Labor (OSHA) and the Department of Health and Human Services (NIOSH Public Health Service) investigated the potential of injury to people arising from the fabrication and use of carbon fiber-based materials and products. Finally, the Department of Defense explored the potential risk to the national security which might arise from the effects of carbon fibers on the availability or utility of equipment vital to the defense of the nation. All six agencies looked at the risk from carbon fibers in terms of an increment to existing problems or conditions.

The importance of the timely development of the risk assessment is evidenced by recent history, in this instance in terms of the NASA assignment of responsibility regarding civil aircraft. Two near-maximum-possible incidents of crash-and-burn accidents (the two Boeing 747's at Tenerife and the DC-10 lost engine at Chicago) involved types of aircraft which may use structural elements incorporating carbon fiber-based composites. While none of the three aircraft actually involved in the incidents made use of carbon fiber-based composites, some current models do. In terms of the risk assessment associated with incidents of this type, the risk attributable to the presence of carbon fibers would not take into account the damage and loss of life from the crash itself, but only that increment of damage resulting from the fall-out of carbon fibers carried aloft by the fire.

Since the most immediate projected uses for carbon fiber-based materials are in aircraft and transportation equipment, the risk assessment programs undertaken by the NASA and

the DOT addressed the economic impact of fire-release incidents involving aircraft and transportation equipment. The fire-release of carbon fibers into the air from such incidents could impact upon the generation, transmission and use of electrical power; hence, the involvement of the DOE in assessing the risk to electrical equipment from such releases and the Department's potential to be involved as an injured party in such incidents.

The NIOSH and the OSHA addressed the possibility for injury to people. The assignment to the NIOSH was to conduct a three year study to elucidate the specific mechanism of damage by fibrous materials. From such data, the OSHA will promulgate the regulations necessary for the protection of industrial workers handling carbon fibers. The scope of the effort covered all sources of airborne carbon fibers and was not limited to those released from a crash-and-burn incident. The efforts focused on those fibers considered capable of reaching the alveoli within the lungs. Such fibers have diameters less than 3.5 micrometers, and length-to-diameter ratios in the range of 3:1 to 10:1. The discovery of a long-term health hazard from asbestos fibers attributes a health hazard to all respirable fibrous aerosols. Current experimental programs utilize laboratory animals to measure morbidity and mortality effects from exposures to concentrations of fibrous aerosols. These experimentally derived probabilities for injury become the bases for regulatory limits established for humans. Risk Assessments are elements in the ordered process of establishing the limits for exposures and the promulgation of regulations. For these agencies then, risk becomes an assessment of the probability for human reaction to a given level of exposure, that level of exposure being defined as a result of tests which involve laboratory animals.

The Risk Assessment developed by the DOD was conducted from the point of view of a user of materials with a concern that fall-out could impact either on the operation or the availability of equipment vital to the defense posture of the nation. As with the assessments conducted by the NASA, the DOT and the DOE, the study conducted by the DOD addressed the possibility of airborne carbon fibers causing failures in electrical or electronic circuits. The critical parameter of these four assessments related to the populations of single, airborne fibers of lengths sufficient to bridge the spacings between elements of electrical circuits (i.e., fibers longer than one millimeter).

3.2 SUMMARY OF RISK ASSESEMENT PROGRAMS

The descriptions of the six risk assessment programs have been compiled in a common format organized as follows:

- 3.X.1 - Sponsor and Title of the Program
- 3.X.2 - Program Leadership
- 3.X.3 - Program Description (Definition, Objectives, Approach, Results)
- 3.X.4 - Contributors and Roles
- 3.X.5 - Interagency Data Exchange
- 3.X.6 - Schedule
- 3.X.7 - Funding

The programs of the six Federal organizations have been arranged in terms of the type of risk: economic impact; health hazard; and peril to the national defense. The order of presentation of the risk assessments, by organization, is as follows:

- 3.3 - National Aeronautics and Space Administration (NASA)
- 3.4 - Department of Transportation (DOT)
- 3.5 - Department of Energy (DOE)
- 3.6 - Department of Labor (OSHA)
- 3.7 - Department of Health and Human Services (NIOSH, Public Health Service)
- 3.8 - Department of Defense (DOE)

3.3 RISK ASSESSMENT PROGRAM, NASA

3.3.1 SPONSOR AND TITLE

Sponsor: NASA, Langley Research Center

Title: Graphite Fiber Risk Assessment Program
(GFRAPO)

3.3.2 PROGRAM LEADERSHIP

Mr. Robert Huston
Program Manager

Telephone: FTS 928-2851
(804) 827-2851

Address: Langley Research Center
Mail Stop 231
Hampton, Virginia 23665

3.3.3 DESCRIPTION OF THE RISK ASSESSMENT PROGRAM

3.3.3.1 RISK AS DEFINED BY THE AGENCY

For the NASA LaRC study, risk was assessed in terms of potential nationwide economic impact. The Risk Assessment assigned to the NASA LaRC concerned the effects of a crash-and-burn accident within the United States, involving those American-built civil aircraft employing graphite fiber-based composites as elements of structure. In such accidents, fire may consume the plastic binder within a portion of the composite and thereby release a quantity of electrically conductive graphite fibers into the air. These dispersing airborne fibers may enter buildings where, falling into items of electrical equipment, they could cause failures as malfunctions, arcs or sustained shorts. In this limited context, the assessment of risk is in the form of an estimate of the yearly increment of economic loss to the nation which can be attributed to such a fire release incident. For any year, the risk projection is the profile or characteristic in which the values for potential economic losses are displayed in terms of the probability for sustaining such a loss.

3.3.3.2 PROGRAM OBJECTIVE

The results of the risk assessment will become a factor in the national decision for defining the degree of utilization of graphite fiber-based structure within civilian aircraft. Therefore, the NASA LaRC Risk Assessment must provide the most accurate definition of the potential economic impact which can be extracted from presently available data and projections for use. The Risk Assessment employs the following types and sources of data to calculate an economic impact for years considered to represent the beginning of general usage (1985) and a maturity of such usage (1993) of graphite fiber-based composites in civil aircraft:

- Accident rates and damage - from NTSB records.
- Transport fleet size, mix and planned usage of graphite fiber - from aircraft manufacturers.
- Fiber releases from fires, dispersion fallout, entry into buildings and electrical failures - from test data.
- Economic impact - from business data, census data and on-site surveys of operating facilities.

The risk assessment draws data from all pertinent established sources to make cross-checks and verifications of projections. These sources include information concerning items such as weather patterns, plume dispersions, demographic data and economic data.

3.3.3.3 APPROACH AND CONTENT OF THE PROGRAM

The risk assessment required a systematic approach to each of seven major elements of the effort, as listed below. In each area, the project office defined the needed data and then proceeded to plan and implement an activity toward obtaining data of the needed accuracy. The actions took the form of special analyses, focused testing, special purpose surveys and development of analytic techniques:

1. Source

Potential sources of graphite fibers for involvement in a crash-and-burn accident were extracted from projections of future models, estimates of sales and plans for utilization of graphite fibers in advanced aircraft. The effort included direct participation by the manufacturers of transport aircraft

as well as surveys and comparison studies on which to base projections of graphite fiber usage in general aviation and helicopters.

2. Condition for Release

The conditions describing the potential release of graphite fibers into the air involve two sources. Analyses of previous crash-and-burn incidents were utilized to determine the damage to those portions of the aircraft which are likely to incorporate graphite fiber materials. Estimates for the amount of fiber released and for the length distribution of the released fibers drew from the results of a series of pool fire and fiber release simulation tests.

3. Dissemination, Fallout and Entry into Buildings

The dissemination and fallout of airborne particles have received both theoretical and experimental verification for a range of input conditions. An EPA dissemination model was adapted to describe the conditions for the dissemination of fire released fibers which takes into account the fiber fall rate. The predictions for entry into buildings involved an experimentally-based adaptation of an existing model for the entry of airborne aerosols. The finalization of the model involved a series of experimental measurements to quantify the passage of fibers through air filter media and a determination of the effects of turbulence on the settling of fibers within an enclosure.

4. Interaction with Electrical Equipment

The data which describes the interactions with electrical equipment represent the results of a systematic experimental program to identify and measure the effects of fiber in inducing failures. The principle areas of concern investigated were interactions with: household appliances; aircraft avionics; airport ground equipment; commercial items; and industrial equipment. The testing program was developed and conducted in a manner that permitted the results of one series of tests to be applied to analyses of other types of equipment. Thus, the test program could be scoped to an overall effort compatible with the capacity of the facilities available for the conduct of such testing.

5. Economic Impact

The United States generates a large quantity of pertinent economic data through the Bureau of the Census and the Chamber of Commerce. These data describe the content of communities in terms of dwellings, business employment and gross

product. The economic modeling utilized a series of on-site surveys to translate available data into economic predictions of the effects of a graphite fiber release within a community. These on-site surveys covered a representative cross-section of the United States and focused upon those areas which showed a potential for a significant impact if disrupted by a failure caused by airborne graphite fibers (e.g., hospitals, air traffic controls, emergency communications, central computers, continuous operation industries, etc.).

6. Development of Methods for Risk Calculation

The development of methods for calculating the risk resulted in the generation of specialized computer algorithms for performing the statistically-based calculations. To provide confidence in the results, the methods for calculating a National Risk Profile involved the generating of three independent algorithms, each using the same general concept and the same input data. The algorithms included the following features:

- a. Each algorithm relied on a scenario which repetitively simulated accidents at a representative number of major and minor airports throughout the United States. The National Risk Profile consisted of a statistical combination of individual airport risk profiles, each individual risk profile representing the compilation of a large (≈ 1000) number of accident scenarios for each airport evaluated.
- b. Each accident involved statistically balanced random draws for accident conditions in terms of aircraft, amount of carbon fiber involved, phase of operation, time of day, and weather conditions. These input data were all based upon the same descriptions of accidents, the same utilization of graphite fibers in aircraft, and the same degree of fiber involvement.
- c. Each algorithm utilized variations of the same model for the airborne dissemination of fibers. The dissemination models represented an adaptation of the existing established (EPA, AEC) prediction models for the movement of aerosols.
- d. Each algorithm utilized the same sources of demographic data (populations, number of households, business, industry, etc.). Within the algorithms, the calculations of economic

impact accommodate the experimentally defined data for fiber entry (transfer function) characteristics as well as the potential for interaction with electrical equipment (vulnerability).

The principal differences among the algorithms related to the modeling of economic impact and selection of a statistical approach. However, the algorithms provided results which were consistent with one another.

7. Development of Techniques for Measurement, Test and Analysis

The development of techniques addressed the problems associated with generating valid experimental data to support the risk calculation. These developments focused upon three major areas:

- a. Instrumentation and measurement systems. Obtaining valid test data required instrumentation which could accurately and repeatedly detect and measure the properties of airborne carbon fibers. This effort resulted in the development of a number of sensor systems in addition to the refinement of previously established counting and measuring techniques.
- b. Techniques for Testing. These efforts required the development and manufacture of equipment for the controlled dissemination of fibers into a chamber and the establishment of a fire release test facility.
- c. Analyses. The analytical efforts paralleled testing and addressed the dynamics of carbon fibers in closed rooms and closed containers, and the mechanics of entry of fibers into closed areas. In addition, these investigations also focused on the calculation or prediction of economic impact from the effects of fiber-induced failures in commercial or industrial locations.

3.3.3.4 RESULTS: PRINCIPAL MILESTONES

The Graphite Fiber Risk Assessment Program employed a phased approach. The principal milestones thus became:

Phase I. Preliminary Risk Calculation. Complete January 1, 1979. (Presentation October 31-November 1, 1979, NASA CP 2074)

This one-year effort saw the development of algorithms, instrumentation, test techniques, data and analysis to the point of producing a preliminary assessment of the National Risk Profile.

Phase II. Final Risk Calculation. Complete
January 1, 1980. (Presentation December 4-5, 1979, NASA CP 2119)

This effort represents a refinement of input data resulting from the use of better projections, test results, and a broader base of actual values. This resulted in the generation of the most realistic values for the National Risk Profile attainable with present capabilities.

Final Report

Target: Draft complete, April 1, 1980.
(Publication as a NASA SP)

This report will present the finalized risk calculation and the pertinent supporting data necessary to validate the effort.

3.3.4 CONTRIBUTORS AND ROLES

The GFRAPO itself provides the management and technical leadership for the entire program and oversees the conduct of all efforts provided through supporting organizations and agencies. In addition, the Project Office has assumed the role of technical leadership and direction in the conduct of the major pool fire and fiber release simulation testing. The contributing Government agencies, universities and private industries and their roles are listed below.

3.3.4.1 CONTRIBUTIONS BY GOVERNMENT AGENCIES (FUNDING TRANSFERS)

A. Ames Research Laboratory, NASA

1. Conduct of Fire Release Simulation Testing in the Redwood Test Facility. These tests evaluated the impact of a falling weight on a burned section of graphite fiber composite as a contributing effect to the release of airborne fibers. The data from these tests provided data on fiber length distribution, as well as quantity released. The effort involved two phases of testing, both now completed and in report. (The Redwood Facility was operated through a contractor, Scientific Services, Inc.)

2. Aircraft Fire Technology. Tests at White Sands, New Mexico. These tests are aimed at understanding the thermodynamics and related phenomena associated with large aircraft fuel fires. The tests are also used to develop sensor instrumentation for capture and measurement of combustion products. The NASA-ARC portion of the effort is part of an ongoing assignment relative to aircraft fires and their effects.

B. Air Force Rome Air Development Center

The graphite fiber exposure test chamber was used to measure the vulnerability of some terminal boards and electrical connector configurations. This work has been completed and reported. The RADC has conducted a series of exposure tests under USAF direction. The data pertinent to the GFRAPO effort has been made available.

C. Air Force Cambridge Laboratories

Balloon Team Support to Pool Fire Testing at Dugway Proving Grounds. The effort consisted of providing the Barrage Balloon teams and technology necessary to lift the instrumentation net (dimensions 1,000 ft. by 1,000 ft.) used during the three major pool fires. Work is completed.

D. Army Ballistics Research Laboratory

Conduct of testing. The testing of household and commercial electric equipment utilized the BRL chambers. In addition, the Flow Test Facility provided the data on transfer functions through air filter media. The testing has been completed and data is in report.

E. Army Dugway Proving Grounds

1. Support to Pool Fire Testing. The NASA-sponsored pool fire tests employed the range facilities and utilized both range operation and test support personnel. Activities proceeded under the directions of a NASA-LaRC director.

2. Participation in a Fiber Counting Technology Evaluation Effort. The line-intercept technique developed at Dugway for counting fiber populations on adhesive sensors became one-third of a three part effort to evaluate the accuracy of counting techniques. The efforts consisted of three teams independently counting the same set of fiber population samples selected from the results of burn tests performed in the chamber at NSWC, Dahlgren, Virginia.

F. National Bureau of Standards

Evaluation of the sensitivity of electrical household appliances to failures caused by fibers. The activity involved a systematic study of the present and projected use of electrical household equipment in order to define those items which represent 85 percent of the dollar value in the national use. A representative sample of these items (washers, dryers, refrigerators, dishwashers, mixer, irons, etc.) was purchased and evaluated for potential failures using a fiber simulator (probe). These results led to recommendations for actual exposure testing, which the BRL chambers performed. The activity has been completed.

G. Navy, Surface Weapons Center, Dahlgren, Virginia

1. Fire Release Simulation Testing, Burn-Blast and Impact. This effort continued an ongoing effort within a chamber facility. The tests investigated the release of fibers under conditions of burn only, burn-plus-blast, and burn-plus-impact. The results provided data on release quantities, fiber length distributions, and diameter reduction from oxidation. Efforts are completed.
2. Fiber Counting Technology Evaluation. The NSWC participation included generation of the reference samples and counting by the NAVY-developed "Area Sampling" Technique. The work is completed.
3. Contained Fire Release Tests. The Shock Tube at NSWC was modified to provide a controlled fire release test facility. The test program successfully demonstrated that fire-released graphite fibers can cause failures in

electronic equipment, and that failures under fire-release conditions occur at the same exposure levels as measured within chamber tests. The effort is complete.

3.3.4.2 CONTRIBUTIONS BY GEORGE WASHINGTON UNIVERSITY

The University received a grant to provide an overview and evaluation of the definitions of risk and of the statistical methods employed. The overview of risk definition was intended to assure consideration of all potential factors. The evaluation efforts reviewed the statistical modeling employed within the program. The principal activities were testing of the data for consistency, ascertaining the suitability of the data for application to the models, and determining that appropriate modeling techniques were employed.

3.3.4.3 INDUSTRIAL PARTICIPANTS (RESEARCH AND DEVELOPMENT CONTRACTS)

A. A. D. Little Co.; Operation Research Co.

1. Calculation of the Risk Assessments. These participants generated the three independent computer algorithms utilized to calculate the National Risk. In addition, the activities included the extraction of input data from NTSB records, and from the results of aircraft studies, testing, and industrial and demographic surveys conducted by each organization.
2. Instrumentation Development for Fire Technology Tests (ADL only). The participation consisted of the development and operation during test of a specially configured fire plume sampler. The instrument was used in support of the NASA-ARC technology testing at White Sands, New Mexico.

B. AVCO Corporation - Everett, Massachusetts Laboratories

The AVCO Laboratories conducted a series of fire release tests on panel samples utilizing a specialized flow test facility. The tests evaluated the release of fibers by a combination of fire and impinging gas jets. The data obtained were principally release quantities as a function of applied conditions. The testing provided some measurement of length spectra and some assessment of oxidation effects on fiber diameters.

C. Boeing Commercial Airplane Company, McDonnell Douglas Corporation, Lockheed - Burbank Company

1. Carbon Fiber Involvement in Fire Release Accidents. The major manufacturers of transport aircraft provided data which defined the potential involvement of graphite fiber in accidents. The efforts involved three facets:
 - a. Estimate of the size and fleet mix of the future transport fleet.
 - b. Projection of utilization of graphite fiber in future aircraft.
 - c. Assessment of damage to graphite fiber-bearing components in crash-and-burn scenarios.

This last element required surveying damage reports from past accidents and projecting the degree of burn exposure of each structural element which may, in the future, contain carbon fibers. Each company surveyed its own records and made its own projections. A Lockheed representative assumed the responsibility for developing a standardized system of damage description compatible with the input requirements of the risk assessment algorithms.

2. Aircraft Vulnerability. Each company made assessments of potentially vulnerable equipment carried aboard its transport aircraft. These assessments supported the selection of airborne avionic items for vulnerability testing. In addition, Boeing and Douglas each made analyses of aircraft ventilation systems which defined the degree to which airborne graphite fibers could enter an airplane if it were at an airport when a crash-and-burn incident occurred.

D. The Bionetics Corporation

Bionetics performed a Pathfinder role. The activity represented an extension of technical contributions which had been supporting the LaRC preliminary evaluation of the risk levels. The efforts involved engineering and test contributions as follows:

1. Special Analyses. These engineering-related specialized tasks provided the GFRAPO with the detailed information needed as part of the decision-making or problem-solving process. The efforts included analyses of specific problems such as graphite fiber effects on landing aids, studies of electric arcs, studies of fiber dynamics, studies of specified economic impacts, etc.
2. Development of Techniques. The requirements for test data generated the need to develop sensors for measuring the properties of airborne carbon fibers and methods for establishing and controlling an environment of airborne graphite fibers. These efforts included choppers, dispensing systems, measurement systems and sensors which led to the LaRC filing for patents.
3. Conduct of Special Testing. The requirements of the risk analysis identified the need for tests with complex set-ups, and for the development of non-standard procedures. These tests were conducted in the LaRC chamber or under specially controlled circumstances. These efforts included tests on operating avionics; investigations of the dynamics of fibers; evaluation of arc phenomena; evaluation of potential shock hazards; measurement of transfer functions through aircraft water separators and filters; studies of fiber break up in flow passages, etc.

D. TRW, Inc., Redondo Beach, California

TRW had supported earlier testing and analysis effort for the DOD related to graphite fibers. This experience led to involvement in three activities:

1. Data Analysis and Evaluation of Results from Fire Release Testing. This effort involved a detailed analysis and investigation of graphite fiber releases from pool fire tests. These data provided estimates of release quantity, fallout footprint, and fiber length distributions, and evidence of diameter reduction from oxidation.

2. Support of Fire Release Testing. This effort involved the construction and installation of a large network collector, and the subsequent data analysis. The unit involved a net, 1,000 feet on a side with a mesh size of 50 feet, designed to deploy instrumentation in the plume from a pool fire. The net was lifted by barrage balloons. These tests are now complete.
3. Support to the Counting Technology Evaluation. TRW provided the third independent evaluation of counting techniques and used a "selected area" approach.

3.3.5 INTERAGENCY DATA EXCHANGES

3.3.5.1 DATA GENERATED BY NASA

The GFRAPD will provide the following data items of value to other agencies:

- A. Fire release characteristics of single fibers and clumps from pool fires and from controlled fires accompanied by agitation and/or explosions. These results will include release quantities, length spectra and condition of fibers.
- B. Usage projections of graphite fiber materials in civil aircraft.
- C. Dispersion models for airborne graphite fibers.
- D. Data which quantify entry into buildings in terms of flow conditions and the fiber arresting characteristics of air filter media.
- E. Designs for fiber sensor and measurement systems.
- F. Data with which to define the sensitivity of electrical equipment to failures in terms of exposure to fibers.
- G. Economic modeling data which shows the impact of fiber-induced failures.

These data are contained in a series of individual contractor reports, NASA conference proceedings, patent disclosures and final program reports.

3.3.5.2 DATA OF VALUE TO THE NASA

The ongoing efforts of the NASA can benefit from the following types of information:

- A. The results of instrumentation development, testing, application or use.
- B. Data and analysis relating to the use of incinerators for carbon fiber disposal.
- C. Data and reports resulting from aircraft or other incidents with the potential for the release of airborne carbon fibers.

3.3.6 SCHEDULE

Figure 3-1 shows the general schedule for accomplishment of the program and the relationship between Phase I and Phase II. The risk calculations may be considered as a continuous effort. At the completion of the initial calculations, the work incorporated the needed modifications and proceeded continuously toward the final results. The efforts during Phase II included all the surveys and their results and utilized improved inputs resulting from the refinement of fire-release transfer functions and vulnerability assessments. Testing proceeded continuously; the bulk of the household/industrial testing was performed in the BRL Facility. The fire-release testing included work at ARC, AVCO and NSWC. The outdoor tests were performed at Dugway Proving Grounds and White Sands.

3.3.7 FUNDING

The NASA-LaRC Risk Assessment effort represents a commitment of \$7.8 million for both Phase I and Phase II.

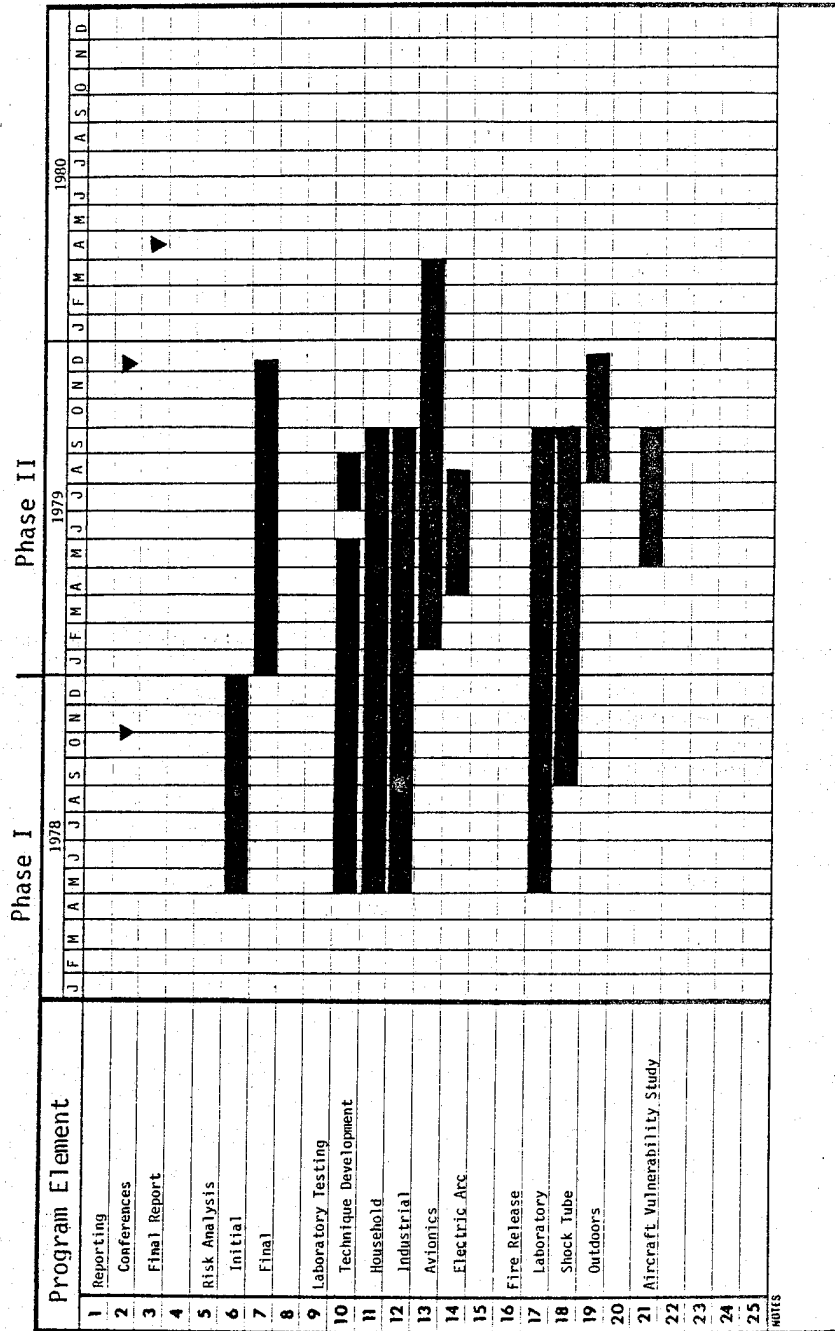

Figure 3-1. NASA Program Plan, Graphite Fiber Risk Assessment.

3.4 RISK ASSESSMENT PROGRAM. DEPARTMENT OF TRANSPORTATION

3.4.1 SPONSOR AND TITLE

Sponsor: Department of Transportation

Title: Carbon Fiber Studies Project Office

3.4.2 PROGRAM LEADERSHIP

Project Officer: William T. Hathaway

Technical Engineer: Dr. Karl Hergenrother

Telephone: FTS 837-2696 or 2273
(617) 494-2696 or 2273

Address: Transportation Systems Center
Kendall Square
Cambridge, MA 02142

3.4.3 DESCRIPTION OF THE RISK ASSESSMENT PROGRAM

3.4.3.1 RISK AS DEFINED BY THE AGENCY

The Department of Transportation defines risk in two contexts: the national economic impact of carbon fiber release incidents involving automobiles or trucks; and, the number of transportation equipment failures resulting from accidental release of airborne carbon fibers from any source.

Since one of the major future applications of carbon fibers is in the transportation sector, automobile or truck fires are considered likely sources of airborne carbon fibers. Release could result from fires which involve either the entire vehicle or those portions of the vehicle forward of the fire wall. The fire-released fibers have the potential for interacting with electrical equipment and causing failures. These failures may be temporary malfunctions, arcs, or sustained shorts. The yearly national economic impact is derived from the probability of occurrence and estimated cost of such failures, and is cast in present dollars. The forecast is for the year 1995, and takes two kilograms of carbon fibers per automobile or light truck and fifteen kilograms per heavy truck as a best estimate of usage at that time. Projections for the annual

number of transportation equipment failures for 1995 make use of the same figures.

3.4.3.2 PROGRAM OBJECTIVES

The DOT program addressed two major objectives:

1. Assessment of the vulnerability of transportation equipment to electrical failures caused by airborne carbon fibers.
2. Assessment of the national risk associated with the use of carbon fiber composites in surface transportation equipment.

The program to meet these objectives utilized data and analytical techniques developed for the NASA Risk Assessments to the extent possible. However, the types of binder resins likely to be used in the automotive and truck industry are different from those used in the aerospace industry. DOT separately investigated projected use and resin types in an effort paralleling the NASA-sponsored activity.

3.4.3.3 APPROACH AND CONTENT OF THE PROGRAM

The project was divided into the following tasks:

- A. Estimate the quantities of carbon fiber that will be used in the surface transportation system by 1995.

An estimate of the expected carbon fiber quantity and matrix composition in surface transportation was developed by DOT from a review of existing literature, the 1979 Department of Commerce survey, and several independent inquiries to carbon fiber suppliers and users. This effort established that the prospective use of carbon fibers in the transportation system would be in automobiles, light trucks and heavy trucks. The DOT estimates the yearly carbon fiber usage in surface transportation in 1995 at less than 5×10^7 kg. The estimate DOT chose for its risk assessment was 2 kg per car or light truck and 15 kg per heavy truck.

- B. Estimate the frequency and location of surface transportation system fire incidents.

The fire data input to the risk assessment consisted not only of an estimate of the frequency and geographic location of fires but also a

delineation of the fire-involved section of the vehicle. Fire frequency estimates were obtained from the U.S. Fire Administration (USFA) and the National Fire Protection Association (NFPA).

The Highway Safety Research Institute at the University of Michigan was the source of information establishing the relationships between annual automobile fires, location by county, and county population. This study indicated that cars in urban areas, where vehicle population density is highest, were most likely to be involved in fires.

Other aspects of the automobile fire scenario which are important to fiber release are fire severity and location of the fire on the vehicle. Fire location was important in determining which composite materials were exposed. Vehicle fires were classified as: engine fire, small; engine fire, severe; passenger compartment fire, small; passenger compartment fire, severe; and total conflagration. Severe fires were determined to be the only fires that will release carbon fibers. Since it is not anticipated that carbon fibers will be used in the passenger compartment, only severe engine fires and total vehicle conflagration fires will potentially result in fiber release. Roughly one-third of all car and truck fires fall into these categories. This estimate is based on an analysis of the passenger vehicle dollar loss statistics for fires and is published by the California State Fire Marshall.

- C. Estimate, through laboratory tests, the size and quantity of carbon fibers released by surface transportation fires.

Available laboratory and field test data for the fire-release of carbon fibers from composites were based on aerospace-grade, epoxy-based materials: testing usually included post-fire impact or explosion. This data was not considered an accurate representation of the fiber release to be expected from automotive-grade composite. Automotive composites are expected to be based on a matrix of vinyl-ester or polyester and glass fibers blended with carbon fibers.

DOT developed a series of laboratory tests to measure carbon fiber release from automotive-type composites. The tests were designed to evaluate

carbon fiber release under conditions which simulated automobile fires, i.e., high and low radiant heat flux with an 1800° C propane/air flame, fuel rich or fuel lean. Burning time was 10 minutes; there was no post-fire impact or explosion. Prior to the execution of the program by NASA-Ames and its contractor, Scientific Services, Inc., users and suppliers of the carbon fiber materials were asked to review and comment on the test program.

The quantity of carbon fiber released was found to be sensitive to test condition, but not to matrix resin. Depending on the test conditions, the results indicated an average carbon fiber release range from 0.003 to 0.06 percent of total composite carbon fiber weight. Ninety-nine percent of all carbon fibers released were less than three millimeters in length. Fibers of this length, in the quantities released, are unlikely to cause electrical failures in any individual incident.

- D. Estimate the vulnerability of the surface transportation system to airborne carbon fibers.

Surface transportation systems have been designed to operate reliably and safely in an environment of dust, oil, salt spray and vandalism. These system requirements produce a design which is not easily affected by carbon fibers. Analysis of fire locations indicated that most of the carbon fiber exposure would be in the vicinity of the urban roadway system. Since very little of this urban roadway system interfaces with the waterway transportation system, the vulnerability of water transportation was not evaluated beyond a brief qualitative determination that it would be relatively invulnerable to the few carbon fibers to which it would be exposed.

The method used to estimate the vulnerability of a surface transportation system was to divide the system into subsystems and, if necessary, components. The vulnerability of the subsystem or component could then be estimated from vulnerability data published by NASA and DOD. The effects are then categorized as safety, performance, or convenience failures. A safety failure occurs when there is a significant loss of system safety; a performance failure occurs when there is a significant loss in system performance; and a

convenience failure occurs when there is a significant loss in the perceived comfort or convenience of the passengers or crew.

This analysis led to the conclusion that automobiles, trucks and buses are effectively not vulnerable.

The electrified rail systems were subdivided into car-mounted, wayside, electrical substation, and signal subsystems. Analysis showed that, with the exception of the signal subsystem, failures were system performance malfunctions. Most failures were only momentary, and unlikely to require maintenance or repair.

- E. Estimate the national risk from carbon fibers released in surface transportation incidents.

A typical surface transportation release incident can be characterized as a release of 20 grams of single fibers, less than 3 mm long. Most of the fibers fall out within a kilometer of the source. Incident frequency is correlated with population. It is estimated that there will be 100,000 such incidents a year. Preliminary calculations show that the probability that there is any damage from an individual incident is very low.

The national risk due to fibers released by surface transportation was computed by the NASA Langley Research Center contractor Arthur D. Little, Inc. under a reimbursable agreement from DOT to NASA.

The result of their calculations was a projected annual national dollar loss, associated with the use of carbon fibers in surface transportation, on the order of \$6,000 per year.

3.4.3.4 RESULTS; PRINCIPAL MILESTONES

- A. Automotive type composite testing 5/78 - 12/78
- B. Calculation of risk assessment 1/78 - 10/79
- C. Vulnerability of surface transportation 6/78 - 9/79
- D. Final report--Draft 12/79--Projected Completion-4/80

3.4.4 CONTRIBUTORS AND ROLES

- A. Department of Commerce - market forecasts.
- B. Federal Emergency Management Agency (FEMA) - U.S. Fire Administration - estimated number of annual fires.
- C. California State Fire Marshall - dollar value assessment of fire damage.
- D. NASA/ARC, Scientific Services, Inc. - automotive type composite testing.
- E. Arthur D. Little - computation of risk assessment.
- F. University of Michigan - research statistics on surface transportation fires.
- G. Applications Research Corp. - computation of transportation vulnerability.

3.4.5 INTERAGENCY DATA EXCHANGES

3.4.5.1 DATA GENERATED BY THE DOT

The Department of Transportation studies resulted in the following types of information:

- A. Projections for carbon fiber use and type in automotive and truck manufacturing.
- B. Laboratory test results relating to the quantity and size distribution of carbon fibers released from vehicular fires.
- C. Vulnerability assessments of surface transportation equipment.

3.4.5.2 DATA OF VALUE TO THE DOT

In addition to the data which will be supplied to the DOT through the FAA, the following specific types of information are of interest to the Department:

- A. Data relating to the application of carbon fibers to transportation equipment.
- B. Results and analysis of potential carbon fiber release incidents involving transportation equipment.

C. Studies of the vulnerability of electrical equipment applicable to automobiles and trucks.

D. Information relating to carbon fiber related failures of surface transportation systems or equipment.

3.4.6 SCHEDULE

3.4.7 FUNDING

The DOT effort was funded at \$425,000. The investigation has been completed and the final report has been published.

3.5 RISK ASSESSMENT PROGRAM, DEPARTMENT OF ENERGY

3.5.1 SPONSOR AND TITLE

Sponsor: Department of Energy

Title: Study of the Effects of Accidentally
Released Carbon/Graphite Fibers on
Electrical Power Equipment

3.5.2 PROGRAM LEADERSHIP

Mr. Thomas Garrity
Chief, Power Delivery Branch

Telephone: FTS 633-9296
(202) 633-9296

Address: Division of Electric Energy Systems
Energy Research and Development
Administration
200 Massachusetts Avenue, NW
Washington, D.C. 20545

3.5.3 DESCRIPTION OF THE PROGRAM

3.5.3.1 RISK AS DEFINED BY THE AGENCY

The Department of Energy defines risk to an electrical power generation and distribution system as the probability for interruptions or unscheduled shutdowns resulting from effects not considered in the design of the system. The risk can then be translated into economic terms of lost revenue, cost of repair, and impact on service. The design of any power generation and distribution system strikes a balance between reliability and cost. The selection of insulators, specification of current breakers, and locations of components in the circuit must consider local conditions (lightning storms, presence of airborne contaminants, etc.) as well as electrical design parameters. A power generation and distribution system as installed will operate within a defined, acceptable limit of reliability, given specified environmental conditions. Any event which imposes environmental conditions more severe than the design criteria raises the threat of unanticipated failures. Risk becomes the probability for such failures; economic impact

relates to the recovery costs and inconvenience associated with such failures. Such unanticipated events do occur. For example, a once-per-century snowstorm hit northern Virginia in early October, 1979; the resulting broken-limb/downed-wire damage left the city of Warrenton, Virginia totally without power.

The presence of airborne carbon fibers adds an increment to the local environmental loading of other airborne conductive contaminants such as salt spray, cement dust, etc. The threat presented by airborne carbon fibers relates to the build-up of conductive material on the surface of an insulator sufficient to cause an arcing breakdown which damages either the conductors or the insulator. Risk becomes the probability for airborne carbon fibers to cause such a failure incident. The objective of the Department of Energy program is to quantify the risk to the electrical generation and distribution system associated with carbon fiber exposure. Two portions of the system were identified as areas of probable risk: high voltage transmission; and low voltage control of power plants and substations. The high voltage transmission insulation systems include: major high voltage external insulation in the four kilovolt to 765 kilovolt range; protected, but not sealed, insulating surfaces in switch-gear operating at 4,000 to 24,550 volts. Operating voltages of control circuits are generally 125-250 volts DC or 115-450 volts AC.

3.5.3.3 APPROACH AND CONTENT OF THE PROGRAM

The evaluation of high voltage transmission insulation vulnerability required DOE to implement a laboratory testing program performed by the Westinghouse Electric Company. Westinghouse developed a contamination test chamber which was used in conjunction with a high voltage power supply capable of producing representative distribution and transmission voltages from 5 kV to 34.5 kV. Celanese GY-70 fiber was selected for use in contamination testing because it had less tendency to form clumps and chopped easily, making it compatible with the experimentation procedures. Representative samples of distribution class insulation selected for testing included pin insulators, line posts, station posts, transformer bushings and suspension insulators. The results of this testing led to the definition of four parameters considered to be of value in determining flashover vulnerability of insulation exposed to carbon fibers:

- Fiber length.
- Fiber concentration.
- Insulation class (voltage).
- Airflow (wind).

Westinghouse is also developing a quantifiable slurry testing technique to supplant airborne fiber testing in a contamination chamber. Slurry testing is an accepted technique in the electrical insulation industry, and results in a reduction of total testing time for transmission class insulation. However, the correlation between the results of slurry tests and air tests with carbon fibers has not yet been fully established.

The vulnerability of power plant and substation control systems was the second of DOE's investigative responsibilities. Utilizing transfer function data generated by the NASA and integrating detailed design information on control systems obtained from Gibbs & Hill, Inc., DOE compiled an evaluation of vulnerability of the generic types of equipment within representative power generation and power distribution facilities.

3.5.3.4 RESULTS; PRINCIPAL MILESTONES

The DOE program identified a series of milestones and accomplishments during the course of the effort. These summarize as:

- A. Definition of the problem and approach to resolution. (Completed January, 1979.)
- B. Conduct of a test program to measure the effects of carbon fiber deposition on low voltage (<15 kV) insulation. These data will support the definition of a correlation with the existing contaminant simulation test techniques. (Completed in January, 1980.)
- C. Evaluation of high voltage insulation by a carbon fiber contaminant simulation technique. (Completed April, 1980.)
- D. Evaluation of power generation and power distribution equipment for susceptibility to airborne carbon fibers. (Completed December, 1979.)

3.5.4 CONTRIBUTORS AND ROLES

- A. NASA provided electronic test instrumentation; transfer function data; and results of vulnerability testing.
- B. Westinghouse Electric Corp. (Prime Contractor) studied the effects of accidentally released carbon/graphite fibers on electric power equipment. (DOE Contract No. ET-78-C-01-3171.)

- C. Gibbs & Hill, Inc. supplied design details of typical nuclear and coal-fired power plants and their respective equipment.

3.5.5 INTERAGENCY DATA EXCHANGES

3.4.5.1 DATA GENERATED BY THE DOE

The investigations conducted by the DOE provide data in the following areas:

- A. The effects of carbon fibers on high voltage (4-765 kV) insulation.
- B. The effects of carbon fibers on low voltage (115-450 volts) control circuits.
- C. Results of contamination chamber tests.
- D. Electrical characteristics of carbon fibers.

3.5.5.2 DATA OF VALUE TO THE DOE

The DOE interests relative to carbon fibers include the following:

- A. Data on the electrical characteristics of fibers.
- B. Information and reports on carbon fiber releases.

3.5.6 SCHEDULE

3.5.7 FUNDING

The \$400,000, 19-month contract with Westinghouse will be completed July 1, 1980.

3.6 RISK ASSESSMENT PROGRAM, U.S. DEPARTMENT OF LABOR

3.6.1 SPONSOR AND TITLE

Sponsor: The Occupational Safety and Health Agency
of the U.S. Department of Labor

Title: Health and Safety Standards for Airborne
Carbon Fibers

3.6.2 PROGRAM LEADERSHIP

Dr. R. Hays Bell
Coordination, Liaison

Telephone: FTS 523-7031
(202) 523-7031

Address: Department of Labor (OSHA)
Attn: Dr. R. Hays Bell
200 Constitution Avenue, N.W.
Room M-3651
Washington, D.C. 20210

3.6.3 DESCRIPTION OF THE RISK ASSESSMENT PROGRAM

3.6.3.1 RISK AS DEFINED BY THE AGENCY

The Occupational Safety and Health Agency within the U.S. Department of Labor defines risk in terms of the probability of injury or an impairment of health to individuals in the work place which results from a defined exposure to a specific agent. The OSHA operates by developing and enforcing standards in the areas of health and safety; risk assessments are part of the development process for new standards. The need for standards or regulation of an environment (e.g., establish the criteria for standards) generally arises from the results of studies and measurements conducted by the National Institute for Occupational Safety and Health. The development of a new standard begins with a risk assessment where the degree of accuracy in the supporting data is reflected as uncertainty in the risk projections. The OSHA standards are conservative, representing the maximum feasible protection for workers. Therefore, the steps involved in the development of a new standard become:

1. An assessment of the health and safety risks of the workplace.
2. An evaluation of the costs of alternate strategies for protection and control.
3. Selection of the most cost-effective method for complying with the standards, including the timing of implementation.

The development of an OSHA standard first considers the health impact, then the financial impact.

3.6.3.2 PROGRAM OBJECTIVES

In carrying out its legislated responsibility, the OSHA will develop and enforce any standards or control measures necessary for the protection of individuals working in an environment containing airborne carbon fibers. The airborne carbon fibers present in the workplace do not experience high temperature oxidizing environments and the concomitant diameter reduction; consequently, the sizes of the fibers remain in the range for nuisance dust and irritants. Until studies show a problem directly attributable to the carbon, the levels for exposure to carbon fibers will be included in any regulations on exposure to other fibrous materials.

3.6.3.3 APPROACH AND CONTENT OF THE PROGRAM

The carbon fiber related activity within the OSHA will consist of liaison and monitoring of data from studies related to the health effects from exposures to fibrous aerosols. No specific action relative to carbon fibers is planned until data exist which show a specific health hazard particular to airborne carbon fibers.

In the general area of respirable fibers, OSHA will base changes to standards and regulations upon levels recommended by the DHHS through the PHS. For respirable fibers, the current recommended concentration limit is 0.1×10^6 fiber/m³ average over an 8-hour period. This applies to fibers less than 3.5 micrometers in diameter and longer than 5 micrometers. This limit does not have any practical relationship to carbon fibers longer than 1 mm (electrical hazard). Airborne carbon fibers tend to form into clumps, the tendency increasing in proportion to the length of the fiber. Operating experiences with test chambers indicate concentrations of 1×10^5 fibers/m³ as the clumping limit for 1 mm fibers; for 10 mm fibers, the concentration limit drops into the range of $2 - 3 \times 10^4$ fibers/m³. Clumps have fall rates an order of magnitude larger than single fibers. An ordinary window screen provides more than an order of magnitude reduction in the population of clumps.

3.6.3.4 RESULTS: PRINCIPAL MILESTONES

The result of any OSHA action would be the development and promulgation of a standard for controlling the exposures to carbon fibers in the workplace. This action will occur at the time a specific need can be established.

3.6.4 CONTRIBUTORS AND ROLES

This effort will be performed within the OSHA.

3.6.5 INTERAGENCY DATA EXCHANGES

3.6.5.1 DATA GENERATED BY THE OSHA

The OSHA will operate in a monitoring and evaluation mode until a need can be defined for a specific action. At that time, participating agencies will receive drafts of proposed regulations and any appropriate explanatory data.

3.6.5.2 DATA OF VALUE TO THE OSHA

The following types of data would contribute to the development of a standard should the need arise:

1. Results from carbon fiber fire release and vulnerability testing.
2. Performance capabilities and measurement experience with carbon fiber sensing instruments.
3. Results of testing and investigations into carbon fiber emissions or releases.
4. Results and experiences with disposal techniques for carbon fiber-bearing materials.
5. Results from NIOSH studies.
6. Listing and location of the principal carbon fiber production and manufacturing operations.

3.6.6 SCHEDULE

3.6.7 FUNDING

The OSHA activities represent a continuing effort with no separate scheduling or funding.

3.7 RISK ASSESSMENT PROGRAM, DEPARTMENT OF HEALTH AND
HUMAN SERVICES

3.7.1 SPONSOR AND TITLE

Sponsor: U.S. Public Health Service (NIOSH)
Robert A. Taft Laboratories

Title: Evaluation of Health Aspects of Carbon
Fibers

3.7.2 PROGRAM LEADERSHIP

Mr. Ralph Zumwalde, Coordinator of Effort
Industrial Hygenist
Division of Surveillance, Hazard Evalu-
ations and Field Studies

Telephone: FTS 684-3255
(513) 684-3255

3.7.3 DESCRIPTION OF THE RISK ASSESSMENT PROGRAM

3.7.3.1 RISK AS DEFINED BY THE AGENCY

The U.S. Department of Health and Human Services defines risk as a probability of illness, disability, or death resulting from a definable exposure to a health damaging agent. A complete definition identifies any thresholds for the onset of the effect; expresses the number of incidents per thousand individuals (or in similar terms) as a function of the exposure level; and identifies the exposure level which results in an involvement of the total population. Hazards to health rarely permit such a complete definition; therefore, risks become projections from statistically-based mathematical models using data extrapolations from animal experiments or population studies. The risk models are made conservative. In general, the models do not recognize thresholds; risk only becomes zero for a zero exposure. The extrapolations which relate the number of cases to the level of exposure use the same forms of linear exponential expressions as were used to predict carbon fiber-induced failures in electronic equipment. For conservatism, the data selected for extrapolation employ the most sensitive condition measured. For example, when the extrapolation employs data from animal experiments, the results from

the most sensitive species or strain generally become the base. Extrapolation to humans would then ratio the exposure on a dose-per-pound basis. The approach to risk definition applies with varying degrees of uncertainty to all toxic, carcinogenic, pathogenic, or lethal agents. Carbon fiber composites have demonstrated compatibility with human tissue in their usage as medical implants. Carbon fibers, as manufactured, have diameters and lengths which preclude their passage through the air channels which lead to the alveoli of the lungs; these fibers may, however, act as a skin irritant in a manner similar to that associated with fiberglass. However, a portion of the carbon fibers released from fires show a reduction in diameters from the effects of oxidation. Some of these fibers have diameters and lengths which would permit their passage to the alveoli. This population of fire-released carbon fiber falls into the size category of fibrous aerosols associated with the carcinogenic effects attributed to asbestos. Since all other carbon fiber effects are either benign or at the worst an annoyance, oxidized fire-released carbon fibers become a sporadic increment to an essentially larger problem. The continuing efforts now under way to develop an understanding of the asbestos problem are considered to envelop any concerns presented by the fire-release of respirable carbon fibers.

3.7.3.2 PROGRAM OBJECTIVES

The U.S. Public Health Service strives for an understanding of causes and effects relative to a health damaging agent. The programs are research-oriented and generate the kinds of data which improve or focus prediction models. The efforts which relate to carbon fibers are contained within the investigation into fibrous aerosols and stem from the asbestos problem. The three broad objectives of the continuing program are:

- A. Definition of the manner in which fibrous aerosols actually cause the damage to the tissues in the lungs such that carcinogenic reactions occur.
- B. Definition of the extent of human involvement from exposure to fibrous aerosols.
- C. Identification of control measures which can reduce or eliminate human reactions to fibrous aerosols.

3.7.3.3 APPROACH AND CONTENT OF THE PROGRAM

Although no specific carbon/graphite fiber studies have been initiated, several ongoing research studies with other fibrous materials have been and are being looked at carefully to identify potential health implications. They are:

A. Fibrous Clay

A mortality study of workers exposed to fibrous clay (attapulgitite) is near completion. The typical median fiber sizes observed in airborne exposures were 0.07 μm diameter and 0.4 μm length. These fibers are more than an order of magnitude smaller than any which have been observed for carbon/graphite composite fibers; however, the results of the study should add significantly to the assessment of risk based on fiber size.

B. Fibrous Glass

1. A study of workers exposed to small diameter (<1.0 μm) fibrous glass is continuing for observation of any excess mortality. Latency from onset of exposure has been approximately 20 years, which is considered the minimal time required to observe any cancer.
2. A chronic inhalation study with fibrous glass has been initiated. Both rats and monkeys are being exposed to four different exposure parameters:
 - a. conc. 15 mg/m^3 - fibers 4-6 μm dia/
40-50 μm length
 - b. conc. 15 mg/m^3 - fibers 1 μm dia/
10 μm length
 - c. conc. 5 mg/m^3 - fibers 1 μm dia/
10 μm length
 - d. conc. 5 mg/m^3 - fibers 1 μm dia/
10 μm length

This is an 18-month study in which pulmonary function tests will be given at periodic time intervals and with animals sacrificed at the completion of the study for tumorigenic observation. At the 6 month point into the study no significant decrease in pulmonary function has been observed.

C. Asbestos

1. An industrial hygiene study has been completed on workers employed in the servicing of automobile and truck brakes. Exposures to asbestos have indicated concentrations below the NIOSH

recommended 8-hour Time Weighted Average (TWA) of 0.1 fibers/cm³ and with most of the fibers (>80%) smaller than 5 µm in length. A mortality/morbidity study has been initiated to study the health risks to workers associated with low level exposures to asbestos fibers.

2. A chronic inhalation study with chrysotile asbestos shorter than 5 µm length is currently underway. Both rats and monkeys are being exposed over an 18-month period to an asbestos concentration of 1.0 mg/m³, 7 hrs/day, 5 days/week. At the 6 month point into the study animal sacrifices have indicated asbestos fibers in the tissues but no indication of fibrosis.

3.7.3.4 RESULTS, PRINCIPAL MILESTONES

The results from all of the studies to date will support further analyses toward establishing specific cause and effect relationships. The studies of worker exposures represent elements in a continuing monitor and evaluation effort. The animal studies will be completed by December, 1980. The testing of animals exposed to asbestos involves periodic sacrificing such that incremental results do appear.

3.7.4 CONTRIBUTORS AND ROLES

The conduct of the studies utilized both the in-house capability of the NIOSH and support from commercial research laboratories.

- A. In-house studies: The three studies involving workers (clay, glass, asbestos) are efforts performed within NIOSH-directed laboratory groups.
- B. Support from commercial laboratories:
 1. The Battelle Laboratories, Columbus, Ohio, has been contracted to perform the inhalation study for fibrous glass involving rats and monkeys.
 2. The International Research Company, Matawan, Michigan, has been contracted to perform the inhalation study for short fiber chrysotile asbestos.

3.7.5 INTERAGENCY DATA EXCHANGES

3.7.5.1 DATA GENERATED BY THE PHS

The study and test program to determine cause, extent and central measures will generate a series of reports showing the status of and results from investigations. Unless specific results appear which show a particular sensitivity to carbon fibers, these reports will be directed to agencies working in the broad area of fibrous aerosols.

3.7.5.2 DATA OF VALUE TO THE PHS

The PHS has received both data and samples from the NASA-sponsored fire-release testing. The final fire-release tests at Dugway included NIOSH-supplied air samples for analysis by the PHS. These data exchanges will continue. The following types of data would offer supporting information toward conduct of surveys and development of testing techniques:

- A. Results from carbon fiber fire-release testing.
- B. Experience with handling carbon fibers in laboratory investigations.
- C. Performance capability of, and measuring experience with, carbon fiber-sensing instruments.
- D. Results and experiences with carbon fiber emissions or releases.
- E. Results and experiences with disposal techniques for carbon fiber composite materials.
- F. Listings and locations of the principal carbon fiber producers and manufacturing operations.

3.7.6 SCHEDULE

3.7.7 FUNDING

The PHS activities represent a continuing effort with separate scheduling or funding devoted to carbon fibers.

3.8 RISK ASSESSMENT PROGRAM, DEPARTMENT OF DEFENSE

3.8.1 SPONSOR AND TITLE

Sponsor: Department of Defense

Title: Studies of Carbon Fiber-Related Effects
Under the Program Title "Have Name"

3.8.2 PROGRAM LEADERSHIP

Lt/Col Lawrence Abramson
Former Chairman, JTCG
U.S. Army
Ballistics Research Laboratory

Mr. Raymond Polcha
Chairman, Joint Technical Coordinating
Group
U.S. Navy
Naval Surface Weapons Center

Telephone: (703) 663-8781

Address: Naval Surface Weapons Center
Code F-56
Dahlgren, Virginia 22448

3.8.3 DESCRIPTION OF THE RISK ASSESSMENT PROGRAM

3.8.3.1 RISK AS DEFINED BY THE AGENCY

The Department of Defense assessed the risk resulting from the release of carbon fibers in terms of the probability that such a release would incapacitate equipment or impair the capability of a military unit to perform an assigned mission. Carbon fibers represent a potential threat to the effectiveness of military units and the serviceability of military equipment, and may require the installation of appropriate defense measures to counter the threat. The risk assessment then is cast in terms of the probability of loss of capacity or capability resulting from an incident, in light of the defensive measures which have been installed. In addition to assessing the probability of loss of capacity or capability, the DOD was required to assess the probability of interruption or disablement of equipment

and/or unit effectiveness. In order to estimate the impact of loss, interruption or disablement, the duration of such effects had to be considered. Thus, the risk assessment takes into account both the probability of impairment or loss of capacity or capability and the duration of such impairment or loss.

Because of the potential for widespread application of carbon fiber-based materials to military aircraft, the Department of Defense must consider crash-and-burn incidents as a possible source of carbon fiber release. In many cases, however, the concerns of the DOD must extend beyond those associated with civil equipment. For example, when the F-18 Hornet Fighter becomes operational as a carrier-based aircraft, the carriers must have an installed capability to repair damage to structures of the aircraft, including those involving carbon fibers. The ship must be stocked with the materials for repair (tow, cloth, prepreg, resins) and have the facilities and equipment needed to cut, fit, lay-up, impregnate and polymerize the resin. Repair activities may take place on the hanger deck, possibly in adverse sea conditions; or while the ship is engaged in a hostile action. In addition to the possibility of a crash-and-burn incident on the flight deck, the Navy must consider the possibility of battle damage to the aircraft and those sections of the ship which store or process carbon fiber materials. Considerations similar to those outlined for the Navy must be made by the Air Force and Army relative to their specific modes of operation of carbon fiber-bearing equipment. Thus, the DOD faces threats and risks which extend beyond those identified for civil equipment, both in complexity and type. The DOD, therefore, is required to investigate the effects of carbon fiber releases, with specific emphasis on those unique requirements associated with military operations.

3.8.3.2 OBJECTIVES OF THE PROGRAM

The DOD conducted a program which had features which paralleled portions of the NASA Risk Assessment effort and thereby provided a degree of data exchange. The DOD efforts will continue in conjunction with the introduction of advanced aircraft and equipment. While such efforts are not considered part of the risk assessments, they will draw from the experience and data obtained from the risk programs. The DOD efforts identify three broad objectives:

1. Definition of the sources and characteristics for carbon fiber releases.
2. Definition of the vulnerability of military equipment when exposed to carbon fibers.

3. Definition and implementation of measures which protect from carbon fiber releases and control accidental releases.

3.8.3.3 CONTENT OF THE PROGRAM

The DOD program contained a series of interrelated activities. The JTCG provided the means for the necessary coordination and exchange of data. These efforts may be categorized by type of activity.

- A. Evaluations of sources and release characteristics. The DOD conducted a series of fire-release tests and analyzed the results. Analysis of crash-and-burn type incidents led to a series of outdoor burn tests, culminating in pool fire exposures conducted by the U.S. Navy Test Range at China Lake, California. These tests provided information relative to the action of fibers in plumes, and the type of fallout and distribution pattern of typical fire-release materials. These results indicated that fiber diameters are reduced by oxidation in fires. Another series of tests investigated the effects of ordnance detonations on material released from a fire. These data, analysed with respect to military operations, provided the bases for defining vulnerability criteria and the requirements for protective measures. Limited fire-release testing will continue in support of new developments in carbon fiber applications.
- B. Vulnerability Studies. The DOD program included carbon fiber exposure testing of equipment items ranging from aircraft avionics, through communication items, to ground support electronics. In addition, one facet of the testing evaluated the effect of exposure on high voltage equipment, power generation equipment and power transmission items. The test program attempted to include a cross section of military equipment broad enough to encompass any potential release involving Army, Navy or Air Force installations. The test results from power transmission items, as well as from some of the general purpose electronic items, had value to other program investigations. The bulk of the data related to specifically configured military items and, therefore, had no utilization outside the DOD. Exposure testing of specific items of military equipment will continue in support of new applications for carbon fiber.

- C. Protections and Controls. The protection and control efforts comprised studies leading to the determination of the characteristics of fiber entry; the development of instruments for sensing the presence of fibers; the generation of design criteria for the protection of electrical equipment against fibers; and the generation of a procedure for handling a crash-and-burn incident involving carbon fiber-based materials.

The studies of entry characteristics included both analysis and testing. The analytical effort modeled the transport of fibers through typical ventilation systems. The environmental testing effort served to verify the models by measuring the transport of a fiber simulant and by providing measurements of the transfer ratios through military-type filter media.

The development of instrumentation addressed detection of fibers. The early efforts led to the development of a charged grid type "sniffer" intended to support the cleanup operations of a crash-and-burn type accident. A limited number of these units are being evaluated in service. Provisions have been made to make them available in support of other agencies (e.g., FAA).

The results from vulnerability testing form the basis for generating a set of design guidelines or criteria aimed at minimizing the failure sensitivity of electrical items to carbon fiber exposure. The guidelines have been prepared in draft form and may become a reference requirement applied to the design of future electrical or electronic items intended for military application.

The utilization of carbon fiber-bearing composites in military aircraft and other flight equipment imposes the need for a well-defined general procedure for handling accidents. This procedure has been drafted, reviewed and implemented by those operations which utilize equipment carrying carbon fiber-bearing composites.

3.8.3.4 RESULTS; PRINCIPAL MILESTONES

The DOD-sponsored program represented an ongoing activity at the time of initiation of the NASA Risk Assessment efforts. The activities of the programs proceeded as companion projects, and pertinent data was exchanged. The principal outputs from the DOD program laid the foundation for the efforts

of the other agencies. The DOD outputs included:

- A. Data and Techniques From Fire-Release Testing. The NASA Risk Assessment utilized the techniques and instrumentation developed for pool fires in chamber testing as the point of departure for their efforts. The NASA relied upon DOD-developed counting technologies for working with adhesive sensors and commissioned further reduction of data from DOD pool fire tests.
- B. Test Chambers, Techniques and Instruments. The NASA Risk efforts utilized chamber, chopper, and fiber sensor designs and counting instrumentation developed by the DOD vulnerability studies. These designs provided the bases for more advanced concepts needed to work with the reduced diameters and shorter fiber lengths typically associated with fire-release testing.
- C. Vulnerability Studies of High Voltage and Power Transmission Equipment. The results from exposure testing and investigations of the effects of carbon fibers on high voltage and power transmission equipment served as the base for planning further vulnerability testing. These data supported the NASA efforts and contributed to the early definition of the DOE work.
- D. Modeling of Fiber Entry. The analytical models for fiber entry into buildings were adapted to the NASA algorithms. In addition, the DOD had developed a test facility and the techniques for testing filter elements, and provided the data for determining the transfer functions of air filter media used in civil and commercial applications.
- E. Accident Procedures. The USAF-developed procedure for handling accidents became an input element to the Federal Emergency Management Agency in its development of alerts and bulletins for municipal and airport fire departments.

The DOD is continuing to address application and operational considerations relative to carbon fibers, but not in the context of risk. However, the outputs of some of these ongoing programs are potentially of interest or benefit to other agencies. Three major areas of activity are identifiable from recent solicitations to industry. These areas are:

- A. Development of Resin Systems. The epoxy binders presently being used impose limitations in terms of moisture absorption, abrasion resistance, and compatibility with manufacturing procedures. The U.S. Air Force, Wright-Patterson Laboratories has solicited work toward improvement of resin systems in regards to the above parameters.
- B. Improvement of Quality Assurance. The U.S. Air Force, Wright-Patterson Laboratories is also supporting the development of quality assurance controls on materials, processes, and non-destructive test measurements which will result in improvement of the ability to assure the structural integrity of carbon fiber-based components.
- C. Repair Technology. Military operations demand an effective technology for repair of damaged parts. The U.S. Navy Air Development Center, Warminster, PA is sponsoring investigation of the structural integrity of the repaired items and the feasibility of accomplishing such repairs under field conditions.

3.8.4 CONTRIBUTORS AND ROLES

The DOD program involved all three services with effort at more than one facility for each service. The principle contributions are as follows.

3.8.4.1 CONTRIBUTIONS BY DOD

The DOD efforts were led by the Joint Technical Coordination Group with specific assignments in each branch of the service. Principal assignments included:

- A. JTCG, Present Chairman, Mr. Raymond Polcha, NSWC, Dahlgren. Former Chairman, Lt/Col L. Abramson, U.S. Army, Ballistics Research Laboratory. JTCG provided the coordinating focal point of the programs of the three branches of the Armed Services.
- B. U.S. Air Force Lead Organization, Rome Air Development Center, Griffis AFB, New York. RADC's continuing effort consists of vulnerability testing of electronics and development of a general purpose monitor sensor instrument.
- C. U.S. Army Ballistics Research Laboratories. BRL provided vulnerability test support and filter

media test measurement. Testing included evaluation of power transmission equipment. These activities are complete.

- D. U.S. Navy, Naval Surface Weapons Laboratory, Dahlgren, Virginia. NSWL conducted tests involving explosion- or fire-release of materials from carbon fiber-bearing composites. Continuing efforts will support materials development.
- E. U.S. Navy Bureau of Ships, David Taylor Model Facility, Maryland. DTM studied equipment vulnerability, particularly that of shipboard items.
- F. U.S. Navy Weapons Center, China Lake, California. NWC conducted fire-release testing.
- G. U.S. Air Force, Hanscomb AFB. (Former lead center.) USAF has responsibility for development of analytical modeling, test planning, and definition of requirements for the present sniffer.
- H. U.S. Army, Dugway Proving Ground. Dugway conducted outdoor testing involving dispersion of airborne materials, and vulnerability evaluations.

3.8.4.2 INDUSTRIAL PARTICIPANTS

- A. The Mitre Corporation, Boston, Massachusetts. Technical support to the U.S. Air Force. Assignments were in analyses and definition of sensing instruments. The sniffer is a Mitre-designed unit.
- B. TRW Incorporated, Redondo Beach, California. Technical support to the U.S. Air Force. Assignments involve conduct of pool fire testing and evaluation of fiber transport phenomena.
- C. A. D. Little Company, Boston, Massachusetts. Technical support to the U.S. Navy. Assignments involved analyses of vulnerability and modeling of fiber entry characteristics.
- D. Nuclear Systems Incorporated, Salt Lake City, Utah. Technical support to the U.S. Army. Assignments involved modeling of plumes, fallout, and dispersion patterns.

3.8.5 INTERAGENCY DATA EXCHANGES

3.8.5.1 DATA GENERATED BY THE DOD

The principal DOD-generated data of value to other agencies either supported the NASA Risk Assessments or was generated in conjunction with the Risk Assessment. These items are as follows:

- A. Results of vulnerability testing on electronic equipment. (U.S. Army, BRL.)
- B. Results of transfer function testing for air filter media. (U.S. Army, BRL.)
- C. Results of burn/explode testing for fiber releases. (U.S. Navy, NSWC, Dahlgren.)
- D. Procedure for handling crash-and-burn accidents involving carbon fiber materials. (U.S. Air Force.)

3.8.5.2 DATA OF VALUE TO THE DOD

The ongoing effort of the Department of Defense can benefit from the results of continuing activities of other agencies. Data of value to DOD include:

- A. Results of instrumentation and measurement technique developments. (EPA, Research Triangle Park, North Carolina)
- B. Results from incinerator tests involving carbon fiber materials. (EPA Cincinnati)
- C. Results and experience with fire-release accidents involving civil aircraft.

3.8.6 SCHEDULE

3.8.7 FUNDING

Future DOD efforts will be scheduled and funded as part of other programs.

4.0 CARBON FIBER RELATED PROGRAMS

4.1 OVERVIEW OF PROGRAMS

The National Response to the carbon fiber problem assigned specific responses to six Federal organizations (EPA, FEMA, FAA, DOS, NBS, DOC) and imposed a monitor-and-review requirement on an additional three (OMB, GAO, CIA). Implicit in the conduct of these efforts is an exchange of data among the agencies involved.

4.1.1 COMPLETED PROGRAMS

Two of the response organizations (DOS, NBS) have completed their assignments and will not generate further data. Specifically, the Department of State has issued the necessary advisories. The National Bureau of Standards assignment for investigation of the vulnerability of household appliances to carbon fibers has become a part of the NASA Risk Assessment Program.

The Department of Commerce surveyed nine carbon fiber producers, 27 prepreggers, and 55 manufacturers of sporting goods, under authority contained within the Defense Production Act of 1950. The results of this survey were combined with other data from industrial sources by DOC. The output of this effort was presented at the NASA-LaRC-sponsored final symposium for the Graphite Fiber Risk Assessment. The DOC results are presented in summary in Table 4-1. Current and projected U.S. supply of carbon fibers, as well as projected usage in four major categories (Aerospace, Automotive, Industrial, Sporting Goods), are presented. The figures shown are the results of the DOC compilation, tempered with data from other industrial sources, and, as such, should be treated as the best current estimates for import, export and projected use. These data are considered pertinent to the disposal technology effort of EPA-Municipal Environmental Research Laboratory (MERL). The DOC has completed its initial task assignments of developing and monitoring a carbon fiber industry data base. It will maintain the capability to continue or resume its monitoring and surveying activities should a need arise.

4.1.2 CONTINUING PROGRAMS

In addition to the EPA-MERL effort, there are three ongoing programs, in two categories: development of

TABLE 4-1. RESULTS FROM CARBON FIBER SURVEYS CONDUCTED BY
THE U.S. DEPARTMENT OF COMMERCE

	YEAR				
	1976	1977	1978	1979	
CURRENT MARKET ASSESSMENTS					
(All values in thousands of pounds)					
U.S. Production Capacity	841	860	933	1,041	
A. U.S. Production	316	397	478	625	
B. Imports Identified	143	192	291	440	
C. Exports Identified	(-) 14	(-) 16	(-) 39	(-) 59	
Net U.S. Supply	445	573	730	1,006	
PROJECTIONS FOR PRODUCTION AND USAGE					
(All values in thousands of pounds)					
U.S. Supply	1980	1983	1985	1990	1995
A. Production Capacity	970	4,500	11,300	27,000	59,000
B. Imports	690	1,400	490	600	1,000
C. Exports	(-) 100	(-) 760	(-) 250	(-) 500	(-) 1,000
Net U.S. Supply	1,560	5,140	11,540	27,100	59,000
U.S. Demand					
Aerospace	470	1,400	2,200	3,900	6,600
Automotive	25	100	200	25,000	40,000
Industrial	170	300	500	1,000	2,000
Sporting Goods	260	590	900	2,000	2,300
TOTAL	925	2,390	3,800	31,900	60,900

instrumentation and measurement techniques; and reporting and analysis of potential release incidents. The EPA-Environmental Sciences Research Laboratory (ESRL) at Research Triangle Park, North Carolina, is developing instrumentation and measuring techniques necessary to identify and quantify emissions of airborne carbon fibers. The instrumentation effort has focused on two applications. The first configuration will be applied to in-duct or stack monitoring; the second configuration will be for use as an ambient monitor. As far as practical, these units will represent modification or adaptation of existing sensing instruments and practices. The ESRL investigation of measuring techniques will result in two outputs. First, a definition of a reference standard technique for identifying and measuring carbon fiber emissions from stationary sources (factories and incinerators) will be developed. Second, techniques for measuring carbon fibers collected on membrane filters will be addressed. The EPA presently employs a large number of portable air samplers which make a dichotomous separation of airborne solids. These solids are collected on membrane filters. Therefore, a series of techniques which can specifically identify and measure carbon fibers collected during an air sampling sequence is needed. To the extent practical, these techniques should be consistent with the methods already established for other aerosols; thus, the development of techniques begins with procedures based upon microscopy and elemental analysis for carbon.

The two ongoing programs focusing on the reporting and analysis of potential release incidents are being conducted by the FAA and the FEMA. In carrying out its responsibility to monitor, report and analyze aircraft incidents which could lead to the release of carbon fibers, the FAA has integrated a carbon fiber designation into its existing system of aircraft identification by certification number ("tail number"). In the event of an accident report, the tail number listing is consulted, and those aircraft utilizing carbon fiber composites will be identified from a recognizable notation in the listing.

The FEMA (formerly Defense Civil Preparedness Agency) received the assignment to provide carbon fiber hazard-related data and instructions to local police, fire and emergency service units. In addition, FEMA undertook the structuring of a reporting system for identifying and analyzing civil incidents which could result in the release of airborne carbon fibers. The reporting system has been incorporated into the existing national monitor and reporting network for accidents, fires and natural disasters.

4.2 OUTLINE OF CONTINUING PROGRAMS

The description of the three continuing Federal programs have been compiled in a common format with the presentation organized as follows:

- 4.X.1 Agency and Title of the Program
- 4.X.2 Program Leadership
- 4.X.3 Program Description (Objectives, Contents, Outputs)
- 4.X.4 Contributors and Roles
- 4.X.5 Interagency Data Exchanges
- 4.X.6 Schedule
- 4.X.7 Funding

The three programs are presented in the following order:

- 4.3 EPA, Environmental Sciences Research Laboratory
- 4.4 Federal Aviation Administration
- 4.5 Federal Emergency Management Agency

4.3 PROGRAM FOR THE U.S. ENVIRONMENTAL PROTECTION AGENCY-
ENVIRONMENTAL SCIENCES RESEARCH LABORATORY

4.3.1 SPONSOR AND TITLE

Sponsor: U.S. Environmental Protection Agency
Environmental Sciences Research Laboratory
Research Triangle Park, North Carolina 27711

Title: Carbon Fiber Monitoring Research Program

4.3.2 PROGRAM LEADERSHIP

<u>CONTRIBUTOR</u>	<u>ROLE</u>	<u>MAIL CODE</u>	<u>FTS- TELEPHONE</u>
Dr. Jack Wagman	Director/Coordinator	46	629-3009
Mr. R. L. Bennett	Standard Method Development	46	629-3785
Mr. W. D. Connor	Continuous Monitor Instruments	46	629-3894
Dr. R. Shaw	Measurements of Collected Samples	47	629-3148
Dr. C. W. Lewis	Ambient Measurement Instruments and Technology	47	629-3154

4.3.3 DESCRIPTION OF THE PROGRAM

4.3.3.1 PROGRAM OBJECTIVES; ASSIGNED RESPONSIBILITIES

The Environmental Sciences Research Laboratory has been assigned the responsibility for developing the instrumentation and measurement techniques necessary to monitor for air-borne carbon fiber emissions and to define the characteristics of any carbon fibers emitted from manufacturing or waste disposal facilities. The program identified four principal efforts to be undertaken. First was the development of a reference analytical procedure for the positive identification and measurement of carbon fiber emission. This led to the second item, the development of a continuous monitor instrument

capable of detecting carbon fiber emissions within stacks and exhaust ducts. Third, need for measuring carbon fibers in the ambient air resulted in the development of programs to identify and measure carbon fibers collected on membrane filters. Finally, the development of instrumentation capable of providing near-continuous monitoring for carbon fibers present in the atmosphere was delineated.

4.3.3.2 CONTENT OF THE PROGRAM

The continuing program for the development of measurement technology contains an integrated set of elements, each element capable of being performed separately. All of the elements will yield complementary results. The elements are:

A. Characterization of carbon fiber emissions.

This effort utilizes data and samples from present fiber manufacturers, product manufacturers, and disposal operations to estimate the specific characteristics of potential carbon fiber emission. Characteristics of the emissions will be defined in terms of mass concentration, numerical concentration, and size distribution, as well as the chemical, optical and morphological properties of the emitted fibers. The emissions will then be further characterized in terms of potential for damage to electrical equipment and interaction with electrical fields. This phase of the effort provides data for evaluations and comparisons. The data will be applied to the definition of tests and calibration standards for future carbon fiber-sensing instrumentation. It will also be used for comparison to measurements of actual emission cases as encountered. These data will provide the information necessary during the transition from the data presently available from test and measurement to that which will be available when carbon fiber-based composite application and use reach maturity.

B. Analytical standard.

The concept of a standard procedure for positive identification measurement of carbon fiber emissions from stationary sources follows the nominal EPA approach toward airborne contaminants. For this effort, a representative group of carbon fiber-based composite materials will be utilized to produce emissions representative of manufacturing, processing and disposal activities. A systematic evaluation of techniques for sampling,

enrichment, concentration and analysis of the collected materials will lead to a candidate method for identification and characterization of the carbon fibers in terms of numerical concentration, mass concentration, and distribution of lengths and diameters. The problems envisioned are those associated with separation of carbon fibers from extraneous materials. The development efforts will utilize and refine presently known properties of carbon fibers relative to electrical and magnetic conductivity, thermal and chemical stability, and solvent compatibility. The candidate procedure will undergo laboratory and field evaluation in order to establish the degree of sensitivity, precision and accuracy of the procedure.

C. Continuous monitoring instrument.

The potential for carbon fibers to escape through ventilation systems or the stacks of incinerators showed the need for a sensing system capable of the continuous monitoring of gas streams moving in such ducts. The development of a candidate system envisions the adaptation of an existing fiber sensor configuration, either drawn from the carbon fiber-oriented programs or based on sensors developed for other types of fibers. The first phase of the development consists of a review and comparison of existing sensors relative to potential use in a continuous monitor application. The output of the comparison and evaluation study defines a candidate configuration for development. The second phase proceeds with the development of the candidate sensor system. It includes construction of a prototype and subsequent laboratory and field evaluation testing. The capability of continuously monitoring emissions from stacks and ducts was assigned a high importance, resulting in the initiation of parallel, independent efforts. Four organizations have been commissioned to make evaluations and generate a candidate design, with the option existing to proceed with development of a prototype for a continuous monitor instrument.

D. Measurement of fibers collected on membrane filters.

One of the well-established EPA air sampling techniques collects airborne contaminants on membrane-type filters. Investigations of

contaminants in ambient air will generally utilize such sampling techniques; therefore, the ability to measure carbon fibers collected on membrane filters is needed. A technique which will result in mass and numerical concentrations and length distributions must be able to discriminate carbon fibers obscured by other airborne contaminants, many also containing carbon. The development of carbon fiber measurement techniques must be consistent with other well-established measuring techniques. Therefore, the efforts specify three general approaches for development. The first will utilize microscopy; the second, elemental analysis (catalytic combustion); the third, light scattering. A fourth technique, of unspecified approach, is desired. The approach to the development involves preparing filter elements combining representative samples of airborne contaminants with a known quantity of carbon fiber. The quantity of carbon fiber corresponds to best estimates of potential emissions and ranges from one to more than a hundred fibers per filter. These filter samples are then measured by candidate techniques within each of the four areas of general approach. Results of the measurements, evaluated in terms of accuracy and repeatability of measurement, then serve to identify the optimum technique for each of the general approaches.

E. Development, equipment and methods for atmospheric measurements.

The need to measure carbon fiber emissions in the vicinity of potential sources and to be able to assess problems related to airborne carbon fibers gave rise to a development program to define a continuous monitor sensor system for airborne carbon fibers. The development effort stems from the present technology and instrumentation for airborne particulate contaminants and utilizes data from the NASA Risk Assessment and other carbon fiber programs to support the studies and evaluations leading to a candidate configuration. The candidate configuration for the continuous monitor unit will undergo laboratory and field testing to establish prototype units. A supporting and companion effort will address collection and sampling efficiency. Studies and evaluations involving the aerodynamics of airborne particles

and fibers will result in a recommended inlet geometry for the continuous monitor unit. These studies will be based upon present technology for the collection of aerosols and will utilize data from carbon fiber testing in order to generate a configuration which optimizes the efficient collection and sampling of airborne carbon fibers.

4.3.3.3 OUTPUTS; PRINCIPAL MILESTONES

The ESRL effort has imposed milestones which will define and pace the development of a capability for measuring and monitoring carbon fiber emissions. These milestones and target dates are:

- A. Selection of a candidate design for development of a continuous monitor instrument for duct and stack applications (preliminary design). April, 1980.
- B. Development of a standard analytical technique or procedure. December, 1980.
- C. Development of a measurement technique for carbon fibers collected on membrane filters, based on microscopy and elemental analysis. June, 1981.
- D. Development of instruments for continuous monitoring, in-duct type only. April, 1981.
- E. Development of instruments for continuous monitoring of ambient emissions. September, 1981.

4.3.4 CONTRIBUTORS AND ROLES

The ESRL will execute its development program and obtain support through funding transfers, grants to Universities, and research and development contracts with industrial organizations.

4.3.4.1 FUNDING TRANSFERS TO OTHER FEDERAL AGENCIES

The Lawrence Berkeley Laboratories, CA, of the U.S. Department of Energy, will develop a continuous monitor instrumentation system.

4.3.4.2 GRANTS TO UNIVERSITIES

- A. The University of Arkansas will develop a new fiber-compatible inlet for existing samplers.
- B. The University of Minnesota will perform the studies leading to an optimized inlet configuration

for the continuous monitor instrument system. Both developments will benefit from these studies; however, the work will proceed in concert with the efforts at the Lawrence Berkeley Laboratories.

4.3.4.3 RESEARCH AND DEVELOPMENT CONTRACTS WITH INDUSTRIAL ORGANIZATIONS

- A. Battelle Laboratories, Columbus Ohio. The Battelle Laboratories will perform two elements of the program:
 - 1. Characterization of carbon fiber emissions.
 - 2. Development of the analytical standard procedure for carbon fibers.
- B. The Bionetics Corporation, Hampton, Virginia. The Bionetics Corporation will contribute to two elements of the program:
 - 1. Development of a technique for measuring carbon fibers collected on membrane filters.
 - 2. Development of a continuous monitor system for in-duct applications. The evaluations and developments are based upon test program experience gained during the NASA Risk Assessment Program.
- C. GCA Corporation, Bedford, Massachusetts. These efforts will lead to the development of a monitor instrument based upon the company's fibrous aerosol monitor unit.
- D. A. D. Little Corporation, Boston, Massachusetts. ADL will propose a continuous monitor system for stack and duct applications based upon its experience with the U.S. Navy and the NASA Risk Assessment Program.
- E. TRW, Redondo Beach, California. TRW will undertake the development of a continuous monitor system for duct application based upon its experience with pool fire and other related testing gained in support of the United States Air Force.

4.3.5 INTERAGENCY DATA EXCHANGES

4.3.5.1 DATA GENERATED BY THE EPA-ESRL PROGRAM

The ESRL-sponsored effort in the development of measurement techniques and continuous monitor instrumentation will result in publications and reports covering the following areas:

- A. Results of a laboratory evaluation of carbon fiber dust from the machining and oxidation of virgin carbon fiber at elevated temperatures. Data published as a report.
- B. Carbon fiber emission studies.
 1. Characterization of emissions from manufacturing and other stationary sources.
 2. Studies of release mechanisms, dispersion and fallout.
 3. Studies of methods for locating and operating collecting or sampling equipment.
- C. Carbon fiber emission simulation studies and equipment.
- D. Analytical techniques for measurement of collected airborne fibers.
- E. Continuous monitor instrumentation systems. Comparison, evaluation and system configuration of units intended for duct or stack applications.
- F. Continuous monitor sensor systems for ambient airborne fibers; system studies and configurations.

4.3.5.2 DATA OF VALUE TO THE EPA-ESRL

The ESRL development program can utilize data of the following types:

- A. Carbon fiber release test results.
- B. Electrical equipment vulnerability test results.
- C. Carbon fiber instrumentation and carbon fiber dispensing equipment. The data and information include design experiences, operating experiences and the results of problem resolution.
- D. Potential source locations for carbon fiber emissions.

E. Carbon fiber characteristics, data, size, form of manufacturer, results of thermoconditioning, etc.

F. Experiences from carbon fiber release incidents or accidents.

4.3.6 SCHEDULE

Figure 4-1 shows the present schedule for conduct of the ESRL program.

4.3.7 FUNDING

The ESRL has an overall budget assignment of approximately 2.0 million dollars, with commitments now showing approximately 1.2 million dollars distributed as follows:

A. Funding transfer to the Department of Energy - \$240,000.

B. Research grants - \$185,000.

C. Industry - \$780,000.

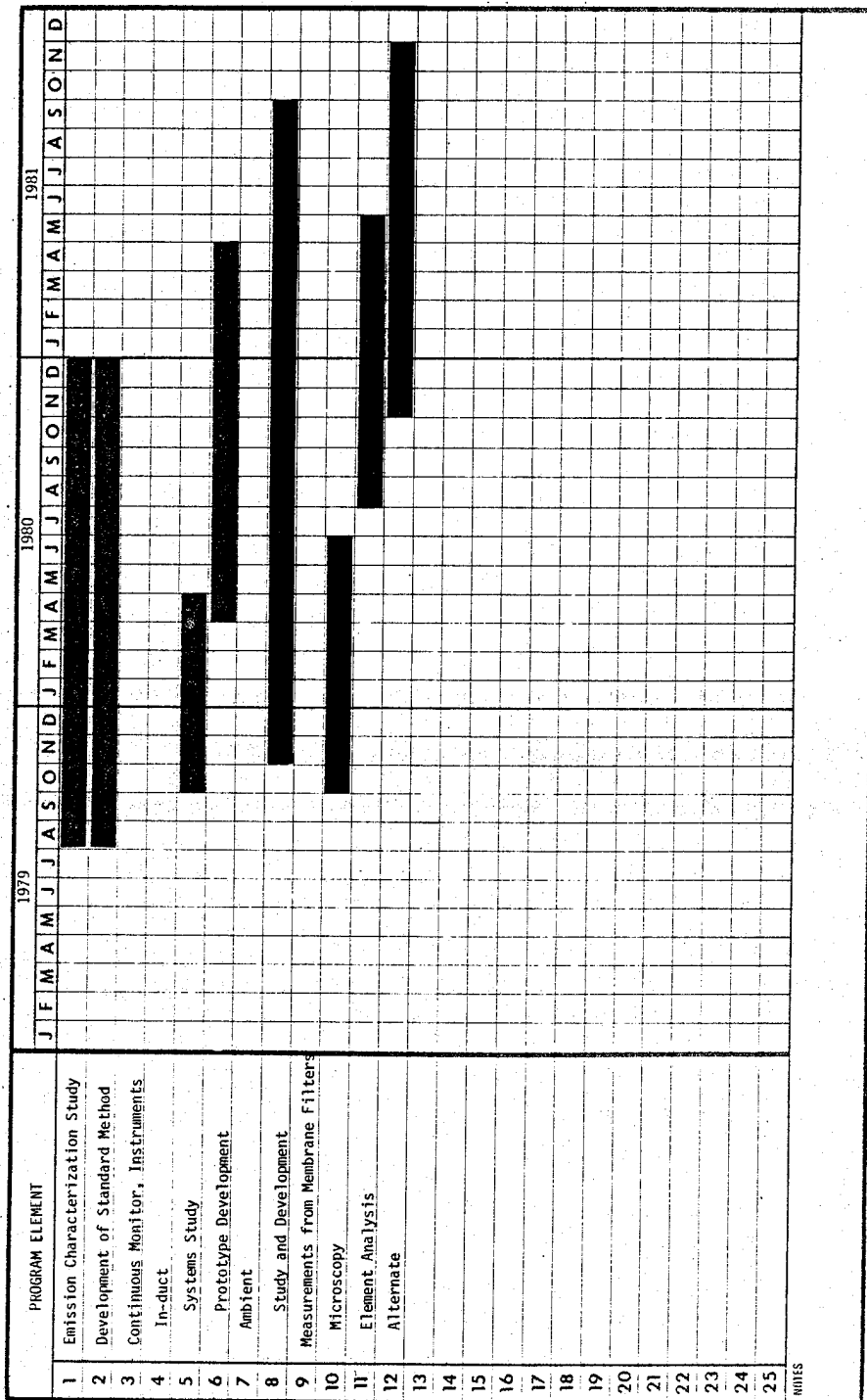

Figure 4-1. EPA-ESRL Carbon Fiber Program Schedule.

4.4 PROGRAM FOR THE FEDERAL AVIATION ADMINISTRATION

4.4.1 SPONSOR AND TITLE

Sponsor: Federal Aviation Agency, U.S. Department of
Transportation

Title: Monitor and Reporting for Aircraft Accidents
Involving Carbon Fiber Composites

4.4.2 PROGRAM LEADERSHIP

Mr. A. E. Anderjaska
Agency Coordination
Telephone: FTS 426-8382
(202) 426-8382

Mr. W. Brennan
Accident Investigation
Telephone: FTS 426-3120
(202) 426-3120

Address: Federal Aviation Agency
AWS 120
800 Independence Avenue
Washington, D.C. 20456

4.4.3 DESCRIPTION OF THE PROGRAM

4.4.3.1 PROGRAM OBJECTIVES, ASSIGNED RESPONSIBILITY

The FAA was assigned the responsibility of monitoring accidents to civil aircraft which involved carbon fiber composites and notifying the Department of Defense of the need to make measurements at the crash site for evidence of a carbon fiber release. The assignment utilized the Duty Officer of the FAA Flight Standards Office which maintains 24-hour surveillance of aircraft accidents. The measurements to determine the presence of released carbon fiber utilize the Mitre-developed sniffer; hence the need to notify the DOD for support.

4.4.3.2 CONTENT OF THE PROGRAM

The implementation of the monitor function consists of maintaining a listing of all civil aircraft which employ carbon fiber composites as elements of structure. In order to

accomplish this, the FAA has integrated a carbon fiber designation into its existing system of aircraft identification by certification number ("tail number"). In the event of an accident report, the tail number listing is consulted, and those aircraft utilizing carbon fiber composites will be identified from a recognizable notation in the listing. Determination that the aircraft involved contains carbon fiber materials will lead to the initiation of a call to the DOD for support from a measurement team.

In all other respects, the response to an aircraft accident will follow the established procedures. The NTSB draws upon the capabilities within the FAA through both regional offices and Headquarters. The FAA Headquarters Operation also makes an assessment of need for support and of appropriate areas for investigation. Decisions based upon the assessment become the basis for further FAA participation in the investigation of an accident involving civil aircraft.

4.4.3.3- OUTPUTS; PRINCIPAL MILESTONES

The NTSB prepares and issues a report for all civil aircraft accidents. As a participant in the investigation, the FAA contributes to the report and makes recommendations for further actions, including those of the FAA staff. An accident which has the potential for the release of carbon fibers would result in the FAA recommending the distribution of the accident report to the concerned agencies, such as the EPA and the DOD.

4.4.4 CONTRIBUTORS AND ROLES

This effort will be performed within the FAA.

4.4.5 INTERAGENCY DATA EXCHANGES

4.4.5.1 DATA GENERATED BY THE FAA PROGRAM

Those agencies (EPA, DOD, NASA, FEMA, etc.) having an interest in or a concern for carbon fiber composites will receive copies of the accident reports.

4.4.5.2 DATA OF VALUE TO THE FAA

Data from other agencies would contribute to the FAA planning for response to accidents involving aircraft containing carbon fiber composites. Areas of specific interest to the FAA include:

- A. Status and projected use of carbon fiber composites in aircraft.

- B. Experience related to potential fiber release accidents arising from other than civil aircraft.
- C. Fire and thermal characteristics of composites.
- D. Experiences and developments in instrumentation and procedures for detecting and measuring the presence of fibers.

4.4.6 SCHEDULE
4.4.7 FUNDING

This effort represents an ongoing program with no separate scheduling or funding.

4.5 PROGRAM FOR THE FEDERAL EMERGENCY MANAGEMENT AGENCY

4.5.1 SPONSOR AND TITLE

Sponsor: Federal Emergency Management Agency
(Formerly the Defense Civil Preparedness Agency)

Title: Carbon/Graphite Fiber Hazards, Emergency Operating Procedures and Reporting

4.5.2 PROGRAM LEADERSHIP

Mr. Thomas Boven
Technical Information and Briefing

Telephone: FTS 372-6171
(616) 962-6171

Address: FEMA Staff College
Federal Center
Battle Creek, MI 49106

Mr. James Thomas
Preparedness Development Division

Telephone: FTS 566-0550

Address: Federal Emergency Management Agency
1725 "I" St NW
Washington, D.C. 20472

4.5.3 DESCRIPTION OF THE PROGRAM

4.5.3.1 PROGRAM OBJECTIVES, ASSIGNED RESPONSIBILITY

The Federal Emergency Management Agency (formerly the Defense Civil Preparedness Agency) maintains a two-way network for communicating with local fire departments, police departments and other organizations which respond to fires, accidents, explosions, acts-of-war and natural disasters. The FEMA has been instructed to utilize these channels in performing the following functions:

- A. Disseminate the pertinent carbon fiber-related technical information to state and local authorities.
- B. Assist local governments toward the preparation of standard operating procedures for response to emergencies which could result in a potential carbon fiber release.
- C. Establish a mechanism which allows local governments to notify the FEMA in the event of a potential carbon fiber release accident.
- D. Maintain the records of such incidents.
- E. Provide a capability for analyzing any incidents which occur, and distribute such analyses and related data to other concerned Federal agencies.

4.5.3.2- CONTENT OF THE PROGRAM

The FEMA efforts involved two interdependent phases. The first phase consisted of the gathering and dissemination of data and the establishment of a reporting system. The second phase consists of the implementation of an ongoing action to receive and analyze the data in reports from potential release incidents.

Phase I: Dissemination of data; aid to and communication with local governments.

The efforts to communicate with local government involved three activities. The initial item became the drafting and distribution of Civil Preparedness Circular 78-5, Carbon/Graphite Fiber Hazards (May 1978). This circular has been distributed to all regional offices, the FEMA Staff College and Civil Defense Directors at both the state and local levels.

The second element involved the generation of a Technical Briefing on carbon fiber effects as they relate to fires and accident situations. The briefing has been prepared as an audio-visual presentation. The content has been reviewed and modified to reflect the findings from the NASA Risk Assessment Program. The Technical Briefing includes supplementary items in the form of checklists, training exercises and a response message format. These supplemental items provide

information to support the generation of Local Standard Operating Procedures and establish a mechanism for reporting incidents. The Technical Briefing will be distributed to the regional FEMA offices which in turn will make selected briefings to local organizations. The selection of organizations for briefing will reflect considerations such as the presence of carbon fiber manufacturing operations, proximity to aircraft operations and movement of carbon fiber-bearing materials in shipments across the area. The level of utilization of the Technical Briefing will be in concert with the increase of usage for carbon fiber materials.

The third element consisted of the preparation of course material for use in training programs offered by the FEMA Staff College and the National Fire Academy.

Phase II: Data and Analysis of Incidents.

The means for reporting release incidents may be considered as being in place. The efforts to provide an immediate identification of a release incident, the provisions for analysis, and the distribution of results to other Federal agencies will lead to a procedure integrated into the operation of the present FEMA communications center. The principal elements to be included in the procedure are:

1. The identification of carbon fiber incidents for data retention and analysis.
2. The analysis of the incidents in terms of cause, effects, elements of the response and results of the response.
3. The distribution of data to other Federal agencies.

In addition, the FEMA will serve as a clearing house for data and results from carbon fiber release incidents. This function will allow evaluation of the need for improvement of, or modification to, local operating procedures.

4.5.3.3 OUTPUTS; PRINCIPAL MILESTONES

The principal outputs and dates for the FEMA efforts are as follows:

- A. Preparation and distribution of a Civil Defense Circular (78-5). (Completed May, 1978.)
- B. Preparation and incorporation of carbon fiber hazard data into instruction and training courses. (This is a continuing effort.)
- C. Preparation and distribution of the Technical Briefing. (Preparation complete; briefings to begin 1980.)
- D. Record keeping, analysis of incidents and data distribution. (To begin during 1980.)

4.5.4 CONTRIBUTORS AND ROLES

This effort was accomplished within the context of the FEMA. The generation of all presentation materials included formal reviews and comments from other agencies working on carbon fibers. The principal contributions became:

- A. The preparation of Civil Defense Circular materials for training courses, and Technical Briefing by the FEMA Staff College, Battle Creek, MI.
- B. The operation of the data monitor, analysis and distribution system by FEMA Headquarters, Washington D.C.

4.5.5 INTERAGENCY DATA EXCHANGES

4.5.5.1 DATA GENERATED BY THE FEMA PROGRAM

The FEMA will generate the following items of value to other agencies:

- A. Reference materials in the form of the Civil Defense Circular and the Technical Briefing.
- B. Continuing data in the form of analysis and compilations of experience from incidents which involved carbon fibers in accidents, fires or other actions which could lead to a release.

4.5.5.2 DATA OF VALUE TO THE FEMA

The FEMA can utilize data from the following sources to support the dissemination of information and analysis of incidents:

- A. Lists of manufacturers operating with carbon fibers.
- B. Data showing the capabilities and operating limits for sensing, counting and discriminating carbon fibers.
- C. Results of studies defining health hazards from partially burned fibers.
- D. Results of measurements on fiber emissions from manufacturing or disposal operations.

4.5.6 SCHEDULE

4.5.7 FUNDING

This effort represents an ongoing program with no separate scheduling and funding.

5.0 LIFE CYCLE EVALUATIONS OF CARBON FIBERS IN COMMERCE

5.1 GENERAL

Surveys of carbon fiber-based materials as they move through the life cycles of typical commercial applications permit assessments of potential for release and can identify specific areas or activities that present the potential for an uncontrolled release. The surveys include the life cycles for transport aircraft, automobiles, sporting goods and medical prosthetic or orthotic devices. The life cycle evaluations first identified the principal elements or features in the life cycle and then delineated the flow of events in order to show the principal alternate pathways which can occur during the life cycle. Assessments of emissions and identification of areas of concern for accidental release were based on these evaluations.

During the life cycle, carbon fibers and composites move under varying degrees of process control. When carbon fibers move according to predefined procedures and with records of transactions, they are considered under control. For many industries, such controls extend to the disposal of scrap.

Virgin carbon fiber and prepreg are shipped in packages with prominent labels describing the potential electrical hazard from uncontrolled release and identifying landfill as the approved method for disposal of scrap. For the purposes of the Life Cycle Evaluation, carbon fiber materials are considered to have a controlled disposal when the individuals and organizations involved could be reasonably expected to have an awareness of carbon fiber effects. In addition, controlled disposal assumes some record of action or agreement between the scrap maker and the individual or organization who actually processes the scrap into a disposal facility. On the other hand, uncontrolled disposal infers an action on the part of an individual who may not be knowledgeable of carbon fiber effects. In this case, the individual places carbon fiber composite scrap in containers or piles whose contents may eventually enter municipal waste streams undetected.

The life cycle of any manufactured product involves a degree of transport, with the attendant possibility of accident. Carbon fiber tow, *per se*, is not considered a hazard during transport, as it is non-toxic, inert, and packaged to prevent accidental damage and consequent release of fibers. Likewise,

impregnated fibers (cloth, tape, etc.) do not, in themselves, present any hazard during transport. Only in an accident involving fire is there a potential for airborne release of carbon fibers. However, burn tests on spools of tow show that the more graphitic fibers (e.g., Celanese GY-70) will not sustain combustion, while the less graphitic fibers (e.g., Thornel-300) will continue to burn like lumps of charcoal. The impacts of transport crash-and-burn incidents have been described and calculated by the Risk Analyses conducted by the NASA and by the DOT. Such accidents are not considered as threats in the context of life cycle considerations.

5.2 LIFE CYCLE FOR CARBON FIBER COMPOSITES IN TRANSPORT

AIRCRAFT

The principal elements and the sequence of events in the life cycle of carbon fiber composites in commercial transport aircraft have been summarized in Figure 5-1. Table 5-1 lists the considerations which constrain the actions involving carbon fiber composites in transport aircraft.

Transport aircraft require complicated structural shapes; as a result, the fabrication process will generate a quantity of scrap and spoilage. Manufacturing operations must proceed under strictly controlled procedures and inspections since the strength and stability of composites depend upon the precise control of process variables. Certification of the part for use in flight requires proof of process control as well as assurance of quality confirmed by non-destructive tests and measurements. Consequently, composite fabricators supplying the aircraft industry have in place methods for control of carbon fibers from incoming raw stock to disposal of scrap and spoilage.

At present, U.S. transport aircraft manufacturers make major use of subcontracts to other firms in the industry. As a consequence, the lay-up, impregnate, and cure cycle for the fabrication of individual parts of a transport airplane will involve more than one factory (e.g., Grumman in Georgia will make the spoilers for the Boeing 767); some parts may be produced offshore (e.g., Bristol of England makes floor panels for the Boeing 747).

Sub-unit assembly adds the fairings, hinges, bushings and other elements required to complete the manufacture of a unit (an elevator, a rudder, an aileron, etc.). These activities involve the drilling or reaming of holes, some trimming or fitting, and the placement of fasteners, rivets or bolts. These operations produce some carbon fiber debris, and occasionally result in the spoilage of a unit. Work proceeds under close inspection and quality controls, either at the subcontractor or within the airplane factory. The airplane industry and its suppliers are knowledgeable of carbon fiber hazards and are aware that landfill is the recommended disposal method.

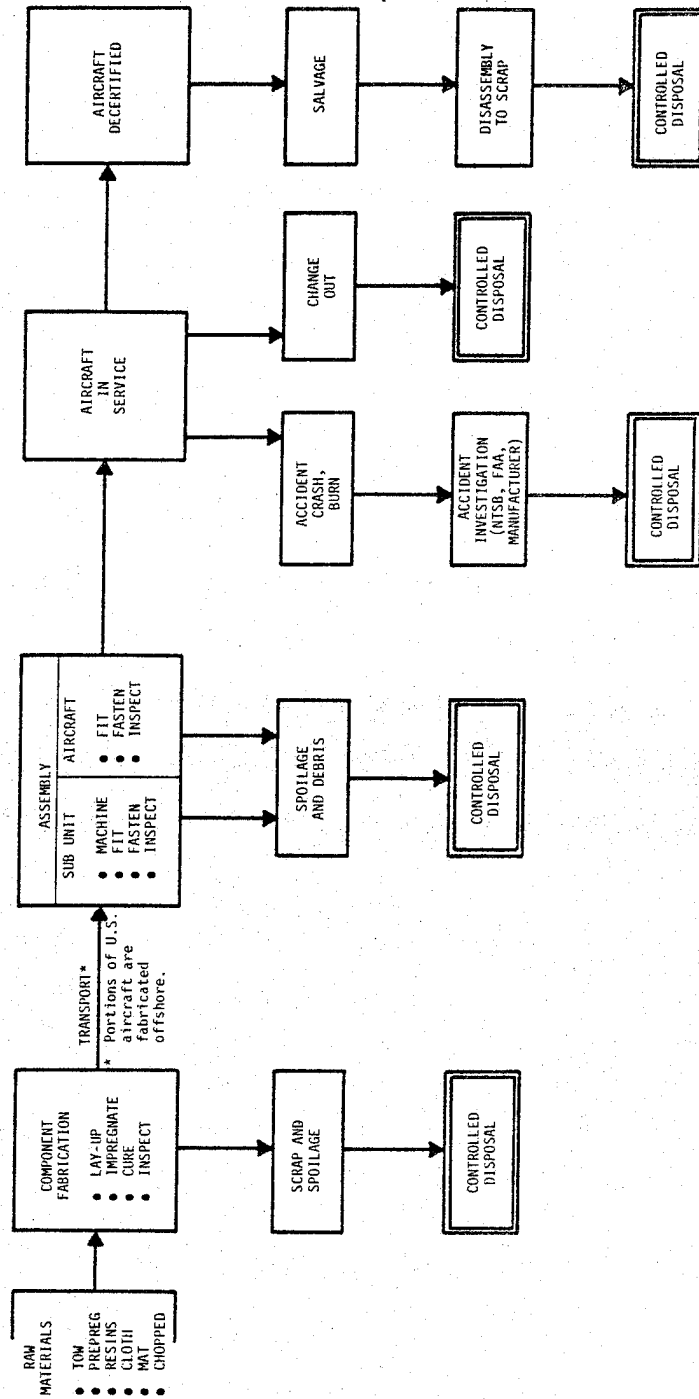

Figure 5-1. Carbon Fiber Composite Life Cycle in Aircraft.

TABLE 5-1

LIFE CYCLE CONSIDERATIONS FOR CARBON FIBER
COMPOSITES IN TRANSPORT AIRCRAFT

Pre-Product Stage:	High quality facility and staff with quality control and disposal controls.
Product Manufacturing Stage:	Limited number of sources. Operate under tight quality and inventory controls. Sophisticated staff and facility.
Product Damage/Burn:	Some risk of crash/burn release. Concern for in-service damage of large sized pieces requiring replacement at dispersed airport sites and cut-up or packaging of damaged pieces for disposal. Factory may require damaged parts for evaluation and final disposal.
Product Repair:	Only minor on-site repairs. Usually, replacement due to FAA requirements for Flight Certification.
Useful Life Cycle:	Typical 10 - 15 year application.
Final Disposal:	Salvage and disposal to industrial waste under controlled conditions.
Summary:	Packaging and disposal of damaged large sized components provides opportunity for release of carbon fiber debris in airport repair areas.

A small fraction of transport aircraft are lost to accidents or crash-and-burn incidents. All accidents involving FAA-certified civil aircraft receive an investigation led by a Federal Agency (usually the NTSB). Accidents involving registered air carriers receive in-depth investigations supported by the FAA. Wreckage from these accidents moves through formalized channels and procedures prior to disposal; in most cases, the manufacturer becomes involved. Carbon fiber composites from airplane crashes will have controls over their disposal.

For those aircraft in active service carbon fiber composites could see change-outs due to service-life limits, local damage, or technology improvement. For example, a component change-out is required after a specified number of hours; a hail battered spoiler is replaced; a part is replaced when an early series resin is superceded by a more moisture resistant alternate. Most of these changes will occur at major airline maintenance facilities; however, an accident, such as an airport service-truck ramming an aileron, may require change-out at a remote location.

Due to the brittle nature of carbon fiber composites, damage to a component may result in microcracks and other damage not easily detectable. The necessity of in-depth inspection largely precludes in-place repair of damaged units. Because of the need for FAA certification, replacement will be the preferred method of repair within the foreseeable future. Aircraft manufacturers will sustain an interest in examining carbon fiber composite units returned from service as part of their on-going quality assurance and technology development efforts. During the service life of an airplane, the carbon fiber composites will receive regular inspections for structural integrity. When removed from the airplane, they will move toward disposal under controlled procedures, very probably through the system of an aircraft manufacturer.

At the end of its useful life, an airplane is decertified by the FAA. It becomes scrap or salvage. Once the reusable equipment (instruments, avionics, auxiliaries, etc.) has been removed, the aircraft becomes high grade scrap. Again, the airlines have controlled procedures for disposing of the hulks. Only in the case of smaller, privately owned aircraft is there a potential for carbon fiber scrap to enter a waste stream unintentionally. Scrapping, part replacement or repair might take place at small, relatively uncontrolled facilities; the personnel involved in the process might be the airplane equivalent of automobile backyard mechanics. By and large, one of the larger single generic applications of carbon fiber composites (aircraft) shows formal controls over each step in the life cycle, from the raw material purchase to ultimate disposal as scrap. Large pieces of aircraft structure will be cut up for

handling prior to entering into the eventual disposal process. However, the nature of the aircraft industry does not present an obvious path for aircraft scrap to move uncontrolled into a municipal waste stream.

LIFE CYCLE CONSIDERATIONS FOR CARBON FIBER COMPOSITES
IN AUTOMOTIVE APPLICATIONS

The sequence and flow of events for carbon fiber composites in automotive applications are summarized in Figure 5-2. The concerns for potential releases of carbon fibers from automotive applications are addressed in summary in Table 5-2. The studies conducted by the DOT do not project a major use of carbon fiber composites in any individual car or truck; however, due to the large number of vehicles produced, the total usage will be substantial. Applications will be selective, reflecting well-engineered utilization of the superior materials properties in areas compatible with production technology and cost. The evaluation program under way within the Ford Motor Company shows evidence of a systematic approach to the selection and use of carbon fiber composites in the forthcoming generation of automobiles and trucks. At present, any particular application is still speculative; however, the properties of carbon fiber composites show good engineering matches for the following types of applications to automotive equipment:

A. Frame Stiffeners.

Strips of carbon fiber composite bonded to the insides of frame rails increase bending and torsional stiffness, similar in application and use to aircraft wingboxes. This application has a particular advantage to truck frames, which are usually straight, constant cross-section channel members.

B. Intrusion beams or guard beams in car doors.
Weight saving eases the design of the supporting hinges and makes the door easier to operate.

C. Sway bars, equalizer bars, and springs.
Reduced weight and size are coupled with improved elastic properties.

D. Push rods for overhead valve engines.
Reduced inertia in the valve linkages for the small displacement, high-speed engines aid in increasing fuel economy.

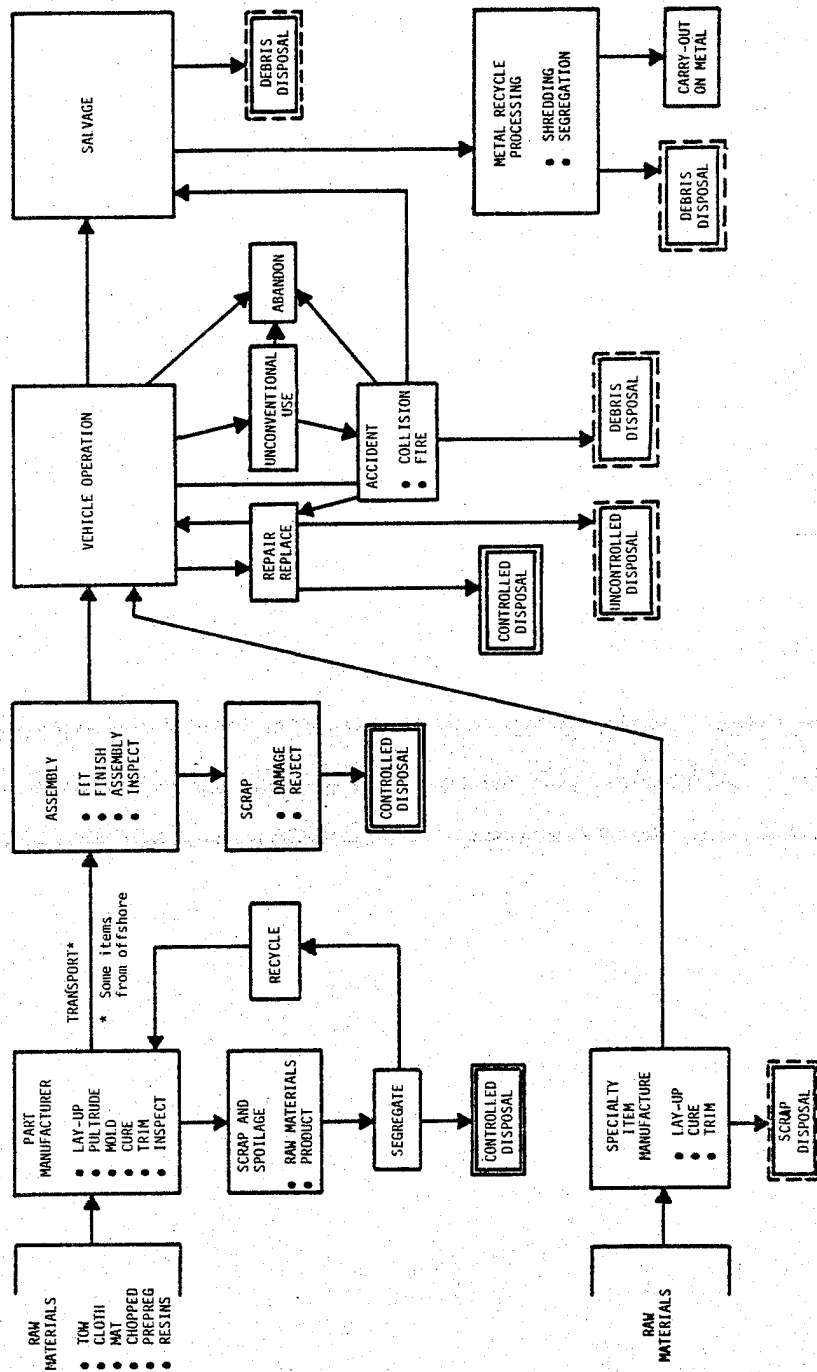

Figure 5-2. Carbon Fiber Composite Life Cycle in Automotive Applications.

TABLE 5-2

LIFE CYCLE CONSIDERATIONS FOR CARBON FIBER
COMPOSITES IN AUTOMOTIVE APPLICATION

Pre-Product Stage:	Commercial manufacturing controls.
Product Manufacturing Stage:	Automobile parts produced by major firms with good disposal controls. Possible poor disposal control on scrap/waste at small parts supply/manufacturing for aftermarket items.
Product Damage/Burn:	Potential release due to burn or damage.
Product Repair:	Not anticipated to a major degree in auto commerce except if used in external body panels.
Useful Life Stage:	Three to 10 years. Wear-release not considered a significant concern.
Final Disposal Stage:	If replaced during life, then the spent part could enter the municipal waste stream, or private disposal, and even recycle into salvage yard for scrap recycle where disposal could be in steel furnace.
Summary:	Release risks exist if auto use increases for carbon fiber. Small manufacturers and small repair garage present a disposal risk into municipal waste streams.

The corrosion resistance exhibited by carbon fiber composites may lead to applications such as water pump impellers and air pumps for emission controls. The market for performance-oriented products may lead to the production of rocker arms for overhead valve engines, connecting rods, lightweight wheel rims, etc. Although the literature search identified driveshafts as an area of development, the trend toward front wheel drive for automobiles leaves trucks as the primary potential application for carbon fiber driveshafts.

The manufacturing of parts for automobiles will involve the present major suppliers to the industry. Production of parts at rates compatible with U.S. assembly volumes precludes participation by any but well-established manufacturing firms operating from well-tooled and well-maintained factories. None of the principal candidate areas for application of carbon fiber composite permits production in other than a major facility. Such operations will be knowledgeable of carbon fiber hazards; all will have well-developed methods for handling scrap and spoilage. The use of molded (injection, blow, press, etc.) parts containing chopped fibers can result in a recycle sequence in which a defective product is ground and reintroduced into the molding sequence. Some molding techniques will tolerate as many as three recyclings without loss of materials properties. Scrap and spoilage from the production of automotive parts will move to disposal under some form of control.

The incorporation of carbon fiber composite parts into assemblies implies transport, and some of the parts may be fabricated offshore. Assembly operations may occur in more than one factory. For instance, individual engine parts move to an assembly facility for engines. The engines may then be shipped to another location for final assembly into a vehicle. Frames, transmissions and drive axles follow similar patterns. Assembly operations do not involve cutting and forming. However, scrap may result from breakage, damage in handling, or rejection at inspection. This relatively small amount of scrap material will move under controls into disposal.

The production of after-market specialty items may present a possibility for production scrap from carbon fiber materials to move uncontrolled into a waste stream. The production of small items, such as rocker arms or connecting rods, could originate from organizations relatively inexperienced with carbon fibers. The Literature Search has shown some evidence of small organizations attempting to build automotive parts, but only remaining in business for a short period of time. No present method exists for identifying such ventures in advance of production; no measures exist which assure control over carbon fiber materials during production. Fortunately, the successful application of carbon fibers to products used in automobiles will require an established engineering capability

in addition to a good production facility. As a consequence, relatively few "garage" type operations are likely to succeed.

The operating life cycle of automobiles and trucks indicates some opportunities for carbon fiber composites to escape from control and enter municipal waste streams. Unless carbon fiber composites become elements of body structure, repair of composites will be rare. In most cases, the composite item would be replaced and the spent item scrapped. Repairs performed in dealer or fleet maintenance facilities should have adequate controls for disposal. On the other hand, the local garage or the backyard mechanic cannot be expected to have a knowledge of carbon fiber hazards. These may become sources for the uncontrolled entry of carbon fiber-bearing material into municipal waste streams. The potential exists that, in rural areas, small operations will continue to do open burning, presenting the opportunity for the release of airborne carbon fibers.

The impact of vehicle accidents has been addressed in the risk analysis performed by the Department of Transportation. The clean-up after an accident offers an occasional opportunity for swept debris to carry a small amount of shattered or burned carbon fiber composite into a municipal trash container.

The current prices for shredded and separated steel scrap have resulted in an increased recycling of automobiles through shredding plants. In fact, the rate for shredding old automobiles presently matches the production rate for new automobiles. A continuation of this trend would tend to funnel most of the junked automobiles into a recycling sequence. For carbon fiber based composites in automobiles, such a condition would optimize the opportunity for salvage or reclamation of fiber, should applicable techniques evolve. At a minimum, a continued emphasis on recycling automotive scrap must lead to addressing the problem of the presence of carbon fibers in the debris at junk yards, and in the fallout from shredders. The composition of the debris will either require some degree of control over the disposal technique permitted or necessitate the separation of carbon fiber composites from other materials in the debris. In effect, junk yards and shredders have the potential to bring about local concentrations of scrap carbon fiber composites. For those composite items which remain attached to a shred of metal, consignment to a melt furnace does not appear to result in a hazard. Carbon fibers float on molten aluminum; debris would be trapped in the scoria. In molten iron, carbon fibers will either dissolve or be trapped in the slag.

To summarize the impact of carbon fiber composites in automotive equipment, three major elements appear in the consideration for disposal.

- (1) During manufacture and while vehicles are maintained by either factory-based or fleet-based facilities, controls are available over municipal waste stream entry of carbon fiber composites.
- (2) Through the actions of untrained individuals or as a result of accidents, a portion of the carbon fiber composites will make uncontrolled entries into municipal waste streams.
- (3) The continuation of an attractive price for shredded scrap will eventually bring about the need for junk yards and shredder facilities to address the concentration of carbon fiber in the debris resulting from the recycling of automotive scrap. This consideration may justify further investigation by the EPA into the types and quantities of debris which result from the shredding of automobiles.

5.4 LIFE CYCLE CONSIDERATIONS FOR CARBON FIBER COMPOSITES
IN SPORTING GOODS

The life cycle of carbon fiber composites in sporting goods has been summarized in Figure 5-3. Table 5-3 lists the considerations pertinent to the life cycle for sporting goods. Carbon fiber composites have a well-established application in premium quality golf clubs, tennis racquets and fishing poles. Carbon fiber composites are experiencing an expanding use in premium quality skis and ski poles. In addition, the material finds applications in canoes and competition-class sailboats. Established manufacturers of sporting goods produce the bulk of carbon fiber-based items offered to the public. Most of these firms have both domestic and offshore production facilities. Consequently, the production path for some items involves overseas transport. The operations which involve the lay-up, impregnating and curing of the composites will be performed by organizations aware of carbon fiber hazards.

Final disposal of the product will be uncontrolled. Fortunately, because of the premium price, the first owner of an item will tend to protect it from loss or damage. In normal use, however, the material will outlast the original owner; the second, or third, or inherited owner will likely make the final disposal of the item. Eventually, carbon fiber sporting goods will be thrown away and thereby enter municipal waste streams uncontrolled. Some sporting goods offer the potential for loss in a manner which precludes entering a waste stream: a fishing rod lost overboard, a boat shattered and sunk. Damage or breakage is a more probable event, particularly for competition-grade items. Some items will offer the potential for repair. The technology associated with repairing carbon fiber composites precludes any action but return to a manufacturing facility. Repair cycles will represent controlled conditions until the item is returned to the owner.

In summary, the production sequences for carbon fiber composites in sporting goods will not generate any inputs to municipal waste streams. The principal disposal path for damaged, obsolete, or spent items, however, appears to be into municipal waste streams. All the items manufactured to date will enter a waste stream sometime in the future; the quantity entering waste streams will eventually come into a near equilibrium with the quantity of new production. At that time, the total U.S. inventory of carbon fiber composites in sporting

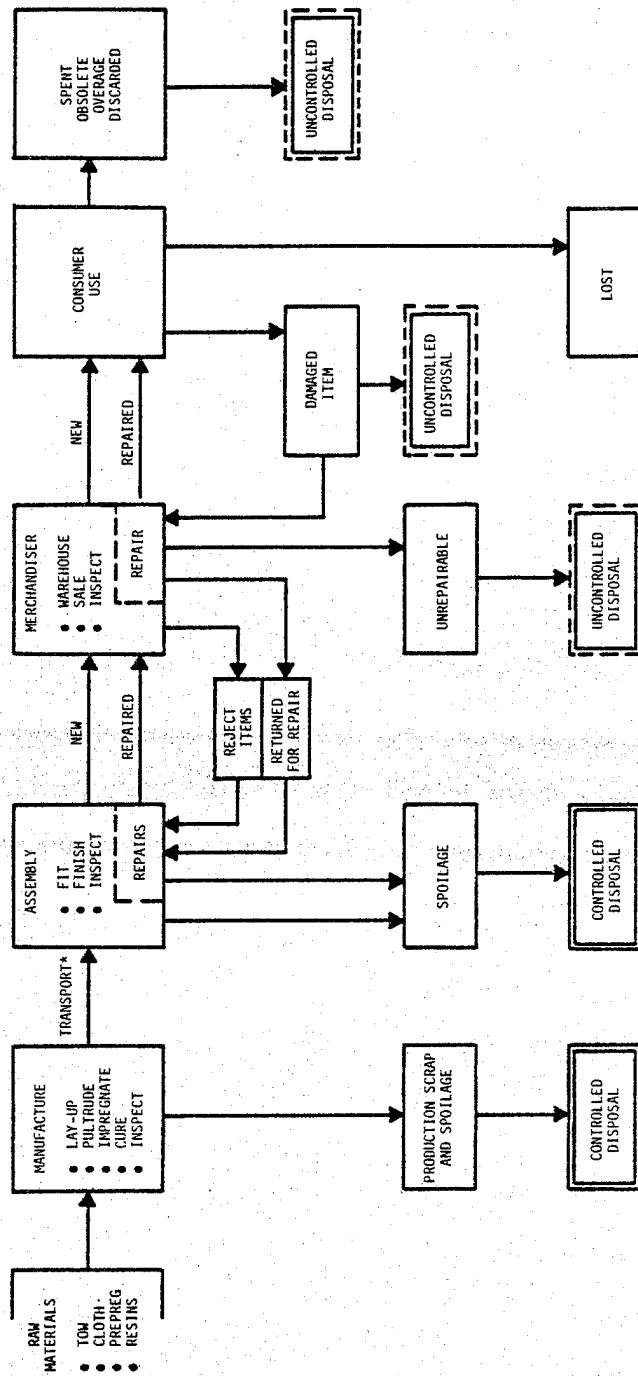

* Transport between manufacturing and assembly operations can involve shipment to offshore factories and return.

Figure 5-3. Carbon Fiber Composite Life Cycle in Sporting Goods.

TABLE 5-3

LIFE CYCLE CONSIDERATIONS FOR CARBON FIBER
COMPOSITES IN SPORTING GOODS APPLICATION

Pre-Product Stage:	Same as general commercial fiber production.
Product Manufacturing Stage:	Limited sources. Sophisticated, quality facilities with disposal controls.
Product Damage/Burn:	Very improbable events for quality goods in the hands of serious users.
Product Repair:	Infrequent requirement. Limited release prospect.
Useful Life Stage:	Long life span. Occasional loss or breakage, with no release of free fibers.
Final Disposal Stage:	Enter general municipal waste stream.
Summary:	Not a significant problem of release until well into the future.
Contingency:	Expansion into the recreational vehicle field in a quantity production could increase the amount of automotive-based scrap.

goods could equal the total of a number of years of production. Should a technology for reclaiming carbon fibers develop, the combination of factories and dealerships offers a basis for an effective means to recover products for recycle.

5.5 LIFE CYCLE CONSIDERATIONS FOR CARBON FIBER COMPOSITES
IN MEDICAL APPLICATIONS (PROSTHETIC AND ORTHOTIC
DEVICES).

The sequence and flow of events for carbon fiber composites used in external prosthetic or orthotic (supportive) applications is summarized in Figure 5-4. Table 5-4 lists the principal considerations pertinent to the use of carbon fiber composites in such applications. At present, the use of carbon fiber composites in medical applications can only be considered speculative. However, the combination of light weight and high strength makes carbon fiber composites attractive for such applications. The NASA-Langley Research Center, Materials Division, has engaged in a continuing effort in support of such applications. These efforts are focused and funded through a contract with a rehabilitation center in Mississippi. The development efforts have addressed the orthopedic devices associated with correcting a difference in the length of legs; the design of an implanted aneurysm clamp; and the preliminary design of a lightweight wheelchair. These efforts, coupled with the interest in implants revealed in the Literature Search, indicate that the medical profession will become a well-established user of carbon fiber composites.

For the foreseeable future, the manufacture of externally worn prosthetic or orthotic items will utilize standardized production shapes and sizes (tubes, bars, plates, etc.). The manufacturing procedures for the basic elements of leg braces, crutches and similar devices are not expected to involve extensive lay-up and cure operations by the fabricator. An established manufacturer of composites will supply most of the "building blocks" which become part of a prosthetic device; the scrap from the manufacturing of these forms will not make uncontrolled entries into municipal waste streams.

Present manufacturers of prosthetic and orthotic devices work closely with hospitals and medical centers. The application of carbon fiber composites will proceed on a gradual basis. Manufacturers will employ composites in response to application developments. Initially, they will follow the leads provided by such activity as the NASA-sponsored effort. As technology grows, these firms will make their own innovations and develop new applications.

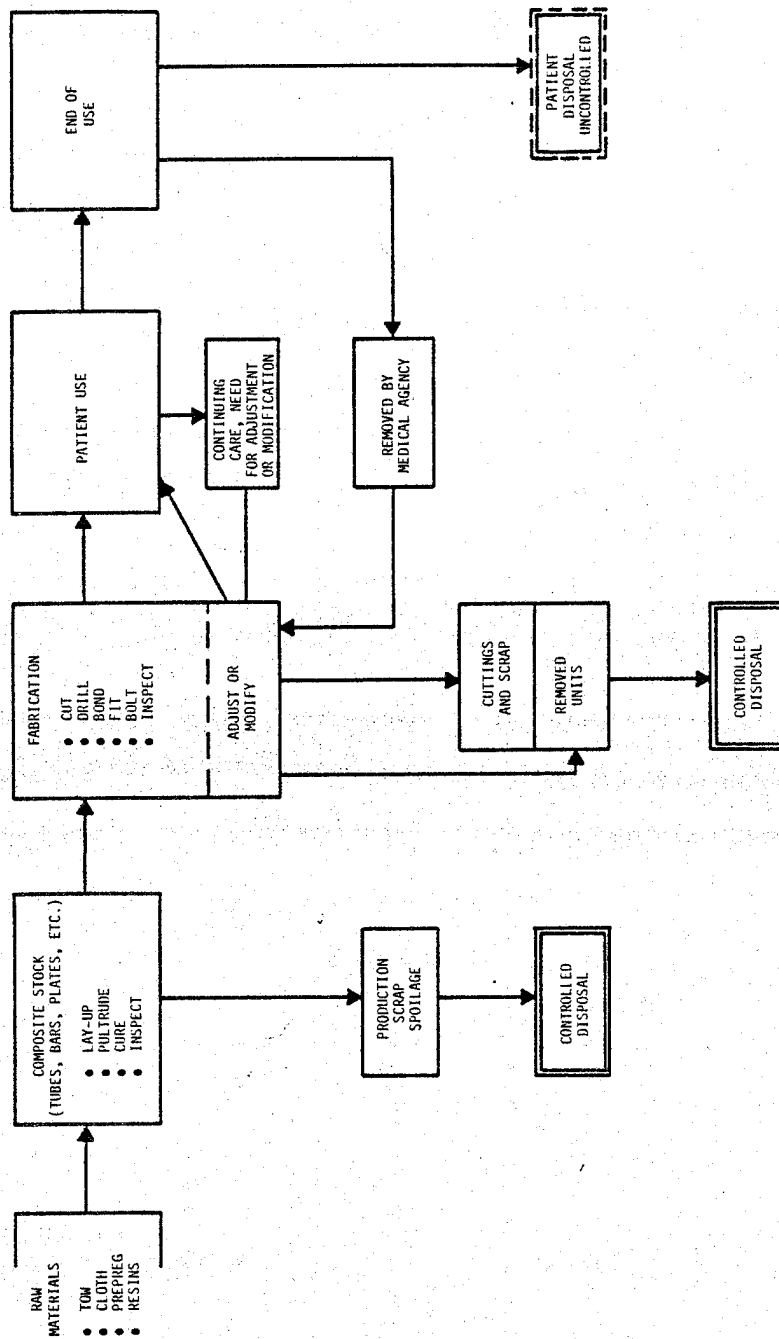

Figure 5-4. Carbon Fiber Composite Life Cycle in Medical Applications.

TABLE 5-4

LIFE CYCLE CONSIDERATIONS FOR CARBON FIBER COMPOSITES
IN MEDICAL APPLICATIONS (PROSTHETIC AND ORTHOTIC DEVICES)

Pre-Product Stage:	Commercial sources supply rod, bar, plate stocks.
Product Manufacturing Stage:	Medical technology lab, typically a hospital-affiliated facility with specialized and sophisticated staff. Operations are principally drilling, bolting, bonding.
Product Damage/Burn:	Improbable events, minor damage with no release.
Product Repair:	Occasional refit/replace by medical professional.
Useful Life Stage:	Several months to several years with intermediate checks by the initial supplier for patient progress.
Final Disposal Stage:	Usually by medical professional or initial manufacturing facility after final check of patient. Medical facility disposal.
Summary:	Small prospect of entering a municipal waste stream.

Presently, only a limited number of orthotics manufacturers are using carbon fiber composites and are, therefore, aware of carbon fiber hazards. As use expands, additional firms will acquire capability in the application of carbon fibers to orthotic or prosthetic devices. Because of the professional character of the industry, these manufacturers can be expected to be aware of carbon fiber hazards, and the disposal of scrap will be under controlled conditions.

Prosthetics or orthotics worn or used by patients require periodic adjustments or modifications. These adjustments stem from physiological changes in the patient (e.g., his weight can change) or from recovery from the condition which necessitated the orthotic device (the damaged area heals). In some cases (crutches, braces), when the need for the device disappears, the supplier removes and disposes of the spent unit. In some cases, the patient (or his survivors) eventually dispose of the unit; here a municipal waste stream can become the path for disposal of a spent device.

In summary, for carbon fiber composites applied to externally worn orthotic or prosthetic devices, disposal will be controlled as long as the device remains under the care and maintenance of the fabricator or of a treatment center. In the case of items in extended use, either outgrown by a patient or outliving the user, such devices have the potential to enter municipal waste streams in an uncontrolled manner.

6.0 EVALUATION OF DISPOSAL TECHNIQUES

6.1 GENERAL

The evaluation of disposal techniques addresses the potential for releasing airborne carbon fibers as a result of the introduction of carbon fiber composites into the waste stream feeding a particular disposal system. The evaluations include existing disposal techniques as well as techniques currently under development. The data for the comparisons draw from the results of on-site surveys of mass-fired incinerators used for steam generation and of processing operations for refuse-derived fuel, as well as from fire-release data generated during the NASA Risk Assessments.

In the evaluations, the disposal methods were divided into two fundamentally different types, bulk disposal (landfill, recycle, etc.) and disposal by combustion/oxidation. In either type of disposal, crushing or shredding operations may precede the final disposition: more efficient use of landfill volume results from the compaction of crushed materials; many oxidation disposal processes require the shredding of large pieces to assure efficient combustion or to facilitate their injection into the oxidizing chamber. The evaluations considered combinations of techniques. For example, a high scrap value for carbon fiber could make recovery of composite an economically feasible operation. Conversely, carbon fiber composites may warrant extraction from a waste stream for routing to an appropriate incineration facility.

The discussions of disposal techniques define the criteria for evaluation and include a summary of the results from fire release testing. These criteria and data are then applied to each of the candidate disposal methods.

6.2 CRITERIA FOR EVALUATION OF DISPOSAL TECHNIQUES

6.2.1 HAZARDS FROM CARBON FIBERS

Since the electrical and health hazards associated with carbon fibers are related to single airborne fibers, the primary consideration has been to assess the potential for release of single carbon fibers into the atmosphere. The carbon fiber composites most likely to enter the waste stream will largely be in the form of discarded, outdated, or damaged finished items. The individual fibers will generally be

embedded in a matrix binder material. These binder materials are usually nonconductive, and the dimensions of the fiber/binder combination are such that passage to the alveoli of the lungs is not possible. Thus, the fibers do not present any hazard as long as they are contained within the composite matrix. Matrix materials have lower melting and ignition temperatures than carbon fibers; in incinerators, the matrix material may burn away and release carbon fibers as free fibers. These free fibers may be completely destroyed in some incineration processes, presenting no hazard. In some instances, the fibers may undergo some oxidation, but not be completely destroyed. Oxidation of the fiber proceeds radially inward, and a reduction of the fiber diameter may result in a fiber of appropriate dimensions for passage to the alveoli of the lungs. In other cases, the fiber may be little oxidized or fragmented, presenting an electrical hazard. Thus, the degree of destruction and oxidation of the fibers in an incineration process becomes an important consideration. Unless the free fiber can be contained within the process enclosure, the potential exists for airborne release, and the concomitant impacts on the environment.

The requirements for effective disposal of carbon fibers must be straightforward. They must take into account the physical characteristics of the fibers. In addition, the exposure or concentration of fibers necessary to cause an electrical failure or a health hazard must be considered. Once an acceptable limit for the amount of airborne carbon fibers is defined, the criteria for evaluation of the adverse impact on the environment of a carbon fiber release are as follows:

- A. the probability of fibers becoming airborne;
- B. the characteristics (dimensional, electrical, etc.) of the released fibers;
- C. the duration and magnitude of the release.

In terms of the development of the evaluation of disposal techniques, the first of these considerations is most important. This will be approached by sequentially developing the following three areas:

1. Release of fibers from the composite matrix.
2. Fiber oxidation and/or destruction.
3. Process retention of fibers.

6.2.2 RELEASE OF FIBERS FROM COMPOSITE MATRIX

This area has been the subject of considerable effort in evaluating the potential for release of fibers from composites used in aircraft in the event of an accident involving fire. These studies have concentrated on the release of single fibers with lengths greater than 1.0 millimeter. These fibers have the greatest potential for causing electrical problems: single fibers can be transported great distances; fibers longer than one millimeter are long enough to bridge the air gaps between electrical contacts. In tests, carbon fiber composite samples were burned for 20 minutes over a propane burner with various types of disturbance. Fibers released during burning were analyzed, providing a data base which can be used to evaluate the release of carbon fibers in various waste combustion processes. The percentage of input weight of carbon fibers which were released as single fibers is tabulated below (Table 6-1). The data were taken from NASA TM 80214, Potential Release of Fibers From Burning Carbon Composites, V. Bell.

TABLE 6-1 20 MINUTE PROPANE BURN RESULTS

<u>DISTURBANCE CONDITION</u>	<u>% OF INPUT WEIGHT RELEASED AS SINGLE FIBERS</u>
No disturbance	0.01
air at 5 m/sec	0.3
air at 15 m/sec	1.0
air at 70 to 94 m/sec	2.4
air at 244 m/sec	3.5 to 8
no air disturbance; piece dropped 8 feet	0.08

In addition to the tests for fiber release due to burning of the composite matrix, some work has been done on the nature of particles resulting from mechanical reduction of composite materials by sawing and drilling. Microscopic examination of the particles produced by these operations reveals that the fibers, although fractured, remain bonded to portions of the matrix. Free carbon fibers do not appear to be produced.

6.2.3 FIBER OXIDATION AND/OR DESTRUCTION

The investigations into the potential release of fibers from aircraft accidents also included some examinations of the oxidation and/or destruction of carbon fibers in fires. Given sufficient time and oxygen at high temperature, carbon fibers can be completely oxidized and destroyed. In most cases, however, only partial oxidation occurs prior to release of the carbon fiber from the fire. Carbon fibers as initially produced generally have diameters between six and eight micrometers. Depending on the conditions of burning and release, the radial oxidation of the fiber results in diameters predominantly in the range of two to four micrometers.

In terms of incineration of carbon fibers, it is necessary to recognize that many incineration processes control the amount of oxygen available for combustion. Thermogravimetric studies of the rate of weight loss for "AS" type carbon fibers show that the rate is highly dependent on oxygen concentration. Figure 6-1 shows the results of burning "AS" carbon fibers at 1,000° C with various oxygen concentrations. These results may be expressed in terms of the time required to bring about a 60 percent loss of fiber weight (37 percent reduction in diameter). At a normal oxygen concentration of about 20 percent, such a reduction took place in about 20 seconds. At 8 percent oxygen, a similar reduction required 215 seconds. At about 4 percent oxygen, 270 seconds was required to bring about a 60 percent weight loss. Fibers heated in nitrogen showed a 2 percent weight loss in 360 seconds. Oxygen concentration has a critical effect on the rate of burning of the fibers; conversely, for a given residence time in the burning zone, the degree of oxidation and diameter reduction is a function of oxygen concentration.

6.2.4 PROCESS RETENTION OF FIBERS

Little information is available on the effectiveness of particulate removal processes in removing carbon fibers from gas streams. For systems burning municipal solid wastes, the most common method of removing particulate matter in order to meet emission requirements is by use of electrostatic precipitators. It is known, however, that electrostatic precipitators have difficulty in removing particles with a specific resistance (resistivity) of less than about 1×10^4 ohm-cm. (Chemical Engineer's Handbook, Fifth Edition, pp. 20-110). Carbon fibers typically have a resistance of 2,000 to 5,000 ohms per centimeter of length. Based on a fiber diameter of 7 micrometers, the resistivity of carbon fibers can be estimated at 7×10^{-4} to 2×10^{-3} ohm-cm., far below the range at which electrostatic precipitators are efficient. When such conductive particles strike the collecting plates of the precipitators, they may acquire a charge from the plate and be repelled back into the gas stream. No measurements exist which show the ability of

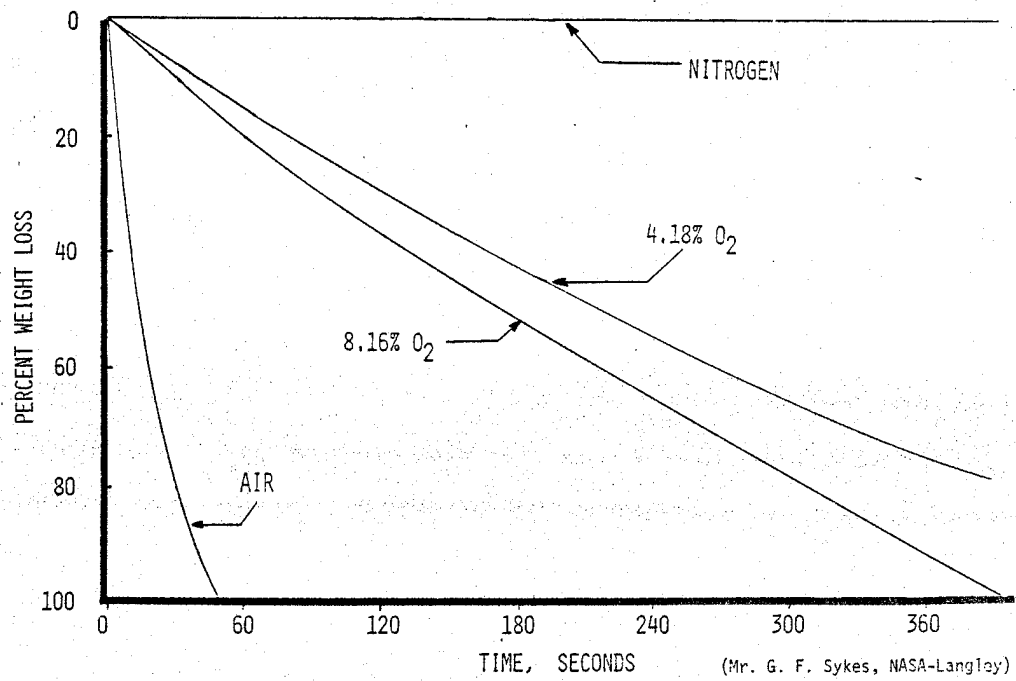

Figure 6-1. Iso-thermogravimetric analyses of "AS" carbon fibers at 1000 °C (1800 °F).

electrostatic precipitators to trap carbon fibers moving with other particles which may shield or insulate them from the plates. In particular, the conditions within a precipitator associated with an incinerator have not been addressed. In this case, carbon fibers represent only a small fraction of the total particulate load and are mixed with particles of higher resistivity. The effectiveness of electrostatic precipitators in removing carbon fibers under such conditions needs to be determined by a test program.

Another commonly used method for controlling particulate emissions is the bag house. In these, the exhaust air is drawn through large filtering bags which trap the particles. The trapped materials are periodically removed by shaking, pulse jet or low-pressure reverse flow.

Bag houses are effective for control of particles with diameters in the range of four to eight micrometers for more or less spherical particles. Measurements show that for these, only 0.2 to 0.4 percent of the particles penetrate a Teflon/glass filter bag. A series of measurements conducted as a part of the NASA Risk Assessment gives some indication that the bag houses may be even more effective on fibers than they are on spherical particles. The NASA measurements showed that ordinary household grade 2-inch furnace filters limited penetration of three millimeter long carbon fibers to about 0.2 to 0.4 percent. These same furnace filters transmit about 20 percent of spherical dust particles. Given the differences in technology and sophistication between bag houses and furnace filters, it is reasonable to assume that the transmission of fibers through a bag house would be less than the transmission of spherical particles. It is expected, then, that bag houses would transmit no more than one-tenth of one percent of fibrous materials.

A third method for removal of particles from incineration exhausts is the wet scrubber. Forms of wet scrubbing which have been applied to municipal incinerators in the past have very often not been efficient enough to satisfy current particulate emission standards, and have resulted in closing of the incinerators or in conversion to electrostatic precipitators. However, properly designed scrubbers using atomizing sprayers can be effective in particulate removal. In the NASA-conducted fire-release tests in the Shock Tube at the Naval Surface Weapons Center in Dahlgren, Virginia, both fibers and soot were effectively removed from a moving air stream. A standard fire fighting fog nozzle was used, and more than 99 percent of all fibers and soot particles in excess of 4 micrometers were removed. These results lead to an expectation that wet scrubbers, specifically designed for removal of airborne particulates, would be at least this efficient.

6.2.5 COMPOSITES MOVING IN THE WASTE STREAM

In the approach to the disposal of carbon fiber composites, two factors must be considered: the total amount of carbon fiber material being processed, and the concentration of such materials in the waste stream. Small volumes of carbon fibers present no great difficulty in disposal; the incineration of a single broken golf club will result in an extremely low probability of electrical or health hazard. Likewise, where carbon fiber composite material is highly concentrated, appropriate disposal methods can be undertaken. For example, the scrapping of a commercial transport aircraft will result in an identified, concentrated mass of carbon fiber materials in the hands of personnel who can be expected to be aware of proper disposal techniques. At the present, the major volume of carbon fiber materials is confined to applications which have an inherent potential for controlled disposal.

As carbon fiber composites are applied to a wider range of uses, the potential for their entry into municipal waste streams grows. Identification of these items may be difficult; the concentration of carbon fiber composites relative to the total waste stream will not exceed a small fraction of a per cent; culling from the waste stream is a remote possibility. Present methods for the separation of specific components from the waste stream are not designed to specifically segregate carbon fibers. For example, in some systems, upward airflow classifiers are used to separate materials on the basis of density. Carbon fibers and composites would become part of the light fraction in this process. This light fraction is usually used as a fuel, so the carbon fiber materials, unconcentrated and unidentified, could enter an incineration process under very little control.

In the following sections, bulk disposal and combustion/oxidation disposal will be discussed in terms of the entry of unsegregated carbon fiber material into the waste stream. In addition, processes applicable to the disposal of segregated carbon fiber composites and materials will be discussed. For each technique, the process will be described. The potential for release of airborne carbon fibers will be discussed in relation to the ability of the process to destroy or contain free carbon fibers. As assessment of the appropriateness or cost-effectiveness of each system will be made.

6.3 BULK DISPOSAL

Two methods of bulk disposal are readily available: landfill, and recycling of the material. For small quantities of concentrated carbon fiber composites, landfill represents a cost effective disposal method, which results in little, if any, carbon fiber release. Such a method appears environmentally acceptable

because carbon is a benign material and is not soluble in any common solvents. Leaching of the carbon fibers from the landfill into ground water is not probable. The material would remain in the ground indefinitely with no adverse effects attributable to the presence of the carbon fibers. A small amount of composite in the form of discarded sporting goods or even automotive components could be accepted in crushers or shredders without producing a sensible release of airborne fiber. On the other hand, production scrap resulting from partial impregnations or containing shredded residue should not be fed into shredders or air classifiers. These types of scrap have the capability to release free fibers in lengths considered a hazard to electrical equipment. Virgin fiber and uncured scrap in proper bags or containers can be processed directly into landfills with little concern for release of airborne fibers.

A remote potential exists for the recycling of carbon fiber composites from the waste stream. Some thermoplastic compounds can be shredded and reused. It is conceivable that a lightweight concrete or paving material could be developed incorporating chopped composite material as a filler or aggregate. The cost associated with the specific removal of composite materials from the waste stream, however, appear to be prohibitive.

In the short term, landfill disposal of carbon fiber composites appears appropriate. At present, these materials represent a small, controlled volume. However, as fiber use increases, the probability of composite materials entering waste streams under uncontrolled conditions increases. Likewise, greater production may lead to volumes of scrap and wastes which exceed landfill capacity. Incineration methods which can effectively dispose of these materials must be considered. More importantly, the impact of the uncontrolled entry of carbon fiber composites into existing waste streams which move towards incineration must be addressed.

6.4 COMBUSTION/OXIDATION DISPOSAL

6.4.1 THE COMBUSTION PROCESS

Combustion of solid materials can be accomplished in several different ways, the method of burning being to some extent determined by the size of the solid material to be burned. Large size solids are burned in a bed with combustion air admitted from beneath. Intermediate size solids may be introduced into the flame zone first, where they are partially burned before falling through this zone onto a bed where their combustion is completed. Very small particles may be burned while being held in suspension in an air stream in much the same manner as an atomized liquid fuel.

Full suspension burning requires a very fine particle size of the combustible material, for example, pulverized coal. This type of burning is used primarily because of a very rapid response in the rate of heat production. This responsiveness is required where it is desirable to be able to match heat production to the steam demands of a boiler. However, full suspension burning creates a large fraction of fly ash which must be removed from the flue gas stream.

Semi-suspension burning is utilized for intermediate size solid fuels, generally with dimensions of one to two inches. The combustible material is thrown or blown into the flame zone, where combustion is initiated. Completion of the burning process takes place on a grate. This type of combustion is used in many coal-fired power plants, and has been used with processed municipal wastes (Refuse-Derived Fuel, RDF) serving as an auxiliary fuel to coal in a number of installations. This process provides reasonably rapid response to changes in steam demands and produces less fly ash than full suspension burning.

In mass burning of large size materials, the solid fuel is added directly to the bed of fuel on the grate. This type of burning is used in virtually all incinerators disposing unprocessed municipal solid waste and produces less fly ash than either of the above methods.

Regardless of the method of burning, the process of combustion of a solid material involves several distinct steps. These include oxidation, reduction, pyrolysis and drying. Consideration of a simple vertical section through a burning bed of solid fuel will aid in developing the process of combustion. The assumption is made that the burning process is in a steady state. Air is admitted upward through the bottom of the bed. At the lowest level is a region of burned out ash through which the incoming air is forced. Immediately above the ash, carbonaceous char is being oxidized to carbon dioxide in the presence of an excess of oxygen. Moving upwards, the free oxygen is consumed, and the hot carbon dioxide from below is reduced by the carbonaceous char to carbon monoxide. This reaction requires the input of heat, which is derived from the gas flow; the temperature of the gas flow is lessened by the heat extracted to drive the reduction reaction. Higher in the bed, the temperature of the gas flow is reduced to the point that the reduction reaction stops, but the gas is still hot enough to pyrolyze organic compounds in the fuel and drive off volatile compounds. These processes also require the input of heat, so the temperature of the gas flow is reduced still further. Near the top of the bed of solid materials, the heat from the gases dries the fuel by driving off moisture. Carbon dioxide and volatilized gases escape from the upper surface of the bed, are mixed with additional air, and are oxidized in flaming combustion. In the entire process,

only char oxidation near the bottom of the bed and flaming combustion above the bed produce heat. Carbon dioxide reduction, pyrolysis, and drying absorb heat and reduce the temperature of the gas flow.

For a particular piece of fuel, the combustion process may not proceed as smoothly and continuously as outlined above. Agitation of the bed or variations in local air flow due to shifting of the bed may change the environment of a given piece of fuel from an oxidizing to a reducing condition and back again quite rapidly.

Implementation of the combustion process is dependent on the nature of the fuel and the results desired from combustion. The entire combustion process may take place in the same general volume (one-step combustion) as described above. One-step combustion is found in mass-fired incinerators for municipal solid waste disposal, in boilers co-fired with coal and prepared waste (RDF), and in more specialized types of incinerators such as rotary kiln, multiple hearth and fluidized bed types. In one-step combustion, an excess of air (usually 50 to 100 percent greater than required for complete combustion) is introduced into the chamber in order to assure relatively complete combustion.

Two-step combustion is appropriate when it is necessary to minimize the particulate loading in the flue gas or to control the combustion temperature for fuels with very high heat content. Two-step combustion also permits the production of fuel gas for extraction and use at other locations. Two-step incineration systems include multiple chamber or controlled air incinerators and pyrolyzers or gasifiers for fuel gas production. Limitation of the amount of air permitted in the solid fuel combustion chamber to 40 to 50 percent of that required for complete combustion precludes the flaming combustion of the gases above the bed. Additional air is then supplied at the point at which these gases are ultimately burned.

In both one- and two-step combustion, the solid fuel undergoes the same combustion steps (oxidation, reduction, pyrolysis, drying). In the context of carbon fiber composites entering incineration, the combustion of the composite material will be very similar in either process. The destruction of the matrix material will likely occur in the pyrolysis or charring region; in this region, there is neither sufficient temperature nor oxidizing gas to consume the carbon fiber itself. These considerations will be applied to each of the oxidation techniques contained within the general context of one-step combustion, two-step combustion and other oxidizing techniques.

6.4.2 ONE-STEP COMBUSTION INCINERATIONS

One-step combustion processes include such installations as mass-fired incinerators, refuse-derived fuel system (RDF), grateless incinerators and fluidized bed incinerators. Of these techniques, mass-firing and RDF may be considered as well developed; grateless and fluidized bed incinerators tend to have specialized applications and are considered a technique still in need of extensive development for effective applications to municipal waste streams.

Mass-fired Incinerators.

Virtually all incinerators presently disposing of unprocessed municipal solid waste are of the mass-fired type. These units burn solid waste in a bed one to two feet deep on a grate which allows the upward flow of combustion air through the bed. Figure 6-2 illustrates a typical conventional incinerator of this type. The grates upon which the bed of burning materials rests are inclined downward from the feed end to the ash discharge end. Some mechanical means, usually a reciprocating mechanism attached to the grate, moves the bed material toward the discharge. Alternating horizontal steps or vertical "staircase" sections of the grate slowly move back and forth; each cycle advances the bed material to the next lower step. Usually, some means of turning the bed material over to assure good burn-out is included. In some cases, this is accomplished by a drop of above 1½ to 3 feet from one grate to the next. In reverse reciprocating systems, the grate is more steeply inclined and the reciprocating action pushes upward under the bed material, tumbling it onto the next grate step. At the discharge, the residual ash drops into a quench bath. The time required for passage of material from the entry grate to the quench system varies with size of the installation and operating conditions; twenty to forty-five minutes are typical passage times.

Mass-fired one-step incinerators usually use about 50 to 100 percent more combustion air than required for complete combustion of the waste. About 75 to 80 percent of this air is supplied as underfire air, blown upward through apertures in the grate structure. The remainder of the combustion air is supplied through high velocity overfire air jets above the bed. This ensures good mixing and complete combustion of the gases.

The average velocity of the underfire air through the bed, assuming 10 percent open area through the bed

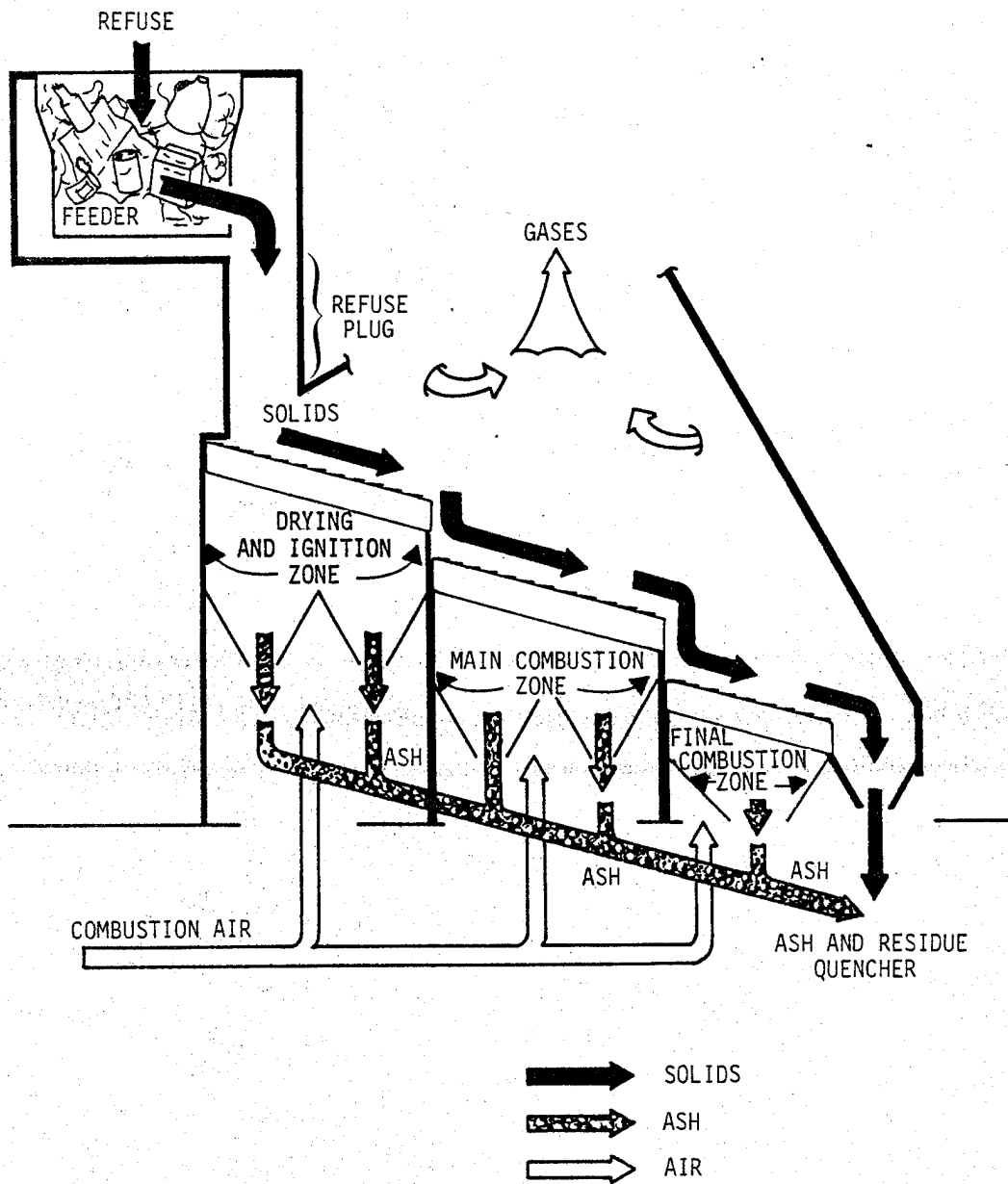

Figure 6-2. Conventional Mass-Fired Incinerator

and an average temperature in the bed of about 550° C, is on the order of 15 meters per second. Velocities in the airstream above the bed will be much less than this value. The velocity of the air as it enters the bed through the grate apertures is about 40 meters per second. Comparing these air velocities with the composite material fiber release test data previously cited, it appears that as much as 1 to 2 percent of the carbon fibers originally in the composite could be released as single fibers more than 1 mm in length. Two aspects of one-step mass-fired incineration have not been quantified. The effect of bed thickness on fiber release has not been defined; the existing release data is based on a bed thickness which is essentially zero. Also, the extent of break-up or fracturing of fibers upon impact with bed material or the walls of the chamber has not been determined; some data indicates that in airflows above about 30 meters per second, such fiber break-up can occur.

In order to evaluate whether a carbon fiber released from the composite matrix could be completely oxidized before leaving the incinerator, estimates of dwell time, temperature and available oxygen have been made using design information from the Chicago Northwest Incinerator. The free oxygen in the furnace combustion gases ranges from about 7 to 11 percent. A fiber leaving the upper surface of the bed would traverse the flame zone in about one second; in a maximum of about 4 seconds, the gas temperature will be less than 900° C. Data previously cited indicates that at these oxygen concentrations, 175 to 230 seconds exposure at 1,000° C would be required for oxidation of 60 percent of the fiber's weight. Many of the fibers will be oxidized along with the matrix material in the bed, but those fibers which escape as the matrix material burns away will have only a very brief exposure to conditions which would oxidize them. It is concluded, therefore, that the conditions of oxidation above the burning bed are not sufficient to ensure oxidation of escaping fibers.

Although most incinerators of this type are equipped with electrostatic precipitators for control of particulate emissions, their effectiveness in removal of single carbon fibers from the flue gas is undefined. Some carbon fibers may be contained in the collected fly ash, as well as in the grate residue from the combustion chamber. In both cases, these materials are water quenched and transported wet to a disposal site. No significant escape of airborne fibers from the wet ash is anticipated.

Refuse-Derived Fuel (RDF) Co-Fired with Coal.

The development of the technology for utilizing a portion of municipal waste as a fuel has been spurred by the increased cost of fuels and reduced availability of landfill or other disposal methods. In this application, solid waste is processed to reduce particle size and separate non-combustible materials. In the separation process, carbon fiber composite material may become a portion of the combustible fraction. This fraction is fired together with coal (~20% RDF/80% coal) in boilers designed for use of coal as the fuel.

The Ames, Iowa operation may be taken as a typical application of this type. Incoming municipal waste is passed through two stages of hammermill shredding in order to reduce particle sizes to less than about 1½ inches. Density separation in an upward air flow classifier follows; heavy fractions (glass, metal) are separated, and the light fraction (potentially containing carbon fiber composite material) is used as a fuel.

At Ames, the RDF is co-fired with coal in two different types of boilers. One boiler uses pulverized coal pneumatically injected into the furnace through four tangential burners. The RDF is blown into the furnace immediately below the plane of the coal injectors. Light pieces of refuse are carried up through the burning coal and heavier pieces fall onto a dump grate where they continue to burn. Periodically, the grate dumps the accumulated ash into a water quench where it is sluiced out for disposal. The unit is equipped with an electrostatic precipitator to remove the fine fly ash resulting from burning the pulverized coal. Originally, the RDF was blown into the furnace immediately above the coal injection, but problems were observed with incompletely burned paper and leaves in the flue gas stream. Relocation of the RDF injection point below the coal injection alleviated this problem.

The second type of boiler at Ames is a semi-suspension coal burner in which the spreader stoker throws the coal into the furnace. The RDF is blown into the furnace above the coal stoker. Both coal and refuse undergo partial burning while falling through the flame zone onto the grate, where burning is completed. The grate moves slowly, like an endless belt. Ash is dropped into a removal system. The boiler is equipped with mechanical (inertial) fly ash

collectors in which a 180° change in airflow direction is used to separate the relatively massive particles typical of coal fly ash from the flue gas stream. Inertial fly ash collectors are not very effective in removing fine particulates resulting from waste combustion.

The potential for release of free fibers from carbon fiber composite material contained in the refuse fuel fed to the boilers would be similar to that for mass-fired, one-step incinerators. For electrostatic precipitators, data from field testing would be useful in quantifying the effectiveness of these devices in removing carbon fibers from the flue gas stream.

Grateless Incinerators.

Grateless incinerators are used primarily for the incineration of wet sludges and do not show any specific advantage for use in incineration of carbon fiber composites. However, if carbon fiber material is present in the sludge, it may enter into this type of incineration process.

Grateless incinerators are of two types: rotary kiln and multiple hearth. Functionally, in both types waste is moved along a solid refractory surface from the feed end to the ash discharge end. No grates are used to permit air to be introduced through the waste bed. Mechanical agitation of the material is used to achieve air/fuel contact.

Multiple hearth units (Figure 6-3) use a stack of circular hearths. The hearths are alternately ones with central holes and ones with clearance at the periphery. In each hearth, rotating rakes stir the waste and move it either to the center or the edge, where it drops to the next lower hearth.

Rotary kilns are slightly inclined downward toward the discharge end. Waste enters at the top and rotation of the kiln causes it to move downward and supplies the agitation necessary for air/fuel contact.

Fluidized Bed Incinerators.

This type of incinerator (Figure 6-4) makes use of a fluidized bed of non-combustible material (sand or similar particles) kept in suspension by a sufficiently high flow rate of air upward through the bed. The particles are maintained in a constant state of

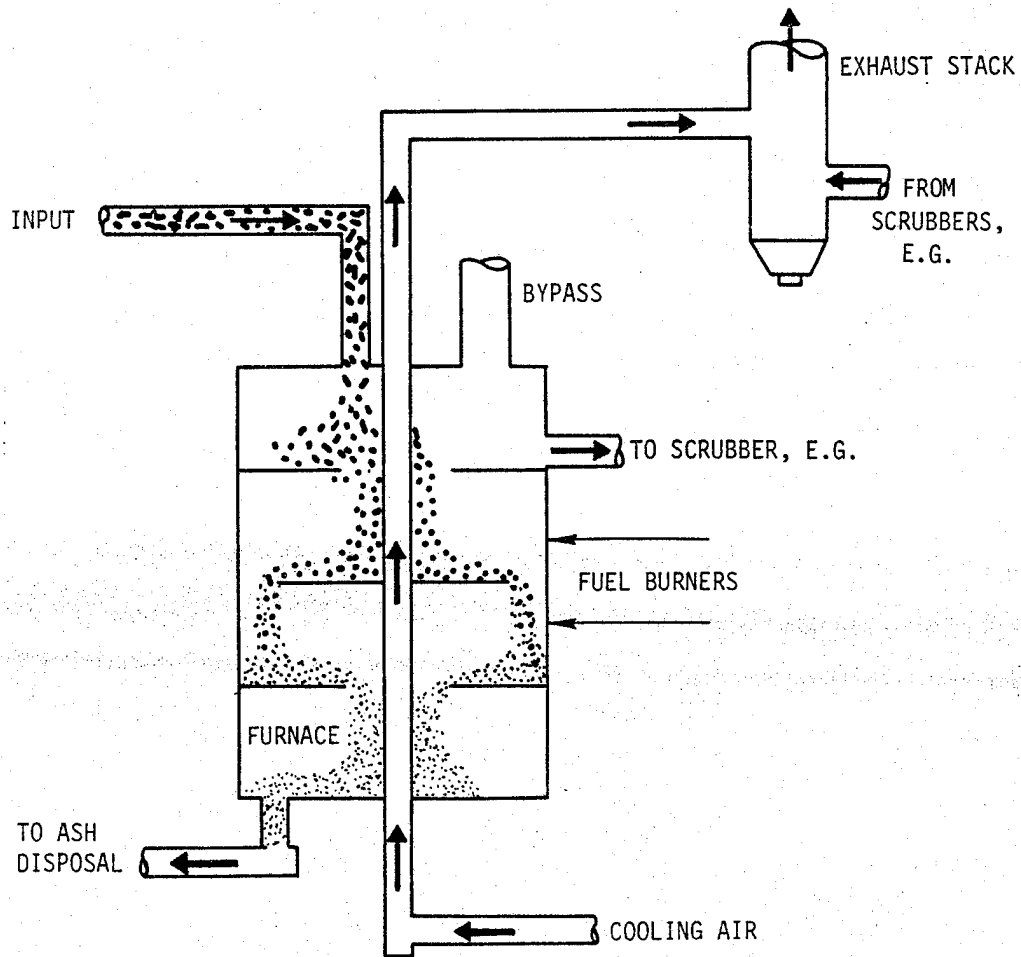

Figure 6-3. Multiple-Hearth Incinerator.

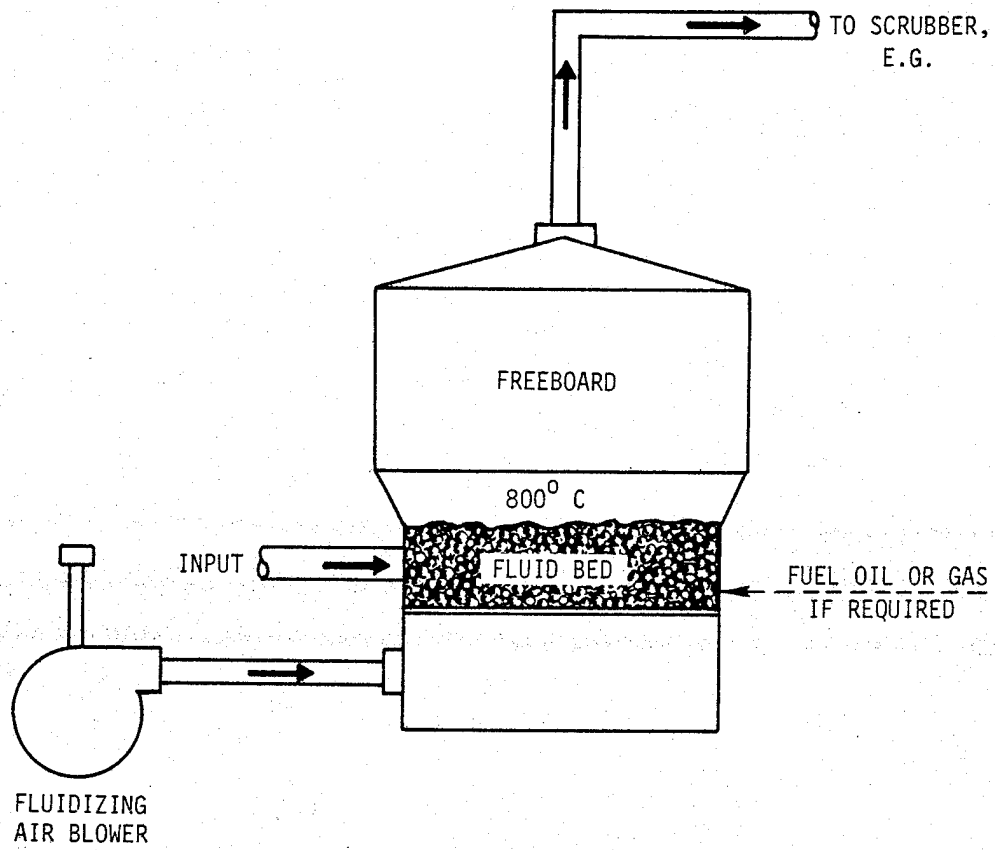

Figure 6-4. Fluid Bed Incinerator.

motion and behave as if they were a fluid. The bed material is initially heated to a temperature of about 800° C by means of a liquid or gaseous fuel injected at the bottom of the bed along with the fluidizing air. The bed provides a medium for igniting and carrying on the burning of any combustible material introduced into the bed. The material of the bed provides a large heat sink which is well suited for use with wet sludge. The heat contained in the bed material allows drying of the fuel without interfering with the combustion process. Agitation of the bed by the fluidizing air ensures good mixing of the air with the combustible materials. The heat of combustion maintains the temperature of the bed material in addition to being transmitted to the combustion gases. Most of the combustion occurs within the bed itself; very little burning takes place in the freeboard area above the bed. Combustion temperatures remain relatively low, as the bed averages out the heat sources and sinks of the various stages of the combustion process. Some demonstration work has been done using this process for incinerating municipal solid wastes, but there are no municipal units in operation at present.

The use of fluidized bed incinerators for the disposal of carbon fibers involves several factors which may affect the amount of free carbon fiber release into the flue gases. The high degree of agitation and airflow within the bed would be conducive to the release of free carbon fiber from the matrix materials. However, interactions with each other and the bed particles would promote fiber break-up and fragmentation. A residence time of the fibers within the 800° C bed on the order of ten seconds would be required to completely oxidize the fibers. It is likely that some oxidation of the fibers would take place within the bed, but that complete destruction of the free fibers would not be assured. Fluidized bed incineration of carbon fiber composites does not appear to be effective in limiting the release of airborne carbon fibers. The use of this method for generalized municipal solid waste disposal does not appear to be cost-effective.

6.4.3 TWO-STEP COMBUSTION INCINERATORS

The two basic types of two-step combustion incinerators are controlled air incinerators and gasifiers. Both types are mass-fired. The division is dependent on the end use intended for the volatilized combustion gases. In the uncontrolled air (or multiple chamber) incinerator, the gases are burned in a second

chamber, in close proximity to the burning waste bed. Where the volatilized gas is intended for use as a fuel at a remote location, a gasifier (pyrolysis system) is used.

Controlled Air.

The primary reason for using a controlled air incinerator is to reduce the amount of particulate matter in the flue gas by minimizing agitation and turbulence at the burning solid waste bed. A minimum underfire air flow (about 40 percent of that required for complete combustion) is introduced through the burning bed; no overfire air is introduced into the chamber above the bed. The remaining air for complete combustion is added to the combustible gases in an afterburner chamber. The afterburner chamber is frequently equipped with an auxiliary fuel burner to maintain proper combustion conditions for complete combustion during start-up and shut-down stages.

The solid waste may be burned on fixed grates for a batch type incinerator. In continuous feed systems, waste is burned on a travelling grate or advanced along fixed grate sections by a ram. Due to the reduction of underfire air, air velocity through the bed is estimated to be about 1/4 to 1/3 of that in the one-step combustion process, or on the order of 4 to 5 meters per second. Comparison with fiber release tests in which there was little mechanical agitation indicates that as much as 0.25 percent of the fibers in the composite might be expected to be released as single fibers greater than 1 mm in length. Since the combustion air in the chamber where the solid waste is burned is limited, no oxidation of a released fiber would be expected to occur in that chamber. The duration of exposure of the fiber to flame temperature in the afterburner is estimated to be about one second; total time above 900° C would probably be no more than 2 to 4 seconds. This time/temperature exposure would not be sufficient to assure destruction of any released fibers. Normally, there is no particulate removal treatment of the flue gas from the after burner; one of the reasons for using this system is that such treatment is made unnecessary. This type of incineration is also useful for the incineration of wastes with very high heating values, since the heat release in the vicinity of the bed is minimized.

Gasifier.

Another reason for burning solid waste with limited air is the production of a fuel gas which can be used

at a point remote from the place where the solid waste is being incinerated. Several processes have been investigated on the pilot plant or demonstration scale using municipal solid wastes, but none are in operation at this time.

The design of the unit in which the solid waste is reacted varies with the particular process; several have used vertical kilns in which a tall column of waste is burned from the bottom, using either oxygen or heated air (about 40 percent of that required for complete combustion) to achieve a sufficiently high temperature to melt the residue to a liquid slag which drains into a water quench pit. The gas velocity for a kiln of this type using heated air is calculated to be on the order of 27 meters per second (assumes 10 percent free area through the waste bed). This velocity is roughly equal to that at which fiber break-up and fragmentation from impact with the walls is initiated. This velocity might be expected to produce about 1 percent free carbon fibers from the composite. Any unburned fibers remaining in the residue of a process like this would be incorporated into the slag and are unlikely to be released at a later time.

Another system (pyrolyzer) uses an indirectly heated kiln to pyrolyze the waste. Heat is supplied by burning the residual char or supplementary fuel; the resulting heat is used to drive the pyrolysis. This method has minimum gas velocities in the pyrolyzer; very few fibers are likely to be released in that unit. The subsequent burning of the char, however, could potentially result in fiber release.

6.4.4 OTHER OXIDATION TECHNIQUES

Three other oxidation techniques have been developed to the pilot plant level. These techniques have been directed primarily toward the disposal of toxic or malodorous wastes; however, they have the potential for adaptation to the disposition of carbon fiber materials. In particular, the techniques discussed here have the capability of destroying carbon fiber materials with little or no prospect of airborne fiber release. In those cases in which the carbon fiber composite is identifiable and controlled (old airplane parts, production scrap, etc.), these techniques offer an alternative to landfill. The technologies of Molten Salt Incineration, Wet Air Oxidation, and Toxic Waste type incineration are candidates for the disposal of carbon fiber composite materials.

These techniques have limitations on the size of the particles fed into the reaction zone. They also require a means for injection of such particles. Therefore, the use of one of these techniques for the disposal of carbon fiber composite material would require the interrelated development of a specific method for controlling the size of the input material and a method for injecting the material into the reaction zone. The three techniques appear to have different requirements which may limit cross-sharing of developments. The specific size control and feed systems would be tailored to the particular disposal technique. Consequently, the choice of one of these techniques for disposal of carbon fiber materials implies a degree of dedication of that system for the specific handling of composites.

Molten Salt Incineration.

Molten salt baths have a long history in the metal industry, where they have been used for heat treating. The salt bath can maintain a relatively high, controllable temperature; this attribute has been capitalized on in the development of molten salt incinerators. These have been developed to the pilot plant level and have, thus far, concentrated on the disposal of organic compounds. In disposal applications, the salt bath is usually composed of 90 percent sodium carbonate and 10 percent sodium sulfate. Additions of small amounts of other salts allow the entrapment of toxic compounds or the control of objectionable constituents. Injection of air into the salt bed provides the oxidizing agent for the combustion of the waste materials. Normal operating temperatures are in the range of 800 to 1,000° C.

Molten salt incineration is effective in controlling the emission of particulate matter because of the wetting of the particles by the salt solutions. The temperatures are sufficient to bring about the destruction of the binder material of a composite, and, because of the wetted carbon fibers will have a long residence time at high temperature, they too will be destroyed. The controlled inclusion in the bath of a salt which could serve as a supplemental oxidizing agent (NaNO_3 , KNO_3 , e.g.) would speed the destruction of the composite material.

The salt bath eventually becomes contaminated and is disposed of by landfill. However, carbon fiber composites are not expected to lead to rapid contamination of the salts, and the volume of materials incinerated by this technique would be much greater than the volume of the salt placed in landfill.

At present, the economics of molten salt incineration appears to preclude its use for generalized disposal of carbon fiber composites. On the other hand, this technique appears capable of effectively handling uncoated fibers, and uncured, overaged or scrap prepreg.

Wet Air Oxidation.

The wet air oxidation (WAO) process (Figure 6-5) capitalizes on the increased rate of oxidation of combustible materials which can be achieved by subjecting them to high pressures, typically 7 to 21 MPa (1,000 - 3,000 psi). These pressures increase the partial pressure of oxygen by two orders of magnitude, and complete oxidation of aqueous organic waste materials takes place at temperatures of 170° to 350° C. At temperatures around 200° C, dissolved or suspended combustible materials begin to oxidize and generate heat (and potentially steam). The measurements to date indicate combustion efficiencies approaching 85 percent for heat addition to the water. The limitation to the reaction coincides with the critical point for water at 374° C (705° F) and 22.4 MPa (3,200 psi).

The operating conditions of a WAO unit are not sufficient to break down particularly stubborn chemical bonds such as those in halogenated organics, for example. However, WAO temperatures and pressures will effectively oxidize the organic polymers which make up the binders in composites. Thus far, the ability of wet air oxidation to combust graphitized fibers has not been determined, although the oxidation of pulverized coal slurries has been well established.

WAO is being investigated in a wide range of experimental applications, including regeneration of activated carbon, desulfurization of coal slurries and dewatering of peat for the production of fuel. The process is being used commercially for bleaching of pulp for paper production and recovery of pulping liquor constituents. Worldwide, more than 100 WAO units are being used for the oxidation of sewage sludge, frequently in "pristine" areas with stringent air quality standards. As a disposal process, wet air oxidation offers the advantage of no emissions to the atmosphere other than water vapor, carbon dioxide and nitrogen. The application of WAO to the disposal of carbon fiber composite material will require a demonstration of its suitability prior to initiation of a program for the development of a WAO as a disposal technique for composites.

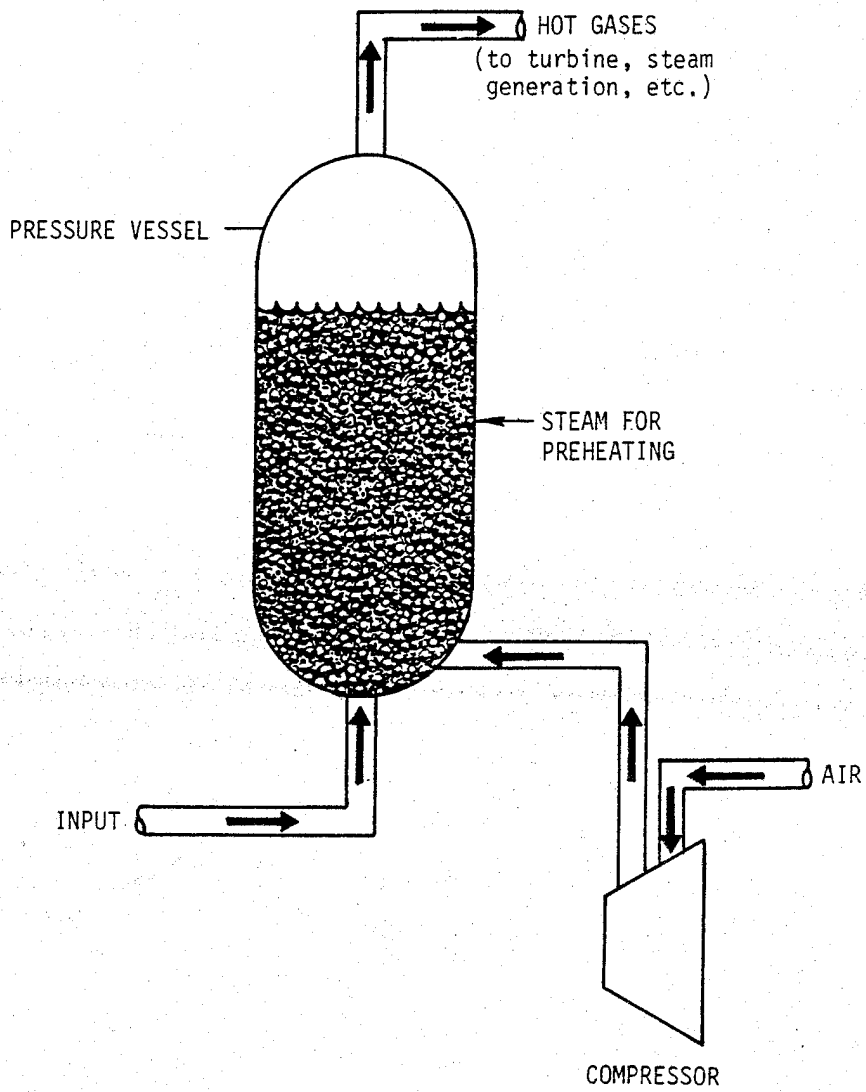

Figure 6-5. Wet Air Oxidation.

Ultra-high Temperature Toxic Waste Incinerators.

The development of incinerators designed for the destruction of toxic wastes (particularly halogenated organics) provides a potential method for the disposal of carbon fibers. In order to destroy stubborn organic compounds, abundant oxygen and auxiliary fuels are used to achieve flame temperatures on the order of 1,300° C and stack temperatures of 1,200° C. At these temperatures, carbon fibers will oxidize in less than one second, making these incinerators candidates for disposal of controlled carbon fiber scrap. An ultra-high temperature incinerator is being used by Shell Chemical Company for incineration of chlorinated wastes. The unit is mounted on a ship, and burning takes place on the high seas in accordance with international agreements. Such ship-mounted incineration of segregated carbon fiber materials would probably be environmentally acceptable, but not cost effective. The development of land-based ultra-high temperature toxic waste incinerators, now under way, offers the potential for a more cost-effective method for disposal of these materials.

6.5 RESULTS

6.5.1 SUMMARY OF RESULTS

The candidate techniques for disposal of carbon fiber composite materials fall into three general categories based on current operational status, since the present waste stream probably contains small amounts of composites. The first category contains the four techniques presently in place and processing municipal waste streams: these include landfill; one-step mass-fired burning; refuse-derived fuel; and two-step mass-fired (controlled air) burning. In general, these techniques can accept carbon fiber materials, provided that confirmatory measurements show containment of released fibers or if individual systems are adjusted to eliminate the release of airborne carbon fiber. The pertinent results for these techniques are summarized in Table 6-2 and are discussed in paragraph 6.5.2 below.

The second category consists of three techniques which have some potential for application to municipal waste streams, but are not now in general use. These include gasifiers for fuel generation; fluidized beds; and multiple hearth or rotary kiln incinerators. Since none of these units are presently processing municipal waste, they do not appear to justify any immediate action. Table 6-3 summarizes the evaluations of these techniques. They are discussed in paragraph 6.5.3 below.

TABLE 6-2. RESULTS OF EVALUATION FOR IN-PLACE MUNICIPAL DISPOSAL TECHNIQUES

DISPOSAL TECHNIQUE	FORMS OF CARBON FIBER SCRAP ACCEPTED	PRE-PROCESSING REQUIRED	POTENTIAL FOR FIBER OXIDATION	ESTIMATED MAXIMUM RELEASE PERCENT	DOWNSTREAM PARTICLE CONTROL	RECOMMENDED ACTION
1. Landfill						
a. Bulk	Tow Prepreg Cured Composite	None	None	None	N/A	No action, use as is.
b. Crushed or compacted	Tow Prepreg Cured Composite	Crush or compact	None	None	N/A	Verify that crusher or compactor operates without causing release of fibers.
2. Mass-burning Single Step	Tow Prepreg Cured Composite	None	Good	1	Requires precipitators, scrubber or baghouse.	Measure efficiencies of particulate controls, in particular electrostatic precipitators with carbon fibers mixed with other particles.
3. Refuse-Derived Fuel	Cured Composite only	Shredding Screening Classifying	Good	2	Requires precipitators, scrubber or baghouse.	o Verify that processing steps do not generate free airborne fibers. o Measure efficiencies of particulate controls systems in handling carbon fibers mixed with other combustion particulates.
4. Mass-fired Two-step burn	Cured Composite only	None	Good	0.5	None used in these units.	o Experimentally evaluate comparability of these incinerators with oxidation of composites. o Define operating parameters for acceptable oxidation of composite materials.

The third category includes three techniques which have been developed to pilot scale operation for specialized disposals. They are: Toxic Waste Incinerators; Molten Salt Incinerators; and Wet Air Oxidation System. These techniques have the potential for complete destruction of carbon fibers and composites, but require a certain degree of dedication of the facility for that purpose. Should further study define a need for complete destruction of carbon fiber, the use of dedicated or semi-dedicated facilities utilizing these techniques should be investigated. Evaluations of these techniques are summarized in Table 6-4. The assessments are developed in more detail in paragraph 6.5.4 below.

6.5.2 IN-PLACE, OPERATING MUNICIPAL DISPOSAL TECHNIQUES

In consideration of the present production rates for sporting goods, all municipal waste streams must assume the presence of some small quantity of cured carbon fiber composites. The effects from the present quantities are not considered detectable. Because of the expected increased use of carbon fiber composites in automotive, industrial and other applications, either an assurance of the compatibility of these techniques with carbon fiber disposal or a definition of the effort required to achieve compatibility is required. These requirements are described for each of the four disposal techniques in current municipal service. The order of presentation reflects an estimate of the relative effort required to allow use of the technique for carbon fiber disposal.

Landfill

Landfill of bulk materials, either as production scrap or discarded composite, stands as the only technique currently in place and available, without need for further action. Present projections do not foresee any materials, fabrication technologies, or end products which will not be compatible with bulk disposal by landfill. On-site operations which compact the dumped mix of materials by rolling or tamping should not generate any airborne fibers. On the other hand, crushing or compaction operations prior to dumping need to be measured in order to assure airborne carbon fibers are not generated.

The only expressed concern relative to landfill has appeared in the course of disposal of the burned residue from NASA-sponsored fire-release testing. Like diamonds, graphite fibers are forever. Concern has been expressed for releases from future excavation of closed landfills. Although carbon fiber material could be treated as a toxic waste and interred in assured landfills, disposal techniques which completely

destroy these materials appear feasible and are preferable for these residues.

One-Step, Mass-Fired Burning

Mass-burning incinerators with particulate controls in the output stacks appear acceptable for the disposal of carbon fiber scrap when mixed with municipal refuse. The dwell times and temperatures within the fire zone will substantially oxidize the composite. The wet quench of the ashes will contain any fibers in the residue. The fire will release some fibers into the gas stream for capture or control by the particle remover. Such incinerators can be considered acceptable if measurements on the particulate control system show the same efficiency for the removal of fibers as they do for other particulates. Bag house and wet scrubbers have a degree of assurance from previous test experience. The effective operation of electrostatic precipitators needs experimental verification under flow conditions which combine the regular concentration of fly ash and combustion residue with an appropriate quantity of carbon fiber.

Refuse-Derived Fuel (RDF)

The present technology for hammermill shredders limits RDF to processing only cured composites. Uncoated fiber and uncured composites can release airborne fibers when processed through combinations including hammer shredding and air classification or trommel screening. The co-firing of RDF with coal implies a particulate control in the stack gas stream. The use of RDF for disposal of carbon fiber composites requires data which establishes the airborne release of single carbon fibers from RDF facilities. The need for data on the effectiveness of particulate control systems is re-emphasized. Assessments of residues from grinding and sawing of cured composites indicate that the pre-injection preparation of RDF may generate a quantity of fine residue in the form of dust and splinters.

Two-step, Mass-Fired (Controlled Air) Burning

This technique appears to present the greatest uncertainty in assessing its capability to dispose of carbon fiber composites without releasing airborne carbon fibers. The primary burn proceeds with a minimum of agitation, and accordingly, should produce few airborne fibers. The temperature of the second burn is high enough to burn the released fibers, but

the transit times are too short for complete oxidation. Since these incinerators operate without particulate controls in their stacks, some release of partially oxidized fibers must be expected. Adjustments in feed rate, temperature and/or air supplies may offer a means for achieving complete oxidation of fiber, either before release or during the second burn. Establishment of operating conditions compatible with the disposal of carbon fiber composites will require experimental measurements from units operating with composite in the waste stream. The data must show a stable combustion regime which produces no emissions of fibers. The regime should be defined in terms of controllable operating parameters, such as feed rate and air flow. The uncertainties associated with this type of an incinerator justifies an experimental evaluation. However, at present, this type of incinerator does not appear to offer any means for achieving compatibility with carbon fiber materials which release fibers readily, such as production scrap containing unbonded fibers or uncured resins.

6.5.3 TECHNIQUES WITH POTENTIAL APPLICATION TO MUNICIPAL WASTE STREAMS

The techniques discussed below comprise three approaches to incineration which have been considered for application to municipal waste streams; at present, there are no major operating facilities using these techniques for disposal of municipal waste. Gasifiers, Fluidized Bed Incinerators, and Grateless Incinerators permit tailoring to specific types of waste; consequently, they can be designed for operation over a wide temperature range. When incinerators of this type are designed for handling municipal wastes, it may be desirable to verify each installation for its compatibility with the disposal of carbon fiber composites. Immediate action appears neither necessary nor justified unless related to a particular installation. Data from operating experiences and developments in these techniques should be reviewed for compatibility with the disposal of carbon fibers. A future decision to proceed with a major installation for municipal applications would justify an in-depth review of the proposed system for such compatibility. The general considerations for each technique have been summarized in Table 6-3, and are discussed below.

Gasifiers for Fuel Gas Generation

Two techniques are used for the production of fuel gas from municipal wastes, both involving a long dwell time at oxidizing temperatures, but at low oxygen concentrations. One type of gasifier uses a tall

TABLE 6-3. RESULTS OF EVALUATION FOR TECHNIQUES WITH POTENTIAL FOR APPLICATION TO MUNICIPAL WASTE STREAMS

DISPOSAL TECHNIQUE	FORMS OF CARBON FIBER SCRAP ACCEPTED	PRE-PROCESSING REQUIRED	POTENTIAL FOR FIBER OXIDATION	ESTIMATED MAXIMUM RELEASE PERCENT	DOWNSTREAM PARTICLE CONTROL	RECOMMENDED ACTION
1. Gasifier for Fuel Gas Generation	Tow Prepreg Cured Composite	None	Good	1	Requires precipitator or scrubber	No immediate action required for any of these techniques. Proposed units will need verification that particle control system removes carbon fibers.
2. Fluidized Bed	Cured Composite	Shredding Classification	Fair	3	Requires precipitator, scrubber or baghouse	Proposed units would need verification of control over carbon fiber during processing steps and in the gas stream.
3. Grateless						
a. Multiple hearth	Cured Composite	None	Fair	2	Requires precipitator, scrubber or baghouse	Proposed units would require verification that particle control system removes carbon fibers.
b. Rotary kiln	Cured composite	None	Fair	3		

column of waste burned from the bottom; the mass of material above the burning zone may act as a filter and limit the release of free fibers. The pyrolyzer system uses an indirectly heated kiln and reduced air flow; again, release of free fibers may be limited in the process. In either case, some amount of free fiber, as well as other particulate matter, may be contained in the end product fuel gas. It would be advisable to remove these constituents at the production facility. Otherwise, when the fuel gas is burned at a location remote from the gasifier, appropriate particulate control (scrubbers, precipitators, etc.) will be necessary for removal of free fibers which remain after the combustion of the gas. In the event that gasifiers are reintroduced into U.S. municipal waste processing, verification will be required that the end user of the fuel gas has undertaken appropriate measures to limit or eliminate the emission of airborne carbon fibers.

Fluidized Bed Incinerators

The disposal of carbon fiber materials through the action of a fluidized bed implies two conditions. First, the carbon fiber scrap must be reduced to a size compatible with the operation of the bed. This preprocessing will involve shredding and classification; therefore, only cured composite should be considered in such a waste stream. The second condition of importance is the inherent agitation of the bed. This will almost assure the release of airborne fibers from chopped and shredded composites. The action of the bed may also facilitate the release of other particulate materials into the gas stream. Therefore, these incinerators would require some particulate control method in the exhaust. In the event a fluidized bed incinerator is used for disposal of a municipal waste stream, measurements verifying control of released fibers would be needed for both the shredding/classification process and the exhaust stream particulate control system.

Grateless Incinerators: Multiple Hearth and Rotary Kiln

These types of incinerators allow the widest range of operating temperatures. Grateless incinerators have been used primarily for incineration of sludges and other wet materials, and show few, if any, advantages for disposal of municipal refuse. Existing refractory linings will permit gas stream temperatures sufficient to oxidize airborne carbon fibers; however,

an incinerator fed by a municipal waste stream would have clinker and/or ash formation problems which could limit temperatures to a marginal condition for oxidation of composite materials. The continuous agitation of a multiple hearth or a rotary kiln would tend to facilitate the release of both airborne fibers and fly ash constituents. The use of grateless incinerators for municipal wastes requires a particle control system in the exhaust. Therefore, the decision to utilize a grateless incinerator would require assurance that the particle control system was capable of removing airborne carbon fibers from the exhaust gas streams.

6.5.4 SPECIAL PURPOSE DISPOSAL TECHNIQUES

The development of disposal techniques for toxic wastes, particularly halogenated and other strongly bonded organic compounds, offers a means for complete oxidation of all forms of carbon fiber scrap. The present emphasis on controls of toxic materials will eventually lead to a number of toxic waste disposal facilities within the United States. Each of these three techniques (Toxic Waste Incineration, Molten Salt Incineration, and Wet Air Oxidation) are candidates for such applications. The anticipated expansion of the use of carbon fiber materials implies extensive development efforts; these projects are likely to produce a large amount of scrap in varying degrees of lay up, impregnation and cure. In addition, methods for the disposal of outdated or scrapped tow and prepreg material may be required. Quantitative or qualitative limitations on landfill may limit the number of locations which will accept such production scrap. These considerations appear to justify a further effort for assessing the need for and desirability of a system which can be used for the disposal of carbon fiber production scrap. The facilities may be either a small scale, full-time (dedicated) operation; or a large scale, part-time (semi-dedicated) one. The pertinent results for these techniques are summarized in Table 6-4. The assessment of suitability for each technique is described below.

Toxic Waste Incinerators

The literature describes an ultra-high temperature toxic waste incinerator presently operating aboard a ship. Within the next decade, a number of land-based units of this type are likely to be brought into operation. In addition to having an extremely high temperature zone capable of consuming airborne carbon fibers, these facilities will have the additional advantages of sophisticated operating teams and remote locations. The technical teams which will design, develop and operate these incinerators should be

TABLE 6-4. RESULTS OF EVALUATION FOR SPECIAL PURPOSE DISPOSAL TECHNIQUES

DISPOSAL TECHNIQUE	FORMS OF CARBON FIBER SCRAP ACCEPTED	PRE-PROCESSING REQUIRED	POTENTIAL FOR FIBER OXIDATION	ESTIMATED MAXIMUM RELEASE PERCENT	DOWNSTREAM PARTICLE CONTROL	RECOMMENDED ACTION
1. Toxic Waste	Tow Prepreg Cured Composite	Chop	Excellent	Can be zero	None needed	A review of need for disposal facilities dedicated to carbon fiber scrap should precede any other action.
2. Molten Salt	Tow Prepreg Cured Composite	Chop	Excellent	Contained in salt bath	None	Review for complexity in processor and injector. Review for adequate rate of disposal.
3. Wet Air Oxidation	Tow Prepreg Cured Composite	Chop (wet)	Excellent (if verified)	Contained in reactor	None	Requires verification that graphitic structure of the fiber will oxidize in reactor.

capable of adapting such an incinerator to the disposal of carbon fiber. Modification of a toxic waste incinerator to handle carbon fibers offers the method with the greatest assurance for achieving such a capability within the United States.

Molten Salt Incinerators

Molten Salt Incinerators will exist, but not in the same numbers or with the same capacities as Toxic Waste Units. Where they exist, they will have knowledgeable designers and operators. This, coupled with a greater tolerance on the size of the feed materials, suggests that these units may represent an option when only a small amount of carbon fiber material needs total destruction.

Wet Air Oxidation

Wet Air Oxidation appears to be in active development for a wide range of applications. The use of WAO in the conditioning of sludges has generated a base of operating experience. Wet Air Oxidation has been considered as a disposal technique for municipal waste streams. The effectiveness of WAO in oxidizing carbon fibers must be demonstrated. A successful demonstration may result in a large number of installations as potential candidates for disposition of composites and carbon fibers.

Effective WAO requires chopping or grinding as a preprocess step before injection into a reactor. Since the process can be done wet, shredding of carbon fiber would not be expected to generate significant amounts of airborne carbon fibers.

6.6 RECOMMENDATIONS

6.6.1 IMMEDIATE NEEDS

Analysis of disposal techniques identifies three actions considered as current needs. These relate to the measurements of particle controls, the verification of emission from preprocessing, and the evaluation of mass-fired two-step incinerators.

A. Measurements of Particle Control Systems.

Definitive measurements are needed to characterize the carbon fiber removal efficiencies of electrostatic precipitators, wet scrubbers, and

bag houses. The data should cover a representative configuration for each system. Tests should be conducted on fibers as well as mixtures of fibers and other particulates present in gas streams from incinerators. The relationship between removal efficiency and fiber length should be determined. The EPA owns three mobile pilot scale particle control systems considered representative of current practice. In addition, the EPA has access to a means for preparing carbon fiber samples to any length specification above 0.1 mm. Mass burning incinerators located on Federal facilities include incinerators with electrostatic precipitators which are fed by municipal waste streams. Thus, the EPA has the means to institute an experimental program which can provide the needed measurements and data without impacting any private or municipal operating installations. Verification that existing particulate control technologies limit or eliminate airborne fiber emissions would give assurance that carbon fiber scrap can be safely processed through these existing mass-fired incinerators which operate within EPA-defined limits for particle emissions.

B. Measurements of Emission from Preprocessing Steps.

Definitive measurements are needed to show whether the processing steps of shredding, screening, air classification, crushing and compaction result in the release of uncontrollable airborne fibers. The continuation of the present evaluation of shredding, screening and air classification will provide some elements of the data. The evaluation of existing crushers or compactors should include an assessment of their ability to handle tow, prepreg, and cured composite. Measurements verifying the limiting of airborne emission of carbon fibers from preprocessing would be necessary to assure the applicability of RDF systems and landfill for the disposal of carbon fiber material. The present test program may permit expansion to include the additional operations.

C. Characterization of Mass-Fired, Two-Stage Burn Incinerators.

The level of uncertainty associated with carbon fiber emissions from mass-fired two-stage burn incinerators justifies an experimental evaluation. The evaluation would be best served by use of an offline pilot scale unit, preferably at a research

station; however, access to an experimental unit at a manufacturer's location would be acceptable. The characterization must consider waste content, burn rate, and air flows and their effects on combustion and combustion temperatures. Since there is an uncertainty in the potential for release, these evaluations require the use of effective fiber emission control systems. These tests require use of a particulate control system and should not be carried out until data were available from measurement of particle control systems. The successful completion of a parametric evaluation would define an operating regime achievable for any unit using mass-firing and two-step burning. Evidence of a strong dependence upon the feed mechanism or a limited range of operation may require certification of these units on an individual basis.

6.6.2 FURTHER STUDIES

Present landfills might be excavated at some time in the future; therefore, a concern arises for unexpected releases at that time. Industrial process scrap is a particular concern in this regard. Industrial process scrap will probably represent a significant portion of the total carbon fiber entering disposal facilities over the short term. It is recommended that the EPA make a survey of need and enter into dialogues with the major producers or fabricators toward determining their estimate of needs or desirability for dedicated disposal facilities. The results of the survey would then become the basis for any evaluations and actions relative to developing dedicated or semi-dedicated disposal. The nation may well benefit if each manufacturer of carbon fiber maintained a semi-dedicated disposal facility which served for disposal of both his own production scrap and that returned from the organizations he supplies. Such a system would tend to leave only cured composites to move in any waste stream.

7.0 CARBON FIBER RELEASES INTO THE ENVIRONMENT

7.1 ENVIRONMENTAL CRITERIA AND CONSIDERATIONS

7.1.1 GENERAL

The data presented in this section will be used to make estimates of the potential releases of carbon fibers from municipal incinerators. The present status of the data for carbon fibers requires a series of clarifications and assumptions before utilization in any predictions or projections. These assumptions and clarifications are outlined below.

7.1.2 QUANTITY OF CARBON FIBER COMPOSITES ENTERING MUNICIPAL WASTE STREAMS

At the present time, no obvious large volume source exists for the entry of carbon fiber into municipal waste streams. Eventually, scrapped sporting goods will come into equilibrium with production and the backyard mechanics will provide a source from automotive usage. The data from the Department of Commerce offers a basis for a projection based upon sporting goods and automotive usage. The assumptions are as follows:

- A. 4,500,000 pounds (2.04×10^6 kg) of carbon fiber composites will enter municipal waste streams annually by 1990. This value is equal to the production of sporting goods plus 10 percent of the usage for automobiles.
- B. Carbon fiber composites will enter waste streams at a uniform daily rate with the quantity in proportion to the local population (uniform pounds per person).

7.1.3 LIST OF SYMBOLS

Table 7-1 is a list of symbols used in the development of the estimate of the impact of incineration of carbon fibers and composites. Each symbol is defined, and appropriate units indicated.

TABLE 7-1 LIST OF SYMBOLS

<u>SYMBOL</u>	<u>DEFINITION</u>	<u>UNITS</u>
\bar{L}	Average fiber length	millimeters (10^{-3} meters)
\bar{D}	Average fiber diameter	micrometers (10^{-6} meters)
δ	Density	grams/centimeter ³
F_r	Release fraction; fraction of input fiber mass released as single airborne fibers	dimensionless
N	Specific release; number of fibers released per kilogram of input	fibers/kilogram
V_s	Fall velocity in still air	meters/second
\bar{E}	Exposure, average; average exposure required to cause an electrical failure	fiber-seconds/meter ³
T_f	Transfer function; ratio of fibers transmitted to fibers in ambient air	dimensionless
H_s	Stack Height	meters
V_w	Wind speed	meters/second
R	Fallout radius	meters
A_{50}	50% fallout area; that area in which half of all fiber fallout will occur	meters ²
F_t	Total annual fiber release	fibers/year
E	Exposure, total; total number of fibers, over time, per volume	fiber-seconds/meter ³
C	Concentration of fibers	fibers/meter ³
D	Deposition	fiber/meter ²
P_f	Probability of failure	dimensionless

7.1.4 CONDITIONS OF FIBERS RELEASED FROM INCINERATORS

Data from fire-release testing provide the best available sources for predicting the conditions of carbon fibers released from the hot zones of municipal incinerators. Table 7-2 lists the pertinent parameters of fire-released carbon fibers; test release conditions are assumed to be similar to conditions in municipal incinerators. The table identifies two cases for examination: relatively long fibers as a potential hazard to electrical equipment and partially oxidized, relatively short fibers as a potential health hazard (i.e., respirable fibers).

TABLE 7-2 SUMMARY OF CONDITIONS FOR FIRE-RELEASED CARBON FIBERS

<u>PARAMETER</u>	<u>CONCERN</u>	
	<u>ELECTRICAL</u>	<u>RESPIRABLE</u>
Average Length, \bar{L}	1.7 mm	0.05 mm
Average Diameter, \bar{D}	7 μm	2 μm
Average Fiber Volume ($\frac{1}{4} \bar{D}^2 \pi \bar{L}$)	$6.5 \times 10^{-8} \text{ cm}^3$	$1.57 \times 10^{-10} \text{ cm}^3$
Density, δ	1.7 g/cm ³	1.7 g/cm ³
Number of fibers in 1 Kg	9×10^9	3.7×10^{12}
Release Fraction, F_r	0.01	0.0005
Specific Release, N, (Number of Fibers released from 1 Kg input)	10^8	1.9×10^9
Fall Velocity, V_s , in still air	0.02 m/sec	0.0053 m/sec

7.1.5 INCINERATION IN THE UNITED STATES

The data from operating municipal incinerators and an assessment of the yearly rates for generation of municipal waste permit the following assumptions in estimating the fallout of carbon fibers from stack emissions. The estimates utilize 1990 projections for carbon fiber usage, superimposed upon present municipal waste stream data.

- A. The United States will generate 2×10^8 tons per year of municipal refuse. The value reflects one ton per year generated by each person in a population of 2×10^8 people.
- B. The United States will incinerate 10,450,000 tons of municipal waste in 54 known facilities. This is based on a combined capacity of 29,858 tons per day and 350 days of operation per year. (Reference: Dr. R. J. Alvarez, Solid Waste Management, Nov., 1978.)
- C. Municipal incinerators have prevailing winds such that, averaged over a year, the downwind plume will lay within one quadrant 50% of the time. (One-fourth of the surrounding area sees half of the fallout from a plume.)
- D. Carbon fiber composites will comprise 1.15×10^{-3} per cent of the weight moving in municipal waste streams.
- E. The 54 incinerators cited dispose of 5.2% of the total U.S. waste stream. Thus, the estimate of the total annual amount of carbon fiber composites entering incinerators becomes 2.34×10^5 pounds (1.06×10^5 kg.)

7.1.6 DEMOGRAPHIC DATA

The following values for density of population, numbers of electrical items, and transfer functions are the same as used in calculations for the NASA Risk Assessment and reflect averages based on Bureau of Census data.

- A. Cities have an average population density of 1,000 persons per km^2 .
- B. Households average five electrical items per person. The average exposure, \bar{E} , to cause an electrical failure is 10^7 fiber-seconds/meter³.
- C. The average transfer function, T_f , for airborne fibers entering a building where they can cause an electrical failure is 0.1, that is, 10 percent of the fibers in the ambient air will enter the building.

7.1.7 SIMPLIFIED PLUME DISPERSION MODEL

The simplified plume dispersion model utilizes the following assumptions and calculations:

- A. The 54 incinerators can be described in terms of an average installation with a stack height, H_s , of 200 feet (60 meters).
- B. The prevailing wind speed, V_w , is 10 ft/sec (3 m/sec).
- C. The combination of stack height, wind velocity and fall velocity of the fibers determines the maximum radius for the fallout of airborne fibers.
- D. The fallout radius will be used to calculate the total area. Fifty percent of airborne fibers resulting from incineration of carbon fiber composites will fall out within one quadrant (see 7.1.5 C.). The 50% fallout area, then, is one-fourth the total area.
- E. The airborne carbon fibers will distribute uniformly over the 50% fallout area.

Table 7-3 summarizes the calculations for the two cases of interest: long fibers which pose an electrical hazard; and short, respirable fibers.

TABLE 7-3 DISTRIBUTION OF AIRBORNE CARBON FIBER RELEASED BY INCINERATION

	<u>ELECTRICAL</u>	<u>RESPIRABLE</u>
Radius of Fallout, R. $R = (H_s/V_s) \times V_w$	9,000 m	33,962 m
Total 50% Fallout Area, A_{50} . $A_{50} = \frac{1}{4} \pi (R^2) (54)$	$3.44 \times 10^9 \text{m}^2$	$4.89 \times 10^{10} \text{m}^2$
Total Fibers Released Per Year, F_t . $F_t = (\text{Mass burned/year}) \times N$	1.06×10^{13} fibers/year	2.01×10^{14} fibers/year
Yearly Fiber Deposition in 50% Fallout Area, D_{50} . $D_{50} = \frac{1}{2} F_t/A_{50}$	1,540 F/m ² -yr	2,055 F/m ² -yr
Population of 50% Fallout Area (based on 1,000 persons/km ²)	3.44×10^6	4.89×10^7
Number of Electrical Items in 50% Fallout Area (based on 5,000 items/km ²)	1.72×10^7	

7.2 PROJECTIONS OF EMISSION EFFECTS

7.2.1 PROJECTIONS OF FAILURES IN ITEMS OF ELECTRICAL EQUIPMENT

The ability of airborne carbon fibers to cause failures in electrical equipment has been related to an exposure, E , defined as:

$$E = \int C dt \quad (1)$$

where C is the concentration of fibers.

A deposition of fibers, D , can be interpreted as a concentration moving at a fall velocity for a period of time.

$$D = \int C V_s dt; \quad (2)$$

with V_s constant,

$$D = V_s \int C dt, \text{ and}$$

$$D/V_s = \int C dt \equiv E. \quad (3)$$

The probability of an electrical failure from an exposure, P_f , is defined by the linear exponential relationship:

$$P_f = 1 - e^{-(E/\bar{E})}, \quad (4)$$

where \bar{E} is the average exposure necessary to cause electrical failure.

Where the ambient exposure, E , is less than $0.01 \bar{E}$, a series expansion leads to the approximation:

$$P_f \approx E/\bar{E}. \quad (5)$$

Electrical equipment in a residential community is usually located in areas which attenuate the entry of fibers. Application of the appropriate transfer function, T_f , to the ambient concentration leads to:

$$\begin{aligned} E &= (D/V_s) \times T_f \\ &= (1540/0.02) (0.1) \\ &= 7700 \text{ fiber-seconds/meter}^3, \end{aligned}$$

and

$$\begin{aligned}
P_f &= E/\bar{E} \\
&= 7700/10^7 \\
&= 7.7 \times 10^{-4}
\end{aligned}$$

Assuming the average household to consist of four persons, and twenty electrical items, each year one out of sixty-five households would experience a failure of an electrical device attributable to carbon fiber fallout. On a national scale, the total number of electrical failures becomes:

$$\begin{aligned}
\text{Failures} &= (\text{Number of units}) \times (P_f) \\
&= (1.72 \times 10^7) \times (7.7 \times 10^{-4}) \\
&= 13,220 \text{ failures per year.}
\end{aligned}$$

A comparison of this prediction against the current rate of repairs on television receivers offers a perspective for the impact on the community. Data from television manufacturing sources show one TV receiver for each 1.7 of population and new televisions make up 15 percent of the total. On this basis, 2.02×10^6 television sets will be in the area affected by 50 percent of the released fibers. The current failure rate of television receivers has been used to develop an estimate of the annual, non-carbon fiber related, functional failures which would be expected in this population of two million sets. These estimates are shown in Table 7-4.

TABLE 7-4 TELEVISION FAILURE RATES

<u>Age of Set</u>	<u>Number</u>	<u>Failure Rate</u>	<u>Failures</u>
0-3 months	75,750	0.08	6,060
3-12 months	227,250	0.02	4,545
Older than 12 months	1,717,000	0.02	34,340
Total Annual Functional Failures			44,945

The predictions for carbon fiber failures of all household appliances approaches one-third the presently experienced value for failures of television sets alone, from all causes. Although the predicted impact appears to be relatively small, the value is statistically significant; a more detailed analysis of electrical interactions appears justified.

7.2.2 EMISSIONS OF RESPIRABLE CARBON FIBERS

A parallel calculation can be performed for carbon fibers of a respirable size. Here the annual exposure takes the form:

$$\begin{aligned} E &= D/V_s \\ &= 2,055 / 5.3 \times 10^{-3} \\ &= 3.89 \times 10^5 \text{ fiber-sec/meter}^3. \end{aligned}$$

For comparison, consider the new, lowered value proposed by the NIOSH for exposure to asbestos fiber in the working environment: 1.0×10^5 fibers/m³ maximum for eight hours. For this case, the daily exposure is:

$$\begin{aligned} E_{\text{asbestos}} &= (1 \times 10^5) (8) (60) (60) \\ &= 2.88 \times 10^9 \text{ fiber-sec/meter}^3. \end{aligned}$$

For an individual in the area of the highest fallout, it would take 7,400 years to receive an exposure equivalent to the one day workplace limit. Respirable fibers released from incinerators do not appear to present a significant increment to the population of fibrous aerosols.

7.2.3 AREAS FOR FURTHER CONSIDERATION

The further analysis of carbon fiber emissions should include the following three considerations:

1. Fallout From Plumes.

The dispersion patterns from stacks have been analyzed mathematically; models exist which account for differences in weather conditions. An emission study based upon these models would verify the worst case condition for fallout. The study would probably have to address specific incinerators.

2. Fiber Interaction Within the Incinerator.

The predictions of carbon fiber emissions assumed all the fibers released in the hot zone were emitted from the stack. No modeling was attempted for fallout in flow passages, or for the effects of air pollution control devices such as bag houses, water sprays or precipitators. In addition, flow velocities in incinerators may reach the

threshold values for break up of fibers (~ 30 m/sec). A study of a specific unit would facilitate the parametric analysis of these specific effects.

3. Quantity of Carbon Fiber in the Waste Streams.

These predictions assumed a uniform rate for carbon fiber composites entering an incinerator. Carbon fiber materials will enter waste streams as pieces. Fiber release will tend to be in bursts. A study of a specific facility should address the effects of discrete quantities of carbon fiber scrap moving in the waste stream.

8.0 INTERAGENCY DATA EXCHANGE

8.1 INTRODUCTION

Federal agencies will continue their efforts in studying and assessing carbon fiber composites. In order to do this effectively and efficiently, a program is needed whereby the interchange of information and data can be accomplished. Within each agency or functional group, a leader or coordinator of carbon fiber related matters has been identified. These names, together with the leaders of specific developments and representatives from monitoring agencies have been compiled to produce a Directory and Locator for the National Graphite Fiber Program. The Directory is included as Appendix A of this report and is designed to permit publication as a separate volume.

The information contained within the Directory is the best available at the time of publication. It will be the responsibility of the holder of the Directory to update his/her copy as changes arise. It is suggested that changes in personnel, titles, or locations in the Directory be distributed to all other persons listed in the Directory. The back pages of the Directory include the elements for implementing the Interagency Data Exchange Plan described below.

8.2 DISTRIBUTION OF CARBON FIBER RELATED INFORMATION AND DATA

The continuing carbon fiber related effort will generate formal reports, data from studies and pertinent information best described as "experience". The sharing of this information between agencies implies the identification of an interest in such information plus a distribution list. Table 8-1 identifies the type of carbon fiber data which will be generated and identifies those agencies which would have an interest in receiving such information. This Table has been reproduced as one of the back pages in the Directory, and defines a distribution list for any type of information. The back pages in the Directory include a Master Distribution List containing the name and address of the key person in each of the agencies listed and in the same order as the agency listing in the Table 8-1. To generate an appropriate distribution list, the content area must be defined, and the form of the material (report, data, experience) identified. By reading from left to right across the page on the appropriate line, the agencies

which are to receive the material are indicated by an "R". Using a reproduction of the Master Distribution List, the appropriate "Receive" and "Not Receive" boxes can be checked off to produce a distribution list specific to the information at hand.

The six major Content Areas in the left hand column of Table 8-1 have been chosen as those areas in which material is most likely to be generated. Inspection of Table 8-1 indicates that the EPA, the DOD, the NASA, the FEMA, and the OSTP will receive information in all content areas and most formats. For areas or forms not specifically covered in the Table, inspection of the receiving agencies in the categories which are listed will aid in the development of a distribution list. For example, a report on Handling and Fabrication (not anticipated in the Table) would receive a distribution similar to that indicated for data in this content area. Some logical adjustments might also be made: a report on application of carbon fibers to high voltage transmission conductors would be additionally distributed to the appropriate person in the Department of Energy, although that person would not receive general application reports in other areas, such as automotive or sporting goods.

8.3 GENERATION OF CARBON FIBER RELATED INFORMATION AND DATA

A secondary need related to Federal carbon fiber programs is the requirement to obtain data and information concerning a specific area of interest. Table 8-2 has been provided as a basis on which to begin obtaining such information and this table also appears as a back page in the Directory. The Table shows which Federal agencies are likely to generate reports or data or have experience in each content area. The Table indicates which agencies should be contacted in order to receive up-to-date information. Used in conjunction with the Directory, the individual most likely to be engaged in investigations in the desired content area can be identified. Within the Directory, the specific area of interest or expertise of persons or groups within an agency is included.

TABLE 8-1. INTERAGENCY INFORMATION EXCHANGE DISTRIBUTION LIST

(R = Agency should receive material)

CONTENT AREA	FORM*	EPA		DOD					NASA		FEMA	OSTP	DOE	DHHS	DOT		DOL	DOC
		MERL	ESRL	JTCG	USAF	USN	ARMY	HQ	LaRC	FAA					SYST			
1. FIBER RELEASE INCIDENTS																		
	Aircraft Accidents	R	R	R	R	R	R	R	R	R	R	R	R	R	R	-	-	-
	Report	R	R	R	R	R	R	R	R	R	R	R	R	R	R	-	-	-
	Data	R	R	R	R	R	R	R	R	R	R	R	R	R	R	-	-	-
Industrial or Transport Accidents	Report	R	R	R	R	R	R	R	R	R	-	R	R	R	-	R	-	R
	Data	R	R	R	R	R	R	R	R	R	-	R	R	R	-	R	-	R
2. CONTROL OF AIRBORNE FIBERS																		
	Emissions Measurements	R	R	R	R	R	R	R	R	-	R	R	R	R	-	-	-	-
	Report	R	R	R	R	R	R	R	R	-	R	R	R	R	-	-	-	-
	Data	R	R	R	R	R	R	R	R	-	R	R	R	R	-	-	-	-
Emission Analysis	Report	R	R	R	R	R	R	R	-	R	R	R	R	-	-	-	-	
Surveys of Facilities	Report	R	R	R	R	R	R	R	-	R	R	R	R	-	-	-	-	
	Data	R	R	R	R	R	R	R	-	R	R	R	R	-	-	-	-	
3. INSTRUMENTATION																		
	Sensors and Monitors	Report	R	R	R	R	R	R	R	R	R	R	R	-	R	-	-	-
	Data	R	R	R	R	R	R	R	R	R	R	R	R	-	R	-	-	-
	Experience	R	R	R	R	R	R	R	R	R	R	R	R	-	R	-	-	-
	Systems Studies	Report	R	R	R	R	R	R	R	R	R	R	R	-	-	-	-	-
	Analytical Techniques	Report	R	R	R	R	R	R	R	R	R	R	R	-	-	-	-	-
	Dispensing Units	Report	R	R	R	R	R	R	R	R	R	R	R	-	-	-	-	-
	Data	R	R	R	R	R	R	R	R	R	R	R	-	-	-	-	-	
	Experience	R	R	R	R	R	R	R	R	R	R	R	-	-	-	-	-	
4. AIRBORNE FIBERS																		
	Electrical Effects	Report	R	R	R	R	R	R	R	R	R	R	R	R	R	R	R	-
	Data	R	R	R	R	R	R	R	R	R	R	R	R	R	R	R	R	-
	Experience	R	R	R	R	R	R	R	R	R	R	R	R	R	R	R	R	-
	Health Effects	Report	R	R	R	R	R	R	R	-	R	R	R	R	-	-	-	R
	Data	R	R	R	R	R	R	R	R	-	R	R	R	R	-	-	-	R
	Experience	R	R	R	R	R	R	R	R	-	R	R	R	R	-	-	-	R
	Building Penetration	Report	R	R	R	R	R	R	R	R	R	R	R	R	-	-	-	R
	Data	R	R	R	R	R	R	R	R	R	R	R	R	R	-	-	-	R
	Experience	R	R	R	R	R	R	R	R	R	R	R	R	R	-	-	-	R
Handling & Fabrication	Data	R	R	R	R	R	R	R	R	R	R	R	R	-	-	-	-	
	Experience	R	R	R	R	R	R	R	R	R	R	R	R	-	-	-	-	
5. FIBERS IN COMMERCE																		
	Application Developments	Report	R	R	R	R	R	R	R	R	R	R	-	-	-	R	-	R
	Data	R	R	R	R	R	R	R	R	R	R	R	-	-	-	R	-	R
	Experience	R	R	R	R	R	R	R	R	R	R	R	-	-	-	R	-	R
	Materials Developments	Report	R	R	R	R	R	R	R	R	R	R	-	-	-	R	-	R
Data	R	R	R	R	R	R	R	R	R	R	R	-	-	-	R	-	R	
Experience	R	R	R	R	R	R	R	R	R	R	R	-	-	-	R	-	R	
Manufacturing Developments	Report	R	R	R	R	R	R	R	R	R	R	-	-	-	R	R	-	
Data	R	R	R	R	R	R	R	R	R	R	R	-	-	-	R	R	-	
Experience	R	R	R	R	R	R	R	R	R	R	R	-	-	-	R	R	-	
Economic and Utilization Studies	Report	R	R	R	R	R	R	R	R	R	R	R	-	-	R	-	R	
	Data	R	R	R	R	R	R	R	R	R	R	R	-	-	R	-	R	
	Experience	R	R	R	R	R	R	R	R	R	R	R	-	-	R	-	R	
6. DISPOSAL TECHNOLOGY																		
	Present Disposal Methods	Report	R	R	R	R	R	R	-	R	R	R	-	-	-	-	-	-
	Data	R	R	R	R	R	R	R	-	R	R	R	-	-	-	-	-	-
	Experience	R	R	R	R	R	R	R	-	R	R	R	-	-	-	-	-	-
	Advanced Disposal Systems	Report	R	R	R	R	R	R	-	R	R	R	-	-	R	R	R	-
	Data	R	R	R	R	R	R	R	-	R	R	R	-	-	R	R	R	-
Experience	R	R	R	R	R	R	R	-	R	R	R	-	-	R	R	R	-	
Requirements & Studies	Report	R	R	R	R	R	R	-	R	R	R	-	-	R	-	-	-	
Data	R	R	R	R	R	R	R	-	R	R	R	-	-	R	-	-	-	
Experience	R	R	R	R	R	R	R	-	R	R	R	-	-	R	-	-	-	

* Report includes reports and formal publications
 Data includes informal data and preliminary reports
 Experience includes memoranda of interest, unpublished notes, etc.

TABLE 8-2. INTERAGENCY INFORMATION GENERATION LIST

(G = Agency likely to generate materials)

SUBJECT MATTER	EPA		DOD		NASA		FEMA	OSTP	DOE	NIOSH	DOT		OSHA	DOC
	ERL	ESRL	USAF	USN	ARMY	HQ					LaRC	FAA		
1. FIBER RELEASE INCIDENTS														
Aircraft Accidents			G	G	G						G			
Industrial or Transport Accidents							G							
2. CONTROL OF AIRBORNE FIBERS														
Emissions Measurements	G	G					G							
Emission Analysis	G	G												
Surveys of Facilities	G	G	G	G	G		G		G					
3. INSTRUMENTATION														
Sensors and Monitors		G	G	G	G				G					
Systems Studies		G	G	G	G				G					
Analytical Techniques		G	G	G	G				G					
Dispensing Units		G	G	G	G				G					
4. AIRBORNE FIBERS														
Electrical Effects	G		G	G	G				G				G	
Health Effects	G									G			G	
Building Penetration	G		G	G	G									
Handling and Fabrication			G	G	G								G	
5. FIBERS IN COMMERCE														
Application Developments			G	G	G							G		
Materials Developments			G	G	G							G		
Manufacturing Developments			G	G	G							G		
Economic and Utilization Studies												G		
6. DISPOSAL TECHNOLOGY														
Present Disposal Methods	G		G	G	G									
Advanced Disposal Systems	G													
Requirements and Studies	G		G	G	G									

APPENDIX A

DIRECTORY AND LOCATOR

NATIONAL GRAPHITE FIBER PROGRAM

FEDERAL OPERATION OR TASK LEADERS

	<u>PAGE</u>
OFFICE OF SCIENCE AND TECHNOLOGY POLICY	219
FEDERAL AGENCIES	
Environmental Protection Agency.	219
Federal Emergency Management Agency.	221
National Aeronautical and Space Administration	222
FEDERAL DEPARTMENTS	
Department of Commerce	223
Department of Defense	224
Department of Energy	226
Department of Health and Human Services	226
Department of Labor	226
Department of State	227
Department of Transportation	227
FEDERAL SUPPORT OPERATIONS	
Central Intelligence Agency	228
General Accounting Office	228
Office of Management and Budgets	228
Table A-1. Interagency Information Exchange Distribution List.	229
Table A-2. Interagency Information Generation List	230
Figure A-1. Master Distribution List	231

OFFICE OF SCIENCE AND TECHNOLOGY POLICY

- Overall direction, coordination and control monitor for the Carbon Fiber Action Plan

Col. Wayne Kay, Director

Address:

Office of Science & Technology Policy
Attention: Col. Wayne Kay
Old Executive Office Building
Room 483
Washington, D.C. 20500

Telephone:

(202) 395-3272
FTS 395-3272

FEDERAL AGENCIES

ENVIRONMENTAL PROTECTION AGENCY

1. Municipal Environmental Research Laboratory

- Agency coordinator for EPA activities
- Carbon fiber waste management and disposal technology development

Dr. Benjamin L. Blaney

Address:

U.S. Environmental Protection Agency
Industrial Environmental Research Laboratory
Cincinnati, Ohio 45268

Telephone:

(513) 684-4417
FTS 684-4417

(EPA con't)

2. Environmental Sciences Research Laboratory

- Coordination of activities for EPA activity within ESRL
- Carbon fiber emission characterization; development of monitoring instrumentation and measurement techniques

Dr. J. Wagman

Address:

Environmental Protection Agency
Environmental Sciences Research Laboratory
Attention: Dr. J. Wagman
Research Triangle Park, North Carolina 27711

Telephone:

(919) 541-3009
FTS 629-3009

- Development of specialized measurement and analysis techniques for carbon fibers

<u>CONTRIBUTOR</u>	<u>ROLE</u>	<u>MAIL CODE</u>	<u>FTS-TELEPHONE</u>
Mr. R. L. Bennett	Standard Method Development	MD 46	629-3785
Mr. W. D. Connor	Continuous Monitor Instruments	MD 46	629-3894
Dr. R. Shaw	Measurements of Collected Samples	MD 47	629-3148
Dr. C. W. Lewis	Ambient Measurement Instruments and Technology	MD 47	629-3154

Address:

Environmental Protection Agency
Environmental Sciences Research Laboratory
MD- (See Above)
Research Triangle Park, North Carolina 27711

Telephone

(919) 541-3173/48/54
FTS 629-3173/48/54

FEDERAL EMERGENCY MANAGEMENT AGENCY

1. Staff College

- Technical information and briefing to local governments. Fire, police emergency services procedures for handling a carbon fiber fire release incident

Mr. Thomas Boven

Address:

FEMA Staff College
Federal Center
Battle Creek, MI 49106

Telephone:

(616) 962-6171
FTS 372-6171

2. FEMA Emergency Center

- Data and record compilation and analysis for carbon fiber fire release incidents

James Thomas
Preparedness Development Division

Address:

Federal Emergency Management Agency
1725 "I" St., NW
(GSA)
Washington, D.C. 20472

Telephone:

(202) 566-0981
FTS 566-0981

NATIONAL AERONAUTICAL AND SPACE ADMINISTRATION

1. NASA Headquarters

- Coordinator of NASA activities and research

Dr. Leonard A. Harris

Address:

NASA Headquarters
Code RTM 6
Washington, D.C. 20546

Telephone:

(202) 755-3261
FTS 755-3261

2. NASA Langley Research Center

- Graphite Fiber Risk Analysis Program Office

Mr. Robert Huston, Program Manager

Address:

NASA Langley Research Center
Mail Stop 231
Hampton, Virginia 23665

Telephone:

(804) 827-2851
FTS 928-2851

- Aircraft Energy Efficiency Project Office

Dr. R. W. Leonard

Address:

NASA Langley Research Center
Mail Stop 158
Hampton, Virginia 23665

Telephone:

(804) 827-2809
FTS 928-2809

FEDERAL DEPARTMENTS

DEPARTMENT OF COMMERCE

1. Office of Basic Industries

- Carbon fiber data base and dissemination of information

Mr. Donald Parsons

Address:

Office of Basic Industries
Bureau of Domestic Business Development
U.S. Department of Commerce
Washington, D.C. 20230

Telephone:

(202) 566-7728
FTS 566-7728

2. National Bureau of Standards

- Evaluation of consumer electrical and electronic equipment (also support to Graphite Fiber Risk Analysis)

Mr. Denver Lovett

Address:

National Bureau of Standards
Building 202, Room 216
Washington, D.C. 20234

Telephone:

(301) 921-3828
FTS 921-3828

DEPARTMENT OF DEFENSE

1. Joint Technical Coordinating Group

- Chief JTCG

Mr. Raymond Polcha

Address:

Chairman, JTCG
Naval Surface Weapons Center
Code F-56 (R. Polcha)
Dahlgren, Virginia 22448

Telephone:

(703) 663-8781
FTS 937-6011
(Roanoke)

- Former Chief JTCG

Lt. Col. Lawrence Abramson

Address:

Director
Ballistics Research Laboratory
USA AVRADCOM
Attention: DRDAR-BLC-HN/Lt. Col. L. Abramson
Aberdeen Proving Ground, Maryland 21005

Telephone:

(301) 278-3086
FTS 922-3311
(Baltimore)

2. U.S. Air Force Coordination and Direction of Activities

Mr. Quentin Porter

Address:

Commanding Officer
Rome Air Development Center/RBTC
RAPCIRB Attention: Q. Porter
Griffiss AFB, New York 13441

Telephone:

(315) 330-3061
FTS 952-3061

DOD (con't)

3. U.S. Army Coordination and Direction of Activities

- Army Coordinator

J. A. (Lex) Morrissey

Address:

DRDAR-BLV
Attention: J. A. Morrissey
Radiation Engineering Branch BRL
Aberdeen Proving Ground EA, Maryland 21005

Telephone:

(301) 671-2340
FTS 922-3311
(Baltimore)

- Consultant

Dr. L. R. Vande Kieft

Address:

Director
Ballistics Research Laboratory
USA AVRADCOM
Attention: DRDAR-BLT-HN/Dr. L. R. Vande Kieft
Aberdeen Proving Ground, Maryland 21005

Telephone:

(301) 278-2632
(301) 278-2528
FTS 922-3311
(Baltimore)

4. U.S. Navy Coordination and Direction of Activities

C. E. Gallaher

Address:

Naval Surface Weapons Center
Attention: Code CF 56 (C. E. Gallaher)
Dahlgren, Virginia 22448

Telephone:

(703) 663-8136
FTS 937-6011
(Roanoke)

DEPARTMENT OF ENERGY

- Effects of airborne fibers on power generation and distribution equipment

Mr. Thomas Garrity

Address:

Division of Electric Energy Systems
Energy Research and Development Administration
200 Massachusetts Avenue, NW
Washington, D.C. 20545

Telephone:

(202) 376-4595
FTS 376-4595

DEPARTMENT OF HEALTH AND HUMAN SERVICES

- Carbon fiber environment studies
- Morbidity mortality studies on exposure to other fibrous materials (continuation of existing programs as basis for comparison)

Mr. Ralph Zumwalde

Address:

U.S. Public Health Service
Robert A. Taft Laboratories
4676 Columbia Parkway
Cincinnati, Ohio 45226

Telephone:

(513) 684-3255
FTS 684-3255

DEPARTMENT OF LABOR

- Review and comparison analysis relative to development of a regulation for carbon fiber exposure in a worker environment

Dr. R. Hays Bell

Address:

Department of Labor, OSHA
Attention: Dr. R. Hays Bell
200 Constitution Avenue, N.W.
Room N-3651
Washington, D.C. 20210

Telephone:

(202) 523-7031
FTS 523-7031

DEPARTMENT OF STATE

- International coordination and dissemination of carbon fiber related data or information

Mr. Jack Blanchard

Address:

Department of State
Office of Environmental Health
Attention: Mr. Jack Blanchard
oom 7820
Washington, D.C. 20520

Telephone:

(202) 632-5748
FTS 632-5748

DEPARTMENT OF TRANSPORTATION

1. Transportation System Center, Cambridge, Massachusetts

- Carbon Fiber Studies Project Office

Dr. Karl Hergenrother

Address:

Dr. K. Hergenrother/521
Transportation Systems Center
Kendall Square
Cambridge, Massachusetts 02142

Telephone:

(617) 494-2696
FTS 837-2696

2. The Federal Aviation Administration

- Coordination of accident data involving carbon fiber on civil aircraft
- Notification of incidents involving carbon fiber release from civil aircraft

Mr. A. E. Anderjaska Telephone: (202) 426-8382
Agency Coordination FTS 426-8382

Mr. W. Brennan Telephone: (202) 426-3120
Accident Investigation FTS 426-3120

Address:

Federal Aviation Administration
AWS 120
800 Independence Avenue
Washington, D.C. 20546

FEDERAL SUPPORT OPERATIONS

CENTRAL INTELLIGENCE AGENCY

- Coordination of information for the CIA

Mr. Ronald Stocks

Address:

Central Intelligence Agency
OSWR/STP
Attention: Mr. Ronald Stocks
Washington, D.C. 20505

Telephone:

(703) 351-5393
FTS (202) 351-5393

GENERAL ACCOUNTING OFFICE

- General program review

Mr. C. Boykin

Address:

General Accounting Office
Attention: Mr. C. Boykin
Room 2220 Annex, SSA
Woodlawn, Maryland 21235

Telephone:

(301) 594-4430
FTS 934-4430

OFFICE OF MANAGEMENT AND BUDGETS

- Allocations of financial resources and budget planning

Dr. K. Mohan

Address:

Office of Management and Budget
Room 8002
New Executive Office Building
Washington, D.C. 20503

Telephone:

(202) 395-3935
FTS 395-3935

TABLE A-1. INTERAGENCY INFORMATION EXCHANGE DISTRIBUTION LIST

(R = Agency should receive material)

CONTENT AREA	FORM*	EPA		DOD				NASA		FEMA	OSTP	DOE	DHHS	DOT		DOL	DOC
		MERL	ESRL	JTCG	USAF	USN	ARMY	HQ	LaRC					FAA	SYST		
1. FIBER RELEASE INCIDENTS	Aircraft Accidents Report Data	R	R	R	R	R	R	R	R	R	R	R	R	R	-	-	-
		R	R	R	R	R	R	R	R	R	R	R	R	R	-	-	-
Industrial or Transport Accidents	Report Data	R	R	R	R	R	R	R	R	-	R	R	R	-	R	-	R
	R	R	R	R	R	R	R	R	R	-	R	R	R	-	R	-	-
2. CONTROL OF AIRBORNE FIBERS	Emissions Measurements Report Data	R	R	R	R	R	R	R	-	R	R	R	R	-	-	-	-
		R	R	R	R	R	R	R	-	R	R	R	R	-	-	-	-
	Emission Analysis Report	R	R	R	R	R	R	R	-	R	R	R	R	-	-	-	-
		R	R	R	R	R	R	R	-	R	R	R	R	-	-	-	-
Surveys of Facilities Report Data	R	R	R	R	R	R	R	-	R	R	R	R	-	-	R	-	
	R	R	R	R	R	R	R	-	R	R	R	R	-	-	-	-	
3. INSTRUMENTATION	Sensors and Monitors Report Data Experience	R	R	R	R	R	R	R	R	R	R	R	-	R	-	-	-
		R	R	R	R	R	R	R	R	R	-	R	-	R	-	-	-
		R	R	R	R	R	R	R	R	R	-	R	-	R	-	-	-
	Systems Studies Report	R	R	R	R	R	R	R	R	R	R	R	-	-	-	-	-
		R	R	R	R	R	R	R	R	R	R	R	-	-	-	-	-
	Dispensing Units Report Data Experience	R	R	R	R	R	R	R	R	R	R	R	-	-	-	-	-
R	R	R	R	R	R	R	R	R	R	-	R	-	-	-	-	-	
4. AIRBORNE FIBERS	Electrical Effects Report Data Experience	R	R	R	R	R	R	R	R	R	R	R	R	R	R	R	-
		R	R	R	R	R	R	R	R	R	R	R	R	R	R	R	-
		R	R	R	R	R	R	R	R	R	R	R	R	R	-	-	-
	Health Effects Report Data Experience	R	R	R	R	R	R	R	-	R	R	R	R	-	-	R	-
		R	R	R	-	-	-	-	-	R	R	R	R	-	-	-	-
	Building Penetration Report Data Experience	R	R	R	R	R	R	R	R	R	R	R	R	-	R	R	-
		R	R	R	R	R	R	-	R	R	R	R	R	-	R	R	-
	Handling & Fabrication Data Experience	R	R	R	R	R	R	R	R	R	R	R	R	-	-	-	-
R		R	R	R	R	R	R	R	R	R	R	R	-	-	-	-	
5. FIBERS IN COMMERCE	Application Developments Report Data	R	R	R	R	R	R	-	R	R	-	-	-	-	R	-	R
		R	-	R	R	R	R	-	R	-	-	-	-	-	-	-	-
	Materials Developments Report Data	R	R	R	R	R	R	R	R	R	-	-	R	-	R	-	R
		R	-	R	R	R	R	-	R	-	-	-	-	-	-	-	-
Manufacturing Developments Report Data	R	R	R	R	R	R	R	R	R	-	-	-	-	R	R	-	
	R	-	R	R	R	R	-	R	-	-	-	-	-	-	-	-	
Economic and Utilization Studies Report	R	R	R	R	R	R	R	R	R	R	R	R	-	R	-	R	
6. DISPOSAL TECHNOLOGY	Present Disposal Methods Report Data Experience	R	R	R	R	R	R	-	R	R	-	-	-	-	-	-	-
		R	R	R	R	R	R	-	R	-	-	-	-	-	-	-	-
		R	-	R	R	R	R	-	R	-	-	-	-	-	-	-	-
	Advanced Disposal Systems Report Data Experience	R	R	R	R	R	R	-	R	R	-	-	R	R	R	-	-
		R	R	R	R	R	R	-	R	-	-	-	-	-	-	-	-
	Requirements & Studies Report Data Experience	R	R	R	R	R	R	-	R	R	-	-	R	-	-	-	-
R	-	R	R	R	R	-	R	-	-	-	-	-	-	-	-	-	

* Report includes reports and formal publications
Data includes informal data and preliminary reports
Experience includes memoranda of interest, unpublished notes, etc.

TABLE A-2. INTERAGENCY INFORMATION GENERATION LIST

(G = Agency likely to generate materials)

SUBJECT MATTER	EPA		DOD		NASA		NIOSH		OSHA		DOT		
	IERL	ESRL	USAF	USN	ARMY	HQ	LaRC	FEMA	OSTP	DOE	NIOSH	FAA	SYST
1. FIBER RELEASE INCIDENTS													
Aircraft Accidents	-	-	G	G	G	-	-	-	-	-	-	G	-
Industrial or Transport Accidents	-	-	-	-	-	-	-	G	-	-	-	-	-
2. CONTROL OF AIRBORNE FIBERS													
Emissions Measurements	G	G	-	-	-	-	G	-	-	-	-	-	-
Emission Analysis	G	G	-	-	-	-	-	-	-	-	-	-	-
Surveys of Facilities	G	G	G	G	G	-	G	-	-	G	-	-	-
3. INSTRUMENTATION													
Sensors and Monitors	-	-	G	G	G	-	-	-	-	G	-	-	-
Systems Studies	-	-	G	G	G	-	-	-	-	G	-	-	-
Analytical Techniques	-	-	G	G	G	-	-	-	-	G	-	-	-
Dispensing Units	-	-	G	G	G	-	-	-	-	G	-	-	-
4. AIRBORNE FIBERS													
Electrical Effects	G	-	G	G	G	-	G	-	-	G	-	-	G
Health Effects	G	-	-	-	-	-	-	-	-	-	-	-	G
Building Penetration	G	-	G	G	G	-	G	-	-	-	-	-	-
Handling and Fabrication	-	-	G	G	G	-	G	-	-	-	-	-	G
5. FIBERS IN COMMERCE													
Application Developments	-	-	G	G	G	-	G	-	-	-	-	G	-
Materials Developments	-	-	G	G	G	-	G	-	-	-	-	G	-
Manufacturing Developments	-	-	G	G	G	-	G	-	-	-	-	G	-
Economic and Utilization Studies	-	-	-	-	-	-	G	-	-	-	-	G	-
6. DISPOSAL TECHNOLOGY													
Present Disposal Methods	G	-	G	G	G	-	-	-	-	-	-	-	-
Advanced Disposal Systems	G	-	-	-	-	-	-	-	-	-	-	-	-
Requirements and Studies	G	-	G	G	G	-	-	-	-	-	-	-	-

<u>ENVIRONMENTAL PROTECTION AGENCY</u>			<u>FEDERAL EMERGENCY MANAGEMENT AGENCY</u>		
<u>Industrial Environmental Research Laboratory</u>	EPA-IERL	-R- -NR-	James Thomas	FEMA	-R- -NR-
Dr. Benjamin L. Blaney			Preparedness Development Division		
Environmental Protection Agency			Federal Emergency Management Agency		
Industrial Environmental Research Laboratory			1725 "I" St., NW		
Cincinnati, Ohio 45268			(GSA Building, Room 501A)		
<u>Environmental Sciences Research Laboratory</u>	EPA-ESRL		Washington, D. C. 20472		
Dr. J. Wagman			<u>OFFICE OF SCIENCE AND TECHNOLOGY POLICY</u>		
Environmental Protection Agency			Col. Wayne Kay	OSTP	
Environmental Sciences Research Laboratory			Office of Science & Technology Policy		
Attention: Dr. J. Wagman			Attention: Col. Wayne Kay		
Research Triangle Park, North Carolina 27711			Old Executive Office Building		
<u>DEPARTMENT OF DEFENSE</u>			Room 483		
<u>Joint Technical Coordinating Group</u>	DOD-JTCG		Washington, D. C. 20500		
Mr. Raymond Polcha			<u>DEPARTMENT OF ENERGY</u>		
Chairman, JTCG			Mr. Thomas Garrity	DOE	
Naval Surface Weapons Center			Division of Electric Energy Systems		
Code F-56 (R. Polcha)			Energy Research and Development Administration		
Dahlgren, Virginia 22448			200 Massachusetts Avenue, NW		
<u>United States Air Force</u>	DOD-USAF		Washington, D. C. 20545		
Mr. Quentin Porter			<u>DEPARTMENT OF HEALTH AND HUMAN SERVICES</u>		
Commanding Officer			Mr. Ralph Zumwalde	DHHS	
Rome Air Development Center/RBTC			U. S. Public Health Service		
RAPCIIRB Attention: Q. Porter			Robert A. Taft Laboratories		
Griffiss AFB, New York 13441			4676 Columbia Parkway		
<u>United States Navy</u>	DOD-USN		Cincinnati, Ohio 45226		
C. E. Gallaher			<u>DEPARTMENT OF TRANSPORTATION</u>		
Naval Surface Weapons Center			<u>Federal Aviation Administration</u>		
Attention: Code CP 56 (C. E. Gallaher)			Mr. A. E. Anderjaska	DOT-FAA	
Dahlgren, Virginia 22448			Federal Aviation Administration		
<u>United States Army</u>	DOD-ARMY		AAS 120		
J. A. (Lex) Morrissey			800 Independence Avenue		
DRDAR-BLV			Washington, D. C. 20546		
Attention: J. A. Morrissey			<u>Transportation System Center</u>		
Radiation Engineering Branch BRL			Dr. Karl Hergenrother	DOT-SYST	
Aberdeen Proving Ground EA, Maryland 21005			Dr. K. Hergenrother/521		
<u>NATIONAL AERONAUTICS AND SPACE ADMINISTRATION</u>	NASA-HQ		Transportation Systems Center		
<u>NASA Headquarters</u>			Cambridge, Massachusetts 02142		
Dr. Leonard A. Harris			<u>DEPARTMENT OF LABOR</u>		
NASA Headquarters			Dr. R. Hays Bell	DOL	
Code RTW 6			Department of Labor		
Washington, D. C. 20546			OSHA		
<u>NASA Langley Research Center</u>	NASA-LaRC		Attention: Dr. R. Hays Bell		
Mr. Robert Huston			200 Constitution Avenue, NW		
NASA Langley Research Center			Room N-3651		
Mail Stop 231			Washington, D. C. 20210		
Hampton, Virginia 23665			<u>DEPARTMENT OF COMMERCE</u>		
			Mr. Donald Parsons	DOC	
			Office of Basic Industries		
			Bureau of Domestic Business Development		
			U. S. Department of Commerce		
			Washington, D. C. 20230		

NOTE:

-R- = agency should receive material
 -NR- = agency should not receive material

Figure A-1. Master Distribution List.

You need NTIS Abstract Newsletters and here's how to order them.

Complete the order form at the bottom of this letter and mail it back today to the address below. You may use any of the options listed in order to pay for your subscription.

You are guaranteed satisfaction. If your Newsletters do not satisfy you for any reason, you may cancel and receive a credit or refund for the balance of your subscriptions.

I invite you to subscribe today.

Sincerely,

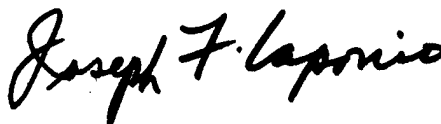

Joseph F. Caponio
Acting Director

NTIS 5285 Port Royal Road
Springfield, VA 22161 or Call (703) 487-4630

Please start my subscription to the following *Abstract Newsletters*:

Special Offer Only:

Foreign Technology _____
- Save \$15 or \$30 -
Charter Rate: 2 yrs. \$150 (Reg. Rate \$180)
Charter Rate: 1 yr. \$75 (Reg. Rate \$90)
Additional subscriptions \$25 each annually.

Name _____
Occupation _____
Company _____
Address _____
City/State/ZIP _____

Other Titles:

Title _____
 plus _____ additional subscriptions to this Newsletter \$25 each
Title _____
 plus _____ additional subscriptions to this Newsletter \$25 each
 Charge to my Deposit Account No. _____
 Here is my check to NTIS for \$ _____
 Bill me
Cost
\$ _____ Charge to American Express VISA
\$ _____ MasterCard
\$ _____ Card No. _____
\$ _____ Expires _____
\$ _____
TOTAL \$ _____
Signature _____ (required to validate order)

Of course, your subscription is tax deductible as a business expense in most instances.

More than that, when you consider the wasted time and costly mistakes the Newsletters can help you avoid, you will begin to appreciate what a practical investment NTIS Abstract Newsletters really are. For example:

- *MANUFACTURING TECHNOLOGY*: one of the newest Newsletters that meets industry's most pressing need right now...brings news of the latest research on robotics and CAD/CAM. \$125*
- *FOREIGN TECHNOLOGY*: abstracts of latest technological and scientific research in all fields from Japan, United Kingdom, France, U.S.S.R., and countries all over the world. SPECIAL CHARTER RATE: \$75*
- *ENVIRONMENTAL POLLUTION & CONTROL*: one of the most sought after Newsletters covering air, noise, solid wastes, water, pesticides, radiation, health and safety and environmental impact statements. \$95*
- *ENERGY*: brings you a wealth of information on energy use; supply and demand; power and heat generation; energy policies, regulations and studies; engines and fuels, and much more. \$95*
- *COMPUTERS, CONTROL, AND INFORMATION THEORY*: important information, and lots of it, concerning this, one of the fastest growing and most competitive industries worldwide. \$95*
- *MATERIAL SCIENCES*: applicable to nearly every industry with abstracts touching on a huge variety of processes and products. \$80*
- *MEDICINE & BIOLOGY*: covers an enormous range of information from anatomy to zoology. Every facet of medicine and biology is touched upon. \$75*

And any one of the abstracts in these Newsletters may be the added element of success for your ongoing research, contract proposals, cost reduction efforts, and profits.

NTIS regularly publishes information not available elsewhere, and frequently brings you news of research before it appears in professional journals and magazines. You simply should not risk acting without benefit of complete, current information on what's happening in Government-sponsored research in your field.

The Newsletters are a speedy, comprehensive, economical way for you to keep current on the latest research and to cut your risk of duplicating work already available in a report from NTIS.

Your Newsletters will suggest possible directions and starting points for your own research. Knowing research applications of others will help you get more out of every research dollar you invest.

Worldwide Sources

The NTIS collection also contains selected information on scientific and technical developments around the world.

NTIS is now actively expanding its sources of foreign technology to add to more than 300,000 foreign reports already on hand--including translated materials from the U.S.S.R., other Eastern European countries, Japan, and major Western countries.

Low Subscription Rate

By now, you may well be apprehensive over the cost of this remarkable Newsletter service. If so, you will be pleasantly surprised to learn you can subscribe to the *Energy Abstract Newsletter*, for example, for about \$1.83 a week!

NTIS is a unique self-supporting Government agency offering economical information products and services on a cost-recovery basis.

You Get Reports on Research Not Published By Any Other Source

NTIS Abstract Newsletters let you know about all Government-sponsored research in your field. Each week you'll learn about research not reported or available from any other source.

And when you spot a report you need, NTIS can provide it for you in a matter of days, usually for about \$14 in paper copy or only \$4.50 in microfiche. Your Newsletters contain a handy report order form for your convenience.

Annual Subject Index Included

Your subscription includes an Annual Subject Index to give permanent reference value to your Newsletter.



**UNITED STATES DEPARTMENT OF COMMERCE
National Technical Information Service**

5285 Port Royal Road
Springfield, Virginia 22161
OFFICE OF THE DIRECTOR

**NEW NTIS
ABSTRACT NEWSLETTERS!**



Dear Professional:

I wish I could tell you how much time and money the NTIS Abstract Newsletters could save you.

But, I can't. Because I don't know how much time and money you unknowingly spend on costly research that actually duplicates the work of others. Yet this research information is readily available to you when you know how to access it.

That's what NTIS Abstract Newsletters are all about.

NTIS Abstract Newsletters Summarize
70,000 New Reports Annually

You see, NTIS information specialists index, analyze, and categorize 70,000 new research documents a year. Each report is judged for its potential value for thousands of current subscribers. Then it is summarized in a brief abstract and published in one or more Newsletters. You receive only those abstracts of interest to your professional field.

NTIS exists to help you find--and provide you with--research results and information. You'll know what you need to know--when you need to know it--with NTIS Abstract Newsletters.