

Influence of Layer-Thickness on the Strength of
Angle-Ply Laminates

Virginia Polytechnic Inst. and State Univ.
Blacksburg

Prepared for

National Aeronautics and Space Administration
Hampton, VA

Apr 82

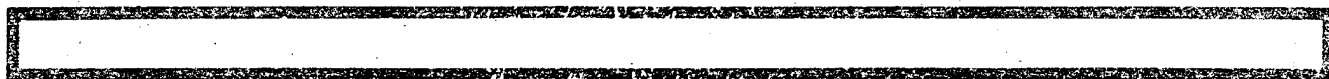
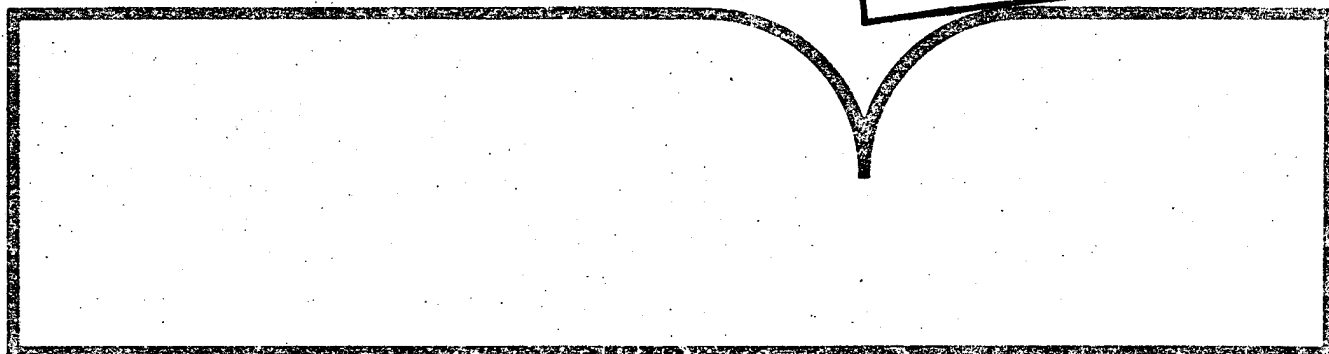
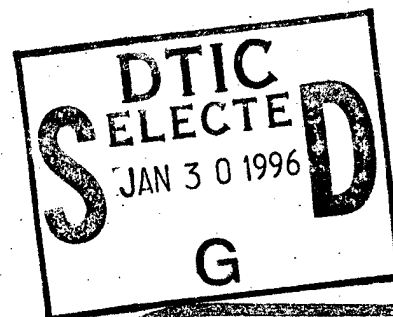

U.S. Department of Commerce
National Technical Information Service



DTIC QUALITY INSPECTED &

1995 1228 060

DISTRIBUTION STATEMENT A
Approved for public release;
Distribution Unlimited

DISCLAIMER NOTICE

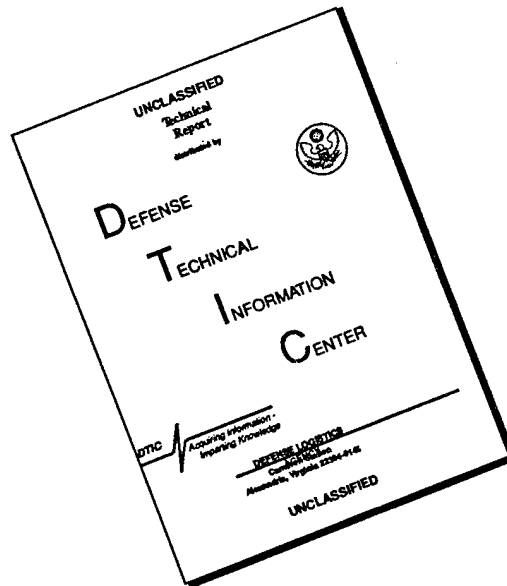

THIS DOCUMENT IS BEST QUALITY AVAILABLE. THE COPY FURNISHED TO DTIC CONTAINED A SIGNIFICANT NUMBER OF PAGES WHICH DO NOT REPRODUCE LEGIBLY.

Date: 7/15/95 Time: 6:03:20PM

Page: 1 Document Name: untitled

AD NUMBER: D436205

-- 5 - CORPORATE AUTHOR: VIRGINIA POLYTECHNIC INST AND STATE UNIV
-- BLACKSBURG DEPT OF ENGINEERING SCIENCE AND MECHANICS
-- 6 - UNCLASSIFIED TITLE: INFLUENCE OF LAYER THICKNESS ON THE
-- STRENGTH OF ANGLE-PLY LAMINATES,
--10 - PERSONAL AUTHORS: HERAKOVICH, C. T. ;
--11 - REPORT DATE: APR , 1982
--12 - PAGINATION: 30P
--15 - CONTRACT NUMBER: NCC1-15
--18 - MONITOR ACRONYM: NASA
--19 - MONITOR SERIES: CR-168892
--20 - REPORT CLASSIFICATION: UNCLASSIFIED
--22 - LIMITATIONS (ALPHA): APPROVED FOR PUBLIC RELEASE; DISTRIBUTION
-- UNLIMITED. AVAILABILITY: NATIONAL TECHNICAL INFORMATION SERVICE,
-- SPRINGFIELD, VA. 22161. N82-23554.
--33 - LIMITATION CODES: 1 24

PB82-203746

COLLEGE
OF
ENGINEERING

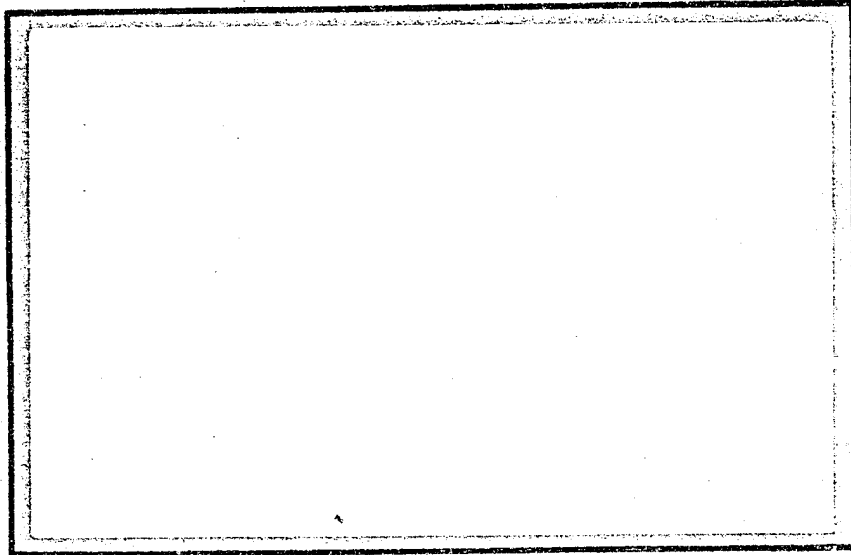

VIRGINIA
POLYTECHNIC
INSTITUTE AND
STATE
UNIVERSITY

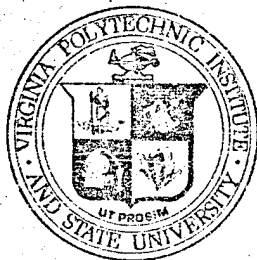

REPRODUCED BY
NATIONAL TECHNICAL
INFORMATION SERVICE
U.S. DEPARTMENT OF COMMERCE
SPRINGFIELD, VA 22161

BLACKSBURG,
VIRGINIA

College of Engineering
Virginia Polytechnic Institute & State University
Blacksburg, Virginia 24061

VPI-E-82-10

April 1982

INFLUENCE OF LAYER THICKNESS ON THE
STRENGTH OF ANGLE-PLY LAMINATES

Carl T. Herakovich

Department of Engineering Science & Mechanics

Interim Report 29
The NASA-Virginia Tech Composites Program

NASA Cooperative Agreement NCCI-15

Prepared for: Materials Processing & Application Branch
National Aeronautics & Space Administration
Langley Research Center
Hampton, Virginia 23665

203746

BIBLIOGRAPHIC DATA SHEET	1. Report No. VPI-E-82-10	2.	3. Recipient's Accession No.
	4. Title and Subtitle INFLUENCE OF LAYER THICKNESS ON THE STRENGTH OF ANGLE-PLY LAMINATES		5. Report Date
7. Author(s) C. T. Herakovich	8. Performing Organization Rept. No. VPI-E-82-10		6.
9. Performing Organization Name and Address Virginia Polytechnic Institute and State University Engineering Science & Mechanics Blacksburg, Virginia 24061		10. Project/Task/Work Unit No.	11. Contract/Grant No. CA NCCI-15
12. Sponsoring Organization Name and Address National Aeronautics & Space Administration Langley Research Center Hampton, Virginia 23665		13. Type of Report & Period Covered	14.
15. Supplementary Notes			
16. Abstracts See page 1			
17. Key Words and Document Analysis. 17a. Descriptors composites, angle-ply, strength, toughness, graphite-epoxy, finite element, layer thickness, damage, theory, experiment			
17b. Identifiers/Open-Ended Terms			
17c. COSATI Field/Group			
18. Availability Statement		19. Security Class (This Report) UNCLASSIFIED	21. No. of Pages
		20. Security Class (This Page) UNCLASSIFIED	22. Price

INFLUENCE OF LAYER THICKNESS ON THE
STRENGTH OF ANGLE-PLY LAMINATES

by

CARL T. HERAKOVICH

Department of Engineering Science and Mechanics
Virginia Polytechnic Institute and State University
Blacksburg, Virginia 24061

ABSTRACT

Experimental results are presented showing that the strength and toughness of finite-width angle-ply laminates can be increased significantly by using an alternating layer stacking sequence as opposed to a clustered configuration. The ultimate tensile stress of an alternating plus/minus θ laminate of the form $[(\pm\theta)_2]_s$ can be as much as 1.5 times that of a clustered configuration of the form $[\theta_2/-\theta_2]_s$. Further, the toughness of the alternating layer configuration can be as much as 2.7 times that of the clustered configuration. These differences are explained analytically through consideration of the influence of layer thickness on the magnitude of the interlaminar shear stress and by examination of failed specimens. It is shown that the two laminate configurations exhibit distinctly different failure modes for some fiber angles. Both laminate configurations exhibit catastrophic failure with the damage limited essentially to a small region defined by the length of a single crack across the width of the specimen, parallel to the fiber direction. Results are presented for T300/5208 graphite-epoxy for fiber orientations of 10° , 30° , and 45° .

INTRODUCTION

The tensile strength of angle-ply laminates has been the subject of several previous papers primarily because it provides rather conclusive evidence of the detrimental influence of edge effects on strength for some fiber orientations. In addition, the angle-ply configuration is a basic component of many composite laminates and thus understanding its complete response, including failure, is of fundamental importance to the study of advanced fibrous composites.

As defined for this paper, angle-ply laminates are those made from an equal number of layers oriented at $+\theta$ and $-\theta$ to the loading direction (Fig. 1). Such laminates are balanced and we shall restrict our attention to symmetric lay-ups. Two configurations will be considered. Laminates of the form $[(\pm\theta)_2]_s$ will be referred to as alternating and $[+\theta_2/-\theta_2]_s$ laminates will be called clustered laminates. It should be noted that the thickness of a layer in the clustered configuration is double that in the alternating configuration. The in-plane elastic properties of such laminates are independent of stacking sequence. However, as will be shown in this paper, the strength and in particular the toughness, can vary significantly depending upon stacking sequence.

Apparently, the first investigation of the strength of angle-ply laminates was that of Lauraitis [1] in 1971. She recognized that interlaminar shear stresses initiate failure for small fiber angles and concluded that the strength of angle-ply laminates could be described in terms of Mode I and Mode II fracture toughness. The influence of edge effects was rather clearly demonstrated by Pipes, Kaminski and Pagano [2] in 1972. They reported that failure of a $[\pm 30]_s$ laminate is

initiated at the free edge as the result of high interlaminar shear strains, but that failure of a $[\pm 45]_s$ laminate is not sensitive to edge effects. Thus, they proposed two failure modes: the laminate mode, and the free-edge mode.

As part of a study on edge effects, Oplinger, Parker and Chiang [3] presented strength results for boron-epoxy and graphite-epoxy angle-ply laminates with fiber orientations of 10° , 30° and 45° . They considered stacking sequences of $[\theta_4/-\theta_3/\theta_4]$ and $[\pm\theta]_4$, referring to them as clustered and alternating, respectively. They reported that the strength of the alternating configuration was generally higher than the strength of the clustered configuration with the largest difference being for a 10° boron-epoxy laminate. Their graphite-epoxy results were less clear cut as to strength differences as a function of stacking sequence.

In 1975, Rotem and Hashin [4] identified three distinct modes of failure in E-glass/epoxy: one for reinforcement angles less than 45° , another for 45° , and a third for angles greater than 45° . They also pointed out that $\pm 45^\circ$ laminate was very ductile while other laminates tended to be brittle. They considered fiber orientations ranging from 30° to 60° in 5° increments. The exact stacking sequence of their laminates was not stated.

More recently Kim [5] attempted to correlate the tensor polynomial failure criterion with experimental data from tensile and compressive tests on angle-ply graphite-epoxy laminates. However, interlaminar stresses were totally ignored in the analysis and poor correlation between theory and experiment was obtained for small fiber angles. The

exact stacking sequence of the laminates was not stated.

The influence of interlaminar stresses on the prediction of initial failure using the tensor polynomial failure criterion was considered by this author and his colleagues in two previous papers [6,7] where it was shown that the interlaminar shear stress τ_{zx} dominates the initiation of failure in graphite-epoxy for fiber angles smaller than 37° .

Results for the influence of stacking sequence on the strength of $\pm 45^\circ$ carbon fiber, epoxy resin laminates were recently presented by Harrison and Bader [8]. They showed that there is a definite influence of stacking sequence with an alternating configuration exhibiting much higher strength than a clustered configuration. They also pointed out that failure of clustered specimens was catastrophic with no indication of damage prior to fracture. Their alternating laminates exhibited a progressive failure with considerable damage evident prior to complete fracture.

The relationship between engineering properties and delamination of finite-width graphite-epoxy laminates was recently studied by this author [9]. It was shown that there is a close correspondence between the mismatch in coefficient of mutual influence of adjacent layers and delamination of angle-ply laminates.

The purpose of this paper is to demonstrate the influence of layer thickness on the strength and toughness of finite-width graphite-epoxy angle-ply laminates under tensile loading, and to provide an explanation of the observed influence.

EXPERIMENTAL PROGRAM

Test Specimens

The specimens used in this investigation were fabricated from eight plies of T300/5208 graphite-epoxy. Tensile coupons nominally 12 mm wide and 25 cm long were cut from flat plates and tested in an axial loading machine under quasi-static conditions. After gripping, a 30 cm gage length remained. Strains were recorded with foil-type electrical resistance strain gages. Fiber orientations of 10°, 30°, and 45° were considered. The stacking sequence was either $[(\pm\theta_2)]_s$ (alternating) or $[\theta_2/-\theta_2]_s$ (clustered). Three duplicate tests were conducted for each specimen configuration.

RESULTS AND DISCUSSION

Strength and Toughness

The test results are summarized in Table 1 and Figs. 2-5. The elastic properties are independent of layer thickness and in agreement with lamination theory (allowing for small variability in specimens). However, the strength and toughness (area under the stress-strain curve) are dependent on stacking sequence. Typical stress-strain diagrams (Figs. 2-4) for the three fiber angles indicate that in each case the response is independent of stacking sequence prior to failure of the clustered laminate. The 10° and 30° clustered laminates exhibit essentially linear behavior with the 45° clustered laminate showing a small degree of nonlinearity. For the alternating layer configuration, the 10° specimens exhibit a small stiffening prior to failure which is

typical of unidirectional graphite-epoxy, the 30° specimens show essentially linear behavior to failure, and the 45° specimens exhibit increased nonlinearity as a result of the high shear influence at 45°.

The ultimate stress, ultimate strain and toughness results presented in Table 1 and Fig. 5 show significantly higher values for the alternating layer configuration. The ultimate stresses range from 25 to 49 percent higher, ultimate strains range from 43 to 75 percent higher and the toughness ranges from 74 to 167 percent higher, depending upon fiber orientation. For all three properties, the largest increase was found at $\theta = 30^\circ$. Since results were obtained for only three fiber orientations, the most that can be said concerning the orientation of largest increase that it is between 10° and 30° (Fig. 5).

Failure Mechanisms

In order to understand the failure mechanisms in these laminates, replicas [10] were taken of the free edges prior to and after fracture. For the clustered laminates, replicas were taken on a fourth specimen at numerous load levels prior to failure. The alternating laminates were replicated only after failure. No damage was observed in the clustered laminates prior to failure. Post failure edge replicas of the clustered laminates are shown in Figs. 6-8 and schematic representations of the fracture surfaces and damage zones of both laminate types are presented in Figs. 9 and 10. Failed specimens are pictured in Fig. 11.

Examination of post failure edge replicas and failed specimens indicates that the mode of failure is distinctly different for the two stacking sequences for fiber angles of 10 and 30 degrees. The mode of failure was essentially independent of stacking sequence for $\theta = 45^\circ$.

Failure of all clustered laminates was due entirely to matrix cracking and/or fiber matrix debonding with no fiber failure. The fracture surface of these laminates consisted of delaminations at the plus/minus interfaces and a distinct through-the-thickness crack across the width of each layer parallel to the fiber direction of that layer (Figs. 9 and 11). It should be noted that in the absence of fiber breakage, both the transverse cracks and the delaminations are necessary for complete fracture to occur.

Failure of the 10° and 30° alternating laminates differs significantly in that the fracture surface is basically a single crack across the width of the specimen parallel to the fiber direction of the outer layer. Thus failure in the outer layers and all other layers of the same orientation is matrix failure. Failure of the remaining layers is due to fiber breakage. Delamination of these two laminates was generally restricted to a small region on the free edges. When present, it occurred at each interface between plus and minus theta layers (Fig. 10). More delamination was present in the 10° specimen in which the mismatch in coefficient of mutual influence is largest [9]. The alternating 45° specimens failed in a mode similar to the clustered laminate (Fig. 11).

As shown in Figs. 6-11, the region of the damage zone was defined by a single crack extending across the width of the specimen parallel to the fiber direction. Transverse edge cracks are present in the damage zone. These additional edge cracks, which are more numerous for the 45° orientation, do not extend across the entire width of the specimen. As is evident in Figs. 6-8, the clustered specimens were essentially free

of cracks outside this damage zone. This was also basically true of the alternating laminates with the exception of the $[(\pm 45)_2]_5$ laminate which exhibited a few isolated crack regions away from the fracture surface.

It was not possible to observe the actual initiation of crack growth with the technique being used. However, a plausible scenario of failure events which is consistent with the final form of the fracture surface of the clustered laminates can be formulated. Delamination of these laminates is a direct result of the high interlaminar shear stress τ_{zx} at the free edge, between plies of differing fiber orientation. It has been shown previously [7,9] that these interlaminar shear stresses peak at approximately $\theta = 15^\circ$. If delamination over a small finite length is the first failure event, the remaining layers are loaded in a manner which is equivalent to unidirectional off-axis tensile testing. The shear coupling present under such loading conditions results in transverse and shear stresses in the material principal coordinates [11]. These stresses initiate the transverse cracks parallel to the fiber direction. Complete fracture occurs when the transverse crack has extended across the width of the specimen and the delamination has extended along the corresponding length and across the width of the specimen.

Thickness Effects

Increasing the thickness of individual layers has the effect of increasing the interlaminar shear stress τ_{zx} . This can be seen by consideration of the x force equilibrium of a unit length of half the specimen width above any plus/minus θ interface. This equation can be written

$$\sum_k \tau_{xy}^k \cdot t_k = \int_0^b \tau_{zx}(y) dy \quad (1)$$

where t is the layer thickness, b is the half-width and τ_{xy} is the stress obtained from laminate theory which is independent of stacking sequence. The integral can be expressed in terms of the maximum value of the interlaminar shear stress τ_{zx}^* , which occurs at the free edge, as

$$\tau_{zx}^* f(b) = \int_0^b \tau_{zx}(y) dy \quad (2)$$

The function $f(b)$ is a geometric parameter of the $\tau_{zx}(y)$ distribution curve. The interlaminar shear stress at the free edge can now be written

$$\tau_{zx}^* = \sum_k \frac{\tau_{xy}^k \cdot t_k}{f(b)} \quad (3)$$

where the summation is over all layers above the interface. Equation (3) clearly shows the dependence of τ_{zx}^* on layer thickness.

Fig. 12 shows a comparison of the distributions of the interlaminar shear forces per unit length (Eqn. 2) and the maximum interlaminar shear stresses τ_{zx}^* determined by finite elements for all six laminate configurations considered in this paper. The shear forces were obtained from the laminate theory and the finite element results were obtained with the program used in reference [6, 7 and 9]. The two quantities exhibit the same general form of distribution for all six laminates, but the shear force distribution does not predict the full extent of reversal in the

alternating configurations. The finite element results show that the elasticity solution is necessary to describe the complete character of stress distribution in the alternating laminates. The largest inter-laminar shear stresses always occur in the clustered laminates with the maximum shear stress in the cluster laminates being approximately 25 percent greater than those in the alternating laminates. These results support the argument that the clustered laminates fail at lower ultimate stresses due to delamination at the plus/minus θ interface.

CONCLUSIONS

It has been shown that the strength, toughness and mode of failure of finite width angle-ply laminates are dependent on layer thickness (stacking sequence) with an alternating plus/minus θ layer configuration providing significantly higher strength and toughness than a clustered layer configuration. The higher values for the alternating layer stacking sequence have been explained, with the aid of post-failure edge replicas and approximate stress analysis, to be the result of lower interlaminar shear stresses in the alternating layer configuration. The mode of failure in clustered laminates is entirely matrix failure with no fiber breakage. Two of the alternating laminates considered fail due to a combination of matrix failure and fiber breakage. The damage zone in both configurations is defined by a single crack extending across the width of the specimen, parallel to the fiber direction. Very little edge damage is present outside this region. No damage was observed prior to catastrophic failure. The results presented here indicate that clustered angle-ply laminates of 10° , 30° and 45° all fail due to edge effects.

Since the results shown in this paper are influenced by free edge effects, it is not expected that they would be present in tubular specimens.

ACKNOWLEDGEMENT

This work was supported by the NASA-Virginia Tech Composites Program NASA CA NCCI-15 and Society National Industrial Aerospatial (SNIAS) of France. Much of the work was completed while the author was on sabbatical at Ecole Polytechnique, Palaiseau, France. The author gratefully acknowledges the assistance of Z. Khosravi, M. Bourgeois, D. Theval, E. Klang, D. Wesley, and D. Danello with the experimental work.

REFERENCES

1. Lauraitis, K., "Failure Modes and Strength of Angle-Ply Laminates," UIIU-ENG 71-6009, T&AM Report #345, Univ. of Illinois, 1971.
2. Pipes, R. B., Kaminski, B. E., and Pagano, N. J., "Influence of the Free Edge upon the Strength of Angle-Ply Laminates," Analysis of the Test Methods for High Modulus Fibers and Composites, ASTM STP 521, Am. Soc. Testing and Materials, 1973, pp. 218-228.
3. Oplinger, D. W., Parker, B. S., and Chiang, F. P., "Edge-Effect Studies in Fiber-Reinforced Laminates," Experimental Mechanics, Vol. 14, No. 9, Sept. 1974, pp. 347-354.
4. Rotem, A. and Hashin, Z., "Failure Modes of Angle-Ply Laminates," J. Composite Materials, Vol. 9, April 1975, pp. 191-206.
5. Kim, R. Y., "On the Off-Axis and Angle-Ply Strength of Composites," Test Methods and Design Allowables for Fibrous Composites, ASTM STP 734, (C. C. Chamis, ed.) Am. Soc. Testing and Materials, 1981, pp. 91-108.
6. Herakovich, C. T., Nagarkar, A., and O'Brien, D. A., "Failure Analysis of Composite Laminates with Free Edges," Modern Developments in Composite Materials and Structures, (J. R. Vinson, ed.) ASME, 1979.
7. Herakovich, C. T. and Nagarkar, A., "On Failure Modes in Finite Width Angle-Ply Laminates," Advances in Composite Materials, (A. R. Bunsell et al., eds.) ICCM III, Pergamon Press, 1980.
8. Harrison, R. P. and Bader, M. G., "Damage Development in CFRP Laminates Under Monotonic and Cyclic Stressing," IV National and I International Meeting on Composite Materials, Milan, 19-21 Nov. 1980 (to be published in 1981 by Applied Science Publishers Ltd.)
9. Herakovich, C. T., "On the Relationship Between Engineering Properties and Delamination of Composite Materials," J. Composite Materials, Vol. 15, July 1981, pp. 336-348.
10. Stalnaker, D. O. and Stinchcomb, W. W., "Load History Edge Damage Studies in Two Quasi-Isotropic Graphite Epoxy Laminates," Composite Materials Testing and Design, ASTM STP 674, 1979, pp. 620-641.
11. Pagano, N.J. and Halpin, J. C., "Influence of End Constraints in the Testing of Anisotropic Bodies," J. Composite Materials, Vol. 2, No. 1, 1968, pp. 18-31.

Table 1

Test Results for T300/5208 Graphite-Epoxy

Laminate	σ_x^u (ksi)	ϵ_x^u (%)	ϵ_y^u (%)	E psi x 10 ⁶		Γ (ksi)
				Test	Theory	
[(±10) ₂] _s	115.26	0.69	-0.39	16.39	17.80	0.39
	112.32	0.69	-0.39	15.67	17.80	0.39
	122.39	0.72	-0.44	15.88	17.80	0.43
Averages	116.67	0.70	-0.41	15.98	17.80	0.40
[10 ₂ /-10 ₂] _s	85.18	0.47	---	17.86	17.80	0.20
	97.32	0.49	-0.30	19.52	17.80	0.24
	89.82	0.51	-0.31	17.46	17.80	0.23
Averages	90.77	0.49	-0.31	18.28	17.80	0.23
[(±30) ₂] _s	62.78	1.23	-1.90	6.99	7.30	0.44
	58.94	1.23	-1.80	6.71	7.30	0.40
	60.24	1.06	-1.54	7.07	7.30	0.35
Averages	60.65	1.17	-1.75	6.92	7.30	0.40
[30 ₂ /-30 ₂] _s	38.21	0.65	---	7.16	7.30	0.13
	42.70	0.68	-0.90	7.51	7.30	0.16
	41.37	0.69	-0.90	7.31	7.30	0.15
Averages	40.76	0.67	-0.90	7.33	7.30	0.15
[(±45) ₂] _s	24.71	1.64	-1.38	2.96	2.85	0.26
	24.53	1.48	-1.18	3.14	2.85	0.23
	23.89	1.61	-1.30	2.90	2.85	0.25
Averages	24.38	1.58	-1.29	3.00	2.85	0.25
[45 ₂ /-45 ₂] _s	19.32	1.03	---	2.80	2.85	0.12
	19.71	0.95	-0.69	2.99	2.85	0.11
	19.69	0.94	-0.69	3.62	2.85	0.11
Averages	19.57	0.97	-0.69	3.17	2.85	0.11

Γ - toughness (area under stress-strain curve)

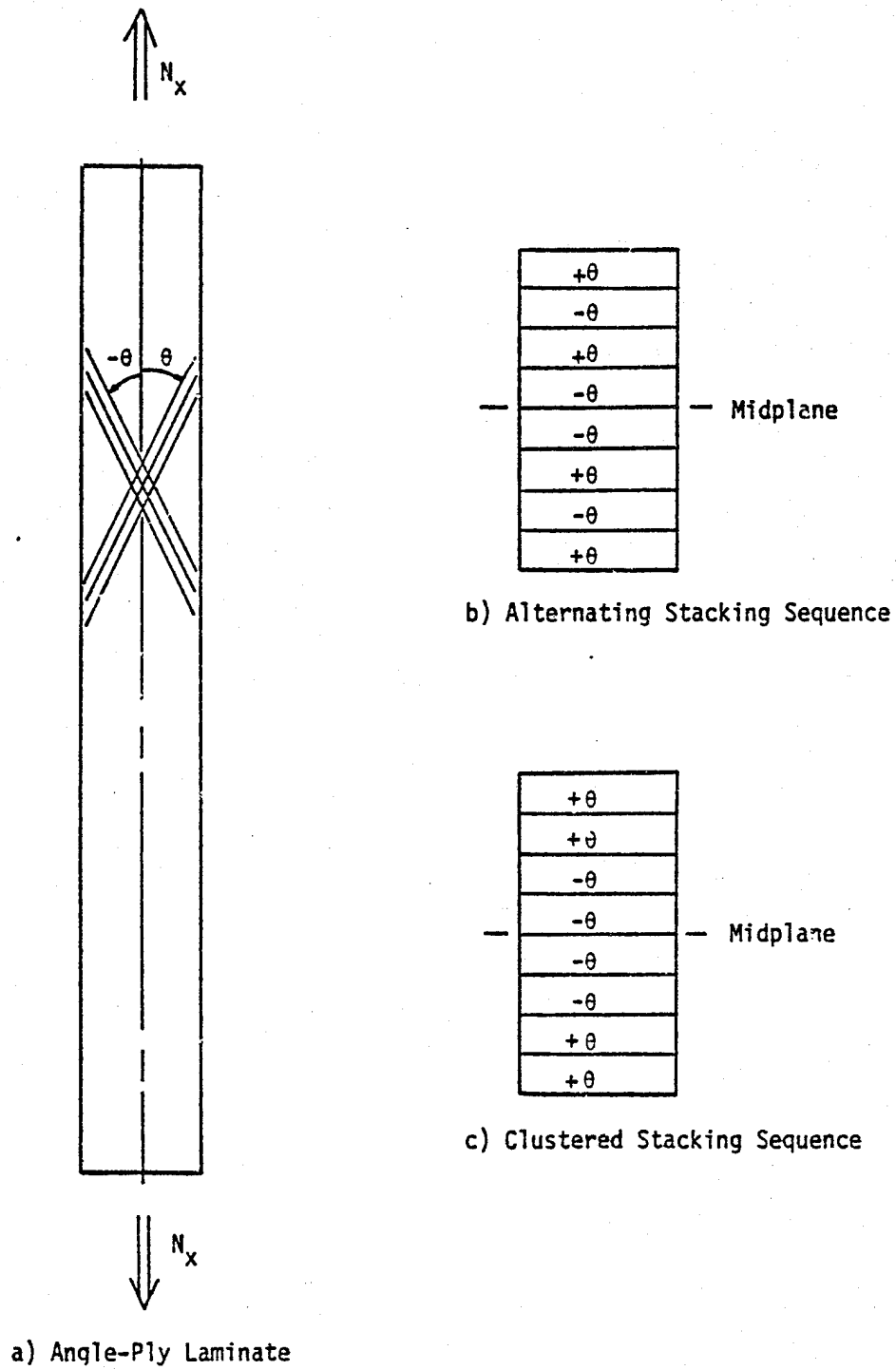

Figure 1 - Laminate Configurations

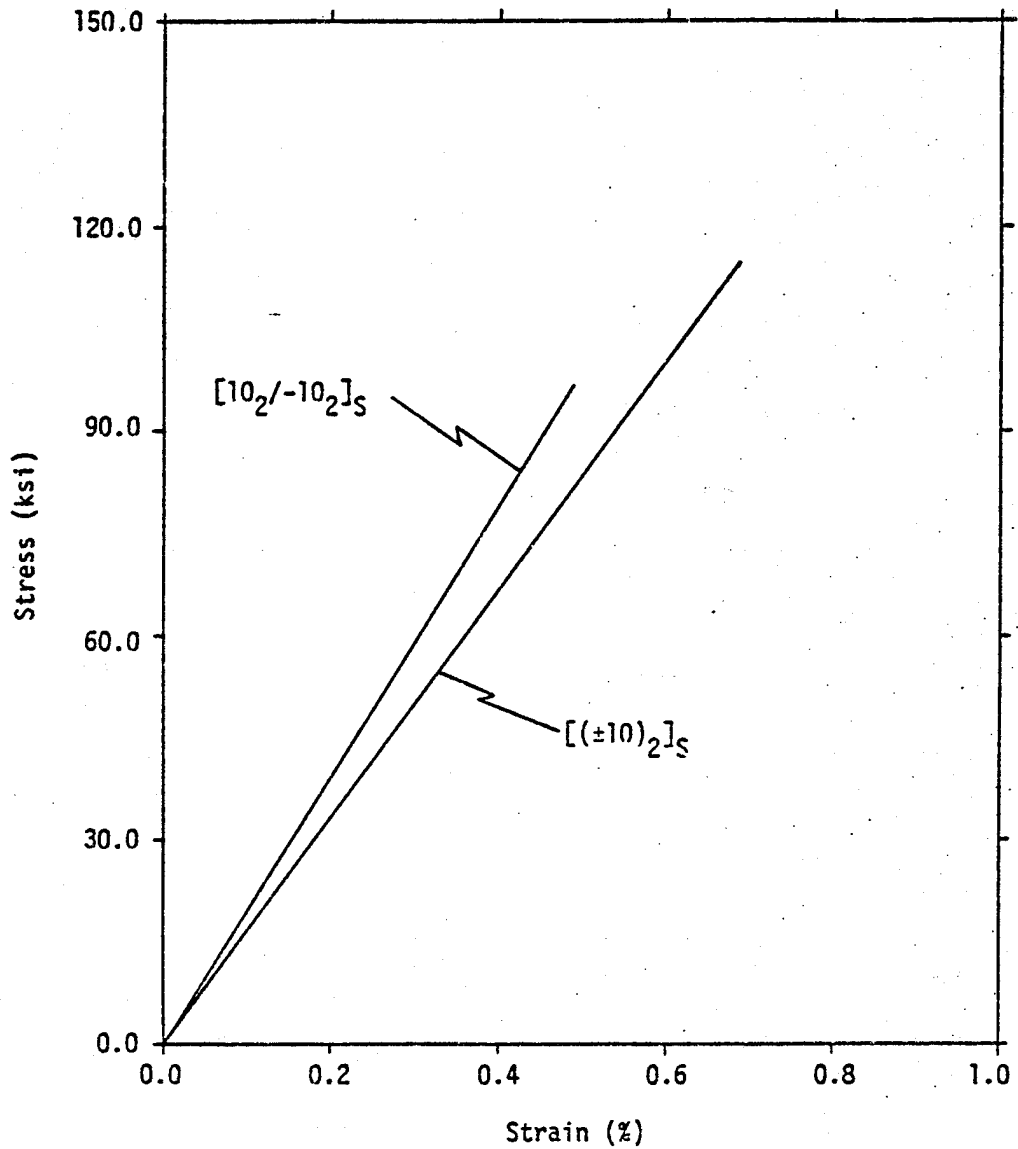

Fig. 2 Stress-Strain for $[10_2/-10_2]_S$ and $[(\pm 10)_2]_S$
T300/5208 Graphite Epoxy

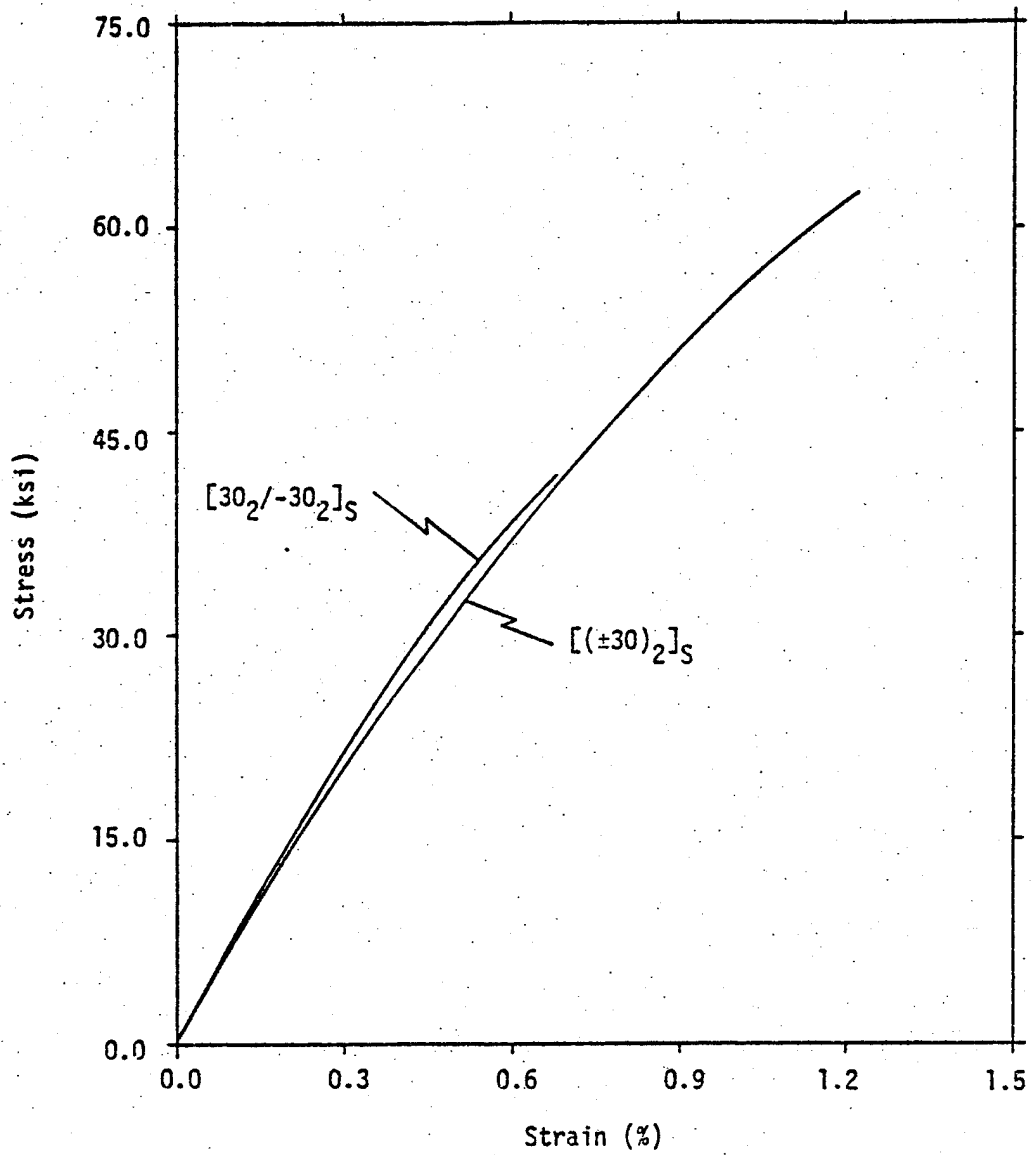

Fig. 3 Stress-Strain for $[30_2/-30_2]_S$ and $[(\pm 30)_2]_S$ T300/5208 Graphite-Epoxy

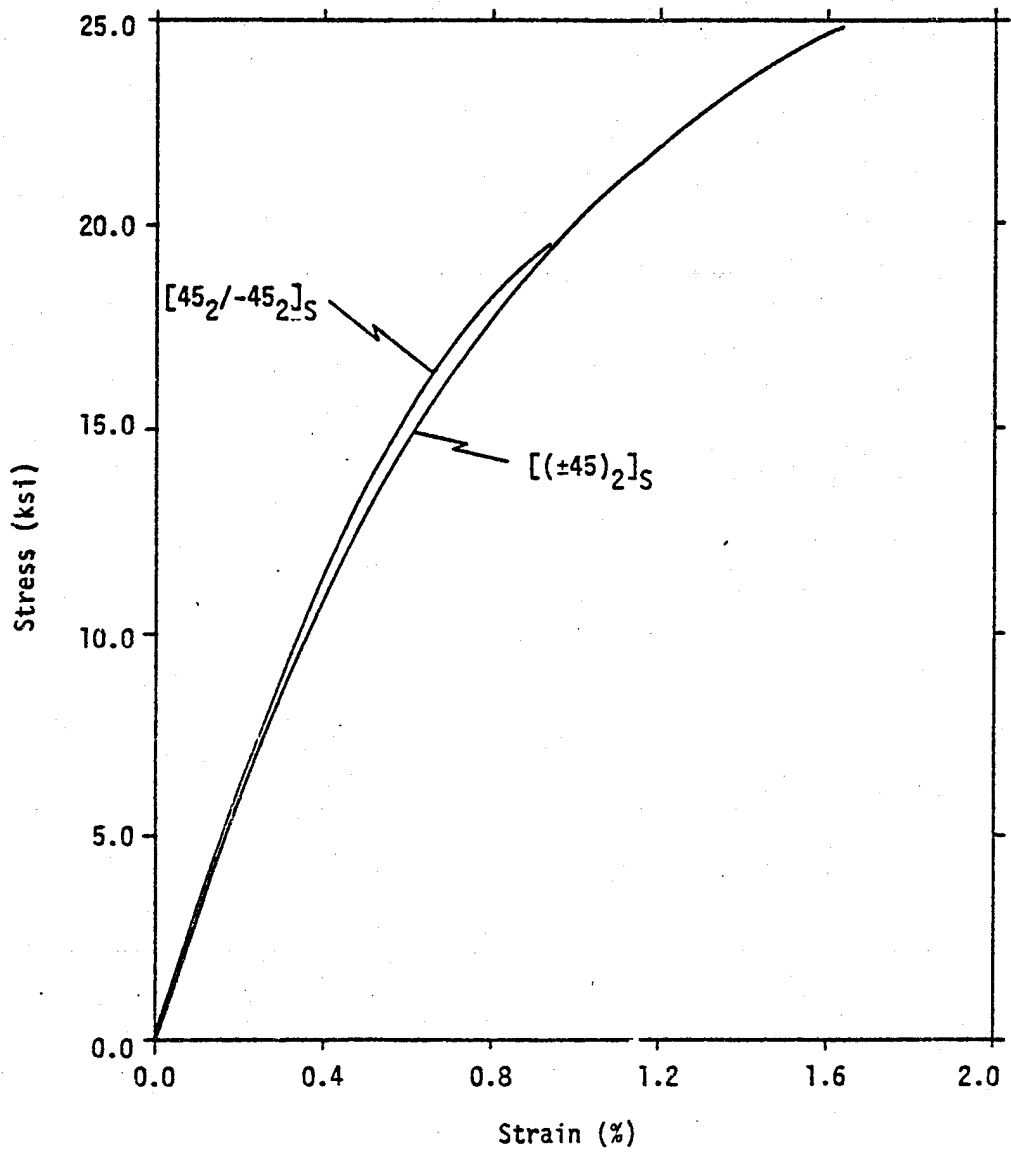

Fig. 4 Stress-Strain for $[45_2/-45_2]_S$ and $[(\pm 45)_2]_S$
T300/5208 Graphite Epoxy

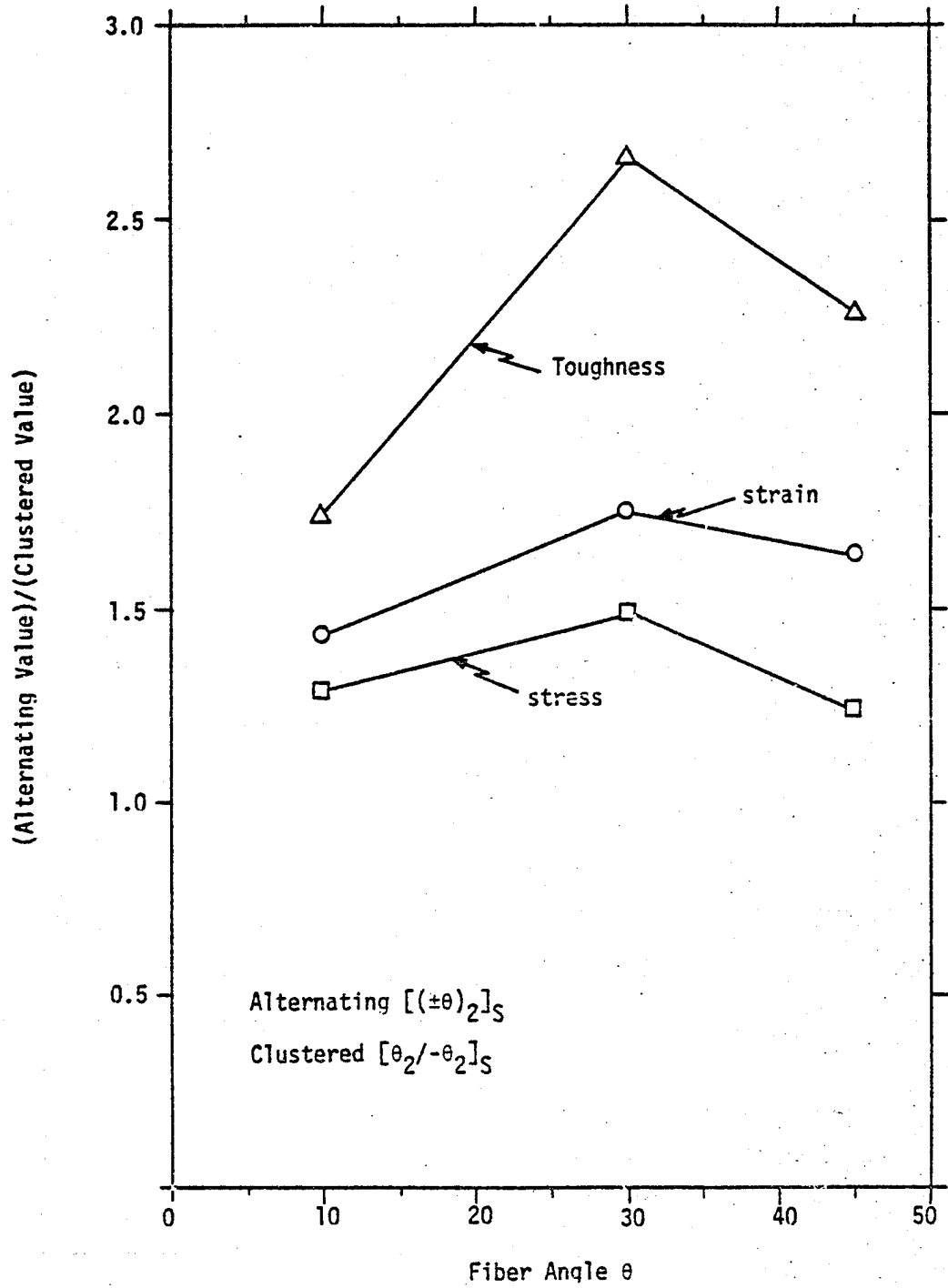
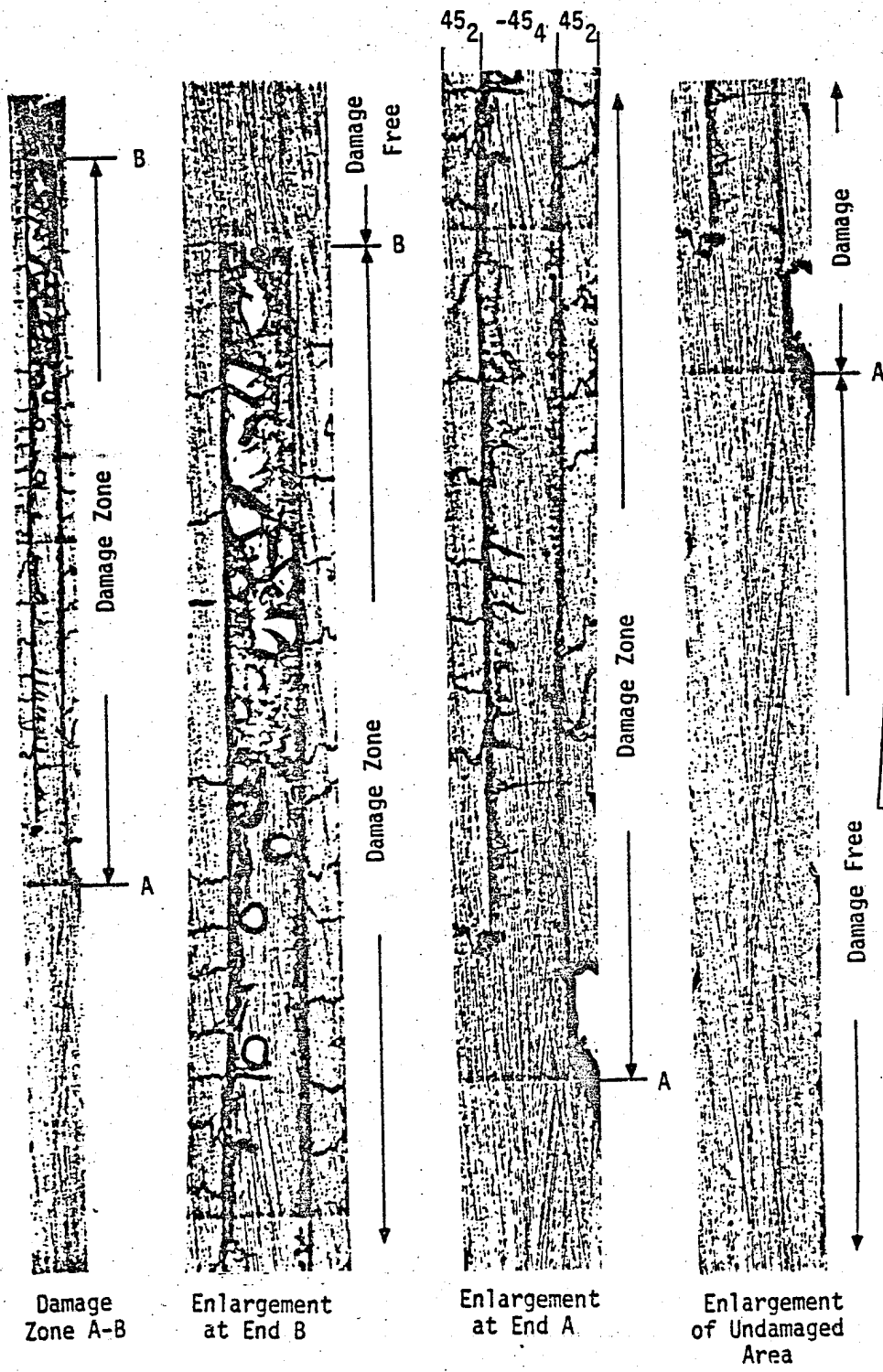

Fig. 5 Normalized Ultimate Stress, Ultimate Strain, and Toughness for T300/5208 Gr/Ep Angle-Ply Laminates



Reproduced from
best available copy.

Fig. 6 Post Failure Edge Damage in $[45_2/-45_4]_S$ T300/5208 Gr/Ep Tensile Coupon

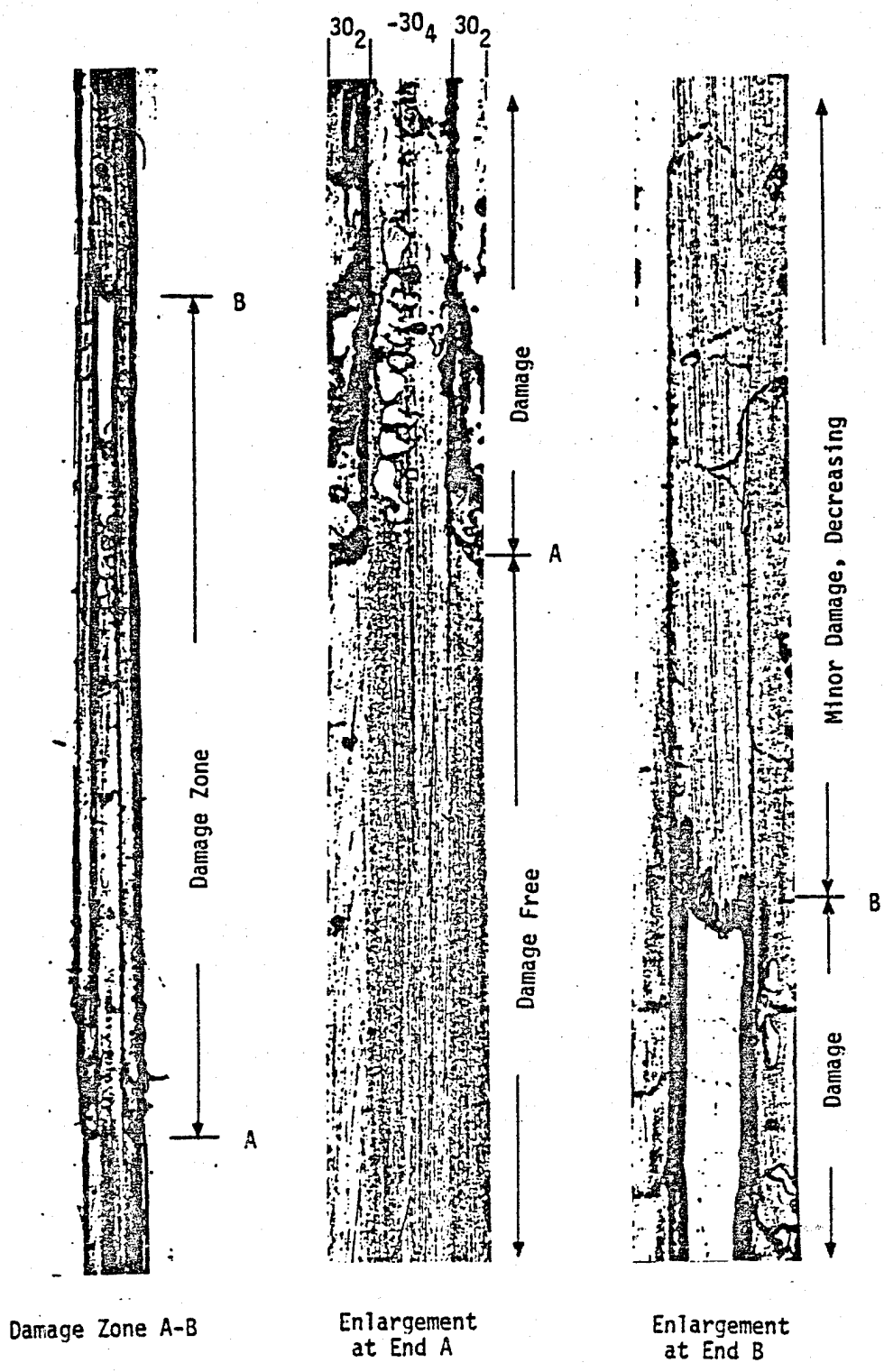
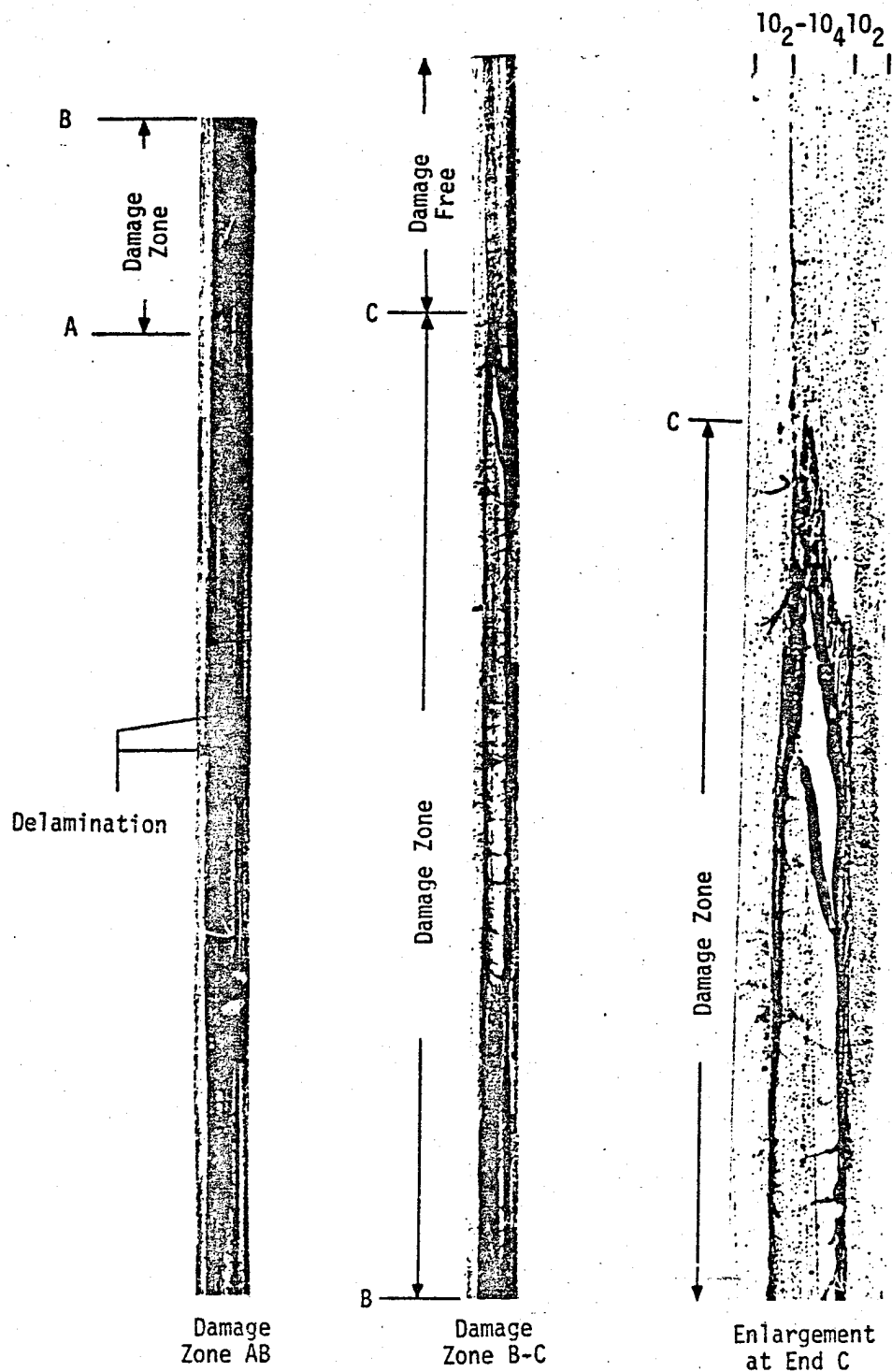

Fig. 7 Post Failure Edge Damage in [30₂/-30₂]_S T300/5208 Gr/Ep Tensile Coupon



Reproduced from
best available copy.

Fig. 8 Post Failure Edge Damage in $[10_2/-10_2]_5$ T300/5208 Gr/Ep Tensile Coupon

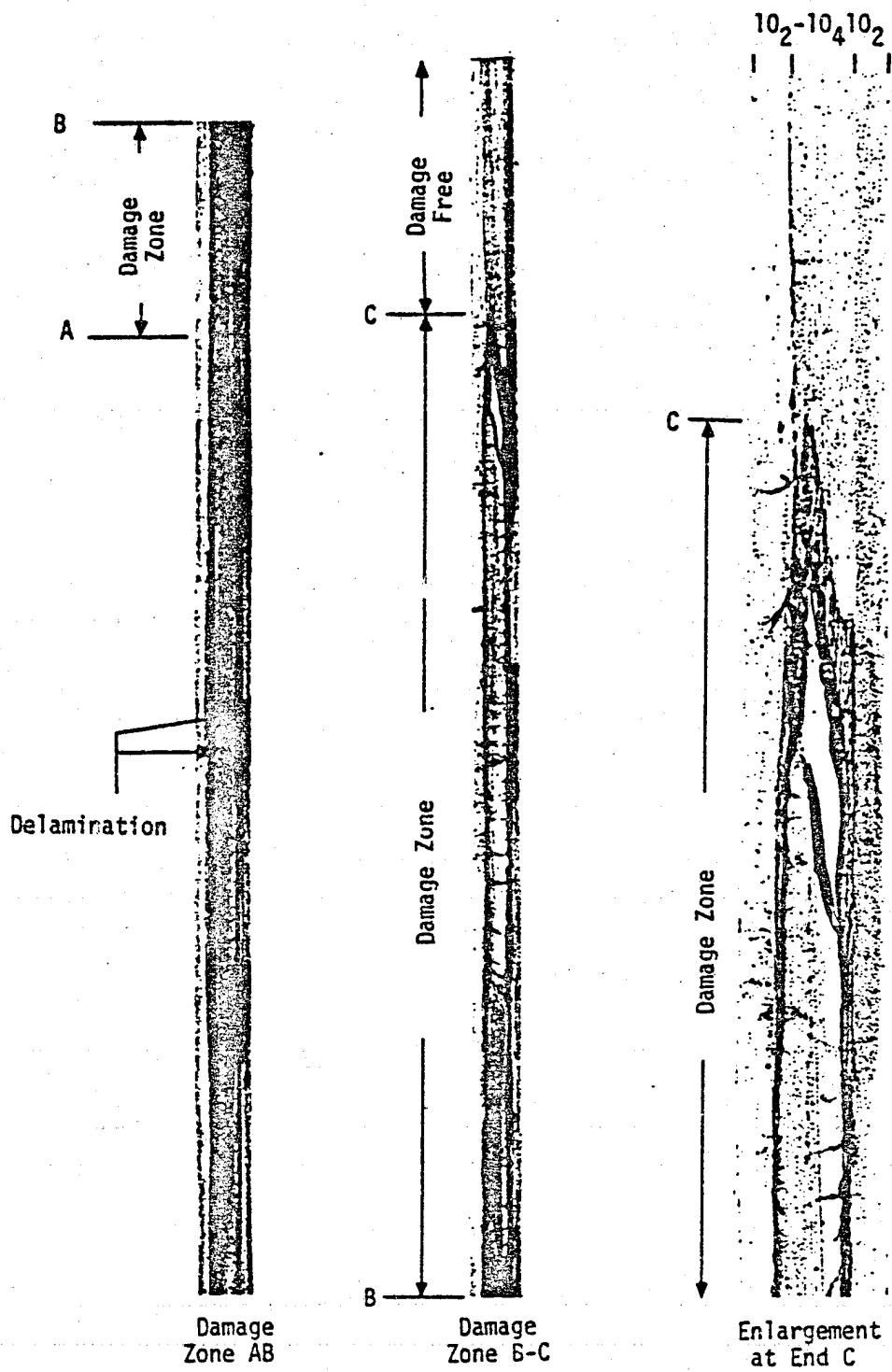

Fig. 8 Post Failure Edge Damage in $[10_2/-10_2]_S$ T300/5208 Gr/Ep Tensile Coupon

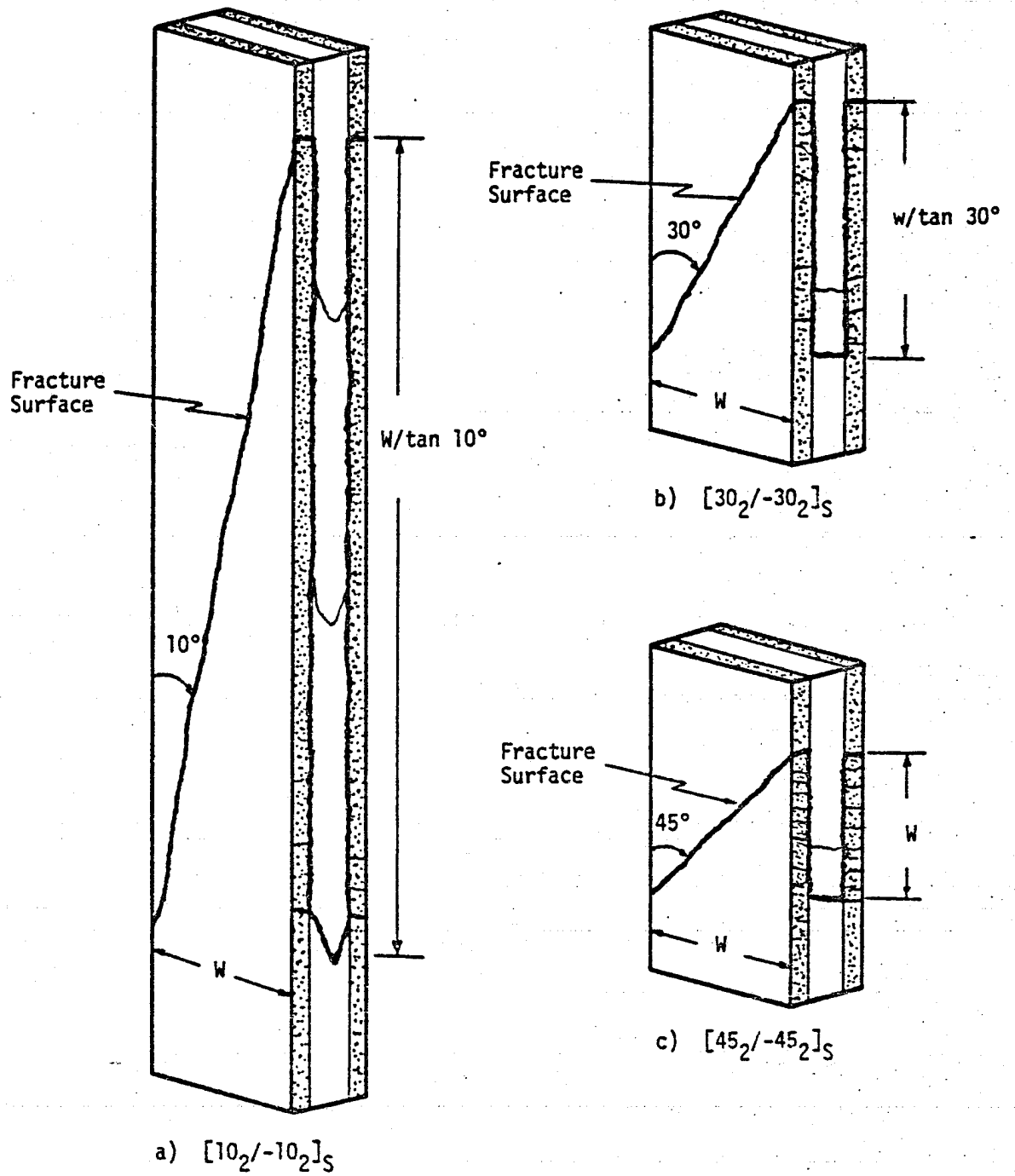

Fig. 9 Damage Zones in Clustered Angle-Ply Laminates

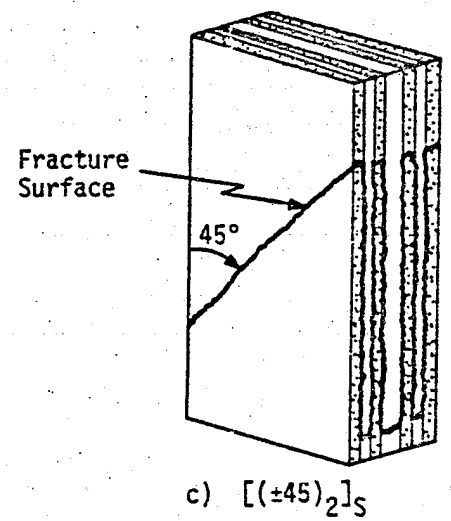
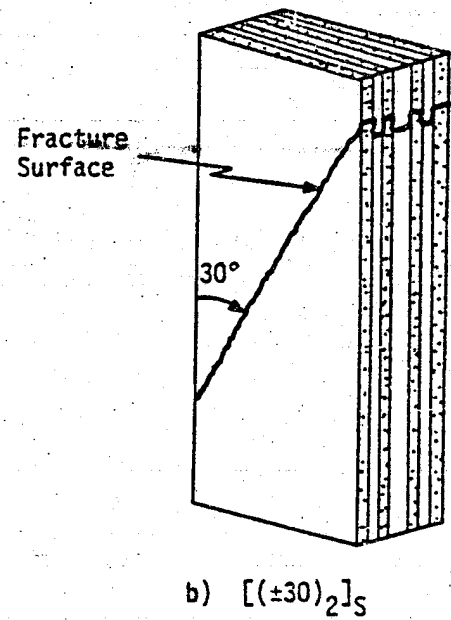
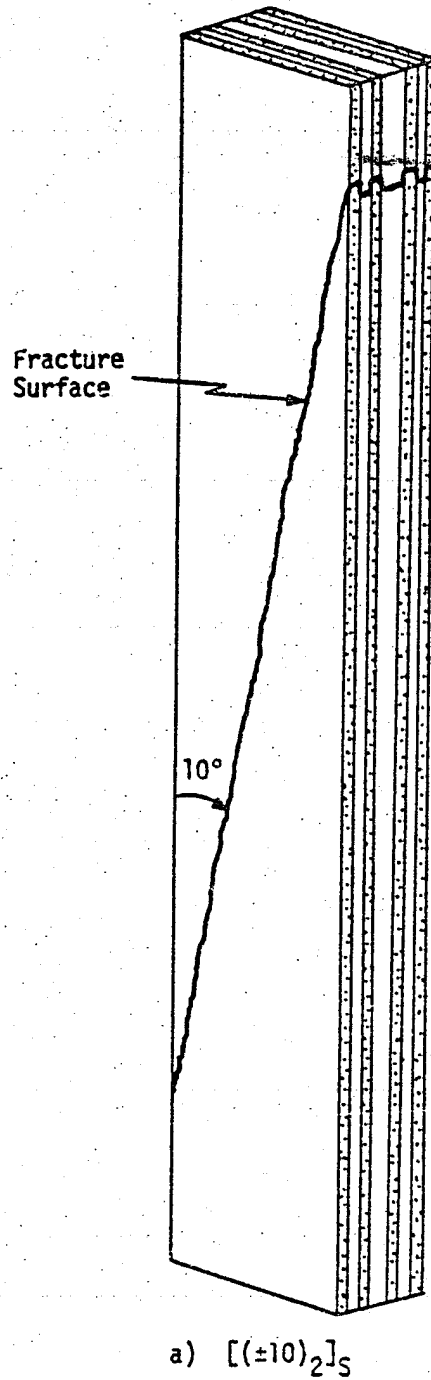
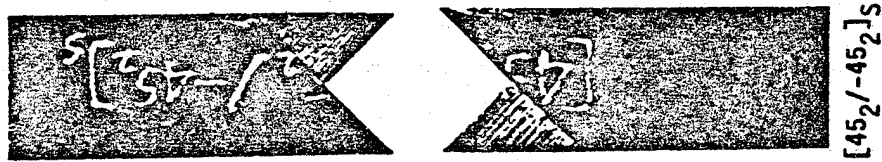
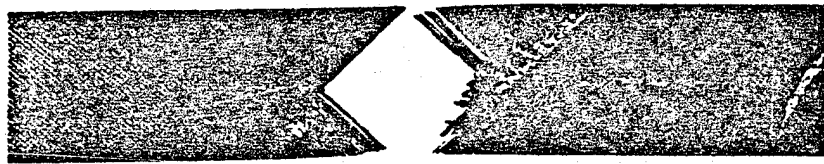

Fig. 10 Damage Zones in Alternating Angle-Ply Laminates



[45₂/-45₂]_S



[(+45)₂]_S

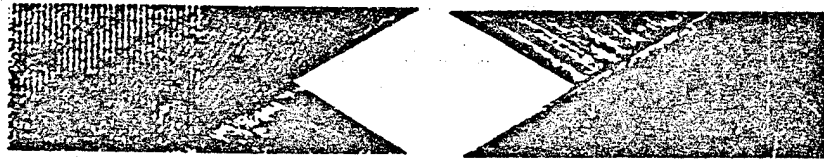

[30₂/-30₂]_S

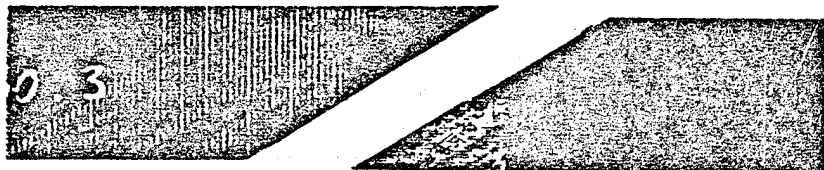

[(+30)₂]_S



[10₂/-10₂]_S



[(+10)₂]_S

Fig. 11 Failed Clustered and Alternating Layer Angle-Ply Laminates

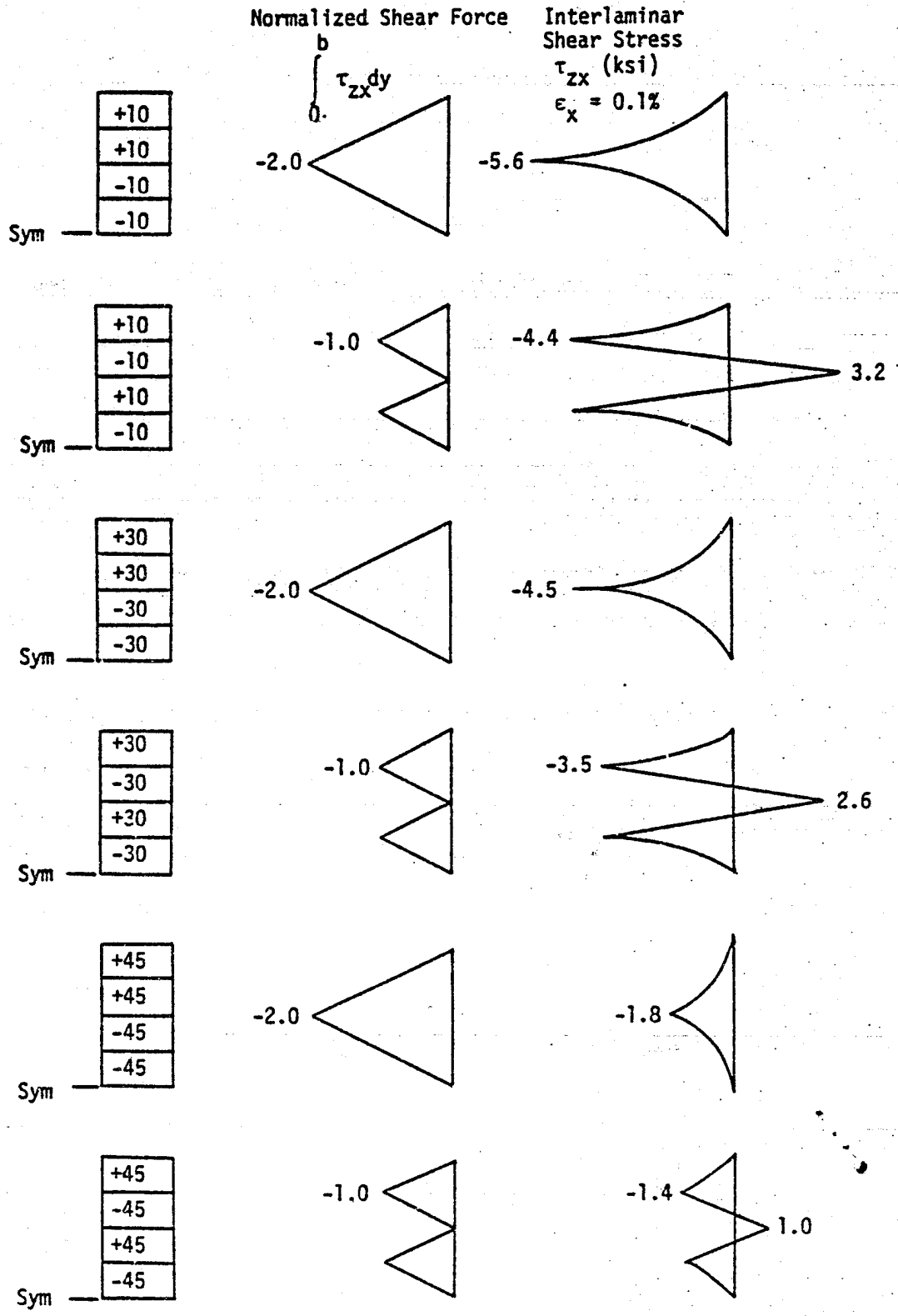

Fig. 12 Through-the-Thickness Interlaminar Shear Stress and Shear Force Distributions for Angle-Ply Laminates

END
DATE
FILMED
7-15-82
NTIS