

D121447

880 - 33491

# NASA Technical Memorandum 80219

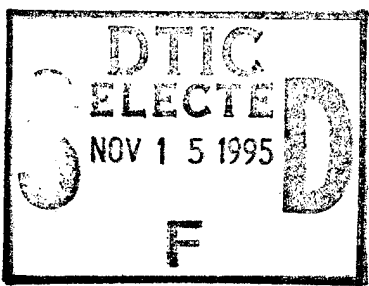

## ELECTRONIC EQUIPMENT VULNERABILITY TO FIRE-RELEASED CARBON FIBERS

RICHARD A. PRIDE, AUSTIN D. MCHATTON,  
AND KENNETH A. MUSSELMAN

DISTRIBUTION STATEMENT A  
Approved for public release  
Distribution Unlimited

SEPTEMBER 1980

19951113 101



National Aeronautics and  
Space Administration

Langley Research Center  
Hampton, Virginia 23665

DTIC QUALITY INSPECTED 8

DEPARTMENT OF DEFENSE  
PLASTICS TECHNICAL EVALUATION CENTER  
ARRADCOM, DOVER, N. J. 07800

PLASTED 39134

ELECTRONIC EQUIPMENT VULNERABILITY TO FIRE-RELEASED  
CARBON FIBERS

By Richard A. Pride and Austin D. McHatton  
NASA-Langley Research Center

and

Kenneth A. Musselman  
U.S. Naval Surface Weapons Center, Dahlgren Laboratory

SUMMARY

The vulnerability of electronic equipment to damage by carbon fibers released from burning aircraft type structural composite materials was investigated in the shock tube facility at the U.S. Naval Surface Weapons Center, Dahlgren, Virginia. Tests were conducted on commercially available stereo power amplifiers which showed that the equipment was damaged by fire-released carbon fibers but not by the composite resin residue, soot and products of combustion of the fuel associated with burning the carbon fiber composites. The limited testing indicated that the failure rates of the equipment exposed to the fire-released fiber were consistent with predictions based on tests using virgin fibers.

INTRODUCTION

Carbon fibers have high strength and stiffness and are lightweight, making them very attractive for use in composite structures. The fibers also have high electrical conductivity such that when free carbon fibers settle on electrical conductors, they can cause equipment malfunctions or damage from short circuiting. As long as the fibers are embedded in the matrix of a composite material, they pose no hazard. However, when the composite is burned, as may occur in an aircraft crash-fire accident, fibers can be released from the matrix, become airborne, and be disseminated over large areas, creating a potential hazard to electrical and electronic equipment. The Graphite Fibers Risk Analysis Program Office at Langley Research Center has been charged with assessing the risk associated with such an accidental release of carbon fiber.

Vulnerability of electrical and electronic equipment to carbon fibers was established by testing approximately 150 individual items which were representative of homeowner's appliances, business and industrial equipment, aircraft avionics, and generic electrical and electronic circuits (ref. 1). Many of these tests were conducted in a closed chamber into which chopped virgin fibers were blown. Equipment was exposed until failure or until a fiber ex-

DTIC-AE  
lti  
11-2-95  
ies

Special  
A-1

posure of  $10^8$  fiber seconds/meter<sup>3</sup> was achieved, at which exposure the equipment was considered invulnerable. It was not clear how these failures would compare to failures of similar equipment exposed to the fire-released carbon fibers and sooty effluent from an aviation jet fuel fire burning carbon fiber composite structure. Therefore, the test program described herein was planned for exposing electronic devices to fire-released fibers.

The purpose of the test program was to determine the vulnerability of electronic equipment to damage by carbon fibers released from burning aircraft-type structural composite materials and to establish a correlation between the failure rates resulting from exposure to the fire-released fibers and failure rates resulting from exposure to virgin fibers. The approach consisted of burning typical aircraft-type structural composite materials in small-scale simulations of aircraft crash fires, and exposing representative electronics equipment to the carbon fibers released from the burning composite. Design calculations indicated the necessity for keeping the fire, the burning composite and the released fibers all inside some sort of chamber or confined space in order to get an exposure large enough to expect failures in electronic equipment. A search for such a facility identified a large steel tubular structure at the U.S. Naval Surface Weapons Center, Dahlgren, Virginia, which had previously been used for shock wave propagation studies, but was currently idle. Carbon-fiber-epoxy composite specimens representative of aircraft components were obtained from NASA-Langley structural research and development programs and were burned in aviation jet-fuel fires in the shock tube to generate a source of airborne single fibers. This shock tube was large enough so that the fire-released carbon fibers, combustion products, and heated air could be transported to a cooler region where the electronic equipment was exposed. Instrumentation was developed and installed to measure temperature and velocities and to sample the air stream for carbon fibers.

After a lengthy series of developmental tests, techniques were developed which resulted in the release of a sufficient quantity of carbon fibers to provide fiber exposures in the test region comparable to those used in the closed chamber testing with virgin fibers. Six pieces of identical electronics equipment were placed in the shock tube and operated in the fire-released carbon fiber environment until failures occurred. Comparisons were made with the failures of similar equipment in the chamber tests with virgin fibers. The fire-released fibers were characterized by their length spectrum, their fire-reduced diameters and their increased electrical resistance.

Use of trade names or names of manufacturers in this report does not constitute an official endorsement of such products or manufacturers, either expressed or implied, by the National Aeronautics and Space Administration.

## SYMBOLS

D	fiber deposition, $f/m^2$
E	fiber exposure, $f \cdot s/m^3$
$\bar{E}$	mean exposure to failure for equipment, $f \cdot s/m^3$
f	number of fibers

## TEST FACILITY

The conical shock tube facility at the U.S. Naval Surface Weapons Center, Dahlgren, Virginia, was originally designed and utilized as a large-scale, explosive-driven conical shock tube simulator of nuclear air blasts. It had not been used for several years, and was made available for the fire-released carbon fiber tests. Figure 1 is an aerial photograph of the 750-m-long facility. The principal physical characteristics of the portions used for the fire tests are shown schematically in figure 2. Only the larger diameter, 366-m-long portion of the shock tube was used. The conical section increased in diameter at a uniform rate of one meter per 100 meters of axial length. The shell was constructed in sections varying generally from 20 to 30 m in length, and from 10 to 20 mm in thickness. Welded steel construction was used throughout resulting in a generally smooth interior surface which reduced the cleanup effort needed after each fire test. At the air inlet (fig. 2) a three-meter long bolted section of the tube was removed to allow air to be drawn freely into the fire region. Exhaust fans at the large end of the tube drew combustion products, heated air, and carbon fibers from the fire region past the test section, where the electronic devices were located.

The fire unit was a welded steel pan, 2.4 m square by 0.23 m deep (fig. 3) located inside the shock tube at the fire region. Initial attempts to maintain a uniform combustion of JP-1 aviation jet fuel over the surface of this pan were unsuccessful, and a smaller pan, 1.2 m square by 0.15 m deep, was constructed inside the larger pan. Jet fuel was pumped into the center of the pan through an opening in the bottom. The four pipes running diagonally towards the center from the corners of the larger pan (fig. 3) were connected to a separate fuel source and provided a means for getting a thin layer of gasoline initially on top of the jet fuel to enhance ignition. Thermocouples to survey the fire plume temperatures were mounted in the multi-tubular structure visible in the background in figure 3.

Fifty-four fire tests were conducted to develop equipment and validate techniques for producing the high fiber releases required for the electronic equipment tests. The equipment which finally evolved in the fire region is shown in figure 4. A three-



sided radiative chimney was added around the 1.2 m square fire pan to prevent the flames being severely deflected downwind. A gap between the chimney and the fire pan allowed sufficient combustion air to flow over the surface of the jet fuel. The remainder of the fresh air being drawn through the shock tube passed on either side or over the top of the chimney, mixing with the hot plume as it moved downwind.

A rotating basket (fig. 5), 41 cm diameter by 46 cm long, mounted on a horizontal shaft, tumbled multiple pieces of composite material in the fire during the test. Five revolutions per minute was established as near-optimum tumbling speed through several fire tests. The shaft and basket were driven by a variable speed electric motor through a reduction gear and chain-and-sprocket drive (fig. 4(c)). Water cooling was provided to the shaft by a recirculating pump using water from the bottom of the fire pan.

Both fire pans were filled with approximately 12 cm depth of water and the JP-1 aviation jet fuel was then pumped into the 1.2 m square pan and floated on the surface of the water. Fuel pumping was maintained at a rate just sufficient for a steady burn. The jet fuel was pre-heated to 38°C to enhance its rate of vaporization and subsequent combustion. The water depth in the bottom of the fire pans was maintained through a redundant float-controlled fill-and-stop system.

The movie camera shown just downwind from the fire (fig. 4) was remotely controlled and permitted documentation of intermittent portions of the total test. The canister collector shown near the top of the shock tube, 5 m downwind, sampled the hot plume for carbon fibers, and will be discussed in the instrumentation section following.

A test control center (fig. 6) was located on the outside of the shock tube at the fire region. Jet fuel and gasoline pumping rates, ignition switches, water supply, and basket rotation were controlled from this station. Fire temperature was monitored by two thermocouples located alongside the specimen basket. A viewport was located in the side wall of the shock tube adjacent to the control center to allow visual observation of the fire for additional control.

A cooling water sprinkler system was provided with standard overhead fire sprinkler water spray heads over the top of the shell, extending approximately 20 m downwind from the fire region, to cool the shell and prevent warping.

The test section (fig. 7) was located 212 m downwind of the fire. The flat platform built into the bottom of the tube was large enough to provide mounting space for several types of carbon fiber instrumentation and the electronic equipment which

was exposed for vulnerability testing. The test section was far enough downwind from the fire for the hot plume to cool sufficiently to avoid overheating the exposed electronic equipment. A water scrubber was installed (figs. 8 and 9) farther downwind, 22 m from the test section. It consisted of a firefighting fog nozzle mounted on scaffolding inside the shock tube in an orientation that provided complete scrubbing of the soot and fiber cloud as it was drawn through this section. The scrubber was supplied through a 10 cm diameter fire hose connected to a high pressure pump adjacent to a nearby fire hydrant. Output of the scrubber was 3000 liters per minute of water at a line pressure of 700 kPa (800 gallons/minute at 100 psi). The scrubber water was collected on the floor of the shock tube between bulkheads (fig. 10). Intermediate baffles skimmed soot and carbon fibers from the water prior to draining out of the bottom of the tube.

Six 1.22 m-diameter exhaust fans were located in a bulkhead downwind from the scrubber near the large end of the shock tube (fig. 11). Each fan had a maximum capacity for moving air of  $9.4 \text{ m}^3/\text{s}$ , and each fan was driven by a variable-speed electric motor. A door in the bulkhead provided the principal means for access to the test section.

#### CARBON FIBER SAMPLING INSTRUMENTATION

This section describes the instrumentation employed for sampling the carbon fibers released during the facility development testing and during the electronic equipment exposure testing. The instrumentation was used to characterize the length and diameter spectra of the carbon fibers released from the burning composite and to estimate the level of carbon fiber exposure of the electronic equipment during the tests. The carbon fiber sampling instrumentation included the following:

- Sticky paper deposition samplers
- Sticky cylinder exposure samplers
- Canister collectors
- Charged grid detectors
- Light emitting diode (LED) detectors
- Millipore filter samplers

A description of each of these instrumentation devices follows.

#### Sticky Paper Deposition Samplers

Clear, adhesive coated polyester film, 0.05 mm thick by 35 mm square was employed for sampling fiber deposition in the shock tube. Fibers falling from the plume attach to the adhesive on the sampler. These samplers were laid on the bottom of the shock tube, three to a cross section, at approximately 13.5 m intervals between the fire pan and the test section as shown in figure 12.

Samplers were placed on 10 cm square wooden blocks (fig. 13) to assist in locating them inside the tube, and also to minimize post test contamination from fibers sliding along the steel shock tube surface. The samplers were individually collected after a test and placed adhesive side down on a 35 mm aperture card, as shown in figure 14. The samplers were then examined under a microscope where fibers were counted and measured (ref. 2 discusses the methodology) for length and diameter to provide fiber deposition and spectra information. Fiber exposure values were calculated from the depositions by dividing fiber deposition by the velocity at which the fiber was deposited. For the deposition samplers on the floor of the shock tube, fiber velocity was assumed to be the free-fall velocity, 0.02 m/s.

### Sticky Cylinder Exposure Samplers

These samplers were made of the same type and size material as the sticky paper samplers except the 35 mm squares were formed into a 10 mm diameter right circular cylinder. The 35 mm squares were wrapped on a mandrel, sticky side out, and joined by the adhesive at the overlapping edges. The cylinders were attached by the adhesive to wire holders as shown in figure 15. Figure 16 shows a typical sticky cylinder installation to sample for a vertical profile of fiber exposure in the test section. The cylinders were collected after the test, cut with scissors along the overlapping joint and laid out flat, adhesive side down on 35 mm aperture cards. The fibers were measured and counted in the same manner as for the sticky paper samplers. The number of fibers collected on the sticky cylinders was directly related to the fiber exposure through a calibration constant,  $2 \times 10^3$  s/m<sup>3</sup>, as determined in reference 3, for cylinders mounted with their longitudinal axis perpendicular to the direction of air flow.

Sticky cylinder samplers were located in several places on or near the floor of the test section (fig. 17). Four trees of sticky cylinders were also located in the test section (figs. 18 a, b, and c) to measure fiber exposure as a function of height above the floor at several locations. Three sticky cylinders were located on the stand alongside the prototype model of the charged grid detector (fig. 18 (d)) for comparison of fiber exposures.

In addition to the fixed sticky samplers which were in place for the duration of the test, sets of three sticky cylinder samplers were interchanged manually through the top of the test section on 15 minute intervals (fig. 18 (a) and (e)). The system of interchangeable samplers was developed as a consequence of suspected soot and/or moisture saturation of the fixed samplers after approximately 20 minutes of exposure to the products of combustion.

Locations of several other types of instrumentation and the test articles are also shown in figure 18. These are discussed in the following sections.

## Canister Collectors

The canister collector was a passive, trap-like sampler (fig. 19) designed to provide isokinetic sampling of the flow stream. It was a smaller adaptation of the collector designed by the U.S. Army Dugway Proving Ground, reference 4, for plume sampling just beyond the visible flames in large outdoor pool fires. The Dahlgren shock tube model used a cylindrical screen of woven wire mesh, (0.23 mm diameter wires spaced 1.46 mm on centers) contained within an outer shell of either cardboard or stainless steel. The stainless steel collector was used for sampling just beyond the visible flame. The area of the entrapment screen is considerably greater than the area of the entrance to the collector thus minimizing the soot saturation problem common to the sticky and other types of passive samplers. Samplers were located in the test section (figs. 18 (c) and (d)) and in the region of the fire (fig. 4).

The canister collector shown in figure 19 was calibrated in the NASA-LaRC free-flight wind tunnel at air speeds up to 18 m/s and at angles of attack up to 20°. Results are shown in figure 20 and indicate an air sampling efficiency slightly less than isokinetic and non-linear at the higher velocities. Angles of attack up to 10° do not appear to have any effect on sampling efficiency.

After each test the canister screens were taken apart and the surfaces were air-washed into a container equipped with a mesh filter and a vacuum line (ref. 4). Test residue was collected on the mesh filter, transferred to a sticky paper approximately 10 cm square, and examined under a microscope for carbon fibers.

## Charged Grid Detectors

Two models of a charged grid detector were installed in the test section as shown in figure 18 (d). A prototype model (fig. 21) had been built for a test chamber at Langley to consume stray carbon fibers that might be accidentally released into the laboratory environment. This unit had a 0.24 m × 0.17 m wire grid constructed by winding a pair of wires spaced 2 mm apart around insulated end posts. The wires were wound on the posts with a 2 mm pitch. Electrical charge on the adjacent wires of the grid was maintained at approximately 1000 volts by a capacitor. Carbon fibers shorting between two adjacent wires in the grid were vaporized by the capacitor discharge current. A strip-chart recorder was connected into the circuit to provide a time history of the capacitor discharges. The discharges were counted as carbon fiber intercepts on the grid.

Calibration of the prototype charged grid detector system in

a jet fuel fire sooty smoke plume indicated the necessity of reducing the grid operating voltage to about 250 volts in order to eliminate discharges due to soot buildup. 250 volts was sufficient to burn out single carbon fibers, however, a clump of fibers deposited on the grid could only be burned out by momentarily increasing the voltage to the 1000 volt level and then returning to the normal operational voltage.

An improved version of the charged wire grid detector, model 1, (fig. 22) was designed to count fiber intercepts, and also to make in-situ measurements of fire-released carbon fiber resistance, reference 3. The grid consisted of a wire comb assembly made of a number of parallel steel wires spaced 2 mm apart. The wires were electrically connected so that voltage existed between any two adjacent wires. Fibers contacting or falling across adjacent wires provided a short circuit path. Current and voltage measurements to fiber burnout could be used to determine fiber resistances. Fiber intercept time history data could be obtained by switching in a counter circuit in lieu of the resistance measuring circuit.

Calibration of the model 1 charged grid detector in the fiber test chamber at NASA-LaRC (ref. 3) indicated a counting efficiency of 70 percent for fibers with lengths greater than 2 mm. Fibers less than 2 mm long passed through the grid without being detected.

#### Light Emitting Diode Detectors

This device is an interrupted light beam type detector. Fibers passing through a light beam cause partial or total obscuration of the beam. The output signal from a detector upon which the beam is focused, is processed for counting the number of obscurations greater than preset levels. By relating fiber size to degree of obscuration, an indication of the number of fibers exceeding a given size (or equivalent length) passing through the beam can be obtained.

The instruments used in the shock tube tests (fig. 23) employed a light emitting diode light beam source and a silicon detector. Two instruments with slightly different electronic circuitry were used, one had a capability for counting fibers equal to and greater than 2 mm long, and the other had a capability for counting fibers equal to and greater than 4 mm long. Time history fiber count data was obtained with these detectors.

The light emitting detectors were developed for use in the NASA outdoor fire-released fiber tests conducted at Dugway Proving Ground, Utah. Reference 5 more fully describes the detectors

and their calibration.

### Millipore Filter Samplers

These samplers (fig. 24) are a type used by the National Institute of Occupational Safety and Health for collecting particles in the respirable size range (1 to 10 micrometers principal dimension). They employ a 0.8 micrometer pore size millipore filter connected to the inlet of a 2 liter per minute Mine Safety Appliance Company portable pump.

Samples were taken in the region of the shock tube test section to determine the presence of respirable carbon fibers in the fire plume. Samples were also taken at the discharge end of the facility to assess the effectiveness of the plume water scrubber.

### Other Instrumentation

Several other instruments were used in the shock tube test series which were not carbon fiber sensors. Chromal-alumel thermocouples were installed in the shock tube to measure temperatures. Two were in the fire region, one on each end of the rotating basket (fig. 4), and eight were installed at various heights on one of the sticky cylinder trees in the test section (fig. 18).

A propellor anemometer (fig. 18 (d)) was installed in the test section to measure air velocity during the test.

### TEST ARTICLE

The test article was a two-channel stereo power amplifier employing silicon semiconductors and conventional printed circuit boards (fig. 25). This device was chosen for testing because it was considered representative of electrical/electronic equipment having greatest vulnerability to damage by carbon fibers. The amplifier employed both unprotected printed circuits and unfiltered fan cooling and was among the most vulnerable items tested in the virgin fiber exposure tests (ref. 1).

## TEST RESULTS AND DISCUSSION

Fifty-four JP-1 aviation jet fuel fire tests were conducted to develop equipment and validate techniques for producing the high fiber releases required for the electronic equipment tests. No composite was burned in the first 25 tests which were performed to develop a region in the flames of the fire with temperatures from 900 to 1000°C. These temperatures were in the range of those expected around an aircraft structure in the midst of a large crash-and-burn pool fire (ref. 1). Operations with two of the six exhaust fans (fig. 11) running at full capacity produced the most uniform combustion conditions in the fire pan. This also created air velocity through the center of the test section of 0.67 m/s.

### Fire-Released Carbon Fiber Tests

Carbon fiber composite specimens were burned in 24 of the fire tests. The composite material was T-300 carbon fiber with 5208 epoxy matrix taken from structural test panels supplied by NASA-LaRC. In determining the release of single fibers, this report considers, with one exception discussed later, only those fibers released with lengths greater than 1 mm. Fibers shorter than 1 mm were not considered significant in causing damage to electronic equipment (ref. 1).

Fiber Release and Mass Computations. - The number of single fibers released and passing through the test section was calculated by extrapolating the observed distribution of fibers on the samplers in the test section to the entire cross-sectional area of the test section. Similarly, the number deposited on the floor of the tube between the fire and the test section was calculated from the summation of the mean deposition on the sticky paper samplers at a station times the local projected horizontal area of the shock tube.

The mass of the single fibers released was obtained by dividing the total length of single fiber released by the length of virgin fiber equivalent to one gram (ref. 6). No allowance was made for reduction in fiber diameter due to oxidation. Thus:

$$\text{Mass} = \frac{(\text{Total number of fibers}) (\text{Average length})}{(15.2 \times 10^6 \text{ mm/g})}$$

The initial fiber mass was determined as the initial composite mass minus the initial epoxy matrix mass. The epoxy matrix mass was determined either experimentally by acid digestion of a composite coupon cut from the composite test specimen, or was assumed to be the design average value of 30 percent by mass.

Fiber Release Development Tests. - Six representative tests of the 24 carbon fiber burn tests have been selected for discussion. Significant data for these six tests are listed in Table I.

In test 29, a single heavy stiffened panel, representative of an aircraft wing surface, was suspended over the fire and burned. Fuel was pumped for 30 minutes, and the fire continued to burn for another six minutes. Only 0.01 percent of the initial carbon fiber mass was released as single fibers. Sixty-five percent of the initial mass of this panel was recovered.

In an attempt to enhance the single fiber release, test 30 was conducted with a thinner stiffened panel. The panel was cut into six pieces, all of which were suspended over the fire, and burned for 20 minutes. Single fiber release was increased to 0.22 percent of the initial carbon fiber mass. Only 43.5 percent of this specimen was recovered, indicating a larger amount consumed in the fire.

Examination of the residual material from both tests 29 and 30 indicated that most of the epoxy matrix had been consumed in the fire; however, TGA testing showed that approximately five percent of the epoxy had been converted to a carbonaceous char which continued to hold most of the carbon fibers together in the form of the original panel. Surface plies were observed to be delaminated and the panel edges were severely burned and frayed. Many fibers were apparently ready to be separated from the panel and carried off in the hot plume. Attempts to increase the single fiber release by mechanically shaking and by blowing nitrogen gas over the burning mass had no significant effect. Therefore, for the subsequent tests, the length of available edge material was increased by cutting the composite panel into a greater number of smaller pieces and mechanically delaminating these pieces into four to six ply thicknesses prior to burning.

One hundred of these thin strips of composite were stacked loosely in three piles in a flat, expanded-metal mesh holder in test 39. No change was observed in the number of fire-released fibers passing through the test section. However, after the jet fuel fire burned out, the residual composite material in the three piles was observed to continue to burn like charcoal, without flames, for more than an hour. This post-fire burning reduced the residual mass noticeably so that only 32.4 percent was recovered. The ability of an aviation jet fuel fire to create oxidizing conditions for composite materials exposed to the fire was clearly demonstrated in this test.



Finally, a significant increase in single-fiber release was obtained by tumbling the thin, delaminated strips in a rotating mesh basket, and by extending the burn time until the material in the basket was fully consumed or dispensed. Tumbling at speeds other than 5 rpm did not seem to enhance single fiber release.

In test 48, 100 strips of composite were tumbled at 5 rpm and burned for 84 minutes. Fifteen times more single fibers passed through the test section than in test 39. The 36.9 percent recovered residual material was primarily material that worked its way through the basket mesh and dropped on the floor of the tube just downwind from the fire.

Test 49 was a repeat of test 48 except the basket was nearly filled with 460 strips of composite material, and four hours of burning and tumbling were required to empty the basket. Thirty times more fibers were recorded passing the test section than in test 48, and only 9.5 percent of the material worked out of the basket. Even for these significant improvements in fire release of fibers, the total mass released was only 1.09 percent of the initial mass of carbon fiber. However, the fiber exposure at the test section was comparable to exposure levels which caused failures in chamber tests with virgin fibers.

Electronic Equipment Exposure Test. - After several aborted attempts, test 53 was conducted essentially as a replicate of test 49, but with six stereo power amplifiers installed and operating in the test section. The specimen basket was filled with 500 strips of composite, (10 kg of material). The material was consumed or dispensed in only 2 1/2 hours compared with 4 hours in test 49. Figure 26 is a photograph of the basket after about 2 hours of burning. The dark area in the bottom of the basket is the remaining material continuing to be tumbled and burned. The shorter burn time for test 53 (150 minutes to empty the basket) was believed to have been the result of rebuilding the rotating basket with a larger steel mesh (14 mm squares) than had been used for the basket in test 49 (6 mm squares). More of the composite material was thrown out of the basket before being burned as shown by the 33.6 percent residual compared with the 9.5 percent residual for test 49.

A larger number of fibers were released in test 53, but the released fiber mass was less than test 49 because the average fiber length was less. The cause of the difference in average length is unknown, but it may have been influenced by the difference in total burn time, or by a difference in average burn temperature.

The fire temperature history at the rotating basket to which the carbon fibers were exposed before their release is shown in figure 27. The fire temperature rose rapidly after ignition to the 900 to 1000°C range. A trend of a gradual decrease in fire temperature was observed with the long burn time, and short-term oscillations of plus or minus 75°C occurred throughout the fire. The average fire temperature for the 150 minutes of active burning was 750°C for test 53 which was significantly less than the average temperature of 880°C measured for test 49.

Failures occurred in each of the six stereo power amplifiers exposed to the fire-released carbon fiber environment during test 53. Times to failure are listed in Table II. Three other tests were conducted in which the stereo power amplifiers were operated in the shock tube. These other three tests, also listed in Table II, were intended to provide a basis for isolating the effects on the electronics of the fuel and composite resin products of combustion from the effects of the carbon fiber released in test 53. Only one of the 14 amplifier tests in the non-carbon fiber fire environment produced a failure, and it was diagnosed as probably resulting from a part or parts failure unrelated to the exposure in the shock tube environment. Amplifier performance during the tests is described in reference 3.

The carbon fiber exposure levels which had occurred at the times of failure in test 53 are listed in Table II. These exposure values were obtained from averages of exposures determined from various types of instrumentation as discussed in the following section. Mean exposure to failure for the six amplifiers was  $2.0 \times 10^6$  fiber seconds/meter<sup>3</sup> for test 53. The probability of failure for these six amplifiers as a function of fiber exposure is shown in figure 28. They are compared with a predicted exponential probability of failure based on the mean exposure to failure ( $2.5 \times 10^6$  fiber seconds/meter<sup>3</sup>) of similar amplifiers tested in a closed chamber with 3 to 4 mm chopped, virgin T-300 carbon fibers (ref. 7). The vulnerability predicted from the chamber tests was almost exactly reproduced by the amplifiers in the fire-released fiber test 53. A similar correlation is shown in reference 8 based on an analytical treatment of vulnerability to mixed-length carbon fibers.

The air temperatures at two locations in the test section during the amplifier testing are shown in figure 27. The peak air temperature history was recorded from a thermocouple located 0.3 m below the ceiling. It averaged 50°C throughout the 150 minutes of test. Air temperature at the elevation of the stereo power amplifiers (2.44 m above the floor in the test section) rose from an initial ambient air temperature of 26°C to a maximum value of 33°C at the end of the burn. This thermal environment was well within the operational capability of the amplifiers.

Fire-Released Fiber Dissemination. - Fibers released from the fire tests were carried downwind in the hot plume inside the shock tube past the test section to the water scrubber. Turbulent mixing between hot and cold portions of the air stream as well as natural diffusion distributed the released fibers throughout the air flowing down the tube.

The deposition of fibers falling out of the airstream onto the floor of the shock tube at various locations in test 53 is shown in figure 29. Each point shown represents the average of the deposition on the three sticky paper deposition samplers at that cross section (fig. 12). A study of the deposition across the width of the tube indicated no particular pattern, but rather a random variation associated with the scatter in data from sampler to sampler. The trend of the deposition along the length of the tube showed essentially a doubling of the unit deposition near the test section compared to that which occurred close to the fire.

Theoretical calculations based on fiber fall velocity of 0.02 m/s showed that a horizontal air velocity ranging from 1.45 m/s at the fire region to 0.67 m/s at the test section would carry a fiber farther downwind than the scrubber before it would reach the floor of the tube, assuming the fiber was initially lofted to the ceiling by the fire and neglecting turbulent mixing. The low deposition shown at 202 m downwind from the fire (fig. 29) was probably caused by the presence of a plume deflector fence built into the ceiling of the tube near that location which disturbed the air flow locally, but had no apparent long-range effects.

The average length of the fibers deposited on the floor of the tube in test 53 is shown in figure 30 as a function of downwind location. No trend for preferential length is evident. Overall average length is 2.66 mm and individual location values range from 2.36 to 2.96 mm. These average fiber lengths from deposition on the floor are greater than the 2.14 mm value listed in table I for test 53. The 2.14 mm length was determined from fibers sampled near the center of the tube cross section by canister collectors at the test section and was considered to be more representative of the fibers to which the amplifiers were exposed.

The variation in fiber exposure in a vertical profile from the test section floor to the shock tube ceiling for test 53 is shown in figure 31. These fiber exposures are based on sticky cylinder samplers on four trees at various locations in the test section (fig. 18). A two-to-one variation in fiber exposure was measured with the sticky cylinders. The center one-third of the shock tube cross section had the highest exposure, averaging about  $1.4 \times 10^5$  fiber seconds/meter<sup>3</sup>. This can be compared with

the calculated equivalent exposure from the deposition sticky samplers on the floor of the test section. They had an average deposition of  $7.9 \times 10^4$  fibers/meter<sup>2</sup> (fig. 29). This deposition can be converted to exposure by dividing by the fiber settling velocity 0.02 m/s, resulting in fiber exposure of  $4.0 \times 10^6$  fiber seconds/meter<sup>3</sup>.

The fiber exposure determined from the deposition sticky samplers on the floor was an order of magnitude greater than that determined from the sticky cylinder samplers. This difference had been observed in earlier tests and had raised a concern that the sticky cylinders might have become saturated with soot, moisture, and/or fibers from the long burn times. Therefore, a system was devised for incrementally sampling through the top of the test section (fig. 18) with interchangeable sticky cylinders.

Fiber exposure in test 53, determined by the sticky cylinders which were interchanged every 15 minutes throughout the test time, is shown in figure 32. The exposures determined for the individual sets of three cylinders were summed cumulatively and indicate an essentially constant rate of fiber passage through the test section. The total fiber exposure of  $0.9 \times 10^6$  fiber seconds/meter<sup>3</sup> is six times greater than the exposure determined by the continuously-exposed sticky cylinders mounted on the trees, but is still significantly less than the exposure determined from the deposition sticky samplers. Thus it would appear that in addition to, or in lieu of, a saturation of the sticky cylinder sampler, the sampler collection efficiency or calibration may have been reduced by exposure in the shock tube to an environment containing products of combustion including high humidity. Other types of instrumentation that were being developed for sampling fibers in the large-scale outdoor fire tests (refs. 3, 4, and 5) were also installed in the shock tube to sample the fibers passing through the test section. A discussion of these follows.

The number of fibers collected by five cardboard canisters and one metal canister located in the test section as shown in figure 18 are listed in Table III. The metal canister had a larger inlet opening which allowed more fibers to pass inside; so the total fiber count for the metal canister had to be reduced in order to compare directly with the cardboard canister fiber counts. The reduction was based on the ratio of the inlet cross-sectional areas of the metal and cardboard canisters.

A representative sample of fibers from each canister was sized for fiber lengths and diameters. Corrections were applied to the apparent length spectrum to increase the number of fibers in the 1 to 2 mm length interval by 18 percent and in the 2-3 mm length interval by 9 percent to allow for the slippage of short fibers through the collector mesh. These were the same slippage

factors that had been established at the U.S. Army Dugway Proving Ground (ref. 9) for samplers with similar size mesh. Another correction was applied to the number of fibers collected to adjust for the canister collection efficiency based on the airflow calibration (fig. 20).

Total fiber exposure for test 53 was determined by the canister collector data to be  $11.85 \times 10^6$  fiber seconds/meter<sup>3</sup>. This value was obtained by dividing the average adjusted total number of fibers collected, 5064 fibers, by the canister inlet area,  $6.38 \times 10^{-4}$  m<sup>2</sup>, and by the air stream velocity at the test section, 0.67 m/s.

The concern expressed earlier that the sticky cylinders may have been ineffective in sampling led to the installation of the prototype model of the charged grid detector. The prototype model was first used in test 49 to determine the rate of fiber release and subsequent passage through the test section. Figure 33 shows a linear increase in fiber exposure with burn time for test 49, which corresponds to a constant rate of release of fibers. Both the prototype and a redesigned, model 1, charged grid detector were operated in test 53. The prototype model malfunctioned and did not return useful data. The model 1 charged grid detector counted fibers throughout the test. Because of operational problems associated with grid saturation, valid single fiber resistance data was not obtained.

Fiber count data from the model 1 charged grid detector are shown in figure 34 by a plot of the fiber exposure as a function of test time for test 53. It shows a linear increase in exposure, very similar to the output from the prototype model in test 49. The fiber exposure shown in figure 34 has been adjusted to provide for the increased number of fibers actually passing the grid. Based on the length spectrum measured in the canister collector samples, 57 percent of all fibers with lengths greater than 1 mm had lengths less than 2 mm, and therefore, would be expected to slip through the charged grid without being counted. The maximum value of this adjusted fiber exposure was  $14.54 \times 10^6$  fiber seconds/meter<sup>3</sup>.

Fiber exposure histories measured by two light-emitting diode (LED) detectors are shown in figure 35. Although the absolute values of fiber exposure differ by a factor of three for the two units, the shapes of their outputs are quite similar, and both indicate an essentially linear increase in fiber exposure with time. Unit G-10 counted only fibers longer than 2 mm, while unit A-2 counted only fibers longer than 4 mm. Exposure corrections to account for fibers shorter than those detected by the LED units were based on the length spectrum from the canister collector samplers.

An additional correction was made to the output from unit G-10 because its beam was oriented horizontally in the shock tube. Fibers tend to float in the airstream with long axis horizontal. The obscuration of the LED light beam by a fiber is a function of the projected length of the fiber perpendicular to the axis of the beam. For the length spectrum used, only 54 percent of the available fibers would be counted by the horizontal beam LED, due to the random orientation of the fibers in the horizontal plane.

A comparison of fiber exposures in test 53 as measured by all of the preceding instrumentation is shown in figure 36. The sticky samplers, both deposition sticky papers and sticky cylinders demonstrated a strong indication of reduced collection efficiency, probably due to an effective loss of adhesion in the presence of high humidity and extensive soot. Their exposure values are not included in the overall average shown. The overall average maximum fiber exposure  $15.33 \times 10^6$  fiber seconds/meter<sup>3</sup>, was obtained by averaging the maximum exposures of the two LEDs, the charged grid detector and the canister collectors. The overall average exposure history shown by the dashed curve in figure 36 was obtained by taking ratios of the charged grid detector exposures at various times, based on the ratio of exposures at the maximum exposure,  $15.33/14.54$ . This overall average fiber exposure curve was used to determine the fiber exposure values at the times observed for failure of each of the six amplifiers (Table II). These fiber exposures at the times of amplifier failure were also used in plotting the exposure versus amplifier probabilities of failure in test 53 shown in figure 28.

Fire-released fiber size spectra. - The spectra of lengths of fibers from samples collected in the canisters and from the sticky cylinders that were interchanged at 15-minute time increments in test 53 were quite similar (fig. 37). The overall average length of 2.12 mm for fibers greater than 1 mm in length was significantly less than the 2.66 mm average length for fibers deposited on the floor of the shock tube (fig. 30). This indicates that a smaller proportion of the short fibers settled out of the air than were actually present. The average lengths and spectra of lengths of the airborne fiber samples and the floor deposition fiber samples longer than 1 mm were within the range

of length spectra previously reported from a variety of chamber burn tests with propane and natural gas (ref. 1).

The spectrum of diameters (fig. 38) of fibers from the canister samplers indicated that many of the fibers had been reduced in size. The smooth, uniform appearance of most of these reduced diameter fibers suggested that oxidation in the high temperature portion of the fire was the probable cause of the reduction. The sooty nature of the aviation jet fuel fire was indicative of inefficient and incomplete combustion, but apparently did not represent a total lack of oxygen.

The fiber length and diameter spectra shown in figures 30, 37, and 38 did not include fibers shorter than 1 mm. Although the electrical effects of fibers shorter than 1 mm were not considered significant (ref. 1), carbon fiber samples from several tests were analyzed for the presence of fibers shorter than 1 mm. Table IV and figure 39 show the distribution of diameters and lengths of fibers from a sample collected in test 44. The sample was taken from the screen of a canister type collector located in the smoke plume approximately 5 m downwind from the fire. Figure 40 is a photograph of a portion of the .6 mm mesh collector screen from which the sample was taken. The soot and fiber buildup on the screen was typical of that observed at a similar location in subsequent tests. The screen would normally only collect fibers longer than the mesh opening, however because of the heavy soot deposit, shorter fibers were also collected.

The fibers and soot were separated from the mesh by washing in a detergent and water solution. The fibers were then separated from the soot using a differential sedimentation technique. The sides of the beaker containing the detergent solution and residue were insulated and the bottom was cooled. This reduced convective currents and allowed differential sedimentation. In intervals of two hours, the top 3/4 of detergent containing only soot was drawn off and replaced by fresh detergent. After five cycles of remixing the remaining 1/4 of the solution with fresh detergent, the mixture was deposited on a fine filter.

The filter surfaces were then prepared for scanning electron microscope observation. Long fibers (1-10 mm) were counted from photographs taken at magnifications of between X10 and X30. The field of view was made large enough until at least 100 fibers could be counted. This required the assembly of montages of up to 50 individual pictures. The smaller fibers were counted on reproductions at magnifications of X300, similar to figure 41. To obtain the distribution of lengths and diameters of all fibers, the count densities were calculated as counts per unit area for the long fibers (> 1 mm) on the X30 reproduction and for the short fibers (< 1 mm) on the X300 reproduction.

The peak of the length distribution was found to be between 178 and 316  $\mu\text{m}$ , and the peak of the diameter distribution was found to be between 3 and 4  $\mu\text{m}$ . The length distribution decreases steeply for lengths smaller than 50  $\mu\text{m}$ . The fibers in that range were still large enough to be easily observed on the photomicrographs and were much too large to be passed by the filter. Hence, the falling off of the distribution was considered related to the source of the fibers rather than the method of observation. Approximately 95% of the fibers were found to be shorter than 1 mm. It should be noted that the sample may not have been representative of the airborne fiber distribution due to passage of shorter fibers through the screen mesh. Also, some of the longer fibers may have broken during the washing and sedimentation operations. However, it is concluded that numerous reduced diameter fibers shorter than 1 mm are released from burning carbon fiber composites.

In addition to the above investigation of the presence of short, reduced diameter fibers, several unsuccessful attempts were made to collect fibers in the respirable size range (diameter less than 3  $\mu\text{m}$  and lengths less than 80  $\mu\text{m}$ ) using the NIOSH millipore samplers shown in figure 24. The samplers were used in test 51 to sample the exhaust from the shock tube; however, no fibers were detected. Soot saturation of the millipore filters may have obscured any fibers collected. Several samplers were also exposed for approximately five minute periods each in the test section during test 53. No fibers were found in the areas searched on those samplers.

Composite mass balance. - Carbon fiber oxidation was further indicated by a mass balance of the composite material recovered after each fire test. The percent of the mass of the initial composite material that was recovered in 13 of the 24 fire tests in which composite material was burned is shown in figure 42. The major portion of the recovered material was in strip form that was picked up from the region of the specimen holding basket and downwind from the fire. The comparatively small proportion of the initial mass that was estimated to be released as single fibers is shown for tests 48, 49, and 53. (The estimates were based on single fiber count data from the test section instrumentation.) The combined mass of the recovered composite and the released single fibers ranged from 10 to 68 percent of the initial mass. If the epoxy matrix had been the only part of the composite consumed in the fire, 70 to 75 percent of the initial mass should have been accounted for. Therefore, a considerable amount of the carbon fiber must have been consumed or oxidized in the fire.

Electrical characteristics of fire-released fibers. - Several samples of carbon fibers from the shock tube were analyzed to establish the electrical resistance of these fire-released single fibers. The fibers were collected on an additional set of sticky cylinders on one of the trees in the test section during test 53.



These additional sticky cylinders were not mounted on aperture cards, but were retrieved in cylinder form. For the resistance measurements, 5 mm wide strips were cut from the sticky cylinders and bonded, adhesive and fiber side down, on the surface of a copper-plated circuit board with a 2.3 mm gap between two conductive areas. The fibers crossing the gap were observed under a microscope and all but one were eliminated by cutting with a razor blade. The diameter of the one fiber remaining was measured optically under the microscope.

Five discrete voltages up to a maximum of 12.5 volts were applied incrementally to the circuit board, and the resulting current flow through the single fiber was measured. The gross electrical resistance for the fiber was taken as the slope of the straight line fitted to these five voltage-current data points (fig. 43). A correction for single fiber contact resistance was established based on the difference in average resistance for the three 7  $\mu\text{m}$ -diameter fire-released fibers and the calculated resistance for virgin 7  $\mu\text{m}$ -diameter fibers obtained from the published electrical resistivity of 18  $\mu\text{ohm}\cdot\text{m}$  (ref. 6). A second effect observed (fig. 43) which was not included in the correction to fiber resistance was the approximate one volt which had to be applied before any current was observed to flow. The fiber contact resistance would appear to be extremely high for applied voltages up to one volt, at which point the contact resistance would appear to break down to a second, constant value of about 340 ohms for both ends of a single fiber lying across flat copper conductors.

A total of seven single fire-released fibers of sufficient length to bridge the 2.3 mm gap were isolated and measured. Four of these had diameters which had been reduced by oxidation. The increase in electrical resistance for the reduced-diameter fibers is shown in figure 44. Three fibers with diameters of about 5  $\mu\text{m}$  showed an average resistance of 1.8 times the virgin fiber resistance and one fiber with a reduced diameter judged to be approximately 2.5  $\mu\text{m}$  had a resistance 11.4 times the virgin fiber resistance. The predicted change in resistance based solely on change in fiber cross-sectional area is shown by the curve in figure 44 and appears to be in reasonable agreement with the measured resistances considering the possible errors in determining fiber diameter for fibers embedded in the under surface of the adhesive-coated transparent film.

#### CONCLUDING REMARKS

Six stereo power amplifiers were shown to be vulnerable to damage by airborne carbon fibers released from the burning of T300-5208 carbon-fiber epoxy composite material in aviation jet fuel fire tests. The mean exposure to failure of  $2.0 \times 10^6$  fiber seconds/meter<sup>3</sup> for fire-released fibers was a close match to the

vulnerability predicted from laboratory tests with virgin fiber.

However, the stereo power amplifiers had a low-to-negligible vulnerability to damage by soot, composite matrix epoxy resin residue, and other products of combustion from the aviation jet fuel burned in several additional tests.

For the amplifier vulnerability test, the total mass of single fibers longer than 1 mm released from the two and one-half hour burning of composite material was 0.75 percent of the initial carbon fiber mass, and the mean fiber length was 2.12 mm. Both of these values are within the range of values reported from laboratory burning tests of composite material.

A considerable amount of carbon fiber oxidation was postulated from the observed reduction in released fiber diameter and from the post-test mass balance measurements. Electrical resistance measured for fire-released single fibers was 2 to 11 times greater than virgin fiber resistance which is in reasonable agreement with predicted increases based on changes in fiber cross-sectional area.

## REFERENCES

1. Assessment of Carbon Fiber Electrical Effects. NASA CP-2119, 1979.
2. Pride, R. A.: Carbon Fiber Counting. NASA TM-80117, 1980.
3. Experimental and Analytical Studies for the NASA Carbon Fiber Risk Assessment. (The Bionetics Corporation, NASA Contract NAS1-15238). NASA CR-159214, 1980.
4. Peterson, William A.; Carter, F. L.; and Whiting, John H.: Methodology Study for the Development of a Passive Sampler for Fire-Released Carbon Fibers. U. S. Army Dugway Proving Ground, DPG-TR-78-314, 1980. (Available as NASA CR-159351 )
5. Chovit, A. R.; Lieberman, P.; Freeman, D. E.; Beggs, W. C; and Millavec, W. A.: Carbon Fiber Plume Sampling for Large-Scale Fire Tests at Dugway Proving Ground. (TRW Defense and Space Systems Group, NASA Contract NAS1-15465). NASA CR-159215, 1980.
6. "Thornel" 300 Carbon Fiber Grade WYP 15 l/0. Union Carbide Corporation Carbon Products Division. Technical Information Bulletin No. 465-227, May 1980.
7. Stumpfel, Charles R.; and Weaver, Calvin E.: Measured Carbon Fiber Exposures to Malfunction for Civilian Electronic Items. ARBRL-MR-02943, U. S. Army Ballistics Research Laboratory, 1980. (Available as NASA CR-159347)
8. Elber, Wolf: The Vulnerability of Electric Equipment to Carbon Fibers of Mixed Lengths - An Analysis. NASA TM-80215, 1980.
9. Salomon, Lothar L.; Trethewey, John D.; and Bushnell, Melvin J.: Evaluation of Clouds of Airborne Fibers. The Army Science Conference Proceedings, 18-21 June 1974, Vol. III Principal Authors S-Z, United States Military Academy, West Point, NY. AD 785675.

TABLE I.- FIRE-RELEASED CARBON FIBER DATA FROM REPRESENTATIVE TESTS SELECTED FROM THE 24 IN WHICH CARBON-FIBER-EPOXY COMPOSITES WERE BURNED IN AVIATION JET FUEL FIRES IN THE SHOCK TUBE

Test no.	Burn time, min.	Agitation accompanying fire	Initial composite to be burned			Residual material recovered		Single carbon fibers, fire released					
			Configuration	Approx. part size, cm	Mass, g	Mass, g	Percent of initial mass	Number of fibers			Average length, mm	Mass, g	Mass, percent of initial fiber mass
								Airborne through test section	Deposited on floor	Total			
29	36	None	Stiffened panel, thick	30x50	3215	2115	65.8	$0.2 \times 10^6$ (b)	$1.7 \times 10^6$	$1.9 \times 10^6$ (f)	0.3	0.01	
30	20	None	Thin panel, cut into 6 pieces	15x20	724	315	43.5	0.4 (b)	5.5	2.40	0.9	0.22	
39	27	None	100 thin strips, in 3 piles	1x15	2000	648	32.4	0.2 (b)	(e)	1.90			
48	84	Tumbled in basket, 5 rpm	100 thin strips	1x15	2053	757	36.9	3.1 (b)	58.1	2.83	11.4	0.79	
49	240	Tumbled in basket, 5 rpm	460 thin strips	1x15	9279	877	9.5	4.1 (b)	206.7	3.50	71.0	1.09	
53	150(a)	Tumbled in basket, 5 rpm	500 thin strips, full basket	1x15	10000	3361	33.6	101.8 (c)	3.2 (b)	2.14	52.2	0.75	
						280.0 (d)	90.9						

(a) Basket was observed to be empty at 150 minutes; fire continued to burn to total time of 206 minutes.  
 (b) Sampled by sticky cylinders  
 (c) Sampled by charged grid detector  
 (d) Sampled by canister collectors  
 (e) Floor deposit not evaluated  
 (f) Average length of 2.50 mm was assumed for fiber mass calculation, Test 29 only.

TABLE II. - FAILURES OF STEREO POWER AMPLIFIERS  
 FROM EXPOSURES TO SOOT OR SOOT AND  
 FIRE-RELEASED CARBON FIBERS IN THE SHOCK TUBE

Test no.	Test environment	Amplifier number (a)	Time to failure, min.	Carbon fiber exposure at failure time, $f \cdot s/m^3$
1	Soot, 90 min	1	no failure	--
		2	no failure	--
38	Soot, 20 min.	1	no failure	--
		2	no failure	--
		3	no failure	--
		4	150	--
		5	no failure	--
		6	no failure	--
53	Soot, 206 min. and carbon fibers, 150 min.	1	40	$5.30 (10)^6$
		2	30	3.81
		3	10	0.78
		4	10	0.78
		5	10	0.78
		6	10	0.78
54	Soot, 143 min. and glass fibers, 105 min.	1	no failure	--
		2	no failure	--
		3	no failure	--
		4	no failure	--
		5	no failure	--
		6	no failure	--

(a) Amplifier numbers were arbitrarily assigned for each test and do not imply the same amplifier was in the same position on subsequent tests.

TABLE III.- CARBON FIBERS COLLECTED BY CANISTERS IN THE TEST SECTION  
DURING TEST 53

Canister number	Location (a)	Fibers collected, length > 1 mm	Adjusted total fibers, length > 1 mm (d)
Cardboard, 1	Top	3015	4039
2	Right	(b)	--
3	Bottom	2560	3430
4	Left	3141	4208
5	Center	4946	6625
Metal, 6	Left	7024 (c 5239)	7019
Average		3780	5064

(a) Five cardboard canister collectors were mounted on a stand as shown in figure 18 (c); a metal canister was mounted further to the left and further downwind as shown in figure 18 (d).

(b) Cardboard collector number 2 was not counted; held as a backup.

(c) Metal canister count reduced to equivalent of cardboard canisters on basis of inlet area ratios.

(d) Adjusted for fiber slippage through the 1 mm mesh based on apparent length spectrum, + 11.2%; and for collection efficiency based on airflow calibration, + 20.5%.

TABLE IV. - DIAMETERS AND LENGTHS OF SHORT SINGLE CARBON FIBERS MEASURED FROM SAMPLE COLLECTED IN THE SHOCK TUBE DURING AN AVIATION JET FUEL FIRE TEST.

Diameter, $\mu\text{m}$	Number of fibers in indicated $\mu\text{m}$ length interval													Total fibers
	<10 to 18	18 to 32	32 to 56	56 to 100	100 to 178	178 to 316	316 to 562	562 to 1000	1000 to 1780	1780 to 3160	3160 to 5620	>5620		
8			0	0	1	2	0	1						4
7-8		1	2	3	0	8	1	4	1					20
6-7			0	11	11	21	6	2	0					51
5-6			11	9	17	11	3	12	2	1				67
4-5		8	22	19	29	39	21	7	5	3	2	1		156
3-4		1	8	22	41	38	36	9	8	3	1			167
2-3	3		14	8	12	28	8	2	3					78
1-2		2	8	13	2	6	1	2						34
0-1			1	2	4	1	4	0						12
Total fibers	3	12	66	87	117	154	80	39	19	7	4	1		589

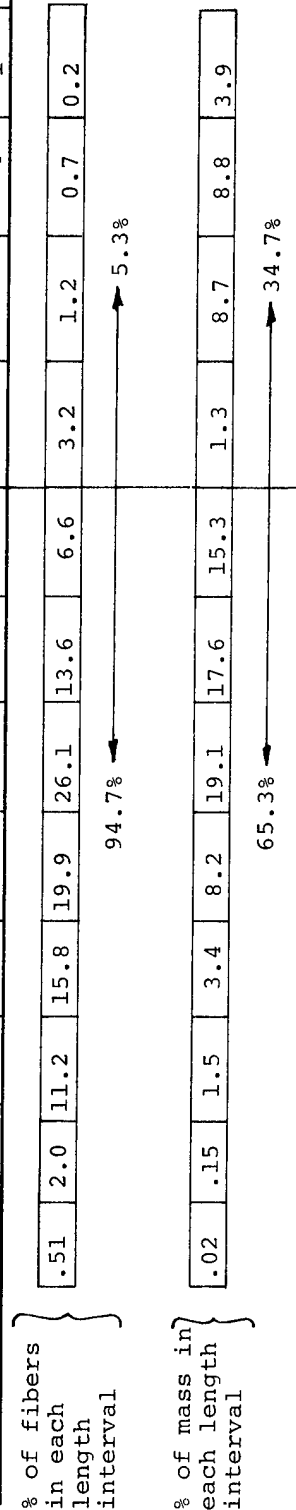

NASA  
L-78-8572

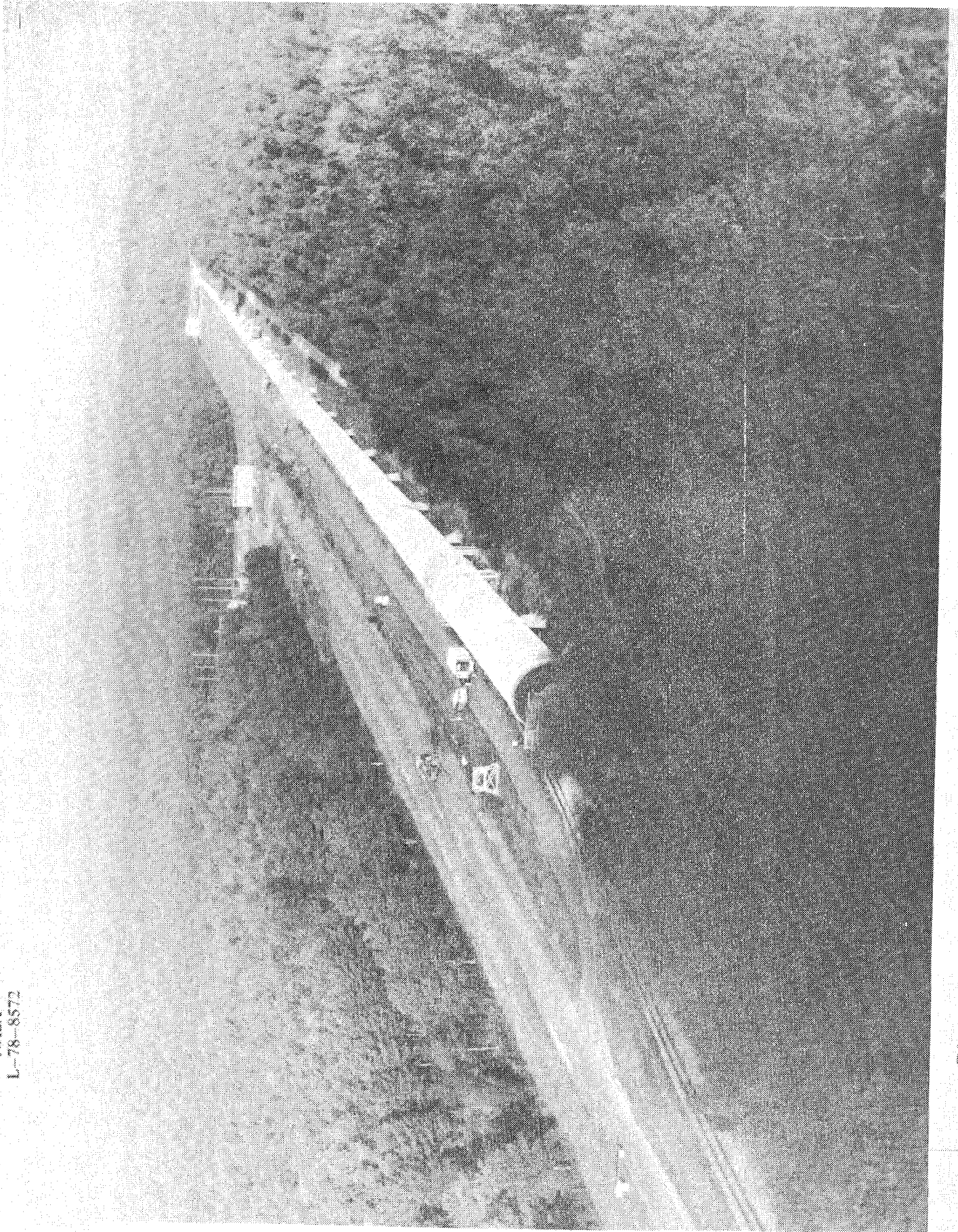

Figure 1. - Aerial view of shock tube during aviation jet fuel burn test.



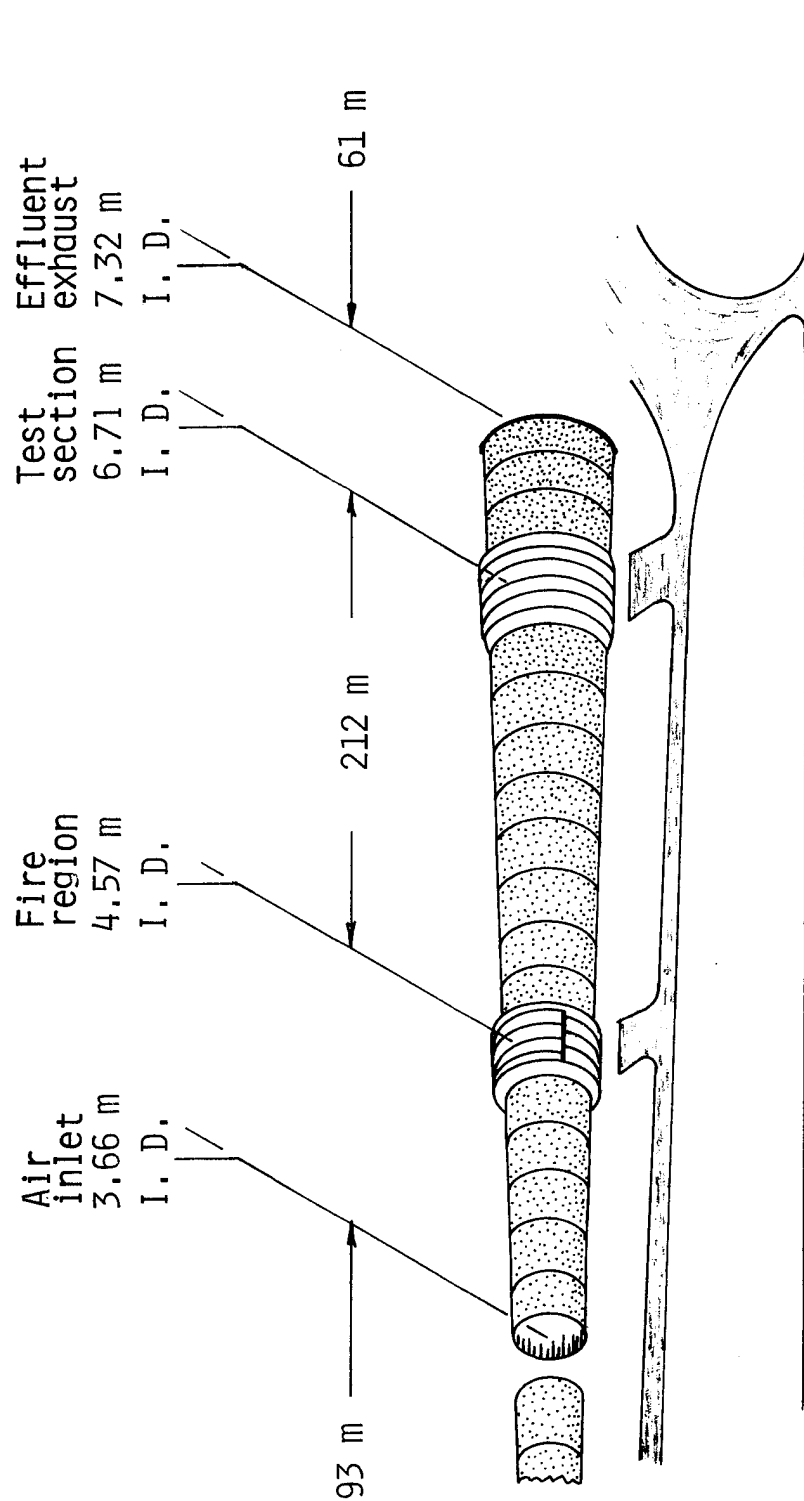

Figure 2. - Schematic view of the portion of the shock tube used for aviation jet fuel burn tests of carbon fiber composite.

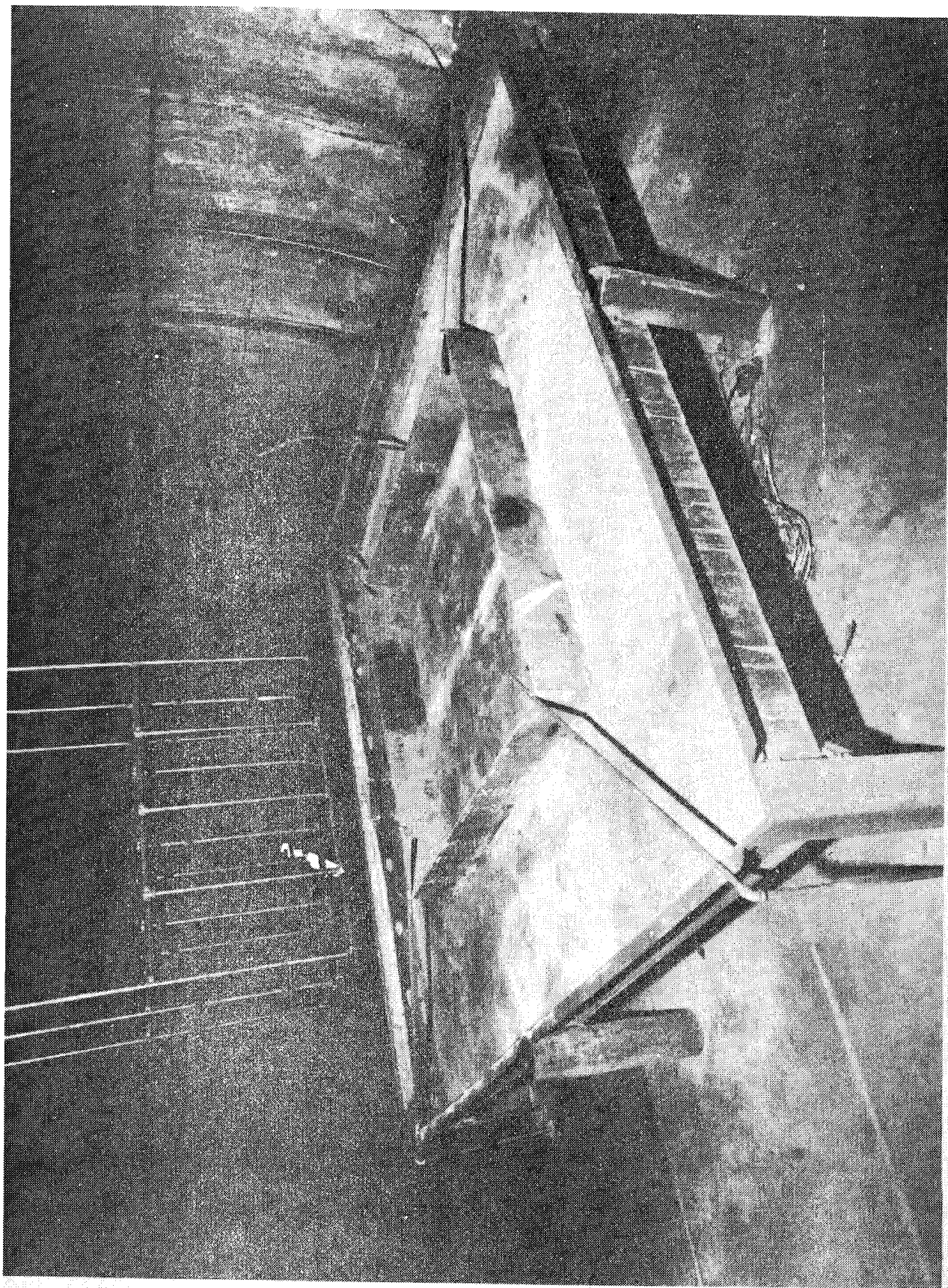

Figure 3. - Basic fire pan installation prior to addition of chimney and rotating specimen basket.

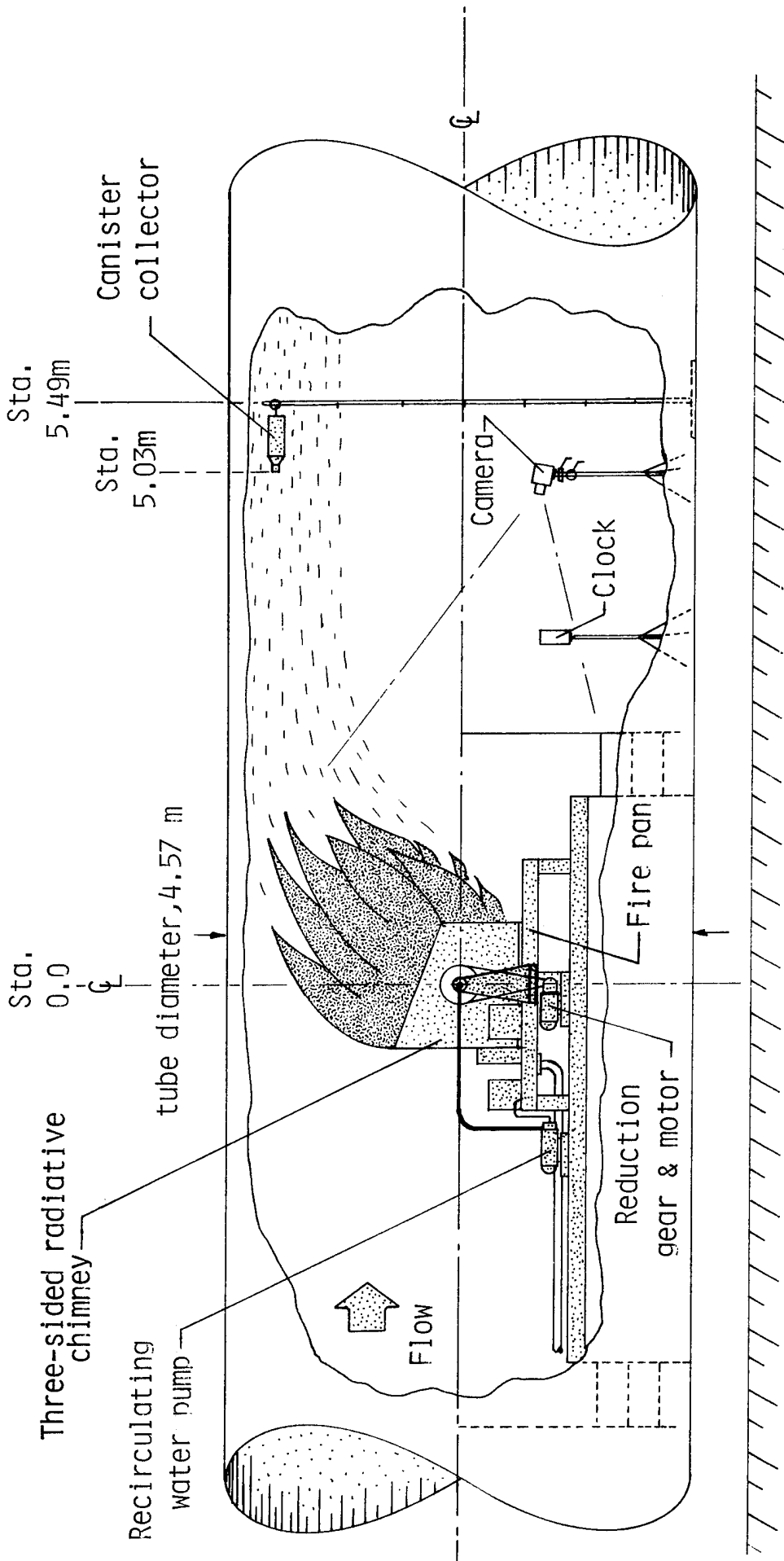
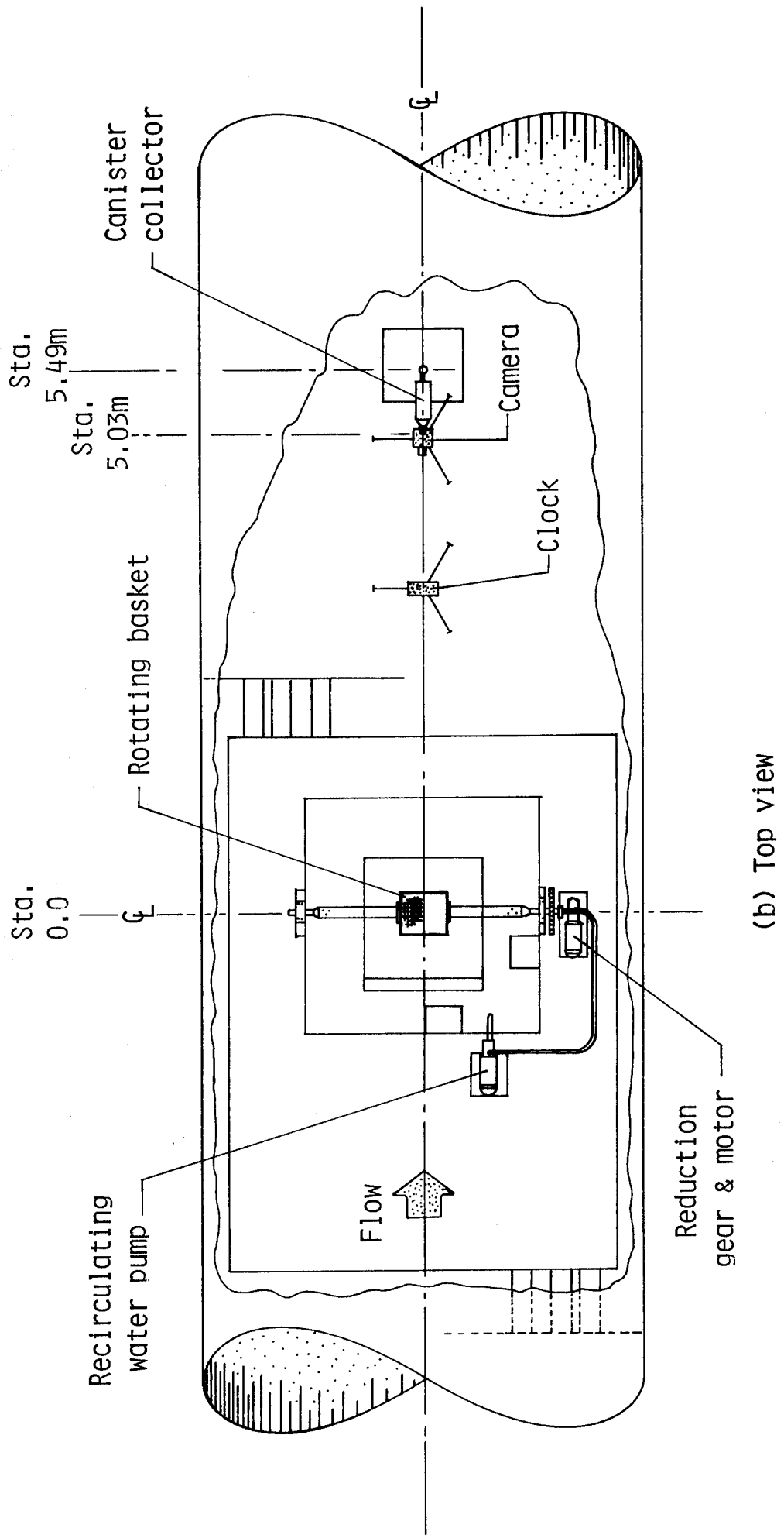
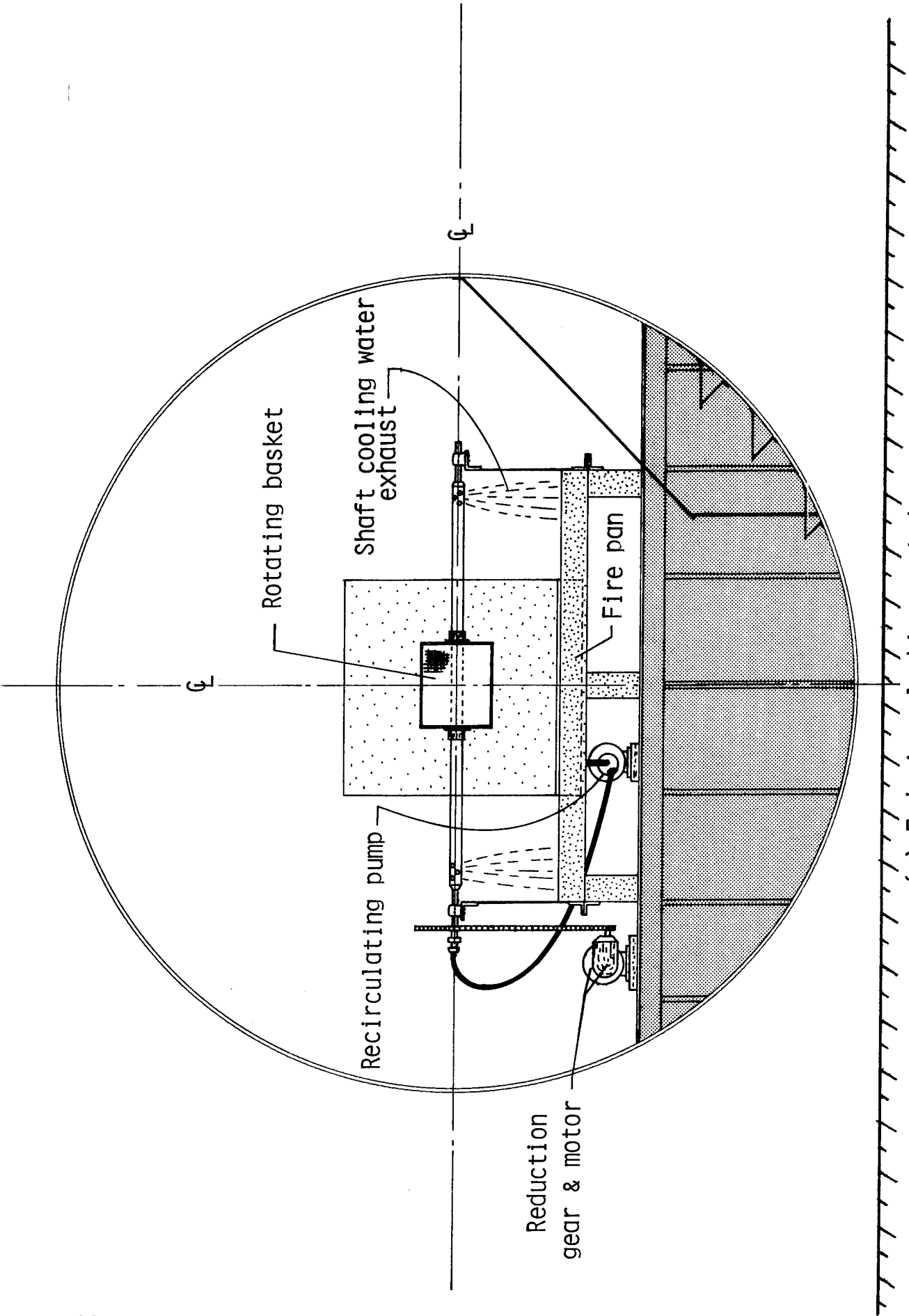

Figure 4. - Equipment installation in the shock tube at the fire region.



(b) Top view

Figure 4, - Continued



(c) End view, looking upwind

Figure 4, - Concluded



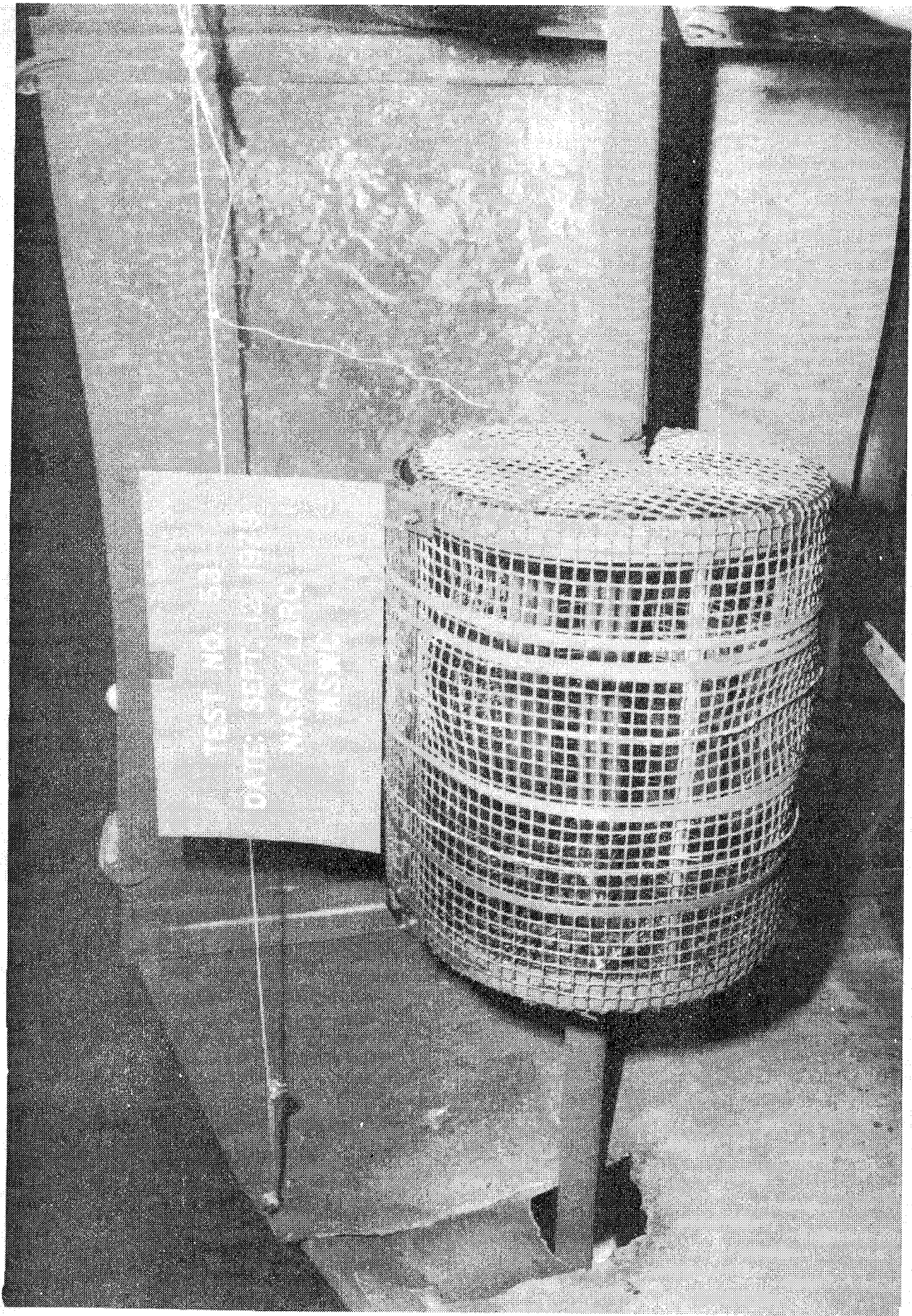

Figure 5. - Rotating specimen basket after aviation jet fuel fire test.

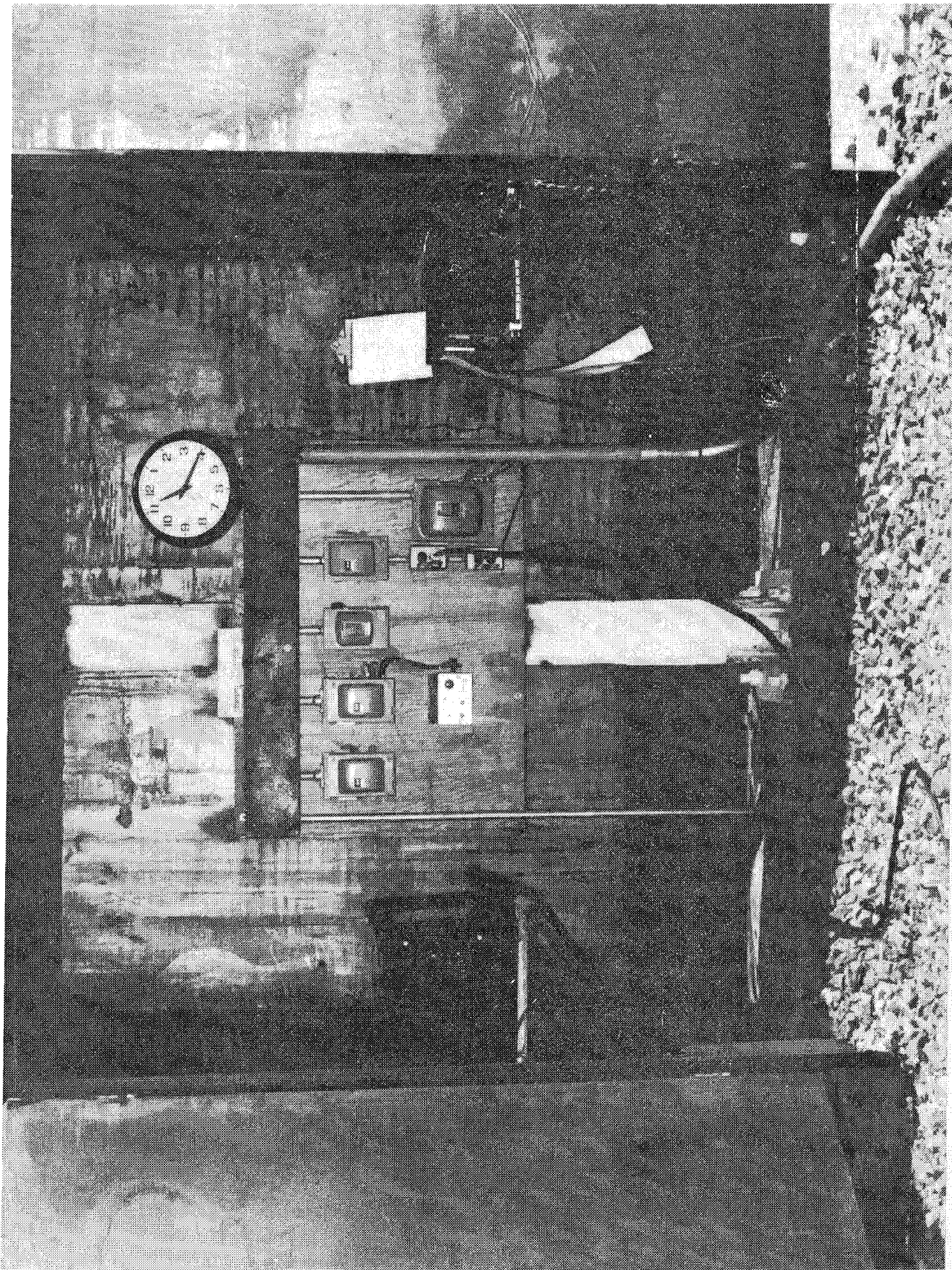

Figure 6, - Test control center outside shock tube near station 0 at the region of the fire pan.

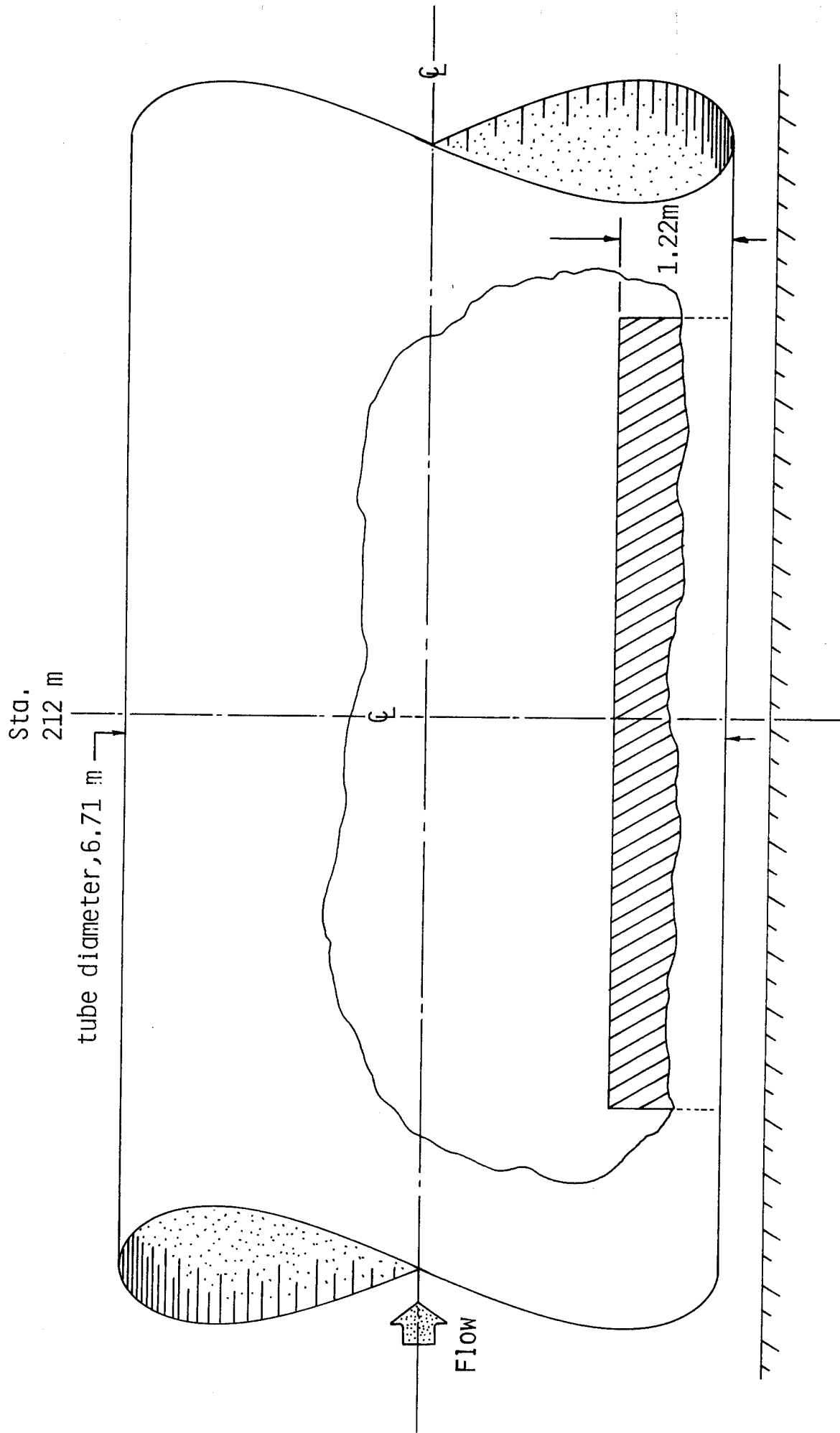

Figure 7. - Side view of test section in shock tube prior to instrumentation installation.



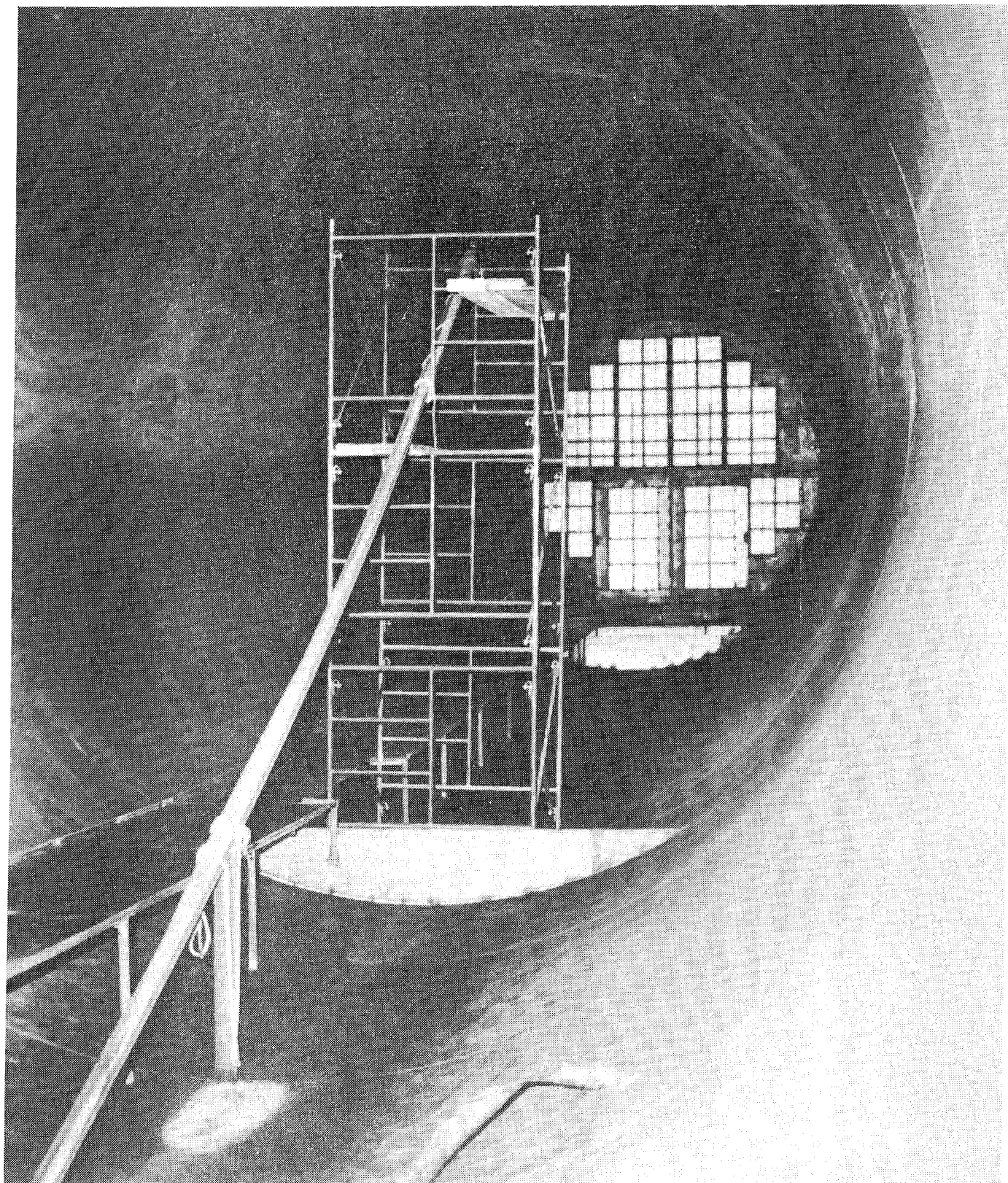

Figure 8. - Water scrubber looking downwind from test section.

Sta.  
234 m

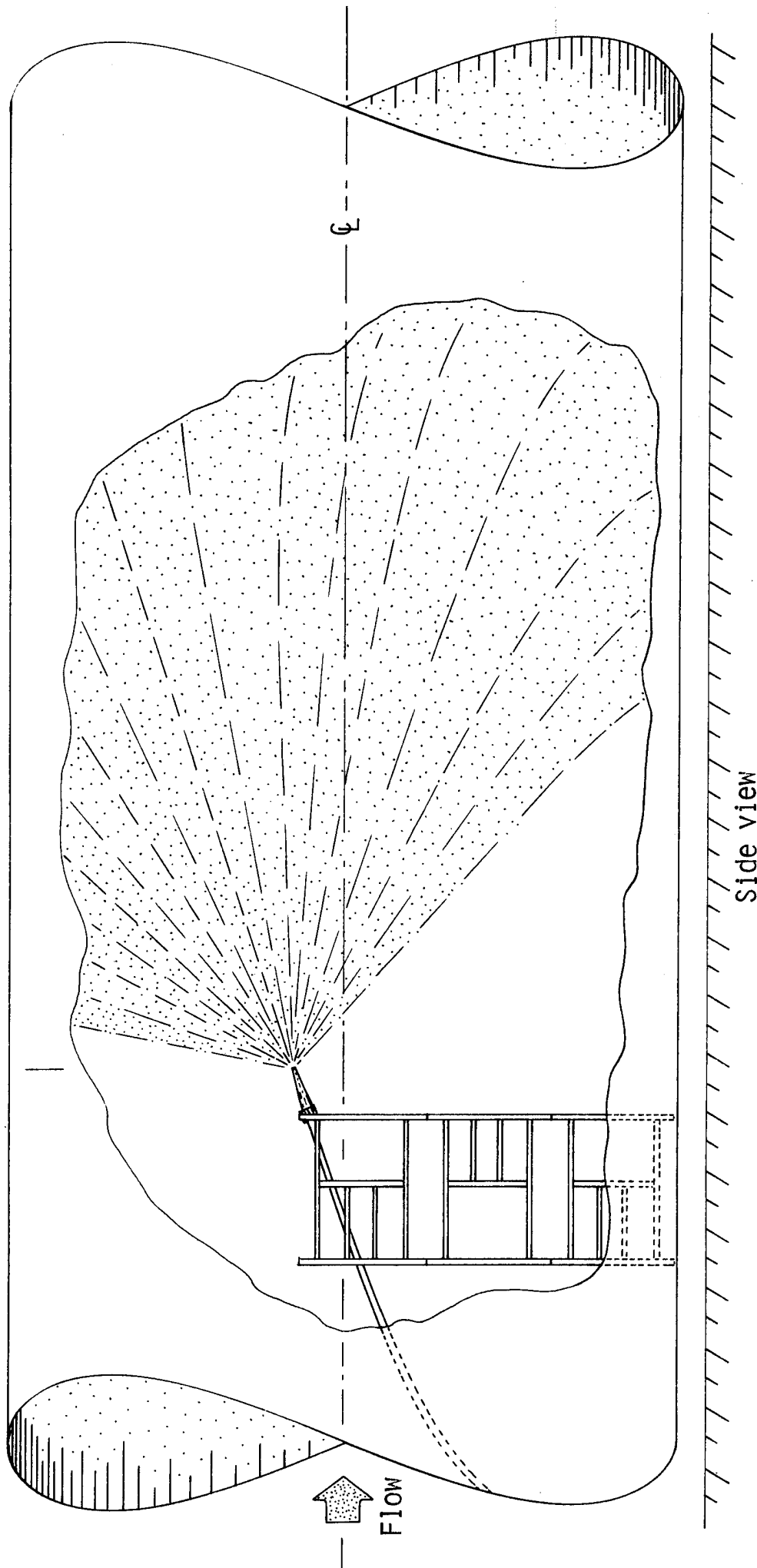

Figure 9. - Water scrubber schematic during operation.

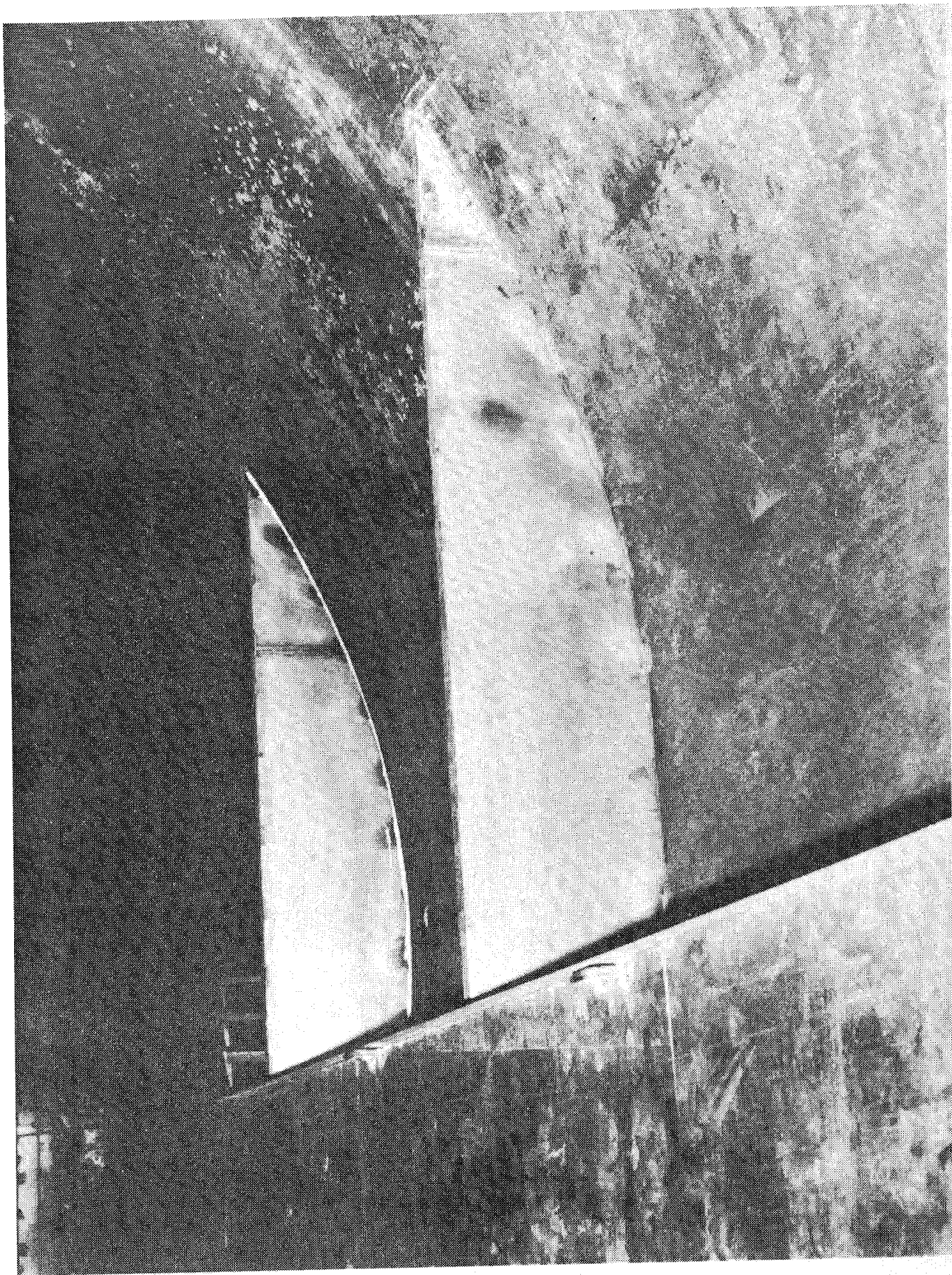

Figure 10. - Bulkheads to contain water from scrubber and to skim soot and fibers prior to draining.

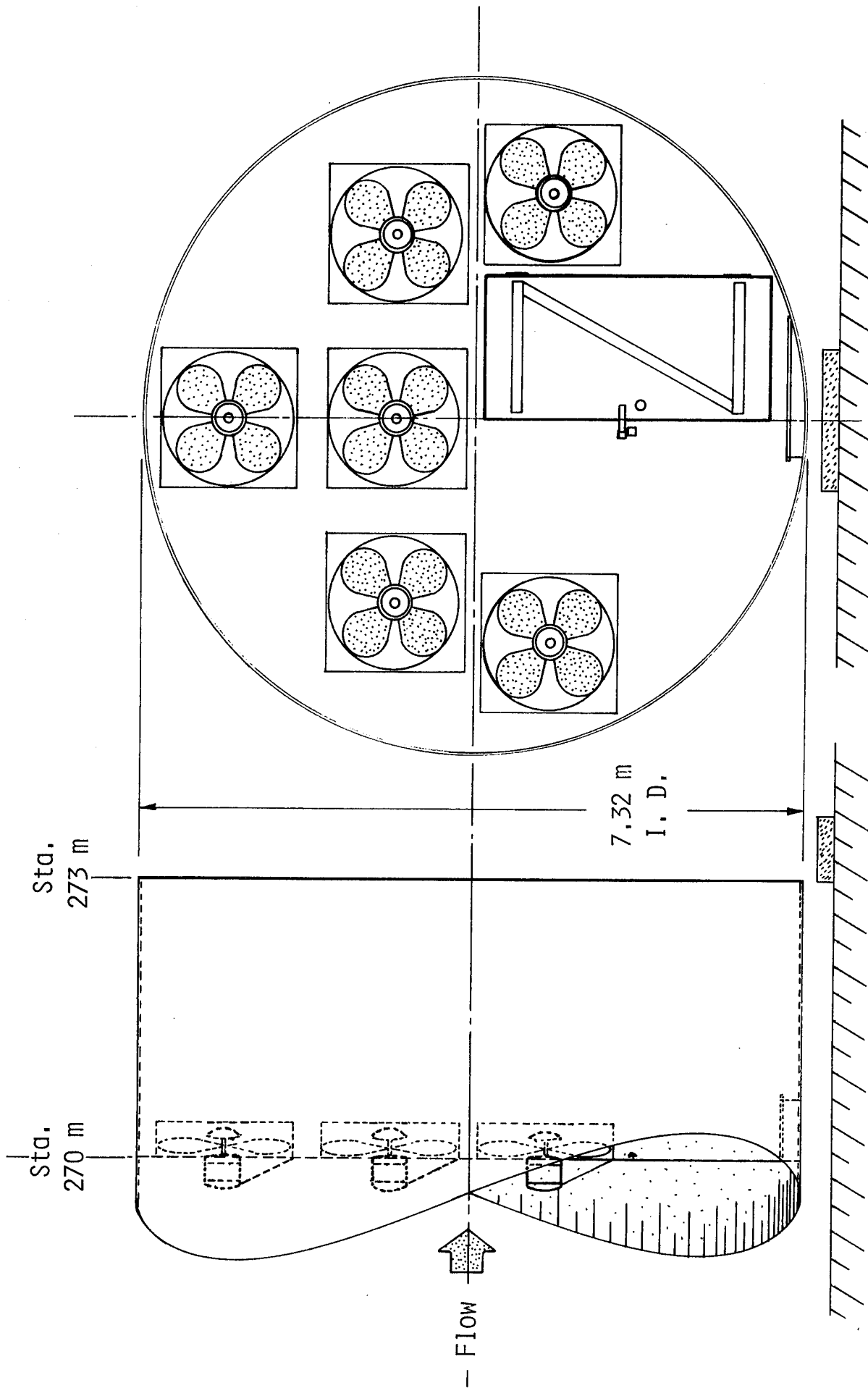

Figure 11. - Exhaust fan bulkhead at end of shock tube.



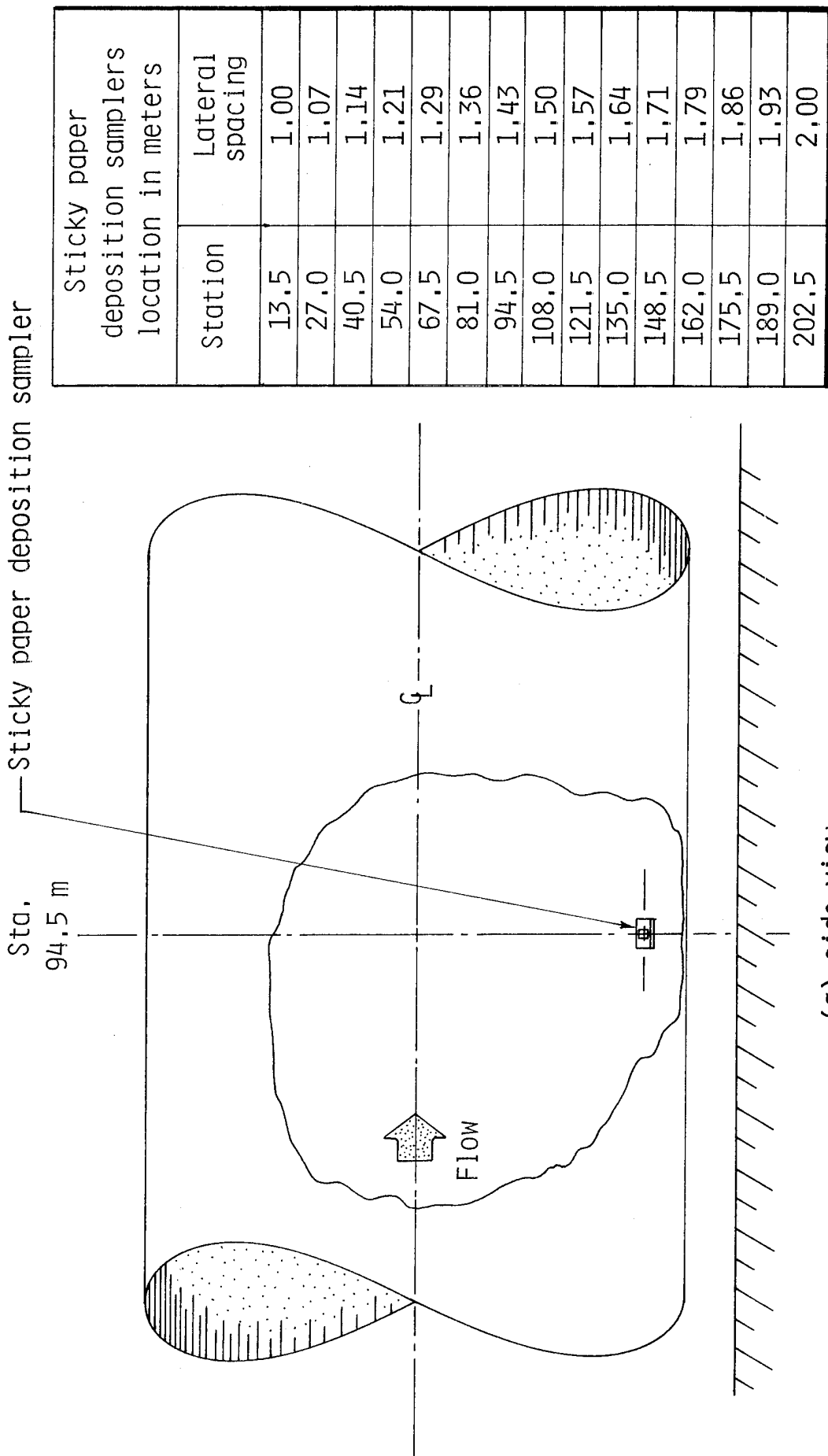
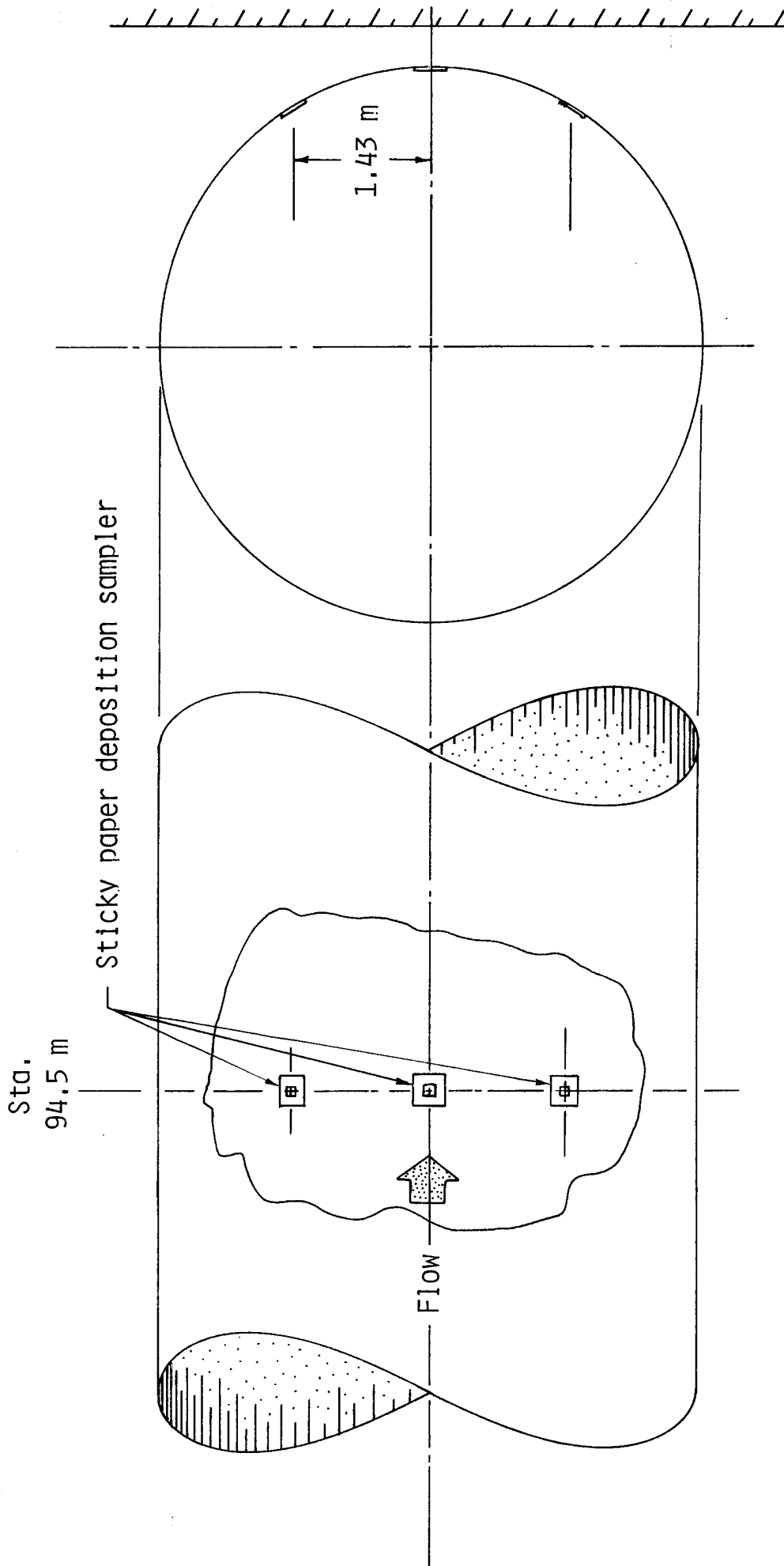

Figure 12. - Location of sticky paper deposition samplers along bottom of shock tube between the fire region and the test section.



(b) Top view

Figure 12. - Concluded.

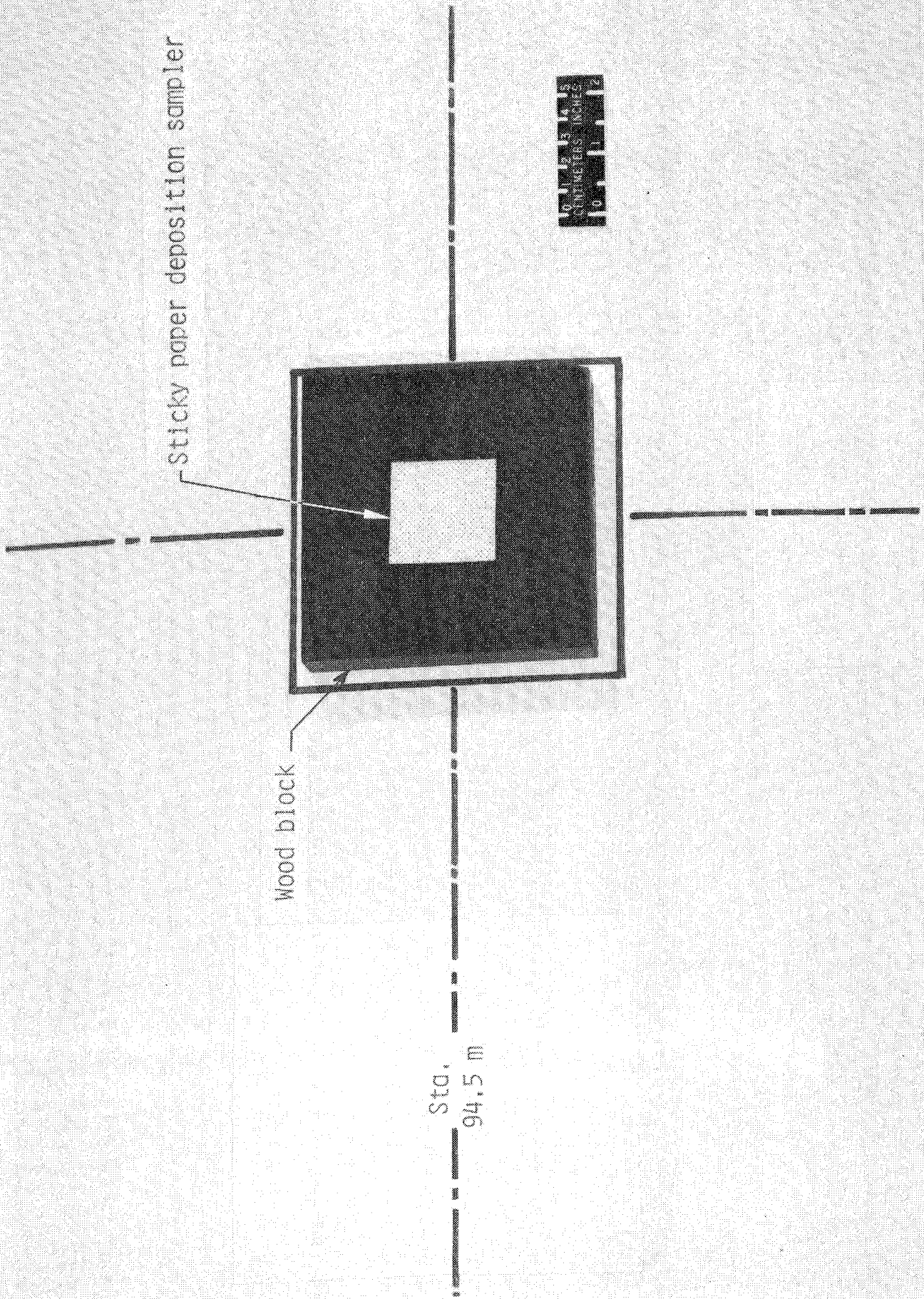
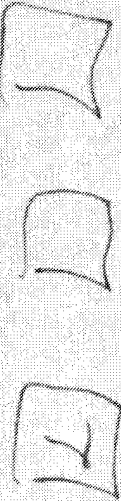

Figure 13. - Typical sticky paper deposition sampler on wood block on bottom of shock tube.

↓ FIRE TEST #53

BLOCKS ON FLOOR



700 FT.

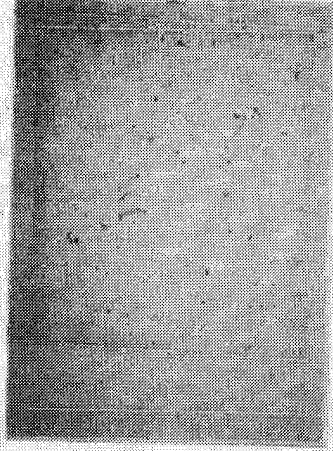

Figure 14.- sticky paper deposition sampler mounted on 35 mm aperture card.



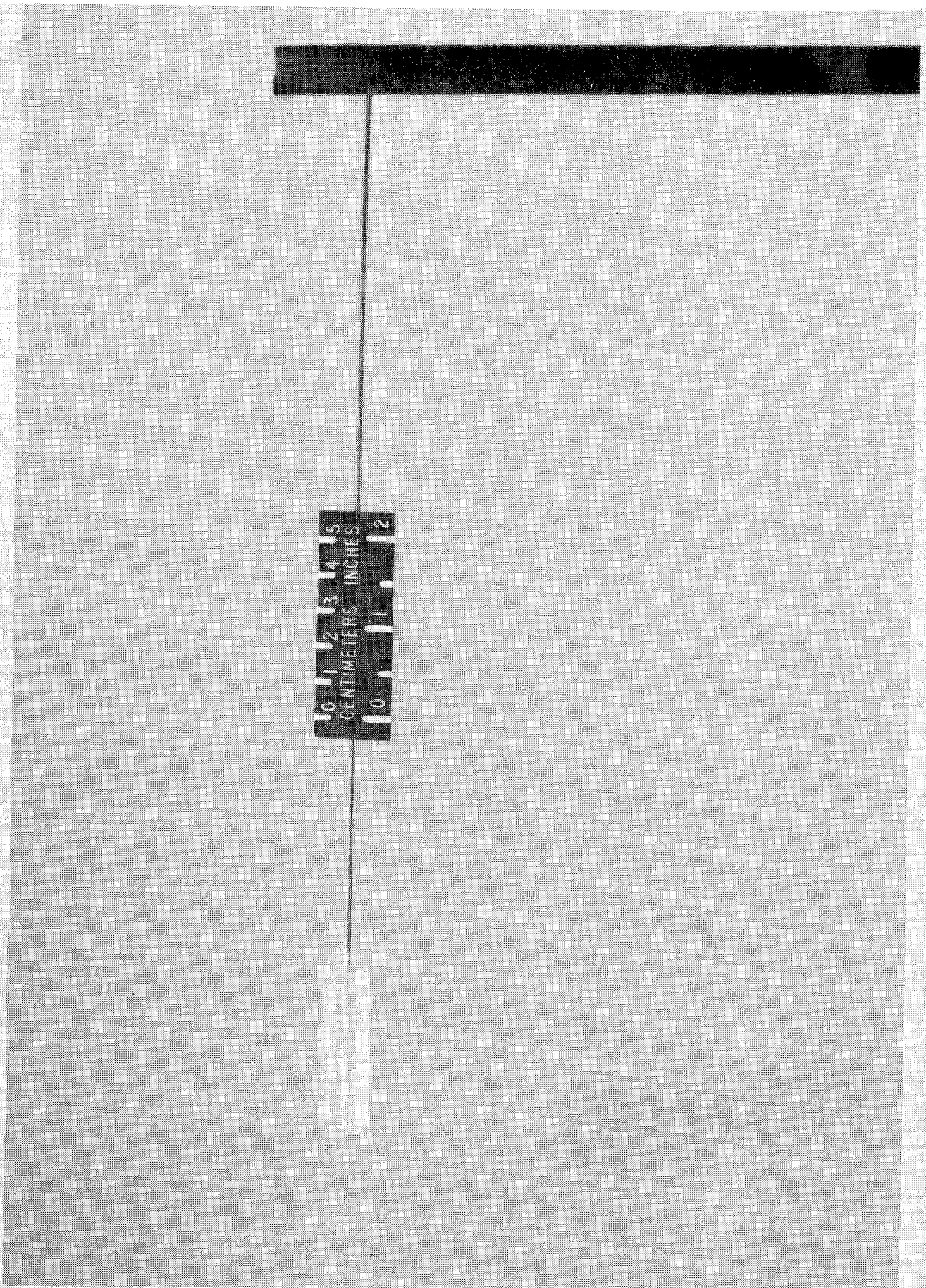

Figure 15. - Typical sticky cylinder exposure sampler wire-mounted in air stream of shock tube.

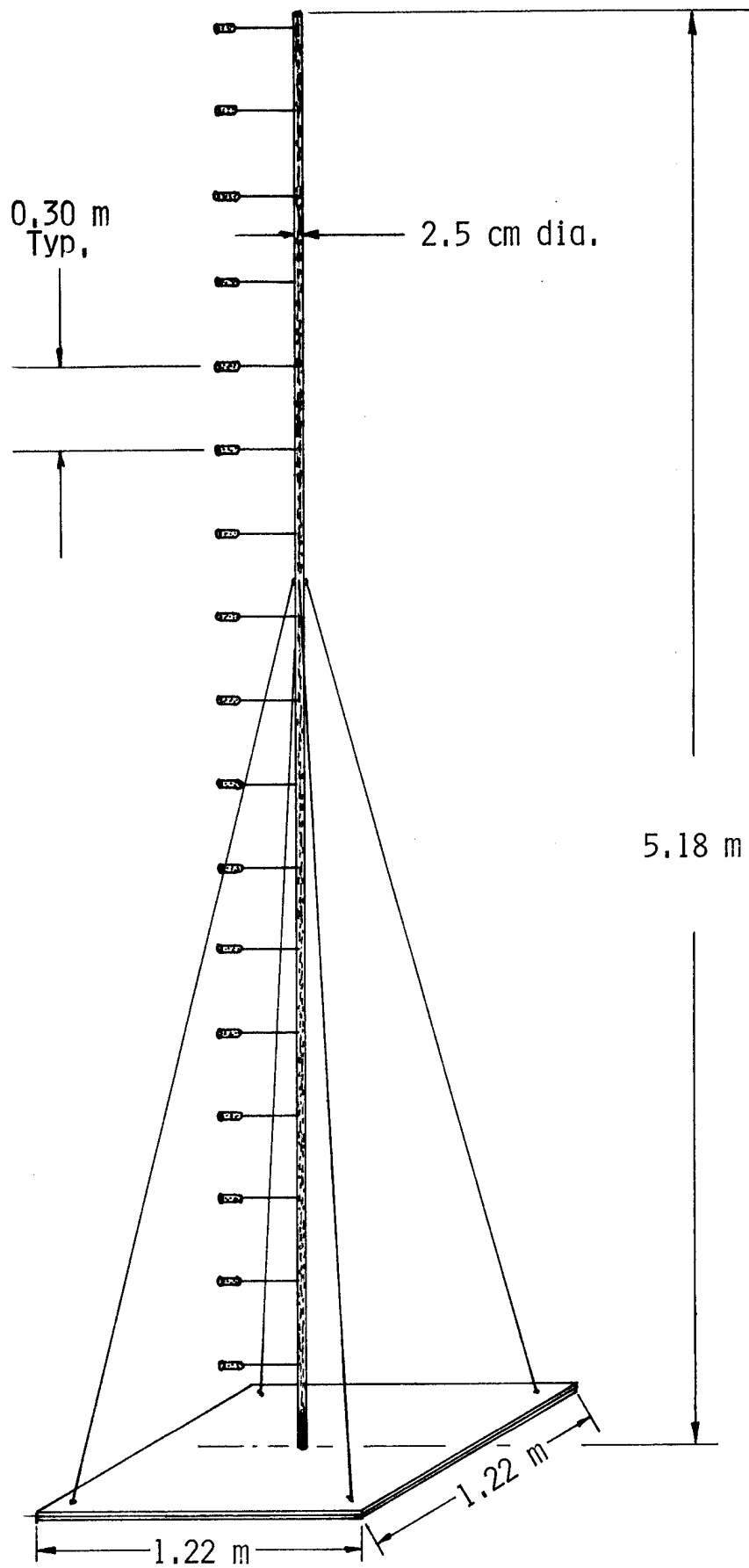
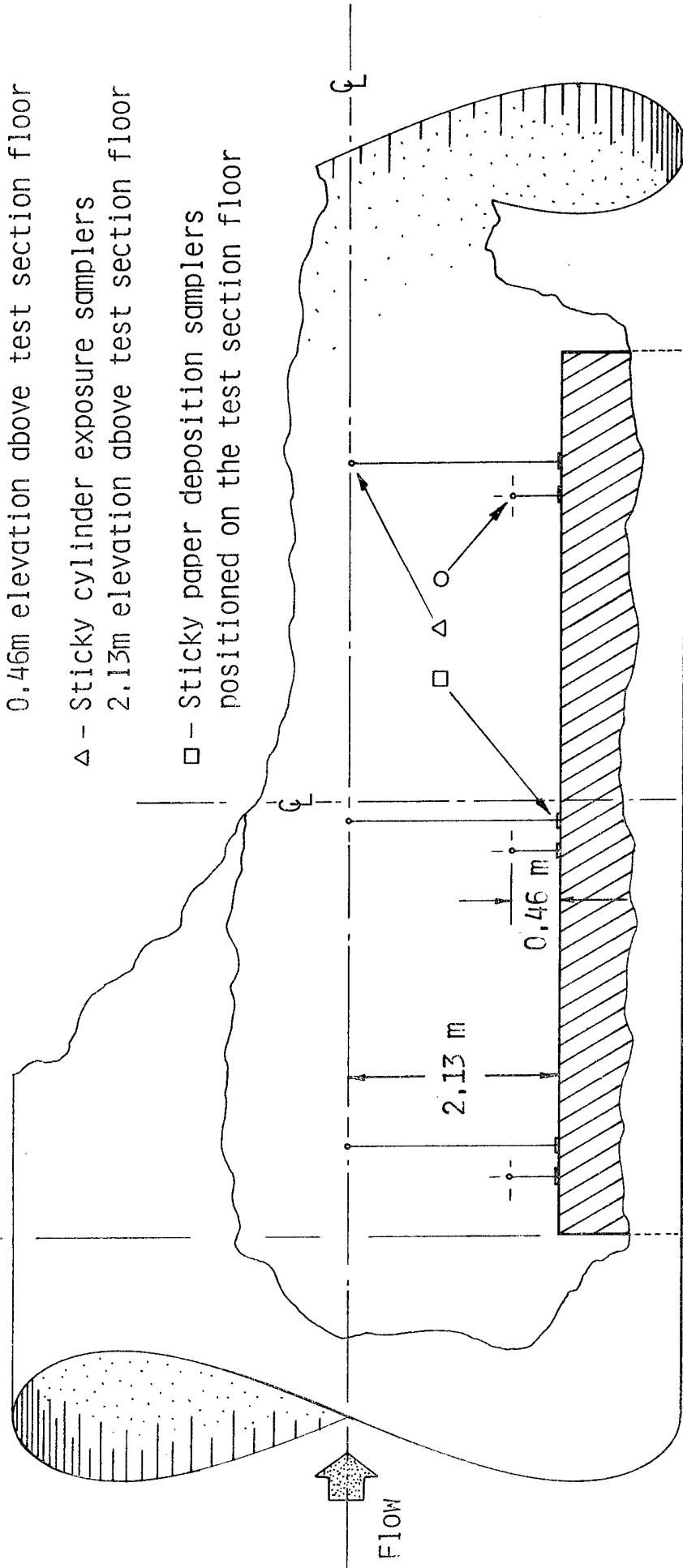

Figure 16. - Tree supporting 17 sticky cylinders to sample for a vertical profile of fiber exposure at the test section.

Sta.  
208 m

- - Sticky cylinder exposure samplers  
0.46m elevation above test section floor
- △ - Sticky cylinder exposure samplers  
2.13m elevation above test section floor
- - Sticky paper deposition samplers  
positioned on the test section floor



(a) Side view

Figure 17. - Location of individual sticky samplers above the test section floor.

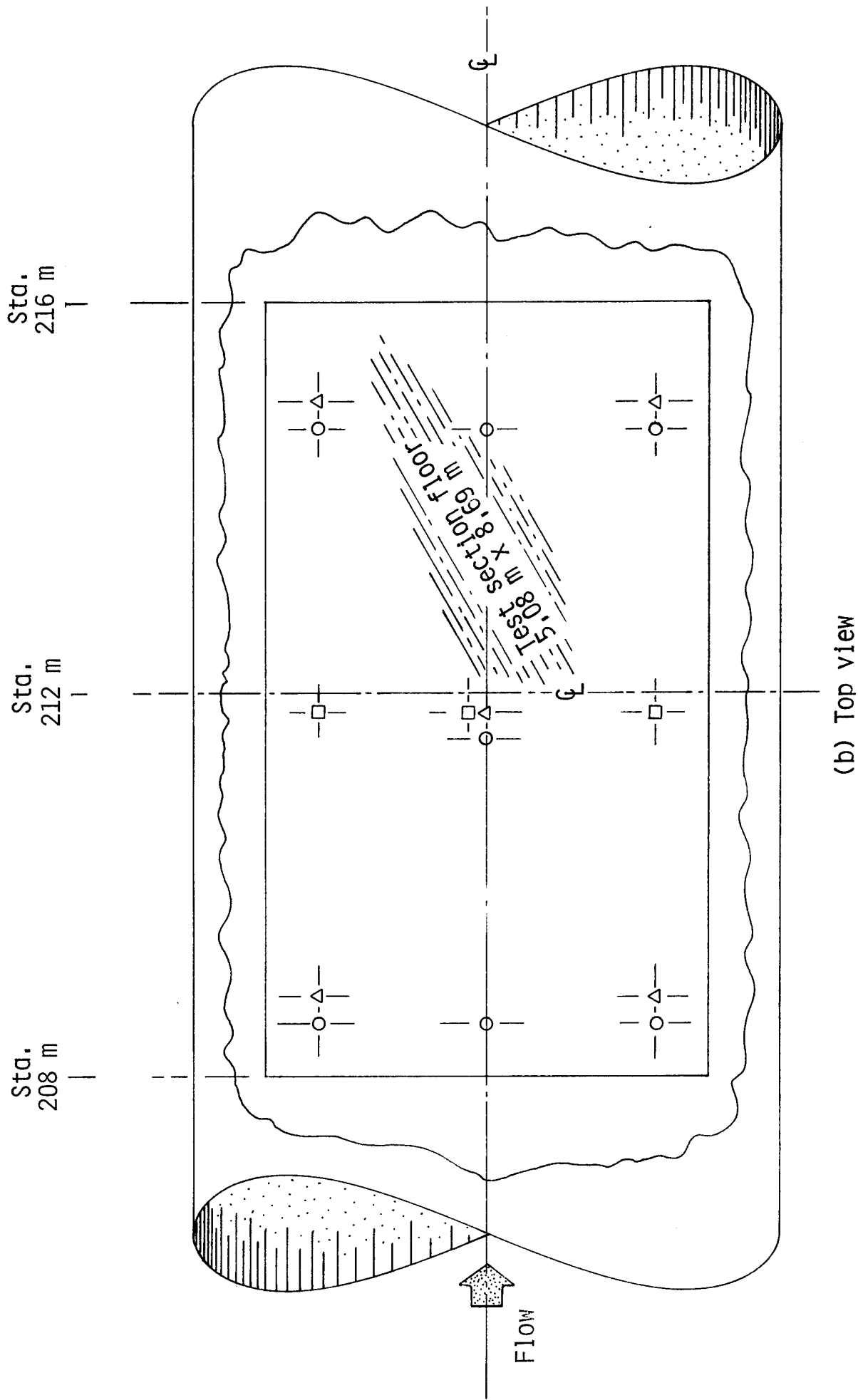

(b) Top view

Figure 17. - Concluded.

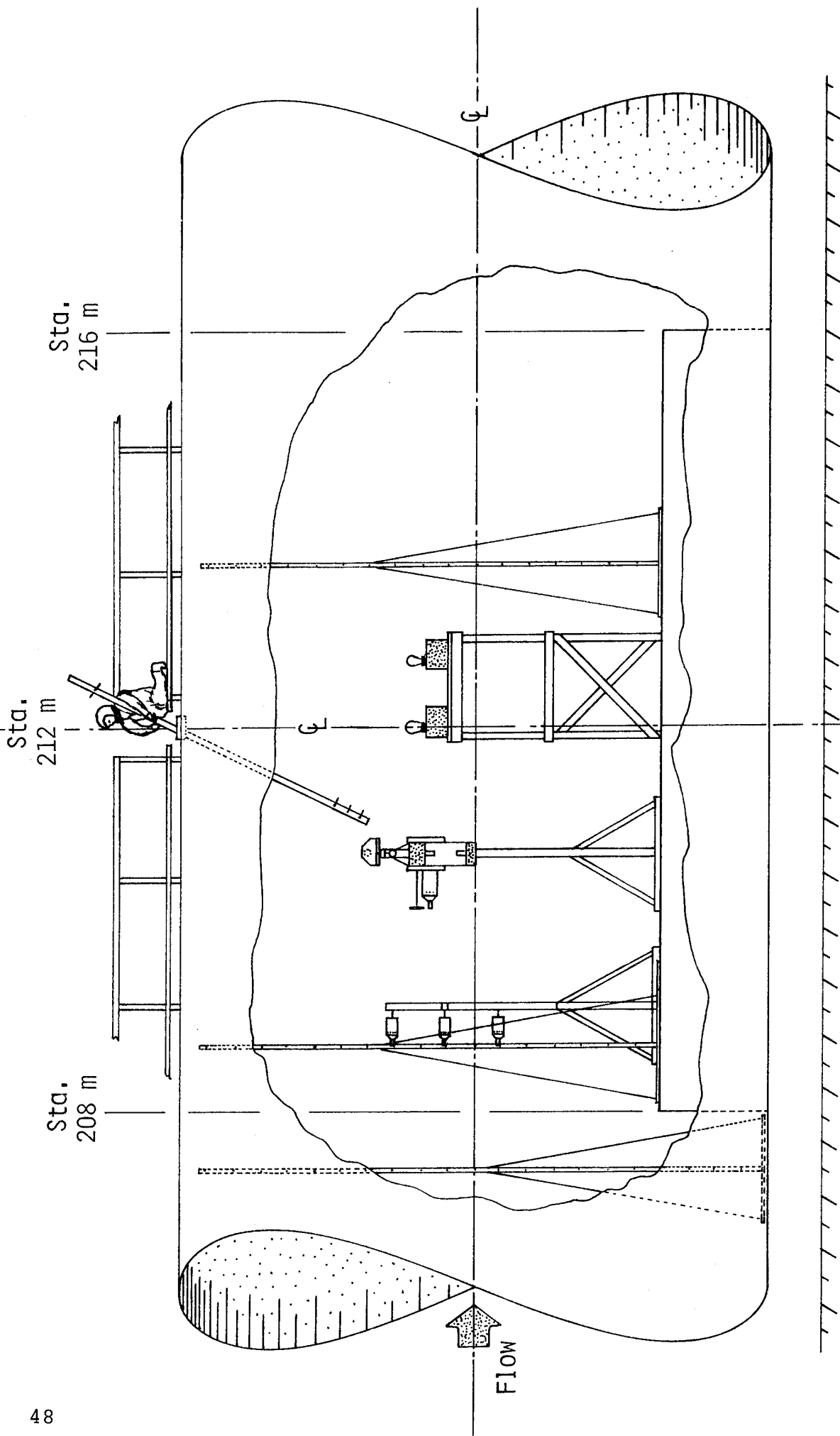

(a) Side view,

Figure 18. - Location of various stand-supported fiber collecting and sensing instrumentation at the test section,

Sta.  
216 m

Sta.  
212 m

Sta.  
208 m

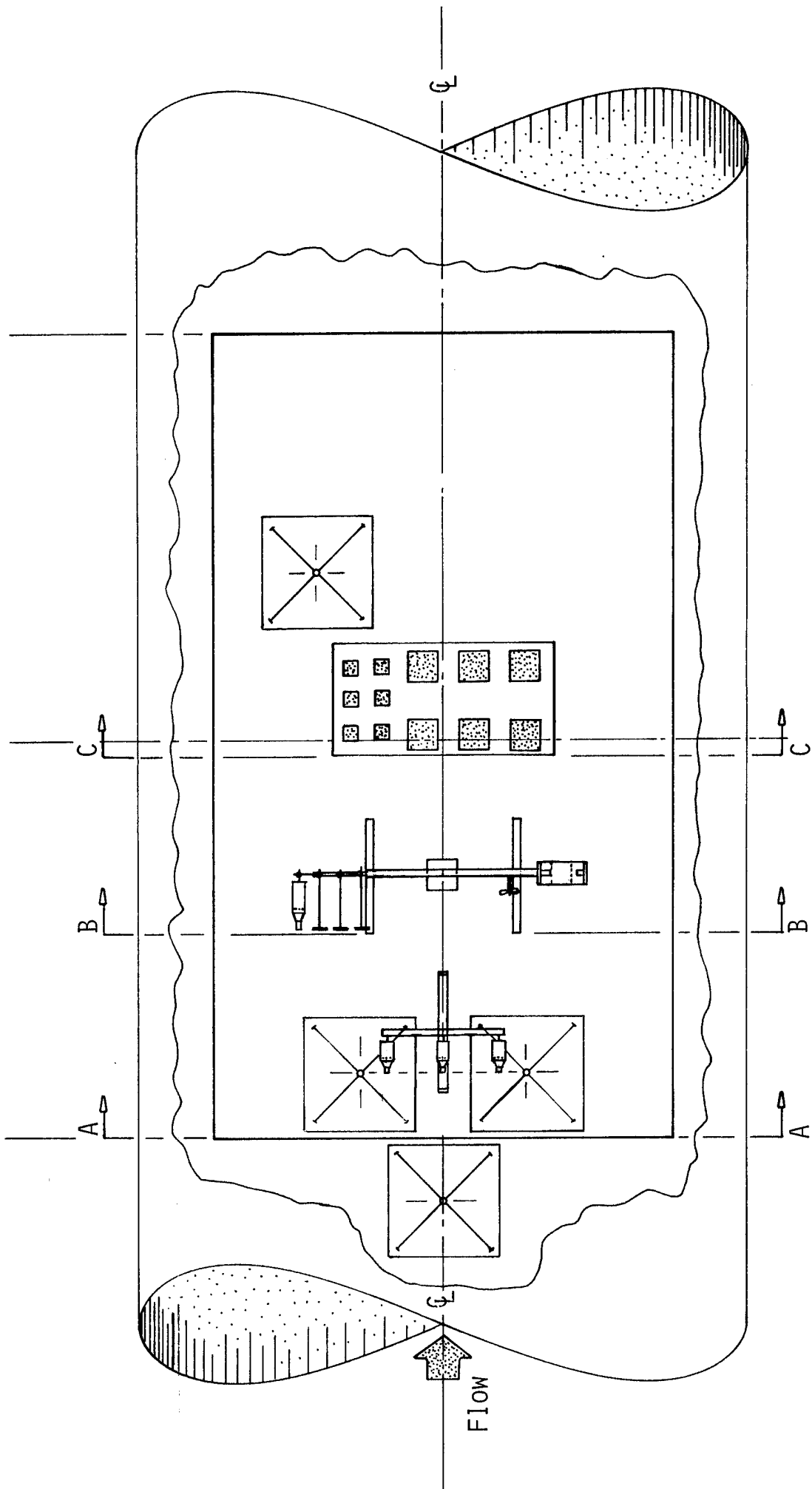

(b) Top view.

Figure 18. - Continued.

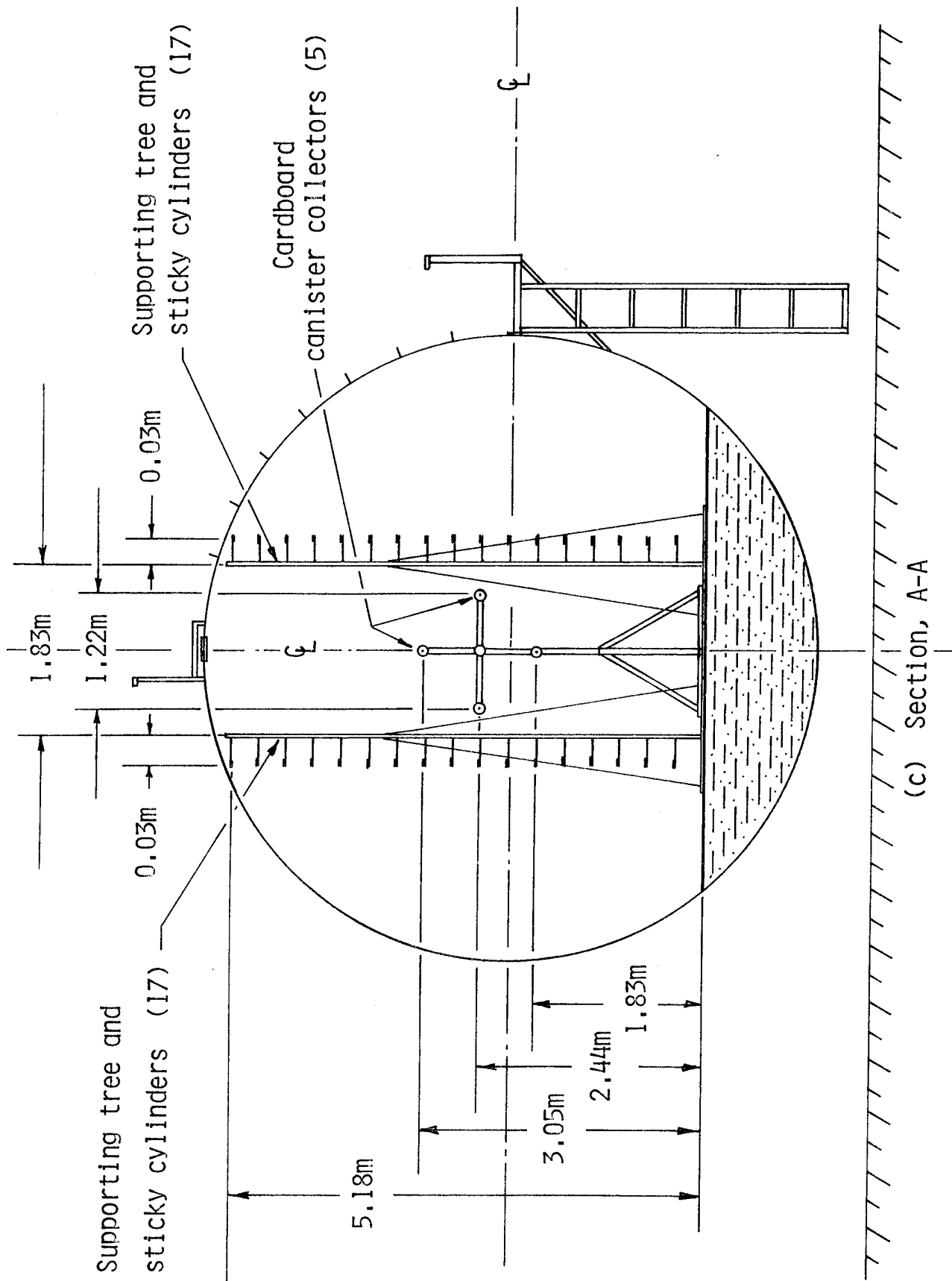

(c) Section, A-A

Figure 18. - Continued,

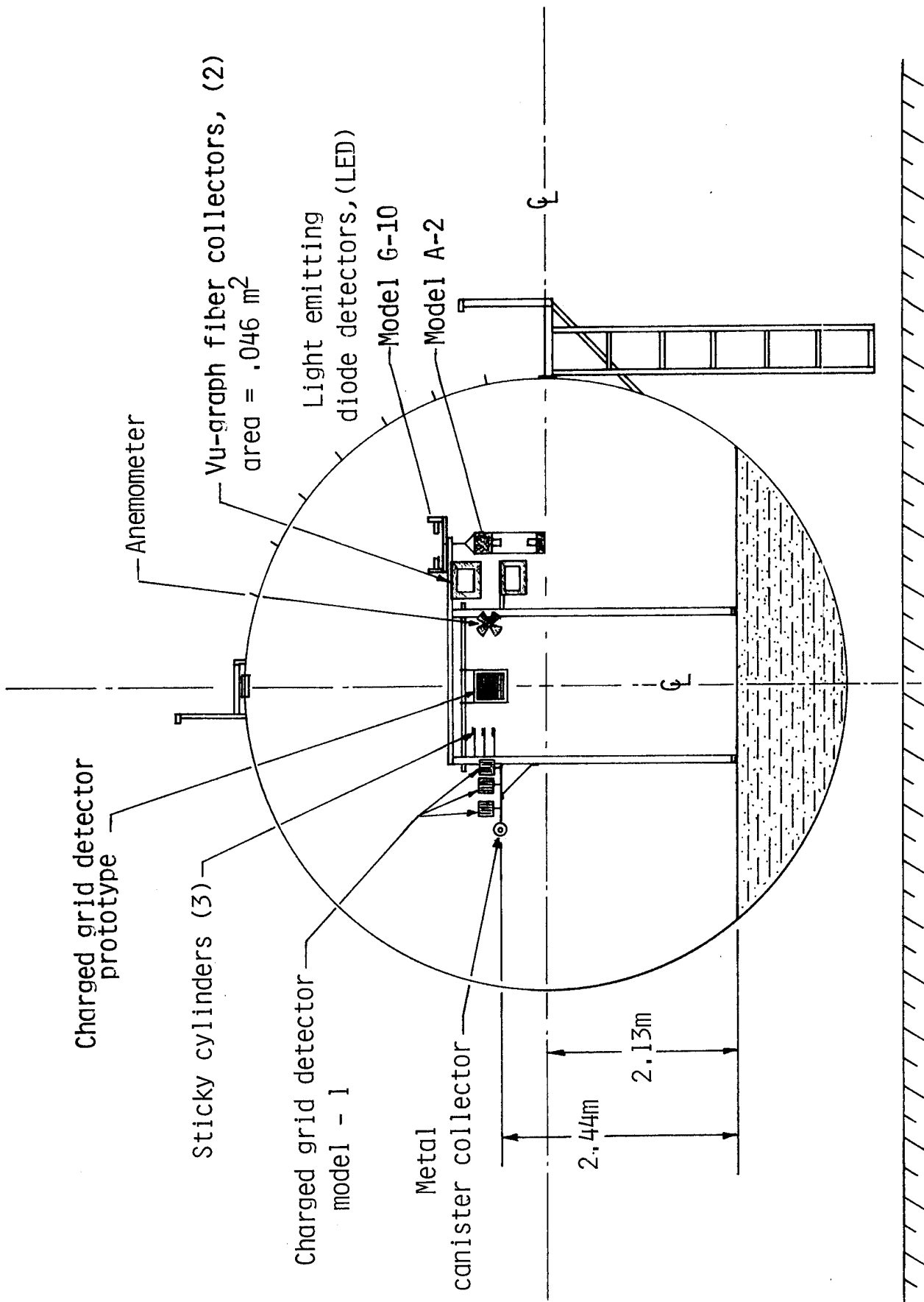

Figure 18. - Continued.



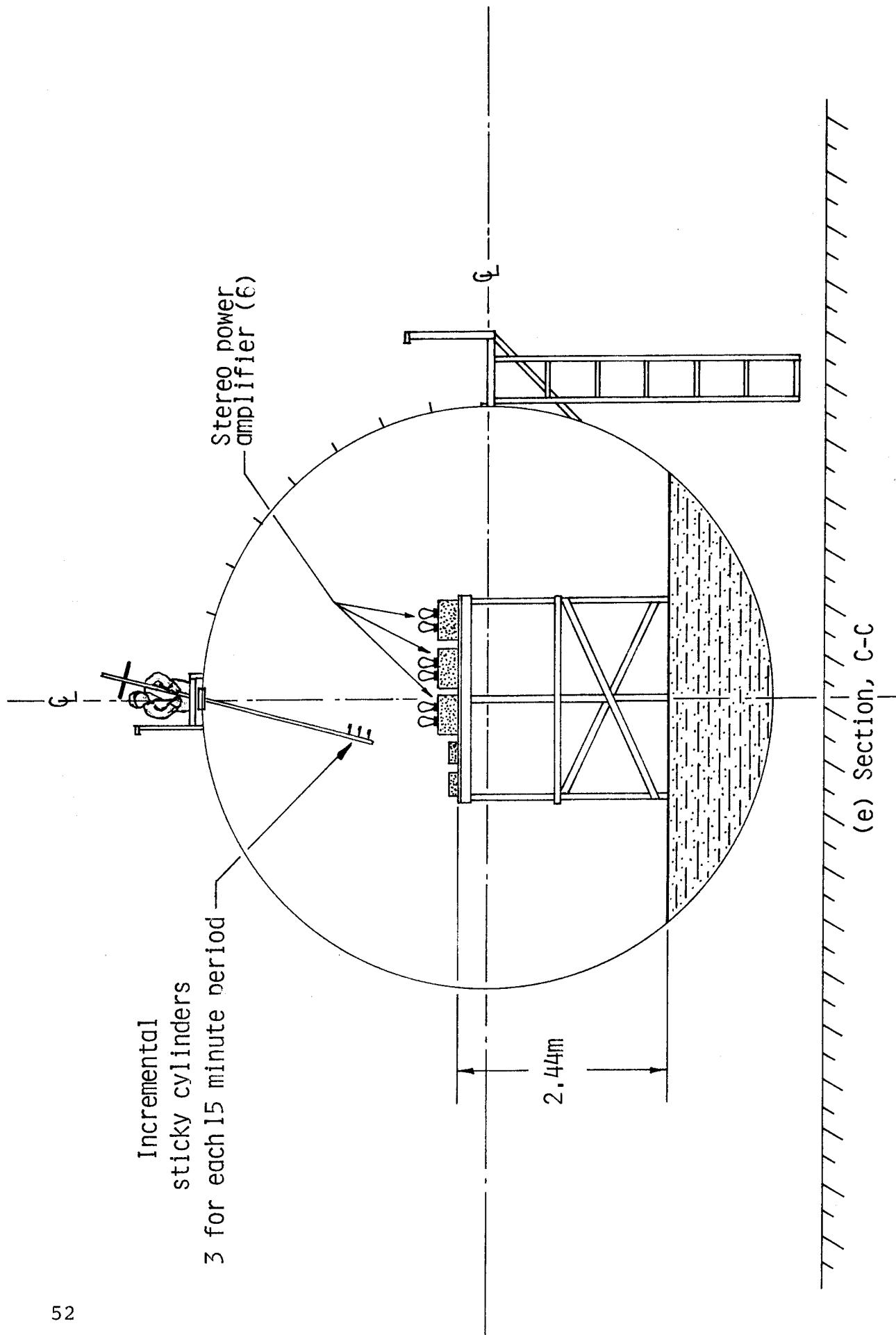

Figure 18.- Concluded

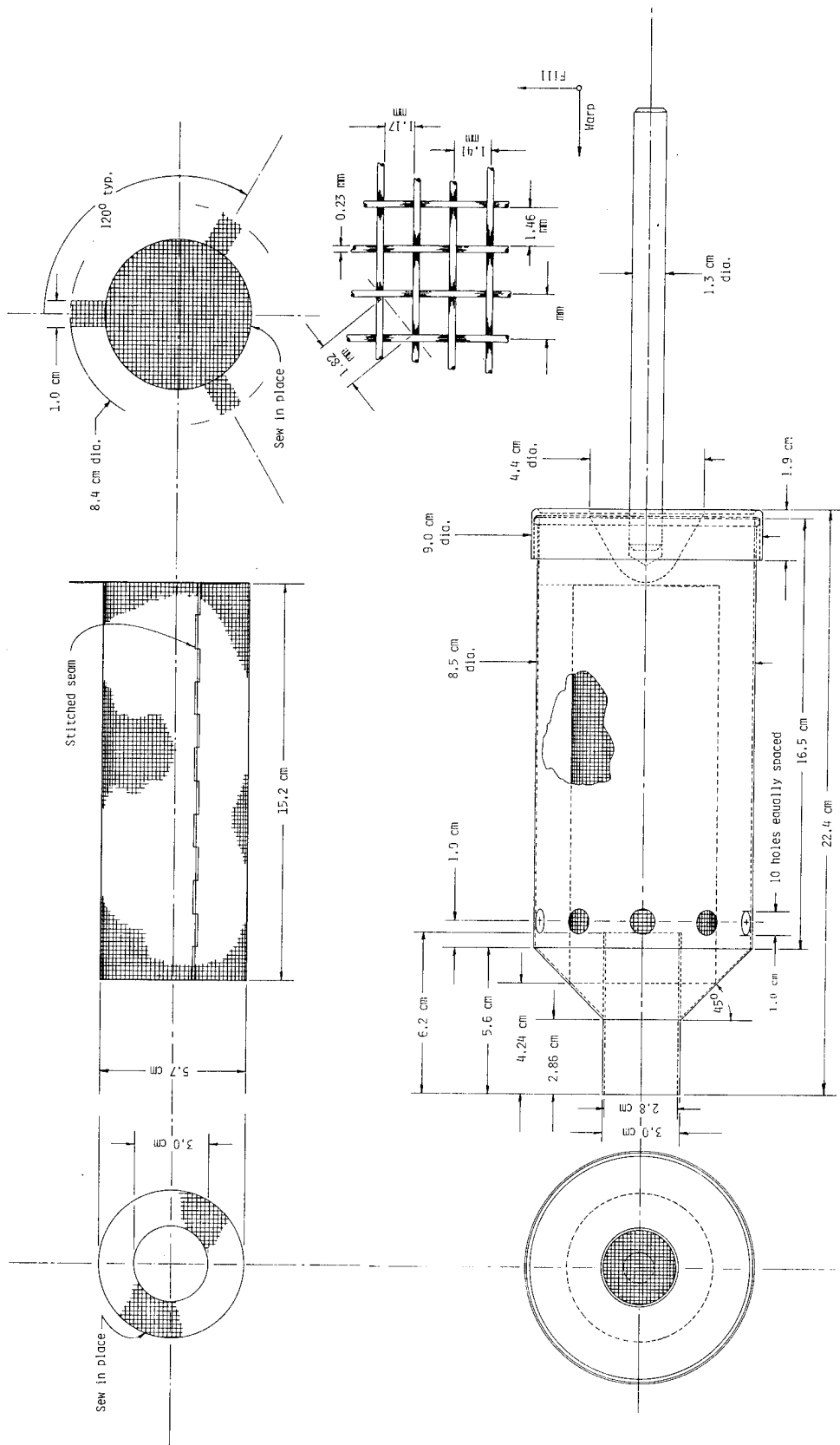

Figure 19.- Canister collector.

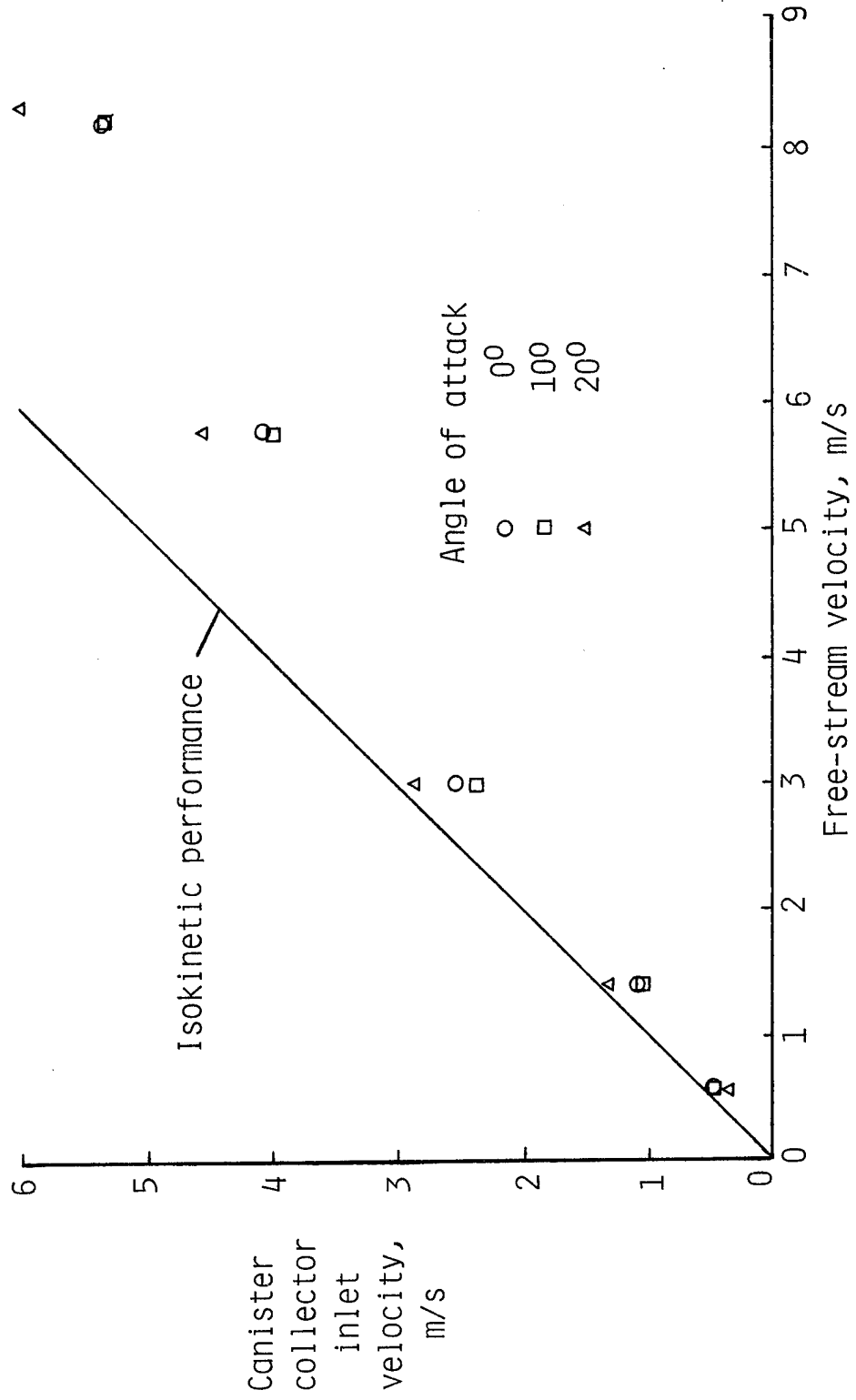

Figure 20.- Wind tunnel calibration for canister collector.

NASA  
L-80-1895

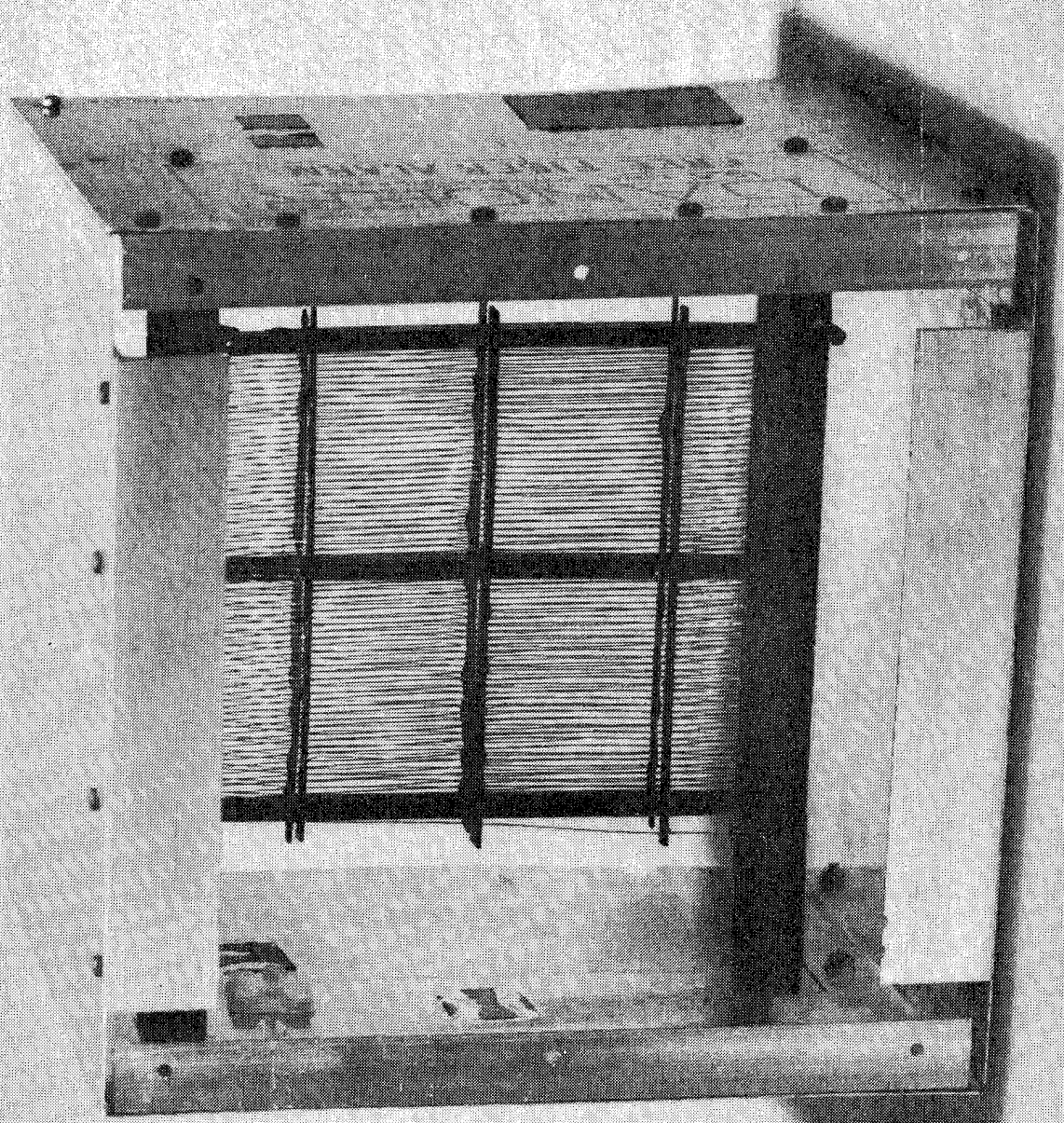

Figure 21. - Prototype model of a charged grid detector for sensing the time dependent passage of fibers.

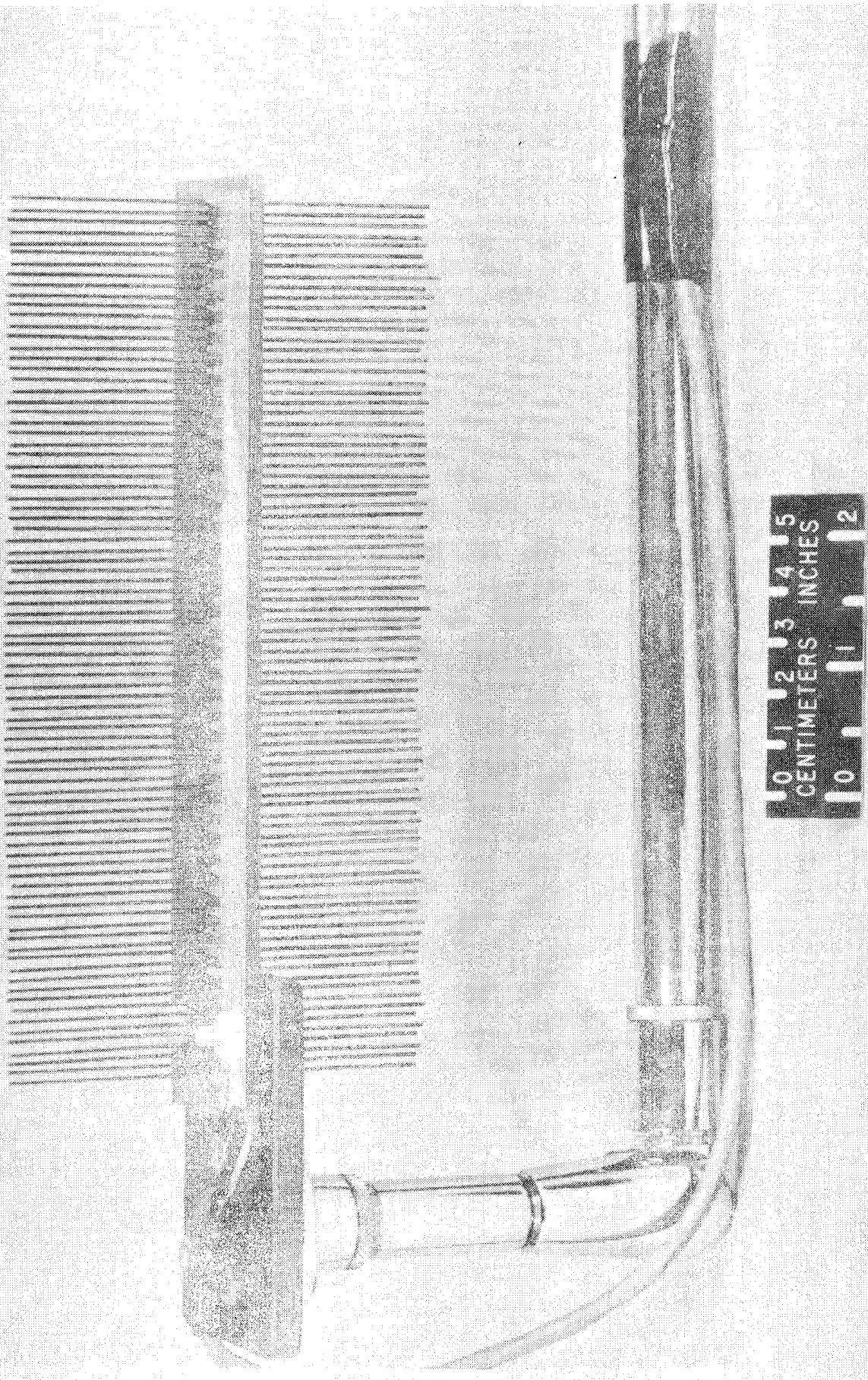

Figure 22. - Charged grid detector, model 1, for sensing the time dependent passage of fibers and measuring fiber resistance.



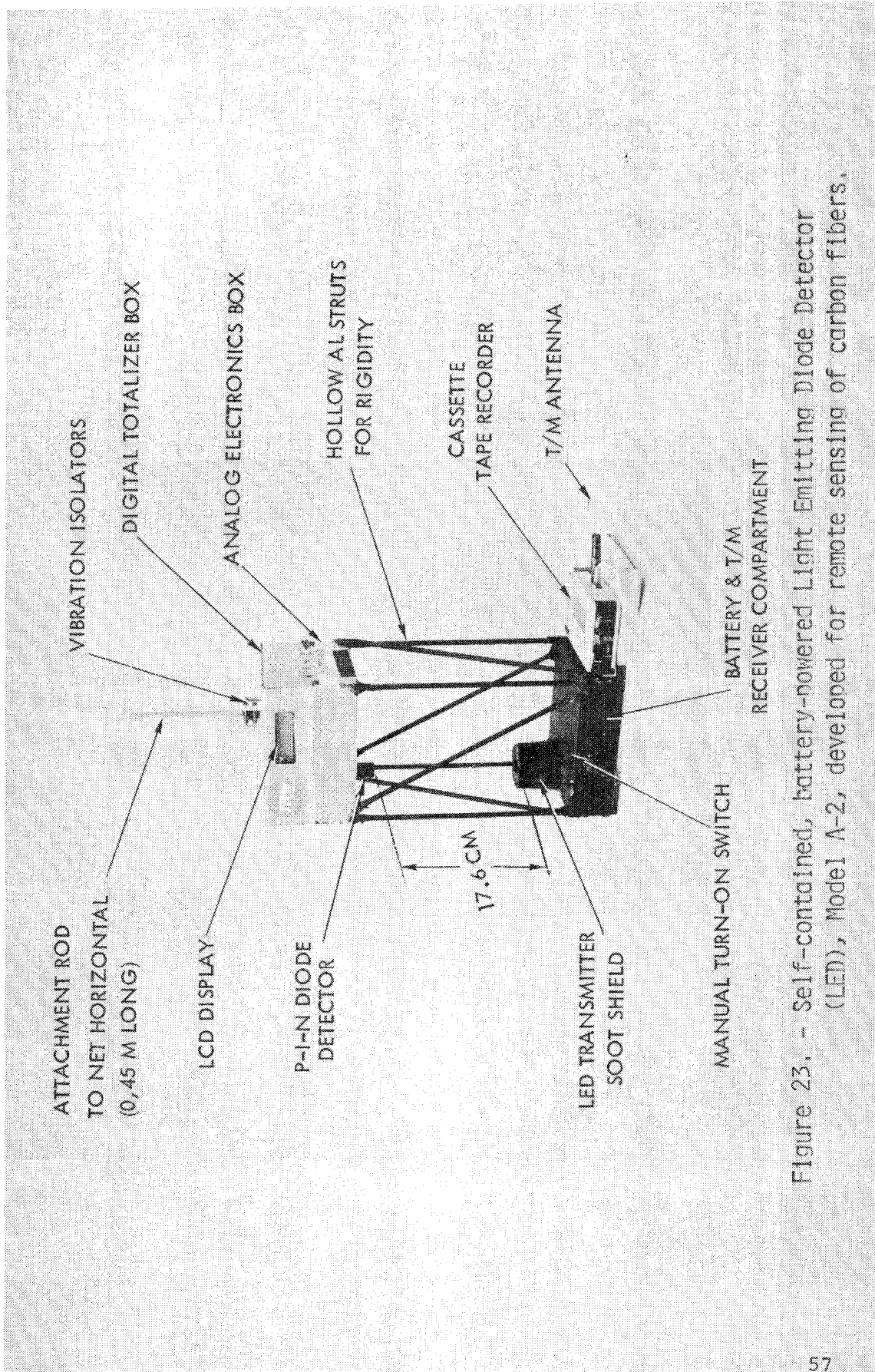

Figure 23. - Self-contained, battery-powered Light Emitting Diode Detector (LED), Model A-2, developed for remote sensing of carbon fibers.

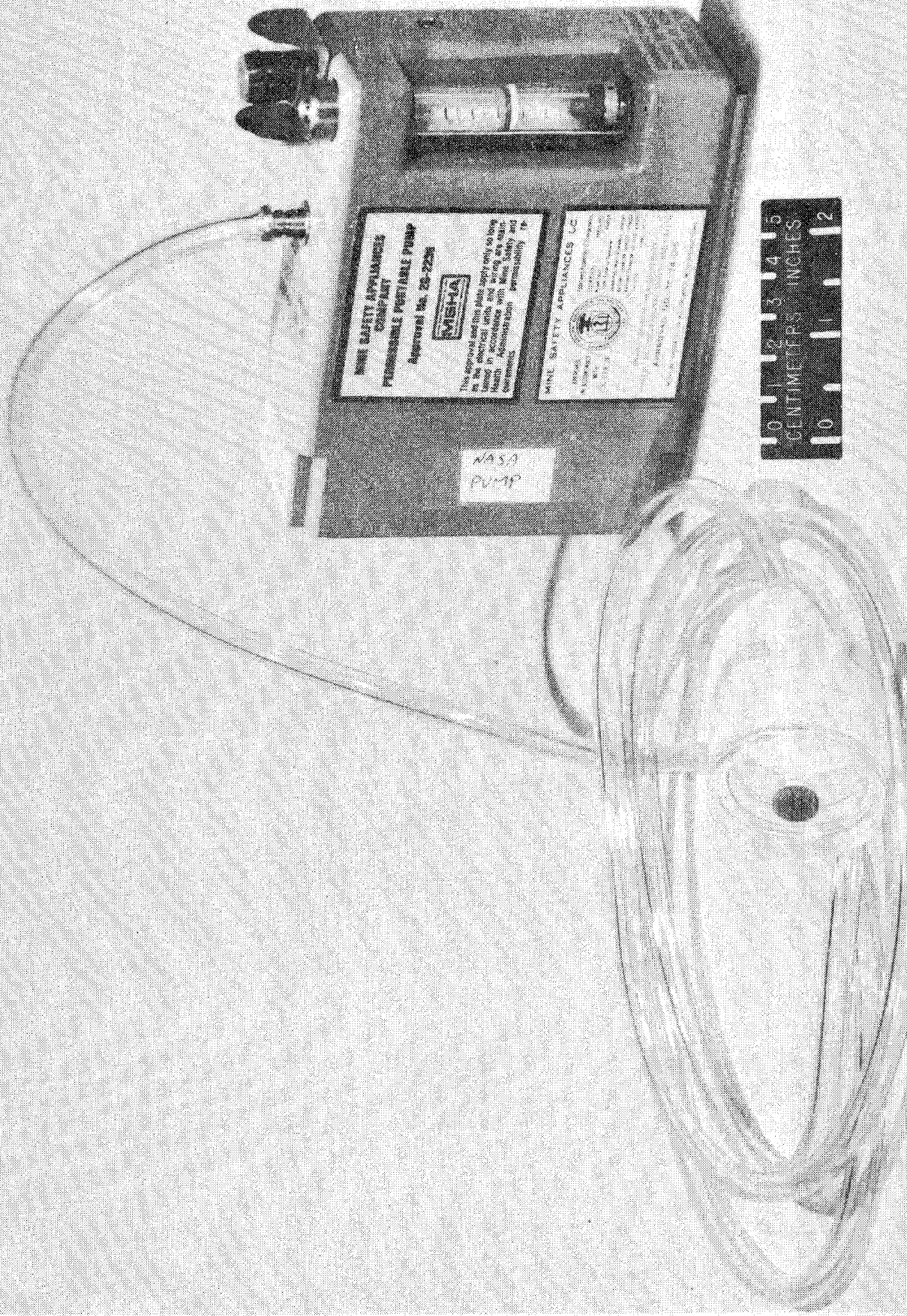
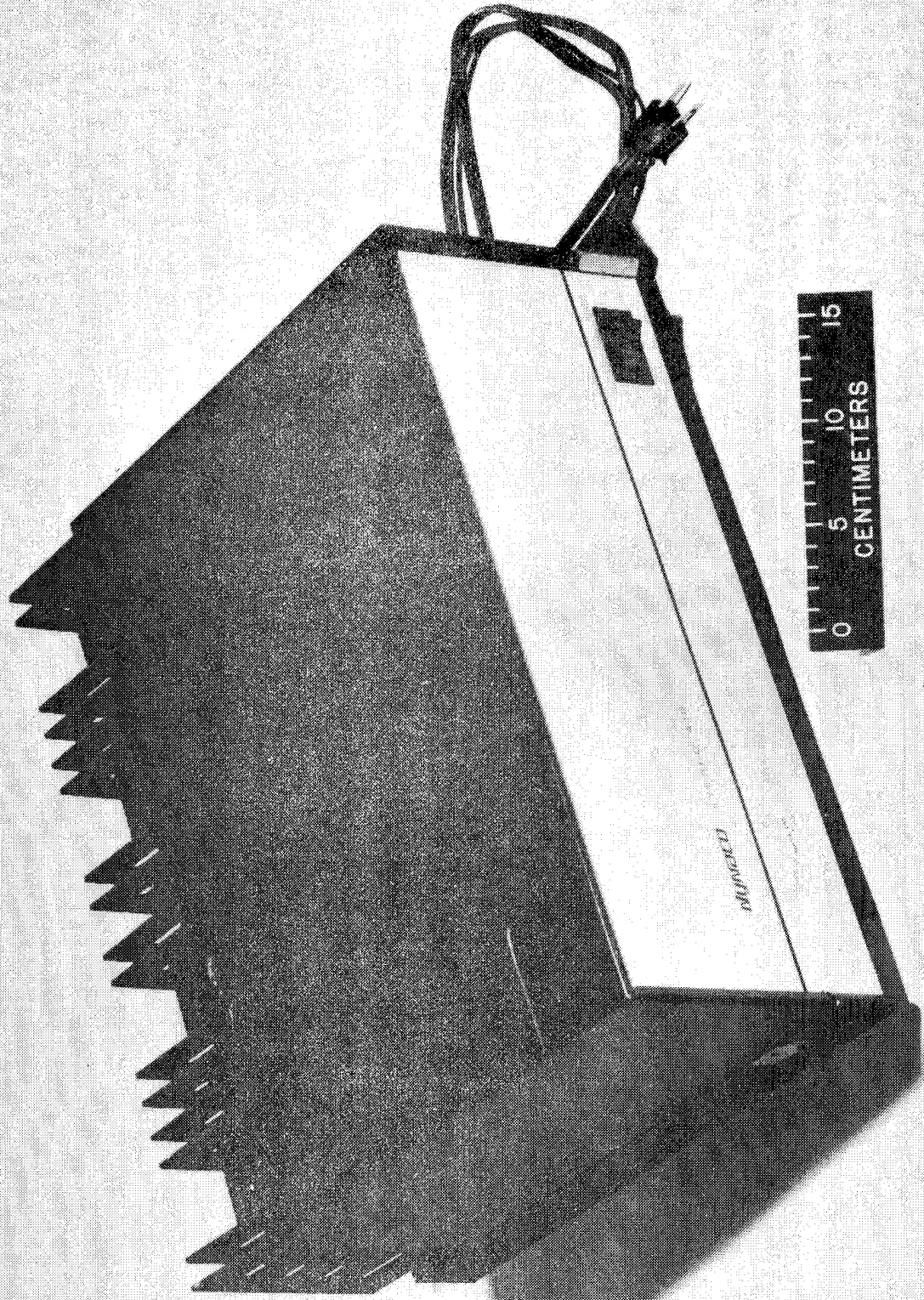

Figure 24. - Millipore filter sampler equipped with battery-powered portable vacuum pump.



(a) In normal case,

Figure 25. - Stereo power amplifier used for electronic equipment exposure to fire-released carbon fibers.



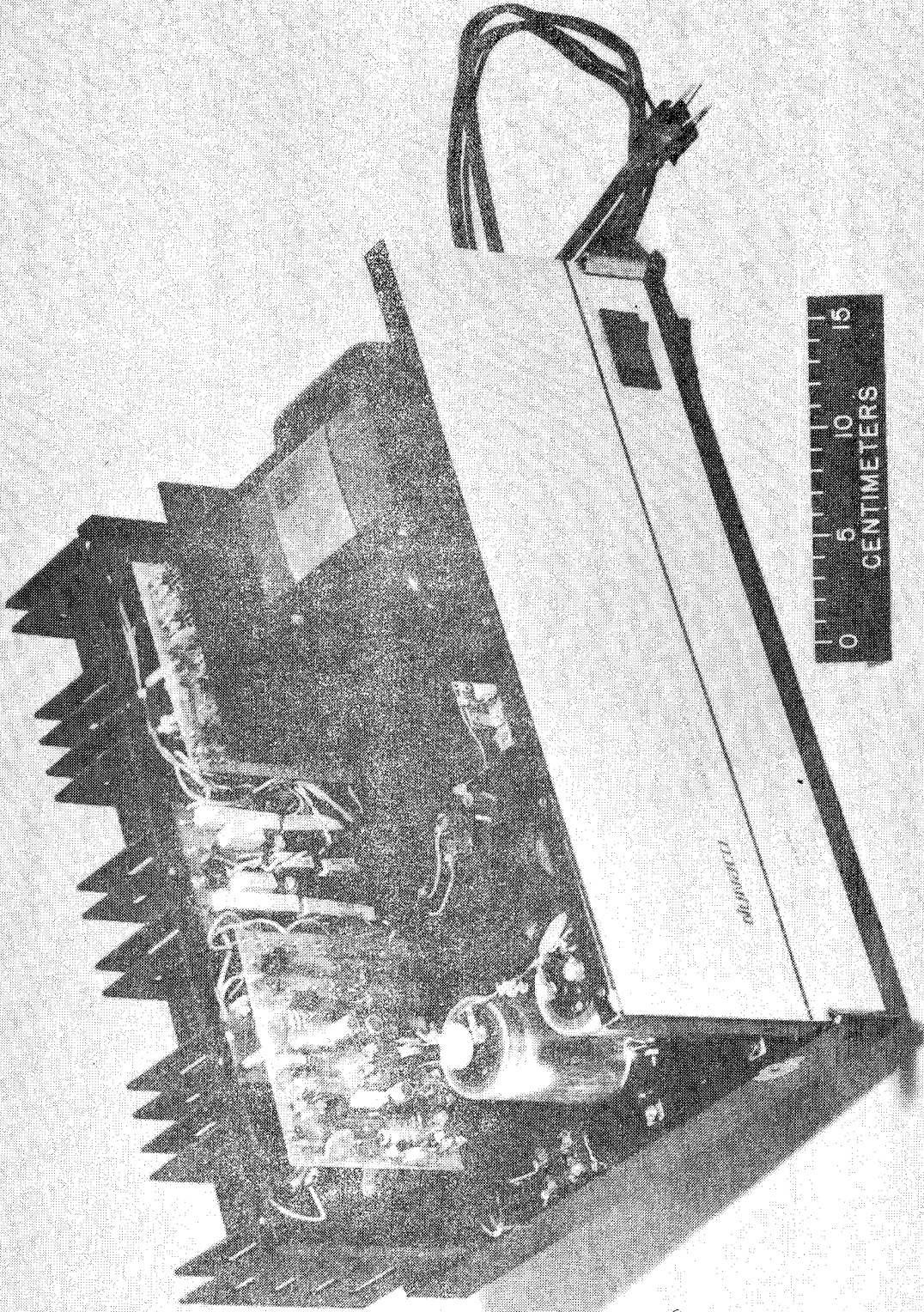

(b) Case removed,

Figure 25. - Continued.

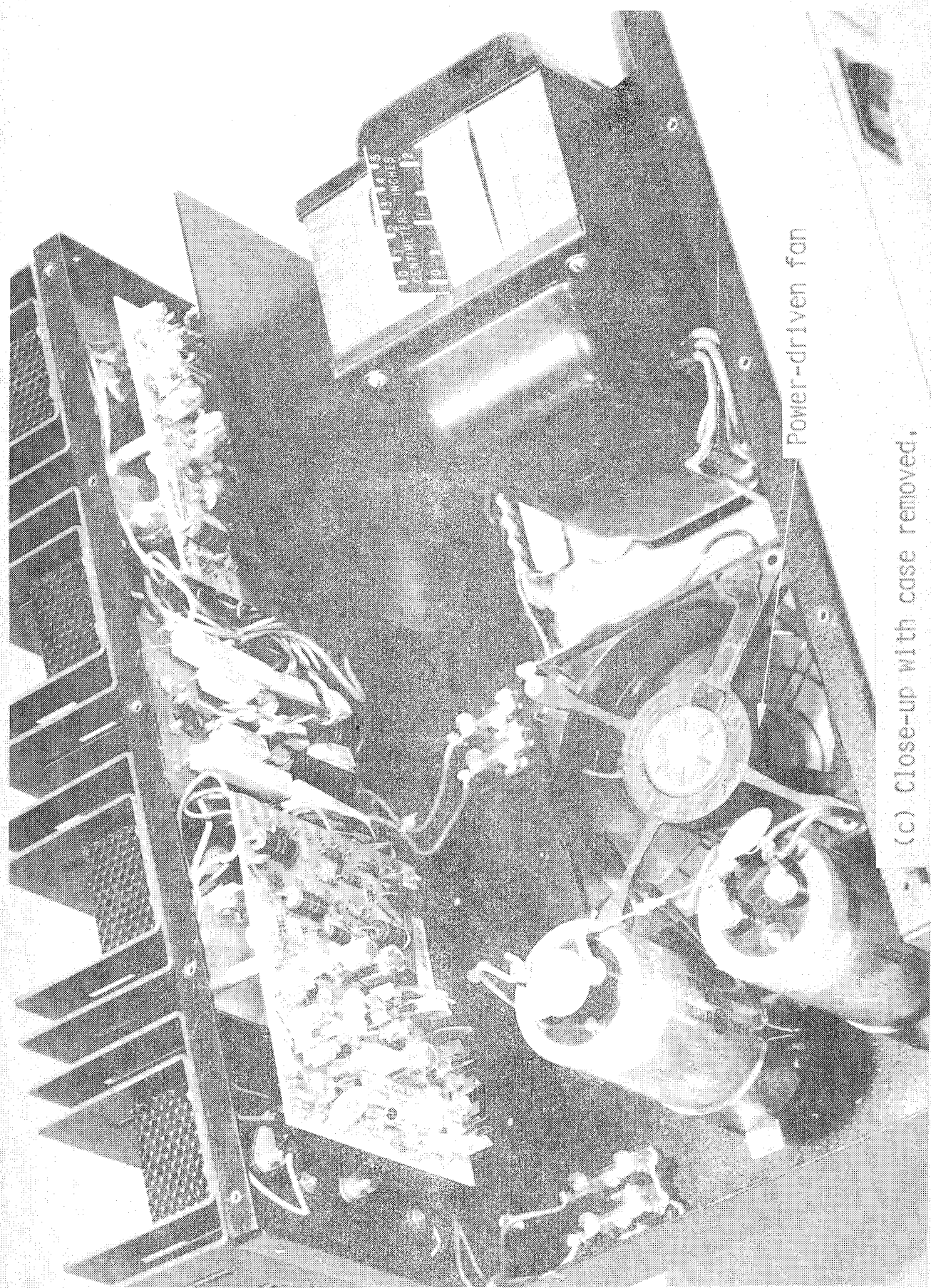

Power-driven fan

(c) Close-up with case removed.

Figure 25. - Continued.



(d) Close-up of printed circuit board.

Figure 25. - Concluded.



NASA  
L-79-5218

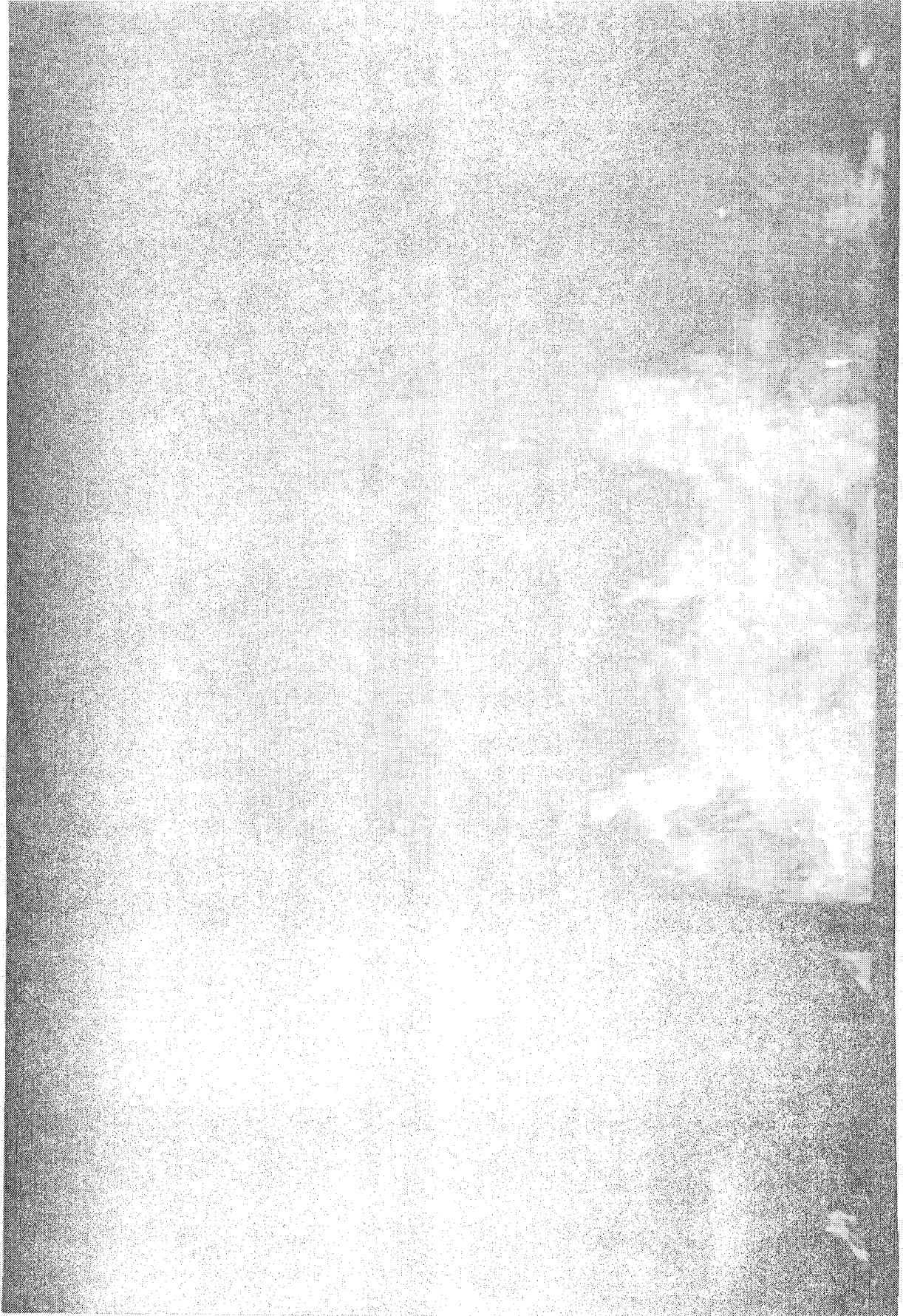

Figure 26.- Carbon-fiber-epoxy composite material in rotating basket being burned in aviation jet fuel fire.

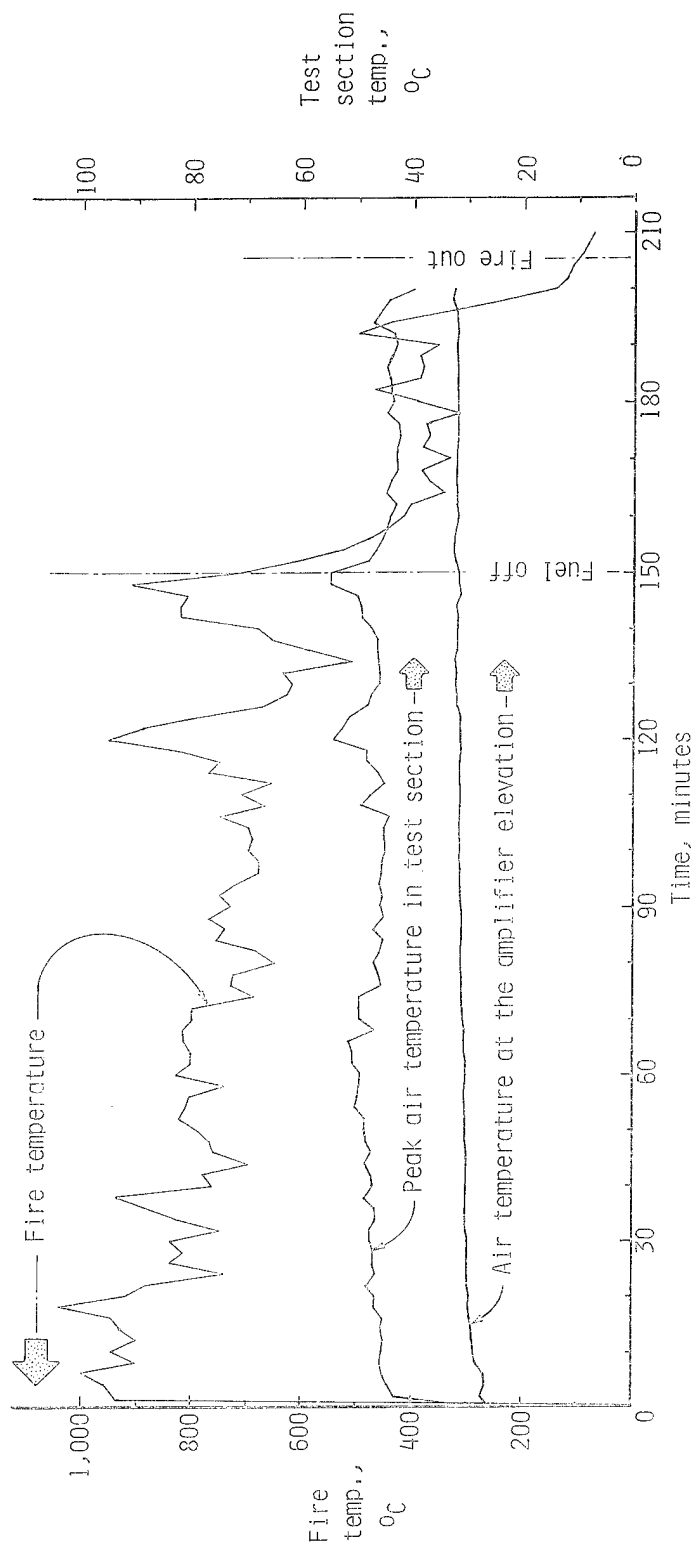

Figure 27. - Temperature histories during test 53 in the flames at the rotating specimen basket and in the test section.

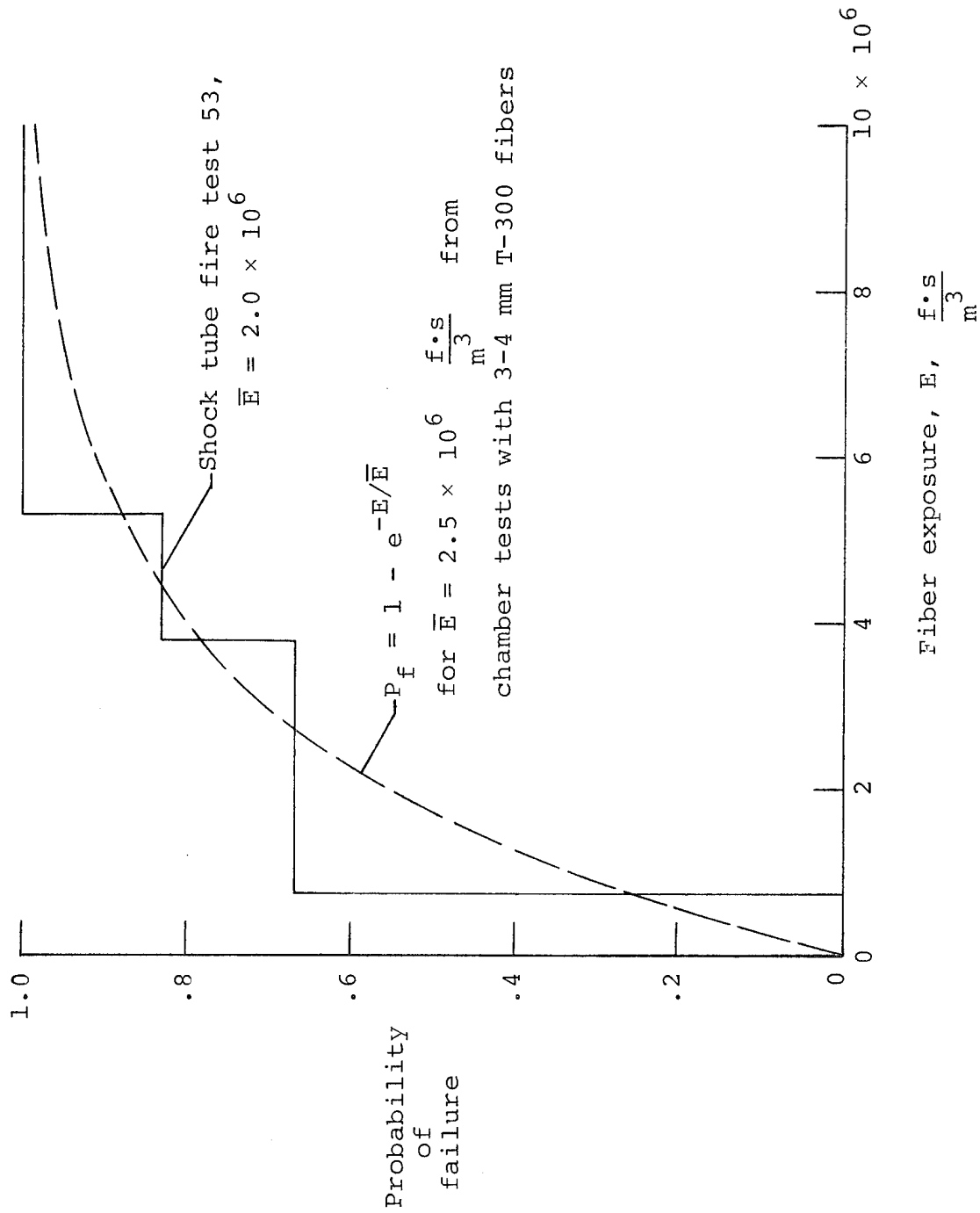

Figure 28.- Electronic equipment failures from exposures to fire-released and to virgin carbon fibers.

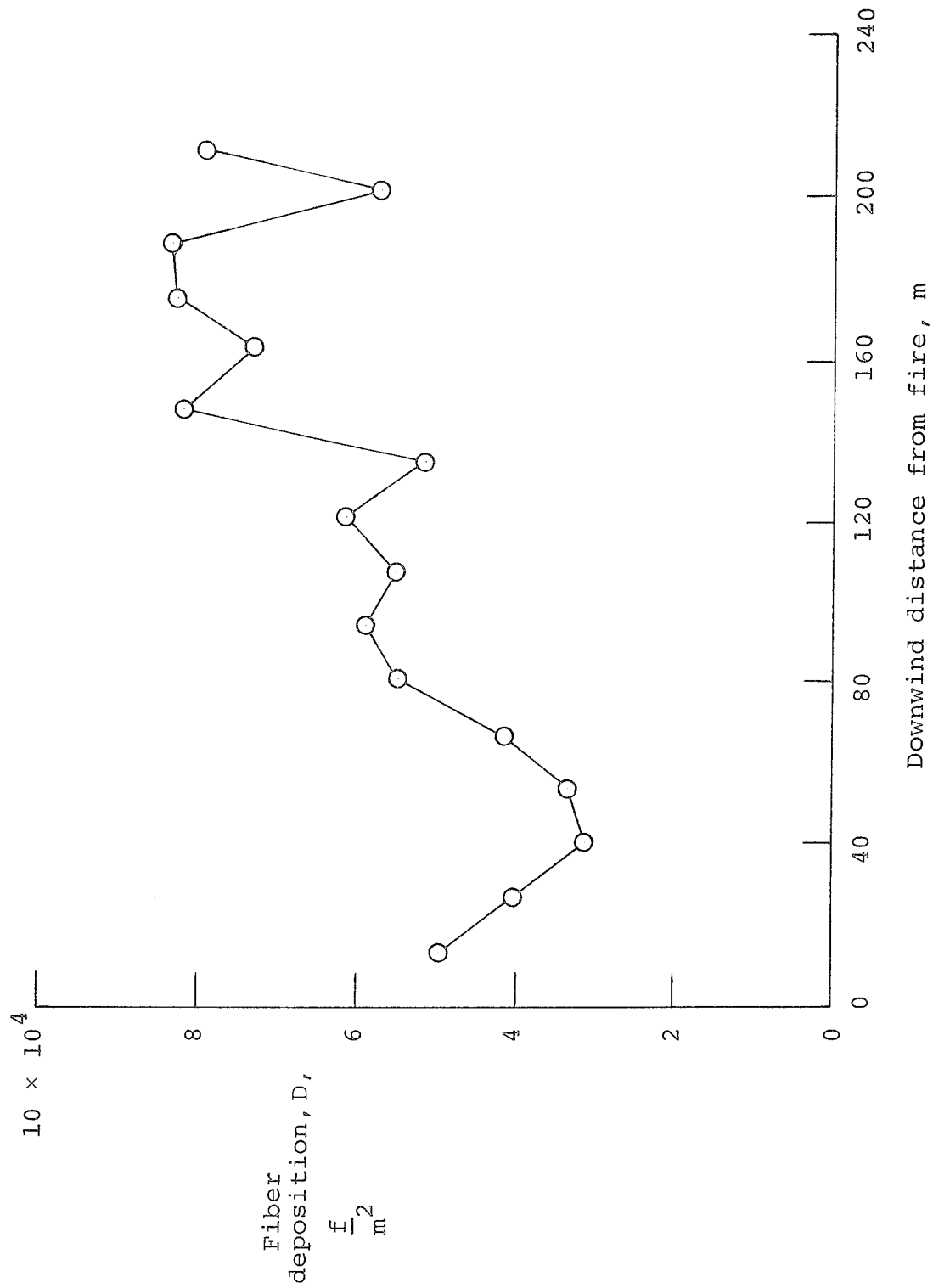

Figure 29.- Deposition of fibers greater than 1 mm in length at various locations on the floor of the shock tube in test 53.

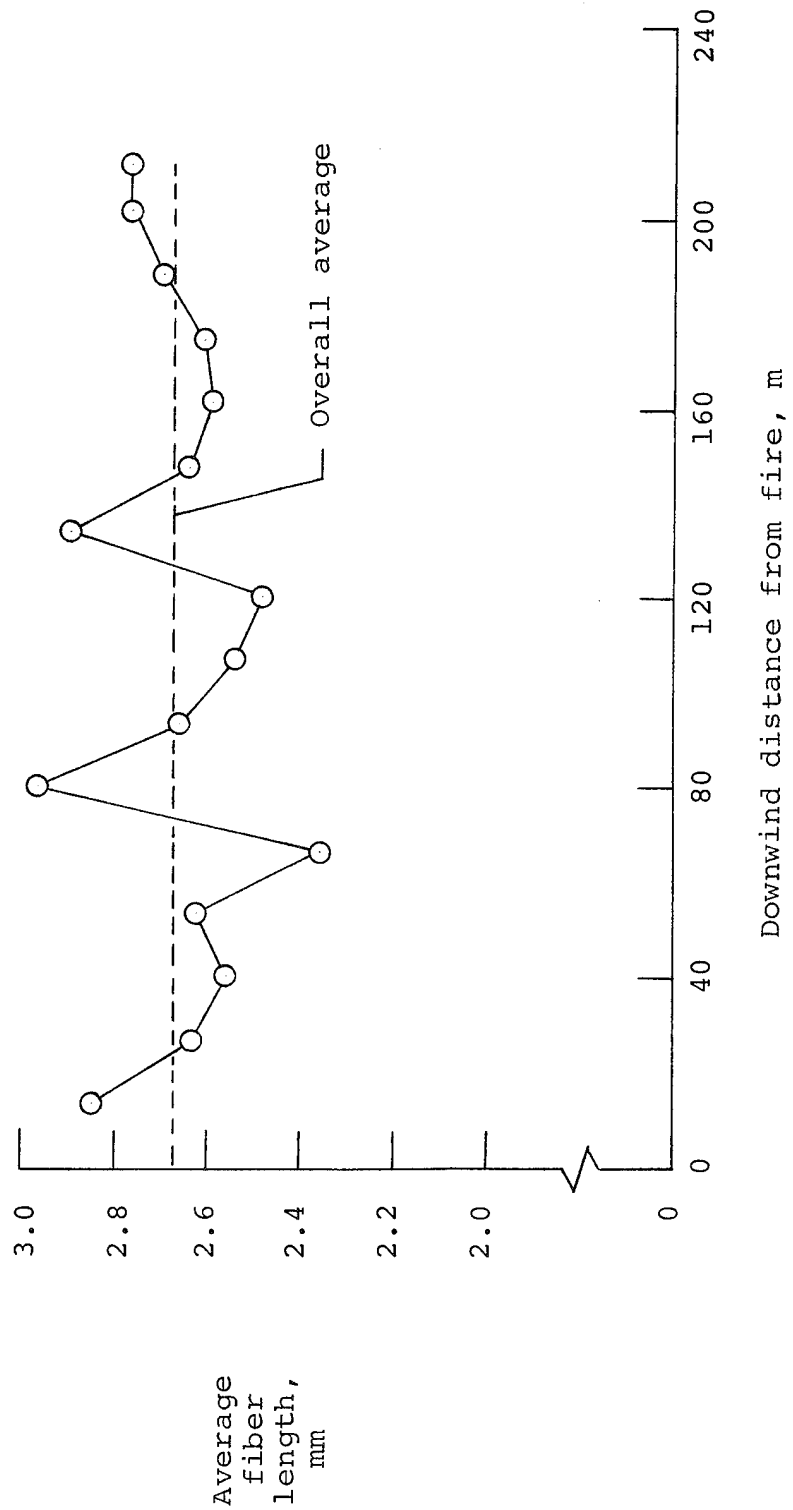

Figure 30.- Average length of fibers greater than 1 mm in length deposited at various locations on the floor of the shock tube in test 53.



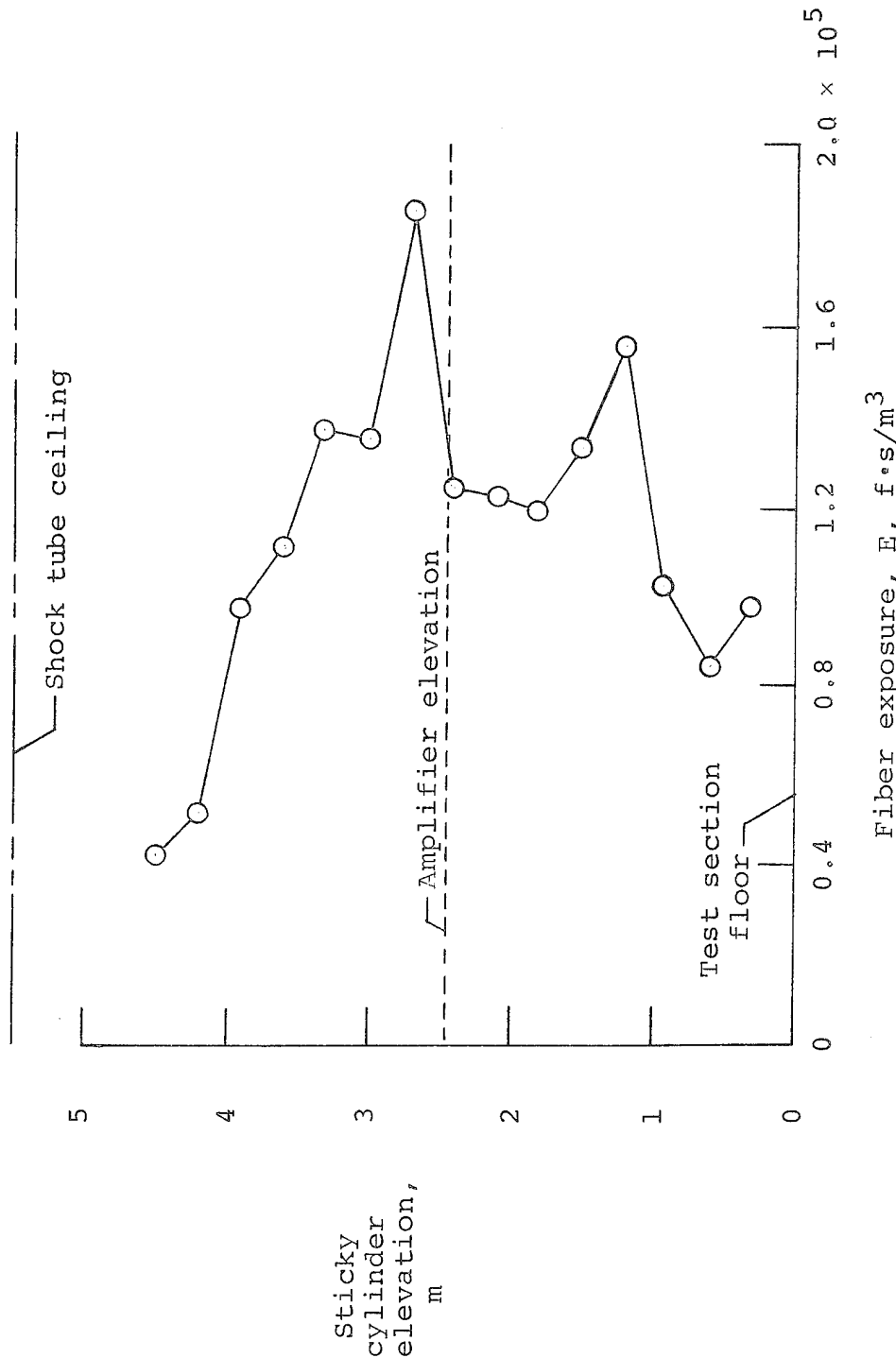

Figure 31.- Fiber exposure measured by sticky cylinders on four trees in the test section of the shock tube in test 53.

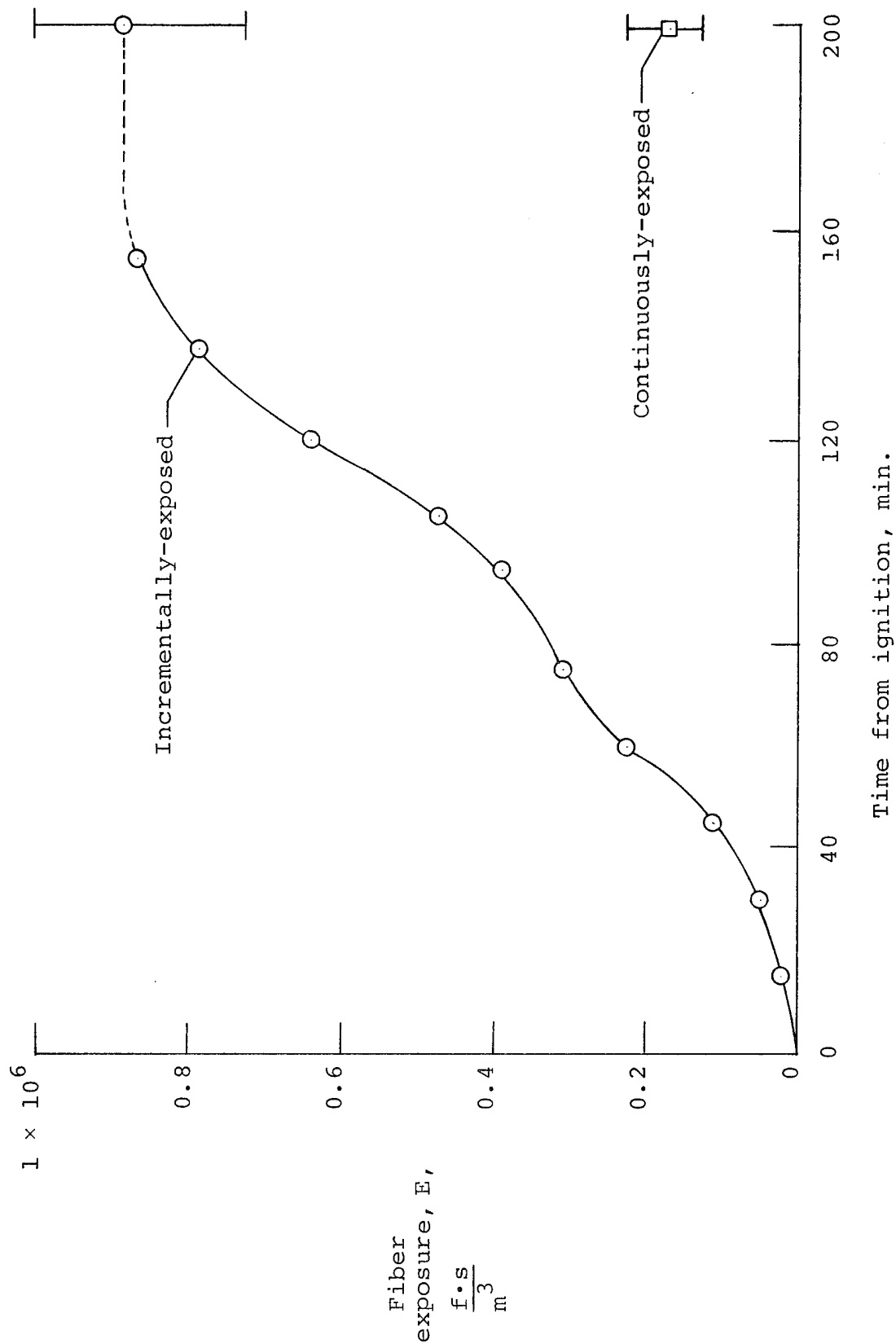

Figure 32.- Fiber exposures measured in the test section during test 53 by sticky cylinders.

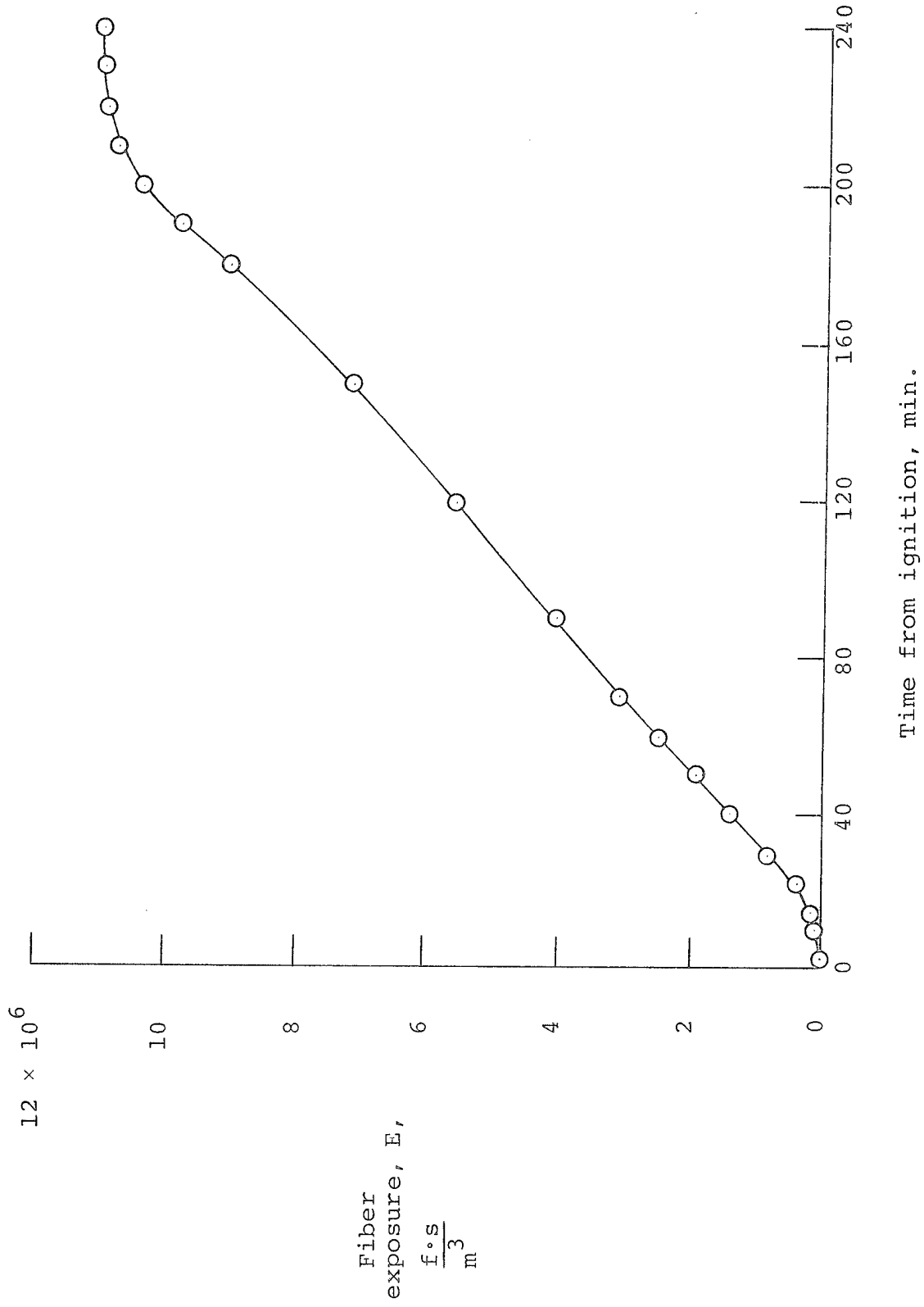

Figure 33.- Fiber exposure history measured in the test section during test 49 by the prototype model of the charged grid detector.

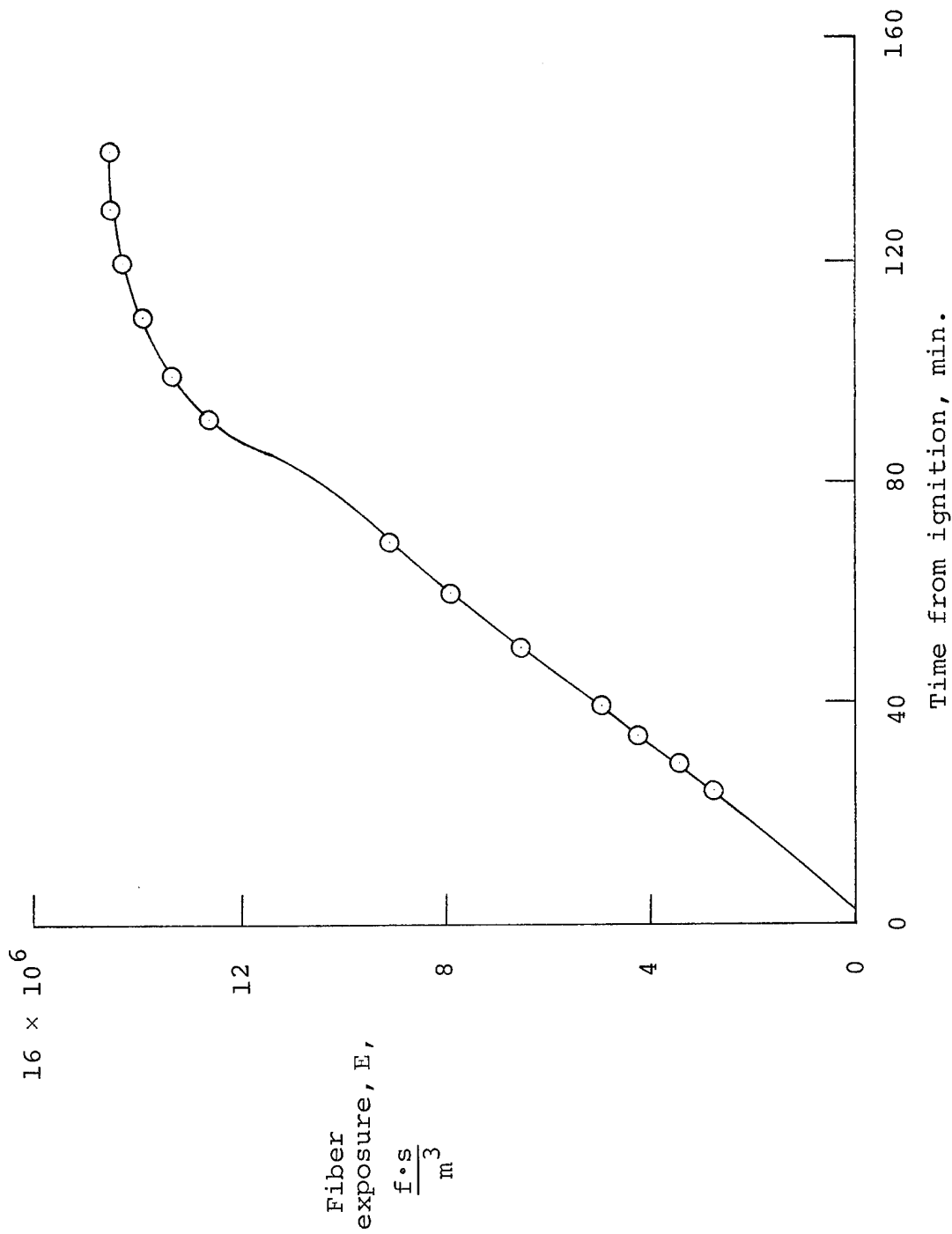

Figure 34.- Fiber exposure history measured in the test section during test 53 by the charged grid detector, model 1.

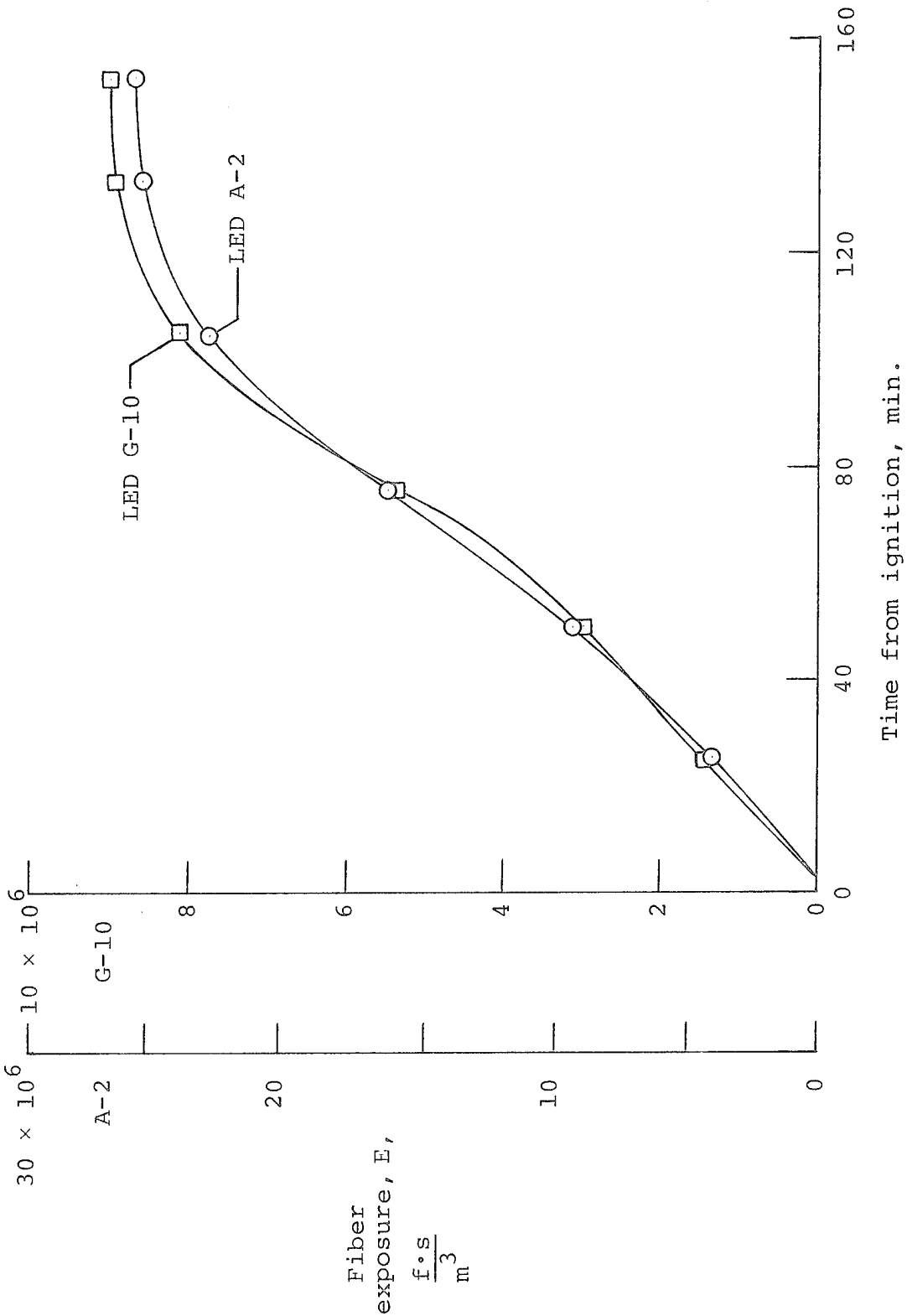

Figure 35.- Fiber exposure history measured in the test section during test 53 by two LED units.

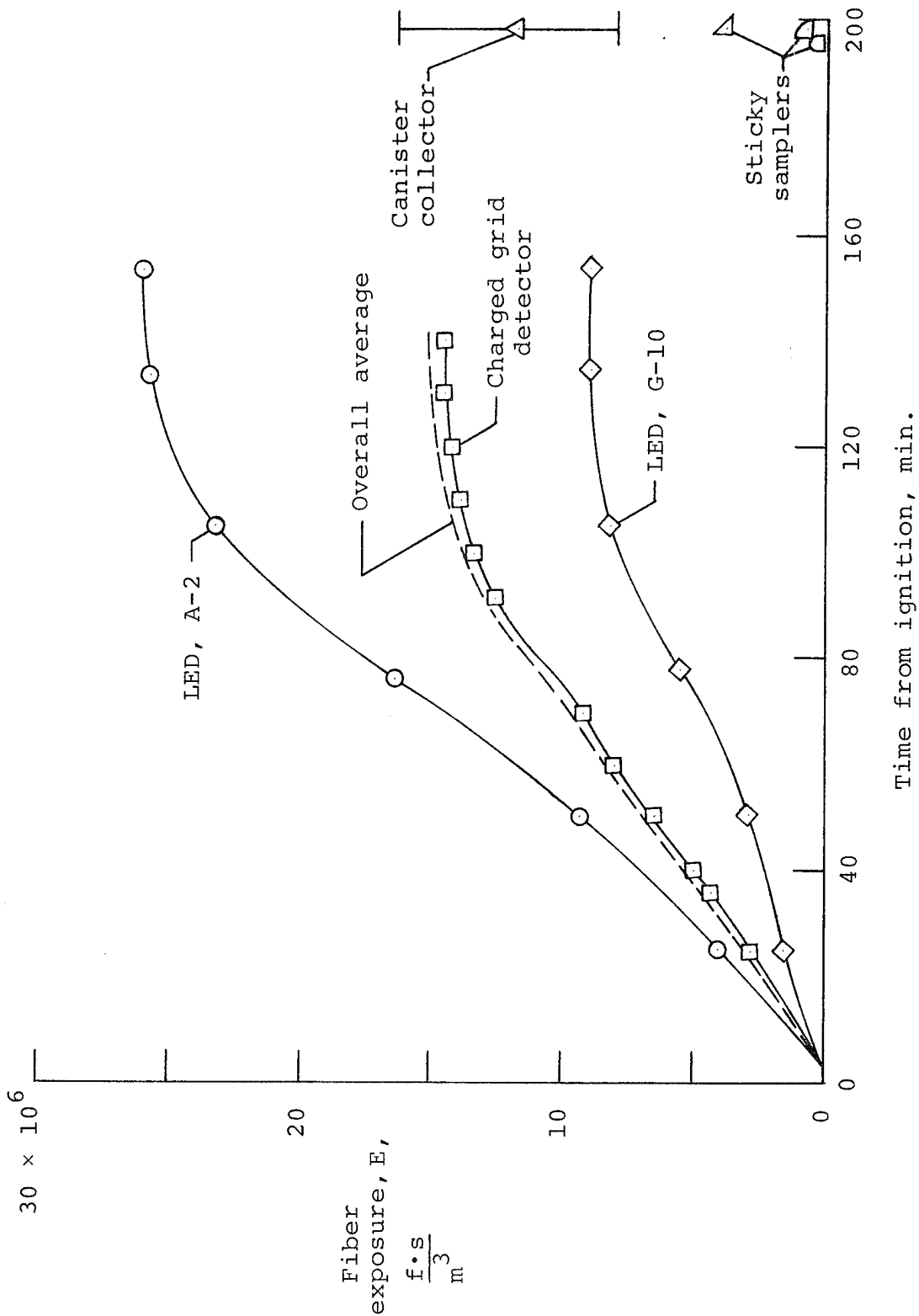

Figure 36.- Comparison of fiber exposure histories as measured by various types of instrumentation in the test section during test 53.

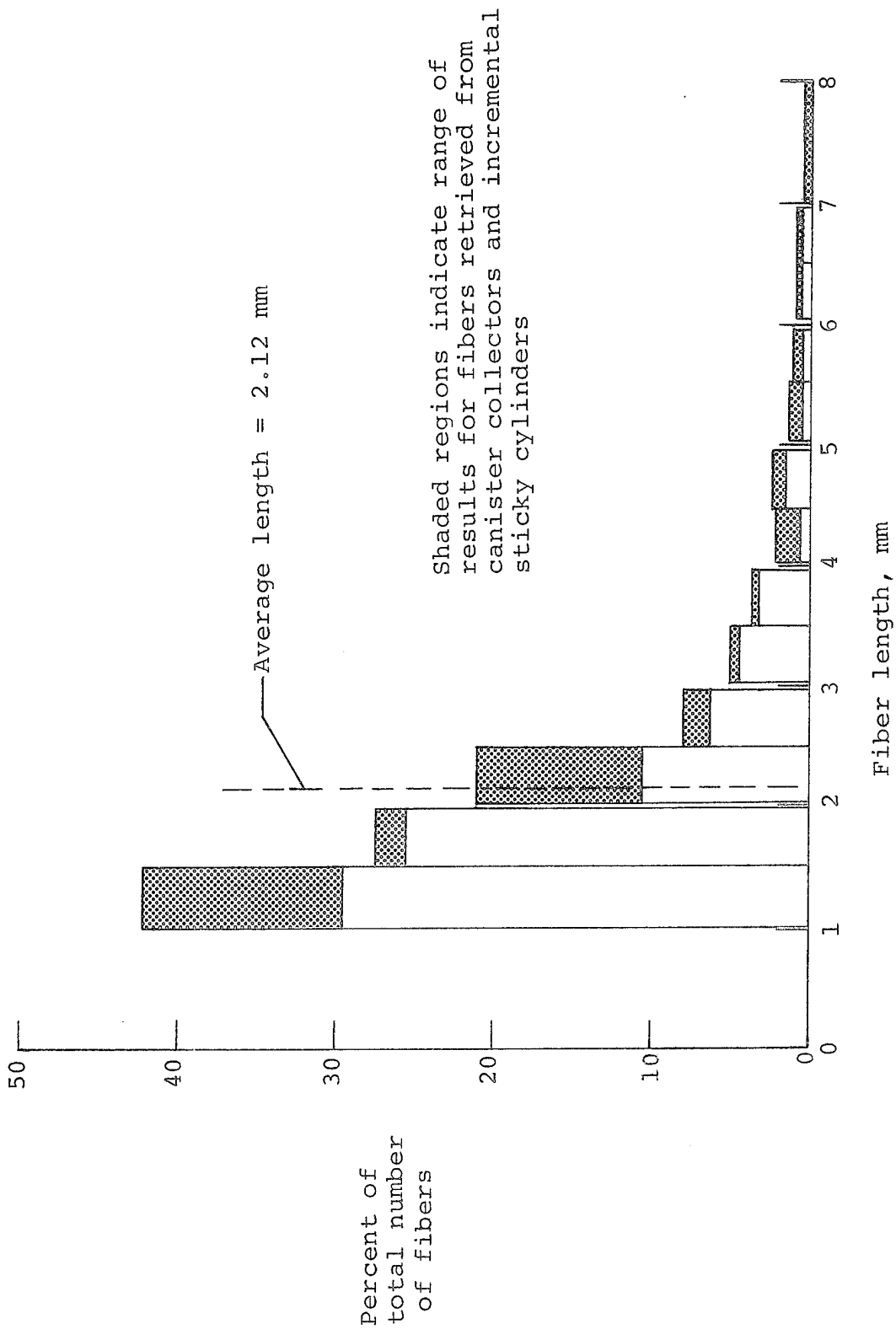

Figure 37.- Spectrum of fiber lengths for fibers greater than 1 mm in length released in test 53.

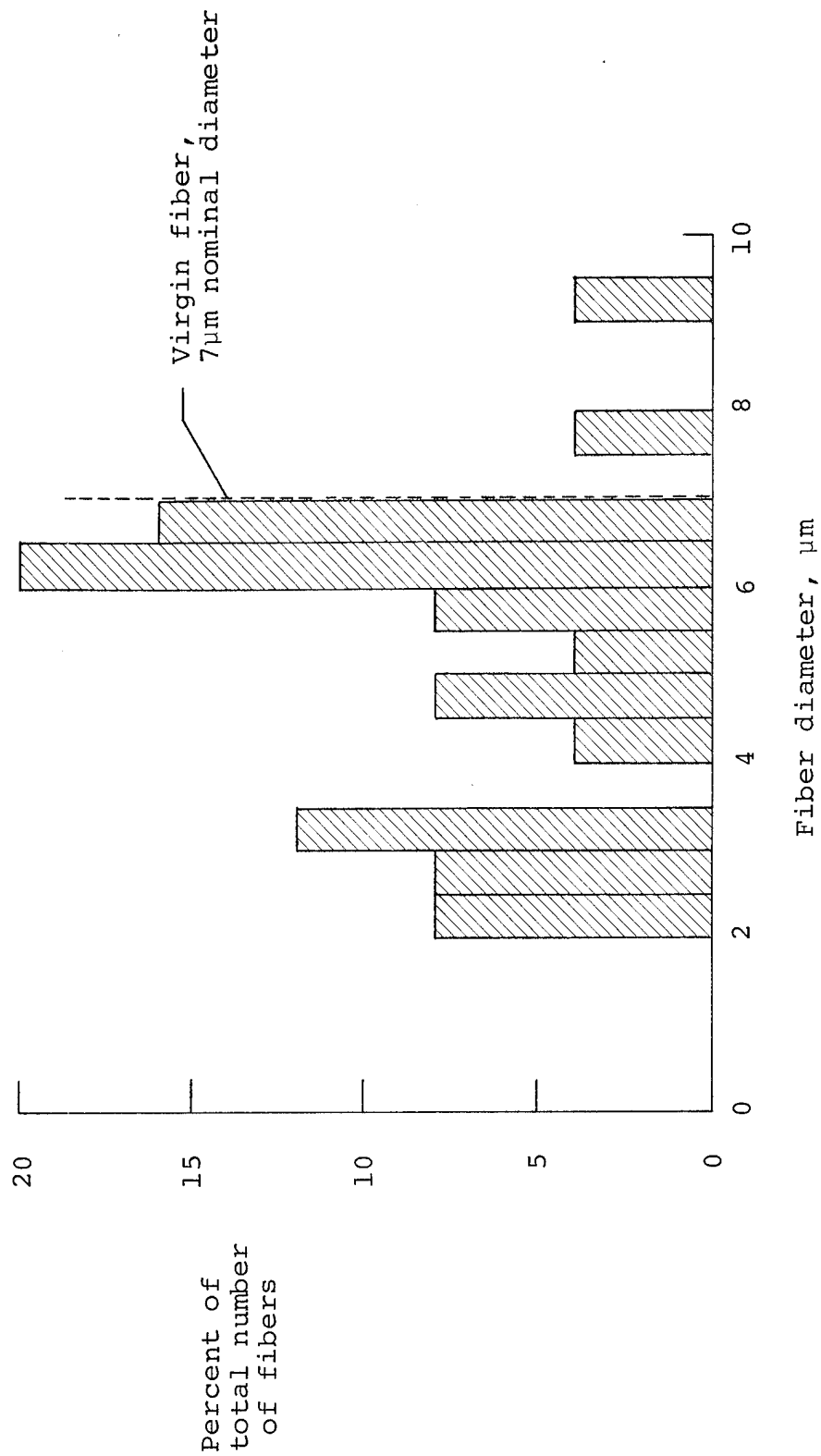

Figure 38.- Spectrum of fiber diameters for fibers greater than 1 mm in length released in test 53.



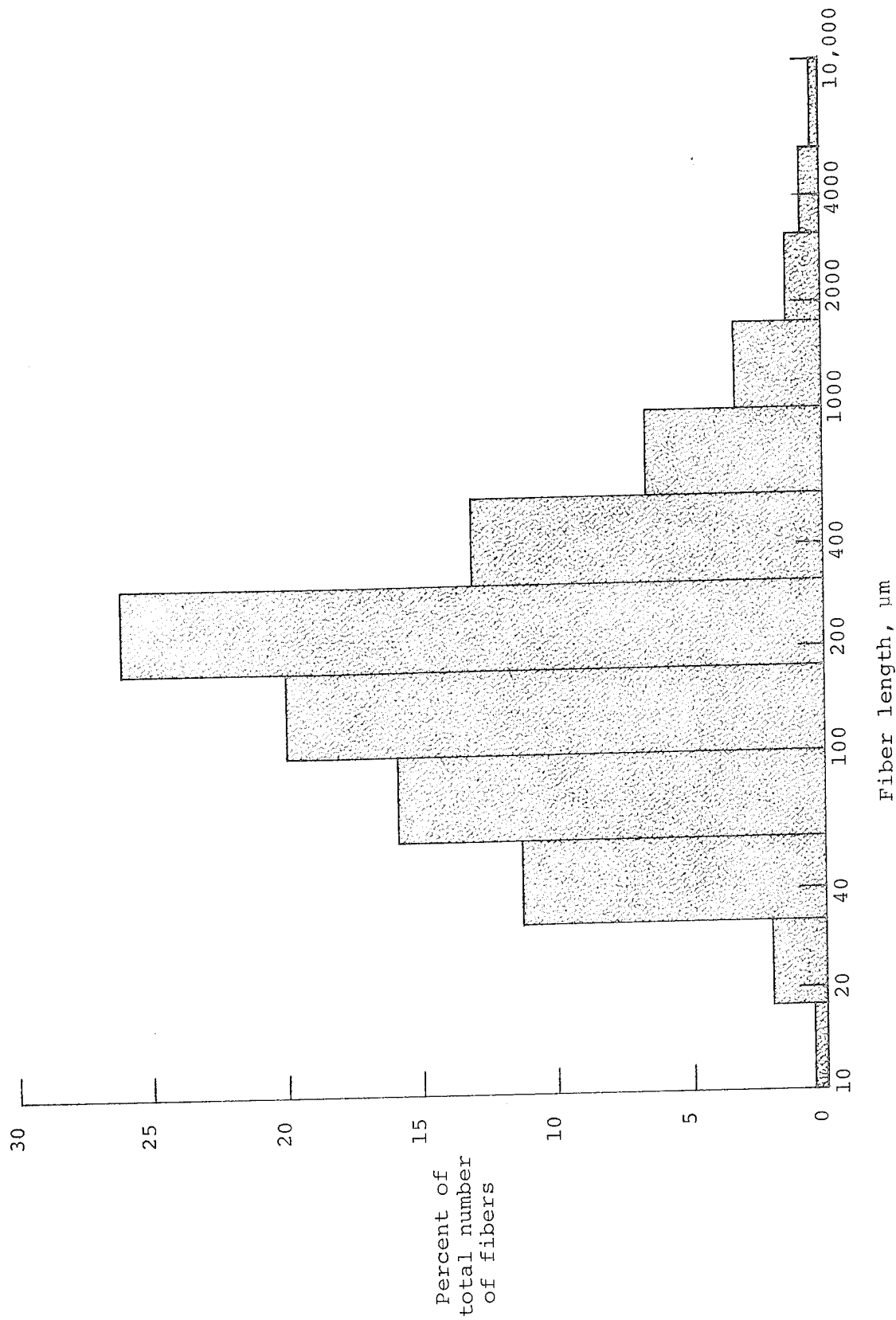

Figure 39.- Spectrum of lengths of short single carbon fibers washed out of soot on screen of canister collector.

AK 0.6 mm opening between wires

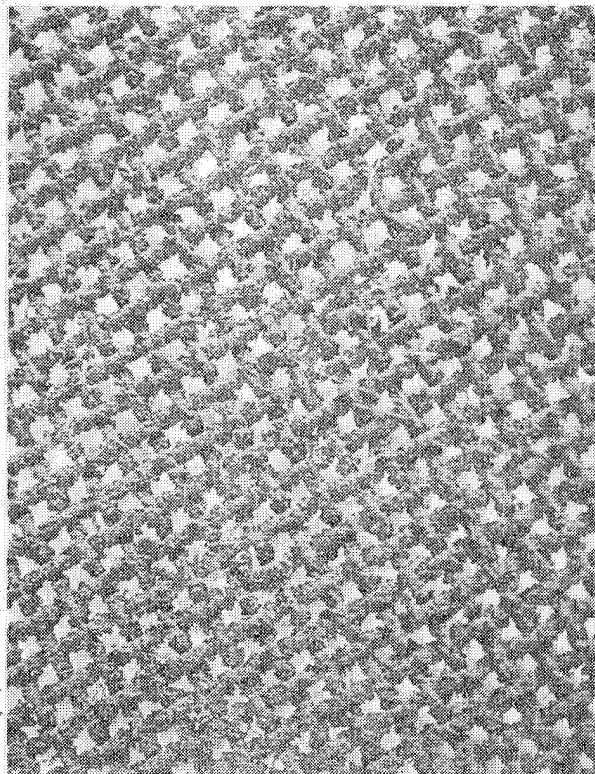

Figure 40.- Soot and carbon fiber from the smoke plume deposited on screen of canister collector 5 m downwind of aviation jet fuel fire.

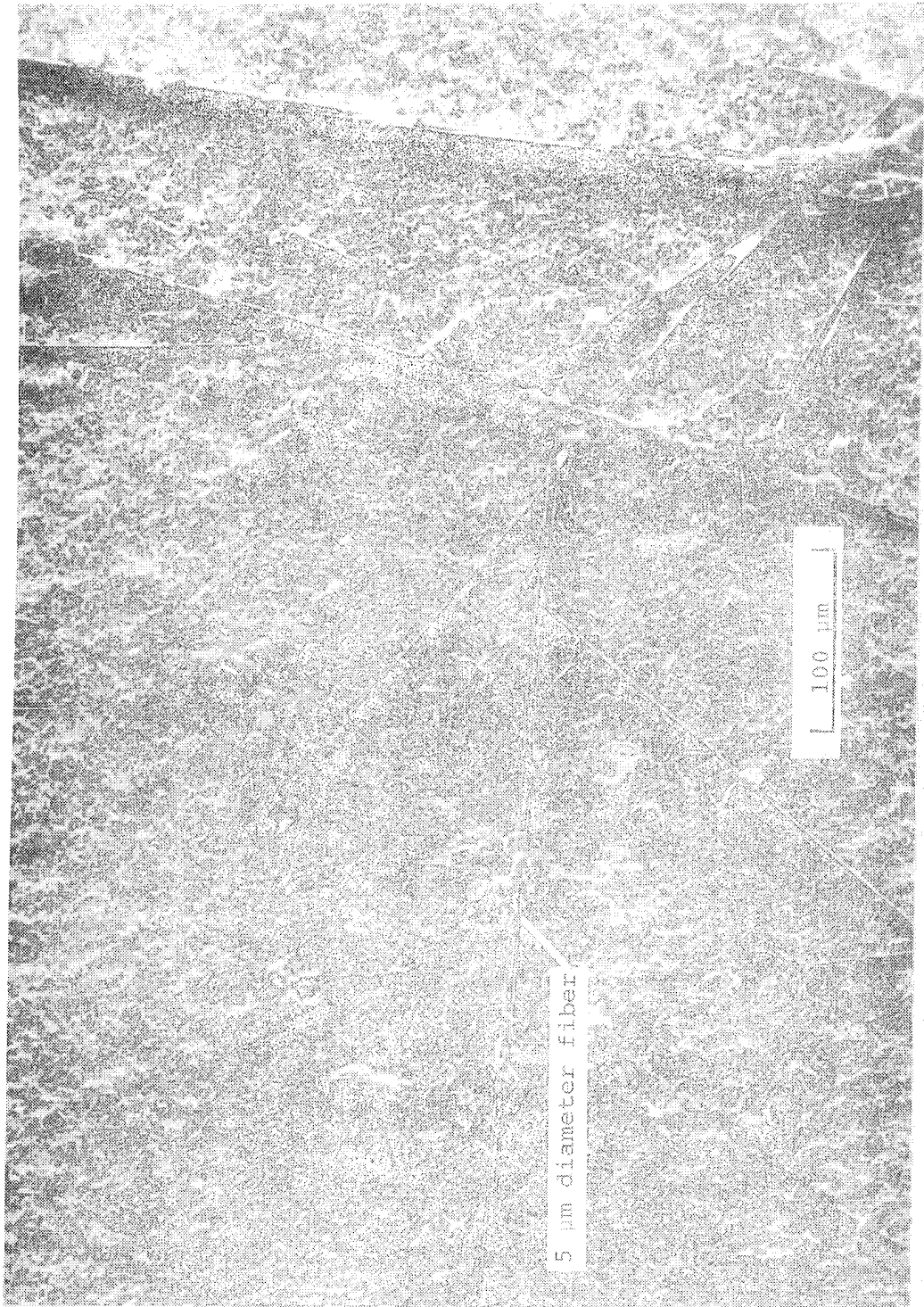
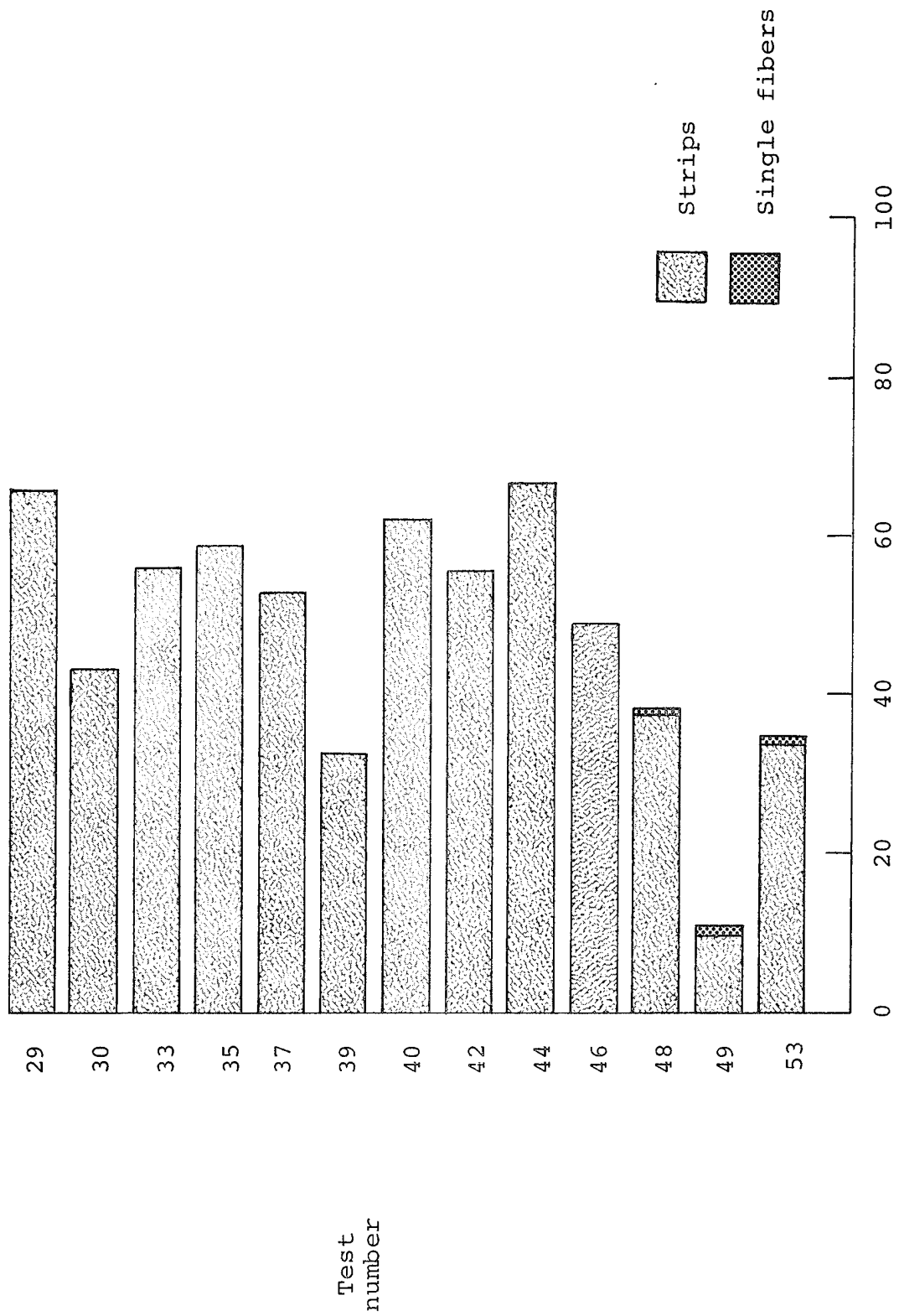

Figure 41.- Scanning electron micrograph of fire-released carbon fibers washed out of soot on screen of canister collector.



Percent of initial composite mass recovered

79 Figure 42.- Mass balance of residual composite material from aviation jet fuel fire tests in the shock tube.

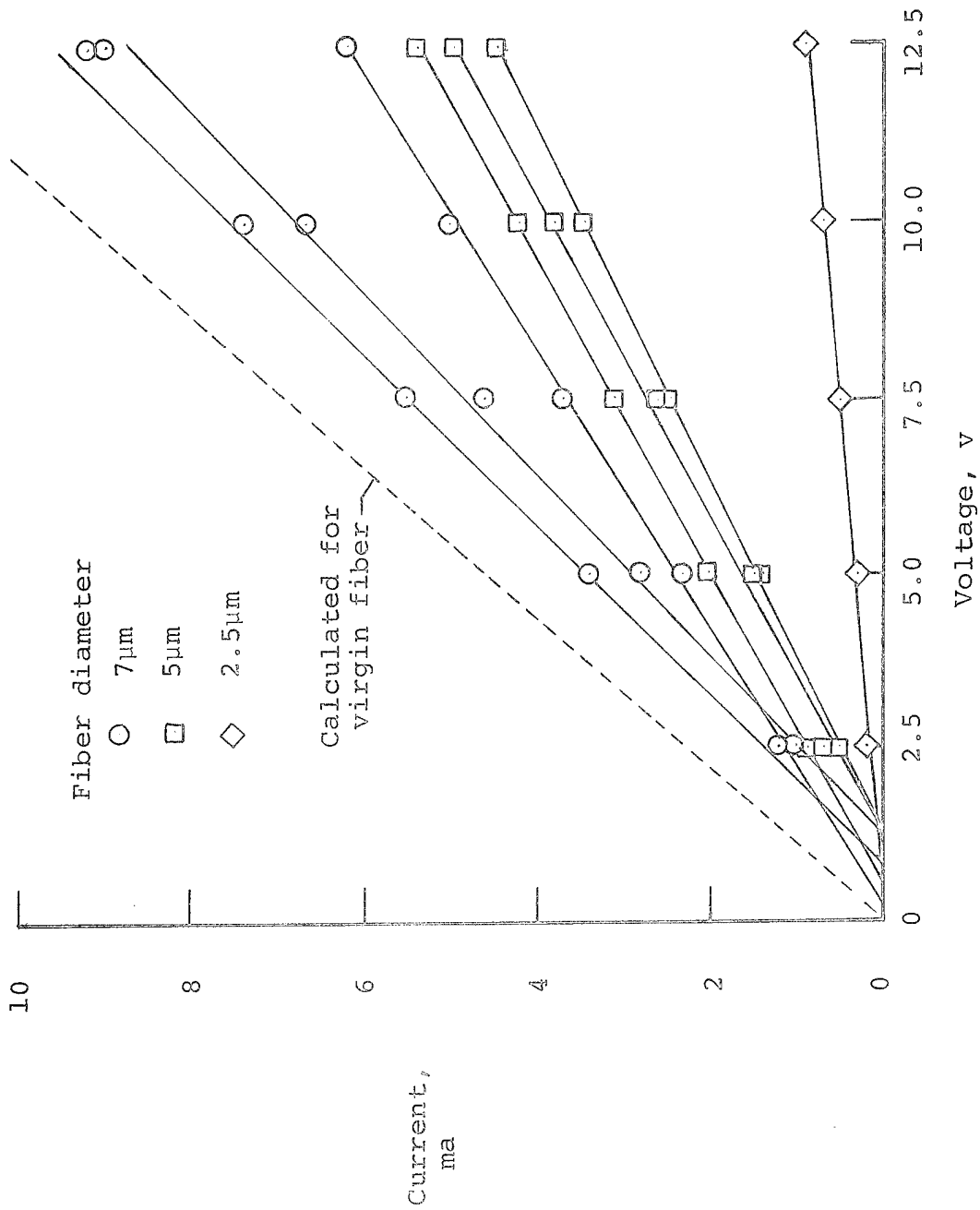

Figure 43.- Electrical current-voltage characteristics of fire-released carbon fibers from aviation jet fuel fire test 53 in Dahlgren shock tube.

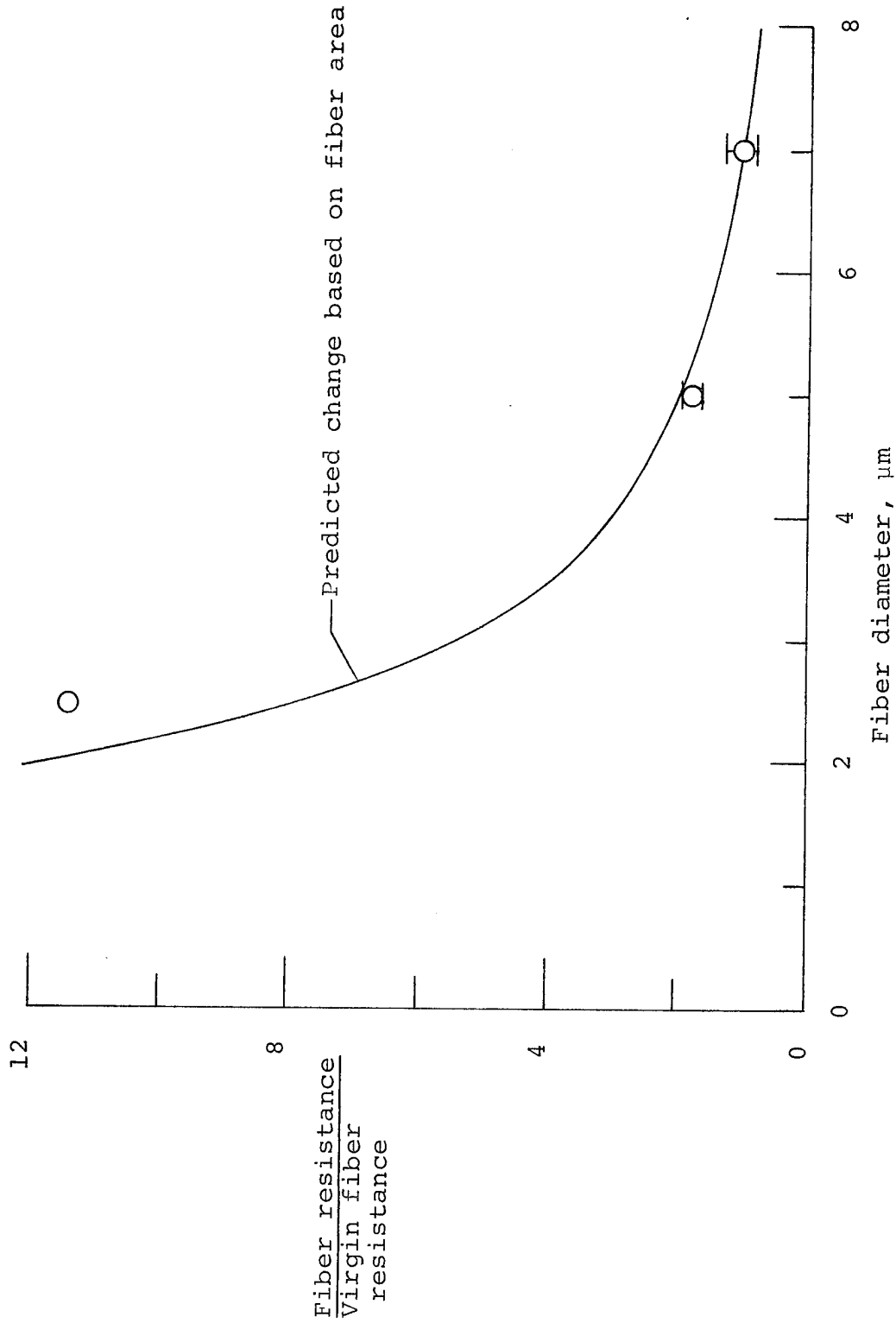
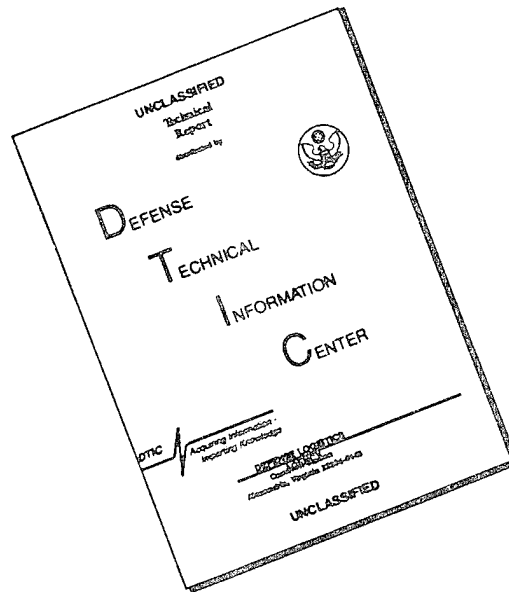

Figure 44.- Increase in electrical resistance with reduced diameter for fire-released carbon fibers from aviation jet fuel fire test 53 in Dahlgren shock tube.

1. Report No. NASA TM-80219		2. Government Accession No.		3. Recipient's Catalog No.	
4. Title and Subtitle  Electronic Equipment Vulnerability to Fire-Released Carbon Fibers				5. Report Date September 1980	
				6. Performing Organization Code	
7. Author(s) Richard A. Pride, Austin D. McHatton and Kenneth A. Musselman				8. Performing Organization Report No.	
9. Performing Organization Name and Address  NASA-Langley Research Center Hampton, VA 23665				10. Work Unit No.  534-03-23-01	
				11. Contract or Grant No.	
12. Sponsoring Agency Name and Address  National Aeronautics and Space Administration Washington, DC 20546				13. Type of Report and Period Covered  Technical Memorandum	
				14. Sponsoring Agency Code	
15. Supplementary Notes Richard A. Pride and Austin D. McHatton, NASA Langley Research Center, Hampton, Virginia Kenneth A. Musselman, U. S. Naval Surface Weapons Center, Dahlgren Lab.					
16. Abstract  The vulnerability of electronic equipment to damage by carbon fibers released from burning aircraft type structural composite materials was investigated in the shock tube facility at the U.S. Naval Surface Weapons Center, Dahlgren, Virginia. Tests were conducted on commercially available stereo power amplifiers which showed that the equipment was damaged by fire-released carbon fibers but not by the composite resin residue, soot and products of combustion of the fuel associated with burning the carbon fiber composites. The limited testing indicated that the failure rates of the equipment exposed to the fire-released fiber were consistent with predictions based on tests using virgin fibers.					
17. Key Words (Suggested by Author(s)) Fire-released carbon fibers Aviation jet fuel fires Electronic equipment vulnerability Fire testing Fiber sampling				18. Distribution Statement  Unclassified - Unlimited  Subject category 24	
19. Security Classif. (of this report) Unclassified		20. Security Classif. (of this page) Unclassified		21. No. of Pages 81	22. Price* A05



# DISCLAIMER NOTICE



THIS DOCUMENT IS BEST QUALITY AVAILABLE. THE COPY FURNISHED TO DTIC CONTAINED A SIGNIFICANT NUMBER OF PAGES WHICH DO NOT REPRODUCE LEGIBLY.