

AL/CF-TR-1995-0106

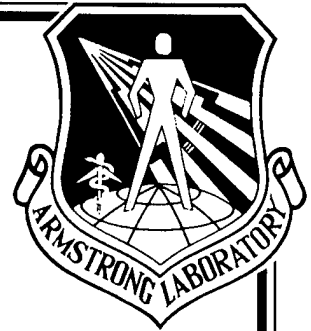

ARMSTRONG
LABORATORY

**OPERATOR CURSOR POSITIONING PERFORMANCE ON
NAVIGATIONAL UPDATE AND TARGETING TASKS
EVALUATION OF GAIN FUNCTIONS FOR THE B-2
RADAR-EMBEDDED CURSOR SYSTEM**

Jeffrey A. Doyal
Gregg E. Irvin
David P. Ramer

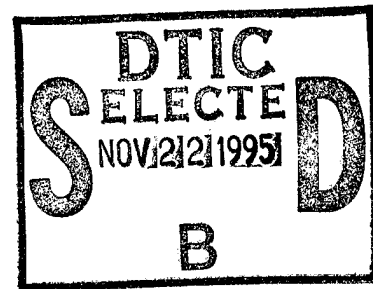

SCIENCE APPLICATIONS INTERNATIONAL
CORPORATION (SAIC)
1321 RESEARCH PARK DRIVE
DAYTON OH 45432-2817

APRIL 1995

19951121 075

INTERIM REPORT FOR THE PERIOD JUNE 1994 TO JANUARY 1995

DTIC QUALITY INSPECTED 5

Approved for public release; distribution is unlimited

**AIR FORCE MATERIEL COMMAND
WRIGHT-PATTERSON AIR FORCE BASE, OHIO 45433-6573**

NOTICES

When US Government drawings, specifications, or other data are used for any purpose other than a definitely related Government procurement operation, the Government thereby incurs no responsibility no any obligation whatsoever, and the fact that the Government may have formulated, furnished, or in any way supplied the said drawings, specifications, or other data, is not to be regarded by implication or otherwise, as in any manner licensing the holder or any other person or corporation, or conveying any rights or permission to manufacture, use, or sell any patented invention that may in any way be related thereto.

Please do not request copies of this report from the Armstrong Laboratory. Additional copies may be purchased from:

National Technical Information Service
5285 Royal Road
Springfield, Virginia 22161

Federal Government agencies and their contractors registered with the Defense Technical Information Center should direct requests for copies of this report to:

Defense Technical Information Center
Cameron Station
Alexandria, Virginia 22314

TECHNICAL REVIEW AND APPROVAL

AL/CF-TR-1995-0106

This report has been reviewed by the Office of Public Affairs (PA) and is releasable to the National Technical Information Service (NTIS). At NTIS, it will be available to the general public, including foreign nations.

The voluntary informed consent of the subjects used in this research was obtained as required by Air Force Regulation 169-3.

This technical report has been reviewed and is approved for publication.

FOR THE COMMANDER

for *William T. Withman*
KENNETH R. BOFF, Chief
Human Engineering Division
Armstrong Laboratory

Accession For	
NTIS GRA&I	<input checked="" type="checkbox"/>
DTIC TAB	<input type="checkbox"/>
Unannounced	<input type="checkbox"/>
Justification _____	
By _____	
Distribution/ _____	
Availability Codes	
Dist	Avail and/or Spec
A-1	

REPORT DOCUMENTATION PAGE

Form Approved
OMB No. 0704-0188

Public reporting burden for this collection of information is estimated to average 1 hour per response, including the time for reviewing instructions, searching existing data sources, gathering and maintaining the data needed, and completing and reviewing the collection of information. Send comments regarding this burden estimate or any other aspect of this collection of information, including suggestions for reducing this burden, to Washington Headquarters Services, Directorate for Information Operations and Reports, 1215 Jefferson Davis Highway, Suite 1204, Arlington, VA 22202-4302, and to the Office of Management and Budget, Paperwork Reduction Project (0704-0188), Washington, DC 20503.

1. AGENCY USE ONLY (Leave blank)	2. REPORT DATE April 1995	3. REPORT TYPE AND DATES COVERED Interim Report - June 1994 - January 1995	
4. TITLE AND SUBTITLE Operator Cursor Positioning Performance On Navigational Update and Targeting Tasks: Evaluation of Gain Functions For The B-2 Radar-Embedded Cursor Study		5. FUNDING NUMBERS F33615-92-D-2293 PE: 62202F PR: 7184 TA: 10 WU 45	
6. AUTHOR(S) Jeffrey A. Doyal Gregg E. Irvin David P. Ramer		7. PERFORMING ORGANIZATION NAME(S) AND ADDRESS(ES) Science Applications International Corporation 1710 Goodridge Drive McLean VA 22102	
8. PERFORMING ORGANIZATION REPORT NUMBER		9. SPONSORING / MONITORING AGENCY NAME(S) AND ADDRESS(ES) Armstrong Laboratory, Crew Systems Directorate Human Engineering Division Human Systems Center Air Force Materiel Command Wright-Patterson Air Force Base OH 45433-7022	
10. SPONSORING / MONITORING AGENCY REPORT NUMBER AL/CF-TR-1995-0106		11. SUPPLEMENTARY NOTES	
12a. DISTRIBUTION / AVAILABILITY STATEMENT Approved for public release; distribution is unlimited		12b. DISTRIBUTION CODE	
13. ABSTRACT (Maximum 200 words) Sixteen USAF crew members participated in experiments evaluating cursor slewing performance with the B-2 radar-embedded cursor system. Performance was evaluated with the current linear force/cursor velocity function and an alternative sigmoidal function expected to elicit improved performance. One experiment utilized a radar update task requiring only fine positioning movements of the cursor. The second experiment consisted of a semi-operational targeting task in which both gross and fine positioning movements of the cursor were required. In addition, the effects of ambiguity of the target pixel and variability in cursor system processing delay were examined. In both experiments, the alternative gain function elicited lower designation time and fewer overshoots than the current function. Although accuracy of the final designation was not affected by gain function in either experiment, designation error was found to be less than one pixel when the target pixel was unambiguous. Variability in the length of the cursor processing delay did not significantly impact designation error, designation time, or the number of overshoots. Subjectively, crew members unanimously preferred the alternative function for performing aimpoint designation. Based on the performance and subjective data presented here, it is recommended that the alternative gain function be considered for implementation in the aircraft.			
14. SUBJECT TERMS Radar Cursor, Position Designator, Synthetic Aperture Radar, Controls and Displays, Crew Station Design, Man-Machine Interface, Human Performance, Man-in-the-Loop Simulation, Rapid Prototyping			15. NUMBER OF PAGES 92
			16. PRICE CODE
17. SECURITY CLASSIFICATION OF REPORT UNCLASSIFIED	18. SECURITY CLASSIFICATION OF THIS PAGE UNCLASSIFIED	19. SECURITY CLASSIFICATION OF ABSTRACT UNCLASSIFIED	20. LIMITATION OF ABSTRACT UNLIMITED

This page intentionally left blank.

EXECUTIVE SUMMARY

Introduction

The primary objective of this effort was to evaluate cursor slewing and aimpoint designation performance with the B-2 radar-imbedded cursor system on both a synthetic aperture radar (SAR) navigational update task and a semi-operational GPS-aided targeting system (GATS) target designation task. This evaluation was conducted using the current linear cursor system gain function and an alternative sigmoidal or s-shaped gain function designed to elicit improved slewing and designation performance. A secondary objective of the study was to better understand how cursor positioning performance is impacted by variability in cursor system processing delay.

Crew members of the B-2 have repeatedly voiced concern regarding their inability to slew and position the radar-embedded cursor quickly and accurately when performing SAR navigational radar updates. This problem was identified through service reports and subsequently confirmed by an Armstrong Laboratory study of the B-2 radar cursor design (AL/CF-TR-1994-0020). In general, crews presently find the radar cursor difficult to precisely position. Erratic movement of the cursor during small adjustments and an inability to consistently move the cursor one pixel at a time are the most frequently expressed complaints. One contributing factor to this problem has been identified as an inadequate cursor system gain function. It is anticipated that in a GATS targeting scenario (i.e., a task requiring multiple, accurate designations within a fixed time interval), the current difficulty will be exacerbated.

Method

Sixteen United States Air Force (USAF) crew members participated in two experiments evaluating the current B-2 cursor gain function and an alternative function on the basis of cursor positioning performance. Experiment 1 evaluated performance on a SAR navigational update task, which required fine positioning of the cursor and designation of a single target on a SAR image. In addition, it examined how cursor positioning performance was influenced by ambiguity of the target pixel (i.e., whether the target pixel was cued or uncued). In doing so, the effects of cursor system gain function were isolated. Experiment 2 evaluated performance in a semi-operational GATS scenario that required both gross and fine positioning of the cursor, as well as designation of four targets on a single SAR image. In

addition to cursor system gain function, the effects of processing delay variability (i.e., whether the delay was of fixed or variable length) were examined. In both experiments, cursor positioning performance was evaluated on the basis of designation speed, designation error, and overshoots. Subjective data evaluating the two gain functions were also collected.

Results

Experiment 1

Cursor system gain function (Current vs. Alternative) was shown to significantly impact both the designation time and the number of overshoots associated with cursor positioning on the SAR navigational update task, but did not impact designation error. The Alternative gain function resulted in a higher level of cursor positioning performance, eliciting significantly shorter designation times (Alternative = 10.01 s, Current = 11.64 s) and fewer overshoots (Alternative = 1.76, Current = 2.35) than the Current gain function. This finding was supported by subjective data, in which subjects rated fine cursor positioning with the Alternative gain function as being easier than with the Current function.

Target pixel cueing was found to impact performance across all three dependent variables in Experiment 1. Designation error, designation time, and overshoots were all significantly lower when the target pixel was made unambiguous by highlighting (i.e., in the cued target pixel condition). The largest effect of target pixel cueing was on designation error, which decreased from a mean of 2.31 pixels in the uncued condition to 0.38 pixels in the cued condition.

Experiment 2

The same effects of gain function were observed on the semi-operational GATS targeting task, with the Alternative function resulting in shorter total designation time (Alternative = 11.91 s, Current = 13.15 s) and fewer total overshoots (Alternative = 2.48, Current = 3.38). Again, gain function was not shown to impact designation error, which averaged 0.37 pixels regardless of which gain function was used. When overshoots and designation time were reduced to individual gross and fine positioning components, a performance trade-off was identified between gain functions. That is, although the Alternative gain function elicited longer gross positioning times and slightly *higher* number of gross positioning overshoots than the Alternative function, it also resulted in significantly

shorter fine positioning times and a *lower* number of fine positioning overshoots. The net effect of gain function, combined across gross and fine positioning, was a 9% reduction in total designation time and a 27% reduction in total overshoots when the Alternative function was used. As in Experiment 1, subjective data supported results of the performance data. Subjects rated cursor positioning with the Alternative gain function as being easier than with the Current function.

The degree of variability in the processing delay, was not found to impact cursor positioning performance. No significant effects of processing delay variability were observed in the performance data. Subjective responses, however, indicated that subjects felt cursor positioning was easier in the fixed processing delay condition than in the variable processing delay condition.

Discussion and Conclusion

The fact that, in the cued target pixel condition, subjects were able to achieve a mean designation error of only 0.38 pixels (0.37 pixels in Experiment 2) indicates that the criterion of one pixel accuracy can be met with either cursor system gain function. The Alternative gain function, however, can be expected to elicit shorter designation times and fewer overshoots than the Current function.

While the number of overshoots helps characterize performance, a decision whether to modify the current B-2 software to implement the Alternative function should be made on the basis of speed and accuracy of the final designation. Based on results of this study, one could expect accuracy to be equally good with either gain function (0.38 pixels error). However, the Alternative gain function can be expected to elicit 14% faster designation times on the SAR navigation task and 9% faster designation times on a semi-operational GATS task requiring both gross and fine positioning. In addition, one should consider subjective responses of crew members participating in the evaluation. Every subject participating in the study preferred the Alternative gain function, rating it higher than the Current function in terms of ease of cursor positioning.

Considering the observed increases in crew member performance and acceptance associated with the Alternative cursor system gain function, it is recommended that the Alternative function described here be considered for implementation in the aircraft. Further, it is anticipated that the performance advantage of the sigmoidal gain function over a simple

linear gain function may be generalized to any task requiring both gross and fine positioning with an isometric cursor controller.

PREFACE

The research effort described in this report was performed jointly by Armstrong Laboratory and Science Applications International Corporation (SAIC) under the Systems Engineering Design and Technical Analysis (SEDATA) for Systems Integration Design and Evaluation Facility (SIDEF), SAIC Contract Number F33615-92-D-2293. The work was performed in support of the B-2 Cockpit Evaluation Facility (CEF) at the Armstrong Laboratory, Crew Systems Directorate, Human Engineering Division, Crew Systems Integration Branch (AL/CFHI), Wright-Patterson AFB, OH.

Acknowledgment is made to the following personnel who contributed many ideas and hours to the successful completion of this effort:

Members of the USAF 509th Wing, Whiteman AFB, MO.

Members of the B-2 Combined Test Force, Edwards AFB, CA.

From Armstrong Laboratory (AL/CFHI);

Lt Col Jim LaSalvia

Mr. Brad Purvis

Mr. Earl Sharp

Lt Mike Stratton

From the B-2 System Program Office (ASC/YSD) at Wright Patterson AFB;

Maj Chris Cook

Mr. Juan Diaz

Lt Jim Ebel

Capt Ron Schrupp

Capt Neil Smith

From Science Applications International Corporation (SAIC) in Dayton, OH;

Mr. Randy Frasure

Ms. Janet Irvin

Mr. Roger Overdorf

Mr. Mike Sargent

Mr. John Stengel

Mr. Tom Zawodny

TABLE OF CONTENTS

SECTION I INTRODUCTION.....	1
Objective	1
Background	2
Existing B-2 Cursor System	6
SECTION II DEVELOPMENT OF ALTERNATIVE GAIN FUNCTION FOR USE IN EXPERIMENTATION.....	9
SECTION III APPROACH	11
Target Pixel Cueing.....	11
Cursor Processing Delay Variability	12
Experimental Design	12
SECTION IV EXPERIMENT 1 SAR NAVIGATIONAL UPDATE TASK.....	16
Method.....	16
Subjects	16
Apparatus	16
Stimuli.....	18
Procedure	20
Results	23
Performance Data.....	23
Designation Error.....	23
Designation Time.....	25
Overshoots.....	25
Subjective Evaluations.....	28
Discussion.....	32
Gain Function	32
Target Pixel Cueing	34
SECTION V EXPERIMENT 2 SEMI-OPERATIONAL GATS TARGETING TASK	37
Method.....	37
Subjects and Apparatus	37
Stimuli.....	37
Procedure	38
Results	39
Designation Error.....	39
Designation Time.....	39
Overshoots.....	42
Subjective Evaluations.....	44
Overall Subjective Evaluations	45
Discussion.....	48
Gain Function	48
Processing Delay Variability.....	49
Reduction of Processing Delay	50
SECTION VI CONCLUSION AND RECOMMENDATIONS	52
Conclusion	52
Recommendations.....	53

TABLE OF CONTENTS

BIBLIOGRAPHY	55
LIST OF SYMBOLS, ABBREVIATIONS, AND ACRONYMS	56
APPENDIX A DEVELOPMENT OF ALTERNATIVE GAIN FUNCTION	57
APPENDIX B B-2 RADAR CURSOR MECHANIZATION STUDY SUBJECT INSTRUCTIONS	64
APPENDIX C B-2 RADAR CURSOR MECHANIZATION STUDY QUESTIONNAIRE.....	68
APPENDIX D RESPONSES TO OPEN-ENDED QUESTION ON SUBJECT QUESTIONNAIRE	76

LIST OF FIGURES

FIGURE	PAGE
1-1. Original (a) and Alternative (b) B-2 synthetic aperture radar cursors.....	3
1-2. Six gain functions evaluated for the F-14D cursor control system (from Rauch, 1988).....	4
1-3. Current B-2 cursor system gain function.....	6
1-4. B-2 radar cursor system data processing path.....	8
2-1. Alternative B-2 radar-embedded cursor system gain function.....	9
2-2. Current and Alternative B-2 radar-embedded cursor system gain functions .	10
4-1. Experimentation hardware configuration.....	17
4-2. Example of SAR imagery used in uncued target pixel condition.....	19
4-3. Example of SAR imagery used in cued target pixel condition.....	20
4-4. Example of RFP card used in uncued target pixel condition.....	21
4-5. Mean effects of gain function on designation error for each level of target pixel cueing.....	24
4-6. Mean effects of gain function (a) and target pixel cueing (b) on designation error.....	24
4-7. Mean effects of gain function on designation time for each level of target pixel cueing.....	26
4-8. Mean effects of gain function (a) and target pixel cueing (b) on designation time.....	26
4-9. Mean effects of gain function on overshoots for each level of target pixel cueing.....	27
4-10. Mean effects of gain function (a) and target pixel cueing (b) on overshoots.....	27
5-1. SAR imagery with four highlighted target pixels.....	37
5-2. Mean effects of gain function on designation error for each level of delay variability.....	40
5-3. Mean effects of gain function (a) and delay variability (b) on designation error.....	40
5-4. Mean effects of gain function on designation time (per target) for each level of delay variability.....	41
5-5. Mean effects of gain function (a) and delay variability (b) on designation time.....	41
5-6. Mean effects of gain function on overshoots for each level of delay variability.....	43
5-7. Mean effects of gain function (a) and delay variability (b) on overshoots ...	43
5-8. Linear regression fit to data presented in Basile (1990).....	51

LIST OF TABLES

TABLE	PAGE
1-1. B-2 Radar Cursor System Data Transport Delay.....	8
3-1. Independent and Dependent Variables in Experiments 1 and 2.....	15
4-1. Subject Background and Experience	16
4-2. Magnitude and Distribution of Simulated Variable Processing Delay.....	18
4-3. Subjective Evaluation of Simulation/Experimentation Fidelity.....	28
4-4. Subjective Evaluations of Performance on the Uncued Target Pixel Task...	30
4-5. Subjective Evaluations of the Effect of Gain Function on Fine Cursor Positioning	31
5-1. Subjective Evaluations of Effect of Gain Functions on Gross Cursor Positioning.....	45
5-2. Subjective Evaluations of Effect of Delay Variability	46
5-3. Overall Subjective Evaluations of Gain Functions	47
5-4. Extrapolation from Basile (1990) to Current Data.....	51
A-1. Look-up Table Defining Alternative Gain Function.....	63

This page intentionally left blank.

SECTION I

Introduction

Crew members in a number of U.S. military aircraft often perform tasks requiring precise placement of a radar-embedded cursor on a video display in the cockpit. Activities requiring this cursor placement task include performing navigational radar updates and target designation. Frequently, these tasks are conducted using an isometric, hand-operated cursor controller. With a control mechanism of this type, cursor movement is obtained by applying lateral force with the thumb or forefinger against a concave, stationary button.

Such a cursor control mechanism is currently used in the B-2 for the purpose of performing synthetic aperture radar (SAR) updates and will, in the future, be used for global positioning system (GPS)-aided targeting system (GATS) purposes. Crew members representing the United States Air Force (USAF)/Northrop Combined Test Force (CTF) and Air Combat Command (ACC) have repeatedly voiced dissatisfaction with their ability to quickly and accurately control the radar-embedded cursor. In April 1993, this problem was briefed at the Watch Item Review Board at Edwards AFB and upgraded to service report status (Material Improvement Project #20198, *Radar Cursor Controller Slew*). The primary problem that crew members have related is an inability to perform fine positioning with the current cursor control system, often being unable to move a single pixel at a time, and subsequently overshooting their intended designation point. This difficulty currently results in operator frustration, and can impact operational effectiveness under time/accuracy-critical conditions.

Objective

The main objective of this research effort was to develop and evaluate an alternative cursor controller gain function that will improve cursor positioning speed and accuracy on both navigational update and targeting tasks. In addition, this research was designed to investigate effects of extraneous factors impacting designation speed and accuracy including target pixel ambiguity and processing delay variability. Although cursor positioning can be performed by either the pilot or mission commander (MC) in the B-2, this study addressed performance with only the MC cursor control panel.

Background

A number of parameters can impact the speed and accuracy of cursor placement on fixed target objects. These include target size and shape, cursor size and shape, the type of control mechanism (i.e., joystick, trackmarble, isometric controller, etc.), the gain function driving the control mechanism, and the amount and variability of processing delay in the cursor system. Each of these variables can be manipulated in an effort to improve performance on a given task. However, given limited resources and practical considerations involved with modifying a complex fielded system, certain parameters lend themselves more easily to manipulation than others. Updates to software code, for example, can usually be accomplished for a fraction of the cost of a hardware upgrade. With regard to the current B-2 radar cursor system, software parameters including 1) cursor design, 2) gain function, and 3) processing delay variability were selected for evaluation in an attempt to improve cursor slewing and designation performance.

Cursor Design: In addressing cursor positioning performance, the first area to be investigated was the physical structure or appearance of the B-2 radar-embedded cursor. In 1993, a study was conducted in an effort to improve designation speed and accuracy by modifying the size and shape of the cursor itself (Irvin, Doyal, Sharp, LaSalvia, 1993). This study evaluated two alternative cursor designs against the existing design on the basis of operator performance on a SAR navigational update task. It was found that the original design, shown in Figure 1-1a, caused targets to be obscured by the cursor. This obscuration caused operators to initially move the cursor *away* from the target area before returning to the target and designating. In addition, the center opening in the original cursor was found to be too wide, causing confusion as to which pixel lay in the true center of the cursor. An alternative cursor with narrower leg segments and a smaller center opening was developed and was shown to reduce these difficulties. See Figure 1-1b.

The alternative cursor elicited a significant improvement in designation accuracy, and has recently been approved for implementation in the aircraft. Although designation accuracy improved significantly with the alternative cursor, crew members who participated as subjects were still unable to achieve designation accuracy within a stated performance criterion of one pixel. Although some degree of the remaining error may be attributed to

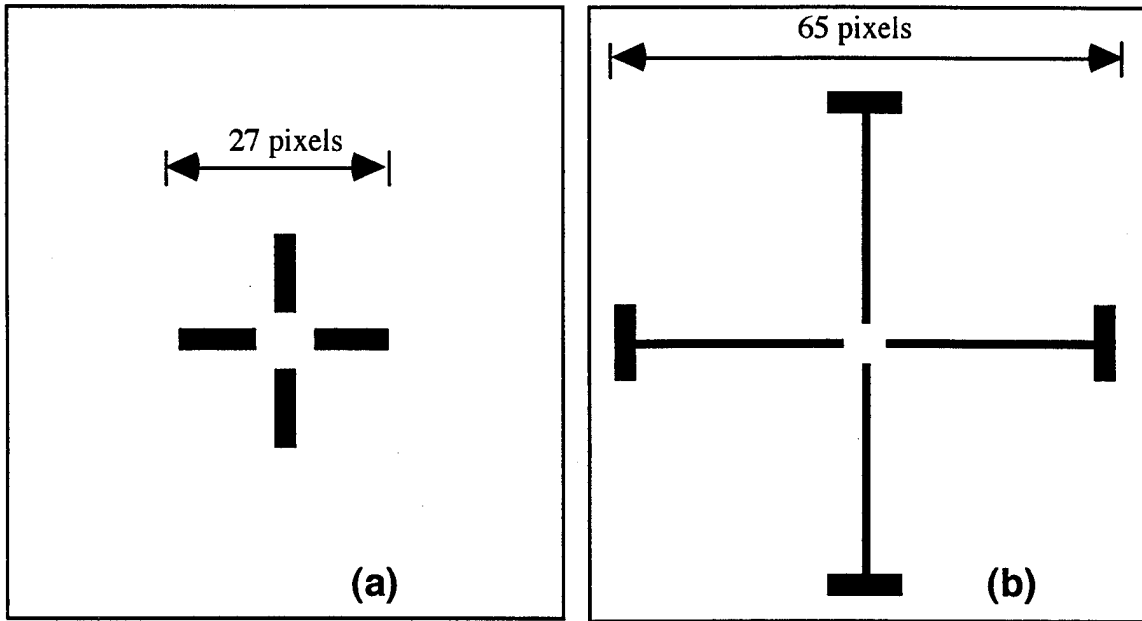

Figure 1-1. Original (a) and Alternative (b) B-2 synthetic aperture radar cursors. The smaller center opening and the longer, narrower legs of the Alternative cursor were shown to reduce obscuration of the target area and to improve designation accuracy.

image interpretation error (discussed in Section III), subjects often remarked that the control mechanism was inadequate. Subjective comments obtained in post-experiment interviews suggested that the remaining error in slewing was unrelated to cursor design, but rather was due to the operators' inability to control the cursor when performing fine positioning. Performance data validated these assertions, revealing that subjects repeatedly overshoot the target before designating. Both researchers and subjects attributed this problem, in part, to 1) a sub-optimal gain function driving the cursor, and 2) a significant processing delay in the cursor system. These two issues, which are addressed in the current study, are discussed below.

Cursor System Gain: The gain function in a cursor control system represents the relationship between input and output magnitudes. With regard to an isometric cursor control like that used in the B-2, the gain function refers to the velocity of cursor movement on the screen associated with a given lateral force input on the control button. A number of studies examining optimal cursor system gain have been conducted in the past (Gibbs, 1962; Hammerton, 1962; Hammerton & Tickner, 1966). However, these studies have examined gain functions for use with a joystick, which utilizes physical displacement of a control mechanism in order to achieve a corresponding cursor displacement on a display screen.

Such research may not be directly applicable to an isometric cursor controller, which relies on isometric force rather than physical displacement.

The specific issue of determining an optimal gain function for an isometrically-controlled cursor system in combat aircraft was addressed in a study of the F-14D system (Rauch, 1988). Similar to the B-2 system, the F-14D system uses a breakout force of 0.5 lb and reaches a maximum cursor velocity at 3.0 lb of input force. The Rauch study examined cursor slewing and designation performance for gain functions that consisted of two distinct linear segments. For forces below 1.75 lb, a gain with a lower slope was implemented to facilitate fine positioning. Higher slopes were used at forces greater than 1.75 lb to facilitate gross movement of the cursor. The slope associated with low forces was identical across Functions 1, 2 and 3 (Group A functions). Similarly, the slope at the low end of Functions 4, 5 and 6 (Group B functions) was constant. The slope at the high end varied across all functions. Figure 1-2 shows the six gain functions evaluated in the Rauch (1988) study.

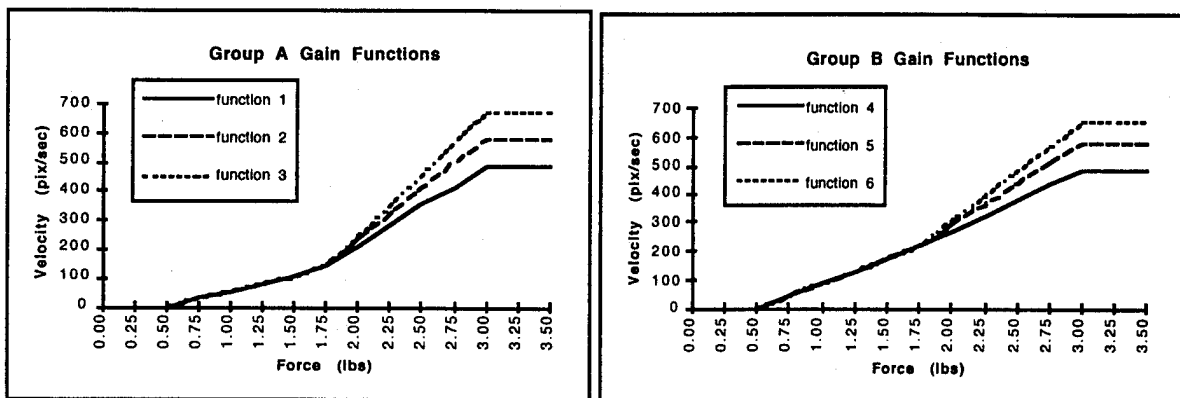

Figure 1-2. Six gain functions evaluated for the F-14D cursor control system (from Rauch, 1988). Performance was shown to be best with Gain Function 1, the lowest Group-A gain function.

The Rauch study found that functions with the higher fine-motor-control gain (i.e., the Group B functions) elicited higher designation times and lower designation accuracy than did those with the lower fine-motor-control gain (Group A functions). In addition, Gain Function 1 (the lowest overall gain function) elicited the best designation speed and accuracy performance. Comments from subjects participating in the Rauch study confirmed this finding, indicating that they preferred the lower fine-motor-control gain functions. The lowest gain function reached a velocity of 146 pix/s at a force of 1.75 lb and a maximum

velocity of 486 pix/s at a force of 3.0 lb.¹ As Rauch (1988) concludes, it is possible that better designation speed and accuracy could be obtained if even lower fine-motor-control gains were used.

Processing Delay: Another parameter that can impact performance is the processing delay or “lag” in the system. A processing delay such as that exhibited in the B-2 radar cursor system is not uncommon in complex control systems. In any system, such a lag can significantly impact a user’s ability to perform a manual control task. When there is no immediate feedback reflecting the result of a control movement, the user must anticipate or guess the amount of input required to achieve the desired result.

It is well established that as processing delay increases, time to perform a cursor control task increases (Gibbs, 1962; Basile, 1990). Investigating the impact of processing delay on ability to position a cursor using a trackmarble, Basile (1990) examined performance under delay conditions ranging from 75 ms to 400 ms. Basile showed that as processing delay was increased from 75 ms to 400 ms, the mean time to perform a cursor positioning task increased from 3.462 s to 5.864 s, a 69% increase. Additionally, after factoring out the time between trial onset and the first movement as well as the time between the final movement and designation, actual cursor movement time was found to increase from 2.157 s with a 75 ms delay to 4.223 s with a 400 ms delay, a 96% increase.

To further characterize the effects of processing delay, Basile (1990) also collected subjective data from his subjects. This data revealed that 50% of subjects could “perceive” a cursor processing delay of 120 ms. Fifty percent of his subjects found the delay to be “annoying” at lengths of 200 ms or more. Once processing delays reached 270 ms, subjects felt that the delay was “unreliable” and unacceptably long.

The Basile (1990) study clearly demonstrated how detrimental a processing delay can be to an operator’s ability to perform a cursor positioning task. This effect was seen even though the delays in the study were constant or “fixed.” That is, they did not contain the variability or irregularity caused by the fluctuation in processing activity that is inherent to many control systems. In theory, such variability in delay will further exacerbate the performance deficiencies caused by a fixed processing delay due to subjects’ inability to consistently predict the output (i.e., cursor movement) associated with a given control input.

¹ Cursor velocities described in pixels/sec were translated from radians/sec reported by Rauch using reported viewing distance and monitor resolution.

Existing B-2 Cursor System

The current B-2 cursor system can be characterized in terms of the three components discussed above: cursor design, processing delay, and system gain function. The current cursor design, shown in Figure 1-1a, will be replaced with a new design (Figure 1-1b) with the next B-2 software upgrade. A full description of the new cursor design is presented in Irvin et al, 1993. The following is a description of the current gain function and processing delay associated with the B-2 radar-embedded cursor system.

Cursor System Gain Function: The gain function currently driving the B-2 radar-embedded cursor system consists of a simple linear relationship between input force and cursor velocity. This function has a deadband of approximately 0.50 lb, such that any force of less than 0.50 lb exerted on the controller results in no movement of the cursor. For forces between 0.50 and 3.00 lb, cursor velocity increases linearly from 0 to 191 pix/s. The cursor continues at a rate of 191 pix/sec for input forces greater than 3.00 lb. This function is illustrated in Figure 1-3.

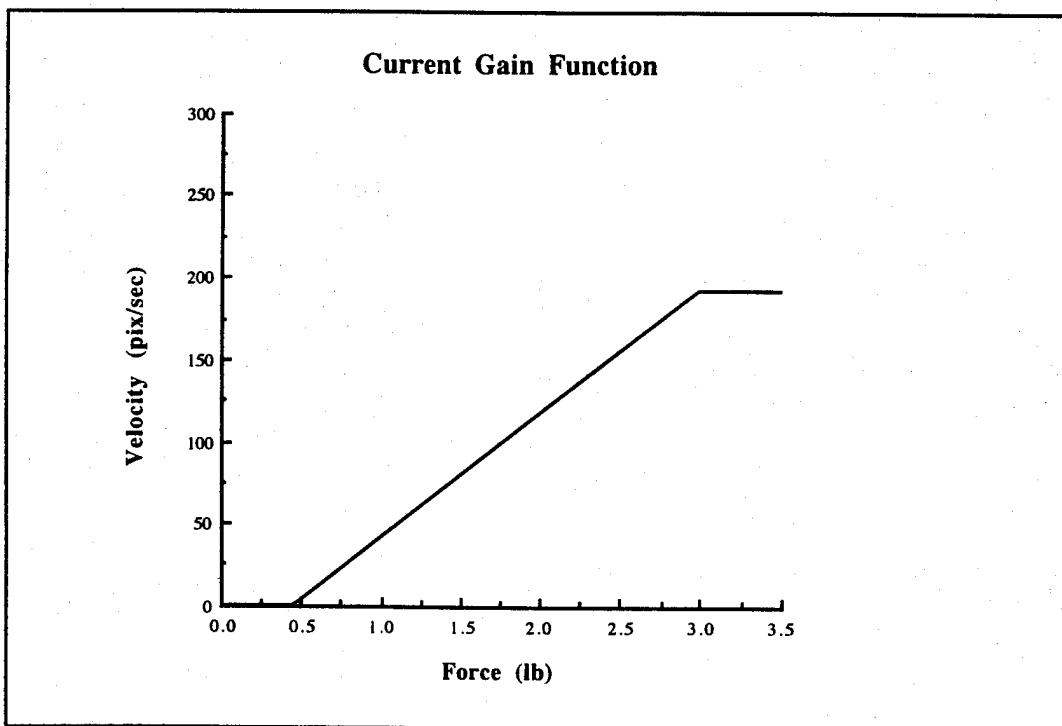

Figure 1-3. Current B-2 cursor system gain function.

Processing Delay: One characteristic of the B-2 radar cursor system is that cursor positioning information is processed through the overall radar system, resulting in a significant amount of cursor processing delay. As depicted in Figure 1-4, once a cursor input is made to the cursor control panel (CCP), signal data travels from the CCP to the Display Processing Unit (DPU). From the DPU, it is sent to the Flight Management Control Processor (FMCP), which subsequently relays this data to the radar. The radar then returns a video signal, including the updated cursor position, to the DPU for presentation on the video screen. Within each subsystem in this pathway, there is an associated processing delay that increases cumulatively with each successive component. This delay is of a fixed length in certain components and can vary in others. In addition, a transport delay may occur if a multiplex (MUX) delay causes the FMCP to transmit the radar MUX message during the arrival of the DPU message. Table 1-1 lists the minimum and maximum delay caused at each point in the processing pathway.² The variability in processing and transfer times can result in an overall system delay time as short as 179 ms or as long as 407 ms depending upon the immediate states of each component. Although the mean processing delay has not been systematically quantified, an estimate of this mean was developed through discussions between representatives of the B-2 SPO and AL. It was estimated that the mean processing delay over time is approximately 275 ms.

² The data used in characterizing the cursor system delay was obtained from various documentation provided by the B-2 SPO including "MDS Display Control Processor" SDRD MS2 Part III ID3551A, MDS DCP OFF SDRS MSII Part III 14 Aug 1991 IFC F1, Critical Item Development Specification for Avionics C&D subsystem EAA335OV001 16 Aug 86, and with discussions between Mr. Rick Detar of Northrop Corp. and Mr. Roger Overdorf of SAIC. The system design was refined upon receipt of the "Radar Cursor Investigation" memorandum from Northrop Corp. dated 31 July 1992.

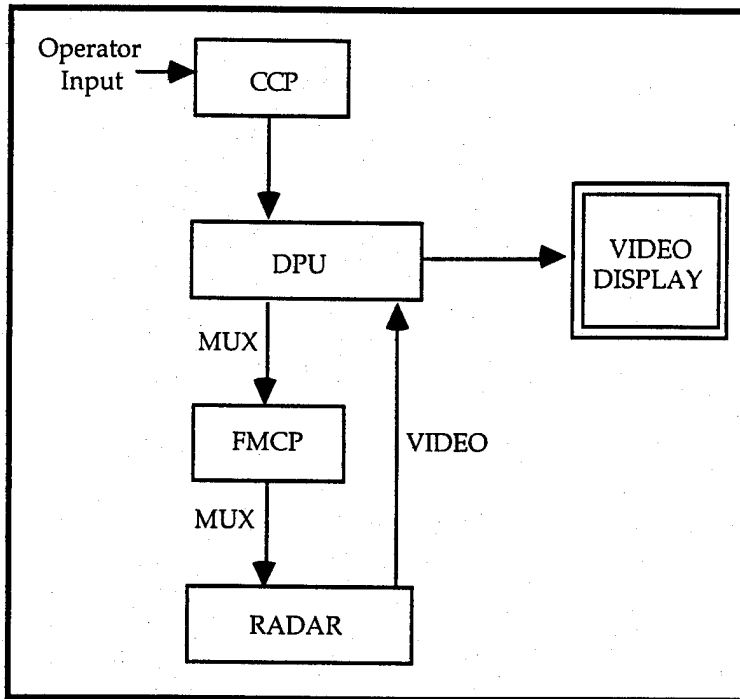

Figure 1-4. B-2 radar cursor system data processing path

Table 1-1. B-2 Radar Cursor System Data Transport Delay

Component	Nominal Frame Rate	Minimum Processing Time (ms)*	Maximum Processing Time (ms)*
CCP	60 Hz	17	33
DPU	16 Hz	63	63
FMCP	16 Hz	16	78
Radar	20 Hz	50	200
Radar Video to DPU	30 Hz	33	33
Total		179	407

* Processing times are rounded to nearest ms.

SECTION II

Development of Alternative Gain Function for Use in Experimentation

Based on performance and subjective data from previous research (Irvin et al, 1993), as well as aircrew comments in the Radar Cursor Controller Slew service report (Material Improvement Project #20198), it was apparent that the current cursor system gain function is inadequate to allow rapid and accurate fine cursor positioning. Thus, an effort was undertaken to identify a new gain function that would allow more fine-positioning control without sacrificing the ability to perform rapid gross positioning. With limited time and resources, a direct approach to developing an alternative gain function was taken. This approach was used to design and evaluate candidate alternative gain functions based on principles of control theory, subject matter expertise, and empirical evaluations in a rapid prototyping environment. For a detailed description of the gain function development, see Appendix A. The result of this effort was the selection of an alternative gain function to be tested against the current function. This function, referred to as the "Alternative" function, is shown below in Figure 2 -1.

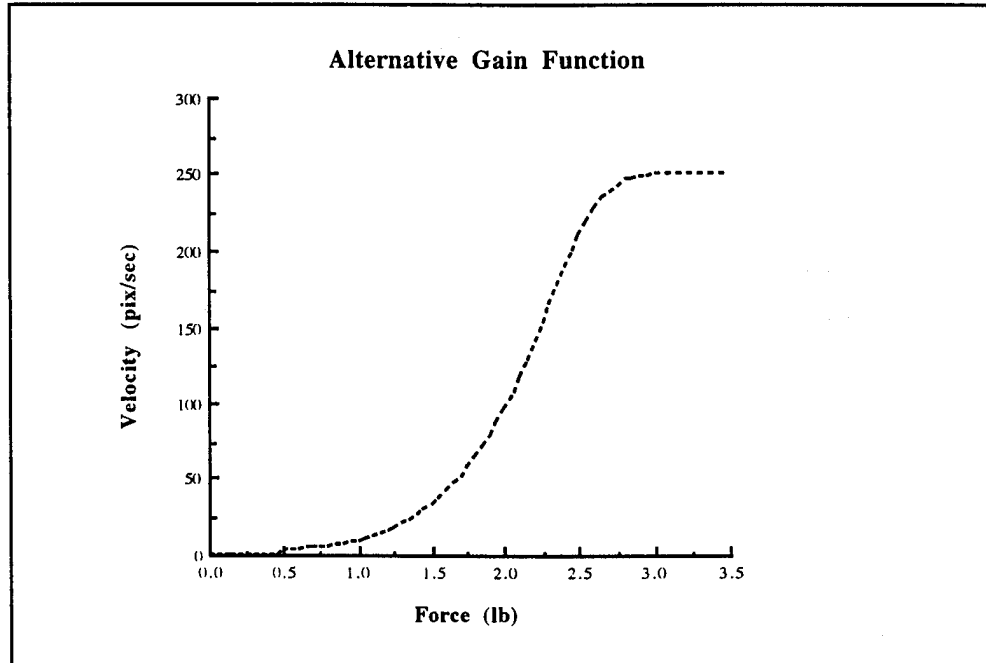

Figure 2-1. Alternative B-2 radar-embedded cursor system gain function.

Like the gain function currently driving the B-2 radar-embedded cursor (the "Current" function), the Alternative function initiates cursor movement after a breakout force of 0.5 lb has been exceeded. Similarly, it achieves a maximum cursor velocity at 3.0 lb of input force. Rather than being a simple linear function, however, the Alternative function consists of a sigmoidal or S-shaped curve. This serves to lower the gain at lower input forces, thereby creating a less sensitive fine positioning region of the curve; while increasing the gain associated with higher input forces, which increases sensitivity in the gross positioning region of the curve. In addition, the maximum cursor velocity attainable with the Alternative function is 250 pix/s compared to a maximum velocity of 191 pix/s attained with the Current function. Figure 2-2 shows both the Current and Alternative functions for comparison.

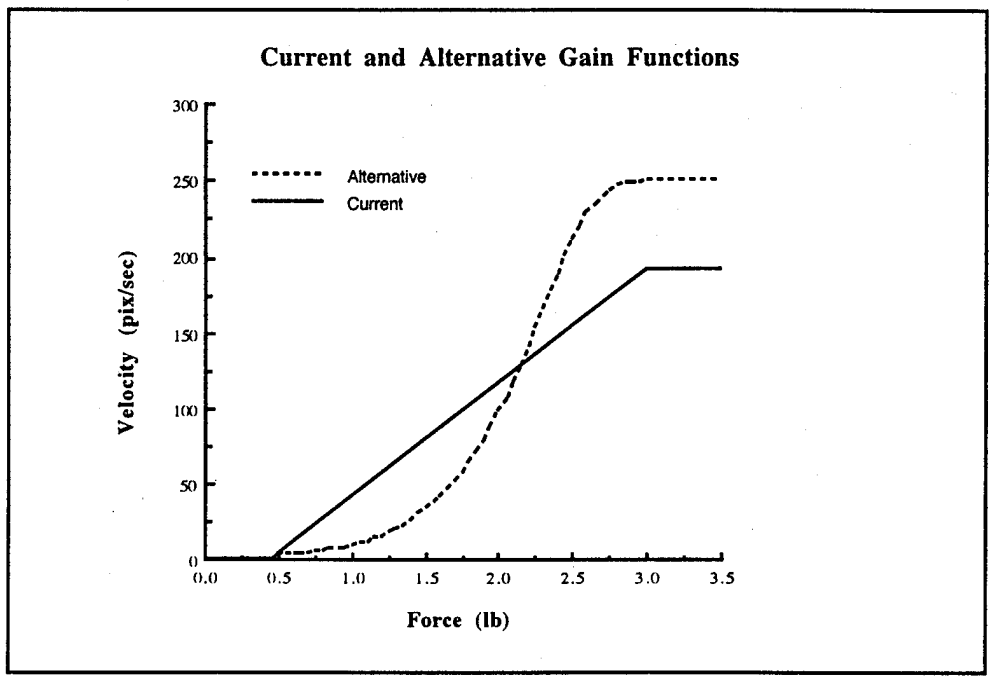

Figure 2-2. Current and Alternative B-2 radar-embedded cursor system gain functions. The Alternative function consists of a lower gain at low input forces for controlled fine positioning, and a higher gain at high input forces for rapid gross positioning.

SECTION III

Approach

The current investigation compared operator aimpoint designation performance using the Current linear cursor system gain function to performance using the S-shaped Alternative function described in the previous section. The testing scenario included only the Mission Commander's station (i.e., the right-hand seat), in which the cursor control panel was actuated with the right thumb. A thorough evaluation of the two gain functions involved testing in both a SAR navigational update scenario, which required only fine positioning of the cursor, as well as a semi-operational GATS targeting scenario, which required both gross and fine cursor positioning. The primary goal of the investigation was to evaluate operator performance with the Current and Alternative cursor processing gain functions in these two scenarios. In addition, the effect of variability in processing delay was of interest. However, a third factor known to impact performance had to be considered. This factor was the degree to which subjects were cued to the actual target pixel (i.e., whether or not the target pixel was highlighted and thus, unambiguous). Discussions of both target pixel cueing and processing delay variability are presented below.

Target Pixel Cueing.

When performing an operational designation task on SAR imagery, operators must perform some degree of image interpretation. In order to place the cursor on an aimpoint, they must interpret the imagery and decide which pixel best represents the desired aimpoint. For tasks such as performing a navigational update, operators refer to a radar fix point (RFP) card to determine a desired aimpoint. The RFP card consists of an aerial photograph of a target area with a verbal description of a specific aimpoint. On the radar display, the operators see a radar depiction of the same target area. They then attempt to position the cursor on a point on the radar image that corresponds to the aimpoint shown and described on the RFP card.

Designation accuracy on a task such as this can be difficult to measure due to a significant amount of extraneous error introduced by the activity of RFP card image interpretation. That is, the placement accuracy of the cursor on the radar screen is a function of the operator's interpretation of the aimpoint on the RFP card and his ability to find the exact corresponding location on the radar image. Therefore, variability in radar aimpoint selection introduces a source of designation error that is unrelated to the operation of the cursor control system. One goal of this investigation was to determine the magnitude of this imagery interpretation

error as well as to remove this source of error from performance measures obtained with both cursor system gain functions. To accomplish this, a target pixel cueing variable was introduced. This variable consisted of two levels, uncued target pixel and cued target pixel. The uncued target pixel condition represented an operationally realistic designation task in which operators were required to refer to an RFP card and to interpret the SAR imagery to identify an aimpoint. In the cued target pixel condition, however, the target pixel was highlighted on the SAR imagery, such that the operator needed only to move to and designate the highlighted pixel. This was intended to remove any ambiguity regarding which specific pixel was to be designated, and to help isolate any effects of cursor system gain function.

Cursor Processing Delay Variability.

As was discussed earlier, the current B-2 radar-embedded cursor system has a variable system delay with a mean delay estimated to be approximately 275 ms. It was hypothesized that variability in processing delay, due to its unpredictability, would result in poorer designation performance than would a constant or fixed processing delay. Thus, in one condition, performance with a variable processing delay was examined. In this condition, which modeled the delay characteristics in the aircraft, the processing delay varied randomly within trials from a minimum of 188 ms to a maximum of 434 ms, with a mean processing delay of 250 ms (due to data transport limitations, a delay of 275 ms could not be simulated). In a second condition, a *fixed* processing delay of 250 ms was implemented.

Experimental Design

In addition to gain function (current vs. alternative), effects of target pixel cueing (cued vs. uncued), and processing delay variability (fixed vs. variable), two operational scenarios (navigational update and GATS targeting) were of interest. A full factorial design with four variables would have involved a relatively high level of complexity and would have required unacceptably long experimental sessions to collect sufficient amounts of data. Therefore, the investigation was divided into two separate two-factor experiments described below.

Experiment 1: Experiment 1 examined the effects of gain function (current vs. alternative) and target pixel cueing (cued vs. uncued) on cursor positioning performance within a SAR navigational update scenario. For all conditions in Experiment 1, a variable processing delay, approximating the mean and range of delay in the aircraft, was implemented.

The B-2 radar system allows the operator to examine any of five radar map sizes. The navigational update task typically requires only fine positioning of the cursor, even on the high resolution maps. At the request of the B-2 SPO, the current investigation modeled the second highest radar image resolution. At this resolution, the typical error in the navigation system was estimated to range between four and seventeen pixels. Thus, on any given trial, the target pixel was offset from the initial cursor position (i.e., the center of the screen) by a distance of four to seventeen pixels, requiring only a small movement of the cursor.

The subjects' ability to position the cursor over the target pixel was measured along three dependent variables: *designation time*, *designation error* and *overshoots*. The primary measures of interest associated with a manual control task are typically speed and accuracy of the control input. With regard to the current investigation, two types of accuracy were examined. The primary performance measure for purposes of gain function evaluation was the accuracy associated with the final aimpoint designation (i.e., designation error). Designation error was defined as the distance between the target pixel and the pixel that was designated. This was calculated using the following equation:

$$Error_d = \sqrt{(Error_x)^2 + (Error_y)^2}$$

where *Error_d* is the designation error (in pixels), *Error_x* is the error on the x or horizontal axis, and *Error_y* is the error on the y or vertical axis.

In addition, however, the accuracy of the slewing movements *prior* to designation were examined. This measure of cursor controllability was assessed by recording the number of times the subject would overshoot the target pixel. The number of overshoots was defined as the number of times that the cursor-to-target pixel distance *increased* after previously *decreasing*. In most cases, speed and accuracy exhibit an inverse relationship or trade-off, such that the faster an input is performed, the less accurate it will be. However, in examining overshoots, a *positive* correlation between slewing accuracy and designation time would be expected. This is because each overshoot requires a subsequent control input to correct it. This additional performance measure was included to help characterize operators' ability to accurately position the cursor.

Designation time was simply defined as the elapsed time from trial onset (i.e., when the radar image first appeared) until a point on the image was designated.

Experiment 2: Like Experiment 1, Experiment 2 was intended to evaluate cursor positioning performance with the Current and Alternative gain functions. However, the second experiment was designed to address a different type of cursor slewing task. Unlike Experiment 1, which modeled a SAR navigational update task and required only a short cursor slewing distance (4 to 17 pixels) to a single target, Experiment 2 was designed to model a weapons targeting task in which the cursor had to be slewed over a longer distance. In addition, Experiment 2 required designation of four independent targets on each radar image. Thus, for each target on a given trial, the subject was required to perform both *gross* and *fine* cursor positioning on four designation events. The *fine positioning* component of the task was considered to be final cursor movement within a 17-pixel radius of the target pixel (the maximum slewing distance required in Experiment 1). Any cursor movement that occurred outside this 17-pixel radius from the target pixel was considered to be an act of *gross positioning*. The distance between targets on each image and the initial position of the cursor was set such that subjects were required to slew the cursor a distance of at least 117 pixels to reach each target. Thus, the gross positioning component of the slewing task required a minimum cursor slew of 100 pixels.

In addition to evaluating the Current and Alternative gain functions, Experiment 2 was used to examine the effects of cursor processing delay variability (fixed vs. variable), resulting in a 2 x 2 (Gain Function x Processing Delay Variability) experimental design. For this experiment, all target pixels were highlighted, thereby reducing aimpoint ambiguity and isolating the effects of interest.

Like Experiment 1, Experiment 2 examined performance measures including *designation time*, *designation error*, and *overshoots*. However, because each trial in Experiment 2 required designation of four targets, designation time was calculated for each designation event (i.e., four times per trial). The onset of designation time was initiated by either of the following conditions: 1) the SAR image first appearing on the screen (for the first designation event of a trial); or 2) the designation of the previous target on a single image (for the second, third, and fourth target designation events within a trial). The time between this onset event and designation was considered to be the event designation time. In addition, because Experiment 2 used a task requiring both gross and fine cursor positioning, the dependent variable designation time was further reduced to individual components of

gross positioning time and *fine positioning time*. Gross positioning time was defined as the time between onset of the designation event and the time at which the cursor last entered into a 17-pixel radius of the target pixel. The elapsed time between the cursor's final entrance into this radius and designation was considered to be the fine-positioning time. Similarly, *gross positioning overshoots* and *fine positioning overshoots* were examined separately. Gross positioning overshoots consisted of overshoots that resulted in a maximum cursor-to-target distance of greater than 17 pixels. Fine positioning overshoots were defined as overshoots that resulted in a cursor-to-target distance of 17 pixels or less. Table 3-1 outlines the independent and dependent variables examined in Experiments 1 and 2.

Table 3-1. Independent and Dependent Variables in Experiments 1 and 2

Experiment	Independent Variables	Dependent Variables
Experiment 1 (Navigational update task)	Gain Function 1. Current 2. Alternative Target Pixel Cueing 1. Uncued 2. Cued	Designation Time Designation Error Overshoots
Experiment 2 (Targeting task)	Gain Function 1. Current 2. Alternative Processing Delay Variability 1. Variable 2. Fixed	Designation Time (total) Gross Positioning Time Fine Positioning Time Designation Error Overshoots (total) Gross Positioning Overshoots Fine Positioning Overshoots

Data from both Experiment 1 and Experiment 2 were collected in a single session. The conduct of the experiments was counterbalanced such that half of the subjects performed Experiment 1 before Experiment 2. The remainder performed Experiment 2 first.

SECTION IV

Experiment 1: SAR Navigational Update Task

Method

Subjects: Sixteen adult males participated as subjects in this study. The subjects consisted of current or previous USAF crew members with some degree of radar/navigation experience. Subject experience, ascertained through self-report, is outlined in Table 4-1.

Table 4-1. Subject Background and Experience

Aircraft Experience	Number of Subjects	Average (hrs)	Crew Position	Number of Subjects	Sensor Experience	Number of Subjects	Average (hrs)
B-2	9	79	Pilot	11	SAR	11	280
B-1	7	787	RN	5	EVS/FLIR	10	1368
B-52	13	1448	OSO	4			
F-111	5	1290	NAV	3			
Other*	13	953	WSO	2			

* Other Aircraft Experience Included C-5, C-17, C-141, F-16, KC-135, T-37, T-38 and T-39

As a whole, the subjects possessed a good deal of flight experience, with the average subject having over 2700 total flight hours. Subjects varied widely in the aircraft they had flown as well as their crew position; however, the B-2 pilot community was well-represented. Of the sixteen subjects participating in the study, nine (56%) had experience in the B-2. In addition, eleven of sixteen (69%) had operational experience with SAR imagery.

Apparatus: The experimentation was conducted using the Prototyping and Evaluation Station (P&ES) resident at Armstrong Laboratory. This system, used for rapid prototyping and evaluation of cockpit controls and displays, was specially configured to support part-task simulation of SAR navigational updates and targeting in the B-2 Mission Commander's station. Critical equipment included the following five distinct hardware elements:

- a. Silicon Graphics 4D-320 workstation for image generation and cursor display.
- b. Zenith Z-248 PC (linkage computer) for sampling of subject activity.

- c. VT-220 terminal connected to the SG as an operator console.
- d. 6" x 6" Multipurpose Display Unit (MDU).
- e. Right-handed Cursor Control Panel (Mason Electric #0002C).

The configuration of this hardware is depicted in Figure 4-1. The simulated SAR imagery, generated via software in the SG, was presented to subjects on a 1024 x 1024 pixel non-interlaced MDU display. To mimic the resolution of actual cockpit MDU's, however, all imagery presented on the MDU underwent a pixel replication technique that artificially created a full-screen 512 x 512 pixel image. Similarly, the control software was modified such that the cursor moved in 512 discrete steps vertically and horizontally across the MDU screen. Additional hardware and software were incorporated into the B-2 P&ES, allowing the linkage computer to accept subject inputs from the cursor control panel.

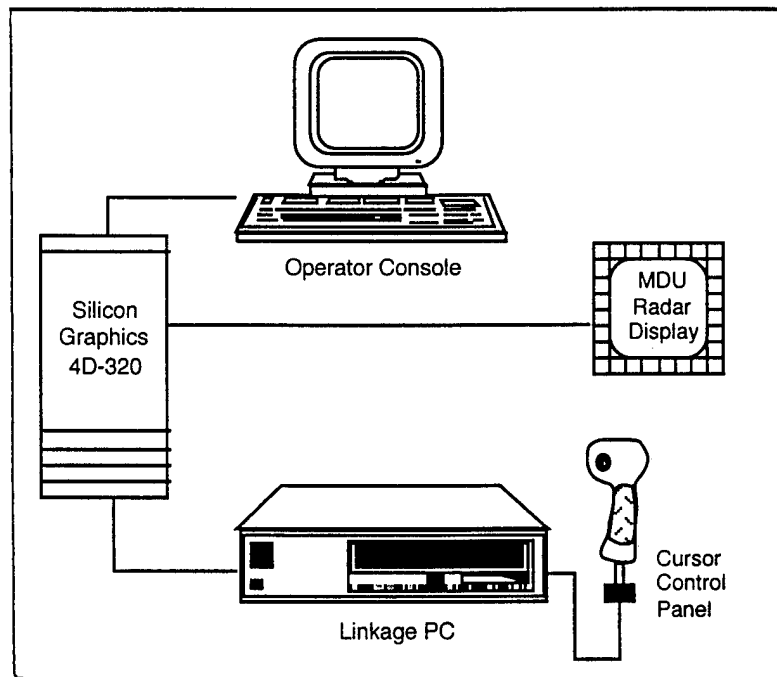

Figure 4-1. Experimentation hardware configuration.

The variable processing delay in the cursor system was modeled by artificially delaying cursor positioning updates to the MDU. As cursor control inputs were received from the Linkage PC, they were stored in a queue in the SG. This data was then sent to the MDU at variable delay intervals corresponding to the length of 3-7 frame updates. Using this technique, the possible delay times were restricted to multiples of 62.5 ms (i.e., 1 frame at 16 Hz). To approximate the maximum and minimum delay lengths in the B-2 system (i.e., 179 ms and 407 ms, respectively), a 3-frame delay (188 ms) and a 7-frame delay (438 ms)

were chosen as the minimum and maximum delays to be implemented in the Variable System Delay conditions, including all Experiment 1 trials. The distribution of delay between this minimum and maximum was in the form of a truncated Gaussian curve such that, within a trial, the MDU screen updates were delayed by approximately 250 ms (4 frames), approximating as closely as possible the estimated 275 ms mean delay in the aircraft. Table 4-2 shows the distribution of video update delay between 3 and 7 frames.

Table 4-2. Magnitude and Distribution of Simulated Variable Processing Delay

Delay (frames)	Delay (ms)	% of Video Updates with each Delay
3	188	29%
4	250	34%
5	313	24%
6	375	10%
7	438	03%

Stimuli: Simulated SAR Imagery: The primary stimuli used in the experiment consisted of simulated SAR imagery produced by a High-Resolution Ground Mapping Radar Simulator. This system incorporates an improved Digital Radar Landmass Simulator (DRLMS) database, United States Geological Survey (USGS) high-altitude photographic data, and a variety of commercially-available hardware and software products to create an image synthesization process capable of generating simulated high-resolution radar images. A total of 25 unique simulated SAR images were developed for use as stimuli in the experiment. Figure 4-2 shows a representative SAR image used in the uncued target pixel condition in Experiment 1. An example of imagery used in the cued target pixel condition is shown in Figure 4-3. In experimental conditions in which the SAR imagery contained cued (i.e., highlighted) target pixels, the target pixel was drawn in red on the radar display. A red circle with a diameter of seventeen pixels and a stroke width of two pixels was drawn around the target pixel. This served to quickly draw the subject's attention to the aimpoint area and the target pixel.

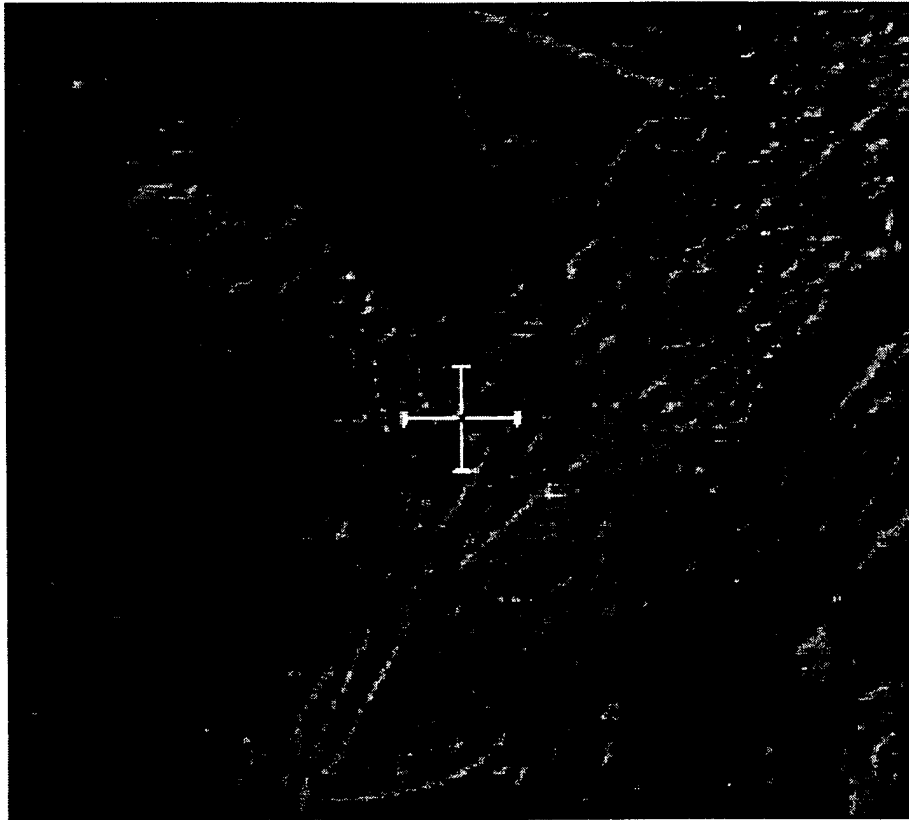

Figure 4-2. Example of SAR imagery used in uncued target pixel condition.

Stimuli: RFP Cards: Additional stimuli consisted of radar fix point (RFP) cards, which the subjects examined to identify the aimpoints in the uncued target pixel conditions. These RFP cards were generated directly from the USGS photo imagery. Each RFP card contained a verbal description of the target and a small circle drawn around the target in the photo. In the center of that circle, a single point was highlighted with a black dot. This dot represented the precise aimpoint that subjects were instructed to designate, and corresponded to a target pixel on the SAR image against which designation error was measured. An example of an RFP card is shown in Figure 4-4.

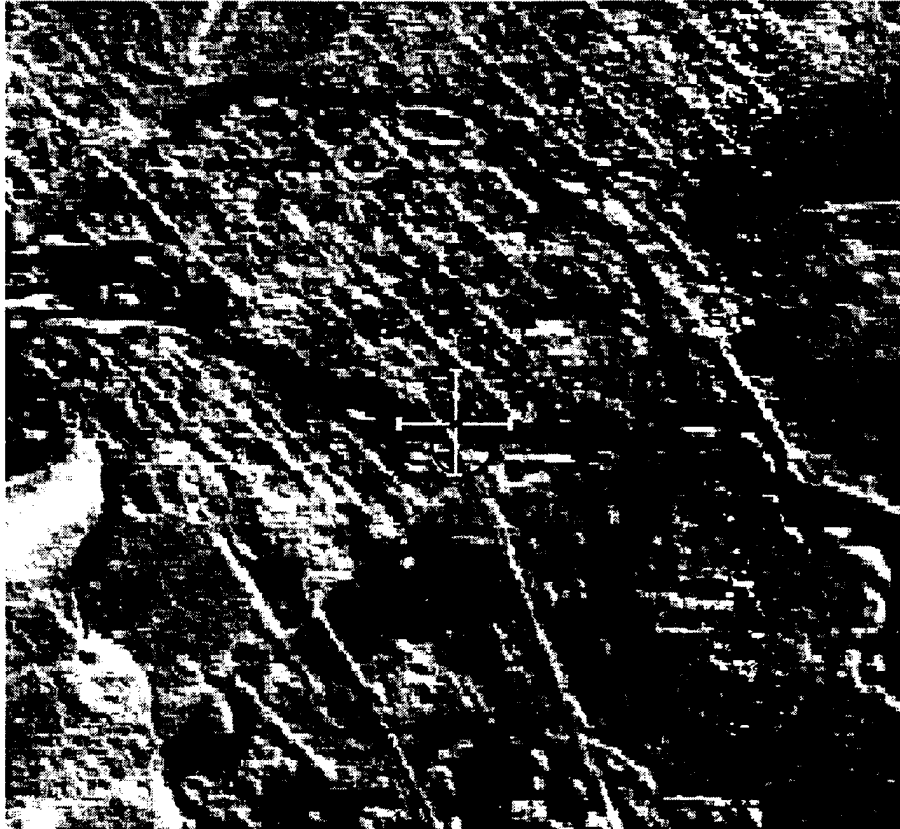

Figure 4-3. Example of SAR imagery used in cued target pixel condition.

Procedure: Performance Data Collection: Prior to running in the experimental session, subjects read a brief set of instructions (see Appendix B). The instructions outlined the experimental procedures that subjects would perform and stressed that performance would be evaluated on the basis of both speed and accuracy, with no bias being given toward one or the other. Subjects were then seated in front of the MDU and familiarized with the cursor control panel mounted to their right. Subjects were instructed to sit at a comfortable distance from the monitor, and no specific viewing distance was imposed. This design decision was made after talking to a number of B-2 crew members who stated that operators lean forward to various degrees when performing navigational updates. These operators noted that sitting posture, and therefore viewing distance, varies across crew members.

AIM POINT GRAPHIC		UNCLASSIFIED	WGS GEODETICS	-84	AP NO 56901
AP NO	WAC-SH-PLOT 267-07-CP		46-35.018N		
			107-22.575W	ELEVET MSL 03175	
					
			POINT DESCRIPTION DSC		CHART GEODETICS 46-35-04N 107-22-26W
			Center of Bridge		
			REF CHART/SCALE	HOR ACC	WAC-SH-PLOT 267-07 CP
			5/200 ATC	EI 90S 0177	
			1:200,000	VER ACC	
			PHOTO DATE	EI 90S MSL	
			AUG 88	115	
				AIMG PUB DATE	
				21 APR 89	
UNCLASSIFIED					
SAC FORM 444 MAR 87					

Figure 4-4. Example of RFP card used in uncued target pixel condition.

Four blocks of trials were performed, representing the four possible combinations of gain function and target pixel cueing in Experiment 1. Each block consisted of five practice trials followed by twenty actual trials. Block order was counterbalanced across subjects to account for practice effects. Prior to each block, subjects were told which gain function was being used. The Current and Alternative gain functions were referred to only as "Function A" and "Function B" respectively, so that the subjects were not aware of which function was currently in the aircraft and thereby preventing an *a priori* bias.

In the uncued target pixel condition, subjects examined an RFP card until they were familiar with the target area and the desired aimpoint. At that time, they pressed a button on the cursor control panel, initiating a trial. After a brief pause, a simulated SAR image appeared on the MDU and a clock began recording the elapsed trial time. As the image came up, the cursor appeared in the center of the screen, offset from the target pixel by a random distance between four and seventeen pixels. This was determined to be representative of the average offset error in the B-2 navigational system for the given map size. Having been instructed to designate the target pixel as quickly and accurately as possible, subjects used the cursor controller to slew the cursor to the point on the screen that they felt most closely corresponded to the pixel highlighted on the RFP card photo. Once the cursor had been positioned in the desired location, subjects pulled a trigger on the cursor control panel to end the trial. This process was repeated until points on all twenty-five images had been designated with each gain function.

In the cued target pixel condition, the RFP cards were not used. Once the subjects initiated a trial, the SAR image appeared on the MDU; however, in this condition, the target pixel was colored red, as was a circle that surrounded the immediate target area. Subjects were instructed to slew to and designate the red pixel as quickly and accurately as possible. As in the uncued target pixel Condition, subjects performed 25 trials with each gain function.

Subjective Data Collection: After all four blocks of Experiment 1 were completed, subjects were asked to respond to a set of questions from a questionnaire before continuing on to Experiment 2 or being dismissed. A copy of the full questionnaire, including questions relating to Experiment 2, is presented in Appendix C. The main purpose of the questionnaire was to assess the operator's opinion of the two gain functions. In addition, however, the survey provided a means to evaluate the fidelity and validity of the simulated navigational SAR update task. For Experiment 1, the questions addressed four areas. First, subjects were asked to provide some biographical information outlining their flight experience. Next, questions were asked regarding the realism of the simulated SAR update procedures and imagery. The third section addressed the subjects' perceived accuracy on the uncued target pixel trials. The final set of questions required subjects to rate the relative level of difficulty associated with cursor positioning using Functions "A" and "B" (i.e., the Current and Alternative gain functions, respectively). With the exception of the biographical information, which was provided in written form by the subjects, all information was elicited in an interview format. The experimenter read the questions to the subjects and subject responses were audio recorded.

Results

Performance Data: Within each block in Experiment 1, subjects performed twenty designation events (excluding five practice trials). Across sixteen subjects, this resulted in a total of 320 observations for each of the four experimental conditions. As was anticipated, both the gain function and target pixel cueing variables impacted subjects' ability to perform the target designation task. This section describes the effects of gain function and target pixel cueing on each of the performance measures.

Designation Error: Figure 4-5 shows the mean designation error for each gain function in both the uncued and cued target pixel conditions. Figure 4-6 shows designation error for each gain function collapsed across target pixel cueing conditions (4-6a), and for each target pixel cueing condition, collapsed across gain function (4-6b). As shown in Figure 4-6a, designation error did not appear to be affected by gain function. The Current gain function elicited a mean designation error of 1.36 pixels, compared to a mean designation error of 1.35 pixels elicited by the Alternative function. As expected, however, target pixel cueing greatly impacted subjects' ability to accurately designate the target pixel (see Figure 4-6b). In the uncued target pixel condition, subjects missed the target pixel by a mean distance of 2.32 pixels. When the target pixels were cued, however, this designation error was reduced to a mean of 0.38 pixels. The significance of these performance differences was analyzed using a Gain Function x Target Pixel Cueing Analysis of Variance (ANOVA). This analysis revealed a significant ($\alpha = .05$) effect of target pixel cueing ($F(1,15) = 197.69, p < .0001$). The significant increase in designation error in the uncued target pixel condition demonstrates the degree to which subjects had difficulty determining the specific pixel on the radar screen that corresponded directly to a given point on the photographic image. The ANOVA revealed no main effect of gain function on designation error, nor did it reveal a gain function by target pixel cueing interaction.

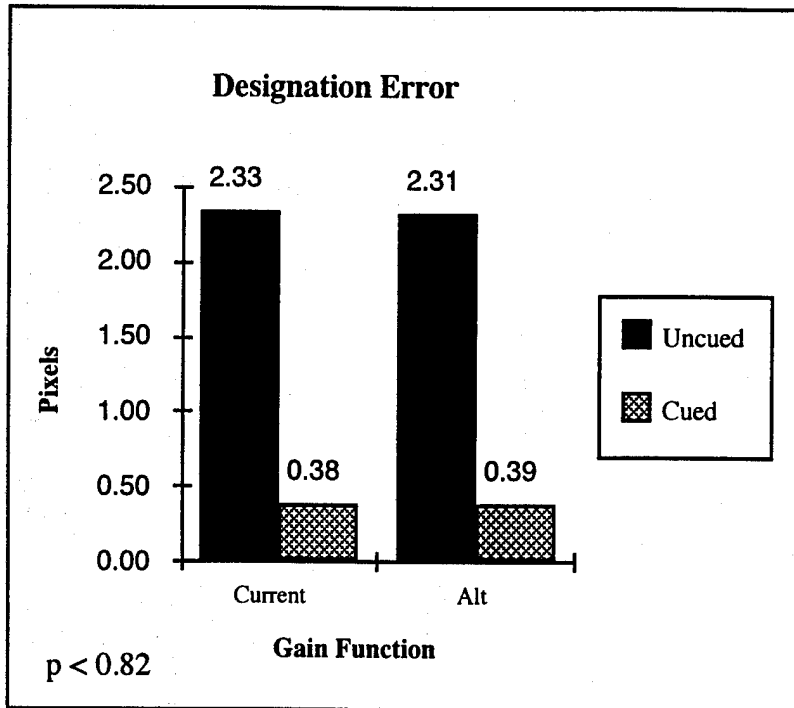

Figure 4-5. Mean effects of gain function on designation error for each level of target pixel cueing.

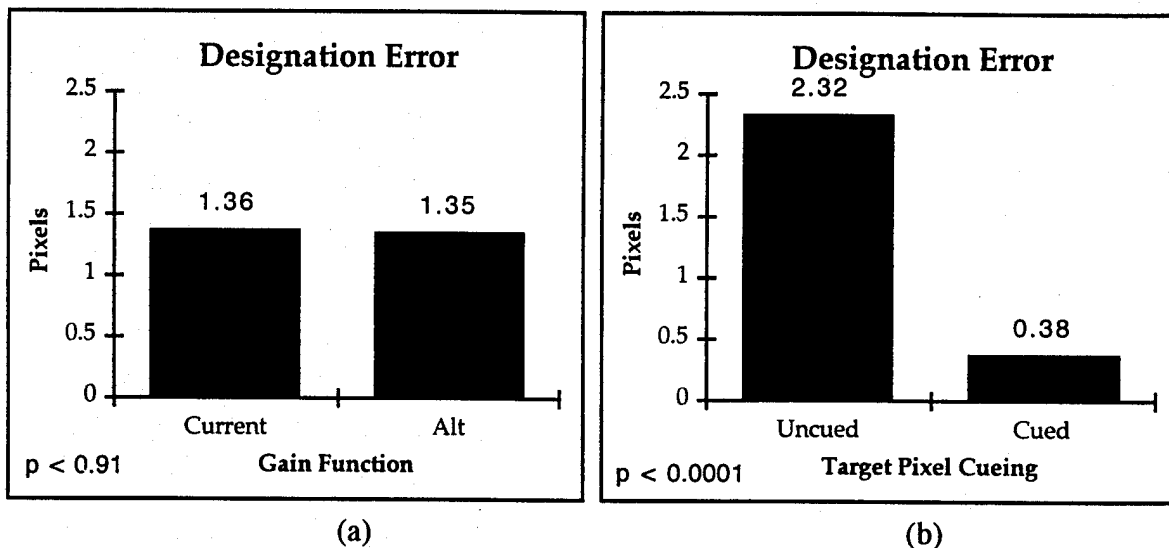

Figure 4-6. Mean effects of gain function (a) and target pixel cueing (b) on designation error. Effects of gain function are collapsed across target pixel cueing conditions (a), and effects of target pixel cueing are collapsed across gain functions (b).

Designation Time: Mean designation time elicited with each gain function in each target pixel cueing condition is shown in Figure 4-7. Across target pixel cueing conditions, designation time was lower with the Alternative gain function than with the Current gain function, decreasing from a mean time of 11.64 s to 10.01 s (see Figure 4-8a). This represents a 14% reduction in designation time achieved by the Alternative function. Similarly, designation time was influenced by the target pixel cueing. In the uncued target pixel condition, which required subjects to estimate the aimpoint using the RFP card, Designation time averaged 11.51 s across gain functions (see Figure 4-8b). In the cued target pixel condition, however, mean designation time was reduced to 10.14 s, a decrease of 11.9%.

The significance of these performance differences was analyzed using a Gain Function x Target Pixel Cueing ANOVA. The ANOVA revealed significant main effects of both gain function ($F(1,15) = 29.81, p < .0001$) and target pixel cueing ($F(1,15) = 5.02, p < .041$) on designation time. An apparent interaction between gain function and target pixel cueing, shown in Figure 4-7, failed to achieve statistical significance ($F(1,15) = 4.03, p < .0632$).

Overshoots: Both gain function and target pixel cueing were found to impact the number of overshoots that occurred on each trial (see Figure 4-9). Collapsed across target pixel cueing conditions, the Current gain function elicited a mean of 2.35 overshoots per trial. This number was reduced to a mean of 1.76 overshoots when the Alternative function was used (see Figure 4-10a). Similarly, when collapsed across gain function, overshoots were reduced from a mean of 2.35 in the uncued target pixel condition to 1.76 in the cued condition (see Figure 4-10b). Both gain function ($F(1,15) = 23.42, p < .0002$) and target pixel cueing ($F(1,15) = 5.78, p < .0296$) were found to be significant main effects. As shown in Figure 4-9, the ANOVA also revealed a significant interaction between gain function and target pixel cueing ($F(1,15) = 7.72, p < .0140$). The interaction indicates that the effect of gain function upon overshoots was minimal when target pixels were uncued, with the Current and Alternative gain functions resulting in 2.46 and 2.24 overshoots, respectively. However, when the target pixel was cued, and therefore unambiguous, the effect of gain function was much greater. In the cued target pixel condition, the Current gain function elicited a mean of 2.24 overshoots, whereas the Alternative function yielded a mean of only 1.28 overshoots.

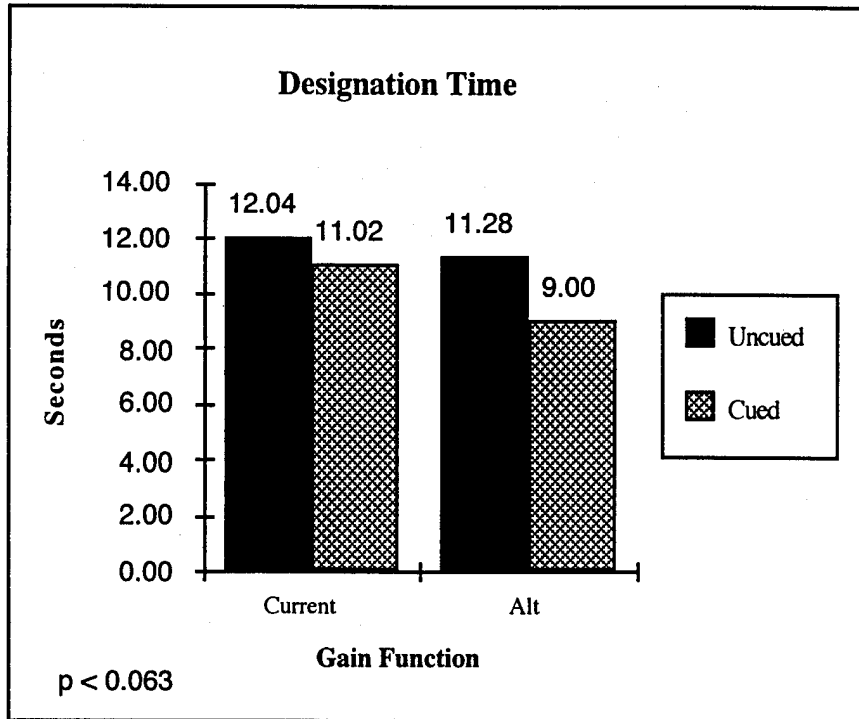

Figure 4-7. Mean effects of gain function on designation time for each level of target pixel cueing.

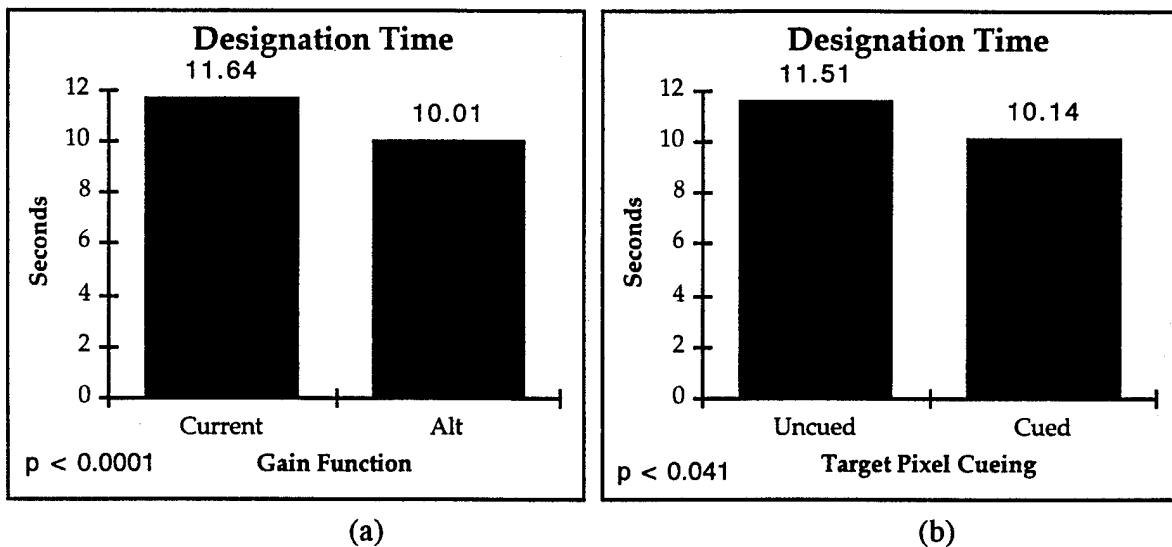

Figure 4-8. Mean effects of gain function (a) and target pixel cueing (b) on designation time. Effects of gain function are collapsed across target pixel cueing conditions (a), and effects of target pixel cueing are collapsed across gain functions (b).

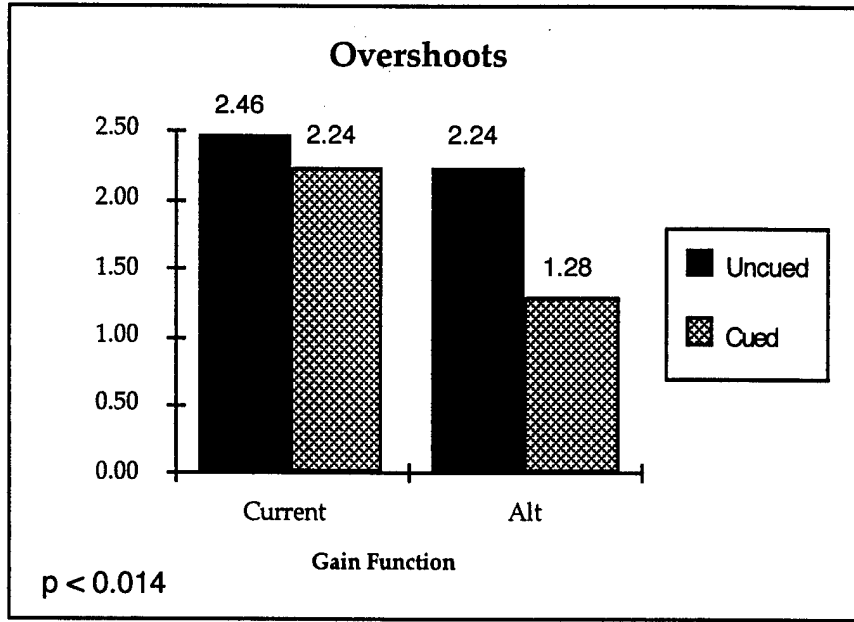

Figure 4-9. Mean effects of gain function on overshoots for each level of target pixel cueing.

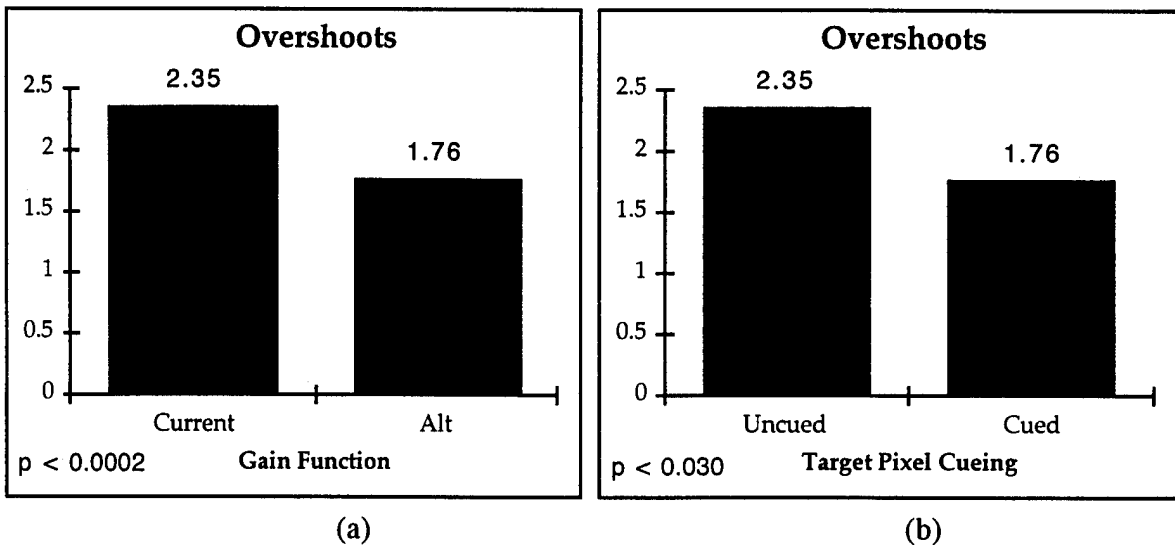

Figure 4-10. Mean effects of gain function (a) and target pixel cueing (b) on overshoots. Effects of gain function are collapsed across target pixel cueing conditions (a), effects of target pixel cueing are collapsed across gain functions (b).

Subjective Evaluations: As an additional means of evaluating subjects' performance as well as attributes of the simulated SAR navigational update task, a questionnaire was administered to subjects after they completed Experiment 1. Subjects' responses to the questionnaire are summarized below.

Simulation Fidelity: Subjects were asked a series of questions relating to the fidelity of the procedures and stimuli. The questions required subjects to rate the experimentation on such aspects as the realism of the simulated SAR imagery, the appropriateness of the aimpoints selected, and the fidelity of the procedure used for performing the SAR update task. Table 4-3 lists these questions and summarizes the mean responses across subjects.

Table 4-3. Subjective Evaluation of Simulation/Experimentation Fidelity.

Question	Number of Respondents *	Maximum Possible Rating	Mean Response
Overall, how would you rate the realism of the simulated SAR imagery presented during the demonstration?	16	3.00	2.69
What simulated SAR effects/characteristics would you improve?	16	Open-ended	**
Do you feel the aimpoint types (tanks, bridges, buildings, towers, etc.) selected for the demonstration are typical of those you experience in your operational units?	15	Yes/No	Yes (100%)
How effective was the demonstration in simulating the procedure used for performing radar updates?	14	5.00	4.57

* Some subjects felt unqualified to address certain questions due to lack of experience.

** Subject responses listed in Appendix D.

Although not all aspects of the navigational update task were modeled (i.e., no multiple looks, no zoom capability), responses to these four questions indicated that the simulation achieved a high degree of operational fidelity within the scope of the experimental scenario.

Gain Function Effectiveness: After addressing the fidelity of the simulated navigational update task, subjects were asked to evaluate their performance with the Current and Alternative gain functions in the uncued target pixel condition. Because the target pixel was not highlighted in this condition, only the subjects knew the true pixel that they were trying to designate on a given trial. Thus, it was necessary to elicit subjective evaluations from the operators regarding their perceived accuracy. The series of questions addressing performance in the uncued target pixel condition and the mean subject responses are listed in Table-4-4.

A summary of the subjective evaluations indicated that 50% of the subjects felt that they were always able to place the cursor on the exact pixel that they intended to designate. The remaining 50% of subjects felt that, on a certain percentage of trials, they designated a different pixel than they intended. On average, these subjects felt that when using the Alternative gain function, they *missed* their intended target pixel on 9% of the trials. When using the Current gain function, however, this miss estimate increased to 21%. In addition, subjects estimated a higher miss distance (1.56 pixels) with the Current gain function than with the Alternative function (1.13 pixels).

The next set of questions addressed the level of difficulty associated with fine cursor positioning for each gain function. To elicit subjective opinions of how the gain functions were perceived to affect operator performance on the SAR update task, subjects were asked a series of questions regarding their perceived designation speed, accuracy, and ability to control the cursor movement. These questions and subjects' mean responses are listed in Table 4-5.

Subjective evaluations for this series of questions again showed an operator preference for the Alternative gain function. With the Alternative function, *accurate* positioning of the cursor was rated most closely to being "somewhat easy." With the Current gain function, however, subjects rated accurate positioning as being "somewhat difficult." *Rapid* positioning of the cursor was also rated slightly higher for the Alternative gain function (between "somewhat difficult" and "average") than for the Current function ("somewhat difficult"). As documented in the Radar Cursor Controller Slew service report, aircrews noted an inability to move the cursor one pixel at a time. Therefore, a final question was introduced to address this issue. Only 13% of subjects felt that they could consistently move the cursor one pixel at a time with the Current gain function. However, 94% of the subjects felt that the Alternative gain function allowed them to move one pixel at a time.

Table 4-4. Subjective Evaluations of Performance on the Uncued Target Pixel Task

Question	Summary of Responses						
<p>1) Were you always able to position the cursor on the exact pixel you intended to designate?</p>	<table border="1"> <caption>Data for Question 1 Response</caption> <thead> <tr> <th>Response</th> <th>% Responses</th> </tr> </thead> <tbody> <tr> <td>No</td> <td>50%</td> </tr> <tr> <td>Yes</td> <td>50%</td> </tr> </tbody> </table>	Response	% Responses	No	50%	Yes	50%
Response	% Responses						
No	50%						
Yes	50%						
<p>If "no" to 1: 1a) On approximately what percentage of trials did you fail to designate the pixel you intended to designate?</p>	<table border="1"> <caption>Data for Question 1a Gain Function</caption> <thead> <tr> <th>Gain Function</th> <th>% Trials</th> </tr> </thead> <tbody> <tr> <td>Alt</td> <td>9%</td> </tr> <tr> <td>Current</td> <td>21%</td> </tr> </tbody> </table>	Gain Function	% Trials	Alt	9%	Current	21%
Gain Function	% Trials						
Alt	9%						
Current	21%						
<p>If "no" to 1: 1b) On average, by approximately how many pixels did you miss the pixel you intended to designate?</p>	<table border="1"> <caption>Data for Question 1b Gain Function</caption> <thead> <tr> <th>Gain Function</th> <th>Pixels (means)</th> </tr> </thead> <tbody> <tr> <td>Alt</td> <td>1.13</td> </tr> <tr> <td>Current</td> <td>1.56</td> </tr> </tbody> </table>	Gain Function	Pixels (means)	Alt	1.13	Current	1.56
Gain Function	Pixels (means)						
Alt	1.13						
Current	1.56						

Table 4-5. Subjective Evaluations of the Effect of Gain Function on Fine Cursor Positioning

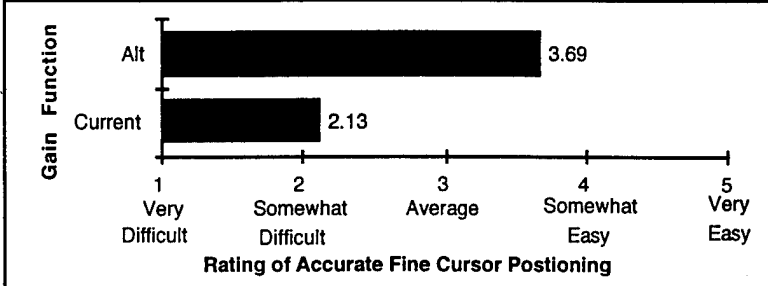
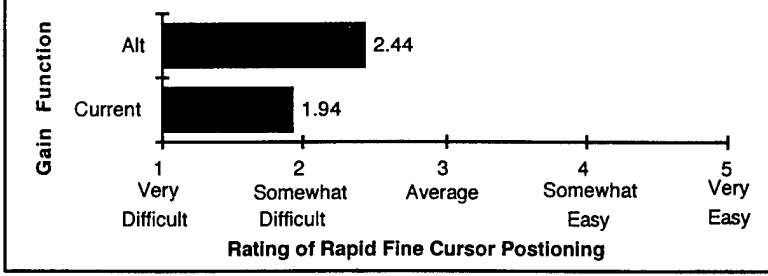
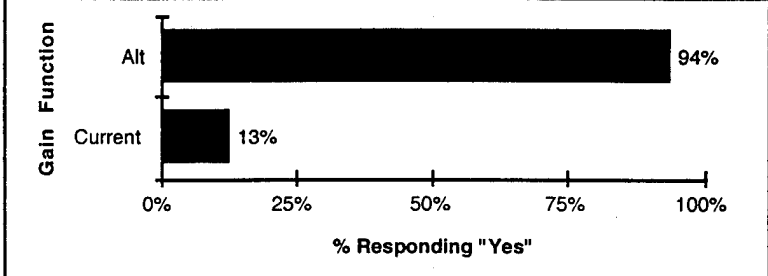
Question	Mean of Responses						
<p>1) Rate the level of difficulty associated with <i>accurately</i> positioning the cursor on the golden pixel.</p>	 <table border="1"> <caption>Rating of Accurate Fine Cursor Positioning</caption> <thead> <tr> <th>Gain Function</th> <th>Mean Rating</th> </tr> </thead> <tbody> <tr> <td>Alt</td> <td>3.69</td> </tr> <tr> <td>Current</td> <td>2.13</td> </tr> </tbody> </table>	Gain Function	Mean Rating	Alt	3.69	Current	2.13
Gain Function	Mean Rating						
Alt	3.69						
Current	2.13						
<p>2) Rate the level of difficulty associated with <i>quickly</i> positioning the cursor on the golden pixel.</p>	 <table border="1"> <caption>Rating of Rapid Fine Cursor Positioning</caption> <thead> <tr> <th>Gain Function</th> <th>Mean Rating</th> </tr> </thead> <tbody> <tr> <td>Alt</td> <td>2.44</td> </tr> <tr> <td>Current</td> <td>1.94</td> </tr> </tbody> </table>	Gain Function	Mean Rating	Alt	2.44	Current	1.94
Gain Function	Mean Rating						
Alt	2.44						
Current	1.94						
<p>3) Did you feel that you were able to consistently move the cursor one pixel at a time?</p>	 <table border="1"> <caption>% Responding "Yes"</caption> <thead> <tr> <th>Gain Function</th> <th>% Responding "Yes"</th> </tr> </thead> <tbody> <tr> <td>Alt</td> <td>94%</td> </tr> <tr> <td>Current</td> <td>13%</td> </tr> </tbody> </table>	Gain Function	% Responding "Yes"	Alt	94%	Current	13%
Gain Function	% Responding "Yes"						
Alt	94%						
Current	13%						

Discussion

Effect of Gain Function on Designation Error: Designation error was found to be unaffected by gain function, suggesting that subjects considered designation accuracy to be a priority over speed. That is, subjects seemed to be willing to take as long as necessary to achieve a given level of accuracy. Consequently, the effects of gain function were manifest in the variables designation time and number of overshoots (which directly impacts designation time).

Effect of Gain Function on Designation Time: Overall, the Alternative gain function resulted in a mean designation time that was 14% shorter than that obtained with the current function. Two performance attributes were observed to affect this difference.

When performing the fine positioning task with the Alternative gain function, subjects generally moved the cursor toward the target pixel at a *slower* rate than with the Current gain function. Initially, this slower movement would seem inconsistent with results showing *faster* designation with the Alternative function. It is reasoned, however, that the faster cursor movement with the Current gain function did not result in faster designation because it caused more overshooting of the target pixel (described later). For every overshoot a subject made, a corrective action had to be taken to move the cursor back in the direction of the target pixel. This additional input action resulted in a longer cursor positioning time prior to designation.

In addition to the time associated with correcting an overshoot, the experimenter observed virtually all of the subjects devoting time to *avoiding* an overshoot. This action was observed frequently when subjects were using the Current gain function. After performing only a few trials with the Current gain function, subjects realized that they were performing a number of overshoots. In an attempt to correct this, they began making very light inputs on the cursor controller. They would tap or "bump" very lightly on the cursor controller, attempting to make an input that would result in one-pixel movement. Not wanting to overshoot the target pixel, often subjects would tap so lightly on the controller that no cursor movement would occur. This light tapping resulted in the input force being smaller than the force required to exceed the 0.50 lb breakout force. On one trial, a subject was observed to make nine consecutive tapping inputs on the controller before exceeding the deadband and registering a cursor movement. This tendency to be overly gentle in making cursor inputs with the

Current gain function, and thereby failing to exceed the force deadband, resulted in “wasted” control inputs, which further increased designation time.

Effect of Gain Function on Overshoots: With the Alternative gain function, 94% of subjects felt that they could consistently make fine positioning inputs that resulted in cursor movement of only one pixel. Only 13% of subjects felt that they had this ability with the Current gain function. This failure to make one-pixel movements invariably resulted in a higher number of overshoots. Frequently, a subject who had positioned the cursor one pixel to the right of the target pixel would make a control input that would result in the cursor resting one or two pixels to the left of the target pixel.

In an effort to better characterize performance and to understand the causes of the observed differences in designation time, one can examine the number of overshoots elicited by each gain function. Performance data revealed that gain function significantly impacted the number of overshoots, with the Alternative function eliciting an average of 1.76 per trial compared to 2.35 overshoots per trial occurring with the Current gain function. A significant Gain Function x Target Pixel Cueing interaction, however, requires a closer look at the data. When subjects used the Current gain function, the number of overshoots was affected only slightly by target pixel cueing. In this condition, cued target pixels elicited 9% fewer overshoots than uncued target pixels (2.24 and 2.46 pixels, respectively). When subjects used the Alternative gain function, however, cued targets elicited 43% fewer overshoots than uncued target pixels (1.28 and 2.24 pixels, respectively.)

One likely explanation for this interaction is the degree of error exhibited in the uncued target pixel condition. For all three dependent variables (designation error, designation time, and overshoots), the uncued target pixel condition resulted in poorer performance than the cued target pixel condition. These effects of target pixel cueing are discussed in detail in the following paragraphs. The amount of error caused by an ambiguous target pixel may have been significant enough to dampen or mask any effects of gain function. With this source of error removed (i.e., in the cued target pixel condition), the effect of gain function on overshoots became much clearer.

Effect of Target Pixel Cueing on Designation Error: Although target pixel cueing significantly impacted all three dependent variables, it was most pronounced on designation error. When the target pixel was cued, subjects' average designation error was only 0.38 pixels. Designation error increased significantly to a mean distance of 2.32 pixels with uncued target pixels. In both target pixel cueing conditions, designation error was unaffected by whether subjects used the Current or the Alternative gain function. These findings have two interesting implications.

First, the low degree of designation error (0.38 pixels) associated with cued target pixels suggests that, if imagery interpretation error is eliminated, the criterion of one-pixel accuracy can be achieved with the Current B-2 cursor system gain function as well as with the Alternative function. This runs contrary to previous aircrew complaints of an inability to achieve one-pixel accuracy with the Current system. One possible explanation for this discrepancy is that the B-2 crew members have not yet flown missions with the new cursor design (i.e., the cursor used in the current experimentation). Thus, previous comments regarding poor designation accuracy with the B-2 radar cursor system may have been, in part, attributed to the sub-optimal cursor design currently in use. This explanation would be supported by the fact that Irvin et al, 1993, found a significant reduction in designation error attributed to the new cursor design. The finding that a 0.38 pixel error can be achieved with either gain function also suggests that higher estimates of designation error obtained in Irvin et al, 1993, in which target pixels were not highlighted, were influenced by some degree of imagery interpretation error due to target pixel ambiguity.

Second, it is interesting to note that, when the target pixel was ambiguous (i.e., in the uncued target pixel condition), designation error was relatively high (2.32 pixels). Conversely, however, subjects' estimates of their designation error in this condition were very low. An estimate of perceived error can be calculated by examining subjective responses in Table 4-3. Analysis of the subjective data showed that 50% of subjects felt they were able to designate the exact pixel they intended to designate on every trial. The remaining 50% of subjects, responded that they felt they missed the intended pixel on only 15% of the trials (averaged across gain function). When this percentage of trials is multiplied by the subjective estimate of designation error on those trials (1.35 pixels, averaged across gain function), a subjective estimate of average designation error can be calculated. This calculation follows.

Subjective estimate of mean designation error :

$$\begin{aligned} &= ((50\% \times 16 \text{ subjects}) \times (15\% \times 40 \text{ trials/subject}) \times (1.35 \text{ pixels/trial})) / 640 \text{ total trials} \\ &= .10125 \text{ pixels/trial} \end{aligned}$$

This calculation shows a subjective estimate of mean designation error to be approximately 0.10 pixels per trial. This suggests that subjects felt that they were achieving a very high designation accuracy, with even lower error than that observed in the cued target pixel condition performance data (0.38 pixels). Such a low estimate of designation error in the uncued target pixel conditions suggests that subjects felt that they were designating their best estimate of the target pixel, and were not relaxing their accuracy criterion by settling for a pixel that they felt was simply “close enough.”

Thus, the perceived low degree of designation error may be attributed to a relaxed *selection* criterion for the target pixel. Subjects may have been unsure of which one of a number of pixels was the actual target pixel, and therefore could have been satisfied with any of them. Since no single pixel was highlighted on the SAR imagery, subjects may have changed their selection criterion to accept any pixel within a given group of pixels surrounding the general aimpoint area as being the actual target pixel. For example, one SAR image required designation of the “center” of a bridge. Even though a single point was highlighted on the RFP card, any one of approximately nine pixels in the SAR imagery might be considered by the subject to be the “center” of the bridge. Thus, the subject could be satisfied, and therefore perform what he felt might be an accurate designation, if he landed on any of those nine pixels. His performance, in terms of accuracy, however, was measured with regard to only a single predetermined target pixel. Therefore, designation of most of the pixels that satisfied the subjects criterion as being the target pixel, would in fact be recorded as a designation error. It is this imagery interpretation error, resulting from an ambiguous target pixel, that is primarily responsible for the 2.32 pixel error in the uncued target pixel condition.

Effect of Target Pixel Cueing on Designation Time: Target pixel cueing also had a significant impact on designation time, yielding mean times of 11.51 s in the uncued condition and 10.14 s in the cued condition. As with the effect of gain function, increased designation time in the uncued target pixel condition is due in part to a higher number of overshoots. However, procedural differences between the cued and uncued target pixel conditions may have also contributed to the difference in designation time. In the uncued

target pixel condition, the subjects were allowed to study the RFP card for an unlimited amount of time prior to the onset of the trial. As a result of examining the image, subjects had a mental representation of the image and aimpoint prior to seeing the SAR image. Thus, upon first seeing the SAR image (i.e., when the timer started), subjects were able to move directly toward the immediate area of the target pixel. Once in the immediate area, however, subjects generally had to glance back at the RFP card once or twice to check the exact location of the aimpoint prior to making final positioning adjustments. The act of looking down at the RFP card, returning attention to the radar display and interpreting the SAR image to find a corresponding aimpoint are all actions that would explain an increased designation time for the uncued target pixel (i.e., operational) condition. In the cued target pixel condition, such actions were not necessary, as the target pixels were always highlighted directly on the SAR imagery.

Effect of Target Pixel Cueing on Overshoots: Overall, the cued target pixel condition also resulted in fewer overshoots than the uncued target pixel condition (1.76 and 2.35 overshoots, respectively). This finding may be explained by the larger designation errors observed in the uncued target pixel condition. On average, subjects missed the target pixel by a distance of over two pixels. If the actual target pixel was between the pixel designated and the initial cursor location, an overshoot would be recorded as the cursor passed by the target pixel. This cursor movement would be recorded as an overshoot regardless of whether the subject overshoot the erroneous pixel that was subsequently designated. In addition, as described earlier, a significant interaction between target pixel cueing and gain function was observed. It appears that the poorer performance associated with an ambiguous or uncued target pixel served to mask the effect of gain function.

SECTION V

Experiment 2: Semi-Operational GATS Targeting Task

Method

Subjects and Apparatus: All sixteen subjects participating in Experiment 1 also participated in Experiment 2. The apparatus used in Experiment 2 was the same as was used in Experiment 1.

Stimuli: To remove any effects of target pixel ambiguity and to isolate the effect of gain function, all targets in Experiment 2 were highlighted. Figure 5-1 shows a representative SAR image from Experiment 2. As shown, each image contained four highlighted target pixels. Because the target pixels were highlighted on the radar screen, RFP cards were not necessary.



Figure 5-1. SAR imagery with four highlighted target pixels

Procedure: In Experiment 2, subjects performed a semi-operational GATS targeting task. Because the GATS system and its employment scenarios are not fully developed, Experiment 2 attempted to model only the nature of the task (i.e., multiple target designation and longer cursor slewing distances). It did not attempt to model the symbology or exact procedures of a GATS targeting task, and therefore, is considered a "semi-operational" simulation of the task. In this task, subjects were asked to designate four targets on a single SAR image. Each subject performed four counterbalanced blocks of trials, representing the possible combinations of two cursor system gain functions and two delay variability conditions. Prior to each block, subjects were informed whether they were using "Gain Function A" (the Current function) or "Gain Function B" (the Alternative function) and whether the processing delay was fixed or variable. Each block consisted of two practice trials and ten data collection trials. This resulted in a total of eight practice and forty data collection trials per block, respectively.

After reading a set of instructions (see Appendix B), subjects began the cursor slewing task. To initiate a trial, subjects pressed a button on the cursor control panel. A SAR image subsequently appeared on the MDU, and a clock started to record elapsed trial time. On the SAR image, one target pixel was highlighted in red and was surrounded by a red circle with a diameter of seventeen pixels. Three additional target pixels were also highlighted and circled in white. The subjects were instructed to slew the cursor to the red pixel and designate as quickly and as accurately as possible. Once a designation was made, the pixel and circle turned white, and a different target pixel and circle turned from white to red. The subjects then proceeded to again slew to the red target pixel and designate. This process was repeated until the subjects had attempted to designate all four target pixels. After four designations had been made, the clock stopped and the trial ended. The subjects then proceeded to the next trial in the block. The starting position of the cursor on the screen and the relative placement of the target pixels on the image required that the cursor always be moved a distance of at least 117 pixels to reach the target pixel. This ensured that for every target, some degree of gross cursor positioning (i.e., cursor movement of at least 100 pixels) had to occur before the cursor entered the fine positioning radius.

As in Experiment 1, subjects were asked to respond to a brief questionnaire upon completing all four blocks in Experiment 2 (see Appendix C, Sections 5 and 6). These questions addressed both the impact of delay variability and gain function on the GATS-like targeting task. After completing Experiments 1 and 2, subjects were asked one last pair of questions

relating to the overall performance of the Current and Alternative gain functions (see Appendix C, Section 7).

Results

Within each block in Experiment 2, subjects performed ten trials. Each trial consisted of four distinct designation events, resulting in a forty designation events per subject (excluding practice trials). Across sixteen subjects, this resulted in a total of 320 observations for each of the four experimental conditions. Dependent variables including designation error, total overshoots, gross positioning overshoots, fine positioning overshoots, designation time, gross positioning time, and fine positioning time were collected and analyzed for each designation event (i.e., four measures per trial).

Designation Error: As was found in Experiment 1, designation error was virtually unaffected by gain function or delay variability (see Figures 5-2 and 5-3). For both gain functions and both delay variability conditions, designation error was found to average approximately 0.37 pixels per target.

Designation Time: Figure 5-4 shows the mean designation time obtained with the Current and Alternative gain functions under each processing delay variability condition. Designation time, which consisted of the total elapsed time for each designation event, was found to be lower for the Alternative gain function than for the Current function (see Figure 5-5a). Averaged across processing delay variability conditions, the Current function resulted in a mean designation time of 13.15 s per target. This time was reduced to a mean of 11.91 s when the Alternative function was used, resulting in a 9.4% decrease in designation time. An ANOVA revealed this to be a significant main effect ($F(1,15) = 11.34, p < .0042$). Delay variability, averaged across gain function, also appeared to impact designation time (see Figure 5-5b). The variable delay condition elicited a mean designation time of 13.03 s, and the fixed delay condition yielded a mean designation time of 12.03 s. The ANOVA, however, revealed that this effect of delay variability did not achieve statistical significance at $\alpha = .05$ ($F(1,15) = 4.26, p < .0567$). No interaction was found to exist between gain function and delay variability.

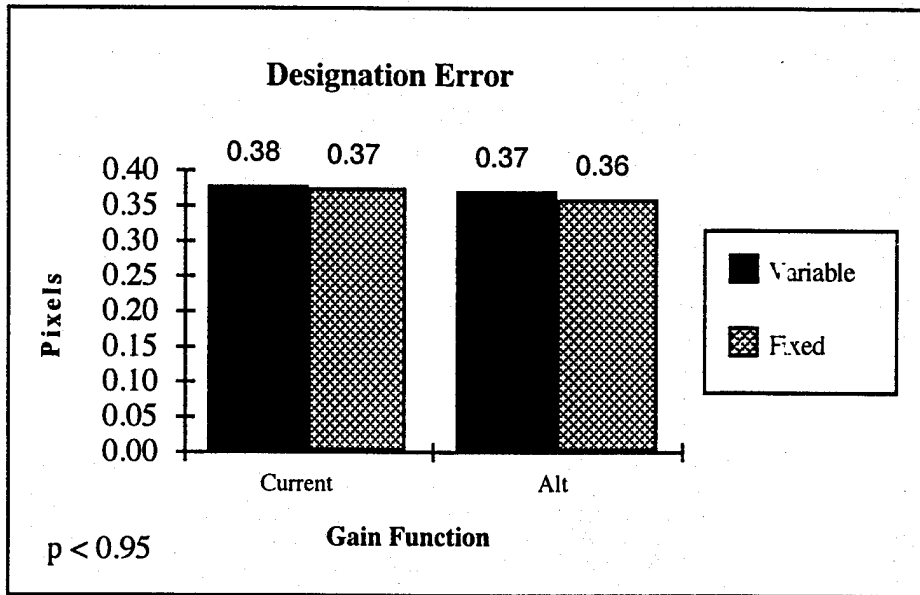

Figure 5-2. Mean effects of gain function on designation error for each level of delay variability.

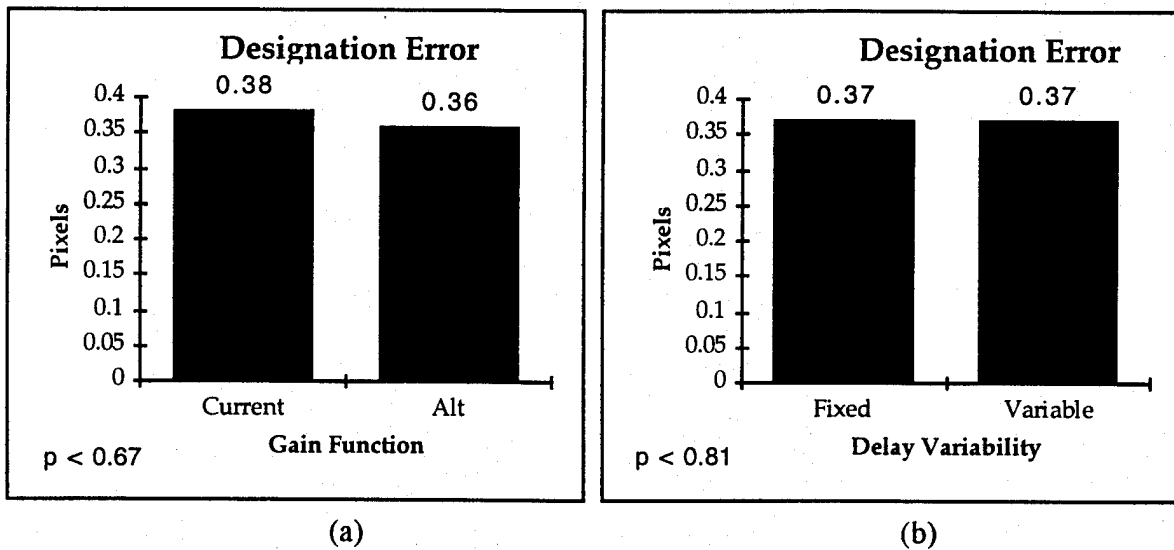

Figure 5-3. Mean effects of gain function (a) and delay variability (b) on designation error. Effects of gain function are collapsed across delay variability conditions (a), and effects of delay variability are collapsed across gain functions (b).

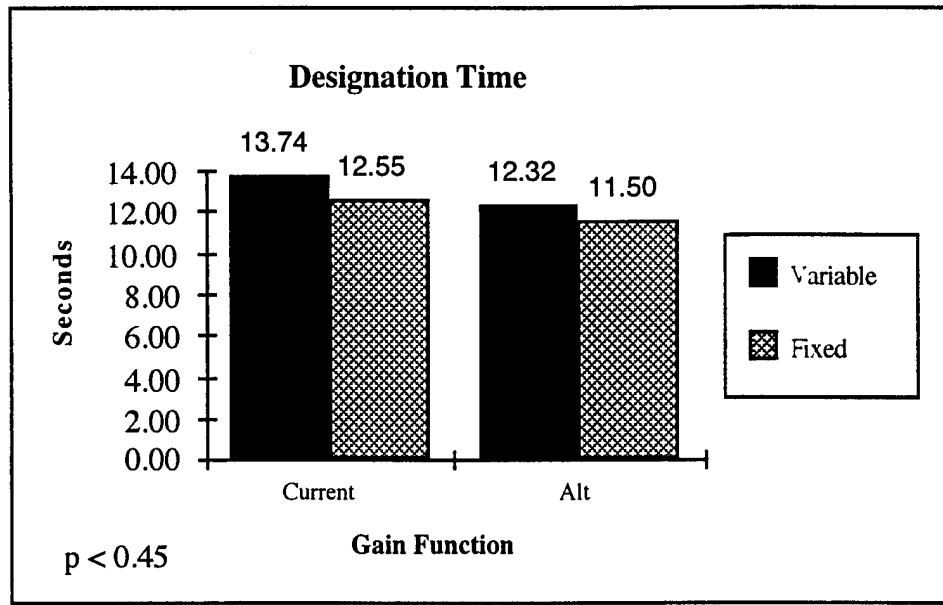

Figure 5-4. Mean effects of gain function on designation time (per target) for each level of delay variability.

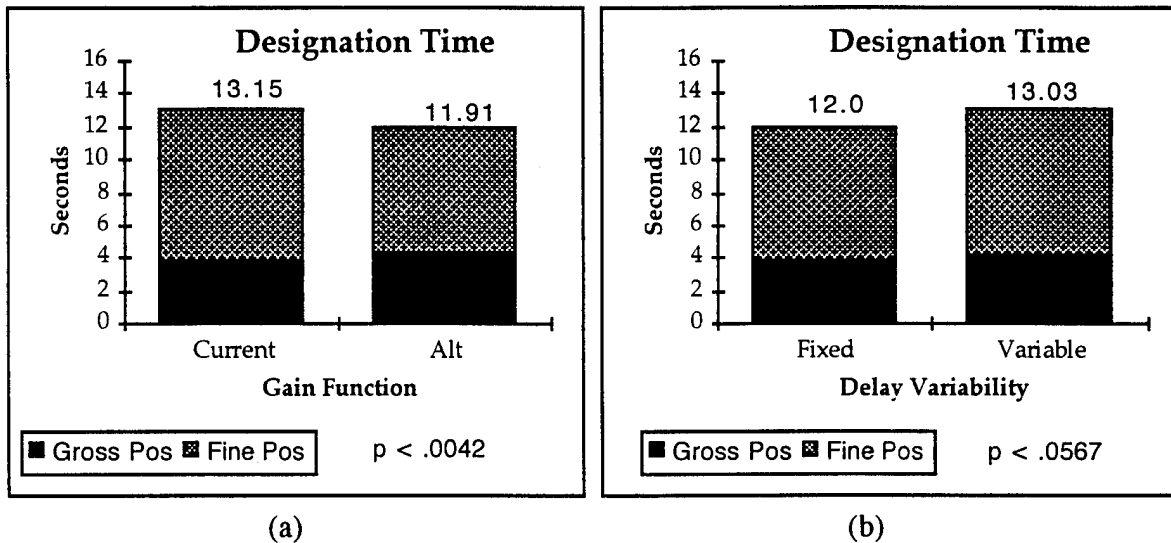

Figure 5-5. Mean effects of gain function (a) and delay variability (b) on designation time. Relative contributions of both gross and fine positioning time are shown. Effects of gain function are collapsed across delay variability conditions (a), and effects of delay variability are collapsed across gain functions (b).

Gross Positioning Time: To more closely examine the effects of gain function and delay variability, designation time was separated into gross positioning and fine positioning components (see Figure 5-5). Gross positioning time was found to take approximately 0.50 s longer with the Alternative function (4.33 s) than with the Current function (3.83 s). The ANOVA revealed this to be a significant main effect ($F(1,15) = 14.57, p < .0017$). There was no significant effect of processing delay variability on gross positioning time.

Fine Positioning Time: Fine positioning time, conversely, was found to be longer with the Current gain function than with the Alternative function ($F(1,15) = 38.26, p < .0001$). As shown in Figure 5-5, the Current function resulted in a mean fine positioning time of 9.31 s, whereas the Alternative function elicited a mean time of 7.58 s, resulting in a 1.73 s reduction in fine positioning time. This finding suggests that there is a trade-off associated with each gain function with regard to gross and fine positioning performance. The Current function resulted in slightly faster gross positioning at the cost of slower fine positioning, whereas the Alternative function sacrificed a slight amount of gross positioning speed while eliciting faster fine positioning. The net effect of gain function upon designation time was a 1.24 s speed advantage of the Alternative gain function over the Current function. As with gross positioning time, fine positioning time was not significantly impacted by processing delay variability.

Overshoots: Figure 5-6 shows the mean number of overshoots (per target) for each function under each delay variability condition. Like designation time, the number of overshoots occurring on a given designation event was found to differ across gain functions. Averaged across delay variability conditions, as shown in Figure 5-7a, the Current function resulted in a mean of 3.38 overshoots, compared to a mean of 2.48 overshoots elicited by the Alternative function. The ANOVA revealed this to be a significant main effect of gain function ($F(1,15) = 48.53, p < .0001$). The number of overshoots was not influenced by delay variability (see Figure 5-7b).

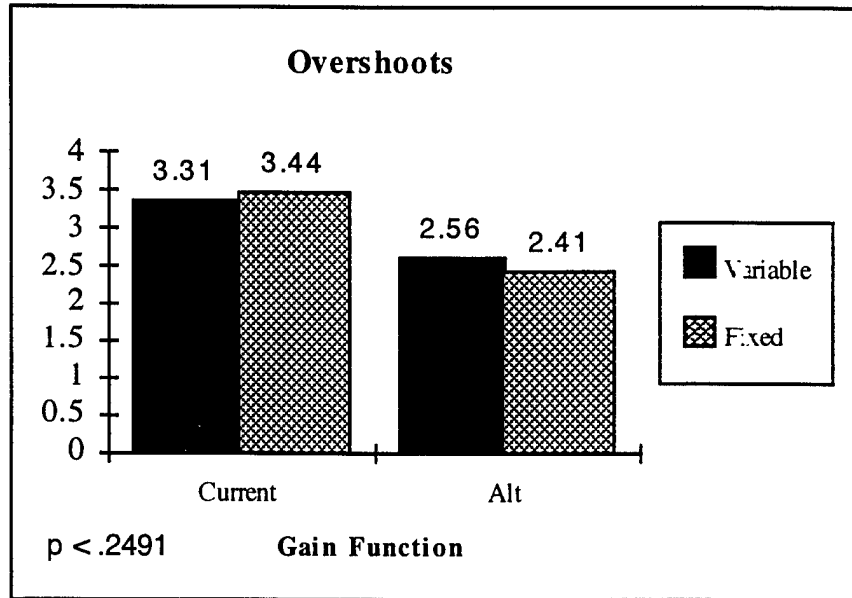

Figure 5-6. Mean effects of gain function on overshoots for each level of delay variability.

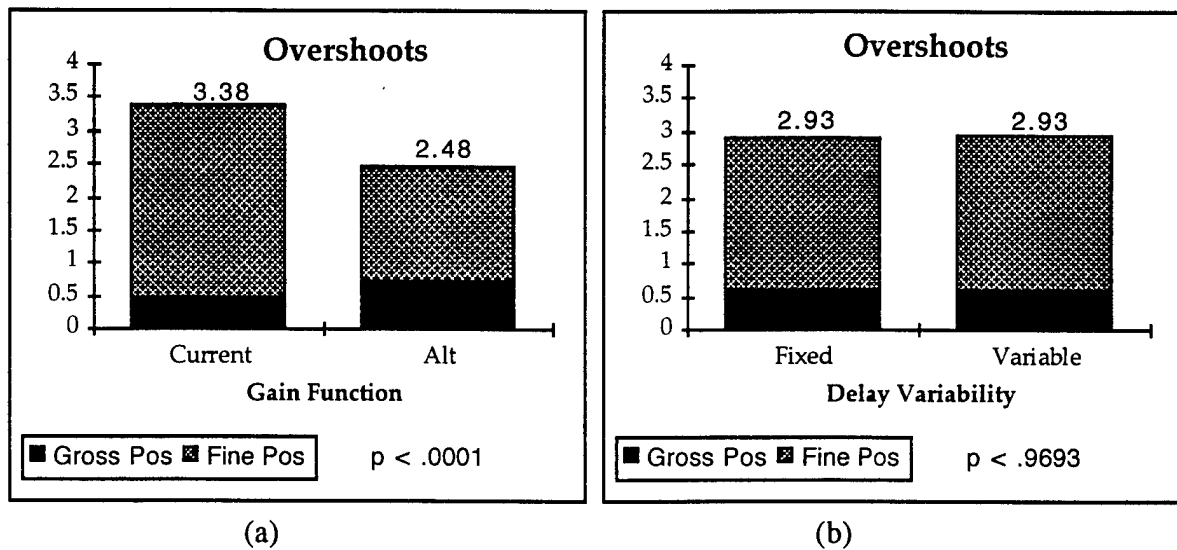

Figure 5-7. Mean effects of gain function (a) and delay variability (b) on overshoots. Relative contributions of both gross and fine positioning overshoots are shown. Effects of gain function are collapsed across delay variability conditions (a), and effects of delay variability are collapsed across gain functions (b).

Gross Positioning Overshoots: To examine the effect of gain function more closely, gross positioning overshoots and fine positioning overshoots were assessed independently. The relative contributions of each are also shown in Figure 5-7. Gain function was found to significantly impact the number of gross positioning overshoots that occurred for each designation event, with the Alternative gain function eliciting 0.74 overshoots, compared to 0.48 overshoots with the Current function ($F(1,15) = 15.15, p < .0014$). Delay variability was not found to significantly impact the number of gross positioning overshoots.

Fine Positioning Overshoots: An opposite effect of gain function on overshoots was seen with regard to fine positioning. As depicted in Figure 5-7, the Alternative gain function was found to elicit significantly *fewer* fine positioning overshoots (1.74) than the Current function (2.89) across delay variability conditions ($F(1,15) = 100.10, p < .0001$). This suggests a degree of trade-off between gross and fine positioning performance, with the Alternative function resulting in a slightly higher number of gross positioning overshoots but also resulting in significantly fewer fine positioning overshoots. The net result is a significantly lower number of total overshoots elicited by the Alternative gain function.

Subjective Evaluations: After completing Experiment 2, subjects were asked to respond to a series of questions designed to assess subjective evaluations of gross positioning performance under the various experimental conditions. These questions addressed the effect of gain function as well as the effect of processing delay variability.

Gain Function Effectiveness: One series of questions addressed the effect of gain function on subjects' ability to perform gross positioning, a significant component of the designation task in Experiment 2. The questions asked and the subjects' mean ratings of difficulty are listed in Table 5-1. Responses indicated that subjects felt that both accuracy and speed of gross positioning were slightly easier with the Alternative gain function. However, both gain functions were rated near "average" along these dimensions.

Table 5-1. Subjective Evaluations of Effect of Gain Functions on Gross Cursor Positioning

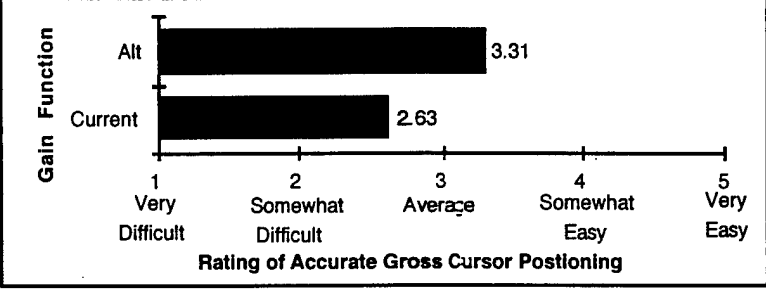
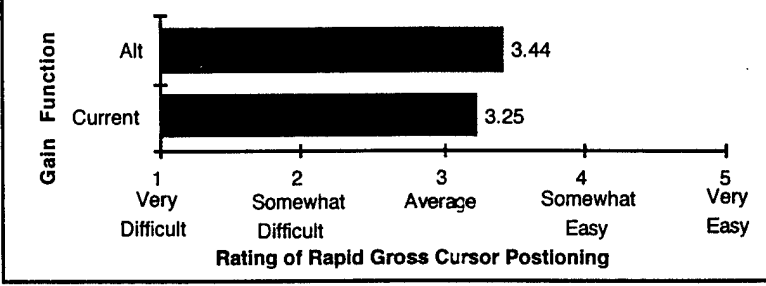
Question	Mean Ratings						
<p>1) Rate the level of difficulty associated with <i>accurately</i> moving the cursor across large distances (i.e., performing gross positioning).</p>	 <table border="1"> <caption>Rating of Accurate Gross Cursor Positioning</caption> <thead> <tr> <th>Gain Function</th> <th>Mean Rating</th> </tr> </thead> <tbody> <tr> <td>Alt</td> <td>3.31</td> </tr> <tr> <td>Current</td> <td>2.63</td> </tr> </tbody> </table>	Gain Function	Mean Rating	Alt	3.31	Current	2.63
Gain Function	Mean Rating						
Alt	3.31						
Current	2.63						
<p>2) Rate the level of difficulty associated with <i>quickly</i> moving the cursor across large distances (i.e., performing gross positioning).</p>	 <table border="1"> <caption>Rating of Rapid Gross Cursor Positioning</caption> <thead> <tr> <th>Gain Function</th> <th>Mean Rating</th> </tr> </thead> <tbody> <tr> <td>Alt</td> <td>3.44</td> </tr> <tr> <td>Current</td> <td>3.25</td> </tr> </tbody> </table>	Gain Function	Mean Rating	Alt	3.44	Current	3.25
Gain Function	Mean Rating						
Alt	3.44						
Current	3.25						

Delay Variability: With regard to the effect of processing delay variability, the questions asked and a summary of subject responses are listed in Table 5-2. Nearly all of the subjects (94%) responded that they perceived a difference in task difficulty between the variable and fixed delay conditions. On average, subjects rated cursor positioning in the fixed delay condition as an “average” level of difficulty, while rating the variable delay condition as “somewhat difficult.”

Overall Subjective Evaluations: After completing both Experiments 1 and 2, a final pair of questions addressed the overall effect of gain function across both the navigational SAR update task and the GATS-like targeting task (i.e., the overall effectiveness for performing fine as well as gross positioning). The questions and a summary of subject responses are shown in Table 5-3. Overall, subjects rated the Current gain function as being between “somewhat ineffective” and “average” in terms of effectiveness for designating aimpoints. The Alternative gain function, however, was rated as being “somewhat effective.” Similarly, when subjects were asked to state an overall preference for one gain function, the consensus was unanimously in favor of the Alternative gain function.

Table 5-2. Subjective Evaluations of Effect of Delay Variability

Question	Summary of Responses						
<p>1) Did you notice a difference in task difficulty between the fixed and variable system delay conditions?</p>	 <p>A horizontal bar chart with the x-axis labeled '% Responding Yes' ranging from 0% to 100% in 20% increments. A single black bar extends to the 94% mark. The y-axis is labeled 'yes'.</p> <table border="1"> <tr> <td>Response</td> <td>Percentage</td> </tr> <tr> <td>yes</td> <td>94%</td> </tr> </table>	Response	Percentage	yes	94%		
Response	Percentage						
yes	94%						
<p>2) Rate the level of difficulty associated with cursor positioning for each of the system delay conditions.</p>	 <p>A horizontal bar chart with the x-axis labeled 'Rating of Cursor Positioning' ranging from 1 to 5. The y-axis is labeled 'Gain Function' with categories 'Fixed' and 'Variable'. The x-axis labels are: 1 Very Difficult, 2 Somewhat Difficult, 3 Average, 4 Somewhat Easy, 5 Very Easy. The 'Fixed' bar has a value of 3.13 and the 'Variable' bar has a value of 2.25.</p> <table border="1"> <tr> <th>Gain Function</th> <th>Rating</th> </tr> <tr> <td>Fixed</td> <td>3.13</td> </tr> <tr> <td>Variable</td> <td>2.25</td> </tr> </table>	Gain Function	Rating	Fixed	3.13	Variable	2.25
Gain Function	Rating						
Fixed	3.13						
Variable	2.25						

Table 5-3. Overall Subjective Evaluations of Gain Functions

Question	Summary of Responses						
<p>1) Please rate the overall effectiveness of each cursor system gain function for designating aimpoints.</p>	 <table border="1"> <caption>Rating of Overall Cursor Positioning</caption> <thead> <tr> <th>Gain Function</th> <th>Rating</th> </tr> </thead> <tbody> <tr> <td>Alt</td> <td>4.13</td> </tr> <tr> <td>Current</td> <td>2.5</td> </tr> </tbody> </table>	Gain Function	Rating	Alt	4.13	Current	2.5
Gain Function	Rating						
Alt	4.13						
Current	2.5						
<p>2) Overall, which gain function did you prefer for performing SAR navigational updates and targeting?</p>	 <table border="1"> <caption>% of Responses</caption> <thead> <tr> <th>Gain Function</th> <th>% of Responses</th> </tr> </thead> <tbody> <tr> <td>Alt</td> <td>100%</td> </tr> <tr> <td>Current</td> <td>0%</td> </tr> </tbody> </table>	Gain Function	% of Responses	Alt	100%	Current	0%
Gain Function	% of Responses						
Alt	100%						
Current	0%						

Discussion

Effect of Gain Function on Designation Error: As in Experiment 1, gain function did not impact the accuracy of designation. Designation error averaged approximately 0.37 pixels per designation event, which is very near the 0.38 pixel mean designation error observed for the cued target pixels in Experiment 1. This finding again suggests that subjects placed emphasis on accuracy over speed in conducting the GATS-like targeting task. Therefore, differences in performance due to gain function were seen in the time it took to perform with such accuracy as well as the number of overshoots that occurred.

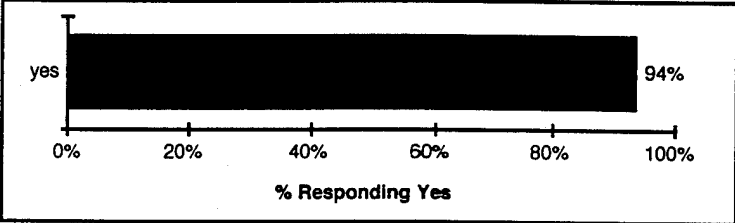
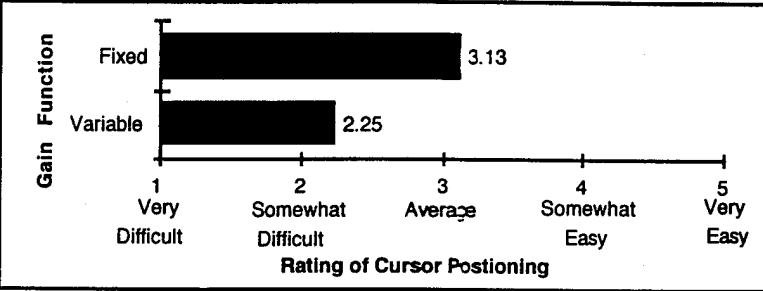
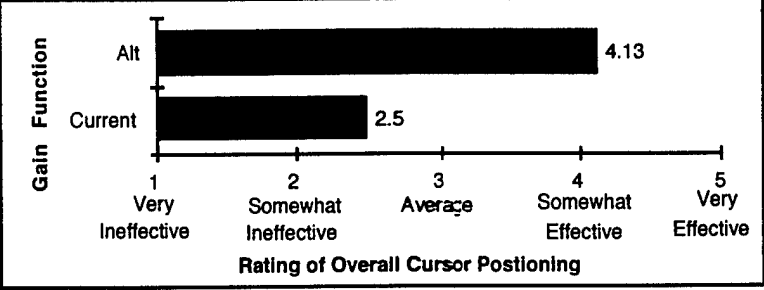
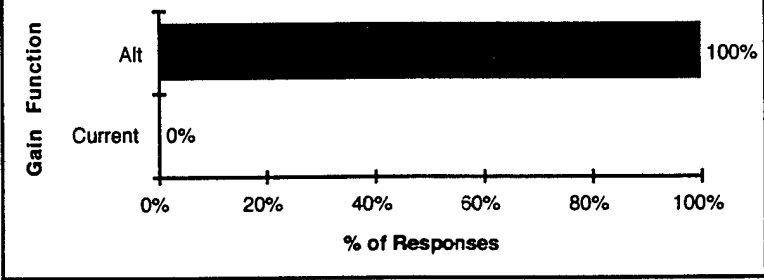
Effect of Gain Function on Designation Time: Examining gross and fine positioning time separately revealed the fact that both the Current and Alternative gain functions exhibit a trade-off between gross and fine positioning performance (see Figure 5-5a). The Alternative gain function elicited slightly longer gross positioning times while also resulting in shorter fine positioning times. Overall, total designation time was found to be significantly shorter with the Alternative gain function. As was seen in Experiment 1, this trade-off between gross and fine positioning time can be attributed directly to a trade-off in the number of gross and fine positioning overshoots.

Effect of Gain Function on Overshoots: The effect of gain function on overshoots closely resembles the effect on designation time. That is, a trade-off was exhibited between gross and fine positioning performance. This relationship is not surprising given that the number of overshoots and their subsequent correction directly impact the time it takes to accurately position the cursor. Use of the Current gain function resulted in more fine positioning overshoots but fewer gross positioning overshoots than the Alternative function. The fact that the Alternative function produced fewer fine positioning overshoots supports the finding in Experiment 1 that the lower slope associated with small input forces allows a greater degree of fine positioning control.

The increase in fine positioning control, however, seems to be at the expense of some gross positioning control. That is, as fine positioning control was enhanced with the Alternative gain function, gross positioning control became slightly degraded. Two interacting factors are thought to produce this effect. First, it is possible that the maximum cursor velocity resulting from the Alternative gain function (i.e., 250 pix/s) may have been too fast, and thus harder to control, than the maximum velocity resulting from the Current function (i.e., 191 pix/s). It is reasonable to assume that, although the faster gross positioning movement

associated with the Alternative gain function allowed faster slewing over large distances, it was also more difficult to predict in terms of where the cursor would stop after input ceased. This may have served as one cause of the slight degradation in gross positioning performance with the Alternative function.

A related explanation for the performance trade-off may lie in the fact that the functional range of gross positioning control was reduced with the Alternative gain function, just as the functional range of fine positioning control was increased. That is, the Current gain function, being linear, doubles cursor velocity from 95.5 pix/s to 191 pix/s over the upper 50% of the force input range (1.75 to 3.0 lb). The Alternative function, however, is asymmetric and thus, doubles its cursor velocity over the upper 34% of the force input range (2.15 to 3.0 lb).

A gross vs. fine positioning performance trade-off such as that observed in the current study would likely be inherent to any asymmetrical system gain function. As the slope of the function associated with small input forces is lowered to enhance fine positioning control, the slope associated with gross positioning must be *increased* to achieve the same maximum cursor velocity at the highest input force. This increased slope associated with higher input forces may frequently result in a degradation of gross positioning control. Thus, performance must be evaluated in terms of *overall* cursor control and designation performance. As shown in Figure 5-7, the current study demonstrated that the Alternative gain function elicited better overall performance with regard to overshoots due to the fact that the slight increase in gross positioning overshoots was outweighed by a much larger *decrease* in fine positioning overshoots.

Processing Delay Variability: Overall, delay variability had little impact on performance. With the exception of a trend toward shorter designation time with the fixed delay, virtually no difference in the number of overshoots or amount of designation error was observed between the fixed processing delay and variable processing delay conditions.

Although implementing a fixed processing delay condition failed to produce significant improvements in performance, operators seemed to prefer the fixed processing delay over the variable processing delay, associating it with easier cursor positioning. Based on the minimal differences observed in the performance data, it is possible that the subjective preference for the fixed processing delay may have been ~~due~~ to an aesthetic preference more than any true advantage in functionality. When moving the cursor rapidly across the screen, the variable processing delay resulted in an erratic movement that many subjects referred to

as "jumpy." The fixed processing delay, conversely, resulted in a smooth constant motion of the cursor. It is apparent that subjects perceived this noticeable difference in smoothness of cursor motion to impact their performance to a greater degree than it actually did.

Reduction of Processing Delay: Though it would require more than a simple software upgrade, it is likely that a much greater increase in performance (i.e., lower designation times) could be achieved if the *length* of the processing delay were reduced. The best evidence for this was shown by Basile (1990), described in the Introduction. Basile, examining performance across a range of fixed processing delays, showed significant increases in cursor positioning time associated with increasing processing delays. Using Basile's data, one can extrapolate the *decrease* in designation times that might be observed in the B-2 if the processing delay were reduced. For purposes of this extrapolation, designation times from the fixed processing delay condition in the current study should be used. The validity of this extrapolation, however, must be considered with caution due to the fact that Basile's cursor was controlled by a trackmarble rather than an isometric controller used in the B-2.

The linear relationship between length of processing delay and cursor positioning time can be seen in Figure 5-8. Here, Basile's data, obtained under a fixed delay conditions ranging from 75 ms to 400 ms, is fit with a linear regression. The resulting line has an intercept of 2.837 ($p < 1.98E-09$) and a slope of 7.327 ($p < 2.46E-08$). From this regression, it is possible to estimate the positioning time associated with a delay of 250 ms (i.e., the mean processing delay in the B-2 system). A value of 4.669 s was obtained for a 250 ms delay using the following equation:

$$\begin{aligned} \text{(Positioning time)} &= (\text{Slope} \times \text{Delay}) + (\text{Intercept}) \\ &= (7.327 \times 0.250 \text{ s}) + 2.837 \text{ s} \\ &= 4.669 \text{ s} \end{aligned}$$

It directly follows that the positioning time associated with a delay of 75 ms is 72.5% of that associated with a system with a delay of 250 ms. Assuming that an equivalent decrease in designation time could be obtained if the 250 ms processing delay in the B-2 cursor system were reduced to 75 ms, one can easily estimate performance increase that might be achieved. Table 5-4 shows the mean gross positioning time, fine positioning time, and total designation time elicited by the Current and Alternative gain functions under the 250 ms fixed processing delay condition, as well as their projected corresponding times if a 75 ms fixed system delay

could be achieved. The 75 ms entries in Table 5-4 are calculated by multiplying the mean gross, fine and total cursor positioning times by 0.725. Based on this extrapolation, one could expect an additional 27.5% decrease in designation time if the mean processing delay could be reduced from 250 ms to 75 ms.

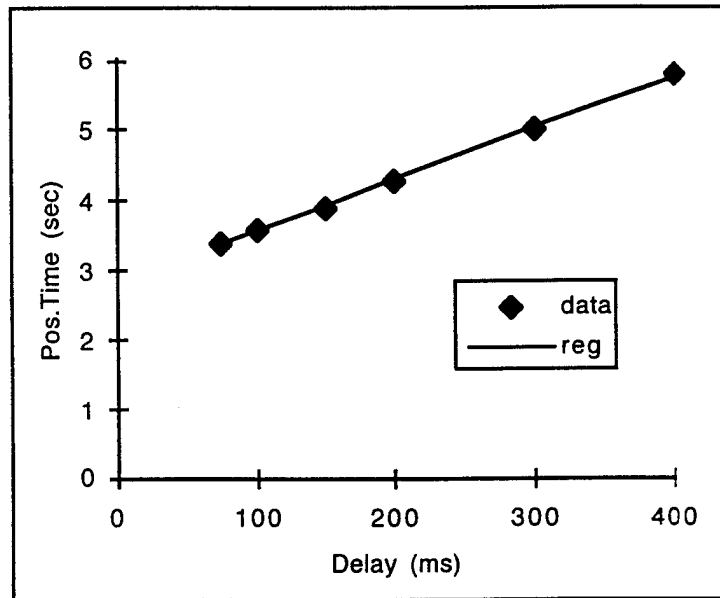

Figure 5-8. Linear regression fit to data presented in Basile (1990).

Table 5-4. Extrapolation from Basile (1990) to Current Data

Gain Function	Delay	Positioning Time (sec)		
		Gross	Fine	Total
Current	250 ms	3.65	8.90	12.55
Current	75 ms	2.65*	6.45*	9.10*
Alternative	250 ms	4.24	7.26	11.50
Alternative	75 ms	3.07*	5.26*	8.34*

* Predicted values based on extrapolation

One could also expect to see a higher degree of operator acceptance associated with a shorter processing delay. On average, Basile's subjects were able to "perceive" a processing delay of 120 ms and found a delay of 200 ms "annoying." The processing delay currently in the B-2 exceeds both of these thresholds.

SECTION VI

Conclusion and Recommendations

Conclusion

Both performance and subjective data from Experiments 1 and 2 indicate that the Alternative gain function will result in improved cursor positioning performance by mission commanders in the B-2. Experiment 1 indicated that the improved fine positioning associated with the Alternative function can be attributed to the lower gain (i.e., a lower slope) associated with small input forces. By providing operators with a greater dynamic range for the forces associated with fine positioning, the Alternative function permits operators to exert a wider range of short-duration forces, thereby facilitating fine cursor positioning control. It is theorized that the benefit of this lower gain will be even greater in a fully operational environment. A number of crew members participating in the study commented that the B-2 offers a somewhat turbulent ride, and that the operator experiences vibration and jarring in the cockpit. Under these conditions, gain functions such as the Current function would be more susceptible to inadvertent actuation and poor fine control. A less sensitive fine positioning region, such as that offered by the Alternative gain function, would be less affected by input force irregularities caused by turbulence.

The improvement in cursor positioning performance with the Alternative function was shown to be in the form of fewer incidents of overshooting the "golden pixel" as well as shorter designation times. Although the Alternative function was not shown to increase the accuracy of designation, Experiment 1 revealed that, when the target pixel is unambiguous (i.e., when imagery interpretation error is removed), the mean designation error achievable with the Alternative as well as the Current gain function (0.38 pixels) is well within the stated accuracy criterion of 1.0 pixel.

Experiment 2 used a semi-operational GATS task that required both gross and fine positioning movements to achieve accurate designation. This approach provided a broader characterization of cursor positioning and enabled separate analyses of gross and fine positioning performance. Results of Experiment 2 demonstrated a gross/fine positioning performance trade-off within the cursor system gain functions that favored the Alternative gain function for overall cursor positioning. The Alternative function resulted in shorter designation times and fewer overshoots, indicating that it may offer increased crew member performance in an operational GATS environment.

With respect to the variability in processing delay, the fact that subjects perceived the fixed processing delay condition to facilitate cursor positioning offers some evidence that the reduction or elimination of this variability may improve cursor positioning performance in the aircraft. Performance data, however, did not strongly support this hypothesis. Although a trend toward faster designation time was observed in the fixed processing delay condition, this difference was not statistically significant. Similarly, neither overshoots nor designation error were found to be impacted by delay variability. Thus, the current investigation revealed no strong evidence that a modification to reduce the *variability* in the processing delay would be warranted. Based on previous research, however, it is likely that the reduction of the delay itself would produce a significant increase in performance.

In evaluating the potential benefit of implementing the Alternative gain function, one must consider the anticipated increase in performance (i.e., a 14% reduction in SAR navigational update designation time and a 9% reduction in GATS target designation time). In addition, one should also consider the overwhelming operator preference for the Alternative gain function. In both the SAR navigational update and GATS-like targeting tasks, subjects consistently rated cursor positioning with the Alternative function as being easier than with the Current function. Although no measures of workload were collected, this subjective rating suggests that there may be a difference between functions in terms of their impact on operator workload. If so, it is possible that the *performance* advantage associated with the Alternative function may become greater under high-workload conditions.

Recommendations

As discussed in the Introduction, cursor positioning and designation performance can be impacted by a number of system variables, including the cursor control mechanism, the system gain function, the length of processing delay, the variability of the processing delay and the physical structure of the cursor itself. Because performance is driven by so many variables, it is unlikely that independent manipulation of any single component will result in an optimal operator/system performance. To obtain a system that is truly optimized for cursor positioning and designation performance, each component of the system must be examined and optimized.

Investigations of individual cursor system components, however, can result in modifications that will significantly increase operator performance. Considering the observed increases in

crew member performance and acceptance associated with the Alternative cursor system gain function, it is recommended that the Alternative function described here be considered for implementation in the aircraft. It is anticipated that such a modification would produce performance increases in an operational environment similar to those seen experimentally. In addition, it is suggested that the current results may be generalizable to any slewing task requiring both gross and fine positioning of an isometrically-controlled cursor. The sigmoidal shape of the Alternative gain function increases the range of fine positioning control while maintaining the capacity for rapid cursor movement, thereby increasing overall slewing performance. This advantage over a simple linear gain function can be expected to exist across a wide range of isometrically-controlled cursor systems.

It is not, however, recommended that significant effort be taken to reduce the variability in cursor processing delay, as such a reduction was shown to elicit only minimal improvements in performance. Rather, it is suggested that the possibility of reducing the processing delay be investigated. If, in the future, a reduction in the processing delay were achieved, the sigmoidal gain function described here could be easily scaled to account for the increased degree of cursor movement predictability associated with the reduction in delay.

BIBLIOGRAPHY

B-2 Combined Test Force, Service Report, Material Improvement Project: ASSCCA20198. Radar Cursor Controller Slew, 1992.

Basile, S. D., Cursor Positioning Performance as a Function of Delay Between Trackmarble Movement and Cursor Motion, NUSC Technical Report 8757, Naval Underwater Systems Center, 1990.

Gibbs, C. B., Controller Design: Interactions of Controlling Limbs, Time-Lags and Gains in Positional and Velocity Systems. Ergonomics, 5, 385-402, 1962.

Hammerton, M., An Investigation into the Optimal Gain of a Velocity Control System. Ergonomics, 5, 539-543, 1962.

Hammerton, M., and Tickner, A. H., An Investigation into the Comparative Suitability of Forearm, Hand and Thumb Controls on Acquisition Tasks. Ergonomics, 9, 125-130, 1966.

Irvin, J. G., Doyal, J. A., Sharp, E.D., LaSalvia, J.M., Experimental Evaluation of Cursors for B-2 Synthetic Aperture Radar Application. AL/CF-TR-1994-0020. Armstrong Laboratory, Human Systems Division, Air Force Systems Command, 1994.

Legge, G. E., Spatial Frequency Masking in Human Vision: Binocular Interactions. Journal of the Optical Society of America, 69, 838-847, 1979.

Nachmias, J., On the Psychometric Function for Contrast Detection, Vision Research, 21, 215-223, 1981.

Quick, R. F., Jr., A Vector-Magnitude Model of Contrast Detection. Kybernetik, 16, 65-67, 1974.

Rauch, S., Determination of a Gain-Function Relating Control Force to Cursor Velocity. Proceedings of the Human Factors Society 32nd Annual Meeting, p. 121-125, 1988.

Watson, A. B. and Nachmias, J., Summation of Asynchronous ratings, Vision Research, 20, 91-94, 1980.

LIST OF SYMBOLS, ABBREVIATIONS AND ACRONYMS

ACC	Air Combat Command
AL/CFHI	Armstrong Laboratory, Crew Systems Directorate, Human Engineering Division, Crew Systems Integration Branch
ASC/YSD	Aeronautical Systems Center, B-2 Engineering, Manufacturing and Development
CCP	Cursor Control Panel
CEF	Cockpit Evaluation Facility
CTF	Combined Test Force
DPU	Display Processing Unit
DRLMS	Digital Radar Landmass Simulator
EVS	Electro-optical Viewing System
FLIR	Forward Looking Infrared
FMCP	Flight Management Control Processor
GATS	GPS-Aided Targeting System
GPS	Global Positioning System
MC	Mission Commander
NAV	Navigator
OSO	Offensive Systems Officer
RFP	Radar Fix Point
RN	Radar Navigator
SAIC	Science Applications International Corporation
SAR	Synthetic Aperture Radar
SEDATA	Systems Engineering Design and Technical Analysis
SG	Silicon Graphics
SIDEF	Systems Integration Design and Evaluation Facility
USAF	United States Air Force
USGS	United States Geological Survey
WSO	Weapon Systems Officer

APPENDIX A

DEVELOPMENT OF ALTERNATIVE GAIN FUNCTION

DEVELOPMENT OF ALTERNATIVE GAIN FUNCTION

Approach

In developing the Alternative gain function tested here, various cursor gain functions were evaluated empirically. These included linear, bilinear, exponential, quadratic, and sigmoidal functional forms. A population of critical points in the various cursor gain functions were identified as described below. The process involved the use of subject matter experts, part-task data collection, performance evaluation with rapid prototyping tools and techniques, and subjective evaluations of the various cursor gain function classes with various combinations of critical points implemented.

Task Requirements.

The first step in identifying a gain function that would improve performance was to understand the requirements of B-2 radar-embedded cursor positioning tasks. The first task identified was the SAR navigational update task, which is currently the primary cursor positioning task performed with the radar-embedded cursor. Because of the relative accuracy of the B-2 navigational system, this task typically requires a cursor movement of less than seventeen pixels to reach the target, or "golden," pixel. Thus, the SAR navigational update task can be considered a fine positioning task in which gross movements of the cursor are generally unnecessary. This suggested that the alternative gain function should be designed to allow a high level of fine positioning control.

A second radar-embedded cursor positioning task is the GATS targeting task. Although the GATS system is not yet fielded, target designation will require accurate cursor positioning performance. In most cases, this task will require only fine positioning of the cursor. However, in certain multiple targeting conditions and in the case of designating targets of opportunity, slewing across large distances will be required. In addition, anticipated scenarios will require multiple designations within a limited time period, thereby requiring not only accurate, but also rapid designation. Thus, characteristics of the GATS target designation task suggested that the alternative gain function must retain the ability to move the cursor rapidly across the display (i.e., allow accurate, rapid gross positioning).

Gain Function Characterization

Once the requirements of the task were understood, characteristics of an appropriate gain function to meet these requirements were outlined. Based on observations of operator performance with the Current gain function, it was apparent that the gain function must be less sensitive at the low end (i.e., less sensitive to low force inputs). One characteristic of the desired gain function was that the sensitivity be low enough to result in single-pixel movements when desired. Another characteristic was that it should allow controlled positioning over short distances (i.e., between 1 and 20 pixels) in order to adequately facilitate fine positioning. Finally, to meet requirements imposed by the GATS targeting task, the gain function must be more sensitive to higher force inputs to allow rapid gross positioning when desired.

With a linear gain function such as the function currently implemented, all three of these characteristics can not be satisfied simultaneously. With the current slope of the linear function, adequate fine positioning control is not achieved. If the slope were to be reduced, however, the resulting maximum cursor velocity would be too slow to allow sufficiently-rapid gross positioning. Thus, it became apparent that the gain function must be non-linear in order to facilitate both gross and fine cursor positioning. As a result of coordination with the B-2 SPO and AL/CFHI, an up-front decision was made to retain the breakout force (0.50 lb) and maximum force (3.0 lb) currently used in the cursor system, and to vary only the shape and magnitude of the cursor velocity curve between these points. Using rapid prototyping and subjective evaluation of various gain functions for performing cursor positioning tasks, individual points on a cursor velocity curve were selected for evaluation, and optimal values were determined. This process is described below.

Identification of Critical Points Defining the Gain Function

Gross Cursor Positioning: The first step in defining an improved gain function was to determine an acceptable magnitude of maximum cursor velocity. This value would help define the gain associated with rapid cursor movement over long distances (i.e., gross positioning). Rauch (1988) investigated this issue in the F-14D and suggested that the lowest gain function examined, which resulted in a maximum cursor velocity of approximately 486 pix/s, may not have been optimal. He concluded that a lower gain function may possibly result in better designation performance. Conversations with a number of radar operators, including one B-2 crew member, indicated that a cursor velocity of 486 pix/s would be much

higher than necessary. These conversations resulted in a recommended maximum cursor velocity of between 200 and 350 pix/s. This recommendation underwent an evaluation using the Prototyping and Evaluation Station (P&ES) resident at Armstrong Laboratory. A full description of the P&ES is presented in Section IV.

For this evaluation, a computer program was developed that allowed an operator to perform a simple gross positioning task with the B-2 cursor control panel and to vary the maximum cursor velocity between 200 and 350 pix/s in increments of 25 pix/s. Like the Current B-2 system, the evaluation system had a breakout force of 0.50 lb and attained maximum cursor velocity at 3.0 lb. The system was driven by a simple linear gain function, the slope of which increased as higher maximum cursor velocities were entered. The cursor positioning task simply required operators to slew the cursor a minimum distance of 100 pixels and position it within a box 30 x 30 pixels square as quickly as possible. Between slewing events, subjects could increase or decrease the maximum cursor velocity. Four individuals performed this evaluation. These evaluators had knowledge of the cursor system and were instructed to attain maximum cursor velocity (i.e., ≥ 3.0 lb input force) when performing the task. After performing a number of slewing events, three of the four evaluators chose 250 pix/s as being the optimum cursor velocity. With the exception of one individual who preferred a maximum velocity of 300 pix/s, evaluators felt that they had trouble controlling the cursor when maximum velocity exceeded 250 pix/s. On the basis of this subjective evaluation, 250 pix/s was chosen as the maximum cursor velocity for the proposed alternative gain function. Although this maximum velocity was much slower than those examined in Rauch's study of the F-14D cursor system, it was approximately 31% faster than the maximum velocity available with the Current B-2 cursor system gain function (191 pix/s).

Fine Cursor Positioning: Because crew member complaints were centered around an inability to perform fine cursor positioning, the attempt to develop an improved gain function focused on determining appropriate cursor velocities to correspond with *fine positioning* (i.e., low force) control inputs. In particular, researchers sought to identify a force/velocity relationship that would allow 1) controlled cursor movement over short distances (i.e., controlled fine positioning), and 2) the ability to move the cursor one pixel at a time. To aid in identifying such a relationship, a simple fine positioning task was developed using the P&ES. This task required subjects to slew the cursor a random distance between four and seventeen pixels, and to designate a single highlighted pixel as quickly as possible. Based on the evaluation described above, the gain function driving the cursor was set to achieve a maximum velocity of 250 pix/s. However, the computer program was modified to create a

bilinear gain function that changed slope at 1.75 lb. Bilinear gain functions such as this were used in the Rauch (1988) study to allow differential fine and gross positioning control (refer to Figure 1-2). By varying the desired cursor velocity attained at a force of 1.75 lb, operators manipulated the slope of both the fine positioning and gross positioning segments of the bilinear function. As the velocity at 1.75 lb was reduced, the slope of the fine positioning segment decreased. At the same time, however, the slope of the gross positioning segment increased by a corresponding amount in order to attain the maximum velocity of 250 pix/s at 3.0 lb of input force.

Again, four individuals within Armstrong Laboratory manipulated the cursor velocity between speeds of 25, 50 and 75 pix/s at 1.75 lb input force while performing a series of fine positioning trials. Subjectively, these evaluators unanimously preferred a cursor velocity of 50 pix/s for performing the fine positioning task. Thus, for the proposed alternative gain function, 50 pix/s was chosen as the cursor velocity to be attained at 1.75 lb of input force.

One-Pixel Movement: Once the preferred cursor velocities associated with 1.75 lb and 3.0 lb had been determined, the issue of one-pixel movement was addressed. In observing a number of operators performing fine positioning tasks, it became apparent that positioning requiring movement of only one pixel was accomplished using a "bumping" strategy. That is, operators typically used a light amount of constant pressure to approach the target pixel. However, they often stopped short by one or two pixels and had to lightly tap, or "bump," the cursor controller in order to move the cursor the short distance to the target pixel. With the gain function currently in the B-2, crew members have difficulty moving the cursor one pixel at a time even when using this bumping technique. Thus, researchers attempted to find a relationship between a typical bumping force and cursor velocity that would result in one-pixel movement. This was accomplished quite easily by examining force readouts from the cursor controller. Three right-handed male operators were observed as they attempted to move the cursor one pixel at a time. For each control input, the force and duration of the input were displayed on a separate computer monitor. During a typical "bump" of the cursor controller, the control mechanism was observed to be actuated for approximately 110 ms with a force of approximately 1.0 lb. Given this information, it was calculated that a cursor velocity of 10 pix/s at 1.0 lb (i.e., a typical bumping force) would result in a movement of one pixel ($10 \text{ pix/s} \times .110 \text{ s} = 1.1 \text{ pixel}$). Therefore, for the proposed alternative gain function, a cursor velocity of 10 pix/s at 1.0 lb was chosen.

Final Gain Function Definition

Only a function that was sigmoidal in nature could fulfill the requirements of fitting the various critical points in a smooth and continuous fashion. A general function fulfilling this requirement is the Quick equation (Quick, 1974). The base form of this equation is generally expressed as:

$$y = 1 - 2^{-\alpha x^{\beta}}$$

For our purposes y is expressed in pixels/second, x is force in pounds. α is a constant equal to 2.0, and the exponent β determines the slope (steepness) of the function. The use of this equation originates in the vision research literature with Quick (1974) and has been shown to provide an excellent description of frequency-of-seeing data in a variety of visual performance tasks (Nachmias, 1981; Watson & Nachmias, 1980; Legge, 1979; Graham, Robson & Nachmias, 1980). The Quick equation is scalable, displays shape invariance, and importantly, displays no discrete transitions in its first derivative. Based on control theory, this latter property is desirable in a motor control task, as discrete transitions in a control function (such as in a bilinear model, Figure 1-2) can degrade performance.

Four individuals tested various operative implementations of the basic Quick function and performed part-task evaluations of cursor gain functions using a variety of different parameters. The final variant of the Quick equation allowed for force axis and velocity axis scalability, lateral translation on the force axis, and base-variable logarithmic scalability of the force axis. The final cursor gain function selected for use in the experiment is shown in Figure 2-1. This function fulfills the critical point requirements established above for forces of 0.0, 0.5, 1.0, 1.75, and 3.0 pounds. This function also produced the best overall part task performance. A tabular version of this function is shown in Table A-1. This expression of the Quick equation was selected as the best estimate of an alternative gain function for use in the subsequent experimentation.

Table A-1. Look-up Table Defining Alternative Gain Function

Input Force (lb)	Cursor Velocity (pix/s)	Input Force (lb)	Cursor Velocity (pix/s)
0.00	0.00	1.55	37.48
0.05	0.00	1.60	41.82
0.10	0.00	1.65	46.66
0.15	0.00	1.70	52.02
0.20	0.00	1.75	57.97
0.25	0.00	1.80	64.53
0.30	0.00	1.85	71.75
0.35	0.00	1.90	79.65
0.40	0.00	1.95	88.25
0.45	0.00	2.00	97.56
0.50	3.11	2.05	107.57
0.55	3.46	2.10	118.22
0.60	3.87	2.15	129.47
0.65	4.33	2.20	141.18
0.70	4.84	2.25	153.24
0.75	5.43	2.30	165.45
0.80	6.10	2.35	177.59
0.85	6.85	2.40	189.44
0.90	7.71	2.45	200.67
0.95	8.68	2.50	211.04
1.00	9.78	2.55	220.34
1.05	11.04	2.60	228.34
1.10	12.47	2.65	234.92
1.15	14.10	2.70	240.07
1.20	15.95	2.75	243.88
1.25	18.06	2.80	246.50
1.30	20.46	2.85	248.16
1.35	23.19	2.90	249.13
1.40	26.30	2.95	249.63
1.45	29.84	3.00	250.00
1.50	33.72	3.05	250.00

APPENDIX B

B-2 RADAR CURSOR MECHANIZATION STUDY SUBJECT INSTRUCTIONS

B-2 RADAR CURSOR MECHANIZATION STUDY
SUBJECT INSTRUCTIONS

The objective of this study is to develop and evaluate a candidate gain function to drive the cursor system used for navigation and targeting in the B-2. It is expected that this gain function will elicit faster, more accurate designation of navigational fix points and targets than is being obtained with the current gain function.

You will be asked to perform a number of designation tasks in which you will use a thumb-actuated force controller to move a cursor on a screen. Once the cursor is in the desired position, you will "designate" by pulling a trigger on the control handle. The following are descriptions of the experimental conditions under which you will perform the designation task:

1) Operational SAR Update Task

In this condition, you will be presented with simulated SAR imagery on a multipurpose display unit (MDU). All imagery will be presented NORTH UP and contain representative aimpoints typical of those used in an operational bomber unit (e.g., storage tanks, bridges, buildings, etc.). Assume that the offensive avionics are operating normally and that a nominal buffer value exists. For each image presented, you will be asked to identify and designate an aimpoint as depicted on the Radar Fix Point (RFP) Graphic Card provided. The aimpoint contained on each photograph will be circled to indicate the target you are to designate for that particular trial. It is important that you designate aimpoints for each of the trials as accurately as possible based on the locations indicated on the RFP card.

The time at which a trial begins is under your control, thereby allowing you time to study the RFP card prior to initiating the trial. Trials are initiated by pressing the "image" button on the control handle. Once you initiate the trial however, you are asked to designate the aimpoint as quickly as possible. Once the aimpoint is designated (i.e., once you pull the trigger), the trial will end.

Your performance will be evaluated on **two** equally-weighted criteria:

- 1) **Speed** of Designation
- 2) **Accuracy** of Designation

Please designate as **quickly** and **accurately** as possible.

*Please note that the CONTRAST and BRIGHTNESS controls have been preset and that you will be unable to adjust their levels.

2) Highlighted SAR Update Task

A second condition is a variation of the task described above, however aimpoints are highlighted directly on the imagery and the RFP cards are not used. Once you initiate a trial, a SAR image will appear on the screen. The cursor will appear centered on the image. Slightly offset from center will be a highlighted aimpoint consisting of a red point surrounded by a red circle. Your goal will be to move the cursor a short distance, center it on the red point in the circle, and designate by pulling the trigger.

3) Target Designation Task

In addition to performing SAR navigation updates, the cursor system in the B-2 will be used for targeting purposes. Certain targeting scenarios may require the rapid designation of multiple aimpoints that are separated by long distances on the display screen. A third condition simulates the type of cursor control required for such targeting procedures. In this task, aimpoints will again be highlighted on a radar image. However, each image will contain four aimpoints. Each trial will require the designation of all four aimpoints in a specific order. As a trial begins, one aimpoint will be highlighted in red, and the remaining three will be highlighted in white. Your task is to move to the red aimpoint and designate as quickly and as accurately as possible. Once you pull the trigger to designate, the aimpoint will turn white and a new aimpoint will turn red. You will then immediately maneuver to that point and designate. This process will be repeated until all four aimpoints on the image have been designated, at which time the trial will end.

4) Target Designation Task (Fixed Delay)

A final condition will be very similar to the target designation task described above. The procedures you perform will be identical. However, the delay or lag in the cursor system will be of a fixed length. This differs from the previous conditions in which the delay is of a variable length. This difference may or may not be perceptible to you as a subject.

In each of these four conditions, you will perform designations using **two** cursor system gain functions. These functions will be referred to only as **Function A** and **Function B**. You will always be aware of which function you are using. At certain points during the experimental session, the experimenter will ask you questions regarding the designation task and your performance using each gain function.

*** It should again be stressed that both **SPEED** and **ACCURACY** are important. You should always try to **center** the cursor over the exact aimpoint as quickly as possible. Please do not talk or remove your hand from the cursor controller during the course of a trial. Feel free to comment, ask questions, stretch etc. between trials.

The experimental session should last about two and one half hours. Breaks will be given intermittently as needed.

APPENDIX C

B-2 RADAR CURSOR MECHANIZATION STUDY QUESTIONNAIRE

B-2 RADAR CURSOR MECHANIZATION STUDY QUESTIONNAIRE

SECTION 1: BIOGRAPHICAL DATA

The following section contains questions regarding your background and previous experience that might be relevant to the B-2 radar cursor mechanization study. The information that you provide in this section may be helpful to us in interpreting the data we collect during the study.

A. Personal Data

Name:	Sub ID _____	Rank:
Organization:	Phone:	

B. Experience

1. List aircraft in which you are **currently qualified**, your crew position, and number of hours.

AIRCRAFT	POSITION	TOTAL HOURS
1.		
2.		

2. List additional aircraft in which you have been **qualified in the past**, your crew position, and number of hours

AIRCRAFT	POSITION	TOTAL HOURS
1.		
2.		

3. Which of the following sensors have you operated and how many hours do you have with each type?

SENSOR	AIRCRAFT	HOURS
EVS/FLIR		
SAR		
Other		

4. Describe your experience operating a crosshair using an isometric (pressure actuated) cursor controller to include flight environment (high/low altitude) and hours.

SECTION 2: EVALUATION OF OPERATIONAL SAR UPDATE SCENARIO

(To be filled out immediately following completion of blocks 1 and 2.)

The following section contains questions regarding the operational SAR update procedure.

1. Overall, how would you rate the realism of the simulated SAR imagery presented during the demonstration?

- 1. Very unrealistic
- 2. Somewhat realistic
- 3. Very realistic

2. What simulated SAR effects/characteristics would you improve?

3. Do you feel the aimpoint types (tanks, bridges, buildings, towers, etc.) selected for the demonstration are typical of those you experience in your operational units?

- Yes
- No
- Don't Know

3.a. If not, why?

* Section 2 continued on following page.

SECTION 2 Cont'd

4. How effective was the demonstration in simulating the procedure used for performing radar updates?

- 1. Very ineffective
- 2. Somewhat ineffective
- 3. Average
- 4. Somewhat effective
- 5. Very effective

Explain: _____

SECTION 3: EVALUATION OF ACCURACY ON OPERATIONAL SAR UPDATE PROCEDURE

(To be filled out immediately following completion of blocks 1 and 2.)

The following section contains questions regarding your perceived designation accuracy while performing the operational SAR update procedure.

1. Were you always able to position the cursor on the exact pixel you intended to designate?

- Yes No

1a. If not, on approximately what percentage of trials did you fail to designate the pixel you intended to designate?

Function A: ___ % Function B: ___ %

1b. On average, by approximately how many pixels did you miss the pixel you intended to designate?

Function A: ___ pixels Function B: ___ pixels

Explain: _____

SECTION 4: EVALUATION OF FINE POSITIONING TASK

(to be filled out immediately following completion of blocks 1,2,3,&4)

The following questions pertain to performing fine positioning during the SAR update procedure:

1. Rate the level of difficulty associated with accurately positioning the cursor on the golden pixel.

Function A.

- 1. Very difficult
- 2. Somewhat difficult
- 3. Average
- 4. Somewhat easy
- 5. Very easy

Function B.

- 1. Very difficult
- 2. Somewhat difficult
- 3. Average
- 4. Somewhat easy
- 5. Very easy

Comments: _____

2. Rate the level of difficulty associated with quickly positioning the cursor on the golden pixel.

Function A.

- 1. Very difficult
- 2. Somewhat difficult
- 3. Average
- 4. Somewhat easy
- 5. Very easy

Function B.

- 1. Very difficult
- 2. Somewhat difficult
- 3. Average
- 4. Somewhat easy
- 5. Very easy

Comments: _____

3. Were you able to consistently move the cursor one pixel at a time?

Function A. Yes No

Function B. Yes No

SECTION 5: EVALUATION OF EFFECT OF DELAY

(to be filled out immediately following completion of blocks 5,6,7,&8)

The following questions pertain to the effect of delay variability on cursor placement performance.

1. Did you notice a difference in task difficulty between the fixed and variable system delay conditions?

- Yes No

2. Rate the level of difficulty associated with cursor positioning for each of the system delay conditions.

Variable System Delay

- 1. Very difficult
- 2. Somewhat difficult
- 3. Average
- 4. Somewhat easy
- 5. Very easy

Fixed System Delay.

- 1. Very difficult
- 2. Somewhat difficult
- 3. Average
- 4. Somewhat easy
- 5. Very easy

Comments: _____

SECTION 6: EVALUATION OF GROSS POSITIONING TASK

(to be filled out immediately following completion of blocks 5, 6, 7 & 8)

The following questions pertain to performing gross positioning during the GATS-like targeting procedure:

1. Rate the level of difficulty associated with accurately moving the cursor across large distances (i.e., performing gross positioning).

Function A.

- 1. Very difficult
- 2. Somewhat difficult
- 3. Average
- 4. Somewhat easy
- 5. Very easy

Function B.

- 1. Very difficult
- 2. Somewhat difficult
- 3. Average
- 4. Somewhat easy
- 5. Very easy

Comments: _____

2. Rate the level of difficulty associated with quickly moving the cursor across large distances (i.e., performing gross positioning).

Function A.

- 1. Very difficult
- 2. Somewhat difficult
- 3. Average
- 4. Somewhat easy
- 5. Very easy

Function B.

- 1. Very difficult
- 2. Somewhat difficult
- 3. Average
- 4. Somewhat easy
- 5. Very easy

Comments: _____

SECTION 7. OVERALL GAIN FUNCTION EFFECTIVENESS

(To be filled out after all blocks have been completed.)

This section contains questions pertaining to the overall effectiveness of each gain function.

1. Did you use a different cursor positioning technique for each gain function?
 Yes No

2. Describe the overall technique you used for crosshair positioning.

Function A: _____

Function B: _____

3. Please rate the **overall effectiveness** of each cursor system gain function for designating aimpoints.

Function A

- 1. Very ineffective
- 2. Somewhat ineffective
- 3. Average
- 4. Somewhat effective
- 5. Very effective

Function B

- 1. Very ineffective
- 2. Somewhat ineffective
- 3. Average
- 4. Somewhat effective
- 5. Very effective

Comments: _____

4. Overall, which gain function did you prefer for performing SAR navigational updates and targeting?

Function A

Function B

Comments: _____

APPENDIX D

RESPONSES TO OPEN-ENDED QUESTION ON SUBJECT QUESTIONNAIRE

RESPONSES TO OPEN-ENDED QUESTION
ON SUBJECT QUESTIONNAIRE

In Section-2 of the questionnaire, subjects were asked the following open-ended question pertaining to the realism of the simulated SAR imagery presented during the experiment:

“What simulated SAR effects/characteristics would you improve?”

Subject responses to this question are listed below.

<u>Subject ID</u>	<u>Response</u>
01	“It’s real close to what we see in the aircraft”
02	(no suggestions)
03	(no suggestions)
04	(no suggestions)
05	“Sometimes I’d see a shadow in the (SAR imagery) that didn’t appear in the picture (RFP card).”
06	“(None) that I can think of.”
07	“...For things like towers, they have a tendency not to show up at all...I think they’re gained out because they’re such big bloomers...But I thought simulation was pretty good.”
08	“The fence lines are very pronounced in the airplane. You can pick out the little poles even...The building images tend to blossom more (in the aircraft). The corners are not as well defined and easy to see as they are on here (the simulated imagery). The roads were good. The railroad intersections were good. The dams were good, they looked realistic. I haven’t seen a tower yet...here (in the simulated imagery), it kind of looked like a blob. Storage tanks were very representative of what we see in a SAR image.”
09	“I’d say the quality here is slightly more detailed than what I would see in the airplane.”
10	“The ground/water contrast was pretty good, in some cases (the simulation needed) a little more contrast. The trees tend to show a little better in the airplane.”
11	“This (the simulated SAR imagery) seemed to be a little bit grainier than you’d see as far as the quality of the imagery. But overall, it was pretty good.”

- 12 "...It helps to know what direction of flight you're traveling so you'll know show/no show."
- 13 "The antenna image...was on a tower...the image looked like it was telling you to pick the top of the tower when your coordinates would normally be at the base of the tower."
- 14 "I thought it was about as good as you could make it...You had the shadowing effects. Some things didn't show that well, which happens sometimes."
- 15 "Center of railroad bridges, center of bridges, these looked pretty good. This one, center of tower, looks like you took a photograph and made a SAR image out of it. The others looked good."
- 16 "I would be hesitant (to make suggestions) based on my experience."