

P



*Purdue University
School of Industrial Engineering
Lafayette, Indiana*



D435234

6th

**PROCEEDINGS
Annual Technical Seminar**

DEPARTMENT OF DEFENSE
PLASTICS TECHNICAL EVALUATION CENTER
PICATINNY ARSENAL, DOVER, N. J.

DTIC QUALITY INSPECTED B

**PLASTICS FOR TOOLING
SEMINAR**

sponsored by:
School of Industrial Engineering, Purdue University
in cooperation with
Plastics for Tooling Division of the
Society of the Plastics Industry, Incorporated

19951024 036

FLVIC

@stre@

*MSG DI4 DROLS PROCESSING - LAST INPUT IGNORED

*MSG DI4 DROLS PROCESSING - LAST INPUT IGNORED

~~5430 634~~

-- 1 OF 1

DTIC DOES NOT HAVE THIS ITEM

- 1 - AD NUMBER: D435234
- 5 - CORPORATE AUTHOR: SOCIETY OF MFG ENGINEERS DEARBORN MICH*
- 6 - UNCLASSIFIED TITLE: PLASTIC TOOLING SHRINKAGE TEST METHOD,
- 10 - PERSONAL AUTHORS: LASCOE, O. D. ;
- 11 - REPORT DATE: AUG 10, 1957
- 12 - PAGINATION: 120P
- 20 - REPORT CLASSIFICATION: UNCLASSIFIED
- 21 - SUPPLEMENTARY NOTE: PLASTICS FOR TOOLING RESEARCH REPORTS, VOL. III, 1 AUG 60. (SEE PL42475).
- 22 - LIMITATIONS (ALPHA): APPROVED FOR PUBLIC RELEASE; DISTRIBUTION UNLIMITED. AVAILABILITY: SOCIETY OF AUTOMOTIVE ENGINEERS, 400 COMMONWEALTH DRIVE, WARRENDALE, PA. 15096.
- 33 - LIMITATION CODES: 1 24

-- END Y FOR NEXT ACCESSION END

Alt-Z FOR HELP3 ANSI 3 HDX 3 3 LOG CLOSED 3 PRINT OFF 3 PARITY

Add 430634 - Add 430646

SIXTH ANNUAL SEMINAR

ON

PLASTICS FOR TOOLING

June 11, 12, 1964
School of Industrial Engineering
Purdue University
Lafayette, Indiana

PROCEEDINGS OF THE MEETING

Accession For	
NTIS CRA&I	<input checked="" type="checkbox"/>
DTIC TAB	<input type="checkbox"/>
Unannounced	<input type="checkbox"/>
Justification	
By D 435 234	
Distribution/	
Availability Codes	
Dist	Avail and/or Special
A-1	

Edited by
O. D. Lascoe
School of Industrial Engineering

FOREWORD

The Plastics for Tooling Seminar has been organized and sponsored by the Plastics for Tooling Division of the Society of the Plastics Industry, Incorporated.

Cooperating societies include the Epoxy Resin Formulators Division of the S. P.I., ASTM E, and S.P.E.

Two concurrent sessions are presented each day stressing Plastic Tooling Fundamentals for beginners in the field of plastics for tooling and Advanced Materials and Techniques for engineers seeking more advance information on metallics and their use in industry.

In behalf of the planning committee, a sincere appreciation is expressed to the contributing authors and especially to the companies who have made it possible for the contributing speakers to participate in this meeting:

Ren Plastics, Lansing Michigan
F. B. Wright Company, Detroit, Michigan
General Electric Company, Bridgeport, Connecticut
Kimmell Engineering Co., Harrisonville, Missouri
Armstrong Resin, Inc., Warsaw, Indiana
Marblette Corp., Hazel Park, Michigan
Blehm Plastics, Hazel Park, Michigan
J. P. Stevens Co., New York, New York
Briscoe Mfg., Co., Columbus, Ohio
Lunn Laminates, Ind., Wyandanch, L.I., New York
National Cash Register Co., Dayton, Ohio
Furane Plastics, Inc., Los Angeles, California
Ternstedt Division of G.M.C., Warren, Michigan
Bell Helicopter, Fort Worth, Texas
Stark and Sons, Detroit, Michigan
Dow Corning Corp., Midland, Michigan
Brunswick Corp., Muskegon, Michigan
Full-Mold Process, Inc., Milwaukee, Wisconsin

Wettlaufer Engineering, Division of
Pioneer Engineering, Warren, Michigan

Hamilton Standard, Division of United Aircraft,
Windsor Locks, Connecticut

General Dynamics/Astronautics, San Diego, California

Chrysler Corp., Detroit, Michigan

General Motors Corp., Warren, Michigan

Avnet-Shaw Corp., Plainview, L.I., New York

Meta-Dynamics Division of Cincinnati Milling
Machine Co., Cincinnati, Ohio

Western Electric Co., Bloomington, Indiana

Elox Corp., Troy Michigan

Pratt & Whitney Co., Hartford, Connecticut

O. D. Lascoe
Prof., Industrial Engineering
Purdue University
Lafayette, Indiana

SPI PLASTICS FOR TOOLING DIVISION

C. L. Condit, Technical Division Coordinator, SPI, 250 Park Avenue,
New York 17, New York

Executive Committee

Chairman, Irvin E. Poston, Manufacturing Development, General Motors
Technical Center, Warren, Michigan

Vice-Chairman, Jack Henry Chrysler Corporation, 12800 Oakland,
Detroit, Michigan

Secretary, Edward Ferrari, General Electric Company, 1285 Boston
Avenue, Bridgeport, Connecticut

Treasurer, Alan M. Fullarton, General Dynamics/Astronautics, San
Diego, California

East Coast, Arthur M. Fels, Felso Manufacturing Company, 272-274
E. Ashmead Street, Philadelphia 44, Pennsylvania

West Coast, William Atchley, Furane Plastics, 4516 Brazil Street, Los
Angeles 39, California

Southwest Area, Perry G. Noblett, Bell Helicopter Company, P.O. Box
482, Fort Worth, Texas

Detroit Area, E. L. (Ted) Barney, F. B. Wright Company, 9999 Mercer,
Dearborn, Michigan

Seminar Planning Committee

Prof. O. D. Lascoe, School of Industrial Engineering, Purdue University,
Lafayette, Indiana (Chairman)

L. F. Bogart, Marblette Corporation, (Tool Chemical Company) 29 E. 8
Mile Road, Hazel Park, Michigan (Publicity)

R. H. Kaisch, Rezolin Inc., 35640 South Gratiot, Mt. Clemens, Michigan
(Display)

W. M. Stark, Furane Plastics, Inc., (Stark & Sons), 16147 Meyers Road,
Detroit, Michigan 48035 (Papers)

H. L. Stephenson, Ren Plastics Inc., 1606 Barnsdale Road, LaGrange
Park, Illinois (Work Shop)

E. H. Wiard, Ren Plastics, 5656 S. Cedar Stree, Lansing, Michigan
(Correspondence)

Technical Society Representatives

L. S. Fletcher, ASTME, 10700 Puritan Avenue, Detroit, Michigan 48038

M. K. Young, SPI-ERF, U.S. Gypsum Company, 300 W. Adams Street,
Chicago 6, Illinois

E. J. Morrissey, SPE-C&PT, Plastics Laboratory, The National Cash
Register Company, Dayton 9, Ohio

H. L. Thomas, ASTME, Ren Plastics, 5656 S. Cedar Street, Lansing,
Michigan

N. T. Baldanze, (PLASTECH) Picatinny Arsenal, Dover, New Jersey

TABLE OF CONTENTS

	Section
<u>Organization, Administration, and Management of Plastic Tooling Departments Joe Darragh</u>	A 6297
✓ <u>Basic Principles of Mold Design Used in Casting Plastics Edward Ferrari</u>	B 6297
✓ <u>Plastic Tooling and Miscellaneous Uses for Structural Epoxy Resins Andrew G. Kimmell</u>	C 6298
✓ <u>New Types, Weaves, and Finishes of Fiber Glass for Plastics Tooling Charles L. Langston</u>	D 6299
✓ <u>Integrally Heated Reinforced Plastic Tools, Frank L. Hesse</u>	E 6300
✓ <u>Evaluating Cast Urethanes for Plastics Tooling John Delmonte and Richard Hough</u>	F 6301
<u>Three Economic Fallacies Don Paarlberg</u>	G
✓ <u>Epoxy Fiberglass Spray-Ups for Prototypes and Tooling Aids Thomas Kruger</u>	H 6302
✓ <u>Bagging for Production Perry Noblett</u>	I 6303
✓ <u>Simplified Tooling with Silicone Rubber Molds John Pletzke</u>	J 6304
✓ <u>Fabrication of Plastic Models and Fixtures, Arthur Wright and Sam Callis</u>	K 6305
✓ <u>Pattern-Making in Foam H. F. Shroyer</u>	L 6306
✓ <u>The Use of Plastic Tools in Forming Prototype Sheet Metal Parts F. S. Vanker</u>	M 6307
✓ <u>Production Tooling for Drawing Operations, B. L. Harrison</u>	N 6308

Section A

Organization, Administration, and Management
of Plastic Tooling Departments

Joe Darragh

ORGANIZATION, ADMINISTRATION & MANAGEMENT
OF
PLASTIC TOOLING DEPARTMENTS

by

JOSEPH H. DARRAGH
Regional Sales Manager
Ren Plastics, Inc.
Lansing, Michigan

Presented at
PLASTICS FOR TOOLING SEMINAR
Purdue University
June 11, 1964

ORGANIZATION, ADMINISTRATION & MANAGEMENT
OF
PLASTIC TOOLING DEPARTMENTS

ORGANIZATION

It will be assumed that plastic tooling has been fabricated by this group. Plastic tools have been made on an irregular basis, sometimes six tools have been fabricated, and then some time may have elapsed until additional plastic tooling was built.

Necessary equipment has been obtained, and plastic tooling techniques have been developed. Various individuals in the shop have built or helped to build plastic tools. On some occasions, qualified people are assigned to the plastic tooling program and on other occasions, retraining is necessary to develop additional manpower for the plastic tooling program to replace skills that are on other jobs, and to replace people that may have left the employ of the company.

Future programs and successful plastic tooling application have indicated that some form of organized plastic tooling department should be inaugurated. The main questions are: How should we staff it? What kind of person is the best suited for plastic tooling? What burden rate will be established? How can I obtain the best cost-profit relationship? The best answer to these questions is to perhaps backtrack and see what kind of problems we may have had with the kind of people we first put into plastic tooling.

One of the things I have noticed is this. When technical assistance is offered by formulators, the usual thing we hear is: "We are going to put you with the best man in the shop." This is usually a top grade tool and die builder, or a top grade jig and fixture builder. This man has gone through apprenticeship, and may have 25 years or more in the toolmaker trade. Management assigns this man to the plastic tooling task because he is the most skilled in layout, complex machining and jig-bore operations. He can handle a scraping tool with the skill of a surgeon. He is quite aware of his prowess, and well he might be. He did not get it the easy way. He is extremely proud of his calling, and he is a very necessary man. HE MAY NOT BE THE BEST MAN TO INTRODUCE TO PLASTIC TOOLING.

Why not? This man has many skills in his mind that have been proved successes. He has built many tools, with skills that have been proven. He may think that he is open-minded to new processes. It may be difficult for him to understand that a cast plastic master can be made in two hours, when it would previously have taken 50 to 60 hours to hand polish.

By this time it may be felt that I am suggesting that the most skilled man in the shop is not necessarily the best man for management to assign to plastic tooling functions. Why not? Well, let

us take a look at a typical job analysis for a tool and die maker. Please refer to Job Description and Evaluation Chart for Tool and Die Maker at the end of this paper.

These enumerated skills have put this man in the top labor grade in the tooling shop. Please refer to Job Description and Evaluation Chart for Jig and Fixture Maker at the end of this paper.

The jig and fixture maker has skills that place him in labor grade 14. The top labor grades command the highest wages in the industry. Plastic tooling skills are not as complex as those just described. Management may be placed in a poor labor relations position by finding out someday that the only people in his organization that collective bargaining units will allow to work on plastic tooling is the top grade labor in his shop. This can be very difficult due to schedule conditions, and is costly.

In the event that this discussion may be of interest, the next question is, if not him, who? Well, let us take a look at the charts for Plaster Pattern Maker. (See charts)

Many of the job functions described are similar to the requirements necessary for plastic tool building, although plastic tool builders do not have to have the skills to produce the original model or pattern. The plaster pattern builder is in labor grade 12 which has a reduction in salary range of about 50¢ per hour.

Let us try to set up what would be an accurate description of what we will expect the plastic tool builder to accomplish. (See charts for Plastic Tool Builder.)

THIS IS THE MAJOR ITEM IN THIS PRESENTATION! Analyze the function. Put down on paper what you want the man to do. Define the task. Dexterity is a requirement. A man with an orderly work place is of value. A man with a hungry attitude to please and progress should be considered. A good, bright youngster with an ability for common sense thinking is desirable.

High degrees of tooling skills are not a requirements for plastic tool builders. A person with normal intelligence and willingness can be taught to fabricate plastic tooling in two weeks, with proper instruction.

SUPERVISION

In assignment of supervision, consideration of people with tooling skills that are higher than described will be advantageous, but attitude is a strong factor in this consideration. Knowledge of what plastic tooling can do, and willingness to develop new techniques will be a strong factor in success for the supervisor assigned. This organization and assignment of people should be strongly considered for a department ranging from three men to a

full staff, depending on requirements. Organize with your people, and define the task in detail, and pick your people for potential in plastic tooling, not necessarily for complex toolmaking skills.

ADMINISTRATION

Now, after we have our group of plastic toolbuilders, there are some basic controls to consider. The plastic toolbuilding supervisor, and the most capable hourly rated men should participate in the estimating of new work. This time should not be charged to the present job at hand, but an overhead charge number set up to absorb estimating time. Each tool should have a budget in manhours set up to check the estimate and the performance to the estimate. At the 50% point, supervision should check progress and determine if any unforeseen problem may be causing difficulty. The time to determine budget over-runs is before the tool is complete, not after. All people should be cognizant of the performance that is expected of them, and if problems arise that affect the cost and performance target, they should be instructed to notify supervision immediately.

All material such as glass cloth, epoxy tooling resins, glass fibers, brushes, and items that will be applied directly to the tool should be stored in a crib and issued to the job. Material cost for each tool built must be known, and applied as a basis on future tooling jobs. Inventory records in the material crib must be accurately maintained, and notification of jobs obtained after quoting should be given in order to order material in time to accomplish the next tooling program. In a small shop, supervision is capable of picking up the man-hours expended, and the material applied. In a large program, supervision is more valuable directing the technical aspect of the tooling program, and an additional person may be assigned the function of disbursing material and recording man-hour and material use against the individual tool. This information is invaluable in obtaining future work, and in order to know where you are going, it is mandatory to know where you have been, and how many material dollars and man-hours it took you to get there.

In the administration of a tooling program in epoxy plastics, group like-tools together. Significant economies will be obtained by fabricating two or three tools at the same time. Explore your man loading. You may have figures on building three tools, and will assign one man to build each tool. This means that each man will cut cloth, each man will mix his own epoxy plastic material. Analyze this program, and determine if one man can cut cloth for all three tools, and two men can lay up all three tools. It should not take three times the man-hours to build three tools, if you build all three at once. You will find that by careful planning, that two men can build the three tools as fast, and perhaps faster, than three men could build the three tools separately.

LAY OUT A SCHEDULE FOR THE TOOLING PROGRAM - Draw up a schedule for the program, showing when each tool is to be complete. Indicate the model, pattern, or sample part that the epoxy plastic tool is to be built from. You may find that you are trying to build two tools from the same pattern at the same time. This is difficult. Be sure the schedule is placed in a prominent location in the shop...Do not rely on telling the plastic toolbuilder, "This tool has to be done in ten days." Give him a date, and mention, "This tool is up on the schedule." Also mention, "Be sure you start the tool on the date specified." "If you cannot start the tool on the specified date, I want to know why." It is a prime responsibility of supervision to keep their people cognizant of schedule performance, as well as cost and man-hour performance. The ideal time to impress this on each individual's mind is when you start the plastic tool shop. When your operation is small it is easier to communicate, as the staff is increased, it is only necessary to explain your policy to each member of your working staff as he is assigned to the tooling program.

Rate your people in accordance with their performance, and do not allow creeping incompetence to invade your operation. Lack of courage in reprimanding people for poor performance will discourage other people from working their best. People will follow a pace that they notice other men are applying. Demand an active work pace, and if you do not obtain it from people you will have to take action to obtain performance before your competition resolves the problem for you.

MANAGEMENT

The function of management is to direct an operation to accomplish profit. On many programs the work is quoted, and performance is within the budget target, and the material expenditure was within target. Yet you lost money on the job. This is one way it can happen. The job is quoted at a price, and delivery four weeks after receipt of purchase order. You are notified that your quote is acceptable, and a P.O. is in the mail and will arrive the first of the week. You have 1600 man-hours to expend and there are 40 hours a week. Ten men at forty hours per week, multiplied by four weeks is 1600 man-hours. You have seven men that will be available, so you will try to pick up three more by Monday or Tuesday. Friday afternoon the P.O. and the prints are delivered, and you check the job over with your supervision. Monday morning comes and the model is measured and you start cutting cloth and applying parting agent, and sealer. Your supervisor comes in and notes: It says on the drawing that the hole pattern for the drill jig has to coordinate with master sample part Q-42098. We didn't get the master sample part with the model. You call your customer, and ask when the master sample part will be delivered. You are informed, the master sample part is in the jig bore at the "On Time Tool Engineering Co., Inc." You, mister, are hurt. You have people standing around that cannot go to work. This is the profit you had expected to make.

When quoting the job, do not accept the statement four weeks after receipt of P.O., make a little note in your handwriting on the quote, "and after receipt of all engineering and coordinating material." Do not staff the job until all the material is in your hot little hand. If you get the job, and cannot start on schedule, you are in a position to legitimately proclaim, you will not get delivery on schedule unless you comply with your responsibility. In all fairness the customer has some responsibility, and it may be necessary to explain it to him.

In shops that have business in the machining and hard tool area, with a plastic tooling shop, work is quoted with due regard for man-hours, material, schedule, and the Administrative and shop overhead is applied. It may be found that you do not get as many epoxy plastic tooling jobs as you might. We might take a look at the epoxy plastic tooling cost center overhead versus the overhead applied for the entire operation. You may be supporting three tool designers, and only 25% of one tool designer is used in the epoxy plastic tooling operation. Costs for expensive tracer control machines, and insurance for the entire shop is in the overhead. Rent, heat, power and supervision may be applied at the full rate when the epoxy plastic tooling department uses only 10% of the area, and uses simple machines for the function. You may say, "That is all well and good, but the machine shop and hard tooling departments support the epoxy plastic tooling shop when they are down." My answer is, "They should not." Treat the plastic tool shop as their own separate business, charge off their operation and apply the overhead and administrative costs that are applicable to their operation alone. You may find that they are on a 50 to 75% overhead figure, instead of being burdened with a 175% overhead figure. Quote this way! Do the same thing with the machine shop and hard tool section of your company. Separate the overhead for the functions. This will tell you where your business is profitable, and you will be able to manage with greater definition.

Where quality restrictions are severe, and in-process inspection is required, put the inspection function on a budget, and apply their time as a direct man-hour cost on the job. Normally inspection can be considered overhead, but on some tooling programs direct labor control of some overhead functions is advantageous.

Define the level of decision, and authority of your subordinates. You will have a smoother operation if you allow your supervision to make decisions and understand their level of decision. This may be accomplished by stating that "You will have to make all the decisions on this program, but, keep me advised of your progress." The level of decision will have to be established by normal business contact with supervision and must be a condition of continual improvement. Management must improve the administrative and management ability of their people, and the only way to do it is to give them a portion of management authority. Give your people the authority to define the way overhead funds are spent in their department. Set the overhead target in dollars, and state "I do not care if it is spent in equipment or people. If you can spend it on equipment and eliminate people, I am all for it."

Many times management says, "You have a tool crib attendant, and a clerk in your department for an overhead cost of \$800.00 per month. Your small tool budget and shop supplies amount to \$300.00 per month. We are trying to get about 8% reduction in overhead cost so you will have to reduce your small tool and shop supply budget \$100.00. Please give it a try."

Do not do this. Bring the man in, and tell him you need some help. Tell him he is the best man to make the decision. Where can he help you in reducing the overhead cost in the department. The items in the overhead, are the tool crib attendant, the clerk, and the shop supplies. You may end up with this recommendation. It will cost \$200.00 to move my office and the clerk's office into the tool crib. If we can do this, the clerk can take care of the phone and the tool crib. I will notify the shop people that the crib will be open for one hour in the morning, and one hour before and after lunch, and one hour just before the end of the shift. This way we can surplus the tool crib attendant. What did you get? An overhead reduction of \$100.00? No, you got an overhead reduction of \$400.00 per month, and you only spend \$200.00 to get it. If you ask your supervision to do something for you, you will get exactly what you ask for. If you train and ask your supervision to think for you, you will manage with less effort and greater success.

NOTE: Sample Job Description Charts Courtesy Aeronca Manufacturing Corporation, Middletown, Ohio.

Job Title: TOOL AND DIE MAKER

JOB DESCRIPTION

General Description: Construct and maintain any tool or die required which can be made in the tooling shop.

Specific Duties:

1. Read and understand complicated tool or die prints in order to make tools and dies.
2. Decide sequence and type of operations needed to construct finished tool or die starting with various types of raw stock.
3. Assign part of work to less skilled labor in how to accomplish desired results.
4. Set up and operate any machine in shop in order to make tools and dies.
5. Repair and maintain existing tools and dies.
6. Heat treat all materials as required in making tools and dies.
7. Construct tools and dies within specified tolerances using any measuring device required.
8. Reworks dies to correct deficiencies found to exist under actual operating conditions.
9. Set up, tighten, realign or adjust machines or dies using variable instruments.
10. Perform miscellaneous duties as required.

JOB EVALUATION

Factor		FACTOR ANALYSIS
Degree	Points	
Job Knowledge		Perform skilled trade, uses all type precision equipment. Works from blue prints, designs and sketches. Set-up and operate any machine in shop to build tools and dies.
E	35	
Judgment		Determine operational sequence to be followed in construction of tools and dies. Detect troubles and determine corrective action required.
E	20	
Cost of Error		Extreme care required to avoid errors which could result in losses of up to \$10,000.00.
DC	12	
Working Conditions		Disagreeable working conditions due to exposure to dirt, oil and noise.
C	7	
Instruction		May direct Tool and Die Maker B or C.
B	2	
Fatigue		Standing and walking with considerable visual attention while operating precision equipment.
CB	4	
Safety		Occasional exposure to hazards which could result in fractures or loss of digits.
BB	3	

83

Total Points

Effective Date

Wage & Salary Administrator

Job Title: JIG AND FIXTURE MAKER

JOB DESCRIPTION

General Description: Lays out and makes from tool design, engineering information, sketches, and verbal instructions various types and sizes of precision jig, master tools and fixtures used in the fabrication of complex industrial products.

Specific Duties:

1. From tool design or engineering information layouts and constructs complicated jigs, fixture, master gauges, master tools.
2. Periodically inspect and maintain fixture accuracy by use of master gauges.
3. Interprets and works from jig design prints, sketches, tooling templates, engineering and verbal information.
4. Aligns and assembles jigs and fixtures in locations.
5. Reworks and rebuilds jigs and fixtures.
6. Sets up and operates all machines in the tool room in making required items.
7. Must be proficient in the use and application of all optical equipment pertinent to tooling industry.
8. Plans and lays out sequence of operations.
9. Performs other miscellaneous duties within department, as necessary.

JOB EVALUATION

Factor		FACTOR ANALYSIS
Degree	Points	
Job Knowledge		Performs skilled trade requiring operation of precision equipment including optical instruments. Builds and repairs all type jigs and fixtures.
E	35	
Judgment		Determine operational sequence to be followed in construction of jigs and fixtures. Detect trouble and determine corrective action required.
E	20	
Cost of Error		Extreme care required to avoid errors which could result in loss of up to \$10,000.00
DC	12	
Working Conditions		Disagreeable working conditions with exposure to oil and dirt, some unhandy working conditions.
C	7	
Instruction		May direct Jig and Fixture Maker B.
B	2	
Fatigue		Standing and walking with concentrated visual attention when using precision equipment up to 50% of the time.
CB	4	
Safety		Occasional exposure to hazards which could result in fractures or loss of digits.
BB	3	

83

Total Points

Effective Date

Wage & Salary Administrator

Job Title: PLASTER PATTERN MAKER

JOB DESCRIPTION

General Description: Lays out and fabricates all types of master plaster patterns, clay models and mock-ups.

Specific Duties:

1. Lays out from templates, engineering and loft information, and master tooling, and fabricates all types of master plaster patterns or mock-ups.
2. Mixes plaster to consistency, sets up frame, base and forms and sweeps in plaster to form plaster pattern.
3. Lays out and sets up steel skeletons and plaster template frames for fabrication of full scale models, using contour shrink, drag or sweep templates.
4. Marks and follows trim lines, guide lines and reference points according to print or template specifications.
5. Requires a knowledge of shrinkage, elongation and working characteristics of plaster and metal.
6. Reads and interprets complex detailed prints, and engineering information.
7. Uses precision measuring instruments and plaster pattern makers tools.
8. Performs other related duties within the department pertaining to pattern making, die molding and die finishing as necessary.

JOB EVALUATION

Factor		FACTOR ANALYSIS
Degree	Points	
Job Knowledge		Performs semi-skilled operations in setting up forms and sweeping in plaster patterns. Knowledge of shrinkage and working characteristics of plaster and metal.
D	20	
Judgment		Determine deviations from usual standards and determine operational sequence in construction of plaster patterns; application of reinforcing bars to prevent warpage and shrinkage. Use precision measuring instruments.
E	20	
Cost of Error		Considerable care required since work is of hand skill nature. Loss resulting from improper pattern could exceed \$2500.00.
CC	9	
Working Conditions		Disagreeable conditions due to working with wet material and exposure to dust, fumes and noise.
C	7	
Instruction		May instruct other pattern makers.
B	2	
Fatigue		Sustained physical effort in mixing and molding plaster and close visual attention to trim lines and reference points; up to 50% of normal work time.
BB	3	
Safety		Occasional exposure to minor injuries such as burns, which are not usually lost time in nature.
AB	2	

Job Title: PLASTIC TOOL BUILDER

JOB DESCRIPTION

General Description: Lays up with epoxy tooling resins and glass cloth, or casts epoxy tooling resins to models or patterns, or sample parts, to fabricate plastic tooling.

Specific Duties:

1. Positions model, pattern or part in correct relationship on working surface, working from sketch or tool design.
2. May use clay to fill voids and to make radius fillets between pattern and table or box.
3. Constructs retaining box from wood, or clamped up steel sections to hold plastic in proper configuration.
4. Applies proper parting agents, and sealers to surface of pattern, model or part.
5. Responsible for following printed instructions for the use of parting agents, and epoxy plastic tooling resins.
6. Requires a knowledge of precision measuring instruments to check out position of model pattern or part.
7. Performs other related duties in connection with plastic tooling.

JOB EVALUATION

Factor		FACTOR ANALYSIS
Degree	Points	
Job Knowledge	18	Performs semi-skilled operations in applying parting compounds and sealers with cloth, brush or spray gun. Knowledge of epoxy tooling resins. Works from model, pattern or sample part provided by others.
Judgment	15	Determine accuracy of provided model, pattern or part. Determine operational sequence to fabricate plastic tool in most efficient manner.
Cost of Error	9	Loss resulting from improper technique, or loss of master model, pattern or sample part could exceed \$2500.00.
Working Conditions	7	Disagreeable due to sticky material and exposure to chemical odors.
Instruction	2	May instruct helpers in mixing epoxy plastic resins, and cutting glass cloth.
Fatigue	3	Sustained physical effort is required in glass cloth layups. Attention to technique, and considerable thought is required.
Safety	2	Exposure to industrial dermatitis with some epoxy tooling materials is possible.

53

Total Points

Effective Date

Wage & Salary Administrator

Section B

Basic Principles of Mold Design Used in
Casting Plastics

Edward Ferrari



**BASIC PRINCIPLES OF MOLD DESIGN
USED IN CASTING PLASTICS**

**EDWARD FERRARI
MANAGER • MODEL SHOP
INDUSTRIAL DESIGN OPERATION
GENERAL ELECTRIC COMPANY**

Basic Principles of Mold Design
Used in Casting Plastics

by

Edward Ferrari

Sixth Annual Seminar On Plastics For Tooling
Purdue University
June 11th, 1964

Introduction

Some of the basic materials and methods used in making models and molds have been known for many centuries. New materials are constantly being discovered or developed and are often combined with established methods to produce a relatively new process. The result of this kind of application research is a much greater diversity of techniques from which a choice can be made according to the necessities of the work to be done. The past twenty years have witnessed the addition of many new plastic materials to the techniques employed in making models, molds and cast plastic prototypes. [The primary consideration of which mold material to use is determined by the intricacy of the model and the material used in its construction. The other important factor is the number of castings required and properties of the casting material. The basic mold design will be based on the conditions established by the foregoing considerations. For the sake of convenience molds for casting plastics can be categorized as being either rigid or flexible.] This paper will discuss separately the basic design of these two types of molds.

and see
conclusion p 9
for more

Rigid Molds

The fundamental design principle of a rigid mold is the same in all materials. They can be constructed in plaster, cast or laminated plastic, electroformed metal and cast low-melting point metal alloys.

Plaster Molds

Plaster molds are used when it is necessary to cast only a few pieces the most economical way. When properly sealed with lacquer and thoroughly waxed in order to assure the release of the mold from the cast plastic part a plaster mold will give excellent service. If it is used to cast or laminate polyester resins or high-temperature epoxy resin systems it is advisable to use a film forming PVA parting agent.

The simplest type of plaster mold is one which is made in one piece with an open face. This is possible when the base line of the model is straight and all draft angles permit the draw to be in one direction. (Fig. #1)

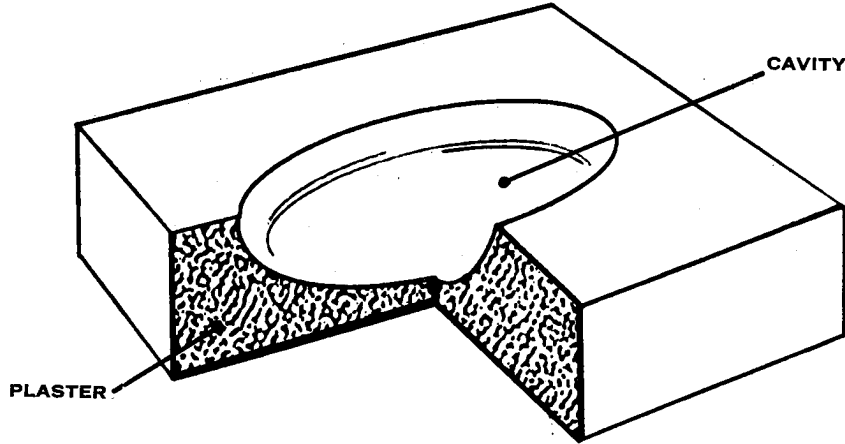

FIG. #1 PLASTER OPEN MOLD

A cored out cast is made by suspending a core inside of the mold cavity. The space between the core and mold face is determined by the amount of wall thickness desired in the casting. The core is maintained in the proper position by a series of bridges whose ends are keyed into the mold. The casting resin is poured through the open space between the core and the cavity. (Fig. #2)

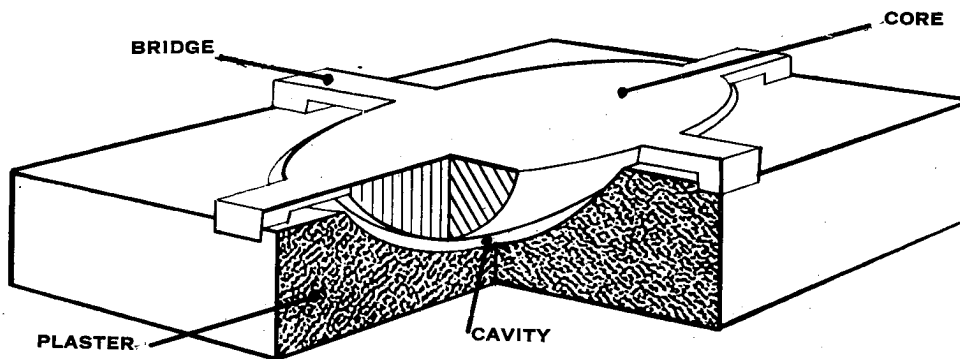

FIG. #2 PLASTER MOLD OPEN CORE

If however the draft of the model is in two directions and a solid casting is to be made the mold is made in two mating halves. Each half mold section will then be removable in the direction of the draw. The parting line will be a point on the model which is tangent to a line which is perpendicular to a common base plane. The parting line may be in a straight plane or according to the configuration of the model will be an irregular line. The two mold halves are properly registered by the keys on the mating faces of the mold. (Fig. #3)

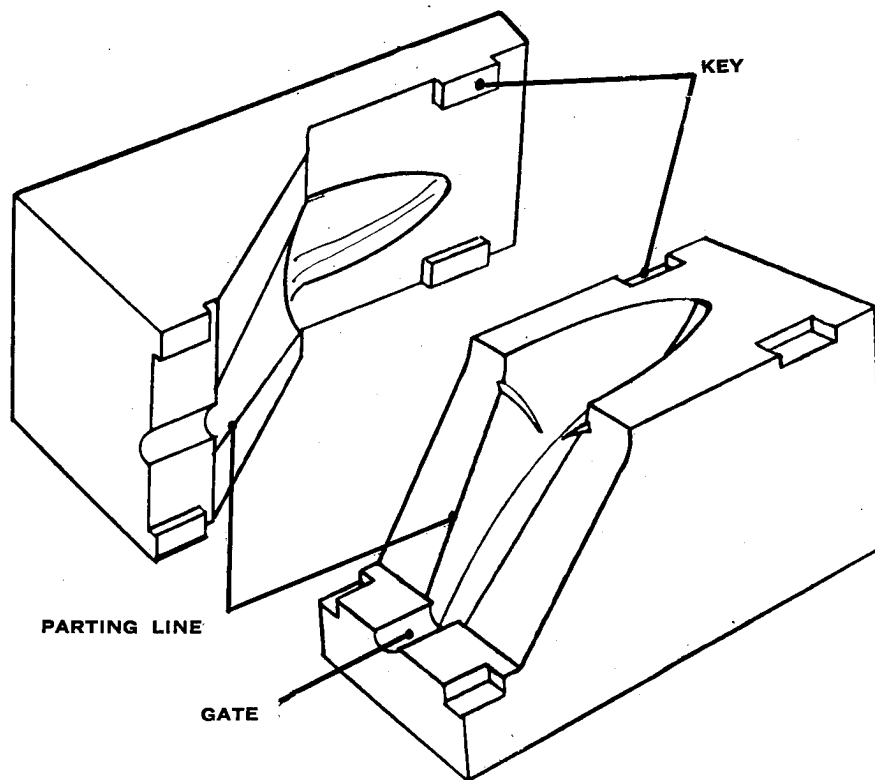

FIG. #3 PLASTER PIECE MOLD

Due to the fact that the average casting resin system has a degree of exothermic reaction during the curing cycle it is necessary to cast models with a wall thickness of not more than one quarter of an inch. Therefore in addition to the mold pieces of the cavity a core must be constructed which will determine not only the wall thickness but will also register the internal webbs and bosses in the casting. This is shown in Fig. #4.

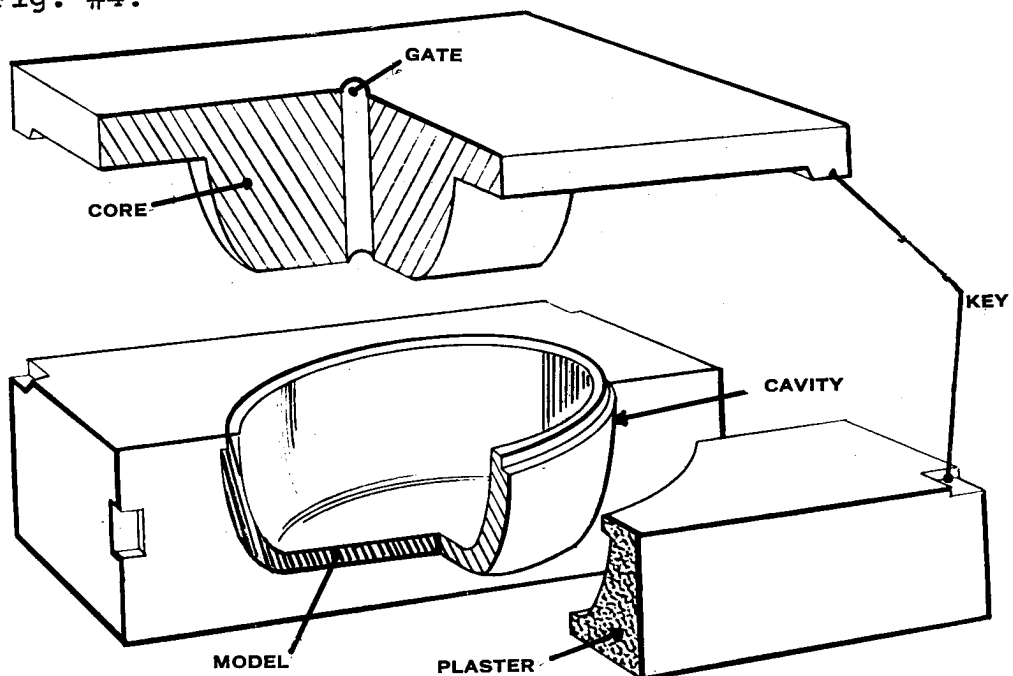

FIG. #4 PLASTER PIECE MOLD — CLOSED CORE

Reinforced Plastic Molds

Reinforced plastic molds are used when many parts are needed. The surface finish achieved in the finished part, the methods used in casting them and the durability of the mold are the determining factors in the use of this material. The construction of this type mold is the same as is used in any reinforced plastic tool. A surface coat of resin is applied to the model, fiber-glass cloth reinforcement is laminated with resin onto the face coat and a back up of mass casting resin is cast over the laminate. The finished mold can be made whatever thickness is necessary according to the size and application of the mold. The same mold designs shown in Figs. #1 - #3 can be used in constructing a reinforced plastic mold. Small molds can be made by using the mass casting method. Sometimes the mold design is influenced by the internal design of the part. The location of webbs and bosses will establish where the gate will be placed and the manner in which the mold will be parted to permit proper venting of entrapped air in the mold. The removal of the core pieces is often facilitated by the use of a draw bar. Fig. #5 illustrates this design principle.

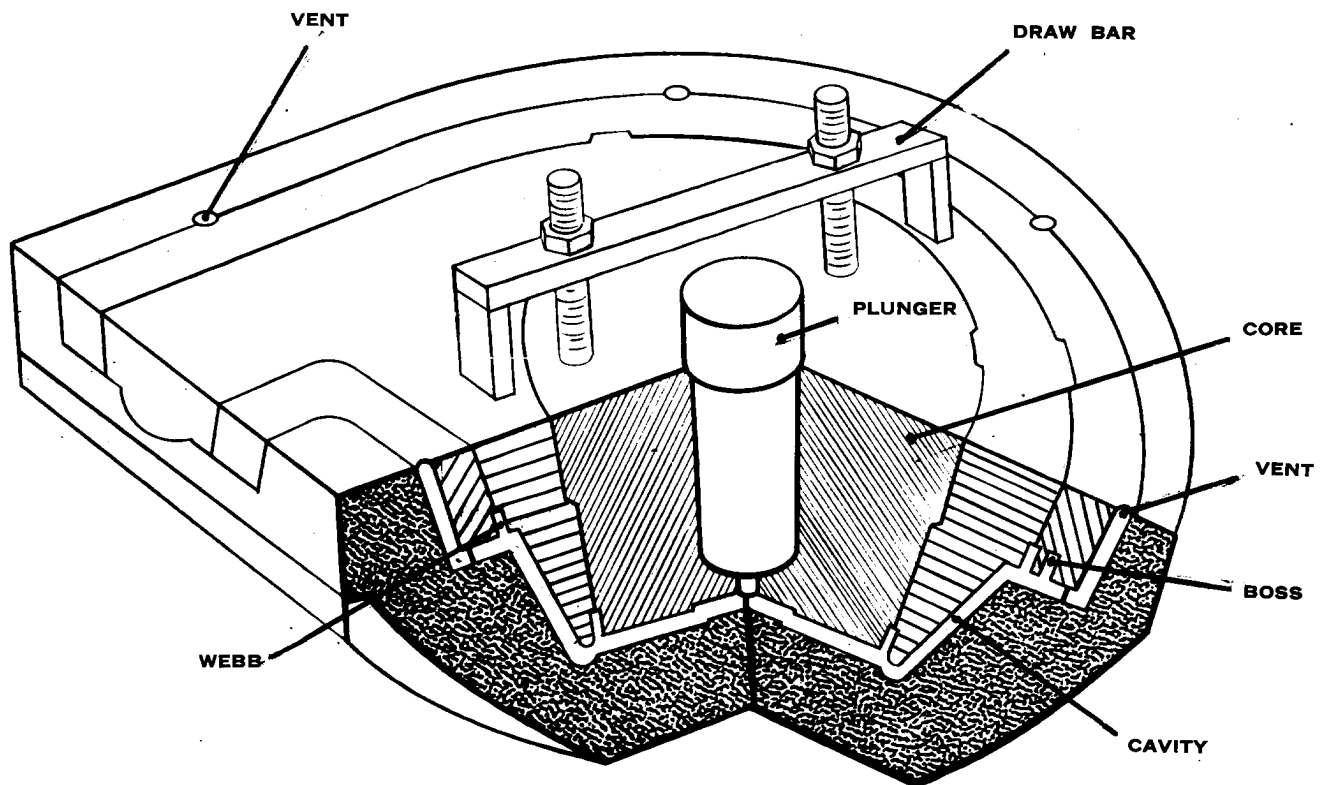

FIG. #5 REINFORCED PLASTIC MOLD

In order to insure bubble-free castings several systems are used. Vacuuming the resin before pouring also the mold during the pouring process. Placing the filled mold assembly in a pressure tank at

50-80 PSI during the curing cycle is another simpler method. Excellent results are achieved by producing pressure on the casting resin by means of a plunger in the pouring gate. The gate is located on the parting line of the mold so that half is in each half mold section. Filling the mold is accomplished first by gravity feed. The core of the mold is partially opened to permit venting until the mold cavity is filled. The core is then firmly clamped and the plunger is inserted into the gate. Pressure is applied after the gel time has begun and is continued until the resin ceases to flow. This mold design is shown in Fig. #6.

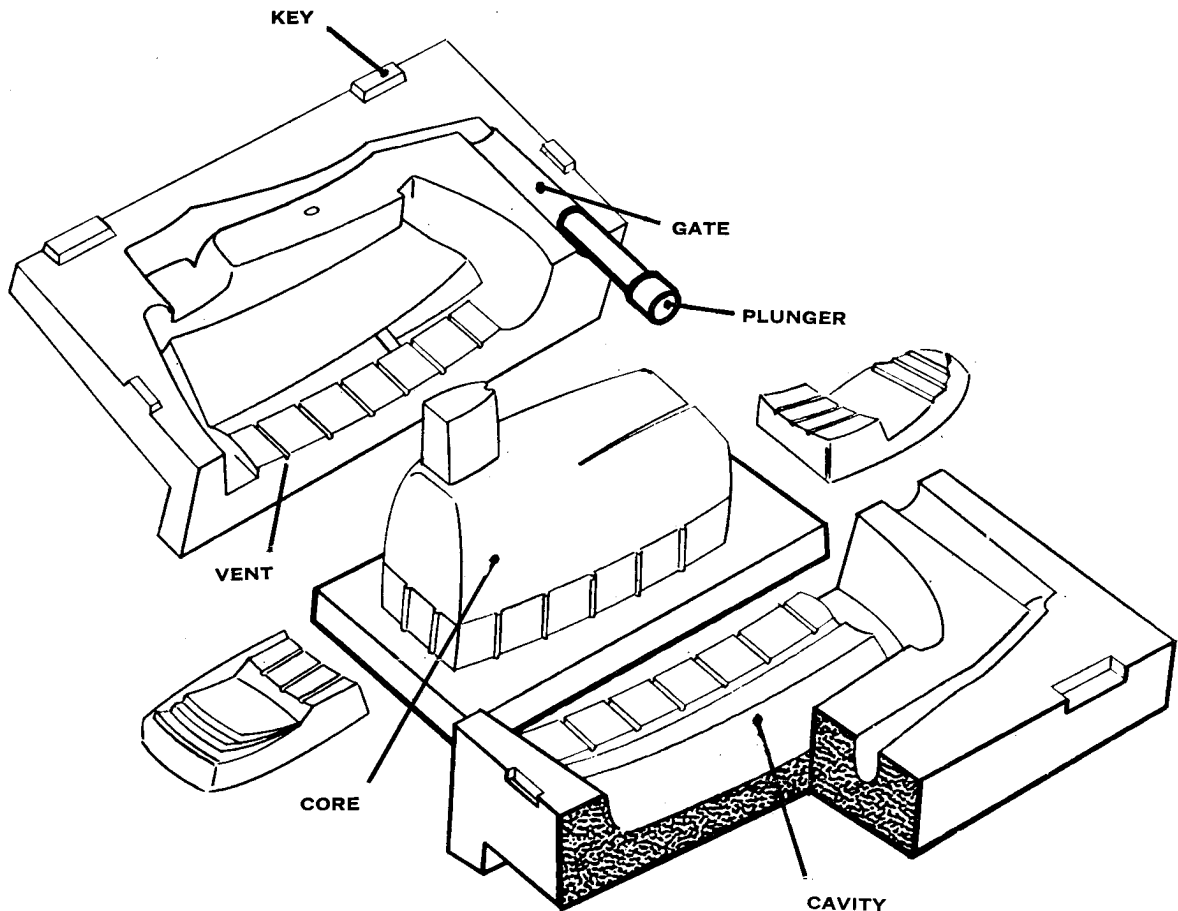

FIG. #6 REINFORCED PLASTIC MOLD

Metal Molds

Metal molds are used to cast clear cast epoxy resins and vinyl plastisols. The reason for this is that in order to achieve maximum clarity in clear cast parts the surface of the casting must have a good polish. This is best achieved by having a polished surface in the mold. Vinyl plastisols cannot be polished in the finished casting therefore they also require the finish to be in the mold. Two kinds of metal molds are used, electro-formed molds and cast low melting point metals.

Electro-Formed Molds

Electro-formed molds must be made on a plastic model in order to avoid any reaction with the plating solution. They are made in whatever number of pieces may be required according to the design of the part. Each piece is electroformed individually on the model. Fig. #7 illustrates a two-part mold.

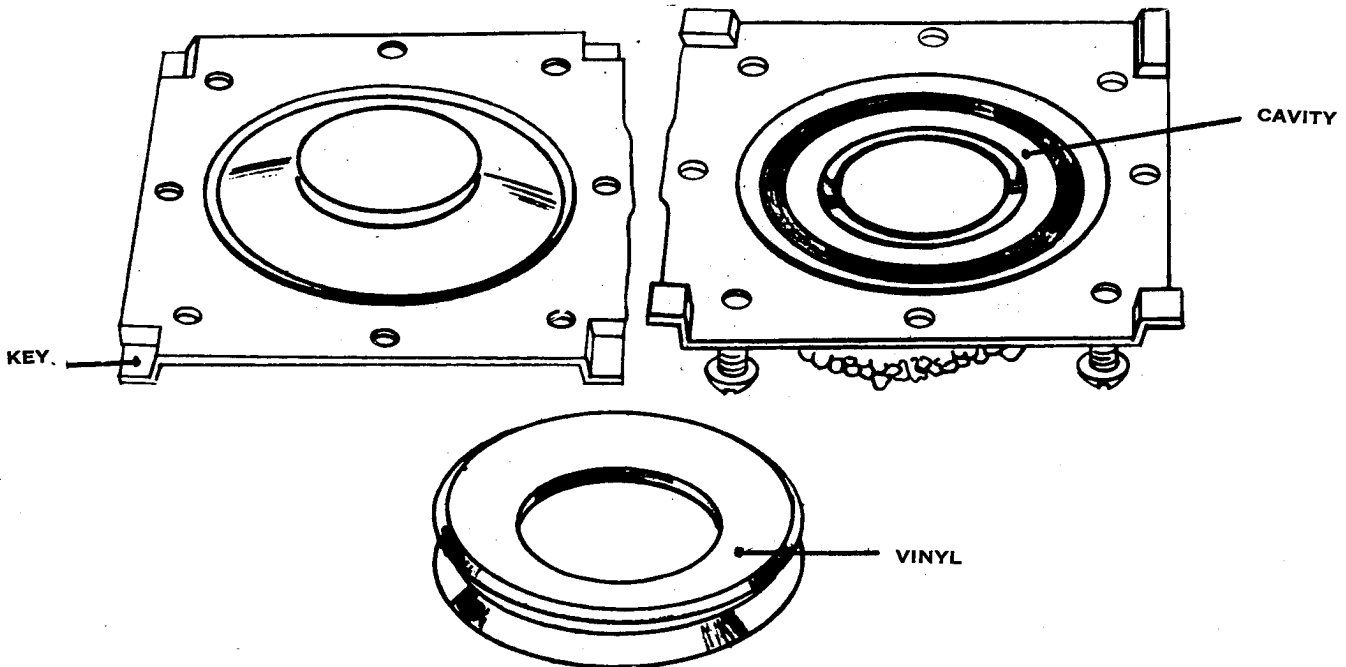

FIG. #7 ELECTROFORMED MOLD

Cast Alloy Metal Molds

Cast alloy metal molds are made by casting them in a plaster mold of each piece required for the mold. If necessary the mold surface can be finished to a smooth polished surface and nickel plated. Fig. #8 shows a two-part mold.

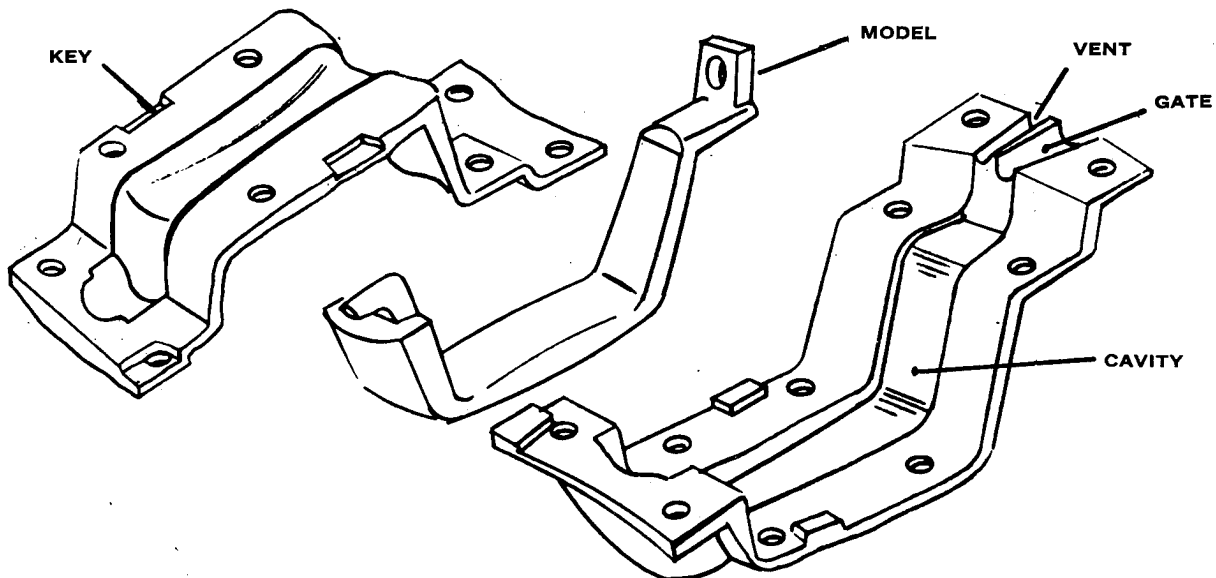

FIG. #8 CAST METAL MOLD

FLEXIBLE MOLDS

Flexible molds are used when a model which has intricate surface detail or contains deep draws and undercuts is to be reproduced in cast plastic. A flexible mold will not only register every surface detail but will release readily from any deep draws or undercuts. Two kinds of flexible mold materials are most commonly used - polysulfide compounds and room temperature vulcanizing silicone rubber. Each one has a distinct area of usefulness according to the conditions set down by the model material and the casting material to be used.

Polysulfide Rubber Molds

Polysulfide rubber compounds are polymercaptan base synthetic resins which are reacted with lead dioxide. They are used when the removal of the mold from the part requires good flexibility and excellent tear strength. They are formulated in viscosities ranging from a pourable liquid to a thixotropic paste. Again the same principle applies in the construction of a mold in this material as is shown in Figs. #1 - #3. If due to the larger size of the mold it is necessary to strengthen the mold a plaster back up is constructed over the rubber mold before it is removed from the model. If the depth of draw is a factor it is sometimes necessary to construct the plaster matrix first over the model and then pour the polysulfide into it. An application of a PVA film forming mold release agent will insure a longer mold life. Also polysulfides must not be used beyond an operating temperature of 200°F. Fig. #9 shows the design of this kind of mold.

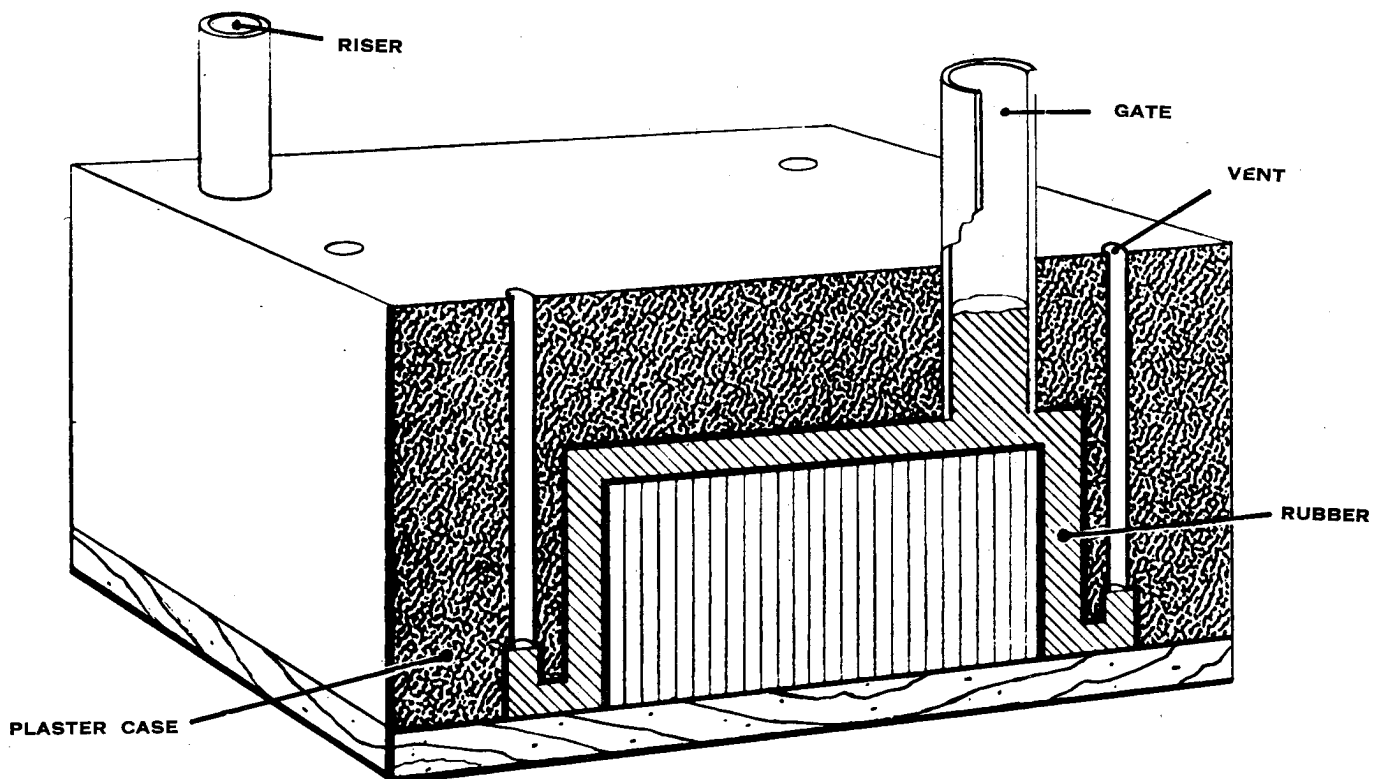

FIG. #9 POLYSULFIDE MOLD

RTV Silicone Rubber Molds

Room temperature vulcanizing silicone rubber molds are used when many castings are to be made. The ability of this mold material to register the finest detail on the original model plus low shrinkage and temperature resistance (600°F.) are factors that determine its use. A single or multiple piece mold can be made in RTV silicone rubber according to the design of the model. Again larger molds are normally backed up with a plaster matrix. Although no parting agent is necessary the mold life can be greatly increased by the use of a paintable silicone release agent. Fig. #10 shows a three-part silicone rubber mold.

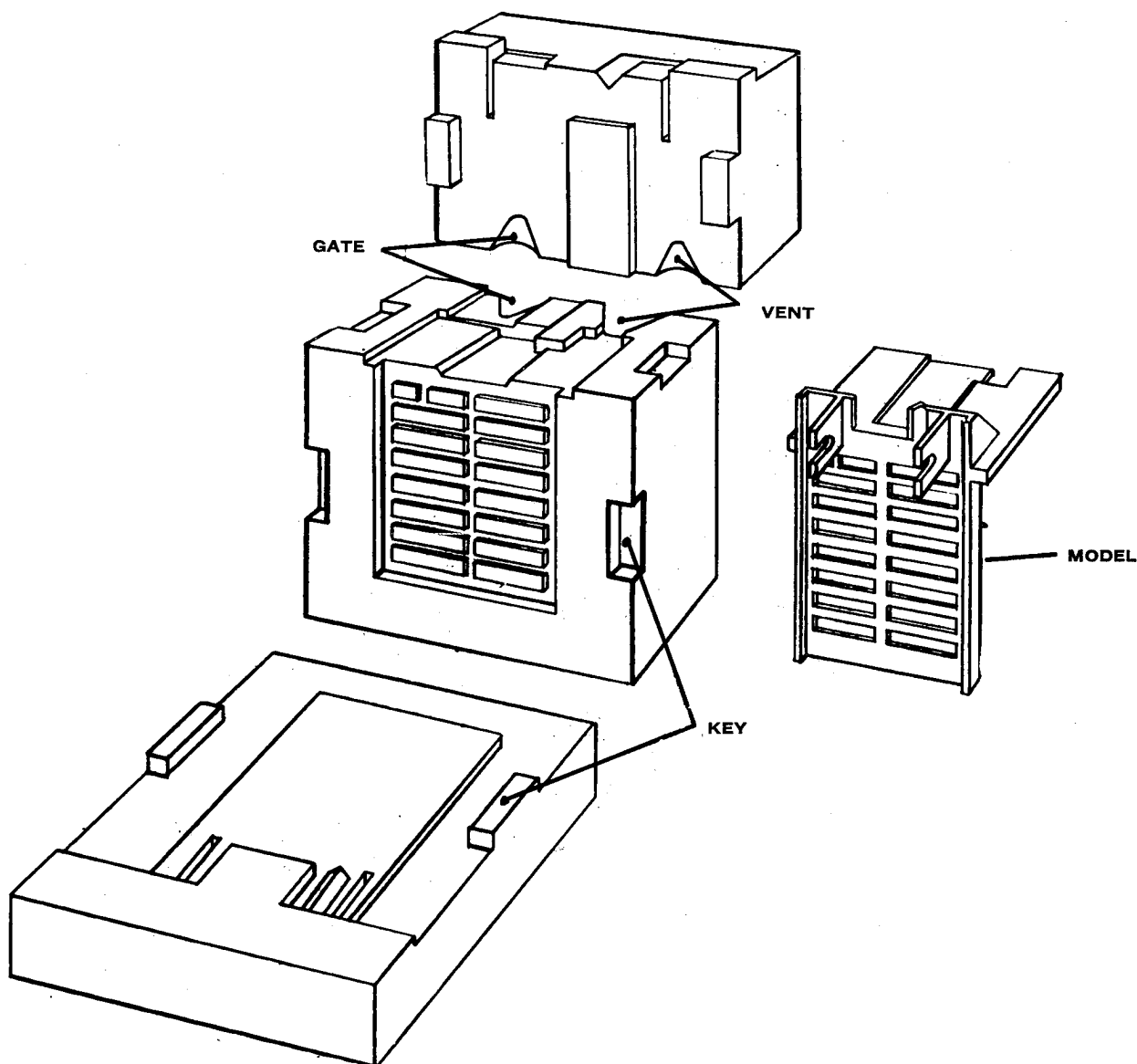

FIG. #10 RTV RUBBER MOLD

Section C

Plastic Tooling and Miscellaneous Uses for
Structural Epoxy Resins

Andrew G. Kimmell

PLASTICS TOOLING AND MISCELLANEOUS USES FOR STRUCTURAL EPOXY RESINS

By A. G. Kimmell
Kimmell Engineering Co., Inc.
Harrisonville, Missouri

Epoxy plastic has been for several years an excellent material for use in reducing lead time and expense in many areas of tool building. In the future, its usefulness in this field can only increase and provide the needed assistance in putting products on the market with greater haste and with better quality.

The first set of slides exemplifies the speed of providing a prototype of a space item that was attained by using epoxy for tooling. The prototype itself was fabricated with fiber glass reinforced with epoxy. A climate suit backpack case used to contain the heating and cooling equipment for a suit used in space travel.

The master pattern of the case was constructed of plywood, plaster and clay. A male mold of reinforced epoxy was made from the interior shape of the master pattern. Inside this male mold was fabricated with epoxy and fiber glass a holding fixture pinned to the male mold. The male mold was then cut in 4 separate pieces, which allowed removal of these pieces from the case one at a time, after removing the holding fixture. The vertical walls of the 8"x10"x14" case would not allow removal of the mold in one piece.

The assembled male mold was next covered with .060 sheet wax to allow for part thickness. The female mold was then fabricated in 5 sections to permit removal from the prototype case. A tolerance of $\pm .005$ was maintained with this method and the project completed in 12 days, in comparison with several weeks needed when using metal. The prototype itself exhibited much higher impact strength than one built of aluminum. Much precious time can be saved when building items of this nature by using epoxy.

In the second group of slides it will be shown that epoxy is truly a structural material only waiting for the construction and building industry to recognize what this material will do.

When Kimmell Engineering built its new plant half way between Peculiar and Harrisonville, Mo. it was decided to use epoxy wherever it appeared to be a useful, functional construction material. All concrete blocks in the walls of the new building were bonded together with epoxy instead of using the usual mortar. Result: walls with mortar joints far stronger than the concrete blocks themselves and less expensive to erect. All doors and door casings fabricated with epoxy and fiber glass, spaced with "epoxy sealed" balsa wood. Result: lightweight, non-corrosive doors with no expansion or contraction from weather change. All wood ceiling joists, venetian blinds, etc. were bonded with epoxy instead of the usual type fasteners. Result: quicker installation better quality.

The entire roof was fabricated with epoxy and fiber glass in 4'x40' sections in the form of a hollow box girder with a 5' arch. The exterior laminate is 1/16" thick; the sides and interior skin of each girder are 1/32" thick. There are 1/4"x1/4" balsa strips in the form of an "X" for assembly bracing every 4'. The 4'x40' roof sections were bonded together with epoxy and bonded to the concrete block walls with epoxy.

The light transmission is excellent, saving approximately \$8,000 in light bills every 6 years. The diffused lighting during the day permits the reading of gages without the usual turning of the gage to eliminate glare from artificial lighting.

The thermal insulation is very good; about average in summer and excellent in winter. The epoxy fiber glass roof has provided sufficient insulation to permit operation of our 3,200 sq. ft. plant through the winter for less than \$500 fuel bill, using bottled gas.

The epoxy fiber glass roof has sufficient impact strength necessary in a hail storm. In April, 1964 our plant was pelleted by 3/4" hailstones, accumulating to a depth of 2½", lasting nearly an hour. There was no damage; hailstones bounced about 10' to 20' high with no ill effects. The epoxy formulating knowledge of Kimmell Engineering proved to be an asset in every respect in the construction of our roof. The heat resistance of our formulations proved invaluable in resisting the hot Missouri sun through our long summers. No deflection or deterioration from the heat or weather has been noted. At this point it must be mentioned that no heavy equipment was needed to lift the roof sections into place. This was done by manpower alone. Each section, comprising 160 sq. ft., weighed only 250 lbs.

Our plant is now 28 months old. There is every indication that every part or portion of the plant where epoxy was used is as good as or far superior to a plant where the usual type construction has been used. The exterior surface of the walls are coated with our own epoxy formulation and since the time of completion of coating there has been absolutely no moisture penetration in any spot or area of the plant.

There is much to be done in many areas of application of epoxy in construction, machine building, house building, medical equipment fabrication, aircraft and space construction. Kimmell Engineering intends to continue to be a leader in this wonderful field of epoxy.

Section D

New Types, Weaves, and Finishes of Fiber Glass
for Plastics Tooling

Charles L. Langston

Reprint of speech given at Purdue University on June 11, 1964, by
Mr. C. L. Langston of J. P. Stevens & Co., Inc., 1460 Broadway,
New York, New York 10036

"New Types, Weaves and Finishes of Fiber Glass for Plastic Tooling"

Fiber glass, and fiber glass fabric in particular, has reached a position of importance in the tooling industry which would have greatly surprised the pioneers in this new technology only twenty years ago.

We believe, however, that the plastics and glass textile industries must be closely tied together and must be responsible for developing new products to meet the requirements of the tooling engineer.

The textile industry is becoming more and more aware of its responsibility. It is our intention to continue to study the problems resulting from the combination of a wide range of resins with an even wider range of glass fabrics. In order to study these problems in depth, we have found it useful to define specific areas of the problem using a concept we call the "glass fabric system."

The following sound slide film will review this basic fabric system for you:

"The Invisible Differences in Glass Fabrics"

We would now like to relate the fabric system directly to those glass fabrics, tapes, and woven rovings which are used to reinforce resins in the manufacture of various types of tools.

First, we shall consider new glass yarn types. The last two

years have seen the introduction of new yarns, with new fiber diameters at both ends of the filament diameter spectrum yarns with new glass compositions, and yarns with varying textures and strengths. All of these add a new dimension to reinforced plastics.

Out of the need of the aerospace industry for a higher strength glass yarn has come S-994 glass. This glass, with a high Al_2O_3 content, results in laminates with significantly higher mechanical properties than obtained from laminates reinforced with "E" glass.

Another significant development with far reaching implications has been the introduction of glass yarns with individual filament diameters averaging 50 times finer than the human hair. These filaments, known as BETA, are at least three times as fine as the filaments now generally used in glass tooling fabrics. The BETA yarns are sufficiently flexible to find usage now in such items as bedspreads and are being studied for use in garments. BETA fabrics offer the plastics technologist a new and interesting area of study.

However, of immediate interest to the tooling engineer is the work on thicker, less expensive filaments. This activity has resulted in lower cost tooling fabrics with improved properties. The best example we can cite is the development of a replacement for Stevens Style 1500, a 10 ounce fabric woven from 150-4/2 yarns. This was replaced in general use by Style 7500, a 10 ounce fabric woven from 75-2/2 yarns. Through the development of new binders and warp sizing compounds, we have been able to weave a 10 ounce fabric using singles 18-1/0 yarns. The construction, number of yarns in warp and filling, is 16 x 14 in each of these three fabrics. The strengths are comparable. The cost

of Style 1800, however, is approximately 20% lower than that of Style 1500.

All of the basic weave types - plain, twill satin, and High Modulus are available in fiber glass fabrics. The type of weave is a major factor in determining the amount of drape or draw available in a tooling fabric. Maximum drape is obtained with multi-harness satin weave fabrics. The satin weave allows movement and formability.

The High Modulus weave, with no reinforcing yarn crossovers, results in laminates with higher impact strengths than laminates reinforced with the more conventional weaves.

Any study of laminate properties should take into account the possible effect of weaving structure on properties.

As we noted in the film presentation, the final part of the fabric system - the finish - determines the functional characteristic of the fabric.

Of course, some glass fabrics are used in the untreated or greige state. Roving fabric woven from glass roving treated with a chemical coupling agent binder is used in tooling directly from the loom.

A new sizing for glass yarn - L-HTS - developed by the Owens-Corning Fiberglas Corporation - appears to offer a means of developing good laminate properties from an untreated tooling fabric. This yarn is only in the development stages, but you should hear more about it within the near future.

In addition to the organo functional finishes described in our slide film, a new finish for use with either polyester or epoxy resins has shown promise as a replacement for Volan. This finish, S-550,

results in higher mechanical strengths than Volan.

We appreciate the opportunity of reviewing with you the areas of development which we in the textile industry are studying. We are hopeful that our work will prove to be of value to the tooling industry.

Lampson

6299

FIBER GLASS FABRIC SYSTEM

The fabric you purchase is made up of yarn, weave and finish. Among these elements, there are many alternative solutions to specific requirements. This mix of variables creates a fabric system, and each of the components in this system can be a massive contributing factor to the profitability of your purchase. There may be more engineering latitudes in each of these elements than you are taking advantage of today.

Take yarn -- Most glass yarn today is "E" glass composition. This is a low alkali lime-alumina-boron-silica glass developed to offer maximum resistance to atmospheric attack, needed because of the tremendous surface area of the individual fibers and optimum forming properties. "E" glass also provides good electrical properties and heat resistance.

New forming techniques today make possible new glass formulations. Tailored to meet such needs are increased chemical resistance, increased stiffness, heat resistance, and tensile strength.

Filament diameter is important, because it affects properties and cost. The range is from "D" fiber at approximately 1/10,000 of an inch to "L" fiber at 6/10,000. These filaments are very fine. The finer the filament, the more flexible the yarn. Generally, the larger the filament diameter, the less expensive the yarn and the fabric. Style 128 for example can be woven from yarns of "E", "G", "H" or "K" filament. The price differential in cost per yard can be almost as much as 55 per cent, depending on filament diameter.

The third yarn variable is form. Most glass fabrics today are

made of continuous filament yarn. This is the lowest cost form of yarn. Staple yarns are used where bulk ratio must be increased at the expense of cost and strength. Texturized yarns are produced by controlling fiber disarray in a strand of continuous yarn through an air-jet process. Texturized yarns yield greater bulk, again at the sacrifice of cost and of strength.

The next component in a fabric system is the weave construction. The ways in which fill or crosswise yarns interlace with warp for lengthwise yarns determines the appearance and functional characteristics of glass cloth. Six basic weaves meet most fabric requirements today.

Plain -- In this weave fill yarn passes over one warp yarn and under the next. This construction provides the thinnest and most dimensionably stable fabric in a given yarn.

Leno -- Two or more parallel warp ends are interlocked around fill yarns to minimize yarn slippage and sleeziness. Relatively open fabrics result.

3 x 1 Twill -- Fill yarns are interlaced with warp yarns so that diagonal ridges are formed across the fabrics. This results in fabrics that are usually heavier, stronger and closer in texture than the plain weaves.

Crow Foot Satin -- In satin weaves, the warp may not interlace with the filling from three to twelve yarns. This weave is used in some uni-directional fabrics, such as for fishing rod reinforcement, and for better drapeability in bi-directional fabrics.

8 Harness Satin weave fabrics have the best drape properties.

They are widely used in highly contoured reinforced fabric applications.

High Modulus -- Is a patented weave exclusively to Stevens. Here structural yarns are held in place with fine binder threads. Interlacing is eliminated, and yarn crimp and shear factors are reduced. The result is maximum physical properties with most resin systems.

Now we will look at the final component of a fabric system - The Finish - Fabric comes from the loom as greige goods, or unfinished material. In this state it still retains an organic starch oil binder applied by the yarn manufacturer to hold the strands together and protect fibers from mechanical breakage during processing and weaving. These unfinished goods are used in electrical applications where the binder doesn't hinder adhesion of electrical varnish, and in reinforced plastics where highest impact strengths are needed. Another loom state fabric is Woven Roving. In this case, the binder is designed for compatibility with resin systems. The next step in finishing some glass fabrics is exposure to heat. Application of 700° heat for a very short time volatilizes some of the binder, the rest is caramelized. This treatment results in a typical brownish fabric. Forms of caramelized fabrics used commercially are finishes 111, 210 and 615. These caramelized fabrics were developed to retain maximum fabric strength while at the same time removing some of the organic constituents which impair adhesion to various coatings. 210 finish is applied to fabrics used for silicone rubber coatings. 111 and 615 finish are used on fabric for the reinforcement of melamine laminates. Finish 615 considerably improves

the electrical and physical properties of reinforced melamine laminates over finish 111. Flexural strength is increased from 45,000 to 75,000 p.s.i. Water absorption is greatly reduced. Because of this superior performance, 615 is rapidly supplanting 111 finish in all melamine laminate use.

Heat scouring is the next finishing process. Here fabrics are held for 72 hours at 650°F until the organic binder is almost completely removed. The resulting bare glass surface is then ready for most coupling agents or functional finishes. Heat scouring glass fabric is designated finish 112. If the heat scoured fabric is to be used in a silicone laminate, it is washed with demineralized water to remove residual alkali trace on the surface. This is 112 Neutral pH Finish.

In order to develop maximum usable properties, a functional finish is usually added to the heat scoured fabric. Most commercial finishes are applied at a dip-tank or padder containing a water solution or emulsion of the finish. The finish is then cured and the fabrics are rolled up, ready for a variety of end uses. Engineering finishing operations to end use requirements is complex and intricate work, but a familiarity with basic finishes can help you recognize and judge fabric quality. Perhaps the most useful way to categorize finishes is by chemical functionality. The first general class of finishes are chromium base. As with all finishes for fabrics in reinforced plastics, the chrome complex has a coupling agent or adhesion promoter between the glass surface and the resin. Stevens offers a range of chromium base finishes today.

Finishes Volan 114, Volan A and Volan AL are applications of methacrylic chromic chloride. The first finish based on this material, Volan 114, has been supplanted by Volan A. Further improvement is Volan AL, a product substantially chloride-free, with slightly improved wet laminate properties. Volan A and Volan AL are useful with a wide variety of resin systems, polyesters and epoxys. Volan A is the work-horse finish. It remains the finish with the broadest use throughout the industry.

Volan E is a new chrome finish designed specifically for bonding or coupling glass surfaces with epoxy resin systems. It contributes exceptional water and humidity resistance.

The next class of finishes is vinyl functional silanes. In the past, these have proven to be of value in developing good dry, and better wet, properties with polyester resins. Currently, there are still two vinyl silane finishes offered - Garan and A-172. Use of these finishes has been reduced since the introduction of another class of finishes -- acrylic functional silane finishes. Polyester laminates with greatly improved strengths have been obtained from glass fabrics through use of entirely new reactive silane coupling agents. Maximum results so far have been obtained with A-174 and Z-6030. The best test of a coupling agent is a strength test of the actual laminate. The acrylic functional silane finish Z-6030 produces flexural strength in laminates far in excess of the standard finish Volan A. This means that effectively, we have developed strength properties in lower cost polyesters previously possible only in epoxys.

Amino functional silane finishes are used in glass reinforced

phenolic melamine and epoxy resins. The amino groups chemically bond with the formaldehyde groups of phenolic and melamine resins and epoxide groups of epoxy resins. Finishes currently offered in this class are A-1100, A-1100 Soft, Z-6020 and Y-2967, a chemically modified A-1100 to give a softer hand to fabric for better drape and wet-out characteristics. Amino functional silanes considerably improve the mechanical properties of phenolic laminates at high temperature. Test results show that after conditioning panels for 200 hours at 500°F, a phenolic laminate with A-1100 retained 83% of its strength, compared to 40% for a Volan A panel. One disadvantage of the amino silane group is that it is catalyst for epoxy cure and if used with epoxy systems can cure resin during prepreg.

A new class of materials - epoxy functional silane finishes entirely overcomes this problem, and at the same time improves properties while offering a softer hand. There are three Stevens epoxy functional silane finishes today -- Y-4086, Y-4087 and Z-6040. These finishes improve electrical and mechanical properties approximately 10% over chrome or amino silane finishes.

Water repellent finishes are not coupling agents at all. In fact they impair adhesion. These finishes are used where water repellency is required to increase wet strength. Most widely used is Quilon, a chrome complex in which the chromium end of the molecule attaches itself to the glass surface and the hydrophobic fatty acid groups become oriented outward, forming an insoluble water repellent finish.

Methyl silanes and methyl phenol silanes are other functional finishes which are not coupling agents. These are applied for high temperature lubricity, such as needed for high temperature filtration. They add glass performance by improving interfiber lubrication, surface abrasion resistance and wet strength at high temperatures. Methyl silanes develop a high degree of water repellency and adequate abrasion resistance at temperatures of 300°F, while methyl phenol silanes extend to the range of almost 600°F.

Weave sets are applied to glass fabrics to improve stability. In many cases they also act as tie coats between glass and elastomeric coatings. Weave sets offered today range from polyvinyl chloride, used to improve adhesion to vinyl film, to silica weave sets used to meet high temperature inorganic requirements. Each is specifically engineered to meet particular end use requirements.

YARN - WEAVE - FINISH

These are the components that make up a fabric system. Because there are many variables within each, selection of the proper fabric may seem complicated, but these variables offer precise and custom designed tools for increased profitability in buying. Stevens facilities, experience and specialists are at your disposal.

Section E
Integrally Heated Reinforced Plastic Tools,
Frank L. Hesse

INTEGRALLY HEATED REINFORCED PLASTIC TOOLS

Ludwig F. Hesse, Vice President
Engineering and Research
Briscoe Manufacturing Company

About the author

The author was graduated from the University of Alabama and pursued advanced studies at the Ohio State University Graduate School. His education and experience is, primarily, in the field of materials and devices. Previous positions include: Research Associate at the Ohio State University Research Foundation, Electronic Scientist in the Electronics Division of the former Wright Air Development Center, Staff Member at Sandia Laboratory, and Research Specialist at North American Aviation, Inc. Inventions include a new technique for Luneberg Lens fabrication. He is the author of numerous technical papers some of which are classified. He is member of the American Institute of Physics and the Society of Aerospace Materials and Process Engineers.

[An increasing number of fabrication processes require integrally heated tools that are compatible with modern short-run production methods. These tools must be economical to build, use and maintain. In addition, they must have inherent reliability, fast thermal response, and good structural integrity over a wide temperature range.

Tools meeting such extensive requirements have been recently developed. Their successful use in production may be attributed to the basic materials and technique used in their construction; namely, reinforced heat stable resins embedded with Briskeat flexible electrical heating tapes.]

The idea of embedding electrical resistance wire in resins to form integrally heated tools is certainly not new. Earlier methods, however, resulted in tools that were tedious to fabricate, lacked uniform heat distribution, and were prone to structural failure. Analysis showed that the large thermal gradient at the wire-plastic interface caused excessive thermal stress and subsequent tool delamination. The lack of uniform heat distribution was, of course, due to the uneven spacing of the resistance wires. One can readily visualize the frustrating task in trying to maintain uniform spacing between wires while embedding them in a viscous layer of resin. The need for new materials and techniques was clearly evident.

During the continual search for new applications of Briskeat heating tapes, it became apparent that their use in integrally heated tools

should be a "natural". The problems of uniform spacing and heat distribution would be solved. Also, the embedding procedure would be greatly simplified. A development program was, therefore initiated to determine if integrally heated tools could be substantially improved by the use of these tapes. Initial results were gratifying. However, it was the development of new and improved tooling resins that led to the ultimate success of these new tools. The program has since expanded to include two major aircraft companies as contributors in a cooperative tool development effort.

A discussion of the composition and properties of proprietary resins used in making these tools is omitted for obvious reasons. There are several manufacturers that formulate tooling resins specifically for this purpose. The resins, of course, should polymerize at room temperature, be easy to apply, and have thermal and structural stability under specified operating conditions.

Considerable information, however, can be given about Briskeat flexible heating tapes. Basically, they are constructed of finely stranded resistance wires insulated with braided fiber glass yarns and knitted into flat tapes. The heating elements and lead wires are made of nickel chrome alloys, nickel copper alloys, or nickel clad copper, depending on their end use. The following sketch illustrates the construction of these heating tapes:

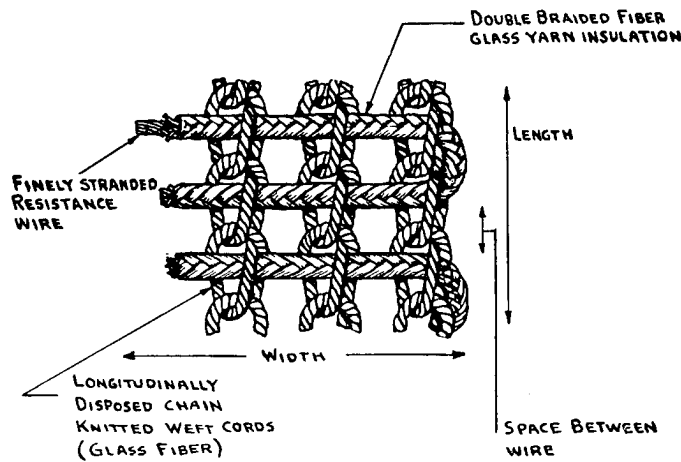

In full scale, a typical 1" wide heating tape would appear as follows:

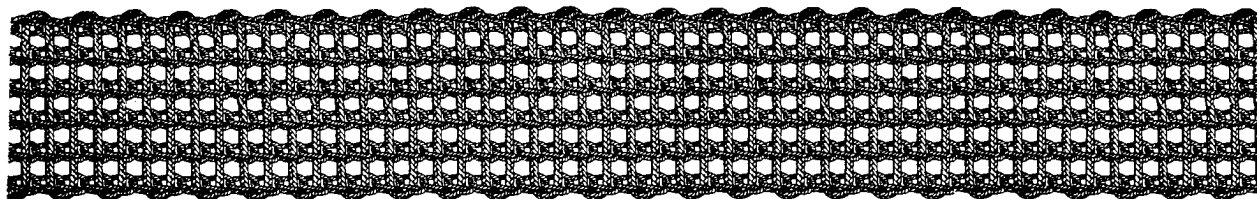

Design parameters of these heating tapes may be varied within a wide range of values. For example,

- Length Unlimited within reasonable power requirements.
- Width 1/4" to 4" in 1/8" increments.
- Spacing between wires . . This factor is dependent on the diameter of the wire and weft cord. Heating tapes are normally made to retain a proper balance between flexibility and insulation. Some have been made that vary from no visible space to 1/4" space.
- Thickness Approximately 1/16" minimum. Additional glass fiber insulation can be added without affecting flexibility. This insulation is in the form of a braided glass yarn sleeving that covers the basic heating tape.
- Resistance 0.3 to 70 ohms per foot of wire.

These heating tapes are easily applied to any surface regardless of complexity because of their high degree of flexibility. They can be zigzagged, spiraled or fanned-out to facilitate covering of any irregular shaped area. The following sketch exemplifies these operations:

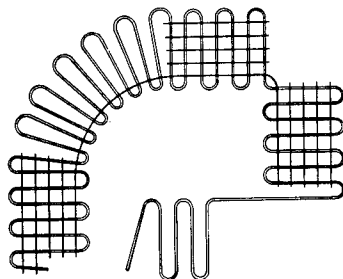

Some of the heating tape qualities that can not be illustrated by sketches are: ruggedness, versatility, quick and efficient heat transfer, and compatibility with resin systems. There is one characteristic, however, that can be most adequately shown by the use of a sketch; namely, the uniform and fixed spacing of resistance wires. Three typical 1" heating tapes are shown on the following page as they would appear in an embedded position. Note the uniform areas coverage.

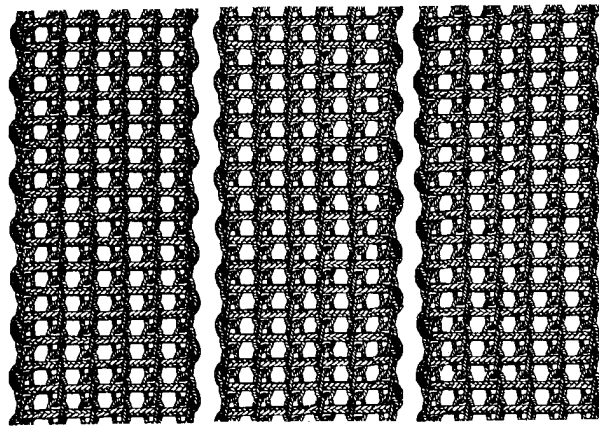

Although individual heating tapes are designed to a specific wattage rating, the heating system may employ a sufficient number of tapes in series or parallel to form circuits of any desired watt density.

Watt density may be defined as the ratio of the power output to the given area. It is usually expressed in watts per square inch. Let us consider the following example: A heating tape, 1" wide and 48" long, has a resistance of 137.8 ohms. Therefore, if operated on 115 volts, the heating tape would deliver 96 watts of power. (In integrally heated tool applications the heating tapes may be considered a non-inductive load; thus, $P=IE$, $I=E/R$ and $P=E^2/R$) The 96 watt output over an area of 48 square inches would be equivalent to a watt density of 2 watts per square inch. On 230 volt operation, this same heating tape would deliver 384 watts over the same given area. In this case the watt density would be 8 watts per square inch.

The relationship between surface temperature and watt density of the heating tapes in a particular integrally heated tool application can not be simply expressed. Heat transfer calculations must first be performed for the given boundary condition. The calculated quantity of heat necessary to achieve the desired surface temperature must then be converted to electrical power equivalents. The mathematical procedure can become quite involved. However, a host of experimental data has simplified the purely theoretical approach.

The watt density requirement of heating tapes in a particular integrally heated tool need not, however, concern the tool designer. He merely defines the cross-sectional boundary, the surface temperature desired, the required time to reach this temperature, and the voltage at which the tool will be operated....and heating tapes will be designed, accordingly, by the manufacturer.

The technique for fabricating integrally heated reinforced plastic tools will be treated in a general, rather than, specific manner. This

approach is taken to avoid cumbersome detail and the call-out of specific proprietary materials. The main reason, however, is to stimulate thinking among those in attendance for newer and better ways to improve this phase of tooling technology.

The initial step in the procedure is the construction of a master mold to establish the required surface geometry of the contingent tool. In some instances the prototype or model of the actual production part itself may be used as the master mold. Since the integrally heated tool is "laid-up" or fabricated directly on the surface of a master mold, it necessarily follows that a male master is used to make a female tool and vice versa. Several factors must be considered in the choice of the type of master mold to be made. Such variables as complexity, preference, prior experience, and ultimate end use of the integrally heated tool itself are involved. In some instances, for example, a more costly female master may result in a tool that is easier to make and use thereby increasing production and lowering unit cost. The reverse could also be true. The decision is, primarily, one of economics.

The master mold may be made of wood, plaster, metal, or reinforced plastic. The choice is of a function cost, required dimensional tolerances, and stability. Regardless of the choice, the surface of the master mold is of utmost importance. Any irregularities in dimension or finish will be exactly duplicated on the subsequent tool.

In order to assure release of the integrally heated tool from the master mold after the tool is fabricated, adequate surface conditioning must be effected. The best recommendation is to follow the procedure set forth by the manufacturer of the particular mold release agent to be used. The master mold may be given an additional coating of a strippable type film such as water solution of polyvinyl alcohol for added assurance.

Fabrication of the integrally heated tool can now proceed as follows:

A thin surface coat of a heat stable tooling resin is applied to the surface of the master mold. This coating is allowed to cure completely. One layer of resin impregnated glass cloth is then applied and, likewise, allowed to cure. The next layer consists of a thixotropic tooling resin having a sufficient "pot life" to allow embedding of the heating tapes. Normally a thickness of 1/16" is sufficient for this layer. The heating tapes are positioned and embedded while the resin is in a semi-cured or highly viscous state. This insures permanent positioning of the tapes during and after the cure cycle.

Note: Air bubbles or pockets in the resinous layers should be avoided. This is not always an easy task. However, it is mandatory that they be eliminated in the final coating, laminating, and embedding operations. It is readily discernable that entrapped air will expand when heated by the heating tapes. The result is blistering of the tool surface and eventual delamination of the heating tapes. The best procedure is to practice coating, laminating, and embedding operations on small test samples to gain the necessary experience.

The heating tapes are positioned in accordance to a predetermined lay-up plan to assure uniform coverage of the heating area. This plan consists of dividing the intended heating area of the tool into imaginary rectangular areas of equal width (corresponding to the width of the tape). Consider the following sketch.

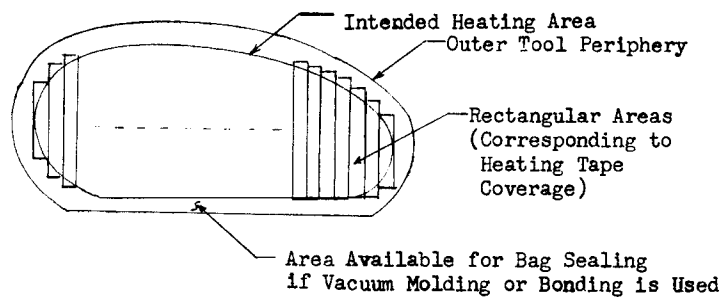

The first heating tape is positioned so that it completely covers the first rectangular area (starting from either end). If the tape length is greater than the length of this rectangle, the web cord is cut at the appropriate point and the tape is continued so that it covers the adjacent rectangular area.....and so on, until the entire heating tape is embedded. Each succeeding tape is applied in this manner until the entire surface area is covered. Of course, each succeeding tape is abutted to the previous one.

After the heating tapes have been positioned in place, the lead wires are allowed to protrude upward (perpendicular to the surface) from the tool. The heating tapes now appear as shown in the following sketch:

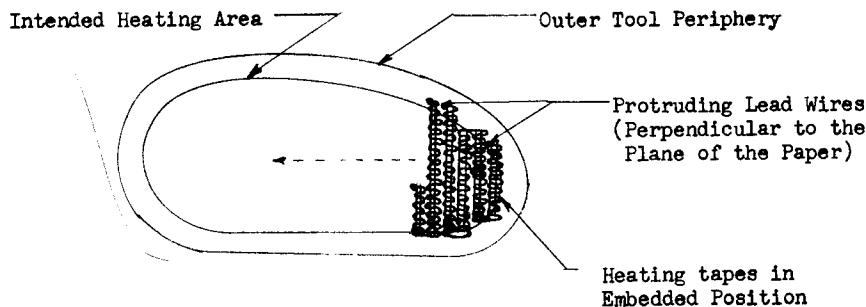

Note: Complete area coverage by the heating tapes is not always necessary. In other words, certain amount of space between tapes may be allowed. The width of this space is a function of operating temperature, allowable temperature differential over the surface, and heat transfer characteristics of the tooling resins. This space can be widened considerably, for example, if the operating temperature is low and the allowable temperature differential is relatively large.

The heating tape leads are now connected together at the place where they abut. The main power leads are then connected to effect a parallel circuit arrangement as follows:*

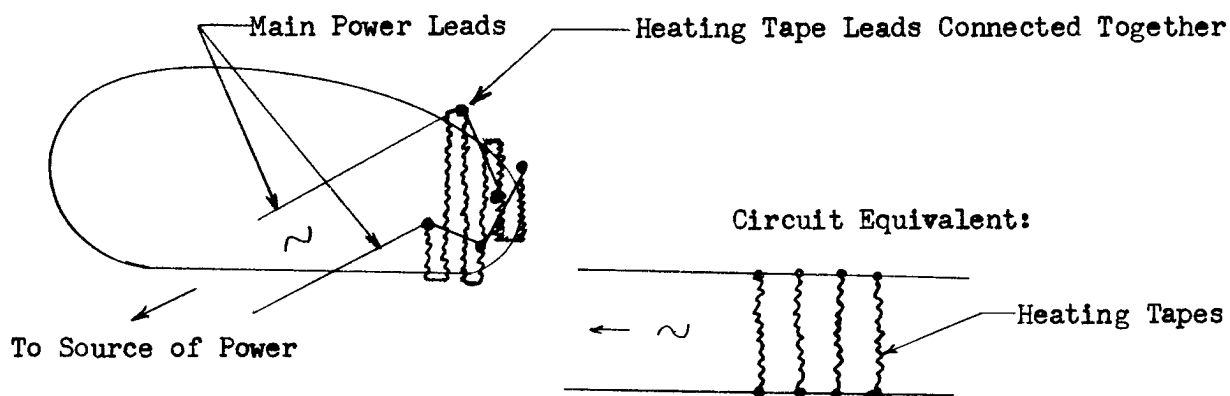

The connections are secured by either soldering or by mechanically fastening them with monel barrels.

Embedding of thermal sensing or control devices is then accomplished. The resinous layer containing the heating tapes and thermal devices is allowed to "set-up" or cure. Several layers of resin impregnated glass tooling cloth is applied. Additional back-up material may be used. The amount and type depends on the desired structural stability of the tool. Materials such as reinforced plaster, paper or glass fabric honeycomb (impregnated with resin), and metal or glass reinforced resin may be used. The selection of any materials used in the construction of these tools is based on the ultimate temperature and pressure to which the tool is subjected to in actual practice.

The cross-section view of a typical integrally heated reinforced plastic tool is shown in the following sketch:

*This arrangement is merely an example. Exceptions exist when three phase power or differential resistance circuits are used.

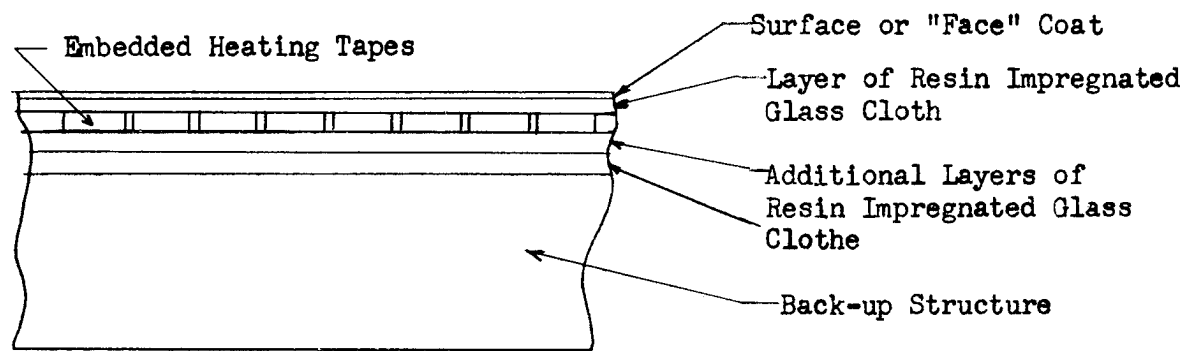

When the back-up materials have been cured and any additional structural framework is applied, the integrally heated tool is removed from the master mold and is ready for surface conditioning and testing.

Surface conditioning of the tool is very important. Repeated applications of mold release agents, baking, and rubbing of the release material into the surface is recommended. Silicone release agents must be avoided if parts produced from the tool are to be painted.

The following are some general notes and hints that will be helpful in the fabrication procedure of these integrally heated tools:

1. Individual heating tapes and the entire heating system should be checked for the proper resistance prior to embedding.
2. Spacing of heating tapes or any fanning or zig-zagging operations should be practiced first on simple test tools to gain necessary experience.
3. When using a number of heating tapes in parallel, as shown in previous sketches, the space between them should be held to a 1/32" minimum. This is a precautionary measure to prevent direct contact of resistance wires.
4. Care must be taken in cutting the weft cords to prevent damage to the resistance wires in the heating tapes.
5. The embedding of thermal sensing or control devices is optional. External control can be effected by autotransformers and percentage controllers.
6. The sensing element of any thermal control device should be located in close proximity of the heating tapes. This distance should be equivalent to the distance of the heating tapes to the tool surface. The thermal sensor will then appear to probe the actual surface temperature.
7. In order to keep the heating tape leads free from resin during the embedding or lay-up procedure, they may be protected by slipping ordinary cellophane sipping straws over them.

8. In large integrally heated tools it is often necessary to follow-up the back-up structure with a framework of steel tubes or other structural shapes.

In summation, it should be repeated that the entire tool fabrication procedure was treated in a general manner. Many variations to the basic technique can be made to suit one's capabilities and facilities. Working on small and simple test tools is strongly recommended and is certainly the best way to gain the "know-how" required in fabricating actual production type tools.

The proven attributes of these integrally heated reinforced plastic tools are certainly worth of consideration. Some of the more outstanding characteristics are listed as follows:

1. Economical to build, use, and maintain.
2. Direct and efficient heat transfer to the intended part. For example, the area between the heating zone and the outer tool periphery remains at ambient temperature even though the heating zone may be operating at a considerably higher temperature.
3. Fast thermal response. This results in shorter production cycles since only the tool surface and not the entire tool structure need be heated or cooled.*

Note: In vacuum bagging operations, a layer of suitable insulation may be placed over the bag if heat retention is an important factor in facilitating cure. If no temperature differential between the inner and outer surface of the part is allowed, two alternate approaches may be used. One is to cover the outer surface of the part with a silicone rubber embedded flexible heating blanket; the other is the use of a matching integrally heated reinforced plastic tool.

4. Variable temperature capability. In some instances, for example, it may be necessary to effect different temperature conditions within the over-all heating area. Some zones may be at a higher or lower temperature than adjacent ones and some may require no heat at all. This condition may be readily accomplished by embedding appropriately designed heating tapes in the prescribed zones (or elimination of heating tapes, altogether, in zones not requiring heat) and then controlling each zone to the designated temperature.

*Because of inherent fast thermal response, the tool should be brought up to operating temperature slowly, in a progressive manner.

5. Versatile. Since a heating system can be designed to operate over a wide temperature range, the tool may be used in determining the most suitable resin system-cure cycle combination. Also, since the tool has its own built-in heating system, parts lay-up and cure can be effected in one operation....and without the need for moving it to and from ovens as is the case with ordinary lay-up or heat bonding tools. This is of particular importance when large and massive tools are to be considered.

All of the above factors add up to lower unit production cost and higher quality parts. The latter is possible because these tools have improved heat transfer control which in turn allows for more accurate control of the curing process.

These integrally heated tools are used, primarily, in heat bonding and small quantity production of reinforced plastic parts. For some fabrication processes, their use is almost imperative. For example, in the heat bonding or laminating of extremely large parts, or in processes where different temperature zones within the same tool are required. The number of uses for these tools is increasing as more and more engineers and production people learn of its advantages and capabilities.

Numerous integrally heated reinforced plastic tools based on the embedded heating tape concept have been built and successfully used in production. Perhaps the largest and finest example to date, is an integrally heated bonding tool built and used by the Columbus Division of North American Aviation, Inc. The tool was used in bonding aluminum skins to aluminum honeycomb core with a heat curing structural adhesive. The resulting honeycomb structural panels were "pie-shaped" or trapezoidal sections of a large paraboloid. The panels were approximately 6 feet wide at one end, 3 feet wide at the other end, and 30 feet long. A surface tolerance of $\pm .015$ inches had to be maintained over the entire panel. The initial resin adhesive system required a cure temperature of 185°F. Because of the unprecedented allowable surface tolerance, the temperature had to be reduced to avoid excessive differential thermal expansion of the skins. The ultimate resin adhesive system required a temperature of 145°F \pm 4° for optimum cure.

Briskeat flexible heating tapes were designed for operation on 440 volts (3 phase) with a watt density rating of 1.2 watts per square inch. Thermocouples were embedded at various points throughout the surface area of the tool. Temperature was recorded and controlled

to the specified value and tolerance.* The huge tool was backed-up with large structural steel tubes to insure dimensional stability.

A Briskeat silicone rubber embedded heating blanket was used on the outer surface of the panels during the adhesive cure cycle, thereby maintaining a constant temperature throughout the panel wall. This technique prevented differential thermal expansion between the inner and outer skins. The procedure was necessary because of the stringent surface tolerance of the panels.

The following photographs (Figure 1 thru 5) describe this tool more adequately than mere words. North American Aviation, Inc. certainly did an outstanding design and fabrication job on this tool. In actual production, the tool performed superbly.

The last photograph (Figure 6) illustrates heating tapes in position during the fabrication procedure of a similar tool.

*Note: A discussion of thermal sensing and control devices has been purposely omitted in this paper. This was done, primarily, because a more adequate description of the type and use of thermal controls can be obtained from the manufacturers of these devices themselves. It should be pointed out, however, that any heating system is only as good as the type and quality of control used.

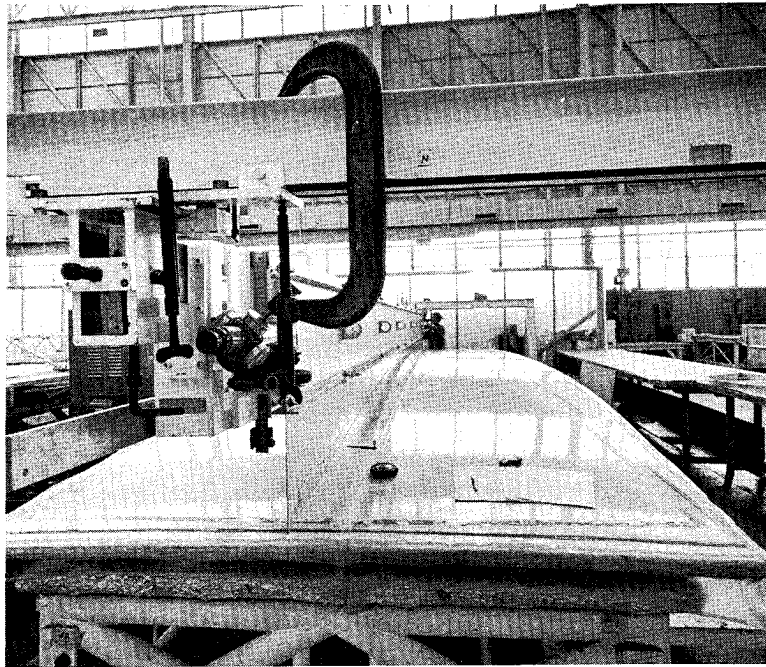

Fig. 1 Tool being checked for Surface Tolerance.

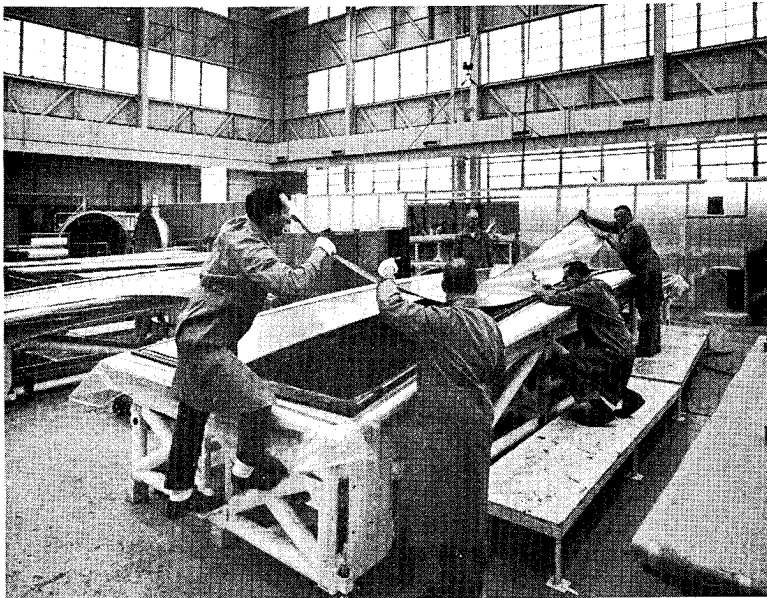

Fig. 2 Outer skin being applied to core.

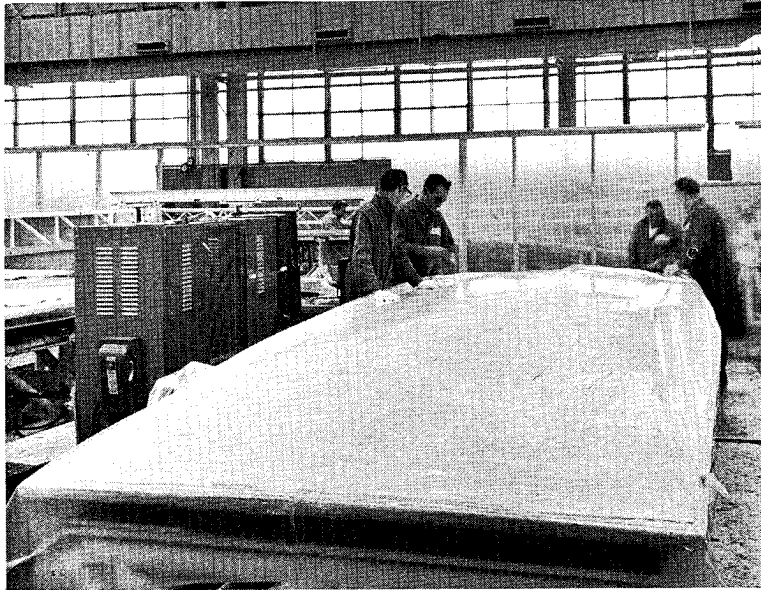

Fig. 3 PVA film being placed for vacuum bag operation.

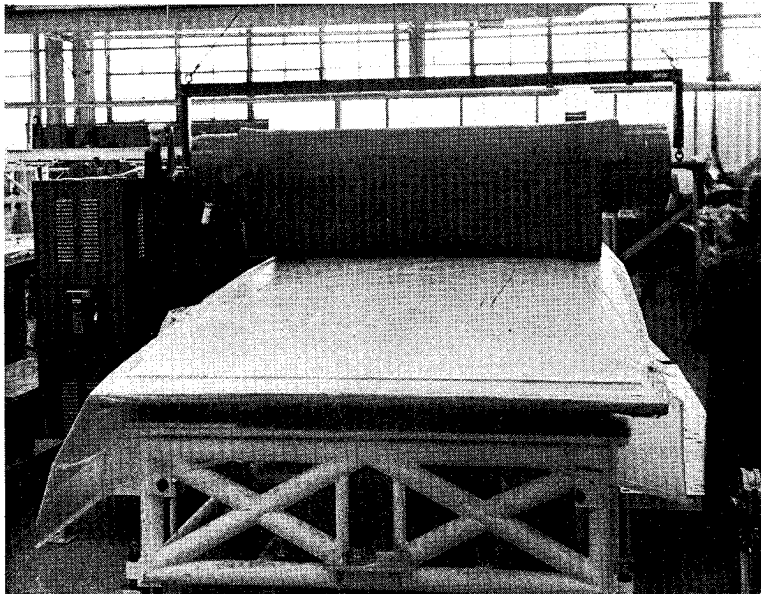

Fig. 4 Silicone Rubber Embedded blanket being placed in operation.

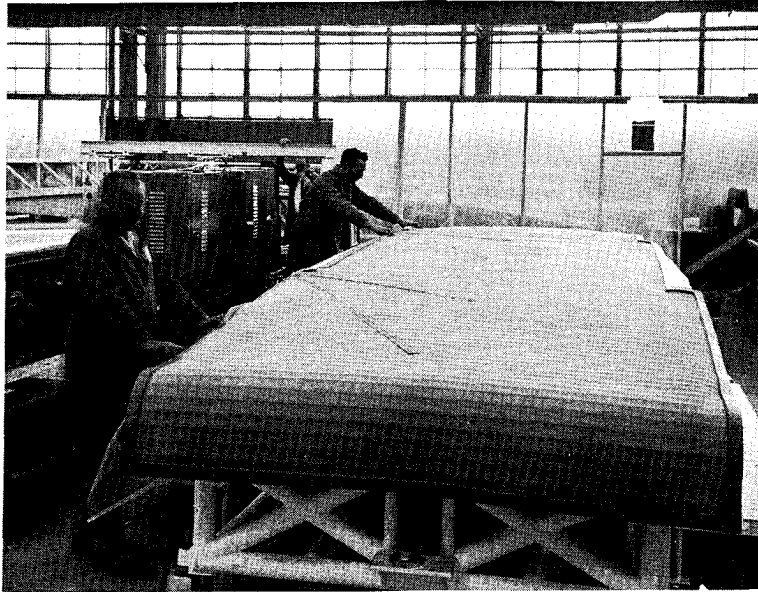

Fig. 5 Ready for the heating bonding operation.



Fig. 6 Heating tape embedded in a similar tool.

Section F

Evaluating Cast Urethanes for Plastics
Tooling

John Delmonte and Richard Hough

EVALUATING CAST URETHANES FOR PLASTICS TOOLING

John Delmonte and
R. J. Hough
Furane Plastics, Incorporated

The emergence of castable polyurethanes on the industrial scene makes available to fabricators of plastics tooling new materials of remarkable toughness. Some cast urethanes surpass vulcanized rubber in those physical qualities important to tool manufacturing operations. More important, cast urethanes lend themselves to well-known processing methods for liquid plastics - techniques with which the tooling industry is well familiar. In analyzing the contributions of polyurethanes to plastics tooling activities, we will highlight those characteristics which are important to tool fabrication processes. Furthermore, your attention will be drawn to those qualities of polyurethanes which are essential to good plastic tooling.

Most of you have undoubtedly become familiar with polyurethane foams which have made their mark in industry in their annual present productions of many tens of millions of pounds. Some of these classes of foamed polyurethanes fit into tooling applications to a limited extent. Polyurethanes, prepared from polyisocyanates and polyols, represent many polymer structures, some of which are adaptable as coatings, others as foams or elastomeric derivatives. Polyurethanes selected for their casting qualities are prepared with a basically different objective: minimum foaming qualities. Casting demands ease of pourability, a useful working life, ready cure at convenient temperatures and the development of physical properties useful to a tooling program.

The salient characteristics offered by cast urethanes are essentially rubber-like qualities and abrasion resistance of a high order of magnitude. To be more specific, Table I compares typical physicals of several castable plastics which have been developed for their rubber-like qualities, and which are capable of cure at room temperatures of 75° to 85° F. Even heat curable plasticized polyvinyl chlorides are inferior in properties to the room temperature cured polyurethanes of comparable hardness.

TABLE I

Room Temperature Cured Cast Elastomers

<u>Product</u>	<u>Typical Hardness Range</u>	<u>Typical Tensile Strength</u>	<u>Typical Elongation</u>
Epoxy-Polysulfides	Shore D - 50 to 70	1,000 to 3,000 psi	25 to 90%
Epoxy-Poyamides	Shore D - 40 to 75	500 to 4,000 psi	10 to 75%
R.T.V. Silicones	Shore A - 50 to 80	300 to 800 psi	up to 100%
Polysulfides	Shore A - 20 to 60	100 to 500 psi	50 to 300%
Polyurethanes (Hi-Extensible)	Shore A - 30 to 50	300 to 600 psi	600 to 800%
Polyurethanes (General Purpose)	Shore A - 60 to 80	1,500 to 3,000 psi	300 to 500%
Polyurethanes (Max. toughness)	Shore A - 85 to 90	4,000 to 6,000 psi	300 to 400%
Polyurethanes (Semi-Rigid)	Shore D - 60 to 70	1,000 to 2,000 psi	50 to 80%

It is clearly evident in Table I that when dealing with polyurethanes we are dealing with a unique class of materials with "rubber-like" qualities, superior to other grades of plastics. It should also be noted that these characteristics are attainable upon readily pourable materials which can be handled by the shop and that the property values are not selected from sheet stocks produced for other purposes. Published values of some elastomeric polyurethanes are predicated upon materials available only to a heated press molded operation. The materials produced in Table I are based on liquid systems which can be cast into tools of various sizes and complexities. Of course, flat sheets are available in the various grades of polyurethanes shown in Table I. These flat polyurethane sheets are frequently employed in press forming of metals.

The net results of these products is to lend new dimensions of toughness and resilience to plastic tooling, qualities woefully lacking in the past. High impact tools, abrasion resistant surfaces, durable molds, flexible cores and snakes, shock absorbing devices, gaskets, rollers, and mechanical goods of wide scope now lie within the experience and capabilities of plastic tool fabricators.

Desirable Qualities in Polyurethane Casting Resins

Pourability

The quality of pourability has been underscored several times because this characteristic has been usually obscured in earlier developments of cast urethanes. Earlier developments might have required heat to dissolve solid catalysis such as MOCA into liquid urethanes, or may have offered pre-frozen kits. These measures represent procedures which we feel are obsolete for plastic tooling, as good liquid curing agents and resins are now available. When the resin prepolymer and curing agent are mixed together in the specified proportions, good pourability will be apparent and, for room temperature curing systems, twenty to thirty minutes working life may be expected. Longer working lives, up to sixty minutes, may be obtained from some systems which may require heat to accelerate cure, though in many cases would completely cure at room temperature over a longer time (seven days) as contrasted to the more rapid setting materials.

The two components, a liquid resin and a liquid hardener, are weighed accurately in their required ration and immediately poured. The viscosity-time curves of a typical general purpose cast polyurethane system are shown in Figure 1 for two different starting temperatures. The higher the initial temperature, the lower the initial viscosity to facilitate pouring. By the way of comparison, a more fluid cast urethane used for complex molds, has its viscosity curve reproduced in Figure 2. Useful working life may be gleaned from the viscosity-time curves with restricted openings for pouring, 25,000 to 30,000 centipoises may represent top viscosity limits. However, for large pour vents, useful pourable viscosities up to 100,000 centipoises may be considered. Pourable urethanes under 8,000 centipoises, at 75° F., are available for tool fabrication. In general, the more rigid tougher polyurethanes for tooling are more viscous, and some preheating before mixing will facilitate pouring.

The contents of opened containers will tend to thicken slowly if contact is made with moist air. Dessicant air filters providing entry to drums are suggested, as well as flushing the drums with dry nitrogen. This precaution will preserve storage life, and dry nitrogen flushing is a packaging procedure practiced by more experienced polyurethane processors. In summation, the tool fabricator should carefully scrutinize viscosity specifications and polyurethane resins and curing agents before purchase is made.

Prepolymers

The resin prepolymer and its chemistry determine properties of the final product. In general, they are prepared from polyols of selected molecular weight and reacted with polyisocyanates, such as toluene di-isocyanate. Among those qualities of good prepolymers desirable to plastic tooling, aside from an easy pourable viscosity, is a low NCO (isocyanate) content. Not only are the better elastomers prepared from prepolymers with less than 6.5% NCO, but they are less susceptible to moisture contamination and less prone to cause unsafe work areas. High toluene di-isocyanate (TDI) concentrations (which appear as high NCO content) are to be avoided. In any event, good ventilation and skin protection are essential, though the problem is not as acute with excessive amounts of TDI.

Storage

Prepolymers and their curing agents should be stored in closed, air tight containers, preferably flushed out with dry nitrogen. When opened, storage life is of necessity limited by contact with moist air. Properly sealed and packaged, at least three to six months may be expected. Freezing weather may crystallize some curing agents which will resolubilize on heating.

Mixing Proportions

The recommended mixing proportions for resin and curing agent should be carefully followed. This ratio is more critical than for epoxies, phenolics, or polyesters. In some instances it may be more prudent to purchase materials in smaller units with contents pre-weighed and ready for blending. This is the more economical procedure because premixing and freezing, as has been done by some manufacturers, increases the cost three or four fold.

Fillers

The selection of fillers for polyurethanes is limited. Traces of moisture or highly polar compounds will contribute to frothing and bubbles. Because thorough drying out is essential, it is recommended that this be performed by the manufacturer of the urethane prepolymer. In principle, the presence of moist fillers does not enhance the tensile strength or elongation of the cured elastomer.

Release Systems

In the processing of cast urethane elastomers, release from

molds and patterns must be considered. Several proprietary releases are available to provide effective separation from other surfaces. Various waxes and silicone release systems have proven effective. In fact, some casting polyurethanes do not effectively bond to fully cured urethanes - suggesting, of course, that the urethanes themselves would make effective molds. Figure 3 illustrates an epoxy casting being removed from a fully cured urethane mold coated with Release C-2. We have used urethane molds in our laboratory for some time, as they have been most effective in the ease with which they are poured and prepared. With an occasional application of silicone release, they have been effective molds for epoxy castings. We have not found these molds satisfactory for polyester castings of laminates.

Adhesion

Plastics tool fabricators, well familiar with the exceptional bonding qualities of epoxy resins, will find that the resilient urethanes do not possess adhesive qualities to as marked a degree. In consequence, if the tool application requires the cast application of a resilient facing to a hard metal tool, it is suggested that primers (such as Primer J) be used on the metal surfaces to enhance the adhesion, and that mechanical means be utilized to insure permanent retention on metal faces. Lap shears in excess of 2,000 psi can be obtained on steel and aluminum surfaces when using semi-rigid polyurethanes and appropriate primers.

Tensile Product

A useful criterion for evaluation of a resilient urethane resin is its tensile product which is some measure of its toughness. Tensile product is obtained by multiplying ultimate tensile strength by elongation. For the typical urethane casting resin, 2,000 psi x 400% equals a tensile product of 800,000. This arbitrary unit gives an indication of the area under a stress strain curve which, after all, is an indication of toughness. Thus, for example, a castable urethane with a tensile strength of 500 psi and elongation of 300% and a tensile product of 150,000 would be that much poorer in performance than the first example cited. Performance is thought of in terms of ability to resist abrasion, tearing, and ability to absorb high impact loads without fracture.

To bring this evaluation to a more scientific basis, a comparison is made in Figure 4, showing the tensile stress-elongation curves of several materials, including a high elongation urethane. These data are the fingerprints of materials of construction and underscore the qualities of castable urethanes being proposed for tooling applications.

Paramount criterion for the selection of castable urethanes are the qualities of tensile strength in psi and percent ultimate elongation. For a given Shore durometer hardness, the product offering the best tensile product would be considered optimum.

Hardness

There are considerable differences of opinion as to the optimum hardness for the forming and shaping of metal parts. In some instances where a great deal of elongation is necessary, a softer grade, such as a Shore A of 70 to 80, would be desirable. On the other hand, harder grades might be more desirable for impact forming of metals and a Shore A of 85 to 90 would be preferred. In any event, it is recommended that the real guide be the tensile strength and elongation of the materials because these are, after all, a measure of their toughness.

Tear Strength

A testing technique, common to the rubber industry, but not to plastic tooling, is the ASTM D-624, conering tear strength. An oddly angled tensile specimen, is cut out of a sheet of urethane by a chop-out die. This specimen is pulled in a testing machine and the breaking load observed. Tear strength is reported as pounds per inch and provides a useful method for comparing the tear strength of rubber-like products. The better grades and stronger grades of cast urethanes are surprisingly insensitive to notches. If problems are posed there are adequate solutions in the use of reinforcing fiber glass, inserted into the molds before the urethanes are poured. Typical tensile products and tear strengths are shown below for cast urethanes, in Table II.

In summation, the quality and usefulness of castible polyurethanes for plastics tooling depend on:

1. High tensile strengths and elongation.
2. Ease of pourability, under 20,000 centipoises mixed viscosity is desirable.
3. Minimum free isocyanate content, say less than 6.5% free NCO.
4. Availability of good primers for adhesion to metal.
5. Preparation for good storage by dry N₂ flush.
6. Avoidance of haphazard filler addition.

TABLE II

	<u>Shore A Hardness</u>	<u>Elongation</u>	<u>Tensile Product (TS & Elongation)</u>	<u>Tear Strength (lb/in.)</u>
Hi-Extensible Urethane (8118)	50 - 60	800%	48,000	100
Flexible Mold Urethane (8059)	50 - 60	500%	15,000	80
General Purpose Urethane (5715)	70 - 75	300%	45,000	200
Max. toughness Urethane (5719)	85 - 90	400%	200,000	300

TABLE III

Problems Associated with Cast Urethanes

Weighing Proportions	Critical - Proportions should follow manufacturers instructions.
Presence of Moisture	Detrimental - Leads to porosity in cured castings.
Adhesion to Metals	Fair - Well cleaned metal surfaces are necessary. Primers are recommended for best adhesion.
Service at High Temperatures (above 200°F)	Poor - Present materials may evince some loss in tensile strength(though elongation and hardness are not changed drastically).
Storage	Requires care - Moist air will contaminate the polyisocyanate resin phase.
Filler Addition	Difficult - Many fillers, due to occluded moisture of their polar characteristics may cause foaming. Leave this problem to your resin formulator.
Safety	Important - Work and handling requires well ventilated areas to carry away fumes. Avoid contact with hands or skin as a general safety precaution.

URALANE 5719
VISCOSITY-TIME

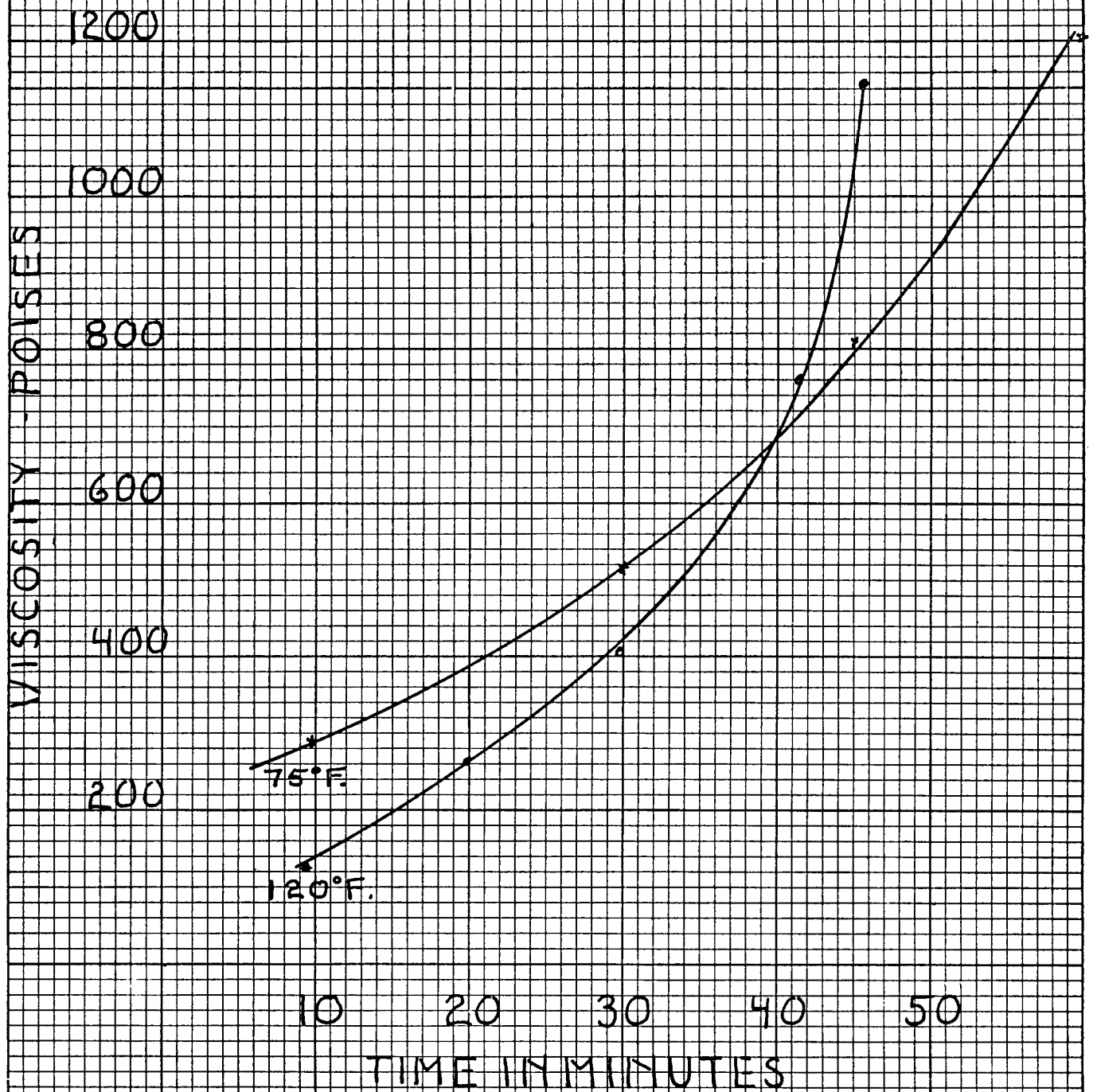

FURANE PLASTICS

MAY 1964

"URALANE" 8059

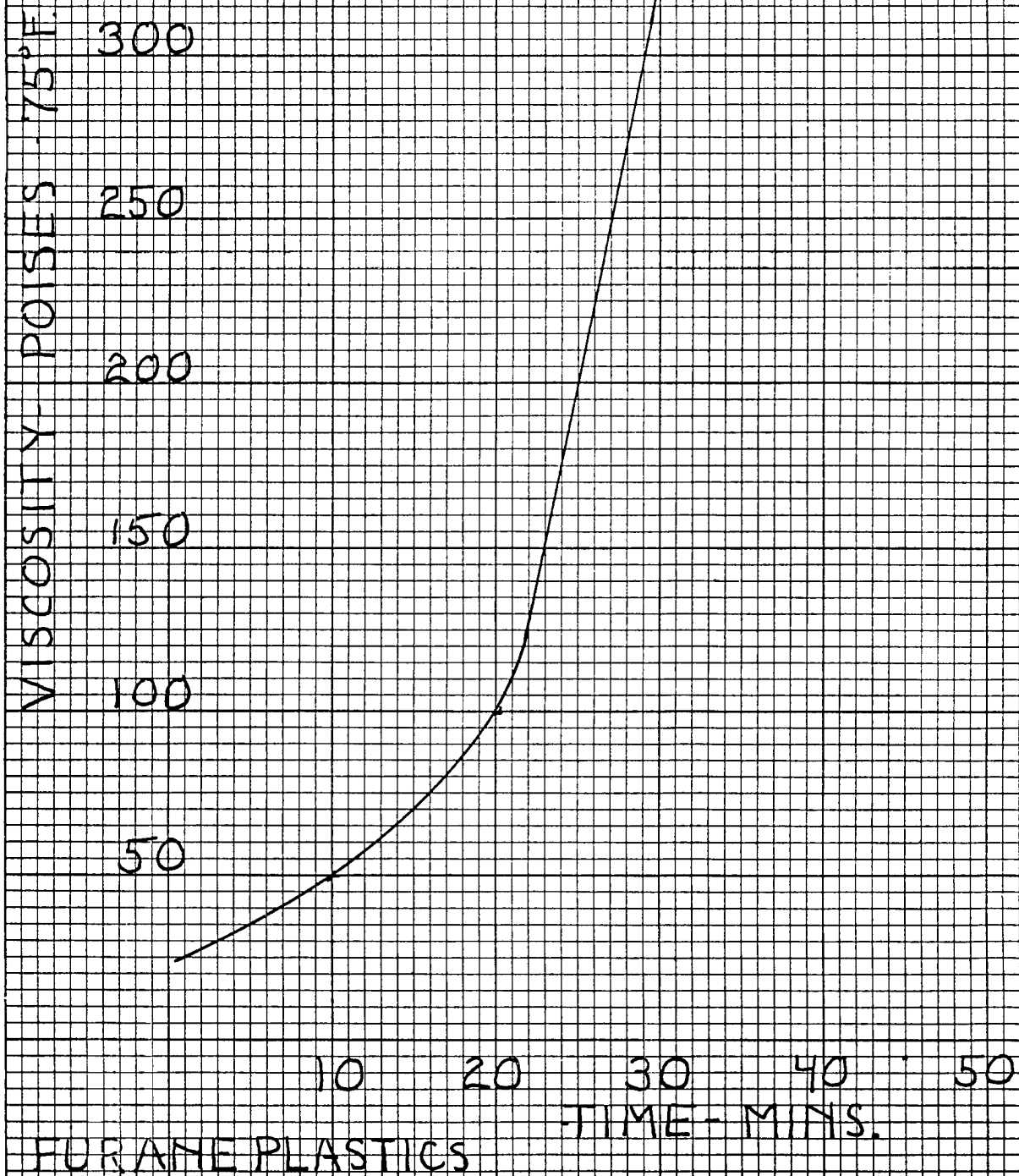

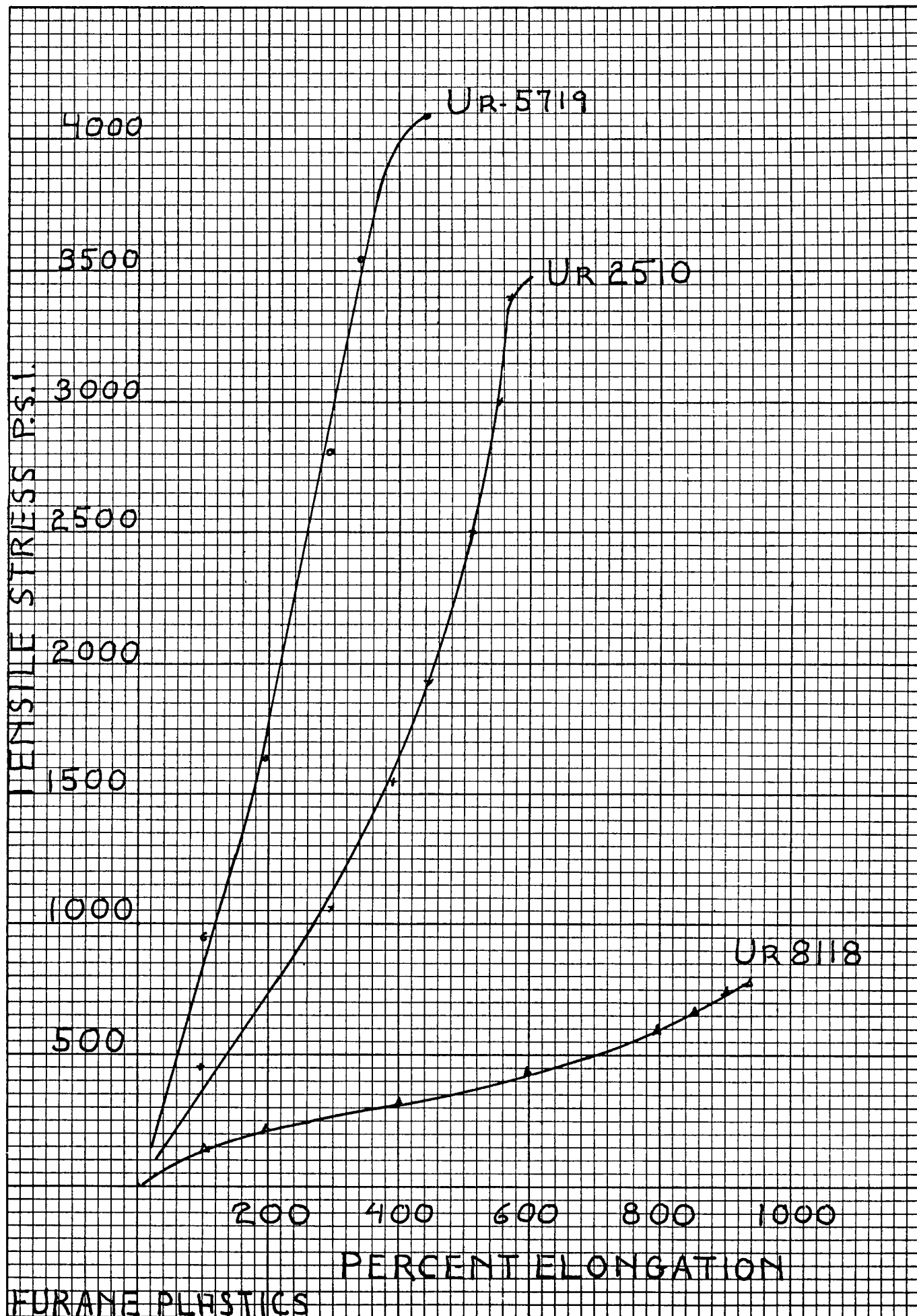

Photo #347. Flexible urethane molds are excellent for casting epoxies and phenolics. The "URALANE" 8118 shown above is a unique example. The removal of an epoxy part is illustrated.

surane plastics
INCORPORATED

LOS ANGELES 39, CALIF.
4516 BRAZIL STREET

Figure 3



FURANE PLASTICS

MAY-1964-

Section G

Three Economic Fallacies

Don Paarlberg

THREE ECONOMIC FALLACIES

Don Paarlberg
Department of Agricultural Economics
Purdue University

It is an honor and a genuine pleasure to address this fine group. This seminar is a fine example of the good work done cooperatively by the University and the commercial community. I am very happy to participate in a most worthwhile endeavor in adult education.

You have one great advantage over me. The public recognizes you as experts in your field. The ordinary man knows he is no expert in the plastics industry and, I should venture, seldom disputes your judgement.

My field is economics, concerned with the use of resources to meet human wants. In this field everybody thinks he's an expert. The only way the expert can exclude the laymen is to develop a special set of technical words, so that nobody but his fellow experts will know what he's talking about. I think, frankly, that this explains much of the economist's vocabulary.

The average man holds beliefs about things economic, even though he may have had no formal economic training. And these beliefs are very powerful. In a country with a representative government, public policy reflects these beliefs even though they may be in error.

Let me give you three economic fallacies which are widely held and very influential, fallacies which are responsible for much of the confusion surrounding public policy. And if any or many of you should happen yourselves to be believers in these fallacies, please forgive what may seem like a personal affront. You may be wrong but you are in the vast majority! And in very respectable company! You have as associates some prominent public figures and, indeed, a few professional economists.

Incidentally, let me say that economics, which is thought by many to be a dull subject, can be and to me is a most fascinating field. There are dull economists, many of them. But the subject itself is not dull. It is fascinating if it is allowed to be relevant; it is dull only if it is penned up, protected, and sterilized. This noon let us try to keep it relevant.

The first and one of the most widespread of all economic fallacies is this: the idea that if someone gains by a transaction, someone else loses. By this belief, if a plastics manufacturer goes ahead financially this is the result of exploiting either his suppliers, his buyers, his labor force or all of these. By this belief, profits are evil and all business is nothing more than a scramble to take something away from the other fellow.

It is easy to see the appeal of this erroneous idea. In a baseball game between the Yankees and the White Sox, if the Yankees win the Sox lose. In an election, if Goldwater wins, Rockefeller loses. If Tom and Dick are courting the same girl and Tom wins her, Dick obviously loses. It is quite natural to believe that if Tom and Dick engage in a business transaction and Tom improves his position it must have been at Dick's expense.

But this is incorrect. It is a fallacy. If Tom and Dick enter voluntarily into a business transaction, both are likely to gain. Being free agents, they would not enter into the bargain unless they expected to gain.

The thing is easy to see in a barter transaction. Tom Sawyer owns a pocket-knife, but places a higher value on a yellow Sunday School ticket. Joe Harper has a Sunday School ticket but places a higher value on the knife. So Tom and Joe trade. And as a result, each is better off. This is perfectly easy to see. But in the modern society, with money as a medium of exchange, it is far more a part of a machine assembled in Detroit and sold in New Jersey. The principle gets lost in the complexity of the operation.

Specialization and exchange is the dynamo of economic life. Voluntary trade can improve the position of all those who engage in it.

True, there is some exploitation and some chicanery in business transactions. The magnitude of it is far less than generally believed. But some is there. These economic fallacies have some truth to them -- just enough so they can't be totally refuted, just enough to make them dangerous.

Exploitation and chicanery occur when people are not well informed or when they are not free to choose. If the people have the facts and are free to exercise their choice, the competitive market is one of the most useful institutions known to man. The way to make the market function intelligently is to see that the people have the facts, and to see that they are free. The opposed view, based on the fallacy that if one gains another loses, leads to the idea of restriction rather than freedom.

If one believes, fallaciously, that whatever someone gains someone else has lost, he mistrusts individual decision-making, he mistrusts the market and feels it necessary to regulate almost every human act. I know of no idea which can so quickly lead us to regimentation as the idea that, in a business transaction, if the other fellow achieves a gain I must have sustained a loss.

* * * * *

A second economic fallacy is the idea that if you treat people equally you treat them fairly.

People are equal before God and before the law. Elsewhere they are not equal. This is not to say that one is better than the other, it is simply to say that they are different. I love my sons equally. Each has his own individuality. Because I love them equally I treat them differently. Not preference of one over the other, just different treatment.

A thing may have usefulness to one person but not to another. Many of you remember rationing during World War II. Everyone got his pound of sugar, whether baker, bartender, baby or diabetic. This was equality. But it was not equity. It was equal but it was not fair.

Economics has a sector which treats the subject of utility, the gratification of wants. Every precept of economics and every empirical study teaches that wants vary enormously from one person to another. To believe that equal treatment is fair treatment is to wipe out all these differences. This is to declare that the wants of all people are the same, and can be equally gratified by dispensing the same article, a preposterous idea.

Presently the Secretary of Agriculture proposes to cut back 10 per cent on tobacco acreage. The cut would occur at this same rate on every farm. without reference to whether or not the existing acreage is appropriate to the farm or to the farmer. One farmer, who in the past planted an excessive acreage of tobacco, winds up with about the right amount. Another, who had cut back a long time ago, finds that he now has not nearly enough. They both get the 10 per cent cut, equal treatment. But not fair treatment.

In many industrial plants the wage rate is required to be the same, though some workers turn out twice as much product as some others. Equality, yes. But not fair.

Aesop tells about the host who treated his guests equally. Soup was served for all, in flat plates. The fox lapped his readily, but the stork, with his long bill, went hungry.

In ancient Greece a cruel King provided an iron bed for his guests. He treated them equally; he made certain that each one fitted the iron bed. Those who were too short were put on the rack and stretched. Those who were too long had their feet lopped off.

There are few things more unfair than the equal treatment of unequals. And when I say "unequals" I don't mean that one is better than the others. I just mean that they are different.

What are the consequences of insisting that everyone be treated like everyone else? Personal injustice, as genuine needs go unmet. Less total satisfaction, as the pattern of one's like is determined by others. Loss of efficiency, as the motive for superior performance is ruled out. Loss of variety, as standardization takes over. Discredit for the enterprise system, which relies on differential rewards as an incentive.

To reward two people equally may be to mistreat them both, if the reward is less than the contribution. The test that should be applied to the treatment which I receive is whether it is fair as it relates to me, not whether it is equal to the treatment accorded someone else. And the best test for fairness that I know of is whether or not I was free to make a choice.

When I was a boy I once made myself ill in an effort to eat as much pie as my bigger brother. I was following the fallacy of equal shares. What I learned by this experience was that the test for how much pie I should eat was how much was good for me, not how much somebody else thought was good for him.

The idea that if you treat people alike you treat them fairly makes things easy for the administrator. It relieves him of an excruciating difficulty, the difficulty of making personal distinctions. Any administered system will tend to treat people equally, out of the sheer difficulty of doing anything else, and any insistence upon equal treatment will lead to an administered system.

There is one kind of equality which we may appropriately seek; that is equality of opportunity. Everyone should have an equal place at the starting line. The error comes when we try to see that they all breast the tape at the same instant.

The idea of equal rewards, regardless of effort, is a first long step toward total regulation and the obliteration of individual differences. It is fallacious economic doctrine and dangerous political ideology. It is appropriate only if individual differences are to be blotted out and each person considered as an anonymous entity in a depersonalized society.

The last economic fallacy I wish to consider is the idea that there actually is such a thing as a free good.

The story is told of a king who wanted to study economics. He went to the library and to his dismay found hundreds and hundreds of volumes on the subject -- far more than he could possibly read. He called his counselor and gave instructions that this vast amount of printed material be reduced to the least possible size. The counselor worked long and hard, ultimately bringing in the result of his labors. "How much have you condensed it?" asked the king. "To one small volume," replied the counselor. "Too much," said the king. "go back and reduce it more." In time the counselor came back again, this time with one page. "Still too much," said the king. "Reduce it still more." After much further labor the counselor returned and announced, "O king, I have now condensed the subject of economics to its ultimate irreducible essence." "How long is it?" asked the king. "Five words," said the counselor. "Good," said the king, "and what are those five words?" "The words are these," said the counselor, "there is no free lunch."

There is no free lunch. Everything has its cost. Everything worthwhile requires the use of resources. If resources are used to produce one thing they cannot be used to produce another. To receive something means to forego something else. The things that seem to have no cost are paid for or supplied by other people.

Trading stamps are not free. They are part of the cost of the groceries or the gasoline.

Your federal highway is not free. Maybe the other people pay for most of it, but as part of the arrangement you will have to help pay for their highway.

Do you have free use of a company car? It is adjusted through your salary. Do you have an expense allowance? Without it your pay check would be larger. Do you have free parking in a downtown lot? It is paid for through your taxes.

There is no free lunch. This is not to say that there is anything wrong about public services. Public education is excellent. Public highways are needful. Public parking is good. But just don't get the idea that they are free!

In fact, some of these seemingly free things are very expensive. Tax-supported public programs are a bit like a big dinner, with each man's bill being a share of the total rather than related to what he himself eats. If he were to order hamburger instead of steak he would

save practically nothing. With everyone reasoning this way, of course, the meal is often very good, the total bill high and each one's share larger than if he bought his own dinner.

Belief that there is such a thing as a free lunch leads to the demand for more and still more services, based on the idea that they don't cost anything. The demand for a valuable service, if it is thought to be free, is virtually insatiable.

* * * *

These three economic fallacies all lead us in the same direction -- toward less reliance on the individual and toward more centralized decision-making. They all weaken our reliance on the enterprise system and on the market economy.

In a representative government it is within the power of the people to deprive themselves of economic freedom. If they do this with full knowledge of the alternatives and the consequences, few will dispute their right to such a choice. But if they deprive themselves of freedom without wanting to do so and without knowing how or why freedom was lost, this is an entirely different and a far more serious matter.

To see that people have the knowledge with which to make intelligent choices is the responsibility of economic education. I am not sure that economists have fully faced up to this responsibility. We have spent far too much time on some of the refinements of our subject and far too little on lifting the economic literacy of the public generally.

And to see that people are economically literate is also the responsibility of the enlightened citizenry. This is a task which can't be delegated or farmed out. And I know no class of people who better understand the market economy -- and who have a greater stake in its proper functioning -- than the business community.

Our system involves individual enterprise and representative government. This system has given us the highest level of living and the greatest amount of freedom ever enjoyed by any nation.

This system is now on trial. We shall never succeed with it unless we understand it. It is jeopardized at least as much by those of its friends who misunderstand it as by its enemies who wish to overthrow it.

The great majority of the people in this country believe in freedom. If they are armed with understanding as well as the love for freedom they will win out. Business people have the responsibility and the opportunity to lift the level of economic literacy. This is an

area in which their self-interest and the best interest of the country are wholly consistent.

Technically we are well advanced. Soon we will land on the moon. But in the field of economic understanding we are still at a very elementary level. In terms of economic understanding the country is at about the same stage, relatively, as the plastics industry was before we developed an understanding of chemistry. In the modern day this just isn't good enough! We economists have to do better! And you business people and practical citizens have to help us!

Section H

Epoxy Fiberglass Spray-Ups for Prototypes
and Tooling Aids

Thomas Kruger

6302

EPOXY FIBERGLASS SPRAY-UPS FOR
PROTOTYPES AND TOOLING AIDS

A paper to be given by T. E. Kruger on June 11 (or 12), 1964, before the 6th annual "Plastics for Tooling" seminar sponsored by Purdue University in cooperation with the societies of the Plastics Industry and Plastics Engineers and the American Society of Tool and Manufacturing Engineers.

Mr. Chairman:

I feel honored that, at the recommendation of the planning committee, Professor Lascoe saw fit to invite me to speak to you about Ternstedt's practices regarding epoxy-fiberglass spray-ups for the manufacture of prototypes and tooling aids. The description of "how we do it" could not be complete without telling you how we got into it. Neither should I keep from you the many important applications for which we have adapted it. In fact, we are so dependent on spray-up fabrication that without it, we could not handle the volume and variety of work that came to us as a result of this advance over hand lay-up.

More about this story in a moment.

Slide 1 - Ternstedt Crest:

The Ternstedt Division of General Motors of which I am an employe, gained divisional status on January 1, 1949. This division has manufacturing plants in 7 cities -- Cleveland, Ohio; Columbus, Ohio; Detroit, Michigan; Elyria, Ohio; Flint, Michigan; Trenton, New Jersey; Syracuse, New York.

Additionally, it maintains General Administrative Offices in Warren, Michigan where all centralized activities are carried out. One might

mention - Purchasing, Quality Control, Production Control, Finance and Accounting, Process Development, Product Engineering, Production and Manufacturing Engineering, Laboratories, and Engineering Shops.

Salary and hourly employes total over 24,000 persons, which ranks us fourth domestically in the Corporation. Our products are manufactured to make automobiles more attractive inside and out, and to make many of their major components more useful, more convenient, or safer. Yet, these products, as important as they are in enhancing the appeal of the automobile, are not readily identifiable with our division, so, I am certain that a partial listing will greatly surprise you by their diversity.

We make hinges and lock systems for doors, deck lids and hoods.

We make die cast handles found on both sides of the doors.

We provide the seat adjusters in a variety of designs.

Mechanical and electrical control of door and rear quarter glass movement is accomplished by regulators and switches made by this division.

Many components of the exterior and interior decor come from our manufacturing plants such as garnish, reveal and drip moldings, scalps, radiator grilles, bezels, wheel discs, hub caps, and scripts, in fact, we have over 6,000 different shipping items made from steel, zinc, stainless steel and plastics, both extruded and molded.

A continuous and effective product improvement program requires the services of engineering shops where advancing ideas can be translated into prototypes by expeditious and appropriate means. The division provides such facilities for its own purposes and for that of their customers.

You will get some impression of its size by looking at this slide.

Slide 2 - Layout of Shop

The Shop measures 180' x 480' which means an area of 86,400 sq. ft. including aisle space. The center is given to general machining supporting the activities located at the sides. It is at the upper right and left where the bulk of our prototype work involving the previously mentioned products is carried out. Further below we note the fixture and gauge building area adjoining the wood shop.

At the bottom you can see the areas provided for the foundry, the wood mill and the plastic shops.

Total shop employment stands at 340 employees supervised by four general foremen and 17 foremen.

The Engineering Shops of Ternstedt Division have built plastic checking fixtures and similar structures by a hand lay-up method for many years. This work consisted of impregnating suitable glass cloth with epoxide resins by means of hand brushes applying several such impregnated layers consecutively in order to reach the specified thicknesses. Each job required the attention of one man who worked on a separate worktable.

Slide 3 - Partial View of Plastic Shop

There are 12 such tables equipped with individually adjustable exhausts. The table

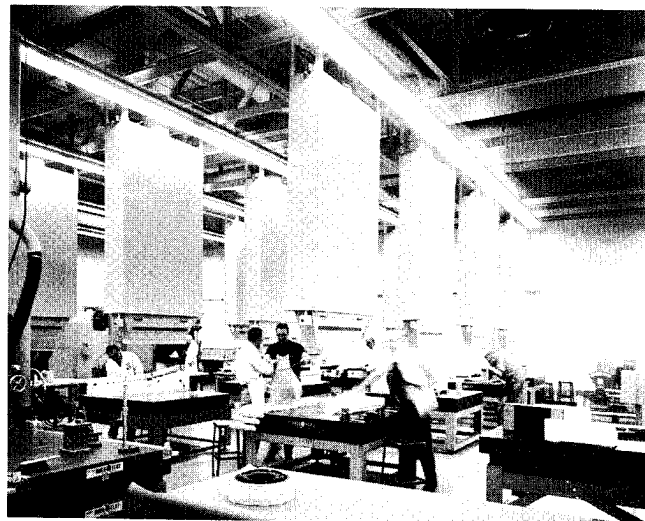
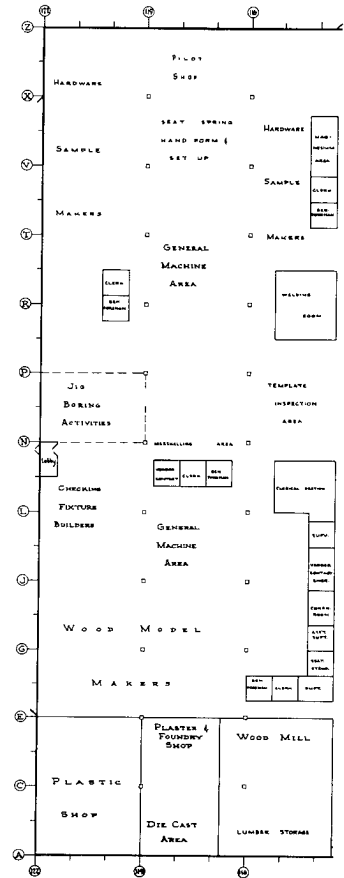

tops are made from granite which provides us with a flat and easily cleanable working surface.

We had many such people who, due to the limits of the hand method, produced very little at elevated costs.

This area looked attractive for changes.

Our first opportunity to do something about it arose when we became well established in our new quarters approximately 24 months ago. At that time we made our first attempts to put into operation a Guzman manufactured pump and spray gun. This equipment was bought to do away with the hand application of resins while the glass cloth was to give way to cut glass fibers applied from a specially constructed cutting device called a roving cutter.

We have slides to illustrate this equipment.

Slide 4 - Front View of Equipment

Following the flow of resin and hardener from left to right, we note the reservoirs connected to their respective pumps, screen manifolds, resin meters, heaters, pressure controls, and heated hoses. An interesting feature of this equipment is a

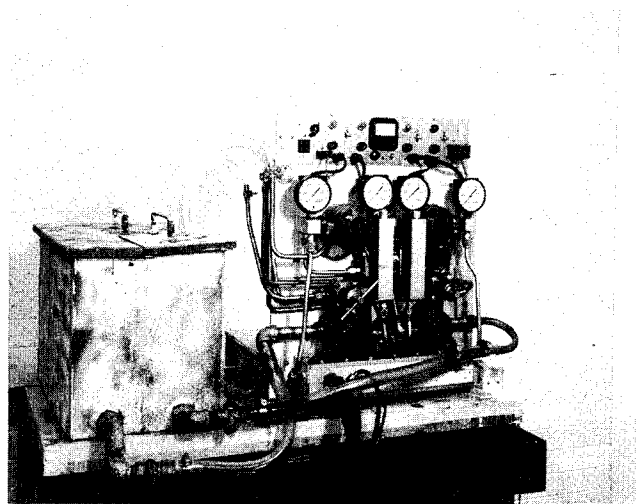

pressure sensing device which sends electrical impulses to a clutch in intensities proportional to any pressure differential across resin meter pump. The degree of clutch engagement determines the speed of the pump and hence the amount of volume pumped.

Slide 5 - Rear View of Equipment

We note a 1/2 HP motor driving two rows of gears through a gear reducer and clutch. The lower gear train, partially hidden by motor, is driving the resin and hardener pumps continuously while the upper gear train, speed-wise, responds to the variable clutch output governed by the pressure (or volume) requirements of the resin meter.

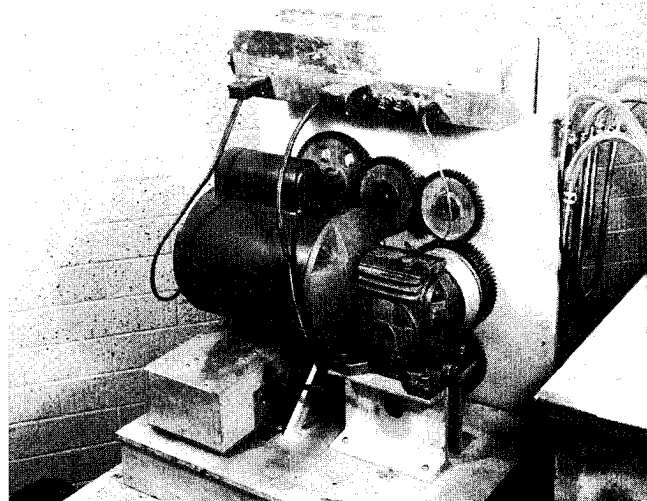

It is this upper row of gears the combination of which can be varied to furnish metering ratios from about 1:1 to 1:0.15 by volume.

Slide 6 - Guzmer Spray Gun

Simplicity of design, effective blending and easy maintenance are characteristic of this air-less spray gun.

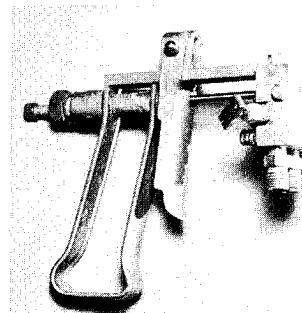

Of interest is the diagram showing the mixing chamber design marked by arrow 7. It is circular and tapers towards the orifice 6, which is .021" diameter.

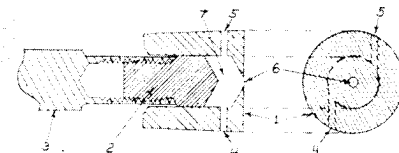

The mixing chamber is fed from the material hoses through orifices 4 and 5 which connect tangentially. The resultant swirling action produces high tangential forces responsible for the effective mix and good atomization of the resin and hardener.

A nylon plunger 2 actuated by a trigger closes and opens the inlets.

After months of work with the original equipment and materials recommended to us we came to the conclusion that neither the resins nor the pumping equipment (nor the people operating it) seemed to be made for each other, and many maintenance and operating problems just were not worth bothering with. As a result, we use the Guzmer pump only on occasions.

Efforts were made to obtain more suitable equipment and materials. We saw various pump designs and considered several spray guns. After giving due consideration to various features and how they might affect our particular working conditions we settled on what presents, in our opinion, a very satisfactory combination of tools. The succeeding slides will illustrate this.

Slide 7 - General View of Spraying Area

This view shows the relation of present spray equipment to spray area. The booth you see is 20 feet wide. The working depth to the water tank is 12 feet. To the rear one can note the water curtain wall.

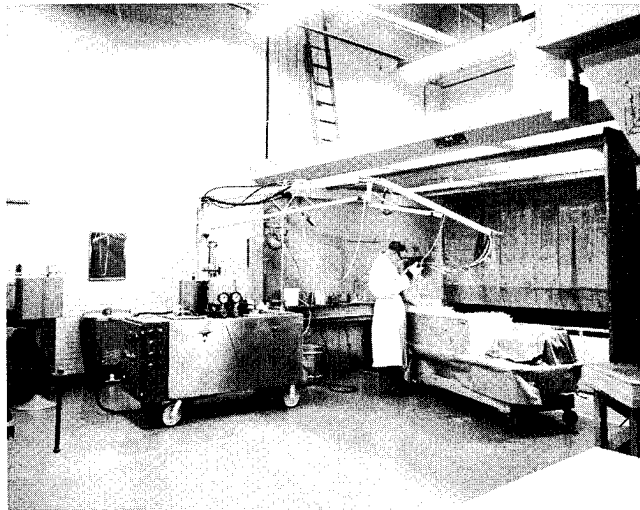

Two blowers set atop the spray booth provide the necessary ventilation.

A spray lay-up is being produced. The job is placed on a castered table. We have many such tables, varying in width and length. After the gel coat and the combination of lay-up coat and chopped fiber have been applied the table is wheeled aside to allow for the setup which precedes further coating. This interval is utilized to wheel into the booth the next job which may

again consist of a gel coat application or the application of the 2nd and 3rd combination of lay-up resin and chopped fiber. In this manner we can turn out a considerable amount of work at great savings in time to us.

The pumping equipment is set on casters for easy mobility. Atop the cabinet we had a boom mounted which carries the resins, compressed air and cleaning fluid to spray gun in separate hoses. The roving is stored above the cabinet and is pulled by the cutter along the underside of the boom.

Some of the important components of our equipment will be shown in our next slides.

Slide 8 - Front View of Graco Proportioning System

This is a close-up of the opened cabinet showing materials containers, the pumping unit, stirring devices, pressure indicators and temperature controllers.

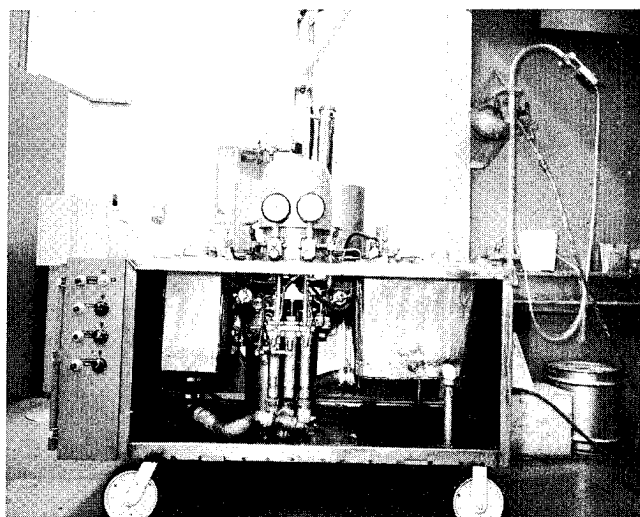

While we can maintain reasonably similar pressures in our supply hoses we have taken the precaution of installing one-way valves just ahead of the spray gun to avoid cross over of materials.

Cabinet and tanks are made from stainless steel.

The pumping unit is made by the Gray Company of Minneapolis. It has proven to be a trouble free and reliable performer in two years of continuous operation. Our air inlet pressure is 100 pounds and our fluid spraying

pressures are adjusted to about 700 pounds. Utilizing a Glass Craft made spray gun, about 2 pounds of resin and hardener are delivered per minute.

Resin and hardener storage temperatures are 140°F and 110°F respectively. It would be worthwhile to review the operation of our pumping system.

Slide 9- Schematic View of Graco Proportioning Pump

This schematic view shows the pump to be of the double acting positive displacement piston type. We note 3 pistons and their size is fixed to give us the proper volume ratio between hardener and resin. The outer cylinders are connected in parallel. All 3 pistons are yoked together and driven by one air motor. The materials enter at bottom through ball checks which prevent backflow on the down stroke. The cylinders fill as the pistons go up discharging the resins which have passed the check valve in piston on previous down stroke. On the downstroke materials below piston pass through upper check valve and are discharged into the system. The area above piston is 1/2 the area below piston.

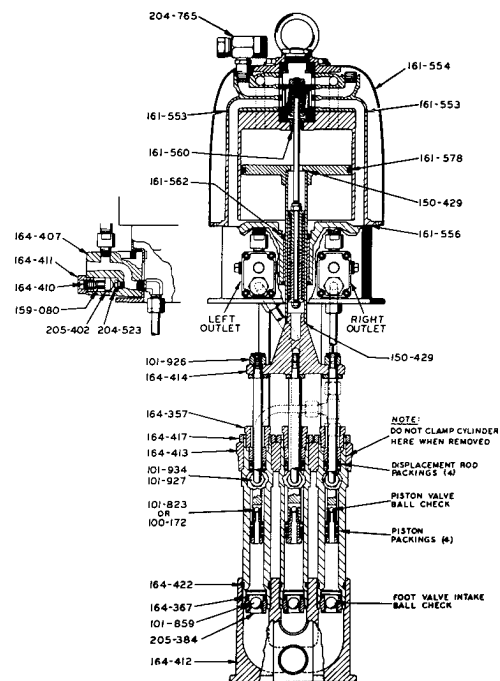

During the up and down movement of the air piston, a sleeve type air valve is actuated which is responsible for the reversal of the pump. Pressure relief valves are provided.

Slide 10 - Roving Cutter

After trying various designs we settled on a light weight Finn and Fram Chopper made in California. The length of the cut fibers can be varied from 1/2" to 4" in 1/2" increments. We are using 1" long fibers.

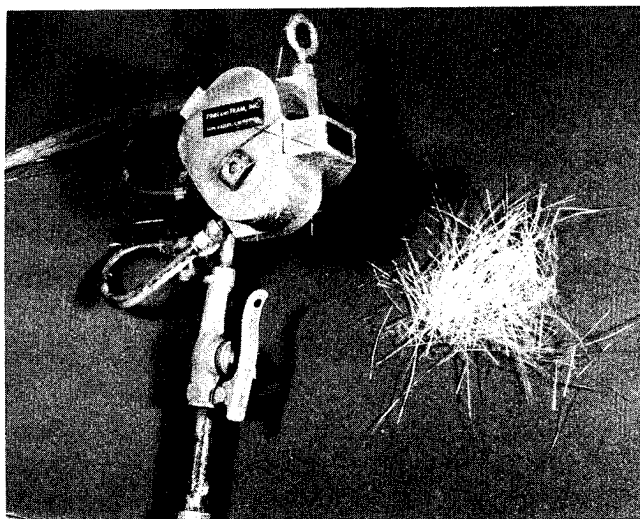

Ejection of fibers is clean due to the fact that the housing is pressurized. Servicing this device has been no problem. Perhaps not very clearly outlined is the electrical grounding wire to conduct away any static charges.

We buy glass fibers, or commonly called roving, from several suppliers. It is well understood that this material requires a surface finish called sizing which serves as coupling agent forming a mechanical bond with the glass and a chemical bond with the binder of the epoxide resins. This sizing is applied to each monofilament during the drawing process. It acts as a lubricant and as an adhesive holding the filaments together as strands which should wet easily. The roving which we use has 60 strands each having 204 filaments. Each filament is about .0002" to .0003" thick.

Three principal types of sizings are on the present day market, and they are designated chrome, silane-chrome, and silane. These designations refer to the type of coupling chemical contained in the sizing formulation - the chemical which provides the high strength abilities of the glass fiber. Chrome products, whether they be roving, mat, or woven materials, handle well, yet are lowest in physical strength. Products labeled "silane" produce laminates with the highest physical strengths; however, the glass fibers are difficult to handle in both the fiberglass and molding processes.

Silane-chrome products which we use are a good compromise between the other two products.

Slide 11 - Fiber Combing Device

During the early stages of the spray-up it developed that none of the cutter blades used held up for any length of time due to the stiffness which the sizing imparted to the fibers. We overcame this by running the fibers over serrated rolls as shown on this slide. This breaks up the strands and distributes the cutting load over a wider area.

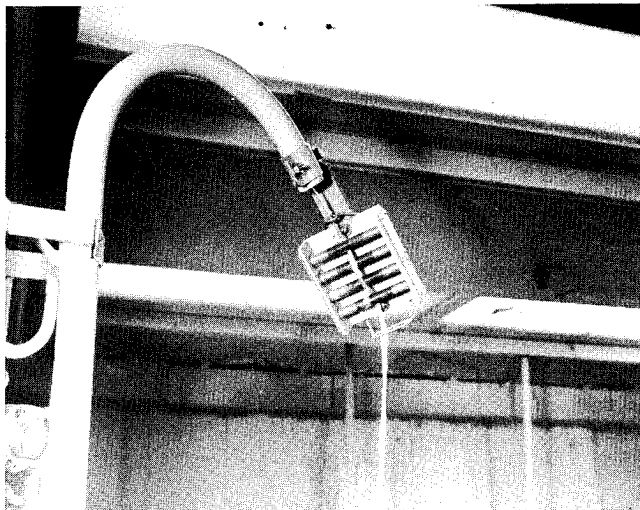

Slide 12 - Classcraft Spray Gun

This spray gun differs from the previously mentioned Guzman Gun in many important aspects. This one atomizes with air set at about 40 pounds. It also has a connection to a pressurized solvent system by which we can clean the resin and hardener passages at will.

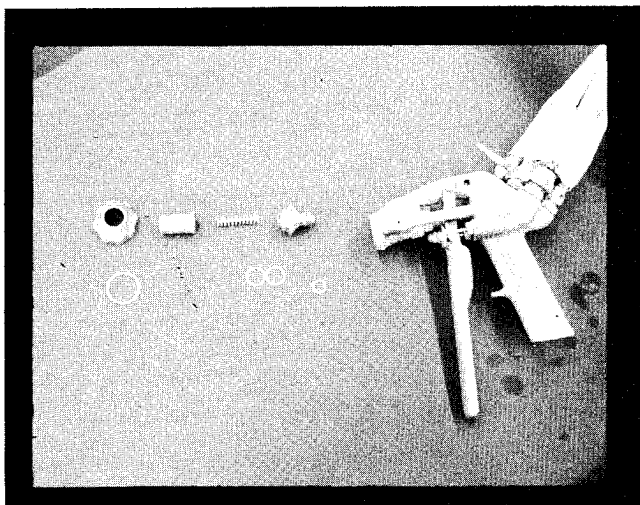

This gun does not produce a lacquer type mist pattern but rather a splatter. This is not objectionable as over-spray is cut down and most good resins have a natural leveling ability.

The blending of resin and hardener is accomplished in the forward portion of the gun by means of a grid which is 5/16" diameter x 1-1/2" long. There are 4 peripheral slots extending over the length of the grid. There

are 11 spaces where the grid is reduced in diameter to below the depth of the slot. Looking at it, there is an appearance of slotted discs mounted with spaces between them on a thin shaft.

Let us now follow a job from start to completion. It is well known that epoxy resins have outstanding adhesive properties. Therefore, release agents must be used to assure separation of the tool from the mold. To make a mold, wood, plaster, metal, rubber or plastic are used by us. In all cases, excepting plaster which requires a sealing lacquer first, we use a combination of wax dissolved in naphtha and a polyvinyl alcohol solution applied consecutively.

Slide 13 - Apply Wax Parting Agent

The wax, a product of the Salvador Company, is applied by brush. This is followed by a cloth wipe to assure uniformity.

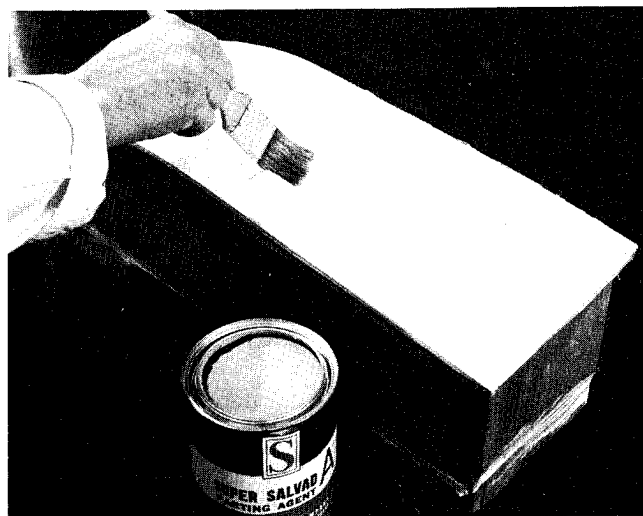

Slide 14 - Apply PVA Parting Solution

Immediately thereafter we spray the PVA solution. At this time we are using "Partall #10", but other and similar formulations are just as effective. Within 5 to 10 minutes the PVA solution has solidified and the tool construction can proceed.



Slide 15 - Application of Gel Coat

For our application we have found Hysol resin #4343 combined with Hysol hardener #3567 adequate. It brushes out easily, does not retain air bubbles and provides for a wear resistant surface which is easily cleanable. Good detail and reproducibility are characteristic of this

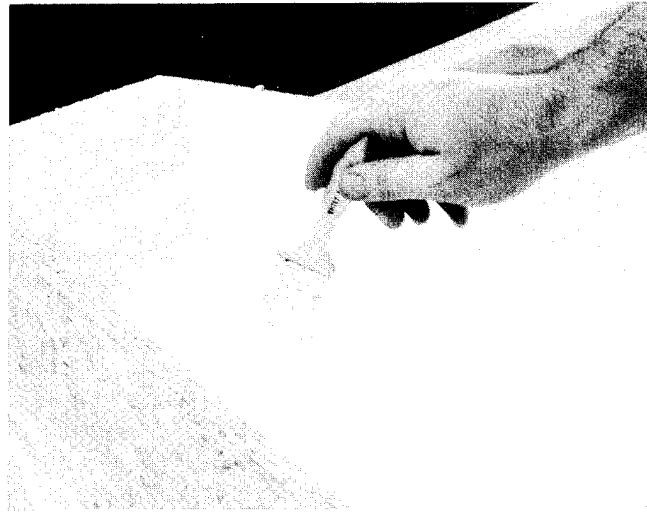

gel coat. Other similarly effective materials are available.

Subsequent operations such as the overall application of a pasty mixture of laminating resin, hardener and cotton flock and the actual lamination itself can be carried out within 15 to 30 minutes after the application of the previous coat.

Slide 16 - Tamping Glass and Resin Coats

The first laminating coat consists of an application of resin and hardener followed by chopped fibers which in turn are wetted by another application of resin and hardener. This is rolled down if conditions permit or tamped down by a brush frequently dipped in isopropyl

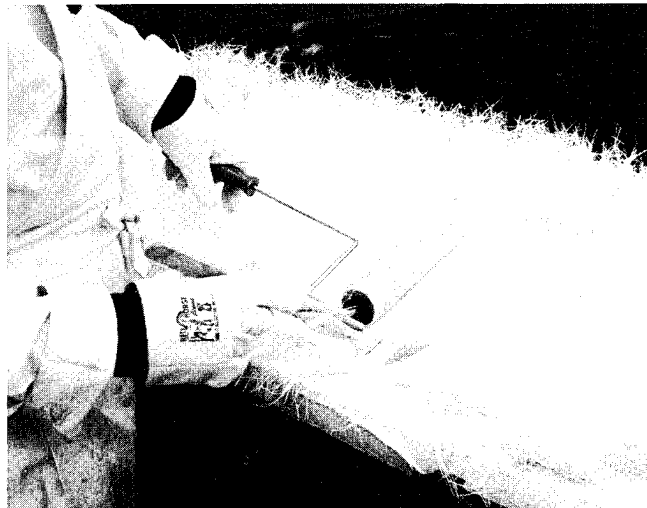

alcohol to avoid pickup of epoxy resins. Such a coat measures about 1/32" or more. After 10 to 20 minutes the first laminating coat is tackfree and subsequent laminations may be just like the first coat or it may be a double

coat consisting of a combination of resin, glass, resin, glass, resin. In case of such a multiple application tamping is always carried out on the resin following the application of glass, so that in this case we would tamp twice.

Slide 17 - Laminating a Structure

Eventually, 6 single coats are applied totalling 3/16". This represents our normal practice. You might be surprised to learn that this thickness would not vary more than 10%.

Glass fibers represent about 35% by weight of the sprayed up structure.

Slide 18 - Removing Overspray

Overspray is removed with a portable electric grinder utilizing a #36 grit wheel.

Slide 19 - Showing Stages of Completion

Eventually, we come to the stage where the structure requires reinforcement and its bases. Depending on the size and configuration we use non-metallic sheet stock of 1/4" to 3/8" thick

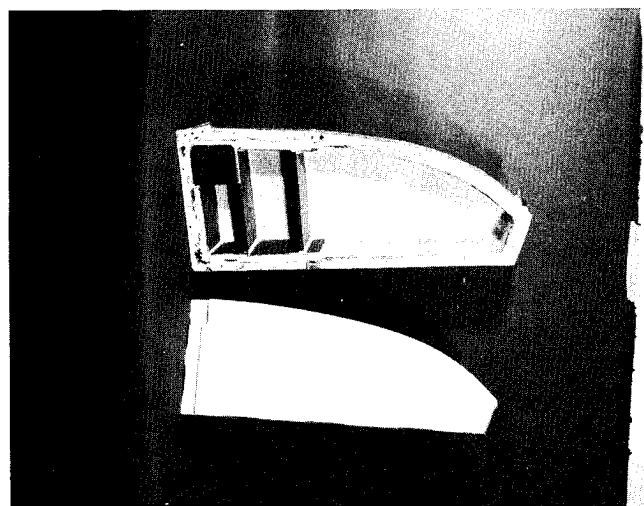
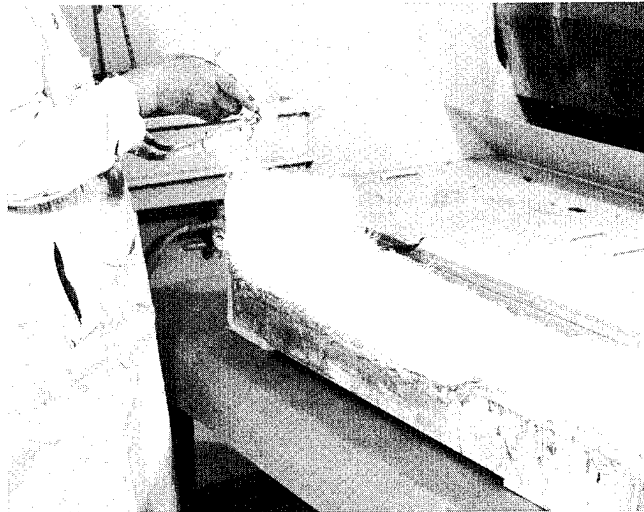

singly or in combination with plastic or metal tubing. Maximum adhesion between joints is essential. Therefore, all plastic joints must be sanded and metal joints must be free of grease or oil. As the bonding agent, we use our laminating resin filled to a paste consistency with cotton flock.

In this manner we also bond the bases, an example of which you can see on this slide. In our experience, a dimensionally stable, carvable material is essential. These requirements are met by synthetic formulations.

Slide 20 - Base Routing Machine

Bases of laminated structures are routed on this machine.

The equipment shown on this slide is mounted on a 4' x 10' granite table. The routing head can be raised to clear 42".

Ventilation is provided through flexible hoses as the machine travels over the stationary work.

The machine was built and assembled in our shops.

Now, an important word about the selection of resins and hardeners. We are concerned about potlife characteristics as determined by our scheduling requirements and our equipment. In the case of the former I have mentioned to you the curing intervals within which we wish to continue with our various laminating routines. We also require compatibility of resin and hardener and what we are and are not looking for is shown on the next slide.

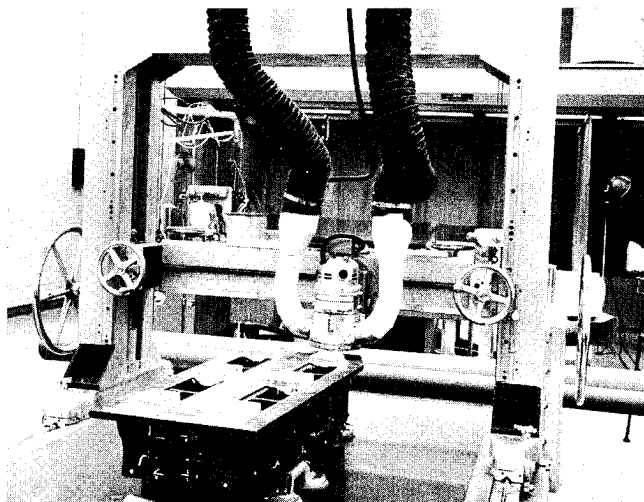

Slide 21 - Effect of Hardener
and Resin in Two
Competitive Systems

The exhibit on the left represents a combination of materials we have used for the last two years. To the right is a competitive system which we tried to develop as an alternate source of supply. We were led to make this check after we

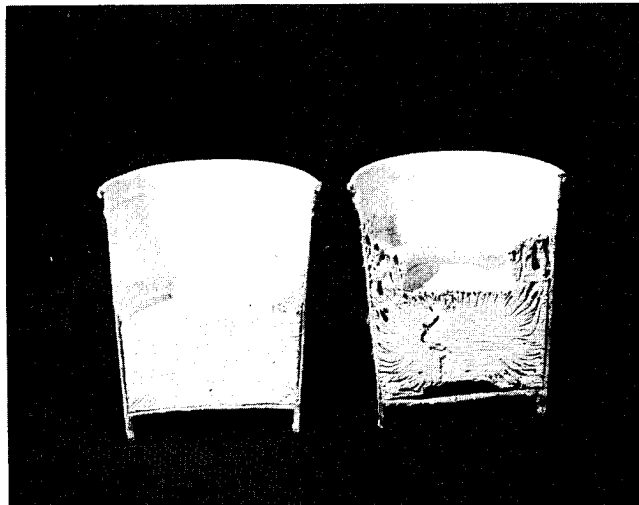

noticed an abnormal heat sensitivity in our heated storage tanks and some undesirable boundary conditions on the job.

Additionally we require the approved epoxy suppliers to furnish us materials which, in order to protect our equipment from clogging must pass a 100 mesh screen (.006" opening).

As I mentioned to you at the beginning, we have thought of quite a few applications which turned out to be extremely useful in our prototype work.

I would like to show you some slides.

Slide 22 - Vacuum Forming
Mold for Plastic Cover

This vacuum forming mold measures 30" x 70" and is 8" high. It was made from a male wood pattern shown in the next slide.

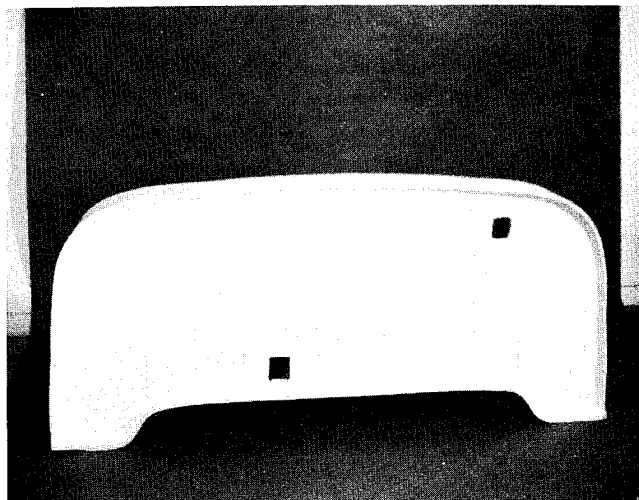

Slide 23 - Wood Pattern for
Cover Mold

Your attention is drawn to the plastic fence which served as a height gauge for constructing the mold sides.

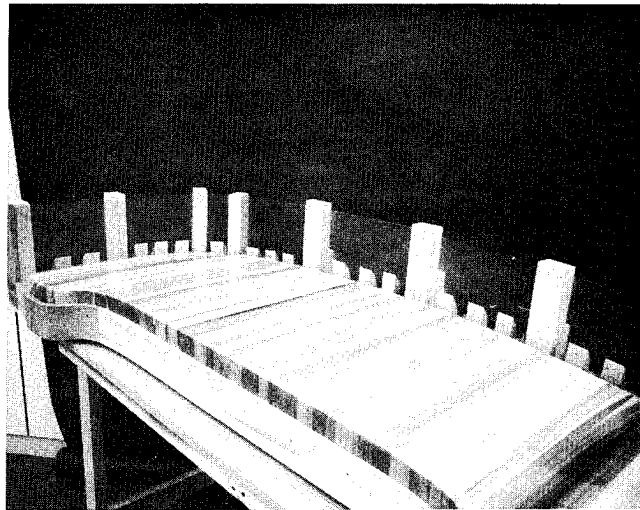

Slide 24 - Showing Underside
of Cover Mold

Reinforcements made from Panelyte sheeting 3/8" thick can be seen clearly.

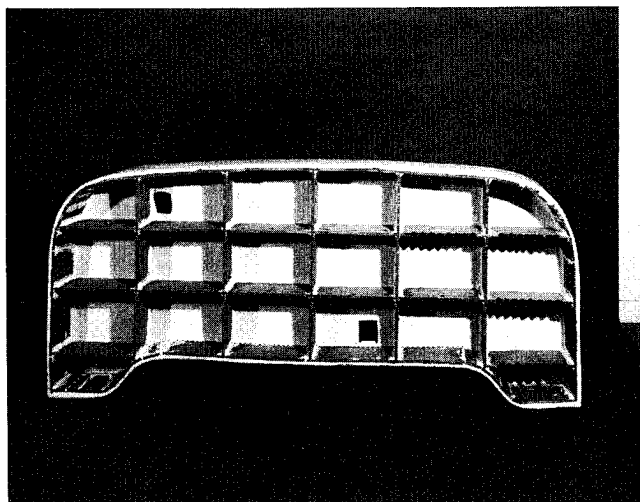

Slide 25 - Various Manufacturing
Methods for Wheel Covers

Three prototype manufacturing methods for 3 different wheel covers are represented on the right side of this display board.

Top Row: Electroformed over an epoxy spray-up matrix as shown on left upper side of board.

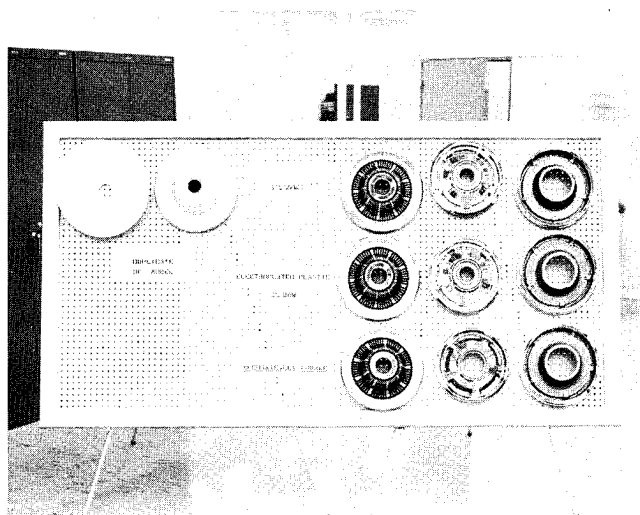

Center Row: Electroplated epoxy spray-up wheel cover.

Bottom Row: Conventional manufacture.

These are all appearance items and you could not tell them apart.

Slide 26 - Showing Backs & Front of Plated Epoxy Wheel Covers

It is particularly interesting to see the fronts and backs of sprayed up and electroplated wheel covers.

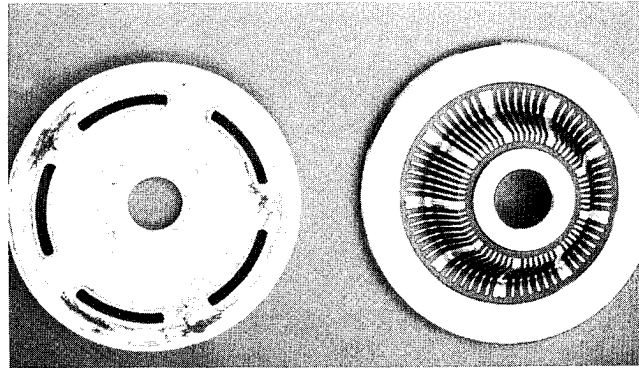

Slide 27 - Rubber Take-off and Plaster Form

The electroforming matrix pointed out to you in a previous slide was produced from male and female rubber molds. The latter was taken from the wood model to the left.

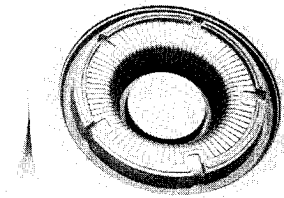

Slide 28 - Paint Mask

We have many occasions to furnish paint masks. The slide shows one such sample taken off from the prototype by the epoxy spray lay up method.

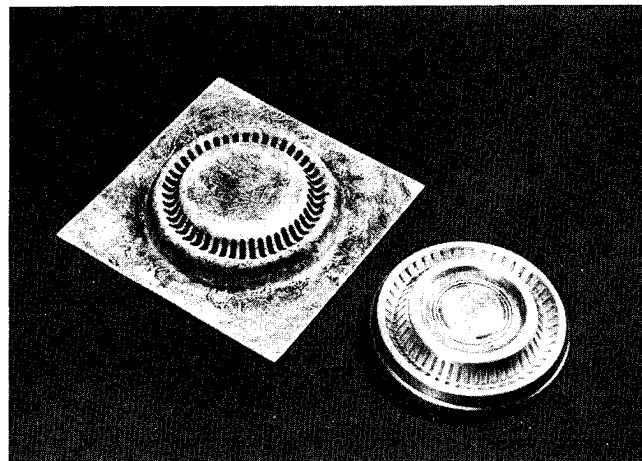

The slots corresponding to areas that are to be painted, were cut out on a milling machine.

In concluding this presentation to you I want to tell you that after much apathy and initial opposition from foreman and workers alike, we have today, their wholehearted support reflected in a quality job. We have considerably reduced our health problems such as skin disorders which plagued us when laying up by hand.

We have trained 6 people who are very proficient in the spray lay-up. But only one ever sprays at one time during his shift. While we have not done so yet, we think that with one man per shift we could fabricate numerous structures at the rate of about 3 tons per month.

Thank You

Section I

Bagging for Production

Perry Noblett

6303

BAGGING FOR PRODUCTION

Perry G. Noblett
Production Development
Engineer

Bell Helicopter Company
P. O. Box 482 Department 85
Fort Worth, Texas

[The process of bagging production parts for cure at room or elevated temperature, or for purpose of holding an assembly together for movement from one place to another is well known to many industries.

There are various materials available for the purpose - plastic films, such as Mylar (a polyester), Polyvinyl alcohol, Polyvinyl chloride, Polyethylene and Butyl or Silicone rubbers.

The choice of material may depend upon one or more of the following: Temperature of cure, configuration of part, length or number of the production run.

The method of applying and sealing the bag will generally depend upon the bag material and/or the part configuration.

Mylar and silicone rubbers have been used for cure and post-cure temperatures up to 500° F. However, the majority of ~~our~~ applications are in the range of 350° F.] For the 350° F. range, we have used all of the materials mentioned.

Polyvinyl chloride films 1 1/2 and 6 mils are used where radical compound contours are encountered for ease of gathering, whereas the wrinkles can be gathered to suit the fabricator.

The folds or wrinkles of the bag are usually gathered in areas where bridging could occur, thus preventing a poor quality of lost assembly.

The film materials are easily spliced together by heat seal to provide wider blankets. Where small parts are encountered (18" x 18" or smaller), the film may be folded, heat sealed on two sides, then the tool with the part in place slipped into the bag and the opening heat sealed.

Heat sealers are available in many forms and models, one of which will be shown in the example slides which follow this paper.

Shrink tape may be used with small parts such as ducts. The tape is wrapped around the part with 30% overlap. When the part is heated, the tape shrinks. No bleeder is necessary with this application.

Butyl rubbers are used for flat or gentle contoured surfaces and are easily applied and removed. The butyl blankets are used many cycles, whereas the films in most instances, may be used only once.

A certain labor savings is realized in the application of reusable blankets due to their ease and rapidity of installation.

Butyl rubber blankets usually take a "set" to the configuration of the part after two or three cure cycles. Like all rubbers, the butyls will continue to shrink slightly as long as they are used. Blankets should always leave allowances.

Silicone rubbers are the most expensive of all the materials in initial cost, but are so unaffected by heat that in the long run may prove to be the cheapest. These rubbers do require careful handling to prevent tearing or cutting. Silicone bags are easily repaired with single component silicone paste.

The most common methods of applying bags are the following:

- "C" clamps

- Rope seals

- Zinc chromate paste (high temperature resistant)

- Heat seal

- Hose clamps

Bleeder materials between the part and the bag are generally necessary to prevent local "seal off" and provide equal pressure where vacuum is utilized. Bleeder may be necessary for the escape of gasses created in the cure of some adhesives.

The following materials may be used as bleeders:

- Glass cloth

- Coarse weave cotton cloth

- Screen wires

- Roving strands

- Grooves molded in the rubber blanket.

We require a minimum of twenty-eight inches (HVIG) mercury on all of our bags before a part is placed in the oven or autoclave for cure.

To locate any leaks that may be indicated by the failure of the gauge to read 28 or more inches of mercury, the shop is provided with a leak detector.

The leak detector is a battery powered sonic device with a microphone probe which points out the leaking spot from the air hiss. Background noises are filtered out by the device.

The application of the leak detector is shown in one of the slides.

The following slides will illustrate the bagging materials and their application. We will discuss the slides individually to explain the reasoning for the method used.

Section J

Simplified Tooling with Silicone Rubber Molds

John Pletzke

SIMPLIFIED TOOLING WITH SILICONE RUBBER MOLDS

John V. Pletzke, Supervisor
Market Development
Dow Corning Corporation

H. A. Smith
Application Engineer
Dow Corning Corporation

Approximately twenty years ago, the first commercial silicone was introduced by Dow Corning in the form of a grease-like electrical insulation compound. This product laid the foundation for an entirely new industry which was to follow.

Among the many diversified products which were subsequently developed is a two-part TRV silicone rubber compound. This revolutionary new product was an entirely new concept in the field of silicone rubber. Supplied as a low viscosity fluid with excellent flow characteristics, with the addition of a catalyst it will vulcanize to form a rubbery solid at room temperature without the aid of heat or pressure.

Initially developed for high temperature potting, caulking, sealing and encapsulating applications, more recently their application versatility has been extended into the field of flexible mold-making. Because of the emphasis that has been placed on the use of these materials in this field, a new family of flexible mold-making materials specifically designed to accommodate a wide variety of handling techniques and casting materials has been developed.

What makes these materials desirable for mold-making? Not one, but the summation of nine outstanding characteristics contribute to their versatility.

1. Simplicity of use
2. Faithful reproduction of fine detail
3. Flexibility
4. "Built-in" or natural release characteristics
5. Thermal stability - remains stable to 600°F
6. No exotherm
7. Application versatility
8. Vulcanization times of from a few minutes to hours
9. Non toxic

To further explain the abilities of these products, we will elaborate somewhat on each of them.

1. Simplicity of use - Elaborate mechanical equipment is not needed. You simply need the following tools:

- a. Paper cup

- b. Spatula
- c. Simple weight device
- d. Silastic RTV rubber

2. Faithful reproduction of fine detail - Because of their excellent flow characteristics, these materials have the ability to reproduce intricate detail.

3. Flexibility - Due to the rubbery nature of the vulcanized mold, patterns and prototype parts of complicated configuration may be easily extracted from the molds.

4. "Built-in" of natural release characteristics - Since RTV silicone rubber will not adhere to most materials, parting agents are not required when casting over patterns and release agents are not necessary when casting parts into the finished mold.

5. Thermal stability - remains stable to 600°F. - will accept casting materials in the range of 600°F and will also remain flexible to -100°F. Thus, the exothermic heat given off by epoxy and polyester resins will not have any detrimental effect on the mold.

6. No exotherm - Opposed to epoxy and polyester resins, the RTV rubbers do not give off any exothermic heat during vulcanization and accordingly may be cast over low melting patterns.

7. Application versatility - They can literally be applied to objects of unlimited design.

8. Vulcanization times of from a few minutes to hours - Vulcanization rates and working times vary, depending upon the particular Silastic RTV rubber selected.

9. Non-toxic - May be used without fear of breathing harmful vapors or irritation caused by skin contact.

There are several types of room temperature vulcanizing silicone rubbers available. However, handling properties, working time, cure time and other characteristics vary from product to product. The material used should be chosen on the basis of the job to be performed. The products available, vary according to viscosity, durometer, working time, vulcanization time and thick section curing ability.

PROCEDURE FOR MAKING A TWO-PIECE MOLD

I. The initial step is to weigh out the proper amount of material required to produce the first half of the mold. One cubic inch of cured rubber will require approximately 20 - 25 grams of base material.

Remember to deduct the space that will be occupied by the pattern.

II. After the mixing of the catalyst into the base material, it is recommended that it be vacuum de-aired due to the incorporation of air during this process. This will insure that a void-free mold is obtained and that no air is entrapped on the surface of the pattern. However, other techniques are available; such as, brush coating and pressure casting.

III. When these simple procedures have been completed, the fluid silicone rubber is now ready for pouring. A lay-up box may be constructed of a porous material such as cardboard or wood. The pattern is set in place and the catalyzed rubber is cast.

IV. After vulcanization has been completed, the mold is removed from the lay-up box and inverted. A parting agent is applied to prevent adhesion of the mating surfaces of the mold and the second half is cast. This completes the process for making a two-piece mold.

V. Since the RTV silicone rubbers possess the inherent properties of flexibility and "built-in" release, prototype parts may be easily cast. The technique for casting will depend upon the shape of the part to be reproduced. This will also be a determining factor in the location of the pouring and vent sprues. It is recommended that the mold cavity be filled from the bottom up. This will prevent the entrapment of air in the finished part.

The application versatility of the Silastic RTV system is virtually unlimited. The use of them is perhaps limited only to the imagination of the mold fabricator. They can be applied to objects constructed from numerous types of materials and designed with unlimited configurations. Professional results may be obtained easily and inexpensively through their use.

They may be used successfully for such applications as:

1. The Shaw Process - as an intermediate step to a metal part.
2. Prototype parts
3. Low volume production operations
4. Centrifical casting of polyester parts
5. Candle molds
6. Toy design
7. Replacement of non-standard parts
8. Electroforming of nickel and copper molds
9. Prototype blow molds
10. Hand lay-up or gel coat applications

Since their entry into the field of plastic tooling, RTV silicone

rubbers have reduced tooling costs, simplified complex techniques and have made possible the reproduction of the minutest detail with little effort on the part of the mold maker. Although still in their infancy, the benefits derived from their use are sure to influence the future of this vast industry of plastic tooling. Already, many accomplishments have been made possible which could otherwise not have been performed. Their continued use will undoubtedly open new in-roads for industry and unleash the ingenuity of today's designers.

Section K

Fabrication of Plastic Models and Fixtures

Arthur Wright and Sam Callis

"FABRICATION OF PLASTIC MODELS AND FIXTURES"

Arthur Wright
Sr. Project Engineer
Burnswick Corporation
Muskegon, Michigan

Sam Callis
Chief Tool Engineer
Brunswick Corporation
Marion, Virginia

Why should we use plastic tooling?

The answer is simple economics. In the highly competitive fields of today's industry, the jobs go to the manufacturer who can keep production cost down and at the same time maintain quality in the product.

In the breakdown of manufacturing cost tooling can be a major consideration.

Here is where the intelligent use of plastics can offer substantial benefits. It should be understood however, that plastics are not the magic answer for all tooling problems. Plastics are engineering materials possessing certain properties which, if properly applied, can do a job more efficiently than other materials. They should be evaluated carefully and objectively from an engineering standpoint.

The reasons plastic tools have become an important and one of the major tooling medians are:

1. The ability of the manufacturer to meet shorter delivery schedules by having faster tool delivery.
2. Lighter weight and lower cost tools.
3. Ease of duplicating tools for increased schedule.
4. Tools which can be modified for engineering changes and/or repaired easily.
5. Tools that resist normal corrosive action.

The four principal plastic tooling resins used in today's tools are: epoxy, phenolic, polyester and ethyl cellulose.

The pictures and samples you see here were made using epoxy resins, these are thermosetting resins produced by the reaction between epichlorohydrin and bisphenol and are cured with amine agents.

The advantages of using epoxy materials for tooling are:

1. High dimensional stability.
2. Low shrinkage
3. Excellent wetting and adhesion ability
4. Room temperature curing

The disadvantages are:

1. Poor temperature resistance - the heat distortion point for R/T cured epoxies is 180°F. to 200°F. Given an oven cure of 300° to 350°F. will increase physical properties 20 to 30%, and this is important to keep in mind when using epoxies for deep draw or other forming tools where you would get a large amount of friction generated heat.
2. Toxicity - the amine hardness may cause dermatitis to those who are allergic so adequate ventilation and proper protection must be provided.
3. Cost - epoxies are the highest cost of any of the tooling resins.

In getting to the actual fabrication of tools, there are two more-or-less standard methods of starting. Number one and probably the most common is direct casting or laminating from wood or plaster models.

Number two is to use a template set up with rough build-up under structure and a finish coat of splinning plastic.

One of our recent jobs at the Muskegon Defense Division was the manufacture of several 30 and 40 foot diameter parabolic reflectors with a final assembly tolerance of $\pm .010$.

The 30 foot diameter reflector was constructed of an inner ring of twelve 30° honeycomb panels approximately 6' -0'' in diameter assembled and the outer panels consisted of 24, 15° segments that were about 12' long.

We determined that as most of the tooling required was of male configuration, that a male master would be required.

Our first step was to make a lofted steel master female template, then optically setting a metal post in a vertical attitude on a surface plate, and attaching the metal template to the focal point or center of revolution. We then used plastic tubing, boarding and laminate frame work to build up to within about 1/8'' of the contour as given by the master template. Then splinning plastic was applied and the final contour and was swept in with the master template. Using both optices and feeler gages, we were able to hold the contour to within $\pm .005$ of the required theoretical contour.

The second step was the manufacture of a female tool we call a blue block. After preparing the master surface, a gel coat was sprayed on, and using 181 glass cloth, we hand laminated to a thickness of 3/8 to 1/2 allowing time lags between every 4 or 5 layers of cloth for the

resin to kick over and allowing the exotherm build up of heat to dissipate. A welded steel tubing backup structure that had been normalized and sand blasted was attached to the laminate, this then became the control tool for making the male aluminum bond fixture, and the rest of the family of epoxy laminated tooling, the consisted of routing fixtures for the skins and final inspection fixtures for the bonded assemblies.

One of the methods we use at our Marion, Virginia facility for making laminated molds with no gel coat is:

After the model has been prepared and the release applied, the mold is fabricated as follows: brush on a thin coat of laminating resin, apply one layer of 181 Volan A cloth, making certain that there are no wrinkles in the cloth and that it is completely wet out by the resin. Now four layers of #1000 Volan A cloth are added. (This cloth can either be impregnated as it is applied or pre-impregnated) after this thickness is built up apply a dry layer of 128 unfinished cloth for a peel ply. Apply a vacuum bag and squeegee the laminate to eliminate excess resin and any air present in the laminate. This portion of the mold is now placed in an oven at 150°F. for four (4) hours, then gradually raised to 200°F. for one (1) hour then to 250°F. for one (1) hour. The laminate is now allowed to slowly cool to room temperature. The vacuum bag and the peel ply is removed and any glazed areas are scuff sanded to insure a good bond. Brush a thin coat of laminating resin over the entire surface and apply additional layers of #1000 Volan A cloth to give a total laminate thickness of 3/8 of an inch. (Again this can be either impregnated as it is applied or pre-impregnated.) This additional laminate is covered with a peel ply of 128 unfinished cloth and vacuum bagged and cured as before. After the laminate has cooled, the bag (not the peel ply) is removed and the backup structure is fitted to the mold. This structure can be either high temperature tubing or laminated cured panels. After the backup structure has been fitted to the mold, it should be tied together and run through a cure cycle to eliminate any possible stresses. While the backup structure is curing, the peel ply can now be removed and any glazed areas scuff-sanded. After curing, the backup structure is positioned on the mold and tied in with two (2) or three (3) layers of cloth with a tubing backup structure. This tie-in need not be 100%, rather it should be made with six (6) to eight (8) inch wide cloth long enough to go over the tubing and extend six (6) to eight (8) inches either side onto the mold surface. If laminated panels are used, they should be "floated" onto the mold surface using a paste made from laminating resin and chopped glass fibers then tied

in with six (6) inch wide cloth so that three (3) inches are on the panel and three (3) inches are on the mold surface. The entire structure is now ready for the final cure which is 150°F. four (4) hours, 200°F. one (1) hour, 250°F. one (1) hour, 300°F. three (3) hours, 400°F. one (1) hour. After the mold has been allowed to cool, it is then removed from the model and is ready for production.

Here are some of the various programs in which Brunswick has used plastic tooling:

MUSKEGON FACTORY

B-52
Engine Nacelles
E2A Dalmo Victor Rotodome
30 and 40 foot parabolic reflectors
MPQ 32 reflectors

MARION, VIRGINIA

Telephonics Buoy
707 Vertical Fin Tip
F-106 Vertical Fin Tip
C-141 Nose Radome (2)
C-141 Tail Cone
C-130 Doppler Radome
727 Fairing Panels (2)
880 Nose Radome
F-101 Vertical Fin Tip
F8U Nose Radome
University of Denver Antenna Cover
C-130 Chin Radome

Section L
Pattern-Making in Foam
H. F. Shroyer

PATTERN-MAKING IN FOAM

H. F. Shroyer, Vice President
Full Mold Process, Inc., Parkridge, Illinois

MATERIALS:

Wood, metal, plaster and plastic have been used for many years in the making of patterns for the foundry trades. Only recently a new material has stepped into the picture to confuse the pattern-makers just a little more. Foam plastics is the critter!

Foamed plastic is new being generated in several different forms, using several different techniques. At present, the most commonly used is classed in the expandable polystyrene plastic category. This material is made from Benzine and Ethylbenzine. The combination of these ingredients, plus what is known as a propellant or blowing agent, is produced by three major plastic raw material suppliers and sold to the plastic molding trades in a bead form. Some of the trade names under which it is sold are Dylite, Pelaspan and Uni-Crest.

The raw material looks much like sugar when it is received by the foam molder. There are several screen sizes much like screen sizes in sand, from fine to course. Before molding, this material is expanded to a desired density in a machine called a pre-foamer. Molding machines used by foam molders vary in sizes and types depending on the products they specialize in molding. Molded shapes are produced in mass production from plaster cast aluminum molds. Products familiar to most of the public are: ice buckets, ice chests, swim boards, boats, display backgrounds and packaging inserts. As the Full Mold Process grows, high production patterns will be made by this process.

The product we are most interested in for this session is the bead board or block. High production techniques are used in molding this block, also. The machine or mold has been designed especially for board production. It is made for a specific board or block size and in most cases cannot be readily changed to make a different size. The machines are manufactured to molders specifications and are made in Germany, Switzerland and the United States.

Different molders have different sizes and densities available. Blocks run from 4 ft. x 8 ft. x 1/2" thick, to 4 ft. x 8 ft. x 17" thick. Other sizes go as high as 8 ft. x 20 ft. x 10" thick. There are many sizes in between. From these blocks most molders slab out boards of various thicknesses. Densities of from .9 lbs. to 1.75 lbs. per cubic ft. are common. Some use band saws to cut the block. This leaves rough, dusty surfaces on the material. Other molders use a hot wire

cutting machine which leaves a semi-rough but sealed surface. Some molders have both surfaces available and even go further to sand the surface with large sheet sanders. This method provides boards held closer to consistent thicknesses or tolerances.

Most of the board and block materials on the market today are made for the insulation trades. The size of bead used is on the large side and tends to give rough surfaces when cut. This roughness is caused by the openings left between the large beads during the molding operations. Surfaces of this type will create exactly the same effect on castings made from patterns of this type material. Waxes have been and are being produced to be used as fillers to fill surfaces where better finish is required on castings.

Even further developments are taking place in the foam producers plants. Smaller or finer screened beads are being used to create boards or blocks or sheets with finer finish characteristics. Some molders are adding finishes to the board in unique fashions to give us smoother surfaces. With these smoother finishes it is not necessary to fill the surfaces with wax to get better casting finish, or if so, much less wax is used.

Due to its combustibility, precautions should be taken about smoking in the fabrication and storage area. If reasonable safeguards are provided and proper precautions are practiced, these materials can be handled and stored safely. The effect of extended exposure to gases given off by the material during fabrication relating to personnel health is insignificant to non-existent. Polystyrene dust, although rare, can be inhaled, but it seldom reaches further than the bronchi. No harm from breathing dust has been reported. Skin tests of the individual components of polystyrene indicate that no component of expandable polystyrene is a skin irritant. It should be noted that no hernias have been reported from lifting this material.

Other characteristics of the materials tend to fit specific needs. Some materials are produced with additives to form a self-extinguishing feature. This material is usable for foam patterns also. When ignited, the material will continue to burn as long as a flame is supplied. As soon as the flame is removed, the material will extinguish. This material can meet UL codes for construction. The rate of water absorption of expanded polystyrene is almost nil, 1/2 of 1% of volume when totally submerged for 1 year. There is some warpage of boards when the material is improperly cured or when shipped green. Most warpage of board can be reduced or eliminated during fabrication of patterns. During the manufacturing operation, a shrinkage of approximately 1/16" to the foot takes place immediately. This

has been allowed for in the size of the mold. Another 1/16" per foot shrinkage takes place in approximately 90 days after manufacture.

PATTERN FABRICATION:

Most of the present machines used for making wood patterns can be utilized for working with foam. Band saws with fine teeth do a good job of cutting. Smoother finishes can be attained with scalloped edge saw blades. Simply grinding the teeth off of a standard blade and sharpening to a razor edge gives excellent finish. Experiments are being performed using Teflon-coated blades to eliminate a build-up of plastic on the sides of the blade.

High-speed routers, drill presses, milling machines, etc. are now used to hog out or contour shapes in foam. The use of thick blocks of this material reduces or eliminates the laminating of boards to create heavy sections. Making of a box shape can be done by machining out the center of a block cut-to-size. This gives radii or fillets in the corners the same size as the cutter used, so no additional fillets are required. The ability to poke sharp, thin tools, such as sharpened hack saw blades through the walls of foam allows the finishing of the bottom of a hole to be performed quite easily. The slot made by the sharp tool can easily be sealed by the use of wax or even a piece of transparent tape. Machining holes through a board of the proper thickness and the applying of a lid or bottom to the opening is also quite simple.

Hot wire cutters are available and do an excellent job of contouring in foam. Cutting radii too short for wide band saw blades is practical with hot wire cutters. To get to inside cutting, the simplest way may be to cut through the wall and merely re-seal the saw mark after the saw is retracted.

Sanding discs, filers, sandpaper sticks and other types of sanding methods can be used. Care should be taken when sanding as the material works quite fast and also, being so light, will grab or flip or float from air currents.

Blocks of foam may be adhered to face plates, allowed to dry and turned on a lathe. Very sharp thin tools again should be used as a chisel type action is not acceptable in this material. Pushing a cutter straight into the material, such as a chisel motion, pushes the individual beads ahead of the cutter and causes a tearing action. Slicing is the best way to describe the motion best suitable to attain a good finish.

PATTERN ASSEMBLY:

Many special glues or adhesives have been developed for use in foam. Special contact glues are now available that give almost instant, complete bond. Care in selection of adhesives is a must. Many adhesives have chemicals in them that will etch or eat the foam. Some react instantly, others react over a longer period of time, and a large parting or separation between pcs. becomes apparent. There are water based adhesives available. These take longer to dry, but will pass certain fire, storage regulations.

Application of adhesives is quite important in the end results of a casting. Instead of applying adhesives over a complete area to be glued, a perimeter application may be quite sufficient. If more adhesive is needed it should be applied in patches or X's. If too much adhesive is used, and the improper kind, inclusions can be noticed in castings. Some adhesives will not burn and patterns made of these may reflect a separation at the glue line, in the casting made from these patterns.

Clamps can be used to hold a pattern together or weights may be used where possible. Good contact glues will eliminate most of this.

In some cases, dove-tailing, rabbiting and fitting will eliminate the need for adhesives. This material is such that a plug a little larger than the hole can be forced in and will grab and stay.

Small wires, metal pegs, nails, etc. have also been used. This is OK as long as they can or will be consumed by the molten casting charge.

RELATED PRODUCT DEVELOPMENTS:

Many supply companies are preparing themselves for the expansion of this process by creating new products allied with pattern-making and casting in foam. Special low density wax fillets have been produced for applying directly to a foam pattern. Their use should be studied carefully in relation to the cubic volume used versus the cubic content of foam. Too many wax fillets on a small pattern can create inclusion problems in the end casting. Their application to foam is quite simple, the heat of the hand is enough to allow it to be pressed in place.

In place of wax fillets of larger sizes, you will see standard molded foam fillets on the market soon. Other molded foam shapes soon to be available or already available, are, molded blind risers, standard bosses, molded runner bars, elbows, cylinders or sleeve, etc. Bar stock of different sizes may also be offered.

Coatings or washes, formerly applied to the sand to prevent burning, have been developed specifically for application to the foam pattern. This operation is usually performed in the foundry at the same time runners, gates and risers are applied.

Urethane foams which will also dissipate on contact with a molten charge have been developed. A unique application is being made by one of the largest motor car companies. After making a plaster replica of the parts of an automobile body, such as a door panel, a mold release agent is applied to the plaster surface. A frame is made of wood to fit around the plaster and form a box. Into this box, the urethane foaming agents are poured and allowed to foam in place. Upon removal, the foam has taken on the shape of the die needed to form the sheet metal door panel. The back of the foam is dressed off smoothly and the edges trimmed and blocks of polystyrene assembled to build-up the rest of the pattern for the die. Finishing tolerances are allowed in the pattern for kettering. This eliminates many steps formerly used to attain the required contouring in a wood pattern.

PRODUCT OR PARTS DESIGN:

Due to the fact that a foam pattern is not removed from the sand during the molding operation, the lid is off design. Visualize if you will, a large casting with many core boxes required and the time involved in just figuring out where to part the pattern and how to apply core prints. This involves thinking in reverse in many places, and also generates many errors and correction requirements during the transposition from a part print to a pattern.

Visualize how the transposition in foam to an exact replica of the part print itself, with shrink tolerances added. No core prints, no core boxes to make, no parting line problem, no draft allowances, no bumping problems to allow for in pulling the pattern, and no core shift allowances need be considered as there are no cores to shift.

With this thought in mind, designers and engineers can begin to design additional coring at no extra cost, in fact to reduce cost by reducing casting weight. Back drafts, costly additional extensions, bridging effects and many others can be designed for additional advantages that previously cost too much to core.

In some cases, standard core stock, such as stick cores can be incorporated in the foam pattern. Inserts such as pipe, tubing, chills and alloy faces can be added as the pattern is made.

Combinations of standard wood patterns with foam loose pcs. in place of cores also add additional advantages. Foam pcs. added to the

wood pattern by pins, reverse prints or merely placed on the pattern have been used. After the wood pattern is withdrawn, the foam pc. remains in the sand and is dissipated in the same manner as a full pattern of foam.

Patterns can be made in sections which may be disassembled to facilitate molding. Large patterns have been made with trap doors, or removable sections so a man can get inside to ram up inner sections. These sections are re-assembled, the parting lines taped or glued and the ramming operation continued. Others have been made in halves for cope and drag ramming and ease of rollover, etc.

TRANSPORTATION:

Foam, being so light and fragile, creates some problems in shipment. Patterns made of this material cannot be bounced around, slid or bottom loaded like wood patterns. Some patterns have been made so large they have to be split and shipped in sections. Castings as large as 30 tons have been made in the Detroit area and the patterns for these would not go through the pattern shop and foundry doors. Even a pattern this large has at maximum, 200 lbs. of foam, 4 or 5 lbs. of adhesive and at most could weight 250 lbs., including fillets, wax coatings and all. The need for cranes to handle this kind of pattern is limited.

Freight cost per lb. on foam block and board is such that it warrants finding the closest sources possible. Many pattern lumber dealers are beginning to handle this material.

RESULTS:

The next question in mind may be, "now that we have a pattern. what happens"?

If the pattern is made of the right materials, to proper specs., and the foundry molds it properly with the proper gating, risering and coatings, the chances are better for getting a good casting the first time than using the conventional methods. The pattern is reproduced in metal almost exactly, with defects, finishes and shapes appearing as they were in the pattern. There will be no flash from core setting or parting lines, no drops, or defects from loose sand or core shift. In most instances the gates and risers are removed and ground and the casting is blasted and chipping required. Center lines, if made on the pattern will show on the casting.

Due to a hydrostatic head pressure maintained while pouring, and other favorable elements created by the process, the perlitic structure

of the metal is improved. Ten to fifteen points of Brinnell hardness increase have been noted in most instances in gray iron. The process has been used for aluminum, brass, bronze, steel, gray iron, Ductile, malleable and other types of metals.

Machining characteristics show such improvement as explained by operators and supervisors, that foam made castings hold preference over conventional cast parts in shops where they are used. This process is not a cure-all and is not claimed to be. Where practical, its use can create savings in pattern costs, foundry costs and machining costs. The one great thing that will be accomplished by this process is to bring weldments back into the foundry. Many castings have been made which are weldments, and at definite savings to the users.

Please; do not merely substitute foam plastic for wood. The advantage of this step is small compared to the use of ingenuity.

LICENSING:

The novelty of the patent is such that the control granted is at the foundry level. The molding and pouring of the mold is licensed by an initial license fee and royalties on a weight of castings made basis. Pattern shops or the casting purchaser are not required to take license, unless they have or own and use a foundry to create the casting.

Section M

The Use of Plastic Tools in Forming
Prototype Sheet Metal Parts

F. S. Vanker

THE USE OF PLASTIC TOOLS IN FORMING PROTOTYPE SHEET METAL PARTS

I. Introduction

II. Hammer Forms

A. Wood Hammer Forms

B. Zinc Alloy or Kirksite Hammer Forms

C. Plastic Faced Hammer Forms

1. Wood Core

2. Kirksite Core

3. Epoxy Resin and Filler Core

4. Phonolic Resin and Phonolic Foam Core

III. Die Sets

IV. Summary

THE USE OF PLASTIC TOOLS IN FORMING PROTOTYPE SHEET METAL PARTS

Richard S. Vanker
Foreman - Plastic Department
Wettlaufer Engineering Division
Pioneer Engineering and Manufacturing Company
Warren, Michigan

I. Introduction

Is it worth spending \$10,000 to insure an expenditure of \$600,000? As an added benefit you will gain peace of mind that a given part will perform the function it was designed to do. This insurance premium is spent to manufacture tools for prototype parts.

The purpose of this paper is to outline the method of making plastic or plastic faced tools for this use. I will cover such items as the need for prototype parts, how they are made, a comparison of cost to make in various ways, and a comparison of time to make in various ways.

Although the methods described could be used to make almost any type of prototype sheet metal part, I will refer to automotive panels.

The need for prototype sheet metal parts come into existence for all practical purposes with the advent of the metal automotive body. Why do we need these prototypes? Millions of dollars are expended annually in an effort to make automobiles more appealing and useful. This money is spent on design, product engineering, tool engineering, tool manufacturing, assembly facilities, and many other operations necessary before a finished product can be rolled off the end of an assembly line. It follows that before this money is spent there is an economic necessity to be assured that all of the parts designed and engineered to produce this new automobile will perform the function expected of them.

How do we obtain this assurance? The logical method of evaluating the feasibility and durability of the multitude of components used in the assembly of this new automobile is to make a working model or prototype. Now that this has been determined, the next answer to find is the most practical method of making the parts for this working model. Each item must represent the production counterpart very accurately. This will have to be accomplished without the aid of production tooling. We must now improvise an economical and speedy method to make the desired part.

There are two commonly used methods to make such parts: Hammer Forms, and Die Sets.

II. Hammer Forms

What is a hammer form? A hammer form is an object over which we are able to place a piece of sheet metal, fasten it down and with certain hand tools shape the metal to the form. This is done mainly with a hammer and a strong arm.

There are three common types of hammer forms:

A. Wood Hammer Forms

First we will take the hardwood hammer form. It can be used where the desired part has a smooth flowing contour and a very limited number of pieces are to be made. At times, metal inserts are added in areas of detail or sharp corners to help them withstand the pounding. This type of tool is made from a blueprint and worked with templates to obtain the surface. We use this type of tool when there is no model or pattern available to use in obtaining the required surface. (See Figure 1)

B. Zinc Alloy or Kirksite Hammer Forms

Next we have the kirksite hammer forms. They are used where a higher number of parts required or where the detail is such that the wood will not stand up. A standard size die model or expanded wood pattern is required to make this tool. If we use a die model we have to make an expansion plaster. The expansion is to allow for metal shrinkage.

Perhaps I should explain expansion plaster. It is plaster that when mixed with water and poured in a mould will grow while curing. This growth can be controlled to a certain extent. From this expansion plaster, which grows the required amount, we take a hard plaster pattern. Then either the expanded wood pattern or plaster pattern is rammed up in sand. (See Figure 2) The metal is poured into the open sand mould after the pattern is removed. (See Figure 3) When removed from the sand the casting will be very close to size. The surfacing or barbering required is negligible. This sounds ideal doesn't it? Well it is, except for one thing. You get an awful empty feeling when a large casting such as a roof, hood, or deck lid is set up for inspection and you find that in the process of cooling it has sagged or has not shrunk properly. Therefore I would not recommend a kirksite hammer form on a large part.

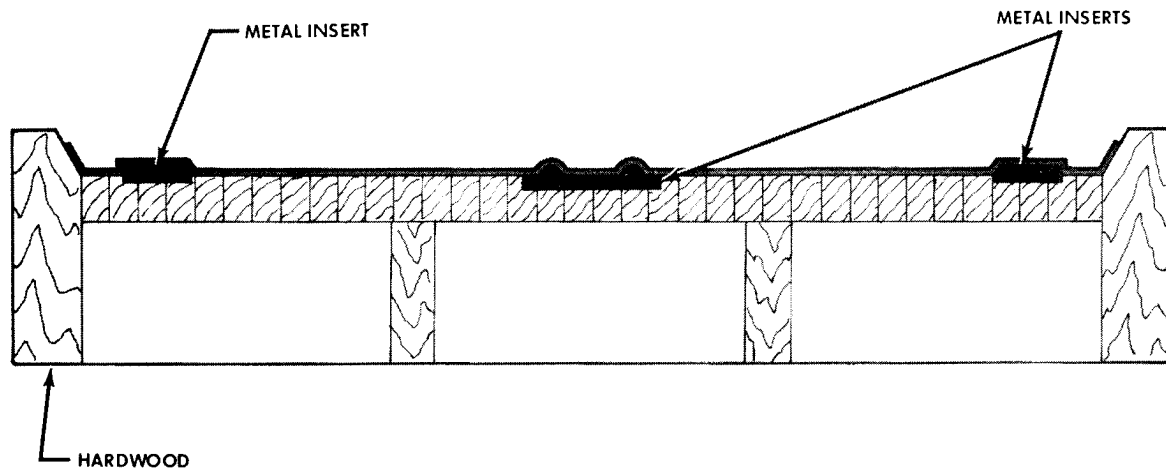

FIG.1 HARDWOOD HAMMER FORM

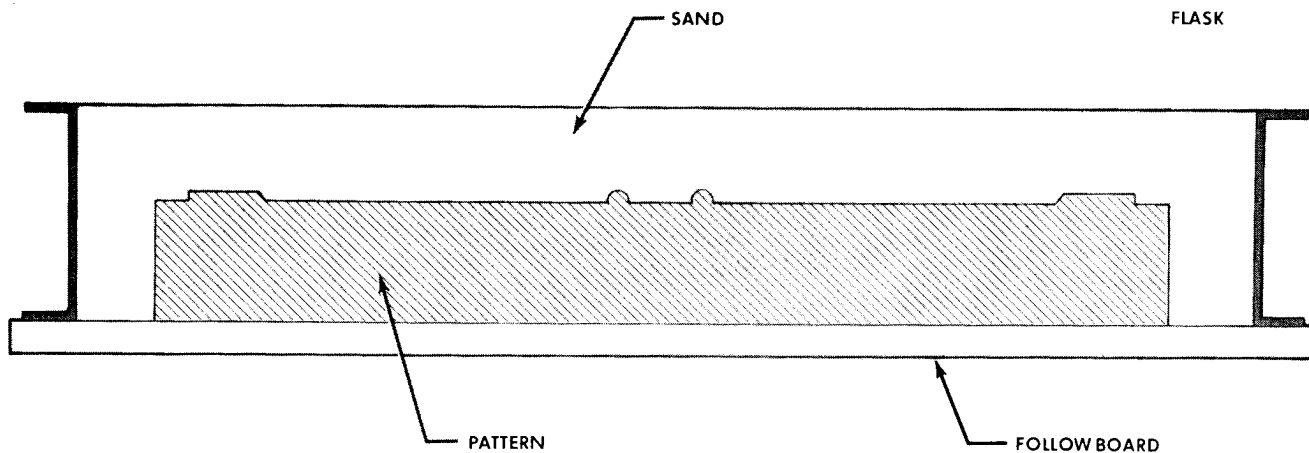

FIG.2 EXPANDED WOOD OR PLASTER PATTERN IN SAND

C. Plastic Faced Hammer Forms

We now come to the last type, the plastic hammer form. It has been determined that the typical application for a plastic hammer form is when the part is large and kirksite will not hold dimensionally, when there is more detail or a greater number of pieces than wood will make, or when there are no facilities to pour kirksite.

Plastic hammer forms can be made in many ways. Such as plastic face with a wood core, plastic face with a slurry of plastic and stone, aluminum shot, or many other fillers mixed with it. The fillers will help prevent or dissipate the exotherm heat that all thermo-setting resins produce. Also we have a plastic faced with a kirksite core, or a plastic face with a phonolic core. These are the commonly used types. The different kinds of plastic hammer forms are too numerous to go into here so we will concentrate on the ones mentioned.

A proper aid is required to make any plastic hammer form. The desired aid would be a standard size die model, plaster, or plastic made the opposite of the hammer for. The reason I say standard is that we have no shrinkage to contend with in plastic as we do in metal. At times we end up a metal thickness away from the hammer form in our aid, in this instance we wax the metal thickness in with sheet wax made of this purpose.

Now that we have the proper aid which can be used to make any type of plastic hammer form we must make a decision on which type we will make. This decision is based on many factors such as contour and detail of part, size of part, number of pieces required, available equipment, etc.

I might mention at this time when I speak of plastic face I am referring to epoxy aluminum filled resin.

1. Wood Core

First let us take plastic face with wood core (See Figure 4) A hardwood core is fit to the surface of the available aid. There is a gap of approximately 1/4 inch allowed to pour plastic face. When the core is fit it is suspended in the cavity, sealed off leaving sprues and air vents, now the plastic is poured. When cured the aid and hammer form are separated. The surface should be checked for air voids and patched if found. These voids, and you are almost sure to find some, should be

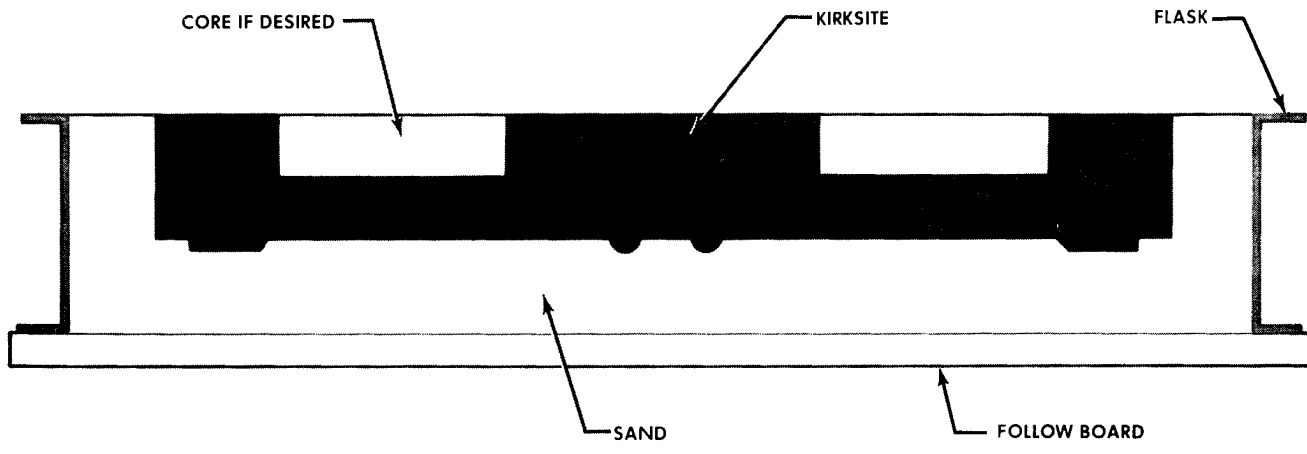

FIG. 3 POUR KIRKSITE IN OPEN SAND MOLD

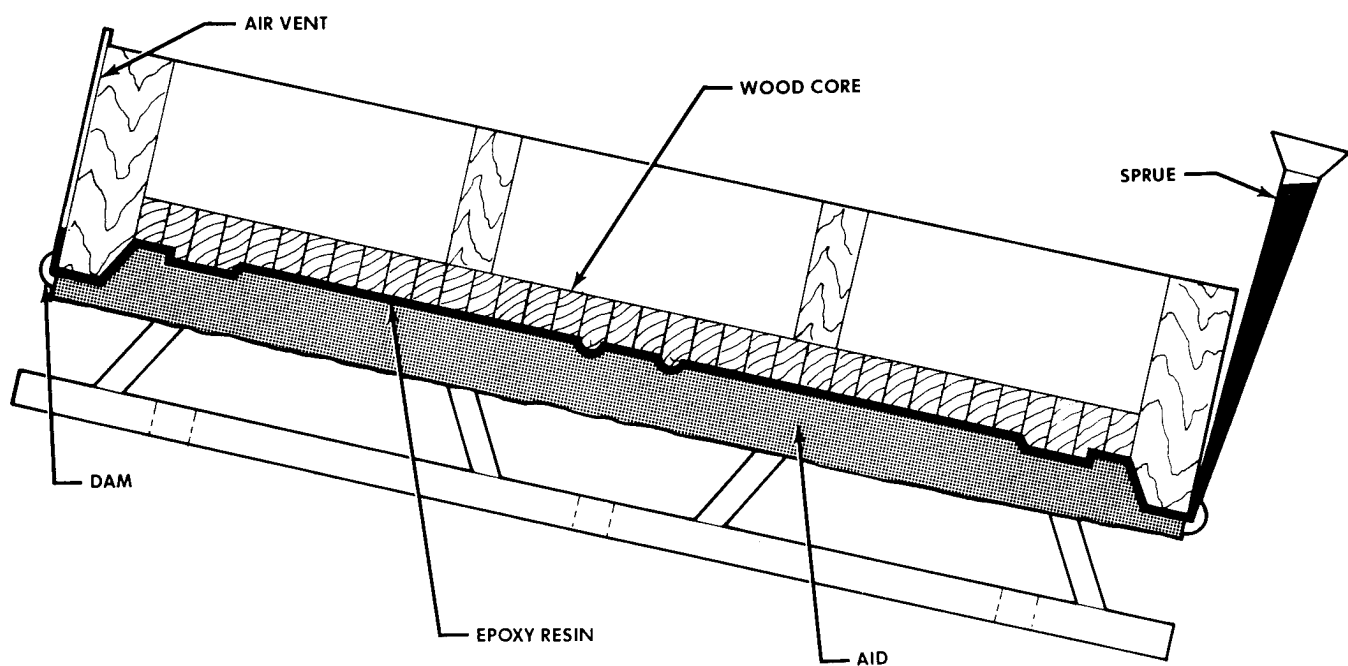

FIG. 4 PLASTIC FACE WITH WOOD CORE

patched and worked off now. If not fixed, the metal will pick up the impressions while being formed. When this is done you are ready to form the part.

2. Kirksite Core

A plastic faced hammer form with a kirksite core is made basically the same way. (See Figure 5) The exception is instead of fitting wood to the aid surface a plaster pattern is taken from it. This pattern is rammed in the sand standard size. We want the casting to shrink so it will allow a gap to pour the plastic into. The core should be blasted or roughed up and any oily film removed to assure a good bond between plastic and kirksite.

3. Epoxy Resin and Filler Core

Next we have plastic face with epoxy resin and filler core. (See Figure 6) We first paint a gel coat of resin on the surface of the aid, when it becomes tacky I recommend laminating a few layers of fiberglass cloth on it. We then mix a mass casting epoxy resin with the filler and pour it in the cavity. When hard or cured follow the same procedure as on other hammer forms.

4. Phonolic Resin and Phonolic Foam Core

Lastly we come to the type of hammer form that I would recommend for general use. An epoxy aluminum filled resin face with a phonolic foam core that is encased in approximately 1 to 1 1/2 inches of phonolic resin. (See Figure 7) This type is made by using a standard size aid, again no shrink is required. This aid should have a box built around it and anchored securely. Into this box a core of phonolic foam is fit very roughly. The foam can be worked easily with a saw or even a jackknife. This foam should be fit from 1-1/4" to 1-3/4" away from finished surface.

This finished surface of aid must now be caulked approximately 1/4" to allow for final surface pour. The caulking can be accomplished by using plywood, clay, wax, or any other type of material that is suitable. Now we suspend the foam core in the cavity and pour the gap between the core and aid full with phonolic resin. Allow 24 hour cure and remove phonolic covered foam from the aid. We then remove caulking, clean the surface of the aid, rough up core, suspend core back in cavity and make final pour with aluminum filled epoxy. When cured and removed from aid follow the same procedure as on other types.

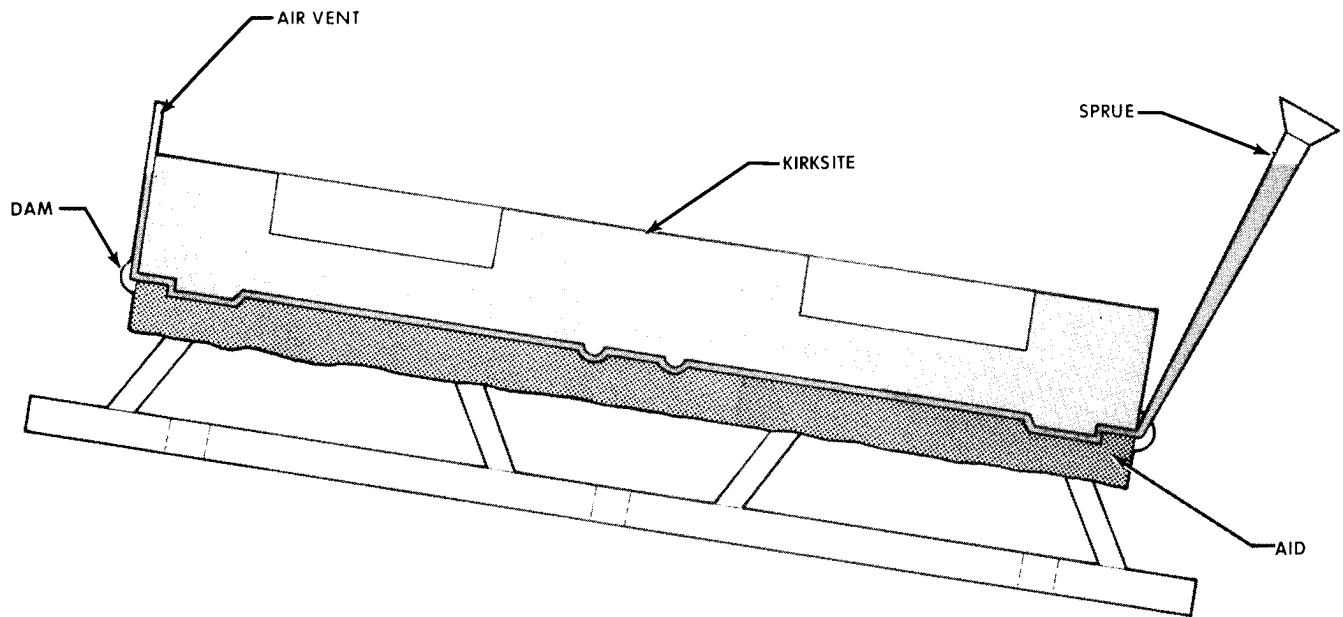

FIG. 5 PLASTIC FACE WITH KIRKSITE CORE

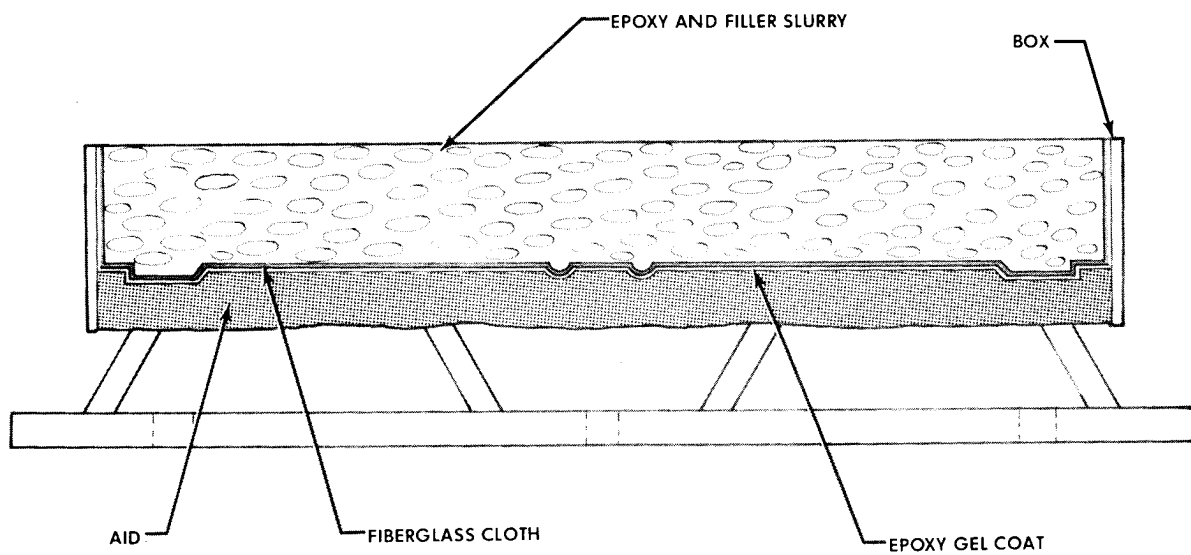

FIG. 6 EPOXY FACE WITH EPOXY RESIN AND FILLER SLURRY

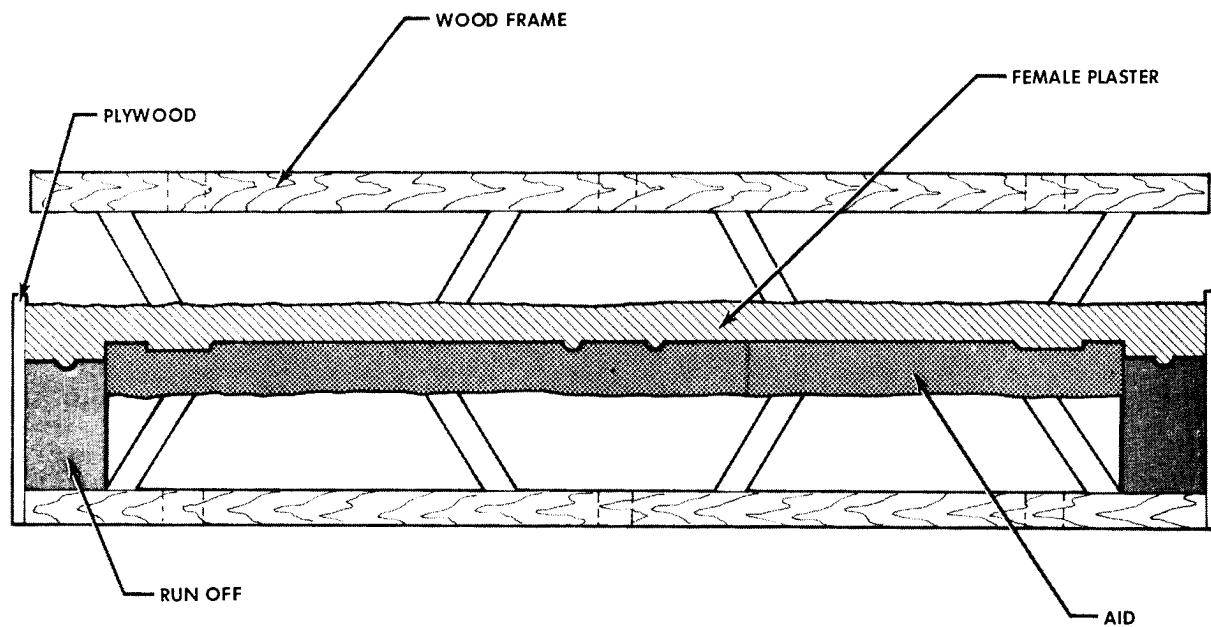

FIG. 8 ADD RUN OFF, RING SURFACE AND MAKE FEMALE PLASTER

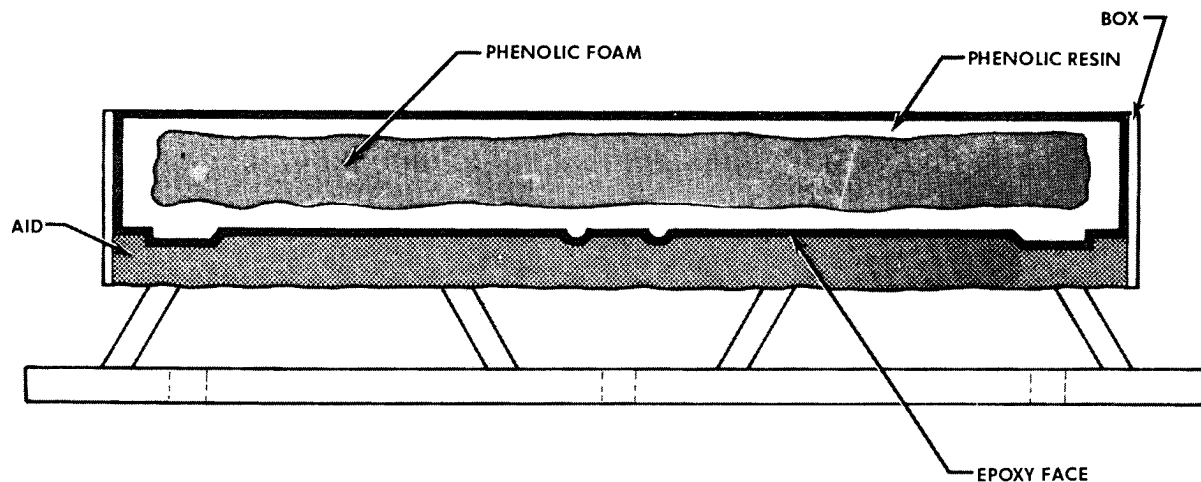

FIG.7 EPOXY FACE WITH PHENOLIC FOAM AND PHENOLIC RESIN CORE

I favor this last type of hammer form for three reasons, cost, time required to make, and weight. The cost is less than using a kirksite core because the labor required to make patterns and pour castings is higher than to fit foam and pour phonolic. The same thing holds true on wood cores. The time element is also less. A phonolic core hammer form can be made in five days compared to the same tool with kirksite core in seven days. This is because the phonolic core is being made during the time we are making a standard pattern, we then are pouring a plastic face when we would be pouring the kirksite core. Also plastic is lighter than kirksite making it easier to move around and work with. If it becomes necessary to make an engineering change in the form it is much easier to cut away plastic than kirksite.

As you see, it can be a difficult choice to decide which type to use. The type of equipment you have and experience are the two main factors in helping you make this decision.

III. Die Sets

We will now delve into the high priced method of making prototype sheet metal parts. Namely, die sets. The cost to make a die set is considerably higher than the cost of a hammer form. The reasons to justify spending the extra money for the tools are as follows. The part will more closely represent the production stamping if made by a die set than if hammer formed. It is much easier to maintain proper metal thickness. Also the quantity has to be taken into consideration. The higher the number of pieces required, the cheaper a die set becomes because they can be stamped faster than hammer formed. Therefore, before deciding which direction to take, a part must be analyzed thoroughly to decide the most economical method to use for the desired results.

The same rule on size holds true as for a hammer form. The smaller jobs are suitable to be made of all kirksite. The die set normally consists of three pieces on larger panels. The three pieces are the die, punch, and ring. We find that to start making these tools the desired aid to have is an inside of metal female cast off of the standard size model. From this female a hard male plaster is made. After adding runoff and required die surface on this plaster, a new female plaster is taken. (See Figure 8) We then develop a plaster in this female to use for a punch pattern. Also another plaster is developed around this punch to use for ring pattern. We now have three patterns, a female for the die, the male for the punch, and the ring. A small amount of revising

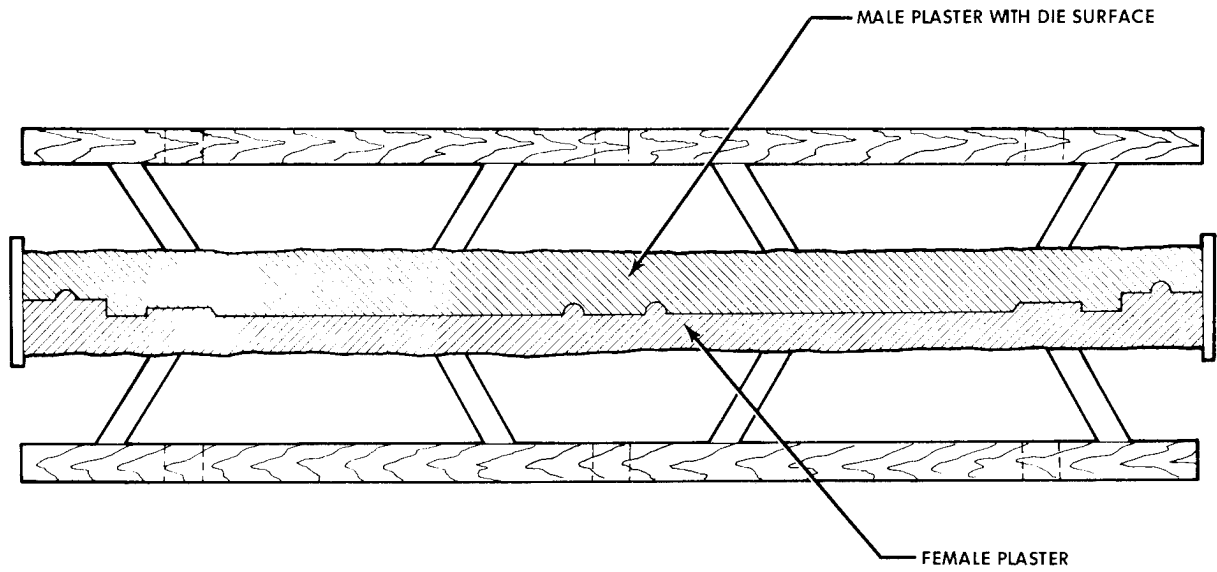

FIG. 9 MAKE MALE PLASTER TO USE FOR DIE

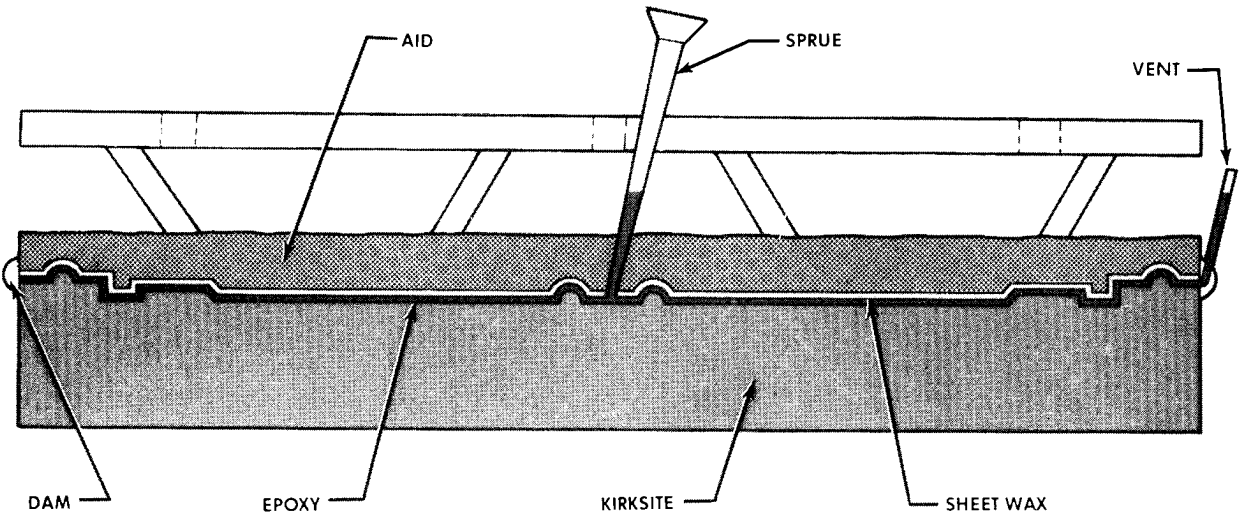

FIG. 10 POUR EPOXY FACE ON DIE

was necessary to allow for shrink on detail only. We want these castings to come out smaller, this will allow a gap for pouring plastic face. Using these patterns the cores are made.

Now we take the original female plaster with the die buildup on and make a male plaster with the desired die surface. (See Figure 9) We then add sheet wax to the surface of the male plaster to allow for metal thickness, and after cleaning and roughing the surface of the kirksite core, match them together. Leave approximately 1/4 inch gap between them, seal off the joint leaving sprues and air vents, and pour resin. (See Figure 10) Let cure over night and take apart. The sheet wax is to remain with the die if possible. Suspend the punch core and repeat the whole operation. (See Figure 11) When cured, take apart, clean flash off of the punch and place it back in die. Locate the ring core around the punch in manner that it can be relocated, then remove the ring core and punch. (See Figure 12) Now put ring bore back on die after adding plastic between them to be squashed.

At this time the bottom of all three castings should be either machined or squashed flat and parallel with plastic.

Clean the surface of all three and check for air voids. Next we place in press and proceed the same as we would with any prototype die. (See Figure 13)

In many cases these die sets will not make a complete part due to conditions that will not allow a one hit operation. We then use partial hammer forms to complete the flanging, etc.

Timing is always important in prototype tooling and so is the cost factor. For comparison purposes let us take a complete hood assembly.

If you have the manpower and facilities to work all components simultaneously, hammer forms could be made in approximately two to three weeks and parts could be assembled and delivered in five weeks from when job was started.

Using die set method tools could be made in four to five weeks and assemblies delivered in approximately eight weeks.

Cost of these methods are difficult to compare because of the various ways that they can be made. But in general a complete set of hammer forms will cost around 20% to 30% of what a complete set of dies will.

As I said before, this difference in cost may be justified by the number of pieces involved or the quality of the part required. In

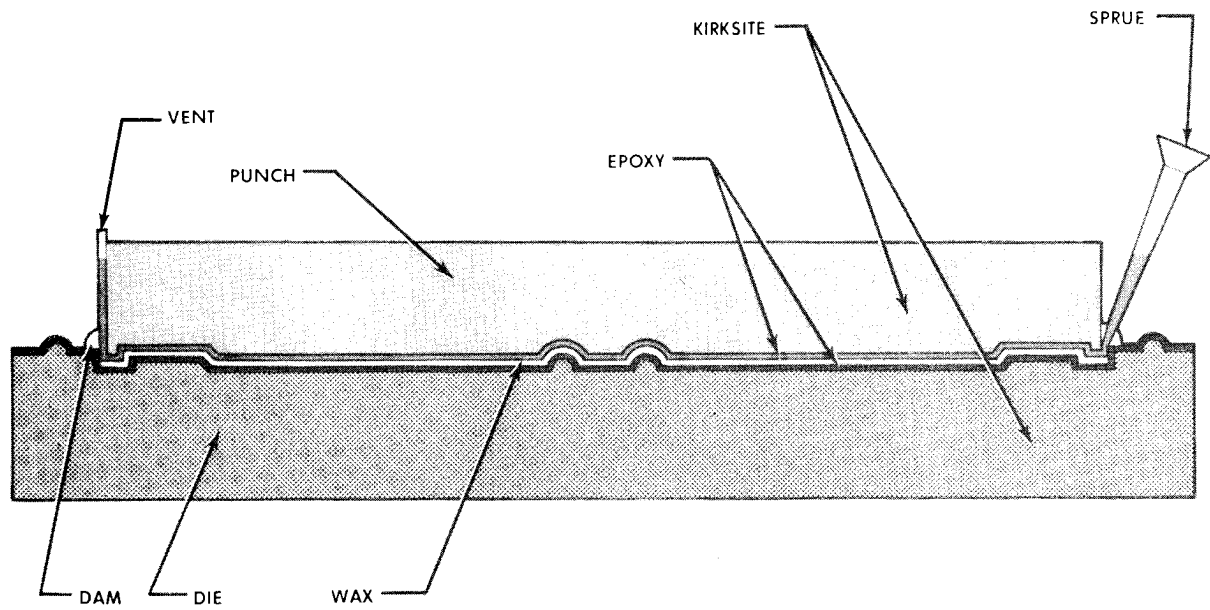

FIG.11 POUR EPOXY FACE ON PUNCH

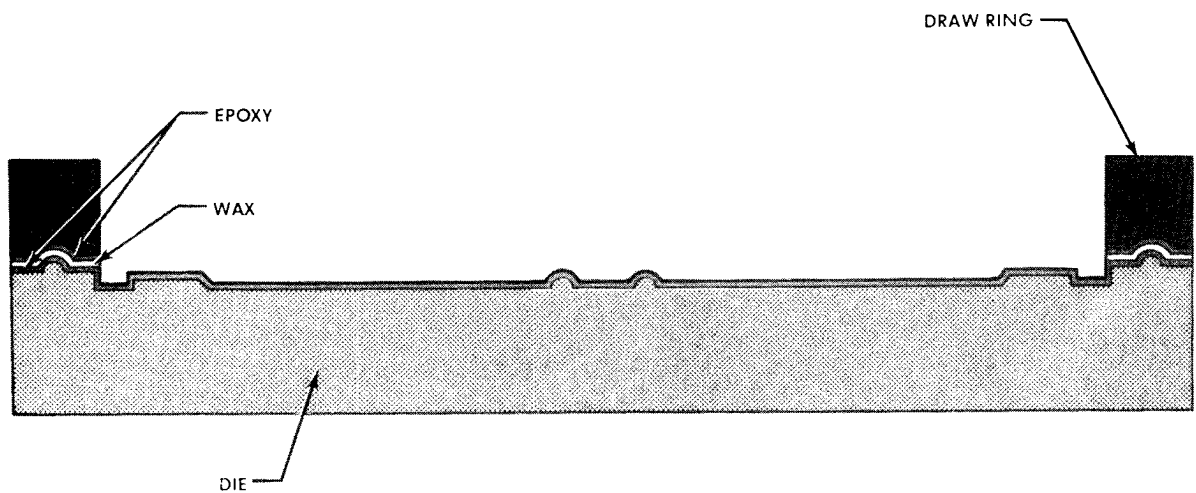

FIG.12 SQUASH EPOXY FACE ON RING

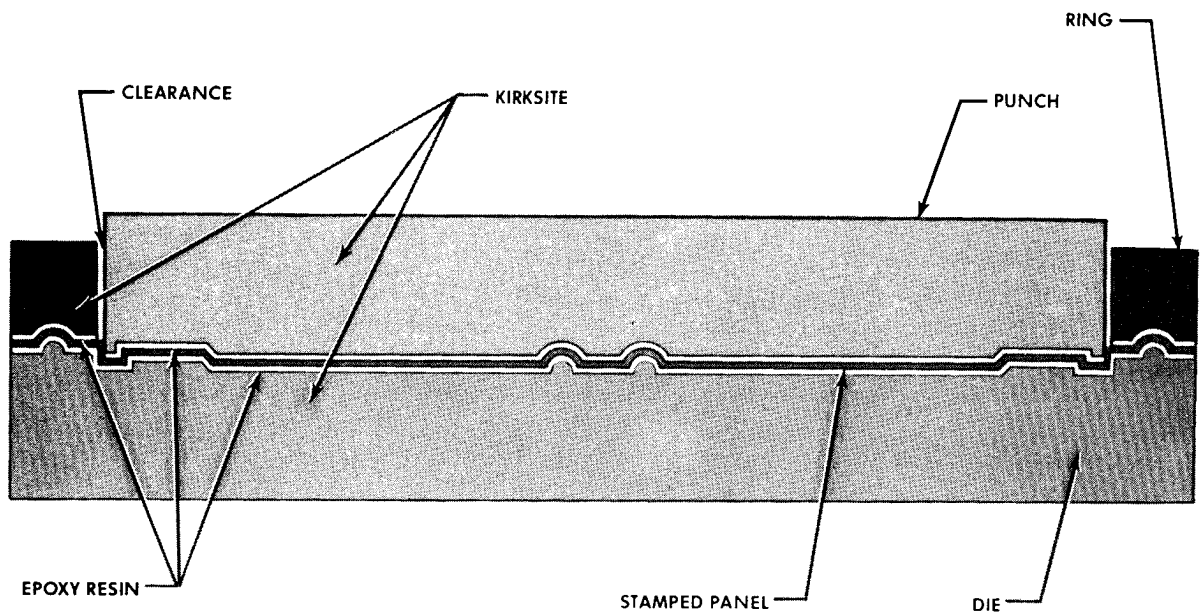

FIG.13 THREE PIECE PLASTIC FACED KIRKSITE DIE SET

either case the cost of the prototype tooling is very small compared to production tooling.

IV. Summary

In conclusion I would like to say that in my opinion, a wide awake concern that intends to remain in the prototype metal part business should be versatile enough to be able to make a tool that is suitable to make any required part. Although I have briefly described many ways to make a tool for prototype parts, I have not stated that any one way is best. Each part must be analyzed as an individual before deciding what kind of tool to spend the money on. The money I speak of could be classified as the insurance premium mentioned in the beginning.

Section N

Production Tooling for Drawing Operations

B. L. Harrison

PRODUCTION TOOLING FOR DRAWING OPERATIONS

B. L. Harrison
General Foreman, Production Sheet Metal
Hamilton Standard, A Division of United Aircraft
Windsor Locks, Connecticut

Introduction:

Persons that are associated with the forming of sheet metal parts and the assembly of these details into finished products are familiar with the many types of machinery and the assortment of tools required to accomplish the fabrication of the products being manufactured. As these forming requirements can vary from detail to detail; therefore, they can also vary from plant to plant, so this presentation will only cover the application of epoxy tooling resins to single male tooling forms adapted for use on two Cincinnati Hydroforming Presses of 26" and 12" diameters with a maximum available forming pressure of 15,000 PSI.

The hydroforming process is similar to the Marform and the Hydraw forming process as these two processes employ a deep rubber pad in the ram of the press with a stationary punch on the bed of the press. A blank holder plate actuated by a special control die cushion, controls the pressure of the blank as it draws around the punch. The hydroforming press is similar in action, except the rubber pad is replaced by hydraulic fluid contained in a cavity in the ram, which exerts pressure upon a rubber diaphragm. The punch moves upward, causing the metal to flow around the punch and forms the part.

Epoxy tooling plastics, as formulated today, are versatile compounds, which have the capabilities of functioning as a replacement for steel, Kirksite or other metallic materials used as a die material for forming sheet metal details. The epoxy tooling resins systems can be applied as a die material using several methods; such as:

1. The mass casting technique with added fillers of sand, marbles, or stone.
2. A metal build-up or rough casting of various metals, or;
3. An epoxy surface coat with a glass fabric and epoxy resin lamination, which can be used in combination with item #1 and #2 or;
4. It may be a straight mass casting resin without benefit of any fillers other than that formulated into the resin system by the formulator.

Usage of the above methods or any combination of the same is dependent upon the tooling manufacturing engineers or the tool designers concept as to what the forming requirements will be, to what type of equipment is to be utilized in forming, the tool life expectancy in relation to quantity of part to be manufactured, lead time for tool fabrication, materials to be formed on the plastic tools and the configuration of the part to be formed. These are conditions that must be considered before a firm or final method to tool fabrication can be established.

To establish the basic tooling pattern configuration, several methods of tool fabrication can be employed with equal end results. The most common methods used are the plaster and the wood patterns; but hand formed sheet metal details used in a component mock-up can also be used as a basis for the tooling pattern. The plaster and the wood patterns can be made to represent the net part or the actual forming pattern, which includes excess depth to compensate for the metal drawing requirements. The sheet metal part, being to net trim, will require the addition of excess depth for forming as would the plaster or wood pattern representing the same condition. From the above male patterns a plaster cast is permitted to cure on the pattern for several hours before removing to insure that no warpage of the cast will occur. The pattern is then oven dried at a temperature not to exceed 125° F., sealed, and processed for the pouring of the plastic compounds.

After the plastic casting operation is completed, the plastic is permitted to cure at ambient temperature for a minimum of 12 hours before removal from the plaster pattern; but when ever practical the cure cycle is extended, in the pattern, to 72 hours or more to insure a more complete cure of the plastic casting. If it is necessary, due to production demands to expedite the tool, it may be cured in a 100° F. oven for several hours; but this expedited cure should not begin prior to the initial set of the plastic material. If a temperature above 100° F. is used the plaster pattern may weep moisture into the plastic casting creating voids in the casting or the possibility of losing the casting in its entirety.

Entrance into this Plastic Tooling Program was generated by the lack of tooling lead time, to room availability for hard tool fabrication, and the experimental design of the product. The product, being of prototype design, was modified several times before the design and tooling stability for production was established. (Fig. #1)

This header forming tool represents one of three plastic tools in a heat exchanger package. The three header tools to be represented here are approximately equal in size and required from 800 to 1000 cubic inches of casting resin per tool. Plaster and wood tooling pat-

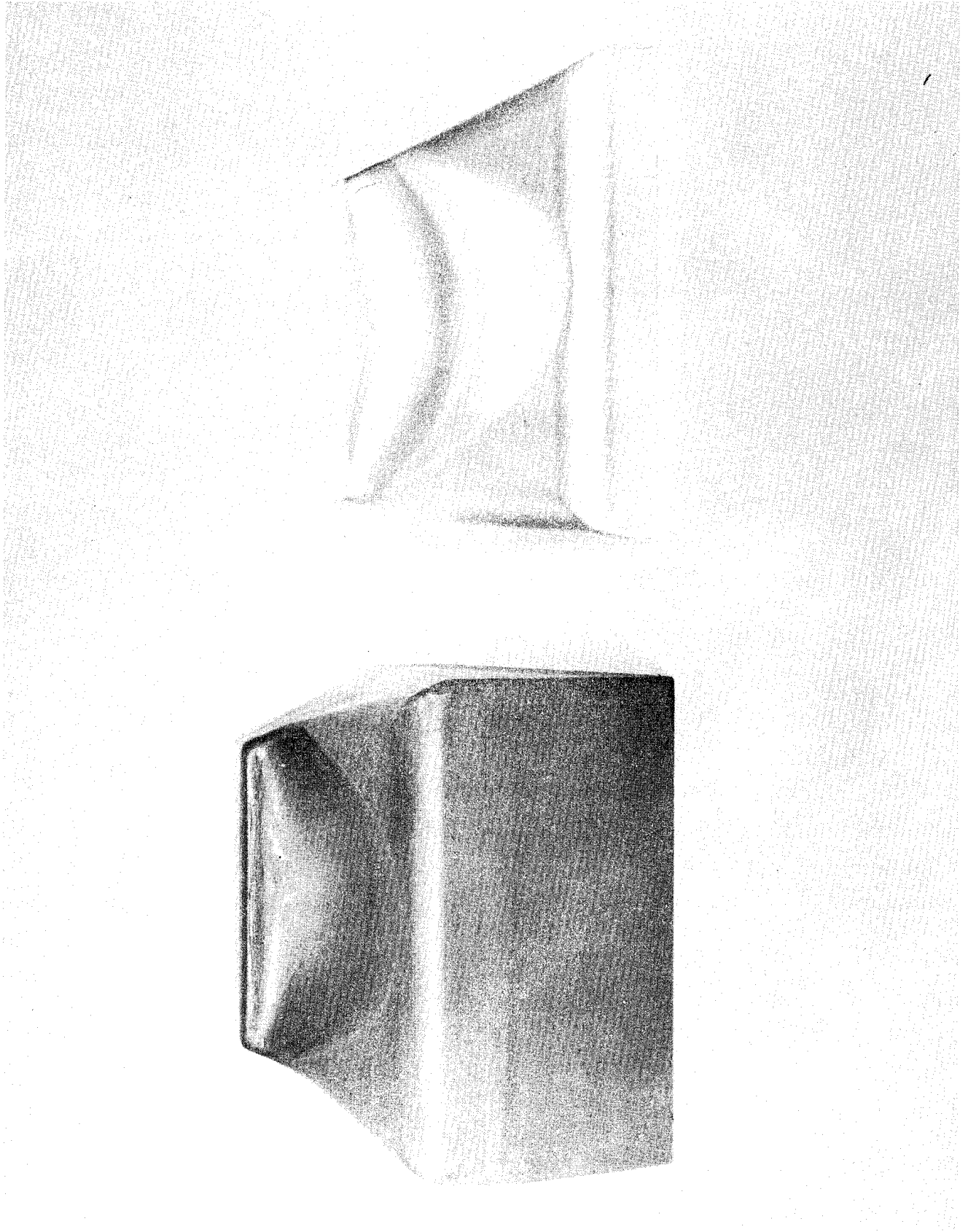

terns were used to establish the basic tool configuration for the three header forming tools.

Forming of the sheet metal headers is accomplished on the 26 inch Cincinnati Hydroforming Press. The material gages of the three header parts varying from .067 to .054 inch AMS 4015 (5052-0) aluminum. The final displacement forming pressure of the three parts, likewise vary from 1500 PSI to 4000 PSI. Blank material sizes range from 165 to 298 square inches and this variation in size is due to the forming condition of each part.

Evidence of die wear or deterioration of the tool, due to press forming is not apparent on any external surface of the tool, although sharp corner radii have been damaged through shop handling and a bench hand forming operation. As this damage is of minor concern, no repair has been made in this local area as yet. If a firm configuration had been established during the tool casting operation metal inserts could have been incorporated into the casting at that time. (Fig. #2)

The final trimmed production part in relation to the forming tool shows the part as being split at these two sharp corners, this condition is a production requirement, due to a form to fit operation into the next assembly; therefore, the damaged corners are of no concern to us at this time and repairs of this area will be made when it becomes necessary. (Fig. #3)

This tool from the same mock-up, has the least severe forming condition of the three tools, but has the greatest forming depth due to the position of the elliptical end in relation to the aft trim line of the part. (Fig. #4)

The contour of this part, which has the only flat center line surface that exists in this family of tools made it possible to balance the tool to the ideal forming position and due to this forming condition, the tool has the least evidence of any surface forming wear or fatigue. The shiny surface on the elliptical end of the tool is due to grinding away a sharp edge not to tool wear. (Fig. #5)

The last plastic forming tool in this heat exchanger mock-up is a saddle back die and represents the most difficult sheet metal forming condition of the tool family. As only one forming operation was required on the preceding tools a maximum displacement forming pressure of 1500 PSI, a maximum displacement forming pressure of 4000 PSI is required to form this metal detail. To complete the forming of this part three operations are used, of which two are in the press, the other being a hand forming between the press forming operations and in the area of the two plateaus located on the elliptical end. (Fig. #6)

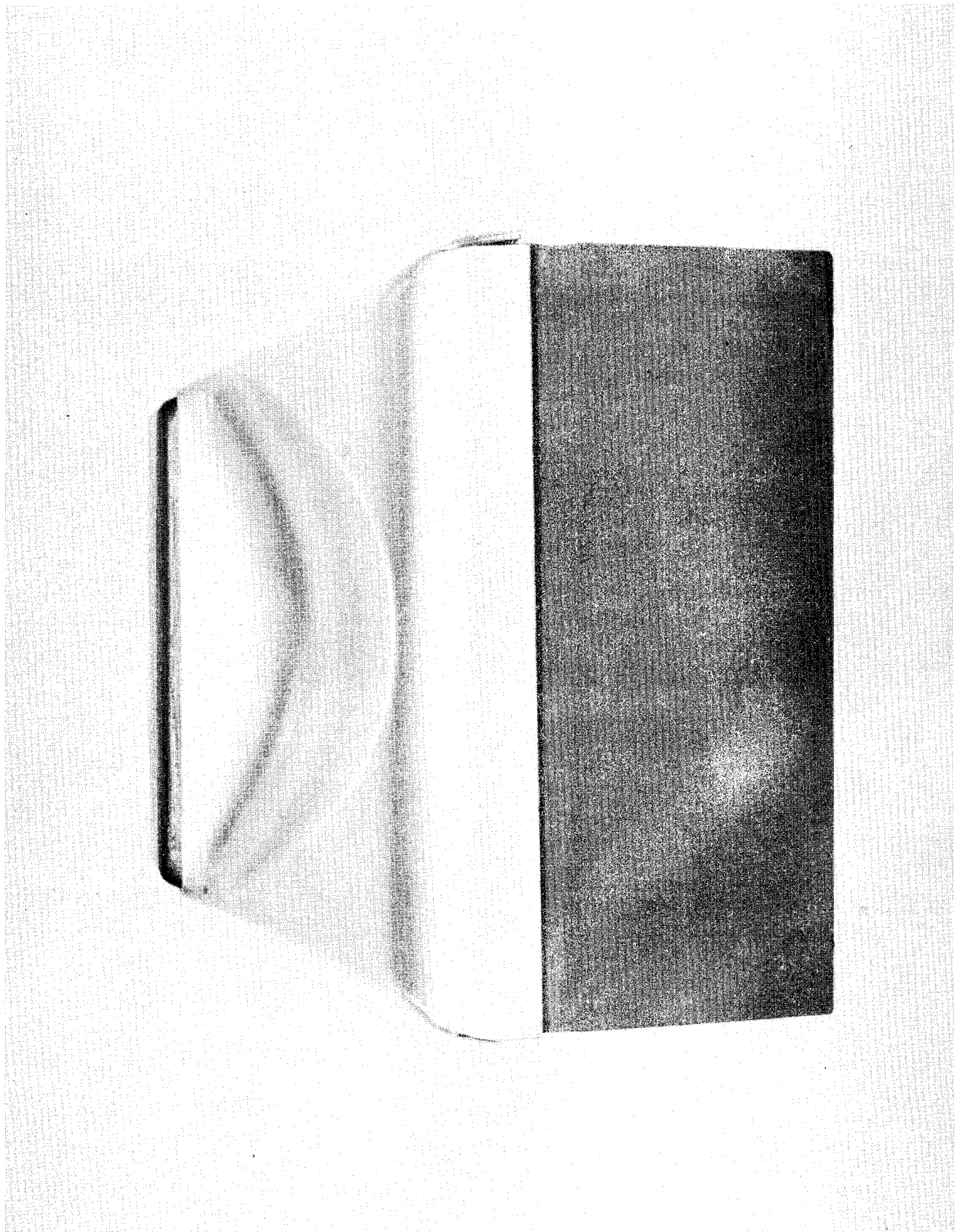

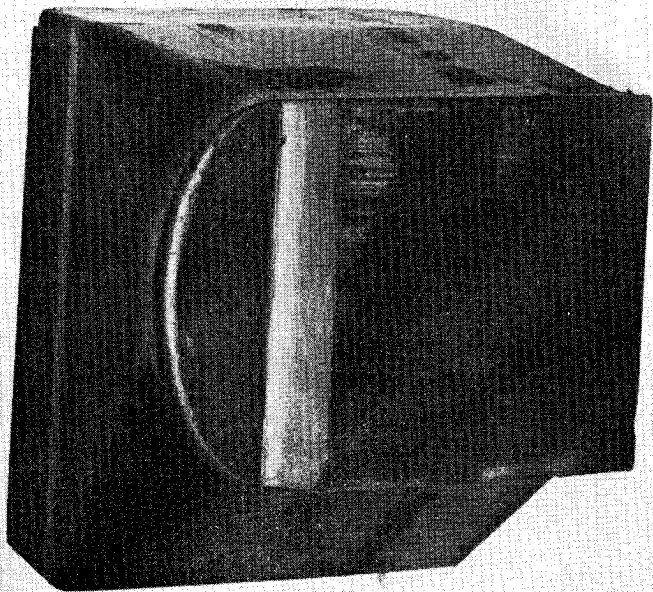
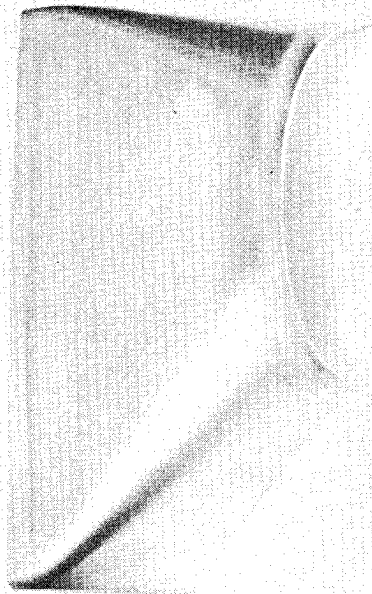

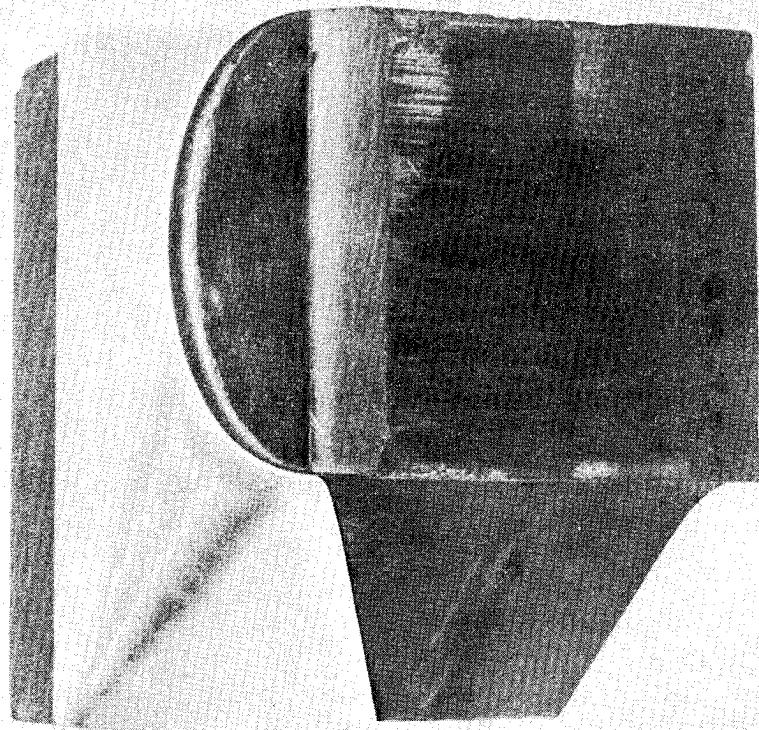

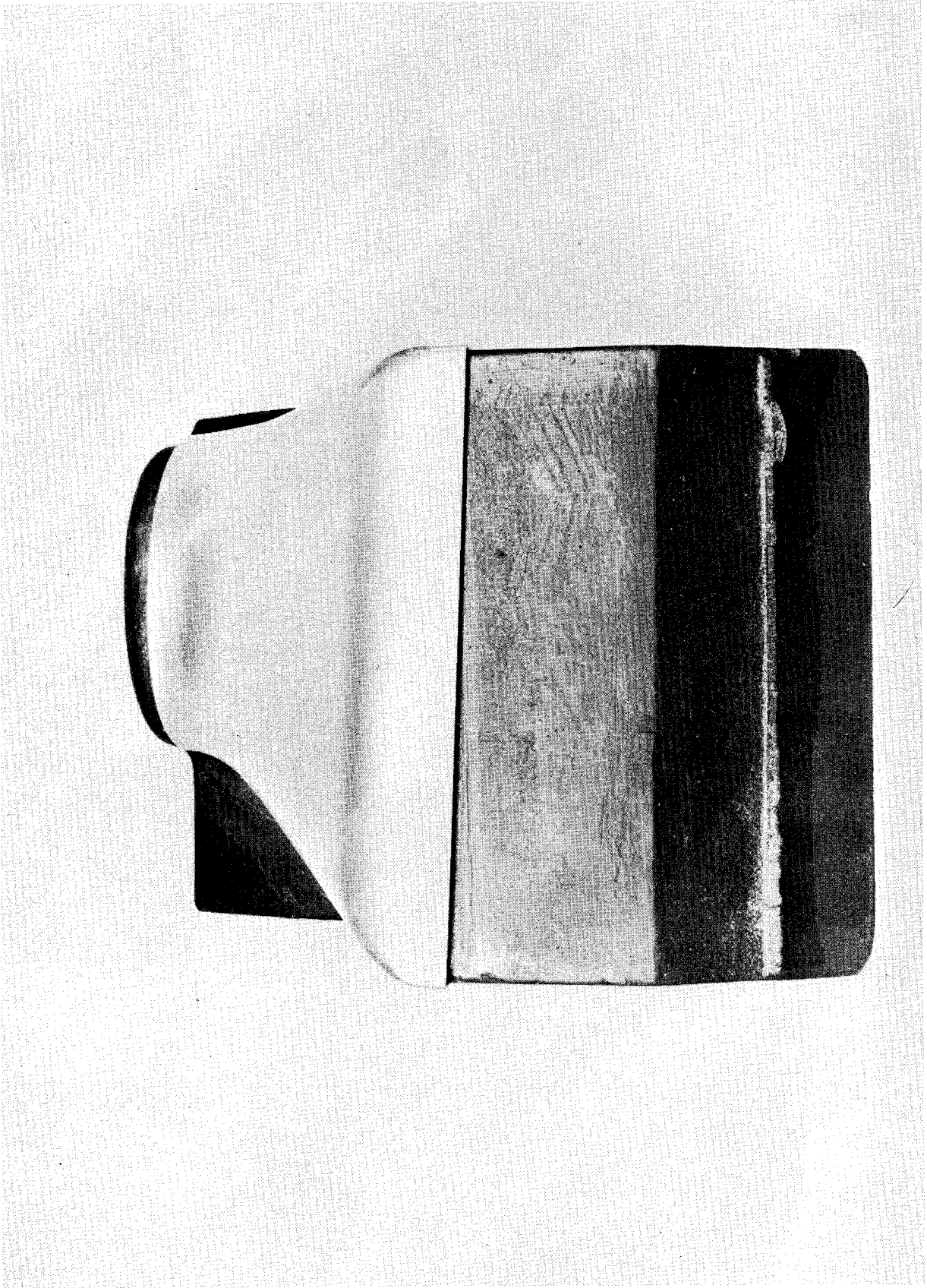

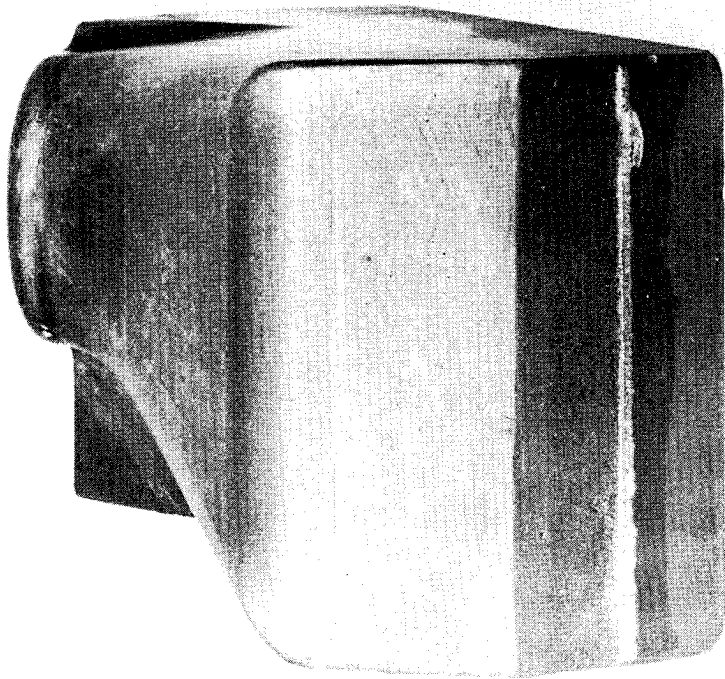
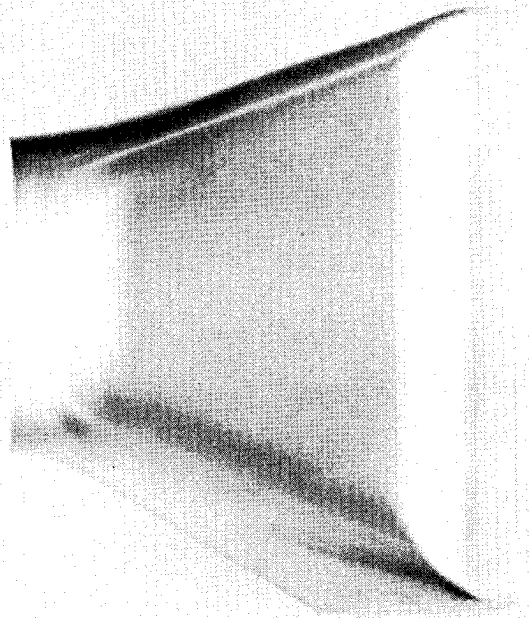

This tool has formed as many parts as the rest of the family of tools; but, with twice the exposure to forming pressures as the other tools plus the sharp impact of hand forming, yet the appearance of the tool does not indicate any evidence of any excess wear of forming fatigue. From all appearance the present tool condition of the tool family indicates that the tool life will exceed the intended production requirements.

The mass of plastic to be casted in each pattern of this tooling program was of a major concern due to the possibility that excessive exothermic heat might be generated during the casting operation and warp the tool, but in no case was this condition in evidence as all parts formed on these tools meet the blueprint requirements. (Fig. #7)

This duct half, which is an accessory part in the same heat exchanger package, has been adapted to the 12 inch forming press and is made from .035 inch AMS 4015 aluminum. The part has a 90° angle bend and a .75 radius to be formed. Due to this radius, it is necessary after the completion of the first forming operation to trim the excess material from the part, reposition the part on the tool and partially hand form this radius prior to the second forming operation. The forming pressures used on this tool are the greatest of all forming pressures used on any tool illustrated in this tooling program. (Fig. #8)

The initial pressure required to form this sheet metal detail is 1500 PSI with a final displacement forming pressure of 9300 PSI being used to complete the forming requirement of the part.

It may be interesting to note, at this time, that all the finished trimmed sheet metal detail parts are approximately equal to one-half the depth of the plastic forming tools. (Fig. #9)

This .043 inch aluminum part represents one more sheet metal detail of the same aluminum heat exchanger program; but with a much more interesting history than the other tools of this plastic tooling package, as it has been made of cast Kirksite, steel, a resin and glass fabric lamination in combination with a resin and sand casting used for back-up; but due to drastic design changes all these tools have been scrapped and replaced by this mass cast epoxy resin forming tool. (Fig. #10)

Both left and right hand halves of this sheet metal detail have been adapted for forming on the 26 inch hydroforming press and require 3000 PSI pressure to complete the forming operation. The tool being at an on-balanced forming angle there is some evidence of wear in the same area on both the forming tools, but this wear, as shown, is below the trim line of the parts. This damage to the tools could have been



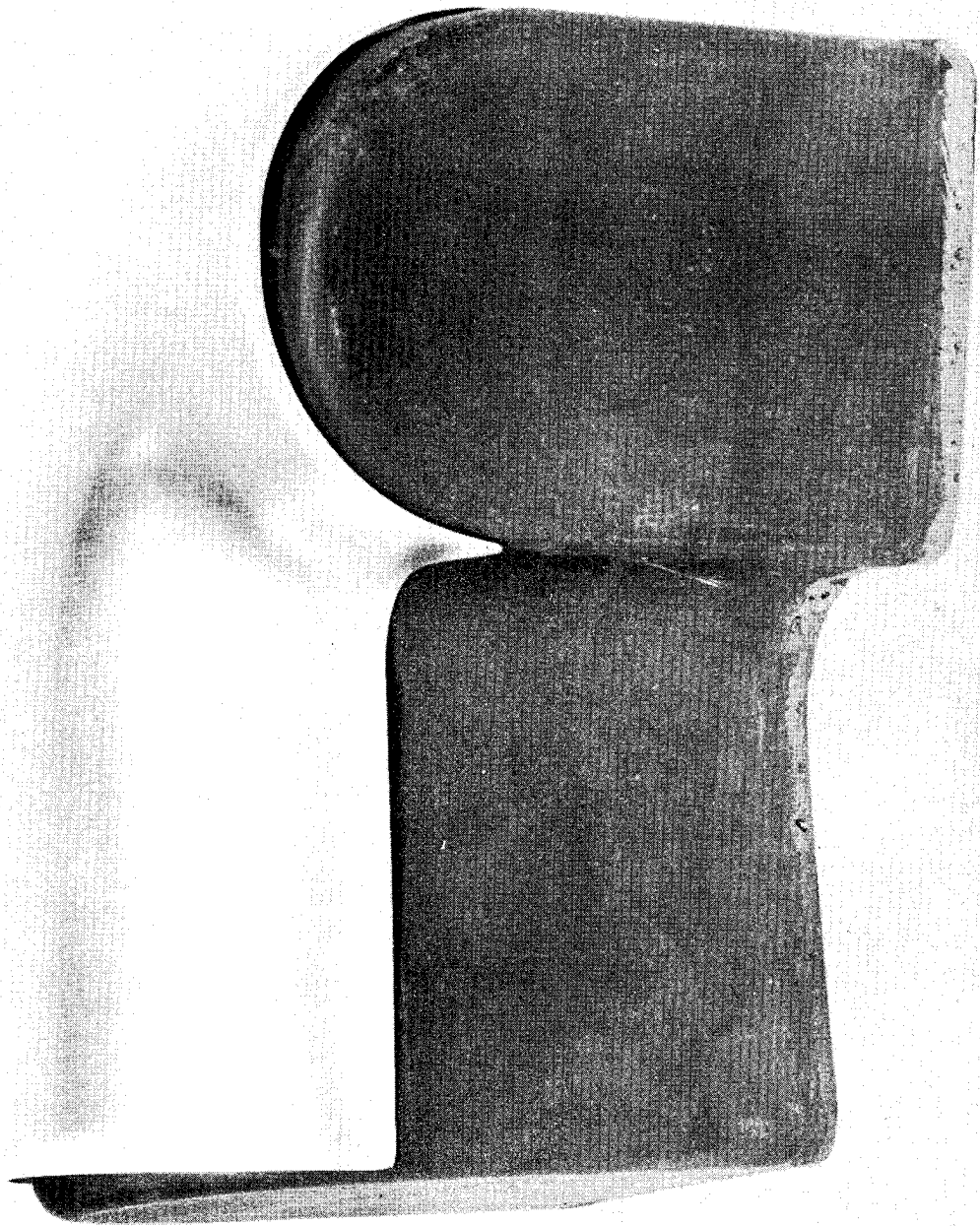

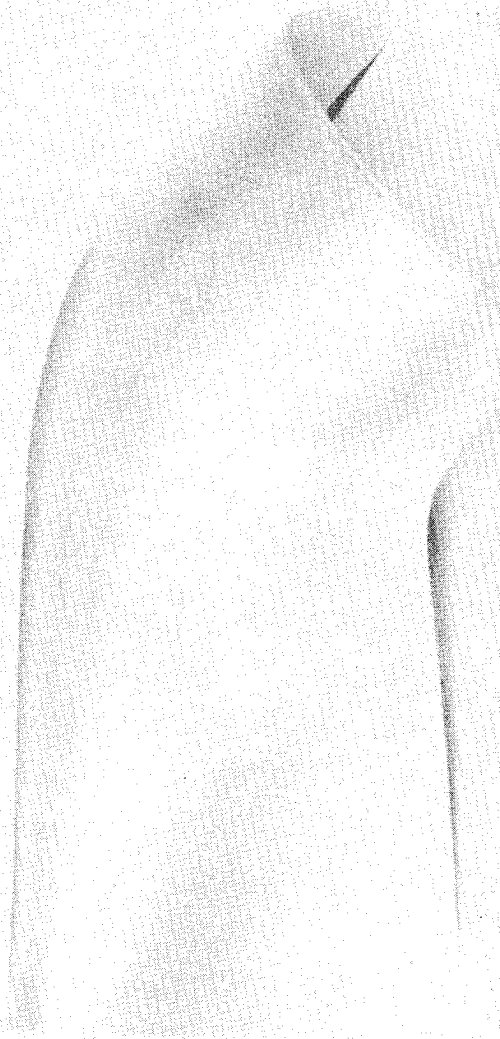



created during the period of tool prove out, but as several minor corrections to the tool have been made since this prove out no additional damage is apparent. (Fig. #11)

The forming of these two .028 stainless steel details is accomplished by using four forming operations, utilizing both the 26'' and the 12'' presses. Two forming operations are accomplished on cast Kirksite dies, the other two on plastic tools. The Kirksite forming tools are used to form the individual details which are rough trimmed after forming then placed on this plastic tool for additional individual forming and marking of the mating surfaces. A hardened steel insert has been incorporated into the plastic tool to accomplish this marking operation. The individual parts are again trimmed to the imprint line left in the part by the prior operation then heli-arc welded together. (Fig. #12)

After the welding operation has been completed the welded assembly is again formed to its final shape. This last forming operation is done on another cast plastic tool, which flattens out the raised imprint along the welded area. This may seem to be the long way around to accomplish the task, but the results have more than justified the effort of making two additional plastic forming tools. The parts now meet the blueprint and assembly requirements plus the assembly problems created by springback of the individual details has been eliminated. (Fig. #13)

The 12 inch press was utilized to form this .050 inch AMS 4025 (615-0) aluminum detail. A final forming pressure of 8500 PSI was required to form this detail to a 2.50 inch depth. It was a mass cast tool using the same casting procedure as used throughout this tooling program with the exception that an aluminum plate was attached to the base of the tool to reduce the possibility of tool breakdown in this area. (Fig. #14)

The forming of this sheet metal detail to this tool configuration was an experimental effort with several changes being made before this design was established.

Using plastic as the tooling material for this part, it was possible to make each change and cast a new forming tool for evaluation within a three to four day period. As this experimental tool has not been subjected to a production cycle, no estimated tool life can be established; but the configuration of the part and the high forming pressure required indicates that the tool life would be short with the possibility of maybe 100 parts, before breakdown of the plastic would occur.

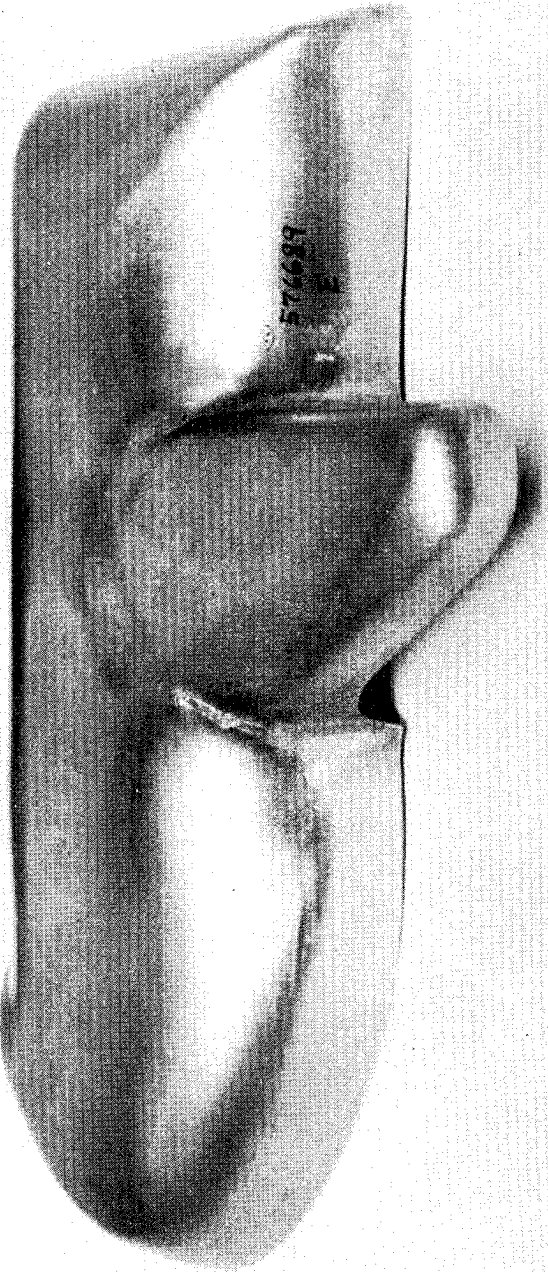
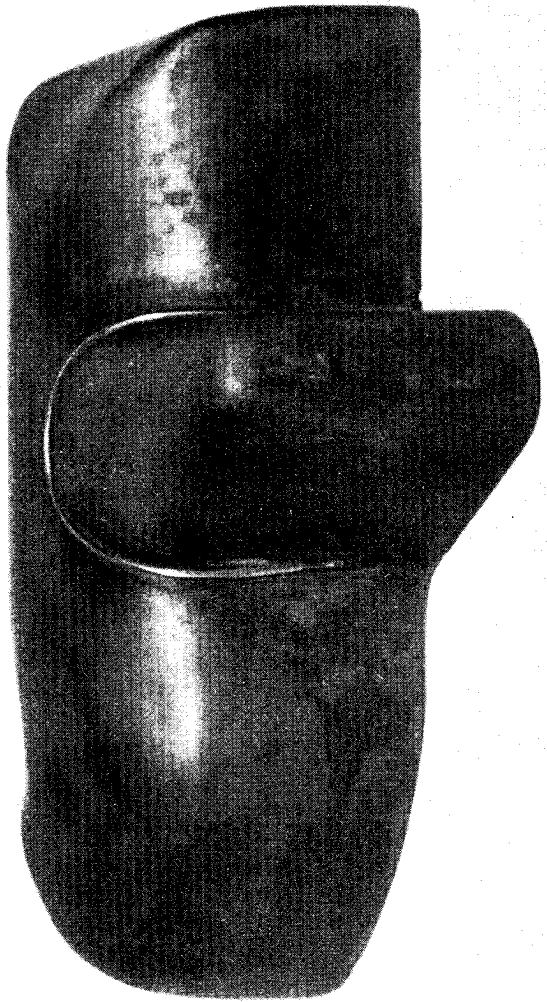

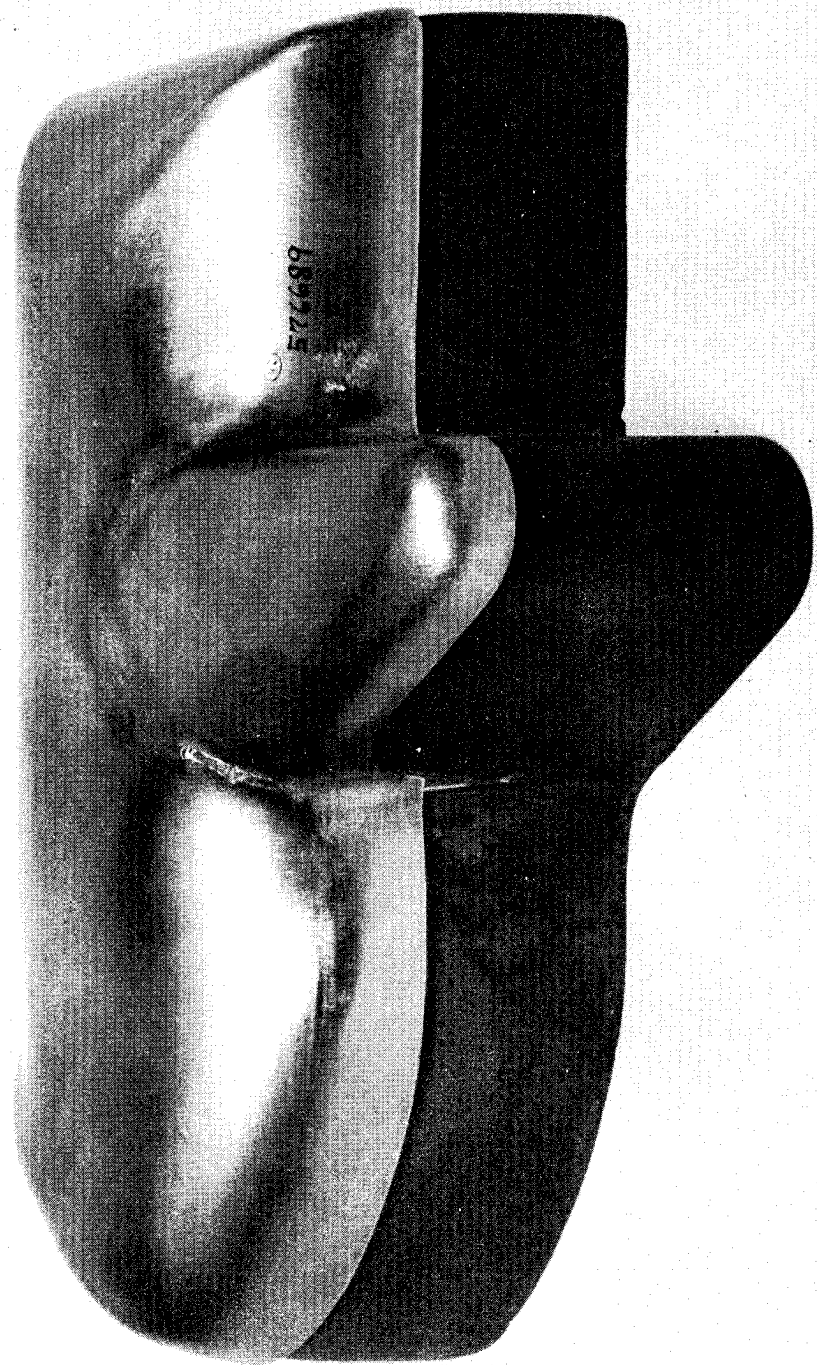

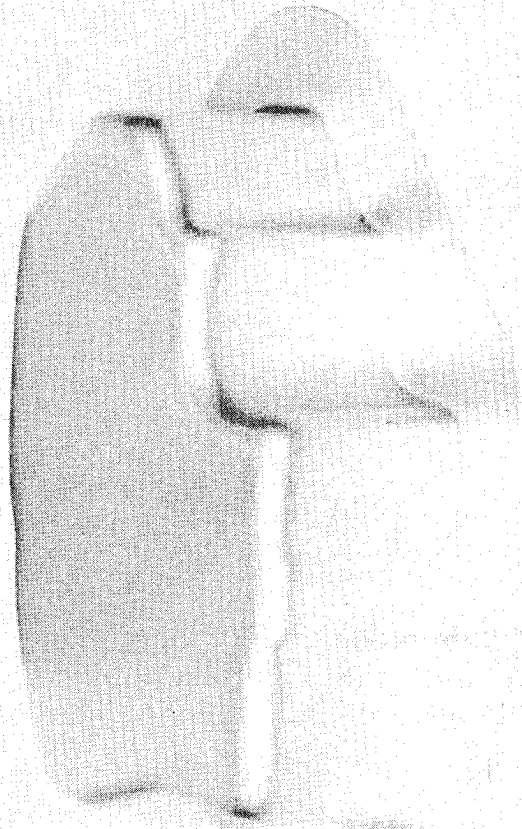
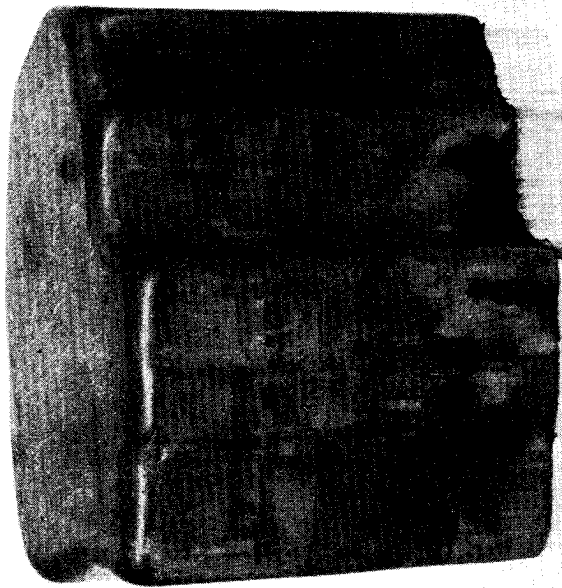

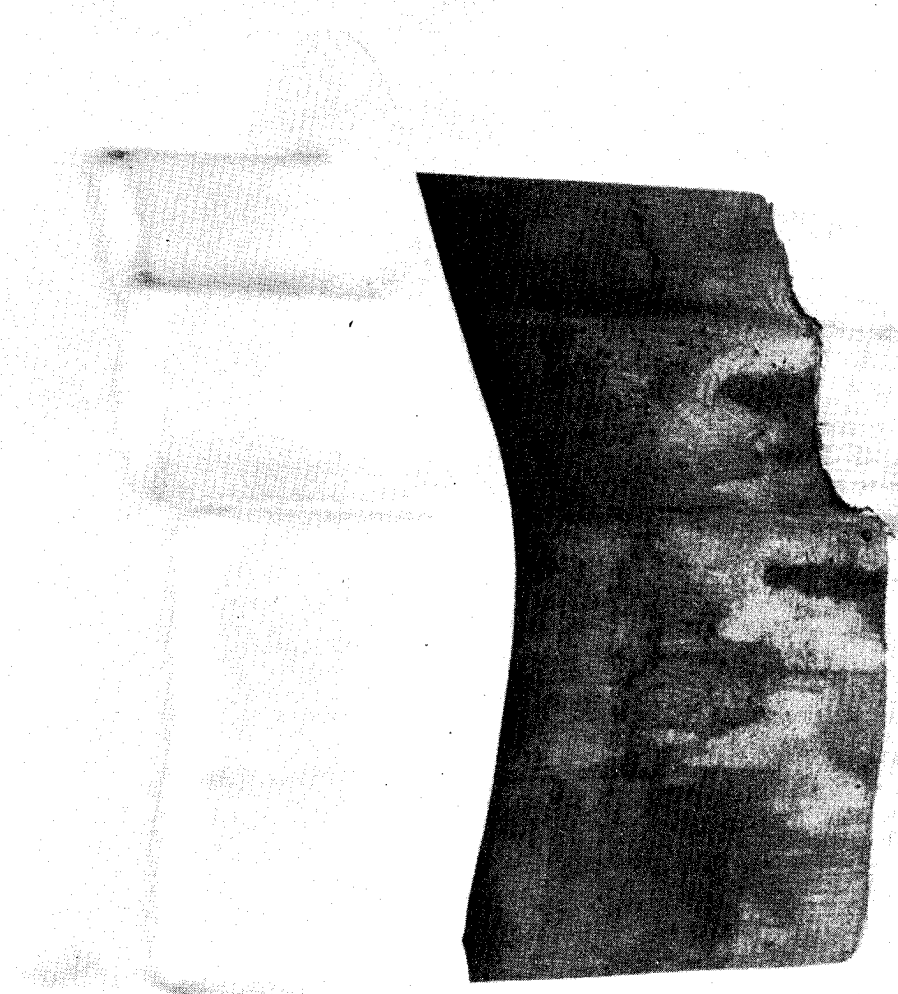

Summary:

All the plastic tools that have been presented, with the exception of the tools used for forming the steel and the last tool presented, have formed a like number of aluminum sheet metal details. The results obtained by using this type of tooling material for the hydroforming process have been excellent. It has been possible, by using this tooling method, to reduce the lead times from concept of the products to the finished articles.

As several design changes were made that affected the various tool configurations it was possible to modify the tools in a short period of time without using the machinery or skills normally associated with the fabrication of hard tooling.

The physical appearance of the tools at this date do not indicate any evidence of wear or breakdown in the forming areas; likewise, no repairing of any tool has been made on any surface including the areas damaged by improper handling or from hand forming on the details.

From the tooling data obtained in this forming program, plastics as a tooling material, will be given consideration as a substitute in all new programs.

PLASTICS FOR TOOLING SEMINAR

June 11, 12, 1964
Thursday - Friday

Purdue University
Lafayette, Indiana

ROSTER

ADKINS, Turner, Supervisor, Methods & Tool Design, National Automatic Tool Company, Inc., National Road West, Richmond, Indiana

ALSPAUGH, S. W., Master Mechanic, Frigidaire Division, GMC, 300 Taylor Street, Dayton, Ohio

AMRINE, H. T., Head, School of Industrial Engineering, Purdue University, Lafayette, Indiana

ANDERSON, Robert, Foreman of Pattern Department, Frigidaire - Dayton, Ohio

ARGABRIGHT, Charles, Manufacturing Process Engineer, National Cash Register, 4300 Hannaford Street, Dayton 39, Ohio

ATCHLEY, Bill, Assistant Manager Tooling & Structures Division, Furane Plastics, Inc., 4516 Brazil Street, Los Angeles, Calif.

ATKINSON, Glenn F., Tooling Research, Flexible Company, Loudonville, Ohio, R. D. # Perrysville, Ohio

AUSTIN, Max, Chief Product Engineer, U.S. Rubber Company, Mishawaka, Indiana

AVERS, W. J., Development Engineer, Western Electric Company, Inc., Department 537, 6200 East Broad Street, Columbus, Ohio

BACKSTRAND, Alvar, Sculptor, Hartland Plastic Division, Amerline Corp. Hartland, Wisconsin

BALDANZA, Nicholas T., Engineer, Department of Defense, U. S. Government, Building #176, Picatinny Arsenal, Dover, New Jersey

BALL, O., Senior Tool Engineer, Delco Radio, 700 East Fermin Street, Kokomo, Indiana

BANKS, Robert, Sales Manager, High Strength Plastics, 1401 West Jackson, Chicago 7, Illinois

BARNEY, Edward L., Technical Service Manager, F. B. Wright Company, 9999 Mercier, Dearborn, Michigan

BARRESI, Frank J., Senior Process Engineer, Ford Motor Company, 4200 Bishop Road, Detroit 24, Michigan

BARUTH, Elmore J., Manager, Chemical Division, Bostrom Corporation, 133 - West Oregon Street, Milwaukee, Wisconsin, 53204

BECKER, Walter E. Jr., Elastomer Specialist, Mobay Chemical Co., Parkway West, Pittsburgh 5, Pennsylvania

BECKSTROM, Herbert, Foreman, House of Plastic, Inc., 735 Carriage Avenue, Cleveland, Ohio

BEDNARSKI, Ted E., Chief Engineer, Wahl Copper Corporation, 2902 North Locust Street, Sterling, Illinois

BIELLENLEWICZ, Ted, Sales Manager, Garzel Plastics, 12800 East 9 Mile Road, Warren, Michigan

BISHOP, Gary E., Process Engineer, McKinnon Industries Limited, Ontario Street, St. Catharines, Ontario, Canada

BOCKBRADER, R. H., Product Engineer, B. F. Goodrich Company, 500 South Main Street, Akron 8, Ohio

BOGART, F., Expert, The Marbelette Corporation, 29 East 8 Mile, Hazel Park, Michigan

BOYD, Gerald C., Product Supervisor, Dow Corning Corporation, Midland,
Michigan

BRAATZ, Willi, Supervisor Development Engineer, Cincinnati Milling
& Crinpiac, Inc., Cincinnati, Ohio

BRALEY, C. W., Tool Design, Allison Division GMC, Indianapolis,
Indiana

BRANDENBURG, Charles, Process Engineer, Adams & Westlake Company,
1025 North Michigan Street, Elkhart, Indiana

BROCK, James R., Representative, Marblette Corporation, 5532 West
Division Street, Chicago 51, Illinois

BROM, Stanley D., Supervisor Plastic Shop, U. S. Rubber Company,
407 North Main, Mishawaka, Indiana

BROWN, Raymond L., Supervisor, A. C. Spark Plug, 3100 North Dort
Highway, Flint, Michigan, (Engineering Bldg. 32-02)

BUTLER, Joseph L., Hone Engineer, National Automatic Tool Company,
National Road West, Richmond, Indiana

BUTTERFIELD, Robert, Manufactures Representative, H. Stark & Son,
16147 Meyers Road, Detroit, Michigan

CALLIS, Sam, Chief Tool Engineer, Brunswick Corporation, Brunswick
Lane, Marion, Virginia

CAMP, Wayne W., Sales Manager, Ren Plastics, 2002 Joffre Avenue,
Toledo, Ohio 43607

CAPRINO, Joseph C., Manager, Rubber Market Development, General Electric
Company, Silicones Product Department, Waterford, New York

CARLISLE, Howard W., Meta-Dynamics Division, Cincinnati Milling
Machine Co., Cincinnati, Ohio

CARON, Lionel, Technical Model Maker Officer, National Research Council
of Canada, Montreal Road, Ottawa, Ontario, Canada

CHAMP, George, Chief Design Engineer, H. O. Canfield Company, Seymour,
Indiana P. O. Box 218

CONDIT, C. L., Technician, Soc. Plastics Industry, 250 Parke Avenue,
New York, New York

CURNOW, Loring M., Senior Exp. Chemist, General Motors Corporation,
Styling Staff, GM Technical Center, Warren, Michigan

DAMES, Al W., Sales Manager, Hastings Plastics, 1704 Colorado Blvd.,
Santa Monica, California

DARRAGH, Joseph M., Regional Manager, Ren Plastics,

DAVIS, Charles H., Manufacturing Engineer, Jas. H. Matthews & Co.,
6515 Pennsylvania Avenue, Pittsburgh, Pennsylvania

DEEHAU, Carl L., Superintendent Tool Room, Rochester Products Div.,
General Motors, 1000 Lexington Avenue, Rochester, New York, 14603

DELMONTE, John, Furane Plastics Inc., Los Angeles, Calif.

DENOMME, Harold, Process Engineer, Chrysler Stamping Group, Outer
Drive Plant, Detroit, Michigan

DIGGLES, Fred, Technical Sales, Magnolia Plastics, Inc., P. O. Box
1235, Santa Monica, California

DONALD, Bruce E., Engineer, The Procter & Gamble Co., P. O. Box 599,
Cincinnati, Ohio

DURFEE, Donald B., Mat'ls. Development Engineer, Chrysler Corporation,
Department 521 - 12800 Oakland, Detroit, Michigan, 48203

ECKARDT, George A., Sales Engineer, Imperial Cutting Tool Company,
4935 Fullerton, Chicago 39, Illinois

ELSEA, Robert E., Tool Development Engineer, Central Foundry Division,
GMC, 37 Florence Street, Saginaw, Michigan

EVANS, R. C., Supervisory Tool & Die, Blue Bird Body Company,
Ft. Valley, Georgia

FERRARI, Edward, Man Model Shop, General Electric, 1285 Boston Avenue,
Bridgeport, Connecticut

FLETCHER, Clifford H., Design Engineer, Brunswick of Canada, 1156
Dundas Highway East, Cooksville, Ontario, Canada

FRICANO, Joseph P., Manufacturing Engineer, Brunswick Corporation,
1700 Messler Street, Muskegon, Michigan

FRID, William V., Product Manager, Armstrong Resins, Inc., & Armstrong
Products Company, Inc., P. O. Box 1, Warsaw, Indiana

FULLARTON, Alan M., Vice President, Calhar Corporation, 4954 Naples
Place, San Diego, California

GELESKO, Nick, Model Shop Manager, Whirlpool Corporation, Laundry
Group, Plant 2, St. Joseph, Michigan

GOODER, G. L., President, Scott Custom Plastics, 1365 Martingrove
Road, Toronto, Canada

GOULD, H. A., Merchandise Manager, U. S. Gypsum Company, 101 S. Wacker
Drive, Chicago 6, Illinois

GRAHAM, Edward J., Tool Engineer, Electro-Motive Division, GMC,
LaGrange, Illinois

GRAHAM R., Senior Engineer, Westinghouse Electric, 16 Pocono Drive,
Pittsburgh, Pennsylvania

GREBE, John Wm., Assistant Manager, Ford Motor Company, Styling
Office, Dearborn, Michigan

HALFPAP, W. E., Toolroom Department Chief, Western Electric Company,
2525 Shadeland Avenue, Indianapolis, Indiana

HAMMOND, Hubert L., General Foreman, Tool & Die, Chevrolet Tonawanda
Forge, Kenmore Avenue, Tonawanda, New York

HARDIN, Darwin L., Research & Development Plastic, Flexible Company,
Loudonville, Ohio

HARRISON, Ben L., General Foreman, Hamilton Standards, A Division of
United Aircraft, Windsor Locks, Connecticut

HAYES, Richard, Pattern Shop Supervisor, Efficient Ind. Corporation,
5514 Old Brecksville Road, Cleveland, Ohio

HERF, Jacob F., Engineering Supervisor, Westinghouse Electric Corp.,
300 Phillippi Road, Columbus, Ohio

HELL, Carl E., Chairman, Plastic Structures Inc., 17439 Lake Avenue,
Lakewood, Ohio

HENRY, J., Department Head, Plastics, Chrysler Corporation, 12800
Oakland, Detroit 3, Michigan

HESSE, Frank L., Briscoe Manufacturing Co., Columbus, Ohio

HODSHIRE, E. B., Manufacturing R & D, Chrysler Corporation, Box 1919,
Detroit, Michigan 48231

HOLST, Henry V., Metallurgist, Chrysler Corporation, Power Train
Group, MR & D, P. O. Box 1919, Detroit 31, Michigan

HOUGH, Richard J., Director of Marketing, Furane Plastics, Inc.,
4516 Brazil Street, Los Angeles, California

ISON, Denver, Plastic Technician, Procter & Gamble, P. O. Box 599
Cincinnati, Ohio

JAMISON, William J., Laboratory Manager, Thermoset Plastics, 5101
East 65th Street, Indianapolis, Indiana

JUERGENSEN, G., Development Engineer, Union Carbide, Linde Division,
1500 Polro Street, Speedway, Indiana

KAISCH, R. H., Division Manager, Rezocin Industries, 35640 South Gratiot, Mt. Clemens, Michigan

KENDELL, James R., Chemist, Technical Service, High Strength Plastics, 1401 West Jackson Street, Chicago, Illinois

KENT, Richard, Pattern Maker, Peerless Pattern, Inc., 312 North McGee Street, Dayton, Ohio

KIGEN, T. A., Sales Service Engineer, Johns-Mansville, River Road, Waterville, Ohio

KIMMELL, Andy, General Manager, Kimmell Engineering Company, Harrisonville, Missouri

KOWALKOWSKI, Chester, Manufacturing Engineer, Sikorsky Aircraft, South Avenue, Bridgeport, Connecticut

KRIZEK, Elmer J., President, House of Plastics, 735 Carnegie Avenue, Cleveland, Ohio

KRUGER, Thomas E., Engineer, General Motors Corporation, Ternstedt Division, 30007 Van Dyke, Warren, Michigan

KRUPP, John L., Senior Draftsman, B. F. Goodrich Co., 500 S. Main Street, Akron, Ohio, 2516 Dalton Rd., Akron, Ohio

LaDOW, William, Chief Designer, Hopple Plastics, Inc., 2370 Reading Road, Cincinnati, Ohio

LAFITTE, George A. Jr., Manufacturing Research Engineer, Sr., Lockheed-Georgia Co., Dept. 47-33, Marietta, Georgia 30061

LAHR, M. L., Tool Engineer, Goodyear Aerospace Corporation, 1210, Massillon Road, Akron, Ohio

LANDGRAF, S. V. Plastic Engineer, Adams & Westlake Co., 1025 North Michigan Street, Elkhart, Indiana

LANGSTON, Charles L., J. P. Stevens Co., New York, New York

LASCOE, O. D., Professor, Industrial Engineering, Purdue University, Lafayette, Indiana

LAWRENCE, Henry M., Senior Tool Engineer, Rochester Products Div. G. M., Rochester 14603 New York, 162 Furlong St., Rochester, N. Y.

LEWIS, Fred H., Process Engineer, Benoix Corp., P. O. Box 1159, Kansas City, Missouri

LEWIS, Robert E., Sales, Meyer Materials, 5101 East 65th Street, Indianapolis, Indiana

LOMBARDO, M. D., Tech. Sales Engineer, The Marblette Corporation, 37-31 30th Street, L. I. C., New York

LUDEMAN, Howard L., Sales Engineer, Imperial Cutting Tools, Inc., 219 Bradley Court, Des Plaines, Illinois

LUNABURG, Dick, Tech. Representative, High Strength Plastic Corporation, 1401 W. Jackson Blvd., Chicago 7, Illinois

MALIS, Ronald, Vice President, Warren Plastics & Engineering, 2120 East 9 Mile Road, Warren, Michigan

MAREACLEN, B. S., Industrial Engineer, Duncan Electric, Lafayette, Ind.

MARTON, Alexander, Senior Group Leader, Sikorsky, South Avenue, Bridgeport, Connecticut

MASSEY, James L., Plant Engineer, Columbian Enameling Co., P. O. Box 66, 12 pt. Station, Terre Haute, Indiana

MATHER, Howard, Engineer, General Electric, Building 69, Rm. 105, Schenectady, New York

MATHER, J. P., Vice President & General Manager, Purdue Research Foundation, Purdue University, Lafayette, Indiana

MAYEDA, Thomas H., Process Engineer, Allisons, Division of General Motors, Inc., Department 5815 - 2025, BC# 8, Indianapolis, Ind.

MCCARDLE, William, Junior Engineer, Plastics Laboratories, Inland Manufacturing Company, Division of General Motors Corp., Plastics Lab., Department 30, 2727 Inland Avenue, Dayton 9, Ohio, 45401

MCCOY, Harry R. Jr., Project Engineer, Brunswick of Canada, Ltd., 1156 Dundas Highway East, Cooksville, Ontario, Canada

McELHANY, Earl, Equipment Engineer, Remington Arms Company, Inc. Lake City Arsenal, Independence, Missouri

McNUTI, Malcolm R., Supervisor Plastics Development, The Gerstenschlager Company, 1425 East Bowman Street, Wooster, Ohio 44692

MENNIG, James M., Research Technician, U. S. Gypsum Company, 1000 East Northwest Highway, Des Plaines, Illinois

MEYER, Norman R., Pattern Maker, Symington-Wayne Corporation, 2 Main Street, Depew, New York

MEYER, Walter, Tooling Foreman, Lunn Laminates, Wyan Danch, Long Island, New York

MICHAELSON, B. L., Section Supervisor, Bendix Corporation, P.O. Box 1159, D/205 Kansas City, Missouri

MILNER, Kenneth, Salesman,, Tool Chemical Company, 29 East 8 Mile Road Hazel Park, Michigan

MINSKER, John H., Plastics Engineer, Dow Chemical Company, Midland, Michigan

MORRIS, Michael A., Kimmell Engineering Company, Harrisonville, Missouri

MORRISEY, Edward J., Mat. & Process Engineer, National Cash Register, Main & K Streets, Dayton, Ohio 45409

MULLIGAN, Charles E., Production Director - 364, U. S. Coast Guard Yard, Curtis Bay, Baltimore, Maryland 21226

NEUMEYER, Charles R., Process Engineer, International Harvester Co., Manufacturing Research - 5225 South Western Blvd., Chicago, Illinois

NOBLETT, Perry, Production Development Engineer, Bell Helicopter, P. O. Box 482, Fort Worth, Texas

NORDSTRAND, Vern, Assistant Superintendent, The Boeing Company, Renton, Washington

OCASEK, Joseph, Engineering Technician, U. S. Naval Ordnance Plant, 7500 West Roosevelt Road, Forest Park, Illinois

PAARLBERG, Don, Professor, Agriculture Economics Department, Purdue University, Lafayette, Indiana

PHILLIPS, C. A., General Foreman, Ford Motor Company, 2127 Morris, Lincoln Park, Michigan

PLETZKE, John V., Supervisor, Market Development, Dow Corning Corporation, Midland, Michigan

POOLE, Don S., Product Planning & Development, The Goodyear Tire & Rubber Company, 1144 East Market Street, Akron, Ohio 44316

POSTON, Irvin E., Section Engineer, General Motors, GM Technical Center, Warren, Michigan

PRIDEAVX, Ronald G., Product Manager, Rezolin Inc., 1651 18th Street, Santa Monica, California

QUINLAN, John, Working Group Leader, Taylor Winfield Corporation, Mahoning Avenue, Warren, Ohio

RALSTON, Gene, Specialist - Plastics General Electric Computer Department, 13430 North Black Canyon, Phoenix, Arizona

REIMER, Richard L., Sales Engineer, U. S. Gypsum Company, 3901 Meadows Drive, Room B8, Indianapolis, Indiana

RENGERT, James A., President, Blehm Plastics, 608 East 10 Mile Road, Hazel Park, Michigan

RESKE, Edward, Foreman, U. S. Rubber Company, 307 North Hill, Mishawaka, Indiana

RICHE, F. R., President, Rezolin - France, S. A. 3 Bis Rue M. Monge, Suresnes (Seine) France

RICKE, William H., Representative, Rezolin, Inc., 917 West Central Blvd., Orlando, Florida

RIDD, W. J., Senior Engineer, Frigidaire Division GMC, 300 Taylor Street, Dayton, Ohio

RIPPE, Jay J., Engineer, General Electric, 1635 Broadway, Bldg. 17-2, Fort Wayne, Indiana

RITTER, G. R., General Foreman, U. S. Rubber Company, Mishawaka, Indiana

ROBINSON, George K., General Supervisor 6-3750, Boeing Airplane Company, 7035 South 127th Street, Seattle, Washington 98178

ROHDE, Armin, Model Maker, Hartland Plastics, Division Amerline Corp., Hartland, Wisconsin

RONGEY, Clarence H., Master Mechanic, Killark Electric Company, 3940 Easton Avenue, St. Louis 13, Missouri

ROSENSTICL, Frank M., Foreman - Tooling, Northrop Corporation, Norair Division, Hawthorne, California

RUGGLES, Cleve, R & D Engineer, Brunswick Corporation, Marion, Virginia

RUMPEL, L. J., Technical Assistant to Director of Purchasing, J. I. Case, 700 State Street, Racine, Wisconsin

SAAGH, Mike, Scott Plastics, 1365 Martingrove Road, Rexdale, Ontario, Canada

SANTONI, Joseph P., Supervisor, Ford Motor Company, Oakwood Avenue, Dearborn, Michigan

SHELL, Henry A., Manager - Industrial Division, A. Wimpfheimer & Brothers, Stonington, Connecticut

SCHULTE, S. A., Sales & Service, Magnolia Plastics, Inc., 5547 Peachtree, Industrial Blvd., Chamblee, Georgia

SCHUMAL, Michael J., Tool Engineer, Electro Motive Division, GMC, 900 East 103rd Street, Chicago, Illinois

SEIBERT, Jewell L., Tool & Process Engineer, National Cash Register, N.C.R. Main & K Streets, Dayton, Ohio

SHEBEL, F. C., Plastics Engineer, Crouse - Hinds Company, Wolf & 7th North Streets, Syracuse, New York

SHROYER, Harold F., Vice President, Full Mold Process, Inc., 711 Devon, Park Ridge, Illinois

SKELLY, William C., Senior Project Engineer, General Motors Styling, 12 Mile & Mound, Warren, Michigan

SMITH, Dale J., Treasurer, Allen-Hayeslt Industries, 11350 Kaltz, Warren, Michigan

SMITH, William A., Engineer, Libbey-Owens-Ford, Rossford, Ohio

SNYDER, Charles W., Technical Sales Department, CIBA Products Company, Rt. 208, Fair Lawn, New Jersey

STARK, Walter M., President, Stark & Sons, 16147 Meyers Road, Detroit, Michigan 48235

STEPHENSON, Harry, Sales Manager, Ren Plastics, 1606 Barns Dale, LaGrange Park, Illinois

STRAND, Norman S., Chemist, Dow Chemical Company, PD & S, Midland, Michigan

STROHACKER, LaVern E., Pattern Supervisor, James B. Clow & Sons,
Coshoeton, Ohio

STRONACH, Laurie G., Manufacturing Process Engineer, Ford Motor
Company, 3978 Vassar, Dearborn Heights, Michigan

SUMNER, Earl C., Plastics Laboratories Manager, The Duriron Company,
Inc., Box 1019, Dayton 9, Ohio

SWARTZENTRUBER, Merle, Tool Designer, Mandrels, Inc., 620 North
Chapel Street, Louisville, Ohio

TABOR, Carl J., Owner, Carl J. Tabor Plastics, 2817 Park Avenue,
St. Louis 4, Missouri

TABOR, James E., Apprentice, Carl J. Tabor Plastics, 2817 Park Avenue,
St. Louis 4, Missouri

TEETOR, J. H., Sales Representative, Thermoset Plastics, 4384 Fieldbrook,
Orchard Lake, Michigan

THOMPSON, Clinton, Foreman, Thiokol Chemical Corporation, Providence,
Utah

THOMPSON, Irwin F., Foreman, Pontiac Motor Division Engineering,
Joslyn Avenue, Pontiac, Michigan

TIERNEY, Joseph, Sales Manager (Tooling Division) Hysol Corporation,
1100 Seneca Avenue, Olean, New York

TOMCHUCK, Arthur M., Superintendent, Ford Motor Company, 13950 Dixie,
Detroit, Michigan 48239

TONKOVICH, Andrew M., Supervisor, Ford Motor Company, 5611 Whispering
Oak, Birmingham, Michigan

VANKAR, Richard, Foreman, Wettlaufer Engineering, 2400 East 9 Mile
Road, Warren, Michigan

VAUGHAN, W. L., Field Sales Manager, U. S. Gypsum, 101 South Wacker
Drive, Chicago, Illinois

VENABLE, P. L., Tool Engineer, Norair-Division Northrop Corporation,
Hawthorne, California

WAGNER, Donald M., Design Engineer, General Electric Company, Nela Park
#235, Cleveland 12, Ohio

WALSH, Dave, Sales Engineer, Rezolin, 35640 South Gratiot, Mt. Clemens,
Michigan

WALSH, William R., Supervisor Tool Design, Fisher Body Division, GMC,
30001 VanDyke, Warren, Michigan

WATERS, Floyd, Jr., Senior Process Engineer, Allison Division, GM,
Plant 8, Department 5827, Indianapolis, Indiana

WAYNE, Mitchell, Manager, Body Tooling Aids Department, Ford Motor
Company, 44031 Brookwood Drive, Northville, Michigan

WEAVER, H. R., Senior Product Engineer, B. F. Goodrich Company,
Aerospace and Defence Products Division, 500 South Main Street,
Akron 18, Ohio

WEAVER, W. R., President, Modern Pattern & Plastics, 2113 Canton
Avenue, Toledo, Ohio

WELCH, Marty, Tooling Supervisor, Excel Pattern Works, Inc., 7020
Chase Road, Dearborn, Michigan

WELLS, Don, Magnolia Plastics, Inc., 5547 Peachtree, Industrial Blvd.,
Chamblee, Georgia

WENK, Gene G., Engineer, Brunswick Corporation, 1700 Messler Street,
Muskegon, Michigan

WHINNERY, Lewis A., Tool & Production Engineer, Reinforced Plastics
Division, Everbrite Electric Sign Company, 315 Marion Avenue,
South Milwaukee, Wisconsin

WHITEHEAD, M. H., Manager, R & D, Columbian Enameling & Stamping Co.,
P. O. Box 66, 12 pts. Station, Terre Haute, Indiana
WHITE, Otis, Plastics Engineer, Department 37, Beech Aircraft Corp.,
East Central Avenue, Wichita, Kansas 67201
WIARD, E. H., Director, Marketing, Ren Plastics, 5656 South Cedar,
Lansing, Michigan
WIKELSKI, Karl W., Sales Engineer, Union Carbide Corporation, Linde
Division, 1245 Main Street, Indianapolis 24, Indiana
WILLIAMS, Lowell E., Chemist, Thermoset, 5101 East 65th Street,
Indianapolis, Indiana
WINKLER, Walter, Engineer, Technical, Naval Ordnance Plant, 7500 West
Roosevelt Road, Forest Park, Illinois
WRIGHT, Arthur D., Senior Project Engineer, Brunswick Corporation, 1700
Messler Street, Muskegon, Michigan
WRIGHT, Val. Midwest Editor, Modern Plastics Magazine, 645 North Michigan
Avenue, Chicago 11, Illinois
YIRIGOYEN, Frank, Avnet-Shaw, Plainview, L.I., New York
YOUNG, H. H., Professor, Purdue University, Lafayette, Indiana
YOUNG, Melvin, Products Manager, U. S. Gypsum Company, 101 South
Wacker, Chicago, Illinois