

Lawrence Livermore Laboratory

The Effect of Stress on the Fluorescence of Kevlar Fiber

J. H. Richardson, G. R. Haugen, L. S. Penn, J. H. Feikert, and R. J. Sherry

October 18, 1976

19951107 110

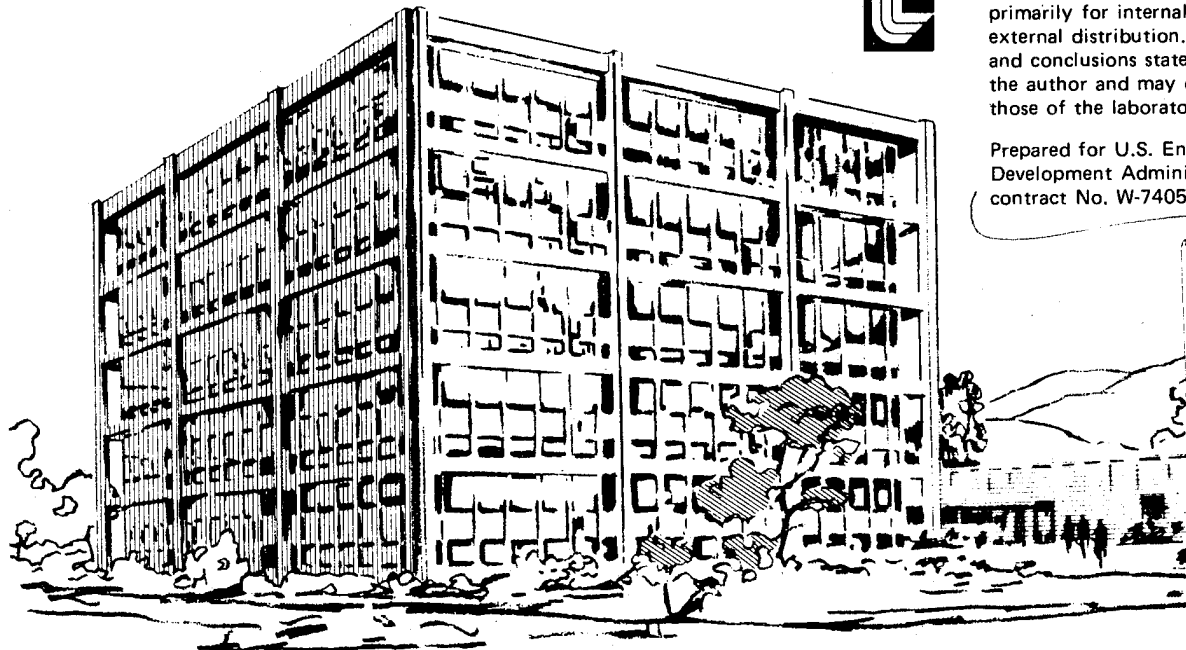
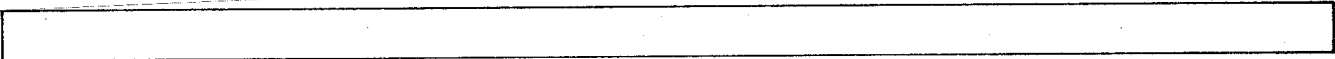
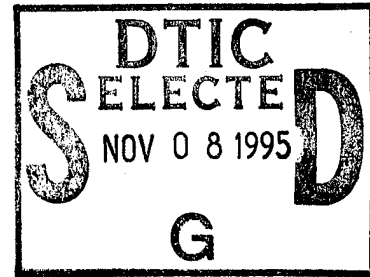

This is an informal report intended primarily for internal or limited external distribution. The opinions and conclusions stated are those of the author and may or may not be those of the laboratory.

Prepared for U.S. Energy Research & Development Administration under contract No. W-7405-Eng-48.

DISTRIBUTED 27799

DISTRIBUTION STATEMENT A

Approved for public release;
Distribution Unlimited

DTIC QUALITY INSPECTED 5

*MSG DI4 DROLS PROCESSING - LAST INPUT IGNORED

-- 1 OF 1

DTIC DOES NOT HAVE THIS ITEM

-- 1 - AD NUMBER: D424001
-- 5 - CORPORATE AUTHOR: CALIFORNIA UNIV LIVERMORE LAWRENCE LIVERMORE LAB
-- 6 - UNCLASSIFIED TITLE: THE EFFECT OF STRESS ON THE FLUORESCENCE OF
-- KEVLAR FIBER,
--10 - PERSONAL AUTHORS: RICHARDSON ,J. H. ;HAUGEN ,G. R. ;PENN ,L. S. ;
-- FEIKERT ,J. H. ;SHERRY,R. J. ;
--11 - REPORT DATE: OCT 18, 1976
--12 - PAGINATION: 16P
--14 - REPORT NUMBER: UCID-17333
--15 - CONTRACT NUMBER: W-7405-ENG-48
--20 - REPORT CLASSIFICATION: UNCLASSIFIED
--22 - LIMITATIONS (ALPHA): APPROVED FOR PUBLIC RELEASE; DISTRIBUTION
-- UNLIMITED. AVAILABILITY: NATIONAL TECHNICAL INFORMATION SERVICE,
-- SPRINGFIELD, VA. 22161. UCID-17333.
--33 - LIMITATION CODES: 1 24

-- END Y FOR NEXT ACCESSION END

Alt-Z FOR HELP3 ANSI 3 HDX 3 3 LOG CLOSED 3 PRINT OFF 3 PARITY

THE EFFECT OF STRESS
ON THE FLUORESCENCE OF KEVLAR FIBER*

J. H. Richardson, G. R. Haugen, L. S. Penn
J. H. Feikert, and R. J. Sherry

University of California
Lawrence Livermore Laboratory
Livermore, California 94550

October 15, 1976

I. INTRODUCTION

Q Kevlar, an aromatic polyamide fiber made by DuPont, is enjoying great popularity because of its excellent mechanical properties. This fiber finds many applications but is of particular use in Kevlar/epoxy composite materials and parts such as filament wound pressure vessels. Ultimately there is interest in predicting the lifetime of these pressure vessels under stress and assorted environmental conditions. Since the fiber has only been available for about five years, there is no long term performance data which has been experimentally determined under realistic field conditions. The lack of a predictive molecular model makes it difficult to directly correlate an experimental observation with an estimation of lifetime. An understanding, on a molecular level, of failure and of the changes associated with long term aging would greatly contribute to formulating an accurate and comprehensive model for predicting lifetime of the material.

Fluorescence techniques have long been shown to be of assistance in investigating molecular structure, conformation changes, dynamics, and even

* This work performed under the auspices of the U. S. Energy Research and Development Administration under contract No. W-7405-Eng-48.

Accession For	
NTIS	CRA&I <input checked="" type="checkbox"/>
DTIC	TAB <input type="checkbox"/>
Unannounced	<input type="checkbox"/>
Justification	
By	
Distribution/	
Availability Codes	
Dist	Avail and/or Special
A-1	

stress-strain phenomena¹ in solids. The advent of laser induced molecular fluorescence greatly augments the power of fluorescence techniques (improved frequency and temporal resolution, spatial coherence, and photon flux). Consequently, we have initiated a preliminary feasibility study to determine if laser induced fluorescence might reveal any of the molecular details associated with applying a uniaxial stress to Kevlar fibers. Although largely motivated by empiricism, the general applicability of laser induced fluorescence techniques, the projected compactness of lasers, and the associated spatial selectivity of lasers suggest that eventually laser induced fluorescence might be a useful, in situ diagnostic monitor of Kevlar/epoxy composite parts. It is conceivable that ultimately a fluorescence observable could be correlated to a use-related variable such as stress-level or environmental conditions. Such correlations would eventually enable more accurately predicted lifetimes of composite parts to be made.

II. EXPERIMENTAL

The following materials were used as samples: 1) sections of Kevlar 49 fiber, all taken from the same spool; 2) cured epoxy resin; 3) the Kevlar 49/epoxy resin composite. The epoxy resin used was the diglycidyl ether of bisphenol A cured with Jeffamine T-403, an aliphatic amine hardener. Fiber composite samples consisted of cured, resin-impregnated strands of Kevlar 49.

Figure 1 is a schematic of the experimental apparatus. The excitation source was a Molectron UV 1000 N₂ laser and Molectron dye laser operated in the DL 200 configuration. The laser was operated at 40 pps; typical peak powers were 1 KW with approximately 8 ns bandwidth (FWHM). The monochromator, a Jobin-Yvon H-20 f/3.5 was used with matched 2 mm slits (8 nm FWHM). Typically the RCA 8850 PM tube was operated at 1300 V; a neutral density filter was used to attenuate the signal when measuring the intensity of the scattered light. Signal averaging was done with a PAR Model 162/163 dual channel boxcar equipped with S-5 sampling heads (1 ns risetime). Details of the experimental apparatus have been previously published.²

The sample chamber was modified to accommodate the Kevlar strands. The strands were clamped on each end between two aluminum plates with adhesive. Clamping was done with the aid of a jig for good alignment and uniformity from sample to sample. The aluminum clamps were used to securely fasten one end of the fiber to the bottom of the sample chamber, the other end being similarly fastened to a large piston (30.4 cm²). The pressure on the piston could be incrementally increased by 0.002 Kg/cm². Data was routinely taken every 0.05 Kg/cm²; the fibers usually broke between 0.25 and 0.30 Kg/cm². The entire sample chamber was light tight and purged with dry nitrogen or

argon. Alignment of the fiber strand and laser beam was accomplished with the beam shaping optics external to the sample chamber.

Absorption spectra were taken using a Cary 14 of both the Kevlar strands and the epoxy resin used in the composite (DER 332/T-403). The resin was transparent above 400 nm; its absorption slowly increased below 400 nm, having a maximum below 300 nm. The Kevlar strands exhibited a broad maximum at ca. 300 nm and a more intense sharper maximum at 240 nm.

Identical fluorescence spectra of Kevlar (Figure 2) were obtained with either 2-(4-biphenyl)-5-phenyl-1,3,4-oxadiazole (PBD) at 375 nm or frequency-doubled rhodamine 6G at 290 nm. In each case the maximum occurred at ca. 490 nm. The majority of data was taken by exciting at 290 nm; in all cases the fluorescence was monitored at 490 nm. The resin did not fluoresce above 400 nm when excited at 290 nm; weak fluorescence was noted, however, around 312 nm.

The fluorescence lifetime of pulverized Kevlar was measured using a modified Ortec nanosecond fluorometer (the Kevlar fiber fluorescence lifetime was too short to distinguish the fluorescence from the Molectron dye laser pulse). Fibers were shredded, powdered at 77°K, and then mixed and pressed with KBr to form a pellet.

III. RESULTS

There was no noticeable change in the fluorescence spectrum of any level of stress up to the breaking point. The fluorescence intensity I_F , however, relative to the scatter intensity I_S did appear to vary with applied tension. The results of these measurements are summarized in Table I. All ratios were normalized to the zero or low stress value. The stress at which the fiber broke is also included in Table I. The best results are plotted in Figure 3. In all but two instances the trend was toward an increase in the relative fluorescence to scatter ratio. The last three samples (7-9) were epoxy resin coated. It appears that the magnitude of fluorescence increase is attenuated by the resin, although the trend towards a greater fluorescence intensity is still noticeable. The resin has no absorption at 490 nm and negligible absorption at 290 nm; hence, its effect on the I_F/I_S ratio probably reflects a molecular influence.

A number of data points were excluded because the strands were poorly epoxyed to the clamps. Some of those samples had been stored in a humid atmosphere (wet nitrogen was used to purge the sample chamber in that case). Although the excluded data in general was scattered (due probably to slippage of the fiber in the clamp), there was no noticeable difference in the range of I_F/I_S values between the dry and wet fibers.

There was a noticeable degradation of the fluorescence signal upon irradiation if the system was not purged with nitrogen or argon. However, excluding oxygen eliminated this loss in signal. Fibers which were not irradiated broke at the same stress level as those which were irradiated under an inert atmosphere. These observations are consistent with those previously reported³ for the influence of uv radiation on Kevlar. Despite high peak powers, the low average

power (400 μ W), short total exposure time (less than 10 minutes) and the small diameter of the fiber strand relative to the beam diameter imply that the total number of photons impinging the small was relatively low. Consequently, the uv sensitivity has no measurable influence on these experiments or the validity of any conclusions drawn from these experiments.

The lifetime of Kevlar, measured in KBr pellets was found to be ≤ 3 nS. The decay curve was found to be wavelength dependent, and the fluorescence could not be definitely attributed to only one species on the basis of the measured decay curves. The addition of two drops of water to the KBr pellets reduced the lifetime to ≤ 2 nS. The following fluorescent lifetimes were measured for Kevlar dissolved in concentrated H_2SO_4 : $\tau(450-470 \text{ nm}) < \tau(490-510 \text{ nm}) < \tau(510-530 \text{ nm}) \sim 4$ nsec, $\tau(430-800 \text{ nm}) \sim 6$ nS. No attempt was made to see how this lifetime varied with stress; it is impossible to apply a uniaxial, known varying stress to a KBr pellet.

Changing the beam position had a significant effect on the I_F/I_S ratio. Generally this was initially maximized, and once under significant tension the optimal beam position did not vary. One way to minimize the effect of this variable, and simplify data interpretation, would be to use single filaments (12 μ thick) instead of strands. Ample signal was obtained when single filaments were used, but the apparatus was too crude to slowly increase the tension. The minimum force which could be applied was 0.59 newtons (60 g), and hence, no I_F/I_S versus applied stress data could be obtained.

IV. DISCUSSION

Fluorescence is a sensitive probe of a molecule and its environment. Wavelength, intensity, and lifetime are three parameters which are frequently measured to yield the desired information about a molecule. Thus, in addition to interpreting the results already obtained, it also behooves a feasibility report to suggest new or additional experiments which can be considered from the viewpoint of these parameters.

It is relatively unlikely that stressing a fiber will lead to a major shift in fluorescence wavelength (the fluorescence spectrum of Kevlar is ca. 100 nm FWHM), although changes in vibrational spectra are observed in polymers upon stressing. The intuitively pleasing particle in a box concept is less appropriate for large molecular systems with a high density of occupied states; simply lengthening the fiber will probably have little effect on the electronic energy levels. However, CNDO calculations are relatively sophisticated and tractable for this type of problem. Such calculations could be attempted for a model fiber system. Points to be investigated would include bond deformation, hydrogen bonding molecular conformations, nearest neighbor proximity and spatial configuration, and polymer chain length. Although absolute values would not be obtained, predictive trends in expected emission spectra might be revealed.

Both intensity and lifetime changes are indicative of the molecular environment. Non-radiative decay and energy transfer mechanisms (e.g. Förster type transfer) are a function of nearest neighbor proximity and configuration, as well as molecular conformation.⁴ Stressing and hence aligning neighboring Kevlar strands undoubtedly effects these processes; the fluorescence intensity (and lifetime) would be expected to rise as the molecular order increases and

random orbital overlaps diminish. For comparison, impurities in crystals provide the primary quenching mechanisms of excitons, and a quasi-ordered array of linear polymers is a crystalline-like material.⁵ The structure of the crystalline portions is indicated in Figure 4.⁶ Finally, it has also been suggested⁵ that secondary bonding between polymer chains contributes to the comparatively high transverse strength of Kevlar (relative to other similar fibers). This is merely another manifestation of the importance of the molecular environment on the macro-physical properties of Kevlar.

Several possible experiments might be proposed to more fully investigate the intermolecular environment through a study of the fluorescence intensity and lifetime. The fiber lifetime should also be investigated as a function of stress (this would require modification of the Ortec sampling chamber). Experiments with filaments are less subject to laser spatial effects and uneven loading; hence, the intensity measurements might be repeated with filaments. While fluorescence itself is insensitive to hydrogen bonding, the inter- and intra-molecular quenching of fluorescence is strongly dependent on the conformation of the macromolecule.⁷ The accessibility of a quencher (e.g., oxygen, nitrogen oxides) to the chromophore moiety would be a function of hydrogen bonding, molecular order, and probably ultimately applied stress. Of course, laser Raman studies might directly give information on the degree and extent of hydrogen bonding and conformational changes as a function of applied stress.⁸ Finally, the dependence of these fluorescence parameters might also be studied as a function of temperature; such results might have some bearing on the validity of accelerated aging studies.

While not directly of predictive value in determining stress-rupture lifetimes, the above described experiments and calculations would help to elucidate behavior under stress and the mechanism of fracture. Only with

a clear understanding of such stress-rupture phenomena from a molecular basis
can a useful predictive model be constructed which will be of real value.

REFERENCES

1. J. G. Calvert and J. N. Pitts, Photochemistry (John Wiley and Sons, New York, 1966), p. 273.
2. J. H. Richardson, B. W. Wallin, D. C. Johnson, and L. W. Hrubesh, Anal. Chem. Acta., in press.
3. W. L. Harper and C. E. McAlister, Y-12 Development Division Technical Progress Report, Y-1910-8, p. 20, SRD, Union Carbide Corporation, Oak Ridge, TN.
4. J. G. Calvert and J. N. Pitts, Photochemistry (John Wiley and Sons, New York, 1966) pp. 293-366.
5. K. L. DeVries and B. A. Lloyd, "Analytical Studies of Molecular Mechanisms of Polymer Fracture," Final Report, contract No. DAAG 46-73-C-0251.
6. L. Penn and G. Smith, unpublished work (1976).
7. J. R. Lakowicz and G. Weber, Biochemistry 12, 4161 (1973).
8. L. Penn, B. Morra, and F. Milanovich, "Laser Raman Investigations of Kevlar Fiber," to be published.

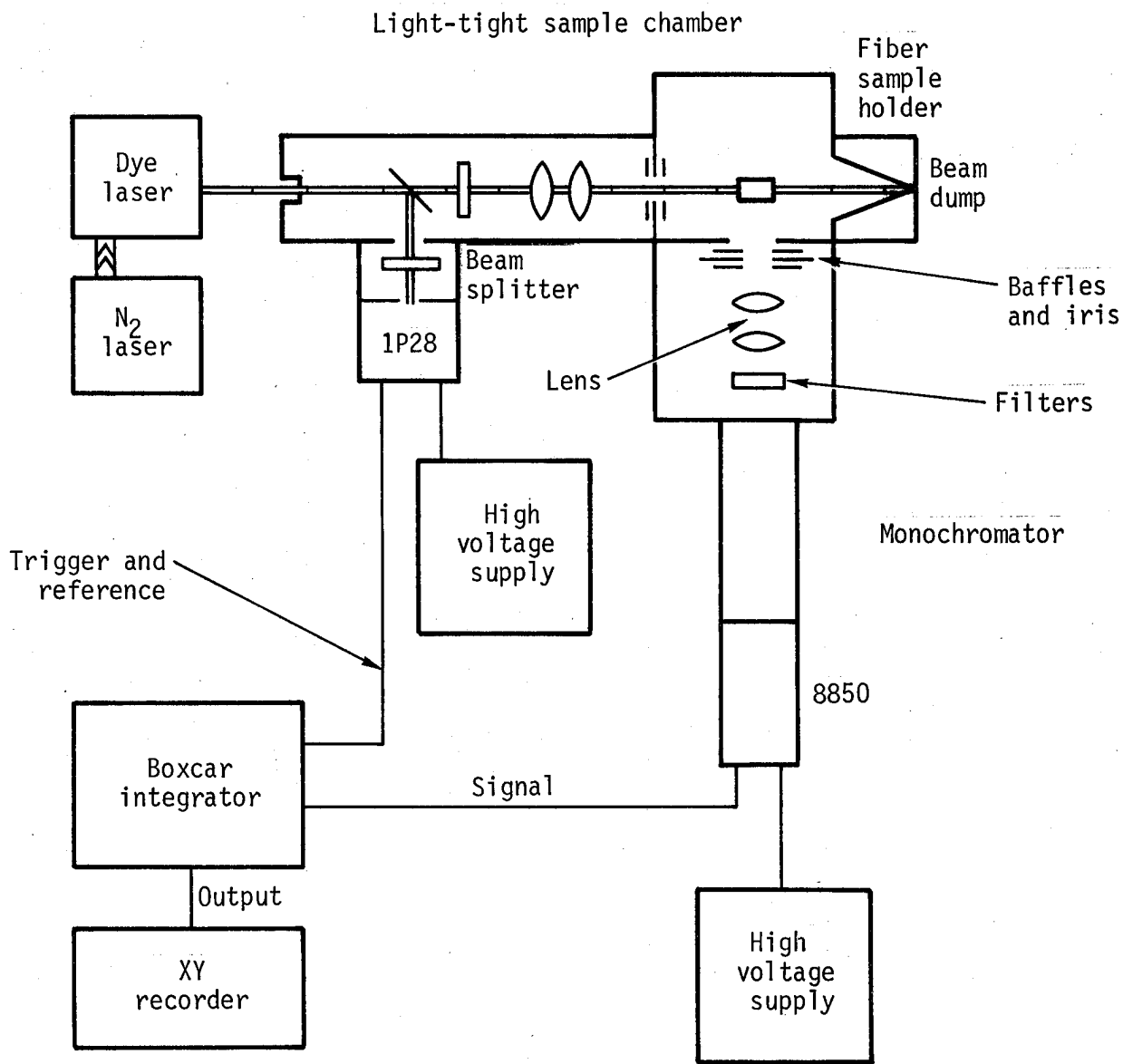

Figure 1. Schematic of experimental apparatus.

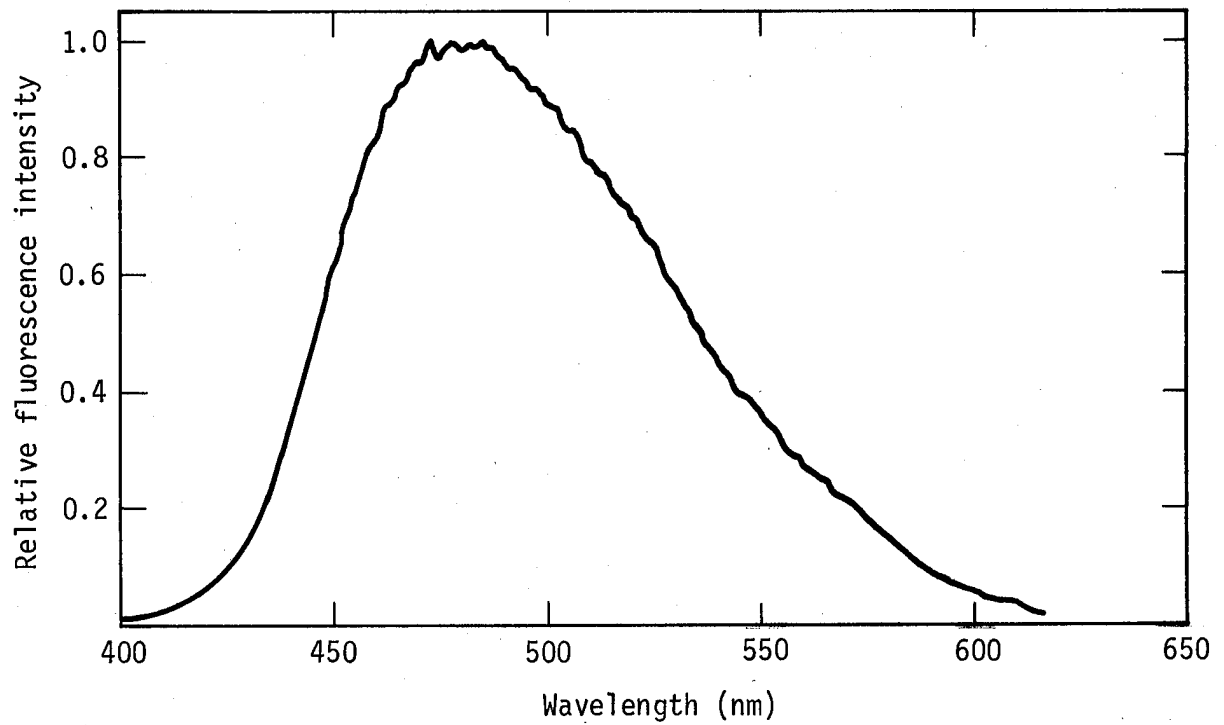

Figure 2. Fluorescence spectrum of Kevlar 49. Excitation wavelength was 290 nm.

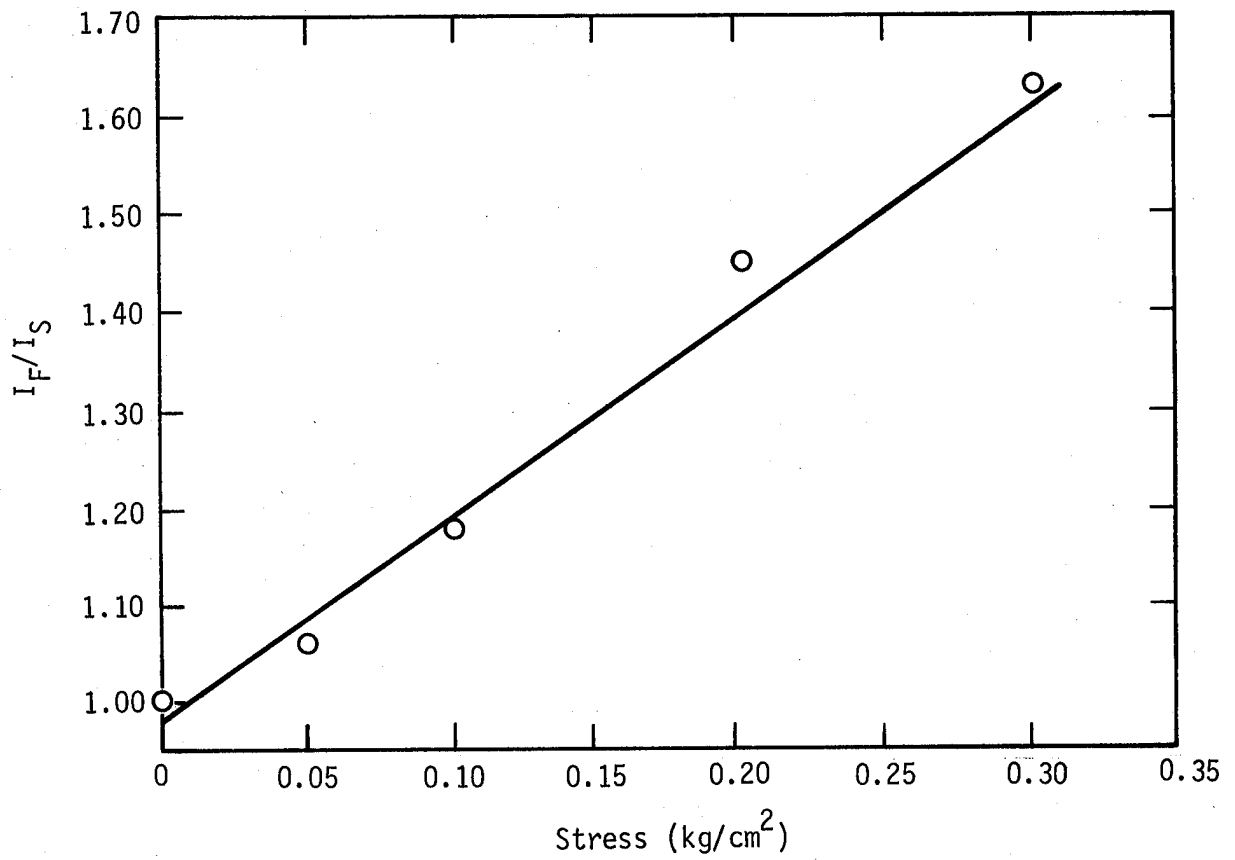

Figure 3. Ratio of fluorescence intensity to scattering (I_F/I_S) versus applied stress. The fluorescence ratio is normalized to the zero stress value.

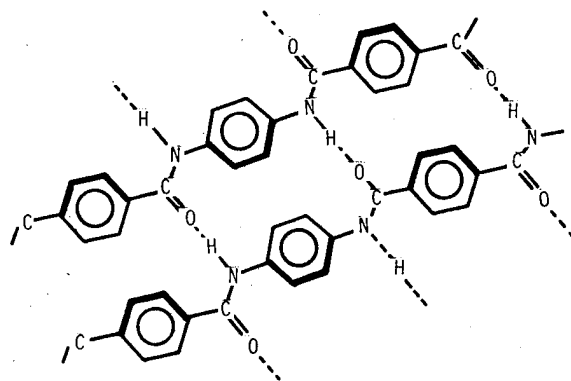

Figure 4a. Structure of Kevlar 49.

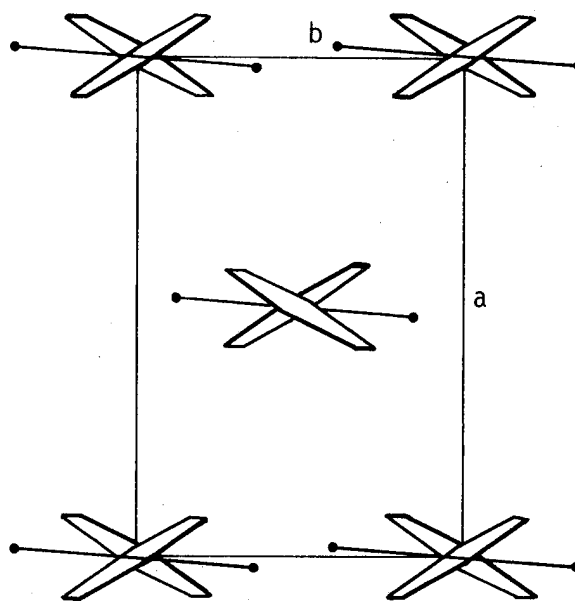

Figure 4b. Packing of the chains in the unit cell. Projection parallel to the c axis (M. G. Northolt and J. J. van Aartsen, *Polymer Lett.* 11, 333 (1973)).

Table I. Ratio of Fluorescence Intensity to Scatter Intensity vs. Stress. No. 7-9 were Epoxy Coated. () is Breaking Stress in Kg/cm²

I_F/I_S

Stress Kg/cm ² \ Sample No.	1	2	3	4	5	6	7	8	9
0.00	1.00	1.00		1.00	1.00	1.00		1.00	
0.05	1.06		1.00	1.12	1.09	0.99	1.00	.99	1.00
0.10	1.18	1.10	1.04	1.23	0.85	0.92	1.02	1.07	1.19
0.15				1.63	0.99	0.89	1.02	1.08	1.17
0.20	1.45	1.15	1.09	1.84	0.94	0.88	1.06	1.06	1.21
0.25			1.03	2.18	0.97	0.92	1.07	1.08	1.21
0.28				2.38 (0.28)	(0.28)	(0.28)			(0.29)
0.30	1.63 (0.32)	1.15 (0.35)	1.54 (0.32)				1.10 (0.35)	1.07 (0.30)	

NOTICE

This report was prepared as an account of work sponsored by the United States Government. Neither the United States nor the United States Energy Research & Development Administration, nor any of their employees, nor any of their contractors, subcontractors, or their employees, makes any warranty, express or implied, or assumes any legal liability or responsibility for the accuracy, completeness or usefulness of any information, apparatus, product or process disclosed, or represents that its use would not infringe privately-owned rights.

NOTICE

Reference to a company or product name does not imply approval or recommendation of the product by the University of California or the U.S. Energy Research & Development Administration to the exclusion of others that may be suitable.

Printed in the United States of America
Available from
National Technical Information Service
U.S. Department of Commerce
5285 Port Royal Road
Springfield, VA 22161
Price: Printed Copy \$; Microfiche \$2.25

<u>Page Range</u>	<u>Domestic Price</u>	<u>Page Range</u>	<u>Domestic Price</u>
001-025	\$ 3.50	326-350	10.00
026-050	4.00	351-375	10.50
051-075	4.50	376-400	10.75
076-100	5.00	401-425	11.00
101-125	5.50	426-450	11.75
126-150	6.00	451-475	12.00
151-175	6.75	476-500	12.50
176-200	7.50	501-525	12.75
201-225	7.75	526-550	13.00
226-250	8.00	551-575	13.50
251-275	9.00	576-600	13.75
276-300	9.25	601-up	*
301-325	9.75		

*Add \$2.50 for each additional 100 page increment from 601 to 1,000 pages;
add \$4.50 for each additional 100 page increment over 1,000 pages.