

Standard Bibliographic Page

1. Report No. NASA CR-4084		2. Government Accession No.		3. Recipient's Catalog No.	
4. Title and Subtitle The Surface Properties of Carbon Fibers and Their Adhesion to Organic Polymers				5. Report Date July 1987	
				6. Performing Organization Code	
7. Author(s) W. D. Bascom and L. T. Drzal				8. Performing Organization Report No.	
9. Performing Organization Name and Address Hercules Aerospace Magna, UT 84044				10. Work Unit No. 505-66-41-04	
				11. Contract or Grant No. NAS1-17918	
12. Sponsoring Agency Name and Address National Aeronautics and Space Administration Washington, DC 20546-0001				13. Type of Report and Period Covered Contractor Report	
				14. Sponsoring Agency Code	
15. Supplementary Notes Langley Technical Monitor: J. A. Hinkley W. D. Bascom: Hercules Aerospace, Magna, Utah (presently at University of Utah, Materials Science and Engineering Department, Salt Lake City, Utah 84112) L. T. Drzal: Michigan State University, East Lansing, Michigan 48823					
16. Abstract The state of knowledge of the surface properties of carbon fibers is reviewed, with emphasis on fiber/matrix adhesion in carbon fiber reinforced plastics. Subjects treated include carbon fiber structure and chemistry, techniques for the study of the fiber surface, polymer/fiber bond strength and its measurement, variations in polymer properties in the interphase, and the influence of fiber matrix adhesion on composite mechanical properties. Critical issues are summarized and research recommendations are made.					
17. Key Words (Suggested by Authors(s)) Carbon fibers Fiber/matrix adhesion Organic matrix composites			18. Distribution Statement Unclassified - Unlimited Subject Category 24		
19. Security Classif.(of this report) Unclassified		20. Security Classif.(of this page) Unclassified		21. No. of Pages 96	22. Price A05

ADD 441 229

NASA Contractor Report 4084

The Surface Properties of Carbon Fibers and Their Adhesion to Organic Polymers

W. D. Bascom and L. T. Drzal

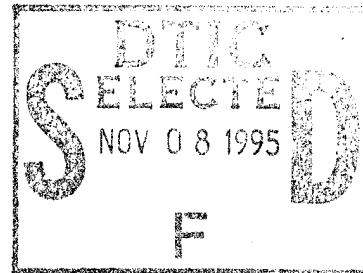

CONTRACT NAS1-17918
JULY 1987

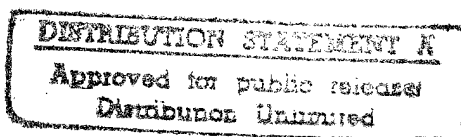

19951102 011

NASA

DTIC QUALITY INSPECTED 8

PLASTEC 5082B

NASA Contractor Report 4084

The Surface Properties of Carbon Fibers and Their Adhesion to Organic Polymers

W. D. Bascom
*Hercules Aerospace
Magna, Utah*

L. T. Drzal
*Michigan State University
East Lansing, Michigan*

Prepared for
Langley Research Center
under Contract NAS1-17918

Accession For	
NTIS	CRA&I <input checked="" type="checkbox"/>
DTIC	TAB <input type="checkbox"/>
Unannounced <input type="checkbox"/>	
Justification	
By DTIC-AT memo	
Distribution! 11-2-95	
Availability Codes	
Dist	Avail and/or Special
A-1	



National Aeronautics
and Space Administration

Scientific and Technical
Information Office

1987

Table of Contents

	Page
I Introduction	1
II State-of-Knowledge of Carbon Fiber Surfaces	4
A Carbon Fibers - Structure and Bulk Properties	4
B Carbon Fiber Surface Treatment and Sizing	20
C Surface Characterization Techniques	23
1 Microscopy	23
2 Surface Spectroscopies	26
3 Wetting Measurements	30
4 Direct Chemical Analysis	32
5 Other Techniques	33
D Carbon Fiber Surface Properties	34
1 Surface Morphology	34
2 Surface Chemistry	38
3 Surface Free Energy	41
III State-of-Knowledge of Carbon Fiber Adhesion to Polymers	43
A Adhesion vs Bond Strength	43
B Adhesive Interfacial Shear Strength	53
C Adhesive Tensile Strength	59
D Polymer Properties Near the Interface	60
E Interfacial Processing Conditions	65
F Fiber/Matrix Adhesion and Composite Mechanical Properties	68

	Page
IV Critical Issues	73
A Properties of Carbon Fiber Surfaces	74
B Properties of the Matrix	78
C Properties of the Interphase	79
V Conclusion and Recommendations	81
VI Appendix	83
VII References	86

I INTRODUCTION

The purpose of this report is to document the state of knowledge of the surface properties of carbon fiber (CF) and the properties of the interface between carbon fiber and polymers with emphasis on the fiber/matrix adhesion in carbon fiber reinforced plastics (CFRP). The report is an outgrowth of a conference held at NASA Langley Research Center on December 10-12, 1985 which had been called to review the problem of low bond strength between carbon fibers and certain thermoplastic polymers. The conferees included a small group of specialists in composite materials, surface chemistry, and composite mechanical behavior and were drawn from government, academe and industry (Appendix I).

It was evident at the close of this meeting that there is a serious lack of knowledge not only about CF adhesion to thermoplastics but on the nature of the CF surface itself and its interface with all classes of polymers. Consequently, this report draws not only on the discussion generated at the meeting at Langley but also on the available information in the open literature and from private discussions with people working on carbon fiber composites.

In the search for improved delamination resistance in continuous CF reinforced composites the importance of matrix fracture energy has become evident (1) and has prompted interest in using the inherently high fracture energy thermoplastics as matrix resins. However, it was discovered that

the tough thermoplastic polymers that had the other necessary requirements for a matrix in structural components (e.g., solvent resistance, high modulus, and high Tg) do not have the bond strength to carbon fibers equivalent to that of the thermosetting polymers such as the epoxies and polyesters.

The problem became especially evident in the NASA/Langley program on the micromechanics of delamination when a series of thermoplastic polymers were selected to model different modes of matrix failure. Scanning electron microscopy (SEM) of the fracture surfaces of composites revealed evidence of low fiber/matrix adhesion.

Table I-1 lists thermoplastic polymers known to exhibit poor adhesion to carbon fiber based on fractographic (SEM) examination indicating an absence of polymer on the fibers compared to a similar CF/epoxy matrix fracture surface. Also listed in Table I-1 are the critical aspect ratios (l_c/d) measured using a single fiber shear adhesion test described later (Section III-A). The critical aspect ratio is an inverse function of fiber resin adhesion for a given fiber strength (σ_f) and fiber diameter (d).

Table I-1

Thermoplastic Polymers Which Exhibit
Poor Adhesion to AS4 Carbon Fiber

<u>Polymer</u>	<u>Critical Aspect Ratio, l_c/d^{**}</u>
Polyetheretherketone*	—
Polyphenylene sulfide*	—
Polycarbonate	106
Polyphenylene oxide	125
Polyetherimide	93
Polysulfone	121
(typical epoxy)***	60

* Adhesion can be significantly improved by proprietary methods

** W. D. Bascom and L. W. Cordner, NASA Contract NAS1-17918

***Epon 828/m-PDA (reference 48)

In the discussion of this problem at the Langley meeting it became evident that there was insufficient information about the CF surface properties and CF/polymer adhesion to adequately explain the adhesion problems to thermoplastics. The key questions brought forth can be broadly grouped into;

- o chemical and morphological character of CF surfaces
- o physical and chemical nature of the CF/polymer interphase
- o factors that influence adhesion between CF and polymers
- o the effect of CF/matrix adhesion on laminate mechanical properties

The scope of this report is to review the state of knowledge in these key areas, identify specific questions, and suggest research areas that could significantly improve the understanding of these issues. A comprehensive discussion of all aspects of CF surface properties and adhesion is beyond the scope of this report but in many instances the reader is directed to specific references for detailed information.

II STATE-OF-KNOWLEDGE OF CARBON FIBER SURFACES

A. Carbon Fibers - Structure and Bulk Properties

The carbon fiber reinforcement used almost exclusively in structural applications today is made by the oxidation/carbonization of polyacrylonitrile (PAN) fiber. Consequently, the discussion here is restricted to PAN-based CF. The basic structure of PAN is;

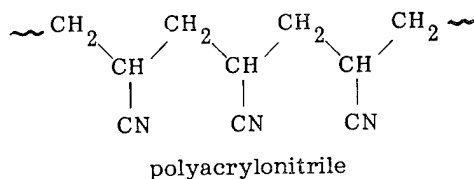

which is oxidized at temperatures of about 200°C to a ladder polymer structure according to the scheme shown in Figure II-1. The anion X is presumed to be present as an impurity in the PAN precursor. Subsequent heat treatment at temperatures up to 1000°C and higher results in a polyaromatic structure as shown in Figure II-2. These are highly idealized schematics but serve to illustrate that graphitic structures can form at least over limited spatial regions.

The resultant fiber is generally described as a columnar arrangement of misoriented turbostratic graphite crystallites. It is generally agreed that the degree of graphitization and crystalline organization is increased with increasing carbonization temperature. However, because of crystal misalignment and the presence of non-graphitized structure, these fibers are generally referred to as carbon rather than graphite fibers.

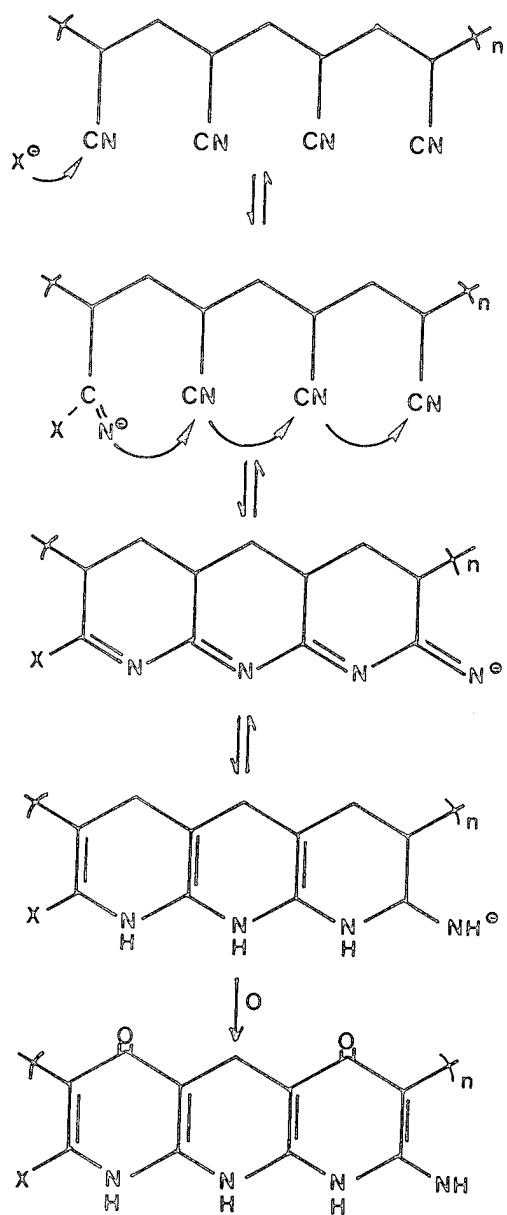

Figure II-1 Schematic of the oxidation of PAN precursor to a ladder polymer (2)

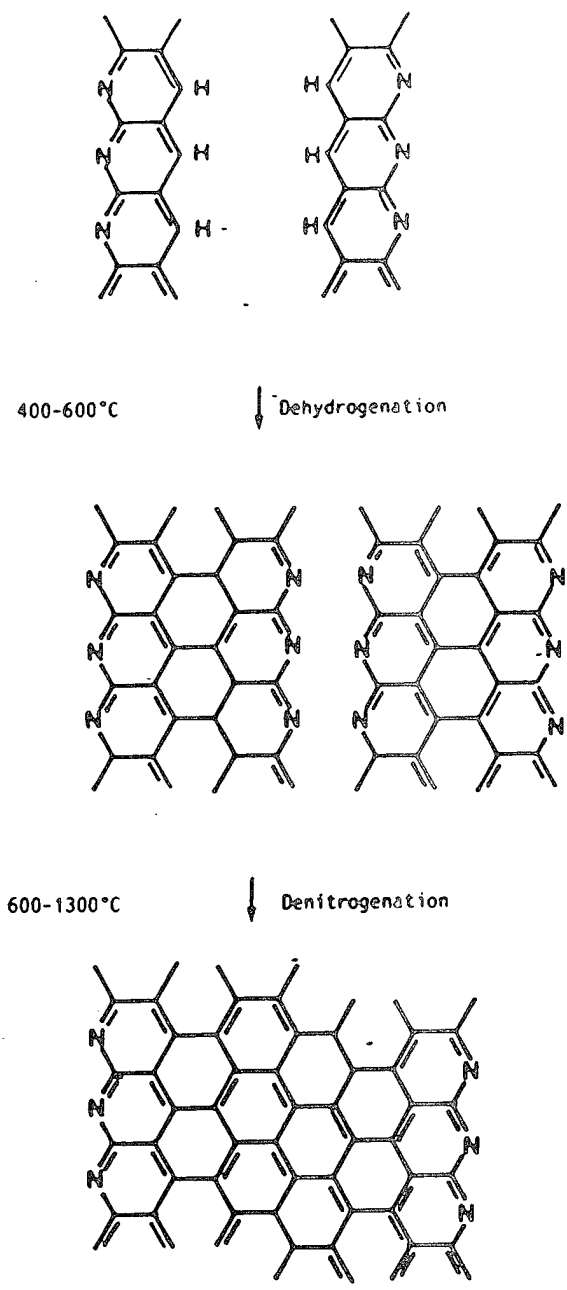

Figure II-2 Schematic of graphitization of oxidized PAN (3)

Various models of the internal structure of carbon fiber have been suggested based on high resolution microscopy, electron and X-ray diffraction, neutron scattering and other techniques. Current thinking favors localized fibrillar structures which are organized into wrinkled and distorted ribbons and sheets as shown in Figure II-3. One feature of the structure in Figure II-3 is the skin-core arrangement. The outer layers (skin) are more organized than the interior (core). The relative proportion of skin to core appears to be a function of the final carbonization temperature - high temperatures leading to thick skin structure⁽⁵⁾.

Crystallite dimensional parameters have been measured using X-ray diffraction, electron diffraction and neutron scattering. These parameters are the crystalline stacking thickness, L_c and the average layer width L_{ap} as shown in Figure II-4. These crystallite dimensions vary with the processing conditions as shown in Table II-1⁽⁷⁾. Note in Table II-1 the marked effect on crystallite size of applying stress to the fiber during processing.

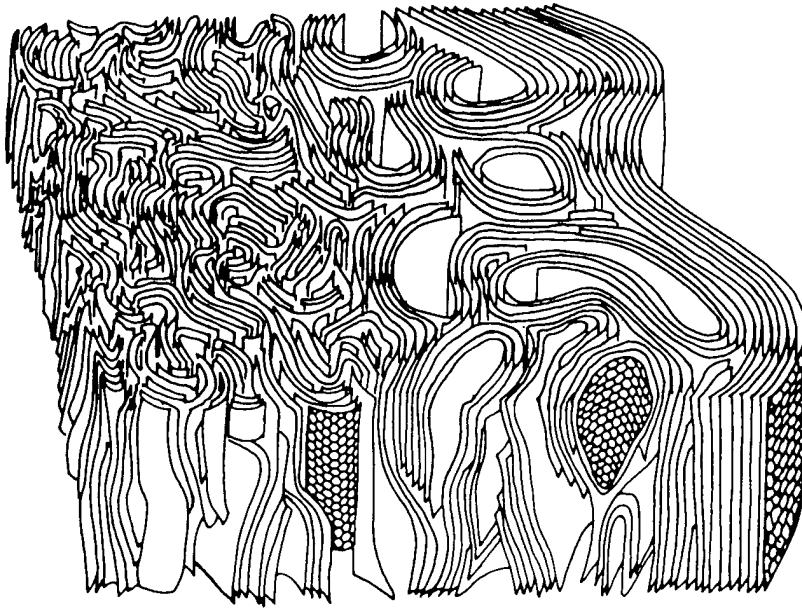

Figure II-3 Carbon fiber three-dimensional model (4)

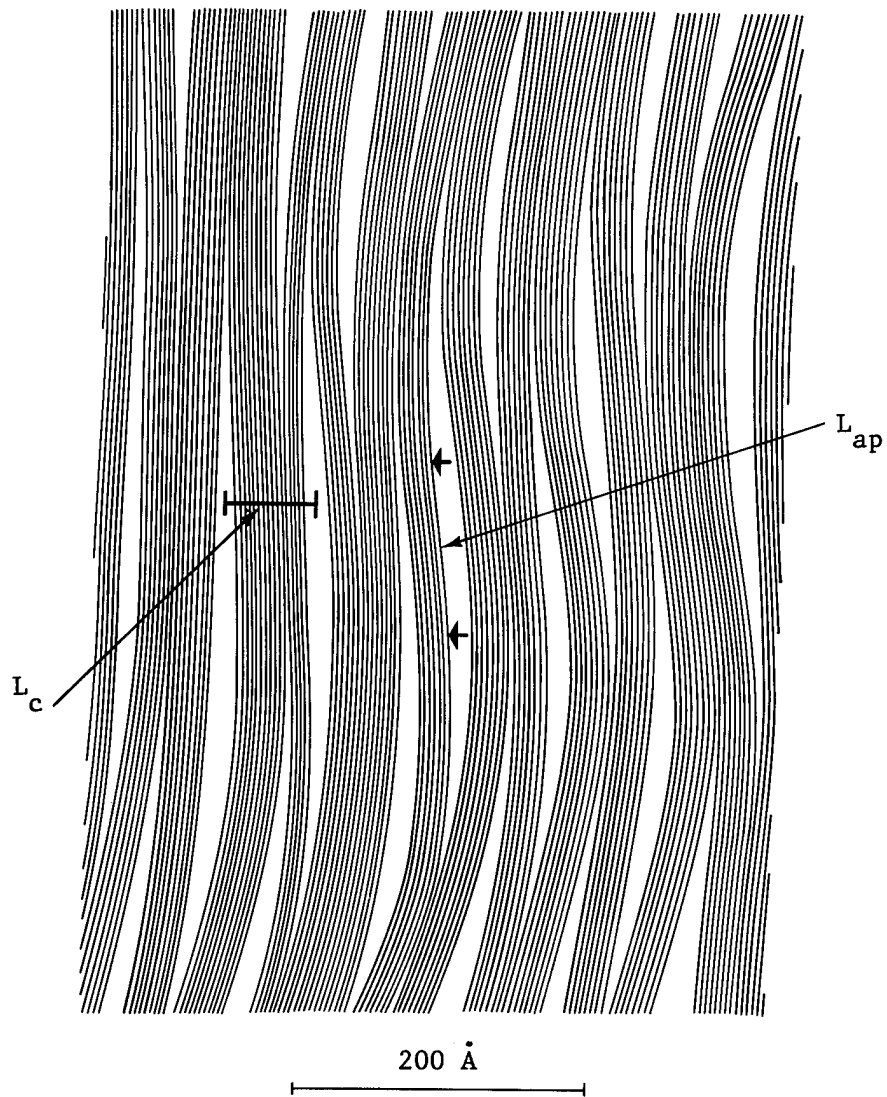

Figure II-4 Crystallite dimensional parameters (6)

Table II-1
 Crystallite Dimensions of PAN Carbon Fibers
 (Reference 7)

Heat Treatment Temperature (°C)	L_c (nm)	L_{ap} (nm)
1000	1.0	2.0
1400	1.8	3.5
2000	3.4	5.4
2400	4.0	6.21
2800	6.0	7.0
2250 ^a	20.0	50.0
2500 ^b	5.7	4.6

^aStress graphitized

^bControl

Until very recently PAN-based fibers have been classified into two categories; Type I (high modulus) and Type II (high strength). The range of properties of these fiber types are listed in Table II-2.

Table II-2

Carbon Fiber Classification

Type	Heat Treatment Temperature (°C)	Modulus GN/m ²	Tensile Strength GN/m ²	Long Range Order
I	>2000	310-517	1.68-1.45	high
II	~1500	145-276	2.35-3.10	low

Over the past few years fiber classification has become less clear cut due primarily to industrial demands for a "balance" of mechanical properties. Table II-3 lists some current fiber types used for structural applications.

The fiber classifications in Table II-3 clearly overlap which reflect a demand for a mix of properties and the fact that fiber development is in an evolutionary stage. Currently, the intermediate modulus IM fibers are in greatest demand since they offer high strength, stiffness, and elongation. However, the airframe and missile industries are looking to the carbon fiber manufacturers for even better performance; a 7.0 GN/M² (1000 ksi) strength fiber with 2% elongation and a modulus of 345 GN/m² (50 Msi) or higher. Fibers with these properties have been realized in the laboratory and it is only a matter of time before these laboratory processes are scaled up to production level.

Table II-3

Current State-of-the-Art Carbon Fibers

(Tow Test Data)

<u>Fiber Type</u>	<u>Modulus GN/m²</u>	<u>Tensile Strength GN/m²</u>	<u>Tensile Elongation (%)</u>	<u>Examples</u>
Ultra High Modulus	524	2.1	0.4	P75(a)
High Modulus (Type I)	350-360	2.5	0.7	HMS-4(b) G50(c)
Intermediate Modulus	280-310	4.8-5.5	1.8-1.95	IM-6(b) IM-7(b) HiTex 42(d) Toray 40(e)
High Elongation	240-260	4.5-4.8	1.90-2.0	AS-6(b) Toray 700(e)
Intermediate Strength (Type II)	235	4.1	1.5-1.7	AS-4(b) T300(a)

(a) Amoco Chemicals Corp.

(b) Hercules Inc.

(c) BASF Fibers

(d) Owens Corning Fiberglass Corp.

(e) Toray Industries Inc., Osaka, Japan

It should be emphasized that the mechanical property data depend very much on the way the fiber is tested. Basically there are three methods of determining the unidirectional 0° properties of CF; single fiber tensile tests, tow tests, and laminate tests. Single fiber tests are tedious, provide only strength data, and are seldom reported except as research results. In Figure II-5 single fiber data are presented as a Weibull distribution of tensile strengths. The data dispersion is typical of any

brittle fiber for which the strength is determined by adventitious flaws. Carbon fiber tensile strengths are more commonly reported as tow data or as 0° laminate data. Impregnated tows from 1000 to 12,000 filaments are pulled through a liquid epoxy and then a die to bring to a pre-determined fiber volume fraction, V_f . The resin is cured and then tested in 6-8in. lengths (ASTM D4018-81). Laminates are prepared by prepreg layup according to ASTM D3039 (prepreg \equiv sheets of fiber impregnated with uncured resin). Tow and laminate data are presented as Weibull plots in Figures II-6 and II-7. A comparison of 0° tensile properties is presented in Table II-4 (data from Figs. II-5, 6 and 7).

Table II-4
Effect of Test Method on Tensile Strength (σ_f)
of IM-6 Carbon Fiber

<u>Single Filament Test*</u>		<u>Tow Test (8)**</u>		<u>0° Laminate Test(8)**</u>	
GN/m ²		GN/m ²		GN/m ²	
σ_f	<u>SD</u>	σ_f	<u>SD</u>	σ_f	<u>SD</u>
4.24	1.15	5.35	0.28	4.84	0.19

*Warren Schimpf, Hercules Inc.

**data normalized to 100% V_f

SINGLE FILAMENT TENSILE TEST

(IM6/Unsize)

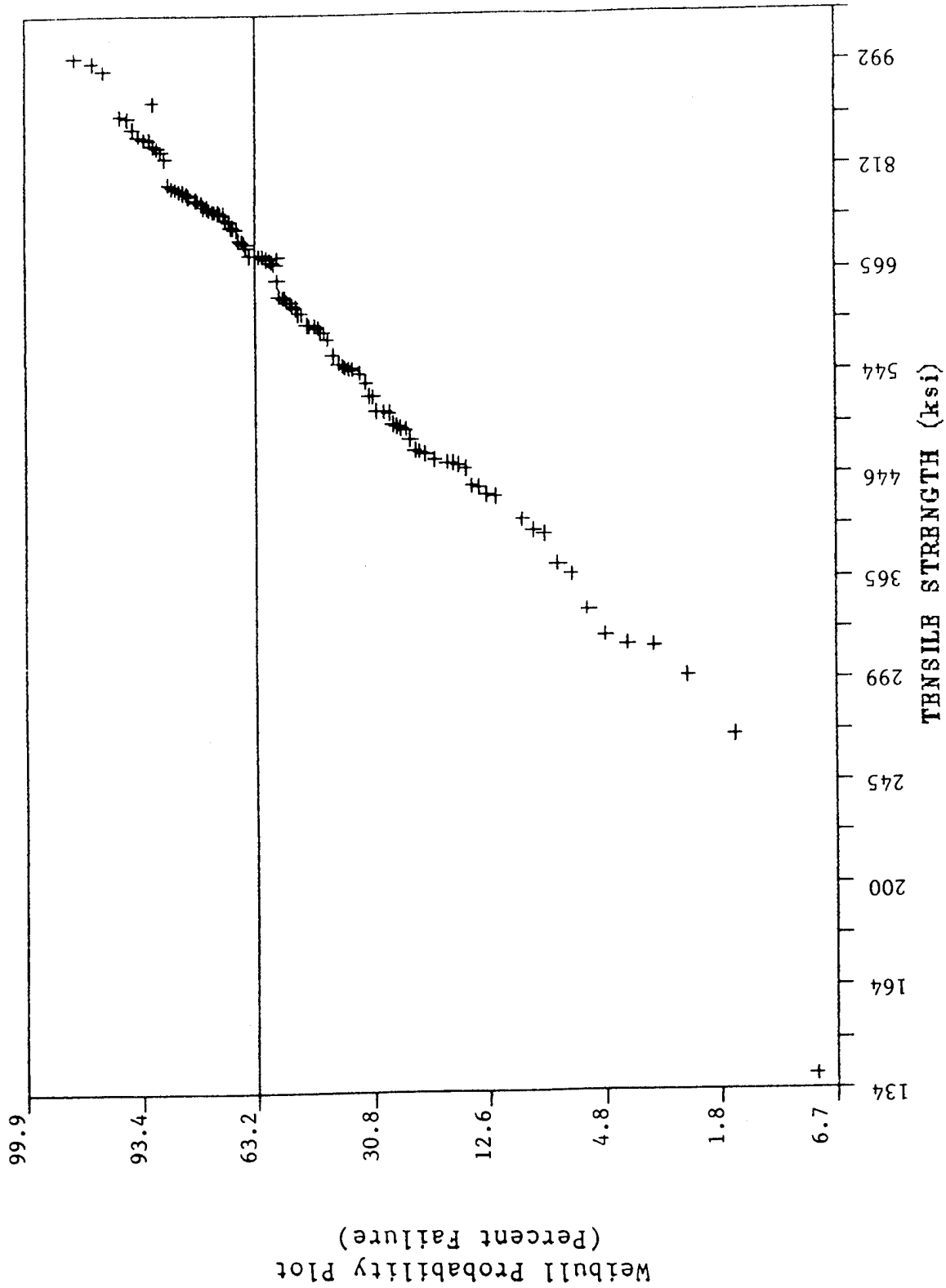

Figure II-5 Weibull plot of single filament tensile strength data for IM-6 carbon fiber (Dr. W. Schimpf, Hercules Research Center, Hercules Inc., Wilmington Del.)

Tow Test
(IM6/Unsize)

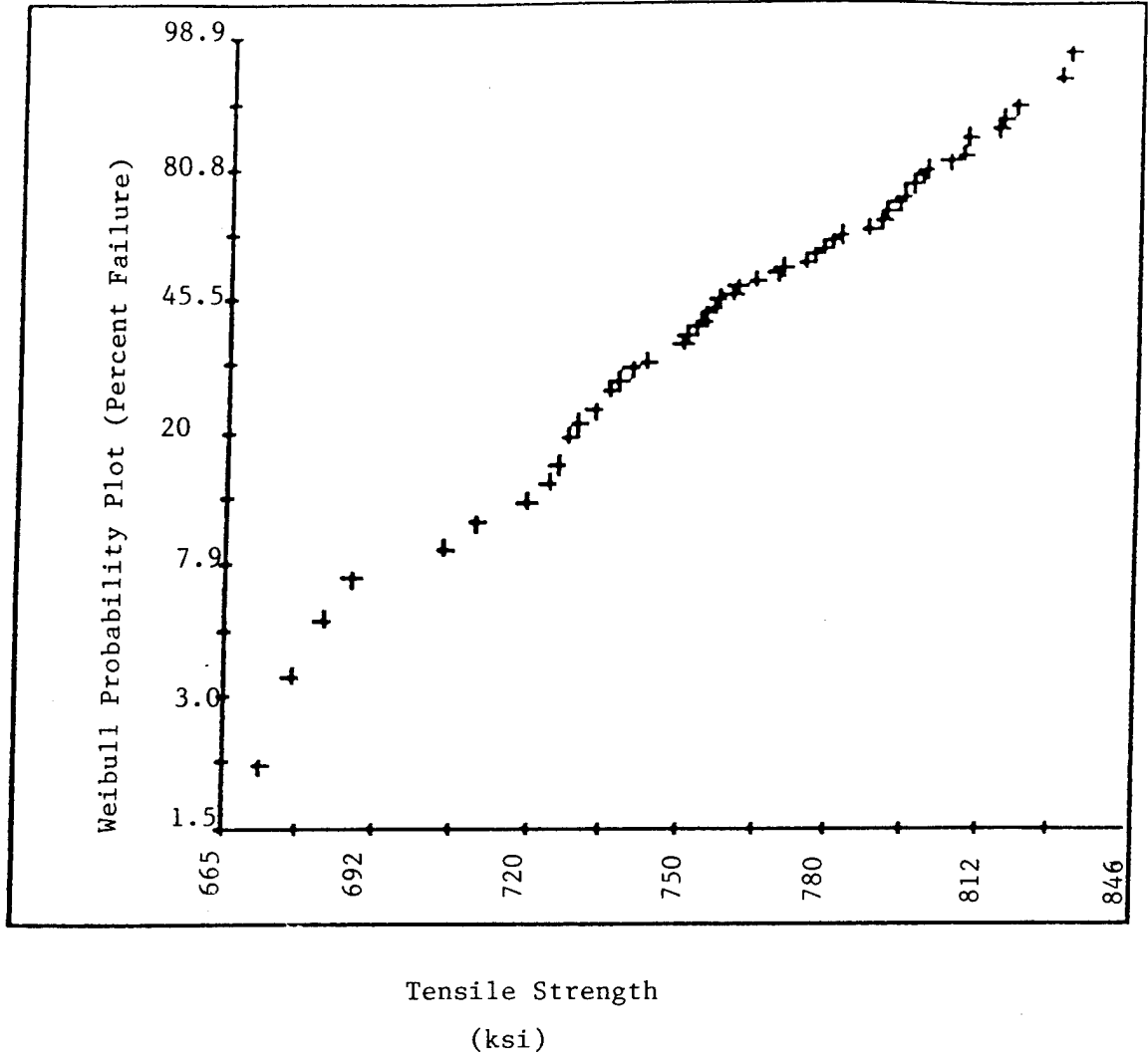

Figure II-6

Tow tensile strength data for IM-6 fibers in diglycidylether epoxy cured with an aromatic amine mixture. Fiber volume normalized to 100%

(Bascom, W. D. and Hummel, K.; Hercules Inc. unpublished data)

Laminate Tensile Strength
(IM6/Unsize)

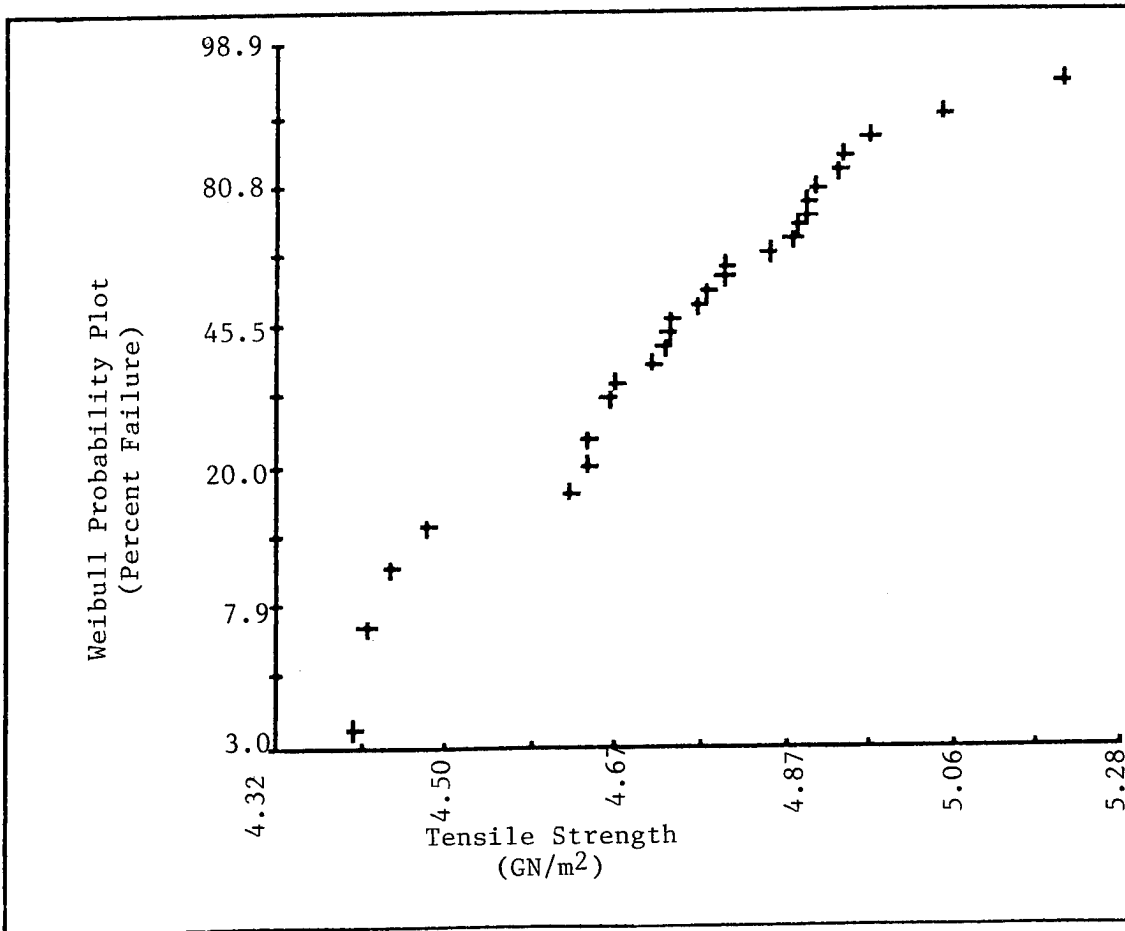

Figure II-7 Laminate (0°) tensile strength data for IM-6 fiber
in Hercules 2502 resin. Fiber volume normalized to
100%

(Bascom, W. D. and Hummel, K.; Hercules Inc. unpublished data)

Table II-5
 Effect of Matrix Resin Fracture Energy
 on 0° Laminate Tensile Properties *

<u>Property @ RI</u>	<u>Matrix Resin</u>				
	<u>3501-6</u>	<u>DR-1</u>	<u>DR-2</u>	<u>DR-3</u>	<u>DR-4</u>
0° Tensile Strength ** (GN/m ²)	4.21	4.29	5.00	4.98	4.92
0° Tensile Modulus ** (GN/m ²)	241	238	285	271	246
0° Tensile Elongation (%)	1.55	1.79	1.79	1.81	1.94
Resin Fracture Energy (J/m ²)	74	507	734	787	1102

* Greever, W. L. and Bascom, W. D.; Hercules Inc., unpublished data

**Normalized to 100% Fiber Volume

The results in Table II-4 clearly indicate the effect of test method on 0° mechanical properties. Single fiber tests provide essential information about the fiber itself - the nature of the flaw types and distribution. However, results from tow and laminate testing are composite data and are more pertinent to end-use purposes; tow data is sought as a measure of hoop strength by the missile community whereas laminate data is used by the airframe industry where structures are most often fabricated by prepreg layup.

In evaluating tensile properties, it is obvious that in order to make rational comparisons the test method must be specified. Another consideration is that tow and laminate data are usually normalized to some constant fiber volume (V_f), 65% or 100%, which can further confuse comparisons. In Table II-3 all the data are from tow testing and are normalized to 100% V_f . Moreover, the choice of matrix resin also appears to affect tensile strength. In Table II-5 data are presented for the tensile strengths and elongation of fibers from a single production lot tested in resins that were formulated to have increasing fracture energies by a systematic increase in the amount of a homogenous plasticizer. This sampling of data suggests that the fiber exhibits increasing strength and elongation with increasing resin toughness. The situation is not as simple as Table II-5 might suggest in that other resin properties can influence the test results. Nonetheless it is clear that fiber tensile testing is by no means independent of the resin matrix or test method.

The advances that have been made in CF properties, especially over the last five years, are the result of the following factors;

- changes in the chemistry of the PAN precursor
- improvement in the quality of the PAN precursor especially with regard to defects
- introduction of fiber stretch at various stages of fiber production
- improved surface treatment methods
- continuous vs batch fiber production (less post-manufacture damage)
- improved fiber sizings

B. Fiber Surface Treatment and Sizing

It has been realized since the first development work on carbon fiber that laminate properties, especially under shear loading, could be dramatically improved by an oxidative surface treatment. There is a large body of literature on the effect of these treatments on the surface properties of the fiber and on laminate strength. This subject is discussed in more detail in later sections of this report. It is generally thought that the surface treatment "activates" the surface to improve

adhesion to matrix polymers primarily by introducing oxygen functionality for interfacial reactions. This is probably a simplistic picture. The most commonly used surface treatments are air oxidation and electrolysis which lend themselves to continuous production but the details of these industrial processes are proprietary.

Sizing of carbon fiber involves application of an organic film (usually polymeric) to protect the fiber during fabrication into structures. The amount of sizing varies between 0.5-1.5 wt % of the fiber depending on the fiber type and its intended purpose. Occasionally, surface treatment and sizing are confused and thought to be synonymous; clearly they are not. Sizings are applied to hold fiber bundles (tows) together and provide some protection during processing. Filament winding of CF is especially aggressive in that the tows are held under tension as they pass through eyelets and over guides. Sizings for filament winding tend to encapsulate the tow and hold it as a relatively cohesive bundle. At the same time, the sizing must be sufficiently friable to allow the tow to be opened up and readily impregnated by the liquid resin. Similar requirements are necessary for the weaving of carbon fiber tows and often the same sizing is used for both weaving and filament winding. In prepregging operations, the tows are collimated and brought into contact with pre-filmed resin, often between nip rolls. This is a less aggressive process than filament winding or weaving so that prepreg sizings leave the fiber tow less encapsulated and more flexible. The role of sizing for prepreg is primarily to hold down loose fiber ends which otherwise become misaligned in the prepreg

sheet or break loose and gather into small bundles often referred to as "comets." It is problematical whether a small number of misaligned fibers or comets have any significant effect on laminate mechanical properties. Nonetheless, they detract from the cosmetic appearances of the prepreg and they may interfere with high rate production equipment such as automatic tape laying machines that are rapidly being introduced into the airframe industry.

There is no clear cut evidence that the commercial sizings currently applied to carbon fiber for epoxy/matrix composites significantly improve laminate mechanical properties. In fact, in developing sizings for improved processing one of the criteria is that the sizing agent not have a seriously adverse affect on laminate properties. In a recent study* a comparison was made of the laminate properties using unsized CF with laminates prepared using five different epoxy-compatible sizings. It was found that the sizings had no affect on laminate properties compared to the unsized fiber. In this study the data sampling was large enough to show that any apparent effects of sizing were within the normal data scatter and not statistically significant. However, there have been reports where the sizing does have an effect on laminate properties⁽⁸⁾. Indeed, in a later section (III-D) evidence is presented that resin coatings on CF can significantly affect fiber-matrix adhesion. However, sizing agents presently in commercial use are designed for processing and not tailored to enhance laminate properties.

*Bascom, W. D. and Hummel, K.; Hercules Inc. unpublished data

C. Surface Characterization Techniques

The interaction of a carbon fiber surface with a polymeric material depends on the topographical features of the fiber surface as well as its atomic and molecular composition. Topographical features can range in size from less than ten to over a thousand nanometers. The chemical composition of the fiber surface can consist of weakly adsorbed material which can be removed by the application of thermal energy as well as strongly adsorbed material which is chemically attached to the fiber surface with strong covalent bonds. Both types of material are capable of affecting the fiber-matrix interaction and therefore both must be completely characterized. A wide variety of microscopic, spectroscopic and thermodynamic techniques are available which are suitable for this type of characterization. It should be pointed out that there is no single surface analysis technique which by itself can give the combination of physical, chemical, thermodynamic and topographical information required to provide a firm basis for understanding the polymer-carbon fiber interface. However, selective use of a combination of these techniques can provide a complete picture.

1. Microscopy The most fundamental surface characterization technique is microscopy. Optical, scanning electron microscopy (SEM) and transmitted electron microscopy (TEM) offer a set of complementary experimental techniques which provide valuable topographic information from the macroscopic down to the atomic level.

Optical microscopy is used to provide basic information about the fiber and its geometrical characteristics. For the ten μm or less diameter carbon fibers, optical microscopy can provide information about the fiber diameter and cross-section and variation in diameter with length. The upper limit of resolution of the optical microscope is about one-tenth of a micron so features less than a micron can not be well characterized.

Scanning Electron Microscopy uses electrons as the probing medium and therefore has a much higher limit of resolution. Primary and secondary electrons can be collected after interaction with the carbon fiber and used to reconstruct the image of the surface. The large depth of field associated with the SEM observations make the surface images very informative. Features of the fiber surface down to the 5 nanometer level can be observed. An additional advantage associated with the large depth of field is the ability to observe three dimensional features on a surface. Sample stages manipulatable in three dimensions provide complete access to any feature of the fiber topography.

Scanning electron microscopy of CF is limited for most instruments by "charging" of the surface. Electron build-up on the relatively low conductivity fiber can seriously obscure surface details. This problem is overcome by the electrodeposition of conductive metal coatings (e.g., Au) to the surface. However, as useful as the coatings may be, they are 10-20 nm thick and may obscure small scale surface features.

The Transmission Electron Microscope provides the highest resolution of any of the microscopic techniques routinely available. The attainment of this capability requires that the electron be transmitted through the sample. The depth of penetration of an electron into a solid is limited by the accelerating voltage. This limits the technique to either samples less than one hundred nanometers in thickness or to replicas of the surfaces of interest.

Replication of surfaces for TEM has been used for decades. A composite replica made from a thin polymer and surface coating is formed on the fiber surface by deposition techniques and then removed intact for direct observation in the TEM. Limitations of this approach are in the ability to remove the replica intact and the generation of surface artifacts through the replication process itself.

Direct TEM observation of the fiber surface can be achieved through the use of ultramicrotomy. Ultrathin samples, typically about 50 nanometers in thickness, are cut from the sample. This involves encapsulating the carbon fiber in a resin to immobilize it during the cutting process. A diamond knife is passed through the sample and consecutive slices of material are made, floated on the surface of a fluid and collected on an electron microscope grid for direct TEM observation. This technique is very useful for fiber-matrix interfacial characterization by observing a through thickness section that includes the fiber surface and adjacent regions.

Fracture events occurring before sample microtoming can be preserved for later analysis and the locus of interfacial failure can be detected by this technique. Like any experimental technique however, artifacts are produced in the cutting process which must be characterized and separated before interpreting the results.

2. Surface Spectroscopies Fundamental information about the atomic and molecular composition of the fiber surface can be obtained through the use of suitable surface spectroscopies. These analyses operate by bombarding the surface of interest with a probe atom, ion, electron or photon. These species either interact with the surface and are energy analyzed or cause the emission of surface species which are characteristic of the surface environment. Each spectroscopic technique has its own advantages and limitations when applied to carbon fibers.

Auger Electron Spectroscopy (AES) probes the surface with high energy electrons. These electrons interact with atoms at and below the surface causing the emission of Auger electrons. The energy of these electrons is such as to restrict their emission to those in the first thirty or forty atomic layers of the material. The energy of the Auger electrons is measured and uniquely relatable to the host atom from which the electron came. Quantitation of the surface atomic composition and concentration can be obtained and in some instances molecular information is possible from analysis of the data⁽⁹⁾.

As with any electron bombardment technique, electron induced surface heating, desorption, etc. is possible coincident with the analysis. This is much less likely in a conducting material or in a material that is stable to high temperatures. While beam effects on carbon atoms in the fiber are a remote possibility, desorption of physisorbed and chemisorbed material is very likely rendering the analysis susceptible to changing composition during the experiment. New advances which use a very narrow focused beam which is scanned across the surface reduce the dangers of surface change during analysis. Most of the published data on surface analysis of carbon fibers using AES has been collected with older model instruments without the scanning capability and has been limited to identification of atomic composition and concentration. Many of the experimental limitations associated with sample heating, electron induced desorption, etc. can be eliminated through the use of X-ray Photoelectron Spectroscopy (XPS) also known as Electron Spectroscopy for Chemical Analysis (ESCA). X-ray photons are used as the probing species rather than electrons as in AES. These photons cause the ejection of core electrons from atoms in the material under investigation. Because of the short mean free path for these core electrons, only electrons from the first few atomic layers are able to escape from the surface to the collector. This makes the analysis a surface sensitive technique. Since there are unique binding energies associated with the molecular environment of each core electron, in principle it is possible to determine the molecular environment each electron came from. Counting techniques are quantitative and surface concentrations can be accurately and reproducibly determined⁽¹⁰⁾.

Photon induced desorption of surface species are much less likely than electron induced effects, consequently surface changes induced during the course of the analysis are less likely with XPS. Sample heating is also reduced because of the lower power coupled to the surface.

Certain limitations do exist however. The absolute value of the binding energies determined for each photoelectron are not unique. The spread of binding energies for all carbon oxygen species for example covers only 3 eV. In practice, model studies have been used to quantitatively determine the molecular structure⁽¹¹⁾. Likewise, the photoelectrons collected can arise from the surface layer as well as from up to ten atomic layers below the surface. Sample charging can be a problem for a semiconductor such as carbon fiber. This can be mitigated by the use of a flood gun to keep the surface potential of the fibers constant. These factors must be considered when the data is reduced. For carbon fibers, relative comparisons are straightforward and a finite number of surface species and molecular states exist for the atoms typically found on the fiber surfaces.

Ion Scattering Spectroscopy (ISS) is the third major surface analysis technique. The molecular probe in this case is an ion which is directed at the surface, loses energy during the collision, and is collected and the energy analyzed. ISS is truly a surface sensitive technique in that only

the atomic environment of the outermost surface with which the ion collides determines the scattering behavior. The limitations of the technique are that only atomic information can be obtained, the sensitivity for each element varies across the periodic chart, and the collision process itself causes some desorption of surface species. Most applications to carbon fibers have been used to identify elements in the outermost surface layer⁽¹²⁾.

Positive and Negative Secondary Ion Mass Spectroscopy (+ or - SIMS) makes use of the sputtering process to cause removal of the surface atomic layer in a controlled manner using accelerated ions in the same manner as with the ISS analysis. In this case the sputtered species are collected in a mass spectrometer which has been biased either positively or negatively. Cracking patterns having unique molecular characteristics result from the destruction of parent molecules in a manner identical to that found in a mass spectrometer. Simultaneous solution of these spectra using known cracking patterns gives quantitative information about the identification of parent surface molecules and their concentration. The species detected are only from the surface layer. The major limitations are that the cracking patterns of the parent molecules must be known for the conditions of the experiment and that techniques like ISS or SIMS are destructive in that the surface layer is being removed during the analysis.

Other surface techniques exist for the identification of surface composition. The most notable is fourier transform infra-red

spectroscopy. Applications of this molecular spectroscopy have limited use for carbon fibers because of the adsorption of the interrogating radiation by the fiber and because of the small surface to volume signal for the fibers themselves. Advances are occurring which have the promise for increasing the sensitivity of the technique so that molecular information about the surface composition can be achieved.

3. Wetting Measurements A necessary criterion for achieving a stable fiber-polymer interface is that the surface free energy must decrease when the interface is formed. Surface free energies of solids cannot be calculated for real surfaces and cannot be measured directly. Indirect measurements are possible however.

The contact angle which a drop of liquid forms when placed in contact with a surface represents the equilibrium state between the liquid and the substrate and can be used as an indication of compatibility. If the contact angle θ formed is less than 90° then the surface is said to be 'wet' by the liquid. If the contact angle is zero the liquid is said to 'spread' on the substrate. Spreading is more desirable than wetting alone although each insures an acceptable interfacial free energy for adhesion in that the thermodynamic work of adhesion (W_A) is positive (see Section III-A).

The measurement of contact angles on cylindrical fibers of less than ten microns in diameter presents some formidable experimental problems if

done optically. A variation of the technique is possible by immersing the fiber into the liquid of interest and measuring the force of immersion or emersion. A simple force balance allows the contact angle to be calculated if the fiber perimeter and surface free energy of the liquid are known. The fiber perimeter can be calculated directly using a liquid with a known low surface free energy which spreads on the fiber surface and does not form a finite contact angle. The apparatus usually employed for these tests is the Wilhelmy balance described in standard surface chemistry texts (13,14).

Additional information characteristic of the fiber surface and fiber-matrix interface is possible using this technique. If a series of liquids of similar structure and increasing surface free energy is used to measure the contact angle, a plot of the cosine of the contact angle versus liquid surface free energy will result in a straight line which can be extrapolated to $\cos \theta = 1$ or zero contact angle. This point is defined as the Zisman critical surface tension of the solid or the value of the surface tension below which liquids will "spread" and above which they will "wet" (15).

If contact angles are measured using liquids with different polar and dispersive character and the assumption made that the polar and dispersive components of the surface free energy are additive then the polar and dispersive components of the surface free energy of the solid can be

obtained⁽¹⁶⁾. The assumptions which are the basis for this determination are the subject of continuing debate. A refinement to this process exists by the declaration that the nondispersive forces can be characterized as being the sum of acid and base interactions. The measurement of contact angles coupled with the measurements of the heats of adsorption of probe liquids can provide a measure of the acid/base character of a solid surface⁽¹⁷⁾.

The surface free energies of liquid polymers can be measured directly using a variety of techniques either based on the same immersion technique used for contact angles on fibers or through determination of the shape of a molten drop of polymer either hanging or resting on a surface^{*}. From the surface free energy of the polymer one can predict interfacial compatibility and thermodynamic equilibrium with a substrate.

4. Direct Chemical Analysis A large body of literature exists on the chemical analysis of surface groups on carbon fibers. These techniques include acid-base titrations, specific chemical reactions such as diazomethane to detect hydroxyl groups, and the use of radiotracer labeled reactants. Ehrburger and Donnet⁽¹⁸⁾ found a strong correlation between weak acid groups (detected by sodium ethanolate) on treated fiber and composite interlaminar shear strength in epoxy matrix. The subject has been reviewed by Donnet and Bansal⁽¹⁹⁾, but has been largely superseded by spectroscopic techniques. An interesting combination of "wet chemistry" and spectroscopy is the labeling of surface groups with heavy metal ions

*see reference 14; pages 12 and 25

which are then analyzed by XPS or some other appropriate spectroscopy⁽²⁰⁾. However, as with chemical titration, there can be uncertainties as to the chemical specificity of the labeling ion.

5. Other Techniques Other methods of characterizing the molecular surface environment of carbon fibers exist. The chemical reactivity of the fiber surface can be determined by oxygen chemisorption measurements. A fiber sample is heated in a high vacuum to temperatures at which surface species are all removed. Careful introduction of oxygen into the sample chamber and monitoring the amount chemisorbed either directly through weight changes or indirectly through volumetric changes will allow quantification of the chemisorption sites. Variation of the thermal conditions associated with the chemisorption can be used to differentiate site reactivities.

The desorption process itself provides much information about the atomic and molecular character of the fiber surface. If a sample of carbon fiber is confined to a vacuum chamber on which a mass spectrometer is attached, identification of surface molecular species that desorb as a function of temperature can be made^(11,12). Weakly physisorbed material is removed from the fiber surface at temperatures up to 150°C. This material is always present on every fiber surface and if not removed properly can create interfacial voids during composite processing⁽²¹⁾. At higher temperatures, surface chemical groups are desorbed. The type and quantity of material volatilized at high temperatures provides information on the chemical structure of the surface.

Measurements of specific heats of adsorption between probe molecules and the fiber sites can be made either indirectly or directly. Adsorption studies using gaseous molecules having functional groups can be conducted. Distinction between physisorption and chemisorption can be made by checking for reversibility of adsorption. Replicate isotherms determined at various temperatures can be used to measure the heats of adsorption. An added benefit of this measurement is the determination of the fiber surface area through adsorption of inert gas molecules^(11,12). Topographical changes caused by surface treatments such as the creation of pores, cracks and fissures can readily be detected.

Direct measurement of the heats of adsorption of model probe molecules having the same functional groups as the polymer under investigation can be conducted using calorimetry. Flow microcalorimetry can be conducted in which small amounts of carbon fiber are confined to a sample chamber and the heats of adsorption of various probe molecules can be determined directly.

D. Carbon Fiber Surface Properties

1. Carbon Fiber Surface Morphology The surface properties of carbon fibers are intimately tied to the internal structure of the fiber itself. The basic building block of the fibers are the graphitic crystallites which are formed during the conversion of the PAN based precursor to the carbon

fiber⁽²²⁾. This crystallite is in turn composed of layers of graphite basal planes which are arranged turbostratically into a layered structure. The size of these crystallites is governed by the time and temperature conditions seen by the fiber as it is converted from PAN to carbon during the heat treatment step of its manufacture⁽²³⁾. Longer residence times coupled with higher graphitization temperatures in an inert environment promote larger planar graphitic basal planes and larger layered crystallites.

The crystallites themselves are arranged in a filamentary or ribbon-like morphology roughly parallel to the fiber axis. Strain applied during the processing steps and high temperature cause the axial alignment of these fibrillar entities to become more perfect and parallel to the fiber axis (Table II-1).

The result of these mechanisms is that the high modulus fibers tend to have surfaces that are predominantly composed of graphitic basal planes. In the lower modulus fibers, produced at relatively low graphitization temperatures, the orientation of the crystallites is altered to produce a surface with less graphitic basal planes. The edges and corners of these crystallites intersect the fiber surface in a greater percentage in the lower modulus fibers.

This mechanistic model presents an ideal picture of the bulk and surface structure of the carbon fiber after graphitization. The real

composition of the fiber surface is determined by the cataclysmic events which occur during the graphitization of the fiber. The decomposition of the polyacrylonitrile polymer backbone and subsequent rearrangement of the carbon atoms into the hexagonal graphitic structure involves the generation and removal of volatile material from the interior as well as the surface of the fiber. Graphitization most probably occurs from the surface inward. The escaping volatiles must continuously be transported through this forming surface leaving behind a very disrupted structure. The skin-core structure observed for some carbon fibers (Section II-A) clearly involves two opposing processes, consolidation of the outer layers and the simultaneous disruption of these layers as volatiles escape from the interior. Consequently, an as-formed carbon fiber without any treatment whatsoever would be expected to have a very defect laden outer surface.

Published structural studies confirm this picture. It has even been shown that a surface layer exists on the fiber surface which appears to be quite different morphologically than the bulk of the fiber⁽²⁴⁾. Adsorption tools have been used to probe the fiber surface to detect cracks, pores and fissures induced by fiber surface treatments. Prolonged oxidative treatments do produce a large array of cracks, pores and fissures which dramatically increase the fiber surface area⁽²⁰⁾. There is an accompanying loss in fiber mechanical properties with these treatments which indicates that the flaws generated are exceeding a critical size. However, the commercial treatments evidently operate without creating critical flaws since fiber tensile strengths are not reduced after commercial surface treatments, Figure II-8⁽²⁵⁾.

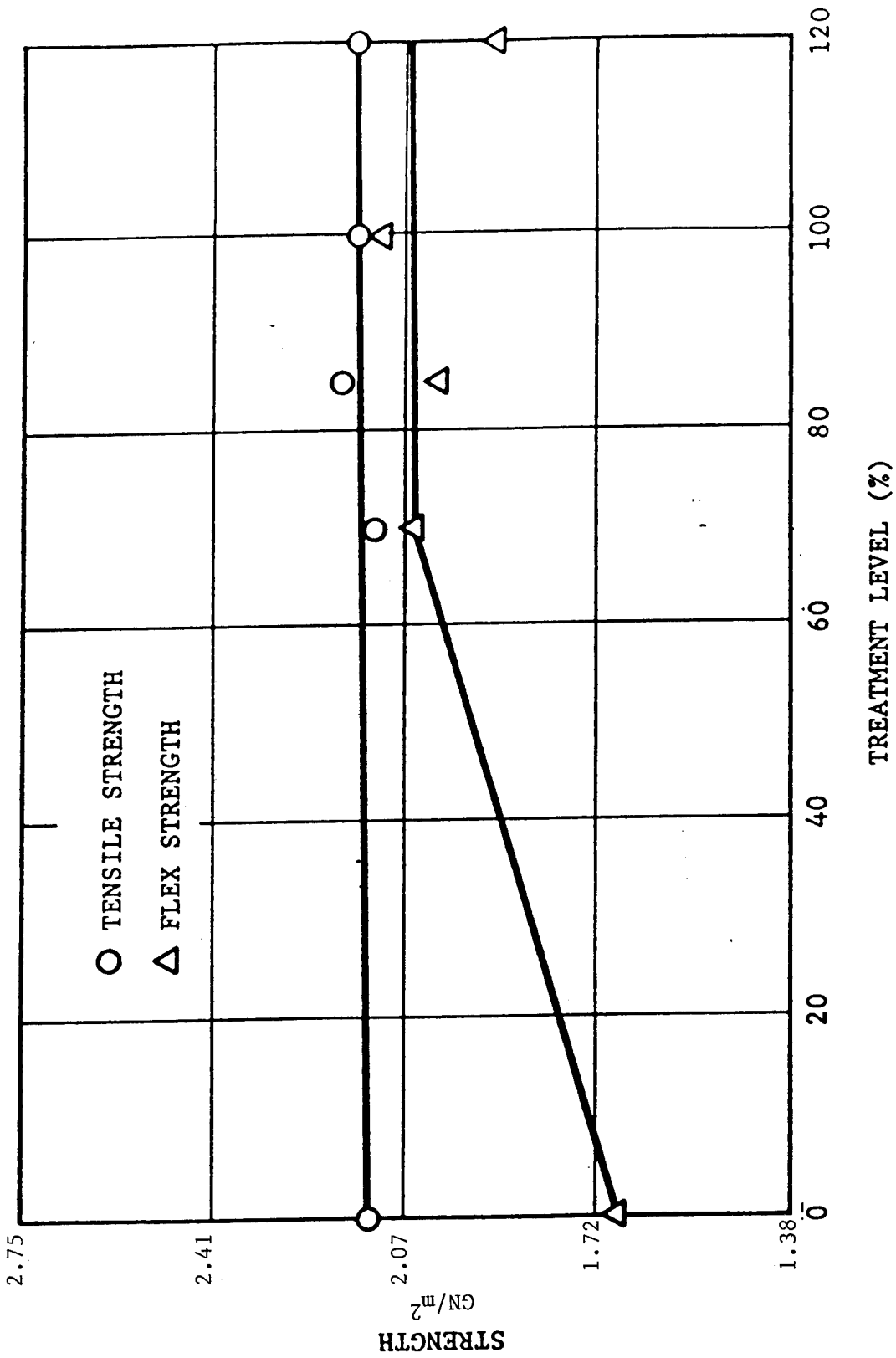

Figure II-8 Effect of surface treatment on 0° laminate tensile strength (O) and flexural strength (Δ)

The presence of basal planes on the fiber surfaces has implications for the surface chemical nature of the fiber surface. It has been shown that the graphitic basal plane is very inert to chemical attack. The sites for chemical attack of graphite are the edges and corners of the graphitic crystallites and not the basal plane surface⁽²⁶⁾. Because of the increase in basal plane orientation with increasing graphitization temperature and therefore modulus, less potential sites for the addition of chemical functionality exist on the higher modulus fibers than on the lower modulus material.

2. Carbon Fiber Surface Chemistry The main atomic constituent of the carbon fiber surface is carbon. Early work using wet chemical means of assessing the functionality of the carbon fiber surfaces assumed that the only other surface constituent was oxygen. Results obtained with carbon black which has a surface area of 100-200 times that of the carbon fiber, led to the opinion that oxygen was present on the fiber surface only in four forms. Carbonyl, phenolic, ether or lactone structures were postulated based on titration measurements⁽²⁷⁾.

Within the last decade, the application of surface spectroscopic tools to the determination of the surface composition of the carbon fiber has presented a different picture of the atomic and molecular composition. Auger and XPS measurements have shown that in addition to carbon and oxygen, other elements including nitrogen, sulphur, silicon and trace metals can be present on the fiber surface^(28,29). Their presence decreases

with increasing graphitization temperature. The source of these other atomic constituents is both from within the fiber itself and the oven environment.

The results in Table II-6 quantify the molecular environment of the surface atomic species. The total oxygen content is seen to be between 10 and 20% of the fiber surface with nitrogen from 4 to 6%^(29,30). At least three different oxygen states have been detected and have been assigned to the phenolic, carbonyl and ether structures⁽³¹⁾. The nitrogen has been assigned an amine like state. Other species are in a very low concentration (~ 1%) which makes quantification of their molecular state very difficult.

Table II-6

XPS Analysis of Carbon Fiber Surfaces

<u>Fiber*</u>	<u>C</u>	<u>O</u>	<u>N</u>	<u>Si</u>	<u>S</u>	<u>Na</u>	<u>Reference</u>
AU1	86	9	2	—	—	3	(32)
AS1	70	20	7	—	—	4	(32)
HMU	95	5	—	—	—	—	(32)
HMS	89	9	—	—	—	—	(32)
AU4	79	14	2	5	—	—	(61)
AS4	80	15	6				(61)
T300	96	2	3	—	—	—	(61)
C 6000**	81	14	4	—	—	1.0	(61)
T500	82	16	3	—	—	—	(61)
AS1	84	11	4	—	0.2	1.0	(33)
AS4	83	12	4	—	0.2	0.7	(33)
AS6	85	9	4	—	0.4	1.7	(33)
IM6	87	9	3	—	0.3	0.6	(33)

* see Table II-3 for fiber type (U-designation indicates no surface treatment)

**BASF Fibers, Type II

Significant physisorbed material is present on the fiber surfaces also. Volatile species such as water, carbon monoxide and carbon dioxide have been detected desorbing from the fiber surface with mass spectroscopy at temperatures up to 150°C. At temperatures above this point desorption of chemisorbed species begins to occur⁽¹²⁾. A constant evolution of material continues until temperatures around 750°C are reached before the removal of surface species is complete⁽³²⁾. Thus thermal desorption at elevated temperatures (>200°C) may provide information about surface structure especially if the desorbed material is analyzed by gas chromatography/mass spectroscopy techniques. However, it is quite possible that some of the evolved material comes from within the fiber.

3. Surface Free Energy The result of the combination of morphological features and surface chemical composition is the interaction of the carbon fiber surface with the environment. Thermodynamic analysis of the fiber surface free energy provides an ideal macroscopic method of characterizing the fiber surface in equilibrium with air.

The determination of the carbon fiber surface free energy is not directly possible for solid surfaces. An indirect approach is possible however from wettability (contact angle) measurements using homologous series of liquids⁽¹⁵⁾, with different liquids chosen for their polar or dispersive character⁽¹⁶⁾, or with liquids which vary in their acid and

base characteristics⁽¹⁷⁾. These measurements yield the total surface free energy and, in some cases, the surface free energy in terms of polar/dispersive and acid/base components.

For the low modulus carbon fibers, the surface free energies have been determined to be up to 50 mJ/m^2 (erg/cm^2). As the graphitization temperature increases, the presence of surface chemical groups diminishes and the percentage of the inert graphitic basal plane increases causing the higher modulus carbon fiber surfaces to be lower in surface free energy (about 40 mJ/m^2). Most polymers have surface free energies of 40 ergs per square centimeter or less and therefore the thermodynamic criterion for wetting of the fiber surface is met (see Section III-A). This implies that intimate contact between fiber and matrix has occurred. In some highly viscous materials, the constraints of processing at short times and low temperatures may not allow the required equilibrium to take place resulting in a nonequilibrium interfacial condition.

Polar/dispersive energy analysis of wettability data separates the surface free energy into dispersive and polar components which are sensitive to surface treatment conditions⁽³⁰⁾. The polar character of the fiber surface decreases with increasing modulus. For the intermediate modulus fibers (i.e. 315 GN/m^2) the polar component is only 20% of the total free energy. This is related to the lower population of edges and corners of the graphitic basal planes present on these fibers which have undergone the high temperature graphitization with the resultant growth in crystallite size and more uniform alignment. The lower modulus fibers have

a higher polar component of the surface free energy that can amount to about 50% of the total value. Kaelble has shown that matching of the ratio of the polar/dispersive character may be important to optimizing the interface⁽³³⁾.

III STATE OF KNOWLEDGE OF CARBON FIBER ADHESION TO POLYMERS

A. Adhesion vs Bond Strength

The term "adhesion" or "adhesion strength" is commonly used to describe the load or stress required to separate two dissimilar solids at or near their common boundary. In the following paragraphs the point is made that adhesion is an easily defined thermodynamic quantity that is difficult to measure. What is usually measured is more correctly called a boundary strength or more often bond strength or joint strength.

The adhesion between two solids (or a solid and a liquid) has a very specific thermodynamic definition; the work of adhesion (W_A). Consider the idealized experiment shown schematically in Figure III-1A where unit area of solid A is separated from solid B. If we consider that the only work done is to create or eliminate surfaces then the experiment involves generating a unit area of surface A, γ_{SA} , unit area of surface B, γ_{SB} , and eliminate unit area of interface, γ_{SAB} . Then W_A is given by,

$$W_A = \gamma_{SA} + \gamma_{SB} - \gamma_{SAB} \quad [1]$$

For the sake of simplicity we assume that there is no rearrangement of molecules at the interface in separating the two solids and that there is no adsorption of molecules onto the separated surfaces from the surrounding environment.

In general, the work of adhesion is actually a small component of the actual energy to separate two solids. Even in the simplest of cases, separation involves deformational energies (Φ) that are orders of magnitude greater than W_A . Assuming that the surface energies and the deformational energies are additive then we can write for the total work of separation;

$$\Phi_T = \Phi_A + W_A \quad [2]$$

where $\Phi_A \gg W_A$.

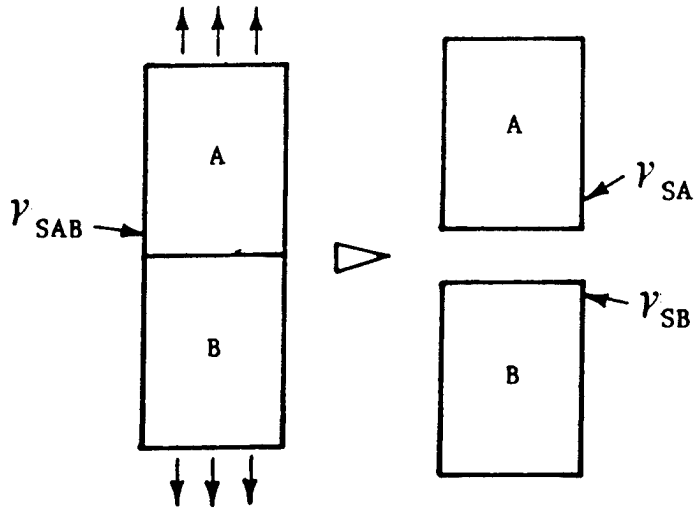

Figure III-1A Schematic of purely surface chemical interfacial adhesion

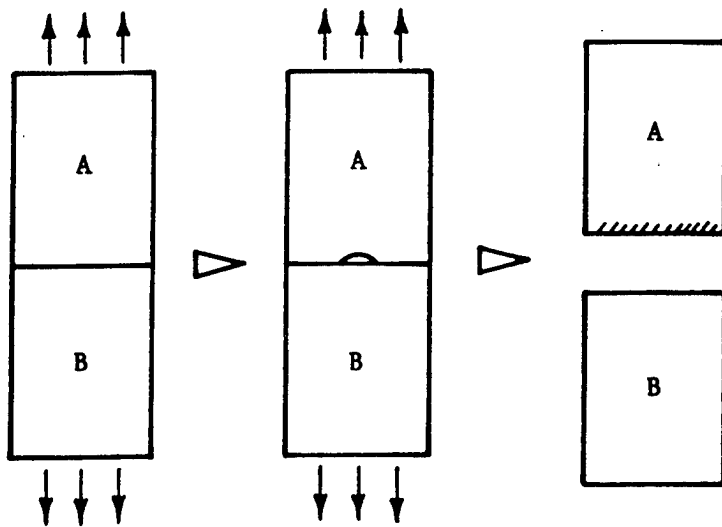

Figure III-1B Interface separation by crack initiation and propagation

Consider a somewhat more realistic situation as shown in Figure III-1B in which we recognize that in order to separate the two solids some form of irreversible deformation is involved. Specifically, if solid A is an epoxy polymer and solid B an aluminum bar, for separation to occur a crack must nucleate and then propagate along the interface. An estimate of W_A made from equation 1 yields a value of $\sim 120\text{mJ/m}^2$ based on surface energetics alone. In a study of aluminum/epoxy butt joints (34) it was found that the energy to fracture the interface was actually 2×10^9 mJ/m^2 , 7 orders of magnitude greater than W_A .

The point of this discussion is that in the great majority of "adhesion" tests what is actually being measured is a joint or bond strength and that the larger part of this strength involves plastic deformation of one or both of the adherends. Unfortunately, this simple fact is often ignored in efforts to correlate surface chemical parameters with bond strength. Such correlations are usually fortuitous or at best coincidental.

For a very instructive illustration of how deformational energies generally dominate joint strength the reader is referred to a study by

Ahagon and Gent⁽³⁵⁾ on the adhesion of an elastomer to glass. Over a wide range of strain rates the peel strength was dominated by the irreversible deformation of the elastomer and only at strain rates that were large compared to the relaxation times of the elastomer was the work of peeling comparable to the thermodynamic work of adhesion; $\Phi_T \sim W_A$.

A study pertinent to the purposes of this report illustrates the complexities of measuring an interfacial strength. Roselman and Tabor⁽³⁶⁾ studied the friction between two crossed carbon filaments using the apparatus shown schematically in Figure III-2. They found the frictional (static) forces were finite even in the absence of an applied load; there is a measurable force of adhesion between the contacting filaments (Figure III-3). From this adhesion strength, Tabor estimated a surface energy for Type II fibers to be $\sim 80 \text{mJ/m}^2$. This is a reasonable value compared to 40mJ/m^2 for the graphite basal planes considering that the surface of carbon fibers includes high surface energy edge planes as well as basal planes.

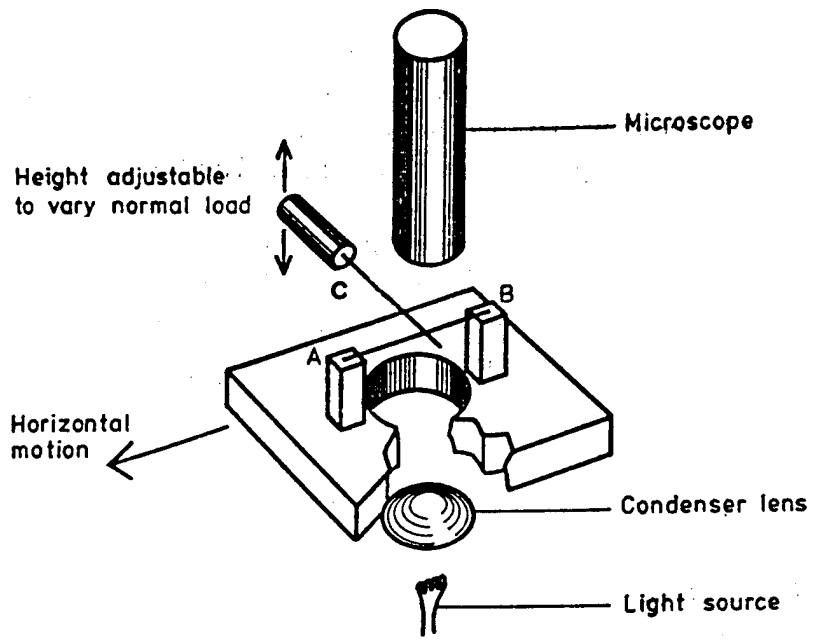

Figure III-2 Schematic of single filament friction test (36)

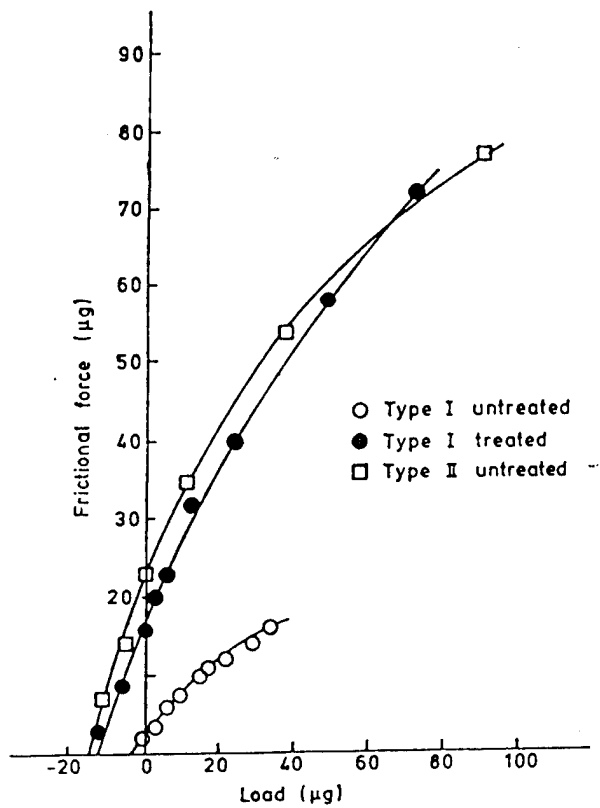

Fig. III-3 Static frictional force of crossed fibres as a function of normal load

Tabor also computed the interfacial shear strength between the carbon filaments at the no load condition. Surprisingly he found an apparent shear strength of 200MN/m^2 . This value is nearly 100X the basal plane shear strength of graphite crystals and close to the theoretical shear strength of single crystal graphite ($\sim 600\text{MN/m}^2$). Tabor concluded that at very low contact loads, the surface of the fiber exhibits a very high deformational resistance to shear. In terms of equation 2 the value of W_A is reasonable but Φ_A is unexpectedly high. Tabor suggests that the surface layers of the fiber are much more flexible and deformable than would be expected from the Young's modulus of bulk graphite. Consequently, the static friction (the bond strength) is very high (~ 7) at low loads. At high contact loads (10^3 – 10^5 mg) the static coefficient of friction falls to 0.2–0.5 which corresponds to the surface layers having an effective modulus close to that of bulk graphite. It would appear that the surface of the CF used in this study behaved more like a highly viscous semi-solid than a rigid brittle solid at low contact pressures. At high contact loads, the surface structure evidently consolidates and behaves as a rigid solid.

The study by Tabor illustrates two complexities that always exist in considering adhesion between two solids. The first has already been stated; the joint strength can be very dependent on the stress condition at the interface. The second point is that it is difficult, if not impossible, to determine a unique interface between two solids. The high

coefficient of friction at low contact loads suggests a surface layer of some macroscopic depth (not a mathematical plane) that is structurally quite different from the interior of the fiber. Moreover, the surface has some degree of rugosity; contact at low loads involves only a few surface asperities. This surface layer constitutes part of the interphase between fiber and matrix and influences the bond strength between the two phases. Figure III-4⁽³⁷⁾ illustrates the interphase between CF and a polymer matrix and includes variations in both the matrix as well as the fiber properties. In any attempt to understand the strength between fiber and matrix it is necessary to characterize this interphase region and identify the locus of failure for different stress conditions.

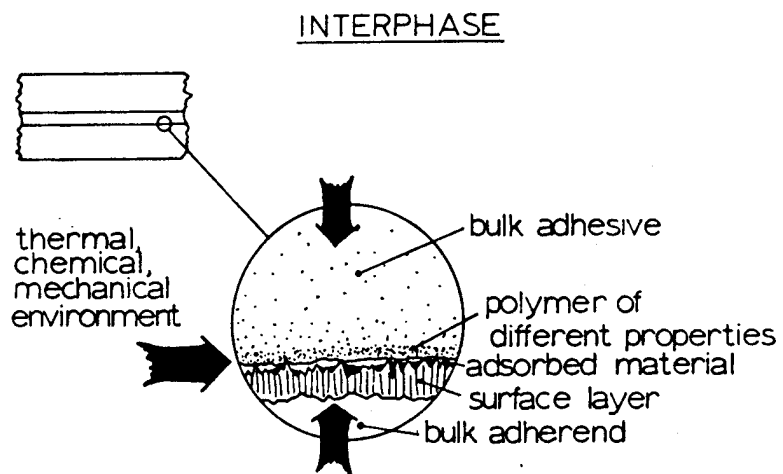

Figure III-4 Schematic representation of the components of the three dimensional interphase between fiber and matrix. (37)

B. Adhesive Interfacial Shear Strength

The measurement of adhesive "interfacial" shear strength can be conducted in two ways. Composite specimens can be made and standard short beam shear, four point shear, or flexural strength tests can be conducted which generates a "number" attributable to an interfacial shear strength. However, the state of stress in these specimens is rarely simple inplane shear at the interface between matrix and fiber (Section III-A).

The other approach is to measure an "interfacial" shear strength using a single fiber type of test. This has its limitations in that it is conducted on an isolated single fiber and is therefore not a true composite test. However, the reduction in ambiguity of the results makes delineation of interfacial failure mechanisms and strengths easier. Comparisons between fibers with different surface treatments and the detection of true interfacial phenomena is achievable. The various single fiber test geometries are shown schematically in Figure III-5. (See Table III-1 for definitions).

Table III-1

Definition of Symbols in Figure III-5

τ = interphase shear strength
F = applied force
d = fiber diameter
 l = embedded fiber length
 l_c = fiber critical length
 σ_f = fiber strength
 G_m = matrix shear modulus
 E_f = fiber tensile modulus
 T_m = interfiber spacing

Single fiber methods for measuring interfacial shear strength

I. Pull-out method

(38)

$$\tau = \frac{F}{A} = \frac{F}{\pi d l}$$

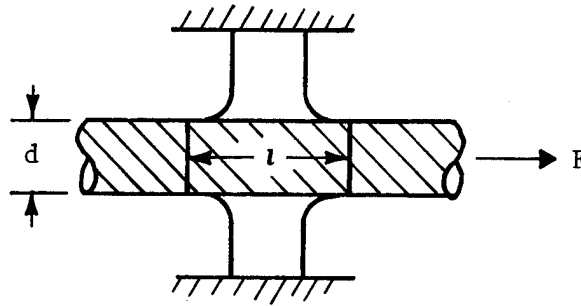

II. Microbond method

(39)

$$\tau = \frac{F}{A} = \frac{F}{\pi d l}$$

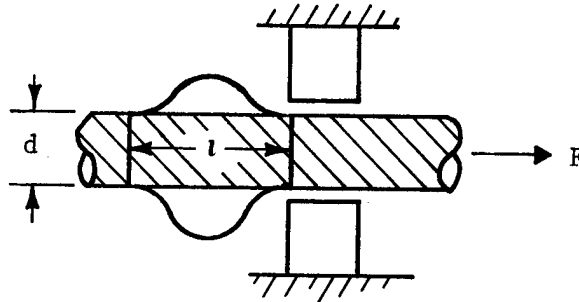

III. Embedded interfacial shear method

(37)

$$\tau = \frac{\sigma f d}{2 l_c}$$

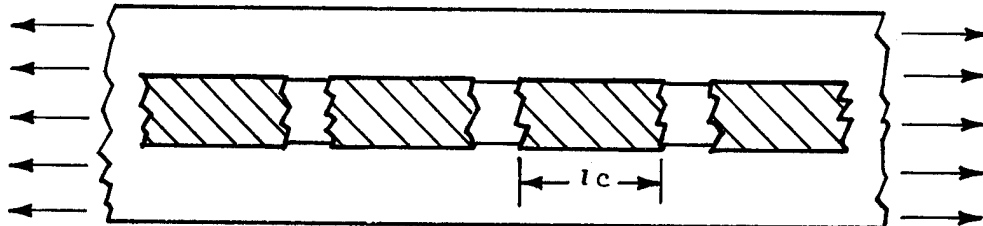

IV. Microdebond

(42)

$$\tau = \frac{\sigma}{2} \left(\frac{G_m}{E_f} \right)^{\frac{1}{2}} \left(\frac{D F}{T_m} \right)^{\frac{1}{2}}$$

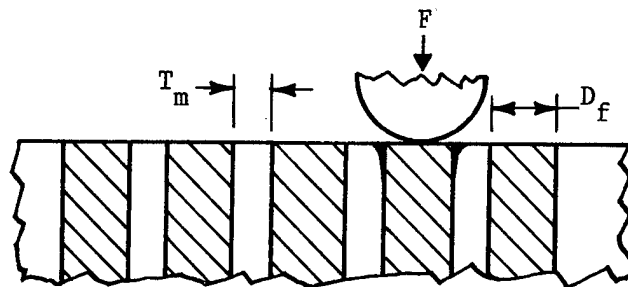

Figure III-5 Schematics of single fiber methods of measuring interfacial shear strengths.

The oldest single fiber test is that of the fiber pull-out⁽³⁸⁾ (Figure III-5). In this experiment a specimen is fabricated in which a single fiber is oriented through a thin disc of the polymer of interest. The disc is thin enough so that the filament can be pulled out of the specimen without breaking. The force required to initially detach the fiber from the disc material and the frictional force required to slide the fiber out of the matrix are recorded. Experiments are conducted where the embedded length is increased up to the point of fiber fracture and the measured force for debonding is plotted versus embedded length. The slope of this line is taken as the shear debonding strength.

Practically, assumptions of a uniform shear stress distribution along the fiber embedded length are assumed. Scatter in the data is quite high. The shape of the polymer meniscus at the point where the fiber comes out of the disc causes undesirable stress concentration factors that contribute to high scatter. The state of stress under these pull-out loading conditions creates a normal tensile stress which acts to pull the matrix away from the fiber at the exit point. This is the opposite of what is observed in a composite.

A variation of this technique has recently been developed in which a droplet of polymer is formed on the fiber instead of the fiber passing through a supported disc (Figure III-5). The droplet is cured in a conventional manner and the fiber is pulled out of the droplet as before.

The major difference is that the small droplet contracts due to surface tension effects into an ellipsoidal shape having a smooth curving boundary where the fiber exits from the drop. This reduces but does not eliminate the stress concentration factor and the variability in the data observed with this technique decreases⁽³⁹⁾.

Some results have been published using the pull-out technique with carbon fibers. The limited number of such results are in some part due to the difficulty in handling small brittle filaments ten microns or less in diameter. Published results for carbon fibers in epoxy matrices show a dependence of the interfacial shear strength on fiber treatment conditions^(40,41).

A second approach to the measurement of interfacial shear strength is through the use of a totally embedded fiber. Advantage is taken of the mismatch in strain-to-failure of the brittle fiber and a ductile resin. A tensile specimen is fabricated in which a single fiber is oriented axially within the test coupon (Figure III-5). Under tensile loading, shear forces are transferred from matrix to fiber at the interface. The transfer causes the build-up of tensile forces in the fiber until the local tensile strength of the fiber is exceeded. The fiber fractures within the polymer coupon. This process is repeated until the fragments remaining are no longer large enough to support sufficient shearing forces to exceed the fiber tensile strength. At this point the fragment lengths remaining represent the critical transfer length for reinforcement. A simple force

balance relates this length, the fiber perimeter and the fiber tensile strength at this critical length to an interfacial shear strength.

The advantage of this method of measurement is that the upper limit to interfacial shear strength is the matrix shear strength, the state of stress more closely resembles what is encountered in an actual composite, and the actual fiber-matrix interface can be observed with polarized transmitted light. The fiber tensile strength can be measured independently as a function of length or surface treatment. The fiber fragment length and diameter are measured in-situ for transparent polymers and can be determined by dissolution and filtering or combustion of the matrix for translucent or opaque materials. The resulting parameter, the interfacial shear strength, still is based on the assumption of a uniform stress distribution in the fiber fragments.

Various authors have published interfacial shear strength measurements with carbon fibers and epoxy matrices. The values obtained (Table III-1) on similar fibers in similar matrices agree quite well.

Table III-1
Fiber-Matrix Interfacial Shear Strength

<u>Fiber</u>	<u>Resin</u>	<u>τ(MPa)</u>	<u>Method</u>	<u>Reference</u>
AU	Epoxy	24	Embedded Single Fiber	37
AS	Epoxy	74	Embedded Single Fiber	37
HMU	Epoxy	14	Embedded Single Fiber	37
HMS	Epoxy	20	Embedded Single Fiber	37
AU1	Epoxy	46	Embedded Single Fiber	30
AS1	Epoxy	77	Embedded Single Fiber	30
AU4	Epoxy	35	Embedded Single Fiber	30
AS4	Epoxy	70	Embedded Single Fiber	30
AS6	Epoxy	60	Embedded Single Fiber	30
IM6	Epoxy	64	Embedded Single Fiber	30
C6000	Epoxy	68	Embedded single Fiber	41
C6000	Epoxy	45	Micro Debond	42
T300	Epoxy	89	Micro Debond	42

A third type of test recently proposed is a hybrid between single fiber testing and composite testing (Figure III-5). A polished cross section of actual composite is prepared and placed under a specially constructed microscope. A spherical indenter of about the same size as the fiber is positioned over a fiber end and loaded until a force of detachment between fiber and matrix is detected with an integral transducer. The load is

input for a micromechanical model which is then used to calculate an interfacial shear strength. The advantage of the method is that it is applied to an actual composite specimen. The disadvantage is that a thorough understanding of the events occurring at the point of debonding is not available. The load measured has not been shown to be attributable entirely to the debonding process⁽⁴²⁾.

C. Adhesive Tensile Strength

The interfacial shear strength is obviously an important strength parameter of any fiber-matrix combination. Other loading directions can arise which do not depend on the fiber-matrix shear strength however. For example, under transverse loading, it is the fiber-matrix interphase tensile strength normal to the fiber surface which is important. A single fiber method for measuring that component of the interfacial strength is available.

A compression specimen of polymer with a single fiber located centrally through the axis of the specimen is fabricated and loaded in compression (Figure III-6). The hour-glass shape of the sample maintains a stable compressive load on the specimen and makes use of the Poisson's effect to concentrate a normal tensile force perpendicular to the fiber axis in the center of the specimen. Using reflected light it is possible to detect the load at which the matrix debonds from the fiber. This value can be used to calculate an interfacial tensile strength.

Practically this method had been used primarily with glass fibers. Attempts to use it with carbon fibers have been unsuccessful because of the compressive fracture of the fiber preceding the actual point of interfacial separation.

D. Polymer Properties Near the Interface

It is unlikely that the properties of the matrix polymer in the interphase region are identical to the bulk polymer properties. There are a number of possible polymer-fiber interactions; selective adsorption of matrix components, conformational effects, penetration of polymer molecules into the fiber surface, diffusion and interaction of low MW components from the fiber, and catalytic effects of the fiber surface on polymer network formation.

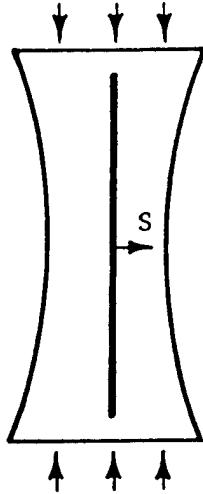

$$S = \frac{\sigma_m (\nu_m - \nu_f) E_f}{(1 + \nu_m) E_f + (1 - \nu_f - \nu_f^2) E_m}$$

where

m, f = matrix, fiber

ν = Poisson's ratio

σ = axial stress at minimum cross-section

E = Young's modulus

Figure III-6 An interfacial adhesion tensile test configuration
(46)

Variations in matrix properties near the carbon fiber surface can be inferred from indirect experiments. Spectroscopic probing would require spatial resolution of one-tenth of a micron or less. Such a probe is not available.

The type of substrate-polymer interaction that can occur is illustrated by a study of the bonding of epoxy matrices cured with an amine curing agent to a copper surface⁽⁴³⁾. This work documented the diffusion and chemisorption of the amine from the bulk polymer to the copper surface. Because of the concurrent diffusion and reaction of the amine, an amine deficient layer of less than a hundred nanometers in thickness was created between the surface enhanced and bulk regions.

A similar observation was made in work directed at understanding the role of a resin rich finish on carbon fiber-matrix adhesion⁽⁴⁴⁾. When an amine deficient layer was created around the fiber, matrix fracture resulted under the same loading conditions that had previously given rise to interfacial fracture. The properties of this amine deficient layer were shown to be more brittle than the bulk matrix having the stoichiometric amount of curing agent.

Other matrix properties affecting the interfacial adhesion have been documented in the literature. Semicrystalline thermoplastic matrices have been shown to nucleate and crystallize on the surface of carbon fibers in a

manner different from the bulk polymer. The surface crystallization has been hypothesized as being responsible for improvements in adhesion properties between fiber and matrix⁽⁴⁵⁾.

The commercial sizing agents applied to carbon fiber to reduce fiber damage during processing (Section II-B) undoubtedly affect the interphase composition relative to the bulk matrix. However, there has not been any clear evidence that these sizings affect composite mechanical properties possibly because they are usually formulated to be chemically similar to the matrix resin so that any interdiffusion of sizing and matrix does not produce a strong gradient in properties through the interphase region.

A number of research studies have been reported on fiber sizings or coatings "tailored" to improve composite properties. Subramanian⁽⁴⁶⁻⁴⁸⁾ has reported extensively on electro-deposited coatings and publications by McMahon, Ying and Maximovich^(50,51) compare various sizings against a commercial epoxy-based sizing. For the most part the effects of the different sizings were relatively small and frequently involved a trade-off in properties, e.g., an increase in impact strength but a decrease in tensile and/or shear properties.

A special type of sizing is the "innerlayer" that is applied to create a gradient in mechanical properties between fiber and matrix. The theoretical mechanics of a low modulus innerlayer have been developed by

Savin⁽⁵²⁾ and by Arridge⁽⁵³⁾. Numerous attempts have been made to develop low modulus innerlayers but with mixed effects on composite properties. Some of the electrodeposited coatings developed by Sabramanian were designed to be low modulus innerlayers. Kardos, Cheng and Tolbert⁽⁵⁴⁾ showed that the development of a crystalline layer at the CF/polycarbonate interface significantly improved composite properties. Williams and Kousiounelos⁽⁵⁵⁾ describe a system of a thermoplastic coating with thermoplastic microfibers in a CF/epoxy composite. Some of their data are shown in Table III-2. For three different laminate configurations they show an improvement in both tensile strength (except for [0°]) and notched fracture stress, K_q .

Recently, McGarry, et al.⁽⁵⁶⁾ have extended their investigations of elastomeric additives for crosslinked glassy polymers (epoxys, polyesters) to the use of these elastomers as thin (50-70nm) coatings on carbon fiber reinforcement.

Tensile Strength and Fracture Toughness (K_q)

Table III-2

Laminate <u>Configuration</u>	Composite <u>Property</u>	Polysulfone <u>Coating</u>	<u>No Coating</u>
$[0, \pm 45^\circ]_s$	σ_f^*	452	375
$[0 \pm 45^\circ]_s$	K_q^{**}	13.9	8.5
$[0^\circ, \pm 45^\circ, 0]_s$	σ_f^{**}	540	396
$[0^\circ, \pm 45^\circ, 0]_s$	K_q^{***}	17.2	8.7
$[0^\circ]$	σ_f^{**}	587	664
$[0^\circ]$	K_q^{**}	27.1	6.8

* unnotched tensile strength, MN/m^2 , normalized to constant fiber volume fracture

**notched fracture stress intensity, $\text{MN/m}^{3/2}$

E. Interfacial Processing Conditions

The processing of polymeric composites brings the polymer into intimate contact with the fiber surface. Because most polymers are relatively high viscosity fluids in the molten state, processing variables, such as time, temperature and pressure become very important for insuring intimate contact. Carbon fiber surface chemical composition, thermodynamic properties such as fiber surface free energy and polymer surface free

energy, surface topographical features, and other surface and interfacial properties are potentially useless in either promoting or predicting fiber-matrix adhesion if true equilibrium intimate molecular contact is not achieved at the interface.

This has implications for various processes which take place during the formation of the fiber-matrix interphase. The first process to occur is the wetting of the carbon fiber by the molten polymer. The macroscopic parameter characteristic of this process is the viscosity. Temperature increases can be used to reduce the viscosity to a minimum value for a given polymer. Pressure and time can be used to extend the contact time and promote interaction at the molecular level.

After intimate contact has been achieved the surface and interfacial forces acting in the region can alter the local composition. In polymers of identical composition for example, oligomers of different molecular weight can exist which although chemically identical can have different surface free energies. Under surface free energy driving forces, longer molecular weight components would be preferentially adsorbed at the interface. The time required for this equilibration by molecular weight would depend on the self-diffusion properties of the polymer chains. A processing time of very short duration would not allow this equilibrium condition to be achieved. On the other hand, a long processing time may promote a segregation by molecular weight that may be desirable or undesirable depending on how it affects interphase properties.

The same type of segregation can occur by differential adsorption. In thermoset systems preferential adsorption may drive one component to the fiber surface. The attainment of an adsorption equilibrium may never be achieved if the time and temperature conditions are not correct. High temperatures allow faster diffusion but increase the reaction rate causing early formation of the crosslinking polymer network. Even under equilibrium conditions there is no a priori reason why the composition of the adsorbed phase should be identical to that of the bulk phase.

The phenomena of epitaxial crystallization has been shown to occur with carbon fibers in semicrystalline thermoplastics. Here again there is a nucleation step which is the precursor to crystallization. Crystallite growth then exhibits a time and temperature dependency which varies with the polymer structure.

Finally as has been shown earlier, significant quantities of potentially volatile materials desorb from the fiber surface under temperatures encountered during composite processing. The removal of these volatile materials is important to achieving molecular contact. If the volatiles are not removed with the application of vacuum before consolidation, they may create voids at the fiber-matrix interface. The only possible mechanism for removal after consolidation of the matrix is by dissolution into the matrix and diffusion away from the fiber-matrix interface. While the amount of materials volatilized is potentially very

small (one monolayer equivalent), the local concentration of desorbed material (water, carbon monoxide and carbon dioxide) can be quite high. This situation will be aggravated if the desorbed material is poorly soluble in the surrounding matrix polymer.

F. Fiber/Matrix Adhesion and Composite Mechanical Properties

Tensile (0°) Strength The primary function of the matrix resin in a fiber reinforced composite is to transfer stress between filaments. In experiments with single filaments embedded in resin it is a relatively simple matter to show that the level of stress transfer into the filament is directly related to the strength of the bond between matrix and fiber (see Section III-B). In a fiber tow or laminate the situation is more complex. If a fiber breaks, the matrix translates the load to the neighboring fibers. However, at the broken fiber ends there is region of stress concentration and unless dissipated may induce failure in adjacent fibers and precipitate catastrophic failure of the tow or laminate. Actually, there is a high shear stress concentration at the tip of a broken filament which can cause interphase debonding and relieve local stress concentrations. Although the details are obscure and subject to debate, there is general agreement that some local cluster of fiber breaks (critical cluster) must develop in order for the tow or laminate to fracture. Both theory^(57,58) and experiment⁽⁵⁹⁾ support the concept of a critical cluster and a large body of literature has developed around this concept.

In the context of this report, it would appear that for maximum tensile strength the bond between fiber and resin must be sufficient to allow stress transfer from resin to fiber but sufficiently weak to fail in shear to relieve stress concentrations in the vicinity of a fiber break.

Transverse (90°) Strength In the transverse direction, the fiber-resin interface is subjected to tensile stresses. Finite element analysis indicates stress magnification at the interface⁽⁶⁰⁾ and it has been suggested that fiber debonding is the probable cause of transverse crack initiation. Bailey and co-workers⁽⁶¹⁾ have studied transverse cracking in 0°/90°/0° laminates and present evidence that crack propagation is close to the fiber resin boundary.

In recent work Adams, et. al.⁽⁶²⁾ used a finite element method (FEM) analysis to characterize the micromechanics of transverse failure. An example of the results of this analysis is given in Figure III-7 which shows one quadrant for a carbon fiber in a high modulus epoxy matrix. Note that the analysis predicts matrix yielding in the region along the 0° direction and that subsequent fracture leads to matrix cracking and apparent interfacial failure. This study included various matrix resins, the effect of thermal stresses and adsorbed moisture on transverse strength. There was good agreement between predicted failure load and experimental test results when a maximum normal stress failure criteria was used. At elevated temperatures and moisture adsorption levels, the

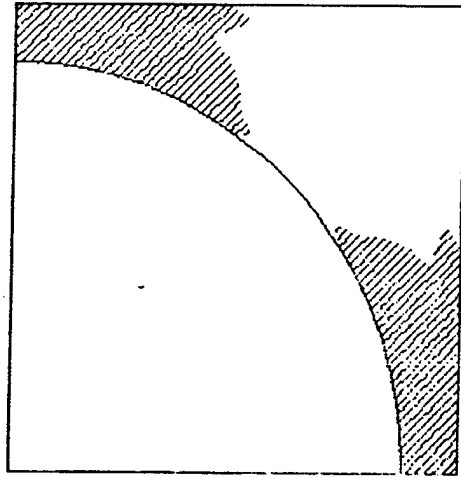

a) No Mechanical Loading



b) $\bar{\sigma}_x = 14 \text{ MPa (2.0 ksi)}$



c) $\bar{\sigma}_x = 25 \text{ MPa (3.6 ksi)}$

Figure III-7 Transverse tensile loading: 3501/AS-4 unidirectional composite, 25°C, < 40% RH. Shaded areas, matrix yielding, dark areas matrix fracture (62)

analysis is "corrected" for some assumed percent degradation of the interfacial bond relative to the "perfect bond" developed at 25°C. This combined use of FEM analysis and experimental test data is very powerful in the analysis and prediction of failure micromechanics. However, it should be pointed out that a FEM prediction of interfacial failure is limited to the size of the smallest grid element at the fiber resin boundary and that this element must of necessity be large compared to molecular dimensions. Thus, the interfacial failure predicted in Figure III-7 is near the fiber resin interface but within some relatively macroscopic size element. Indeed, in the model used by Adams, a degradation in bond strength is introduced as a degradation in the matrix properties of the element at the fiber resin boundary. This work is being extended to reduce the interfacial grid size and introduce relevant interphase properties.

Shear Strength Laminate shear tests have been routinely used to evaluate fiber matrix bond strength. It is generally assumed that a condition of in-plane shear exists and that failure occurs by matrix shear yielding, debonding or some combination of both. Indeed there are at least two instances where low interfacial strength has been determined independently (by single fiber tests⁽³⁷⁾) and the corresponding laminate shear strength found to be low. One case is unsurface treated fiber (AU4 vs AS4 in Table III-1) and the other is high modulus fiber (HMS in Table III-1) where the surface of the fiber itself is cohesively weak. Figure II-8 gives an example of the effect of surface treatment on 4-point shear strength. The shear strength for fiber without surface treatment was

significantly low but increased to a plateau level within less than the normal surface treatment level and maintained this plateau level up to surface treatments 120% greater than normal. In this instance the fiber was given various levels of electrolysis treatment both above and below the condition normally used in production. The matrix resin was a tetrafunctional/amine cured epoxy. It was not possible to find treatment levels that gave shear strength intermediate between no treatment and the plateau level. Other studies of surface treatment variations have also found it difficult to find a set of conditions that give intermediate shear strengths. It would appear that the shear tests are not sensitive enough to detect small differences in fiber surface conditions.

Unfortunately, there is a widely held belief that shear tests, especially the short beam shear (SBS, ASTM D2344) test, provide an unambiguous measure of fiber resin bond strength. As already mentioned shear failure involves matrix shear yielding, debonding or some combination of the two. Moreover, the bonding may include cohesive (shear) failure of the fiber surface itself. The possibility of matrix yielding is especially likely in laminates manufactured by prepreg layup which usually result in a distinct resin layer between plys. The misconception that low shear strength test results invariably means low interfacial strength has led to some heroic (and expensive) efforts to increase the chemical functionality on the fiber surface on the assumption that this would improve laminate shear properties.

The type of shear tests can also be a factor. The SBS test specimen, for example, can fail by modes other than in-plane shear, e.g., tensile or compressive fracture, and crushing under the loading bars. The subject of shear testing has been thoroughly documented in the literature^(63,64).

Compression (0°) Strength Laminate failure under unidirectional (0°) compressive loads is not well understood and, in fact, has been the subject of considerable study in recent years⁽⁶⁵⁾. The current theory is that compressive strength is determined by laminate buckling stability. Correlations have been found between the compressive strength and matrix modulus—the stiffer the matrix the better the fiber support. At a more microscopic level, recent evidence has been presented that for organic fibers (Kevlar, PBT) the micro-buckling is determined by the micro-structure of the fiber⁽⁶⁶⁾

To the extent that interphase strength inhibits fiber microbuckling or fiber bundle kinking, one might expect to observe some effect on compressive strength. This possibility is implicit in the analysis by Hahn and Williams⁽⁶⁵⁾. However, Curtis and Marton⁽⁶⁷⁾ found only a small (10%) effect of carbon surface alteration on compression strength.

IV CRITICAL ISSUES

Our present state of knowledge on organic matrix carbon fiber composites as outlined in the preceding sections is severely inadequate as

a base for predicting the effect of the interface on composite properties. There is only fragmentary information about the mechanical properties of the surface of CF or about CF/matrix interphases. Chemical information is equally limited about the CF surface as it is produced, after surface treatment and in the CF/matrix interphase. The situation is made worse by the fact that most of what is known is based on versions of carbon fiber that are no longer produced or, if in production, the manufacturing conditions have been significantly altered to increase production rates. In some instances there have been significant changes in the PAN precursor. There is essentially no information in the open literature on the newer forms of CF such as the intermediate modulus fibers.

In the next few sections questions are posed that need to be answered in order to better characterize CF surfaces, CF/matrix interphase regions and the effect of the interphase on mechanical properties.

A. Properties of CF Surfaces

1. The "as formed" surface of CF is a poorly defined carbonaceous layer that is partly aromatic and partly aliphatic with adsorbed material (including low MW organic materials) and highly reactive sites (unpaired electrons, free radicals, ionic specie). It is probably cohesively weak. This surface begins to equilibrate with the ambient environment as soon as the fiber emerges from the carbonization/graphitization furnaces. Commercial surface treatment processes alter this surface layer by removing

"loose" material and changing its chemical composition. In order to understand the interfacial properties of CF composites it is necessary to characterize this treated surface. The following are some of the essential questions that need to be answered.

- a. How much of the surface treatment process is a mechanical cleaning of loose material and how much is chemical alteration?
- b. Are there significant differences in the effect of different commercial surface treatments?
- c. What are the mechanical properties of the treated surface and how do they vary with depth?
- d. Is the surface layer porous and what is the scale of the porosity?
- e. What is the chemical constitution of the treated surface and how does the chemistry vary with depth?
- f. What is the degree of surface heterogeneity both in topography and chemical constitution? What is the scale of the heterogeneity?

2. There are a variety of techniques that can be used to determine the chemical and mechanical properties of CF surfaces.

- a. Wettability measurements; Sensitive to outer surface molecular constitution (surface specific), provide information on surface heterogeneity and surface energetics.

Experimentally difficult, data analysis in terms of surface chemical composition can be ambiguous.

- b. Surface spectroscopies (Auger, XPS, SIMS); Provide information on atomic and molecular constituents, techniques vary in surface specificity, can be used for depth profile measurements, limited to testing in high vacuum. Examination of single fibers would require development of special equipment.
- c. Thermal desorption; Useful for characterizing physically and chemically adsorbed specie, and surface decomposition at processing temperatures.
- d. Adsorption analysis; Provide information on surface morphology (porosity) and, using chemically specific adsorbents, on chemical composition. The low specific area of CF requires very sensitive analytical detectors.

3. There are critical questions about the mechanical properties of CF surfaces.

- a. What are the modulus and strength of the surface layer? How do they differ in shear, tension and compression?
- b. How do the mechanical properties vary in depth and along the length of the fiber?
- c. Are the mechanical properties different for different surface treatments, do they change with time after surface treatment?
- d. What relationship is there between the mechanical properties of the surface layer and the surface flaws that initiate fiber breakage?

4. The tools available to determine CF surface mechanical properties are relatively limited.

- a. Contact friction: Adhesion strength and static and dynamic friction between contacting filaments can, in principle, give direct information about surface mechanical properties. The technique is very difficult and reported only once in the open literature (39). Nonetheless, it merits further investigation.

- b. Surface Diffraction: Some information about mechanical properties could be derived from surface specific X-ray, electron or neutron diffraction. In many instances low angle scattering techniques would need to be refined or developed.

B. Properties of the Matrix

The molecular properties of the matrix polymer ultimately influence the interphase region. Measurement of these properties are relatively straight forward although it cannot be assumed these bulk properties are unchanged when the polymer contacts the fiber. Some of the essential information needed are;

1. Viscosity (including time/temperature dependence).
2. Surface tension, especially of molten thermoplastics.
3. Chemical composition including reactive groups, molecular weight and weight distribution, impurities, molecular size.
4. Adsorption behavior on CF surfaces including both chemical and physical adsorption, and adsorption conformation (from solution and melt).

C. Properties of the Interphase

1. The properties of the interphase region, both mechanical and chemical, are critical to composite performance. Unfortunately, these properties are difficult to measure directly and the interpretation of indirect measurements are often ambiguous. Some of the essential questions that need study are;

- a. What are the mechanical properties of the interphase region?
How do these properties vary normal to the CF/matrix boundary and along the fiber?
- b. Given the mechanical properties for the interphase, are existing analytical models adequate to predict the effect of the interphase on composite properties?
- c. Is there penetration of matrix molecules into the carbon fiber surface layer? What is the depth of penetration?
- d. Does the fiber surface influence the matrix polymer structure by differential adsorption, polymer conformational effects and/or effecting the cross-linked network structure?
- e. How do sizings affect the interphase? How can sizing coatings be tailored to enhance composite properties.

- f. What are the effects of residual stresses on the properties and structure of the interphase?
 - g. Can CF surfaces nucleate crystallization of matrix polymers, what are the nucleation sites? What are the conditions (thermal history, etc.) for crystallization?.
 - h. What are the conditions for flaw initiation and growth in the interphase region?
2. Some of the methods of studying the interphase region are;
- a. Single fiber shear adhesion tests; The interphase shear strength can be measured by embedded fiber or fiber pull-out (and push-out) tests. If the organic matrix is transparent and photoelastic, the stress birefringence patterns provide useful information.
 - b. Transmission electron microscopy; Cross-sectioning can be used to identify the locus of failure and some microstructural properties of the interphase.

- c. Depth profiling; The interphase region can be analyzed by SIMS or other surface spectroscopy techniques but the experimental conditions must be carefully designed and will require high resolution beam instruments.

- d. Laminate testing; Testing of composite specimens in combination with closed-form or FEM analyses offer considerable potential for discerning the properties of the interphase and its effect on composite properties.

CONCLUSIONS

The overall conclusion of this review is that our state-of-knowledge concerning the adhesion of carbon fibers to organic matrix polymers is unacceptably poor. Two major consequences of this fact are:

1. The adhesion of carbon fiber to thermoplastic polymers is very low so it is doubtful that the full mechanical properties and environmental stability of these composites are being realized.

2. Without some quantitative knowledge of the mechanical (and chemical) properties of the carbon fiber/matrix interphase, it is difficult to realistically model composite mechanical behavior.

Clearly, research is needed to characterize carbon fiber surfaces, their interfacial interactions with organic polymers and the properties of the interphase. This research must be:

1. Interdisciplinary – surface chemistry and physics, mechanical testing and modelling.
2. Exploration of unconventional experimental and analytical approaches.
3. Funded on a short term basis to "fix" the thermoplastic problem and on a long term, high risk, basis to address difficult questions and explore unconventional investigative techniques.

APPENDIX I

Attendees at the workshop on Critical Issues on Carbon Fiber Adhesion, NASA Langley Research Center, Hampton VA, Dec 10-12, 1985.

Prof. Don Adams
Dept. Of Mechanical Engineering
University of Wyoming
Box 3295
University Station
Laramie, WY 82071

Dr. Willard Bascom
Hercules Aerospace Div.
Bacchus Works
Magna, UT 84044

Dr. John Crews
NASA/LaRC
Mail Stop 188E
Hampton, VA 23665-5225

Dr. Jane Crosby, Manager
Product Development Division
LNP Corporation
412 King Street
Malvern, PA 19355

Tad DeVilbiss
Virginia Tech
Chemistry Dept.
Blacksburg, VA 24061

Dr. Ron Dehl
National Bureau of Standards
Bldg 224, Rm. A209
Gaithersburg, MD 20899

Professor Lawrence Drzal
Michigan State University
Dept. of Chemical Engineering
East Lansing, MI 48824-1226

Dr. Jeffrey Hinkley
NASA/LaRC
Mail Stop 226
Hampton, VA 23665-5225

Dr. Paul Hergenrother
NASA/LaRC
Mail Stop 226
Hampton, VA 23665-5225

Mr. Ken Hummel
Hercules Aerospace
Bacchus Works
Magna, UT 84044

Dr. Norman Johnston
Dr. Paul Hergenrother
NASA/LaRC
Mail Stop 226
Hampton, VA 23665-5225

Dr. Robert Landel
Jet Propulsion Laboratory
California Institute of Technology
Mail Code 67-201
4800 Oak Grove Drive
Pasadena, CA 91109

Prof. John Mandell
School of Engineering
Massachusetts Institute of Technology
Cambridge, MA 02139

Dr. Bernard Miller
Textile Research Institute
P.O. Box 625
Princeton, NJ 08542

Dr. Lynn Penn
Midwest Research Institute
425 Volker Blvd.
Kansas City, MO 64110

Dr. R. E. Robertson
Dept of Materials Sci. & Eng.
H.H. Don Bldg
The University of Michigan
Ann Arbor, MI 48109-2135

Prof. George M. Whitesides
Department of Chemistry
Harvard University
12 Oxford Street
Cambridge, MA 02138

Dr. Edwina Ying
Celanese Research Company
86 Morris Avenue
Summit, NJ 07901

Dr. Lincoln Ying
M&T Chemicals, Inc.
P.O. Box 1104
Rahway, NJ 07065

REFERENCES

1. Johnston, N.J.: "Synthesis and Toughness Properties of Resins and Composites", Selected NASA Research in Composite Materials and Structures, NASA CP-2321, August 1984.
2. Coleman, M.M.; and Sluy, G. T.: "Fourier Transform IR Studies of the Degradation of Polyacrylonitrile Copolymers-I," Carbon **19** 123 (1981)
3. Goodhew, P. J.: "A Review of the Fabrication and Properties of Carbon Fibres," Mat. Sci. Eng., **17** 3 (1975)
4. Bennett, S.C.; and Johnson, D.J.: Proc. Fifth London Carbon and Graphite Conference, Vol I, Soc. Chem. Ind., London, 1978, p.377
5. Watts, W.; and Johnson, D. J.: Proc. Third Conf. on Ind. Carbon and Graphite, Soc. Chem. Ind., London, 1971, p.417
6. Perret, R.; and Ruland, W.: "The Microstructure of PAN-Base Carbon Fibres", J. Appl. Cryst. **3** 525 (1970)
7. Johnson, D.J.: Carbon Fibers, Their Composition and Application, The Plastics Institute, 1971, p.57
8. Peters, P.W.M.; and Springer, G. S.: "Effect of Cure and Sizing on Fiber-Matrix Bond Strength," AFWAL- TR - 86- 4054, Sept 84-Sept 86, Wright-Patterson, AFB, , OH.
9. Hopfgarten, F.: "Surface studies of Carbon Fiber with Auger Electron Spectroscopy" Biennial Conf. on Carbon, **13** 288 (1977)
10. Siegbahn, K.; Nordberg, G. "ESCA Applied to Free Molecules," North-Holland Press, Amsterdam, 1969
11. Drzal, L.T.: "The Surface Composition and Energetics of Type A Graphite Fibers," Carbon, **15** 129 (1977).
12. Drzal, L.T.; Meschner, J.A.; and Hall, D.L.: "The Surface Composition and Energetics of Type HM Graphite Fibers," Carbon **17** 375 (1979).
13. Bendure, R.L.: "Dynamic Adhesion Tension Measurements," J. Colloid and Interface Sci., **42** 137 (1973).
14. Adamson, A.W.: Physical Chemistry of Solids, Wiley. N.Y., 1976, p344.
15. Ellison, A.H.; Fox, H.W.; and Zisman, W.A.: "Wetting of Fluorinated Solids by Hydrogen-Bonding Liquids," J. Phys. Chem. **57** 622 (1953).

16. Wu, S., Polymer Interface and Adhesion, Dekker, NY 1982.
17. Fowkes, F.M; and Mostafa, J.A.: "Acid-Base Interactions in Polymer Adsorption," Ind. & Eng. Chem., Prod. Res. and Dev., 17 3 (1978)
18. Ehrburger, P.; and Donnet, J.B.: "Interface in Composite Materials," Phil. Trans. R. Soc. Lond. A294 495 (1980)
19. Donnet, J.B.; and Bansal, R.C.: Carbon Fibers, Dekker, NY 1984.
20. Denison, P.; Jones, F.R.; and Watts, J.F.: "H-ray Photoelectron Spectroscopic Analysis of Barium-Labelled Carbon Fibre Surfaces," J. Mat. Sci. 20 4647 (1985).
21. Drzal, L.T.; Rich, M.J.; Camping, D.J.; and Park, W.J.: "Interfacial Shear Strength and Failure Mechanisms in Graphite Fiber Composites," 35th Proc. Reinforced Plastics and Composites Conference, Soc. Plastics Ind., 1980, p.20-6.
22. Diefendorf, R.J.; and Tokarsky, E.: "High Performance Carbon Fibers," Polym. Eng. Sci. 15 150 (1975).
23. Badami, D.U.; Joiner, J.C.; and Jones, G.A.: "Microstructure of High Strength, High Modulus Carbon Fibres," Nature 215 386 (1967).
24. Chen, K.J.; and Diefendorf, R.J.: Progress in Science and Engineering of Composites, T. Hayashi, Ed.; ICCS-IV, Tokyo, 1982.
25. Bascom, W.D.; and Boll, D.J. : "Critical Properties Control of Carbon Fiber Reinforcements," Final Report, Air Force Contract AFWAL-TR-82-4165, Air Force Rept., No. H400-12-1-075, December 1982, Hercules Aerospace, Magna Ut.
26. Donnet, J.B.: "Structure and Reactivity of Carbons : From Carbon Black to Carbon Composites," Carbon 20 267 (1982).
27. Boehm, H.P.; Diehl, E.; Heck W.; and Sappock, R.: "Surface Oxides of Carbon" Agnew. Chem., 3 669 (1964).
28. Hopfgarten, F.: "Surface Study of Carbon Fibres with ESCA and Auger Electron Spectroscopy," Fiber Sci. Tech., 11 67 (1978).
29. Hammer, G.E.; and Drzal, L.T.: "Graphite Fiber Surface Analysis by H-Ray Photoelectron Spectroscopy and Polar/Dispersion Free Energy Analysis," Appl. Surf. Sci., 4 350 (1980).

30. Rich, M.J.; and Drzal, L.T.: "Interfacial Properties of Some High-Strain Carbon Fibers in an Epoxy Matrix," 41st Ann. Conf. Reinforced Plastics/Composites Inst., Soc. Plastics Ind., January 1986, p. 2F.
31. Ishitani, A.: "Application of H-ray Photoelectron Spectroscopy to Structure Analysis of Carbon Fiber," *Carbon* **19** 269 (1981).
32. Beitel, G. A. : "The Use of Graphite in High and Ultrahigh Vacuum ; A Review," *Vac. Sci. Tech.* **8** 647 (1971).
33. Kaelble, D.H., Physical Chemistry of Adhesion, Wiley-Interscience, NY, 1971.
34. Bascom, W.D.; Gadomski, S.T.; Henderson, C.M.; and Jones, R.L.: "Fracture Markings on Stress-Corroded Epoxy/Aluminum Butt Joints," *J. Adhesion* **8** 213 (1977).
35. Ahagon, A; and Gent, A.N.: "Effect of Interfacial Bonding on the Strength of Adhesion," *J. Polym. Sci.* **13** 1285 (1975).
36. Roselman, I.C.; and Tabor, D.: "The Friction of Carbon Fibres," *J. Phys. D: Appl. Phys.* **9** 2517 (1976).
37. Drzal, L. T.; Rich, M.J.; and Lloyd, P.F.: "Adhesion of Graphite Fibers to Epoxy Matrices: I. The Role of Fiber Surface Treatment," *J. Adhesion* **16** 1 (1983).
38. Broutman, L.J.: "Measurement of the Fiber-Polymer Matrix Interfacial Strength," Interfaces in Composites, ASTM STP 327, Amer. Soc. for Testing Materials, Philadelphia, PA. 1963, p.133.
39. Miller, B.; Muri, P.; and Rebenfeld, L.: "A Microbond Method for Detemination of the Shear Strength of a Fiber/Resin Interface," *Comp. Sci. and Technol.* **28** 17 (1986).
40. Penn, L.; Bystry, F.; Karp, W.; and Lee, S.: "Aramid/Epoxy vs Graphite/Epoxy; Origin of the Difference in Strength at the Interface," Molecular Characterization of Composite Interfaces, H. Ishida and G. Kumar, Eds., Plenum Pub. 1985, p.93.
41. Ying, L: "Effects of Fiber/Matrix Interactions on the Properties of Graphite/Epoxy Composites," 38th Ann. Tech. Conf., Reinforced Plastics/Composites, Soc. Plastics Ind., 1980, p 20C.

42. Mandell, J.F.; Grande, D.N.; Tsiang, T.H.; and McGarry, F.J.: "Modified Microbonding Test for Direct Insitu Fiber/Matrix Bond Strength Determinations in Fiber Composites," ASTM STP 893, Test and Design, 7th Conf., J. Whitney, Ed., Amer Soc for Testing Mat., Philadelphia, PA, 1986, p. 87.

43. Racich, J.L.; and Koutsky, J.A.: "Boundary Layers in Thermosets," Chemistry and Properties of Cross-Linked Polymers, S. Labona, Ed., Academic Press 1977 p. 303.

44. Drzal, L.T.; Rich, M.J.; Lloyd, P.F.; and Koenig, M.F.: "Adhesion of Graphite Fibers to Epoxy Matrices: II The Effect of Fiber Finish," J. Adhesion, 16 133 (1983).

45. Hobbs, S.Y.: "Row Nucleation of Isotactic Polypropylene on Graphite Fibres," Nature 234 12 (1971).

46. Subramanian, R. U.; and Jakubowski, J.J.: "Electropolymerization on Graphite Fibers," Polym. Eng. Sci., 18 590 (1978).

47. Subramanian, R.U.; Jakubowski, J.J.; "Interphase Resin Modifications in Graphite Composites," ACS Symp. Series, Resins for Aerospace, 132 257 (1980).

48. Subramanian, R.U.; Jakubowski, J.J.; and Williams, R.D.: "Interfacial Aspects of Polymer Coatings by Electropolymerization," J. Adhesion 9 185 (1978).

49. Deleted.

50. McMahon, P.E.; and Ying, L.: "Effects of Fiber/Matrix Interactions on the Properties of Graphite/Epoxy Composites," NASA CR-3607, Sept 1982.

51. McMahon, P.E.; and Maximovich, M.: Advances in Composite Materials, A.R. Bunsell, C.Bathias, A. Martrenehar, D.Menices and G. Verchory, Eds., Vol 2, ICCM 3, Proc. 3rd Inter. Conf. on Composite Materials, Paris, Sept. 1980 Pergamon Press.

52 Savin, G.N.: Stress Concentration Around Holes, Pergamon Press, London, 1961, p.234.

53. Arridge, R.G.C.: "The Effect of Interlayers on the Transverse Stresses in Fiber Composites," Polym. Eng. & Sci., 15 757 (1975).

54. Kardos, J.L. ; Cheng, F.S.; and Tolbert, T.L.: "Tailoring the Interface in Graphite-Reinforced Polycarbonate," *Polym Eng.& Sci.* 13 455 (1973).
55. Williams, J.H.; and Kousiounelos, P.N., "Thermoplastic Fibre Coatings Enhance Composite Strength and Toughness," *Fiber Sci. and Tech.* 11 83 (1978).
56. McGarry, F.J.; Mandell, J.F.; and Kawamoto, J.: "Rubber in Crosslinked Glassy Polymers," *Advanced Composites Conf., Proc. Amer. Soc. Metals, Dec 1985.*
57. Phoenix, S. L.; and Kuo, C.C.: "Recent Advances in Statistical and Micromechanical Modeling of the Time Dependent Failure of Fibrous Composites," *Adv.in Aerospace Structures, Materials and Dynamics*, U. Yuccogin, R.L.Sicrakowski, D.A. Glasgow, Eds., Amer. Soc. Mech. Eng., NY 1983.
58. Manders, P.W.; Bader, M.G.; and Chou T-W.: "Monte Carlo Simulation of the Strength of Composite Fiber Bundles," *Fiber Sci. and Tech.*, 17 183 (1982).
59. Jamison, R.D.: "The Role of Microdamage in Tensile Failure of Graphite/Epoxy Laminates," *Comp. Sci. and Tech.*, 24 83 (1985).
60. Chamis, C.C.: *Composite Materials*, Vol 5, L.J. Broutman and R.H. Krock, Eds., 1974.
61. Bailey, J.E.; Curtis, P.J.; and Poruizi, A.: "On the Transverse Cracking and Longitudinal Splitting of Carbon Fiber Reinforced Epoxy Cross-Ply Laminates and the Effect of Poisson and Thermally Generated Strain," *Proc. R. Soc London*, A366 599 (1979).
62. Zimmerman, R.S.; and Adams, D. F.: "Mechanical Properties Testing of Candidate Polymer Matrix Materials for Use in High Performance Composites," *NASA CR-177970*, Dec 1985.
63. Chiao, C.C. ; Moore, R.L.; and Chiao, T.T.: "Measurement of Shear Properties of Fiber Composites. Part I, Evaluation of Test Methods," *Composites* 8(July) 161 (1977).
64. Whitney, J. M.; and Husman, G.E.: "Use of the Flexure Test for Determining Environmental Behavior of Fibrous Composites," *Exp, Mech*, 18 185 (1978).

65. Hahn, H.T.; and Williams, J.G.: "Composite Failure Mechanisms in Unidirectional Composites," NASA TM-85034, Aug 1984.

66. DeTeresa, S.J.; Porter, R.S.; and Farris, R.J.: "A Model for the Compressive Buckling of Extended Chain Polymers," J. Mat. Sci., 20 1645 (1985).

67. Curtis, P. T.; and Marton, J.: Progress in Science and Engineering of Composites, ICCM-IV, Tokyo, 1982.

Standard Bibliographic Page

1. Report No. NASA CR-4084		2. Government Accession No.		3. Recipient's Catalog No.	
4. Title and Subtitle The Surface Properties of Carbon Fibers and Their Adhesion to Organic Polymers				5. Report Date July 1987	
				6. Performing Organization Code	
7. Author(s) W. D. Bascom and L. T. Drzal				8. Performing Organization Report No.	
9. Performing Organization Name and Address Hercules Aerospace Magna, UT 84044				10. Work Unit No. 505-66-41-04	
				11. Contract or Grant No. NAS1-17918	
12. Sponsoring Agency Name and Address National Aeronautics and Space Administration Washington, DC 20546-0001				13. Type of Report and Period Covered Contractor Report	
				14. Sponsoring Agency Code	
15. Supplementary Notes Langley Technical Monitor: J. A. Hinkley W. D. Bascom: Hercules Aerospace, Magna, Utah (presently at University of Utah, Materials Science and Engineering Department, Salt Lake City, Utah 84112) L. T. Drzal: Michigan State University, East Lansing, Michigan 48823					
16. Abstract The state of knowledge of the surface properties of carbon fibers is reviewed, with emphasis on fiber/matrix adhesion in carbon fiber reinforced plastics. Subjects treated include carbon fiber structure and chemistry, techniques for the study of the fiber surface, polymer/fiber bond strength and its measurement, variations in polymer properties in the interphase, and the influence of fiber matrix adhesion on composite mechanical properties. Critical issues are summarized and research recommendations are made.					
17. Key Words (Suggested by Authors(s)) Carbon fibers Fiber/matrix adhesion Organic matrix composites				18. Distribution Statement Unclassified - Unlimited Subject Category 24	
19. Security Classif.(of this report) Unclassified		20. Security Classif.(of this page) Unclassified		21. No. of Pages 96	22. Price A05