

NATIONAL AIR INTELLIGENCE CENTER



INTERSATELLITE OPTICAL COMMUNICATIONS TECHNOLOGY

by

Zhao Zhaode

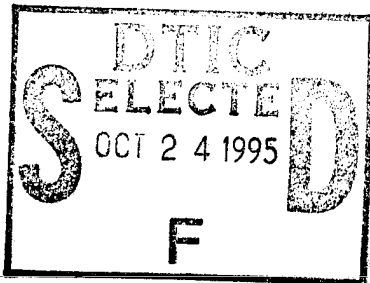

19951023 088

Approved for public release:
distribution unlimited



HUMAN TRANSLATION

NAIC-ID(RS)T-0226-95 1 August 1995

MICROFICHE NR: 95C000450

INTERSATELLITE OPTICAL COMMUNICATIONS TECHNOLOGY

By: Zhao Zhaode

English pages: 13

Source: Aerospace Chine, March 1994; pp. 9-11

Country of origin: China

Translated by: Leo Kanner Associates

F33657-88-D-2188

Requester: NAIC/TASS/Scott D. Fearheller

Approved for public release: distribution unlimited.

THIS TRANSLATION IS A RENDITION OF THE ORIGINAL FOREIGN TEXT WITHOUT ANY ANALYTICAL OR EDITORIAL COMMENT STATEMENTS OR THEORIES ADVOCATED OR IMPLIED ARE THOSE OF THE SOURCE AND DO NOT NECESSARILY REFLECT THE POSITION OR OPINION OF THE NATIONAL AIR INTELLIGENCE CENTER.

PREPARED BY:

TRANSLATION SERVICES
NATIONAL AIR INTELLIGENCE CENTER
WPAFB, OHIO

GRAPHICS DISCLAIMER

All figures, graphics, tables, equations, etc. merged into this translation were extracted from the best quality copy available.

Accession For		
NTIS	CRA&I	<input checked="" type="checkbox"/>
DTIC	TAG	<input type="checkbox"/>
Unannounced		<input type="checkbox"/>
Justification		
By		
Distribution/		
Availability Codes		
Dist	Avail and/or Special	
A-1		

INTERSATELLITE OPTICAL COMMUNICATIONS TECHNOLOGY

Zhao Zhaode

Optical communication between satellites involves the use of laser technology in communicating between satellites, and between satellites and earth station. Since the invention of the laser, there have been more than two decades of research and development of optical communications technology between satellites. The related experiments were conducted by the National Aeronautics and Space Administration in the United States, the European Space Agency, the Japanese consortium of Space Development, among others. Space experimental plans for the late nineties were prescribed.

Laser communications between satellites has unique features of wideband frequencies, high noise immunity, capability of relieving crowded phenomenon of radio frequency usage for laser signals at present. Since light waves are very short, it is possible to use a small-aperture telescope to emit a very narrow wave beam. Therefore, a satellite-borne optical communications

module can be reduced in size and made more compact in structure.

I. Application Range of Optical Communications Technology Between Satellites

According to the application range, the intersatellite optical communications technology can be generally subdivided as follows: data relay satellite systems; group satellite systems; satellite launch; and deep space communication systems, among others.

1. Data relay satellite systems

(1) Relaying (GEO-LEO-HEO) between satellites in geostationary orbits and low and intermediate orbits applies optical communications technique between satellites. By using only three satellites in geostationary orbits, the coverage is effective for satellites operating in most orbits with low and intermediate heights. For example, low orbiting satellites like Landsat can relay data to an earth station through a satellite operating in a geostationary orbit. Satellites operating in a highly eccentric orbit, such as Molniya, can also conduct data relaying with satellites operating in a geostationary orbit.

(2) Relaying between satellites in geostationary orbits (GEO-GEO) can link up in communication with geostationary satellite communication systems of different relaying and missions between the data relaying satellites.

(3) Relaying between satellites in low earth orbits (LEO-LEO) is performed by Motorola's Iridium Satellite System for relaying by using optical links between satellites. Fig. 1 shows the use of optical links for mobile communications between satellites.

2. Group Satellite Systems

At present, four to seven international communication satellites (including reserve satellites) have been deployed by the International Communication Satellite Organization in geostationary orbits over the Pacific, Atlantic, and Indian oceans. These satellites utilize microwaves to link up with earth stations. To adapt to future communication demand, we should consider linking up adjacent satellites among these satellites for group operations. For example, multiple satellites over the Atlantic can use optical link channels for data exchange in orbit. The various earth stations can conduct information transmission through the group satellites.

3. Satellite Launch Support

The optical communication technology between satellites can be applied in rocket tracking and management, and other kinds of support until the satellite enters its orbit. Through the relay satellite system, communication commands of the launch of the aerospace plane can be conducted.

4. Deep Space Communications

This deals mainly with communication between satellites in

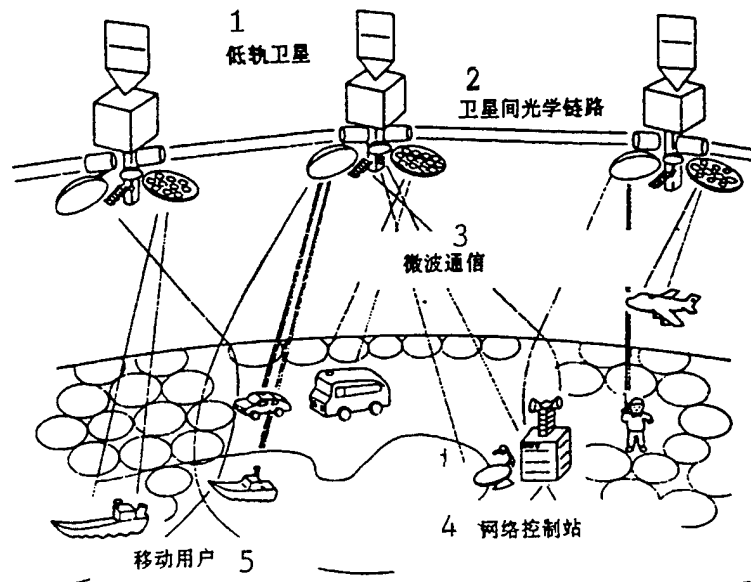

Fig. 1. Schematic diagram showing the optical link channel between satellites in low earth orbit
KEY: 1 - satellites in low earth orbit 2 - optical channel 3 - microwave communication 4 - network control station 5 - mobile users

geostationary orbits and satellites operating in lunar orbits, between the satellite operating in a stationary orbit around the moon and a planet, and a base on the moon or a planet, as well as communication between the ground surface and deep space. In the case of deep space communications, often data should be transmitted at distances of billions of kilometers. As energy decays in proportion to the distance squared, to effectively restrain energy dissipation, a short-wavelength emitted wave beam can be applied. As the wavelength of light is about 1000 times

smaller than that of microwaves, therefore, by using laser technology in deep space communications, a communications system of wideband frequencies, concentrated energy, and high efficiency can be established.

II. Properties of Optical Communications Between Satellites

For the intersatellite optical communication system, the satellite borne equipment is small in size, light in weight, resistant to jamming, and large in communication capacity. However, there are certain difficulties in light communication systems for space applications. Therefore, the related techniques should be developed.

Intersatellite optical communications is communications over ultralong distances. Therefore, it is required to have a receiving system with high output power and high sensitivity.

Intersatellite optical communications is communication between moving bodies at high velocities. Therefore, it is very important to have the technology of acquisition, tracking and orientation. In addition, since there is greater doppler frequency shift generated between moving bodies, so frequency tracking is required in this case.

In optical communications, the transmitting and receiving wave beams are sensitive; however, it is required to revise the optical aberrations of transmission and reception. In addition, the effect of background optical noise should be considered.

In the following, we consider, successively, the

relationship between intersatellite optical communications, on the one hand, and intersatellite distance, doppler frequency shift, predetermined angular revision, and background optical noise, on the other hand.

1. Distance between satellites

When designing an optical communication system between satellites, an important factor is the effective distance between satellites. According to the system design standard, the distance is about 43,000km between a geostationary satellite and a low-earth-orbit satellite; the distance between satellites in geostationary orbit is about 80,000km.

2. Doppler frequency shift

The doppler frequency shift is proportional to the relative velocity and light frequency between satellites. The doppler frequency shift between geostationary satellites is less than 10GHz. When intensity modulation and direct wave detection are applied, generally there is no problem in doppler frequency shift. When the heterodyne method is used in wave detection, then it is necessary to conduct frequency tracking.

3. Pre-determined angular revision

The speed of light is also finite. With light emission in the direction of the receiving wave beam, the light is directly aimed at the other satellite. As it is still operating in orbit,

light aberration is generated with the occurrence of light unable to reach the other satellite. Therefore, it is necessary to apply a predetermined angular revision in advance. The maximum revised angle for light aberration between a geostationary satellite and a low-earth-orbit satellite is 44.9microradians; the maximum revised angle between satellites operating in geostationary orbits is 40microradians.

4. Background light noise

There are generally the following background light noises during intersatellite optical communications: sunlight, reflected and illuminated earth light, reflected and illuminated light of the sun from the moon, illuminated light from bright planets and stars, and gaseous emission light from glows of aerospace planes.

When entering the visual field of the receiving optical system, the signal-to-noise ratio will be reduced. To relieve this effect, the following measure can be used: narrowing the visual field angle of the receiver, employment of narrow-band filters, restriction of energy for incident noise, adoption of aberration wave detection method, and selection of high light power resonance to improve the signal-to-noise ratio.

III. Key Techniques of Intersatellite Optical Communications

The optical communication technology acts on the technical foundation of fiber optic communications. Therefore, the light modulation and demodulation technique can be applied; however,

several new aspects should be developed.

Since there are different output power levels applied, it is required to develop the corresponding optical modulation and demodulation system or optical frequency amplifier. In fiber optic communications, to avoid nonlinear effects of the fiber, often power of less than several milliwatts is employed. However, in the case of intersatellite optical communications, the amount of decay is high because of the ultralong distances of communication. Thus, power upwards of hundreds of milliwatts is required.

The space light source with excellent coherence and high reliability was developed. When using the coherence modulation and demodulation mode, such a light source should be developed with good time coherence.

The light beam control technique is the key in optical communications. Compared with fiber optic communications, since the distance is longer for intersatellite optical communications, it is necessary to effectively perform orientation on light. Compared with microwaves, the wave beam of light wave is 1000 times narrower, it is possible to use high-sensitivity wave beam to very effectively transmit the signals.

The key components and techniques of intersatellite optical communications include the following:

1. optical receiving and transmission dual-use device.

Fig. 2 shows the fundamental setup of a communications installation using light between satellites. The major integral

units in the installation are a light source of semiconductor laser (LD), an optical modulator and demodulator system, an optical wave beam control system, and an optical antenna system, among others.

The wavelength of a light source and for an application should meet the circuitry design requirements of communications capacity, optical output power, transmission distance, gain of optical antenna, sensitivity of photosensitive devices, and background light noise, in addition to the development status of a light source. There are relatively better development prospects in 0.8micrometer lasers, and its excited 1.06mm Nd:YAG laser. Even if shorter wavelength lasers are applied, the equipment can be made smaller. The development trend is to use such lasers with wavelength as short as possible.

Generally, the wave beam shape is elliptical as outputted from a laser device. The position of focus along the long axis/short axis direction has dispersions of different depths as exited from the terminal surface of the laser device. The astigmatism of the emission angles of these light beams is different for different laser devices. In order to have parallel output wave beams, and high transmission efficiency, it is required to use a collimator optical system for a laser emitter. Used for communications, the optical sensor applies the avalanche photoelectronic diode.

2. Optical modulation and demodulation mode

The modulation and demodulation mode can be divided into the intensity modulation/direct detection (IM/DD) mode and the

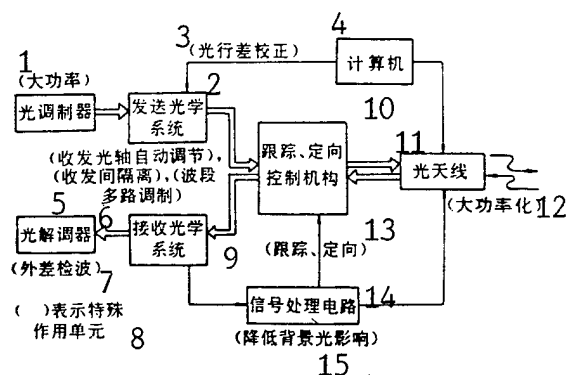

Fig. 2. Fundamental configuration of optical communication setup between satellites
 KEY: 1 - optical modulator (high power)
 2 - emission optical system 3 - revision of optical aberrations 4 - computer 5 - (automatic adjustment of receiving and transmitting optical axes) (separation between reception and transmission), and (wave segment multi-channel modulation) 6 - optical modulator
 7 - (aberration detection of waves)
 8 - (indicates a special action element)
 9 - receiving and transmitting optical system
 10 - tracking, orientation, and control mechanism
 11 - optical antenna 12 - (high power)
 13 - (tracking and orientation) 14 - signal processing circuits 15 - (reducing the effect of background light)

coherent modulation/demodulation mode by considering the signal as high and low power light for transmission.

When applying the IM/DD mode, we should develop such an optical modulator/demodulator with 100mW output power and 300Mbits/s transmission speed. When the transmission speed is

above 1Gbits/s, it is required to develop a high power laser emitter or to adopt such measures of optical frequency amplification, and multiple channels for frequency spectrum. Or, high power and large capacity can be carried out by using an Nd:YAG laser with an external modulation mode.

At the beginning, most intersatellite optical communications were designed with the IM/DD mode. Later, the coherent modulation/demodulation mode could be applied. Theoretically, the PSK mode has the highest sensitivity in the coherent modulation mode.

3. Light Beam Control Technique

Used in intersatellite optical communications, such an optical antenna should have a very sensitive orientation. Thus, correct orientation can be realized when acquiring and tracking the optical wave beam emitted from the other satellite.

In the following, an example is cited for communication between a geostationary-orbit (GEO) satellite and a low-earth-orbit (LEO) satellite to describe the procedure of acquiring, tracking, and orientation of intersatellite optical communications.

(1) Scanning beacon of a GeO satellite within monitoring range.

(2) As emitted from the GEO satellite, the beacon signal

enters the monitoring range of the LEO satellite. The LEO satellite detection beacon signal can determine the direction of the GEO satellite, and emit a communication narrow-wave beam.

(3) The GEO satellite detects the signal emitted by an LEO satellite, thus determining the operating direction of the LEO satellite. In addition, a narrow communication wave beam is applied on the beacon signal.

(4) The GEO satellite cuts off the beacon signal, and the LEO satellite receives the communication wave beam from the GEO satellite, thus establishing a communication link.

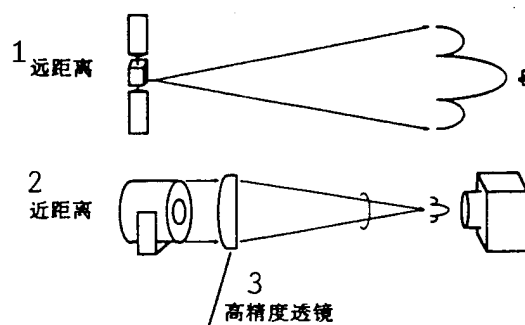

Fig. 3. Simulation setup of laser beam propagation in free space
KEY: 1 - long distance 2 - short distance
3 - high precision lens

The time required is longer in passing through the narrow communication wave beam scanning monitoring region. Generally, the GEO satellite applies expansion beacon device of very wide outputs for rapid acquisition.

4. Laser wave beam transmission simulation attachment in free space

The light beam control technique for intersatellite optical communications can be simulated in advance at the ground surface, to conduct the foundation of related light beam, as well as the controlled experimentation and evaluation, in addition to property evaluation of the acquisition and tracking orientation system, and simulation data acquired for a dual-direction optical communication system.

For this purpose, a laser wave beam propagating simulation apparatus in free space was developed by the Japanese Photoelectronic Communication Research Institute. Fig. 3 is the schematic diagram. By using a lens system in the setup, a determination of the properties in a remote region was realized. In addition, the vibrational properties of wave beams between satellites can be determined. To prevent fluctuations of light beam due to variation of the atmospheric refractive index, the light beam of the apparatus propagates in a vacuum.

DISTRIBUTION LIST

DISTRIBUTION DIRECT TO RECIPIENT

<u>ORGANIZATION</u>	<u>MICROFICHE</u>
B085 DIA/RTS-2FI	1
C509 BALL0C509 BALLISTIC RES LAB	1
C510 R&T LABS/AVEADCOM	1
C513 ARRADCOM	1
C535 AVRADCOM/TSARCOM	1
C539 TRASANA	1
Q592 FSTC	4
Q619 MSIC REDSTONE	1
Q008 NTIC	1
Q043 AFMIC-IS	1
E404 AEDC/DOF	1
E410 AFDTC/IN	1
E429 SD/IND	1
P005 DOE/ISA/DDI	1
1051 AFTT/LDE	1
PO90 NSA/CDB	1

Microfiche Nbr: FTD95C000450
NAIC-ID(RS)T-0226-95