

0982.TX
UNCLASSIFIED

FMPC-344

Subject Category: METALLURGY AND CERAMICS

UNITED STATES ATOMIC ENERGY COMMISSION

DESIGN CHANGE ON THE TWO STONE DRESSING
TOOL USED IN DRESSING THE GRINDING
WHEEL ON A CONTOUR CENTERLESS GRINDER

By
Charles J. Michel

DISTRIBUTION STATEMENT A
Approved for public release
Distribution Unlimited

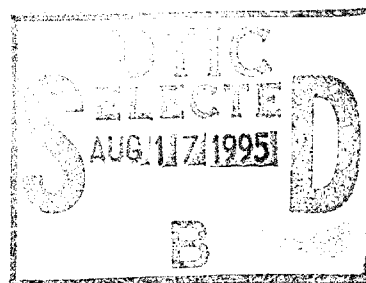

March 18, 1953

National Lead Company of Ohio
Cincinnati, Ohio

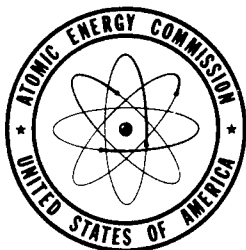

Technical Information Extension, Oak Ridge, Tennessee

19950815 053

UNCLASSIFIED

DTIC QUALITY INSPECTED B

Date Declassified: January 4, 1956.

LEGAL NOTICE

This report was prepared as an account of Government sponsored work. Neither the United States, nor the Commission, nor any person acting on behalf of the Commission:

A. Makes any warranty or representation, express or implied, with respect to the accuracy, completeness, or usefulness of the information contained in this report, or that the use of any information, apparatus, method, or process disclosed in this report may not infringe privately owned rights; or

B. Assumes any liabilities with respect to the use of, or for damages resulting from the use of any information, apparatus, method, or process disclosed in this report.

As used in the above, "person acting on behalf of the Commission" includes any employee or contractor of the Commission to the extent that such employee or contractor prepares, handles or distributes, or provides access to, any information pursuant to his employment or contract with the Commission.

This report has been reproduced directly from the best available copy.

Issuance of this document does not constitute authority for declassification of classified material of the same or similar content and title by the same authors.

Printed in USA, Price 15 cents. Available from the Office of Technical Services, Department of Commerce, Washington 25, D. C.

DESIGN CHANGE ON THE TWO STONE DRESSING TOOL
USED IN DRESSING THE GRINDING WHEEL
ON A CONTOUR CENTERLESS GRINDER

By

Charles J. Michel

of

TECHNICAL DIVISION
NATIONAL LEAD COMPANY OF OHIO

March 18, 1953

Approved by:

F. L. Cuthbert

Director, Technical Division

Approved by:

M. C. Bowski

Head, Metallurgical
Department

National Lead Company of Ohio
Cincinnati, Ohio
Contract No. AT (30-1)-1156

Accession For	
DTIC GRA&I	<input checked="" type="checkbox"/>
DTIC TAB	<input type="checkbox"/>
Unannounced	<input type="checkbox"/>
Justification	
By _____	
Distribution/ _____	
Availability Codes	
Dist	Avail and/or Special
A-1	

TABLE OF CONTENTS

	Page
I. INTRODUCTION	5
II. METHODS AND DATA	5
III. SUMMARY AND CONCLUSIONS	6

ABSTRACT

A new design for a two-stone dressing tool for the grinding wheel of contour centerless grinder is presented which results in a 66 percent increase in the life of the tool at a cost increase of 19 percent.

I. INTRODUCTION

This report presents a design change in a two-stone dressing tool used in dressing the grinding wheel on a contour centerless grinder. The present tool has two small diamonds, sharpened to the proper chisel shape, set in a nib at a 15° angle to the $7/16$ inch diameter shank that fits into the well on the grinder truing attachment (see Figure 1). Since the well in the truing attachment is at a 15° angle, it was thought that the faces of the two diamonds would then be tangent to the grinding wheel. This is true only when the diamonds protrude $15/64$ inch from the truing attachment. The tools presently being used are not designed so that this can be done. A design is presented in this report which meets the specified requirements (see Figure 2).

II. METHODS AND DATA

If the center line of the truing attachment is extended, it becomes a radius of the grinding wheel. Therefore, if the diamonds of the two-stone dressing tool are positioned on each side of this center line, the plane in which the stones are positioned will always be tangent to the grinding wheel. The center line of the tool well intersects the end of truing attachment $1/16$ inch below the center line of the truing attachment. The two center lines form a 15° angle and intersect $15/64$ inch from the truing attachment (see Figure 3).

A new tool was designed with a $1/4$ inch shoulder set at a 15° angle to the $7/16$ inch shank (see Figure 2). This tool was tested under production conditions.

Testing Procedure

A No. 2 Centerless grinder was used for the test. It was equipped with a 2A-180-M6-VN grinding wheel, a standard work-rest blade, and Texaco Sol C mixed ten parts water to one part oil for coolant. The depth of cut for each pass was $.0005$ inch.

Nine tests were made using the regular production tool with a shoulder varying from $1/8$ inch to $3/8$ inch. The thickness of the shoulder was varied to determine the effect of this change on the life of the tool. This variation was accomplished by machining away part of the shoulder in four tests, using the tool as fabricated in two tests and adding a $1/8$ inch shim in one test.

A number of tools which had been used in production and had been sent to the tool room for re-lapping were examined. It was found that when the nose of the diamonds was worn to the degree shown in the figure below, the tool was re-lapped. This amount of wear was used as an end point for determining the tool life in this test.

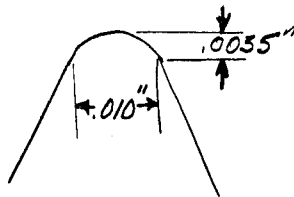

DATA

Test Number	Number of Passes Before Re-lapping Needed	Diamond Tool	Shoulder Thickness
1	30	Production	None
2	30	Production	None
3	35	Experimental	None
4	35	Experimental	None
5	35	Experimental	1/8"
6	35	Experimental	1/8"
7	50	Experimental	1/4"
8	50	Experimental	1/4"
9	25	Experimental	3/8"

III. SUMMARY AND RESULTS

It was found that the life of the new tool was approximately 50 passes and that the production tool had a life of approximately 30 passes. This is an increase in tool life of 66 percent.

The cost of the new tool was approximately \$18.50 per tool on a purchase order of 12 tools. The cost of the production tool was approximately \$15.50 per tool on a purchase order of 100 tools. Disregarding any quantity discount, the increase in cost of the new tool is 19 percent.

The data show that there was a decided decrease in tool life when the shoulder thickness was either less than or greater than $1/4$ inch.

This is primarily a report of a design change and, therefore, the tool presented is not necessarily the only tool which can make use of this design change. One recommendation is to use a Wheel Truing Tool Company stock tool.

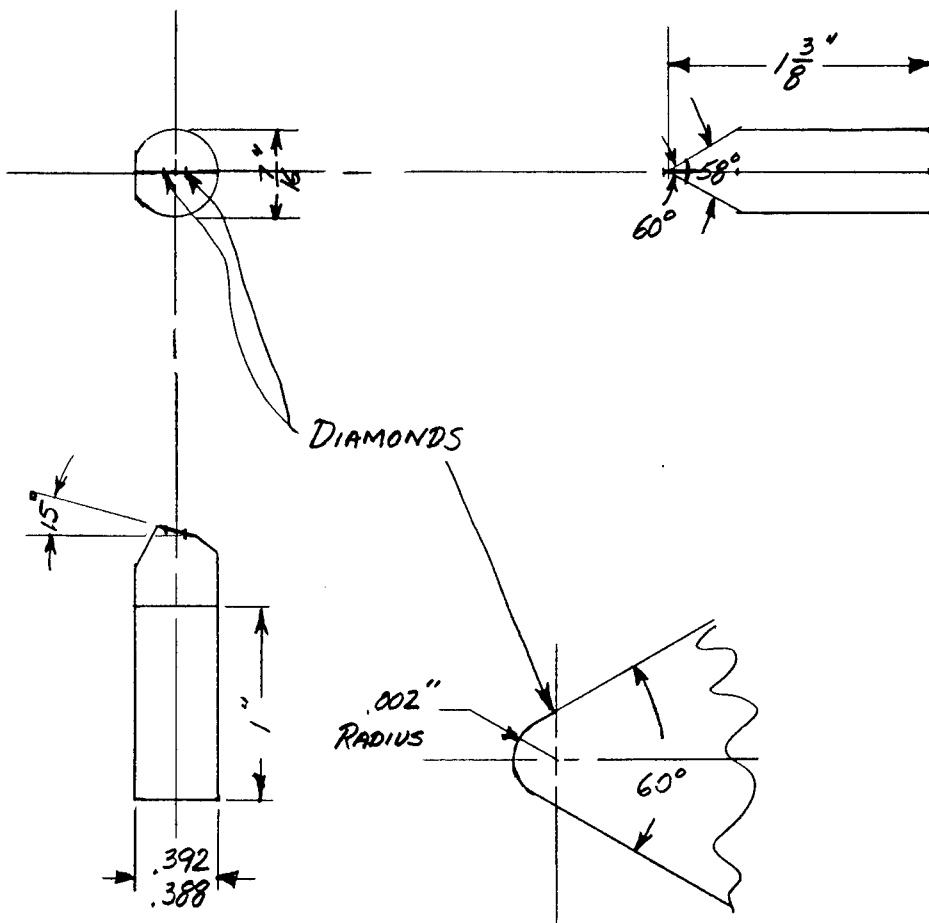

Fig. 1
PRESENT PRODUCTION TOOL

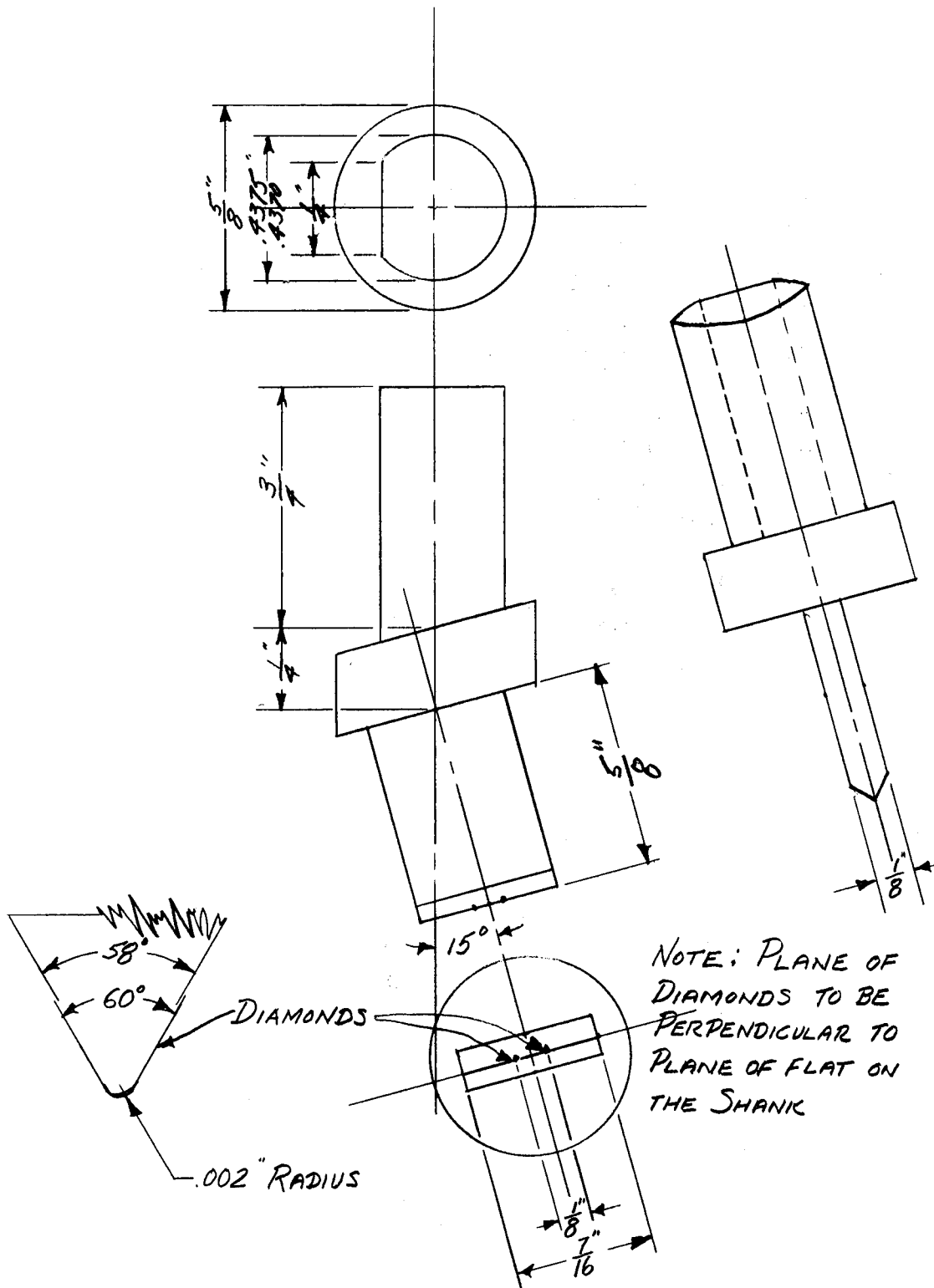

Fig. 2
NEW DRESSING TOOL

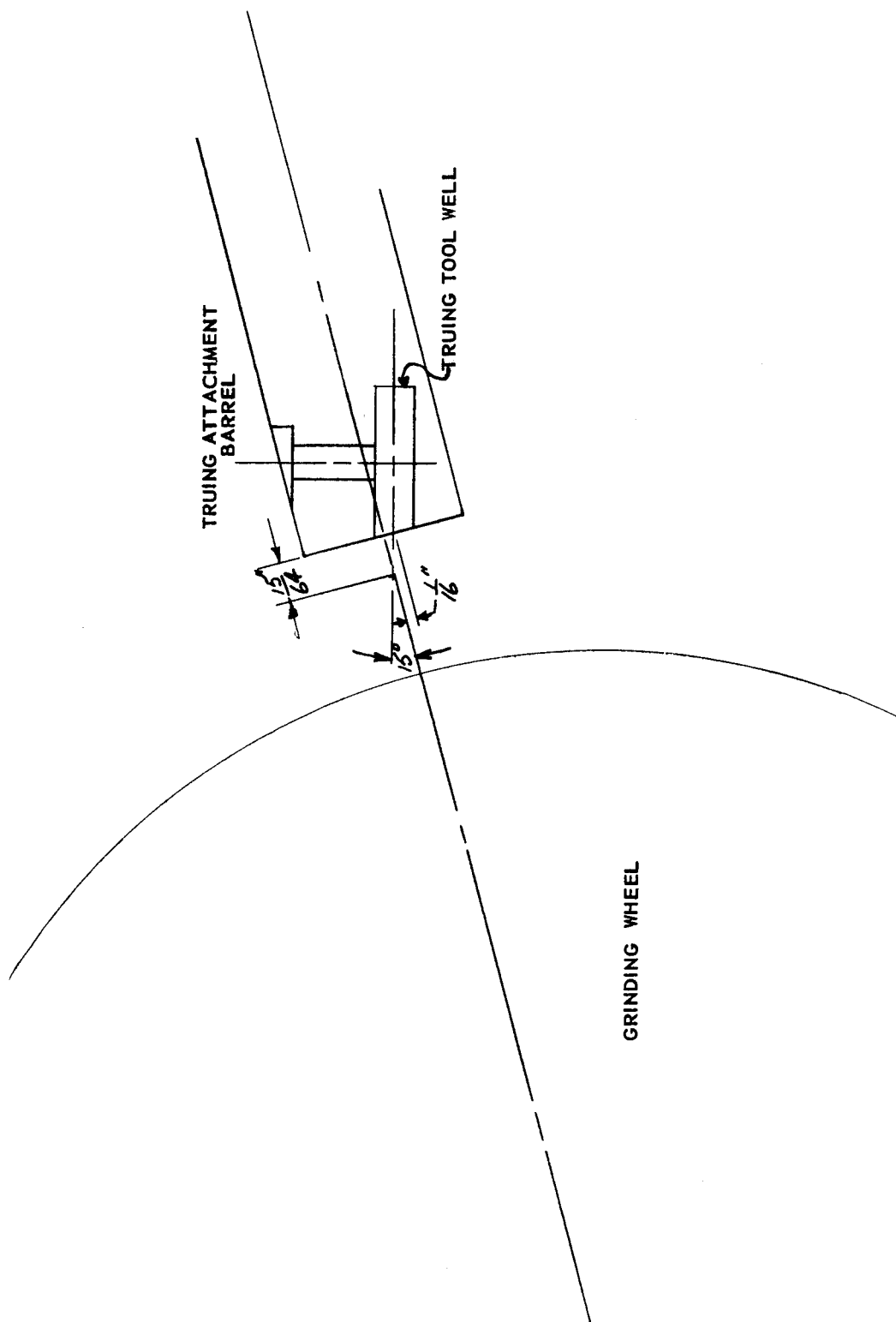

Fig. 3
PRINCIPAL COMPONENTS INVOLVED IN TRUING A GRINDING
WHEEL ON A CENTERLESS GRINDER WITH
A TWO STONE DRESSING TOOL