

Artificial Cells, Blood Substitutes, and Immobilization Biotechnology

Formerly: Biomaterials, Artificial Cells,
and Immobilization Biotechnology

An International Journal

Volume 22
Number 4
1994

Third of 3 Special Issues from
Vth International Symposium on Blood Substitutes

Blood Substitutes and Related Products:
The Fluorocarbon Approach

Guest Editor:
J.G. Riess

19950717 060

Includes Indexes to Volume 22

ARTIFICIAL CELLS, BLOOD SUBSTITUTES, AND IMMOBILIZATION BIOTECHNOLOGY

September 1994

Aims and Scope. This journal covers artificial cells, blood substitutes, and immobilization biotechnology. The emphasis of this journal is to allow for interdisciplinary interactions. Therefore, we welcome approaches based on biotechnology, chemical engineering, medicine, surgery, biomedical engineering, basic medical sciences, chemistry and others. The following areas are particularly welcomed.

1. Immobilized bioreactants including cells culture, microorganisms, enzymes, drugs, receptors, sorbents, immunosorbents and other biologically active molecules.
2. Artificial cells, microcapsules, liposomes, nanoparticles and other carriers.
3. Blood substitutes from fluorocarbon, modified hemoglobin, encapsulated hemoglobin, synthetic heme, recombinant hemoglobin, and others. Chemistry, methods, in-vitro studies, in-vivo evaluations and clinical results.
4. Microencapsulation and other methods of immobilization of cells (e.g. hybridoma, endocrine cells and liver cells, etc.) or microorganisms. Cells immobilized by different approaches. Methods, evaluation, and applications. Cell culture technologies related to immobilization. Hybrid artificial organs based on cell cultures.
5. Enzyme replacement, enzyme therapy, immunosorption, detoxification, hemoperfusion, metabolite conversions and drug delivery.
6. Design, evaluation and clinical application of hemoperfusion, artificial kidneys, plasmapheresis, and other artificial replacements.
7. Synthetic and biological biomaterials related to artificial cells and immobilization biotechnology. Blood compatible materials. Synthesis, biocompatibility, blood compatibility and evaluations.
8. Biotechnologically derived biologically active molecules related to artificial cells and immobilization biotechnology.
9. Drug delivery systems.
10. Other related areas including new approaches using biotechnology, computer, and other novel high technology.

Identification Statement. *Artificial Cells, Blood Substitutes, and Immobilization Biotechnology* (ISSN: 1073-1199) is published five times a year in March, May, July, September, and November for the institutional rate of \$615.00 and the individual rate of \$307.50 by Marcel Dekker, Inc., P.O. Box 5005, Monticello, NY 12701-5185.

Volume	Issues	Institutional Rate	Individual Professionals' and Student Rate	Foreign Postage		
				Surface	Airmail to Europe	Airmail to Asia
22	5	\$615.00	\$307.50	\$18.75	\$27.50	\$32.50

Individual professionals' and student orders must be prepaid by personal check or may be charged to MasterCard, VISA, or American Express. Please mail payment with your order to: Marcel Dekker Journals, P.O. Box 5017, Monticello, New York 12701-5176.

CODEN: ABSBE4 22(4) i-xx, 945-1544 (1994)

ISSN: 1073-1199

Printed in the U.S.A.

AD _____

GRANT NO: DAMD17-93-J-3024

TITLE: Symposium on Blood Substitutes: New Frontiers

PRINCIPAL INVESTIGATOR(S): Robert M. Winslow, M.D.

CONTRACTING ORGANIZATION: University of California, San Diego
San Diego, California 92161

REPORT DATE: May 1994

TYPE OF REPORT: Final - Proceedings
Volume 22, Number 4

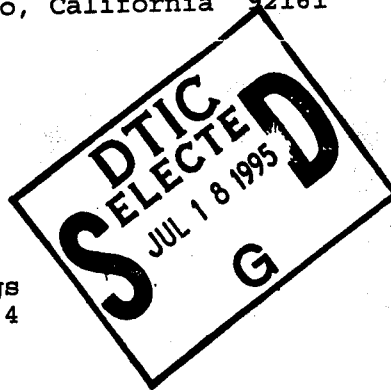

PREPARED FOR: Commander
U.S. Army Medical Research and Materiel Command
Fort Detrick, Maryland 21702-5012

DISTRIBUTION STATEMENT: Approved for public release;
distribution unlimited

The views, opinions and/or findings contained in this report are those of the author(s) and should not be construed as an official Department of the Army position, policy or decision unless so designated by other documentation.

REPORT DOCUMENTATION PAGEForm Approved
OMB No. 0704-0188

Public reporting burden for this collection of information is estimated to average 1 hour per response, including the time for reviewing instructions, searching existing data sources, gathering and maintaining the data needed, and completing and reviewing the collection of information. Send comments regarding this burden estimate or any other aspect of this collection of information, including suggestions for reducing this burden, to Washington Headquarters Services, Directorate for Information Operations and Reports, 1215 Jefferson Davis Highway, Suite 1204, Arlington, VA 22202-4302, and to the Office of Management and Budget, Paperwork Reduction Project (0704-0188), Washington, DC 20503.

1. AGENCY USE ONLY (Leave blank)		2. REPORT DATE May 1994	3. REPORT TYPE AND DATES COVERED Final - Proceedings (VOL 22, No. 4)	
4. TITLE AND SUBTITLE Symposium on Blood Substitutes: New Frontiers			5. FUNDING NUMBERS DAMD17-93-J-3024	
6. AUTHOR(S) Robert M. Winslow, M.D.				
7. PERFORMING ORGANIZATION NAME(S) AND ADDRESS(ES) University of California, San Diego San Diego, California 92161			8. PERFORMING ORGANIZATION REPORT NUMBER	
9. SPONSORING/MONITORING AGENCY NAME(S) AND ADDRESS(ES) U.S. Army Medical Research and Materiel Command Fort Detrick, Maryland 21702-5012			10. SPONSORING/MONITORING AGENCY REPORT NUMBER	
11. SUPPLEMENTARY NOTES				
12a. DISTRIBUTION/AVAILABILITY STATEMENT Approved for public release; distribution unlimited			12b. DISTRIBUTION CODE	
13. ABSTRACT (Maximum 200 words)				
14. SUBJECT TERMS			15. NUMBER OF PAGES	
			16. PRICE CODE	
17. SECURITY CLASSIFICATION OF REPORT Unclassified		18. SECURITY CLASSIFICATION OF THIS PAGE Unclassified	19. SECURITY CLASSIFICATION OF ABSTRACT Unclassified	20. LIMITATION OF ABSTR Unlimited

GENERAL INSTRUCTIONS FOR COMPLETING SF 298

The Report Documentation Page (RDP) is used in announcing and cataloging reports. It is important that this information be consistent with the rest of the report, particularly the cover and title page. Instructions for filling in each block of the form follow. It is important to *stay within the lines* to meet optical scanning requirements.

Block 1. Agency Use Only (Leave blank).

Block 2. Report Date. Full publication date including day, month, and year, if available (e.g. 1 Jan 88). Must cite at least the year.

Block 3. Type of Report and Dates Covered. State whether report is interim, final, etc. If applicable, enter inclusive report dates (e.g. 10 Jun 87 - 30 Jun 88).

Block 4. Title and Subtitle. A title is taken from the part of the report that provides the most meaningful and complete information. When a report is prepared in more than one volume, repeat the primary title, add volume number, and include subtitle for the specific volume. On classified documents enter the true classification in parentheses.

Block 5. Funding Numbers. To include contract and grant numbers; may include program element number(s), project number(s), task number(s), and work unit number(s). Use the following labels:

C - Contract	PR - Project
G - Grant	TA - Task
PE - Program Element	WU - Work Unit Accession No.

Block 6. Author(s). Name(s) of person(s) responsible for writing the report, performing the research, or credited with the content of the report. If editor or compiler, this should follow the name(s).

Block 7. Performing Organization Name(s) and Address(es). Self-explanatory.

Block 8. Performing Organization Report Number. Enter the unique alphanumeric report number(s) assigned by the organization performing the report.

Block 9. Sponsoring/Monitoring Agency Name(s) and Address(es). Self-explanatory.

Block 10. Sponsoring/Monitoring Agency Report Number. (If known)

Block 11. Supplementary Notes. Enter information not included elsewhere such as: Prepared in cooperation with...; Trans. of...; To be published in.... When a report is revised, include a statement whether the new report supersedes or supplements the older report.

Block 12a. Distribution/Availability Statement. Denotes public availability or limitations. Cite any availability to the public. Enter additional limitations or special markings in all capitals (e.g. NOFORN, REL, ITAR).

DOD - See DoDD 5230.24, "Distribution Statements on Technical Documents."

DOE - See authorities.

NASA - See Handbook NHB 2200.2.

NTIS - Leave blank.

Block 12b. Distribution Code.

DOE - Leave blank.

DOE - Enter DOE distribution categories from the Standard Distribution for Unclassified Scientific and Technical Reports.

NASA - Leave blank.

NTIS - Leave blank.

Block 13. Abstract. Include a brief (*Maximum 200 words*) factual summary of the most significant information contained in the report.

Block 14. Subject Terms. Keywords or phrases identifying major subjects in the report.

Block 15. Number of Pages. Enter the total number of pages.

Block 16. Price Code. Enter appropriate price code (*NTIS only*).

Blocks 17 - 19. Security Classifications. Self-explanatory. Enter U.S. Security Classification in accordance with U.S. Security Regulations (i.e., UNCLASSIFIED). If form contains classified information, stamp classification on the top and bottom of the page.

Block 20. Limitation of Abstract. This block must be completed to assign a limitation to the abstract. Enter either UL (unlimited) or SAR (same as report). An entry in this block is necessary if the abstract is to be limited. If blank, the abstract is assumed to be unlimited.

Artificial Cells, Blood Substitutes, and Immobilization Biotechnology

Editor-In-Chief: THOMAS M. S. CHANG, O.C., M.D., Ph.D., FRCP(C),
Director, Artificial Cells and Organs Research Centre,
Professor of Physiology, Medicine and Biomedical
Engineering, Associate of Chemical Engineering and
Chemistry, McGill University, 3655 Drummond St.,
Montreal, P.Q., Canada H3G 1Y6

Associate
Editors:

ROBERT S. LANGER, Sc.D., *Professor, Chemical and*
Biomedical Engineering, Massachusetts Institute of
Technology, Cambridge, Massachusetts, USA
EISHUN TSUCHIDA, Ph.D., *Professor, Department of*
Chemistry, Waseda University, Tokyo, Japan
ROBERT M. WINSLOW, M.D., *Professor, Department*
of Medicine, University of California at San Diego,
California, USA
YAO-TING YU, Ph.D., *Director, Institute for Molecular*
Biology, Nankai University, Tianjin, People's Republic of
China

Assistant
Editors:

T. NISHIYA, Ph.D., *Assistant Professor*
R. SIPEHIA, Ph.D., *Assistant Professor*
Artificial Cells and Organs Research Centre, McGill
University, Montreal, Quebec, Canada

Editorial Board

T. AGISHI, *Tokyo Women's Medical College, Tokyo, Japan*
K. ATSUMI, *University of Tokyo, Tokyo, Japan*
R. H. BARLETT, *University of Michigan, Ann Arbor, Michigan*
P.E. BARRE, *Royal Victoria Hospital, Montreal, Quebec, Canada*
V. BONOMINI, *St. Orsola University Hospital, Bologna, Italy*
G. BRUNNER, *Medizinische Hochschule, Hannover, Germany*
A. S. CHAWLA, *Bureau of Medical Devices, Ottawa, Ontario, Canada*
R.C.-J. CHIU, *Montreal General Hospital, Montreal, Quebec, Canada*

(continued)

**ARTIFICIAL CELLS, BLOOD SUBSTITUTES, AND
IMMOBILIZATION BIOTECHNOLOGY**

Editorial Board (continued)

- M. M. DEBAKEY, *Baylor College of Medicine, Houston, Texas*
V. DIXIT, *University of California, Los Angeles, California*
D. FALKENHAGEN, *Universitat Rostock, Rostock, Germany*
E. FRIEDMAN, *Downstate University Medical Center, Brooklyn, New York*
J.-L. FUNCK-BRENTANO, *Hopital Necker, Paris, France*
G. GREENBURG, *Brown University, Providence, Rhode Island*
G. GREGORIADIS, *University of London, London, England*
J. GRUNWALD, *The Israel Institute for Biological Research, Ness-Ziona,
Israel*
R. G. GUIDOIN, *Laval University, Quebec City, Quebec, Canada*
G. GUILBAULT, *University of New Orleans, New Orleans, Louisiana*
H. J. GURLAND, *Ludwig-Maximilians-Universitat Munchen, Munchen,
Germany*
B. L. HE, *Nankai University, Nankai, People's Republic of China*
J. HELLER, *Stanford Research Institute, Menlo Park, California*
A. S. HOFFMAN, *University of Washington, Seattle, Washington*
M. HORI, *University of Tsukuba, Tsukuba Ideopolis, Japan*
Y. KALAL, *Czechoslovak Academy of Sciences, Prague*
A. KANTROWITZ, *Sinai Hospital of Detroit, Detroit, Michigan*
M. KAYE, *Montreal General Hospital, Montreal, Quebec*
P. KEIPERT, *Alliance Pharmaceutical Corp., San Diego, California*
H. KLINKMAN, *Universitat Rostock, Rostock, Germany*
W. J. KOLFF, *College of Medicine, Salt Lake City, Utah*
T. KONDO, *Science University of Tokyo, Tokyo, Japan*
M. LOTAN, *Technion-Israel Institute of Technology, Technion City, Haifa,
Israel*
P. S. MALCHESKY, *Cleveland Clinic Foundation, Cleveland, Ohio*
G. MOSS, *Michael Reese Hospital, Chicago, Illinois*
V. NICOLAEV, *Academy of Sciences of the Ukrainian SSR, Ukraine*
Y. NOSE, *Cleveland Clinic, Cleveland, Ohio*
M. ODAKA, *Chiba University School of Medicine, Inohana, Chiba, Japan*
K. OTA, *Tokyo Women's Medical College, Tokyo, Japan*
E. PISKIN, *Hacettepe University, Ankara, Turkey*
M. POZNANSKY, *University of Western Ontario, Kingston, Canada*
G. REACH, *INSERM, Paris, France*
S. M. G. RINGOIR, *University of Ghent, Ghent, Belgium*
G. E. SCHREINER, *Georgetown University School of Medicine, Washington,
D.C.*

(continued)

**ARTIFICIAL CELLS, BLOOD SUBSTITUTES, AND
IMMOBILIZATION BIOTECHNOLOGY**

Editorial Board (continued)

- M. V. SEFTON, *University of Toronto, Toronto, Ontario, Canada*
 S. SEKIGUCHI, *Hokkaido Red Cross Blood Center, Sapporo, Japan*
 J. F. SHACKELFORD, *University of California, Davis, California*
 C. P. SHARMA, *Institute for Medical Sciences & Technology, India*
 S. SIDEMAN, *Technion-Israel Institute of Technology, Technion City, Haifa, Israel*
 G. SPLENDIANI, *University of Rome—Columbus, Rome, Italy*
 A. M. SUN, *Connaught Research Institute, Willowdale, Ontario, Canada*
 A. TREVINO-BECERRA, *Co. Veronica Anzures, Mexico*
 R. VALERI, *Boston University, Boston, Massachusetts*
 H. WEETALL, *CIBA-Corning Diagnostics, Merfield, Massachusetts*
 R. WILLIAMS, *King's College Hospital, London, England*
 J. F. WINCHESTER, *Georgetown University Hospital, Washington, D.C.*

Accession For	
NTIS CRA&I	<input checked="" type="checkbox"/>
DTIC TAB	<input type="checkbox"/>
Unannounced	<input type="checkbox"/>
Justification _____	
By _____	
Distribution /	
Availability Codes	
Dist	Avail and/or Special
A-1	

ARTIFICIAL CELLS, BLOOD SUBSTITUTES, AND IMMOBILIZATION BIOTECHNOLOGY

Indexing and Abstracting Services. Articles published in *Artificial Cells, Blood Substitutes, and Immobilization Biotechnology* are selectively indexed or abstracted in:

■ Abstracts Journal of the Institute of Scientific Information of the Russian Academy of Sciences ■ ASCA ■ Biomedical Engineering Citation Index ■ BioSciences Information Service of Biological Abstracts (BIOSIS) ■ Chemical Abstracts ■ Computer and Control Abstracts ■ Current Contents/Clinical Medicine ■ Current Contents/Life Sciences ■ Current Opinion in Gastroenterology ■ Current Papers in Computer and Control ■ Current Papers in Electrical and Electronic Engineering ■ Dental Abstracts ■ Electrical and Electronics Abstracts ■ Energy Data Base ■ Engineering Index ■ Excerpta Medica ■ Index Medicus ■ Index to Dental Literature ■ ISI/BIOMED ■ Materials Science Citation Index ■ Oral Research Abstracts ■ PASCAL ■ Physikalische Berichte ■ Reference Update ■ Research Alert ■ Science Citation Index ■ SciSearch

Manuscript Preparation and Submission. See end of issue.

Copyright © 1994 by Marcel Dekker, Inc. All rights reserved. Neither this work nor any part may be reproduced or transmitted in any form or by any means, electronic or mechanical, microfilming and recording, or by any information storage and retrieval systems without permission in writing from the publisher.

The Journals of Marcel Dekker, Inc. are available in microform from: RESEARCH PUBLICATIONS, 12 Lunar Drive, Drawer AB, Woodbridge, Connecticut, 06525, (203) 397-2600 or Toll Free 1-800-REACH-RP (732-2477). Outside North and South America: P.O. Box 45, Reading, RG18HF, England, 0734-583247.

Authorization to photocopy items for internal or personal use, or the internal or personal use of specific clients, is granted by Marcel Dekker, Inc., for users registered with the Copyright Clearance Center (CCC) Transactional Reporting Service, provided that the base fee is paid directly to CCC, 222 Rosewood Drive, Danvers, MA 01923. For those organizations that have been granted a photocopy license by CCC, a separate system of payment has been arranged.

Effective with Volume 14, Numbers 1&2, this journal is printed on acid-free paper.

Membership Application

**INTERNATIONAL SOCIETY FOR
ARTIFICIAL CELLS, BLOOD SUBSTITUTES,
AND IMMOBILIZATION BIOTECHNOLOGY
(ISABI)**

*Members of ISABI can subscribe to the popular journal
Artificial Cells, Blood Substitutes, and Immobilization
Biotechnology: An International Journal for only \$50.00!
See back of application for details.*

Join Today!

Application for: Full Membership
 Associate Membership

(Associate membership does not require publications.)

NAME: _____

ADDRESS: _____

CITY/STATE/ZIP: _____

COUNTRY: _____

TELEPHONE: _____

FAX: _____

application continues on back ►

Membership Application (cont.)

Present Position, Appointments, etc.:

Degree(s) (year, university, country):

Publications (please give total numbers): Please give complete references of 1-3 representative papers, presentations, or reports. (For Full Membership only.)

Please send this membership form (a photocopy is acceptable) to:

*Professor T. M. S. Chang
Director, Artificial Cells & Organs Research Centre
Faculty of Medicine, McGill University
3655 Drummond Street
Montreal, P.Q., Canada H3G 1Y6*

*If you would like to receive the journal **Artificial Cells, Blood Substitutes, and Immobilization Biotechnology** (5 issues), please subscribe directly to the publisher by sending a check for US \$50.00 made payable to "Marcel Dekker, Inc." plus a copy of this application to the address below. Send to:*

*Promotion Department
Marcel Dekker, Inc.
270 Madison Avenue
New York, NY 10016*

**BLOOD SUBSTITUTES AND
RELATED PRODUCTS:
THE FLUOROCARBON APPROACH**

Third of 3 Special Issues (Peer Reviewed) from
Vth International Symposium on Blood Substitutes
San Diego, California, USA
March 17-20, 1993

Guest Editor

Jean G. Riess, Ph.D
Université de Nice-Sophia Antipolis
Nice, Cedex 2, France

This is a special issue of *Artificial Cells, Blood Substitutes,
and Immobilization Biotechnology*, Volume 22, Number 4, 1994
and is continued from Volume 22, Number 2
and Number 3, 1994.

MARCEL DEKKER, INC. New York, Basel, Hong Kong

**ARTIFICIAL CELLS, BLOOD SUBSTITUTES, AND
IMMOBILIZATION BIOTECHNOLOGY**

Volume 22, Number 4, 1994

**Third of 3 Special Issues from
Vth International Symposium on Blood Substitutes
San Diego, California, USA
March 17-20, 1993**

CONTENTS

**Membership Application Form for the International
Society for Artificial Cells, Blood Substitutes, and
Immobilization Biotechnology (ISABI) v**

Editorial xvii

**BLOOD SUBSTITUTES AND RELATED PRODUCTS:
THE FLUOROCARBON APPROACH**

I. LECTURES

Difficulties in Demonstrating Efficacy of Blood Substitutes 945
T. F. Zuck

**Perfluorocarbons as Blood Substitutes: The Early Years.
Experience with Fluosol DA-20% in the 1980s 955**
*R. K. Spence, E. D. Norcross, J. Costabile, S. McCoy,
A. C. Cernaianu, J. B. Alexander, M. J. Pello, U. Atabek,
and R. C. Camishion*

**Improvement in Circulatory and Oxygenation Status by
Perflubron Emulsion (Oxygent™ HT) in a Canine Model of
Surgical Hemodilution 965**
*A. C. Cernaianu, R. K. Spence, T. V. Vassilidze,
J. G. Gallucci, T. Gaprindashvili, A. Olah, R. L. Weiss,
J. H. Cilley, Jr., P. E. Keipert, N. S. Faithfull, and
A. J. DelRossi*

**Use of Current Generation Perfluorocarbon Emulsions
in Cardiac Surgery 979**
*W. L. Holman, D. C. McGiffin, W. V. A. Vicente,
R. D. Spruell, and A. D. Pacifico*

Fluorocarbon Emulsions—The Stability Issue	991
<i>M. Postel, J. G. Riess, and J. G. Weers</i>	
Microemulsions of Perfluorinated and Semi-fluorinated Compounds	1007
<i>A. Lattes and I. Rico-Lattes</i>	
Fluorocarbon Blood Substitutes in Russia	1019
<i>V. V. Obratsov</i>	
Quantitative pO₂ Imaging <i>In Vivo</i> with Perfluorocarbon F-19 NMR: Tracking Oxygen from the Airway Through the Blood to Organ Tissues	1029
<i>S. R. Thomas, R. W. Millard, R. G. Pratt, Y. Shiferaw, and R. C. Samaratunga</i>	
Pharmacokinetics and Side Effects of Perfluorocarbon- Based Blood Substitutes	1043
<i>S. F. Flaim</i>	
Functional MR Imaging of a Metabolite of ¹⁷O₂	1055
<i>S. E. Lasker</i>	
Cardiovascular Applications of Fluorocarbons in Regional Ischemia/Reperfusion	1069
<i>R. A. Kloner and S. Hale</i>	
Cardiovascular Applications of Fluorocarbons: Current Status and Future Direction—A Critical Clinical Appraisal	1083
<i>J. D. Ogilby</i>	
Perfluorochemical Emulsions and Radiation Therapy	1097
<i>S. Rockwell</i>	
Combination of Perfluorochemical Emulsions and Carbogen Breathing with Cancer Chemotherapy	1109
<i>B. A. Teicher</i>	
Full-Tidal Liquid Ventilation with Perfluorocarbon for Prevention of Lung Injury in Newborn Non-human Primates	1121
<i>J. C. Jackson, T. A. Standaert, W. E. Truog, and W. A. Hodson</i>	
Perfluorocarbon Associated Gas Exchange (PAGE): Gas Ventilation of the Perfluorocarbon Filled Lung	1133
<i>B. P. Fuhrman, L. J. Hernan, B. A. Holm, C. L. Leach, M. C. Papo, and D. M. Steinhorn</i>	

CONTENTS

xi

Non-invasive Physiology: ¹⁹F NMR of Perfluorocarbons 1141
R. P. Mason

II. POSTERS

Pharmacokinetics and Tolerance of Weekly Oxygent™ CA
Infusions in the Dog 1155
*C. J. Henry, W. G. Brewer, Jr., R. A. Henderson, and
W. R. Brawner*

Enhanced Oxygen Delivery by Perflubron Emulsion During
Acute Hemodilution 1161
*P. E. Keipert, N. S. Faithfull, J. D. Bradley,
D. Y. Hazard, J. Hogan, M. S. Levisetti, and R. M. Peters*

Influence of Perflubron Emulsion Particle Size on Blood
Half-Life and Febrile Response in Rats 1169
*P. E. Keipert, S. Otto, S. F. Flaim, J. G. Weers,
E. A. Schutt, T. J. Pelura, D. H. Klein, and
T. L. Yaksh*

Room Temperature Stable Perfluorocarbon Emulsions with
Acceptable Half-Lives in the Reticuloendothelial
System 1175
*J. G. Weers, J. Liu, T. Fields, P. Resch, J. Cavin,
and R. A. Arlauskas*

Improved Control over Particle Sizes and Stability of
Concentrated Fluorocarbon Emulsions by Using Mixed
Fluorocarbon/Hydrocarbon Molecular Dowels 1183
C. Cornélus, M. P. Krafft, and J. G. Riess

Biodistribution and Excretion of a Mixed Fluorocarbon-
Hydrocarbon "Dowel" Emulsion as Determined by ¹⁹F NMR 1193
*L. Zarif, M. Postel, L. Trevino, J. G. Riess, A. Valla,
and R. Follana*

Pulmonary Gas Trapping Differences Among Animal Species
in Response to Intravenous Infusion of Perfluorocarbon
Emulsions 1199
*T. Leakakos, E. G. Schutt, J. C. Cavin, D. Smith,
J. D. Bradley, C. A. Strnat, U. del Balzo, D. Y. Hazard,
S. Otto, T. K. Fields, P. E. Keipert, D. H. Klein, and
S. F. Flaim*

Proposed Mechanism of Pulmonary Gas Trapping (PGT) Following Intravenous Perfluorocarbon Emulsion Administration	1205
<i>E. Schutt, P. Barber, T. Fields, S. Flaim, J. Horodniak, P. Keipert, R. Kinner, L. Kornbrust, T. Leakakos, T. Pelura, J. Weers, R. Houmes, and B. Lachmann</i>	
Phagocytosis of a Fluorescently Labeled Perflubron Emulsion by a Human Monocyte Cell Line	1215
<i>D. J. Smith, E. S. Kornbrust, and T. A. Lane</i>	
Influence of Perflubron on the Creation of Oxygen Free Radical Products in Mesenteric Artery Occlusion Shock	1223
<i>A. J. Augustin and J. Lutz</i>	
Perfluorodecalin Emulsion Tested for Biocompatibility in Macrophages by Means of a Magnetometric Method	1231
<i>M. Koester, J. Lutz, A. J. Augustin, and H. Meinert</i>	
The Effect of Moderate Hemodilution with Fluosol® on Cytochrome P4502D6 Activity in the Rat	1237
<i>R. P. Shrewsbury, S. R. Oliver, and L. G. White</i>	
Perfluorocarbon Distribution to Liver, Lung, and Spleen of Emulsions of Perfluorotributylamine (FTBA) in Pigs and Rats and Perfluorooctyl Bromide (PFOB) in Rats and Dogs by ¹⁹F NMR Spectroscopy	1243
<i>A. J. McGoron, R. Pratt, J. Zhang, Y. Shiferaw, S. Thomas, and R. Millard</i>	
Lung Functions After Intravenous or Intraperitoneal Administration of Perfluorooctyl Bromide (PFOB) or Perfluorotributylamine (FTBA) Emulsions	1251
<i>R. W. Millard and A. J. McGoron</i>	
Effect of Perfluorochemicals on Liver Detoxication Enzymes	1259
<i>V. V. Obratsov and D. G. Shekhtman</i>	
Mixed Fluorocarbon/Hydrocarbon Molecular Dowels Help Protect Concentrated Fluorocarbon Emulsions with Large Size Droplets Against Coalescence	1267
<i>C. Cornélus, M. P. Krafft, and J. G. Riess</i>	

CONTENTS

xiii

- Amphiphilic Sugar Phosphates with Single or Double Perfluoroalkylated Hydrophobic Chains for Use in Oxygen and Drug Delivery Systems** 1273
F. Guillod, J. Greiner, A. Milius, and J. G. Riess
- The Elimination Peculiarities of Perfluorocarbon Emulsions Stabilized with Egg Yolk Phospholipid** 1281
T. K. Putyatina, U. D. Aprosin, and N. I. Afonin
- Oxidative Assessment of Phospholipid-Stabilized Perfluorocarbon-Based Blood Substitutes** 1287
T. E. Tarara, S. H. Malinoff, and T. J. Pelura
- Effect of Perfluorochemical Emulsion on Lipoproteins of Plasma Blood** 1295
N. N. Doronina, O. A. Kurmacheva, and N. I. Afonin
- Effects of Buffer pH and Phosphate Concentration on the Droplet Size and EYP Hydrolysis of Perflubron/EYP Emulsions** 1299
D. Song, T. J. Pelura, J. Liu, and Y. Ni
- Effects of Formulation, Processing, and Storage Parameters on the Characteristics and Stability of Perflubron Emulsion** 1307
Y. Ni, T. J. Pelura, T. A. Sklenar, R. A. Kinner, and D. Song
- Analysis of Ostwald Ripening in Fluorocarbon Emulsions by Sedimentation Field-Flow Fractionation** 1317
R. A. Arlauskas, D. H. Klein, and J. G. Weers
- Concentrated Emulsions of Perflubron in Aqueous Media** 1325
S. S. Habif, H. L. Rosano, and C. B. Oleksiak
- Application of Fluorocarbon Emulsions as Components of Cosmetics and Medical Ointments** 1331
O. E. Oxynoid, D. P. Sydliarov, Yu. D. Aprosin, and V. V. Obrastsov
- Effect of Lipid Absorption by Perfluorochemical Emulsions in the Bloodstream and Perspectives of Its Clinical Application** 1337
E. V. Tereshina and N. I. Afonin

Central Hemodynamics and Blood Flow Distribution During Infusion of Perflubron Emulsion or Its Vehicle: Effects in Anesthetized Dogs	1343
<i>G. P. Biro</i>	
Tumor Oxygenation After 1) Carbogen and/or Perflubron Emulsion Administration in Tumor Xenografts 2) Carbogen Administration in Patients	1355
<i>M. Guichard, E. Lartigau, L. Martin, C. Thomas, P. Weeger, P. Lambin, A. M. Le Ridant, A. Lusinchi, P. Wibault, B. Luboinski, and F. Eschwege</i>	
Tumor Oxygen Tension: Measurement Using Oxygent™ as a ¹⁹F NMR Probe at 4.7 T	1361
<i>R. P. Mason and P. P. Antich</i>	
Oxygenation of Human Tumor Xenografts in Nude Mice by a Perfluorochemical Emulsion and Carbogen Breathing	1369
<i>B. A. Teicher, G. N. Schwartz, N. P. Dupuis, T. Kusomoto, M. Liu, F. Liu, and D. Northey</i>	
Oxygenation During Perfluorocarbon Associated Gas Exchange in Normal and Abnormal Lungs	1377
<i>L. J. Hernan, B. P. Fuhrman, M. C. Papo, C. L. Leach, A. E. Thompson, F. D. Nesti, N. Salman, D. M. Steinhorn, W. Novotny, P. Paczan, B. Burak, and M. Rath</i>	
Long-Term Partial Liquid Ventilation (PLV) with Perflubron in the Near-Term Baboon Neonate	1381
<i>K. M. Sekins, J. J. Coalson, R. A. deLemos, T. K. Fields, S. F. Flaim, J. M. Guerra, R. M. Hopkins, J. C. Jackson, D. M. Null, and D. C. Winter</i>	
Lung Management with Perfluorocarbon Liquid Ventilation Improves Pulmonary Function and Gas Exchange During Extracorporeal Membrane Oxygenation (ECMO)	1389
<i>R. B. Hirschl, A. Parent, R. Tooley, T. Shaffer, M. Wolfson, and R. H. Bartlett</i>	
Neonatal Endotracheal Tubes: Variation in Airway Resistance with Different Perfluorochemical Liquids	1397
<i>W. W. Fox, C. Cox, C. Weis, M. R. Wolfson, and T. H. Shaffer</i>	

CONTENTS

xv

Fluorinated Phospholipid-Based Vesicles as Potential Drug Carriers: Encapsulation/Sustaining of Drugs and Stability in Human Serum 1403
F. Frezard, C. Santaella, P. Vierling, and J. G. Riess

Utility of a Perfluorochemical Liquid for Pulmonary Diagnostic Imaging 1409
M. R. Wolfson, R. G. Stern, N. Kechner, K. M. Sekins, and T. H. Shaffer

Novel Injectable Fluorinated Contrast Agents with Enhanced Radiopacity 1421
V. Sanchez, L. Zarif, J. Greiner, J. G. Riess, S. Cippolini, and J. N. Bruneton

Preclinical and Clinical Studies on Lymph Node Imaging Using Perflubron Emulsion 1429
G. Hanna, D. Saewert, J. Shorr, K. Flaim, P. Leese, M. Kopperman, and G. Wolf

Intracellular and Extracellular Transport of Perfluorocarbon Emulsion from Subcutaneous Tissue to Regional Lymphatics 1441
F. Ikomi, G. Hanna, and G. W. Schmid-Schönbein

Monitoring of pO₂ by Spin-Spin Relaxation Rate 1/T₂ of ¹⁹F in a Rabbit Abscess Model 1449
Q. Guo, R. F. Mattrey, C. Guclu, R. B. Buxton, and O. Nalcioglu

Normothermic Preservation of "Multiple Organ Blocks" with a New Perfluorooctyl Bromide Emulsion 1455
E. J. Voiglio, L. Zarif, F. Gorry, M. P. Krafft, J. Margonari, J. M. Dubernard, and J. G. Riess

Organ Preservation Without Extreme Hypothermia Using an Oxygent™ Supplemented Perfusate 1463
L. Brasile, P. DelVecchio, K. Amyot, C. Haisch, and J. Clarke

Postmortem Organ Salvage Using an Oxygent™ Supplemented Perfusate 1469
L. Brasile, P. DelVecchio, U. Rudofsky, C. Haisch, and J. Clarke

Reducing Magnetic Susceptibility Differences Using Liquid Fluorocarbon Pads (Sat Pad™): Results with Spectral Presaturation of Fat	1477
<i>S. S. Eilenberg, V. M. Tartar, and R. F. Mattrey</i>	
Double-Tailed Perfluoroalkylated Glycolipids as Components for Drug Delivery and Targeting Systems. Preliminary Biocompatibility Results	1485
<i>L. Zarif, J. G. Riess, B. Pucci, C. Guedj, and A. A. Pavia</i>	
Efficacy of Imagent® BP at 1.5 ml/kg in a Rabbit Liver Tumor Model	1491
<i>K. G. Baker, R. Wrigley, H. B. Saunders, and R. F. Mattrey</i>	
The Use of Imagent® BP as a Blood Pool Contrast Agent to Visualize and Quantitate Liver Tumor Burden	1501
<i>G. C. Steinbach, K. G. Baker, G. L. Lim, R. F. Mattrey, and R. S. Arellano</i>	
Characterization and Mechanism of Side-Effects of Oxygent™HT (Highly Concentrated Fluorocarbon Emulsion) in Swine	1511
<i>S. F. Flaim, D. R. Hazard, J. Hogan, and R. M. Peters</i>	
Forthcoming Meetings	1517

EDITORIAL

Twenty two invited lectures and eighty posters: the crop of high quality results presented at the Vth International Symposium on Blood Substitutes in San Diego on the use of fluorocarbons for *in vivo* oxygen transport and other potential biomedical applications was impressive. Progress was reported in the formulation and development of injectable fluorocarbon emulsions, in the knowledge of their structure and physical and biological characteristics, in defining the appropriate conditions of use for optimal benefit, in the understanding of their pharmacokinetics and control of their side-effects, and in the development of new models for their evaluation. Large-scale production of heat-sterilizable, fluid, stable, ready-for-use fluorocarbon emulsions of diverse concentrations is now feasible. New data have been produced to support efficacy of such emulsions as temporary substitutes for red blood cells, as antihypoxic agents in general, or as contrast agents for diagnosis. Animal and human data indicate that such emulsions are safe for use at clinically relevant doses. The transient side-effects observed are believed to be generic to uptake of particles by the reticuloendothelial system and are largely relieved by steroids and cyclooxygenase inhibitors.

As oxygen carriers, these emulsions are designed primarily to prevent, reduce or suppress temporary tissue hypoxia. Injected perfluorocarbon emulsions essentially increase the oxygen-carrying capacity of the plasma compartment. They will reach maximum effectiveness in patients with low hemoglobin when inspired oxygen partial pressure and cardiac output are high; these are, in particular, the conditions encountered when perioperative normovolemic hemodilution is practiced. Fluorocarbon emulsions are therefore expected to play a major role in surgery by providing an increased margin of safety and a reduction in donated blood transfusion when used in conjunction with blood conservation strategies.

There nevertheless remains much work to be done to increase our fundamental understanding about the physiology of oxygen transport by

fluorocarbon emulsions and the toxicity of certain formulations. We need to prolong intravascular persistence and further minimize side effects by making particles that evade the RES, optimally adapt emulsion characteristics to specific applications, pursue further clinical evaluation, and collect the efficacy and safety data needed for obtaining regulatory approval. Perioperative hemodilution appears to be an ideal model for the latter purpose.

The potential applications of fluorocarbons in medicine have been elucidated further. A wealth of data was presented on the use of fluorocarbon emulsions for rescuing ischemic tissues, in cardiovascular bypass surgery, as cardioplegic or reperfusion solutions, as an adjuvant to PTCA, for improving tumor response to radio- or chemotherapy, for the normothermic preservation of organs, etc. When used as contrast agents, appropriately formulated fluorocarbon emulsions were shown to provide contrast in x-ray tomography and ultrasound. ^{19}F NMR was used to evaluate tissue oxygenation. Neat fluorocarbons were investigated for liquid ventilation as a treatment for respiratory distress syndrome. One fluorocarbon has been approved as an oral contrast agent for delineating the GI tract by MRI. Other highly fluorinated materials, including vesicles and gels, may show promise in drug targeting and delivery. The dynamism and inventiveness of the research teams represented in San Diego encourage us to anticipate further developments and decisive results within the foreseeable future.

According to many comments, the Symposium was successful and has advanced our common aims. It was also a splendid opportunity to get together, exchange ideas and information, and plan collaborative research. We must always remember that lack of communication is the major impediment to progress in science. We hope that this volume of Proceedings, each paper of which has been thoroughly refereed and revised, will also prove useful to all those who are involved in the challenge of developing satisfactory oxygen carriers and related products. Finally I wish again to thank heartily both the "behind the scenes" contributors and the individuals who traveled from near and far to make this meeting a productive and convivial event.

Jean G. Riess

I. LECTURES

**DIFFICULTIES IN DEMONSTRATING EFFICACY OF
BLOOD SUBSTITUTES**

Thomas F. Zuck, M.D.
Hoxworth Blood Center of the University of Cincinnati
Cincinnati, Ohio

ABSTRACT

Currently, the fear of infectious disease transmission by allogenic blood transfusions has spurred interest in developing a blood substitute. FDA approval requires that a sponsor demonstrate that the substitute is effective. The challenge in designing efficacy studies in man is proving that the substitute offers significant advantages over conventional therapies for acute blood loss. This task is complicated by the oxygen reserve and the response to hemodilution following treatment of acute blood loss in man. Paradoxically, the technique that relies on these protective physiologies--isovolemic perioperative hemodilution--may offer the best experimental model to establish efficacy of a blood substitute in man.

INTRODUCTION

The emergence of the acquired immunodeficiency syndrome (AIDS) has enhanced public awareness of the many risks of allogeneic blood transfusions. Both physicians and their patients are aggressively seeking alternatives to transfusions and practices in transfusion medicine are changing. Use of autologous transfusions, in their several variations, continues to increase by patients requiring elective surgery. However, not all elective surgery patients are suitable candidates for so-called predeposit autologous transfusions. Physicians also continue to lower red

cell "transfusion triggers"--those clinical and laboratory points at which they prescribe transfusions. But, an optimal hemoglobin concentration has not been established[1] and evidence is emerging that physicians may have become overly zealous in avoiding red cell transfusions in the perioperative period.[2,3] Despite the many efforts to avoid blood transfusions, the environment of fear regarding them remains and has invigorated efforts to develop blood substitutes, both in the public and private sectors. The public understands very well that trauma patients have no alternatives to allogenic transfusions.

The term "blood substitute" is a misnomer because current formulations are designed to carry oxygen and carbon dioxide and perhaps provide oncotic pressure. None of the other metabolic, regulatory, and defensive attributes of blood are provided by these products. With this disclaimer in mind, two blood substitute candidates have emerged as preeminent: hemoglobin-based formulations and perfluorocarbon emulsions. Before either can be used clinically approval as a drug or licensure as a biological by the Food and Drug Administration (FDA) is necessary. In order for either to be issued, a sponsor must demonstrate that their formulation is both safe and effective. Safety concerns relate principally to the toxicity profile of the proposed formulation. Both of the current candidates pose problems in this regard, but the nature of their problems differ somewhat. Efficacy must be established by clinical trials of the proposed formulation. Two aspects of the physiology of oxygen delivery in man pose difficulties in designing efficacy trials: the oxygen reserve and the response to acute hemodilution. Dose limitations may pose additional trial design problems.

DISCUSSION

Oxygen reserve in man

Man normally is protected by a significant excess oxygen-carrying capacity. Hemoglobin carries 1.36 cc of oxygen per gram. At a hemoglobin concentration of approximately 14 grams per dl, about 20 cc of oxygen are carried per 100 ml of blood. However, at basal state, only about 5 cc of oxygen are extracted by the

tissues. The difference between the oxygen extracted and that carried, approximately 75 percent by volume, is termed the "oxygen reserve." In an acute clinical setting, lowering the hemoglobin concentration from 14 to 11 grams per dl reduces the oxygen reserve by only 30 percent. Thus, at moderate levels of hemoglobin reduction, improvements in tissue oxygenation by replacing lost blood with a blood substitute, in contradistinction to a volume expander, are difficult to measure. The model widely used to demonstrate efficacy of blood substitutes in animals--exchange transfusions to very low hematocrits--is not applicable to study these formulations in man.

Response to acute hemodilution

Although other claims may be developed, for the purpose of this essay it is assumed that efficacy claims for blood substitutes will be to replace lost oxygen-carrying capacity due to acute blood loss. To substantiate this claim substitute formulations must be compared to standard resuscitation regimens in which acute blood loss is replaced by either colloid or crystalloid solutions. Thus, the response to acute hemodilution defines the design of efficacy trials.

As noted, at rest only about 25 percent of the oxygen carried by hemoglobin is off-loaded to the tissues, especially skeletal muscle. When oxygen demands increase as a result of exercise, the heart rate increases. At the same time, the stroke volume of the heart increases. Both of these mechanisms increase cardiac output. The oxygen extraction ratio of the heart when the body is at rest is higher than the rest of the body, that is, the coronary sinus PO_2 normally approaches the critical level. When the myocardial need for oxygen increases as a result of the greater heart work generated by increasing cardiac output, coronary vessels dilate to provide additional blood to the myocardium. Coronary artery disease may limit this response.

Following hemorrhage, little extravascular water is mobilized acutely to replace the lost intravascular volume and some hemoconcentration occurs. Replacement with crystalloid or colloid not only replaces lost volume, but the

resulting hemodilution improves overall cardiovascular performance. This effect is primarily due to a decrease in blood viscosity that results in an increased venous return to the heart and an increased stroke volume.[4] As long as normovolemia is maintained, the pulse will remain constant until the hematocrit drops below 25 percent. At hematocrits between 45 and 30 percent, cardiac output increases almost linearly as the hematocrit falls.[5] Some workers have suggested that an hematocrit of 30 percent is actually optimal in balancing fluidity with oxygen transport requirements.[6] At this hematocrit cardiac output increases up to 50 percent. Perioperative isovolemic hemodilution practice is tolerated, in part, due to this physiologic response to normovolemic lowering of the hemoglobin concentration. However, the safety and efficacy of hemodilution depend upon normal cardiovascular function. Thus, the advantages of hemodilution may not be gained in subjects with compromised coronary circulation.[7] Although conflicting animal data have been reported, blood flow is redistributed following acute hemodilution not only among organs, but within organs. For example, the fraction of cardiac output flowing to the kidney is reduced following hemodilution and blood is redistributed to the inner cortex.[8] These redistributions not only improve tolerance to acute blood loss, but make measurements of critical organ function and oxygenation difficult to interpret.

Validation of tolerance to acute blood loss

Numerous studies in animals and man have validated the significant tolerance to acute blood loss if intravascular volume has been maintained.

Animal studies Because of their clear relevance to combat casualty care, many of the published hypovolemic shock and resuscitation studies have been undertaken by military research teams. Traverso, et al. tested several resuscitation regimens in a conscious swine model.[9, 10] Anesthetized swine were instrumented by placing bleeding and treatment catheters and returned to their cages. Five days later, through the catheter previously placed in the distal aorta, the animals were hemorrhaged 70 percent of their estimated blood volume (54

ml/kg) in 13 to 17 minutes. Hematocrits of 9 to 12 percent were achieved and, left untreated, this regimen was usually fatal. Within 4 minutes, several replacement protocols were initiated, among them, 1:1 5 percent albumin, 3:1 Ringer's lactate, fresh-frozen human and porcine plasma, and porcine whole blood. Death within the first 24 hours served as the endpoint. The most striking, but predictable, finding was that fresh-frozen plasma was nearly as effective as whole blood in resuscitating the animals. Further, crystalloid and colloid solutions were nearly as effective as fresh-frozen plasma in reviving the animals and both solutions were similarly effective. Fresh-frozen plasma remained slightly superior.

Stable hemorrhagic models have been criticized because the bleeding did not continue as it does in most trauma until all vascular lesions have been controlled.[11] Studies in which a controlled aortic tear is part of the regimen have been claimed to mimic actual trauma settings more accurately and high-volume crystalloid administration use has been questioned.[12] Lower volumes of resuscitation solutions have been found to be more effective than the conventional volumes used by Traverso, et al.[13] These workers infused solutions until a predetermined mean arterial pressure (MAP) was reached. Survival of dogs was greater and blood loss reduced when they were infused to a lower MAP than when they were infused to a higher MAP. These findings further complicate the design of protocols to determine at what point and under what conditions resuscitation with a blood substitute would be superior to crystalloid or colloid alone.

Survival is a crude measure of efficacy. Using a more subtle swine model, Biro, et al, showed hemodilution to a hematocrit of 23 to 26 percent with an oxygen-carrying perfluorocarbon formulation (Fluosol DA) was not superior to a dextran solution in preserving myocardial integrity if the coronary circulation was uncompromised; however, if the left anterior descending coronary artery was occluded to 33 percent of normal, the perfluorochemical emulsion was superior.[14]

Studies in man Studies of perioperative or interoperative isovolemic hemodilution provide the best evidence in man that significant acute blood loss is tolerated well provided the patient remains normovolemic. This technique has been

used for many years, although not uniformly, throughout the world and its safety and efficacy appear established.[15-17] The extent of hemodilution is defined by the peripheral venous hematocrit. Using crystalloid, the maximum improvement in rheology as noted has been reported to occur at an hematocrit of 30 percent, although it may be somewhat higher if albumin is used for replacement.[18] This is in accord with the theoretical studies cited above. Most investigators believe that isovolemic hemodilution to hematocrits between 25 and 30 percent also are safe.[19]

Contrary views about the safety of hemodilution

Not all observers believe that the tolerance to lowered hemoglobin concentration offers the margin of safety frequently claimed. Kiel and coworkers found that gastric and intestinal oxygenation was affected adversely following hemodilution.[20] Lundsgaard-Hansen questioned the margin of safety on theoretical grounds, especially in the presence of compromised coronary circulation.[21] Critics of hemodilution argue that any reduction of oxygen reserves by lowering the oxygen-carrying capacity is dangerous. This view is reflected in Europe by the higher permissible levels of hemoglobin in predeposit programs than in the United States (11 g per dl).[22]

Viscosity and oncotic pressure as a problem in clinical trials

One of the more influential clinical trials of a blood substitute tested a perfluorocarbon emulsion (Fluosol-DA).[23] Because of the high viscosity of the formulation, the Claimed Exemption for a New Drug (IND) under which the study was done, limited infusions of Fluosol to 40 ml per kg. As a blood substitute, Fluosol was found to be "ineffective in severe anemia" in these trials, even though the number of patients studied was limited and their clinical condition extremely serious. Critics of these studies claim efficacy could not be proven because the dose was inadequate.[24] Hermoni, et al, similarly point out that it may have been the duration of therapy that failed, again limited by dose considerations, rather than the modality itself.[25]

Hemoglobin preparations exert oncotic pressure, the magnitude of which depends upon the formulation. Although no preparation of free tetrameric hemoglobin currently is advocated for clinical use, a solution of 7 grams per dl exerts an oncotic pressure of about 30 torr. Crosslinked preparations exert lightly lower pressures, but polymerized pyridoxilated hemoglobin still exerts a colloid oncotic pressure of about 30 torr at a concentration of 9 grams per dl.[26] Thus, the oncotic pressure effects of these modified hemoglobins can not be ignored in designing efficacy studies.

Prospects for efficacy trials

Although resuscitation of trauma patients is an extremely attractive application of blood substitutes, it is undertaken in such complex clinical settings that establishing efficacy of one particular resuscitation regimen compared with another may be extremely difficult. Further, obtaining informed consent to use experimental drugs in this setting is virtually impossible and surrogate consent is not permitted in some states. Paradoxically, although perioperative isovolemic hemodilution studies validate tolerance to reduced hematocrits, studies using this technique may hold the best prospect for establishing efficacy of blood substitutes. Patient monitoring during anesthesia is highly sophisticated and subtle differences, especially in gas transport and myocardial function, may be demonstrable. Hemodilution has been used as a model to establish efficacy of hemoglobin preparations in animals.[27]

Several efficacy end-points can be envisioned for these studies. First, improved cardiovascular performance may be demonstrated in patients hemodiluted with blood substitutes compared to those in which crystalloid was used. Improvement may be demonstrated in a subset of patients, such as those with severe cardiovascular compromise, especially in the coronary or cerebral vessels. Second, the need for return of the autologous blood delayed and the need for allogenic blood lessened. Hemodilution with a blood substitute would provide an additional margin of safety were these events observed. Either of these outcomes would establish efficacy of the study formulation.

REFERENCES

1. AJ Erslev, J Caro, SJ Schuster. Is there an optimal hemoglobin level? *Transfusion Med Rev* 3:237-42 (1989).
2. PD Mintz. Undertransfusion (editorial). *Am J Clin Path* 91:150-51 (1989).
3. R Christopherson, S Frank, E Norris, P Rock, S Gottlieb, C Beattie. Low postoperative hematocrit is associated with cardiac ischemia in high-risk patients (Abstract). *Anesthesiology* 75:A99 (1991).
4. AC Guyton, TQ Richardson. Effect of hematocrit on venous return. *Circulation Res* 9:157-64 (1961).
5. K Messmer. Compensatory mechanisms for acute dilutional anemia. *Bibliothca haemat* 47:31-42 (1981).
6. KFW Messmer. Acceptable hematocrit levels in surgical patients. *World J Surg* 11:41-6 (1987).
7. AS Geha, AE Baue. Graded coronary stenosis and coronary flow during acute normovolemic anemia. *World J Surg* 2:645-52 (1978).
8. DR Jobes, J Gallager. Acute normovolemic hemodilution. In, *Techniques of Transfusion*. Stehling L. (ed.) *International Anesthesia Clinics* 20:77-95 (1982).
9. LW Traverso, WF Lee, MJ Langford. Fluid resuscitation after an otherwise fatal hemorrhage. I. Crystalloid solutions. *J Trauma* 26:168-75 (1986).
10. LW Traverso, SJ Hollenbach, RB Bolin, MJ Langford, LR DeGuzman. Fluid resuscitation after an otherwise fatal hemorrhage. II. Colloid solutions. *J Trauma* 26:176-82 (1986).
11. WH Bickell, SP Bruttig, CE Wade. Hemodynamic response to abdominal aortotomy in anesthetized swine. *Circulatory Shock* 28:321-2 (1989).
12. WH Bickell, AP Bruttig, CE Wade, P Maningas, GA Millnamow. The detrimental effects of IV crystalloid after aortotomy in the swine (Abstract). *Ann Emerg Med* 18:476 (1989).
13. T Kowalenko, SA Stern, X Wang, S Dromen. Improved outcome with "hypotensive" resuscitation of uncontrolled hemorrhagic shock in a swine model (Abstract). *J Trauma* 31:1032 (1991).

14. GP Biro, EA Breisch, FC White, CM Bloor, BD Guth. The effect of hemodilution with fluorocarbon or dextran on regional myocardial flow and function during acute coronary stenosis in the pig. *Amer J Cardiovasc Pathol* 1:99-114 (1986).
15. H Laks, RN Pilon, WP Klovekorn, W Anderson, JR McCallum, NE O'Conner. Acute hemodilution: Its effect on hemodynamics and oxygen transport in anesthetized man. *Ann Surg* 180:103-8 (1974).
16. L Stehling, H Zauder. Acute normovolemic hemodilution. *Transfusion* 31:857-68 (1991).
17. RT Schaller Jr, J Schaller, EB Furman. The advantages of hemodilution anesthesia for major liver resection in children. *J Pediat Surg* 19:705-10 (1984).
18. E Lowenstein, P Hallowell: Hemodilution and fresh autologous blood transfusion in open heart surgery. In, *Autologous Transfusion*, Dawson RB (ed). Washington, American Association of Blood Banks, pp 73-93 (1976).
19. TF Zuck, PM Carey. Autologous transfusion practice. *Vox Sang* 58:234-53 (1990).
20. JW Kiel, GL Reidel, AP Shepherd. Effect of hemodilution on gastric and intestinal oxygenation. *Am J Physiol* 256:H171-78 (1989).
21. P Lundsgaard-Hansen: Hemodilution--New clothes for an anemic emperor. *Vox Sang* 36:321-6 (1979).
22. P Lundsgaard-Hansen. *International Forum*. *Vox Sang* 58:248-50 (1990).
23. SA Gould, AL Rosen, LR Sehgal, et al. Fluosal-DA as a red-cell substitute in acute anemia. *N Eng J Med* 314:1653-6 (1986).
24. RK Spence, JL Carson, RM Poses. Fluosol-DA as a red-cell substitute in acute anemia (Letter). *N Eng J Med* 315:1677 (1986).
25. Y Hermoni, RW Millard, M Gabel. Fluosol-DA as a red-cell substitute in acute anemia (Letter). *N Eng J Med* 315:1678 (1986).
26. GS Moss, LR Sehgal, SA Gould, HL Sehgal, AL Rosen. Alternatives to transfusion therapy. *Anesthesiol Clin N Am* 8:569-88 (1990).
27. WJ Moores, F DeVenuto, WH Heydorn, et al. Extending the limits of hemodilution on cardiopulmonary bypass using stroma-free hemo- globin solution. *J Thorac Cardiovasc Surg* 81:155-62 (1981).

**PERFLUOROCARBONS AS BLOOD SUBSTITUTES: THE
EARLY YEARS.
EXPERIENCE WITH FLUOSOL DA-20% IN THE 1980s**

R. K. Spence MD , E. D. Norcross MD¹ , Joseph Costabile MD,
Sue McCoy MD², Aurel C Cernaianu MD, James B Alexander
MD, Mark J Pello MD, Umur Atabek MD, Rudolph C Camishion
MD,

3 Cooper Plaza, Suite 411, Camden, NJ 08103, ¹ Medical
University of South Carolina, 171 Ashley Avenue,
Charlestown, SC 29425-2270, ²Dept. of Surgery, Box
19750A, East Tennessee State Univ., Quillen Disher College of
Medicine, Johnson City, TN 37614-0002

ABSTRACT

Clinical testing of perfluorocarbons (PFC) as blood substitutes began in the early 1980's in the form of Fluosol DA-20% (FDA), a mixture of perfluorodecalin and perfluorotripropylamine emulsified with Pluronic F68. We have treated 55 patients (Treatment (T) = 40; Control (C) = 15) with intravenous infusions of 30 cc/kg of FDA as part of either a randomized, clinical trial or a humanitarian protocol. All patients were Jehovah's Witnesses who refused blood transfusion and were severely anemic (mean hemoglobin = 4.6 g/d). FDA successfully increased dissolved or plasma oxygen content (PIO₂ in ml/dl), but not overall oxygen content (T group: PIO₂ baseline = $1.01 \pm .27$, PIO₂ 12hrs =

1.58±.47 [$p < .0001$, t-test]; PIO₂ 12hrs: T = 1.58±.47, C = 1.00±.31, $p < .0002$, t-test). This effect persisted for only 12 hours post infusion, and had no apparent effect on survival. FDA is an ineffective blood substitute because of low concentration and short half-life. Improved emulsion design may resolve these problems, thereby producing a more effective agent. Our discussion will include a review of our data plus a summary of other reports of FDA efficacy as a blood substitute.

INTRODUCTION

Perfluorocarbons (PFC) arrived on the clinical scene in the early 1980's, accompanied by much fanfare. The excitement produced by the promise of a readily-available artificial blood substitute for the treatment of the anemic patient was fueled in part by the recent acknowledgement that the world's blood supply was tainted by the virus responsible for AIDS. Perfluorocarbons were ideal candidates as a substitute since they carried oxygen efficiently and in large quantities, were not biologically active, and did not have the problems and encumbrances associated with homologous blood transfusion -- or so it was thought. Unfortunately, the perfluorocarbons, in the form of Fluosol-DA 20%® (Green Cross, Osaka, Japan) did not live up to their promise as the "complete" blood substitute for a variety of reasons. In the following pages, we will review the early history of the development and clinical use of perfluorocarbons in the treatment of anemia as a means of better understanding their role in the future.

DISCUSSION

Perfluorocarbons were first considered as potential blood substitutes in the 1960's by Leland Clark, who

demonstrated their ability to carry oxygen insufficient to allow survival of liquid-breathing mice. [1] Following this dramatic introduction of the potential of perfluorocarbons, Naito explored varying combinations of chemicals, searching for a balance between oxygen carrying ability and tissue retention, eventually producing and testing Fluosol-DA 20%. This product, a combination of perfluorodecalin and perfluorotripropylamine emulsified with Pluronic F68, was first tested clinically in adult volunteers in Japan as described by Ohyanagi and Saitoh. [2] These authors reported that, as of 1986, over 400 patients had been treated in Japan with Fluosol, but they gave detailed information on only seven. These patients were all Jehovah's Witnesses who had had recent bleeding. Following an initial test dose of 0.5 ml, they all received an infusion of 30 ml/kg of Fluosol. PFC and plasma phase oxygen contents increased although overall oxygen content did not change. Hemodynamics remained stable and no adverse reactions were noted.

Clinical trials of Fluosol began in the United States in 1979 and continued into the mid-1980's until they were discontinued. Three reports of this experience have been published along with a few reports of individual cases. Tremper described the initial United States experience in 1982 with 13 patients. [3] Six had been treated as part of an humanitarian protocol with no data collection. His article summarized the results of the seven remaining severely anemic patients (hemoglobin range = 1.9 to 7.5 gm/dl) who had been entered into a trial designed to evaluate the clinical safety of Fluosol and to determine the product's effect on both oxygen transport and hemodynamic variables. Two of the seven patients reacted to an initial test dose, one with vague symptoms, the other with a "noticeable clinical

reaction." The authors also noted transient decreases in white blood cell counts in three patients. These adverse effects were thought to be due to complement activation, and premedication with steroids was suggested as a possible preventive treatment. Arterial oxygen content was significantly increased in these patients by 0.8 volume percent and oxygen consumption also increased. Cardiac index was also noted to decrease from an elevated mean level of 5.3 ± 1.6 liters/minute/square meter body surface area. All patients were reported to have had an objective improvement.

This group subsequently reported on the use of Fluosol in six bleeding Jehovah's Witness patients. [4] It is unclear if these patients were included in the initial report. None of these patients had adverse reactions to the test dose, but one became hypotensive when the infusion volume and rate were increased. Five of six had a transient decrease in white cell count. Moreover, three patients developed syndromes consisting of fever, leucocytosis, and infiltrates on chest reontgenogram. It was impossible to determine if Fluosol was responsible for these changes. All patients showed a small increase in calculated arterial oxygen content while breathing 100% oxygen after the infusion was complete. This was a significant change when compared to the increase with oxygen noted before infusion. Five of the six also had increases in oxygen consumption, but the importance of this change in terms of overall oxygen dynamics and outcome was not determined. The authors primarily emphasized both the nature and the severity of the adverse reactions encountered in this small group.

Karn et al reported their experience with two patients who had received Fluosol following massive postpartum hemorrhage. [5] Both had hemoglobin concentrations of 3

gm/dl or lower. Arterial PO₂ rose after Fluosol infusion in both patients and both heart rate and cardiac index decreased, but the effect was transient.

Perhaps the most significant report, at least in terms of its effect on the future of Fluosol as a blood substitute, appeared in 1986. [6] This group reported on their experience in using Fluosol in a small number of patients with hemoglobin concentrations below 3 gm/dl. The need for additional oxygen had been demonstrated by the patients' failure to respond to 100% oxygen breathing by a change in oxygen extraction ratio. Although Fluosol had a measurable effect in increasing both oxygen delivery and consumption, the authors concluded that the emulsion was of no benefit as a blood substitute in the anemic patient, in part because of the lack of any improvement in patient survival. Other investigators took issue with this conclusion, pointing out that Fluosol had improved oxygenation and that this group of patients was probably beyond salvage, even if they had received red cell transfusions. [7,8]

The randomized clinical trial of Fluosol in the treatment of severe anemia was stopped in the mid-1980's but results of the group of approximately 70 patients was never published. Our report of 46 patients involved in this study appeared in 1990. [9] We continued to enroll patients to the Fluosol treatment group until recently and report the cumulative results here of 45 patients who received Fluosol plus 10 who were randomized to a control group. All patients were Jehovah's Witnesses who refused blood transfusion and were severely anemic (mean hemoglobin = 4.6 g/d) following acute blood loss. A total of 30 ml/kg of Fluosol was infused following a test dose of 0.5 ml demonstrated no reaction. Fluosol successfully increased dissolved or plasma oxygen content (PIO₂ in ml/dl) twelve

hours after infusion, but not overall oxygen content when compared to the control group (PIO₂ 12hrs: T = 1.58±.47, C = 1.00±.31, p=<.0002, t-test). In addition, a significant change from baseline values was noted in the treated patients (Treatment group: PIO₂ baseline = 1.01±.27, PIO₂ 12hrs = 1.58±.47; p=<.0001, t-test). None of the patients had adverse reactions to either the test dose or the infusion, but several had been pretreated with corticosteroids. Moreover, the infusion protocol was not continued in four other patients who had reactions to the test dose characterized by chest pain and transient elevations in pulmonary pressure. Fluosol's effect persisted for only 12 hours post infusion, and had no apparent effect on survival.

What conclusions can be drawn from these early studies of the safety and efficacy of Fluosol-DA 20% as a blood substitute in anemic patients? Safety clearly was an issue with consistent reports of reactions to a 0.5 ml test dose of the emulsion. Although the reaction could be blocked with corticosteroids, such action is not justifiable except in extreme circumstances. Subsequent reports have implicated the surfactant, Poloxamer 188, as the responsible agent. [10] Improvements in the form of better purification have resulted in fewer reactions in the use of Fluosol during coronary angioplasty. [11] A recent report of potential toxicity from the Fluosol particle surface points out the need for further investigation. [12]

All of the above studies demonstrated in one form or another that Fluosol was capable of increasing dissolved oxygen content during 100% oxygen breathing. In other words, Fluosol had lived up to its biochemical promise as an oxygen carrier. Unfortunately, it did not live up to its expectation as a total blood substitute because of the limited amount of oxygen delivered and the short duration of effect.

Both limitations are functions of the emulsion design and concentration, not of an inherent failure of perfluorocarbon. Fluosol-DA 20% is an emulsion that contains only 11% weight per unit volume of active perfluorocarbon. This small amount of chemical should not have been expected to provide the equivalent in oxygen delivery of eight to ten grams of hemoglobin, the amount of blood lost by the majority of patients studied. The choice of a perfluorocarbon for clinical use requires balancing oxygen transport capabilities with tissue retention. The two agents in Fluosol, perfluorodecalin and perfluorotripropylamine, have markedly different tissue half-lives, with the latter perfluorocarbon persisting for weeks following infusion in the experimental animal. Unfortunately, little is known at this time about the long term effects of perfluorocarbon retention, so dosing regimens must be restricted to those which avoid any chance of tissue accumulation. This concern limited the amount of Fluosol that was given to patients in the anemia trials to a one-time dose of 30 cc/kg. As a result, the emulsion's effect was short-lived.

Although Fluosol-DA 20% can be regarded as a failure in its initial trial as a blood substitute, perfluorocarbons should not be dismissed as potential oxygen carriers. Emulsions with higher perfluorocarbon concentrations can help solve the problem of minimal oxygen delivery. [13] These agents can be used in short-term settings, e.g., during hemodilution, to significant advantage as temporary alternatives to homologous blood transfusion. Rather than abandon perfluorocarbons completely, we should abandon our ill-conceived expectations for them as artificial blood and concentrate on the development of appropriate applications for this unique family of chemicals.

REFERENCES

1. LC Clark Jr, F Gollan, Survival of mammals breathing organic liquids equilibrated with oxygen at atmospheric pressure, *Science*, 152, 1755-6, (1966).
2. H Ohyanagi, Y Saitoh, Development and clinical application of perfluorochemical artificial blood, *Int J Artif Organs*, 9(5), 363-8, (1986).
3. KK Tremper, AE Friedman, EM Levine, et al, The preoperative treatment of severely anemic patients with a perfluorochemical oxygen-transport fluid. Fluosol-DA, *N Engl J Med*, 307, 277, (1982).
4. K Waxman, KK Tremper, BF Cullen, et al, Perfluorocarbon Infusion in Bleeding Patients Refusing Blood Transfusions, *Arch Surg*, 119, 721-4, (1984).
5. KE Karn, PL Ogburn Jr, T Julian, et al, Use of a Whole Blood Substitute, Fluosol-DA 20%, after Massive Postpartum Hemorrhage, *Obst Gyn*, 65(1), 127-30.
6. SA Gould, AL Rosen, LR Sehgal, et al, Fluosol-DA as a red cell substitute in acute anemia, *N Engl J Med*, 314, 1653-56, (1986).
7. RK Spence [letter], Fluosol-DA as a red cell substitute in acute anemia, *N Engl J Med*, 315, 1677, (1987).
8. JG Riess, Fluorocarbon-based in vivo oxygen transport and delivery systems, *Vox Sang*, 61(4), 225-39, (1991).
9. RK Spence, S McCoy, J Costabile, et al, Fluosol DA-20 in the treatment of severe anemia: randomized controlled study of 46 patients, *Crit Care Med*, 18(11), 1227-30, (1990).
10. DE Hammerschmidt, GM Vercellotti, Limitation of complement activation by perfluorocarbon emulsions: superiority of lecithin-emulsified preparations, In: Chang

TM, Geyer RP eds. Blood substitutes, New York:Dekker, 431-8, (1989).

11. KM Kent, MW Cleman, MJ Cowley, et al, Reduction of myocardial ischemia during percutaneous transluminal coronary angioplasty with oxygenated Fluosol, A J Cardiol, 66(3), 279-84, (1990).

12. F Hong, KA Shastri, GL Logue, et al. Complement activation by artificial blood substitute Fluosol: in vitro and in vivo studies. Transfusion, 31, 642-647, (1991).

13. J.G. Riess, Blood Substitutes: Where do we stand with the fluorocarbon approach to in vivo oxygen delivery, Biomaterial, Artificial Cells, Immob. Biotech, 20, 183-204 (1992).

IMPROVEMENT IN CIRCULATORY AND OXYGENATION STATUS
BY PERFLUBRON EMULSION (OXYGENT™ HT) IN A CANINE
MODEL OF SURGICAL HEMODILUTION

A.C. Cernaianu M.D., R.K. Spence M.D., T.V. Vassilidze M.D., Ph.D., J.G. Gallucci M.D., T. Gaprindashvili M.D., Ph.D., A. Olah M.D., R.L. Weiss M.D., J.H. Cilley Jr. M.D., P.E. Keipert Ph.D.* , N.S. Faithfull M.D., Ph.D.*, and A.J. DelRossi M.D.

Department of Surgery and Medicine, UMDNJ-Robert Wood Johnson Medical School, Camden, NJ, and Alliance Pharmaceutical Corp.*, San Diego, CA, USA.

ABSTRACT

To examine the effect of a low dose of Oxygent™ HT on hemodynamics and oxygen transport variables in a canine model of profound surgical hemodilution, two groups of adult anesthetized splenectomized beagles were hemodiluted with Ringer's solution to Hb 7 g/dL. The treated group received 1 mL/kg Oxygent™ HT (90% w/v perflubron emulsion [perfluorooctyl bromide], Alliance Pharmaceutical Corp.) and both groups (7 controls and 10 treated) were further hemodiluted using 6% hydroxyethyl starch until cardiorespiratory decompensation occurred. Pulmonary artery catheterization data and oxygen transport variables were recorded at Hb decrements of 1 g/dL breathing room air. There was no difference among groups during initial hemodilution. However, in the Oxygent™ HT group there was a statistically significant improvement in mean arterial pressure, CVP, cardiac output, PvO₂, SvO₂, DO₂ and pulmonary venous admixture shunt during profound hemodilution to Hb levels of 6, 5, and 4 g/dL. A low dose of Oxygent™ HT offered benefit in improving hemodynamics and oxygen transport parameters even under air breathing conditions in a model of surgical hemodilution. This effect was most apparent at lower levels of Hb.

INTRODUCTION

Recent awareness of the potential for transmission of infectious diseases by blood and many blood products, has been an important impetus for an increased

for the development of strategies that would eliminate or limit the need for allogeneic blood transfusions [1]. The administration of blood has been associated with transfusion reactions [2-4], a predisposition to infectious complications post surgery, non-cardiogenic pulmonary edema [5], and with the induction of a certain degree of immunosuppression [6].

Because of these reasons and blood supply limitation [7], there is a tremendous interest in finding the best method or combination of methods for blood conservation following surgical bleeding. Aside from improvements in surgical hemostasis, a variety of other techniques have been advocated as reducing the amount of allogeneic blood. Preoperative autologous predonation [8-11], intraoperative blood salvage techniques [12], acute intentional normovolemic hemodilution [13], pharmacologic manipulation of the coagulation cascade [14-17], the use of oxygen carriers [18], and the control of unnecessary blood waste for laboratory tests in the postoperative period [19], or any combination of those have been advocated to reduce the amount of allogeneic blood or blood products post operatively. Hemodilution has proven to increase blood fluidity, decrease erythrocytes and thrombocyte aggregation, reduce plasma viscosity, decongest terminal circulation, and improve microcirculation and tissue oxygenation [20]. There are however some problems with this technique. Performing hemodilution safely assumes adequate knowledge of the normal human response to acute severe anemia, as well as the safe human limits to this response. Some of the questions yet to be answered are related to the cardiovascular and metabolic responses to severe anemia created by hemodilution. [21,22] It remains also to define the critical, however safe level of oxygen transport during severe hemodilution.

Perfluorocarbons (PFC) are a group of inert organic molecules long known to have the capacity to carry oxygen [23]. Fluosol-DA 20% was one of the first commercially available biocompatible PFC emulsions. In 1979, clinical trials using Fluosol-DA 20% as a large volume temporary blood substitute in severely anemic patients were initiated [24-28]. Recently, stable emulsions containing significantly higher concentration of PFC's and therefore higher oxygen carrying capacity than Fluosol-DA 20% have been developed [29,30]. One of these is a concentrated emulsion based on perflubron (perfluorooctylbromide; PFOB) being developed under the trade name, Oxygent™ HT (Alliance Pharmaceutical Corp., San Diego, CA). With perflubron in the presence of an egg yolk phospholipid (EYP) emulsifier it is possible to produce highly concentrated stable emulsions that contain up to 100% w/v perflubron that require no special preparation prior to use [31]. Oxygent™ HT is a 90% w/v perflubron emulsion formulation being developed for use as a temporary oxygen carrier because of the high solubility of oxygen in perflubron (53 volumes % when equilibrated with 100% oxygen).

The purpose of this study was to investigate the effects of perflubron emulsion on hemodynamics and oxygen transport variables under air-breathing conditions in a canine model of profound surgical hemodilution.

METHODS

This study was conducted on 17 adult conditioned beagles, weighing 20-25 kg. Dogs were fasted 24 hours prior to the experiment except for access to water. Anesthesia was induced and maintained with 1.4% to 1.6% isoflurane. With endotracheal intubation, animals were ventilated with an FiO_2 of 21%. To avoid sequestration of erythrocytes in the spleen, all animals underwent surgical splenectomy through a left subcostal incision. This allowed maintenance of a stable hematocrit after blood exchange.

The left femoral vein was cannulated for the administration of IV fluids and the left femoral artery was cannulated for the direct measurement of arterial pressure and for arterial blood sampling. A fiberoptic pulmonary artery thermodilution catheter (Oximetrix, Abbott Critical Care Systems, Mountain View, CA) was inserted via the right external jugular vein. The right carotid artery was cannulated with a large bore polyethylene catheter which was connected to a heparinized Wigger's reservoir for collection of shed blood. A left thoracotomy was performed and the pericardium was opened. A catheter was placed in the coronary sinus for blood sampling for measurement of lactic acid levels (ACA lactic acid method, DuPont Automatic Clinical Analyzer, DuPont Pharmaceutical, Wilmington, DE). Seventeen animals underwent an initial isovolemic hemodilution procedure in decrements of hemoglobin (Hb) of 1 g/dL until they reached a target hematocrit of 20%. No medication was used to manipulate the blood pressure. Ringer's solution was reinfused in a 3:1 ratio via the central venous catheter to replace the blood removed and to maintain the pulmonary artery occlusion pressure (PAOP) at baseline values. When Hb reached 7 g/dL, complete pulmonary artery catheterization data, and oxygen transport parameters were recorded on room air ($FiO_2 = 21\%$). At the level of 7 g/dL of Hb, a single set of measurements were made for comparison while breathing 100% oxygen. Then animals were switched back to room air and randomly administered either a bolus of 1 mL/kg saline (group I, control, $n = 7$), or 1 mL/kg Oxygent™ HT (Group II, treatment, $n = 10$). Both groups were ventilated on room air for the duration of the study and underwent further hemodilution with 6% hetastarch (DuPont Pharmaceutical, Wilmington, DE) at a ratio of 1:1 with the blood removed. Hemodynamic and oxygen transport measurements were recorded periodically during hemodilution with hetastarch as previously described in decrements of Hb of 1 g/dL until cardiorespiratory decompensation occurred. Ten minutes after each hemodilution, cardiorespiratory and oxygen transport variables, consisting of measurements of pulmonary artery pressure (PAP), central venous pressure (CVP), pulmonary artery occlusion pressure (PAOP), cardiac output (Q), and oxygen transport variables such as intrapulmonary shunt (Q_s/Q_t), arterial-venous oxygen content difference [$C(a-v)O_2$], oxygen delivery (DO_2), oxygen consumption (VO_2), mixed venous oxygen saturation (SvO_2), oxygen utilization coefficient (OUC), and coronary sinus lactate measurements were obtained. Cardiorespiratory monitoring was performed with a SpaceLabs monitoring system

(SpaceLabs Medical, Inc., Seattle, WA). Total oxygen content was measured with a LEX-O₂-CON instrument (Hospex Fiberoptics, Chestnut Hill, MA). Hemoglobin concentration and hematocrit were measured with a STKS Coulter counter (Coulter, Miami FL), and the arterial and venous blood gases were analyzed with a Corning blood gas analyzer. At the end of the procedure, the animals were euthanized by anesthetic overdose according to the Vivarium protocol. During the entire protocol animals received humane care in compliance with the "Principles of Laboratory Animal Care" and the "Guide for the Care and Use of Laboratory Animals" published by the NIH. (publication No. 86-23, 1985).

Statistical analysis was performed using SPSS PC Plus (version 3.0) on an IBM PC compatible computer. Descriptive statistics, t-test and analysis of variance were performed as appropriate. A p-value less than 0.05 was considered statistically significant. Data are presented as mean \pm standard error of the mean.

RESULTS

There was no statistically significant difference between the groups with regard to weight, body surface area (BSA) or any intraoperative characteristics. There was no statistically significant difference between the groups with regard to the hemodynamics and oxygen transport parameters at Hb levels greater than 15, 14, 11, 9, and 7 g/dL on room air.

The hemodynamic variables during air-breathing hemodilution are presented in Table I. There was a statistically significant difference in MAP during the hemodilution protocol at Hb levels of 6, 5, and 4 g/dL between the two groups. Cardiac output was statistically significant higher at Hb levels of 5 and 4 g/dL in the perflubron-treated group. Also, a statistically significant decrease in PVR at Hb levels of 6, 5 and 4 g/dL, and a statistically significant increase in LVSWI and RVSWI at Hb levels of 6, 5, and 4 g/dL was observed in the perflubron-treated animals.

The administration of 1 mL/kg perflubron emulsion at a Hb level of 7 g/dL on room air, resulted in a statistically significant increase in SaO₂, CaO₂, and SVR. There was no statistically significant difference between all other variables. There was a non-statistically significant trend to increase PaO₂, C(a-v)O₂, SvO₂, total O₂ content, CvO₂, and OUC. When control animals were switched to 100% oxygen, there was a statistically significant decrease in CVP (4.6 \pm 0.8 vs. 2.5 \pm 0.5 cmH₂O), Q (3.7 \pm 0.4 vs 2.1 \pm 0.4 L/min), DO₂ (334 \pm 38 vs 223 \pm 35 mL/min), LVSWI (38 \pm 6 vs 19 \pm 5 gm/m²) and RVSWI (39 \pm 6 vs 21 \pm 6 gm/m²) and a significant increase in PaO₂ (79 \pm 9 vs 499 \pm 93 mm Hg), PvO₂ (40 \pm 3 vs 53 \pm 3 mm Hg), total arterial O₂ content (9 \pm 1 vs 12 \pm 2 mL/dL), SaO₂ (94 \pm 1 vs 99 \pm 1%), CaO₂ (9 \pm 0.1 vs 11 \pm 0.2 mL/dL).

Table I. Hemodynamic Profile During Hemodilution

Variable	Hemoglobin (g/dL)			
	7	6	5	4
MAP (mm Hg)				
Control	48±5	44±7	37±2	42±2
Treatment	57±2	76±5*	61±3*	52±2*
CVP (cm H ₂ O)				
Control	4.6±0.8	8±1	7±0.6	7±0.8
Treatment	5.3±0.9	4±0.6*	4±0.5*	4±0.3*
Q (L/min)				
Control	3.7±0.4	3.1±1.0	3.2±0.5	3.4±0.3
Treatment	3.2±0.3	3.3±0.1	3.5±0.3*	4.1±0.1*
SVR (dyne sec/ cm ⁵ m ²)				
Control	1037±137	1310±456	782±93	824±64
Treatment	1366±113*	1744±98	1362±127*	935±50
PVR (dyne sec/ cm ⁵ m ²)				
Control	143±15	134±40	181±21	179±22
Treatment	142±15	65±10*	124±13*	83±11*
LVS WI (gm/m ²)				
Control	38±6	30±13	24±4	26±4
Treatment	34±3	42±5*	45±5*	35±3*
RVS WI (gm/m ²)				
Control	39±6	29±13	24±4	27±4
Treatment	37±4	47±8*	51±6*	41±3*

Data presented as mean ± SEM. *represents statistical significance ($p < 0.05$) treatment group vs. control.

Table II. Arterial Oxygen Transport Parameters During Hemodilution

Variable	Hemoglobin (g/dL)			
	7	6	5	4
PaO ₂ (mm Hg)				
Control	79±9	61±0.7	77±10	65±11
Treatment	83±4	71±6.3*	93±10*	77±5*
PaCO ₂ (mm Hg)				
Control	29±3	30±5	30±2	32±3
Treatment	28±2	24±5	27±4	27±3
C(a-v)O ₂ (mL/dL)				
Control	2.3±0.3	2.1±0.4	2.6±0.2	2.1±0.2
Treatment	2.4±0.1	2.0±0.2	1.4±0.1*	1.4±0.6*
SaO ₂ (%)				
Control	94±1	95±3	95±2	92±2
Treatment	97±0.4*	99±1	94±2	95±1
CaO ₂ (mL/dL)				
Control	9.0±0.1	7.7±0.2	6.6±0.1	5.2±0.1
Treatment	9.3±0.4*	8.2±0.1	6.6±0.1	3.9±0.3
Total O ₂ Content (mL/dL)				
Control	9.0±1.0	5.7±0.3	6.5±0.6	5.3±0.5
Treatment	9.6±0.3	10.1±0.9*	7.6±0.5	6.1±0.3

Data presented as mean±SEM. *represents statistical significance ($p < 0.05$) treatment group vs. control.

The elements of arterial oxygen transport profiles during hemodilution are presented in Table II. Perflubron treated-animals, despite breathing room air, presented with a statistically significant increase in PaO₂ at Hb levels of 6, 5, and 4 g/dL, a statistically significant increase in C(a-v)O₂ at Hb levels of 5, and 4 g/dL and a statistically significant increase in total oxygen content at Hb level of 6 g/dL.

Table III shows elements of the mixed venous oxygenation. Perflubron-treated animals presented with a statistically increased SvO₂ at Hb levels of 6, 5, and 4 g/dL and a statistically significant increased CvO₂ at Hb levels of 5, and 4 g/dL.

Table III. Mixed Venous Oxygen Transport Parameters During Hemodilution

Variable	Hemoglobin (g/dL)			
	7	6	5	4
PvO ₂ (mm Hg)				
Control	40±3	44±9	40±5	30±2
Treatment	40±2	52±10	44±2	38±2*
PvCO ₂ (mm Hg)				
Control	34±2	39±4	36±3	36±4
Treatment	33±3	29±8	29±3	36±5
SvO ₂ (%)				
Control	70±3	59±5	57±2	54±32
Treatment	72±2	74±2*	76±2*	70±0.5*
CvO ₂ (mL/dL)				
Control	6.7±0.3	5.6±0.4	3.9±0.1	3.0±0.2
Treatment	7.3±0.3	6.2±0.2	5.2±0.1*	3.9±0.3*

Data presented as mean±SEM. *represents statistical significance ($p < 0.05$) treatment group vs. control.

Other oxygen transport parameters are shown in Table IV. There was a statistically significant decrease in Qs/Qt at Hb levels of 6 g/dL. Also, OUC decreased significantly at Hb levels of 5 and 4 g/dL and DO₂ showed a non-statistically significant trend toward being increased at Hb levels of 6, and 5 g/dL. However, the differences reached statistical significance only at a Hb level of 4 g/dL.

There was no statistically significant difference between the groups with regard to any variables at a Hb level of 3 g/dL. The administration of 1.0 mL/kg dose of Oxygent™ HT (90% w/v perflubron solution) was safe. There was no detectable incidence of side effects related to the administration of this dose of perflubron emulsion in acutely hemodiluted dogs.

DISCUSSION

Acute normovolemic hemodilution is a simple strategy to intentionally remove red blood cells from the patient's circulation, while maintaining normovolemia by

Table IV. Other Oxygen Transport Parameters During Hemodilution

Variable	Hemoglobin (g/dL)			
	7	6	5	4
DO ₂ (mL/min)	334±38	237±72	210±29	173±13
Control	302±26	270±12	234±22	212±11*
Treatment				
VO ₂ (mL/min)	92±16	63±12	80±11	72±9
Control	77±5.9	66±9	50±8*	60±5
Treatment				
OUC (%)				
Control	0.24±0.04	0.27±0.08	0.40±0.02	0.43±0.03
Treatment	0.26±0.02	0.26±0.03	0.21±0.03*	0.29±0.01*
Qs/Qt (%)				
Control	25±5	26±13	15±5	22±5
Treatment	13±1	11±1*	25±6	22±4
Lactate (mmol/L)	3.2±1.1	7.0±3.3	4.4±1.8	4.1±2.1
Control	3.6±0.5	7.1±2.6	3.1±0.6	6.9±1.2
Treatment				

Data presented as mean±SEM. *represents statistical significance ($p < 0.05$) treatment group vs. control.

simultaneous replacement of the depleted intravascular volume with crystalloid or colloid solution. The removed autologous blood can be reinfused later according to the patient's needs. Acute normovolemic hemodilution is being used more frequently in different clinical settings in order to avoid the need for allogeneic blood transfusion. Although hemodilution is a procedure well tolerated by the majority of patients, the progressive changes in hemodynamics and oxygen transport parameters during normovolemic hemodilution have been only partially models of sepsis and intestinal ischemia [32]. In addition, the merits of resuscitation with Ringer's lactate remain questionable depending on the severity of the hemorrhagic shock model [33-35]. These solutions do not carry oxygen and therefore can only improve oxygen delivery through their hemodynamic effect as plasma expanders.

The advent of the development of improved second generation high concentration and stable perfluorocarbon emulsions, (Oxygent™ HT, Alliance Pharmaceutical, San Diego, CA) has increased the chance of using the perfluorocarbon emulsion approach to enhance total oxygen transport. This new generation perflubron-based emulsion contains up to five times more perfluorocarbon (up to 100% by weight or 52% by volume) than Fluosol-DA 20%. It also contains an EYP surfactant which is better tolerated than the synthetic surfactant (Pluronic) used in Fluosol-DA which has been at least partially related to life-threatening side effects due to activation of the complement pathway [7]. Being ready to use at room temperature, Oxygent™ HT has the potential to be used as an oxygen carrier in a series of clinical situations such as severe hemorrhagic shock, or as an adjuvant to enhance the oxygen transport mechanism in ischemia-related injuries. One such situation may result during normovolemic hemodilution which has been characterized by some investigators [36] to decrease the capacity of arterial blood to carry oxygen, especially in the areas at risk due to compromised cardiovascular reserves such as coronary artery atherosclerosis. Our study was designed to evaluate the ability of perflubron emulsion to improve oxygen transport mechanisms in a dog model of extreme isovolemic hemodilution.

Our data demonstrated that the infusion of a single, 1.0 mL/kg dose of Oxygent™ HT to a hemodiluted dog breathing room air increased the ischemic tolerance, by improving almost all hemodynamic and oxygen transport parameters during subsequent additional hemodilution. This effect was sustained at Hb levels much lower than the actual accepted standard clinical level of anemia which is considered safe by many investigators [37]. Our data demonstrated that it is possible to actually increase the physiologic limits of hemodilution using Oxygent™ HT without diminishing the cardiorespiratory reserve, thus maintaining normal range hemodynamics and oxygen supply to the tissues.

The effects of perflubron emulsion during hemodilution are ascribed at least in part to the high propensity of the drug to carry and dissolve oxygen and carbon dioxide, its small emulsion particle size, biological inertness, and homogenization with blood and its components which may improve blood microrheology. This in turn may help redistribution of oxygen supply in tissue areas at need. The administration of Oxygent™ HT has been proven safe in this animal model of extreme isovolemic hemodilution. There have been no signs of hemodynamic collapse such as those observed after the administration of Fluosol-DA 20% in administration of Oxygent™ HT has been proven safe in this animal model of extreme isovolemic hemodilution. There have been no signs of hemodynamic collapse such as those observed after the administration of Fluosol-DA 20% in experimental canine models [38]. Under 100% oxygen breathing condition, significant improvement of the oxygen transport variables, following administration of 3 mL/kg of Oxygent™ HT, has recently been demonstrated in a dog model of profound hemodilution [39].

In conclusion, our results demonstrated that perflubron-treated animals presented with statistically significant improvement in hemodynamics and oxygen transport

parameters even under air-breathing conditions. The effect was very apparent at Hb 6, 5, and 4 g/dL. From the significant improvement seen in oxygen transport variables when dogs were switched to 100% oxygen (at Hb level of 7 g/dL), it is clear that the optimal efficacy of low-dose perfluorocarbons emulsion will be obtained when breathing 100% oxygen (e.g., during the active bleeding phase of a surgical procedure where Oxygent™ HT has been administered as a temporary oxygen carrier to avoid or delay the need for allogeneic blood transfusion). It should be determined if initial treatment with perflubron may have a protective effect even at higher level of Hb. It is yet to be determined if this promising approach to enhance oxygen transport parameters would translate to improved long-term survival.

REFERENCES

1. LT Goodnough, JM Shuck. Risk, options and informed consent for blood transfusion in elective surgery. *Am J Surg* 159:602-9 (1990).
2. K Sazama. Reports of 355 transfusion-associated deaths:1976-1985. *Transfusion* 30:583-90 (1990)
3. V von Fieldner, DJ Higby, U Kim. Graft-versus-host reactions following blood product transfusion. *Am J Med* 72:951-61 (1982).
4. M Thaler, A Shamiss, S Orgad, et al. The role of blood from HLA-homozygous donors in fatal transfusion-associated graft-versus-host disease after open-heart surgery. *N Engl J Med* 321:25-8 (1989).
5. M Magart, S Stewart. The mechanism and management of noncardiogenic edema following cardiopulmonary bypass. *Ann Thor Surg* 43:231-6 (1987).
6. PA Schriemer, DE Longnecker, PD Mintz. The possible immunosuppressive effects of perioperative blood transfusion in cancer patients. *Anesthesiology* 68:422-8 (1988).
7. SL Nyberg, FB Cerra. Treatment of severe anemia with perfluorocarbon blood substitutes: a clinical overview. *Clin Intensive Care* 4:226-32 (1991).
8. PTCY Toy, RG Strauss, LG Stehling, et al. Predeposited autologous blood for elective surgery. A national multicenter study. *N Engl J Med* 316:517-20 (1987).
9. M Mann, HG Sacks, D Goldfinger. Safety of autologous blood donation prior to elective surgery for a variety of potentially "high-risk" patients. *Transfusion* 23:229-32 (1983).

10. DV Owings, MS Kruskall, RL Thurer, LM Donovan. Autologous blood donation prior to elective cardiac surgery; safety and effect on subsequent blood loss. *JAMA* 262:1963-68 (1989).
11. AJ DelRossi, AC Cernaianu, RA Vertrees, et al. Platelet-rich plasma reduces postoperative blood loss after cardiopulmonary bypass. *J Thorac Cardiovasc Surg* 100:281-86 (1990).
12. DH Clemens, TP Sculco, SW Burje, K Mayer, DB Levine. Salvage and reinfusion of postoperative sanguineous wound drainage. *J Bone Joint Surg* 74A:646 (1992).
13. K Messmer, U Kreimeier, M Intaglietta. Present state of intentional hemodilution. *Eur Surg Res* 18:254 (1986).
14. AJ DelRossi, AC Cernaianu, S Botros, GM Lemole. Prophylactic treatment of postperfusion bleeding with EACA. *Chest* 96:27-30 (1989).
15. LS Czer, TM Bateman, RJ Gray, et al. Treatment of severe platelet dysfunction and hemorrhage after cardiopulmonary bypass; reduction of blood products usage with desmopressin. *J Am Coll Cardiol* 9:1139-47 (1987).
16. BP Bidstrup, D Royston, RN Salford, KM Taylor. Reduction of blood loss and blood use after cardiopulmonary bypass with high dose aprotinine (Trasyol). *J Thorac Cardiovasc Surg* 97:364-72 (1989).
17. C Vedrinne, C Girard, O Jegaden, et al. Reduction of blood loss and blood use after cardiopulmonary bypass with high dose aprotinine versus autologous fresh whole blood transfusion. *J Cardiothorac Vasc Anesth* 6:319-23 (1992).
18. KK Tremper, EM Friedman, R Levine, D Lapin, D Camarillo. The perioperative treatment of severely anemic patients with perfluorochemical oxygen transport fluid, Fluosol-DA. *N Engl J Med* 307:277-83 (1982).
19. GE Foulke, DJ Harlow. Effective measures for reducing blood loss from diagnostic laboratory tests in the intensive care unit patients. *Crit Care Med* 17:1143-5 (1989).
20. J Koscielny, F Jung, H Kiesewetter, A Haass. Hemodilution. Springer-Verlag, New York (1992).
21. H Forst, J Racenberg, R Schosser, K Messmer. Right ventricular tissue

- PO₂ in dogs; effect of hemodilution and acute right coronary artery occlusion. *Res Exp Med* 187:159-74 (1987).
22. DR Spahn, LR Smith, RL McRae, BJ Leone. Effects of acute isovolemic hemodilution and anesthesia on regional function in left ventricular myocardium with compromised coronary blood flow. *Acta Anaesthesiol Scand* 36:628-36 (1992).
 23. KK Temper, ST Anderson. Perfluorochemical emulsion oxygen transport fluids. A clinical review. *Ann Rev Med* 30:309-13 (1985).
 24. H Ohyanagy, K Toshima, M Sekita, et al. Clinical studies perfluorochemical whole blood substitutes: safety of Fluosol-DA (20%) in normal human volunteers. *Clin Ther* 2:306-12 (1979).
 25. T Mitsuno, H Ohyanagy, R Naito. Clinical studies of a perfluorochemical whole blood substitute (Fluosol-DA). *Ann Surg* 195:60-9 (1982).
 26. SA Gould, AL Rosen, LR Sehgal, et al. Fluosol-DA as a red-cell substitute in acute anemia. *N Engl J Med* 314:1653-6(1986).
 27. LA Elliott, AM Ledgerwood, CE Lucas, et al. Role of Fluosol-DA 20% in prehospital resuscitation. *Crit Care Med* 17:166-72 (1989).
 28. RK Spence, S McCoy, J Costabile, et al. Fluosol-DA 20% in the treatment of severe anemia: randomized controlled study of 46 patients. *Crit Care Med* 18:1227-30 (1990).
 29. JD Riess, JL Dalfors, GK Hanna, et al. Development of high fluid concentrated and stable fluorocarbon emulsions for diagnostic and therapy. *Biomat Art Cell and Immob Biotech* 20:839-42 (1992).
 30. JG Riess, MP Krafft. Elaboration of fluorocarbon emulsions with improved oxygen carrying capacities. In: *Oxygen Transport to Tissue XVI*, Erdman W, Bruley DF (eds), Plenum Press, New York (1992).
 31. JG Riess. Fluorocarbons-based blood substitutes: What progress? *Int J Artif Org* 14:255-8 (1991).
 32. I Dawidson. Fluid resuscitation in shock: current controversies. *Crit Care Med* 17:1078 (1989).
 33. J Horton, R Landreneau, D Tyggle. Cardiac response to fluid resuscitation from hemorrhagic shock. *Surg Gynecol Obstet* 160:444 (1985).

34. AVS Rayer, GE Lambert, RL Fulton. Cardiac function during hemorrhagic shock and crystalloid resuscitation. *J Surg Res* 24:35 (1978).
35. P Wang, IH Chaudry. Crystalloid resuscitation restores but not maintain cardiac output following severe hemorrhage. *J Surg Res* 50:163-9 (1991).
36. DR Spahn, RL Smith, CD Veronee, et al. Acute isovolemic hemodilution and blood transfusion; Effects on regional function and metabolism in myocardium with compromised coronary blood flow. *J Thorac Cardiovasc Surg* 105:694-704 (1993).
37. JB Allen, FB Allen. The minimal acceptable level of hemoglobin. *Intern Anesth Clinics* 20:1-22 (1982).
38. RF Mattrey, PL Hilpert, CD Long, et al. Hemodynamic effects of intravenous lecithin-based perfluorocarbon emulsions in dogs. *Crit Care med* 17:652-6 (1989).
39. PE Keipert, NS Faithfull, JD Bradley, et al. Oxygen delivery agumentation by low-dose perfluorochemical emulsion during profound normovolemic hemodilution. *Oxygen Transport to Tissues XV*, Vaupel, P (ed), Plenum Press, NY (1993).

USE OF CURRENT GENERATION PERFLUOROCARBON EMULSIONS IN CARDIAC SURGERY

William L. Holman, M.D., David C. McGiffin, M.D., Walter V. A. Vicente, M.D., Ph.D.

Russell D. Spruell, BSEE, and Albert D. Pacifico, M.D.

Division of Cardiothoracic Surgery

University of Alabama at Birmingham

Birmingham, Alabama U.S.A.

ABSTRACT

The development of novel perfluorocarbon emulsions that contain higher concentrations of perfluorochemicals than previous emulsions has renewed interest in the use of this class of erythrocyte substitute in cardiopulmonary bypass (CPB). Perfluorocarbons have the potential to increase the oxygen content of the perfusate and thus increase the capacity of the heart-lung machine to deliver oxygen to the body during CPB.

Increasing the capacity of the heart-lung machine to deliver oxygen to the body has important implications for the conduct of cardiac operations. For example, adding perfluorocarbons to the pump prime solution may allow larger volumes of blood to be withdrawn from the patient immediately prior to bypass for transfusion after bypass. Lowering the acceptable hematocrit during CPB with the use of perfluorocarbons may also decrease the need for homologous transfusions of erythrocytes in neonates or anemic adults who undergo CPB.

INTRODUCTION

Perfluorocarbons have many intriguing properties with potential usefulness in medicine. The aspects of perfluorocarbons that are particularly interesting to cardiac surgeons are their ability to dissolve large amounts of oxygen relative to water and their linear oxygen dissociation curve. Current generation perfluorocarbon emulsions contain a higher concentration of

perfluorocarbon than previous formulations, which has stimulated renewed interest in their use as an erythrocyte substitute in cardiac surgery.

The majority of cardiac operations use cardiopulmonary bypass (CPB). In current practice, CPB routinely results in dilution of the patient's blood with the pump priming solution. The lowest acceptable hematocrit under the conditions of CPB has not yet been clearly defined [1-4], however surgeons generally maintain the hematocrit during cardiopulmonary bypass above 15-18%. Perfluorocarbon emulsions have the potential to raise the amount of oxygen carried in the perfusate during CPB. This may represent an important advantage for the conduct of cardiac operations.

This article will briefly describe the properties of perfluorocarbon emulsions that are of special interest to cardiac surgeons, then discuss potential uses for perfluorocarbon emulsions during CPB. Last, pilot studies will be described that compare the ability of various oxygenators to load perfluorocarbon emulsions with oxygen.

ADVANTAGES OF PERFLUOROCARBON EMULSIONS USED DURING CARDIOPULMONARY BYPASS

CPB routinely employs hemodilution, therefore any substance that can increase the oxygen carrying capacity of the perfusate during CPB has potential usefulness. Perfluorocarbon emulsions have several properties that are important in this regard.

Current perfluorocarbon emulsions contain up to 100% perfluorochemical on a weight/volume basis (roughly 50% perfluorochemical on a volume/volume basis). Thus they are able to carry substantially more dissolved oxygen than previous emulsions [5-7]. Moreover, the volume of oxygen dissolved in perfluorocarbon at a given PO_2 increases as the ambient temperature decreases but is independent of changes in pH. These are useful properties since cardiac operations frequently employ hypothermia during the period of CPB (body temperature ranging from 28° to 32° C in typical cases) and the pH may become alkalotic during hypothermic CPB.

The linear dissociation curve for oxygen dissolved in perfluorocarbon and the higher concentration of perfluorocarbon in current emulsions result in substantial amounts of dissolved oxygen if the emulsion is loaded at a high partial pressure of oxygen. Current oxygenator designs can reliably produce a PO_2 ranging from 400-600 Torr, which satisfies the condition for a high loading PO_2 .

The ideal erythrocyte substitute should be biologically inert beyond its capacity to carry oxygen. Surfactants used in previous formulations (including **Pluronic F-68**) have been shown to activate complement and occasionally cause anaphylactoid reactions [8-9]. This may be a

particularly adverse effect since complement activation and stimulation of a generalized inflammatory response is recognized as one of the routine sequelae of CPB [10]. Moreover, emulsion particles are taken up by the reticuloendothelial system. CPB also places demands on the reticuloendothelial system since fat emboli, damaged erythrocytes, and other particulate matter resulting from CPB must be cleared from the blood. The consequences of this additional load imposed on the reticuloendothelial system and any adverse effects on the liver or spleen have not yet been defined.

An especially intriguing aspect of perfluorocarbon emulsions is the effect that they may have on oxyhemoglobin dissociation. Plasma represents an important barrier to the diffusion of oxygen from erythrocytes to tissues [11-13]. It is possible that a substance with the ability to dissolve large quantities of oxygen relative to water can facilitate the diffusion of oxygen from erythrocytes. Initial studies suggest that perfluorocarbons in the plasma increase the rate of oxygen delivery from erythrocytes [14], however additional work is necessary to confirm and quantify this effect.

CARDIOPULMONARY BYPASS AND PERFLUOROCARBON EMULSIONS

1) Hemodilution and Cardiopulmonary Bypass

As mentioned previously, hemodilution is used routinely during CPB. However, this was not always the case. Early in the development of CPB the pump-oxygenator was primed with fresh heparinized blood. As one would expect, problems arose with transfusion related reactions and diseases transmitted via donor blood. In addition to these effects, a fatal syndrome of splanchnic congestion, metabolic acidosis, and multiorgan failure was noted in patients following CPB when whole blood was used to prime the pump-oxygenator [15]. These problems provided a strong incentive to explore the use of non-hemic priming solutions. In 1959, Panico and Neptune presented a series of 8 patients who underwent CPB with a non-hemic (i.e. normal saline) pump prime [16]. Similar successful results with non-hemic primes were reported by others, and hemodilution during CPB became standard practice.

Studies performed in the early era of CPB demonstrated that hemodilution ameliorated post-CPB pulmonary dysfunction and allowed autotransfusion with consequent improved post-CPB hemostasis. Moreover, whole body oxygen consumption during hypothermic CPB was similar with hemic or crystalloid primes, although hemodilution resulted in lower whole body oxygen consumption during normothermic CPB [17]. The lower limits of hemodilution were tested somewhat empirically in selected patients (e.g. Jehovah's Witnesses) and successful surgeries at hematocrits <20% during CPB were reported. Subsequently, studies by several groups confirmed the safety of routine hemodilution and autotransfusion in large numbers of patients.

Other laboratory and clinical studies added information regarding hemodilution during CPB. Moore *et al.* determined that hypothermia, heparin, and hemodilution during CPB decreased the generation of activated complement fractions C3a and C5a, and attenuated consequent neutrophil activation [18]. The optimal perfusate oncotic pressure during hemodiluted CPB was defined by Schupbach using a rabbit model [19] however the importance of colloid supplements to increase oncotic pressure with routine hemodilution during CPB remains controversial.

A 1981 study by Utley and associates [20] showed that hemodilution (hematocrit=25%) during hypothermic (temperature=25°C) CPB improves regional blood flow and oxygen delivery, although there was an associated increase in edema of the heart and intestinal tract. A study by Niinikoski and associates [21] documented that patients with intra-operative hematocrits of < 20% survive cardiac operations with no discernable increase in the incidence of peri-operative myocardial infarction. However, Buckberg showed the detrimental effect that profound hemodilution (hemoglobin < 5 gm/dl) has on subendocardial blood flow and cardiac function in the normal canine heart [22]. In this paper, he speculated that hearts with ventricular hypertrophy or coronary artery disease would probably not tolerate such low hemoglobin levels. Independent studies by Wechsler and Mendler confirmed that collateral dependent flow to endocardial tissue is compromised during hemodilution [23,24], and that this condition can result in regional contractile dysfunction. Moreover, the dilatory capacity of normal coronary arteries is limited during hemodilution [25]. These data suggest that hemodilution in the non-working heart on CPB has a greater margin of safety than hemodilution without CPB, particularly in diseased hearts. However, there is a lower limit below which myocardial (and presumably other organ) hypoxic injury will occur.

The information currently available regarding the optimal O₂ carrying capacity of blood during CPB is limited [1-4]. The challenge of studying hemodilution during CPB is formidable because of complexity imposed by the variety of flow rates and perfusion temperatures used during CPB. However initial studies are underway in this laboratory to develop methods for comparing hemodiluted CPB perfusates with or without added perfluorocarbon emulsions using total body oxygen consumption and cardiac oxygen consumption as outcome variables.

2) Oxygenator Design and Perfluorocarbon Emulsions

The first step in defining the optimal use of perfluorocarbons in cardiac surgery is to quantify the ability of various oxygenators to load perfluorocarbons with oxygen. Although there are many manufacturers of oxygenators, there are only three types of oxygenators currently in clinical use: bubble oxygenators, hollow fiber oxygenators, and membrane oxygenators.

Bubble oxygenators mix venous blood directly with oxygen dispersed as small bubbles. The air-oxygen interface provides adequate gas exchange, but also stimulates the inflammatory

response typically seen in association with CPB. Moreover, microembolization of air and direct trauma to formed blood elements increase as the blood-oxygen flow rate increases. Platelet activation and aggregation that results in post-CPB thrombocytopenia and platelet dysfunction tends to be more severe in oxygenators with direct air-blood interfaces, although this difference between bubble and true membrane oxygenators has been subtle in clinical trials.

Hollow fiber oxygenators use small tubes of microporous plastic for a gas exchange surface. Although they are often referred to as membrane type oxygenators, they in fact have direct gas-blood contact at the micropores. The initial versions of these oxygenators passed blood through the interior of the plastic tubes while passing the sweep gas around the outside. More recent versions of this oxygenator have reversed the position of the gas and blood phases. This decreases hemic trauma associated with forcing the blood through the small fibers.

True membrane oxygenators provide gas exchange across a non-porous material that is permeable to oxygen and carbon dioxide. The membrane is usually silastic that is set in a parallel array of sheets or configured as a "jelly roll". These oxygenators avoid gas-blood interfaces. This feature makes them useful for prolonged periods of extracorporeal oxygenation (i.e. ECMO), although the shorter term benefits are more difficult to discern.

All current oxygenators are disposable items that are primarily constructed from plastics and may use silicone defoaming agents. One issue that needs to be addressed in the future is the interaction of these materials with the components of perfluorocarbon emulsions. These interactions may be an important consideration if perfluorocarbons are released from emulsion by roller or vortex pumps, since the non-emulsified perfluorocarbons could then interact directly with plastic components or silicone-based defoaming agents.

Oxygenators also incorporate a venous reservoir that holds blood siphoned from the patient until it passes through the oxygenator. Perfluorocarbon emulsions have a higher specific gravity than blood. It is theoretically possible for the emulsion to settle out of suspension if the blood dwells in the reservoir for too long, however separation of blood-perfluorocarbon mixtures has not been noted in our initial experiments.

PRELIMINARY IN VITRO OXYGENATOR STUDIES

Preliminary studies have been performed in this lab to characterize the ability of various oxygenators to load perfluorocarbon emulsions with oxygen. These studies were performed in collaboration with scientists at Alliance Pharmaceutical Corporation (San Diego, CA 92121) using a 100% weight/volume emulsion of perfluorooctylbromide.

Methods and Materials

Three types of oxygenators were used: a bubble oxygenator (Baxter Healthcare Corp.; Irvine, CA 92714); a hollow fiber oxygenator (Baxter Healthcare Corp.; Irvine, CA 92714); and

TABLE I: UAB Pump-Oxygenator Priming Solution

Normosol*	1000 ml
D ₅ W	500 ml
NaHCO ₃ (1 mEq/ml)	15 ml
Heparin (1,000 U/ml)	6 ml

*Normosol is a balanced salt solution buffered to pH=7.4 (Abbott Laboratories, Inc.; North Chicago, IL 60064)

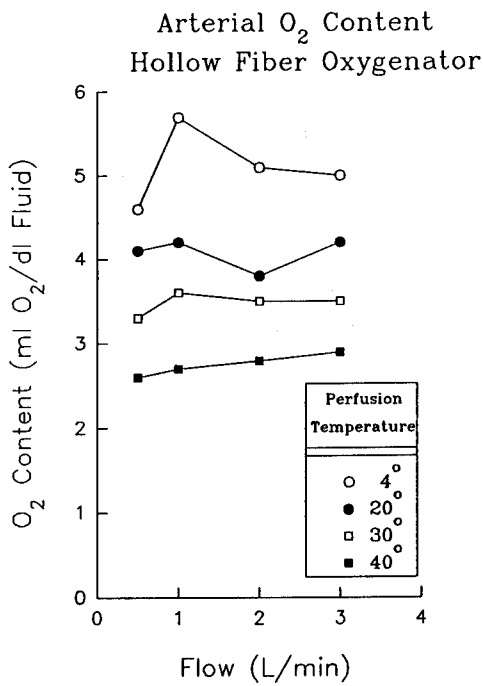

FIGURE 1: The arterial oxygen content (ml O₂/dl fluid) for a hollow fiber oxygenator circulating a mixture of crystalloid pump prime and Oxygent™ is displayed. There is a trend towards higher oxygen concentration at lower perfusion temperatures.

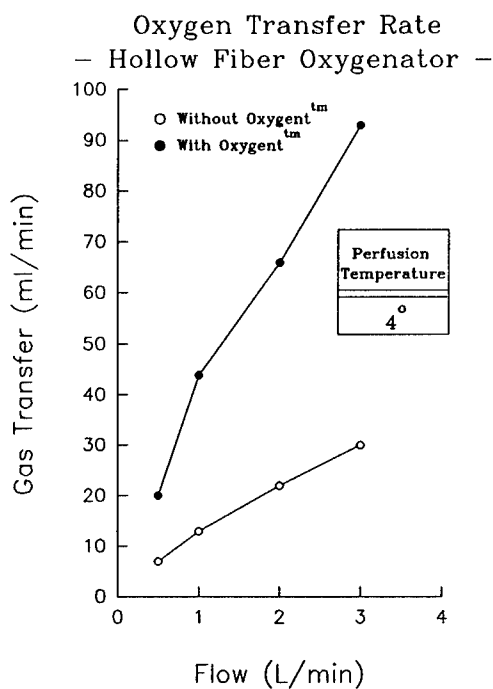

FIGURE 2: Oxygen transfer rate is shown for a hollow fiber oxygenator across a range of perfusate flow rates. The perfusate temperature was 4°C. The oxygen transfer rate at a flow of 1 or 2 L/min. is higher for the hollow fiber device than for the other oxygenators tested.

a membrane oxygenator (SCIMED Life Systems, Inc.; Minneapolis, MN 55441). Each test oxygenator was run in series with a bubble oxygenator that was gassed with 100% nitrogen to provide de-oxygenated fluid. The pump priming fluid was our standard crystalloid priming solution (Table I). In the perfluorocarbon trials, 250 ml of perfluorocarbon emulsion (Oxygent™ lot #ZY12093) was substituted for 250 ml of the priming solution. Pump rates of 0.5, 1.0, 2.0, and 3.0 l/min were tested at 40°, 30°, 20°, and 4° C. O₂ content was measured (Lex-O₂-Con fuel cell; Hospex Fiberoptics, Inc.; Chestnut Hill, MA 02167) and blood gas determinations were made (BGE 1400 Analyzer; Instrumentation Laboratories; Norcross, GA 30091). A calibrated roller pump provided the requisite flow rates and a screw clamp was used to balance flow between the O₂ and N₂ devices. The temperature of the fluid in the circuit was measured with probes in the oxygenators, and the circulating fluid was allowed to stabilize for

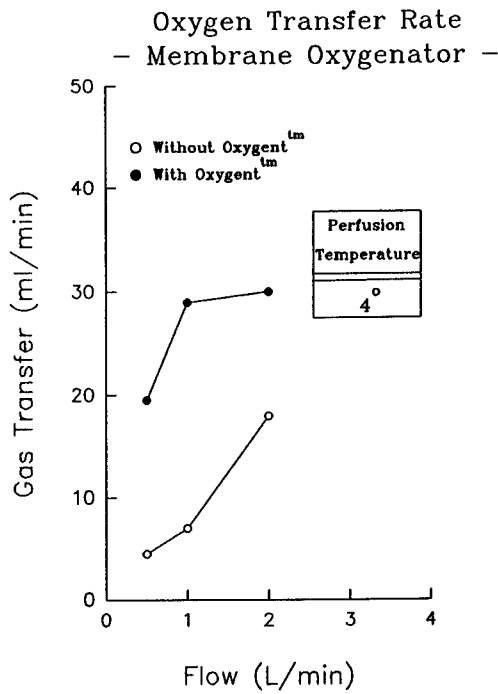

FIGURE 3: The oxygen transfer rate for a membrane oxygenator is displayed. The perfusate temperature was 4°C.

10 minutes after attaining each temperature-flow combination. Gas flow rates in the oxygenators were maintained at twice the fluid flow rate.

Results

Selected results from this study are shown in figures 1-4. The small number of oxygenators used in this pilot study (4 bubble, 1 membrane, and 2 hollow-fiber oxygenators) precluded meaningful statistical analysis, however there was a tendency for greater O₂ content in the perfluorocarbon prime at lower temperatures in all oxygenators (figure 1). Transfer of O₂ was highest using the hollow-fiber oxygenator (e.g. 66 ml O₂/min at 2 L/min flow and 4°C)(figure 2) as compared to the membrane device (30 ml O₂/min at 2 L/min flow and 4°C)(figure 3) or the bubble oxygenator (37 ml O₂/min at 2 L/min flow and 4°C)(figure 4).

Inferences

Additional data are being generated to allow statistical comparisons between oxygenator groups. However, the preliminary inference based on these data is that hollow fiber

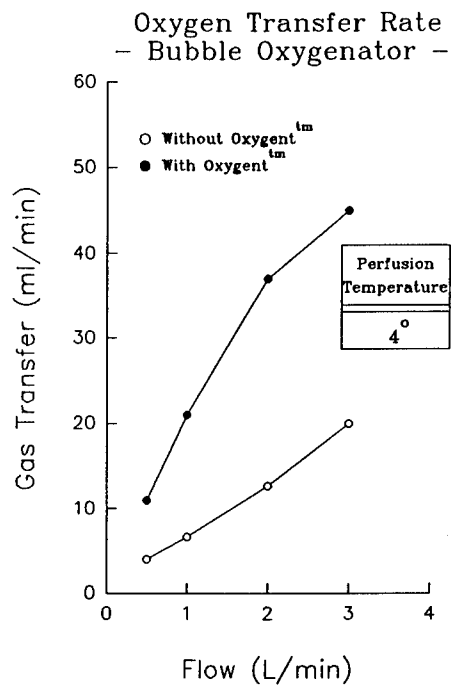

FIGURE 4: The oxygen transfer rate for a bubble oxygenator at a perfusion temperature of 4°C is shown.

oxygenators will provide the most efficient transfer of oxygen into a perfluorocarbon emulsion. Tests will also be run with blood-perfluorocarbon mixtures to assure that this difference is not limited to perfluorocarbon emulsions suspended in crystalloid solutions. If this preliminary inference is confirmed by further testing, then hollow fiber oxygenators will be used for studies to quantify the contribution of a perfluorocarbon emulsion to oxygen delivery during CPB in an animal model.

Other considerations that suggest the hollow fiber device is an appropriate choice include the following:

- 1) If O_2 transfer rates comparable to the hollow-fiber device could be achieved in a bubble oxygenator, they would probably require considerably higher O_2 flow rates to compensate for the relatively inefficient transfer of O_2 to perfluorocarbon from bubbles. This inference regarding bubble oxygenators is supported by data from a study of CPB with **Fluosol** [26]. Very high gas flow rates in a bubble oxygenator will: increase trauma to blood elements; increase

foaming of blood and the possibility of microbubble embolization; and may substantially increase the removal of CO₂ from the perfusate thereby causing respiratory alkalosis.

2) Membrane oxygenators have a sheet of silicone interposed between the fluid and gas phases. The data presented in this manuscript suggest that membrane oxygenators do not transfer O₂ as efficiently as the hollow-fiber device. Presumably design changes (e.g. a thinner membrane or more O₂ permeable material) will be necessary to achieve oxygenation comparable to the hollow-fiber device.

3) Important hypocarbia and alkalosis may result from an excessive transfer of CO₂ by perfluorocarbons. If this occurs, hollow-fiber devices (as well as membrane devices) are easily adapted to blenders that can add graded amounts of CO₂ to the sweep gas.

ACKNOWLEDGEMENT

I would like to thank the following people for their contributions to this work: Janice C. Cavin, Ph.D., David W. Kraus, Ph.D., Stephen M. Cain, Ph.D., Jefferson R. Dudelston, B.S.M.E., and Ron Brown, B.S. I would also like to thank Lynne Rich for her assistance in the preparation of this manuscript.

BIBLIOGRAPHY

1. JW Kirklin, BG Barratt-Boyes: Hypothermia, circulatory arrest, and cardiopulmonary bypass. In: Cardiac Surgery. Second Edition, New York, Churchill Livingstone Inc., p.78, (1993).
2. DL Bourke, TC Smith: Estimating allowable hemodilution. Anesthesiology 41:609-612, (1974).
3. M Mathru, B Kleinman, B Blakeman, D Dries, A Zecca, T Rao: Cardiovascular adjustments and gas exchange during extreme hemodilution in humans. Crit Care Med 19:700-704, (1991).
4. Y Kawashima, Z Yamamoto, H Manabe: Safe limits of hemodilution in cardiopulmonary bypass. Surgery 76:391-397, (1974).
5. JG Riess: Fluorocarbon-based in vivo oxygen transport and delivery systems. Vox Sang 61:225-239, (1991).
6. JG Riess, JL Dalfors, GK Hanna, MP Krafft, TJ Pelura, EG Schutt: Development of highly fluid, concentrated and stable fluorocarbon emulsions for diagnosis and therapy. Biomat Art Cells & Immob Biotech 20:839-842, (1992).
7. PE Keipert, S Faithfull, JD Bradley, DY Hazard, J Hogan, MS Levisetti, RM Peters: Oxygen delivery augmentation by low-dose perfluorochemical emulsion during profound normovolemic hemodilution. (In Press.) Oxygen Transport to Tissues XV. Vaupel, P (ed), Plenum Press, NY, (1993).

8. GP Biro, P Blais: Perfluorocarbon blood substitutes. *CRC Critical Reviews in Oncology/Hematology* 6:311-374, (1987).
9. GM Vercellotti, DE Hammerschmidt, PR Craddock, HS Jacob: Activation of plasma complement by perfluorocarbon artificial blood: Probable mechanism of adverse pulmonary reactions in treated patients and rationale for corticosteroid prophylaxis. *Blood* 59:1299-1304, (1982).
10. WL Holman, JK Kirklin: Cardiopulmonary bypass for cardiac surgery. In: Textbook of Surgery. DC Sabiston (ed.), Fourteenth Edition, Philadelphia, W. B. Saunders Company, pp. 2107-2110, (1991).
11. WJ Federspiel, AS Popel: A theoretical analysis of the effect of the particulate nature of blood on oxygen release in capillaries. *Microvasc Res* 32:164-189, (1986).
12. JD Hellums: The resistance to oxygen transport in the capillary relative to that in the surrounding tissue. *Microvasc Res* 13:131-136, (1977).
13. TEJ Gayeski and CR Honig: O₂ gradients from sarcolemma to cell interior in red muscle at maximal VO₂. *Am J Physio* 251:H789-H799, (1986).
14. NS Faithful and SM Cain: Critical levels of O₂ extraction following hemodilution with dextran and Fluosol-DA. *J Crit Care* 3:14-18, (1988).
15. RN Edie, SM Haubert, JR Malm: The use of haemodilution and a non-haemic prime for cardiopulmonary bypass. In: Techniques in Extracorporeal Circulation. MI Ionescu (ed.), Second Edition, London, Butterworth & Company, pp. 182-185, (1981).
16. FG Panico, WB Neptune: A mechanism to eliminate the donor blood prime from the pump-oxygenator. *Surgical Forum* 10:605-609, (1959).
17. DM Hirsch, Jr., C Hadidian, WE Neville: Oxygen consumption during cardiopulmonary bypass with large volume hemodilution. *J Thorac Cardiovasc Surg* 56:197-202, (1968).
18. FD Moore, KG Warner, S Assousa, CR Valeri, SF Khuri: The effects of complement activation during cardiopulmonary bypass. *Ann Surg* 208:95-103, (1988).
19. P Schupbach, E Pappova, J Kollar, P Sipos, D Vucic: Perfusate oncotic pressure during cardiopulmonary bypass. *Vox Sang* 35:332-344, (1978).
20. JR Utley, C Wachtel, RB Cain, EA Spaw, JC Collins, DB Stephens: Effect of hypothermia, hemodilution, and pump oxygenation on organ water content, blood flow and oxygen delivery, and renal function. *Ann Thorac Surg* 31:121-133, (1981).
21. J Niinikoski, V Laaksonen, O Meretoja, J Jalonen, MV Inberg: Oxygen transport to tissue under normovolemic moderate and extreme hemodilution during coronary bypass operation. *Ann Thorac Surg* 31:134-143, (1981).
22. J Brazier, N Cooper, JV Maloney, Jr., G Buckberg: The adequacy of myocardial oxygen delivery in acute normovolemic anemia. *Surgery* 75:508-516, (1974).

23. LH Kleinman, JW Yarbrough, JB Symmonds, AS Wechsler: Pressure-flow characteristics of the coronary collateral circulation during cardiopulmonary bypass. *J Thorac Cardiovasc Surg* 75:17-27, (1978).
24. SH Heimisch, H Meisner, R Erben, M Baum, N Mendler: The effect of hemodilution on regional myocardial function in the presence of coronary stenosis. *Basic Res Cardiol* 72:344-364, (1977).
25. W von Restorff, B Hofling: Effect of increased blood fluidity through hemodilution on coronary circulation at rest and during exercise in dogs. *Pflugers Arch* 375:15-24, (1975).
26. JA Rousou, RM Engelman, L Anisimowicz, WA Dobbs: A comparison of blood and Fluosol-DA for cardiopulmonary bypass. *J Cardiovasc Surg* 26:447-453, (1985).

FLUOROCARBON EMULSIONS - THE STABILITY ISSUE.

M. Postel¹, J.G. Riess¹ and J.G. Weers²

¹*Unité de Chimie Moléculaire, Associée au C.N.R.S., Université de Nice-Sophia
Antipolis, Parc Valrose, 06108 NICE Cedex 2, France,*

²*Alliance Pharmaceutical Corp., 3040 Science Park Road, San Diego, CA 92121,
USA*

ABSTRACT Long-term room temperature stability of ready-to-use concentrated fluorocarbon emulsions is necessary in order to fully exploit the therapeutic potential of fluorocarbons. Consequently, considerable efforts have been directed at investigating the physical nature of such emulsions, the mechanisms which lead to their degradation and the means of counteracting these. The particles which constitute typical fluorocarbon/egg yolk phospholipid emulsions have been identified to be surfactant-coated fluorocarbon droplets and lipid vesicles. Better understanding has been gained on the formation, structure and evolution of these particles during processing and storage. This has led to optimized formulations and processing, better control of emulsion characteristics and significantly improved stability. Molecular diffusion (Ostwald ripening or transcondensation) has been shown to be the main mechanism of degradation when particles are less than 1 μm in diameter, even for the highly concentrated (volume fraction of fluorocarbon up to 50%) second generation fluorocarbon emulsions. Significant emulsion stabilization has been accomplished by adding fluorochemicals which are both less volatile and less water soluble, *and* nevertheless have an organ dwell time acceptable for intravascular use. The rate of molecular diffusion can also be reduced by decreasing the fluorocarbon/water interfacial tension; this was effectively achieved with appropriate, well-defined fluorinated surfactants. A further, novel means of stabilizing fluorocarbon-in-water emulsions makes use of mixed fluorocarbon-hydrocarbon amphiphiles which act as molecular dowels to reinforce the adhesion between the fluorocarbon phase and the lipophilic zone of the surfactant film. Both long-term room temperature stability, and particle-size control over a large range of diameters, have been achieved by applying this principle. All in all it can be said that the challenge of producing injectable fluorocarbon emulsions with long-term room temperature particle size stability has been met.

INTRODUCTION

Stability is a primary requirement for fluorocarbon emulsions destined to be used as injectable oxygen carriers, contrast agents or drug delivery systems [1-2].

To stabilize an emulsion implies minimization of its free energy and creation of an effective energy barrier to oppose particle growth. Considerable efforts have been directed at investigating the formation and physical nature of fluorocarbon emulsions, the mechanisms which lead to their degradation and the means of counteracting these. This short review will discuss these studies and the improvements that they originated on the way to developing improved injectable fluorocarbon emulsions with long term shelf stability. The microemulsion approach, *i.e.* the spontaneous formation of thermodynamically stable microheterogeneous systems within a specific composition and temperature domain, and the difficulties inherent in this approach, will not be discussed here [3].

FROM FROZEN STORAGE TO LONG-TERM ROOM TEMPERATURE STABILITY

In 1989 the FDA licensed a first fluorocarbon emulsion, Fluosol[®] (Green Cross Corp., Osaka, Japan) as an oxygen carrier for use during the percutaneous transluminal coronary balloon angioplasty procedure [4]. Fluosol contains *ca* 14% w/v of perfluorodecalin (FDC) and *ca* 6% of perfluorotripropylamine (FTPA). The latter fluorocarbon was added as a stabilizer after an unsuccessful attempt at developing a stable FDC emulsion [5]. In spite of this, Fluosol comes as three distinct preparations, a frozen stem emulsion and two annex solutions from which the final injectable emulsion has to be reconstituted prior to use. As an additional disadvantage, the stabilizing additive, FTPA, has a prolonged retention time, $T_{1/2}$, in the reticuloendothelial system (RES) organs of 65 days, [6] related to its high molecular weight. Other first generation emulsions have been administered to humans: Emulsion n°II, which is manufactured in China [7] and is similar in composition to Fluosol, and Ftrosan or Perftoran (Russia) which contain the same amount of FDC but perfluoromethylcyclohexylpiperidine (PMCHP, $T_{1/2} > 60$ days)[8] as the stabilizing additive. The limitations of these emulsions are similar to those of Fluosol.

One major breakthrough in second generation perfluorochemical emulsions came with the development of concentrated stable emulsions trade-named Oxygent[™] and Imagent[®] (Alliance Pharmaceutical Corp., San Diego, USA). They are up

to five times more concentrated in fluorocarbon than Fluosol and have superior physical stability. They are heat sterilizable under standard conditions, no longer require to be frozen for shipment and storage, and are ready for use [9,10]. Perfluorooctyl bromide ($C_8F_{17}Br$, perflubron) is used as the fluorocarbon and egg yolk phospholipids (EYP) as the emulsifier. A four-year-old 100% w/v perflubron emulsion, which had been stored at 4-6°C and shipped twice across the Atlantic, when submitted to the drastic close-to-total isovolemic exchange perfusion of the conscious rat test, showed a survival ratio after a three-month observation period of 75%, comparable to that obtained with fresh emulsions [11].

EMULSION STABILITY

Impact of the preparation procedure

The characteristics and properties of emulsions, including their stability, depend not only on their formulation but also on the numerous parameters involved in their preparation procedure and on their history.

The influence of the conditions of preparation on the stability of concentrated fluorocarbon emulsions prepared with EYP has been shown [12]. This begins with the very first step of the preparation process, the dispersion of the water-insoluble phospholipids in the aqueous phase. Depending on the method used and energy applied, the phospholipid aggregates formed consist, as evidenced by transmission electron microscopy, of poorly organized "pre-liposomes", of multi-lamellar vesicles (MLV) or of small unilamellar vesicles (SUV). The emulsions prepared from the better organized MLVs or SUVs were significantly less stable than those prepared from poorly organized unclosed lipid layers (Figure 1). In the former cases a higher amount of fluorocarbon-free liposomes is left over, which has a detrimental effect on the emulsion's stability [13].

When emulsification itself is considered, high pressure mechanical procedures such as microfluidization or high pressure homogenization are superior to sonication, most likely as a result of narrower particle size distribution [14].

The dramatic effect of storage temperature on the stability of perflubron emulsion has been evaluated. The droplet growth rate of perflubron emulsion increases exponentially with temperature in the 5-40°C temperature range [15].

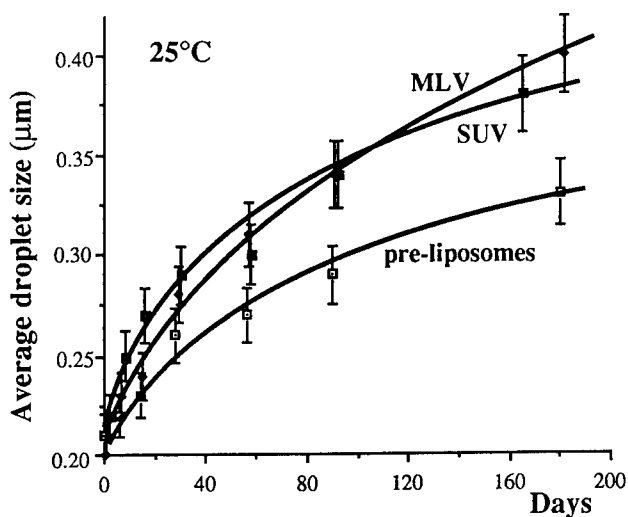

FIGURE 1 : Variation at 25°C of the average particle size of fluorocarbon droplets as a function of time in perflubron/EYP (90/4 %w/v) emulsions prepared from (a) "pre-liposomes"; (b) MLV; (c) SUV (from [12]).

Emulsion degradation upon storage

The fate of any emulsion is eventual phase separation. This can occur either through coalescence of the droplets, usually preceded by a flocculation (or aggregation) step, itself favored by creaming or sedimentation, or through molecular diffusion, the so-called Ostwald ripening process. Particle aggregation can be reversed by gentle agitation. On the other hand, coalescence and molecular diffusion are irreversible processes that eventually lead to complete phase separation [2].

Coalescence requires two droplets to come into contact and the subsequent thinning and disruption of the surfactant films which separate them. Emulsion degradation by coalescence is characterized by a widening of the particle size distribution. According to the coalescence theory of Van den Tempel, the cube of the mean particle radius, \bar{a}^3 , should increase exponentially with time (ideally, $\bar{a}^3 = \bar{a}_0^3 \exp(Kt)$ where a_0 is the radius at time zero and K is the coalescence constant).

Coarsening of an emulsion through molecular diffusion is due to the fact that the oil in small, submicronic droplets has a solubility in water greater than has

either the oil in larger ones or the bulk material. The pressure and chemical potential inside the droplets is inversely proportional to the droplet's radius, as seen from the Laplace equation. In terms of solubility the effect of the droplet's radius is given by $\ln(S_1/S_2) = \gamma_i V/RT (1/r_1 - 1/r_2)$, where S_1 and S_2 are the solubilities of the dispersed phase in particles of radius r_1 and r_2 respectively, V its molar volume, γ_i the interfacial tension, and R and T have their usual signification. This is a consequence of the Kelvin effect : the vapor pressure and the solubility in water of the dispersed liquid increase when the curvature of the droplets increases. As a result, individual molecules will tend to leave the smaller droplets, diffuse through the continuous phase and join the larger ones. In this isothermal distillation process the larger droplets will, therefore, grow at the expense of the smaller ones. This process does not require that droplets come into physical contact.

According to the Lifshits, Slezov, Wagner (LSW) theory [16,17], dispersed phase systems undergoing molecular diffusion can be characterized by a particle size distribution whose mean "number radius" cubed, \bar{a}^3 , increases linearly with time according to:

$$1/\tau = d(\bar{a}^3)/dt = 8CD\gamma_i V/9RT$$

where C and D are, respectively, the water solubility and diffusion coefficient of the dispersed phase in the continuous medium, V the molar volume of the dispersed substance (the fluorocarbon) and γ_i the interfacial tension between the dispersed (fluorocarbon) and continuous (water) phases. Another characteristic of molecular diffusion is that the distribution function for the ratio $\rho = a/\bar{a}$ of a particle radius, a , to the current mean number radius, \bar{a} , is time-invariant.

It has been recognized for some time that molecular diffusion (or Ostwald ripening) plays a decisive role in the coarsening of dilute fluorocarbon-in-water emulsions [18]. A linear increase in the volume of the droplets over time was first reported for F-decalin or F-tributylamine emulsions containing Proxanol P-268. Until recently, however, the reports were all related to emulsions in which the dispersed phase was rather dilute (volume fraction $\phi < 0.2$). Since the effective transport of adequate amounts of oxygen requires the development of considerably more concentrated injectable emulsions, it was necessary to verify whether or not molecular diffusion is still the primary degradation process in this case. In such emulsions the contacts between droplets are considerably increased, a situation which could indeed favor coalescence. Evidence has now been produced which shows that molecular diffusion is still the dominant mechanism of degradation for

highly concentrated (ϕ of *ca* 50%) fluorocarbon emulsions. The evolution of three perflubron/EYP/water emulsions with ϕ values of 0.01, 0.05 and 0.47, was found to be in accordance with the L-S theory : (i) the increase in volume of the particles is linear with time and the slope of the $\bar{a}^3 = f(t)$ curve, (*i.e.* the growth rate of the emulsion's particles) increases as expected [19] with ϕ , and (ii) there exist time-invariant distribution functions at any of the ϕ values examined [20]. Russian scientists showed in an elegant "reverse distillation" experiment that the degradation of fluorocarbon emulsions with both one and two component dispersed phases is well accounted for by the LSW theory [21]. Also convincing is a recent fluorocarbon emulsion transcondensation experiment in which 90% w/v concentrated emulsions [22] containing two homologous fluorocarbons with different water solubilities were analyzed at selected time intervals using sedimentation field-flow fractionation. This technique allows the separation and isolation of monosized particles for which the individual fluorocarbon content can then easily be determined. As predicted by the LSW theory, the small droplets were progressively enriched in the lower-water-solubility fluorocarbon while the larger droplets became enriched in the fluorocarbon with the higher water solubility.

Normally, the solubility of perfluorochemicals in water decreases when molecular volume, and hence usually molecular weight (MW), increase [23]. In agreement with the LSW theory, emulsion stability increases from FDC (MW = 462) to FTPA (MW = 521). F-44E produces more stable emulsions than FDC although the molecular weights of the two fluorocarbons are similar [24], presumably owing to the larger molecular volume of the former.

The LSW formalism is however incomplete, as it does not take into account the role and structure of the emulsifier film in the stabilization process, except for the interfacial tension term. Emulsifiers not only lower the interfacial tension at the fluorocarbon/water interface, thereby decreasing the free energy of the system, they also constitute the interfacial film which coats the individual droplets and prevents them from coalescing. The strength of this film, which is related to its viscous and elastic characters, is of key importance in opposing particle coalescence. Low interfacial tension alone does not guarantee emulsion stability. Some surfactants very effective in reducing fluorocarbon/water interfacial tension proved unable to assure emulsion stability [25].

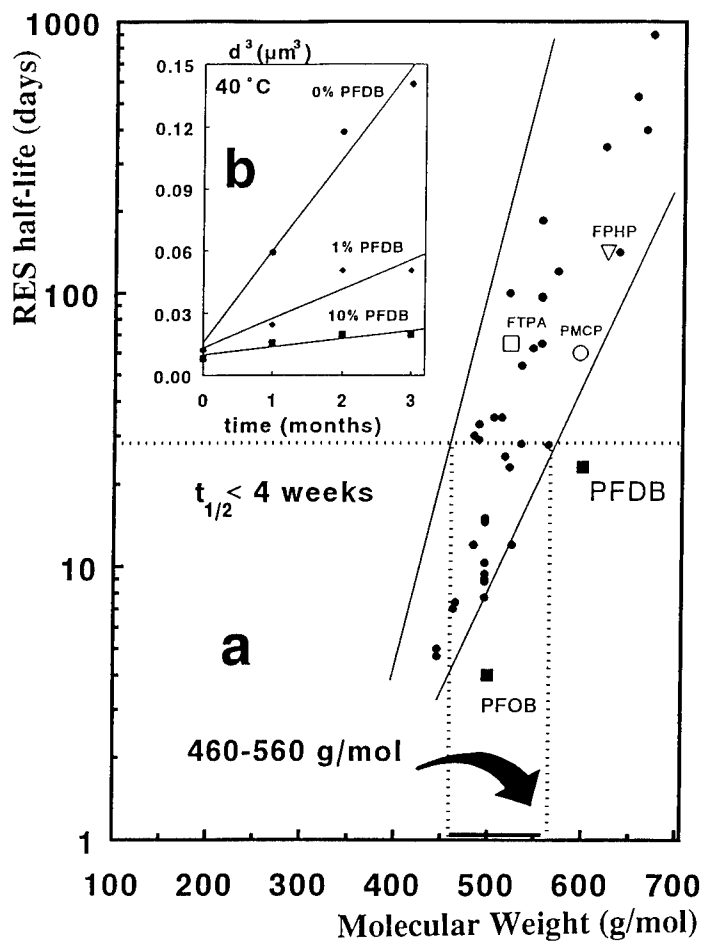

FIGURE 2 : a) Molecular weight dependance of the organ retention time of perfluorochemicals; the lipophilic $C_8F_{17}Br$ (PFOB perflubron) and $C_{10}F_{21}Br$ (PFDB) exhibit unusually low organ retention times relative to other perfluorochemicals; PPHP: perfluoroperhydrophenanthrene, FTPA: perfluorotripropylamine, PMCP: perfluoromethylcyclohexylpiperidine b) Stabilization of concentrated perflubron/EYP emulsions by a heavier fluorocarbon: perfluorodecyl bromide (PFDB); the particles' growth rates, at 40°C, are expressed as the increase in droplet volume per month.

EMULSION STABILIZATION

Fluorocarbon emulsions can be stabilized by decreasing the solubility of the dispersed phase in the continuous phase, by decreasing the interfacial tension and/or by improving the cohesive interactions at the fluorocarbon/surfactant/water interfaces.

Molecular diffusion suppression additives

One possible means of reducing Ostwald ripening in emulsions, is to add a small amount of a higher boiling point, poorly water-soluble material to the dispersed phase. Davis, early on, showed that increased stability is indeed conferred on FDC/Pluronic F108 emulsions (20/1 % w/v) by adding small quantities (1-5 % w/v) of perhydrofluoranthrene[26]. This principle is actually utilized in Fluosol and in Ftorosan or Perftosan with the addition of perfluorotripropylamine and perfluoromethylcyclohexylpiperidine, respectively, to FDC. The problem so far with these added components is that they have inacceptably long organ retention times. [1].

This approach has now been made practicable with the identification of stabilizing additives which have low vapour pressure and water solubility, and nevertheless also fast excretion rates. Figure 2 recalls that the excretion rates of "true" fluorocarbons are a steep, exponential function of the fluorocarbon's molecular weight [27]. Faster excretion is, however, achieved for fluorocarbons which have an exposed lipophilic substituant such as a bromine atom or an alkyl group. This is the case, in particular, for perfluorooctyl bromide, C₈F₁₇Br, and perfluorodecyl bromide, C₁₀F₂₁Br, for which the RES half-lives are only 4 and 23 days, respectively, i.e. much lower than what would be expected from their molecular weights only.

Advantage has been taken of such exceptions. Thus, the presence of 1% w/v of the heavier perfluorodecyl bromide in concentrated emulsions of the lighter perflubron or of perfluorodecalin already increases the emulsion's physical stability significantly (Figure 2b) [28]. An advantage of this approach is that the stabilizing additive is essentially of the same nature and biological compartment as the main fluorocarbon.

Fluorinated surfactants

Another way to retard Ostwald ripening is by means of better adapted surfactants. The surfactants currently used to prepare fluorocarbon emulsions,

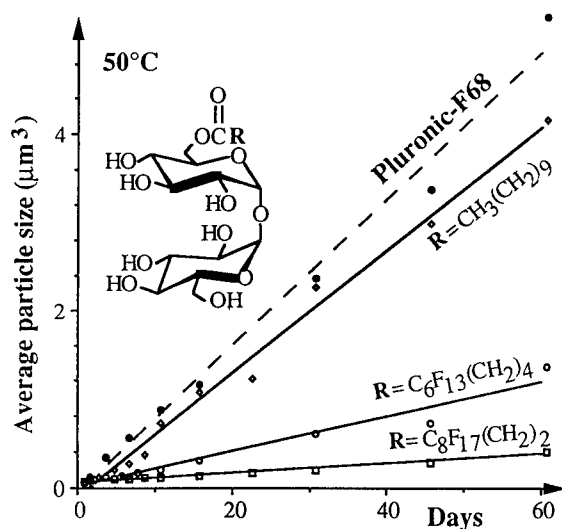

FIGURE 3 : Comparison of particle volume increase over time, at 50°C, of 50% w/v perfluorodecalin emulsions prepared with 5% of Pluronic F-68 or with 5% of a 1/1 mixture of Pluronic F-68 and of various hydrogenated or fluorinated fatty acid monoesters of trehalose.

Pluronic F-68 and natural egg yolk phospholipids, are not particularly fluorophilic, hence far from ideal when the "oil" to emulsify is a fluorocarbon. Highly fluorinated (fluorophilic) surfactants are much more effective in reducing the large interfacial tension that exists between fluorocarbons and water [2,27].

A range of new, highly fluorinated surfactants with single or double perfluoroalkylated hydrophobic chains has been developed, primarily for emulsifying fluorocarbons, but also to answer a more general need for highly effective, well-defined surfactants [29]. Very stable emulsions of FDC and perflubron were obtained with some of them. The neutral ones led to considerable synergistic stabilization when Pluronic F-68 was used as the primary surfactant, while anionic ones developed such synergistic effect with EYP [25]. An example of emulsion stabilization obtained with a fluorinated surfactant is given in Figure 3. Other examples can be found in ref [26]. However, little is known yet about the toxicity and pharmacodynamics of fluorinated surfactants [29].

The dowel approach

In a newer approach to emulsion stabilization, mixed fluorocarbon-hydrocarbon molecules, $R_F R_H$, are used to improve the cohesion between the fluorocarbon phase and an EYP [2,30] or Pluronic F-68 [31] surfactant film. In the former case the emulsions contain fluorocarbon droplets coated with a lipidic film. For each such droplet two interfaces can be considered : i) outwards, between the continuous water phase and the polar phosphocholine side of the EYP film and, ii), inwards, between the fatty acid chains of the EYP film and the fluorocarbon. It is the cohesion at the latter interface which needed improvement. It was our hypothesis that mixed fluorocarbon-hydrocarbon compounds, $R_F R_H$, could efficiently act as "*molecular dowels*" at the phospholipid/fluorocarbon interface and, consequently, improve the stability of the emulsions. The R_H segment of the dowels was expected to penetrate the fatty acid chain arrangement of the EYP film, while its R_F segment was expected to penetrate the fluorocarbon phase, thus achieving the sought-after improved adherence of the EYP coating to the fluorocarbon droplets.

Dramatic stabilization has indeed been obtained when small amounts (1 mole per mole of EYP) of such mixed $R_F R_H$ dowels, for example $C_8F_{17}CH=CHC_8H_{17}$ or $C_6F_{13}C_{10}H_{21}$, were incorporated in FDC, F-44E or perflubron emulsions formulated with egg-yolk phospholipids. The resulting emulsions are compared in Figure 4 in terms of particle size stability with reference emulsions prepared with EYP alone.

Preliminary biological evaluation in rats indicates that the dowel molecules themselves are biologically rather inert. No metabolism was found and the half-residence time in the liver of rats, after massive i.v. injection in emulsion form (3.6 g/Kg body weight), was of *ca* 25 days for a typical product, $C_6F_{13}CH=CHC_{10}H_{21}$ [32]. The absence of metabolism should greatly simplify the pharmacodynamic studies and acceptance of such compounds as stabilizers in a new generation of fluorocarbon emulsions for medical use.

Two mechanisms of action of the mixed fluorocarbon/hydrocarbon compounds were, a priori, to be considered. On the one hand, they could act as molecular diffusion-suppressing additives by reducing the water solubility of the fluorocarbon phase, on the other they could achieve the expected dowel effect at the interface. Of course both effects are possible and likely to contribute complementarily to emulsion stabilization.

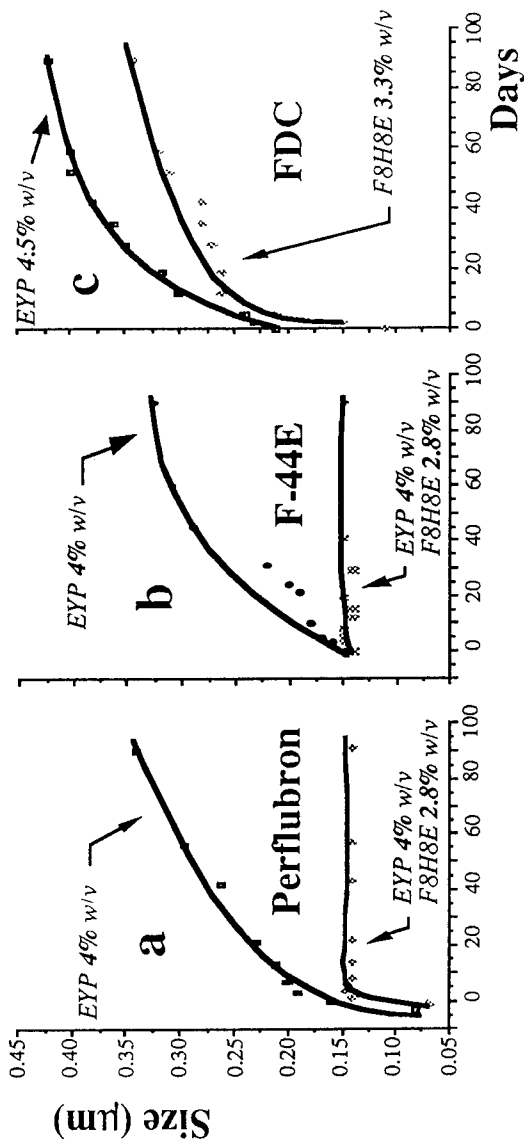

FIGURE 4 : Stabilization of concentrated perflubron/EYP emulsions by a molecular dowel, C₈F₁₇CH=CHC₈H₁₇ (F8H8E).

That the RFRH mixed compounds do not solely act as a low-water-solubility stabilizing additive is supported by the following results.

FDC/EYP emulsions with two different formulations, *i.e.* 100/4.5 % w/v and 50/3 % were prepared with F6H10E/EYP molar ratios of 1/5, 1/3, 1/1 and 2/1. These emulsions were more stable than a reference emulsion prepared without dowel. The emulsion's physical stability increased with the amount of RFRH (RFRH/EYP molar ratio going from 1/5 to 1/3 and 1/1). Most importantly, the emulsion's stability reached a maximum when the RFRH/EYP molar ratio was 1/1, after which it appeared to decrease again when more dowel (F6H10E/EYP molar ratio = 2/1) was included in the formulation [33]. That the efficacy of the dowel molecule reached a maximum strongly indicates that these molecules do not simply act as a low-water-solubility stabilizing additive, which would be dispersed throughout the fluorocarbon phase, but that they do play a role at the interface and interact with the lecithin molecules.

That structural effects do play a role in the stabilization of the emulsion is also illustrated in Figure 4 : the linear FnHm(E) molecular dowel was found to be significantly more effective in stabilizing emulsions when the fluorocarbon also was a linear molecule, e.g. perflubron or F-44E, than it was in the FDC emulsion, *i.e.* with a cyclic fluorocarbon.

Further evidence that the RFRH molecules have an action at the EYP/fluorocarbon interface was provided by tension measurements. Dynamic measurements demonstrated that the RFRH compounds strongly accelerate the absorption of EYP at this interface, while they have essentially no surfactant activity at the water/perflubron interface [34]. Most significant is the finding that the addition of the RFRH compounds modifies the surface occupied by a primary hydrophilic/lipophilic surfactant at the water/fluorocarbon interface. Thus, for example, the area occupied per molecule of C₁₁F₂₃COONa at the water/perflubron interface of $51 \pm 2 \text{ \AA}^2$ is reduced to $38 \pm 2 \text{ \AA}^2$ in the presence of the F4H10E molecular dowel.[34]

The use of dowels was also shown to allow the preparation of stable concentrated fluorocarbon emulsions with pre-selected particle sizes over a wide range of sizes (from *ca* 0.12 μm to *ca* 16 μm) [35]. It is noteworthy that the larger emulsions obtained ($>3.5 \mu\text{m}$) could not be prepared with EYP alone, *i.e.* without the dowel molecule. In such large ($> 1\mu\text{m}$) particle-size emulsions Ostwald ripening is no longer an effective degradation mechanism. Droplet coalescence

starts prevailing. The fact that minute amounts of molecular dowels stabilize such large particle-size emulsions further indicates that their action involves their presence at the interface.

CONCLUSIONS

Definite breakthroughs in terms of fluorocarbon emulsion particle size stability have been accomplished with the identification of efficient stabilizing additives. Perfluorodecyl bromide, a lipophilic high molecular weight fluorocarbon with acceptable RES retention times, stabilizes emulsions of lighter fluorocarbons (perflubron, perfluorodecalin) because it reduces fluorocarbon mass transfer in the aqueous phase. Some fluorinated surfactants allow the obtaining of very stable emulsions. The mixed hydrocarbon-fluorocarbon dowels stabilize fluorocarbon emulsions by reinforcing the binding between the fluorocarbon phase and the lipid layer of the surfactant membrane.

All in all it can be said that the challenge of producing injectable fluorocarbon emulsions with long-term particle-size stability has been met.

ACKNOWLEDGEMENTS : We wish to thank all those who collaborated in the work presented here and whose names appear in the references, as well as the Centre National de la Recherche Scientifique, ATTA and Alliance Pharmaceutical Corp. for their support.

REFERENCES

- (1). J.G. Riess. *Biomat., Art. Cells, Immob. Biotech.*, **20**, 183-204, (1992).
- (2). J.G. Riess and M. Postel, *Biomat., Art. Cells, Immob. Biotech.*, **20**, 819-830, (1992).
- (3). H.L. Rosano and W.E. Gerbacia, US Patent, 3,778,381 (1973) ; J.G. Riess, in "*Blood Compatible Materials and Devices*", Technomics Publ. C°, Lancaster, Pa, USA, Chap. **14**, 237-270 (1991) ; A. Lattes, *These Proceedings*.
- (4). Fluosol, Product Monograph, Alpha Therapeutic Corp., 1990.
- (5). R. Naito and K. Yokoyama, in "*Perfluorochemical Blood Substitutes*", the Green Cross Corp., Tech. Inform. Series n°5, p. 57 (1981).
- (6). K. Yamanouchi, M. Tanaka, Y. Tsuda, K. Yokoyama, S. Awazu, Y. Kobayashi, *Chem. Pharm. Bull.*, **33**, 1221-1231 (1985).
- (7). R. Xiong, R.A. Zhung, H.F. Chen, W.Y. Huang, C.P. Luo and W.T. Cao, *Chin. J. Surg.*, **19**, 213 (1981) ; H.S. Chen, Z.H. Yang et al., in "*Blood Substitutes*", TMS Chang and R.P. Geyer, eds, M. Dekker New York, 403-409 (1989).

- (8). F.F. Beloyartsev, E.I. Mayevsky, and B.I. Isianov, in "*Ftorosan. Oxygen Carrying Perfluorochemical Plasma Substitute*", Acad. Sci. USSR, Pushchino, 1983; Obratsov, *These Proceedings*.
- (9). D.C. Long, D.M. Long, J.G. Riess, R. Follana, A. Burgan and R.F. Mattrey, in "*Blood Substitutes*", T.M.S. Chang, R.P. Geyer, eds. M. Dekker, New York, 441-442 (1989).
- (10). J.G. Riess, J.L. Dalfors, G.K. Hanna, D.H. Klein, M.P. Krafft, T.J. Pelura and E.G. Schutt, *Biomat., Art. Cells, Immob Biotech.*, **20**, 839-842 (1992).
- (11). R. Follana, D.H. Klein, M.P. Krafft, D.M. Long, D.C. Long, Y. Ni, J.G. Riess and A. Valla, *Biomat., Art. Cells, Immob. Biotech.*, **20**, 1059-1062 (1992).
- (12). C. Cornelus, F. Giulieri, M.P. Krafft and J.G. Riess, *Colloids and Surfaces*, **70**, 233-238 (1993).
- (13). J.P. Rolland, M.P. Krafft, J.G. Riess, *J. Phys. Chem.*, **95**, 5673-5676 (1991) ; M. Postel, P. Chang, J.P. Rolland, M.P. Krafft and J.G. Riess, *Biochim. Biophys. Acta*, **1086**, 95-98 (1991).
- (14). J.G. Riess and M.P. Krafft, in *Oxygen Transport to Tissues XIV*, W. Erdmann, D.F. Bruley eds, Plenum Publ. Corp., New York, **317**, 465 (1992).
- (15). M.P. Krafft, M. Postel, J.G. Riess, Y. Ni, T.J. Pelura, G.Hanna and D. Song, *Biomat., Art. Cells, Immob. Biotech.*, **20**, 865-868 (1992).
- (16). I.M. Lifshits and V.V. Slesov, *J. Phys. Chem. Solids*, **19**, 35 (1961) ; L.C. Wagner, *Z. Elektrochemie*, **65**, 581 (1961).
- (17). P.W. Voorhees, *J. Stat. Phys.*, **38**, 231-252 (1985) ; A.S. Kabalnov and E.S. Shchuchkin, *Adv. Colloid Interf. Sci.*, **38**, 69 (1992).
- (18). S.S. Davis, H.P. Round and T.S. Purewal, *J. Colloid Interface Sci.*, **80**, 508-511 (1981) ; J.G. Riess, *Art. Org.*, **8**, 44 (1984) ; O.B. Pavlova-Verevkina, Yn.D. Aprosin, L.V. Novopashina and N.I. Afonin, *Kolloidh Zh.*, **49**, 178 (1987).
- (19). C. Varescon, A. Manfredi, M. Le Blanc and J.G. Riess, *J. Coll. Interface Sci.*, **137**, 373-379 (1990).
- (20). L. Trevino, L. Sole-Violan, P. Daumur, B. Devallez, M. Postel and J.G. Riess, *New J. Chem.*, **17**, 275-278 (1993).
- (21). A.S. Kabalnov, Yu D. Aprosin, O.B. Pavlova-Verevkina, A.V. Pertzov and E.D. Shchukin, *Kolloid Zh.*, **48**, 27-32 (1986).
- (22). B.A. Arlauskas, D.H. Klein and J.G. Weers, *These Proceedings*.
- (23). A.S. Kabalnov, K.N. Makarov and O.V. Shcherbakova, *J. Fluorine Chem.*, **50**, 271-284 (1990).
- (24). C. Varescon, C. Arlen, M. Le Blanc and J.G. Riess, *J. Chim. Phys.*, **86**, 2111-2117 (1989)
- (25). J.G. Riess, J. Greiner, S. Abouhilale and A. Milius, *Progr. Colloid Polym. Sci.*, **88**, 123-130 (1992).

- (26). S.K. Sharma, K.C. Lowe and S.S. Davis, in "*Blood Substitutes*", T.M.S. Chang, R.P. Geyer, eds. M. Dekker, New York, 447-450 (1989).
- (27). J.G. Riess, C. Arlen, J. Greiner, M. Le Blanc, A. Manfredi, S. Pace, C. Varescon and L. Zarif, in *Blood Substitutes*, TMS Chang, RP Geyer, eds, Marcel Dekker, New York, p. 421-430 (1989).
- (28). J.G. Weers, J. Liu, B.A. Arlauskas, P. Resch, T. Fields and J. Cavin, *These Proceedings*.
- (29). J. Greiner, J.G. Riess, and P. Vierling, in "*Organofluorine Compounds in Medicinal Chemistry and Biomedical Applications*", R. Filler, Y. Kobayashi, L.M. Yagupolskii eds, Elsevier, 339-380 (1993).
- (30). J.G. Riess, L. Sole-Violan and M. Postel, *J. Disp. Sci. and Technol.*, **13**, 349-355 (1992).
- (31). H. Meinert, R. Fackler, A. Knoblich, J. Mader, P. Reuter and W. Röhlke, *Biomat., Art. Cells, Immob. Biotech*, **20**, 95-113 (1992).
- (32). L. Zarif, L. Trevino, M. Postel and J.G. Riess, *Biomat., Art. Cells, Immob. Biotech.*, (in press).
- (33). L. Solé Violan, L. Trevino, B. Devallez, M. Postel and J.G. Riess, (unpublished)
- (34). L. Trévino, L. Solé Violan, F. Giuliéri, M. Postel and J.G. Riess, *2nd Colloque Français de Chimie du Fluor*, (Mèze, May 1993).
- (35). C. Cornelus, M.P. Krafft and J.G. Riess, *These Proceedings*.

**MICROEMULSIONS OF PERFLUORINATED AND
SEMI-FLUORINATED COMPOUNDS**

A. LATTES *, Ph.D. and **I. RICO-LATTES**, Ph.D.

Laboratoire des Interactions Moléculaires
et Réactivité Chimique et Photochimique
Université Paul Sabatier
118, route de Narbonne
31062 TOULOUSE, France

ABSTRACT - Perfluorocarbons combine high gas dissolving capacities with extreme chemical and biological inertness : they are good oxygen carriers in artificial blood and in liquid breathing. However fluorocarbons are highly hydrophobic molecules. To solve the problem of their transport, it is necessary to use the perfluorocarbons as an oil-in water emulsion (O/W). To avoid harsh treatment to form such emulsions and in order to have injectable "blood substitutes", microemulsions seem particularly attractive since they are fluid, transparent, thermodynamically stable microheterogeneous systems.

Microemulsions, contrarily to classical emulsions, are formed spontaneously by adding suitable surfactants (or a surfactant + a cosurfactant) in appropriate proportions to a non miscible mixture of water and oil.

Biocompatible O/W microemulsions are difficult to obtain because of :

- 1) the existing segregation between perfluorinated and hydrogenated chains, resulting, in some cases in heterogeneities or gelation phases ;
- 2) the toxicity of some components ;
- 3) the possible harmfulness of the dispersed system, etc...

We'll discuss all the parameters involved of the microemulsification process, the nature of products, the phase diagrams, and the phase behaviors. This study will outline certain guidelines necessary for the formation of microemulsions of perfluorinated (or almost completely fluorinated) oils with perfluorinated (or partially fluorinated) surfactants.

INTRODUCTION

The development of an artificial transporter of respiratory gases would be of great value. Fluorocarbons are the best gas solvents known, and they are also chemically and biologically stable. Aqueous emulsions of these compounds have thus been considered as potential blood substitutes for the transport of O_2/CO_2 . Such blood substitutes would also be of value for perfusion of isolated organs and in cell culture, etc.

A commonly used preparation is represented by Fluosol, an emulsion of F-decalin and Pluronic F68. However, it is rather unstable, and must be kept refrigerated [1]. Progress for elaborating fluorocarbons emulsions with improved oxygen capabilities have been recently obtained [2].

The use of oil in water microemulsions using perfluorinated oils would overcome the obstacle of instability. These microemulsions have the double advantage of forming spontaneously and remaining stable for periods of up to several years [3,4]. However, production of a microemulsion with a perfluorinated oil requires precautions due to segregation between the fluorinated and hydrogenated chains of components and also to inherent properties of microemulsions.

In this review we'll first describe the microemulsion systems, then we'll report our results concerning the physicochemical approach of microemulsification of perfluorinated compounds and, to finish, the main strategies to develop biocompatible microemulsions useful as blood substitutes.

Definition of microemulsions and differences from emulsions

There have been many definitions of microemulsions proposed, since there has not been universal agreement on just what constitutes such a system. We'll adopt the following: Microemulsions are fluid, transparent, and thermodynamically stable microheterogeneous systems which are formed spontaneously by adding suitable surfactants to an otherwise non-miscible mixture of water and oil (hydrocarbon, fluorocarbon, etc.). We can summarize the properties of emulsions and microemulsions in table I:

TABLE I : Comparison of emulsions and microemulsions

<u>Properties</u>	<u>Emulsions</u>	<u>Microemulsions</u>
composition	water, surfactant oil	water, surfactant (with or without <u>cosurfactant</u>), oil
Aspect	Turbid, milky	<u>clear</u>
Formation	with energy	<u>spontaneous</u>
Aggregates size	$d \leq 1 \mu\text{m}$	$d \leq 500 \text{ \AA}$
Behavior with time	decantation	<u>stable</u>

Formation of microemulsions

The consideration on microemulsions are based on the extensive studies of the phase diagrams of multicomponent systems represented by a tetrahedron in which each peak corresponds to one component of the system.

In order to facilitate the comprehension and the use of these diagrams, we make triangular sections of the tetrahedron, keeping constant the ratio surfactant/cosurfactant (or others ratios of two components) : Figure 2 shows the pseudo-ternary phase diagrams thus obtained [5]

By exploring the phase diagram we can distinguish essentially different areas : - normal micelles, for high content of water ; - reverse micelles, for high content of oil ; - lamellar phase, for high content of surfactant ; - bicontinuous structures, for solution containing roughly equal amounts of water and oil.

In order to obtain microemulsions of fluorocarbons useful as blood substitutes we must choose isotropic systems near the water top and to avoid the lamellar and bicontinuous structure on account of their potential high viscosity.

Unlike the hydrogenated systems, no systematic study of the formulation of fluorinated microemulsions has, to the authors' knowledge, been reported. This study of the microemulsification of various perfluorinated oils (or almost completely fluorinated oils) has been undertaken with different perfluorinated surfactants (or almost completely fluorinated surfactants) with or without a cosurfactant.

For the preliminary study, the biocompatibility of the surfactants and cosurfactants was not considered. The main purpose was to obtain microemulsions and to establish guide lines for the microemulsification of fluorinated compounds [6]. Starting from those results we'll discuss, in a second part, new formulations for blood substitutes.

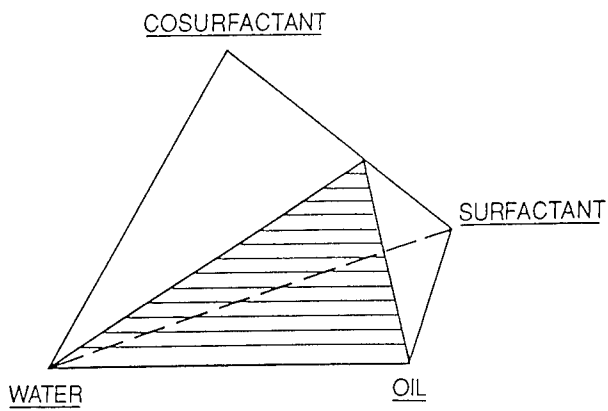

FIGURE 1 - Representation of a quaternary system

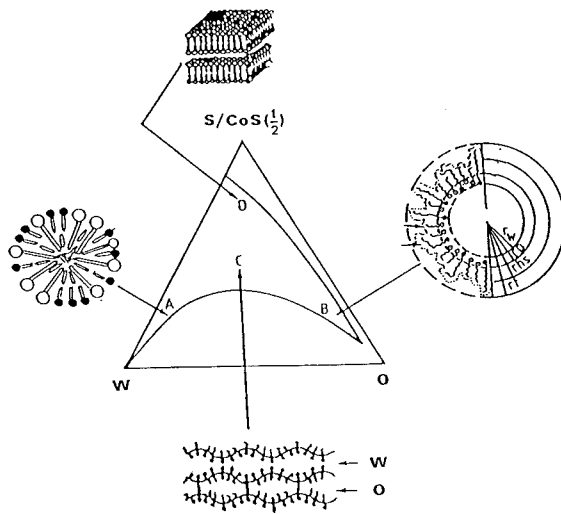

FIGURE 2 - Pseudoternary phase diagram

MATERIALS AND METHODS

Butan-1-ol (Prolabo) was used as supplied. Perfluoroalkanes and F-decalin were purchased from Fluka and were used as supplied. All other materials used in this study, were generously provided by ATOCHEM (PCUK) and were used as supplied. There was no indication in ^{19}F n.m.r. spectra of the presence of appreciable amounts of branched isomers.

Sodium pentadecafluorooctanoate ($\text{C}_7\text{F}_{15}\text{COONa}$) was prepared from the corresponding carboxylic acid (pentadecafluorooctanoic acid, PCUK). MONTANOX 80 was a generous gift of SEPPIC. The ternary or quaternary mixtures were prepared with doubly distilled water, at $25 \pm 0.1^\circ\text{C}$.

Synthesis of mixed oils

The mixed oils synthesized were of general formula $\text{R}_\text{F}-\text{CH}_2-\text{CH}=\text{CH}-\text{R}_\text{H}$.

A method for synthesizing compounds of this type developed in the laboratory, enabled the balance between the fluorinated and hydrogenated parts to be altered at will [7].

Pseudoternary phase diagrams

The limits of the phase regions have been determined for constant surfactant/cosurfactant (or surfactant/surfactant) weight ratios by titrating different mixtures of water and oil, or of surfactant, cosurfactant and oil with a defined solution of surfactant, cosurfactant and water, until a transparent homogeneous system was spontaneously obtained. Samples stored as microemulsions for a period of several months at room temperature, in sealed tubes, were found to be stable during this period. The diagrams have been drawn as usual in terms of weight percentages. The solubility of oxygen was measured with the Clark electrode.

RESULTS

Systematic study of microemulsification

Ternary Mixtures : one surfactant

The ternary phase diagram of the system $\text{C}_5\text{F}_{11}\text{COOH}/\text{C}_8\text{F}_{17}\text{C}_2\text{H}_5$ or F-decalin/ H_2O shows a large microemulsion area. But a transparent gel appears with F-decalin. It would appear that, in order to obtain a cosurfactant-free microemulsion, the surfactant must be both sufficiently hydrosoluble and liposoluble. Among the surfactants tested, only $\text{C}_5\text{F}_{11}\text{COOH}$ has this characteristic at room temperature.

Quaternary mixtures : one surfactant + one cosurfactant

With the amphiphilic mixture $\text{C}_8\text{F}_{17}\text{SO}_3\text{Li}/\text{C}_4\text{H}_9\text{OH}$, F-decalin and $\text{C}_8\text{H}_{17}\text{C}_2\text{H}_5$ give microemulsions systems essentially localized near the aqueous portion of the diagram. In all cases the largest single

monophasic area are obtained with surfactant/cosurfactant weight ratios = 2.

The maximum size of the microemulsion area is found with the oils $C_8F_{17}CH=CH_2$, $C_6F_{13}CH=CH_2$; $C_8F_{17}C_2H_5$. With $C_8F_{17}CH=CH_2$, $C_6F_{13}CH=CH_2$ and $C_8F_{17}C_2H_5$, the system $C_6F_{13}C_2H_4SO_3H$ /butan-1-ol (2/1) leads to smaller microemulsion areas than with the $C_8F_{17}C_2H_4SO_3H$ /butan-1-ol (2/1) system. This emphasizes the significance of the respective oil-surfactant chain lengths [8].

It is interesting to note that the diagrams carried out with butan-1-ol in this study are completely different from those with the butan-1-ol fluorinated homologue used by Oliveros et al. [9] : $C_3F_7CH_2OH$ is soluble in perfluorinated oils but not soluble in water and leads to W/O microemulsions whereas C_4F_9OH which is very slightly soluble in perfluorinated oils and soluble in water, does not.

The lack of microemulsions with $C_4F_9C_2H_4OH$ reconfirms the importance of the solubility of the cosurfactant : its too lipophilic nature thus prevents it from acting as a cosurfactant.

Quaternary mixtures : two surfactants

When the required HLB [10] of perfluorinated oils is respected, only the mixtures which have a sulphonate and a R_fCOOH carboxylic acid lead to the formation of microemulsions.

New Formulations for Blood Substitutes

Production of a microemulsion with a perfluorinated oil requires the use of a fluorinated surfactant due to segregation between the fluorinated and hydrogenated chains. Much effort is now being put into the development of non-toxic fluorinated surfactants. This approach can be summarized as :

The development of biocompatible fluorinated surfactants to microemulsify perfluorinated oils.

GERBACIA and ROSANO have described the first example of fluorocarbon dispersion by means of a volatile halogenofluorocarbon and a mixture of hydrogenated and fluorinated **nonionic surfactants** [11].

LANTZ et al. [12] have used the precedently described method with two surfactants : by using a mixture of polydisperse fluorinated poly(oxyethylene) compounds they obtained clear emulsions.

The first unambiguously study of nonionic microemulsions was realized by DELPUECH et al. [13]. Those authors obtained indefinitely stable microemulsions from a ternary mixture of water, fluorocarbon and a perfluoroalkyopoly(oxyethylene) surfactant of appropriate HLB the high content of oxygen dissolved in one such microemulsions

approaches the solubility in blood (20 vol. %). This work has opened a new way for obtaining a novel class of nonionic microemulsions possibly useful as blood substitute.

One of the last example of application of this method was the patent of YIV Seang [14] who, in 1990 described a microemulsion comprising a perfluorocarbon (perfluoromethyladamantane) dispersed in water with a non ionic surfactant.

In accordance with this strategy many new synthesis of non ionic fluorinated surfactants have been described [15].

In view of the above mentioned consideration, we felt that this approach was fraught with difficulties, and we opted for an approach which can be summarized as :

The adaptation of the oil to a known biocompatible surfactant.

At present, some hydrogenated non-ionic surfactants have been found to be biocompatible. We thus decided to synthesize and test mixed oils sufficiently fluorinated to dissolve gases and be eliminated rapidly, but sufficiently hydrogenated to enable them to be microemulsified using biocompatible hydrogenated surfactants [16].

Mixed oils and Selection of the olefin -The mixed oils synthesized were of general formula $R_F-CH_2-CH=CH-R_H$

The solubility of oxygen was used as a criterion for selection of the olefin for the preparation of the microemulsions [17].

The absorption of oxygen by F-decalin and mixed oils are shown in Table II.

The results indicate that the mixed oils 1 and 2 are good oxygen solvents : $C_8F_{17}-CH_2-CH=CH-C_4H_9$ is particularly interesting, since it has a larger fluorinated part than $C_4F_9-CH_2-CH=CH-C_8H_{17}$; the compounds 1 and 3 dissolve oxygen to as great an extent than F-decalin.

This shows the importance of steric factors in the solubility of oxygen in the fluorinated compounds. The double bond in the center of the molecule appears to lead to a steric hindrance that favors the dissolution of oxygen. $C_8F_{17}-CH_2-CH=CH-C_4H_9$ thus appears to be a viable alternative to F-decalin, the principal component of Fluosol.

Various microemulsions with $C_8F_{17}-CH_2-CH=CH-C_4H_9$ were produced, and all experiments were carried out at 37°C in order to approximate physiological conditions.

Microemulsions with $C_8F_{17}-CH_2-CH=CH-C_4H_9$

Ethoxy nonylphenols (NPn) of general formula $C_9H_{19}-C_6H_4-(OC_2H_4)_nOH$ are widely used in the production of microemulsions. In the range of compounds NP2 to NP15 only the NP14 derivative produced a monophasic zone with the mixed oil $C_8F_{17}-CH_2-CH=CH-C_4H_9$.

TABLE II - Absorption of oxygen in mixed oils
Compound N° Absorption
(ml/100 ml)

Compound	N°	Absorption (ml/100 ml)
C ₈ F ₁₇ -CH ₂ -CH=CH-C ₄ H ₉	1	43
C ₄ F ₉ -CH ₂ -CH=CH-C ₈ H ₁₇	2	31
C ₄ F ₉ -CH=CH-C ₄ F ₉	3	50
F-decalin	4	43

Microemulsion zone was observed in the water-rich region, making it suitable for intravenous administration. However, in view of the potential toxicity of this aromatic non-ionic surfactant (NP14) we investigated non-toxic analogues based on the HLB criteria (hydrophile-lipophile balance).

The HLB value can be determined experimentally or theoretically. The theoretical methods described by Griffin [18] and Davies [19] are commonly employed. Thus the HLB for NP14 is calculated to be 14.5. Surfactants with n HLB of around 14 were selected.

Montanox 80 is a non-ionic surfactant manufactured by Seppic with an HLB of 14. It has a very low toxicity (oral LD₅₀ > 16 ml/kg) and is used in the formulation of vaccines by the Institut Pasteur. It has the following formula :

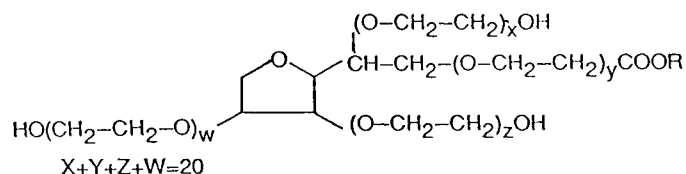

Montanox 80 produced a microemulsion zone similar to that obtained with ethoxy nonylphenol (NP14). The microemulsion zone is found in the water-rich region up to systems containing equal amounts of oil and water (point B) and with allow quantity of surfactant which would make it suitable for use in physiological conditions.

Four microemulsions were selected (points B, C, D and E in the phase diagram of Figure 3. Their compositions are shown in Table III.

It can seen that the microemulsions C, D and E have a viscosity close to that of water (1 cp), a further indication that they are rich in water (O/W type). However, microemulsion B which contains equal

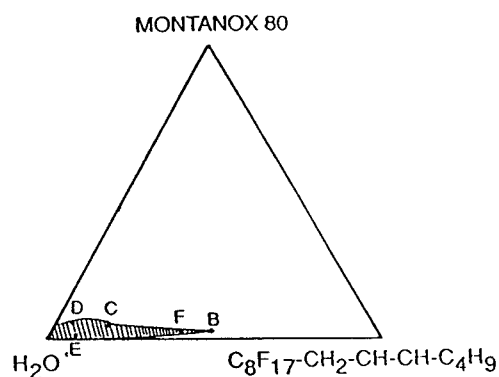

FIGURE 3 - Pseudoternary phase diagram of the system H₂O-Montanox 80
C₈F₁₇-CH₂-CH=CH-C₄H₉

TABLE III-. Characteristics of microemulsions B, C, D and E.

	Composition of microemulsions (% weight)					O ₂ absorption(ml/100ml)	
	Mx80	oil	H ₂ O	(cp)	r(Å)	Measured	Calculated
B	2.6	48.7	48.7	70.0	-	23	17.0
C	5.5	16.6	77.8	1.1	64	32	5.4
D	7.15	7.15	85.7	1.1	36	9	2.3
E	1.3	9.1	89.6	0.9	43	21	2.8

amounts of water and oil had a particularly high viscosity (70 cp) : it is probably a bicontinuous structure.

Physicochemical studies by quasi-elastic light scattering, showed that the microemulsions in the area rich in water are composed of small-sized aggregates of the oil in water type.

Measurements of the absorption of oxygen were carried out at 37°C with C₄F₉-CH=CH-C₄F₉ as reference as for the fluorinated oils. The results are summarized in Table III. These results showed that apart from microemulsion D, the others microemulsions dissolved oxygen to a greater extent than Fluosol-(7.5 ml O₂/100 ml) and, to a similar extent, to that of blood (20.6 ml O₂/100 ml).

It should also be noted that the theoretical values of oxygen solubility (taking into account the proportion of oil in the microemulsion) are much less than the measured values in microemulsions C, D and E which have a true micellar structure. The excess solubility was in fact > 500%. This would indicate that the structure of the microemulsion (presence of micellar cages) increases their capacity to take up oxygen. This phenomenon has been observed, albeit to a lesser extent (excess solubility of around 200%), with perhydrogenated microemulsion [20].

It should be emphasized that the presence of a fluorinated oil is required to observe this phenomenon of solubilization. The corresponding micellar solutions (without oil) only took up low proportions of oxygen (6 ml/100 ml). Moreover, the solubility of oxygen appeared to depend on the size of the micelles; the larger the micelles, the higher the solubility (cf. Table III).

Toxicology of the microemulsions

1 - Toxicity in Wistar rats after intraperitoneal administration.

We administered microemulsion F (57% water, 40% oil and 3% Montanox 80) at 5 g (of olefin)/kg body weight doses. Only slight alterations of biochemical parameters (albumin and calcium in both males and females, phosphorus γ -glutamyl transferase and iron in females only) were observed in some cases as elevations and in others as decreases with respect to control levels. These alterations were assumed to be of no toxicological significance [21].

2 - Toxicity in CDF1 mice after intravenous administration.

In order to prepare a solution suitable for intravenous administration (neutral pH, isotonic and isoionic), salts and glucose were added in the same proportions as those used in Fluosol. Since microemulsion E dissolved as much oxygen as blood we prepared an homologous microemulsion E' with the following characteristics :

TABLE IV - Characteristics of microemulsion E'

Composition (% weight)			Micelle radius	Measured oxygen absorption ml/100ml
Oil*	Mx80	Sterile Water Salts+glucose	43 Å	20
9.1	1.3	89.6		

*C₈F₁₇-CH₂-CH=CH-C₄H₉

It should be noted that the presence of the salts and glucose did not affect the size of the aggregates or the solubility of oxygen in the microemulsion.

Microemulsion E' had a pH of 7. None of the solutions were hemolytic and had the same behavior as the solutions of physiological saline (0.9% NaCl) used as controls. Microemulsion E' was thus injected into female CDF, female mice via the tail vein at various doses of olefin up to 2.3/kg body weight.

Body weight. The mice were weighed daily. Weight gain for treated and controls animals was not significantly different.

Autopsy. The mice were killed at different times after treatment. No macroscopic lesions were observed in any body organ. More detailed toxicological studies are in progress to investigate elimination of the constituents of this microemulsion.

DISCUSSION

This study has allowed certain guidelines necessary for the formulation of microemulsions of perfluorinated (or almost completely fluorinated) oils with perfluorinated (or partially fluorinated) surfactants to be established. To obtain a cosurfactant-free microemulsion, the surfactant must be sufficiently both hydro- and liposoluble.

The results also show that microemulsions can be produced using a partially fluorinated olefin and a biocompatible hydrogenated surfactant. The oil $C_8F_{17}-CH_2-CH=CH-C_4H_9$ was microemulsified using Montanox 80, a non-ionic surfactant.

Determination of the solubility of oxygen in these microemulsions showed that they absorbed larger amounts of oxygen than Fluosol which is widely used in biomedical applications. Oxygen absorption was in fact comparable to that of blood. Light scattering studies demonstrated the small size of their constituent aggregates.

The results after intraperitoneal injection in the rat indicated that these microemulsions are well tolerated. The isotonic preparations of neutral pH also appeared to be well tolerated after intravenous administration in mice.

REFERENCES

1. a) J.G. Riess and M. Leblanc, *Pure Appl. Chem.*, 54, 2383 (1982)
b) K. Yokoyama, K. Yamanouchi, T. Suyama, *Life Chem.*, 2, 35 (1983)
2. a) J.G. Riess, J.L. Dalfors, G.K.Hanna, D.H. Klein, M.P.Krafft, T.J. Pelura and E.G.Schutt, *Biomat. Art. Cells and Immob. Biotech.*, 20, 839 (1992)
b) J.G. Riess, In : *Blood Substitutes and Oxygen Carriers*, Chang TMS (ed), M. Dekker, New York, 24 (1993)
3. J.J. Delpuech, *La Recherche*, 16, 172 (1983)

4. G.Mathis, J.J. Delpuech, French Patent 8022 875 (1980)
5. M. Bourrel and R.S. Schechter, *Microemulsions and related systems*, Marcel Dekker, New York (1988)
6. C. Ceschin, J. Roques, M.C. Malet-Martino and A. Lattes, *J. Chem. Tech. Biotechnol.*, 35A, 73 (1985)
7. B. Escoula, I. Rico, J.P. Laval and A.Lattes, *Synth. Commun.*, 15, 35 (1985)
8. V.K. Bansal, D.O. Shah, *J. Colloid Interface Sci.*, 75, 461 (1980)
9. E. Oliveros, M.T. Maurette, A. Braun, *Helv. Chim. Acta.* 66, 1183 (1983)
10. I.J. Lin, *J. Phys. Chem.*, 76, 2019 (1972)
11. W. Gerbacia and H.L. Rosano, U.S. Patent 3 778 381 (1973)
12. P. Chabert, L. Foulletier, A. Lantz, French Patent 8 339 533 (1973)
13. G. Mathis, P. Lempoel, J.C. Ravey, C. Selve and J.J. Delpuech, *J. Am. Chem. Soc.*, 106, 6162 (1984)
14. Yiv Seang, European Patent, 391637 (1990)
15. A. Milius, J. Greiner and J.G. Riess, *New J. Chem.*, 15, 337 (1991)
16. C.Cecutti, I. Rico, A. Lattes, *J. Disp. Sci. Technol.*, 7(3), 307 (1986)
17. F. Meguro, H. Watanebe, H. Kato, K. Ogitarra and K. Esumi, *Bull. Chem. Soc. Jpn.*, 59, 386 (1983)
18. W.C. Griffin, *J. Soc. Cosmet. Chem.*, 5, 249 (1984)
19. J.T. Davies, *Proc. Int. Congr. Surface Activity*, London, 2, 426 (1957)
20. A. Berthod in *Microemulsion Systems* (H.L. Rosano and M. Clause, eds) Marcel Dekker, New York, 24, 319 (1987)
21. C. Cecutti, I. Rico, A. Lattes, A. Novelli, A. Rico, G. Marion, A. Graciaa and J. Lachaise, *Eur. J. Med. Chem.*, 24, 485 (1989)

FLUOROCARBON BLOOD SUBSTITUTES IN RUSSIA

Victor V. Obraztsov

Institute of Cell Biophysics, Russian Academy of Sciences,
Pushchino, Moscow Region, 142292 Russia

The large-scale investigation of fluorocarbon blood substitutes in the former USSR began in 1980 after the acceptance of the State Program entitled, "Perfluorocarbons in Biology and Medicine." As a result of this combined effort, the fluorocarbon emulsion Perftoran was created and clinical trials were started in 1984. Several hundred humans received Perftoran infusions under various clinical situations. Despite the favorable results of Perftoran treatment in general, the clinical trials were stopped in 1986 and renewed in September 1992. The data on Perftoran clinical trials, as well as the advantages and shortcomings of the emulsion, have been analyzed.

Attempts to make a blood substitute based on a fluorocarbon emulsion were performed in Russia just after the publication of well-known articles [1,2]. Creation of such a blood substitute was quite successful because first, the industrial production of fluorocarbons was organized in the ex-USSR at that time; and second, a strong scientific school of fluorine chemistry existed, headed by academician Ivan Knunjants. All of the previous studies of fluorocarbon blood substitutes were carried out under the control of the Ministry of Defense. Practically nothing is known about work accomplished during those years. In the late seventies, the obvious success of western scientists (first of all, the beginning of clinical trials of Japan's Fluosol DA [3]) stimulated an interest in the problem not only on the part of military physicians, but also in the broad circles of the Academy of Sciences, the Academy of Medical Sciences, the Ministry of Health Protection, and the Ministry of Medical Industry. In 1980, the All-State Scientific-Technical Program, "Perfluorocarbon in Biology and Medicine" was adopted [4]. The

TABLE I. Fluorocarbon Blood Substitutes Which Obtained Permission for Clinical Trial in 1984 [5,6].

Name Producer	Perftoran (Ftorosan) Institute of Biological Physics, Acad. Sci. USSR Pushchino	Perfukol Institute of Hemathology and Blood Transfusion Moscow
<u>Constituents</u>	<u>Percent (w/v)</u>	<u>Percent (w/v)</u>
Perfluorodecalin (PFD)	13	35
Perfluoromethylcyclo- hexylpiperidine (PFMCP)	6.5	—
Perfluorotripropylamine (PFTPA)	—	15
Proxanol 268	4	2.6
Egg Yolk Phospholipids	—	0.7
Sorbitol	—	3.4
Glucose	0.2	—
Sodium chloride	0.60	—
Potassium chloride	0.039	—
Magnesium chloride	0.019	—
Sodium hydrophosphate	0.02	—
Sodium bicarbonate	0.13	—
Mean particle diameter	70-120 nm	180 nm

head of the program was academician Ivan Knunjants, professor Filex Beloartsev was secretary (more exactly, soul and vigor), and more than 40 institutions participated. Many investigations were carried out, but the main achievements of the Program were the following:

- the start of industrial production of PFCs, satisfying biomedical demands
- manufacture of extrusion disintegrators "Donor-1," suitable for semi-industrial production of fluorocarbon emulsions
- creation of semi-industrial technology for the preparation of sterile and apyrogenic blood substitutes on the basis of fluorocarbon emulsions.

The main result of the Program in the USSR was the creation of two fluorocarbon blood substitutes that received official permission for clinical trials (Table I).

It should be stressed that the Perfukol emulsion, in spite of the positive results of pre-clinical tests, has been discovered not to be suitable for injection into humans. It caused severe reactions, among them pyrogenic reactions; consequently, its clinical trials

were stopped. The emulsion Perftoran has withstood the test more successfully. The institutions listed below show where clinical trials have been carried out since 1984.

TABLE II. Institutions Participating in the Perftoran Clinical Trials

Institution	Number of Patients
Burdenko's Main Military Clinical Hospital, Moscow	234
Wishnevsky's Institute of Surgery, Moscow	45
Medical Institute, Dnepropetrovsk, Ukraine	27
Institute of Neurosurgery, Kiev, Ukraine	26
Institute of Transplantation and Artificial Organs, Moscow	26
Department of Children Surgery, 2nd Moscow Medical Institute	no data
Institute of Hyperbaric Oxygenation, Moscow	no data

Before reviewing the results of Perftoran clinical trials, it is necessary to stress that, first, only published data will be analyzed here and, second, the data presented are incomplete because of the USSR Ministry of Health Protection's former ban on publication of results from clinical trials of new drugs.

The Military Hospital has extensive experience with the clinical application of Perftoran (including use of the blood substitute during the military activity in Afghanistan) [7]. Consequences of Perftoran use were acute massive blood loss, extreme shock as a result of polytrauma, alterations of microcirculation, gas exchange and metabolism in tissues as a result of serious chronic diseases, and postoperative hypovolemia. The Perftoran dose was about 6-80 ml/kg. The injection was followed by respiration of an air-oxygen mixture with $FiO_2=0.6$. The estimation of Perftoran's reactogenicity (ability to provoke transient acute reaction at very low doses of the emulsion in some patients) is an important result of the numerous tests completed in the Military Hospital.

TABLE III. Perftoran Side-Effects in Conscious Patients (n=43).

Enhancement of intestinal peristalsis	26
Heartburn	3
Sense of increased awareness	12
Body temperature raised by 0.6°C	5
Cough	3
Hyperemia of skin	4
Pain in the small of the back	5
Acute pain behind the breastbone	2

As a rule, the reactions were expressed weakly and ceased spontaneously after stopping the infusion. After the reactions disappeared, Perftoran was reinfused. In two cases the reaction to the Perftoran test-dose was extremely severe and was accompanied by the decline of arterial pressure and bradycardia. In these cases the infusion was stopped and the patients had to be injected with corticosteroids and ephedrine. The physicians of the Hospital made the following conclusions based on the trials:

1. Hemodynamic and anti-shock effects are more prominent with Perftoran than with traditional plasma substitutes.
2. Perftoran improves tissue oxygenation and normalizes tissue metabolism.
3. Application of Perftoran reduces (by 40-60%) the expense of donor blood necessary for restoration of central hemodynamics, peripheral blood flow and adequate tissue perfusion.
4. There are no contraindicated conditions for the use of Perftoran, especially in critical situations.

Fluorocarbon emulsions were tested as a medicine for myocardial protection against hypoxia during artificial valve implantations at the Department of Acquired Valvular Diseases, A. V. Vishnevsky's Institute of Surgery, Moscow [8,9]. Constant perfusion of coronary arteries with oxygenated PFC emulsion under perfusion pressure (40-50 mmHg) was used for 28 patients. Seventeen patients received a single injection of 1.5 L oxygenated PFC emulsion in the coronary arteries (cardioplegia). Operations were made under hypothermia (12-19°C); time of the aorta clamping was 20-120 min. Experimental and clinical studies in this field found a number of advantages of the fluorocarbon-containing solutions in comparison with traditional perfusion and cardioplegia solutions [8-10]:

- increases oxygen supply to the myocardium
- delays development of ischemic contracture 2-fold
- reduces and stabilizes the depolarization of heart cell membranes
- supports a comparatively high heat production
- lessens reduction of myocardial pH
- slows down the development of edema
- eliminates the danger of heart rhythm failure
- decreases coronary resistance
- diminishes reperfusional/reoxygenative damage

- creates additional relaxation of the heart, facilitating the surgeon's work
- reduces the injurious effect of endogenic catecholamines at the beginning of cardioplegia and during reperfusion

Attempts to use Perftoran during kidney transplantation have been undertaken [11]. It should be noted that these trials were conducted more accurately and the results were described in detail. The physicians of the Institute of Transplantation and Artificial Organs, Moscow, made the donor kidney withdrawal under the protection of the emulsion. Kidney withdrawal from a donor corpse included the following stages:

- infusion of 1.2-1.6 L of Perftoran 1.5-2.0 hrs before heart stoppage
- 1 h lung ventilation by 100% oxygen, then 0.5 h by 50% oxygen
- kidney isolation
- kidney bathing with Collin's solution
- storage of kidneys at 0-2°C during 9-12 hrs without any perfusion
- transplantation

TABLE IV. Functions of the Transplanted Kidney After 1 Year (n=38).

Characteristic	Control	Perftoran
Urination during 1 h after transplant	55%	100%
Tubular acute necrosis	45%	24%
Deleted transplants	45%	24%
Working transplants	35%	60%
Lethality of patients	40%	20%

Perftoran was also used for the treatment of 26 neurosurgery patients with acute hypoxic syndrome (Institute of Neurosurgery, Kiev, Ukraine) [12]. The indications for Perftoran administration were acute respiratory failure, chronic heart-lung failure, acute renal failure, and brain tumors with intracranial hypertension. It should be noted that Perftoran was applied after unsuccessful traditional treatment. The Kiev neurosurgeons have found improvement of clinical and biochemical indicants of the patients. Side-effects and adverse reactions were not observed during the Perftoran administration.

A promising result of the emulsion treatment of 15 acute skull-brain traumas was obtained by physicians from the Medical Institute (Dnepropetrovsk, Ukraine) [13]. They used the following scheme of the treatment:

- administration of oxygenated Perftoran at a dose of 5-7 ml/kg

- injection of sodium oxybate and thiobarbiturates
- hyperbaric oxygenation (7-10 times, 1.2-1.5, at 60-90 min.)

A number of conclusions were made by Dnepropetrovsk's physicians after Perftoran application:

1. Perftoran has favorable influences on gas transport and rheology of blood.
2. Perftoran improves the biochemical and neurologic indicants of the brain and the whole organism.
3. The emulsion decreases blood trombogenicity that could cause hemorrhage of injured vessels.
4. It is not necessary to use special equipment and conditions during infusion of Perftoran.

The general opinion of the physicians participating in the trials of 1984-1986 is that Perftoran is a unique preparation that may be applied in the following clinical situations [6]:

- acute and chronic hypovolemia (shock, trauma)
- alterations of microcirculation and peripheral circulation
- alterations of tissue metabolism and gas exchange
- donor organ protection
- cardioplegia
- regional perfusion and lavage

Analyzing the high therapeutic efficacy of the Perftoran emulsion, it should be noted that this blood substitute is 10% vol/vol fluorocarbon emulsion and stabilized by 4% Proxanol 268 (the analog of Pluronic F68). It is well known that Pluronic F68, injected into blood vessels in a comparatively low dose, demonstrates various effects which could be considered as positive [14]. Pluronic F68 decreases blood viscosity, improves microcirculation, increases arterial pressure and diuresis, supports oncotic pressure of blood, inhibits development of fat emboli, activates or inhibits various enzymes, interacts with biological membranes, increases osmotic resistance of RBCs, inhibits aggregation of blood cells and affects ion channels of biological membranes. Thus, one can conclude that some positive properties of Perftoran are due to the high concentration of Proxanol 268 in the emulsion.

The other distinctions of Perftoran are, first, the small mean particle diameter of the emulsion (close to 70-80nm) and, second, the fluorocarbon phase of the emulsion is

a mixture of PFD and PFMCP. The latter is a slowly expired PFC with a relatively low vapor pressure (2 mm Hg) and a critical dissolution temperature of 40°C in hexene.

The composition of the emulsion determines its shortcomings. Perftoran has a low stability; it can be stored for 2 weeks at 4°C or 1 year at -20°C. Other shortcomings are the impossibility of heat sterilization, the absence of an oncotic agent, and blood complement activation. However, the reasons for the temporary stopping of Perftoran clinical trials in 1986 were not the above-enumerated shortcomings of the blood substitute. The reasons were reported elsewhere [15]. After the stopping of the Perftoran clinical tests, work in the field of fluorocarbon blood substitutes was continued in the following areas:

In the field of safety of the blood substitutes:

- finishing of extensive trials of Perftoran carcinogenicity, having shown an absence of carcinogenic properties of the emulsion
- proof of Perftoran's harmlessness not only by physicians, but also by inspectors of USSR General Procurator's Office and Committee of State Security (K.G.B.).

In the field of technology:

- synthesis of new fluorocarbons for biomedical purposes, including perfluorooctylbromide
- preparation of concentrated fluorocarbon emulsions stabilized by phospholipids
- organization of an experimental factory with an output about 1000L of Perftoran per year

In the field of investigations of emulsion properties:

- studying of biological effects of Proxanols
- experimental analysis of emulsion effects that were discovered during clinical trials
- studies of fluorocarbon emulsion stability
- activation of liver microsome enzymes by perfluorochemicals
- reactogenicity of fluorocarbon emulsions stabilized by Proxanols

Concerning fluorocarbon blood substitutes in Russia today, it may be noted that "Perftoran" Pharm. Comp., Pushchino produces the blood substitute Perftoran. Clinical trails started in September 1992 and are being continued at the present time [6]. Over 100 patients were infused with the new Perftoran emulsion since September 1992. A decrease in the homogenization pressure during preparation of the emulsion, as well as application

of the netropenic test of Perftoran before its use in clinics, provided the absence of any adverse reactions in the patients after the blood substitute infusion [6, 16].

"Nizar" Pharm. Comp., Moscow produces and sells various fluorocarbon emulsions for use as a component of cosmetics and therapeutic ointments [17].

Some scientific-technical programs (both state and private) concerning fluorocarbon blood substitutes are being formed now in Russia. However, taking into account that the blood substitute problem is national, one can understand that the further progress of fluorocarbon blood substitutes in Russia will depend on the political and economic situation of the country. In any case, Russia still has a considerable potential to produce various fluorocarbon blood substitutes.

REFERENCES

1. L.C. Clark, F. Gollan. *Science* 152, 1755-1756 (1966).
2. R.P. Geyer. *Fed. Proc.*, 34, 1499-1505 (1975).
3. T. Mitsuno, H. Ohyanagi, R. Naito, *Ann. Surg.*, 195, 60 (1982).
4. G.R. Ivanitsky, F.F. Beloyartsev. In: *Medico-Biological Aspects of Application of Perfluorocarbon Emulsions*. ONTI NCBI, Pushchino, 9-39 (1983).
5. F.F. Beloyartsev, E.I. Mayevsky, B.I. Islamov, *Information: Ftorosan Oxygen Carrying Perfluorochemical Plasma Substitute*. Acad. Sci. USSR, Pushchino (1983).
6. S.I. Vorob'ev et al. *Perfluorocarbon Emulsions*. Tech. Inform. Perftoran Pharm. Comp., Pushchino (1993).
7. N.L. Krylov, V.V. Moroz, F.F. Beloyartsev. *Voenno-Meditsinsky Surnal*. No 8, 36-40 (1985).
8. M.I. Kuzin, F.F. Beloyartsev, A.N. Kaydash, B.I. Islamov, A.L. Tverskoy, V.A. Janin. In: *Medico-Biological Aspects of Application of Perfluorocarbon Emulsions*. ONTI NCBI, Pushchino, 102-116 (1983).
9. F.F. Beloyartsev, A.N. Kaydash, B.I. Islamov, E.I. Maevsky, A.L. Tverskoy, N.V. Shibaev, V.N. Luchitsky, E.M. Kobrinsky. In: *Medico-Biological Aspects of Application of Perfluorocarbon Emulsions*. ONTI NCBI, Pushchino, 116-127 (1983).
10. F.F. Beloyartsev, B.I. Islamov, E.I. Mayevsky. *Information: Perfusion and Nonperfusion Methods of Myocardial Protection with Perfluorocarbon Emulsion*. Acad. Sci. USSR, Pushchino (1983).

11. V.I. Shumakov, N.A. Onishchenko, S.I. Vorob'ev, G.R. Ivanitsky. In: Perfluorocarbon Emulsions. ONTI NCBI, Pushchino (1993, in press).
12. M.I. Dolgova, S.A. Romodanov, R.M. Trosh. In: Perfluorocarbon Emulsions. ONTI NCBI, Pushchino (1993, in press).
13. L.V. Usenko, E.N. Kligunenko. In: Perfluorocarbon Emulsions. ONTI NCBI, Pushchino (1993, in press).
14. V.V. Obratsov, V.V. Ponomarchuk. *Khimiko-Farmatsevt.Zhurnal*. No 1, 23-27 (1988).
15. V. Rich. *Nature*, 335, 107 (1988).
16. V.V. Moroz. (personal communication).
17. O.E. Oxinoic, D.P. Sydlyarov, Yu.D. Aprosin, V.V. Obratsov. *Biomat.Artif.Cell Immobil.Biotech*. (1993, in press).

QUANTITATIVE PO₂ IMAGING IN VIVO WITH PERFLUOROCARBON
F-19 NMR: TRACKING OXYGEN FROM THE AIRWAY THROUGH
THE BLOOD TO ORGAN TISSUES

S.R. Thomas¹, R.W. Millard², R.G. Pratt¹,

Y. Shiferaw¹, and R.C. Samaratunga¹

Departments of Radiology¹ and Pharmacology & Cell Biophysics²

University of Cincinnati, Cincinnati, Ohio USA 45267-0579

ABSTRACT

The physiological redistribution of perfluorocarbon (PFC) compounds to liver, spleen, bone marrow, and lung after intravenous (IV) or intraperitoneal (IP) administration of PFC emulsions affords the unique opportunity for non-invasive monitoring of oxygenation status of these organs and tissues utilizing fluorine (F-19) nuclear magnetic resonance (NMR) imaging techniques. PFCs also may be introduced directly into the pulmonary airways by procedures such as liquid ventilation, intratracheal instillation, or aerosol inhalation. Considerations of importance when establishing methodology for accurate quantitation of oxygen partial pressure (pO₂) in vivo using F-19 NMR include: 1.) error analysis of the calibration curves which relate pO₂ to the measured PFC F-19 relaxation rate, 2.) optimization of the NMR pulse sequence for efficient oxygen sensitive data acquisition and, 3.) fluorine signal independence from emulsion aqueous phase bioconstituents. The porcine model was investigated at 0.14T following IV or IP administration of the PFC emulsion containing perfluorotributylamine (FC-43) to demonstrate the capability for tracking oxygen with F-19 NMR from the lung through the blood to selected organ tissues. Quantitative pO₂ projection images and isobaric contour graphs were derived for the liver, spleen, and lungs as a function of inspired oxygen. Blood pO₂ levels in aorta, pulmonary artery, and hepatic vein were monitored simultaneously with NMR imaging for correlative analysis.

INTRODUCTION

The potential for *in vivo* oxygen sensitive imaging and quantitation of pO_2 in blood, organs, tissues, and other anatomic spaces containing perfluorocarbon (PFC) compounds utilizing F-19 NMR techniques as based on the paramagnetic effect of dissolved oxygen which reduces the F-19 spin-lattice relaxation parameter (T1) has been investigated extensively [1-7]. (Note: Conceptually similar spin-spin relaxation (T2) based techniques for monitoring pO_2 will not be addressed in this manuscript [3].) One of our long-term research objectives is to establish efficacious, non-invasive F-19 NMR methodology for accurate quantitation of oxygen tension *in vivo* with clinically practical levels of PFC blood substitute emulsions. This paper illustrates the utility of calculated pO_2 images in assessing regional oxygenation status and physiologic viability of organs and tissues. A porcine model is used to demonstrate the comprehensive capability for tracking oxygen distribution with F-19 NMR from the lungs through the blood to organ tissues sequestering PFCs.

MATERIALS AND METHODS

Oxygen Enhanced Imaging: Paramagnetic agents which reduce T1 may be used to enhance the NMR signal under T1 sensitive data acquisition protocols. Thus, anatomic regions accumulating the agents gain contrast relative to adjacent non-accumulating tissue and appear brighter in the MR image. The intrinsic paramagnetic property of molecular oxygen coupled with its high solubility in fluorocarbons may be utilized to provide oxygen enhanced imaging of sites containing the PFCs through reduction of the fluorocarbon phase T1. Figure 1 provides a qualitative illustration of this signal enhancement [8].

Calculated pO_2 Images: The desired endpoint is to derive a quantitative pO_2 image or map which provides direct readout in partial pressure of oxygen (e.g., pO_2 in torr). The first step entails F-19 data acquisition under a T1 sensitive NMR pulse protocol as required for producing a calculated T1 image (see below). In this process, a fluorine distribution image also may be obtained with regional intensity related to the fluorine (PFC) concentration as well as to pO_2 (Figure 1b). Most PFC NMR spectra exhibit multiple lines of varying intensity as a result of non-equivalent chemical environments of the individual fluorine atoms within a given molecule. Our experimental protocol involves acquisition of this entire spectrum with application of computerized deconvolution algorithms allowing improved

signal-to-noise characteristics and image reconstruction free of interfering chemical shift artifacts [9,10]. A calculated T1 image is obtained after appropriate computer processing of the T1 encoded F-19 data. The next step is to transform the calculated T1 image into the desired pO₂ map. The linear relationship between the longitudinal relaxation rate 1/T1 and pO₂ has been well established [1,11,12]. This linear correlation which depends upon the specific PFC, temperature, and magnetic field strength defines a calibration curve relating measured T1 values to pO₂ (see Figure 2). Thus, application of the appropriate calibration function to the calculated T1 data set yields the desired pO₂ image (Figure 1c, d).

Determination of the uncertainty associated with the calculated pO₂ values is of critical importance. Under the assumption that the selected calibration curve is appropriate for the physiological temperature of the imaged organ(s), the main source of error involves accuracy of the calculated T1 values. We conservatively estimate the T1 uncertainty to be $\pm 5\%$ for our system operating at 0.14T. Detailed error propagation analysis for the perfluorotributylamine (FC-43) (Figure 2) and perfluorooctylbromide (perflubron or PFOB) calibration curves under this constraint was used to characterize the uncertainty in pO₂. The uncertainty (a function of pO₂) was found to range from ± 9 to ± 16 torr for FC-43 and ± 3 to ± 11 torr for PFOB when increasing the pO₂ from 1 to 150 torr. An accuracy of ± 5 torr in the physiologically relevant pO₂ range is predicted. Higher magnetic field strength may succeed in narrowing these confidence limits.

NMR Pulse Sequences: Fundamental to the process of producing quantitative pO₂ maps is the ability to acquire accurate calculated T1 images in vivo through implementation of practical imaging protocols. A desirable protocol would provide calculated T1 data within a single imaging sequence in order to minimize artifacts associated with subject motion or other experimental instabilities which might occur during a repeated sequence. In addition, utilization of an efficient single imaging sequence would assist in reducing data acquisition time and thus help to offset the increased time associated with F-19 signal averaging necessitated by the relatively low signal-to-noise characteristics of PFCs in vivo [8]. An example of the saturation recovery/inversion recovery (SR/IR) pulse protocol [13] implemented for the 2D projection images shown in this paper is provided in Figure 3. In brief, two data sets (spin echoes S₁ and S₂) are acquired in the single sequence. The ratio $R = S_1/S_2$ is a function of T1 as well as the various timing parameters t_a , τ , and t_b .

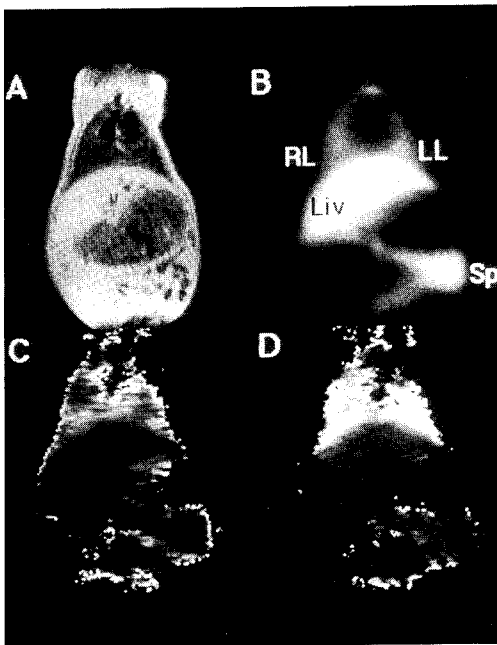

FIGURE 1: A qualitative illustration of the potential for oxygen sensitive F-19 MR imaging in the porcine model two days post IP administration of the FC-43 based emulsion Oxypherol-ET. Field strength 0.14T (5.96 MHz proton; 5.61 MHz fluorine). (a) Coronal proton image serving as an anatomic localizer (5 mm slice thickness). (b) Spin echo F-19 projection image. Organs labeled: liver (LIV), spleen (SP), right/ left lungs (RL/LL). (c) and (d) Calculated pO_2 projection images (derived from calculated T1 images and the calibrated relationship to pO_2) under conditions of normal (ambient air) and enhanced oxygen (~250 torr) inspiration respectively [from References 8 and 14].

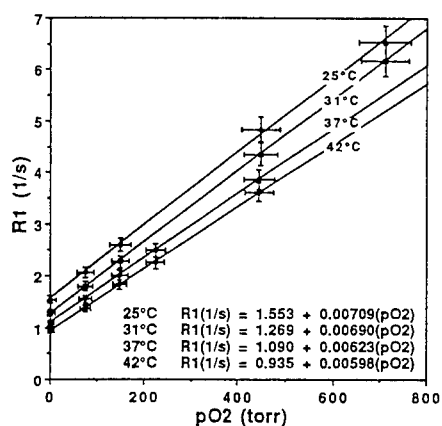

FIGURE 2: FC-43 calibration curves as a function of temperature at 0.14T.

Saturation-Recovery/ Inversion Recovery Pulse Sequence for Obtaining Calculated T1 Images

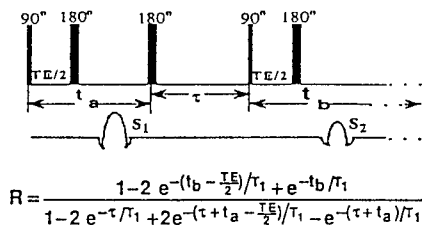

FIGURE 3: Saturation recovery/inversion recovery NMR pulse sequence sensitive to T1 [13]. S1 and S2 represent the two echo signals acquired in the sequence. R = S1/S2

A look-up table based on the analytical expression for R is used to determine T1 from the measured S1 and S2 echo intensities. We have sought to optimize these parameters for maximum accuracy in the calculated T1 image [14]. The optimal values are found to be dependent on pO₂ as well as on in vivo S/N ratio. Thus, sequences tailored to a specific pO₂ range are required.

Our current focus is on performance evaluation of fast gradient recalled echo (GRE) 3D-volume acquisition imaging protocols for pO₂ quantitation. These sequences provide the potential advantage of improved S/N ratios through utilization of shorter echo times (TE) and elimination of slice misregistration artifacts due to the large PFC F-19 chemical shift characteristics. In addition, they offer the flexibility of variable slice plane orientation and thickness through post processing [15].

Aqueous Environment Considerations: The potential for quantitative oxygen sensitive F-19 NMR imaging of PFC compounds in vivo requires that fluorocarbon T1 changes correlate with the local oxygen tension (pO₂) and not with composition of the surrounding immiscible aqueous phase [16]. We have conducted a series of experiments to evaluate the influence of varied bioconstituents and paramagnetic ions within the aqueous phase on the F-19 fluorocarbon phase T1 over the range 0.14 to 0.66T for two commercial PFC containing emulsions and a polyfluorinated surfactant. The emulsions included: a.) Oxypherol-ET containing 20 w/v% perfluorotributylamine (FC-43) [17], and b.) Oxygent-HT containing 90 w/v% perfluorooctylbromide (PFOB or perflubron) [18,19]. The surfactant, known as XMO-10 (10 w/v%), has the chemical formula C₃F₇O(CF₂)₃CONH(CH₂)₃NO(CH₃)₂ [16,20]. The commercial emulsions are opaque (milky white) with a mean particle size in the range 0.1 to 0.2 μm. The transparent nature of XMO-10 suggests a significantly smaller particle size (perhaps 0.001 to 0.01 μm) [21]. However, the possibility does exist that this transparency might result from serendipitous matching of indices of refraction and, therefore, XMO-10 might not be a true microemulsion. Controlled variables introduced within the emulsion aqueous phase included annex solution constituents of the emulsion base, blood admixture, pH regulation (pH 6 to 11), and gadolinium DTPA paramagnetic complex (0.01 to 1.0 mmol/L emulsion, Magnevist®, Berlex Laboratories, Wayne, New Jersey, USA). The fluorocarbon T1 was independent (as desirable) of the emulsion base constituents, blood concentration, and pH over the test range. The F-19 T1 for Oxypherol-ET shown in Figure 4 is independent of the Gd-DTPA

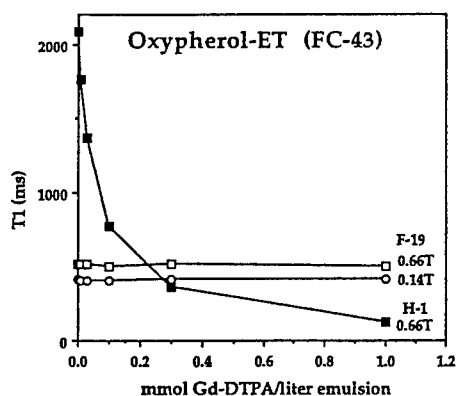

FIGURE 4: T1 values for the Oxypherol-ET emulsion as a function of Gd-DTPA concentration in the aqueous phase. Fluorocarbon phase (F-19) T1 values were measured at two magnetic field strengths (0.14T and 0.66T) while proton (H-1) T1 values were determined at 0.66T.

concentration within experimental uncertainty while the aqueous phase proton (H-1) T1 dropped by more than one order of magnitude. Similar results were observed for Oxygent-HT. For XMO-10, with the smallest particle size (possibly 10 to 100 times smaller than those for the commercial emulsions), results at 0.66T suggested a slight decrease in the F-19 T1 (~12%) toward the highest Gd-DTPA concentrations. This effect is consistent with aqueous phase surface interaction being non-negligible relative to the bulk volume characteristics when the fluorocarbon particle size is reduced to dimensions approaching the order of the paramagnetic range.

PFC Routes to the Pulmonary Airway: This paper is intended primarily as an illustration of quantitative pO_2 imaging of organs in vivo including lung in a porcine model following IP administration of the commercial PFC emulsion, Oxypherol-ET. However, the lung is unique in that two routes for PFC distribution to the alveoli are available: 1.) transport through the vascular compartment after IV or IP administration and 2.) direct introduction via external airway (liquid ventilation,

intratracheal instillation, or aerosol inhalation). Immediately following isovolumic exchange of blood for Oxypherol-ET to attain a 5% fluorocrit (estimated 10 g% FC-43 per 100 mL blood), the opportunity is present for oxygen sensitive visualization of the vascular system. Figure 5 illustrates this capability in the pig heart. Gated projection F-19 images of the heart chambers (blood pool) under conditions of lung ventilation with 21 and 95% oxygen ($F_iO_2 = 0.21$ and 0.95) are shown in correlation with the slice selected proton image gated at the same point in the cardiac cycle. Oxygen enhancement is demonstrated both in comparison of the signal strengths between the two F-19 images at different F_iO_2 (Figures 5b and 5c) and also within an image (Figure 5b) where the oxygen depleted mixed venous blood in the right heart is less intense than the oxygen rich arterial blood in the left heart.

Porcine Model Preparation: Young domestic swine were administered an IP injection of 50 mL Oxypherol-ET emulsion (~ 10g FC-43) per kilogram body weight 3 to 6 days prior to the MR imaging. Indwelling catheters were placed in the aorta (systemic arterial), pulmonary artery (mixed venous), and hepatic vein (hepatic venous) allowing vascular sampling simultaneous with the MR imaging as a direct method of monitoring circulatory system pO_2 which define organ supply or drainage sites. The anesthetized animals were supported with mechanical ventilation during MR imaging with fraction inspired oxygen (F_iO_2) controlled from 0.21 (ambient air) to 0.95 with 15 to 30 minutes allowed for equilibrium between each step. Airway (trachea) pO_2 was monitored also through direct gas sampling. Blood and air samples were analyzed for oxygen partial pressure on a BMS Mark 3 Radiometer Clinical Gas Analyzer. All porcine imaging was performed at 0.14T on our low-field, custom-designed MR research system [22].

RESULTS

An example of the data image sets obtained are shown in Figure 1 including the proton (H-1) image providing anatomic correlation, the F-19 spin echo image demonstrating PFC biodistribution, and the calculated pO_2 images enabling quantitative pO_2 readout via region-of-interest interrogation. Figure 6 illustrates contour projection map presentation providing direct visual indication of regional pO_2 distribution. A total of five (5) pigs were studied under the IP administration protocol. Table 1 provides the data for one animal (different from that of Figure 6). In general, for lung parenchyma, the pO_2 maps demonstrated a heterogenous distribution of oxygen with maximum pO_2 values tracking inspired oxygen. For liver, only a modest

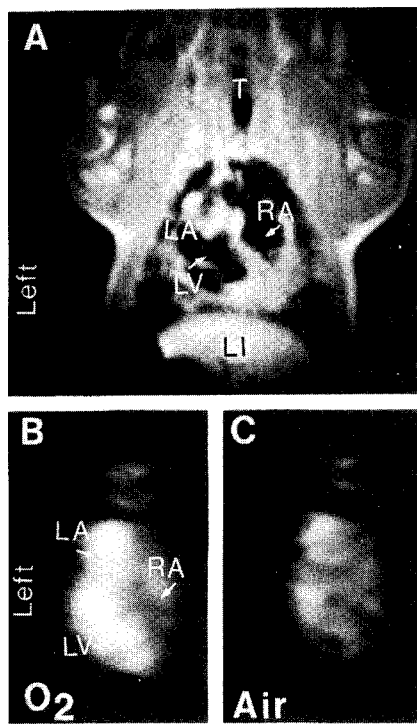

FIGURE 5: Porcine model, blood contains ~ 10g FC-43 per 100 mL; 0.14T; gated 80 ms after onset of ventricular systole. (a) Dorsal view, coronal proton image (10 mm) of an anesthetized pig at the level of the cardiac atria. (b) and (c) Dorsal view F-19 projection images at the same point in the cardiac cycle during 95% oxygen (b) and 21% oxygen (c) breathing. Organs labeled: trachea (T), left/right atrium (LA/RA), left ventricle (LV), liver (LI).

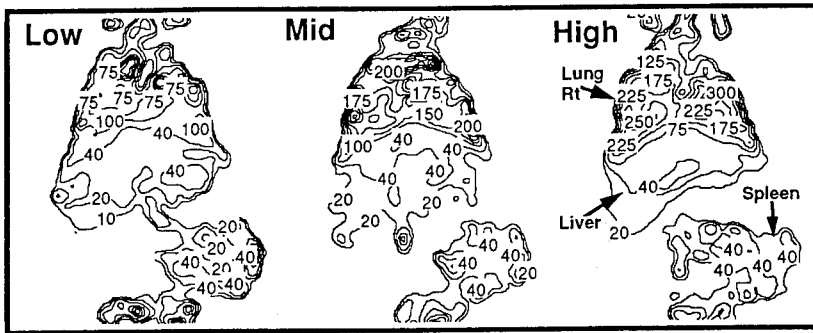

FIGURE 6: pO_2 contour maps for the porcine model at 0.14T under conditions of three varied inspired oxygen levels: Low = room air; Mid = 1.5 L/min O_2 supplemental; High = 3.5 L/min O_2 supplemental.

TABLE I: pO_2 Quantitation (Pig #3930)

Relative Inspired Oxygen	Direct pO_2 measurement (torr)				Calculated pO_2 (torr: mean \pm error)			
	Arterial (Aorta)	Venous (Hepatic Vein)	Pulmonary Artery	Airway	Right Lung	Left Lung	Liver	Spleen
Low (ambient)	83	36	41	129	44 \pm 11	33 \pm 10	7 \pm 9	23 \pm 10
Mid (0.5 L/min)	130	39	47	135	112 \pm 14	96 \pm 13	11 \pm 9	43 \pm 11
Mid (2.0 L/min)	215	37	48	320	246 \pm 21	239 \pm 20	30 \pm 10	75 \pm 12
High (5.0 L/min)	319	38	51	426	354 \pm 26	262 \pm 21	26 \pm 10	167 \pm 17

rise in pO_2 values was observed when F_iO_2 was increased significantly. This response is consistent with hepatic venous blood pO_2 variation. However, as the liver receives both systemic arterial (hepatic artery) and venous (portal vein) blood, it is uncertain at present as to the most appropriate correlative vascular pool source for the calculated tissue pO_2 values. The spleen, a dynamically contractile organ with arterial supply, might be expected to reflect arterial blood most closely. In three ani-

Porcine Apical Lobe Pathology

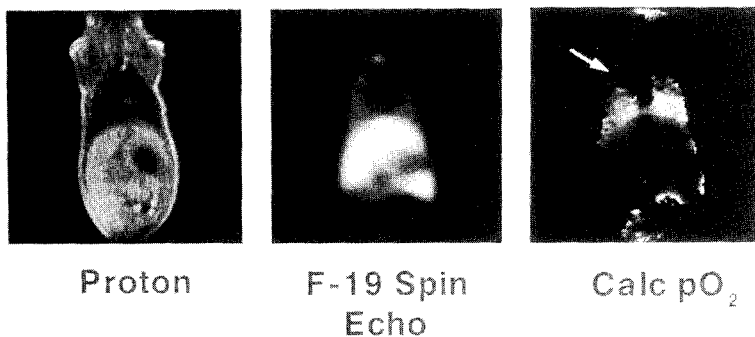

FIGURE 7: Porcine apical lobe pathology: a demonstration of the potential for identification of regions of compromised pO₂. Low pO₂ values are manifest as a signal deficit in the upper right lung (arrow). At autopsy, the right apical lobe presented with a pneumonia-type pathology.

mals, the spleen did exhibit dramatic elevation in pO₂ at the highest F_iO₂ (example Table 1) while for the others, little enhancement was observed (example Figure 6).

A demonstration of the potential for identification of pathologic status and tissue viability is provided in Figure 7. The spin echo image presents normal PFC distribution through all organs including the right lung. However, the calculated pO₂ projection image indicates abnormally low pO₂ values manifest as a signal deficit in the upper right lung. On autopsy, the right apical lobe was found to be non-inflated and to have the appearance of a pneumonia type pathology (filled with water) with a dark red color (rather than the normal pink).

A final adaptation of the model entailed euthanasia of one pig within the MR magnet. Maintaining post mortem cyclical inflation of the in situ lung under varied oxygen levels, the calculated pO₂ distribution in the lung was similar to that obtained in the living pig prior to euthanasia (i.e., reflective of inspired airway pO₂) while the values in liver and spleen dropped to ~ 0 pO₂ as expected during circulatory arrest. Thus, this study supports the hypothesis that in vivo pO₂ lung images obtained by F-19 NMR under normal circulation are informative of the alveolar pO₂ conditions and not of the pulmonary arterial, capillary, or venous blood pO₂ status.

DISCUSSION

A porcine model has been used to demonstrate non-invasive quantitation of organ oxygenation in vivo with F-19 NMR imaging of PFC resident in selected tissues. The MR techniques employed must be optimized for maximum efficiency to minimize uncertainty in the calculated pO₂ images. An accuracy of ± 5 torr within the pO₂ range of physiological interest is predicted to be achievable at low magnetic fields. Tissue pO₂ maps may be utilized to track tissue oxygen distribution and to monitor physiologic function/status in correlation with inspired oxygen levels. Tissue specific oxygen delivery efficiency may be evaluated and local regions of compromised pO₂ identified. As a specific organ, the lung presents an exciting horizon of opportunity for unique physiologic monitoring in association with the dual routes of PFC delivery; namely, internal (vascular) and external (airway).

ACKNOWLEDGEMENTS

Supported in part by the NIH Grants R01 #HL45243 and P01 #HL22619 (Core I).

REFERENCES

1. S.R. Thomas. "The Biomedical Applications of Fluorine-19 NMR" in Magnetic Resonance Imaging, Second Edition: Volume II: Physical Principles and Instrumentation. Edited by C.L. Partain, R.R. Price, J.A. Patton, et al. W.B. Saunders, Philadelphia, Pennsylvania, pp. 1536-1552 (1988).
2. L.C. Clark, Jr., J.L. Ackerman, S.R. Thomas, and R.W. Millard. "High Contrast Tissue and Blood Oxygen Imaging Based on Fluorocarbon 19-F NMR Relaxation Times." The Society of Magnetic Resonance in Medicine, Second Annual Meeting, San Francisco, California (1983). (Abstract book, p. 95-96.)
3. R.P. Mason. "Non-Invasive Physiology: 19F NMR of Perfluorocarbons." Biomaterials, Artificial Cells, and Immobilization Biotechnology, this volume (1993).
4. S.R. Thomas, L.C. Clark, Jr., J.L. Ackerman, et al. "MR Imaging of the Lung Using Liquid Perfluorocarbons." J. of Computer Assisted Tomography, 10(1):1-9 (1986).
5. J.E. Fishman, P.M. Joseph, T.F. Floyd, et al. "Oxygen-Sensitive F-19 NMR Imaging of the Vascular System In Vivo." Magnetic Resonance Imaging, 5:279-285 (1987).
6. R.P. Mason, F.M. Jeffrey, C.R. Malloy, et al. "A Non-Invasive Assessment of Myocardial Oxygen Tension: 19F NMR Spectroscopy of Sequestered Perfluorocarbon Emulsion." Magnetic Resonance in Medicine, 27:310-317 (1992).

7. C.A. Wilson, B.A. Berkowitz, B.W. McCuen, II, et al. "Measurement of Preretinal Oxygen Tension in Vitrectomized Human Eye Using Fluorine-19 Magnetic Resonance Spectroscopy." *Arch. Ophthalmol.*, 110:1098-1100 (1992).
8. S.R. Thomas, R.W. Millard, R.G. Pratt, et al. "Partial Pressure of Oxygen (pO₂) Imaging Using F-19 NMR of Perfluorocarbon Blood Substitute Emulsions in the Porcine Model." Society of Magnetic Resonance in Medicine, Ninth Annual Meeting, New York, NY (1990). (Abstract book, p. 573.)
9. L.J. Busse, S.R. Thomas, R.G. Pratt, et al. "Deconvolution Techniques for Removing the Effects of Chemical Shift in ¹⁹F Nuclear Magnetic Resonance Imaging of Perfluorocarbon Compounds." *Medical Physics*, 13(4): 518-524 (1986).
10. L.J. Busse, R.G. Pratt, and S.R. Thomas. "Deconvolution of Chemical Shift Spectra in Two- or Three-Dimensional [¹⁹F] MR Imaging." *J. of Computer Assisted Tomography*, 12(5): 824-835 (1988).
11. P. Parhami and B.M. Fung. "Fluorine-19 Relaxation Study of Perfluorochemicals as Oxygen Carriers." *J. Phys. Chem.*, 87:1928-1931 (1983).
12. C.S. Lai, S.J. Stair, H. Miziorko, et al. "Effect of Oxygen and the Lipid Spin Label TEMPO-Laurate on Fluorine-19 and Proton Relaxation Rates of the Perfluorochemical Blood Substitute, FC-43 Emulsion." *J. of Magnetic Resonance*, 57:447-452 (1984).
13. I.L. Pykett, B.R. Rosen, F.S. Buonanna, et al. "Measurement of Spin-Lattice Relaxation Times in Nuclear Magnetic Resonance Imaging." *Phys. Med. Biol.*, 28:723-729 (1983).
14. S.R. Thomas, R.G. Pratt, Y. Shiferaw, and R.W. Millard. "Evaluation of a T1 Imaging Sequence for the In Vivo Imaging of pO₂ Using Perfluorocarbon (PFC) F-19 NMR." Society of Magnetic Resonance in Medicine, Eleventh Annual Meeting, Berlin, Germany (1992). (Abstract book, p. 4311.)
15. R.G. Pratt, Y. Shiferaw, and S.R. Thomas. "Utilization of a Gradient Echo F-19 3D-Volume Acquisition Imaging Protocol for Quantitation of pO₂ in Perfluorinated Blood Substitutes." Radiological Society of North America 78th Scientific Assembly and Annual Meeting, Chicago, IL (1992).
16. S.R. Thomas, R.G. Pratt, R.W. Millard, et al. "Evaluation of the Influence of the Aqueous-Phase Bioconstituent Environment on the F-19 T1 of Perfluorocarbon Blood Substitute Emulsions." Radiological Society of North America 77th Scientific Assembly and Annual Meeting, Chicago, IL, (1991). (Abstract book, p. 159.) Manuscript submitted for publication (1993).
17. Alpha Therapeutic Corporation, 5555 Valley Blvd., Los Angeles, CA 92121 (Distributor) and Green Cross Corporation, Osaka, 932-1201 1/3, Camon-Cho, Joto-ku, Japan (Manufacturer).

18. Alliance Pharmaceutical Corp., 3040 Science Park Road, San Diego, CA 92121.
19. J.G. Riess, J.L. Dalfors, G.K. Hanna, et al. "Development of Highly Fluid, Concentrated and Stable Fluorocarbon Emulsions for Diagnosis and Therapy." *Biomat., Art. Cells and Immob. Biotech.*, 20:839-842, 1992.
20. L.C. Clark, Jr., E.W. Clark, R.E. Moore, et al. "Room Temperature-Stable Biocompatible Fluorocarbon Emulsions" in Advances in Blood Substitute Research. Edited by R. Bolin, R.P. Geyer, and G.J. Nemo. Alan R. Liss, New York, Progress in Clinical and Biological Research, 122:169-180 (1983).
21. R.F. Burton. "Ringer Solutions and Physiological Salines." Chapter XII: Oxygenation and the Use of Dispersed Fluorocarbons. John Wright & Sons, Ltd., Dorchester, pp. 70-72, 1975.
22. S.R. Thomas, J.L. Ackerman, and J.G. Kereiakes. "Practical Aspects Involved in the Design and Set Up of a 0.15T, 6-Coil Resistive Magnet, Whole Body NMR Imaging Facility." *Magnetic Resonance Imaging*, 2:341-348 (1984).

**PHARMACOKINETICS AND SIDE EFFECTS OF
PERFLUOROCARBON-BASED BLOOD SUBSTITUTES**

Stephen F. Flaim, Ph.D.
Alliance Pharmaceutical Corp., San Diego, CA 92121

ABSTRACT

Perfluorochemicals are fluorine-saturated carbon-based molecules which demonstrate utility in the areas of imaging and oxygen delivery. In general, these molecules are biologically inert and, therefore, do not pose toxicologic risk from metabolic degradation. Intravenous (i.v.) perfluorocarbon (PFC) emulsions are cleared from the blood through a process involving phagocytosis of emulsion particles by reticuloendothelial macrophages (RES) and ultimate elimination through the lung in expired air. RES phagocytosis of PFC emulsion particles leads to characteristic, predictable, and reversible biological effects that are a consequence of a normal host-defense mechanism. This mechanism is characterized by dose-related stimulation of macrophages and subsequent release of intracellular products (particularly metabolites of the arachidonic acid cascade and cytokines) which are responsible for most of the biological effects associated with i.v. PFC emulsions (i.e., cutaneous flushing and fever at lower doses, and macrophage hypertrophy and recruitment at higher doses). These biological effects are reversible, and do not result in any permanent tissue alteration, even with prolonged exposure at relatively high doses. The rate of PFC elimination from the RES is proportional to the vapor pressure of the PFC, inversely proportional to molecular weight and positively influenced by lipophilicity. This dose-dependent respiratory excretion occurs with no evidence of metabolic products. Repeated administration of high doses of PFC emulsion may lead to a saturation of the RES-mediated clearance capacity, resulting in a redistribution of PFC to non-RES tissues and ingestion by resident or mobile macrophages. This condition is benign with respect to the integrity of the surrounding parenchyma, as well as to the macrophages themselves. Increased pulmonary residual volume (IPRV) due to pulmonary gas (air) trapping, a reversible side effect, has been

observed with i.v. doses of PFC emulsion in some animal species. The gross morphological change associated with IPRV is not accompanied by any histological alteration other than the appearance of vacuolated macrophages (characteristic of the normal clearance mechanism) and some minor, increased interalveolar cellularity. Animal lungs affected by IPRV have a normal, pale pink appearance with no visible lesions or signs of edema. The degree of IPRV is dependent on species, PFC dose, and type of PFC administered; PFCs with higher vapor pressures produce the most severe cases of IPRV in sensitive species. Species sensitivity depends upon physiological and morphological characteristics. There is no evidence indicating that IPRV occurs in humans. Although i.v. PFC emulsions may elicit minor untoward effects, these effects are reversible and, at clinically relevant doses, do not pose a toxicologic risk.

INTRODUCTION

Perfluorocarbons (PFCs), as a class, have an inherent chemical and biological stability associated with the strength of the carbon-fluorine bond [1] and the physical arrangement of the atoms in the molecule. The electronegative fluorine atoms form a dense electron coating around the molecule that shields the molecule from chemical attack [2]. As a result, PFCs are not degraded by other chemicals except under extreme, non biological conditions[2]. PFCs with biologically appropriate vapor pressures and molecular weights are no more toxic than polytetrafluoroethylene (i.e. *Teflon*®), a chemically similar molecule with well-documented chemical and biological inertness [3].

Due to their insolubility in water, PFCs must be emulsified before they can be administered parenterally. The first PFC emulsions intended for medical use were developed in the late 1960s, and the first commercially available PFC emulsion, *Fluosol*®, was produced in 1974 by *Green Cross Corp.* of Japan. *Fluosol* is a 20% w/v PFC emulsion (14 g/dL perfluorodecalin and 6 g/dL perfluorotripropylamine) which contains egg yolk phospholipid (EYP) and poloxamer-188 as the emulsifying agents and requires frozen storage and must be used within 7-8 hours of reconstitution. *Fluosol* was first investigated in the United States as an oxygen-carrying blood substitute, and clinical trials for this indication have been conducted. During these trials, patients received doses of up to 5.0 g PFC/kg. *Fluosol* has received approval for use during percutaneous transluminal coronary angioplasty (PTCA) in the United States and in the United Kingdom. To date, *Fluosol* and related emulsion products have been administered safely to over 1500 patients and subjects worldwide.

In 1986, emulsions with significantly higher PFC concentration (up to 100% w/v PFC) than previously achieved were developed by *Alliance Pharmaceutical Corp.* The PFC used in these high-concentration emulsions is perflubron (perfluorooctyl bromide), a linear brominated fluorocarbon with the chemical composition $\text{CF}_3(\text{CF}_2)_6\text{CF}_2\text{Br}$. Perflubron emulsions contain a pharmaceutical grade EYP and are stable for several months at room temperature. Perflubron emulsions are currently under development as diagnostic contrast agents for use with major imaging modalities (perflubron emulsions receive their radiopacity from the terminal Br atom of the perflubron molecule), as a temporary oxygen carrier during surgical procedures, and for adjunctive treatment for use in various cardiovascular and cancer applications. Considerable progress has been made in the understanding of the clinical side-effect profile of i.v. administered perflubron emulsion.

RETICULOENDOTHELIAL SYSTEM

Following the i.v. injection of perflubron emulsion, the emulsion particles (EYP-coated perflubron) undergo opsonization (binding of plasma proteins to circulating emulsion particles), a process which promotes recognition of the emulsion particles by cells of the reticuloendothelial system (RES) and facilitates phagocytosis. Opsonization is a normal, characteristic response to the introduction of particulates (including fat emulsions, liposomes, and PFC emulsions) into the blood. The opsonized emulsion particles are cleared from the blood by RES phagocytosis, with the liver, spleen, and bone marrow accounting for essentially all of the removal. Opsonization and clearance of emulsion particles by RES cells occurs relatively quickly and results in the rapid removal of these particles from the circulation [circulating half-life ($t_{1/2}$) of approximately 4 to 10 hours].

INCREASED PULMONARY RESIDUAL VOLUME

While RES phagocytosis is the primary means by which a perflubron emulsion is removed from the circulation, a minor component of initial blood clearance involves direct vaporization and exhalation of perflubron. As the circulating emulsion particles pass through the pulmonary capillaries, PFC is transported across the blood-air interface and is eliminated into alveolar air as a vapor. This direct vaporization of perflubron from the circulation may contribute directly to a phenomenon observed in some animal species referred to as PFC-induced increased pulmonary residual volume (IPRV). IPRV is characterized by lungs which fail to deflate normally when the thorax is opened at necropsy

and has been reported in association with the i.v. administration of various PFC emulsions [4-10]. Pulmonary gas (air) trapping is the mechanism hypothesized to be responsible for IPRV. There is some evidence to suggest an interaction between lung surfactant and PFC that may contribute to air trapping in the lung; foam or air bubble production is observed *in vitro* when PFC is added to lung surfactant. Similarly, foam is released from IPRV lungs (i.e., lungs that have trapped air and do not deflate) when cut at necropsy. The gross morphological change associated with IPRV (increased lung volume due to trapped air) is not accompanied by any histological alteration other than the appearance of vacuolated macrophages (characteristic of the clearance mechanism) and some minor, increased interalveolar cellularity. Lungs affected by IPRV have a normal, pale pink appearance with no visible lesions or signs of interstitial pulmonary edema.

Dose-dependent IPRV has been observed to occur within a few days following intravenous (i.v.) administration of PFC emulsion in some animal species (rats, rabbits, domestic swine, and cynomolgus monkeys). Reversal of IPRV is also dose-dependent. IPRV associated with i.v. perflubron emulsion administration is resolved completely within 3 to 4 weeks following clinically relevant doses. At higher doses of perflubron emulsion (i.e., 5.4 g PFC/kg in swine, 8.1 g PFC/kg in rabbits, and 8.1 and 10.8 g PFC/kg in monkeys) observations of respiratory distress (dyspnea, rapid and/or labored breathing) have been associated with postmortem findings of increased lung volume. Lethalities were also observed at these doses in sensitive species. However, a direct relationship linking the lethality to IPRV has not been established. In comparison, i.v. *Fluosol* resulted in moribund sacrifices, and/or death in rabbits (2.7 g PFC/kg) and monkeys (9 g PFC/kg) with no signs of IPRV reversal at 3 weeks (rabbits) or 6 weeks (monkeys) postdosing. Again, a direct relationship of lethality in these *Fluosol*-treated animals to IPRV has not been established. The degree of IPRV is therefore dependent on species (rabbits, pigs, and monkeys are most susceptible while dogs, rats and mice are the least sensitive species tested to date), dose, and type of PFC administered; PFCs with lower boiling points (i.e., higher vapor pressures) produce the most severe cases of IPRV.

Possible effects of IPRV on pulmonary function are not well characterized at this time. Dose-related decreases in arterial PO_2 (PaO_2) have been measured in perflubron emulsion-treated monkeys in association with postmortem observations IPRV. *Fluosol* is also associated with decreased PaO_2 in monkeys and *Fluosol*-treated rabbits experience a transient decrease in PaO_2 beginning shortly after infusion that can be minimized by prior corticosteroid administration [10]. No changes in pulmonary function or arterial blood gases have been observed in perflubron emulsion-treated dogs (up to 10.8 g PFC/kg).

Light microscopy evaluations of perflubron emulsion- and *Fluosol*-treated rabbit and monkey lungs have, in general, indicated slightly increased mononuclear cell number, slight distention of alveoli, and some increased interalveolar cellularity. Electron micrographs show noncellular membranes, possibly surfactant, spanning alveolar pores and an increased number of alveolar Type II cells have been observed. Vacuolated macrophages also appear in the intima of blood vessels of these lungs. No evidence of interstitial edema, necrosis, or fibrosis has been observed in any of the lung tissues analyzed.

There is no evidence indicating that IPRV occurs in humans; at least 1500 patients and subjects have received *Fluosol* or similar emulsions and more than 100 patients and subjects have received i.v. perflubron emulsions with no reports of serious adverse pulmonary effects which can be attributed to IPRV. Case reports of edematous pulmonary infiltration following *Fluosol* administration in a small number of patients have been published [10-12]. Ventilation-perfusion scans in these patients were normal and, as edema has not been observed in animals with IPRV, any relationship of the clinical findings in these few patients to IPRV is questionable.

Species sensitivity to IPRV appears to correlate with several physiologic and morphologic characteristics (Table I). IPRV is less likely to occur in species having large alveolar and terminal airway dimensions, high transpulmonary pressures ($> 3 \text{ cmH}_2\text{O}$), a high degree of pulmonary collateral ventilation, as well as a pharmacokinetic profile which results in an attenuated exposure of the lung to circulating PFC (i.e. species with effective initial RES clearance mechanisms). Insensitive species include mouse, rat, and dog. Human possesses all the determinants which, in other species such as dog, correlates with insensitivity to PFC-induced IPRV (Table I). Therefore, it appears that human can be grouped with those species which are insensitive to IPRV.

PHARMACOKINETICS

RES phagocytosis is the primary means by which i.v. PFC emulsions are removed from the circulation. Following RES phagocytosis, intracellular perflubron (in RES cells) crosses the cell membrane to lipid carriers in the circulation with ultimate elimination from the body as a vapor through the lung in the expired air (i.e., similar to volatile anesthetics). This latter exposure of the lungs is a slower process compared to the exposure incurred during direct vaporization of PFCs from circulating emulsion particles. The rate of PFC elimination from the RES is a function of the vapor pressure and lipophilicity of the PFC and is inversely proportional to the molecular weight [13-14] (e.g., RES elimination half-life of perflubron is 3 days compared to 7 and 65 days for perfluorodecalin and

TABLE I. Comparison of species with respect to physiological and morphological determinants of IPRV sensitivity.

	High Transpulmonary Pressures	Large Airway Dimensions	Slow PFC Lung Delivery	Pulmonary Collateral Ventilation	
				Alveolar	Lobular
Sensitive Species					
Rabbit	NO	NO	NO	NO	YES
Swine	ND	YES	NO	YES	NO
Monkey	NO	YES	ND	YES	YES
Insensitive Species					
Mouse	YES	NO	ND	YES	YES
Rat	YES	NO	YES	YES	YES
Dog	YES	YES	YES	YES	YES
Human	YES	YES	YES	YES	YES

ND = no data available

perfluorotripropylamine respectively[3]). This dose-dependent respiratory excretion of PFCs occurs with no evidence of metabolic products. No urinary excretion and insignificant fecal excretion of perflubron are observed with i.v. perflubron emulsion. Perflubron is only very slightly soluble in lipid and, as a result, a small portion of RES-released perflubron translocates to adipose tissue. Distribution of perflubron from fat back into the blood occurs at a rate determined by the fat/blood solubility ratio. Throughout the RES-mediated clearance process, no organ damage is manifested, as documented by histological examination of tissues at various intervals up to six months following i.v. perflubron emulsion in rats and dogs.

Following iv administration of perflubron emulsion (2.7 g PFC/kg) in rats, blood perflubron levels declined within the first 24 hours postdosing with an estimated half-life of approximately 4 to 8 hours. Thereafter, blood perflubron concentrations continued to decline gradually over the remainder of the 28-day study from the highest concentrations measured immediately postdosing (approximately 80000 µg PFC/mL blood) to less than 14 µg PFC/mL by 3 days, and to levels below quantifiable limits (less than 0.2 µg PFC/mL) by 28 days. At 24 hours postdosing, the quantity of perflubron in the liver and spleen represented approximately 80% of the total perflubron contained in all the tissues analyzed (liver, spleen, adipose, lung, kidney, skeletal muscle, brain, lymph node, intestine, stomach, and heart) with the highest splenic (64600 µg/g) and hepatic (22200

$\mu\text{g/g}$) concentrations occurring at 24 hours and 3 days postdosing, respectively. The perflubron content of these tissues declined with a half-life of approximately 3 days; clearance was virtually complete by 56 days postdosing. Perflubron concentrations in adipose tissue increased gradually to a maximum at 7 days postdosing ($5900 \mu\text{g/g}$) and then decreased thereafter with a half-life of approximately 14 days. Accumulation of perflubron in adipose during the first week postdosing represents a redistribution of perflubron from the liver and spleen. Although adipose contained the majority of detectable perflubron in tissues from 14 to 56 days postdosing, the perflubron remaining in adipose tissue at 56 days represented less than 2% of the total administered dose. Overall, gradual clearance of perflubron from all tissues was evident over the time course of this study (1 hour to 56 days).

SIDE-EFFECTS

Phagocytosis by the RES macrophages in the liver and spleen leads to characteristic, predictable, and reversible biological effects that are a consequence of a normal host-defense mechanism. This mechanism is characterized by dose-related stimulation of macrophages and subsequent release of intracellular products, which have various biological effects ranging from induction of transient, flu-like symptoms (fever and chills, with occasional headache and/or nausea with or without vomiting) at lower doses, to microscopically evident macrophage hypertrophy and recruitment at higher doses. It is well recognized that phagocytosis stimulates the macrophage to secrete a variety of active substances, which can affect both neighboring and distant tissues. These substances can include hydrolytic enzymes, coagulation factors, complement components, lipids, and reactive oxygen intermediates. The degree of secretory response, i.e., substance type, amount, and duration, is largely dependent upon the properties of the ingested particle. Chemically reactive particles, such as lipopolysaccharides or xenobiotics, can result in significant cytotoxicity ranging from fibrosis to necrosis. In contrast, unreactive particles, including perflubron emulsion particles, result in a temporary stimulation and a mild, reversible response which can be attributed largely to the release of prostaglandins and endoperoxide products of the arachidonic acid cascade.

Intravenous infusion of PFC emulsion during clinical trials has been associated with a side-effect profile that includes both an immediate response (cutaneous flushing and occasional lower back pain) during or shortly after infusion and a delayed response (2 to 12 hours) consisting of a flu-like syndrome (primarily fever with occasional chills and nausea), all of which resolve spontaneously, usually within 12 hours of onset. The mechanism of action of these side-effects has been studied in animals (particularly

conscious swine) and is consistent with the mechanism of macrophage stimulation (during phagocytosis of emulsion particles) and release of biologically-active substances [15]. These animal studies indicate that the phagocytosis of perflubron emulsion particles results in the release of metabolites of the arachidonic acid cascade (e.g., thromboxane and prostaglandins), and cytokines (e.g., interleukin-1 β) which together are responsible for the side-effects observed. In addition, it has been determined that these side-effects are not associated with the release of histamine, serotonin, bradykinin, or leukotriene D₄, and are not the result of immune reactions, activation of the plasma contact system, platelet activation, complement activation, or emulsion-induced changes in systemic blood flow (i.e., the reported, occasional lower back pain is not associated with a reduction in renal blood flow).

Systemic release of the arachidonic acid metabolites thromboxane and prostaglandins accounts for the immediate side-effect (i.e., skin-flushing) of PFC emulsion infusion in the animal models. Upon stimulation, and as a part of the normal phagocytic response to foreign particles, macrophages generate prostaglandins and thromboxane secondary to the stimulation of the arachidonic acid cascade. Prostaglandin D₂ causes local vasodilatation of the cutaneous circulation and is responsible for the skin flushing often associated with the administration of niacin. The immediate skin flushing response in the animal model can be blocked by pretreatment with an experimental, long plasma half-life thromboxane A₂ receptor antagonist (SQ 29,548; Bristol Myers-Squibb Corp., Princeton, NJ). The delayed response (i.e., fever) may also result from products of the arachidonic acid cascade. Alternatively (or in addition), activation of blood leukocytes by phagocytosis of the emulsion particles may lead to the production of low levels of cytokines (i.e., interleukin-1, interleukin-6, and tumor necrosis factor), which enter the central nervous system and enhance the local release of prostaglandin E₂. Prostaglandin E₂, in turn, acts on the thermoregulatory center of the hypothalamus to induce fever. Both the immediate and delayed effects are eliminated by the use of readily available corticosteroids and long plasma half-life cyclooxygenase inhibitors.

TOXICITY

Acute (single dose) toxicity studies in mice, rats, and dogs have indicated that the acute lethality margin of perflubron emulsion is species-dependent and varies between 25 and 54 g PFC/kg for the species studied. The absolute no effect doses are in the range of 2.7 to 9 g PFC/kg with the effects observed at higher non-lethal doses limited primarily to enlargement of the spleen and liver. Other studies in rats have indicated that the enlargement of the liver commonly observed following perflubron emulsion

administration is not associated with peroxisome proliferation and can be best explained by a proliferation of macrophages (Kupffer cells) in this organ associated with the uptake of perflubron. The changes observed in these acute studies reflect clearance of the injected emulsion via the RES (a normal host defense mechanism) and are not regarded as significant adverse effects.

In a rat subchronic toxicity study (dosed twice weekly to a cumulative dose of 1.8 to 27 g PFC/kg), lethality related directly to perflubron emulsion did not occur. Hematology changes (seen only at the highest cumulative doses of 13.5 and 27 g PFC/kg), included a moderate reduction in red blood cell counts and a small increase in reticulocyte and leukocyte counts. Clinical chemistry changes, confined primarily to the highest dose groups, included moderate increases in serum liver enzymes, urea nitrogen and creatinine, and a slight reduction in the albumin/globulin ratio. These chemical and hematological changes are most likely associated with RES cell uptake of the emulsion particles. Other treatment-related effects included increases in liver, spleen, kidney, and lung organ weight. Treatment-related microscopic alterations consisted of dose-dependent accumulation of vacuolated macrophages in the spleen, liver, lung, and kidneys, as would be expected with a proliferation of macrophages and uptake of the PFC. All effects were either completely or significantly reversed after an eight-week recovery period. Following 26 weeks of recovery, the only treatment-related observation was a slightly enlarged spleen with a few vacuolated macrophages in some of the higher dose animals.

In another rat subchronic (repeat dosing) study, the two highest doses (total cumulative doses ranged from 2.4 to 48.6 g PFC/kg) resulted in the formation of vacuolated macrophages in the liver, spleen, lungs and kidneys (RES organs) as well as the adrenal cortex, intestines, lymph nodes, bone marrow, eye, ovary, and epididymis. The appearance of vacuolated macrophages in numerous non-RES organs indicates a saturation of RES capacity and overflow of perflubron into other tissues. In each case, the only vacuolated cells observed histologically were macrophages and in no instance did the tissue macrophages appear to be damaged or adversely affected by the ingested particles. In addition, with the exception of the liver, the surrounding parenchyma of these organs showed no damage associated with the presence of the perflubron-laden macrophages. In the liver, vacuolated macrophages were so extensive at these higher doses that impingement by these cells on adjacent hepatocytes resulted in occasional hepatocyte necrosis. Also at the two higher doses, changes in clinical chemistry and hematology parameters, consistent with RES uptake of perflubron, were observed, including a moderate reduction in red blood cell and platelet counts, an increase in reticulocyte and

leukocyte counts, and increases in serum liver enzymes. The mechanism for the erythrocytopenia, which has been observed only in rats, most likely involves an increased rate of removal of senescent red cells by splenic macrophages as *in vitro* red blood cell hemolysis studies have confirmed that perflubron emulsion, even under very severe conditions, does not lyse red blood cells directly. Other treatment-related effects at these higher doses included increased liver, spleen, lung, kidney, and adrenal organ weights due to macrophage proliferation and accumulation of PFC.

Even with the relatively high tissue exposures achieved in these two subchronic animal studies, no irreversible treatment-related effects of perflubron emulsion administration have been observed. Acute lethality occurred in mice, rats and dogs following single i.v. doses, equivalent to the administration of 1.5 L or more of a 90% w/v concentrated perflubron emulsion to a normovolemic person weighing 60 kg. At lower single doses, the only biologically important effect observed in these species was the accumulation of vacuolated macrophages in, and resulting enlargement of, the spleen and liver. This accumulation of vacuolated macrophages is a reflection of the normal RES-mediated clearance mechanism of the emulsion particles and is completely reversible. Whereas i.v. perflubron emulsion is associated with some physiological responses, none result in any permanent tissue alteration (even with prolonged exposure at relatively high doses) and none appear to pose a toxicological risk. Finally, preclinical studies have found no teratogenicity, genotoxicity, cytotoxicity, dermal sensitization, or hemolytic activity associated with perflubron emulsion.

SUMMARY

Intravenous PFC emulsion is eliminated from the body through a process involving RES phagocytosis of emulsion particles, liposolubilization of intracellular PFC (to re-enter the circulation), and ultimate elimination as a vapor through the lung in expired air. The macrophage is the common cellular element responsible for essentially all of the side effects associated with perflubron (and other PFCs) emulsion infusion. Data generated in animals provide strong evidence to conclude that the emulsion particles are phagocytosed primarily by reticuloendothelial macrophages in the liver and spleen. The effects are reversible, and do not result in any permanent tissue alteration, even with prolonged exposure at relatively high dose levels. After phagocytosis by the macrophage, PFCs do not cause further stimulation and do not undergo any biological degradation. The appearance of vacuolated macrophages in non-RES tissues of rats indicates that repetitive administration of high doses of perflubron emulsion may lead to saturation of the RES-mediated clearance capacity. This saturation results in a redistribution of the material to

non-RES tissues and ingestion by resident or mobile macrophages. This condition is benign with respect to the integrity of the surrounding parenchyma, as well as to the macrophages themselves. RES phagocytosis of PFC emulsion particles leads to characteristic, predictable, and reversible biological effects that are a consequence of a normal host-defense mechanism. Much progress has been made in understanding the mechanism of these side effects which are now known to occur secondary to macrophage activation and stimulation of the arachidonic acid cascade. These side effects can largely be blocked by prophylaxis with corticosteroids. Increased pulmonary residual volume (IPRV), a reversible side effect, has been observed with high doses of PFC emulsion in some animal species. The gross morphological change associated with IPRV (i.e., increased lung volume due to trapped air) is not accompanied by any histological alteration other than the appearance of some vacuolated macrophages (characteristic of the particulate clearance mechanism) and some minor, increased interalveolar cellularity. There is no evidence indicating that IPRV occurs in humans; over 1500 patients and subjects have received i.v. *Fluosol* and related emulsion products and more than 100 patients have received i.v. perflubron emulsion with no reports of serious changes in lung function which can be attributed to IPRV. Whereas perflubron and other PFC emulsions may elicit minor untoward effects, these effects do not appear to pose a toxicologic risk; all known effects of i.v. PFC emulsions are reversible and are not associated with any short- or long-term deleterious consequences.

ACKNOWLEDGMENTS

The author would like to acknowledge the contributions of the entire staff of the Biological Sciences Division at *Alliance Pharmaceutical Corp.* In particular, the efforts of D.C. Saewert and T.K. Fields in support of this effort are greatly appreciated.

REFERENCES

1. J.G. Riess. Overview of progress in the fluorocarbon approach to *in vivo* oxygen delivery. Blood Substitutes and Oxygen Carriers. T.M.S. Chang (ed), Marcel Dekker Inc., New York, p. 24 (1993).
2. J.C. Tatlow. Aspects of organofluorine chemicals. Organofluorine chemicals and their industrial applications. R.E. Banks (ed), Ellis Horwood Ltd., Chichester, p. 19 (1979).
3. J.G. Riess. Blood substitutes: Where do we stand with the fluorocarbon approach? *Curr Surg* 45:365-370 (1988).

4. M. Kitazawa and Y. Ohnishi. Long term experiment of perfluorochemicals using rabbits. *Virchow Arch (Pathol Anal)* 398:1-10 (1982).
5. L. Nanney, L.M. Fink and R. Virmani. Perfluorochemicals: morphologic changes in infused liver, spleen, lung, and kidney of rabbits. *Arch Pathol Lab Med* 108:631-637 (1984).
6. Y. Ohnishi and M. Kitazawa . Application of perfluorochemicals in human beings. A morphological report of a human autopsy case with some experimental studies using rabbit. *Acta Pathol Jpn* 30:489-504 (1980).
7. Y. Tsuda, K. Nakura, K. Yamanouchi, K. Yokoyama, M/ Watanabe, H. Ohyanagi and Y. Saitoh. Study of the excretion mechanism of a perfluorochemical emulsion. *Artificial Organs* 13:197-203 (1989).
8. L.C. Clark, R.E. Hoffmann, R.B. Spokane and P.E. Winston. Physiological evaluation of fluorocarbon emulsions with notes on F-decalin and pulmonary inflation in the rabbit. *Mat Res Soc Symp Proc* 110:129-134 (1989).
9. L.C. Clark, R.E. Hoffmann and S.L. Davis. Response of the rabbit lung as a criterion of safety for fluorocarbon breathing and blood substitutes. *Biomat Art Cell Immob Biotech* 20:1085-1099 (1992).
10. G.M. Vercellotti , D.E. Hammerschmidt , P.R. Craddock and H.S. Jacob. Activation of plasma complement by perfluorocarbon artificial blood: probable mechanism of adverse pulmonary reactions in treated patients and rationale for corticosteroid prophylaxis. *Blood* 59:1299-1304 (1982).
11. A.M. Police , K. Waxman and G. Toninaga . Pulmonary complications after Fluosol administration to patients with life threatening blood loss. *Crit Care Med* 13:96-98 (1985).
12. K. Waxman , K.K. Tremper, B.F. Cullen and G.R. Mason . Perfluorocarbon infusion in bleeding patients refusing blood transfusions. *Arch Surg* 119:721-724 (1984).
13. J.G. Riess and M. Le Blanc. Solubility and transport phenomena in PFCs relevant to blood substitution and other biomedical applications. *Pure and Appl Chem* 54:2383-2406 (1982).
14. J.G. Riess. Reassessment of criteria for the selection of perfluorochemicals for second generation blood substitutes: Analysis of structure/property relationships. *Artif Org* 8:44-56 (1984).
15. S.F. Flaim, D.R. Hazard , J. Hogan and R.M. Peters . Characterization and mechanism of side-effects of *Imagent*[®] BP (highly concentrated fluorocarbon emulsion) in swine. *Invest Radiol* 26:S122-S124 (1991).

FUNCTIONAL MR IMAGING OF A METABOLITE OF $^{17}\text{O}_2$

Sigmund E. Lasker
Department of Medicine
New York Medical College
Valhalla, New York 10595

The observation of Meiboom [1] in 1961 of the shortening of the transverse relaxation time of the proton of H_2O was correctly interpreted as the presence of a small concentration of naturally occurring H_2^{17}O in water. Hopkins and his group [2] at Case Western Reserve were the first to apply this observation to a continuing series of physiological experiments using proton spectroscopic and imaging studies of injected H_2^{17}O . Arai, et. al. [3], further extended the use of the stable isotope of oxygen as a gas solubilized in a fluorocarbon emulsion to detect the product of in situ metabolized $^{17}\text{O}_2$, in the normal dog brain using proton magnetic resonance imaging. Mateescu [4], Pekar [5] as well as Arai et. al. [6], detected "nascent" water in normal animals breathing $^{17}\text{O}_2$ enriched air. Pekar, using a double tuned experimental imaging system was able to image both $^{17}\text{O}_2$ and the proton of H_2^{17}O . We have applied the use of either fluorocarbon emulsions saturated with $^{17}\text{O}_2$ or $^{17}\text{O}_2$ gas to study pathological states where we can expect to observe local metabolic alterations as in ischemic reperfusion injury in the heart or in middle cerebral artery occlusion [7] in the rat brain. Our observations suggest that $^{17}\text{O}_2$ uptake

and its conversion to a metabolite with a proton in proximity to $^{17}\text{O}_2$ (H_2^{17}O) is imaged immediately after reperfusion at the site of the experimentally-induced ischemia in the dog heart. However, a well established rat brain infarct with poor perfusion does not present the enhanced metabolism necessary to visualize the conversion of $^{17}\text{O}_2$ to H_2^{17}O .

INTRODUCTION

Early studies by Meiboom [1] demonstrated that a small concentration of naturally occurring H_2^{17}O in H_2^{16}O caused a significant shortening of the proton transverse relaxation (T_2) when compared to the longitudinal relaxation (T_1). Hopkins [2] applied this observation to physiological phenomena in a continuing series of studies.

Studies of experimental ischemia using short lived radioactive isotopic oxygen are the basis for much of the data on oxygen extraction and consumption and regional blood flow particularly in the brain [8]. The stable isotope of oxygen can be detected by NMR spectroscopy but cannot be imaged by available clinical imagers. The proton of the metabolic product of $^{17}\text{O}_2$, molecular H_2^{17}O , whether produced in vivo or injected can serve as either a tag for distributed water or as a marker of metabolic processes in situ. Stable oxygen isotope has been commercially available as an enriched gas or as H_2^{17}O as well as incorporated into organic molecules [9]. Arai et. al [6] and Pekar et al [5] using inhaled $^{17}\text{O}_2$ were concerned with the in vivo measurement of cerebral oxygen utilization and blood flow. The techniques presented cannot distinguish between H_2^{17}O generated in the brain and reflow of metabolic water from other organs. A small effect not usually considered in these experiments is the fractionation effect by hemoglobin on isotopes of oxygen with mass differences [10].

Our approach using $^{17}\text{O}_2$ delivered intravenously with a fluorocarbon carrier or as a gas, has been directed toward observing metabolic events

following ischemic reperfusion injury in the dog heart or in the rat brain after development of an ischemic injury. The experimental studies are based on clinical observations in nonhemorrhagic cerebral hemispheric infarction which showed elevated oxygen extraction in the region of the early infarct.

Magnetic resonance imaging of the heart opens a new vista for exploring on a more basic molecular level, and most significantly - noninvasively - some of the phenomena that are associated with tissue injury, traumatic as well as disease generated. The basis for clinical magnetic resonance imaging of protons is the magnetic field generated in the microenvironment of protons in tissue. The protons of lipid, bone and fluids behave uniquely in a magnetic field and therefore provide contrast, permitting organs, vessels, cavities and fluid collections to be distinguishable from one another. However, the molecular basis for contrast observed are primarily differences in the relaxation of protons and is complex and can be influenced by susceptibility effects, chemical shifts as well as instrumental parameters. The presence of $^{17}\text{O}_2$ in the water molecule reduces the proton relaxation time T_2 which is manifest as a negative contrast in the observed proton image. The T_1 proton image is not significantly influenced by the presence of enriched $^{17}\text{O}_2$. The in-situ conversion of the injected highly enriched natural occurring stable isotope, $^{17}\text{O}_2$, to an NMR observable metabolite is the basis of observation of local metabolic alterations in the reperfused myocardium of the dog or in the transiently occluded middle cerebral artery of the rat.

MATERIALS AND METHODS

By means of a left thoracotomy at the fifth intercostal space of the mongrel dog, the descending coronary artery was isolated and a circumferential hydraulic occluder was placed just distal to the first diagonal branch. The occluder when filled, permits complete occlusion

of the coronary artery. Care was taken to prevent obstruction of the coronary artery when in the deflated position. The pericardium which is excised is left open following the surgery. The occluder filling catheter is tunneled subcutaneously to an exit wound in the flank. The chest is closed in layers and the lungs reinflated with negative pressure to the sealed chest cavity. The surgery is performed under pentobarbital anesthesia, pulmonary ventilation and aseptic conditions as well as under AALAC approved conditions according to a protocol approved by the Animal Research committee of New York Medical College.

Ligation of the left anterior descending coronary artery distal to the first septal branch is maintained for 30 minutes with inflated balloon occluder. Figure 1 details the sequence of experimental events in the canine occlusion model. Simultaneously with the release of the occluder, a bolus of fifty ml of enriched $^{17}\text{O}_2$ [57 atoms %] dissolved in 50 ml of a fluorocarbon emulsion as carrier is delivered rapidly through the cannulated inferior vena cava. The pO_2 of the $^{17}\text{O}_2$ carrier mixture is at least 600 mmHg at atmospheric pressure. The occlusion and infusion is accomplished while the pentobarbital anesthetized dog is positioned in a standard knee coil or head coil of the MRI Scanner with the heart in the isocenter of the field. Cardiac imaging is performed before occlusion, during occlusion and after release of the occluder and injection of $^{17}\text{O}_2$ -perfluorocarbon emulsion. An identical experiment using $^{16}\text{O}_2$ was also performed. Image accumulations for 13 minute periods were observed during the experiment.

A General Electric Signa 1.5 imaging system at a proton frequency of 63.9 MHz is used to observe the proton density image of the electrocardio-graphically gated dog heart.

The scalar coupling interactions between the quadrupolar $^{17}\text{O}_2$ and protons in H_2^{17}O at neutral pH as well as in other proton derivatives of $^{17}\text{O}_2$ significantly shortens the proton transverse relaxation time [T_2] suggesting its use as a negative imaging contrast agent. By delivering

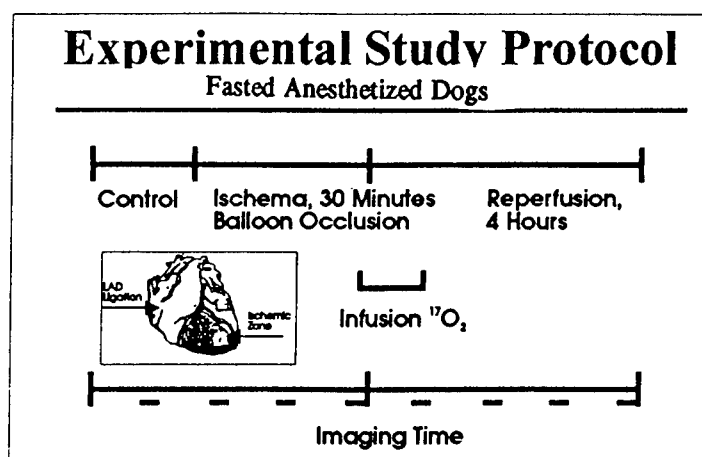

FIGURE 1. Sequence of experimental events following placement of balloon occluder at left anterior descending artery of the dog.

enriched $^{17}\text{O}_2$ to metabolically altered tissue sites, the presence of $^{17}\text{O}_2$ metabolites generated in-situ at regions of altered oxygen consumption may be detected by contrast changes. In our experimental model, the NMR detection of in-situ conversion of $^{17}\text{O}_2$ is dependent on instrumental variables and on a multiplicity of biochemical variables including the level of $^{17}\text{O}_2$ enrichment and delivery, the magnitude, rate and extent of conversion as well as the diffusion of metabolites.

The experiments using the dog as our model system present a number of technical problems. Because of the rapid and variable heart rate of the dog, we are limited in our imaging protocols and our images are not fully T_2 weighted. We have been able to produce images of good contrast with a repetition time of 2000 ms and an echo time of 40 ms for a total scan time of 13 minutes. The imaging protocols are dependent on the heart rate which can vary following reperfusion. We have attempted to minimize pharmacologic intervention during these

experiments. Although we are maintaining a lidocaine level during the reperfusion to prevent fibrillation, resuscitation following a significant drop in pressure or fibrillation requires termination of the experiment and exclusion of the data.

Hemisphere cerebral ischemia was induced in the Ketamine anesthetized rat by threading a 4.0 nylon suture into the right internal cerebral artery to occlude the middle cerebral artery. The thread was removed thirty minutes after middle cerebral artery occlusion following total occlusion of the right carotid artery. A typical infarct appeared seven hours after occlusion and was observed in the T_2 proton magnetic resonance image as an enhanced contrast in the right hemisphere. Images were produced in the MRI scanner either with a constructed 5 cm solenoid coil or with the standard General Electric wrist coil. Eighteen hours after the ischemic injury, 40 ml of $^{17}\text{O}_2$ gas was delivered intraperitoneally. Proton NMR images were observed hourly for three hours starting 2 hours after the intraperitoneal injection.

RESULTS

Since the scalar coupling interactions between quadropolar ^{17}O and protons in H_2^{17}O significantly shortens the proton relaxation time T_2 , the in-situ cascade of single electron reductions of deoxygen to water at a reactive site would become apparent as negative contrast.

The upper left image A of Figure 2 shows a 5 mm transverse section of the heart in the region of the apex supplied by the LAD before occlusion with the occluder in place. The second image (B) after 15 minutes of occlusion shows no further significant change. Following 30 minutes of occlusion, release of the occluder and introduction of $^{17}\text{O}_2$, shown in image C, a significant loss of signal is apparent at a locus in the anterior wall region of the apex. After an additional 30 minutes there is enhanced signal in the anterior region but a reduction in negative intensity in a small region that previously showed significant

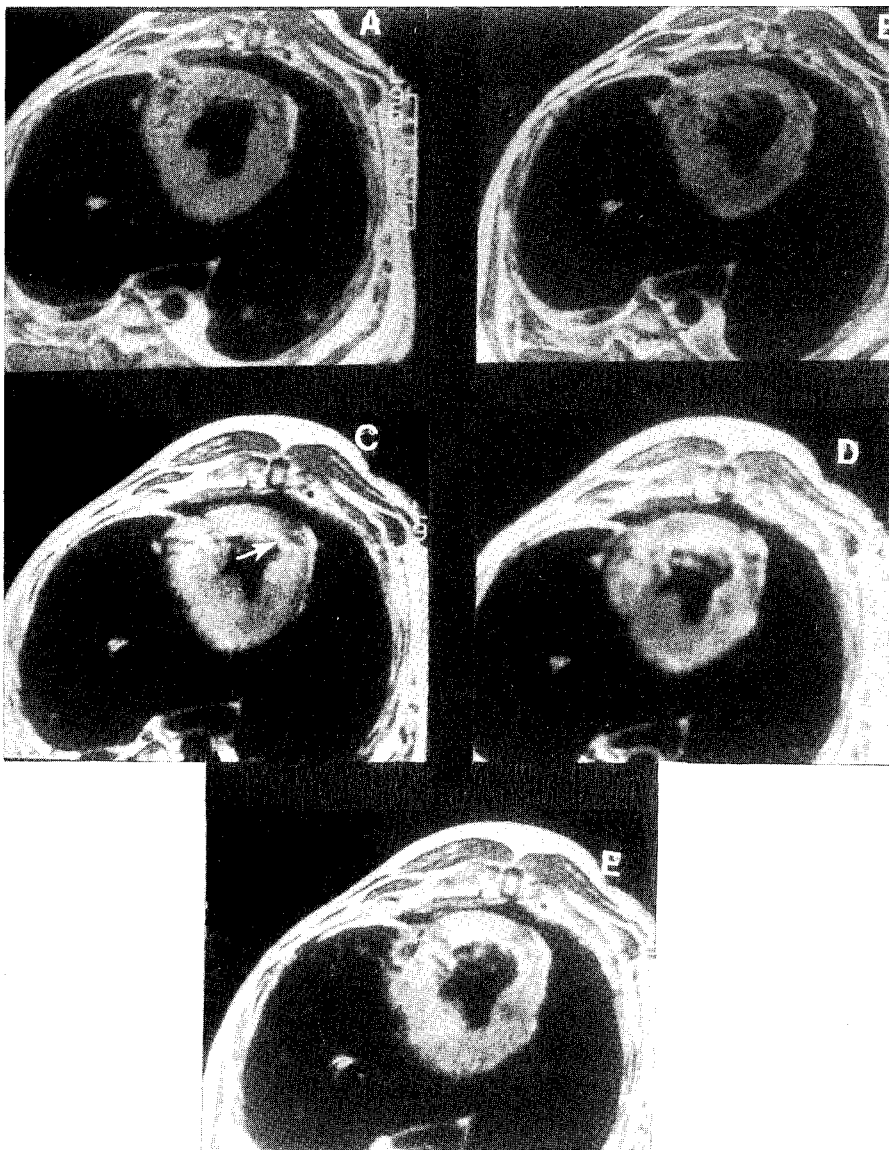

FIGURE 2. Cross sectional image through the midsection of the left ventricle 5 mm slices, T_2 weighted images showing development of high intensity signal in anterior wall as well as localized loss of signal arrow. Image A: before occlusion; B: during occlusion; C: immediately after release of occluder and infusion of perfluorocarbon- $^{17}\text{O}_2$; D: 30 minutes following release of occluder.

negative contrast. Figure 3 is a series of slices 6.5 mm cephalad taken at the same time as the first series. The first 5 mm slice, image F, taken before occlusion; the second image E taken during the period of occlusion; the third slice, image H, after infusion of $^{17}\text{O}_2$ and release of the occluder shows the region of negative contrast which is dissipated after 15 minutes. After 30 additional minutes, image I reveals enhanced contrast in the anterior wall region.

Figure 4 shows the same time sequence of images 13 mm cephalad. Image M shows a significant loss of signal in the anterior region and image N shows a significant signal enhancement thirty minutes later.

Images collected before occlusion and during occlusion of the LAD showed uniform intensity in 9 dogs. Following $^{17}\text{O}_2$ infusion in eight experiments, three showed an area of negative contrast in the anterior region of the left ventricular wall, two images were not interpretable because of noise, two died following reperfusion and one showed uniform contrast in the left ventricular wall. Parallel experiments in the dog with $^{16}\text{O}_2$ which does not metabolize to MRI observable water were unrevealing and served as a control validating the observation of negative contrast in the reperfused region of the anterior ventricular wall. Following the infusion of $^{16}\text{O}_2$ and after release of the occluder, images of the left ventricular wall in four dogs revealed uniform intensity.

In the rat brain experiments, the slow absorption of $^{17}\text{O}_2$ from the peritoneal cavity of the rat and its conversion to H_2^{17}O in the brain as well as H_2^{17}O transported to the brain from other metabolically active organs did not alter the high intensity of the T_2 weighted image of the infarcted region of the rat brain. The left hemisphere and regions adjacent to the infarct, however, developed observable negative T_2 contrast.

DISCUSSION

The transient appearance of a region of high negative contrast on T_2 images in the anterior region of the left ventricle followed by the

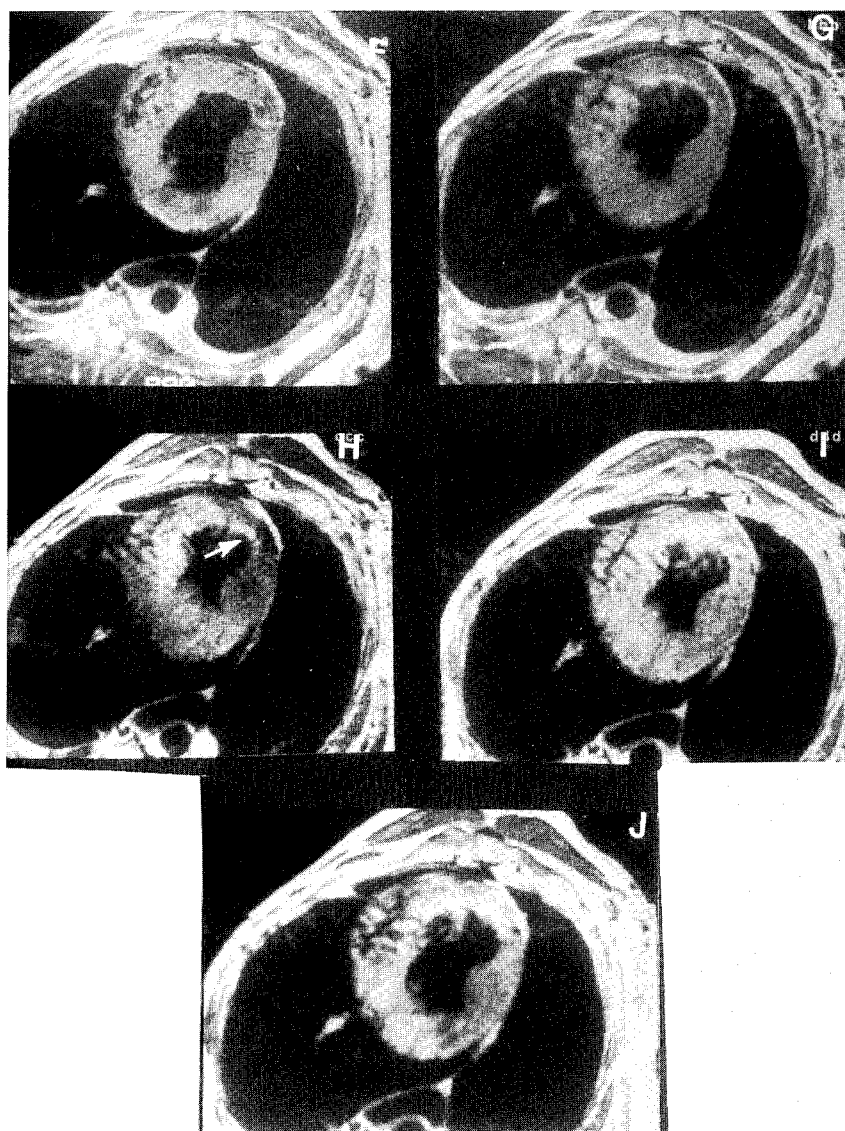

FIGURE 3. Cross sectional images as in FIGURE 2 but displaced cephalad. 6.5 mm region of ventricular wall with transient negative contrast at arrow.

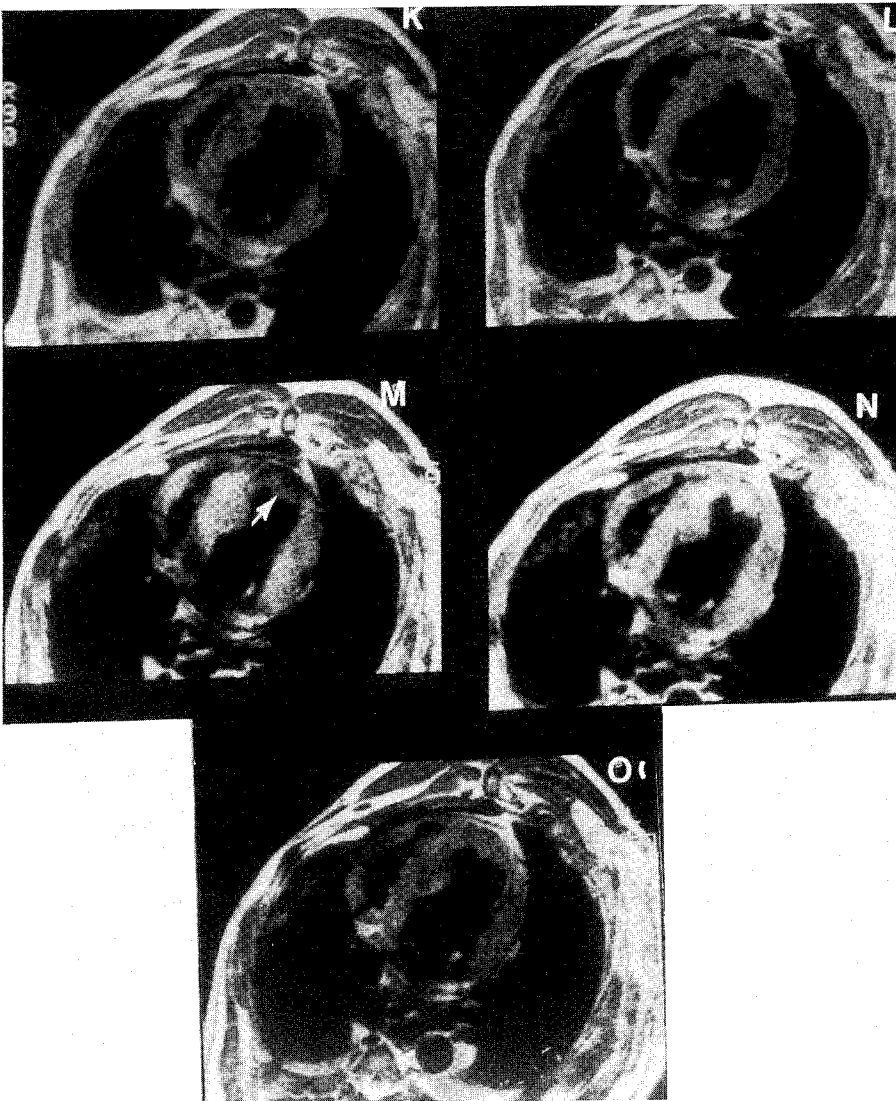

FIGURE 4. Cross sectional images as in FIGURE 2 but displaced cephalad 13.5 mm region of the left ventricular wall showing negative contrast.

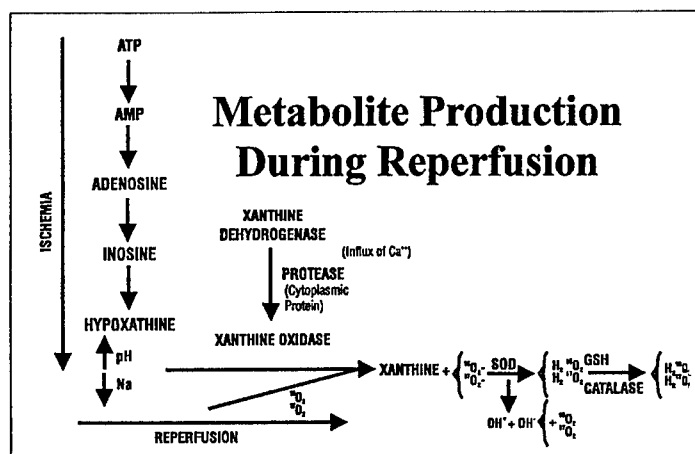

FIGURE 5. Schematic representation of metabolic events during ischemia and following reperfusion in the presence of $^{17}\text{O}_2$.

expected high intensity of the infarct is not readily rationalized quantitatively on the basis of $^{17}\text{O}_2$ delivered systemically and metabolized to H_2^{17}O . Hopkins [11] was not able to detect changes in image intensity in the brain following incremental Intraperitoneal injections of H_2^{17}O until a total concentration of 0.4 - 0.5% was obtained. However, when H_2^{17}O is generated in-situ, at a metabolically altered site, our data suggests a metabolic heterogeneity in response to the reversible ischemic injury. Generally, prolongation of T_2 is correlated with elevation of water content within ischemic tissue. The total water content of soft tissues is similar; however, the collagenous matrix of myocardial cells precludes massive cellular swelling. The contrast observed in MRI in different tissues of the freely diffusible water may be related to the microenvironment consisting of macro molecular and subcellular components [12]. The multiplicity of mechanisms of altered relaxation times in injured tissues are not yet

developed. In addition to the state of water in injured tissue, the role of regional oxygenation in ischemic tissue on the transverse relaxation time T_2 of protons has been suggested [13].

The temporal parameters including the relatively long imaging time necessary for our study in relation to the transient events being investigated have not yet been fully explored but the development of negative contrast observed immediately following reperfusion associated with the in-situ reduction of $^{17}\text{O}_2$ is not observed when an injury has proceeded to an infarct as in the established infarct in the rat brain. Studies performed in collaboration with Drs. E. Garcia and S. Sharma showed that when 15 minutes of occlusion of the middle cerebral artery of the rat brain is followed by 18 hours of reperfusion permitting the establishment of an observable infarct, negative contrast following $^{17}\text{O}_2$ infusion is limited to the region surrounding the infarct.

It has been suggested that cells in the ischemic myocardium respond temporally and unequally to occlusion and reperfusion. The subendocardial myocardium responds early followed by the subepicardial myocardium [14]. Perfusion tissue damage associated with the reintroduction of coronary flow following a period of ischemia may be accompanied by a complex of sudden changes including increase in ultrastructural changes, enzyme release, calcium influx, pH changes and electrolyte derangements [15]. The cascade of the univalent reductions of the oxygen molecule to form the reactive free-radical - the mitochondrial superoxide anion as well as the subsequent intracellular reduction product, hydrogen peroxide and its enzymatic degradative product water may be enhanced in the reperfused myocardium. Whether the reperfusion production of peroxide and free radicals is a function of myocardial cells or activated leukocytes is not established. However, the sudden increase in oxygen consumption a few seconds after the interaction of the cell with a stimulus, has been studied [16].

The invasion of circulating neutrophils in myocardial tissue or endothelial cells may be the origin of reactive oxygen metabolites.

Studies of the reversible ischemic injury of myocardial ventricular wall are potentially an approach to evaluating the viable myocardial wall and an early marker for viability following acute reperfusion.

ACKNOWLEDGEMENTS

This overview of the $^{17}\text{O}_2$ literature included studies whose participants were A. Baez, P. Gupta, J. Priest, Jr., Drs. S. Sharma, S. Garcia and S. Schulssman. Dr. Anthony Pucillo provided insightful discussion of the cardiac images.

REFERENCES

1. S. Meiboom. Nuclear magnetic resonance study of the proton transfer in water. *J. Chem. Phys.* 3x, 375 (1961)
2. A. L. Hopkins, et. al. The stability of proton T_2 effects of oxygen-17 water in experimental cerebral ischemia. *Magn. Reson. Med.* 22:167-174 (1991)
3. T. Arai, P. M. Gupte, S. E. Lasker, L. R. M. Delguercio and K. Mori. Method for the detection of tissue metabolite (H_2^{17}O) in brain by proton magnetic resonance imaging. *Crit. Care Med.* 17:1333-1334 (1989)
4. G. D. Mateesau, et. al. Oxygen-17 magnetic resonance in-vivo detection of nascent mitochondrial water in animals breathing $^{17}\text{O}_2$ enriched air. *SMRM, Aug. 1991, works in Progress* 1031
5. J. Pekar, L. Ligett, Z. Ruttner, R. C. Lyon, T. M. Sinnwar, P. Van Geldern, D. Fiat, C. T. W. Moonen, and A. C. McLaughlin. In-vivo measurement of cerebral oxygen consumption and blood flow using ^{17}O magnetic resonance imaging. *Magn. Reson. in Med.* 21:313-319 (1991)
6. T. Arai, S. Nakao, K. Mori, K. Ishimori, I. Morishima, T. Miyazawa, and B. Zieroth, Cerebral oxygen utilization analyzed by the use of oxygen-17 and its nuclear magnetic resonance. *Biochem. Biophys. Res. Comm.* 169:153-158 (1990)

7. H. Benveniste, L. W. Hedlund, and G. H. Johnson. Acute cerebral ischemia in rats: mechanism of detection by diffusion-weighted magnetic resonance microscopy. *Stroke* 72:259-268 (1991)
8. G. L. Lenzi, T. Jones, C. G. McKenzie, and S. Moss. Non-invasive regional study of chronic cerebrovascular disorder using oxygen-15 inhalation technique. *J. Neurology, Neurosurgery and Psychiatry* 41:11-17 (1978)
9. A.L. Hopkins and R. G. Bass. Oxygen-17 compounds as potential NMR T₂ contrast agents: enrichment effects of H₂¹⁷O on protein solutions and living tissues. *Magn. Reson. Med.* 4:399-403 (1987)
10. K. D. Schuster and K. P. Pflug. The overall fractionation effect of isotopic oxygen molecules during oxygen transport and utilization in humans in "Oxygen Transport to Tissues" XI. K. Rakusan et al eds. Plenum, New York (1988)
11. A. L. Hopkins, E. M. Haacke, J. Tkach, R. G. Barr, and C. B. Bratton. Improved sensitivity of proton MR to oxygen-17 as contrast agent usin fast imaging: detection brain. *Magn. Reson. Med* 7:222-229 (1988)
12. S. H. Koenig. Dynamics of water-protein interactions in water in polymers. Ed. S. P. Rowland (ACS Symposium No. 127 Washington, D. C. D1570176, 1980)
13. K. R. Thulborn, J. C. Waterton, D. M. Matthews, and G. K. Radda. Oxygenation dependence of the transverse relaxation time of water protons in whole blood at high field. *Biochem. Biophys. Acta* 714:265-270 (1982)
14. K. A. Reimer, J. E. Lowe, M. M. rasmussen, R. B. Jennings. The wavefront phenomenon of ischemi cell death 1-myocardial infarct size vs duration of coronary occlusion in dogs. *Circulation* 56:786-793 (1976)
15. P. D. V. Bardellon , P. A. Poole-Wilson. Effects of ischemia and reperfusion on calcium exchange and mechanical function in myocardium. *Card. Res.* 15:121-130 (1981)
16. C. R. DeChatelet. Interaction of the respiratory burst in human polymorphonuclear neutrophils. *J. Ret. Soc.* 24:73-91 (1978)

**CARDIOVASCULAR APPLICATIONS OF FLUOROCARBONS
IN REGIONAL ISCHEMIA/REPERFUSION**

Robert A. Kloner, M.D., Ph.D. and Sharon Hale, BS

**Heart Institute, Hospital of the Good Samaritan and University of Southern
California**

616 S. Witmer

Los Angeles, California 90017

ABSTRACT

Potential cardiovascular therapeutic uses for perfluorochemicals include oxygen delivery distal to an occluding balloon during high risk coronary angioplasties, treatment for acute myocardial infarction with or without concomitant reperfusion, cardioplegia, and preservation of donor hearts for transplant. Infusions of oxygenated perfluorochemicals during brief coronary occlusions, as occurs with angioplasties, preserves cardiac ultrastructure and cardiac function. Fluosol is currently approved in the U.S. for angioplasty procedures. Experimental studies have suggested that perfluorochemicals reduce myocardial infarct size during permanent coronary occlusion or temporary coronary occlusion. One school of thought suggests that these agents work by reducing reperfusion injury. By inhibiting neutrophil function, including adherence to endothelial cells and release of toxic substances, perfluorochemicals may preserve the endothelium and prevent no-reflow. However, one might argue that any agent which reduces infarct size by any mechanism would result in less neutrophil infiltration and smaller no-reflow areas. One pilot study suggested that intracoronary Fluosol administered at the time of reperfusion, reduced infarct size and improved regional ventricular function in patients. However, preliminary results of a large multicenter study in which this agent was given along with thrombolysis, were largely negative. Whether perfluorochemicals will become

an important adjunctive agent along with reperfusion for acute myocardial infarction remains to be determined.

CARDIOVASCULAR APPLICATIONS OF FLUOROCARBONS

Fluorocarbons have therapeutic potential in a wide array of cardiovascular disorders. To date they have been studied as therapies for high risk angioplasty, myocardial infarction, cardioplegia, and preservation of hearts during heart transplant, and possible echocardiographic contrast agents. This paper will concentrate on the use of fluorocarbons to protect ischemic myocardium during regional ischemia - that is during angioplasty and myocardial infarction. The rationale for using these substances in ischemic syndromes is that 1) they have high oxygen carrying capability 2) their small particle size might allow access of these particles to regions where erythrocytes might not reach and 3) their low viscosity might lead to improved tissue perfusion.

FLUOROCARBONS AND ANGIOPLASTY

Angioplasty has become a major therapeutic intervention for coronary artery disease. Angioplasty balloons are capable of dilating stenotic coronary arteries successfully in a high percentage of cases [1]. Unfortunately, while the angioplasty balloon is inflated, blood flow is cut off to the distal myocardium. This results in ischemia of the myocardium supplied by the occluded vessel with subsequent angina pectoris, ST segment shifts, lactate production, and regional ventricular wall motion abnormalities. In high-risk angioplasty cases, this period of ischemia may result in morbidity and may lessen the duration that the angioplasty balloon can be inflated, resulting in an unsatisfactory dilatation. One solution to this problem is the autoperfusion catheter - a catheter with proximal side holes, a central lumen coursing through the balloon, and distal side holes and an end-hole. When the balloon is inflated, a pressure gradient is created driving blood through the proximal side holes, through the lumen, and out the distal side holes and end holes, thus delivering oxygenated blood to the distal myocardium [2]. While this device may be useful in certain cases of angioplasty, it does have limitations. For example, if the patient's blood pressure is low, the coronary perfusion pressure also will be low, resulting in less driving force for blood to traverse the proximal side holes. Also if the artery is very narrow, the side holes might occlude. Another approach to the problem is the infusion of oxygenated fluorocarbons through the catheter to the distal myocardium. In fact, Fluosol is FDA approved for this use in the United States.

Our research group had the opportunity to collaborate with the late Dr. Andreas R. Gruentzig, the developer of angioplasty, on an early experimental trial of Fluosol in an angioplasty model [3]. Fluosol (20%) is a 20% weight per volume emulsion of 2 perfluorochemicals, perfluorodecalin and perfluorotripropylamine, emulsified with a detergent, Pluronic F 68, plus egg yolk phospholipids. In this study, anesthetized dogs were subjected to a 60 minute angioplasty balloon inflation in the left anterior descending coronary artery. One group of dogs received a continuous infusion of oxygenated Fluosol (Green Cross Corp, Osaka Japan) through the balloon catheter at a pressure of 40 - 60 mmHg and a flow rate of 50 ml/min in order to perfuse the myocardium supplied by the occluded artery. Dogs in Group 2 received no infusion. Five of five dogs receiving the Fluosol infusion survived; 3 of 5 dogs in the control group developed ventricular fibrillation. When studied by electron microscopy, 72% of fields from biopsies in the control group showed ultrastructural abnormalities consistent with ischemic damage, while only 42% of fields in the treated group showed damage. A mean cell injury grade, based on ultrastructural analysis, was lower in the Fluosol-treated group compared to the control group. The authors concluded that perfusion of the canine left anterior descending artery by oxygenated fluorocarbon distal to balloon occlusion was beneficial. Virmani et. al. [4] studied the effects of the perfluorochemical Fluosol 20% during repeated balloon occlusions of the circumflex artery in anesthetized dogs. Eight 90 second inflations were performed in dogs receiving either Ringer's lactate, oxygenated Fluosol, or no treatment. Electrocardiographic ST segment elevation at 90 seconds of balloon inflation was less in the Fluosol group compared to the Ringer's lactate and no-treatment groups. There was also improved radial shortening assessed by contrast ventriculography and less ultrastructural alterations in the Fluosol group, compared to the other groups.

Several clinical studies assessed the efficacy of intracoronary Fluosol during angioplasty procedures. Anderson et. al. [5] reported that intracoronary perfusion of oxygenated Fluosol (20%) during a 90 second balloon inflation lengthened the time to angina, shortened the duration of angina and lessened the degree of ST segment elevation compared to Ringer's lactate. Cleman et. al. [6] studied 20 patients undergoing angioplasty for left anterior descending coronary artery disease. Standard balloon inflations were first performed followed by balloon inflations with either transcatheter infusion of Ringer's lactate or Fluosol 20% (60 ml/min). Mean PO_2 of the oxygenated Ringer's lactate was 480 mmHg; and of the oxygenated Fluosol was 600 mmHg. Quantitative 2 - dimensional echocardiography was performed using a

chord-shortening technique. Severe regional wall motion abnormalities with greater than a 90% decrease in contraction were observed during either no intracoronary infusion or transcatheter infusion of Ringer's lactate or with nonoxygenated Fluosol. Transcatheter infusion of oxygenated Fluosol resulted in normal left ventricular contraction. The fact that nonoxygenated Fluosol did not have a beneficial effect suggests that in the setting of angioplasty, oxygenated Fluosol's mechanism of action probably is due to increased delivery of oxygen to the myocardium rather than some other mechanism. In a second study by the same laboratory, Jaffe et. al. [7] reported that transcatheter infusion of oxygenated Fluosol 20% preserved left ventricular ejection fraction (53%) during balloon inflation compared to an ejection fraction of 36%, 38%, and 37% for nonperfused, oxygenated Ringer's, and nonoxygenated Fluosol infusion, respectively. The results of a large multicenter study of 245 patients on the use of oxygenated Fluosol during angioplasty was reported by Kent et. al. [8]. Patients were randomized to receive either routine angioplasty or angioplasty with transcatheter oxygenated Fluosol, administered at 60 ml/min. Patients receiving oxygenated Fluosol had severe angina less frequently during angioplasty than those receiving routine angioplasty (21 vs 34%). ST segment shift at deflation was less in patients with Fluosol perfusion (1.7 mm) than with patients who were not perfused (2.2 mm). Ejection fraction during angioplasty was better preserved in the Fluosol-treatment group at 51% compared to the control group (31%). Fluosol also maintained regional wall motion near baseline during balloon inflation, while in untreated patients severe regional wall dysfunction was observed by 2 dimensional echocardiography. Nineteen patients in the routine treatment group developed clinical complications; only 7 developed complications in the Fluosol group. Two patients developed an adverse reaction to a Fluosol test dose (low back pain) and 2 patients had complications during the Fluosol infusion (ventricular fibrillation in one patient and hypotension, dyspnea, and chest pain - possibly due to balloon malfunction). The authors concluded that "transcatheter perfusion with an oxygen carrying perfluorochemical emulsion is effective in alleviating myocardial ischemia during angioplasty and can be safely administered in this patient population."

In summary, both experimental and clinical trials support the use of oxygenated fluorocarbons to protect the ischemic myocardium during angioplasty. As mentioned, Fluosol is approved for this use in the United States. However, this agent probably is not necessary for most angioplasty procedures and it is likely that the agents will be most useful in high risk cases, in cases where the coronary artery to be

dilated supplies a large territory of the ventricle, or in cases where a long inflation time might be needed in order to obtain an optimal dilation.

FLUOROCARBONS AND MYOCARDIAL INFARCTION

Permanent Coronary Occlusion

The use of fluorocarbons as a therapy for acute myocardial infarction is considerably more controversial than their use during angioplasty. While there seems to be little debate that distal perfusion of oxygenated fluorocarbons may protect the myocardium during brief episodes of coronary occlusion induced by balloon inflation, whether fluorocarbons have any clinical benefit during longer periods of ischemia which typify myocardial infarction remains controversial. Initial studies assessed the use of fluorocarbons in a myocardial infarct model of permanent coronary occlusion (that is without reperfusion). Studies by Glogar et. al. [9], performed in anesthetized dogs ventilated with oxygen, showed that volume replacement with the fluorocarbon preparation of Decamine 60 in Pluronic F68 was capable of reducing myocardial infarct size from about 100% of the ischemic risk zone in controls to 70% in dogs receiving the fluorocarbon emulsion. Nunn et. al. [10] administered Fluosol (20%) by exchange transfusion to anesthetized dogs one hour after onset of a six hour coronary artery occlusion of the left anterior descending artery. A second group received exchange transfusion with saline and a third group received no intervention. The percent of the ischemic risk zone which developed necrosis with 88 - 90% in the two controls; in animals who received Fluosol, only 67% of the risk zone developed necrosis. In another study of permanent coronary occlusion in the dog, Biro [11] reported a trend towards less CK release, a marker of myocardial tissue damage, in dogs hemodiluted with Fluosol and an increase in mean blood flow to the ischemic zone in dogs hemodiluted versus those who were not. Kolodgie et. al. [12] studied the effect of Fluosol on infarct morphology in dogs subjected to permanent coronary artery occlusion. Animals received three days of permanent coronary artery occlusion. One group of dogs received an exchange transfusion with Fluosol (40 ml/kg); another with heparinized autologous blood. Both of these groups were ventilated with 100% oxygen. A third group received no therapy. At three days infarct size assessed by histology was smaller in Fluosol dogs (54% of the ischemic risk zone) compared to dogs receiving autologous blood (64%) or controls (79%). Detailed histologic analysis revealed reduced numbers of inflammatory cells, greater sparing of subepicardial and subendocardial tissue, and perfluorochemical particles within the endothelial,

inflammatory cells and necrotic myocytes of the infarct, in the Fluosol - treated animals. In another study of permanent coronary occlusion, Kolodgie showed that Fluosol not only reduced extent of necrosis but also resulted in less inducible ventricular arrhythmias [13]. Reduction in ischemia following acute coronary occlusion was also reported by Faithfull et. al. in a pig model [14]. Mechanisms by which fluorocarbons might have had their beneficial effect in models of permanent occlusion include 1) direct delivery of oxygen to ischemically injured areas where red cells might not penetrate and 2) low viscosity resulting in improved collateral flow during ischemia. As will be discussed below, effects of fluorocarbons on leukocytes and complement may also be important.

Fluorocarbons in Reperfused Infarcts

The 1980's ushered in a new era in the treatment of acute myocardial infarction. Observations made early in that decade showed that the majority of Q-wave myocardial infarcts were associated with thrombotic occlusion of a coronary artery. Early thrombolytic therapy with agents such as streptokinase and tissue plasminogen activator is capable of lysing these coronary thrombi resulting in tissue salvage, improving left ventricular function, and most important, improving survival following acute myocardial infarction. Despite success with thrombolytic agents, there has been an interest in administering adjunctive therapy with the hope of further improving outcome. Administration of fluorocarbons along with reperfusion of acute myocardial infarction has been an area of very active research over the last 6 - 7 years. The majority of the work in this field has been carried out by the laboratories of Forman, Vermani, and Schaer. In 1985, Forman et. al. [15] determined the effects of intracoronary infusion of oxygenated Fluosol versus saline in anesthetized dogs subjected to 90 minutes of proximal left anterior descending coronary artery occlusion followed by 24 hours of reperfusion. Therapy was begun with reperfusion and continued for 20 - 30 minutes. At 24 hours the infarct size as a percentage of the risk region was less in the perfluorochemical treated group (20%) compared to the control group (47%). There was an improvement in ventricular wall motion in the Fluosol group, assessed by contrast ventriculography. Early after reperfusion, regional myocardial blood flow in the previously ischemic zone was improved in the Fluosol group compared to the control group; however by one hour after reperfusion flows did not differ between groups. Because the Fluosol appeared to produce beneficial effects when given only during reperfusion, the authors postulated that "perfluorochemicals

may reduce reperfusion injury." Mechanisms for this might include inhibition of neutrophil function with reduction of subsequent release of oxygen radicals. In fact Fluosol and oxypherol (another perfluorochemical) were shown in invitro studies to suppress neutrophil activation and superoxide release [16, 17]. As mentioned, Kolodgie et. al. [12] had previously shown that Fluosol could reduce neutrophil infiltration in a 3 day permanent coronary artery occlusion model.

Menasche et. al. [18] also published a study in 1985 in which perfluorotributylamine in Pluronic F-68 was administered starting 30 minutes into a three hour proximal coronary artery occlusion followed by reperfusion in dogs. In the control dogs, 81% of the risk region developed necrosis; in perfluorochemical treated dogs, 67% of the risk region developed necrosis. However, the number of animals in each group was relatively small and no statistically significant difference was present between groups. In 1987, another study by Forman et. al. [19] confirmed their earlier work that oxygenated Fluosol 20% given intracoronary could reduce myocardial infarct size when administered during reperfusion. In this study, dogs survived for two weeks following a temporary 90 minute coronary occlusion. Treated dogs demonstrated a greater improvement in radial shortening of the infarct zone at 2 weeks. Importantly, histologic analysis revealed adequate healing of the infarcts. Thus although Fluosol might have reduced so-called reperfusion injury, by inhibiting early neutrophil function, this did not appear to be associated with impaired healing. Subsequent studies from Forman's laboratory suggested that fluorocarbons preserved both structural and functional integrity of the endothelium following an episode of ischemia and reperfusion [20 -22]. Since activated neutrophils may mediate endothelial damage by release of oxygen radicals and other toxins, it was logical to suggest that fluorocarbons, by inhibiting neutrophil activation might then preserve endothelium during reperfusion and that this might contribute to salvage of the myocardium. In one study from this lab, Bajaj et. al. [22] subjected closed chest dogs to 90 minutes of coronary artery occlusion followed by 24 hours of reperfusion. Either Fluosol or Ringer's lactate were given intravenously over 30 minutes just prior to reperfusion. In this study, in which animals were ventilated with room air, Fluosol reduced infarct size expressed as a percentage of the risk zone from 25% in controls to 7% in treated animals. This was associated with improved wall motion of the infarct zone. Indium-111 labeling studies revealed less neutrophil demargination and infiltration into the ischemic zone. The endothelial cells were better preserved in the

Fluosol group compared to the control group. In vitro leukocyte studies revealed that at one hour after reperfusion neutrophils from Fluosol treated animals had impaired chemotactic ability and reduced lysozyme release. However, there was no difference in superoxide anion production between groups. Babbitt et. al. [23] observed that Fluosol pretreatment of neutrophils suppressed their adherence to either normoxic or anoxic isolated endothelial cells. Pretreatment of the endothelial cells did not inhibit neutrophil adherence, suggesting that Fluosol's beneficial effects were due to interaction with neutrophils, rather than endothelium. The detergent, Pluronic F68, used to emulsify the perfluorocarbon did not affect neutrophil adherence. Also neutrophils stimulated by lectins had reduced release of lysozymes after incubation with Fluosol. A report by Kolodgie in which the anatomic zone of "no-reflow" was measured with the fluorescent dye, thioflavin-S, showed that intracoronary Fluosol 20% given during reperfusion reduced the area of no reflow and number of capillaries plugged with neutrophils [24]. Forman recently showed [25] that a low dose of intravenous Fluosol reduced peripheral neutrophil count and function, associated with a reduction of infarct size. These studies thus support the concept that Fluosol inhibits neutrophil activation, resulting in less endothelial damage and less reperfusion injury including less no reflow. However, the concept of reperfusion injury remains controversial [26] and whether "no-reflow" actually contributes to myocyte cell death is not resolved. Also, it is possible that any agent that reduces myocardial infarct size by any mechanism will result in less neutrophil accumulation and activation in the heart and less no-reflow. That is, it is possible that fluorocarbon preparations reduce infarct size by some other mechanism and the reduced neutrophil accumulation and endothelial damage are only secondary phenomena. Work by Schaer et. al. [27] has confirmed the basic finding of Forman's that reperfusion with Fluosol can reduce infarct size in the canine model. In their study closed chest dogs received a 90 minute angioplasty balloon coronary occlusion. In a Fluosol-treated group, the balloon remained inflated for an additional 15 minutes during which oxygenated perfluorocarbon was administered into the occluded coronary artery. Control dogs had simple balloon deflation at 90 minutes. At one week, the percent of the risk zone that developed necrosis was 51% in the controls versus 27% in Fluosol-treated animals. There were no differences in hemodynamics between groups. Similar to the studies of Forman there was improvement in regional ventricular function in the treated group. The authors concluded that the oxygenated perfluorochemicals reduced reperfusion injury. While many recent studies have examined the effects of Fluosol

in ischemia/reperfusion models in the dog, studies from Virmani's lab have confirmed that intravenous Fluosol (20%) can reduce infarct size in a rabbit model of 30 minutes of coronary occlusion followed by reperfusion [28, 29]. In these studies Fluosol treatment began at 20 minutes into coronary occlusion or at the time of reperfusion and continued for 20 minutes into reperfusion. A dose dependent reduction of infarct size was observed. Infarct size reduction was observed with doses of 20 ml/kg - 30 ml/kg of Fluosol. As in the canine model, neutrophil infiltration was significantly decreased in all treated groups [28] and there was no inhibition of healing or excess wall thinning at 7 or 14 days [29].

Perhaps one of the most intriguing recent studies is one by Schaer's group [30] which demonstrated that a detergent component used with fluorocarbons, Poloxamer 188, was capable of reducing infarct size in a canine coronary artery occlusion/reperfusion model. This effect may be through neutrophil activation or beneficial rheologic changes [31]. Preliminary results from our laboratory also suggest that the vehicle or detergent may be active in reducing ischemia/reperfusion injury. If these studies are confirmed in the future; it may be that the emulsifiers are more important than the perfluorocarbons themselves in infarct/reperfusion models. Of note, most previous studies which examined the effect of perfluorochemicals such as Fluosol (20%) on myocardial infarct size used saline or Ringer's lactate as the control infusion. Because of this, few studies have examined the emulsifiers alone; however it appears that study of the emulsifiers may become a major area of future investigation. These agents might work by alteration of neutrophil function, alteration of the complement system, or perhaps by improving viscosity and increasing coronary collateral blood flow. The readers are encouraged to see a recent excellent review on the issue of myocardial reperfusion injury and perfluorochemical emulsions [32].

PERFLUOROCARBONS AS ADJUNCTIVE THERAPY TO REPERFUSION IN MAN

The first clinical trial of the use of Fluosol in patients with acute myocardial infarct was reported in 1991 by Forman et. al. [33]. Twenty-six patients who presented within 4 hours of a first anterior wall myocardial infarction received either emergency angioplasty or angioplasty followed by a 30 minute intracoronary infusion of Fluosol (20%) oxygenated to a partial pressure of oxygen of ≥ 500 mmHg. Infarct size was assessed by thallium imaging and regional wall motion by left ventriculography. In patients receiving Fluosol, there was a trend towards higher global ejection fraction at 12 days (54% vs 42%, $p=NS$). There was a significantly

greater increase in chord shortening (a measure of regional wall motion) in the Fluosol group at 12 days (23%) compared to controls (8%). Infarct size estimated from thallium perfusion defects and expressed as a percentage of the left ventricle was smaller in the Fluosol group (3.5%) compared to angioplasty alone (18%). This is really the first clinical trial suggesting that reperfusion injury may occur in man and that pharmacologic therapy with intracoronary Fluosol could reduce that injury. However, a preliminary report from the TAMI - 9 study, a multicenter study of intravenous Fluosol coupled with thrombolysis, failed to show a beneficial effect of Fluosol on survival, reinfarction, recurrent ischemia, infarct size or global left ventricular function [34]. Nevertheless, a large intracoronary Fluosol trial coupled with reperfusion is planned.

In summary - perfluorochemical preparations have been shown to reduce myocardial infarct size when given in experimental models of reperfused infarcts. Several laboratories have suggested that this effect is related to reducing reperfusion injury possibly by inhibition of neutrophils. One lab suggested that this effect is specific to perfluorochemical and not the detergent. However, another laboratory has recently suggested that the detergent alone and not the perfluorochemical may be the active ingredient. One pilot study suggested that oxygenated fluorocarbons given with reperfusion for acute myocardial infarction reduced infarct size and improved regional left ventricular function. Data from a large clinical intravenous trial of Fluosol was essentially negative. Whether perfluorochemical preparations will play an important role in treating patients with acute myocardial infarction, remains to be determined.

SUMMARY

Fluosol (20%) is currently approved for delivering oxygen distal to an occluding coronary angioplasty balloon during brief coronary occlusions. Probably, the majority of routine angioplasty procedures do not require this therapy; however it appears that there are a subset of unstable and high risk patients who will especially benefit from intracoronary Fluosol during angioplasty [35]. Despite one promising small pilot-study [33] a large multicenter study [34] did not suggest that Fluosol had important treatment benefits over control reperfusion, in the clinical treatment of acute myocardial infarction.

REFERENCES

1. S Oesterle, AC Eisenhauer. Interventional Cardiology in The Guide to Cardiology 2nd edition; RA Kloner. LeJacq Communications, New York, pages 241-259 (1990).
2. ZG Turi, S Rezkalla, CA Campbell, RA Kloner. Amelioration of ischemia during angioplasty of the left anterior descending coronary artery with an autoperfusion catheter. *Am. J. Cardiol* 62:513-517 (1988).
3. CS Roberts, HV Anderson, AA Carboni, AGS Justicz, PP Leimgruber, RA Kloner, AR Gruentzig. Usefulness of intracoronary infusion of fluorocarbon distal to prolonged coronary occlusion by angioplasty balloons in dogs. *Am J. Cardiol* 57:1202-1205 (1986).
4. R Virmani, FD Kolodgie, A Osmialowski, P Zimmerman, W Mergner, MB Forman. Myocardial protection by perfluorochemical infusion during transient ischemia produced by balloon coronary occlusion. *Am Heart J* 116:421-431 (1988).
5. HV Anderson, PP Leimgruber, GS Roubin, DL Nelson, AR Gruentzig. Distal coronary artery perfusion during percutaneous transluminal coronary angioplasty. *Am Heart J* 110:720-726 (1985).
6. M Cleman, CC Jaffe, D Wohlgelernter. Prevention of ischemia during percutaneous transluminal coronary angioplasty by transcatheter infusion of oxygenated Fluosol DA 20%. *Circulation* 74:555-562 (1986).
7. CC Jaffe, D Wohlgelernter, H Cabin, L Bowman, L Deckelbaum, M Remetz, M Cleman. Preservation of left ventricular ejection fraction during percutaneous transluminal coronary angioplasty by distal transcatheter coronary perfusion of oxygenated Fluosol DA 20%. *Am Heart J.* 115:1156-1164 (1988).
8. KM Kent, MW Cleman, MJ Cowley, MB Forman, CC Jaffe, M Kaplan, SB King, M Krucoff, T Lassar, B McAuley, R Smith, C Wisdom, D Wohlgelernter. Reduction of myocardial ischemia during percutaneous transluminal coronary angioplasty with oxygenated fluosol. *Am J. Cardiol* 66:279-284 (1990).
9. DH Glogar, RA Kloner, J Muller, LWV DeBoer, E Braunwald. Fluorocarbons reduce myocardial ischemic damage after coronary occlusion. *Science.* 211:1439-1441 (1981).
10. GR Nunn, G Dance, J Peters, LH Cohn. Effect of fluorocarbon exchange transfusion on myocardial infarction size in dogs. *Am J. Cardiol* 52:203-205 (1983).
11. GP Biro. Effect of hemodilution with dextran, stroma-free hemoglobin solution and fluosol - DA on experimental myocardial ischemia in the dog. *Biblhca haemat.* No.47; 54-69 (1981).

12. FD Kolodgie, AK Dawson, MB Forman, R Virmani. Effect of perfluorochemical (Fluosol --DA) on infarct morphology in dogs. *Virchows Arch [Cell Pathol]* 50:119-134 (1985).
13. FD Kolodgie, AK Dawson, DM Roden, MB Forman, R Virmani. Effect of Fluosol-DA on infarct morphology and vulnerability to ventricular arrhythmia. *Am. Heart J* 1192-1200 (1986).
14. NS Faithfull, W Erdman, M Fennema et. al. Effects of hemodilution with fluorocarbons or dextran on oxygen tensions in acutely ischemic myocardium. *Br. J. Anaesth* 58: 1031-1040 (1986).
15. MB Forman, S Bingham, H Kopelman, C Wehr, MP Sandler, F Kolodgie, WK Vaughn, GC Friesinger, R Virmani. Reduction of infarct size with intracoronary perfluorochemical in a canine preparation of reperfusion. *Circ.* 71:1060-1068 (1985).
16. R Virmani, D Warren, R Rees, LM Fink, D English. Effects of perfluorochemical on phagocytic function of leukocytes. *Transfusion* 23: 512-525 (1983).
17. R Virmani, LM Fink, K Gunter, D English. Effect of perfluorochemical blood substitutes on human neutrophil function. *Transfusion* 24:343-347 (1984).
18. P Menasche, M Escorsin, P Birkui, A Lavergne, M Fauchet, P Commin, P Lorente, RP Geyer, A Piwnica. Limitations of fluorocarbons in reducing myocardial infarct size. *Am J. Cardiol* 55:830-834 (1985).
19. MB Forman, DW Puett, BH Wilson, WK Vaughn, GC Friesinger, R Virmani. Beneficial long-term effect of intracoronary perfluorochemical on infarct size and ventricular function in a canine reperfusion model. *J. Am Coll Cardiol* 9:1082-1090 (1987).
20. MB Forman, DW Puett, SE Bingham, R Virmani, MV Tantengco, RT Light, A Bajaj, R Price, G Friesinger. Preservation of endothelial cell structure and function by intracoronary perfluorochemical in a canine preparation of reperfusion. *Circulation* 76:469-479 (1987).
21. MB Forman, DW Puett, R Virmani. Endothelial and myocardial injury during ischemia and reperfusion: Pathogenesis and Therapeutic Implications. *J. Am. Coll Cardiol.* 13:450-459 (1989).
22. AK Bajaj, MA Cobb, R Virmani, JC Gay, RT Light, MB Forman. Limitation of myocardial reperfusion injury by intravenous perfluorochemicals. Role of neutrophil activation. *Circulation* 79:645-656 (1989).
23. DG Babbitt, MB Forman, R Jones, AK Bajaj, RL Hoover. Prevention of neutrophil-mediated injury to endothelial cells by perfluorochemical. *Am J. Pathol.* 136:451-459 (1990).

24. FD Kolodgie, R Virmani, A Farb, CL Hart. Limitation of no reflow injury by blood-free reperfusion with oxygenated perfluorochemical (Fluosol-DA 20%). *J. Am. Coll. Card.* 18:215-223 (1991).
25. MB Forman, CJ Pitarys, H Vildibill, TL Lambert, DA Ingram, R Virmani, JJ Murray. Pharmacologic perturbation of neutrophils by fluosol results in a sustained reduction in infarct size in the canine model of reperfusion. *J. Am. Coll. Cardiol.* 19:205-216 (1992).
26. RA Kloner, K Przyklenk, P Whittaker. Deleterious effects of oxygen radicals in ischemia/reperfusion. Resolved and unresolved issues. *Circulation* 80:1115-1127 (1989).
27. GL Schaer, SP Karas, EC Santoian, C Gold, MC Visner, R Virmani. Reduction in reperfusion injury by blood free reperfusion after experimental myocardial infarction. *J. Am. Coll. Cardiol.* 15:1385-1393 (1990).
28. HE Rice, R Virmani, CL Hart, FD Kolodgie, A Farb. Dose-dependent reduction of myocardial infarct size with the perfluorochemical Fluosol - DA. *Am. Heart J* 120:1039-1046 (1990).
29. R Virmani, FD Kolodgie, AF Osmialowski, MB Forman. The effect of perfluorochemical fluosol-DA (20%) on myocardial infarct healing in the rabbit. *Am J. Cardiovasc. Pathol.* 3:69-80 (1990).
30. GL Schaer, TL Hursey, R Rodriguez, DR Campbell, JK Song, NC Monabat, V Thota, and JE Parrillo. Poloxamer 188, a component of perfluorochemical emulsion (Fluosol) reduces myocardial infarct size in dogs. *Circulation* 84 (Suppl II): II-619 (Abstract) (1991).
31. GL Schaer, TL Hursey, R Rodriguez, EA Tifler, BM Ennis, V Thota, NC Monabat, JE Parrillo. Polaxamer 188, a hemorheologic agent, reduces experimental myocardial infarct size: importance for prolonged therapy for reperfusion injury. *J. Am Coll. Cardiol.* 19:334A (1992).
32. MB Forman, DA Ingram, JJ Murray. Attenuation of myocardial reperfusion injury by perfluorochemical emulsions. *Clinical Hemorheology* 12:121-140 (1992).
33. MB Forman, JM Perry, BH Wilson, MS Verrani, PR Kaplan, FA Shawl, GC Friesinger. Demonstration of myocardial reperfusion injury in humans: Results of a pilot study utilizing coronary angioplasty with perfluorochemical in anterior myocardial infarction. *J. Am Coll. Cardiol.* 18:911-918 (1991).
34. TC Wall, EJ Topol, RM Califf, J Blankenship, D Talley, M Tannenbaum, G Gacioch, M Cohen, M Sanz, J Leimberger. TAMI 9: Preliminary report of a prospective randomized trial of intravenous fluosol in acute myocardial infarction. *Circulation* (Suppl I) 86:I-642 (1992).
35. MJ Cowley, FR Snow, G DiSciascio, K Kelly, C Guard, JV Nixon. Perfluorochemical perfusion during coronary angioplasty in unstable and high-risk patients. *Circulation* 81 (Suppl IV): IV:27-IV-34 (1990).

**CARDIOVASCULAR APPLICATIONS OF FLUOROCARBONS:
CURRENT STATUS AND FUTURE DIRECTION -
A CRITICAL CLINICAL APPRAISAL**

**J. David Ogilby, M.D.
Philadelphia Heart Institute
Presbyterian Medical Center
Philadelphia, Pennsylvania, USA**

Abstract: Alteration of normal blood flow to the heart may result in myocardial ischemia or infarction. Perfluorochemical emulsions offer a potential means to improve oxygenation of the heart during periods of hypoxia. The small particle size and linear disassociation curve of perfluorochemicals may result in greater oxygen delivery than blood particularly in severely diseased or damaged atherosclerotic vessels.

Intracoronary Fluosol given during PTCA reduces the myocardial ischemia which occurs during balloon inflation. Although Fluosol does not prevent myocardial dysfunction during prolonged balloon inflations, new concentrated perfluorochemicals have increased oxygen delivery capacity and may have greater benefit. Experimentally, during coronary occlusions, perfluorochemicals promote higher oxygen tension in areas of ischemia and result in infarct size reduction. Reduction of oxygen free radicals has been proposed as the mechanism by which Fluosol exerts its ability to reduce infarct size. Clinical studies with Fluosol and thrombolytic therapy for treatment of acute myocardial infarctions are ongoing to assess ability to preserve myocardial function. Perfluorochemical cardioplegia can deliver oxygen during periods of cardiac arrest and may improve immediate post CPB myocardial function particularly in those patients with pre-existing left ventricular dysfunction. The oxygen-carrying capacity of perfluorocarbons and its unique properties offer great advantages to improve the treatment of cardiovascular diseases.

The myocardium is exquisitely sensitive to alterations in oxygen delivery. The coronary epicardial vessels supply the nutrients necessary for normal myocardial contractile function. Normal systolic shortening of the

myocyte is replaced by systolic bulging after 1 - 2 minutes of coronary occlusions.[1] Longer periods of myocardial ischemia which occur during coronary artery spasm or acute thrombosis result in permanent myocardial ischemia and necrosis. After 40 minutes of coronary occlusion, subendocardial necrosis has begun with complete transmural injury occurring within 4 to 24 hours depending upon animal species and presence of collaterals.[2] The use of the oxygen-carrying capacity of perfluorocarbon emulsions has been evaluated during brief periods of ischemia such as during balloon angioplasty,[3] during intermittent periods of moderate ischemia,[4] or during prolonged periods of myocardial ischemia and reperfusion.[5,6] Because of the high oxygen solubility and small particle size, perfluorocarbon emulsions may have improved oxygen delivery in settings of myocardial ischemia.

FLUOROCARBON USE DURING PTCA

Intracoronary administration of Fluosol is a FDA approved adjunct to conventional angioplasty, but is used in only a fraction of 600,000 angioplasties performed annually. Examination of the clinical results utilizing Fluosol in the angioplasty population may give partial explanation for these findings.

The initial report of 20 patients undergoing PTCA of the left anterior descending artery showed preservation of wall motion during the administration of oxygenated Fluosol.[7] The goal of distal perfusion during coronary angioplasty was to enhance the safety of those patients undergoing interventional revascularization, prolong the duration of balloon inflation, and improve the rate of restenosis. Balloon angioplasty is known to result in enlargement of the vessel lumen and disruption of the intima.[8] As the subintimal tear heals with fibroblast migration, excessive fibroblast proliferation may lead to exaggerated healing response and restenosis. Restenosis varies upon lesion site, coronary artery dilated, clinical factors and occurs currently between 30 and 50%.[9]

Other studies with Fluosol administration during experimental PTCA showed delayed appearance of wall motion abnormalities compared to

untreated controls, but the preservation of wall motion and myocardial function was less than if arterial blood was infused rather than Fluosol.[10] This same group examined regional myocardial lactate extraction which is preserved when oxygen delivery is adequate and found that lactate extraction was maintained only via blood perfusion and lactate production, not extraction, occurred during administration of Fluosol. Myocardial lactate metabolism was also studied during Fluosol infusion in patients undergoing PTCA.[11] Although myocardial function was preserved during Fluosol infusion compared to control, lactate production occurred during Fluosol infusion implying inadequate oxygen delivery. A large multi-center randomized trial examined Fluosol administration in 245 angioplasty patients.[12] Patients treated with Fluosol had less ST segment changes and angina than control patients but did not greatly alter overall clinical outcome. The above studies show that Fluosol infusion during PTCA provides inadequate oxygen delivery to allow prolonged balloon inflation. As most PTCA patients can tolerate 90 -180 seconds of balloon inflation without distal perfusion, the duration of balloon inflation is not prolonged by Fluosol infusion.

Old technology balloons with higher profile and larger guide wire diameter are necessary for fluorocarbon infusion and increase the difficulty of PTCA being performed. New PTCA balloons which are routinely employed have reduced profile, enhanced tractability, utilize small guide wires (.010 - .014 inches), and are not capable of adequate distal infusion of blood or fluorocarbon.

Second generation of Fluorocarbons have increased oxygen carrying capacity and may be able to deliver more oxygen at lower infusion rates. Second generation fluorocarbon emulsion, such as Oxygent™, a perflubron emulsion [13,14], has been studied in experimental angioplasty models. A 90% W/V perflubron emulsion was studied in a canine angioplasty model with distal coronary perfusion occurring during LAD occlusion.[15] As opposed to earlier studies[16] which showed that Fluosol administration at 30 cc/min did not preserve myocardial function as well as blood perfusate,

perflubron infusion at 24 ml/min was able to maintain normal systolic function in the ischemic zone during a two minute coronary occlusion. Flow was limited to 24 ml/min in part because of the high viscosity of the emulsion. Newer emulsions, which are 60 w/v perflubron, are currently being evaluated for PTCA application.

Despite the clinical studies in favor of Fluosol administration during angioplasty, advances in catheter technology have deterred further use of Fluosol clinically during angioplasty. An autoperfusion balloon catheter was developed to allow passive myocardial perfusion during balloon inflation through a central lumen with multiple side holes in the shaft proximal and distal to the balloon.[17] Blood delivery using the autoperfusion balloon is dependent upon the patient having adequate blood pressure. Of more interest, 15 minute PTCA perfusion balloon inflations which are longer in duration than could occur during Fluosol infusion, do not alter clinical restenosis following angioplasty. Prolonged perfusion balloon inflations have dramatically enabled salvaging of failed PTCAs and prevented emergency CABG surgery.[18]

In selected high risk angioplasty candidates with ejection fractions of less than 30%, or in those patients with a large area of muscle at risk for left ventricular dysfunction, fluorocarbon infusion during angioplasty may increase the safety of the patient undergoing angioplasty.[19] Only a small percentage of the 600,000 PTCA patients might benefit from improved oxygen delivery during that angioplasty. The clinical use of Fluosol infusion during PTCA balloon inflation is limited by amount of oxygen delivery, failure of prolonged inflations to impact on restenosis, non-compatibility with new generation PTCA catheters.

FLUOROCARBON UTILITY IN REPERFUSION OF ISCHEMIC MYOCARDIUM

Early reperfusion of an evolving infarction has been shown to limit myocardial necrosis and preserve ventricular contractile function, thereby reducing cardiac mortality.[20,21] However, the introduction of oxygen, calcium and cellular elements, particularly neutrophils to the ischemic myocardium, may initiate deleterious cascade which limits myocardial salvage

after reperfusion.[22,23,24] The process of reperfusion causing further myocyte damage has been termed "reperfusion injury".[25]

Fluorocarbon Cardioplegia

Controlled reperfusion of globally arrested hearts occurs clinically during open heart surgery. Hypothermic, hyperkalemic crystalloid cardioplegia provides excellent protection during aortic cross-clamping required for open heart surgery[26] and is not improved by the addition of fluorocarbon during routine CABG.[27]

However, when prolonged periods of ischemia occur prior to emergency open heart surgery, additional protection may be beneficial.[28] Both the Fluosol cardioplegia and blood cardioplegia significantly enhanced recovery of systolic shortening compared to reperfusion with normal blood following 2 hours of left anterior descending occlusion.[27] Tissue ATP levels were better preserved by blood cardioplegia compared to Fluosol cardioplegia. The investigators questioned whether the oxygen carrying capacity of Fluosol is adequate to repay the oxygen debt which occurs during prolonged periods of ischemia. Other groups have examined the difference between Fluosol containing cardioplegia and blood cardioplegia and found that both maintain preservation of stroke work index following periods of ischemic arrest.[28] However, blood cardioplegia showed better metabolic preservation by maintaining the ability for lactate *utilization* as opposed to lactate *production* in the Fluosol cardioplegic group. The addition of substrate enhancement such as aspartate/glutamate-enriched perfluorochemical cardioplegia has also been shown to offer additional myocardial preservation following 12 hours of global hypothermic ischemia in neonatal piglet hearts.[28]

Following routine open heart surgery, fluorocarbon enriched cardioplegia appears as adequate as crystalloid or blood cardioplegia. However, following prolonged myocardial ischemia, both fluorocarbon cardioplegia and blood cardioplegia provide individual benefits by modifying the reperfusion of the myocardium. Blood cardioplegia may provide increased oxygen delivery[25] while Fluosol cardioplegia supplies oxygen

without the potentially detrimental neutrophils, platelets or other blood components.[29]

Reperfusion During an Acute Myocardial Infarction

Reperfusion of ischemic myocardium also occurs during opening of occluded epicardial vessels during a myocardial infarction. The role of fluorocarbons in reperfusion of acute myocardial infarction has been investigated in animal models. Intravenous Fluosol administration in a dog model of coronary occlusion with reperfusion was shown to significantly reduce the amount of myocardium undergoing necrosis[5] (see Figure 1). A similar reduction of myocardial infarct size was also seen in a rabbit model with intravenous Fluosol administration but only when animals were treated with 20 - 30 ml/kg of Fluosol.[30] The mechanism of reduction in reperfusion injury by Fluosol has in part been attributed to inhibition of neutrophil chemotaxis and enhanced oxygen tissue delivery. Reperfusion of ischemic myocardial with neutrophil depleted blood also has been shown to reduce infarct size.[31]

Recent data show the beneficial effect of Fluosol, independent of oxygen delivery, providing further evidence supporting neutrophil inhibition as the mechanism of protection.[32,33] Complement and platelets have also been shown to decrease with Fluosol administration, thus suggesting other factors aside from neutrophil depletion, as being mediators of reducing reperfusion injury.[34]

Clinical studies have been initiated to examine the ability of Fluosol to improve myocardial salvage in patients with acute myocardial infarction.[6] The initial pilot study (N=12) randomized patients with an acute myocardial infarction and documented total occlusion of the left anterior descending artery, to direct myocardial infarction PTCA vs. direct myocardial infarction PTCA plus Fluosol infusion. The rationale for using patients in the process of acute myocardial infarction was to insure Fluosol delivery occurred in the setting of myocardial ischemia and Fluosol would be infused prior to blood reperfusion. Regional wall motion shortening was improved in the 6 patients treated with direct PTCA and Fluosol infusion compared to direct PTCA

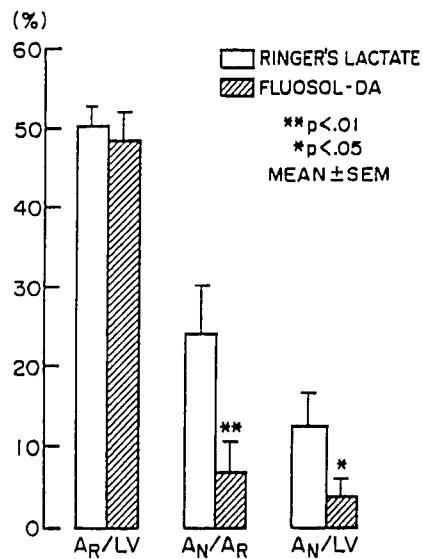

FIGURE 1: The amount of myocardium undergoing necrosis (A_N) expressed as a percent of the area at risk (A_R) or total left ventricle (LV) is shown for both treatment groups. From ref. [5]. (Reproduced by permission from the authors).

controls (see Figure 2). These findings need to be substantiated in larger study groups.

The clinical role of IV Fluosol administration was investigated in TAMI 9, a randomized trial of 430 patients treated with thrombolytic therapy for an acute myocardial infarction.[35] Patients with acute myocardial infarction were given standard thrombolytic therapy then randomized to receive Fluosol or no Fluosol and followed for clinical endpoints. Fluosol was given at a total dose of 15 ml/kg and 100% oxygen was delivered through a non-rebreather mask. Results showed that left ventricular ejection fraction was not improved in the Fluosol treated group when compared to controls. When regional wall motion was examined in the subset of patients with anterior myocardial infarctions, a possible trend towards improvement was noted.

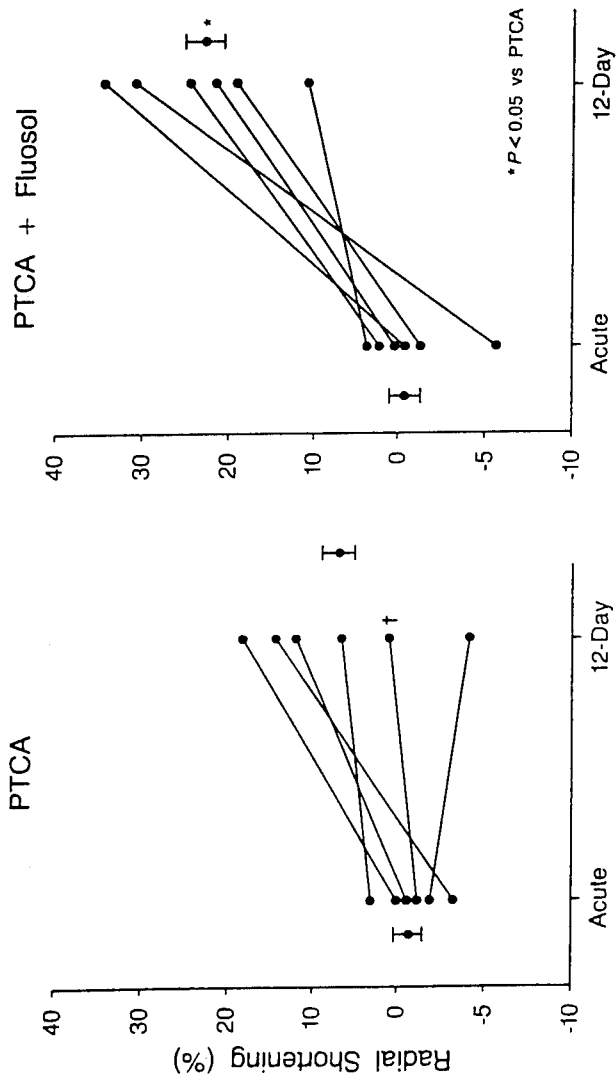

FIGURE 2: Radial shortening for individual patients treated with angioplasty (PTCA) or angioplasty plus Fluosol is shown. Although most patients demonstrated improved regional ventricular function at 12 days, adjunctive therapy with Fluosol resulted in a significantly greater improvement. Wall motion assessed on radionuclide ventriculogram. From ref. [6]. (Reproduced by permission from the authors).

Despite the animal experimental data showing strong support for the ability of Fluosol to limit infarct size, in this first clinical study, IV Fluosol given in conjunction with thrombolytic therapy for an acute myocardial infarction did not improve the overall clinical outcome of patients. Limitations of study design may have adversely affected patient outcome and prevented showing any clinical improvement. If blood products are reperfused into the ischemic zone prior to the initiation of IV Fluosol, the potential benefit of Fluosol may be offset by the entry of blood into the region of myocardial necrosis. Furthermore, IV thrombolytic therapy results in recanalization in only 60 - 70% of patients, thus patients receiving Fluosol may not have reperfused clinically. Fluosol randomization occurred after the administration of thrombolytic therapy, thereby increasing the possibility of blood reperfusion prior to Fluosol. Finally, the sample size may have been insufficient to determine clinical differences between the two groups. The experimental animal data shows a protective benefit of Fluosol reperfusion with prolonged myocardial ischemia which might be demonstrated in larger clinical trials.

FUTURE OF CARDIOVASCULAR APPLICATIONS OF FLUOROCARBONS

Percutaneous Transluminal Coronary Angioplasty

The use of Fluosol or second generation fluorocarbon infusion during routine angioplasty will remain at its current low level, given the current cumbersome methods by which fluorocarbons need to be delivered by the larger outdated angioplasty catheters. The ability of autoperfusion balloon to deliver blood simply via the perfusion pressure of the patient has obviated the need for distal infusion in some patients.

Emergency PTCA of an infarct related coronary artery requires prompt delivery to a hospital with a 24 hour standby catheterization team. When such facilities are available, direct myocardial infarction PTCA has been proven beneficial. Direct myocardial infarction PTCA with infusion of Fluosol offers an ideal delivery of fluorocarbons into the ischemic myocardium while an inflated PTCA balloon prevents normal blood products from entering the ischemic zone. The experimental animal evidence and the

limited clinical studies strongly suggest Fluosol infusion via distal PTCA balloon for direct reperfusion of an acute myocardial infarction will be beneficial with decreased myocardial necrosis and improved myocardial preservation.

Although the initial clinical study failed to show myocardial salvage with IV Fluosol after thrombolytic therapy for an acute myocardial infarction, a larger study may show other fluorocarbons. Fluorocarbons with higher oxygen saturation may result in greater tissue salvage and warrant further investigation.

Emergency Coronary Artery Bypass Grafting

Following failed angioplasties or in those patients with known coronary artery disease who were brought emergently to the operating room with active ischemia, fluorocarbon-enriched cardioplegia may reverse the ischemic processes which were initiated with acute coronary insufficiency.

Oxygen-Carrying Contrast Agent

Perflubron has a bromine atom present which is radiodense. The radiodensity of perflubron can be enhanced by the addition of conventional iodine contrast agents to create an oxygen-carrying compound that will give adequate cineangiography pictures of epicardial coronary vessels while maintaining PO_2 of 450 mmHg.

With improved oxygen delivery and simplified handling characteristics, fluorocarbon administration will become more widespread in selected cardiovascular patients. Earlier estimates of cardiovascular usage may have been overly optimistic, however, areas of definite clinical benefit of cardiovascular administration of fluorocarbons have been or are being determined. The cardiologist will learn which groups may benefit most from the administration of fluorocarbons.

REFERENCES

1. R. Tennant and C.J. Wiggers, The effect of coronary occlusion on myocardial contractions, *Am J Physiol* 112, 351 (1935).
2. K.A. Reimer, J.E. Lowe, M.M. Rasmussen and R.B. Jennings, The wavefront phenomenon of ischemic cell death. I. Myocardial infarct

- size vs. duration of coronary occlusion in dogs. *Circulation* 56, 786 (1977).
3. C.S. Roberts, H.V. Anderson, A.A. Carboni, A.G.S. Justicz, P.P. Leimgruber, R.A. Kloner and A.R. Gruentzig, Usefulness of intracoronary infusion of fluorocarbon distal to prolonged coronary occlusion by angioplasty balloon in dogs, *Am J Cardiol* 57, 1202-1205 (1986).
 4. J.T. Flaherty, J.H. Jaffin, G.J. Magovern Jr., K.R. Kanter, T.J. Gardner, M.V. Miceli and W.E. Jacobus, Maintenance of aerobic metabolism during global ischemia with perfluorocarbon cardioplegia improves myocardial preservation. *Circulation* 69, 585-592 (1984).
 5. A.K. Bajaj, M.A. Cobb, R. Virmani, J.C. Gay, R.T. Light and M.B. Forman, Limitation of myocardial reperfusion injury by intravenous perfluorochemicals: Role of Neutrophil Activation, *Circulation* 79, 645-656 (1989).
 6. M.B. Forman, J.M. Perry, B.H. Wilson, M.S. Verani, P.R. Kaplan, F.A. Shawl and G.C. Friesinger, Demonstration of myocardial reperfusion injury in humans: Results of a pilot study utilizing acute coronary angioplasty with perfluorochemical in anterior myocardial infarction, *J Am Coll Cardiol* 18, 911-918 (1991).
 7. M. Cleman, C.C. Jaffe and D. Wohlgeleitner, Prevention of ischemia during percutaneous transluminal coronary angioplasty by transcatheter infusion of oxygenated Fluosol DA 20%, *Circulation* 74(3), 555-562 (1986).
 8. D.P. Faxon, V.J. Weber, C.C. Haudenschild, S.B. Gottsman, W.A. McGovern and T.J. Ryan, Acute effects of transluminal angioplasty in three experimental models of atherosclerosis, *Atherosclerosis* 2, 125-133 (1982).
 9. J.W. Hirshfeld, J.S. Schwartz, R. Jugo, R.G. MacDonald, S. Goldberg, M.P. Savage, T.A. Bass, G. Vetrovec, M. Cowley, A.S. Taussig, H.B. Whitworth, J.R. Margolis, J.A. Hill, C.J. Pepine and the M-Heart Investigators, Restenosis after coronary angioplasty: A multivariate statistical model to relate lesion and procedure variables to restenosis, *J Am Coll Cardiol* 18, 647-656 (1991).
 10. H. Tokioka, A. Miyazaki, P. Fung, R.E. Rajagopalan, S. Kar, S. Meerbaum, E. Corday and J.K. Drury, Effects of intracoronary infusion of arterial blood or Fluosol-DA 20% on regional myocardial metabolism and function during brief coronary artery occlusions, *Circulation* 75(2), 473-481 (1987).
 11. L.H. Young, C.C. Jaffe, J. H. Revkin, P.H. McNulty and M. Cleman, Metabolic and functional effects of perfluorocarbon distal perfusion during coronary angioplasty, *Am J Cardiol* 65, 986-990 (1990).
 12. K.M. Kent, M.W. Cleman, M.J. Cowley, M.B. Forman, C.C. Jaffe, M. Kaplan, S.B. King III, M.W. Krucoff, T. Lassar, B. McAuley, R. Smith, C. Wisdom and D. Wohlgeleitner, Reduction of myocardial

- ischemia during percutaneous transluminal coronary angioplasty with oxygenated Fluosol®, *Am J Cardiol* 66, 279-284 (1990).
13. J.G. Riess, J.L. Dalfors, G.K. Hanna, D.H. Klein, M.-P. Krafft, T.J. Pelura and E.G. Schutt, Development of highly fluid, concentrated and stable fluorocarbon emulsions for diagnosis and therapy. *Biomater. Art. Cells and Immob Biotech* 20, 839-842 (1992).
 14. J.G. Riess, Overview on progress in the fluorocarbon approach to in vivo oxygen delivery, in *Blood Substitutes and Oxygen Carriers*, T.M.S. Chang ed., Marcel Dekker, Inc., New York, 1993, 24-43.
 15. J.D. Ogilby, S. Noma, G. DiLoretto and G. Stets, Preservation of myocardial function during ischemia with intracoronary perfluoroocetyl bromide (Oxygent™), in *Blood Substitutes and Oxygen Carriers*, T.M.S. Chang ed., Marcel Dekker, Inc., New York, 1993, 728-732.
 16. C.W. Christensen, W.C. Reeves, T.A. Lassar and D.H. Schmidt, Inadequate subendocardial oxygen delivery during perfluorocarbon perfusion in a canine model of ischemia, *Am Heart J* 115, 30-37 (1988).
 17. P.J. Quigley, T. Hinohara, H.R. Phillips, R.H. Peter, V.S. Behar, Y. Kong, C.A. Simonton, J.A. Perez and R.S. Stack, Myocardial protection during coronary angioplasty with an autoperfusion balloon catheter in humans, *Circulation* 78, 1128-1134 (1988).
 18. J.E. Smith, P.J. Quigley, J.E. Tchong, R.P. Bauman, J. Thomas and R.S. Stack, Can prolonged perfusion balloon inflations salvage vessel patency after failed angioplasty?, *Circulation* 80 (Suppl II), II-373 (1989).
 19. M.J. Cowley, F.R. Snow, G. DiSciascio, K. Kelly, C. Guard and J.V. Nixon. Perfluorochemical perfusion during coronary angioplasty in unstable and high-risk patients, *Circulation* 81(suppl IV), IV27-IV34 (1990).
 20. J. Kennedy, J. Ritchie, K. Davis and J. Fritz, Western Washington randomized trial of intracoronary streptokinase in acute myocardial infarction, *N Engl J Med* 309, 1477-1482 (1983).
 21. Gruppo Italiana Per Lo Studio Della Streptokinase Nell Infarcto Miocardico (GISSI), Effectiveness of intravenous thrombolytic treatment in acute myocardial infarction, *Lancet* 1, 397-401 (1986).
 22. D.J. Hearse, Reperfusion of the ischemic myocardium, *J Mol and Cell Cardiol* 9, 605-616 (1977).
 23. R.L. Engler, G.W. Schmid-Schoenbein and R.S. Pavelec, Leukocyte capillary plugging in myocardial ischemia and reperfusion in the dog, *Am J Pathol* 111, 98-111 (1983).
 24. R.L. Engler, M.D. Dahlgren, D.D. Morris, M.A. Peterson and G.W. Schmid-Schoenbein, Role of leukocytes in response to acute myocardial ischemia and reflow in dogs, *Am J Physiol* 251, H314-H322 (1986).

25. E. Braunwald and R.A. Kloner, Myocardial reperfusion: A double-edged sword?, *J Clin Invest* 76, 1713-1719 (1985).
26. D.M. Follette, K. Fey, G.D. Buckberg, J.J. Helly, D.L. Steed, R.P. Foglia and J.V. Mahoney, Reducing postischemic damage by temporary modification of reperfusate calcium, potassium, pH, and osmolarity, *J Thorac Cardiovasc Surg* 82, 221-238 (1981).
27. C. Acar, M.T. Partington and G.D. Buckberg, Studies of controlled reperfusion after ischemia: XIX. Reperfusate composition: Benefits of blood cardioplegia over Fluosol DA cardioplegia during regional reperfusion - Importance of including blood components in the initial reperfusate, *J Thorac Cardiovasc Surg* 101, 284-293 (1991).
28. S.M. Martin, H. Laks, D.C. Drinkwater, D.G. Stein, S.W. Barthel, E.R. Capouya, J.M. Pearl, S. Bhuta, B. Ho and P. Chang, Perfluorochemical reperfusion limits myocardial reperfusion injury after prolonged hypothermic global ischemia, in *Blood Substitutes and Oxygen Carriers*, T.M.S. Chang ed., Marcel Dekker, Inc., New York, 1993, 738-742.
29. J.M. Pearl, H. Laks, D.C. Drinkwater, A. Meneshian, S.M. Martin, M. Curzan and P.A. Chang, Fluosol cardioplegia results in complete functional recovery: A comparison with blood cardioplegia, *Ann Thorac Surg* 54, 1144-50 (1992).
30. H.E. Rice, R. Virmani and C.L. Hart, F.D. Kolodgie and A. Farb, Dose-dependent reduction of myocardial infarct size with the perfluorochemical Fluosol-DA, *Am Heart J* 120, 1039-1046 (1990).
31. M.R. Litt, R.W. Jeremy, H.F. Weisman, J.A. Winkelstein and L. C. Becker, Neutrophil depletion limited to reperfusion reduces myocardial infarct size after 90 minutes of ischemia: Evidence for neutrophil-mediated reperfusion injury, *Circulation* 80, 1816-1827 (1989).
32. J.V. Vitola, T.W. Rigsby, D.A. Ingram, J.B. Atkinson, J.J. Murray and M.B. Forman, The beneficial effect of Fluosol® to reduce myocardial reperfusion injury is independent of its oxygen carrying ability, *J Am Coll Cardiol* 21, 399A (1993).
33. G.L. Schaer, T.L. Hursey, E.R. Rodriguez, D.R. Campbell, J.K. Song, N.C. Manabat, V. Thota and J.E. Parrillo, Poloxamer 188, a Component of perfluorochemical emulsion (Fluosol®), reduces myocardial infarct size in dogs, *Circulation* 84 (Suppl II), II-619 (1991).
34. M.B. Forman, C.J. Pitarys, H.D. Vildibill, T.L. Lambert, D.A. Ingram, R. Virmani and J.J. Murray, Pharmacologic perturbation of neutrophils by Fluosol results in a sustained reduction in infarct size in the canine model of reperfusion, *J Am Coll Cardiol* 19, 205-216 (1992).

35. T.C. Wall, E.J. Topol, R.M. Califf, J. Blankenship, D. Talley, M. Tannenbaum, G. Gacioch, M. Cohen, M. Sanz, J. Leimberger for the TAMI 9 Study Group, TAMI 9: Preliminary report of a prospective randomized trial of intravenous Fluosol in acute myocardial infarction, *Circulation* 86 (Suppl I), I-642 (1992).

PERFLUOROCHEMICAL EMULSIONS AND RADIATION THERAPY

Sara Rockwell, Ph.D.

Department of Therapeutic Radiology

Yale University School of Medicine

333 Cedar Street, New Haven, CT 06510 USA

Solid malignancies are supported by abnormal, deficient vascular beds. Transient and chronic interruptions in blood flow subject some regions in solid tumors to a range of environmental deficiencies, including severe hypoxia. Because O_2 is a potent radiosensitizer, hypoxic tumor cells are resistant to radiation and limit the response of tumors to single doses of radiation, fractionated radiotherapy, and brachytherapy. Perfluorochemical emulsions (PFC-E) offer an effective approach for transporting O_2 at high partial pressures and delivering O_2 to tumor regions which would otherwise be hypoxic. Appropriate combinations of PFC-E and O_2 , carbogen, or hyperbaric oxygen improve tumor oxygenation, assessed by microelectrodes, ^{31}P -MRS, cytochrome aa3 oxidation, or hemoglobin saturation, and produce concomitant changes in tumor radiosensitivity. A variety of PFC-E, with different formulations, improve the response of experimental tumors to radiation, without compromising the radiation tolerance of critical normal tissues. These studies suggest that adequately intensive regimens using appropriate PFC-E as adjuncts to radiotherapy could improve the treatment of patients with cancer.

INTRODUCTION

As the malignant cells of solid tumors proliferate, they invade, compress, and obliterate the blood vessels which originally supported the tissue. Although neovascularization occurs, the new blood vessels are usually abnormal and

disorganized. The defective vasculature within tumors results in shunting, retrograde flow, stasis, and other abnormalities in blood flow [1,2]. Tumors therefore contain regions in which transient interruptions of blood flow or chronic perfusion deficits lead to the development of hypoxia and a variety of other environmental inadequacies [3-6]. Hypoxia develops early in the course of tumor growth—even microscopic tumors have significant numbers of hypoxic cells [3]. Because malignant cells are selected for their ability to survive in adverse microenvironments during the subclinical development of neoplasms, most macroscopic tumors contain significant numbers of viable, hypoxic cells. In most rodent tumors and human tumor xenografts, 10-20% of the viable tumor cells are radiobiologically hypoxic [3,6]; there is increasing evidence that human tumors contain similar proportions of hypoxic cells [5].

Hypoxia protects against radiation because O_2 participates in the complex chain of chemical reactions which lead from the deposition of radiation energy to the production of cytotoxic DNA damage. Because these chemical reactions are complete within a few milliseconds after irradiation, O_2 must be present *during* irradiation to act as a radiosensitizer and need not be present either before or after radiation treatment. Very low levels of O_2 are needed for effective radiosensitization [7]. The half-maximum for sensitization occurs at a pO_2 of only 3 torr. The radiosensitizing effect of O_2 saturates at oxygen concentrations similar to those in venous blood (20-40 torr); cells at these oxygen tensions have radiosensitivities virtually indistinguishable from cells equilibrated with air, 100% O_2 , or hyperbaric oxygen. Because of this, most normal tissues exhibit full, or nearly complete, aerobic radiosensitivity. In contrast, solid tumors contain areas with oxygen levels low enough to produce partial or complete hypoxic radioresistance.

Because severely hypoxic cells are approximately three times more resistant to radiation than aerobic cells, even very small numbers of hypoxic cells will dominate the response of the tumors to large doses of radiation. Hypoxic cells have been shown to limit the response of experimental tumors to intensive, potentially curative, treatments with large single doses of radiation, fractionated radiotherapy, or the continuous low-dose-rate irradiations used in brachytherapy [3,4,6]. Although data from clinical trials are less clear and convincing, there is increasing evidence that hypoxic cells limit the response of some human tumors to conventional radiotherapy regimens, and that the

outcome of cancer therapy can be improved in certain diseases by the use of treatment regimens designed to circumvent the protective effects of hypoxia [5].

This paper reviews studies performed by our group over the past decade [7-27], which have examined the hypothesis that perfluorochemical emulsions can be used to deliver O₂ at high partial pressures to solid tumors, thereby oxygenating tumor cells which would otherwise be hypoxic and improving the outcome of radiation therapy.

MATERIALS AND METHODS

The studies reviewed here were performed using EMT6 mammary tumors in BALB/c Rw mice and BA1112 rhabdomyosarcoms in WAG/rij Y rats. These tumors were selected because they normally contain significant and well-defined proportions of viable hypoxic cells, which determine the response of the tumors to intensive irradiation [3]. These tumors have been used extensively to study the effects of radiosensitizers, bioreductive alkylating agents, altered fractionation patterns, and brachytherapy. The techniques used in these studies are detailed in the primary publications [12,14,15,17,19,21]. Experiments were performed in full compliance with all applicable animal welfare regulations. Three PFC-E were examined in the studies reviewed here: Fluosol[®], an emulsion containing 14% w/v perfluorodecalin and 6% w/v perfluorotripropylamine [10,17] and FMIQ, a 20% w/v perfluoro-N-methyldecahydroisoquinoline emulsion [26] from Alpha Therapeutic Corp. and Oxygent[™] CA, a 90% w/v perflubron emulsion (perfluorooctylbromide [PFOB]) [23-25] from Alliance Pharmaceutical Inc. These emulsions and the non-PFC-containing 'vehicle' emulsion corresponding to Oxygent were graciously provided by the respective companies, without cost, for our studies.

RESULTS

Several series of experiments examined the effects of PFC-E on the radiobiological hypoxic fractions of EMT6 and BA1112 tumors [12,17,23-26]. In these studies, the PFC-E was administered by slow intravenous injection, and the animals then breathed oxygen, carbogen (95% O₂/5% CO₂) or hyperbaric oxygen (HBO; 100% O₂ at 3 ATA) before and throughout the

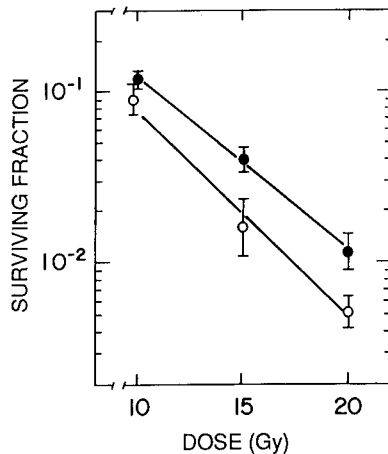

FIGURE 1. Survival of cells in EMT6 tumors treated with x-rays alone (●) or in combination with 15 ml/kg FMIQ plus carbogen (○). Error limits on all Figs. are SEM's. Lines shown on all figures were fitted by regression analyses [3]. Reprinted from [26].

irradiations. The combinations of PFC-E plus these O₂-enriched atmospheres altered the tumor cell survival curves, as illustrated on Fig. 1-4, in a manner consistent with that expected theoretically from a decrease in the proportion of hypoxic cells within the tumors (a detailed consideration of the mathematics and assumptions of this analysis is beyond the scope of this review, and can be found elsewhere [3]). The PFC-E had no effects on the radiosensitivity of tumors in N₂-asphyxiated animals and small or no effects on tumors in air-breathing animals (Fig. 2; Table I). No effects were seen in animals injected with saline or the non-PFC-containing vehicle emulsion (Fig. 2 and 3; Table I). Carbogen, O₂, or HBO alone had no effects in EMT6 tumors (Fig. 2, Table I) and small effects in BA1112 tumors (Fig. 3 and 4). Thus, a maximal change in the hypoxic fraction required the use of both the PFC-E and the oxygen-enriched atmosphere, as would be expected from theoretical considerations of O₂ transport by these emulsions and by blood [11]. Analogous effects were seen in 2 different tumor models, in 2 different species of rodents, and with three different emulsions having very different compositions and formulations. Overall, these data show that the

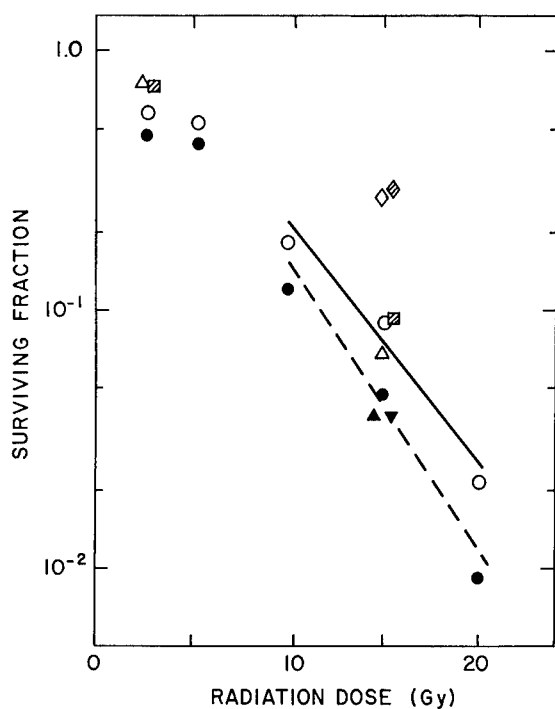

FIGURE 2. Survival of cells in EMT6 tumors treated with x-rays alone (O), or in combination with 15 ml/kg Fluosol plus carbogen for 30 min before and during irradiation (●). Several controls are also shown: treatment with Fluosol and carbogen 5 (▲) or 60 (▼) min before irradiation; air-breathing, Fluosol treated mice (⊞); carbogen breathing, saline injected mice (Δ). N₂-asphyxiated, saline-injected mice (◇). N₂-asphyxiated, Fluosol injected mice (◊). Reprinted from [12].

oxygenation and radiation response of solid tumors can be increased by the use of PFC-E and O₂, that change this requires the presence of the O₂-carrying perfluorochemical, and that this sensitization is not unique to any particular formulation or to any unique component of a specific emulsion.

The dose of PFC-E injected influenced the magnitude of the improvement in radiation response. Sensitization first increased with increasing PFC-E dose and increasing fluorocrit (Fig. 3) [12,14-17,23,24]. At very high PFC-doses,

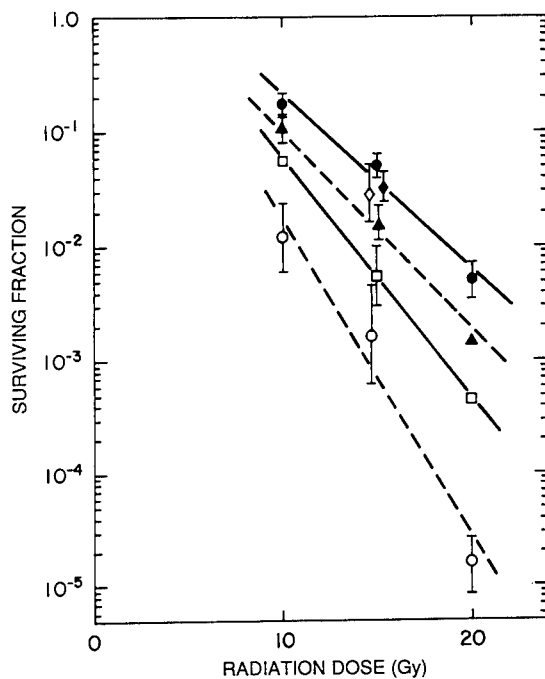

FIGURE 3. Survival of cells in BA1112 tumors treated with x-rays alone (●) or in combination with carbogen breathing (▲), 4 ml/kg Oxygent plus carbogen (□), 10 ml/kg Oxygent plus carbogen (○), or vehicle plus air (◆) or carbogen (◇). Reprinted from [23].

radiosensitivity plateaued or decreased, possibly reflecting the limits of the improved O_2 delivery and diffusion within tumors [11] and the hemodynamic perturbations produced by very large doses of PFC-E. At optimal fluorocrits, the exact timing of the PFC-E, O_2 , and radiation treatments were not critical; times of 5 min to 1 hr between PFC-E injection [and beginning of O_2] and irradiation produced similar results (Fig. 2) [12,14,15,17]. With longer times, the decrease in fluorocrit was paralleled by a decrease in efficacy [15,17].

An extensive series of experiments was performed to verify that the observed changes in the radiobiological hypoxic fractions of the tumors did indeed reflect changes in tumor oxygenation. In one series of experiments [22], the

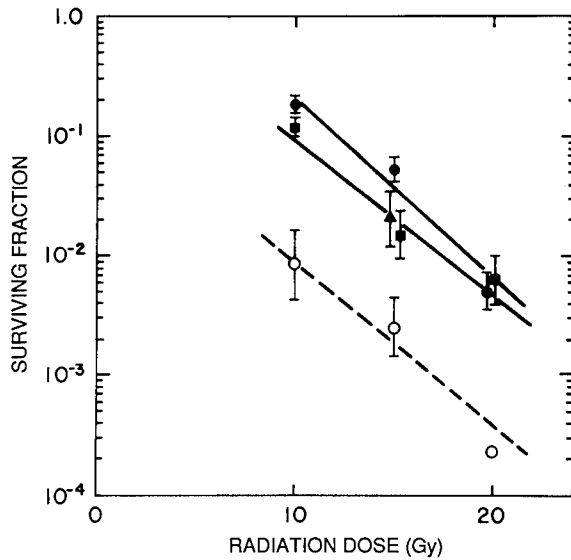

FIGURE 4. Survival of cells in BA1112 tumors treated with x-rays alone (●), x-rays plus HBO (■), 4 ml/kg vehicle plus HBO (▲), or 4 ml/kg Oxygent plus HBO (○). Reprinted from [24].

TABLE I

Atmosphere	Emulsion		
	None	10 ml/kg Vehicle	10 ml/kg Oxygent
Air	.053 (.043 - .066)	.054 (.033 - .088)	.051 (.037 - .070)
O ₂	.046 (.036 - .058)	.059 (.050 - .070)	.035 (.026 - .045)
N ₂	.21 (.18 - .25)	.18 (.15 - .21)	.18 (.14 - .23)

Effect of the atmosphere and injectant on the survival of cells from EMT6 tumors irradiated with 15 Gy. Surviving fractions are geometric means of 3-10 independent determinations; numbers in parentheses are upper and lower standard errors. None of the experimental manipulations altered the viability of cells in unirradiated EMT6 tumors.

oxygenation of BA1112 rhabdomyosarcomas was systematically assessed using a variety of different techniques. Tissue pO_2 was measured using glass micro-Clark electrodes. Hemoglobin saturation and the redox state of cytochrome aa3 were measured using optical spectrophotometry. Magnetic resonance spectroscopy (^{31}P -MRS) was used to assess tissue energy metabolism and tissue pH. These studies showed that treatment of BA1112 tumors with a PFC-E (Oxygent) plus an oxygen-enriched atmosphere improved the oxygenation of the tumors, as assessed by polarographic electrodes, changes in hemoglobin saturation, and changes in cytochrome aa3 reduction, and also produced the changes in the ^{31}P spectra which would be expected from improved oxygenation (i.e., increased PCr/Pi, NTP/Pi, and PDE/Pi ratios). Controls treated with Oxygent plus air or N_2 and controls breathing O_2 , air, or N_2 but not receiving Oxygent were assessed concomitantly to examine the effects of each manipulation separately. The combination of Oxygent plus O_2 breathing was needed to produce maximal improvements in tumor oxygenation; this finding is in agreement with the radiation response studies described above.

Glass micro-Clark electrodes were also used to assess regional oxygenation in EMT6 tumors [23]. In these tumors, neither Oxygent alone nor carbogen-breathing alone produced statistically significant changes in the distribution of oxygen tensions within the tumors, but the combination of Oxygent plus carbogen produced a statistically significant decrease in the proportion of radiobiologically hypoxic areas. This finding is in agreement with radiation response data for this tumor [23].

These studies show that treatment of EMT6 and BA1112 tumors with Oxygent plus an oxygen-enriched atmosphere improves tumor oxygenation; the observed changes in tumor oxygenation are compatible with those expected from analyses of the radiation dose response curves for the tumor cells. These findings therefore support the theoretical rationale underlying the use of PFC-E as adjuncts to radiotherapy.

Other past and ongoing research in our own and other laboratories is addressing the next question: i.e. whether PFC-E can be used practically and safely as effective adjuncts to the fractionated radiation regimens and protracted brachytherapy regimens used in radiotherapy. Radiation therapy is

generally delivered as many small radiation doses given over several weeks of treatment. It is therefore important to assess whether PFC-E are also effective when given with smaller radiation doses, with multi-fraction irradiation, and with the protracted irradiations used in brachytherapy. A variety of studies in our own laboratory and by others show that PFC-E, given in adequate doses with sufficient frequencies, do improve the response of rodent tumors to fractionated and protracted treatment regimens more closely resembling those used in clinical radiotherapy (Fig. 5) [4,12,19,20,21,25].

Radiobiologists generally have not examined the toxicities of PFC-E given as single agents in intensive, protracted regimens, because this is better assessed through standard toxicologic studies. However, many radiobiologists have asked whether administration of PFC-E and oxygen would increase the toxicity of radiation to the critical normal tissues which limit the intensity of radiation therapy. These studies have shown that PFC-E do not increase significantly the toxicity of radiation to skin, hematopoietic progenitor cells, lung, or intestine [12,19,20,24], probably because these normal tissues are already well oxygenated and therefore cannot be sensitized further by the increased O_2 delivered by the PFC-E. Detailed studies examining the growth, and metastases of tumors treated with PFC-E have also been performed [12,13,19]. These studies provide no indication that the regimens of PFC-E and oxygen treatment proposed for use with radiotherapy would increase the growth rate, aggressiveness, or metastatic potential of tumors. In summary, these laboratory studies support the hypothesis that the use of PFC-E as adjuncts to radiotherapy should not promote tumor growth or increase the toxicity of radiation to the normal tissues of the patients. Thus, appropriate use of a PFC-E as an adjunct to radiotherapy should increase the effectiveness of radiotherapy, without similarly increasing the adverse side effects of the treatment, thereby increasing the therapeutic ratio and improving the outcome of therapy.

DISCUSSION

Our laboratory studies reviewed here, and similar studies from other laboratories, support the hypothesis that appropriately intensive treatments with PFC-E, combined with carbogen, oxygen, or HBO can be used to improve the oxygenation of solid tumors and thereby improve the response of tumors to radiation therapy and that this can be done without concomitantly

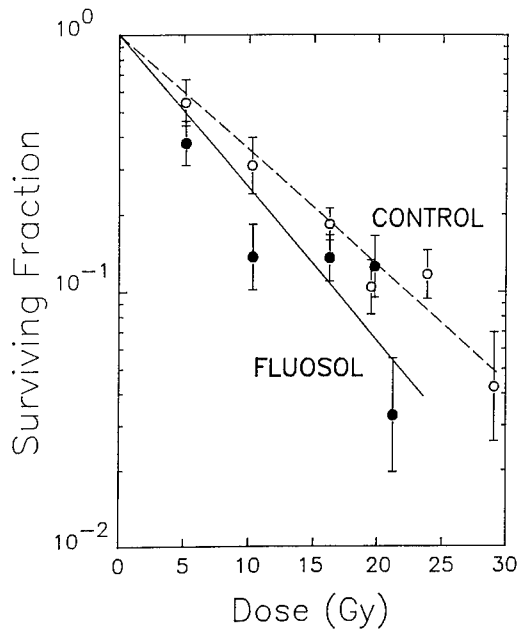

FIGURE 5. Survival of cells in BA1112 tumors treated with brachytherapy at a dose rate of ~ 1 Gy/hr. Radiation was given alone (O) or in combination with a single injection of 15 ml/kg Fluosol just before irradiation, plus carbogen throughout irradiation (●). Reprinted [21].

augmenting the toxicity of the treatment. Although clinical trials testing Fluosol as an adjunct to radiotherapy were, unfortunately, terminated at total PFC-doses too low to test the efficacy of this approach rigorously [27], these trials do support the animal studies in suggesting that this combination can be given safely to patients with cancer. The use of PFC-E as adjuncts to radiotherapy differs markedly from most other potential applications of these emulsions. An optimal regimen would *fully* oxygenate *every* hypoxic tumor cell throughout *each* radiation treatment. Because radiotherapy is generally administered as a series of brief (1-5 min) x-ray treatments given daily over ~ 6 weeks or as low-dose-rate brachytherapy treatments given over periods of days or weeks, the development of emulsions and regimens which will allow an approximation of this ideal represents a formidable challenge.

ACKNOWLEDGEMENTS

The studies reviewed here were supported in large part by Grant CA-35215 from the NCI. These studies reflect the contributions of the many scientists listed as authors of the papers reviewed here, as well as the ideas and efforts of the investigator preparing this review.

REFERENCES

1. R.K. Jain. *Cancer Res.* **48**:2641-2658 (1988).
2. P. Vaupel, F. Kallinowski, and P. Okunieff. *Cancer Res.* **49**:6449-6465 (1989).
3. J.E. Moulder and S. Rockwell. Vol. 5 (I.J. Fidler and G. Poste, Eds.) pp. 313-341, Martinus Nijhoff Publishing, Boston (1987).
4. J.E. Moulder, J. Dutreix, S. Rockwell, and D.W. Siemann. *Int. J. Radiat. Oncol. Biol. Phys.* **14**:913-927 (1988).
5. S. Rockwell. *Semin. Oncol.* **19**:29-40 (1992).
6. S. Rockwell and J.E. Moulder. *Int. J. Radiat. Oncol. Biol. Phys.* **19**:197-202 (1990).
7. S. Rockwell. *Biomater. Artif. Cells Artif. Organs* **16**:519-532 (1988).
8. S. Rockwell, J.J. Fischer, D.F. Martin, and B.A. Teicher. *Cell Tissue Kinet.* **16**:621 (1983).
9. B.A. Teicher and S. Rockwell. *PAACR* **24**:267 (1983).
10. S. Rockwell. *Int. J. Radiat. Oncol. Biol. Phys.* **11**:97-103 (1985).
11. J.J. Fischer, S. Rockwell, and D.F. Martin. *Int. J. Radiat. Oncol. Biol. Phys.* **12**:95-102 (1986).
12. S. Rockwell, T.P. Mate, C.G. Irvin, and M. Nierenburg. *Int. J. Radiat. Oncol. Biol. Phys.* **12**:1315-1318 (1986).
13. S. Rockwell, C.G. Irvin, and M. Nierenburg. *Clin. Exptl. Metastasis* **4**:45-50 (1986).
14. D.F. Martin, E.A. Porter, S. Rockwell, and J.J. Fischer. *Int. J. Radiat. Oncol. Biol. Phys.* **13**:747-751 (1987).
15. D.F. Martin, E.A. Porter, J.J. Fischer, and S. Rockwell. *Radiat. Res.* **112**:45-53 (1987).
16. S. Rockwell. *Biomater. Artif. Cells Artif. Organs* **16**:519-532 (1988).

17. S. Rockwell, C.G. Irvin, and M. Kelley. *Int. J. Radiat. Oncol. Biol. Phys.* 15:913-920 (1988).
18. S. Rockwell. *Exp. Gerontol.* 24:37-48 (1989).
19. S. Rockwell and M. Kelley. *Radiother. Oncol.* 14:49-53 (1989).
20. S. Rockwell. *Cancer Communication* 3:97-114 (1989).
21. J.D. Morton, E.A. Porter, H. Yabuki, R. Nath, and S. Rockwell. *Radiat. Res.* 124:178-182 (1990).
22. H.D. Sostman, D. Matwed, S. Rockwell, G. Cofer, A.L. Sylvia, H.C. Charles, R. Negro-Vilar, and D. Moore. *Mag. Res. Med.* 20:253-267 (1991).
23. S. Rockwell, M. Kelley, C.G. Irvin, C.S. Hughes, E. Porter, H. Yabuki, and J.J. Fischer. *Radiother. and Oncol.* 22:92-98 (1991).
24. S. Rockwell, C.G. Irvin, M. Kelley, C.S. Hughes, H. Yabuki, E. Porter, and J.J. Fischer. *Int. J. Radiat. Oncol. Biol. Phys.* 22:87-93 (1991).
25. S. Rockwell, M. Kelley, C.G. Irvin, C.S. Hughes, H. Yabuki, E. Porter, and J.J. Fischer. *Biomater. Artif. Cells Immobilization Biotechnol.* 20:883-893 (1992).
26. S. Rockwell, M. Kelley, and C.G. Irvin. *Int. J. Radiat. Biol.* 6:833-839 (1992).
27. S. Dowling, J.J. Fischer, and S. Rockwell. *Biomater. Artif. Cells Immobilization Biotechnol.* 20:903-905 (1992).

COMBINATION OF PERFLUORO-CHEMICAL EMULSIONS AND CARBOGEN BREATHING WITH CANCER CHEMOTHERAPY

B. A. Teicher

Dana-Farber Cancer Institute and Joint Center for Radiation Therapy, 44 Binney Street, Boston, MA 02115

ABSTRACT

Over the past ten years several laboratories have explored the use of perfluorochemical emulsions (PFCE) and carbogen (95% O₂/5% CO₂; C) or oxygen breathing as an adjuvant to radiation therapy and/or chemotherapy in solid tumor model systems. The rationale for the use of PFCE and C or oxygen breathing in this therapeutic setting is that solid tumor masses contain areas of hypoxia which are therapeutically resistant. Since x-rays and many chemotherapeutic agents require oxygen to be maximally cytotoxic and most normal tissues are well-oxygenated, the additional oxygen put in circulation by the PFCE/C should not increase the normal tissue toxicities produced by the various therapies. Several anticancer agents are dependent on oxygen to be cytotoxic, these drugs such as the iron-chelating peptide bleomycin are enhanced in antitumor activity by the co-administration of a PFCE/C. The antitumor alkylating agents especially cyclophosphamide, BCNU and melphalan show increased tumor cell killing without a concomitant increase in bone marrow toxicity when administered with PFCE/C. Enhanced activity was also observed when topoisomerase II inhibitors such as adriamycin and etoposide were co-administered with PFCE/C. Positive effects, although smaller, were observed when antimetabolites such as 5-fluorouracil and methotrexate were co-administered with PFCE/C.

INTRODUCTION

It is difficult to cure most solid tumors by treatment with nonsurgical therapeutic modalities. Intrinsic resistance of the tumor cells to treatment agents provides a partial explanation for treatment failure [1-3]; heterogeneity in several physiological

properties of solid tumors resulting from inadequate and non-uniform vascularization is also a contributing factor [4-9].

Hypoxic cells in solid tumors are presumed to be an obstacle to successful cancer treatment, because these cells are relatively protected from the cytotoxic effects of radiotherapy and certain anticancer drugs [6, 7, 10]. The importance of hypoxic cells in limiting the curability of human tumors is still a controversial issue, although some clinical and laboratory data strongly suggest that hypoxic cells are a cause of *in vivo* treatment failure [11-16].

The level of cellular oxygenation is an important factor in the action of many antineoplastic agents, several of which have been classified *in vitro* [7] and *in vivo* [17] by their selective cytotoxicity toward oxygenated and hypoxic tumor cells. The perfluorochemical emulsion, Fluosol-DA and carbogen breathing have been shown to enhance the activity of the antitumor alkylating agents including CDDP [17-19] carboplatin, cyclophosphamide [17, 19, 20], thioTEPA [21], BCNU [22, 23] and L-PAM [19, 24-26].

This short review will focus on the anticancer drug cyclophosphamide. Cyclophosphamide is one of the most widely used anticancer drugs because a broad range of human tumors respond to cyclophosphamide, including malignant lymphoma, leukemia, multiple myeloma, neuroblastoma, retinoblastoma, sarcoma and carcinomas of the ovary, testis, breast and lung [27, 28].

Cyclophosphamide is a prodrug which undergoes a complex metabolism *in vivo*. 4-Hydroxycyclophosphamide is the initial metabolite formed after administration of cyclophosphamide [29, 30] and phosphoramidate mustard is probably the major biologically active alkylating species derived from cyclophosphamide [31]. The cytotoxicity of cyclophosphamide toward Hoechst 33342 fluorescently selected subpopulations of the FSaII murine fibrosarcoma was investigated to determine the effect of physiological factors on the drug [17]. The 10% brightest cells were assayed as putative normally oxygenated cells near the tumor vasculature and the 20% dimmest as putative hypoxic cells distal from the vasculature of the tumor. A single therapeutic dose of cyclophosphamide resulted in the largest differential killing between bright and dim cells (6.3-fold bright > dim) of any of the 18 anticancer therapies tested [17]. The result was interpreted as reflecting primarily the ability of short-lived alkylating species derived from cyclophosphamide to penetrate through cell layers in the tumor.

Tumor Oxygen Measurements. Tissue oxygen measurements were made using a pO₂-Histograph (Eppendorf, Inc., Hamburg, Germany). The polarographic needle microelectrode was calibrated

in aqueous solutions saturated with air or 100% nitrogen. The electrode was used for tumor measurements if there was less than 1% variation in current measurements upon repetition of the calibration cycle. For tumor pO_2 measurements, the animal was anesthetized by an i.p. injection of Ketaset (35 mg/kg) and xylazine (25 mg/kg). Oxygen tensions were measured in the rat 13672 mammary carcinoma under normal air and carbogen breathing conditions prior to and after i.v. administration of the perflubron emulsion (8 ml/kg) (**TABLE 1**). Under normal air breathing conditions the 13672 tumor has a broad range of oxygenation with a higher mean pO_2 (12.3 mmHg) than median pO_2 (5.8 mmHg) indicating skewing toward more hypoxic values. The oxygenation of this tumor was markedly increased by carbogen breathing such that the mean and median pO_2 's were increased about 3-fold. Administration of the perflubron emulsion and maintenance of air breathing did not alter the oxygen profile of the tumor compared with the oxygen profile obtained under normal air breathing conditions. The addition of carbogen breathing to administration of the perflubron emulsion increased the mean pO_2 of the tumor compared carbogen breathing but did not alter the median pO_2 of the tumor compared with carbogen breathing.

Twenty-four hrs. after administration of a single dose of cyclophosphamide (300 mg/kg, i.p.) the oxygen profile of the tumor showed a loss of the most oxygenated readings such that the mean pO_2 was now 4 mmHg and the median pO_2 was essentially 0 mmHg (**TABLE 1**). While carbogen breathing increased the oxygenation of the tumor to levels near that obtained with air breathing in the untreated tumor, the values were lower than those obtained in the untreated tumor with carbogen breathing. Although administration of the perflubron emulsion with air breathing did not alter the oxygenation of the tumor compared with air breathing alone, administration of the perflubron emulsion along with carbogen breathing markedly increased both the mean and median pO_2 's of the tumors compared with normal air breathing.

At 48 hrs. after administration of the cyclophosphamide (300 mg/kg, i.p.) the tumors were still very hypoxic with no change in the mean pO_2 (3.8 mmHg) and a small increase in the median pO_2 (0.7 mmHg) compared with the mean and median pO_2 's at 24 hrs. post drug administration (**TABLE 1**). Carbogen breathing increased the oxygenation of the tumors at 48 hrs. post cyclophosphamide administration to the same levels obtained at 24 hrs. post cyclophosphamide administration. Treatment with the perflubron emulsion and maintenance of normal air breathing did not increase the oxygenation of the tumor but the addition of carbogen breathing to administration of the perflubron emulsion increased the mean pO_2 of the tumor to 2-fold the level obtained

TABLE 1. Oxygenation parameters for the rat 13672 mammary carcinoma under several conditions with no treatment and 24 hrs. and 48 hrs. after i.p. administration of a single dose of cyclophosphamide (300 mg/kg).

Measurement condition	Mean/Median	% of pO ₂ readings <5 mmHg	pO ₂ , mmHg percentiles	
	pO ₂ mmHg		10th	90th
air	11.3/4.9	52	0.0	34
carbogen	31.6/15.1	42	0.0	81
Perflubron Emulsion, 8 ml/kg				
air	11.0/4.7	50	0.0	38
carbogen	46.4/18.7	32	0.0	121
24 hrs. post Cyclophosphamide (300 mg/kg)				
air	4.0/0.0	82	0.0	23
carbogen	17.4/4.0	54	0.0	51
Perflubron Emulsion, 8 ml/kg				
air	5.6/0.0	79	0.0	28
carbogen	29.1/9.7	37	0.0	65
48 hrs. post Cyclophosphamide (300 mg/kg)				
air	3.8/0.7	74	0.0	20
carbogen	17.4/6.4	48	0.0	50
Perflubron Emulsion, 8 ml/kg				
air	2.4/0.0	76	0.0	20
carbogen	35.4/6.5	42	0.0	113

with carbogen breathing alone and the median pO₂ to the same level obtained with carbogen breathing alone.

At 24 hrs. after cyclophosphamide administration the portion of the tumors that was severely hypoxic (pO₂ < 5 mmHg) increased from 52% in the tumors with no treatment to 82% in the tumors treated with cyclophosphamide (**TABLE 1**). By 48 hrs. after cyclophosphamide the severely hypoxic portion of the tumors was 74% indicating that reoxygenation was occurring very slowly. Carbogen breathing reduced the severely hypoxic portion of the tumors to 42% prior to treatment and after treatment with cyclophosphamide restored the severely hypoxic portions of the tumors to 54% at 24 hrs. and to 48% at 48 hrs. after cyclophosphamide administration. Finally, administration of the perflubron emulsion and carbogen breathing resulted in a severely hypoxic percentage of 32% in the tumors without treatment, 37% in the tumors at 24 hrs. after cyclophosphamide administration and 42% in the tumors at 48 hrs. after cyclophosphamide administration.

Increase in Therapeutic Response. The tumor cell survival assay allows quantitative determination of the tumor cell (and bone marrow) killing effect of a treatment administered to tumor-bearing animals. Treatment of mice bearing FSaII fibrosarcoma with various doses of cyclophosphamide produced increasing tumor cell killing with increasing dose of the drug (**TABLE 2**). The addition of the perflubron emulsion at doses of 12 ml/kg or 8 ml/kg along with 6 hrs. of carbogen breathing to treatment with cyclophosphamide resulted in about 1 log increased tumor cell killing compared with the drug and carbogen breathing. Preparing the cyclophosphamide in the emulsion (12 ml/kg) and administering the combination i.v. resulted in an additional small increase in tumor cell killing compared with administering the drug and the emulsion as separate injections. Bone marrow is often a dose-limiting sensitive normal tissue in patients treated with cyclophosphamide, therefore it is very important to note that there was no significant increase in the killing of bone marrow CFU-GM upon addition of the perflubron emulsion and carbogen breathing to treatment with cyclophosphamide.

Administration of the perflubron emulsion followed by air breathing or carbogen breathing for 6 hrs. did not alter the growth of the FSaII fibrosarcoma. A single dose of melphalan (10 mg/kg) i.v. resulted in a tumor growth delay of about 3.6 days in the FSaII fibrosarcoma with carbogen breathing (6 hrs.) (**TABLE 3**). When melphalan administration was preceded by perflubron emulsion at doses of 4, 8 or 12 ml/kg i.v. and followed by carbogen breathing (6 hrs.) 3- to 4- fold increases in tumor growth delay resulted. The maximal tumor growth delay of about 11 days was obtained with 8 ml/kg along with melphalan and carbogen breathing (6 hrs.). When melphalan (10 mg/kg) was prepared in the emulsion (12 ml/kg), administered i.v. and followed by carbogen breathing (6 hrs.) a tumor growth delay of about 22.1 days resulted, representing a 7.5-fold increase over that obtained with the drug and carbogen breathing.

A single dose of cyclophosphamide (150 mg/kg i.v.) along with carbogen breathing (6 hrs.) produced a tumor growth delay of about 3.3 days (**TABLE 3**). The addition of the perflubron emulsion over a dosage range from 4 ml/kg to 12 ml/kg to this treatment resulted in about a 3.5-fold increase in tumor growth delay. There was no difference in the tumor growth delay obtained over the perflubron emulsion dosage range examined. When cyclophosphamide (150 mg/kg) was prepared in the perflubron emulsion (12 ml/kg) and administered as a single injection i.v. a tumor growth delay of about 13.5 days resulted, which was about a 5-fold increase over the tumor growth delay obtained with the drug and carbogen breathing.

BCNU (50 mg/kg) i.v. administered as a single dose along with carbogen breathing (6 hrs.) produced a tumor growth delay of

TABLE 2. Survival of FSaIIC tumor cells and bone marrow CFU-GM from animals treated *in vivo* with single doses of cyclophosphamide alone or in combination with the perflubron emulsion in doses of 12 ml/kg, 8 ml/kg or prepared in the emulsion (12 ml/kg) and followed by 6 hrs. of breathing carbogen. Data are the means of three experiments.

Treatment	Surviving Fraction	
	FSaIIC Tumor	Bone Marrow CFU-GM
Cyclophosphamide (mg/kg)		
0	1.00	1.00
100	0.14	0.35
300	0.0135	0.035
500	0.00035	0.014
Cyclophosphamide (mg/kg) ip, perflubron emulsion (12 ml/kg) iv		
0	1.00	1.00
100	0.078	0.28
300	0.0022	0.031
500	0.000055	0.0036
Cyclophosphamide (mg/kg) ip, perflubron emulsion (8 ml/kg) iv		
0	1.00	1.00
100	0.073	0.25
300	0.00022	0.037
500	<0.00001	0.0017
Cyclophosphamide prepared in perflubron emulsion (12 ml/kg) iv		
0	1.00	1.00
100	0.0094	0.16
300	0.00071	0.065
500	<0.00001	0.0027

TABLE 3. Growth delay of the FSaIIC fibrosarcoma produced by treatment with melphalan, cyclophosphamide or BCNU alone or in combination with various doses of the perflubron emulsion and carbogen breathing for 6 hrs.

Treatment Group	Tumor Growth Delay, Days			
	Perflubron Emulsion Dose, ml/kg			
	0	4	8	12
Melphalan (10 mg/kg)	3.6 ± 0.3	8.8 ± 0.6	11.3 ± 0.8	9.6 ± 0.7
Cyclophosphamide (150 mg/kg)	3.3 ± 0.3	8.7 ± 0.6	9.8 ± 0.7	8.7 ± 0.6
BCNU (550 mg/kg)	2.5 ± 0.3	4.1 ± 0.4	5.3 ± 0.7	5.5 ± 0.5
Prepared in perflubron emulsion				
Melphalan (10 mg/kg)				22.7 ± 2.4
Cyclophosphamide (150 mg/kg)				13.5 ± 1.7
BCNU (50 mg/kg)				8.5 ± 1.1

about 2.5 days in the FSaII fibrosarcoma (**TABLE 3**). The additional administration of the perflubron emulsion over a dosage range from 4 ml/kg to 12 ml/kg resulted in a 1.7- to 2.2-fold increase in tumor growth delay. Preparing the BCNU (50 mg/kg) in the emulsion (12 ml/kg) and administering the preparation as a single injection resulted in a tumor growth delay of about 8.5 days, which was a 3-4-fold increase in tumor growth delay compared with the results following treatment with the drug and carbogen breathing.

Tumor growth delay studies examining the effect of the administration of cyclophosphamide (3 x 150 mg/kg) by various routes along with the perflubron emulsion and carbogen breathing (6 hrs.) were performed in mice bearing the Lewis lung carcinoma (**TABLE 4**). When cyclophosphamide (150 mg/kg) was administered on alternate days for three doses i.p. a tumor growth delay of 21.5 days resulted. If the drug was administered i.v. a tumor growth delay of 22.3 days resulted which was not significantly different from 21.5 days. Adding administration of the perflubron emulsion (8 ml/kg, i.v.) followed by 6 hrs. of carbogen breathing to cyclophosphamide administered i.p. resulted in 29.5 days of tumor growth delay. When both agents were administered i.v. the tumor growth delay increased with increasing dose of the perflubron emulsion such that administration of the cyclophosphamide i.v. followed by the perflubron emulsion (8 ml/kg) i.v. and 6 hrs. of carbogen breathing resulted in a tumor growth delay of 36 days. The longest tumor growth delays were obtained when the cyclophosphamide was prepared in the perflubron emulsion and the mixture administered i.v. When the cyclophosphamide was administered in the perflubron emulsion (8 ml/kg) followed by carbogen breathing (6 hrs.) a tumor growth delay of 47 days was produced.

The Lewis lung carcinoma metastasizes avidly to the lungs from s.c. implanted tumor. Untreated animals bearing this tumor die from lung metastases between days 21 and 25 days post tumor implantation. On day 20 after tumor implantation untreated control animals had 16 lung metastases of which 63% (10 metastases) were vascularized (> 3 mm diameter) (**TABLE 5**). Administration of cyclophosphamide (150 mg/kg) on days 7, 9 and 11 post tumor implantation by the i.p. or i.v. route resulted in 13.5 lung metastases on day 20 of which 55% were large. The number of lung metastases present on day 20 after treatment of the animals with cyclophosphamide and the perflubron emulsion/carbogen breathing (6 hrs.) decreased with increasing dose of the perflubron emulsion and decreased in the same manner whether the drug and emulsion were administered separately or whether the drug was prepared in the emulsion. Thus, after administration of cyclophosphamide and the perflubron emulsion (8 ml/kg)/carbogen breathing (6 hrs.) Lewis

TABLE 4. Growth delay of the Lewis lung carcinoma produced by treatment with cyclophosphamide (150 mg/kg) on days 7, 9 and 11 post tumor implantation. The treatment regimens were: 1) cyclophosphamide administered i.p. with various doses of the perflubron emulsion administered i.v., 2) cyclophosphamide administered i.v. with various doses of the perflubron emulsion administered i.v. and 3) cyclophosphamide prepared in the perflubron emulsion administered as a single dose i.v. Carbogen breathing was maintained for 6 hrs. post each drug injection. The data are the means of three experiments (n=15).

Days	Tumor Growth Delay,					
	Perflubron Emulsion Dose, ml/kg:	0	2	4	6	8
Cyclophosphamide ip/Emulsion iv		21.5	—	—	—	29.5
Cyclophosphamide iv/Emulsion iv		22.3	23.9	27.4	32.2	36.0
Cyclophosphamide prepared in Emulsion iv		22.3	26.5	30.0	37.2	47.0

TABLE 5. Number of lung metastases on day 20 from s.c. Lewis lung tumors after treatment with cyclophosphamide and various doses of perflubron emulsion (PBE)/carbogen breathing.^a

Treatment Group	Mean Number of Lung Metastases (% Large) ^b	
	CTX + PBE	CTX in PBE
no treatment	16 (63)	
PBE dose, ml/kg	13.5 (55)	
0		
2	12.5 (40)	12.5 (45)
4	12 (50)	12 (40)
6	10 (40)	11 (30)
8	9 (30)	9.5 (25)

^aCyclophosphamide (CTX) (3 x 150 mg/kg) was administered i.v. on days 7, 9 and 11 either alone or prepared in the perflubron emulsion (PBE) or with the perflubron emulsion (PBE) administered i.v. as a separate injection. Carbogen breathing was maintained for 6 hrs. after CTX administration in the groups receiving drug treatment.

^bThe number of external lung metastases on day 20 post-tumor implant were counted manually and scored as > 3 mm in diameter. The data is shown as the means from 6-12 pairs of lungs. Parentheses indicated the percentage of the total number of metastases that were large.

lung carcinoma bearing animals had about 9 lung metastases of which 2-3 were large.

CONCLUSION

Although investigators have long sought biochemical characteristics unique to malignant cells that could be therapeutically exploitable, few, if any, have been found. Among the physiological characteristics of solid tumors that may protect some regions of the tumor from therapeutic regions of the tumor from therapeutic assault, hypoxia may be altered by relatively non-toxic means [3, 32-35]. With the greater availability of stable O₂-microelectrode systems suitable for use in the clinic, data supporting the notion that severe hypoxia frequently exists in human tumors at therapeutically significant levels is rapidly accumulating [5, 11-13]. Hypoxic cells limit the response of neoplasms to treatment with ionizing radiation as well as to many chemotherapeutic agents [6, 7, 17]. The concept of reoxygenation whereby the hypoxic subpopulation of a tumor becomes oxygenated following each dose of radiation forms an important foundation for the use of fractionated radiation therapy [36-38]. Ideally, upon lethal irradiation of the oxygenated cells in a tumor mass, the hypoxic cells would become oxygenated and be susceptible to the next radiation fraction. Several studies have shown that the hypoxic fraction in a tumor may remain relatively constant after radiation treatment indicating that reoxygenation occurs until the tumor reaches a certain equilibrium between oxygenated and hypoxic subpopulations [2-4, 6-8, 17-19]. The kinetics of reoxygenation, however, appear to vary widely in tumor model systems [39, 40]

In theory immediately after a dose of radiation sufficient to kill the oxygenated portion of a tumor that tumor should consist 100% of hypoxic cells. This issue has been addressed much more rarely in tumors after administration of chemotherapy. Recently, Dorie and Kallman [41] using the classic method of paired survival curve analysis for determining the hypoxic fraction of tumors that is irradiation of aerobic and artificially hypoxic tumors, found in the RIF-1 tumor that treatment with *cis*-diamminedichloroplatinum(II) (8 mg/kg) did not alter the hypoxic fraction of the tumor, that treatment with bleomycin (20 mg/kg) or mitomycin C (5 mg/kg) resulted in transient increase in the hypoxic fraction in the first hrs. post drug administration but that treatment with cyclophosphamide (100 mg/kg) resulted in an increase in the hypoxic fraction of the tumor that persisted over the 24 hr. period examined.

Although in cell culture 4-hydroperoxycyclophosphamide, an analog of cyclophosphamide with activity *in vitro*, does not show a selectivity for cytotoxicity toward normally oxygenated cells

compared with hypoxic cells, we found using Hoechst 33342 diffusion to separate cells near the vasculature from those distal from the vasculature that cyclophosphamide was much more cytotoxic toward cells near the vasculature which may be envisioned to be the oxygenated cells in the FSaII fibrosarcoma [17]. Both 24 hrs. and 48 hrs. after treatment with cyclophosphamide the rat mammary 13672 carcinoma remained markedly hypoxic compared with the pretreatment oxygenation level of the tumor. From the oxygen histograms of the tumor it appears that there is a diminution of the most oxygenated populations of the tumor. It may be concluded that reoxygenation is occurring very slowly in this tumor. Although carbogen breathing was able to increase the oxygenation of this tumor after treatment with cyclophosphamide, the combination of the perflubron emulsion with carbogen breathing was more effective in oxygenating the tumor. Only the combination of the perflubron emulsion and carbogen breathing was able to oxygenate albeit only to levels of 1-2 mmHg the most severely hypoxic regions of the tumor. It may be that this acute reoxygenation is therapeutically significant.

As observed previously with Fluosol-DA/carbon breathing in the FSaII fibrosarcoma [10, 20] and EMT-6 murine mammary carcinoma [10] administration of the perflubron emulsion/carbon breathing enhanced the therapeutic response produced by cyclophosphamide in the FSaII fibrosarcoma and the Lewis lung carcinoma.

The importance of reoxygenation in solid tumors has long been recognized in radiation biology [39, 40, 42, 43], however, the physiological status of the tumor is also important to the action of many chemotherapeutic agents [4, 7, 10, 17, 41]. A knowledge of the oxygenation status of a tumor mass may allow the selection and scheduling of anticancer drugs to optimize the activity of agents selectively cytotoxic toward oxygenated cells or those selectively cytotoxic toward hypoxic cells.

REFERENCES

1. B. A. Teicher, E. I. Frei. *Cancer Chemother. Pharmacol.*, 21:292-298, (1988).
2. E. I. Frei, B. A. Teicher, S. A. Holden, K. N. S. Cathcart, Y. Wang. *Cancer Res.*, 48:6417-6423, (1988).
3. E. I. Frei, B. A. Teicher, C. A. Cucchi, A. Rosowsky, J. L. Flatow, M. J. Kelley, P. Genereux. In: *Mechanisms of Drug Resistance in Neoplastic Cells*. Woolley PVI and Tew KD ed. New York: Academic Press 69-87, 1988.
4. A. C. Sartorelli. *Cancer Res.*, 48:775, (1988).
5. P. Vaupel, F. Kallinowski, P. Okunieff. *Cancer Res.*, 49:6449-6465, (1989).

6. K. A. Kennedy, B. A. Teicher, S. A. Rockwell, A. C. Sartorelli. *Biochem. Pharmacol.*, 29:18, (1980).
7. B. A. Teicher, J. S. Lazo, A. C. Sartorelli. *Cancer Res.*, 41:73-81, (1981).
8. R. K. Jain. *Cancer Res.*, 48:2641-2658, (1988).
9. E. M. Sevick, R. K. Jain. *Cancer Res.*, 49:3513-3519, (1989).
10. B. A. Teicher, T. S. Herman, J. Tanaka, J. P. Eder, S. A. Holden, G. Bubley, C. N. Coleman, E. Frei. *Cancer Res.*, 51:1086-1091, (1991).
11. P. Vaupel, K. Schlenger, C. Knoop, M. Höckel. *Cancer Res.*, 51:3316-3322, (1991).
12. P. Vaupel. In: *Drug Resistance in Oncology*. Teicher BA ed. New York, NY: Marcel-Dekker 53-85, 1993.
13. F. Kallinowski, R. Zander, M. Höckel, P. Vaupel. *Int. J. Radiat. Oncol. Biol. Phys.*, 19:953-961, (1990).
14. R. A. Gatenby, H. B. Kessler, J. S. Rosenblum, L. R. Coia, P. J. Moldofsky, W. H. Hartz, G. J. Broder. *Int. J. Radiat. Oncol. Biol. Phys.*, 14:831-838, (1988).
15. R. S. Bush, R. P. Hill. *Laryngoscope*, 85:1119-1133, (1975).
16. W. Duncan. *Br. Med. Bull.*, 29:33, (1973).
17. B. A. Teicher, S. A. Holden, A. Al-Achi, T. S. Herman. *Cancer Res.*, 50:3339-3344, (1990).
18. B. A. Teicher, N. L. McIntosh-Lowe, C. M. Rose. *Biomat., Art. Cells, Immobil. Biotech.*, 16:533-546, (1988).
19. B. A. Teicher, S. A. Holden. *Cancer Treat. Rep.*, 71:173-177, (1987).
20. B. A. Teicher, T. S. Herman, S. A. Holden, K. N. S. Cathcart. *Cancer Chemother. Pharmacol.*, 21:286-291, (1988).
21. B. A. Teicher, D. J. Waxman, S. A. Holden, Y. Wang, L. Clarke, E. Alvarez Sotomayor, S. M. Jones, E. Frei. *Cancer Res.*, 49:4996-5001, (1989).
22. B. A. Teicher, S. A. Holden, C. M. Rose. *Int. J. Cancer*, 38:285-288, (1986).
23. B. A. Teicher, T. S. Herman, C. M. Rose. *Int. J. Radiat. Oncol. Biol. Phys.*, 15:1187-1192, (1988).
24. B. A. Teicher, S. A. Holden, C. M. Rose. *Int. J. Cancer*, 36:585-589, (1985).
25. B. A. Teicher, S. A. Holden, J. L. Jacobs. *Cancer Res.*, 47:513-518, (1987b).
26. B. A. Teicher, J. M. Crawford, S. A. Holden, K. N. S. Cathcart. *Cancer Res.*, 47:5036-5041, (1987a).
27. A. R. Ahmed, S. M. Hombal. *J. Am. Acad. Dermatol.*, 11:1115-1126, (1984).

28. E. D. Thomas. *Semin. Oncol.*, 12 [Suppl 6]:15-20, (1985).
29. R. F. Borch, J. A. Millard. *J. Med. Chem.*, 30:427-431, (1987).
30. C. H. Kwon, K. Maddison, L. Locastro, R. F. Borch. *Cancer Res.*, 47:1505-1508, (1987).
31. O. M. Friedman, A. Myles, O. M. Colvin. In: *Advances in Cancer Chemotherapy*. Rosowsky A ed. New York: Dekker 159-164, 1979.
32. G. E. Adams. *Eur. J. Cancer*, 26:420-421, (1990).
33. J. R. Fowler, R. H. Thomlinson, A. E. Howes. *Eur. J. Cancer*, 6:207, (1970).
34. B. A. Teicher, C. M. Rose. *Cancer Res.*, 44:4285-4288, (1984).
35. B. A. Teicher, T. S. Herman, S. M. Jones. *Cancer Res.*, 49:2693-2697, (1989).
36. E. J. Hall. Philadelphia: Harper & Row, 1978: 235-243.
37. R. P. Hill. *Int. J. Radiat. Oncol. Biol. Phys.*, 12:1049-1054, (1986).
38. S. D. Young, R. P. Hill. *J. Natl. Cancer Inst.*, 82:371-380, (1990).
39. M. J. Dorie, R. F. Kallman. *Int. J. Radiat. Oncol. Biol. Phys.*, 12:1853-1859, (1986).
40. C. Grau, J. Overgaard. *Radiat. Res.*, 122:309-315, (1990).
41. M. J. Dorie, R. F. Kallman. *Int. J. Radiat. Oncol. Biol. Phys.*, 24:295-299, (1992).
42. A. E. Howes, A. Page, J. F. Fowler. *Brit. J. Radiol.*, 45:250-256, (1972).
43. R. F. Kallman. *Front. Radiat. Ther. Oncol.*, 22:30-49, (1988).

FULL-TIDAL LIQUID VENTILATION WITH PERFLUOROCARBON FOR
PREVENTION OF LUNG INJURY IN NEWBORN NON-HUMAN PRIMATES

J. Craig Jackson, Thomas A. Standaert, William E. Truog, and W. Alan Hodson
Department of Pediatrics
University of Washington
Seattle, Washington, USA

Abstract. Hyaline membrane disease (HMD), the most common life-threatening respiratory disorder of newborns, is associated with lung injury manifested by alveolar proteinaceous edema. The cause of the disease is thought to be elevated alveolar surface tension due to surfactant deficiency at birth. Treatment with exogenous surfactant may be unsuccessful due to problems in distribution of the surfactant, or inhibition of the surfactant by alveolar proteinaceous edema. Liquid ventilation with oxygen-saturated perfluorocarbon liquid has been proposed as a method to eliminate alveolar surface tension; little is known about the interfacial tension between perfluorocarbon liquids and the lung lining layer. Premature and term newborn monkeys were treated from birth with a pressure-limited, time-cycled liquid ventilator using oxygenated perfluorocarbon liquids (APF-145 and perflubron). Adequate gas exchange was achieved, and pilot experiments suggest long-term survival without adverse sequelae. Although many questions remain, liquid ventilation is a promising tool for the prevention and treatment of lung injury in newborns.

INTRODUCTION

Clinical description of HMD. Hyaline membrane disease (HMD), also known as respiratory distress syndrome, occurs in nearly 100,000 infants in the U.S. each year causing the death of several thousand annually. The typical course of HMD is characterized by progressive respiratory failure over the first few hours of life, with signs of increased work of breathing and cyanosis; supplemental oxygen is required and

often mechanical ventilation is needed for respiratory acidosis. With supportive care, the disease reaches its peak severity in about 2 days, and then, in most infants, resolves over the next few days. About 25% of infants with severe HMD fail to recover normally, and their lung injury at birth evolves into a chronic pulmonary insufficiency known as bronchopulmonary dysplasia (BPD), manifested by chronic oxygen dependency (for several weeks or months) and often prolonged need for mechanical ventilation, bronchodilators, and corticosteroids.

Pathogenesis of HMD. Although not completely understood, lung immaturity clearly is important in the cause and sequelae of HMD. Central to the pathogenesis of HMD is a deficiency of alveolar surfactant combined with structural immaturity; elevated surface tension leads to unstable alveoli, reduced functional residual capacity, and increased work of breathing. By poorly understood mechanisms, there is leak of fluid and protein into airspaces after onset of air-breathing. It has been speculated that this lung injury is caused by the repetitive opening and recollapse of immature alveolar saccules and ducts (discussed in more detail below). Pesenti *et al* [1] prevented lung injury in premature lambs by apneic oxygenation (with extracorporeal CO₂ removal) and avoidance of any cyclic lung inflation. High frequency ventilation was developed with the intention of maintaining alveolar volume but avoiding large pressure-volume excursions that might damage the lungs; if used from birth in premature non-human primates, this mode of ventilation improves inflation pattern and reduces lung injury [2,3].

It remains unproven whether high interfacial tension with irregular lung inflation pattern and the resultant excess local stresses are central in the pathogenesis of HMD, but there are few other explanations for the observed pancellular injury in this disease. Because the injury is observed within the first hour of life [4], lung ischemia, infection, and oxygen radical damage do not appear to be likely candidates as initial causative agents. Although it would be ideal to administer exogenous surfactant uniformly to lung alveoli prior to the occurrence of lung damage, efforts to do so are hampered by logistical difficulties in delivering surfactant with the first breath, and with problems in surfactant distribution during intratracheal injection and positive pressure gas breathing. Although clinical trials have demonstrated improvements in survival and severity of HMD when exogenous surfactant is given within the first few minutes of life, followed

by repeated doses over the next 48 hours, the incidence of bronchopulmonary dysplasia remains high [5].

Role of inflation pattern in lung injury. Enhorning and Robertson [6,7] proposed that the resistance of alveoli to inflation leads to over-distention of distal bronchioles during peak inflation, and that this over-distention damages the bronchiolar epithelium. Nilsson *et al* [8] reported that surfactant-treated premature rabbits, even if ventilated with high peak pressures, did not develop lung injury; they concluded that it is the abnormal expansion pattern in the surfactant-deficient animal that leads to lung injury. These authors proposed that over-distention of airways and irregular aeration of the alveolar compartment produce shear forces in the airway mucosa, leading to disruption of the epithelium and to formation of hyaline membranes. Scanning electron microscopy was used to demonstrate the uniformity of inflation in animals treated with surfactant, and of the irregular pattern of alveolar aeration in those not treated [9]. This heterogenous pattern of lung inflation is associated with vascular-to-alveolar leak of proteinaceous fluid within as little as 5 minutes of gas ventilation [4]. With tearing of the supportive structures, there might be coalescence of adjacent alveoli and, eventually, pulmonary emphysema. Other studies have noted that the presence of proteinaceous fluid in alveoli is a stimulus to lung fibrosis [10,11]. Clinically, the syndrome of emphysema and fibrosis that evolves from severe HMD in infants is termed BPD.

Physical properties. Although perfluorocarbon liquids have higher viscosity and density than water, the solubility of O₂ and CO₂ in PFC is much greater:

TABLE. Physical properties of PFC liquids at 37° C.

	Kinematic viscosity, centi- stokes	Density, g/ml	Vapor Pres., torr	ml O ₂ per 100 ml fluid at 1 atm	ml CO ₂ per 100 ml fluid at 1 atm	
FC-72	0.36	1.63	400	65	228	[12]
FC-77	0.66	1.75	75	56	198	[13]
FC-80	1.43	1.76	?	48	160	[14]
Rimar-101	1.17	1.76	?	?	?	
APF-145	1.44	1.91	?	?	?	
Perflubron	1.70	1.93	14	50	210	[15]
Water	0.69	1.00	47	3	55	
Air	0.17	0.0011	--	21	--	

The surface tensions of several PFC liquids against air have been reported to be between 10 and 16 dynes/cm, among the lowest ever recorded for liquids [14]. However, an important characteristic of the fluids for liquid ventilation is their interfacial tension with lung liquid. Kylstra and Schoenfisch [16] reported an interfacial tension between the PFC liquid FC-80 and saline to be 58 dynes/cm. However, Schwieler and Robertson [17] estimated the interfacial tension between PFC and lung liquid to be only 7 dynes/cm.

Schürch *et al* [18] took advantage of the stability of interfacial tension between PFC and lung liquid to measure intra-alveolar interfacial tension in excised lungs; they first measured the diameter of a lens-shaped drop of fluorocarbon liquid FC-43 placed in a large bubble which was lined with a monolayer of dipalmitoyl phosphatidylcholine, and calibrated this diameter against the independently-measured surface tension of the bubble. They used drops of FC-43 layered on a surfactant film in a surface balance to prove that the surfactant film at the PFC-subphase interface changes its interfacial tension according to the change in the film surface tension outside the droplet; they demonstrated that the surfactant film is neither displaced nor disrupted by the perfluorocarbon droplet, and that the surfactant film extends continuously from the air-saline to the PFC-saline interface. These observations suggest that the physical properties of PFC should not disrupt alveolar surfactant during liquid ventilation, and a "lens" of PFC left partially covering an alveolar septum after liquid ventilation should not, at least theoretically, affect alveolar surface tension.

Animal studies with liquid ventilation. Clark and Gollan [19] were the first to report survival of mammals breathing normobarically-oxygenated perfluorocarbon liquid. Subsequent studies indicated that mammals can tolerate liquid ventilation with PFC liquids and survive a return to gas breathing [20-22]. Several groups of investigators have successfully ventilated premature and term newborn animals with PFC liquids [17, 23-26]. The apparent superiority of liquid ventilation to gas ventilation in premature animals was assumed to be the result of abolishing the air-liquid interface and its very high surface tension (eg > 25 dynes/cm). Residual PFC after liquid ventilation was thought to be an advantage because of its relatively low surface tension (15 dynes/cm). This was also thought to explain the deterioration in pulmonary function of adult animals during gas breathing after PFC ventilation [21,22], since the very low

minimal surface tension in the normal adult lung (eg, 2 dynes/cm) may be raised by residual PFC.

Histologic studies after PFC ventilation in premature animals are few. Schwieler and Robertson [17] noted that immature rabbits ventilated from birth with liquid had less injury to the bronchiolar epithelium and no hyaline membranes, compared to those ventilated with gas. A study published in abstract form [27] suggests that there is no disruption of the alveolar lining layer after liquid breathing. In a study just published, Wolfson *et al* [28] reported less histologic evidence of barotrauma in very premature lambs that had undergone 3 hours of liquid ventilation, compared to gas ventilated controls; whereas the gas-ventilated lungs demonstrated proteinaceous alveolar exudate, the liquid-ventilated lungs were uniformly expanded and free of luminal debris.

Work in lambs by Shaffer and associates over the past several years has demonstrated that liquid ventilation is an excellent tool to study extrauterine physiology in extremely premature lambs, delivered prior to viability with gas ventilation [29,30]. Problems with increased pulmonary vascular resistance [31], alterations in cardiac output, and the development of metabolic acidosis [13] were overcome by careful intravenous fluid loading and limitation of peak alveolar pressures. Studies in liquid ventilation have required high proximal airway pressures; experiments in newborn lambs demonstrated that in one protocol the use of peak airway pressure equal to 31.5 torr was associated with peak alveolar pressure of only 18.6 torr due to a large flow resistive pressure drop of 13 torr along the bronchial tree [12]. This study indicates the importance of measuring peak alveolar pressure, and not proximal airway pressure alone.

Liquid ventilation in newborn non-human primates. Previously in our laboratories, we have studied the impact of conventional and high frequency ventilation on the development of lung injury in prematurely-delivered monkeys [3,32]. We are now investigating whether liquid ventilation, used from birth, prevents lung injury compared to gas ventilation. We are also studying liquid ventilation as a treatment for established HMD. Long-term survival studies are also underway to determine the clinical safety of this technique. The methods and results of these studies in progress are reported below.

MATERIALS AND METHODS

Liquid ventilation. Medical grade perfluorocarbon liquids were oxygenated with equipment commonly used for extracorporeal membrane oxygenation. A roller pump (Sarnes, Ann Arbor) was used to force the perfluorocarbon liquid through a membrane oxygenator (0800, SciMed, Minneapolis) and a counter-current heat-exchanger (ECMOtherm, SciMed, Minneapolis) warmed to 42° C. by a water heater (Micro-Temp Pump, Seabrook, Cincinnati) at 100 mL/minute. The oxygenator was connected to 100% oxygen at 2 L/min; the outflow was directed through cold (6-8° C.) copper tubing to condense vaporized perfluorocarbon. The oxygenated perfluorocarbon liquid ($PO_2 > 600$ torr) was pumped to the inspiratory reservoir, the height of which was adjustable. A microswitch was used to open a solenoid pinch valve (Ledex, Vandalia, OH) on the inspiratory tubing and simultaneously close another solenoid pinch valve on the expiratory tubing; the microswitch timer (Instrument Development Laboratory, CDMRC, UW) was used to open and close the valves at an adjustable breathing rate, and at an adjustable ratio of inspiratory to expiratory time. The animal's weight was monitored continuously with an electronic scale (E1200S, Sartorius, Bohemia, NY) to determine tidal volume. The expiratory tubing was directed into the expiratory reservoir from which the roller pump drew fluid. An overflow line connected the inspiratory and expiratory reservoirs in order to maintain a fixed inspiratory pressure, while allowing flow of fluid through the membrane oxygenator in excess of the volume needed for ventilation.

The proximal endotracheal tube pressure was measured continuously on a chart recorder; end-inspiratory and end-expiratory alveolar pressures were measured after any change in ventilator settings and at least hourly by clamping briefly both inflow and outflow lines from the endotracheal tube at appropriate points in the ventilatory cycle and allowing equilibration of alveolar and endotracheal pressures. Target end-inspiratory and end-expiratory alveolar pressures were 10 and 1 cm H₂O, respectively.

The initial ventilator rate was set at 8 breaths per minute, with inspiratory-to-expiratory ratio of 1:1; the initial inflation pressure was 30 cm H₂O (resulting in peak alveolar pressure of 10-15 cm H₂O). These settings were varied as necessary to keep P_aCO_2 between 40 and 50 torr, and to keep P_aO_2 greater than 50 torr.

Delivery and care of primates. Monkeys of the species *Macaca nemestrina* were delivered by hysterotomy after timed conception (± 1 day) at 133-135 days'

gestation, or just before term gestation (168 days). During the first few seconds after delivery, the infants were quickly dried, weighed, and positioned slightly head down under a radiant warmer. A cuffed endotracheal tube (2.0 mm inner diameter) was immediately inserted and then connected to the liquid ventilation apparatus. No manual breaths with gas were given. During the first minute of life, 20 mg/kg of succinyl choline was administered via the umbilical vein to prevent spontaneous respiratory effort. An umbilical artery catheter was then inserted into the lower abdominal aorta and 0.1 mg/kg of pancuronium bromide was administered for more sustained muscular paralysis. A rectal temperature probe was inserted and the animal was transported to the laboratory while being heated and ventilated on a cart; electrical power was supplied by a portable battery-powered DC-AC inverter.

Upon arrival in the laboratory, the animals were provided with a radiant heat source servo-controlled to a skin thermistor in order to keep the rectal temperature between 36.5° and 37.5° C. Both the rectal and airway fluid temperature were continuously monitored. Arterial blood gas tensions and pH were measured at least hourly in blood samples withdrawn from the umbilical artery catheter; all blood losses were replaced with maternal whole blood. Morphine sulphate was administered for sedation via the umbilical artery catheter at 24 µg/kg/h with 10% dextrose in water at 150 ml/kg/day by syringe infusion pump. Blood pressure, heart rate, and airway pressure were continuously monitored with audible alarms for high and low values. To maintain muscular paralysis, pancuronium bromide, 0.1 mg/kg, was given every 2 hours. Anteroposterior and lateral chest radiographs were obtained by a portable x-ray unit at 5 hours of age and as clinically indicated at peak inspiratory as well as at end expiratory pressure to determine state of lung inflation (PFC liquids are radiodense).

RESULTS

Prevention of lung injury. Three premature *M. nemestrina* (134 days' gestation) were ventilated with PFC (APF-145) for the first six hours of life prior to sacrifice for histology. Excellent gas exchange (P_aO_2 100-300 torr; P_aCO_2 35-45 torr) was achieved during the six hour experiments with peak alveolar pressures of 20 cm H_2O , tidal volume of 18 ml/kg, and ventilator rate of 8 breaths per minute. Postmortem studies and additional animal experiments are underway to determine whether there was a reduction in lung injury.

Subsequently two premature monkeys have been ventilated with PFC (APF-145) for the first 3 hours of life, followed by 3 hours of gas ventilation. Gas exchange was satisfactory during and after liquid ventilation. Postmortem studies are in progress.

Treatment of lung injury. One premature monkey was first ventilated with gas for 3 hours; clinically, radiographically, and by measurements of lung volumes, it had severe HMD. After starting liquid ventilation with PFC (APF-145) at 3 hours of age, both the peak alveolar pressures and the minute ventilation were reduced by half. The arterial PCO_2 remained at 40 torr, and the arterial PO_2 increased from 91 to 157 torr. Liquid ventilation was well tolerated during the next 3 hours.

Long-term survival. Two near-term *M. nemestrina* were treated from birth with liquid ventilation (using perflubron [LiquiVent, Alliance Pharmaceutical Corp.]) for 3 hours. Gas exchange was excellent in the first animal (arterial PCO_2 44 and PO_2 244 at the end of the 3 hours) and adequate in the second (arterial PCO_2 55 and PO_2 62 at the end of 3 hours); both had arterial PO_2 values in excess of 250 torr after returning to low-pressure conventional mechanical ventilation. Serial radiographs were used to follow the evaporation of most of the PFC liquid over the next several hours; both were extubated by 8 hours of age, and required no supplemental oxygen after one and three days, respectively. Sequential neurodevelopmental and pulmonary testing through 11 months of age have shown no persistent abnormalities. One of the animals was electively sacrificed at 11 months of age, after measurement of lung volumes by nitrogen washout; both functional residual capacity and total lung capacity were normal. Chest radiographs showed persistence of scattered densities, compatible with interstitial radiodense PFC. At postmortem examination, there were no abnormalities of lung structure or histology; evidence of acute tracheitis was ascribed to the procedures used for lung volume measurements during the hours prior to sacrifice. There were no gross or microscopic abnormalities of other organs. Tissue levels of PFC are pending.

DISCUSSION

These preliminary studies in non-human primates provide additional evidence for the feasibility of full-tidal liquid ventilation in newborn infants at risk for, or with established, hyaline membrane disease. If the completed studies suggest reduced lung injury compared to conventional clinical techniques, and if additional animal studies indicate relative safety, liquid ventilation will warrant clinical investigation.

There are many unanswered questions regarding liquid ventilation in newborns. In order to limit lung injury associated with gas ventilation, it should ideally be started with the first breath. Will it be feasible to begin liquid ventilation in the delivery room, as was done in the current study? Given that lung injury can occur within minutes after initiation of gas ventilation [4], it is likely that early use will be more beneficial than late use in improving survival and reducing the incidence of acute and chronic lung injury.

Should the liquid ventilator be pressure-limited, as used in the current study, or volume-limited? The former method is technically more simple, but may not be as effective because of the time delay at the beginning of inspiration due to fluid inertia. Because of the resistive pressure gradient along the endotracheal tube and bronchial tree, estimation of alveolar pressure will be problematic. The stop-flow technique for intermittent measurement of alveolar pressure used in these experiments is one possible technique that could be automated in a clinical liquid ventilator.

How long will liquid ventilation be required? In the larger premature infants, only a day or two may be needed, assuming that mechanisms for endogenous surfactant secretion rapidly mature during the repetitive lung inflation of liquid ventilation. The retention of residual PFC liquid after initiating gas ventilation may provide a uniform lowering of surface tension, further enhancing the ability of the immature lung with marginal alveolar surfactant to make the transition to air-breathing.

Perfluorocarbon-associated gas exchange (PAGE), also known as partial liquid ventilation, has been proposed as an alternative mode of liquid ventilation by Fuhrman *et al* [33]. In this method, a dose of PFC equivalent to the normal functional residual capacity (about 30 mL/kg) is given via the trachea; gas ventilation is then resumed. This method of ventilation has the practical advantage of using existing gas ventilators and is technically much simpler. But will it lead to reduced lung injury, compared to full-tidal liquid ventilation? Will the repetitive movement of the gas-liquid interface into, and out of, alveoli during this method damage the fragile immature lung? Is the effective surface tension of the alveolus the sum of the interfacial tension between lung liquid and PFC, and that between PFC and air? Is the alveolus lined with PFC throughout the ventilatory cycle, or does the PFC "puddle" in the alveoli at peak inflation? Does it change with the state of lung inflation? These questions are important not only for PAGE (partial liquid ventilation), but for the transition from full-tidal liquid ventilation to gas ventilation when there is residual PFC.

Although many questions remain, liquid ventilation is a promising tool for the prevention of lung injury in newborns.

ACKNOWLEDGEMENTS

The authors gratefully acknowledge the technical support of Dr. Mike Sekins (Alliance Pharmaceutical Corp.) and Dr. Thomas Shaffer (Temple University). Funding support was provided in part by U.S. Public Health Service Grant RR-00166 to the Regional Primate Research Center at the University of Washington and by Grant HL-39157.

REFERENCES

1. A Pesenti, T Kolobov, DK Buckhold, JE Pierce, H Huang, V Chen: Prevention of hyaline membrane disease in premature lambs by apneic oxygenation and extracorporeal carbon dioxide removal. *Intensive Care Med* 8:11-17 (1982).
2. KS Meredith, RA de Lemos, JJ Coalson, *et al*: Role of lung injury in the pathogenesis of hyaline membrane disease in premature baboons. *J Appl Physiol* 66:2150-8 (1989).
3. JC Jackson, WE Truog, TA Standaert, SE Juul, JH Murphy, EY Chi, AP MacKenzie, and WA Hodson: Effect of high frequency ventilation on the development of alveolar edema in premature monkeys at risk for hyaline membrane disease. *Am Rev Respir Dis* 143:865-871 (1991).
4. B Robertson, G Grossmann, A Jobe, M Ikegami, A Pettenazzo, S Seidner: Vascular to alveolar leak of iron dextran (120 kD) in the immature ventilated rabbit lung. *Pediatr Res* 25:130-5 (1989).
5. RE Hoekstra, JC Jackson, TF Myers, *et al*: Improved neonatal survival following multiple doses of bovine surfactant in very premature neonates at risk for respiratory distress syndrome. *Pediatrics* 88:10-18 (1991).
6. G Enhorning, B Robertson: Lung expansion in the premature rabbit fetus after tracheal deposition of surfactant. *Pediatrics* 50:58-66 (1972).
7. B Robertson: Pathology and pathophysiology of neonatal surfactant deficiency. In: Robertson B, Van Golde LMG, Batenburg JJ, eds. *Pulmonary surfactant*. Amsterdam: Elsevier, pp. 391-3 (1984).
8. R Nilsson, G Grossmann, B Robertson: Pathogenesis of neonatal lung lesions induced by artificial ventilation: evidence against the role of barotrauma. *Respiration* 40:218-25 (1980).
9. G Grossmann, R Nilsson, B Robertson: Scanning electron microscopy of epithelial lesions induced by artificial ventilation of the immature neonatal lung; the prophylactic effect of surfactant replacement. *Eur J Pediatr* 145:361-7 (1986).

10. LF Brown, AM Dvorak, HF Dvorak: Leaky vessels, fibrin deposition, and fibrosis: a sequence of events common to solid tumors and to many other types of disease. *Am Rev Respir Dis* 140:1104-7 (1989).
11. C Kuhn, J Boldt, TE King, E Crouch, T Vartio, JA McDonald: An immunohistochemical study of architectural remodeling and connective tissue synthesis in pulmonary fibrosis. *Am Rev Respir Dis* 140:1693-1703 (1989).
12. SE Curtis, BP Fuhrman, DF Howland: Airway and alveolar pressures during perfluorocarbon breathing in infant lambs. *J Appl Physiol* 68:2322-8 (1990).
13. SE Curtis, BP Fuhrman, DF Howland, M DeFrancis, EK Motoyama: Cardiac output during liquid (perfluorocarbon) breathing in newborn piglets. *Crit Care Med* 19:225-230 (1991).
14. JW Sargent, RJ Seffl: Properties of perfluorinated liquids. *Fed Proceed* 29:1699-1703 (1970).
15. Alliance Pharmaceutical Corp., San Diego CA. Data sheet on neat Perfluorooctylbromide (perflubron) (1991).
16. JA Kylstra, WH Schoenfisch: Alveolar surface tension in fluorocarbon-filled lungs. *J Appl Physiol* 33:32-35 (1972).
17. GH Schwieler, B Robertson: Liquid ventilation in immature newborn rabbits. *Biol Neonate* 29:343-353 (1976).
18. S Schürch, H Bachofen, ER Weibel: Alveolar surface tensions in excised rabbit lungs: effect of temperature. *Respir Physiol* 62:31-45 (1985).
19. LC Clark, F Gollan: Survival of mammals breathing organic liquid equilibrated with oxygen at atmospheric pressure. *Science* 132:1755-6 (1966).
20. JH Modell, EJ Newby, BC Ruiz: Long term survival of dogs after breathing oxygenated fluorocarbon liquid. *Fed Proc* 29:1731-36 (1970).
21. S Saga, JH Modell, HW Calderwood, AJ Lucas, MK Tham, EW Swenson: Pulmonary function after ventilation with fluorocarbon liquid P12-F (Caroxin-F). *J Appl Physiol* 34:160-4 (1973).
22. TH Shaffer, GD Moskowitz: Demand-controlled liquid ventilation of the lungs. *J Appl Physiol* 36:208-215 (1974).
23. F Gollan, J McDermott, AC Johnson, R Namon: Compliance and diffusion during respiration with fluorocarbon liquid. *Fed Proc* 29:1725-30 (1970).
24. A Walker, M Petrovic, J Ponitch, GC Ritchie: Redistribution of cardiac output during liquid breathing in the newborn rabbit. *Aust J Exp Biol Med Sci* 50:467-476 (1972).

25. R Rufer, HL Spitzer: Liquid ventilation in the respiratory distress syndrome. *Chest* 66:29S-30S (1974).
26. TH Shaffer, D Rubenstein, GD Moskowitz, M Delivoria-Papadopoulos: Gaseous exchange and acid-base balance in premature lambs during liquid ventilation since birth. *Pediatr Res* 10:227-231 (1976).
27. D Forman, VK Bhutani, SR Hilfer, TH Shaffer: A fine structure study of the liquid-ventilated newborn rabbit (abst). *Fed Proc* 43:647 (1984).
28. MR Wolfson, JS Greenspan, KS Deoras, SD Rubenstein, TH Shaffer: Comparison of gas and liquid ventilation: clinical, physiological, and histological correlates. *J Appl Physiol* 72:1024-31 (1992).
29. TH Shaffer, N Tran, VK Bhutani, EM Sivieri: Cardiopulmonary function in very preterm lambs during liquid ventilation. *Pediatr Res* 17:680-4 (1983).
30. MR Wolfson, N Tran, VK Bhutani, TH Shaffer: A new experimental approach for the study of cardiopulmonary physiology during early development. *J Appl Physiol* 65:1436-43 (1988).
31. CA Lowe, TH Shaffer: Pulmonary vascular resistance in the fluorocarbon-filled lung. *J Appl Physiol* 60:154-9 (1986).
32. JC Jackson, AP MacKenzie, EY Chi, TA Standaert, WE Truog, WA Hodson: Mechanisms for loss of total lung capacity in monkeys with hyaline membrane disease. *Am Rev Respir Dis* 142:413-9 (1990).
33. BP Fuhrman, PR Paczan, M DeFrancis: Perfluorocarbon-associated gas exchange. *Crit Care Med* 19:712-722 (1991).

PERFLUOROCARBON ASSOCIATED GAS EXCHANGE (PAGE):
GAS VENTILATION OF THE PERFLUOROCARBON FILLED LUNG

BP Fuhrman, LJ Hernan, BA Holm, CL Leach, MC Papo, DM Steinhorn.
State University of New York at Buffalo and Children's Hospital of
Buffalo, New York. Pediatric Critical Care, Children's Hospital,
219 Bryant Street, Buffalo, N. Y. 14222

ABSTRACT

Background: Throughout most of the second half of this century, progress in respiratory life support was dominated by modernization of the mechanical ventilator. We have now entered an era in which the fundamental physiology of lung function can be manipulated to improve lung performance in hope of reducing morbidity and mortality and thereby decreasing the cost of intensive care.

Main Findings: Despite its almost alien technology, perfluorocarbon tidal liquid breathing is an effective means to support respiration in normal and surfactant deficient lungs. A second, technique, perfluorocarbon associated gas exchange (PAGE), has recently been shown effective in normal lungs and in several animal models of lung disease. Both techniques appear to improve pulmonary function when pulmonary surface tension is elevated.

Conclusions: PAGE improves lung function and poses opportunities to reduce pulmonary morbidity and diminish the cost of intensive care.

The availability of bottled oxygen, and the development of positive pressure breathing devices revolutionized pulmonary medicine and ushered in the modern era of intensive care.

Throughout most of the second half of this century, progress in respiratory life support was dominated by modernization of the mechanical ventilator. The introduction of positive end-expiratory pressure (PEEP) was followed by a dramatic diversification of the means of breathing within reach of modern technology.

It has recently become almost commonplace in this country to support neonates (having severe but reversible lung disease) using extracorporeal membrane oxygenation (ECMO). ECMO uses extracorporeal circulation to support gas exchange while reducing inspiratory oxygen tension and minimizing pulmonary barotrauma.

Advances in critical care will no doubt entail further refinement of these technologies, and current shortcomings may soon be overcome. Yet these shortcomings remain substantial in 1993: (1) Ventilators still cause barotrauma because they tend to force gas into non-receptive lungs. (2) High oxygen concentration gas mixtures still cause pulmonary oxygen toxicity. (3) ECMO and its variations still require heparinization and the sacrifice of large vessels, often the right carotid artery. (4) Our technology has become increasingly expensive, outstripping the capacity of society to afford it and widening the health care gap between rich and poor.

We have now entered an era in which the fundamental physiology of lung function can be manipulated to improve lung performance. Surfactants can be instilled to improve ventilation in premature infants, and tantalizing evidence suggests that we may soon be able to modify ventilation/perfusion matching using nitric oxide to dilate pulmonary vessels of well ventilated alveolar capillary units.

Advances like these could offer the potential to reduce morbidity, thereby cutting the cost of intensive care, while improving outcome.

Liquid breathing is another innovation that improves lung function, and offers promise as a means to reduce morbidity, mortality and the cost of intensive care.

RATIONALE FOR LIQUID BREATHING

The alveolus is lined by a liquid gel. Distension of the alveolus stretches this liquid surface. This distension is opposed by surface tension of the gel. Mammals have evolved a means to minimize this surface tension, the surfactant system.

The synthesis of surfactant is often transiently deficient in the premature infant. In surfactant deficiency, alveoli are noncompliant and unstable, tending to collapse spontaneously. Moreover, compliance varies from alveolus to alveolus. The pressure required to maintain expansion of noncompliant alveoli may be sufficient to over-distend or rupture compliant alveoli.

In the adult respiratory distress syndrome (ARDS), blood protein leaks into the alveolar space. This protein interferes with surfactant function, causing alveolar instability.

Surface tension forces within the alveolus are a manifestation of the air/fluid interfaces that line alveolar septae. It has long been known that these forces can be markedly attenuated by filling the alveolus with liquid rather than gas, because this eliminates air/fluid interfaces. Tidal liquid ventilation takes advantage of this principle.

TIDAL LIQUID BREATHING

In tidal liquid ventilation, a liquid medium is used to transport dissolved oxygen and carbon dioxide. Inhaled liquid brings dissolved oxygen to the lungs and exhaled liquid carries off carbon dioxide.

Mammals breathe in and out through a system of branching airways. Narrow bronchial tubes offer high resistance to flow, and are not well suited to the flow of high viscosity liquid.

Nonetheless, in the 1960's, Kylstra[1] showed that dogs could be ventilated using hyperbarically oxygenated saline. Unfortunately, saline has a very low solubility for oxygen; it is rather viscous; and it is miscible with surfactant, washing it out of the lungs.

Fortunately, there is a class of solvent with properties favorable for liquid breathing. Perfluorocarbons have high gas

solubility, moderate viscosity, and low surface tension. They are biologically inert and are not miscible with surfactant.

Perfluorocarbon tidal liquid breathing has been studied in both normal and abnormal lungs. In general, liquid is introduced into the lungs in tidal breaths. Exhaled liquid is processed, outside the body, to add oxygen, purge it of carbon dioxide, and regulate its temperature.

Despite this almost alien technology, perfluorocarbon tidal liquid breathing is an effective means to support respiration in the normal lung. Tidal liquid breathing can be accomplished at alveolar pressures well within the range of normal[2], without acidosis or impaired cardiac output[3]. Oxygenation and carbon dioxide removal are adequate, and normal oxygen consumption is preserved. Moreover, Shaffer et al have shown that tidal liquid breathing can be used to support premature lambs with surfactant deficiency even before alveolar architecture matures[4].

The past two decades have witnessed an increase in the sophistication of hardware for tidal liquid breathing. Only recently have there been efforts to refine and simplify this technology. Even in its simplest form, tidal liquid breathing is so different from conventional CPPB as to appear daunting. Moreover, the relatively high viscosity of the liquid limits the number of breaths per minute that can be delivered, because the time constant of the mammalian lung for movement of liquid along airways is strikingly longer than it is for gas.

PERFLUOROCARBON ASSOCIATED GAS EXCHANGE (PAGE)

Perfluorocarbon associated gas exchange (PAGE)[5] is an alternative means to apply these liquids to lung disease. Also termed partial liquid ventilation (PLV), PAGE is gas ventilation of the liquid filled lung.

In PAGE, the lung is filled with perfluorocarbon, a volume essentially equivalent to the pulmonary functional residual capacity, about 30 ml/kg in the normal adult. This volume of liquid is left in place, within the lung, and gas ventilation is resumed using a conventional gas ventilator. In inspiration, oxygen gas

is pushed down the airway into the liquid filled alveoli where it forms air pockets or bubbles. By a process akin to bubble oxygenation, as practiced during extracorporeal support for cardiac bypass, oxygen and carbon dioxide are exchanged across the surface of each bubble. In this manner, the alveolar perfluorocarbon reservoir is oxygenated and purged of carbon dioxide. In exhalation, gas appears to be expelled from the lung largely by the intrinsic elastic recoil of the bubbles. Perfluorocarbon wells back up into the airways in expiration but only after most of the gas has escaped, because the liquid has greater viscosity, density and inertia than the gas. Breaths of oxygen gas are delivered at a frequency appropriate for size and age of the mammal, as respiratory rate is not limited by the long time constant that would be imposed by the movement of liquid. It is predominantly gas that is moved during PAGE. In fact, the airways can be kept virtually free of perfluorocarbon throughout the respiratory cycle by the application of positive end-expiratory pressure (PEEP).

Studies of PAGE in normal piglets suggest that, in small animals without lung disease, this technique of gas exchange is almost as efficient as conventional gas breathing by CPPB. Oxygenation and carbon dioxide clearance were well preserved during PAGE. Moreover, lung compliance and airway resistance were affected very little by the presence of 30 ml/kg of liquid within the lung, so peak and mean airway pressures are not elevated during PAGE. In normal piglets, expiratory air flow was almost as rapid during PAGE as during CPPB, and the respiratory time constant was not substantially prolonged compared to gas breathing without perfluorocarbon (CPPB). It is predominantly gas, not air that moves through the bronchi during PAGE. It is, therefore, not necessary to reduce the respiratory frequency to institute PAGE in normals. Early investigations show that, using the high purity perfluorocarbon perflubron (LiquiVenttm, Alliance Pharmaceutical Corp., San Diego) PAGE can be accomplished for prolonged periods without deterioration in lung function[6]. Moreover, evaporation can almost completely clear the lungs of perflubron within 24 hours, and post evaporation histology is remarkably normal.

Leach et al have shown that PAGE is effective in the surfactant deficient premature lamb[7]. Not only did PAGE improve oxygenation and carbon dioxide elimination in that model, it improved lung compliance as well. A normal tidal volume was used to ventilate surfactant deficient lambs at airway pressures substantially lower than those required to deliver small breaths before perfluorocarbon (perflubron) instillation. The respiratory time constant, which is dramatically diminished in the stiff, surfactant deficient lung, lengthened toward normal, necessitating appropriate changes in ventilation rate.

Papo et al have shown that PAGE, using perflubron, improves gas exchange after intravenous oleic acid lung injury in piglets, an animal model of ARDS[8]. Even more dramatic is the apparent preservation of lung function when PAGE is instituted before oleic acid infusion. Histology was, again, dramatically improved by PAGE rescue of oleic acid treated piglets using perflubron.

Thompson et al have shown efficacy of PAGE, using perflubron, in a piglet model of meconium aspiration syndrome[9]. Not only did PAGE with perflubron improve gas exchange, it increased survival from 1/8 controls to 8/8 PAGE treated animals.

Nesti et al have shown that gastric aspiration ARDS is also effectively treated by PAGE with perflubron in a piglet model. Both survival and gas exchange were improved[10]. Gastric aspiration is thought to be the trigger of ARDS in about one third of the 100,000 to 150,000 ARDS cases cared for in the US each year.

CONCLUSIONS

PAGE is well tolerated in normal piglets, and appears to improve lung function in several models of lung disease. It confers some of the advantages of tidal liquid breathing, yet it is easier to implement, is technically less daunting, and represents less of a departure from conventional CPPB.

There is, now, a medical grade perfluorocarbon possessing characteristics favorable for PAGE (LiquiVenttm); and potential human applications of this agent to tidal liquid breathing and PAGE may soon be explored.

It is likely that per-patient expense of this agent will be substantially lower than that of current approved pulmonary surfactants. Moreover, if perfluorocarbon technology does reduce the morbidity of ventilatory care, the secondary costs of intensive care may decline.

REFERENCES

- (1) JA Kylstra, CV Paganelli and EH Lanphier. Pulmonary gas exchange in dogs ventilated with hyperbarically oxygenated liquid. *J Appl Physiol* 21:177 (1966)
- (2) SE Curtis, BP Fuhrman, DF Howland. Airway and alveolar pressures during fluorocarbon breathing in infant lambs. *J. Appl. Physiol.* 68(6):2322-2328 (1990)
- (3) SE Curtis, BP Fuhrman, DF Howland, M DeFrancis, EK Motoyama. Cardiac output during liquid (fluorocarbon) breathing in newborn piglets. *Crit. Care Med.* 19(2):225-230 (1991)
- (4) MR Wolfson, N Tran, VK Bhutani, TH Shaffer. a new experimental approach for the study of cardiopulmonary physiology during early development. *J Appl Physiol* 65(3):1436-1443 (1988)
- (5) BP Fuhrman, PR Paczan, M DeFrancis. Perfluorocarbon associated gas exchange. *Crit Care Med* 19(5):712-723 (1991)
- (6) N Salman, BP Fuhrman, MC Papo, LJ Hernan, DM Steinhorn, CL Leach, P Paczan, B Burak, B Holm. Oxygenation and lung mechanics during 24 hour trials of perfluorocarbon associated gas exchange in normal piglets. *Ped Research* 33(4 Part 2):A226 (1993)
- (7) CL Leach, BP Fuhrman, FC Morin III, M Rath, L Hernan, B Holm, M Papo, D Steinhorn. Perfluorocarbon-associated gas exchange (PAGE) with perflubron (LiquiVenttm) in respiratory distress syndrome. *Ped Research* 33(4 Part 2):A1309 (1993)
- (8) M Papo, P Paczan, B Burak, B Holm, D Steinhorn, L Hernan, C Leach, B Fuhrman. A medical grade perfluorocarbon used during PAGE improves oxygenation and ventilation in a model of ARDS. *Pediatr Res* 33(4 Part 2):A219 (1993)
- (9) AE Thompson, BP Fuhrman, J Allen. Perfluorocarbon associated gas exchange (PAGE) in experimental meconium aspiration (MAS). *Ped Research* 33(4 Part 2):A1418 (1993)
- (10) FD Nesti, BP Fuhrman, MC Papo, DM Steinhorn, LJ Hernan, CL Leach, B Holm, P Paczan, B Burak. Perfluorocarbon associated gas exchange (PAGE) in gastric aspiration. *Pediatr Res* 33(4 Part 2):A 215 (1993)

**NON-INVASIVE PHYSIOLOGY:
¹⁹F NMR OF PERFLUOROCARBONS**

R. P. Mason,
Department of Radiology,
UT-Southwestern Medical Center,
Dallas, TX 75235-9058.

ABSTRACT

Ever since it was shown that the ¹⁹F NMR spin-lattice relaxation rates (R₁) of perfluorocarbon (PFC) emulsions are highly sensitive to oxygen tension (pO₂), there has been a developing interest in the use of PFCs to probe tissue physiology. Oxygen is required for efficient function by most tissues and hypoxia leads to rapid cellular dysfunction and damage. In addition, hypoxic tumor cells are refractory to radiotherapy. Thus, the opportunity to measure tissue oxygen tension non-invasively may be significant in understanding mechanisms of tissue function and in clinical prognosis. PFC NMR parameters are also sensitive to temperature, facilitating NMR thermometry with potential applications in hyperthermia studies. I will review the development of experimental techniques, applications to specific tissues and discuss the challenges and opportunities presented by ¹⁹F NMR of perfluorocarbons.

¹⁹F NMR

¹⁹F NMR is highly sensitive: the ¹⁹F isotope is 100% naturally abundant, has spin 1/2 and provides 83% the sensitivity of ¹H NMR. The proximity of ¹⁹F and ¹H NMR frequencies facilitates the use of existing equipment with only minor modification. Although fluorine may exist in the body at millimolar concentrations, it predominantly occurs immobilized in the bone matrix and there is essentially no

background signal to interfere with *in vivo* investigations. ^{19}F NMR exhibits a large chemical shift range and is highly sensitive to the micro-environmental milieu. Fluorine-labelled molecules have been developed to probe specific physiological parameters such as pH, metal ion concentrations and membrane potential [1, 2]. Perfluorocarbons offer exceptional sensitivity to oxygen tension and temperature.

PFCs are essentially inert and exhibit very high gas solubility. They are immiscible with water, but may be formulated as emulsions with pluronic or egg yolk phospholipids [3]. The possibility of transporting oxygen led to the development of biocompatible PFC emulsion blood substitutes [3]. Several commercial formulations are available and representative ^{19}F NMR spectra are shown in Fig. 1. Each emulsion has a unique multi-resonant spectrum, which is characterized by absolute (δ) and relative ($\Delta\delta$) chemical shifts, relative signal intensities and spin-lattice ($R_1 = 1/T_1$) and spin-spin ($R_2 = 1/T_2$) relaxation rates. Each of these parameters may be exploited in using PFCs to probe tissue physiology. The PFC of choice depends on characteristic NMR properties together with the usual considerations of emulsion stability, vascular retention, tissue targetability and ultimate clearance from the body.

Oxygen Tension

Oxygen is highly soluble in PFCs and solvation obeys Henry's law. The inherent paramagnetism of O_2 enhances NMR relaxation. Early studies in neat PFCs showed that the spin lattice relaxation rate for the ^{19}F NMR signal was given by $R_1 = a + b \cdot \text{pO}_2$ [4-7]. The same relationship has been confirmed by many investigators for PFC emulsions [2, 4, 6-28] at magnetic fields from 0.14 T to 7 T. At low field individual resonances are not always resolved, but the general relationship holds for individual resonances [2, 17, 20] or convoluted signals [6]. The specific relationship is unique for each individual resonance of a PFC (Fig. 2). The relative sensitivity to changes in pO_2 may be compared on the basis of $\eta = \text{slope}/\text{intercept}$ [29].

In order to exploit this relationship for measurements of pO_2 *in vivo* it is crucial to establish the validity of calibration curves obtained in solution and to consider what factors could interfere with the

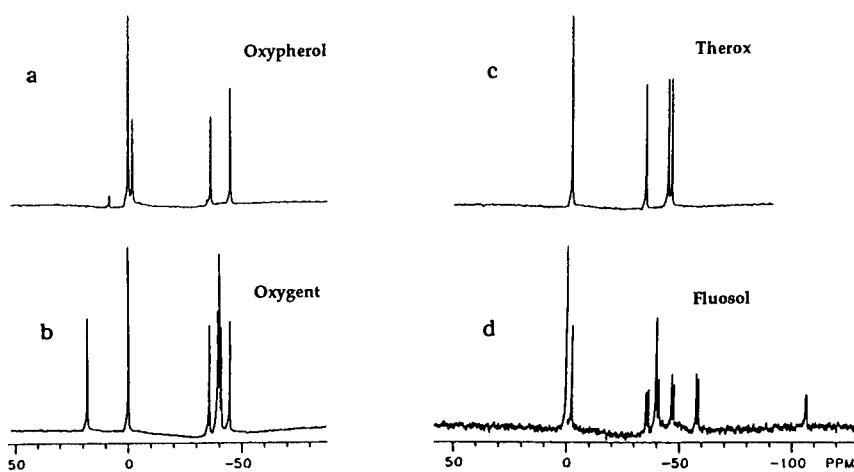
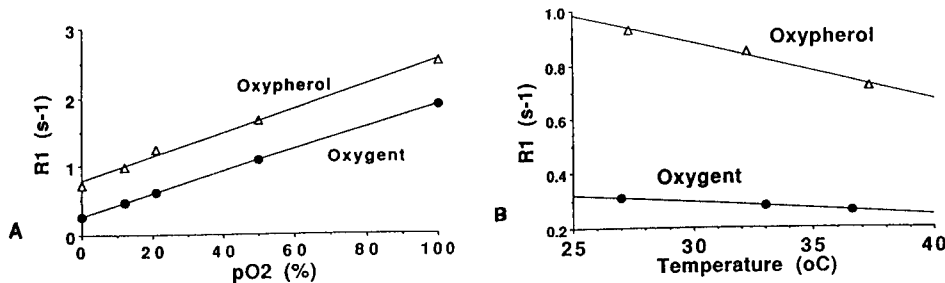

FIGURE 1 282 MHz ¹⁹F NMR spectra of commercial PFC emulsions: a) Oxypherol (20% w/v emulsion of perfluorotributylamine (PFTB), Alpha Therapeutics), b) Oxygent™ (90% w/v emulsion perflubron [perfluorooctyl bromide, PFOB], Alliance Pharmaceutical Corp.), c) Therox (40% w/v emulsion of trans-1,2 bis-(perfluorobutyl)-ethylene, Du Pont) and d) Fluosol (emulsion of 14% w/v perfluorodecalin and 6% w/v perfluorotripropylamine (PFTP), Alpha Therapeutics). CF₃ of each emulsion is essentially coincident and set to 0 ppm. There is some confusion in the literature regarding spectral assignments [12, 25, 31, 32] and it may be preferable to refer to resonances by their chemical shift. CF₂'s occur ~ 40 ppm upfield, whilst CF₂X (heteronucleus) are shifted downfield.

estimates. We have recently demonstrated that R₁ of Oxypherol sequestered in excised hypoxic tissue is identical to that in emulsion *in vitro* when pO₂ = 0% [20]. Some investigators have established R₁=f(pO₂) calibration curves by exposing minces of tissue containing PFC to various pO₂s [30]. We have now established independent evidence that R₁ of Oxypherol sequestered in whole tissue in the perfused heart responds to pO₂ identically with solution [20]. Briefly, a PFC loaded heart was excised and perfused. KCl arrest and cooling to 5 °C essentially stopped oxygen consumption by the tissue. When the pO₂ of the perfusate was varied in the range 0-95%O₂, R₁ values were identical with those obtained from free emulsion [20]. O₂ electrodes confirmed pO₂ in the perfusate and that the arterio-venous difference

**FIGURE 2**

A comparison of the sensitivity of R_1 to oxygen and temperature for the PFC emulsions OxygentTM (● CF₃) and Oxypherol[®] (Δ CF₃) at 4.7 T.

A) $R_1 = f(pO_2)$: R_1 (Oxygent) = $0.2677(\pm 0.0031se) + 0.0161(\pm 0.00006se)(\%pO_2)$, $\eta = 6$;

and R_1 (Oxypherol) = $0.779(\pm 0.04se) + 0.0175(\pm 0.0001se)(\%pO_2)$, $\eta = 2.2$ at 37 °C,

B) $R_1 = f(T)$: R_1 (Oxygent) = $0.444(\pm 0.0015se) - 0.00497(\pm 0.00005se)(^{\circ}C)$;

and R_1 (Oxypherol) = $1.50(\pm 0.08se) - 0.0209(\pm 0.0025se)(^{\circ}C)$ at 0% pO₂.

Oxygent is more sensitive to changes in pO₂ and less sensitive to changes in temperature [21, 27].

was zero [20]. It has also been shown that R_1 of PFCs is independent of emulsification [6, 7] or dilution [22] and is unaffected by changes in pH [9, 26], common proteins [9, 26, 33] or blood [25]. R_1 is unaffected by the presence of paramagnetic ions [4, 33], however, the presence of lipophilic paramagnetic species such as the spin label doxylstearate nitroxide did strongly influence R_1 [35]. The $R_1 = f(pO_2)$ relationship is field dependant [21, 35], requiring calibration curves to be established at the magnetic field of interest. Temperature influences the relationship and an error of 1 °C may be equivalent to 1% pO₂ or 7 torr [20], but this may be compensated by establishing the relationship $R_1 = f(pO_2, T)$ (*vide infra*).

Some of the earliest applications *in vivo* showed qualitative differences in PFC relaxation in the lungs and liver of animals when breathing air or oxygen [2, 34, 36]. Many early experiments used ¹⁹F MRI

of vascular PFC following infusion to a high fluorocrit (30-50% transfusion). Fishman *et al* measured pO₂ in rat liver, spleen, lung and tumor, and used projection images to avoid flow artifacts [10, 11]. Eidelberg *et al* mapped pO₂ in the cat brain and showed local changes in pO₂ following regional arterial occlusion [9, 37]. Higuchi *et al* investigated changes in cerebral pO₂ using ¹⁹F surface coil NMR spectroscopy [16]. By assuming a typical cerebral blood flow a correction was made to the R₁ estimates to compensate for flow artifacts [16].

PFC emulsions reside in the vasculature for several hours [32] in contrast to small molecules, which are subject to rapid renal clearance [38]. Thus, PFCs are finding a new application as probes of vascular volume [8, 39-42]. Emulsions are actively taken up by the RES (~90% accumulates in liver, spleen and bone marrow) [43]. Emulsion also accumulates in regions of inflammation [44-46] and to a lesser extent other normal organs [43-44]. This provides excellent ¹⁹F signal in the liver and spleen and has been proposed as a contrast method to delineate these organs [47]. In an attempt to enhance tumor uptake antibodies have been conjugated to emulsion particles [48, 49].

Following sequestration, PFC may remain in the body for days to years. Perflubron [PFOB] has a half life of ~ 3 days in the major organs versus 65 days for the perfluorotripropylamine component of Fluosol [45]. The immobilization of sequestered PFC in tissue avoids flow artifacts in determining relaxation parameters. Sequestered PFC has been used to measure pO₂ in rodent tumours [13, 17, 20, 21, 30, 50, 51], the perfused heart [18] and the liver [14, 15, 17, 19]. The administration of multiple doses of PFC emulsion enhances the concentration of PFC and thus, tissues which accumulate little PFC, such as tumors and the heart may be efficiently investigated. A recent 3-D MRI study of Oxypherol in a Dunning prostate tumor in a rat provides new evidence for pO₂ gradients within the tumor [50].

NMR spectroscopy provides enhanced temporal resolution. Using surface coil NMR spectroscopy, local measurement of pO₂ in the tumor has been achieved in 6 mins with an accuracy ~ 15 torr using Oxypherol [17]. Oxygen is considerably more sensitive to changes in pO₂ permitting an accuracy ~ 5 torr to be achieved, which is

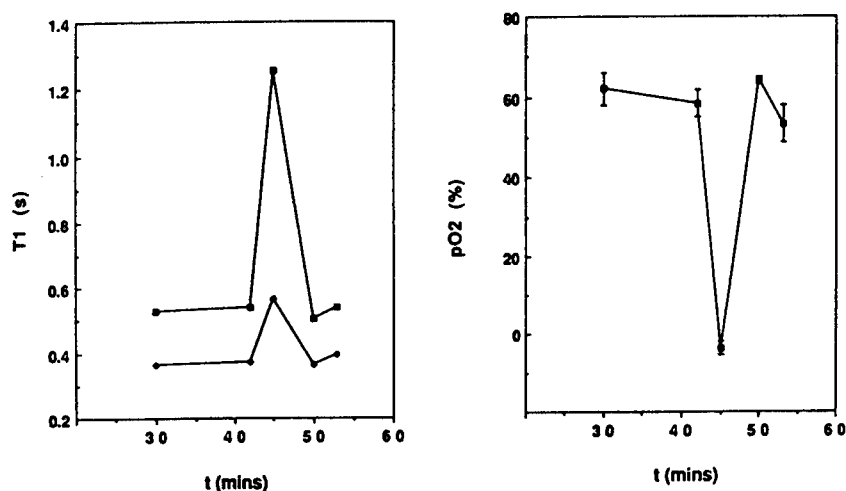

FIGURE 3 The variation of T_1 and calculated myocardial pO_2 with global ischemia and reperfusion for a perfused Oxypherol-loaded rat heart (Reproduced from Mason *et al* [18]). CF_3 □ and CF_2 ●.

radiobiologically significant [21]. Spectroscopy also provides independent estimates of pO_2 from each resonance and Fig. 3 shows a study in a perfused rat heart. The CF_3 resonance is considerably more sensitive than the CF_2 resonance, but the second estimate enhances confidence in the results [17, 18]. Rapid time resolution is crucial to monitor pO_2 dynamics as illustrated in Fig. 4. Using a 2-point spectroscopic R_1 determination, we have achieved a time resolution of 1.2 s in the perfused heart [18].

Spectroscopic studies may be localized using a surface coil with discrete radiofrequency field distribution, or by applying pulsed field gradients to interrogate specific voxels. Local R_1 and R_2 values have been estimated from volumes as small as 1 cc using VOSY in a porcine kidney perfused with Oxypherol [31].

Delivery of PFC to an organ of interest may be complicated by the tendency for RES uptake and impermeability of structures such as the blood brain barrier. Berkowitz *et al* have injected neat PFC directly into the eye to measure pre-retinal pO_2 [12, 52]. This provided discrete

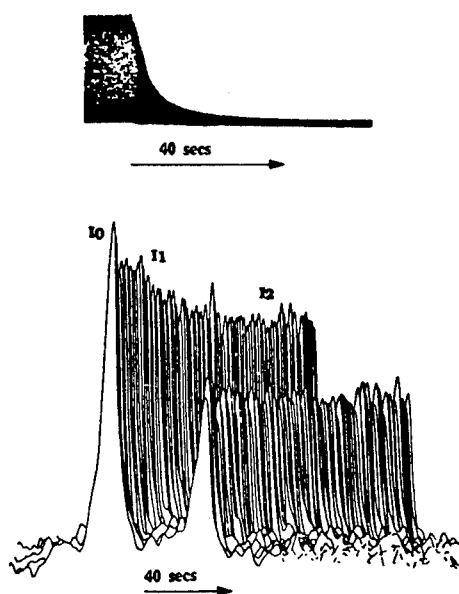

FIGURE 4 The variation of $p\text{O}_2$ during the onset of global ischemia in a perfused Oxypherol-loaded rat heart. There is a direct relationship between signal intensity (I) and tissue $p\text{O}_2$ for the series of partial saturation ^{19}F NMR spectra ($\text{TR}=1.2$ s.) The onset of ischemia causes rapid loss of signal intensity and hypoxia is evident within 40 s. The upper trace shows the corresponding ventricular pressure indicating close correlation between pressure and $p\text{O}_2$ and the importance of high temporal resolution (Reproduced from Mason *et al* [18]).

delivery and exceptional signal/noise. Experiments have examined full vitrectomy as well as bubbles of PFC as small as $2\ \mu\text{l}$. Investigations have examined both steady state and the kinetics of oxygen uptake and clearance [12, 52].

Using combined ^1H and ^{19}F MRI it has been shown that there is heterogeneous uptake of PFC emulsion by tumors with enhanced deposition around the tumor periphery, corresponding with regions of highest perfusion [50, 53]. Thus, ^{19}F NMR spectroscopic relaxation measurements are *de facto* localized to the region of tissue containing PFC. In a Dunning prostate rat tumor it has been shown that PFC remained localized over time as the tumor grew and retained its form

and distribution; new tumor tissue grew peripherally. Initially $pO_2 \sim 45$ torr, and two weeks after administration, PFC was relatively central in the tumor and was found to be hypoxic [53].

R_2 is also sensitive to pO_2 (Fig. 5) and may provide more efficient estimation of pO_2 by exploiting a multi-echo CPMG type sequence [22]. The relative merits of R_1 and R_2 indices of pO_2 have been examined and each has been used to monitor pO_2 in abscess with variation in inhaled gas [22, 54]. Estimation of R_2 may be complicated by J-modulation, but this can be avoided by selective excitation of the resonance of interest [55].

Thermometry

^{19}F chemical shift is temperature dependent [56-58], whilst being essentially independent of pO_2 [58]. Internal chemical shift differences in PFTB have been used to estimate temperature in the eye [58] and close correlation was found with measurements by thermocouple. The change ~ 1 Hz / $^{\circ}C$ is very small and requires well resolved lines [58]. Although the sensitivity of the internal chemical shifts of perflubron is similar (Fig. 6), the lines are better resolved and may therefore provide enhanced temperature definition, particularly at low field.

Another approach to NMR thermometry was based on the ratio of signals from cis and trans isomers of perfluorodecalin which varies with temperature [59-60].

Oximetry and Thermometry

Each ^{19}F resonance of a PFC exhibits a unique response to pO_2 and temperature and the relationships: $R_1(CF_3) = 1.647 - 0.021T + 0.027P - 0.000208PT$ and $R_1(CF_2[2 \text{ ppm}]) = 3.363 - 0.043T + 0.027P - 0.000284PT$ have been determined for Oxypherol at 7 T [20]. Since each resonance is derived from a single molecule and hence, must be at the same pO_2 and temperature, it is possible to solve the simultaneous equations and determine pO_2 and temperature simultaneously, and unambiguously, without *a priori* knowledge [20]. This has been exploited to measure pO_2 in mouse tumours, where temperature was unknown [13].

DISCUSSION

PFC's may be used as molecular amplifiers to measure pO_2 by ^{19}F NMR. Individual NMR parameters may be assessed or a combination

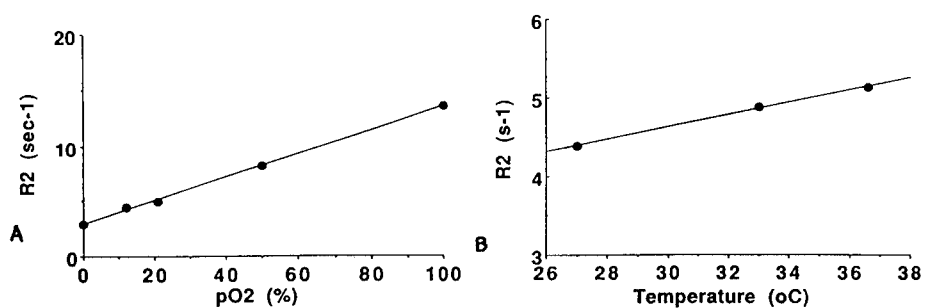

FIGURE 5 The variation of R₂ with pO₂ and temperature for the CF₂Br resonance of Oxygen at 4.7 T.

A) $R_2 = 2.907(\pm 0.106se) + 0.1056(\pm 0.0021se)(\%pO_2)$ at 27 °C.

B) $R_2 = 2.292(\pm 0.109se) + 0.0778(\pm 0.0033se)(°C)$ at 12.2 %pO₂.

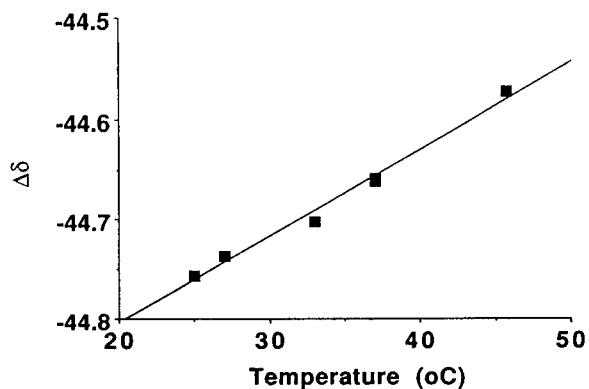

FIGURE 6 Internal chemical shift difference between the CF₃ and CF₂(-45 ppm) resonances of Oxygen at 4.7 T as a function of temperature at 0%pO₂:

$\Delta\delta = -44.977(\pm 0.017se) + 0.00865(\pm 0.00049se) °C.$

of R_1 , R_2 and chemical shift may be used to provide corroborative estimates of pO_2 and temperature. ^{19}F NMR of PFC is non-invasive and measurements may be global or localized. This contrasts existing techniques which are generally invasive and sample very localized regions only (*e.g.*, micro-electrodes) [61]. Shortly after IV infusion PFCs may be used to interrogate pO_2 in tissue vasculature [9, 10, 16]. Later when the material is sequestered tissue pO_2 is determined [13, 15, 17, 18]. Alternatively, direct administration by injection or inhalation has provided retinal [12, 52] or alveolar pO_2 [34]. The temporal resolution depends on the signal strength (tissue PFC concentration), the desired localization (regional pO_2) and the requisite accuracy of the determination. Localization may be achieved using tailored RF field gradients or using non-localized interrogation of discrete PFC distribution [52, 53]. The choice of experiment will depend on the biological phenomenon to be investigated. It may be optimal to measure pO_2 accurately with high spatial resolution as a baseline and then monitor dynamic changes very rapidly, albeit with some loss of definition. Technical improvements will enhance methodology; indeed, echo planar MRI holds the promise of sub-second pO_2 maps of the liver [62]. At the same time enhanced PFC emulsions with improved sensitivity to pO_2 , insensitivity to temperature and organ targetability ("stealth emulsions" avoiding the RES [3]) could enhance the utility for physiological studies.

PFC emulsions are already used clinically for coronary angioplasty and are undergoing clinical trials for further applications [3]. PFCs have been detected in patients with good sensitivity [63-65] suggesting that they may find application for diagnosis and prognosis in future.

ACKNOWLEDGEMENTS

I am grateful to the American Heart Association (Texas Affiliate) and Alliance Pharmaceutical Corp. for support and my colleagues for valuable discussions.

REFERENCES

- 1 B.S. Selinsky & C.T. Burt, *Biol. Magn. Reson.* 11: 241-275 (1992)

- 2 S.R. Thomas, p1536 in "Magnetic Resonance Imaging 2" (Partain *et al* Eds.) (2nd Ed.) WB Saunders Comp., Philadelphia (1988).
- 3 J.G. Riess, *Biomat. Art. Cells & Immob. Biotech.* 20: 183-202 (1992)
- 4 L.C. Clark *et al*, *Adv. Med. Biol.* 835-845, Plenum Press, New York (1984)
- 5 J-J Delpuech *et al*, *J. Chem. Phys.* 70: 2680-2687 (1979)
- 6 C-S. Lai *et al*, *J. Magn. Reson.* 57: 447-452 (1984)
- 7 P. Parhami & B.M. Fung, *J. Phys. Chem.* 87: 1928-1931 (1983)
- 8 P.M. Joseph *et al*, *J. Comp. Assist. Tomogr.* 9:1012-1019 (1985)
- 9 D. Eidelberg *et al*, *Magn. Reson. Med.* 6: 344-352 (1988)
- 10 J.E. Fishman *et al*, *Magn. Reson. Imaging* 5: 279-285 (1987)
- 11 J. E. Fishman *et al*, *Invest. Radiol.* 24: 65-71 (1989).
- 12 B.A. Berkowitz *et al*, *Magn. Reson. Med.* 21: 233-241 (1991)
- 13 P. S. Hees & C H. Sotak, *Magn. Reson. Med.* 29:303-310 (1993)
- 14 S. Holland *et al*, *Proc. 7th SMRM* (San Francisco) 526 (1988)
- 15 P. Boernert *et al*, *Magn. Reson. Med.* 29: 226-234 (1993)
- 16 T. Higuchi *et al*, *Proc. 7th SMRM* (San Francisco) 435 (1988)
- 17 R.P. Mason *et al*, *Magn. Reson. Med.* 18: 71-79 (1991)
- 18 R.P. Mason *et al*, *Magn. Reson. Med.* 27:310-317 (1992)
- 19 R.P. Mason *et al*, *Biomat Art Cells Immob Biotech* 20: 929-932 (1992)
- 20 R.P. Mason *et al*, *Magn. Reson. Med.* 29: 296-302 (1993)
- 21 R. P. Mason & P.P. Antich, "Tumor oxygen tension: measurement using OxygentTM as a ¹⁹F NMR probe at 4.7 T", this volume (1993)
- 22 R.F. Mattrey *et al* *Biomat Art Cells Immob Biotech* 20: 917-920 (1992)
- 23 R.S. Reid *et al*, *Phys. Med. Biol.* 30: 677-686 (1985)
- 24 K.A. McGovern *et al*, *Magn. Reson. Med.* 29: 196-204 (1993)
- 25 C.F. Kong *et al*, *J. Phys. Chem.* 88: 6308 (1984)
- 26 J. Taylor & C.J. Deutsch, *Biophys. J.* 53: 227-233 (1988)

- 27 H.P. Shukla *et al*, *41st Radiat. Res. Meeting,, Dallas TX*, P31-1 (1993)
- 28 C.H. Sotak *et al*, *Magn. Reson. Med.* 29: 188-195 (1993)
- 29 S.R. Thomas *et al*, *Proc. 7th SMRM (San Francisco)* 342 (1988)
- 30 N.J. Baldwin & T.C. Ng, *Proc. 11th SMRM (Berlin)* 3501 (1992)
- 31 G. Schnur *et al*, *Magn. Reson. Med.* 13: 478-489 (1990)
- 32 D. Malet-Martino *et al*, *J. Pharm. Pharmacol.* 36: 556-559 (1984).
- 33 S.R. Thomas *et al*, *Radiology* 18: 159 (1991)
- 34 S.R. Thomas *et al*, *J. Comp. Assist. Tomogr.* 10: 1 (1986).
- 35 R.M. Mueller *et al*, *Proc. 5th SMRM (Montreal)* 2: 327 (1986)
- 36 K. Yamada *et al*, *Sci. Rep. Res. Inst. Tohoku Univ.-c* 33: 1-4 (1986)
- 37 D. Eidelberg *et al*, *J. Cereb. Blood Flow Metab.* 8: 276-281 (1988)
- 38 V.D. Mehta *et al*, *BioMed. Chem. Letters* 2: 527-532 (1992)
- 39 C. Thomas *et al*, *J. Natl. Cancer Inst.* 84: 174-180 (1992)
- 40 T.L. Ceckler *et al*, *Magn. Reson. Med.* 13: 416 (1990)
- 41 D. Lu *et al*, *Magn. Reson. Med.* 29: 179-187 (1993)
- 42 B. Authier, *Magn. Reson. Med.* 8:80-3 (1988)
- 43 R. P. Mason *et al*, *Magn. Reson. Imaging* 7: 475-485 (1989)
- 44 H.E. Longmaid III *et al*, *Invest. Radiol.* 20: 141-145; 1985.
- 45 R.F. Mattrey & D.C. Long, *Invest. Radiol.* 23: s298-301 (1988)
- 46 E.E. Babcock *et al*, *Proc. 5th SMRM (Montreal)* 2: 382 (1986)
- 47 A.V. Ratner *et al*, *Magn. Reson. Med.* 5:548-554 (1987)
- 48 H. Mishima *et al*, *J. Magn. Reson. Imaging* 1:705-709 (1991)
- 49 M. Shimizu *et al*, *Magn. Reson. Med.* 5, 290 (1987)
- 50 R.P. Mason *et al*, *41st Radiat. Res. Meeting, Dallas TX*, P31-5 (1993)
- 51 H.C. Charles *et al*, *41st Radiat. Res. Meeting, Dallas TX* P31-4 (1993)
- 52 C.A. Wilson *et al*, *Exp. Eye Res.* 55: 119-126 (1992)

- 53 R.P. Mason *et al*, *Proc. 17th L.H. Gray Conf.*, Canterbury UK (1992)
- 54 Q. Guo *et al*, *Proc. 11th SMRM (Berlin)* 1445 (1992)
- 55 E.E. Babcock *et al*, *Magn. Reson. Med.* 17: 179-188 (1991)
- 56 J. Bornais & S. Brownstein, *J. Magn. Reson.* 29: 207-211 (1978)
- 57 K. Ute *et al*, *Chem. Letters* 1337-1340 (1992)
- 58 B. A. Berkowitz *et al*, *NMR in Biomed.* 5: 65-68 (1992).
- 59 L.C. Ackerman *et al* *Proc. 3rd SMRM* 1 (1984)
- 60 S.L. Dieckman *et al*, *Proc. 6th SMRM* 815 (1987)
- 61 H.D. Sostman *et al*, *Magn. Reson. Med.* 20: 253-267 (1991)
- 62 B.R. Barker *et al*, submitted (1993)
- 63 B.K.O. Gewiese *et al*, *Radiology* 185: 131-133 (1992)
- 64 C.A. Wilson *et al*, *Arch. Ophthalmol.* 110: 1098-100 (1992)
- 65 R.L. Nunnally *et al*, *Proc 7th SMRM* (San Francisco) 342 (1988)

II. POSTERS

**PHARMACOKINETICS AND TOLERANCE
OF WEEKLY OXYGENT™ CA INFUSIONS IN THE DOG**

C.J. Henry, W.G. Brewer, Jr., R.A. Henderson, W.R. Brawner; Auburn University College of Veterinary Medicine, Auburn University, Alabama, U.S.A 36849-5523

This study determined the OXYGENT™ CA (90% w/v perflubron emulsion, Alliance Pharmaceutical Corporation) dose necessary to achieve a 3 - 4% fluorocrit, and the tolerance of this dose administered once per week for four weeks to dogs. This study simulated OXYGENT™ CA use as a radiosensitizing agent. Six adult dogs were administered 6 ml/kg OXYGENT™ CA once per week for 4 weeks. Blood samples were collected following infusion, until fluorocrits were \leq 0.5%. One week after the fourth infusion, three dogs were necropsied. Liver biopsies were obtained from the remaining three dogs which were monitored 12 additional weeks. All dogs achieved fluorocrits $>$ 3.0% (3.5 - 5.1%) with the 6 ml/kg dose. A 3 ml/kg dose did not provide a fluorocrit $>$ 3.0%. Serum bilirubin concentrations were elevated at 24-hour sampling times and declined within 72 hours. Elevations in ALT, SAP, and bile acids were noted. Splenic and hepatic microvasculature fibrosis occurred in the long-term study dogs. Thrombocytopenia occurred in 5/6 dogs, necessitating exclusion of one dog from 2 infusions. However, 3/5 thrombocytopenic dogs had titers for *Ehrlichia sp.*, which elicits thrombocytopenia. Therefore, we cannot conclude the effect of OXYGENT™ CA on platelets.

INTRODUCTION

Tumor hypoxia causes radioresistance, limiting the success of solid tumor radiation therapy[1-4]. Intravenous perfluorochemical emulsion (Fluosol-DA 20% emulsion) and oxygen or carbogen breathing increases tumor radiosensitivity[5-10]. Preliminary data suggests that a newer perflubron (perfluorooctyl bromide [PFOB]) emulsion (Oxygent™, Alliance Pharmaceutical Corp.) may represent a safer, more stable, and effective alternative to Fluosol-DA 20% (Alpha Therapeutics) for use as a radiosensitizing and chemotherapy-enhancing agent[11-19]. This study determined the Oxygent™ CA dose necessary to achieve a 3 to 4% fluorocrit (volume percentage of fluorochemicals in blood) in dogs. The 3 to 4% fluorocrit was based on rodent studies[14]. The appropriate Oxygent™ CA dose was then administered, under conditions anticipated for clinical trial, to determine tolerance.

MATERIALS AND METHODS

dose study

Six normal, adult, mixed-breed dogs were chosen for dose determination studies following physical examination, complete blood counts, urinalyses, blood urea nitrogen (BUN), creatinine, bilirubin, and pre- and postprandial bile acid concentrations, and alanine aminotransferase (ALT) and alkaline phosphatase (SAP) activities. Only dogs with measured parameters within reference ranges were included in the study. Oxygent™ CA was administered intravenously (cephalic vein) to three dogs at a dose of 3 ml/kg and three dogs at a dose of 6ml/kg once per week for two weeks. Fluorocrits were determined 5, 10, 15, 30, 45, 60, 75, 90, and 105 minutes and 2, 3, 4, 5, 6, 8, 12, 18, 24, 30 and 36 hours post-infusion by standard methods[14]. If fluorocrits were <0.5% prior to the 36-hour sample, subsequent samples were not obtained.

tolerance and pharmacokinetic study

Six different dogs were chosen based on normal physical examinations, thoracic radiographs, EKG's, complete blood counts, serum biochemistry evaluations (BUN, creatinine, ALT, SAP, bilirubin), urinalyses, pre- and

postprandial bile acids, fecal examinations, and microscopic and antigen testing for *Dirofilaria immitis*. Oxygent™ CA (6 ml/kg) was administered intravenously (cephalic vein) once per week for 4 weeks. Fluorocrits were measured 15, 30, 45, 60, and 90 minutes and 2, 3, 4, 5, 6, 8, 12, 18, 24, 30, and 36-hours post-infusion, or until fluorocrits were <0.5%. In order to simulate conditions of a proposed clinical trial, dogs received intranasal oxygen at a flow rate of 5 liters/minute for one hour after Oxygent™ CA infusion. Additionally, dogs were pre-anesthetized with atropine sulfate (0.045 mg/kg subcutaneously) and anesthetized with acetylpromazine (Promace®, Fort Dodge)(0.05 mg/kg IV) and ketamine hydrochloride (Ketaset®, Fort Dodge)(10 mg/kg IV to effect, 1/4 dose at a time) on Monday, Wednesday, and Friday. In those dogs which did not achieve adequate anesthesia and immobilization, tiletamine hydrochloride/zolazepam hydrochloride (Telazol®, A.H. Robins)(2 mg/kg IV) was substituted. Complete blood counts, serum biochemistry evaluations (BUN, creatinine, ALT, SAP, bilirubin) and urinalyses were performed 24 and 72 hours after each infusion. Pre- and postprandial bile acids were measured weekly. Three randomly selected study dogs were euthanatized one week after administration of the final dose and necropsies were performed to monitor for acute pathologic lesions. Weekly laboratory evaluations were performed (CBC and platelet counts, urinalyses, bile acids and serum biochemistries as listed previously) on the three remaining dogs to determine reversibility of Oxygent™ CA-related biochemical abnormalities and late effects of infusion. Liver biopsies were obtained from these dogs by laparoscopy one week after the final Oxygent™ CA dose. The dogs were evaluated an additional 12 weeks, euthanatized, and necropsies were performed.

RESULTS

dose study

All dogs achieved fluorocrits > 3.0% (3.5 - 5.1%) with the 6 ml/kg Oxygent™ CA dose. The 3 ml/kg dose provided fluorocrits of 2.5 to 2.9%. Maximum fluorocrits were reached within 15 minutes of infusion. A

fluorochemical band was detected for 8 hours after infusion in the low-dose group and 36 hours in the high-dose group. Elimination curves plotted on semilog scale indicate similar slopes for both the 3 ml/kg and 6 ml/kg groups. Oxygent™ CA followed first-order elimination, with a set percent of the product eliminated from the blood per unit of time. Side effects of the 6 ml/kg dose were limited to vomiting within 90 minutes of infusion in two dogs and febrile responses ($T > 104^{\circ} F$) in two dogs, resolving by 18 hours post-infusion. One dog in the 3 ml/kg group vomited within 2 hours of infusion of the second dose.

tolerance and pharmacokinetic study

All dogs achieved flourocrits $> 3\%$ (3.0 - 4.75%) with each 6 ml/kg dose. Fluorochemical bands were undetectable in blood within 36 hours of infusion (range = 18 - 36 hours). First-order elimination was again observed. One dog received only two doses of Oxygent™ CA due to complications (see below). No acute side effects were noted following infusion, although anesthesia may have affected tolerance. Serum bilirubin concentrations were elevated (mean = 1.25 mg/dl; reference = 0.1 - 0.3 mg/dl) at 24-hour sampling times and declined (mean = 0.45 mg/dl) within 72 hours post-infusion. Serum alanine aminotransferase activity exceeded normal (reference = 17 - 66 IU/L) by week 3 (mean = 82.4 IU/liter), peaked (mean = 185 IU/L) during Week 12, and returned to normal (mean = 61.3 IU/L) by Week 13. Serum alkaline phosphatase activity exceeded normal (reference = 19 - 50 IU/L) within 24 hours of the first infusion (mean = 91.3 IU/L). Peak SAP activity (mean = 591.2 IU/L) was noted during week 4, and values exceeded the reference range for the remainder of the study. The reference range values for pre- and post-prandial bile acids (pre = 0.1 - 6.5 mg/dl ; post = 0.6 - 11.4 mg/dl) were exceeded within one week of the first infusion (mean pre = 14.5 mg/dl ; mean post = 15.2 mg/dl). Maximum values (mean pre = 16.1 mg/dl; mean post = 26.6 mg/dl) occurred during Week 7. Fibrosis of hepatic microvasculature and spleen was noted on necropsy specimens from long-term (4-month) study dogs. This fibrosis was not observed in the dogs euthanatized week 5, nor in the biopsy samples from long-term study dogs. Elevations in BUN and creatinine concentrations occurred after Oxygent™

CA administration. However, values remained within reference range. Decreased platelet counts were noted in five dogs after Oxygent™ CA infusion, and necessitated exclusion of one dog from the final two infusions. However three of the dogs exhibiting thrombocytopenia, including the dog excluded from two infusions, had positive titers for *Ehrlichia sp.*, which elicits thrombocytopenia. Mean platelet counts for *Ehrlichia*-negative dogs were within normal limits (200,000 - 900,000/mm³).

CONCLUSIONS

A 6 ml/kg Oxygent™ CA dose provides a fluorocrit > 3% in the dog. This dose produces few side effects. When the 6 ml/kg dose is administered once weekly for four weeks, liver enzyme elevations and increased pre- and postprandial bile acid concentrations occur. Fibrosis of hepatic microvasculature and spleen was present in two of three dogs three months after the last infusion, but is of unknown significance. Due to *Ehrlichia sp.* infection in three dogs, we were unable to draw conclusions regarding the effect of Oxygent™ CA on platelets. Further investigation of the long-term effects of Oxygent™ CA on hepatic function and platelets is warranted.

REFERENCES

1. M Horsman, J Overgaard. Overcoming tumour radiation resistance resulting from acute hypoxia. *Eur J Cancer*,28,717(1992).
2. JE Moulder, S Rockwell. Hypoxic fractions of solid tumors: experimental techniques, methods of analysis, and a survey of existing data. *Int J Radiat Oncol Biol Phys*,10,695(1984).
3. J Overgaard. Sensitization of hypoxic tumour cells-clinical experience. *Int J Radiat Biol*,56,801(1989).
4. P Vaupel, F Kallinowski, P Okunieff. Blood flow, oxygen and nutrient supply and metabolic microenvironment of human tumors:a review. *Cancer Res*,49,6449(1989).
5. T Hasegawa, JG Rhee, SH Levitt, CW Song. Increase in tumor pO₂ by perfluorochemicals and carbogen. *Int J Radiat Oncol Biol Phys*,13,569(1987).
6. R Lustig, N McIntosh-Lowe, C Rose, J Haas, S Krasnow, M Spaulding, L Prosnitz. Phase I/II study of fluosol-DA and 100% oxygen as an adjuvant to radiation in the treatment of advanced squamous cell tumors of the head and neck. *Int J Radiat Oncol Biol Phys*,16,1587(1989).

7. JE Moulder, BL Fish. Intermittent use of a perfluorochemical emulsion (Fluosol-DA 20%) and carbogen breathing with fractionated irradiation. *Int J Radiat Biol Phys*,15,1193(1988).
8. S Rockwell, TP Mate, CG Irvin, M Nierenburg. Reactions of tumors and normal tissues in mice to irradiation in the presence or absence of a perfluorochemical emulsion. *Int J Radiat Oncol Biol Phys*,12,1315(1986).
9. CM Rose, R Lustig, N McIntosh, B Teicher. A clinical trial of fluosol-DA 20% in advanced squamous cell carcinoma of the head and neck. *Int J Radiat Oncol Biol Phys*,12,1325(1986).
10. BA Teicher, CM Rose. Effects of dose and scheduling on growth delay of the lewis lung carcinoma produced by the perfluorochemical emulsion, fluosol-DA. *Int J Radiat Oncol Biol Phys*,12,1311(1986).
11. C Arlen, R Follana, M LeBlanc, C Long, D Long, JG Riess, A Valla. Formulation of highly concentrated fluorocarbon emulsions and assessment by near-total exchange perfusion of the conscious rat. *Biomat, Art Cells & Art Organs*,16,455(1988).
12. AR Burgan, WC Herrick, DM Long, DC Long. Acute and subacute toxicity of 100% PFOB emulsion. *Biomat, Art Cells & Art Organs*,16,681(1988).
13. DC Long, JG Riess, R Follana, A Burgan, RF Mattrey. Preparation and applications of highly concentrated PFOB emulsions. *Biomat, Art Cells & Art Organs*,16,441(1988).
14. S Rockwell, CG Irvin, M Kelley, CS Hughes, H Yabuki, E Porter, JJ Fischer. Effects of hyperbaric oxygen and a perfluorooctylbromide emulsion on the radiation responses of tumors and normal tissues in rodents. *Int J Radiat Oncol Biol Phys*,22,87(1992).
15. C Thomas, JG Riess, M Guichard. Influence of the 100% w/v perfluorooctylbromide (PFOB) emulsion dose on tumour radiosensitivity. *Int J Radiat Biol Phys*,59,433(1991).
16. S Rockwell, M Kelley, CG Irvin, CS Hughes, H Yabuki, E Porter, JJ Fischer. Preclinical evaluation of Oxygent™ as an adjunct to radiotherapy. *Biomat Art Cells & Immob Biotech*, 20,883(1992).
17. SA Holden, BA Teicher, C Ha, A Gulshan, TS Herman. Enhancement by perfusion emulsion (Oxygent®) and carbogen breathing of the tumor growth delay of the FSAIIC fibrosarcoma after treatment with antitumor alkylating agents. *Biomat Art Cells & Immob Biotech*,20,895(1992).
18. BA Teicher, TS Herman, K Menon. Enhancement of fractionated radiation therapy by an experimental concentrated perflubron emulsion (Oxygent®) in the Lewis lung carcinoma. *Biomat Art Cells & Immob Biotech*,20,899(1992).
19. JG Riess, JL Dalfors, GK Hanna, DH Klein, M-P Krafft, TJ Pelura, EG Schutt. Development of highly fluid, concentrated and stable fluorocarbon emulsions for diagnosis and therapy. *Biomat Art Cells & Immob Biotech*,20,839(1992)

ENHANCED OXYGEN DELIVERY BY PERFLUBRON EMULSION DURING ACUTE HEMODILUTION

P.E. Keipert, N.S. Faithfull, J.D. Bradley, D.Y. Hazard, J. Hogan[†],
M.S. Levisetti[†], and R.M. Peters[†]

Alliance Pharmaceutical Corp., San Diego, CA 92121, and

[†]Dept. of Surgery, University of California at San Diego, CA 92103.

ABSTRACT

A high-concentration 90% w/v perflubron (perfluorooctyl bromide [PFOB]) emulsion (*Oxygent™ HT*) is being evaluated as an oxygen carrier for use during surgery. This study was done to assess oxygen delivery by *Oxygent HT* during acute normovolemic hemodilution. Anesthetized mongrel dogs, instrumented with femoral and pulmonary artery catheters, were hemodiluted to a hematocrit of 25% with 3:1 (v/v) of Ringers-lactate (R-L). Dogs were then ventilated with 100% O₂ and hemodiluted to a Hct ~11% with 1.5 (v/v) of colloid (autologous plasma and 5% albumin). Dogs then received either 3.3 mL/kg *Oxygent HT* (n = 5) or 3.3 mL/kg R-L (n = 4), and were monitored for 3 hours. Total oxygen delivery (DO₂), blood oxygen content, cardiac output, mixed venous PO₂, and mixed venous Hb saturation was higher in *Oxygent HT* treated dogs compared to the R-L controls. The percentage of total DO₂ contributed by perflubron-dissolved oxygen was about 8-10% and accounted for 25-30% of total oxygen consumption (VO₂). The percentage of VO₂ contributed by Hb-carried oxygen was significantly higher in R-L controls (46 ± 4%) than in the treated dogs (15 ± 3%), indicating that the availability of the perflubron-dissolved oxygen allowed for a reserve of oxygen to remain available in the red blood cells.

INTRODUCTION

The development of perfluorochemical emulsions as oxygen carriers or "blood substitutes" is based on their gas transporting capability (1). *Oxygent™ HT* (Alliance Pharmaceutical Corp.), is a concentrated emulsion based on perflubron (perfluorooctyl bromide: C₈F₁₇Br) which is stable at room temperature. *Oxygent HT* is being evaluated for use as a temporary oxygen carrier during surgical procedures that use autologous blood transfusion techniques (e.g. predonation and intraoperative hemodilution). By enhancing oxygen delivery during surgery, the use of *Oxygent HT* will provide a margin of safety and allow for a delay in the re-infusion of the limited supply of autologous blood until later into or post-surgery, thereby reducing the potential exposure to allogeneic (donor) blood.

Oxygen carried by perflubron is physically dissolved and is present in the plasma compartment (i.e., not bound to hemoglobin inside red cells), making it more readily available for utilization by the tissues (2). Thus, using an oxygen carrier like *Oxygent HT* has the potential to provide a remarkable contribution to

total oxygen supply, especially when used during hemodilution (3). This study was designed to assess the oxygen delivery capability of a relatively low dose of a 90% w/v perflubron emulsion during acute normovolemic hemodilution.

MATERIALS and METHODS

The PFC emulsion tested in this study contained 90% w/v (~47% by volume) perflubron (perfluorooctyl bromide [PFOB]) and 4% w/v egg yolk phospholipid as the emulsifier, and had a mean particle size of about 0.25 μm . The emulsion was physiological with respect to osmolality and pH, was terminally heat-sterilized and was pyrogen free. The solubility of O_2 and CO_2 in the 90% perflubron emulsion (@ 760 mmHg; 37°C) is approximately 25 mL/dL and 100 mL/dL, respectively.

Mongrel dogs ($n = 9$) were intubated and ventilated with air under isoflurane anesthesia. Catheters were placed in both femoral arteries and veins, and a Swan-Ganz catheter (Oximetrix™) was inserted in the pulmonary artery to measure cardiac output (by thermodilution) and to collect mixed venous blood. Systemic and pulmonary blood pressures, and heart rate (from EKG) were monitored. Arterial and venous blood was analyzed for hematocrit, blood gases, and total oxygen contents (LexO₂Con, Hospex Fiberoptics, Chestnut Hill, MA).

Just prior to hemodilution, epinephrine (12.5 $\mu\text{g}/\text{kg}$) was given intravenously to contract the spleen to release sequestered red blood cells. Dogs were hemodiluted to a hematocrit (Hct) of 25%, by replacing shed blood with 3 volumes of Ringer's-Lactate (R-L). To mimic additional surgical blood loss, dogs were further hemodiluted to a target Hct of 10% while being ventilated with 100% O_2 , with shed blood being replaced with 1.5 vols of autologous plasma and albumin solution (5% albumin in R-L) to maintain plasma oncotic pressure. Animals were then randomly assigned to one of two groups: controls ($n = 4$; 18 ± 1 kg) were injected i.v. with 3.3 mL/kg of R-L while treated dogs ($n = 5$; 20 ± 2 kg) received 3.3 mL/kg of a 90% w/v perflubron emulsion (equivalent to 3.0 g perflubron/kg). Dogs were then monitored for a period of 3 hours. Blood perflubron levels were assayed by analytical gas chromatography.

RESULTS

All dogs tolerated profound hemodilution to Hct levels of ~10%. Figure 1 shows the significant cardiac output increase (as blood viscosity decreased (during progressive hemodilution), which tended to be higher in treated dogs. There were no significant differences between the two groups in pulmonary capillary wedge pressure or in mean systolic blood pressure. Intravascular retention of perflubron emulsion (by GC analysis) yielded a blood half-life of approximately 5 hours.

Both the arterial and venous oxygen contents were found to be higher in the perflubron-treated animals throughout the 3 hour monitoring period (data not shown). The combination of increased cardiac output with an increased oxygen carrying capacity in the blood of treated animals resulted in higher total oxygen delivery (475 ± 75 mL/min) compared to controls (320 ± 50 mL/min). Arterial PO_2 levels during ventilation on 100% oxygen ranged between 400 to 450 mmHg in both groups. As reported elsewhere (4), the mixed venous blood PO_2 (PvO_2) levels increased significantly to 108 ± 14 mmHg after injection of perflubron emulsion, while PvO_2 levels remained at 51 ± 2 mmHg in the R-L control dogs.

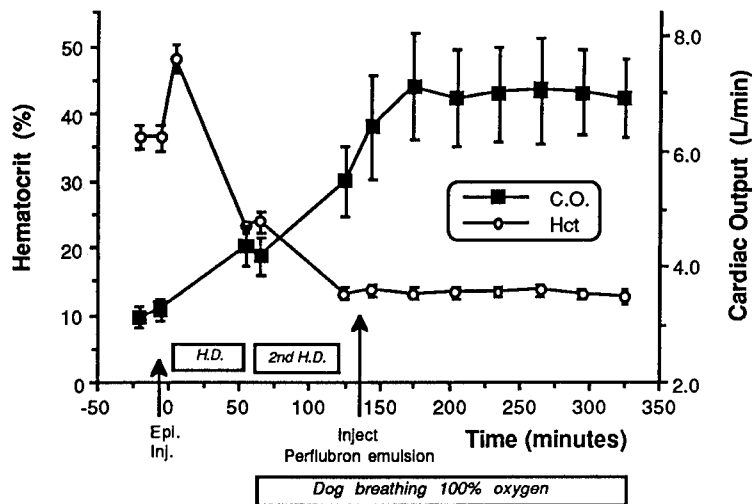

FIGURE 1. Hematocrit (Hct) and cardiac output (C.O.) in anesthetized dogs during and following normovolemic hemodilution (HD). The low starting Hct (<40%) was due to sequestering of red cells in the spleen. The spleen was contracted with i.v. epinephrine (12.5 μ g Epi/kg BW). Data shown are Means \pm SEM (n = 5 dogs).

As shown in Figure 2, significantly higher mixed venous oxyhemoglobin saturation levels were present in the perflubron-treated animals throughout the 3 hour monitoring phase, as a consequence of the elevated mixed venous PvO_2 in these animals. Total oxygen consumption (VO_2), shown in Figure 3, was not affected by infusion of perflubron emulsion and was maintained at normal levels in both groups. Oxygen dissolved only in perflubron accounted for 8-10% of the total oxygen delivery, and because of the high oxygen extraction coefficient for perflubron, accounted for 25-30% of VO_2 . The percent of VO_2 contributed by only the oxygen extracted from hemoglobin was significantly lower for the treated dogs ($15 \pm 3\%$) compared to R-L controls ($46 \pm 4\%$).

DISCUSSION

During surgery, the use of a PFC-based oxygen carrier might effectively augment oxygen delivery (5). Because venous oxygen tension remains high in the presence of PFCs, a persistently larger oxygen gradient will exist between blood and tissues, thereby facilitating diffusion of oxygen to the tissues (2). If red blood cells lost during surgery were replaced temporarily by an oxygen carrier with a limited half-life in the blood, then the need for autologous blood transfusion could be delayed and the autologous blood might not be wasted during periods of acute

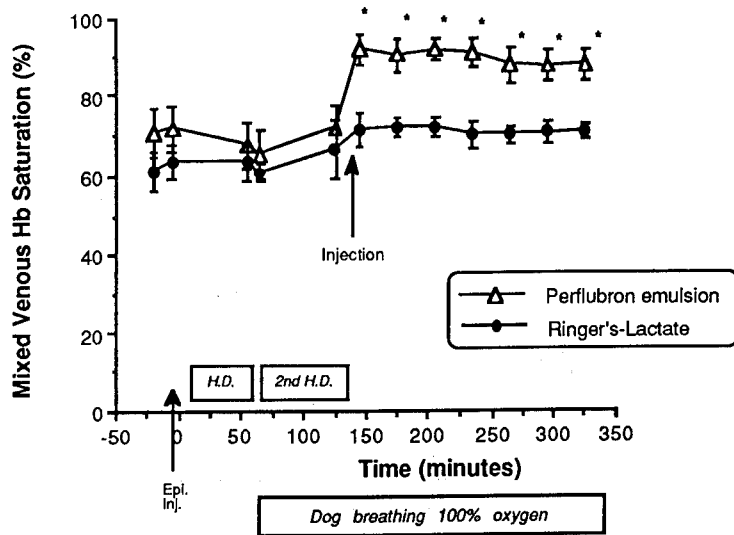

FIGURE 2. Mixed venous blood Hb saturation levels in anesthetized dogs during and following normovolemic hemodilution. Injection time for the dose of perflubron emulsion ($n = 5$) or Ringer's-Lactate ($n = 4$) after the hemodilution (HD) is indicated by the arrow. *Indicates a significant difference between groups. Data shown are Means \pm SEM.

intraoperative blood loss. This could have a significant impact on decreasing the likelihood of allogeneic blood transfusions in many surgical procedures (6).

The results of this study demonstrated that after profound hemodilution in dogs, a relatively low dose of a 90% w/v perflubron emulsion (*Oxygent™ HT*) could increase total oxygen delivery by ~40%. Due to the hemodilution, large increases in cardiac output (>100%) were observed in both groups. Mixed venous PO_2 levels and mixed venous oxygen saturation were elevated significantly in the perflubron-treated animals. Total oxygen delivery was approximately 35% to 50% higher in dogs receiving perflubron emulsion, although total VO_2 did not differ significantly between groups. The higher oxygen delivery in perflubron-treated dogs resulted from a combination of 30% higher cardiac output and a 10% higher arterial oxygen content. Perflubron-dissolved oxygen accounted for about 25-30% of total VO_2 , resulting in a considerable sparing of oxygen extraction from hemoglobin. The percentage of VO_2 contributed by the hemoglobin-carried oxygen was, therefore, significantly lower in the perflubron emulsion-treated dogs than in controls (4).

Figure 4 compares the sigmoid-shaped oxyhemoglobin dissociation curve of whole blood to the linear dissociation curve for *Oxygent HT*. Since PFCs obey

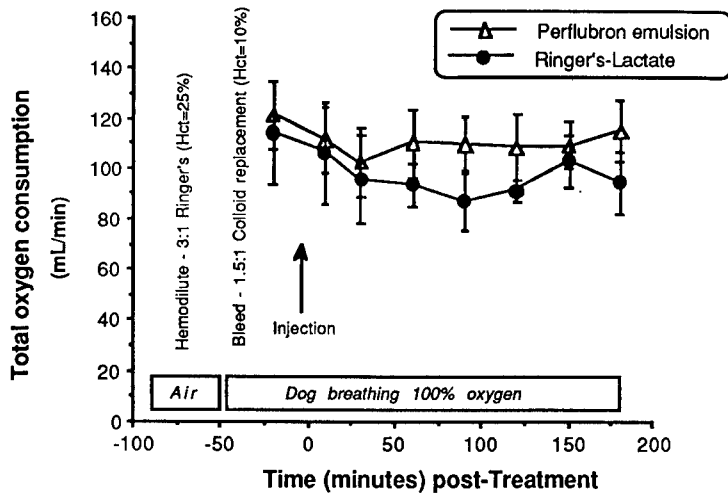

FIGURE 3. Total oxygen consumption (VO_2) in anesthetized dogs following acute normovolemic hemodilution. Injection time for the dose of perflubron emulsion ($n = 5$) or Ringer's-Lactate ($n = 4$) after hemodilution (HD) is indicated by the arrow. Data shown are Means \pm SEM.

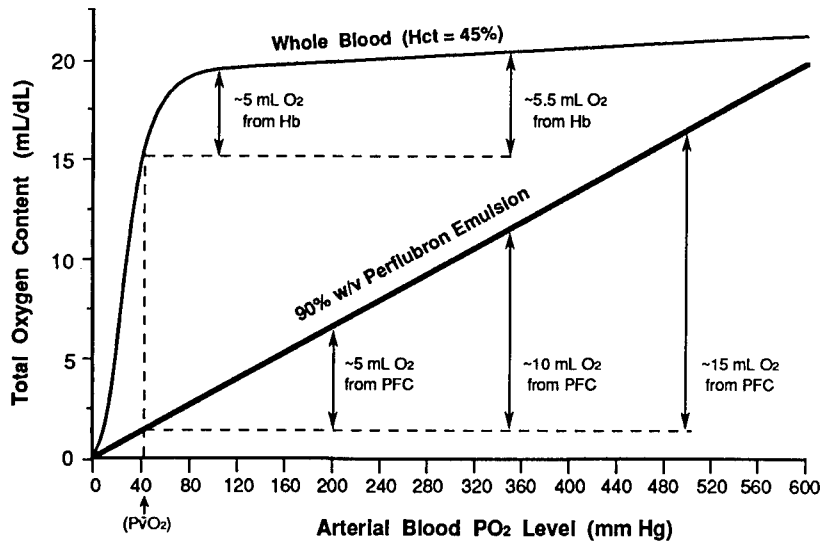

FIGURE 4. Comparison of the oxygen dissociation curves for a 90% w/v perflubron emulsion (*Oxygent HT*) and whole blood. The arrows indicate the potential delivery of oxygen (on an equal volume basis) at different arterial PO_2 levels. (Note: The solubility of oxygen in PFCs obeys Henry's law and depends only on the surrounding PO_2 .)

Henry's law, the amount of dissolved oxygen they can carry depends on the PO_2 . As indicated by the arrows in Fig. 4, PFCs will deliver 2 to 3 times more oxygen than whole blood (on an equal volume basis) at elevated PO_2 levels. Moreover, the utilization of oxygen (i.e., VO_2) will come preferentially from PFC-dissolved oxygen which is more readily available than oxygen bound to Hb inside red blood cells. Thus, any increase in PaO_2 will increase the amount of oxygen dissolved in the PFC emulsion carried in the blood. The same does not apply to hemoglobin. At a PaO_2 of 100 mmHg Hb is almost fully saturated, meaning that at elevated PO_2 levels no additional oxygen can be carried bound to Hb and no oxygen will be released from Hb. In the absence of PFCs, increased PaO_2 levels (i.e., >100 mmHg) will only add to the blood, a small additional amount of oxygen dissolved in the plasma itself.

PFC emulsions have a very high oxygen extraction coefficient when the animals are breathing gases with high concentrations of oxygen. This means that between a PaO_2 of 400 mmHg and a PvO_2 of 100 mmHg, the PFC emulsion will deliver its oxygen before any oxygen bound to hemoglobin gets released. Thus, *Oxygent HT* provides a means for significantly increasing the amount of oxygen carried in blood when the PaO_2 is raised above 90-100 mmHg. By serving as the first dispenser of oxygen, the PFC-dissolved oxygen protects the oxyhemoglobin saturation levels. Consequently, this leaves more Hb-bound oxygen (inside red cells) to act as a reserve of oxygen, which represents a margin of safety during hemodilution or acute blood loss that can be provided by PFC-carried oxygen.

These results have demonstrated that a relatively low dose of an oxygen-transporting perflubron emulsion can improve the overall oxygenation status in the acutely anemic dog. Since the mixed venous PO_2 can be regarded as a good clinical indicator of tissue PO_2 , then treatment with a PFC-based oxygen carrier like *Oxygent HT* would appear to improve the oxygenation status of the tissues during hemodilution. Such a technique could provide a margin of safety against excessive anemia during surgical procedures in which the red cell mass has been lowered by intentional autologous blood collection or intraoperative blood loss.

REFERENCES

1. J.G. Riess. Fluorocarbon-based in vivo oxygen transport and delivery systems. *Vox Sanguinis* 61:225 (1991).
2. N.S. Faithfull. Oxygen delivery from fluorocarbon emulsions - aspects of convective and diffusive transport. *Biomat., Artif. Cells, Immob. Biotech.* 20: 797 (1992).
3. D.K. Harrison, H. Günther, H. Vogel, R. et. al. Oxygen supply and microcirculation of the beating dog heart after haemodilution with Fluosol-DA 20%. *Adv. Exper. Med. Biol.* 191:445 (1985).
4. P.E. Keipert, N.S. Faithfull, J.D. Bradley, et. al. Oxygen delivery augmentation by low-dose perfluorochemical emulsion during profound normovolemic hemodilution. *in: "Oxygen Transport to Tissues XV,"* P. Vaupel, ed., Plenum Press, New York: (1993) (in press).

5. K.C. Lowe. Synthetic oxygen transport fluids based on perfluorochemicals: Applications in medicine and biology. *Vox Sanguinis* 60:129 (1991).
6. T.F. Zuck and P.M. Carey, Autologous transfusion practice, *Vox Sanguinis* 58:234 (1990).

INFLUENCE OF PERFLUBRON EMULSION PARTICLE SIZE ON BLOOD HALF-LIFE AND FEBRILE RESPONSE IN RATS

P.E. Keipert, S. Otto, S.F. Flaim, J.G. Weers, E.A. Schutt,
T.J. Pelura, D.H. Klein, and T.L. Yaksh[†]

Alliance Pharmaceutical Corp., San Diego, CA 92121, and

[†]Dept. of Anesthesiology, University of California at San Diego, CA 92093.

ABSTRACT

Perfluorochemical (PFC) emulsions are particulate in nature and, as such, can cause delayed febrile reactions when injected intravenously. This study investigated the influence of emulsion particle size on intravascular retention and on body temperature changes in unrestrained conscious rats. Concentrated (60% to 90% w/v) emulsions based on perflubron (perfluorooctyl bromide [PFOB]) with mean particle sizes ranging from 0.05 μm to 0.63 μm were tested. Rats were fitted with a chronic jugular catheter and an abdominal body temperature telemetry unit. Fully recovered, conscious rats were monitored for 24 hours after infusion (dose = 2.7 g PFC/kg). Emulsion blood half-life ($T_{1/2}$) was determined from blood perflubron levels measured by gas chromatography. Emulsions with a particle size of 0.2-0.3 μm caused fevers (6 to 8 hour duration) which peaked at 1-1.5°C above normal (~37.5°C). Fevers could be blocked by i.v. treatment with either cyclooxygenase inhibitors (ibuprofen) or corticosteroids (dexamethasone). Both intensity and duration of the temperature response, quantified by area under the temperature curve, was decreased significantly for emulsions with a particle size \leq 0.12 μm . Blood $T_{1/2}$ varied inversely with particle size, and was 3 to 4 fold longer for emulsions with a mean particle size \leq 0.2 μm . Thus, smaller emulsion particles more effectively evaded the reticuloendothelial system, which resulted in longer intravascular retention, less macrophage activity, and reduced febrile responses.

INTRODUCTION

Perfluorochemical (PFC) emulsions are presently being evaluated for use as oxygen carriers (1,2) or temporary "blood substitutes," due to their exceptional gas transporting capabilities. A concentrated emulsion, *Oxygent™ HT* (Alliance Pharmaceutical Corp.), based on perflubron (perfluorooctyl bromide: $\text{C}_8\text{F}_{17}\text{Br}$), is being developed for use during surgical procedures which use autologous blood transfusion techniques (e.g., predonation and acute normovolemic hemodilution) as a means to reduce exposure to allogeneic (donor) blood (3).

PFC emulsions, like other particulates, have been shown to occasionally cause delayed febrile reactions when injected intravenously in certain species and in humans (4). The basis of this reaction is related to the normal clearance of PFC emulsion particles from the circulation by blood leukocytes and phagocytic cells of the reticuloendothelial system (5). This study was designed to investigate the

influence of emulsion particle size on intravascular retention and the magnitude of the delayed febrile response. To obtain body temperature data that was unaffected by stress-induced endogenous responses, a sensitive animal model was developed using radio telemetry to monitor fully conscious, unrestrained rats.

MATERIALS and METHODS

Several high concentration (60% to 90% w/v total PFC) emulsions based on perflubron (perfluorooctyl bromide [PFOB]) with different mean particle sizes were required for this study. To produce these emulsions, three variables were manipulated: (a) the total amount of primary surfactant (egg yolk phospholipid) varied from 1% to 10%, (b) a second high molecular weight lipophilic PFC (e.g. C₁₀F₂₁Br) was added to perflubron to stabilize particle size (by suppressing Ostwald ripening [6]), and (c) different processing conditions (including pressure, temperature, and degree of homogenization) were used. Emulsion particle size was measured by centrifugal field flow fractionation on a Horiba CAPA 700 (7). Emulsions were terminally sterilized, were pyrogen free, and had physiological osmolality and pH.

One day prior to treatment, male Sprague-Dawley rats (320 ± 40 g) were fitted with a jugular catheter (exteriorized in the dorsal cervical region) for blood sampling and infusion. The catheter consisted of 4 cm of silicone tubing stretched over PE50 polyethylene Intramedic tubing (Clay Adams, B-D, Rutherford, NJ), and was primed with heparinized (0.1 IU/mL) saline. For febrile response studies, rats were additionally fitted with a body temperature telemetry transmitter (TA10TA-F40, Data Sciences Inc., St. Paul, MN) inserted into the peritoneal cavity via a 2 cm midline abdominal incision. Fully recovered, instrumented animals were housed individually in isolation chambers, and had access to food and water *ad libitum*. Following i.v. infusion with perflubron emulsion (dose = 2.7 g PFC/kg), conscious rats were monitored continuously for body temperature changes from -2 hours (preinfusion) to 20 hours post-infusion, with the data being collected every 5 minutes using Dataquest software. Data was averaged over 15 minute intervals and plotted as changes from the pretreatment baseline. The emulsion blood half-life (T_{1/2}) was determined by collecting blood samples (at 0.5, 1, 3, and 6 hours postdosing) and assaying for perflubron levels by analytical gas chromatography.

RESULTS

A variety of perflubron-based high concentration emulsions were made which had mean particle diameters ranging from 0.05 µm to 0.63 µm. By varying only the egg yolk phospholipid (EYP) surfactant content (i.e., 1%, 2%, 4% and 10% w/v), a series of four perflubron-based emulsions were made having mean particle sizes of 0.63 µm, 0.31 µm, 0.17 µm and 0.12 µm, respectively. In Figure 1, the blood levels in rats for these four emulsion are compared. The initial rate of clearance of the emulsion particles from blood during the first hour was clearly related to particle size, whereas later clearance rates from 1 to 6 hours were more similar (i.e., based on the slopes of the curves).

Significant prolongation in blood half-life was observed for all the smaller particle size emulsions. Figure 2 shows the significant differences in blood half-life values obtained for the emulsions with particle sizes ≤ 0.12 µm (T_{1/2} = 6 to 10 hours) and those ranging from 0.13 to 0.20 µm (T_{1/2} = 3 to 6 hours), compared to the larger particle size (> 0.21 µm) emulsion formulations (T_{1/2} = 1 to 3 hours).

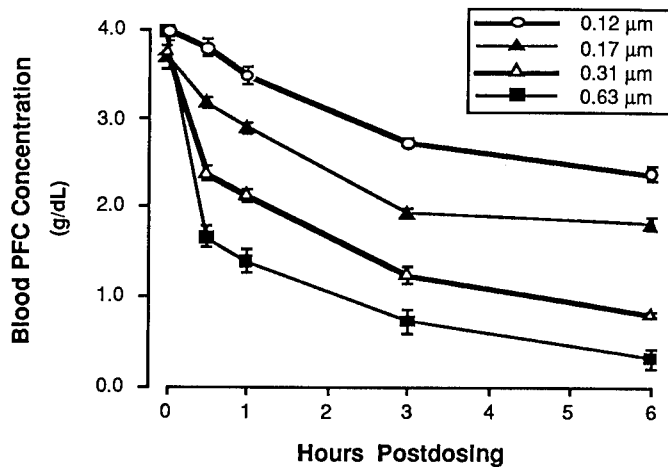

FIGURE 1. Blood perflubron levels in conscious rats following intravenous infusion of 90% w/v PFC emulsions at a dose of 3.0 mL/kg (2.7 g PFC/kg). Emulsions varied only in the total amount of surfactant. Blood was analyzed for perflubron content by analytical gas chromatography. Data shown are Means \pm SEM (n = 4 rats/group). Data shown are Means \pm SEM.

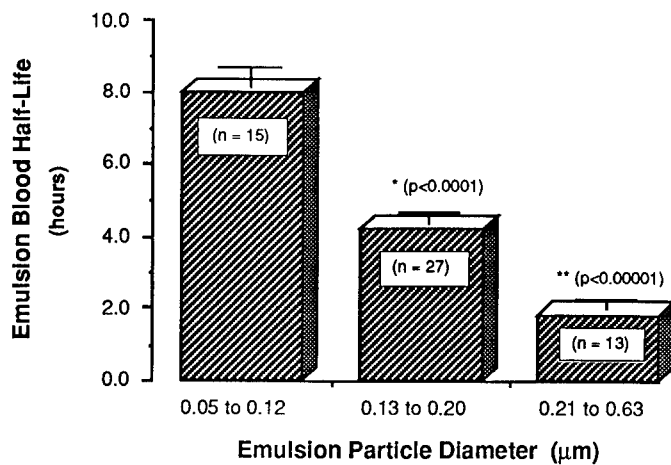

FIGURE 2. Blood half-life of perflubron-based emulsions in rats (n = 3 per emulsion) as a function of mean particle diameter. Emulsions (grouped by mean particle size) were prepared by varying total PFC and surfactant amounts, and the processing conditions. *Indicates a significant difference from 0.05 to 0.12 μm group. **Indicates a significant difference compared to other two groups. Data shown are Means \pm SEM for the number of emulsion indicated in each bar.

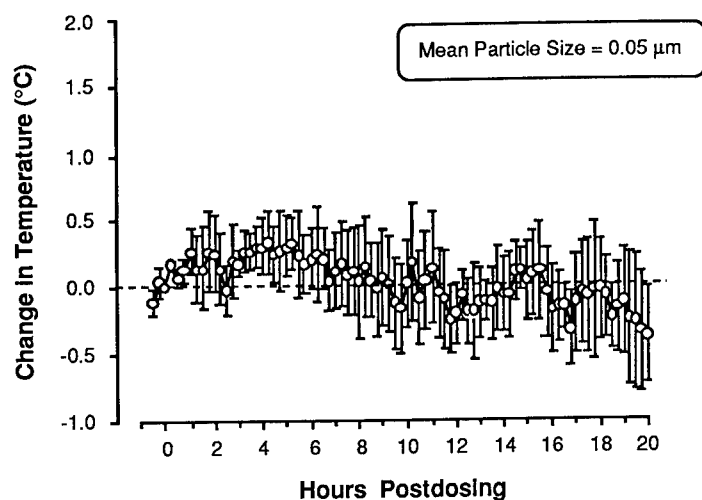

FIGURE 3. Body temperature changes (from normal pretreatment baseline = 37.5°C) in conscious, unrestrained rats after injection of a perflubron-based emulsion (dose = 2.7 g PFC/kg) with a very small particle size. Data shown are Means \pm SEM ($n = 4$ rats).

Standard 90% w/v perflubron emulsions with mean particle diameters of 0.2 to 0.3 μm produced a delayed fever in this rat model (onset at ~ 2 hours post infusion) which peaked at 1.0 to 1.5°C above the baseline ($\sim 37.5^\circ\text{C}$) and which resolved within 6-8 hours. These fevers could be blocked by pretreatment with corticosteroids (e.g. dexamethasone; 0.2 mg/kg i.v. @ -12 and -2 hours prior to emulsion infusion) or by treating with a long-acting cyclooxygenase inhibitor (e.g. ibuprofen; 1 mg/kg i.v.). As shown in Figures 3 and 4, the magnitude of the febrile response was very different for emulsions with extremely different particle sizes. There was essentially no delayed febrile response to the 0.05 μm particle emulsion (Fig. 3), whereas the 0.63 μm particle emulsion produced a significant, prolonged febrile response (Fig. 4).

DISCUSSION

Since perfluorochemical (PFC) emulsions are particulate in nature, they are cleared from the circulation by blood leukocytes and by phagocytic cells of the reticuloendothelial system (RES). As part of this normal clearance, cells such as macrophages can release cytokines which, in turn, could produce some of the flu-like symptoms (e.g., fever) which have been observed in humans and certain animal species following intravenous injection of high concentration perflubron-based emulsions (4,5). The particle size of PFC emulsions could therefore be

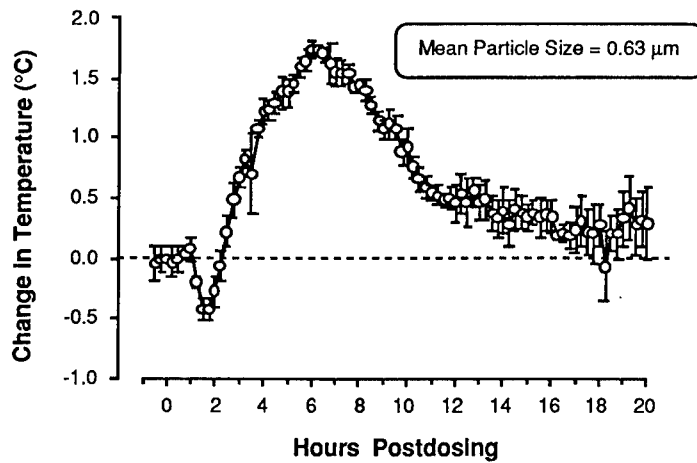

FIGURE 4. Body temperature changes (from normal pretreatment baseline = 37.5°C) in conscious, unrestrained rats after injection of a perflubron-based emulsion (dose = 2.7 g PFC/kg) with a very large particle size. Data shown are Means ± SEM (n = 4 rats).

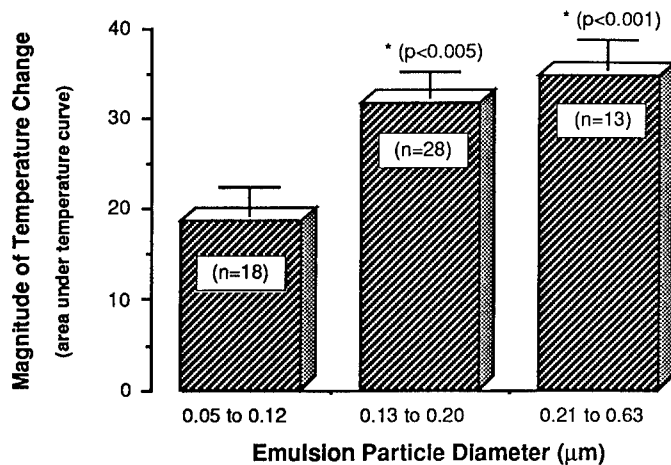

FIGURE 5. Comparison of the magnitude of temperature changes (both duration and intensity, quantified by the area under the temperature curve [AUC]) seen in unrestrained, conscious rats following injection of perflubron-based emulsions (dose = 2.7 g PFC/kg) having different mean particle size ranges. *Indicates significant difference compared to the small particle size (0.05 to 0.12 μm) group. Data shown are Means ± SEM for the number of emulsions indicated in each bar.

expected to have an influence on how readily the RES will recognize and clear these emulsion particles from the circulation.

Results from this study demonstrated clearly that emulsion blood half-life was significantly prolonged for those emulsions with smaller size particles. The intermediate particle size perflubron-based emulsions (0.13 to 0.20 μm diameters) had blood half-lives which were > 2-fold longer than larger particle size (> 0.20 μm) emulsions, but were only about half as long as the emulsions with very small particles ($\leq 0.12 \mu\text{m}$). In addition, the magnitude (i.e., intensity and duration) of the delayed febrile responses, quantified by the area under the temperature curve (AUC), was affected by the size of the emulsion particles. As shown in Figure 5, emulsions with very small particles ($\leq 0.12 \mu\text{m}$) were associated with significantly lesser febrile responses (mean AUC < 20) compared to the fever responses (mean AUC > 31) observed with emulsions having larger sized particles ($\geq 0.21 \mu\text{m}$).

From these data it has been demonstrated clearly that the mean diameter of emulsion particles has a significant influence on both the intravascular retention (i.e., blood half-life) and the magnitude of the febrile response characteristically observed following intravenous infusion of particulate products. Since smaller particles remain in the circulation longer, they must be more effective at evading clearance by the phagocytic cells of the RES. Thus, the smaller particle size emulsion formulations could presumably be causing less macrophage stimulation, which could explain the reduced febrile responses observed with the perflubron-based formulations in this study.

ACKNOWLEDGMENTS

The authors would like to express their sincere appreciation and thanks to K.M. Mackley, G.L. Luena, and R.C. Jones for their individual contributions and technical assistance.

REFERENCES

1. K.C. Lowe. *Vox Sanguinis* 60:129 (1991).
2. J.G. Riess. in: *Blood Substitutes and Oxygen Carriers*, T.M.S. Chang (ed), Marcel Dekker Inc., New York, p. 24 (1993).
3. P.E. Keipert, N.S. Faithfull, J.D. Bradley, et. al. *Biomat., Artif. Cells, Immob. Biotech.* 21: These proceedings (1993).
4. S.F. Flaim, D.R. Hazard, J. Hogan, and R.M. Peters. *Invest. Radiol.* 26:S122 (1991).
5. S.F. Flaim. *Biomat., Artif. Cells, Immob. Biotech.* 21: These proceedings (1993).
6. J.G. Weers, J. Liu, T. Fields, P. Resch, J. Cavin, and R.A. Arlauskas. *Biomat., Artif. Cells, Immob. Biotech.* 21: These proceedings (1993).
7. D.H. Klein, D.B. Burtner, L.A. Trevino and R.A. Arlauskas. *Biomat., Artif. Cells, Immob. Biotech.* 20: 855 (1992).

**ROOM TEMPERATURE STABLE PERFLUOROCARBON
EMULSIONS WITH ACCEPTABLE HALF-LIVES IN THE
RETICULOENDOTHELIAL SYSTEM**

J.G. Weers, J. Liu, T. Fields, P. Resch, J. Cavin and R.A. Arlauskas
Alliance Pharmaceutical Corp., San Diego, California, U.S.A.

ABSTRACT

Prolonged room temperature stability (i.e. zero particle growth) can be achieved for concentrated emulsions of perflubron (perfluorooctyl bromide) or perfluorodecalin via addition of a secondary high molecular weight, lipophilic fluorocarbon component. Due to their enhanced lipophilic character, the secondary fluorocarbon components have acceptable half-lives in the organs of the reticuloendothelial system.

INTRODUCTION

The primary mechanism of growth for small particle fluorocarbon emulsions is Ostwald ripening, a process which results from the isothermal distillation of fluorocarbon molecules between dissimilar droplets through the continuous phase [1]. The driving force for the growth is the small difference in fluorocarbon water solubility which exists between different sized droplets due to differences in their radius of curvature (Kelvin effect). Smaller, more highly curved droplets exhibit greater Laplace pressure, and hence greater water solubility, leading to growth of larger droplets at the expense of the smaller droplets. Water solubility of fluorocarbons generally decreases with increasing molecular weight, such that emulsions made from high molecular weight fluorocarbons are more stable than those made with low molecular weight fluorocarbons. The formulation of

fluorocarbon emulsions for medical applications must also take into account the biocompatibility of the formulation. Although fluorocarbon emulsion stability increases with increasing fluorocarbon molecular weight, so too does the half-life of the material in the organs of the reticuloendothelial system (RES). Achieving acceptable emulsion stability without substantially prolonging the RES half-life is a dilemma that has confounded formulators of fluorocarbon emulsions for over 25 years [2].

Higuchi and Misra [3] were the first to propose a method to slow Ostwald ripening in emulsions. The method involves the addition of a high molecular weight, low water solubility secondary oil to the disperse phase. The minimally water soluble oil reduces the total mixture solubility. Upon storage, the high water solubility component moves from the smaller droplets to the larger ones, creating a situation whereby the smaller droplets are enriched in the low water solubility component. When the reduced solubility for the small droplets achieved via addition of the secondary oil component balances the Kelvin effect, droplet growth ceases.

Davis and Wotton [4] and Meinert [5] have proposed various secondary fluorocarbons to stabilize fluorocarbon emulsions. Unfortunately, none of these compounds have a half-life of less than 4 weeks, the half-life deemed acceptable for single dose drugs in medical applications [6].

MATERIALS AND METHODS

Concentrated emulsions of perflubron (PFOB) and perfluorodecalin (FDC) containing varying amounts of a high molecular weight, low water solubility, lipophilic fluorocarbon, perfluorodecyl bromide (PFDB), were manufactured and placed on an accelerated stability program at 40 °C. All emulsions contained 4% w/v egg yolk phospholipid (EYP) as the stabilizing surfactant. Changes in emulsion particle size distributions were analyzed by photosedimentation (Horiba CAPA-700). Tissue distributions of a 90/10 w/w PFOB/PFDB emulsion were monitored in male and female Wistar rats following a single intravenous administration at a dose of 5.4 g PFC/kg. Tissues (liver, spleen) were collected at 3, 7, 14, 28, and 56 days postdosing and analyzed for bromine content by X-ray fluorescence spectroscopy.

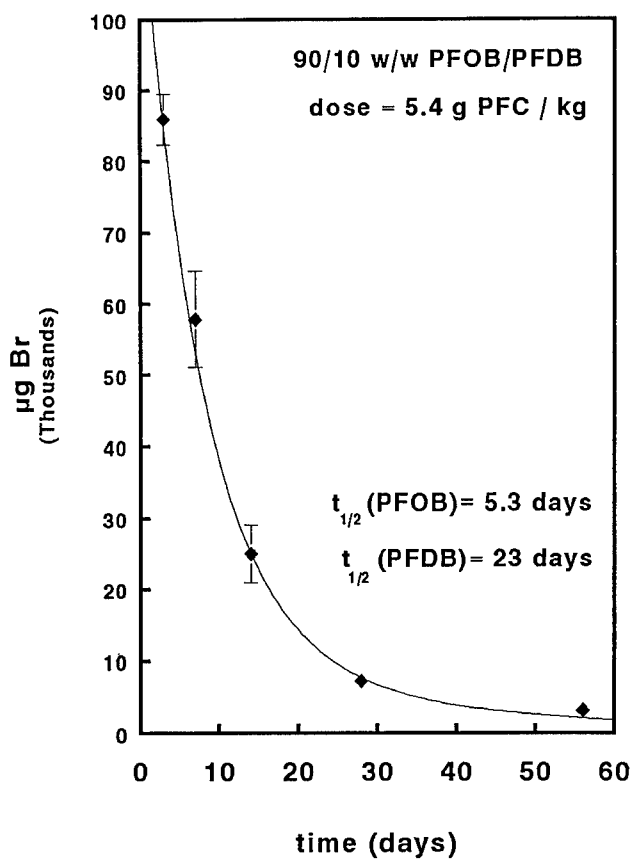

FIGURE 1. Total bromine in the RES vs. time for rats following intravenous administration of 5.4 g PFC/kg. The sample is a 90/10 w/w ratio of PFOB/PFDB.

RESULTS AND DISCUSSION

Half-Life in the RES. Figure 1 illustrates the total bromine content in the RES (liver + spleen) following intravenous infusion of a 90/10 w/w PFOB/PFDB emulsion at a dose of 5.4 g PFC/kg. Data shown are the means \pm SEM ($n = 8$ rats). A double exponential pharmacokinetic model (Minsq II, MicroMath Inc.) was used to fit the data. The initial and terminal half-lives of bromine were 5 and 23 days, respectively, presumably corresponding to the PFOB and PFDB components.

Figure 2 illustrates the RES half-life as a function of molecular weight for a diverse series of fluorocarbons. The small filled circles are data from Yamanouchi et al. [7]. Also included are specific emulsion stabilizers proposed to reduce Ostwald ripening. These include perfluoroperhydrophenanthrene (FPHP), proposed by Davis and Wotton, perfluorotripropylamine (FPA), the stabilizer used in Fluosol, and perfluoromethylcyclohexylpiperidine (PMCP), the stabilizer used in the Russian formulation, Perftoran. Also pictured (filled squares) are brominated fluorocarbons, including PFDB.

It is clear that there is a direct correlation between RES half-life and molecular weight. Based on this Riess [6] was able to define an optimal molecular weight range for blood substitutes between 460 and 560 g/mol. The lower limit requires that the fluorocarbon vapor pressure be below 20 torr at 37 °C, to ensure against the formation of pulmonary emboli. The upper value limits the RES half-life to less than four weeks. Notable exceptions to the general trend pictured are three lipophilic brominated fluorocarbons. Due to their increased lipophilicity, brought about by the presence of a terminal bromine atom, these molecules have much shorter half-lives than would be predicted for their molecular weight. Of particular interest as emulsion stabilizers are PFDB and $\text{CF}_3\text{CF}_2\text{CF}_2\text{O}(\text{CF}(\text{CF}_3)\text{CF}_2\text{O})_2\text{-CF}(\text{CF}_3)\text{Br}$ (PPEB) which have molecular weights greater than approximately 600 g/mol, and hence would be expected to have limited water solubility. PPEB has a reported half-life of 30 days (K. Makarov, personnel communication).

Emulsion Stabilization. Figure 3 presents droplet growth as a function of storage time at 40 °C for concentrated emulsions (90% w/v total fluorocarbon) containing pure PFOB or FDC, and mixtures with 10% w/w PFDB added. It is clear that addition of 10% w/w PFDB has a profound effect on emulsion stability. Whereas, control emulsions of FDC and PFOB have a particle size of ca. 0.5 μm after 3 months, emulsions containing 10% PFDB have sizes only slightly greater than their initial diameters, ca. 0.25 μm .

The effect of additive concentration on particle size distributions of concentrated PFOB emulsions (90% w/v total fluorocarbon, 4% w/v egg yolk phospholipid) is also depicted in Table I. Emulsions containing added PFDB have improved initial particle size distributions (following terminal sterilization). This is evidenced by improvements in median diameter, the width of the distribution (as noted by the standard deviation), and the percentage of large particles.

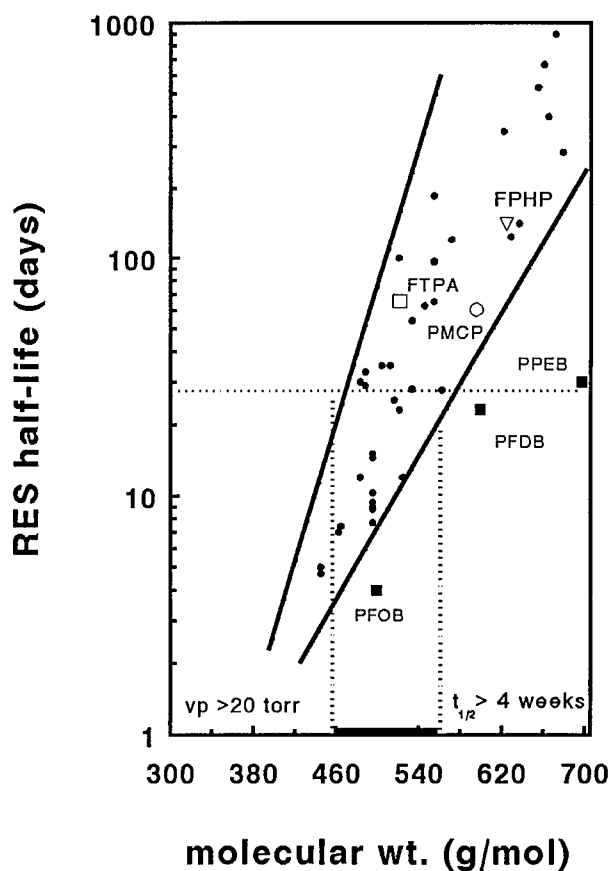

FIGURE 2. RES half-life vs. fluorocarbon molecular weight for a series of diverse fluorocarbons. Lipophilic fluorocarbons are observed to have shorter half-lives than would be predicted for their molecular weight.

With respect to the number of large droplets ($> 0.5 \mu\text{m}$), it is clear that their percentage decreases dramatically for emulsions containing PFDB, especially after three months of storage at 40°C . Whereas a control emulsion containing 90% w/v PFOB has ca. 50% of its droplets greater than $0.5 \mu\text{m}$ after 3 months at 40°C , an emulsion containing 5% w/w added PFDB has less than 10%.

Figure 4 illustrates the effect of PFDB concentration on emulsion growth rates for concentrated PFOB emulsions. The rate of particle growth (designated as "S"

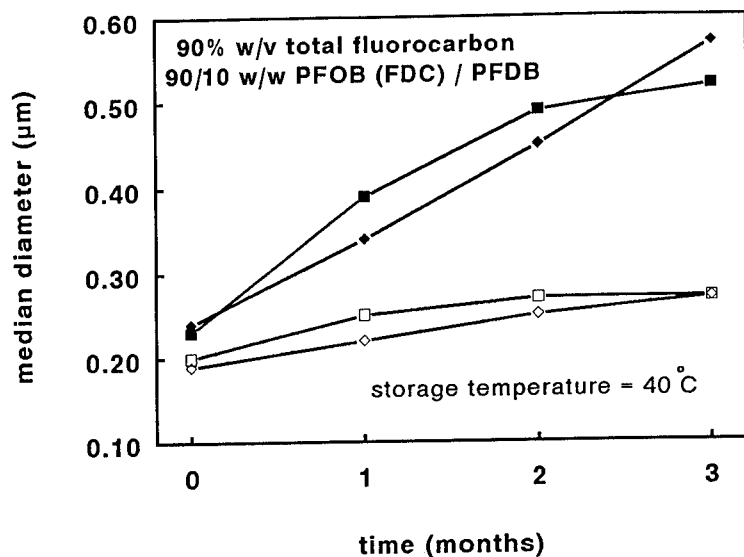

FIGURE 3. Median diameter vs. time for a series of concentrated (90% w/v) perfluorocarbon emulsions. The addition of 10% w/w PFDB to PFOB and FDC dramatically increases droplet stability. Squares and diamonds represent emulsions containing PFOB and FDC as the primary fluorocarbon respectively. Filled symbols represent control samples while the open symbols represent samples with 10% w/w added PFDB.

TABLE I. Effect of additive concentration on particle size distributions of concentrated perflubron emulsions (90% w/v total fluorocarbon, 4% w/v egg yolk phospholipid)

Property	Sample			
	0% PFDB	1% PFDB	2% PFDB	5% PFDB
		<i>initial</i>		
median diameter (μm)	0.23	0.23	0.19	0.18
standard deviation (μm)	0.13	0.12	0.09	0.08
% > 0.5 μm	6.3	5.2	2.4	1.4
		<i>t = 1 month at 40°C</i>		
median diameter (μm)	0.39	0.29	0.23	0.20
standard deviation (μm)	0.19	0.16	0.12	0.10
% > 0.5 μm	31.5	16.2	5.5	2.2
		<i>t = 2 months at 40°C</i>		
median diameter (μm)	0.49	0.37	0.26	0.24
standard deviation (μm)	0.20	0.19	0.14	0.13
% > 0.5 μm	48.0	16.2	9.2	5.3
		<i>t = 3 months at 40°C</i>		
median diameter (μm)	0.52	0.37	0.32	0.28
standard deviation (μm)	0.23	0.18	0.17	0.14
% > 0.5 μm	52.3	27.3	16.9	9.2
Sx1000 ($\mu\text{m}^3/\text{mo}$)	44.4	14.2	8.3	5.4

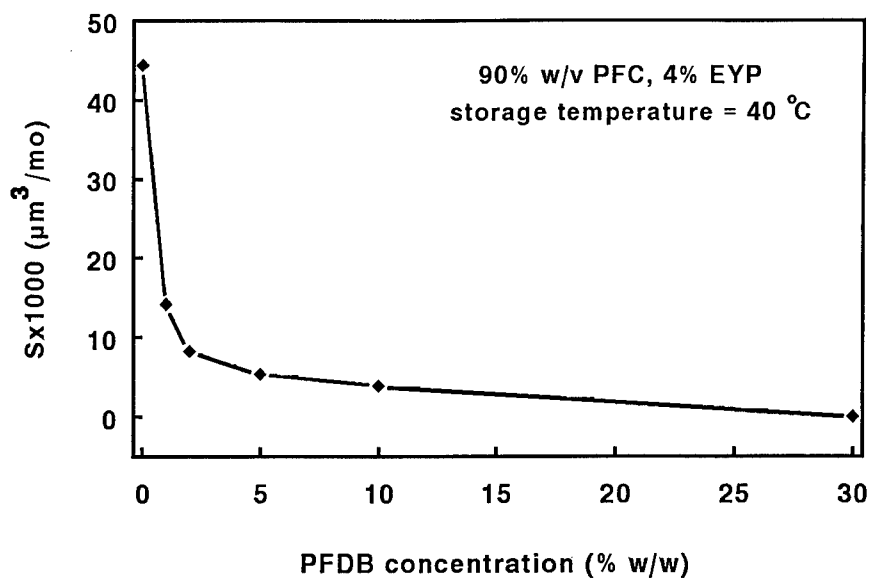

FIGURE 4. Growth rate vs. PFDB concentration in PFOB/PFDB mixtures. No droplet growth is observed for emulsions containing higher percentages of PFDB, indicating that room temperature stability is achievable.

in units of $\mu\text{m}^3/\text{mo}$) can be quantitated from linear plots of the diameter cubed vs. time. It is clear that at a storage temperature of 40 °C the growth rate begins to slow at concentrations as low as 5% w/w PFDB. At concentrations of 30% w/w PFDB no growth occurs at 40 °C over a 3 month period. Thus, extended room temperature stability is achievable with these formulations.

CONCLUSIONS

PFDB and other lipophilic fluorocarbons have RES half-lives much shorter than would be predicted by their molecular weight. This in combination with their reduced water solubility makes them well-suited as stabilizers to suppress Ostwald ripening in fluorocarbon emulsions destined as blood substitutes.

Although PFDB has been used as an example throughout this paper, it is readily apparent that any high molecular weight lipophilic fluorocarbon would suffice. For example, other halogenated or polyhalogenated fluorocarbons including

brominated ethers, or iodinated fluorocarbons may also work. Fluorocarbons terminated by short hydrocarbon fragments (e.g. $C_{10}F_{21}C_2H_5$ or $C_{10}F_{21}CH=CH_2$) may also be anticipated to have acceptable RES half-lives and promote enhanced emulsion stability.

REFERENCES

- [1] A.S. Kabalnov and E.D. Shchukin, *Adv. Coll. Interface Sci.* **38**, 69 (1992).
- [2] J.G. Riess In: *"Blood Substitutes and Oxygen Carriers"*, T.M.S. Chang, Ed.; M. Dekkar, New York, 1993, p. 24-43.
- [3] W.I. Higuchi and J. Misra, *J. Pharm. Sci.* **51**, 459 (1962).
- [4] S.S. Davis and E.M. Wotton, U.S. Patent No. 4,859,363 (1989).
- [5] H. Meinert, U.S. Patent No. 5,120,731 (1992).
- [6] J.G. Riess, *Artif. Organs* **8**, 44 (1984).
- [7] K. Yamanouchi et al., *Chem. Pharm. Bull.* **33**, 1221 (1985).

**IMPROVED CONTROL OVER PARTICLE SIZES AND STABILITY OF
CONCENTRATED FLUOROCARBON EMULSIONS
BY USING MIXED FLUOROCARBON/HYDROCARBON
MOLECULAR DOWELS**

C. Cornéus, M. P. Krafft and J. G. Riess.

Unité de Chimie Moléculaire associée au CNRS.

Faculté des Sciences

Université de Nice-Sophia Antipolis

06108 Nice cedex 2, France.

ABSTRACT: The use of a surfactant system consisting in equimolar amounts of egg yolk phospholipids and of a mixed fluorocarbon/hydrocarbon amphiphile ($C_8H_{17}CH=CHC_8F_{17}$) allows the preparation of concentrated (90% w/v, *i.e.* 47% v/v) emulsions of perfluorooctyl bromide (perflubron), with average particle sizes ranging from 0.12 to 16 μm post-sterilization, depending on the surfactant/fluorocarbon ratio. Emulsion droplet diameters varied linearly as a function of the emulsifier's concentration, thus allowing easy pre-determination of the emulsion's average particle size. Excellent stability was observed for the dowel-containing emulsions for at least 6 months at 40°C over the whole domain of particle sizes investigated.

INTRODUCTION

Oxygen-carrying fluorocarbon emulsions are being developed for a wide range of therapeutic applications [1,2]. Recent advances in the field brought to the foreground the need for fluorocarbon emulsions with physico-chemical and biological characteristics, including droplet sizes, that are more closely adapted to specific demands. Such flexibility is indeed required for the development of a third generation of fluorocarbon emulsions tailor-made for individual applications. A basic requirement is

that these emulsions display a shelf life compatible with transportation and long-term storage.

A major advance in terms of fluorocarbon emulsion stabilization has recently been achieved with the use of an emulsifying system consisting of an equimolar association of egg yolk phospholipids (EYP) with a mixed fluorocarbon/hydrocarbon amphiphile [3-5]. The latter plays the role of a molecular dowel between the phospholipids' fatty acid chain layer and the fluorocarbon droplet, thus improving the cohesion between the surfactant film and the fluorocarbon.

Our objective was to design and prepare efficacious, *i.e.* concentrated fluorocarbon emulsions which could be adjusted to have a wide range of particle sizes. These emulsions had also to be stable enough to retain their pre-selected size characteristics upon storage and transportation. It has been shown previously that the emulsions' stability depends on the phospholipids/fluorocarbon ratio [6] and, more recently, that the method used for dispersing the phospholipids in the aqueous phase also has a determinant effect on stability [7].

We now report the possibility of preparing stable concentrated (90% w/v, 47% v/v) and narrowly distributed emulsions of perfluorooctyl bromide (perflubron) with average particle sizes ranging from 0.12 to 16 μm , post-sterilization, depending on the amount of phospholipids and dowels used. Stability was assessed by means of particle size monitoring during accelerated ageing at 40°C for emulsions prepared both with and without the dowel molecule over the course of 6 months. The variation of the average droplet diameter in the dowel-stabilized emulsions as a function of the emulsifier's concentration was compared to the expected variation calculated on the basis of the phospholipid's molecular weight, its mean surface area occupied per molecule and the volume fraction of the fluorocarbon.

MATERIALS AND METHODS

Perfluorooctyl bromide ($\text{C}_8\text{F}_{17}\text{Br}$, perflubron) was supplied by Hoescht (Germany). The dowel molecule used, $\text{C}_8\text{H}_{17}\text{CH}=\text{CHC}_8\text{F}_{17}$ ($\text{F}_8\text{H}_8\text{E}$), was synthesized and purified in the Laboratory (98% purity, by GC) according to [8]. Injectable-grade egg yolk phospholipids (EYP, Lipoid 80) came from Lipoid KG (Germany).

The ingredients (see formulations below) were premixed using an Ultra-Turrax mixer model T25 (Ika-Labortechnik, Germany). Emulsification was achieved with a Microfluidizer model M110 (Microfluidics Corp. USA) fitted with a stainless steel cooling coil (diameter 0.12 in, length 1m), or with a Rannie Mini-Lab type 8.30H (APV Rannie, Denmark) using the ceramic cylinder configuration. Sterilization was achieved

under standard conditions (15 min, 121°C, 15 psi). The emulsions were then bottled in 15 mL-size vials, filled with argon and stored at 40°C for 6 months.

Average particle sizes and particle size distribution histograms were measured by photosedimentation (Horiba analyzer, model Capa-700, Japan) after preparation ($\pm 10\%$), after sterilization ($\pm 10\%$) and at regular intervals of time during ageing ($\pm 5\%$). It has been shown [6,9] that fluorocarbon/EYP emulsions generally contain a population of fluorocarbon-empty EYP vesicles in addition to the EYP-coated fluorocarbon droplets. Consequently, the average diameter of the fluorocarbon droplets measured by the photosedimentation technique was corrected by subtracting the contribution corresponding to these EYP vesicles [6].

Preparation of emulsions with particle sizes lower than 1 μm

The amount of phospholipids needed to obtain emulsions with particle sizes lower than 1 μm ranged from *ca* 0.4 to 8% w/v. All these emulsions were obtained using a Microfluidizer. The processing conditions are described below for a typical example : the C₈F₁₇Br/EYP/F₈H₈E (90/4/2.9% w/v) emulsion. The Rannie homogenizer can also be used for the preparation of such fine emulsions; slightly larger average particle sizes and broader distributions are, however, obtained.

Preparation of a C₈F₁₇Br/EYP/F₈H₈E 90/4/2.89% w/v emulsion (100 mL-size batch) : EYP (4g) was dispersed for 1 min under argon in 47.3 mL of a buffered aqueous solution (Na₂HPO₄. H₂O: 0.355% w/v, NaH₂PO₄. 7 H₂O : 0.052% w/v) with the Ultra-Turrax mixer at 8000 rpm, under argon, in a thermoregulated bath at 15°C. F₈H₈E (2.89g) was added in 1 min into the stirred phospholipid dispersion. Perflubron (90g, 46.9 mL) was added dropwise (20 mL/min) to the mixture, after which the mixing rate was increased to 24000 rpm for 10 min. The coarse premix was then run through the Microfluidizer and cycled 12 times through the interaction chambers under a pressure of 12000 psi, while the cooling bath was maintained at 30-35°C. The pH was measured to be 7.60 ± 0.05 before sterilization and 7.40 ± 0.05 after sterilization. All the operations were performed under argon to assure oxygen exclusion.

Reference emulsions which do not contain the dowel molecule were prepared using the same procedure.

Preparation of emulsions with particles ranging from ca 1 to 16 μm

The preparation of stable emulsions with average particle sizes larger than 1 μm was difficult with the Microfluidizer, as plugging of the interaction chambers occurred frequently. This inconvenience was not experienced with high pressure homogenization using the Rannie Mini-Lab device. A typical procedure is detailed below.

Preparation of a $C_8F_{17}Br/EYP/F_8H_8E$ 90/0.40/0.29% w/v emulsion (100 mL-size batch) : EYP (0.40g), the above described buffered solution (52.7g), F_8H_8E (0.29g), and perflubron (90g) were premixed as described above, under argon, at 15°C. The mixing rate was set at 8000 rpm, instead of 24000 rpm, for the last 10 minutes of premixing. The resulting premix was then run through the Rannie homogenizer for 3 min at 4000 psi under argon. The pH was measured to be 7.40 ± 0.05 before sterilization and 7.20 ± 0.05 after sterilization.

The reference emulsions, which do not contain the dowel molecule, were prepared in the same way.

RESULTS AND DISCUSSION

Preparation and stability characteristics of fluorocarbon emulsions with differently sized particles.

The preparation of a series of concentrated (90% w/v, 47% v/v) emulsions of perfluorooctyl bromide was achieved using equimolar mixtures of phospholipids (concentrations ranging from 0.05 to 8% w/v) and of the dowel molecule $C_8H_{17}CH=CHC_8F_{17}$ (F_8H_8E , from 0.036 to 5.8% w/v). These emulsions were heat-sterilized under standard conditions. A second series of emulsions, using phospholipids as the sole emulsifier in concentrations ranging from 0.05 to 8% w/v, were prepared and heat-sterilized under the same conditions.

Table I displays the average particle sizes, measured for the sterilized emulsions prepared both with and without the dowel molecule, for a series of formulations. It can be seen that the average particle size is essentially determined by the amount of surfactant. Droplet sizes increase, as expected, as the amount of surfactant diminishes.

The difference between the two series of emulsions is apparent when their stability is examined. The preparation of emulsions with average particle sizes larger than 3.4 μm (EYP 0.2%) was found to be impossible with phospholipids alone: the emulsions obtained with percentages of EYP lower than 0.2% undergo phase separation within minutes. On the other hand, the use of the molecular dowel allows the preparation of emulsions with very large average particle sizes (up to 16 μm) using EYP concentrations as low as 0.05% w/v. These emulsions are stable enough to allow their heat-sterilization under standard conditions. This result is consistent with the fact that mixed fluorocarbon/hydrocarbon dowels are held in the phospholipid membrane and reinforce its cohesion with the fluorocarbon phase.

TABLE I : Average particle sizes of freshly sterilized perflubron emulsions (90% w/v, 47% v/v) stabilized by egg yolk phospholipids alone or by an equimolar mixture of phospholipids and the mixed fluorocarbon/hydrocarbon amphiphile F8H8E.

EYP (%w/v)	F8H8E (%w/v)	Emulsions based on EYP alone av. particle size ($\mu\text{m} \pm 10\%$)	Emulsions based on EYP/F8H8E av. particle size ($\mu\text{m} \pm 10\%$)
8	5.8	0.12	0.12
4	2.89	0.19	0.17
2	1.45	0.25	0.25
1	0.72	0.36	0.36
0.7	0.51	0.56	0.54
0.4	0.29	1.22	1.12
0.3	0.22	2.2	1.9
0.2	0.14	3.4	2.9
0.17	0.12	- *	4.0
0.15	0.11	- *	4.5
0.1	0.072	- *	5.2
0.07	0.051	- *	9.9
0.05	0.036	- *	16

* The emulsions undergo phase separation within a few minutes.

Linear variation of emulsion droplet sizes as a function of surfactant concentration.

The experimentally measured average droplet diameters have been plotted on a log-log chart as a function of the inverse of phospholipid concentration for the dowel-containing emulsions after an initial annealing period of 20 days (Fig. 1). Some typical size distribution histograms, measured after the equilibration period, are inserted in Figure 1. After this period of equilibration, which is a well-known phenomenon in liposome and emulsion technology, the emulsions stabilized by the molecular dowels were found to be stable over the course of several months over the whole range of sizes investigated (see below).

A linear variation of average droplet size as a function of surfactant concentration has been observed. This allows a pre-determination of the amount of surfactant needed to obtain a certain average droplet size. This ability is of clear value in research involving special requirements in terms of emulsion's characteristics.

The theoretical amount of phospholipids necessary to emulsify a given volume of fluorocarbon to yield a given droplet radius can be calculated, assuming that the

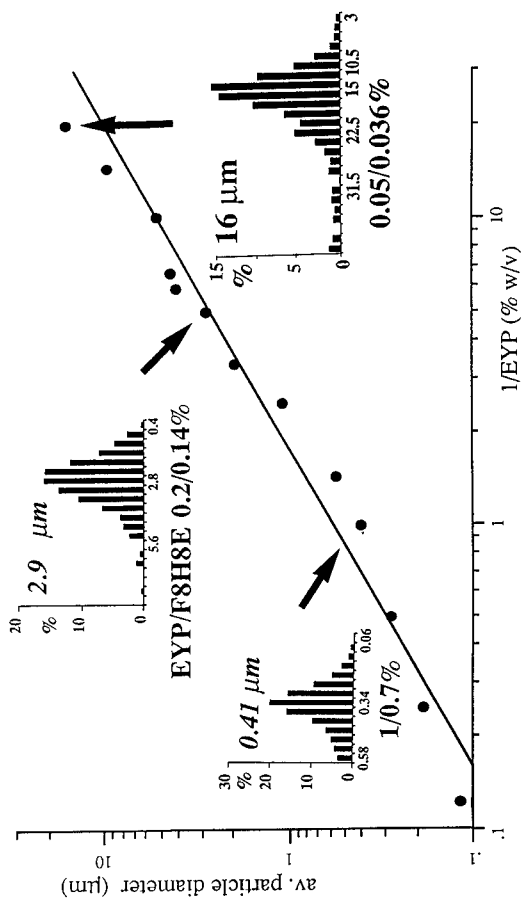

FIGURE 1: Linear variation of average particle sizes in sterilized 90% w/v emulsions of perfluorooctyl bromide stabilized by molecular dowels (F8H8E). A good fit is obtained between the calculated variation (—) and the experimental data (●). Av. particle sizes and size distribution histograms were measured after a 20-day annealing period.

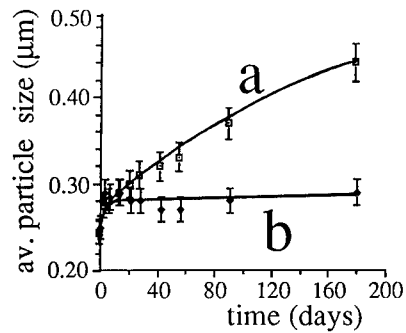

FIGURE 2: Ageing of a concentrated (90% w/v) perflubron emulsion prepared with a) phospholipids alone (2% w/v) and b) an equimolar EYP/F8H8E mixture (2/1.45% w/v)

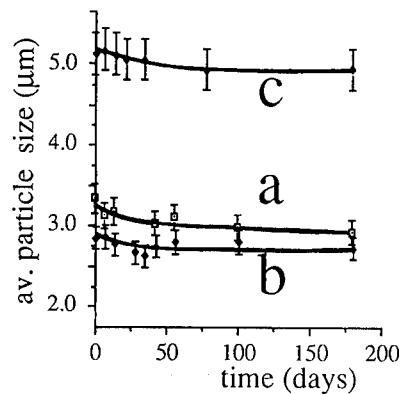

FIGURE 3: Ageing of concentrated (90% w/v) perflubron emulsions prepared with a) EYP alone (0.2% w/v) and b) and c) two different EYP/F8H8E mixtures (b: 0.2/0.14% w/v; c: 0.1/0.07% w/v). No stable emulsion could be prepared with only 0.1% of EYP.

fluorocarbon droplets are surrounded by a monolayer of phospholipids. This theoretical concentration of EYP is a linear function of the inverse of the droplet radius (r):

$[EYP] = C/r$, where C is a constant which includes the average molecular weight of the phospholipids (*ca* 760), the mean surface area occupied by a phospholipid molecule (*ca* 50 Å) and the volume fraction of fluorocarbon (47% v/v). Figure 1 shows that a good agreement is observed between the calculated and experimental results.

Emulsions stability upon ageing

The perfluorooctyl bromide emulsions containing from 0.05 to 8% w/v EYP and the molecular dowel, as well as the reference emulsions containing EYP alone, were stored for stability studies at 40°C for a period of 6 months. For the domain of droplet sizes ranging from *ca* 0.1 to 1 μm the dowel-based emulsions are considerably more stable than the reference emulsions. In the typical example shown in Figure 2 there is no significant variation in average sizes during the six-months period after the initial annealing period. Under the same conditions, the reference emulsions prepared without the dowel-molecule undergo a two-fold increase in particle sizes.

For emulsions with particle sizes larger than 1 μm , neither the emulsions prepared with the dowel molecule nor those prepared without, show any significant variation of their average particle size (Fig. 3).

For EYP-based emulsions, as particle sizes become larger, the rate of particle size increase during ageing progressively slows down. This is in agreement with the generally accepted emulsion coarsening mechanism, i.e. molecular diffusion or Ostwald ripening, according to which the rate of increase is proportional to the size of the fluorocarbon droplet: molecular diffusion becomes negligible when particles are larger than *ca* 1 μm . The fact that the incorporation of minute amounts of the dowel molecule allows the preparation of stable emulsions with very large particle sizes, i.e. emulsions in which molecular diffusion is no longer an effective emulsion degradation mechanism, infers that the dowel molecule is present as a co-surfactant in the lipid membrane rather than dispersed throughout the fluorocarbon phase [10].

ACKNOWLEDGEMENTS: We wish to thank the Centre National de la Recherche Scientifique and Applications et Transferts de Technologies Avancées (C. C.) for their support.

REFERENCES

- [1] J.G. Riess, *Vox Sanguinis*, **61**, 225 (1991).
- [2] J.G. Riess, *Biomat., Art. Cells, Immob. Biotech.*, **20**, 183 (1992).
- [3] J.G. Riess, M. Postel, *Biomat., Art. Cells, Immob. Biotech.*, **20**, 819 (1992).
- [4] J.G. Riess, L. Sole-Violan, M. Postel, *J. Disp. Sci. Technol.* **13**, 349 (1992).
- [5] J.G. Riess, C. Cornelus, R. Follana, M. P. Krafft, A. M. Mahé, M. Postel, L. Zarif, in "*Oxygen Transport to Tissues XV*" P. Vaupel (ed), Plenum Publ. Corp. New York (in press).
- [6] M.P. Krafft, J.P. Rolland, J.G. Riess, *J. Phys. Chem.*, **95**, 5673 (1991).
- [7] C. Cornelus, M.P. Krafft, F. Giulieri, J. G. Riess, *Colloid Surf.*, **XXX** (1993)

- [8] G. V. D. Tiers, *J. Org. Chem.*, **27**, 2261 (1962).
N. O. Brace, *J. Org. Chem.*, **37**, 2429 (1972).
- [9] M. Postel, P. Chang, J.P. Rolland, M.P. Krafft, J.G. Riess, *Biochim. Biophys. Acta*, **1086**, 95 (1991).
- [10] C. Cornelus, M.P. Krafft, J. G. Riess (unpublished results).

**BIODISTRIBUTION AND EXCRETION OF A MIXED
FLUOROCARBON-HYDROCARBON "DOWEL" EMULSION
AS DETERMINED BY ^{19}F NMR.**

Zarif, L.¹, Postel, M.¹, Trevino, L.¹, Riess, J.G.¹, Valla, A.²,
Follana, R.²

¹*Unité de Chimie Moléculaire, associée au CNRS, Université de Nice-
Sophia Antipolis, Parc Valrose, 06108 Nice cedex 02, France ;*

²*Centre Départemental de Transfusion Sanguine, Avenue Dr. M. Donat,
06700 St Laurent du Var, France.*

ABSTRACT

To investigate the biodistribution, possible metabolism and excretion of mixed fluorocarbon-hydrocarbon "dowel" molecules used as stabilizers of fluorocarbon emulsions, we have prepared a 25% w/v emulsion of such a molecule, and quantitatively evaluated, by means of ^{19}F NMR, its behavior in the blood and reticuloendothelial system (RES) of rats. $\text{C}_6\text{F}_{13}\text{CH}=\text{CHC}_{10}\text{H}_{21}$ (F6H10E) was emulsified using egg yolk phospholipids (EYP). The emulsion (F6H10E/EYP : 25/6 %w/v) was injected intravenously into 33 Sprague Dawley female rats at a 3.6 g/kg body weight dose of F6H10E. The animals were sacrificed at regular intervals of time. 24 hours after the injection, 70% of the injected dose was located in the liver, 17 % in the spleen, 4 % in the lungs, 2 % in the kidneys and 2 % in the blood. The half-time retention of the dowel molecule in the liver was estimated to be 25 ± 5 days. None of the 33 treated animals died prior to the planned sacrifice date. The dowel molecule F6H10E proved to be well tolerated, and excreted reasonably fast, without metabolism. This appears to warrant the use of such

molecules as stabilizers in injectable fluorocarbon emulsions destined to serve as oxygen carriers, contrast agents or drug delivery systems.

INTRODUCTION

The development of fluorocarbon-based oxygen carriers has experienced decisive progress over the past few years [1-3]. Fluosol[®] (Green Cross Corp., Osaka, Japan) has been approved for use during percutaneous transluminal coronary angioplasty for high risks patients. Second generation of emulsions, such as Oxygent[™] (Alliance Pharmaceutical Corp. San Diego, USA), which are four to five times more concentrated, have considerably improved the O₂-delivery efficacy of the emulsions [4, 5]. The latter emulsions are also much more stable ; contrary to Fluosol, they are ready to use and can be stored unfrozen. Further efforts are being devoted to developing emulsions with long term room temperature stability in order to fully exploit the therapeutic benefits of fluorocarbons.

Remarkable stabilization of concentrated (90% by weight, 47% by volume) fluorocarbon emulsions formulated with egg-yolk phospholipids (EYP) has been achieved by adding small amounts (typically 0.1 to 3% by weight) of a mixed fluorocarbon-hydrocarbon R_FR_H amphiphile such as C₆F₁₃CH=CHC₁₀H₂₁ (F6H10E). These mixed fluorocarbon/hydrocarbon amphiphiles act as molecular "dowels" to reinforce the binding between the fluorocarbon droplets and the lipidic EYP membrane which surrounds them. The incorporation of such a R_FR_H dowel molecule to 90% w/v concentrated emulsions of perfluorooctyl bromide, C₈F₁₇Br (perflubron) or of bis(F-butyl)ethene, C₄F₉CH=CHC₄F₉ (F-44E) was shown to result in easier emulsification, smaller initial median droplet sizes, narrower particle size distributions and close to complete suppression of particle growth at room temperature or even at 40°C. Similar stabilization effects have been obtained with saturated dowel molecules such as C₆F₁₃C₁₀H₂₁ (F6H10) [6, 7].

In order to evaluate the distribution in the organs and the excretion rate of a typical mixed fluorocarbon-hydrocarbon compound, F6H10E was formulated as a 25% (w/v) emulsion with EYP (6% w/v) as the emulsifier. The latter was used because of its wide acceptance in pharmaceuticals, including concentrated fluorocarbon emulsions, liposomes and lipid emulsions for parenteral nutrition [1,2,8]. This F6H10E emulsion was injected intravenously into female rats at a 3.6 g/Kg body weight dose. Such a dose represents *ca* 600 times the amount needed to

stabilize a clinically relevant dose of a concentrated fluorocarbon emulsion with small (*ca* 0.2 μm) particles sizes [7].

We describe herein the distribution of the typical "dowel" molecule F6H10E in the organs as determined by ^{19}F NMR spectroscopy at various time points. This technique has already been successfully used for analyzing biological samples for exogeneous fluorinated compounds [9-11].

MATERIALS AND METHODS

F6H10E was prepared according to the literature [12]. Its purity (> 99 %) was checked by gas chromatography. Final purification, prior to use, included : (i) washing with 10% w/v KOH and water for injection, followed by filtration over Whatman N°1 SP filter paper, and (ii) treatment with activated carbon (neutralized Sigma C-5385 ; 1g/100 ml of product) and filtration over a short Al_2O_3 (70-230 mesh, Merck Inc.) column. EYP came from Asahi.

Emulsion : A 25 % w/v F6H10E emulsion was prepared as follows :

EYP (19.8g) was added under argon to an isotonic phosphate buffer solution. The mixture was dispersed with an Ultra Tumax mixer at 8000 rpm for 60s. F6H10E (82.8 g) was then added at a rate of ~ 20 ml/min. The rate of mixing was then increased to 14000 rpm for an additional 20 min. The resulting premix was emulsified with a microfluidizer (110M, 12 passes, 10,000 psi, Ar atmosphere, 25-30°C). The emulsion was then sterilized in 12 ml vials (121°, 15 min, 15 psi). Emulsion particle size was assessed by photosedimentation (Horiba capa 700).

Animals : OFA Sprague Dawley female rats (~ 200 g) were anesthetized and injected via the jugular vein with a 15 ml/kg of F6H10E emulsion (3.6 g/kg bw of neat F6H10E) at a rate of 1 ml/min. The animals were sacrificed at 2, 4, 8, 24 and 48 hours, 4, 10, 15 and 21 days, 1, 2.5, 3 and 4 months (3 animals per point). Blood and organs were removed, weighed and frozen immediately. Comparison was made with a series of control animal who received the same dose of physiological water.

^{19}F NMR measurements : Known quantities of organ and water were ground using an Ultra Turrax mixer at 20°C. A sample (0.25 ml) of this mixture was added to 0.25 ml of a $\text{CF}_3\text{CH}_2\text{OH}$ solution of known concentration used as an internal

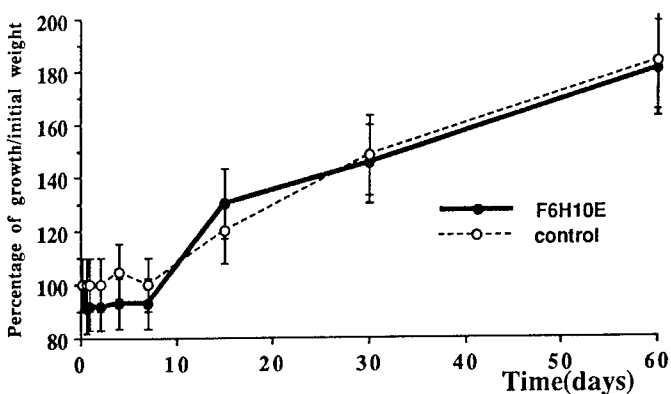

FIGURE 1 : Comparison between the growth of the animals which had received F6H10E emulsion (15 ml/kg bw, n=3) and the controls (15 ml/kg bw of 0.9 % NaCl, n=3)

standard. The 5 mm NMR tube was vortexed for 1 min and ^{19}F spectra recorded immediately. The ^{19}F NMR measurements were conducted at 188.3 MHz (Bruker A-200 spectrometer). $\text{CF}_3\text{CH}_2\text{OH}$ was used as an internal standard (-77ppm upfield from CFCl_3); the assay consisted of integrating the surface areas covered by the terminal CF_3 signals of the internal standard and of the F6H10E. The percentage of F6H10E remaining in the organs was thus determined ($\pm 10\%$).

RESULTS AND DISCUSSION

Long term growth of the animals who received the F6H10E emulsion was comparable to that of the control. However, a loss of weight ($< 10\%$) was noted during the first few days after the experimental injection (Figure 1).

^{19}F NMR allowed the determination of the biodistribution and of the rate of elimination of the dowel molecule. It also indicated the absence of F6H10E metabolites in the analyzed organs (limit of detection, 10^{-4} M) (Figure 2).

Most of the injected F6H10E emulsion was taken up by the liver and spleen, 70 % and 17 % respectively after 24h. These results are in line with the usual elimination behavior of emulsified fluorocarbon [12-13]. A minimal quantity of material was found in the lungs and kidneys (4 and 2 % after 24h, respectively) (Figure 3). The half-life of F6H10E in the liver was estimated to 25 ± 5 days.

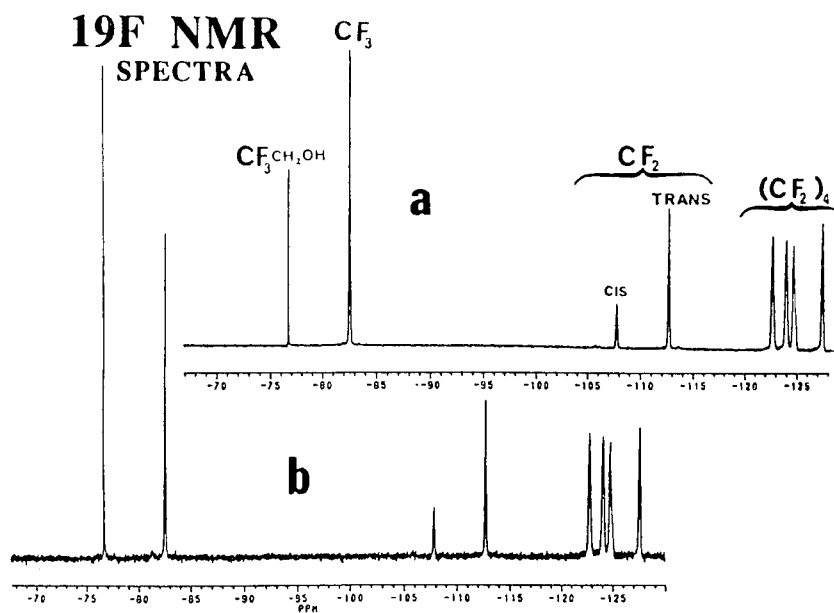

FIGURE 2 : A typical ¹⁹F NMR spectra of F6H10E a) in a F6H10E emulsion before administration b) in homogenized rat liver 15 days after its administration

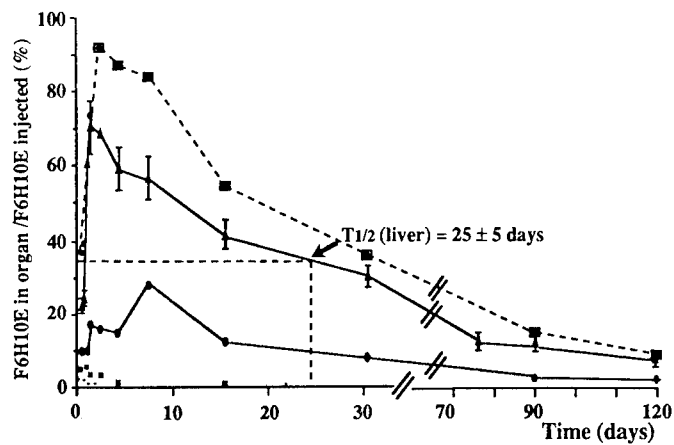

FIGURE 3 : F6H10E concentration in the animals'organs (liver ▲ , spleen ■ , kidneys •) as a function of time.

In conclusion, the dowel molecule investigated appears to be well tolerated in high doses, excreted reasonably rapidly, and metabolically inert. These findings, combined with the remarkable stabilization these compounds confer on fluorocarbon emulsions, offer much promise for their utilization in future fluorocarbon emulsion formulations. The absence of metabolism should greatly simplify their pharmacology/toxicology evaluation.

Acknowledgments : We thank the Centre National de la Recherche Scientifique, Applications et Transferts de Technologies Avancées (LZ) and Alliance Pharmaceutical Corp. (LT) for financial support.

REFERENCES

- [1] J. G. Riess, *Biomat., Art. Cells., Immob. Biotech.*, **20**, 183-204 (1992).
- [2] J.G. Riess, *Vox Sang.*, **61**, 225-239 (1991)
- [3] N.S. Faithfull, *Biomat., Art. Cells., Immob. Biotech.*, **20**, 797-804 (1992).
- [4] D.C. Long, D.M. Long, J.G. Riess, R. Follana, A. Burgan, R.F. Mattrey, in "*Blood Substitutes*" T.M.S. Chang, R.P. Geyer (eds) , Marcel Dekker, New York, 441-442 (1989).
- [5] J.G. Riess, J.L. Dalfors, G.K. Hanna, D.H. Klein, M.P. Krafft, T.J. Pelura, E.G. Schutt, *Biomat, Art. Cells, Immob. Biotech*, **20**, 839-842 (1992).
- [6] J.G. Riess, M. Postel, *Biomat., Art. Cells, Immob. Biotech.*, **20**, 819-830 (1992).
- [7] J. G. Riess, L. Solé Violan, M. Postel, *J. Disp. Sci. and Technol.*, **13**, 349-355 (1992).
- [8] a) G. Gregoriadis : "*Liposomes as Drug Carriers. Recent Trends and Progress*", Wiley, Chichester, 1988. b) A. Wretling, "*Fat Emulsions in Parenteral Nutrition*" H.C. Meng, and D.W. Wilmore (eds), p. 109-122 (1976).
- [9] M.C. Malet-Martino, D. Betbeder, A. Lattes, A. Lopez, R. Martino, G. Francois, S. Cros, *J. Pharm. Pharmacol.*, **36**, 556-559 (1984).
- [10] P.S. Tofts , S. Wray, *NMR in Biomedicine*, **1**, 1-10 (1988).
- [11] J.G. Riess, C. Cornelus, M.P. Krafft, A.M. Mahé, M. Postel, L. Zarif, in "*Oxygen Transport to Tissues XV*" P. Vaupel (ed), Plenum Publ. Corp, New York (in press).
- [12] N. O. Brace, *J. Org. Chem.*, **37**, 2429-2433 (1972).
- [13] Y. Tsuda, K. Yamanouchi, K. Yokoyama, T. Suyama, in "*Blood Substitutes*", T.M.S. Chang, R.P. Geyer (eds) Marcel Dekker, New York, p. 473-483 (1988).

PULMONARY GAS TRAPPING DIFFERENCES AMONG ANIMAL SPECIES IN RESPONSE TO INTRAVENOUS INFUSION OF PERFLUOROCARBON EMULSIONS

T. Leakakos, E.G. Schutt, J.C. Cavin, D. Smith, J.D. Bradley, C.A. Strnat,
U. del Balzo, D.Y. Hazard, S. Otto, T.K. Fields, P.E. Keipert,
D.H. Klein, and S.F. Flaim
Alliance Pharmaceutical Corp., San Diego, CA 92121

ABSTRACT

In animals, increased lung volume and a concomitant failure of lungs to collapse normally upon autopsy can occur following intravenous injection of higher vapor pressure perfluorocarbons (PFCs) administered as emulsions. Responses vary considerably depending on the PFC, dose and animal model. The study objective was to examine animal species differences with respect to this apparent pulmonary gas trapping (PGT) phenomenon which has not been observed in human clinical trials. A dose-related increase in postmortem lung volume following treatment with either a concentrated perflubron emulsion or *Fluosol*[®] was observed. It was most pronounced in pigs, rabbits and monkeys, and essentially nonexistent in mice and dogs. No clear effects on arterial blood gases were seen in most species, but PaO₂ levels were reduced transiently in monkeys given the highest PFC doses. Reversibility of pulmonary effects occurred more rapidly with perflubron emulsions than with *Fluosol*. Vacuolated mononuclear cells, reflecting the presence of PFC particles in the lung, and alveolar distention varied between species, but no lesions or edema were observed. Species differences in collateral ventilation, airway morphology and pulmonary intravascular macrophages may influence their sensitivity and contribute to the interspecies differences in response to intravenously administered PFC emulsions.

INTRODUCTION

The objective of these studies was to examine pulmonary effects in different animal species following intravenous (i.v.) administration of PFC emulsions. Equivalent doses of

two different PFC emulsions were used. A perflubron emulsion (90% w/v perfluorooctyl bromide) was studied whose therapeutic value includes imaging and oxygen carrying abilities [1,2,3]. Also studied was *Fluosol*, a 20% w/v PFC emulsion containing 14% w/v perfluorodecalin and 6% w/v perfluorotripropylamine, which is currently approved as an oxygen delivery agent for use during percutaneous transluminal coronary angioplasty.

PHARMACOKINETIC ASPECTS OF PFC EMULSIONS

The lung is the main route of elimination following i.v. administration of PFC emulsions. Perflubron elimination in rats treated with 3 mL/kg perflubron emulsion showed most of the PFC to be expired by 28 days postdosing. There is no evidence of metabolism of PFCs prior to elimination. Gas chromatography/mass spectrometry analysis of liver samples from rats injected with perflubron emulsion conclusively demonstrated no metabolic changes in the PFC. The blood half-life of perflubron emulsions is dose-dependent and ranges from a few hours in rats, dogs and pigs to more than 3 times longer in rabbits at equal doses. PFC emulsion droplets are cleared from the blood primarily by the reticuloendothelial system (RES). The rate of PFC elimination from the RES is related to both its vapor pressure and lipophilicity. The RES elimination half-life of perflubron is 4 days compared to 7 and 65 days for perfluorodecalin and perfluorotripropylamine respectively.

PULMONARY EFFECTS

An increase in lung volume at necropsy has been seen in certain animal species following i.v. administration of perflubron emulsion or *Fluosol*. Lung volume measurements in rabbits 7 days after treatment with 3 mL [2.7 g perflubron]/kg perflubron emulsion or 15 mL [3.0 g PFC]/kg *Fluosol* showed an increase in functional residual capacity from 3.4 ± 1.0 mL/kg for saline controls to 4.0 ± 1.4 mL/kg for perflubron and 16.0 ± 4.0 mL/kg for *Fluosol*. Vital capacity was unchanged between control and perflubron groups, but decreased in the *Fluosol*-treated animals. Thoracic gas volume was also increased in rabbits treated with either of the 2 PFC emulsions. Transthoracic pressure-volume curves were similar between saline controls and perflubron-treated animals, but there was an obvious decrease in lung compliance in the *Fluosol* group. The dose-dependent increase in lung volume and the reversibility of lung volume and PaO₂ changes can be seen in Figure 1 where monkeys were treated with two different doses of perflubron emulsion. Microscopic evaluation of treated lungs showed subtle, transient effects that consisted primarily of a mild increase in mononuclear cell number along with

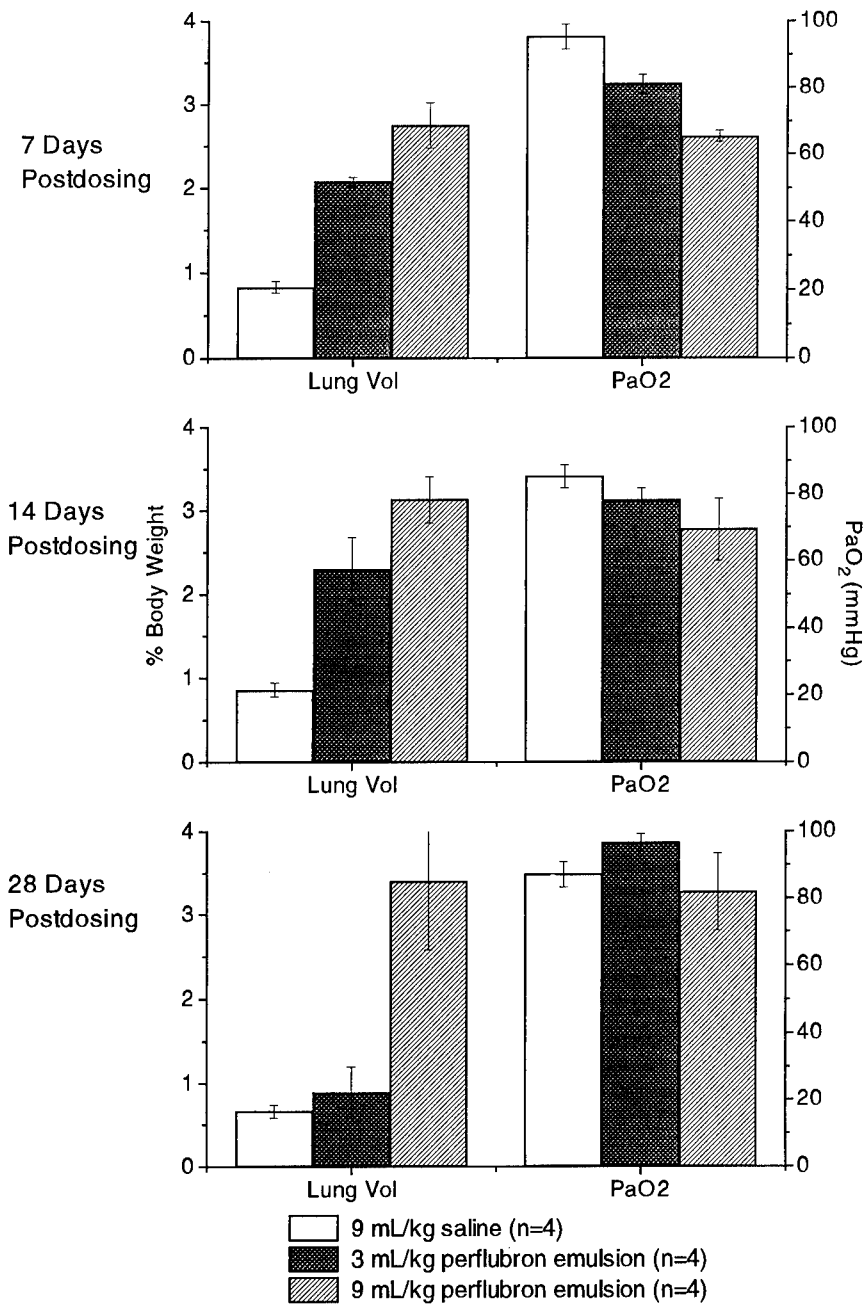

FIGURE 1. Lung volumes and PaO₂ levels in cynomolgus monkeys at 7, 14 and 28 days after intravenous administration of perflubron emulsion. Values represent mean ± SE.

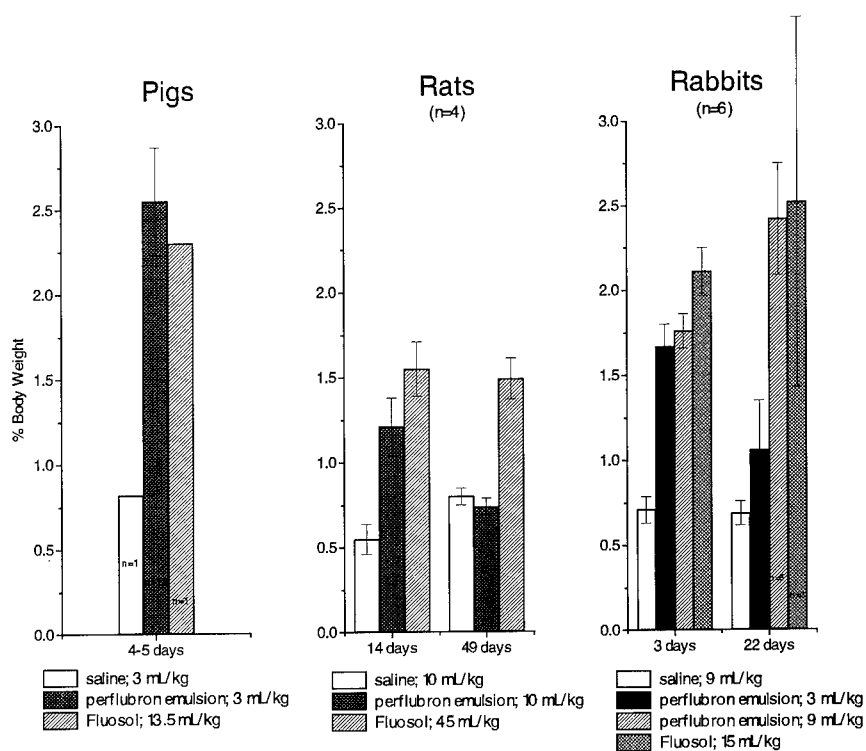

FIGURE 2. Lung volumes in 3 species following treatment with PFC emulsions. Lung volumes expressed as a percentage of body weight in pigs are shown 4-5 days after dosing with 3 mL/kg perflubron emulsion or 13.5 mL/kg *Fluosol* (pigs). Lung volumes in rats are shown 14 and 49 days after injection of a 10 mL/kg dose of perflubron emulsion or a 45 mL/kg dose of *Fluosol* (rats). Rabbit lung volumes are shown 3 and 22 days after dosing with 3 and 9 mL/kg perflubron emulsion and 15 mL/kg *Fluosol* (rabbits).

slight alveolar distention. The presence of vacuolated alveolar macrophages were indicative of PFC particles in the lung. No evidence of interstitial pulmonary edema was observed.

SPECIES COMPARISON

Pulmonary effect differences between species were evident with intravenous PFC emulsions (Fig. 2). Pigs were the most sensitive exhibiting the greatest increase in lung volumes at equivalent doses of 3 mL [2.7 g perflubron]/kg perflubron emulsion and 13.5 mL [2.7 g PFC]/kg *Fluosol*. Pigs are unique in possessing a large number of pulmonary

intravascular macrophages which may contribute to this increased lung sensitivity [4]. At similar doses, smaller but significant increases in lung volume occurred in rabbits and monkeys. Even smaller increases were seen with higher doses in rats. In rats, reversibility of the pulmonary effect occurred over time with perflubron emulsion, but not with *Fluosol*. Lung volumes increased in rabbits in a dose-related manner and reversibility was demonstrated only with perflubron emulsion. Changes in lung volume and function have not been observed in dogs treated with multiple doses of perflubron emulsion up to 12 mL/kg. Little or no pulmonary effect has been observed in mice [5,6]. In addition, no evidence of this phenomenon has been observed in humans.

CONCLUSION

There are a number of potentially important factors which may contribute to the different species responses to i.v. PFC emulsions. Collateral ventilation differences include the existence of many interalveolar connections and airway communications in dogs and humans which other species lack by comparison [7]. Sensitivity to PFC emulsions may be increased by the many pulmonary intravascular macrophages in pigs and the susceptibility of rabbits to pulmonary emphysema [8]. Substantially lower transpulmonary pressures in rabbits and monkeys may be a determinant of sensitivity to PFC emulsions in species which are unable to generate high tidal pressure swings [9]. Overall airway geometry differences should also be considered in explaining pulmonary responses. The larger lung volumes and increased dimensions of major airways in dogs and humans would not be conducive to a tendency to trap gas in the lungs.

REFERENCES

1. J.G. Riess. Fluorocarbon-based *in vivo* oxygen transport and delivery systems. *Vox Sang.* 61, 225-239, (1991).
2. J.G. Riess. Overview on progress in the fluorocarbon approach to *in vivo* oxygen delivery. In: *Blood Substitutes and oxygen carriers*, T.M.S. Chang (ed.), M. Dekker, New York, 24-43, (1993).
3. N.S. Faithfull. Oxygen delivery from fluorocarbon emulsions - Aspects of convective and diffusive transport. In: *Blood substitutes and oxygen carriers*, T.M.S. Chang (ed.), M. Dekker, New York, 569-576, (1993).
4. G.C. Winkler. Pulmonary intravascular macrophages in domestic animal species: review of structural and functional properties. *Am J Anat.* 181: 217-234 (1988).
5. L.C. Clark, F. Becattini and S. Kaplan. Can fluorocarbon emulsions be used as artificial blood? *Triangle* 11: 115-122 (1972).

6. A.R. Burgan, W.C. Herrick, D.M. Long and D.C. Long. Acute and subacute toxicity of 100% PFOB emulsion. *Biomat. Art. Cells Art. Org* 16: 681-682 (1988).
7. C.D. Port, K.V. Ketels, D.L. Coffin, and P. Kane. A comparative study of experimental and spontaneous emphysema. *J Toxicol Environ Health* 2: 589-604 (1977).
8. H.T.G. Strawbridge. Chronic pulmonary emphysema (an experimental study). II. Spontaneous pulmonary emphysema in rabbits. *Am J Pathol* 37: 309-331 (1960).
9. M.L. Crosfill and J.G. Widdicombe. Physical characteristics of the chest and lungs and the work of breathing in different mammalian species. *J Physiol* 158: 1-14 (1961).

PROPOSED MECHANISM OF PULMONARY GAS TRAPPING (PGT)
FOLLOWING INTRAVENOUS PERFLUOROCARBON EMULSION
ADMINISTRATION

E. Schutt, P. Barber, T. Fields, S. Flaim, J. Horodniak, P. Keipert, R. Kinner,
L. Kornbrust, T. Leakakos, T. Pelura, J. Weers, *R. Houmes, *B. Lachmann
Alliance Pharmaceutical Corp., 3040 Science Park Road, San Diego, CA 92121
*Erasmus University, Department of Anesthesiology, P.O. Box 1738, 3000 DR
Rotterdam, The Netherlands

ABSTRACT

Purpose: To investigate various hypotheses and identify the most likely mechanism preventing the complete collapse of test animal lungs at sacrifice subsequent to intravenous injection of certain perfluorocarbon emulsions.

Protocol: Literature data were reviewed, experimental data were extracted from completed studies and new data were generated in an attempt to delineate reasons why, in certain animals, lungs fail to collapse normally at necropsy if previously injected with certain perfluorocarbon emulsions. The proposed hypothesis involved gas osmosis through endogenous pulmonary surfactant-liquid bridges (micro-bubbles).

Results: The observed effect of incomplete lung collapse upon necropsy was found to correlate with perfluorocarbon vapor pressure. Results indicated that failure to collapse could be attributed to the formation of intra-alveolar micro-bubbles induced by the normal pulmonary elimination of perfluorocarbon vapor. These micro-bubbles result in a phenomenon which could be characterized by the term, pulmonary gas trapping. Reduction of the perfluorocarbon concentration gradient across the bubble films by exposure to a perfluorocarbon

vapor-containing atmosphere was found to reduce the effect in-vivo and prevent gas osmosis bubble growth in-vitro.

Conclusion: Experimental observations are consistent with the proposed theory of perfluorocarbon-related gas osmosis through micro-bubbles that prevent complete lung collapse as observed upon opening the thoracic cavity of test animals.

INTRODUCTION

It has been observed that the lungs of several animal species, that have been intravenously injected with certain perfluorocarbon (PFC) emulsions, do not fully deflate when the thoracic cavity is opened during necropsy [1,2]. Wide species differences have been observed, with dogs showing little or no effect while rabbits are very susceptible. Significant histological changes have not been observed; however, the alveoli of effected lungs appear inflated with gas, hence the term Pulmonary Gas Trapping (PGT) has been used to describe this condition. The PGT effect in rabbits injected with perflubron emulsions (3 ml/kg, 90% emulsion dose) [3] peaks at approximately 3 days and significantly resolves in approximately 3 weeks. Lung volumes larger than four times controls have been observed. The trapping of gas in lungs during ventilation of animals with other gases that slowly diffuse through liquid films and bubbles has been reported by D. G. Frazer [4].

RESULTS AND DISCUSSION

The proposed mechanism involves gas osmosis through naturally occurring liquid films, i.e., alveolar micro-bubbles. The existence of these bubbles has been reported by E. M. Scarpelli [5]. We propose that a normal rabbit lung generates small numbers of surfactant-coated liquid bridges (bubble films) during normal breathing. These bubbles normally slowly collapse as their film surface tension raises their internal pressure, which enhances gas diffusion out of the bubble (Figure 1). After injection of a PFC emulsion, the PFC leaves the body by diffusion from the circulatory system to the alveolar wall and vaporizes. PFC vapors dilute the gases inside alveolar bubbles, reducing the diffusion rate of gases out of the bubble while the diffusion rate into the bubble remains unchanged thus causing the bubbles to grow slowly rather than shrink

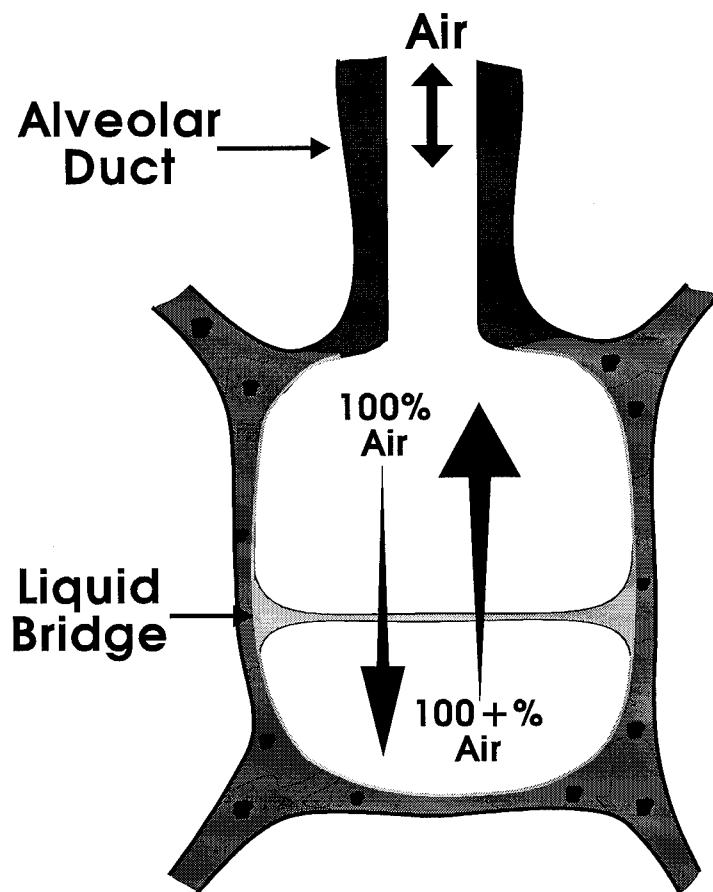

FIGURE 1. Normal alveolus gas diffusion with liquid bridge collapsing.

(Figure 2). The PFC vapors are nearly insoluble in the protein free fluid in the bubble film and have a relatively high molecular weight (low diffusion constant) and thus leave the bubble very slowly. This effect is analogous to the osmotic inflation of a sugar-containing dialysis bag when immersed in distilled water, hence the term gas osmosis. The concentrations of PFC vapors are very low (tenths of a % by volume) but are significant relative to the low surface tension

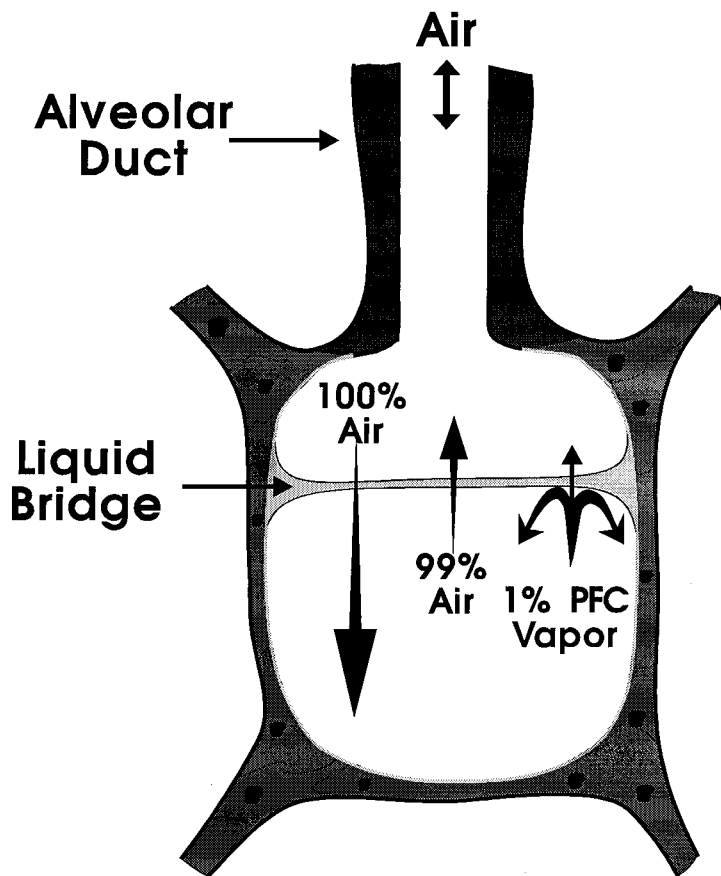

FIGURE 2. PFC vapor induced gas osmosis causes liquid bridge to grow.

of lung surfactant. These stabilized films are divided into micro-bubbles by the action of breathing (Figure 3) which keeps the alveoli inflated when the chest cavity is opened. They are likely to rupture easily during histological processing and are protein free, and thus, would not be visible with normal histological techniques. Nevertheless, on a number of occasions, foam has been noted in the airways of PGT animals during gross examination upon necropsy.

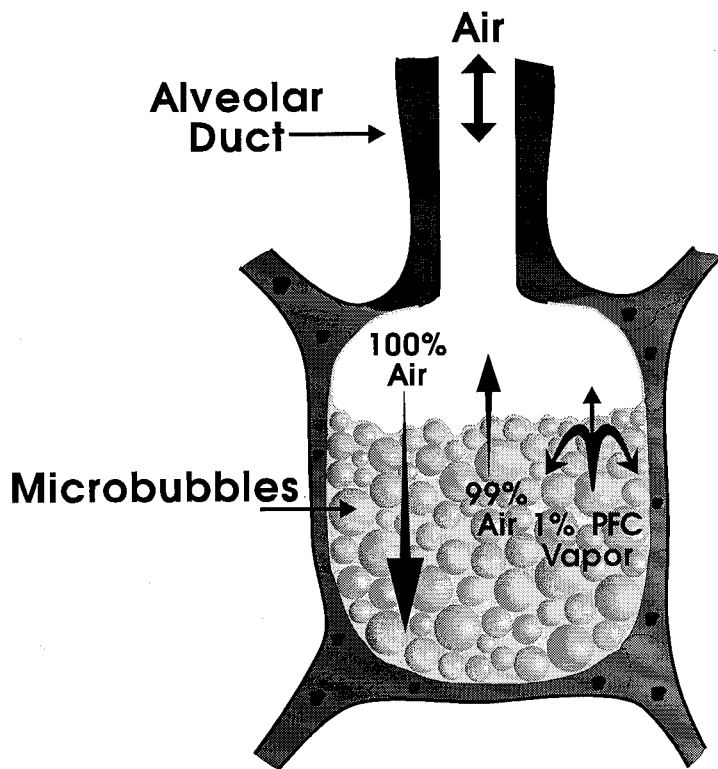

FIGURE 3. Respiratory cycling of liquid bridge into alveolar duct forms stabilized microbubbles.

Structural splinting (reduced tissue compliance) was considered but believed unlikely because significant structural changes have not been observed histologically; and cycling of excised PGT lungs to 2/3 atmosphere and back to one atmosphere causes venting of gasses through the trachea and complete reversal of PGT.

A strong dependence on perfluorocarbon vapor pressure was observed. Figure 4 depicts the percent gas volume increase in rabbit lungs (normalized for body weight at 6 days post dose) vs. vapor pressure at 37°C of the

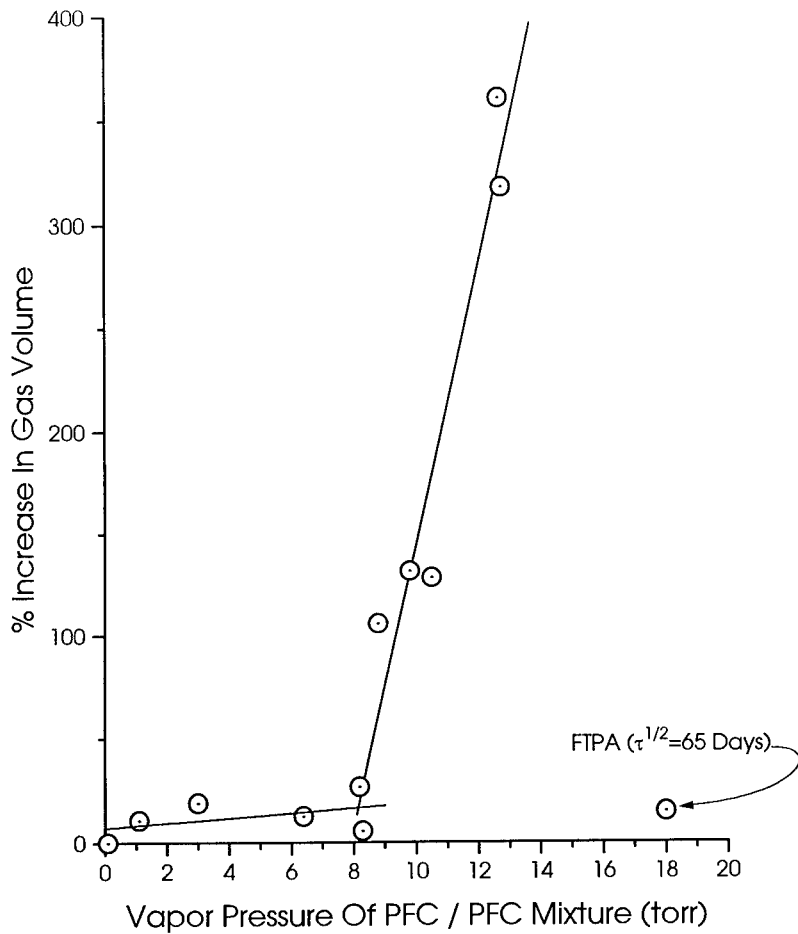

FIGURE 4. Effect of PFC vapor pressure on rabbit lung gas volume increase.

perfluorocarbons used to produce the injected emulsions. Perfluorocarbons with vapor pressures below approximately 8 torr produce little or no effect while those with higher vapor pressures produce increasing effects. Perfluorotripropylamine (VP = 18 torr at 37°C, lung gas volume increase = 29%) is an exception. A possible explanation might be that this perfluorocarbon (PFC) leaves the body slowly ($t^{1/2} = 65$ days) and thus produces lower PFC flux

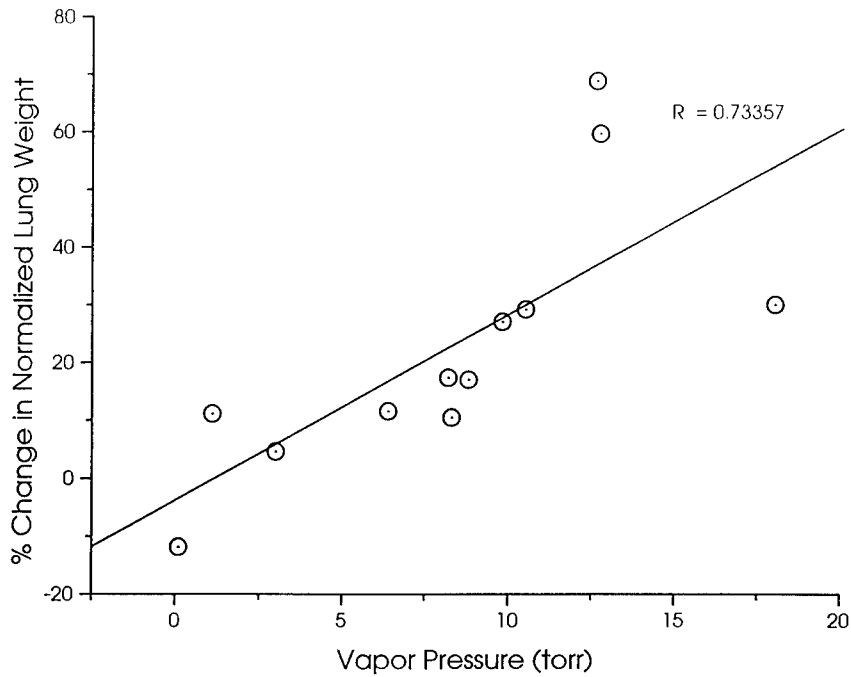

FIGURE 5. Rabbit lung weight vs. PFC/mixture vapor pressure.

rates in the lung than the other high vapor pressure PFCs tested. Figure 5 depicts normalized lung weight gain vs. vapor pressure for the same emulsions shown in Figure 4. No histological explanation was found for this weight gain (e.g., interstitial edema was not observed).

It has been observed that neat PFCs at the bottom of a tissue culture well containing an aqueous surfactant (e.g., SDS, serum or bovine lung surfactant) will generate small bubbles of air saturated with PFC, due to temperature change-induced outgassing, when placed at 37°C in a humidified incubator. These bubbles dramatically grow in diameter over the next 12 to 36 hours. PFCs with higher vapor pressures grow faster; those with sufficiently low vapor pressure do not grow perceptibly. Similar results were obtained with emulsions of these PFCs. Bubbles placed in an atmosphere previously saturated

Temperature change forms gas bubbles saturated with perflubron

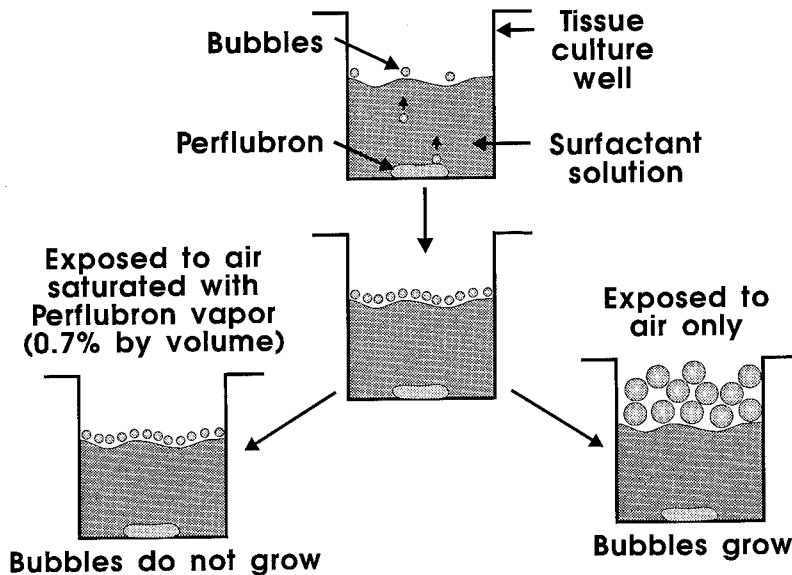

FIGURE 6. *In-vitro* gas osmosis.

with the same PFC used to generate the bubbles do not grow (Figure 6) thus indicating that a concentration gradient of PFC vapor across the bubble film drives the observed bubble growth, consistent with a gas osmosis mechanism.

An analogous experiment *in-vivo* was reported by L. C. Clark, Jr., *et.al.* [1]. Animals injected with an emulsion produced with a PFC that caused PGT were allowed to breathe air saturated with the same PFC's vapor. Clark noted that the PGT effect was prevented. Preliminary data from our experiments (Figure 7) indicate that perflubron emulsion-injected rabbits, breathing an atmosphere approximately 50% saturated with perflubron at 37°C, exhibited a reduced PGT effect (reduced lung volume) when compared to air breathing animals. This experiment is still in progress and while replicate numbers are low,

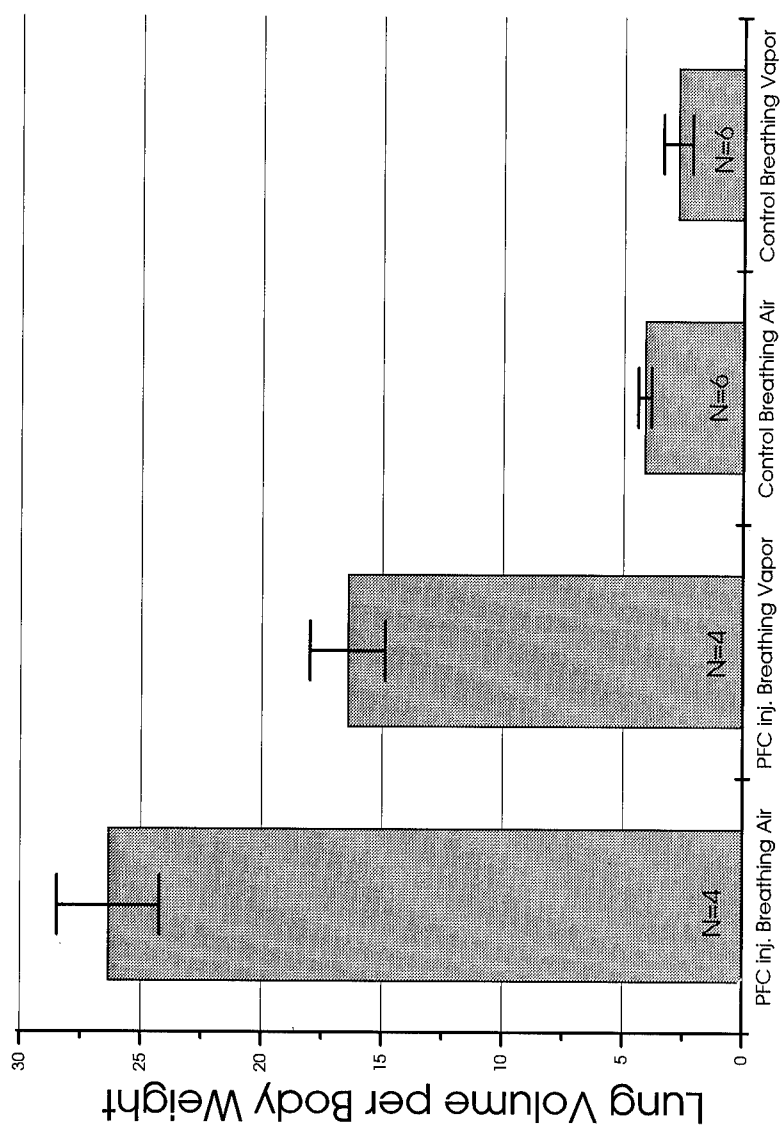

FIGURE 7. The effect of PFC vapors on rabbit PGT lung volume.

it confirms the trend reported by Clark. The breathing of PFC vapor would reduce the PFC vapor concentration gradient across bubble films in the lung while increasing the total animal exposure to PFC and inhibiting its excretion. This dependence on a lung PFC vapor concentration gradient as opposed to total PFC exposure supports the gas osmosis PGT mechanism theory. The observed reduction of lung volume in vapor-breathing animals that were not injected with emulsion might be explained by an increased rate of shrinkage of naturally occurring surfactant bridges due to the negative PFC vapor concentration gradient imposed on the lung.

CONCLUSION

The proposed mechanism for pulmonary gas trapping (PGT) through the stabilization and growth of micro-bubbles by gas osmosis, induced by pulmonary PFC vapor concentration gradients, is consistent with the presently available *in-vitro* and *in-vivo* data.

REFERENCES

- 1) L. C. Clark, Jr., R. E. Hoffmann, & S. L. Davis. "Response of the rabbit lung as a criterion of safety for perfluorocarbon breathing and blood substitutes." *Biomat., Art. Cells & Immob. Biotech.*, 20(2-4), 1085-1099 (1992).
- 2) S. F. Flaim, T. Leakakos, E. G. Schutt, J. C. Cavin, D. Smith, J. D. Bradley, C. A. Strnat, U. delBalzo, D. Y. Hazard, S. Otto, T. K. Fields, P. E. Keipert, & D. H. Klein. "Evaluation of animal species differences in response to intravenous infusion of perfluorocarbon emulsions." *These Proceedings*.
- 3) J. G. Riess, J. L. Dalfors, G. K. Hanna, D. H. Klein, M-P Krafft, T. J. Pelura, & E. G. Schutt. Development of Highly Fluid, Concentrated and Stable Fluorocarbon Emulsions for Diagnosis and Therapy. *Biomat., Art. Cells & Immob. Biotech.*, 20: 839-842 (1992).
- 4) D. G. Frazer, *Respiratory Physiol.*, 40; 323-333 (1980).
- 5) E. M. Scarpelli, Surfactants and the Lining of the Lung. The Johns Hopkins University Press, Baltimore and London.

**PHAGOCYTOSIS OF A FLUORESCENTLY LABELED
PERFLUBRON EMULSION BY A HUMAN
MONOCYTE CELL LINE**

D. J. Smith, E. S. Kornbrust and T. A. Lane*
Alliance Pharmaceutical Corporation, San Diego, CA 92121,
and *University of California, San Diego,
Department of Pathology, La Jolla, CA 92093

ABSTRACT

We hypothesized that fluorocarbon-based lipid emulsions are phagocytosed by monocytes and that many of the *in vivo* side effects related to the infusion of these particulate emulsions are due to release of cytokines by these monocytes. To clarify whether these emulsions are actually phagocytosed we attempted to measure by flow cytometry the apparent uptake of a fluorescently labeled high-concentration (90%, w/v) perflubron (perfluorooctyl bromide [PFOB]) emulsion by a differentiated human monocyte cell line.

A fluorescent chromophore (Zynaxis Cell Science) was used to label the egg yolk phospholipid in a perflubron emulsion. This phospholipid label was used to track the perflubron emulsion during overnight incubation with the human monocyte (THP-1) cell line which had been differentiated, by exposure to PMA, into macrophage-like cells.

Our results indicate that after 24 hours of incubation with the labeled perflubron emulsion, 64.9% (± 11.0) of differentiated THP-1 cells had cell-associated emulsion (ingested and/or membrane bound) whereas 24.4 (± 6.8 %) of the control cells had cell-associated emulsion. We speculate that this technique may be a useful method to track the intravascular persistence and extravascular distribution of such emulsions, and that the degree of uptake of the emulsion by macrophages in this assay may correlate with its *in vivo* half life.

INTRODUCTION

High concentration fluorocarbon-based lipid emulsions have been shown to be efficacious in delivery of oxygen to tissues and imaging diagnosis (1,2,3). We hypothesized that perfluorocarbon-based emulsions are phagocytosed by cells of the monocyte/macrophage lineage and that many of the in vivo side effects (i.e. fever, cutaneous flushing) related to the infusion of these particulate emulsions [4] are due to monocyte activation and release of cytokines by monocytic cells which have phagocytosed the emulsion.

To clarify whether these emulsions are actually phagocytosed we attempted to measure by flow cytometry the apparent uptake of a fluorescently labeled high-concentration (90%, w/v) perflubron emulsion by a PMA-differentiated human mononuclear cell line (THP-1 cells) or control cells which had been pre-treated with cytochalasin-B.

An aliphatic, fluorescent chromophore (Zynaxis Cell Science) which has previously been used for in vivo and in vitro viable cell tracking [5] was used to label the egg yolk phospholipid of a perflubron emulsion. This phospholipid label was used to track the perflubron emulsion during incubation with the human monocyte (THP-1) cell line which had been differentiated, by exposure to PMA, into macrophage-like cells.

MATERIALS AND METHODS

Emulsion Labeling: One ml of a 90% perflubron/egg yolk phospholipid emulsion was washed by centrifugation, three times with sterile phosphate buffered saline (PBS). A PKH 26-GL Cell Linker Kit was obtained from Zynaxis Cell Science (Malvern, PA). The kit's PKH 26 dye was diluted to 4×10^{-6} molar with the provided diluent-C just prior to use. The washed perflubron emulsion volume was brought back to 1 ml with diluent-C. One ml of diluted PKH 26 dye was added to 1 ml of the washed perflubron emulsion, mixed gently and incubated 5 minutes at room temperature. The reaction was stopped by washing again with sterile PBS 4 times as above. The labeled emulsion was used in the assay within 5 days from labeling, but has been shown to be stable on viable cells for over a month [5,6].

THP-1 Cell Differentiation: The THP-1 human acute monocytic leukemia cell line [7] was obtained from the American Type Culture Collection, (Rockville Maryland) and maintained in endotoxin-free RPMI 1640 supplemented with 10% fetal calf serum,

10mM hepes, 2mM glutamine, pen/strep (100U/ml ,100µg/ml respectively) and 10µM β-mercaptoethanol. Differentiation [8] was accomplished by diluting the THP-1's to 5×10^5 cells/ml and adding 10µM phorbol-12, myristate-13, acetate (PMA) to the cells just prior to plating 1 ml per well into sterile 24 well cell culture plates. The THP-1 cells were allowed to differentiate into adherent macrophage-like cells for 4 days. Media on top of the cells was gently replaced with fresh media 2 hours prior to cell use in assay.

Assay of Differentiated THP-1 Cell Phagocytosis: Differentiated THP-1 cells were incubated 24 hours at 37°C in a 5% CO₂ humidified atmosphere in the presence of the fluorescence labeled perflubron emulsion. Differentiated THP-1 cells which had been pre-treated with cytochalasin-B (10µg/ml) were used as control cells with paralyzed phagocytic ability [9] to determine the extent of macrophage cell-associated binding versus actual phagocytosis of the emulsion by the THP-1 cells. At multiple time points during the incubation, subsets of the THP-1's were gently washed free of excess emulsion, isolated and assayed for the presence of the fluorescent perflubron emulsion by flow cytometry. An Ortho Cytofluorograph flow cytometer was used to analyze the samples with an excitation wavelength of 488nm filter from an argon laser and emission spectra was analyzed with a 570nm band pass filter. The fluorescent measurements were gated on forward versus 90° angle light scatter to eliminate any non-cell-associated fluorescence. Both the amount of labeled emulsion per THP-1 cell and the percent of THP-1 cells which had ingested the emulsion were quantitated.

RESULTS

We were successful in fluorescently labeling the egg yolk phospholipid of a 90% (w/v) perflubron emulsion and tracking its uptake by the differentiated human monocytic THP-1 cell line. This process was unique in that it appears to be the first time that a phospholipid emulsion, and not a viable cell source, has been labeled with this dye.

Figure 1 illustrates the ingestion of the labeled emulsion with time by the THP-1 cells compared to control THP-1 cells of limited phagocytic ability. As incubation time proceeds the amount of labeled emulsion phagocytosed by THP-1 cells increases substantially compared to the cytochalasin-B control cells which have only cell-association capability. Assuming that a similar percent of non-cytochalasin-B treated

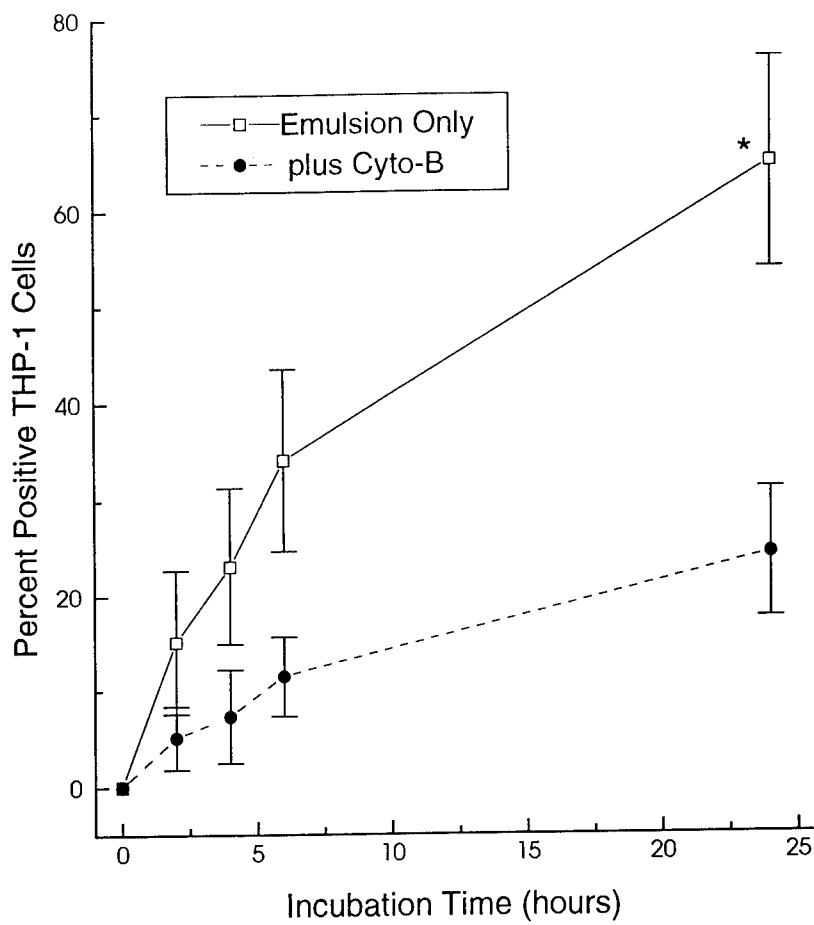

FIGURE 1. Percent fluorescence-positive THP-1 cells with and without cytochalasin-B present. As incubation time increases the amount of labeled emulsion phagocytosed by THP-1 cells increases dramatically compared to the cytochalasin-B control cells which have only cell-association capability. Data points represent mean \pm standard error of the mean (SEM) of 3 replicate experiments. (*) Indicates significant difference ($p < 0.05$) from control.

THP-1 cells would have had the labeled emulsion only externally associated with the cells, almost three times as much emulsion was phagocytized as was only cell-associated with the control cells ($64.9 \pm 11.0\%$ compared to $24.4 \pm 6.8\%$) after 24 hours incubation.

While the number of THP-1 cells which ingest the emulsion increased with time, the amount of emulsion phagocytosed per THP-1 cell also increases per cell compared to control, cytochalasin-B treated THP-1 cells (Figure 2).

DISCUSSION

Our results indicate that a) the uptake of perflubron emulsion by macrophages can be quantitated by the use of a fluorescent label attached to the emulsion, and b) after 24 hours of incubation with the labeled perflubron emulsion, almost 3 times the number of non-treated differentiated THP-1 cells had cell-associated emulsion (ingested and/or membrane bound) compared to control (cytochalasin-B treated) THP-1 cells. Tsuchiya et.al. [8] found differentiated THP-1 cells to become macrophage-like with the ability to readily phagocytose yeast, sheep red blood cells (SRBC) and IgG-coated SRBC's compared to non-differentiated THP-1's. The results presented here confirm the differentiated THP-1 cell's ability to also rapidly ingest the labeled perflubron emulsion compared to cytochalasin-B treated control cells which appear to only show cell association of the emulsion in the form of external attachment to the THP-1 cells. Cytochalasin-B is known to paralyze phagocytosis along with cytokinesis and locomotion by preventing changes in the state of actin polymerization [9].

Microspheres and liposomes have been shown to stimulate the arachidonic acid cascade, principally thromboxane A_2 , after intravenous administration and macrophage phagocytosis in pigs [10] and sheep [11], respectively. We hypothesized that perfluorocarbon-based emulsions may induce in vivo side effects (fever, cutaneous flushing) via interaction with macrophages which are stimulated to release cytokines. The in vitro assay described here may mimic phagocytosis of this emulsion by macrophages in vivo. We speculate that this technique may be a useful method in tracking the intravascular persistence and extravascular distribution of such emulsions, and that the degree of uptake of the emulsion by macrophages in this assay may correlate with its in vivo half life. Finally, if the extent of phagocytosis correlates with cytokine release, this technique may serve as a useful method for optimizing such emulsions for in vivo use.

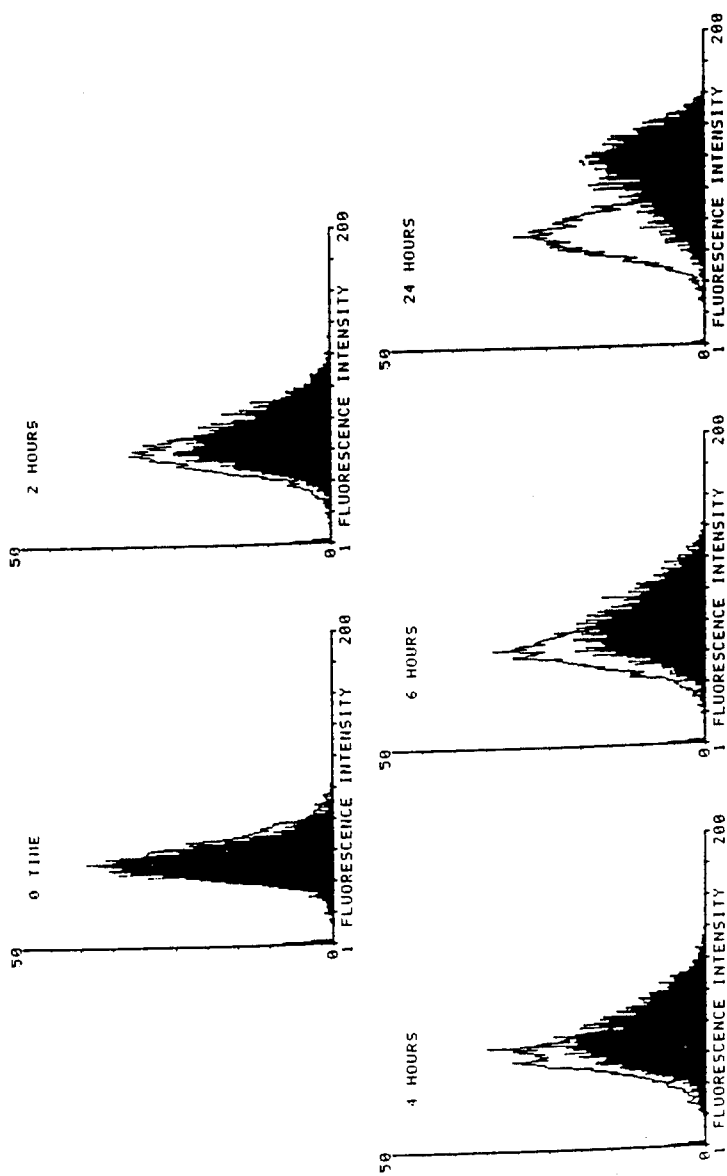

FIGURE 2. Increase in mean fluorescent intensity and the percentage of labeled-emulsion incubated THP-1 cells without cytochalasin-B present (solid) compared to a similar incubation with cytochalasin-B present (outline). Abscissa (Y axis) represents cell count. This series of time-elapsd plots illustrates the increase in the fluorescent intensity of the THP-1 cells as they ingest the labeled perflubron emulsion relative to the control cytochalasin-B cells in a typical experiment. The labeled emulsion is injected by more THP-1 cells and more emulsion particles are injected per cell as the incubation time continues.

REFERENCES:

1. JG Riess, JL Dalfors, GK Hanna, DH Klein, M-P Kraft, TJ Pelura, EG Schutt. Development of Highly Fluid, Concentrated and Stable Fluorocarbon Emulsions for Diagnosis and Therapy. *Biomat., Art. Cells and Immob. Biotech.* 20: 839-42 (1992)
2. JG Riess. Overview on Progress in the Fluorocarbon Approach to in vivo Oxygen Delivery. 183-204 (1992)
3. NS Faithfull. Oxygen Delivery from Fluorocarbon Emulsions- Aspects of Convective and Diffusive Transport. *Biomat., Art. Cells and Immob. Biotech.* 20: 797-804 (1992)
4. SF Flaim, DR Hazard, J Hogan and RM Peters. Characterization and Mechanism of Side-effects of Oxygen HT (High Concentration Fluorocarbon Emulsion) in Swine. *Biomat., Art. Cells and Immob. Biotech.* 19:383 (1991)
5. BD Jensen, TC Schmitt, SE Slezak. Labeling of Mammalian Cells for In Vivo Cell Tracking by a Fluorescent method; *Prog Clin Biol Res*, 355:199-207 (1990)
6. PK Horan, SE Slezak. Stable Cell Membrane Labeling; *Nature* 340: (6229):167-8 (1989)
7. S Tsuchiya, M Yamabe, Y Yamaguchi, Y Kobayashi, T Konno, K Tada. Establishment and Characterization of a Human Acute Monocytic Leukemia Cell Line (THP-1); *Int. J. Cancer*: 26, 171-6 (1980)
8. S Tsuchiya, Y Kobayashi, Y Goto, H Okumura, S Nakae, T Konno, K Tada. Induction of Maturation in Cultured Human Monocytic Leukemia Cells by a Phorbol Diester; *Cancer Res*, 42:1530-6 (1982)
9. B Alberts. The Cytoskeleton. *In: The Cell*, pp. 642. New York & London: Garland Publishing, Inc. (1989).
10. J Ostensen, R Hede, TE Myreng, E Holtz. Intravenous Injection of Alburnex Microspheres causes Thromboxane Mediated Pulmonary Hypertension in Pigs, but not Monkeys or Rabbits; *Acta Physiologica Scand*, 144: 307-15, (1992)
11. K Miyamoto, E Schultz, T Heath, MD Mitchell, KH Albertine, NC Staub. Pulmonary Intravascular Macrophages and Hemodynamic Effects of Liposomes in Sheep; *J. Appl Physiol.* 64(3): 1143-52 (1988)

INFLUENCE OF PERFLUBRON ON THE CREATION OF OXYGEN FREE
RADICAL PRODUCTS IN MESENTERIC ARTERY OCCLUSION SHOCK

A.J. Augustin and J. Lutz

Dept. of Physiology, University of Wuerzburg, Roentgenring 9, Wuerzburg, Germany

ABSTRACT

The influence of a temporary occlusion of the superior mesentery artery on the generation of oxygen free radical products was tested in controls and after administration of perflubron. The occlusion time lasted for 90 min and a reperfusion time of 150 min was chosen until examination of tissue samples took place. The content of thiobarbituric acid reactive substances (TBARS), glutathione (GSH) and myeloperoxidase (MPO) was determined in homogenized tissue samples. A protective effect of antioxidants or radical scavengers was tested in form of α -tocopherol and allopurinol.

A highly significant increase of TBARS was found in the operated control group, still higher under perflubron (perfluorooctylbromide, PFOB). However, under α -tocopherol as well as under allopurinol the effect of radical products could be diminished below the values of controls. GSH and MPO were not significantly changed under PFOB as compared to the operated control group.

INTRODUCTION

Transient mesenteric artery occlusion (MAO) and the following reperfusion period were found by our group to create an increase in lipid peroxides of more than 20 fold, expressed by the amount of TBARS [1-6]. The content of reduced glutathione decreases significantly, whereas the activity of myeloperoxidase rises. Thus this preparation can serve as a reliable model for the generation of oxygen free radical products.

Treatment with artificial oxygen carriers under increased oxygen partial pressure might result in the generation of additional oxygen free radicals [7].

We therefore tested the question whether additionally generated oxygen free radicals would arise from treatment with PFOB and if so, how it could be compensated by an additive treatment with antioxidants or radical scavengers.

MATERIALS AND METHODS

All tests were done with male rats of Wistar strain of 250-350 g body weight. They were kept on standard diet (Altromin, Lage, FRG) and had access to food and water ad libitum until the beginning of the experiments. The animals were randomly divided in groups of four and housed in macrolon cages.

One group (1) served as control and was untreated. The other groups (2-5) underwent reversible occlusion of the superior mesenteric artery under ether anesthesia. This was done by pulling the prepared vessel by means of a thread against a PE-90 tube which was lead through the abdominal wall. The external portion of the thread was fixed at the tube until removal. Following surgery and still under ether anesthesia an analgesic (tramadol, 2.5 mg/kg body weight) was given and repeated at the reopening of the vessel. This occurred 90 min after the beginning of occlusion. Immediately before the vessel was reopened by loosening the thread, three experimental groups (3-5) received PFOB in form of OxygentTMHT [8] (90% w/v, Alliance Pharmaceutical Corp., San Diego CA) in a dose of 3 g/kg b.wt., one group (2) remained without agents. One of the experimental groups (4) had been additionally treated with α -tocopherol 100 mg/kg s.c. on two previous days, another (5) received 100 mg/kg b.wt. of allopurinol together with the PFOB injection i.v.. Allopurinol was given not only as xanthine oxidase inhibitor, but also as a potent hydroxyl radical scavenger. In the following reperfusion period, which lasted 150 min, all operated groups were transferred into a plastic tent surrounding their cages to breath oxygen with a FiO_2 -0.9 for the duration of the reperfusion period. After the reperfusion period the animals were killed by exsanguination under ether anesthesia.

In homogenized tissue samples of the gut of all animals the content of TBARS was determined according to a modification of the method of Ohkawa et al. [9]. Amounts of 0,1,2, and 3 nmol of tetramethoxypropane served as external standard and were assayed in the above described way. All determinations were performed in duplicate.

Additionally, values of TBARS were controlled by high performance liquid chromatography (HPLC) of malondialdehyde-like substances [10].

As a further test for oxidative stress the content of glutathione in the reduced (GSH) and oxidized (GSSG) form was determined according to the method described by Tietze [11] in a modification of Griffith [12]. Besides determination of total glutathione concentration with glutathione reductase, GSSG was estimated in parallel samples after neutralization of the extract and derivatization of GSH in the presence of 2-vinylpyridine. Standards were made up in 2% 5-sulfosalicylic acid. GSH and GSSG gave the same standard curves when expressed on the basis of GSH equivalents.

The tissue level of myeloperoxidase (MPO) was determined according to Krawisz et al. [13]. The specimens (200-500 mg) were homogenized for 30 sec (three times) in 3 ml hexadecyltrimethylammoniumbromide (HTBA) solution (0.5% HTBA in 50 mM phosphate buffer, pH 6.0) with an Ultra Turrax^(R) blender. HTBA acts in releasing MPO from the primary granules of the neutrophils. The homogenate was sonicated for 10 sec, freeze-thawed three times and centrifuged at 40000 g for 15 min at 4° C. The supernatant was assayed for myeloperoxidase activity spectrophotometrically; the change in absorbance at 460 nm was measured with a Shimadzu UV-190 spectrophotometer.

Statistical evaluation: The values are reported as means \pm SEM. One way analysis of variance (ANOVA) was utilized to determine whether there were statistically significant differences between the groups. Fisher's least significant differences test was used to identify those groups which accounted for the significant F-test. A $p < 0.05$ was considered to indicate significance.

RESULTS

Compared to the unoperated control group (1) with a TBARS level of 75.2 ± 19.9 nmol/g, the amount of TBARS increased after ischemia and reperfusion to 2095.6 ± 150.0 in group 2 ($p < 0.002$, Fig.1). Under PFOB the increase was enhanced to 2842.6 ± 311.8 nmol/g in group 3 ($p < 0.05$ against control group). Either α -tocopherol (in group 4) or allopurinol (in group 5) combined with PFOB succeeded in depression of the elevated TBARS values below those of the PFC free group: the respective values were 771.7 ± 83.0 and 700.5 ± 313.6 nmol/g (both $p < 0.02$ against group 2). A comparison of TBARS with HPLC-derived values of malondialde-

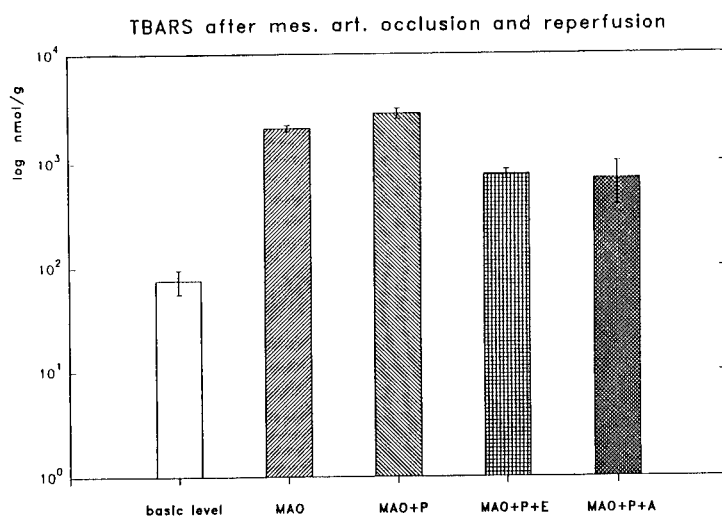

FIGURE 1. The content of TBARS in intestinal tissue of the tested groups. Each group consisted of at least 4, the first two groups of 8 animals. Significance of differences see text. MAO = mes.art.occl.; P = PFOB treatment; E = 2 x 100 mg/kg treatment with α -tocopherol s.c.; A = treatment with allopurinol 100 mg/kg i.v. Significance of differences is given in the text.

hyde-like substances resulted in a correlation factor of 0.9099, though TBARS were higher by a factor of 2.24.

GSH decreased highly significantly in group 2 from a control level of 2.76 ± 0.12 to 0.807 ± 0.07 mmol/g ($p < 0.001$, Fig.2). With PFOB no further decrease was found (group 3: 0.803 ± 0.04 mmol/g). For the combination of PFOB with α -tocopherol treatment the value increased to 1.45 ± 0.09 , ($p < 0.02$ against group 2), whereas allopurinol remained without effect (group 5: 0.808 ± 0.06).

The opposite tendency of GSSG can be observed in Fig. 3. GSSG increased from a basal level (group 1) of 19.3 ± 1.5 μ mol/g to 38.9 ± 3.6 μ mol/g in group 2 ($p < 0.005$). Under PFOB in group 3 the level was not further elevated (34.3 ± 3.3 μ mol/g); the difference to group 2 was insignificant. α -tocopherol caused a slightly significant ($p < 0.05$) decrease to 27.7 ± 0.9 μ mol/g as compared with group 2, whereas allopurinol remained without a significant effect (34.9 ± 2.8 μ mol/g).

The ratio GSSG/GSH increased considerably from 0.007 ± 0.001 in group 1 to 0.053

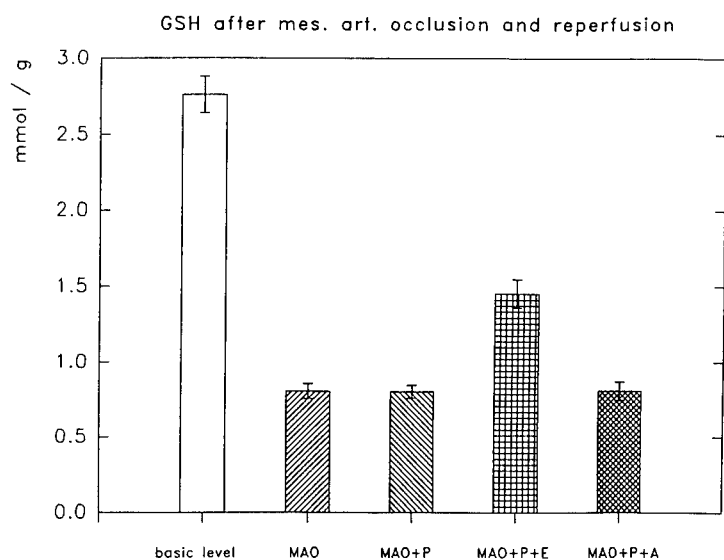

FIGURE 2. The content of GSH in the intestinal tissue of the tested groups. Significance of differences is given in the text.

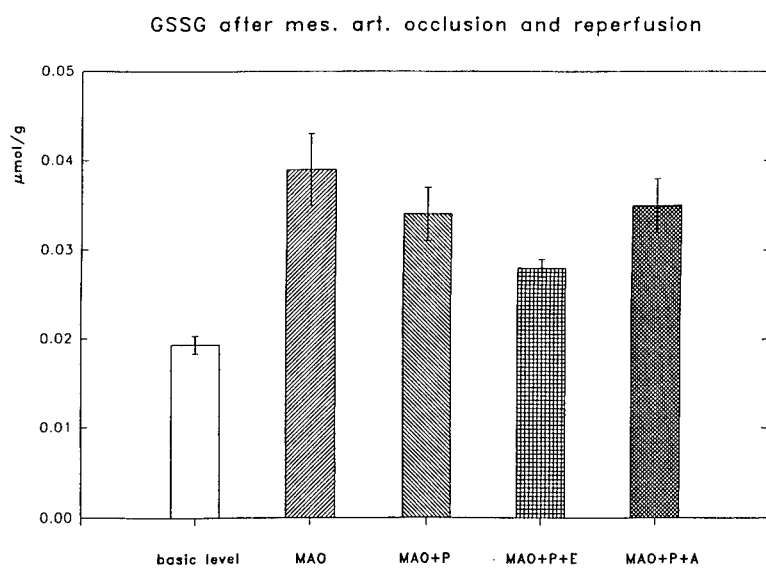

FIGURE 3. The content of GSSG in intestinal tissue under different conditions. Details like in Fig.1.

± 0.007 in group 2 ($p < 0.002$). Under PFOB no further increase occurred (0.043 ± 0.006). α -tocopherol treatment in combination with PFOB (0.019 ± 0.001) lowered significantly this ratio compared to group 2 ($p < 0.01$), whereas allopurinol remained without effect (0.045 ± 0.007).

Myeloperoxidase activity increased from a basic level of 3.88 ± 0.51 units/g in group 1 to 40.01 ± 4.83 in group 2 ($p < 0.001$, **Fig.4**). Together with PFOB no further increase occurred (group 3: 40.50 ± 4.23). In combination with α -tocopherol treatment the increase could be reduced to 21.14 ± 1.80 U/g ($p < 0.02$ against group 2), whereas allopurinol showed only a slight depression (group 5: 36.20 ± 3.02 U/g, n.sign.).

DISCUSSION

Mesenteric artery occlusion causes a far reaching interference with normal homeostasis. However, we have chosen this model to explore the influence of an artificial oxygen carrier during the reperfusion period, when a dramatic increase in the content of lipid peroxides was found to develop. Though a further increase of such products occurred under treatment with PFOB, our results show that the combination of PFOB with an antioxidant or a free radical scavenger depresses the level of peroxide products below that of operated, but otherwise untreated controls of group 2. Because a controversy exists relating to the capacity of the TBA reaction to evaluate real products of lipid peroxidation [14], a comparison with results of the determination of malondialdehyde-like substances with HPLC was undertaken, which showed a narrow relation between both methods, though TBARS values were higher by a factor of 2.24.

Allopurinol has besides its effect of inhibiting xanthine oxidase a well documented scavenging effect against the highly reactive hydroxyl radical and the myeloperoxidase-derived oxidant hypochlorous acid [15,16]. It depressed the increase in TBARS significantly, though the effect on the glutathione metabolism was negligible. Although the increase of myeloperoxidase could not be significantly prevented by allopurinol, there might be a protection against the consequences of liberating reactive radicals from activated polymorphonuclear leukocytes. α -tocopherol treatment acted significantly on all parameters investigated, it was more powerful than allopurinol in preventing GSH-depression and myeloperoxidase activation. Both agents have shown the capacity to counteract the creation of additional free radical products under these severe conditions.

Three of the four tests searching for aggravating consequences of lipid peroxidation under an elevated oxidative load remained negative. In case of an increase of TBARS,

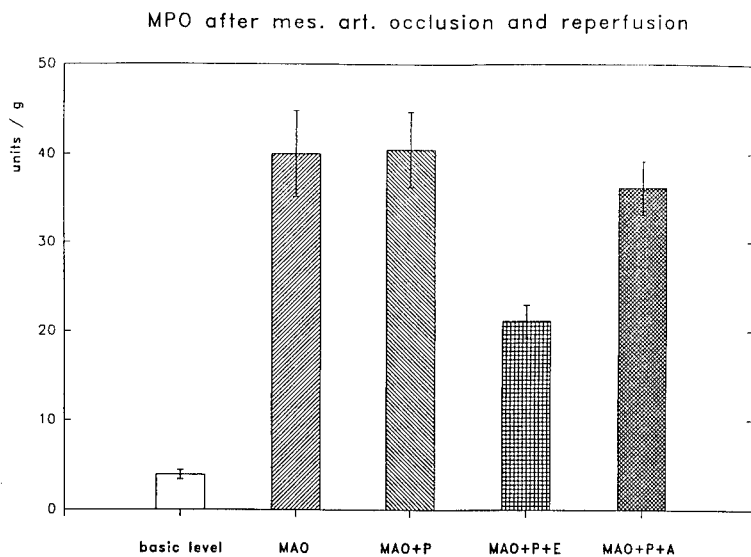

FIGURE 4. The content of myeloperoxidase in intestinal tissue under different conditions. Details see Fig.1.

this effect could be totally depressed below that of similarly operated controls by the combination with an antioxidant or a hydroxyl radical scavenger, and thus consequences could be mastered. Control experiments with simultaneous determination of TBARS and malondialdehyde-like substances by HPLC indicated a clear correlation and emphasized the significance of an antioxidative protection under extreme conditions like those in the described experiments.

REFERENCES

- [1] Augustin AJ, Lutz J: The effect of a temporary occlusion of the superior mesenteric artery on the level of lipid peroxides in plasma and intestinal tissue. *Pflug. Arch.* **411**, R51 (1988)
- [2] Lutz, J, Augustin, AJ: The influence of a temporary cessation and reperfusion of intestinal blood flow on the level of hepatic lipid peroxides. *Advanc. Exp. Med. Biol.* **248**, 803-808 (1989)
- [3] Lutz, J, Augustin AJ, Friedrich E: Severity of free oxygen radical effects after ischemia and reperfusion in the intestinal tissue and the influence of different drugs. *Advanc. Exp. Med. Biol.* **277**, 683-697 (1990)

- [4] Augustin AJ, Lutz J: Intestinal, hepatic and renal production of thiobarbituric acid reactive substances and myeloperoxidase activity after temporary aortic occlusion and reperfusion. *Life Sciences* 49, 961-968 (1991)
- [5] Lutz J, Augustin AJ, Purucker E, Milz J: Combination of treatment with perfluorochemicals and free radical scavengers. *Biomat. Art. Cells Immob. Biotech.* 20, 951-958 (1992)
- [6] Augustin AJ, Goldstein RK, Milz J, Lutz J: Influence of antibiotics and free radical scavengers on intestinal ischemia induced oxidative tissue damage. *Advanc. Exp. Med. Biol.* 316, 239-251 (1992)
- [7] Peerless SJ: The use of perfluorochemicals in the treatment of acute cerebral ischemia. In: *Advances in Blood Substitutes Research* (Eds. RB Bolin, RP Geyer, GJ Nemo) AR Liss Inc., N.York 353-362 (1983)
- [8] Riess JG, Dalfors JL, Hanna GK, Klein DH, Krafft MP, Pelura TJ, Schutt EG: Development of highly fluid, concentrated and stable fluorocarbon emulsions for diagnosis and therapy. *Biomat. Art Cells Immob. Biotech.* 20, 839-842 (1992)
- [9] Ohkawa H, Ohishi N, Yagi, K: Assay for lipid peroxides in animal tissues by thiobarbituric acid reaction. *Anal. Biochem.* 95, 351-358 (1979)
- [10] Esterbauer H, Cheeseman KK: Determination of aldehydic lipid peroxidation products: malondialdehyde and 4-hydroxynonenal. In: *Methods in Enzymology: Free Radicals and Metal Ions in Human Disease*. (Eds. L.Packer and A.N. Glarer) New York: Academic 190, 407-421 (1990)
- [11] Tietze F: Enzymic method for quantitative determination of nanogram amounts of total and oxidized glutathione. *Anal. Biochem.* 27, 502-522 (1969)
- [12] Griffith, OW: Determination of glutathione and glutathione disulfide using glutathione reductase and 2-vinylpyridine. *Anal. Biochem.* 106, 207-212 (1980)
- [13] Krawisz JE, Ohishi N, Yagi K: Quantitative assay for acute intestinal inflammation based on myeloperoxidase activity *Gastroent.* 87, 1344-50 (1984)
- [14] Fantini GA, Yoshioka T: Use and limitations of thiobarbituric acid reaction to detect lipid peroxidation. *Am. J. Physiol.* 263, H981-H982 (1992)
- [15] Moorhouse PC, Grootveld M, Halliwell B, Quinland JG, Gutteridge JMC: Allopurinol and oxypurinol are hydroxyl radical scavengers. *FEBS Letters* 213, 23-28 (1987)
- [16] Das DK, Engelman RM, Clement R, Otani H, Prasad MR, Rao PS: Role of xanthine oxidase inhibitor as free radical scavenger: a novel mechanism of action of allopurinol and oxipurinol in myocardial salvage. *Biochem. Biophysics. Res.* 148, 314-319 (1987)

PERFLUORODECALIN EMULSION TESTED FOR BIOCOMPATIBILITY
IN MACROPHAGES BY MEANS OF A MAGNETOMETRIC METHOD

M.Koester, J.Lutz, A.J. Augustin* and H. Meinert**

Dept. of Physiology, University of Wuerzburg, Germany

* Dept. of Clinical Ophthalmology, University of Bonn, Germany

**Dept. of Chemistry of Biocompatible Compounds, Univ. of Ulm, Germany

ABSTRACT

The effect of a stable perfluorodecalin (FDC) emulsion, based on addition of 0.2-0.5% (W/V) of perfluoroperhydrophenanthrene and 4% egg yolk lecithin was tested for its influence on Kupffer cells in vivo by means of a magnetometric procedure in rats. It was also compared with the effect of a perfluorochemical emulsion (PFC) of the first generation (Fluosol^R-DA, FDA). While doses of 0.1 g/kg body weight of both PFCs caused a small increase of activity in these cells (as measured by an increase in a ratio factor r after magnetization), doses of 1g/kg b.wt. led to a significant retardation of intracellular movements after FDC and FDA for two and four days, respectively. A dose of 3 g/kg b.wt. of FDC effected a significant depression for 8 days, whereas after the same dose of Fluosol-DA the intracellular motility remained depressed for as long as 32 days.

INTRODUCTION

The favourable features of perfluorodecalin (FDC) mark it as a potential candidate for artificial oxygen transport as well as a heavy liquid for vitreoretinal tamponade. Whereas the agent can be used for postoperative tamponade within

the eye in a pure form, it has to be emulsified when it is to be utilized as a "blood substitute". Emulsification has turned out to be very difficult; only a mixture with 30% of perfluorotripropylamine (FTPA, combined as Fluosol[®]-DA, FDA [1,2]) proved to be stable enough when kept in a frozen state. However, storage of this emulsion in macrophages continued for more than 30 days. Now by addition of 0.2-0.5% of perfluoroperhydrophenanthrene a more stable form of FDC was prepared. We tested this emulsion for its effect on the functional activity of sessile macrophages of the liver [3-5] in doses relevant to intraocular and intravascular application by means of a magnetometric measurement.

Ferromagnetic particles, small enough to be taken up by cells of the reticulo-endothelial system, especially Kupffer cells of the liver, offer an opportunity to monitor cytoplasmic motility [6-8]. After being aligned by an external magnetic field for a short time period, they become reorientated, depending on their burden with other phagocytized material. Reorientation (also called "relaxation") can be measured by an external magnetic probe noninvasively in laboratory animals.

METHODS

The magnetometric method used was described previously [9-12] in detail [13]. Male Wistar rats received intravenously 5 mg/kg b.wt. of ferromagnetic iron oxide particles before i.v. administration of doses of either 0.1, 1 or 3 g/kg b.wt. of FDC or FDA. Following this they could be magnetically measured for a time period of about thirty days, which was done in several time intervals.

For each measurement the animals were slightly anesthetized with 30 mg/kg b.wt of pentobarbital and magnetized in a magnetic field of 0.26 Tesla (2600 Gauss) for 30 s. Immediately thereafter they were put into a magnetically shielded chamber. The depilated skin area above the right lower rib corner was brought in close contact to a double FOERSTER probe. The decay of the remanent magnetic field strength, measured in nTesla, was recorded for at least 10 min and the measurements were repeated three times. From the descending curves of magnetic field strength 12 time-dependent values were obtained within the interval of 0.25 and 10 min after the end of magnetization.

The curves were fitted logarithmically by the method of least squares and the following equation was calculated:

$$y = y_0 * e^{-k * t} + C$$

y = total magnetic field strength at the time t , y_0 = "dynamic" field strength, e = base of natural logarithms, k = relaxation constant, C = "static" or "stable" magnetic field strength.

The absolute size of y_0 for the dynamic part of magnetism as well as the static part C are to a certain degree dependent on the geometrical position of the magnetic probe in relation to the animal's surface and so cause larger interindividual variations. k , which represents the relaxation is a measure of the re-orientation of the fully movable particles only, whereas the hampered ones do not contribute to this factor. In contrast to these parameters, the relation

$$r = y_0 / (y_0 + C)$$

which stands for the ratio of the dynamic to the total magnetic field strength remains independent of those variations and is a well defined factor for the movable portion of the received ferromagnetic material. Thus we used this ratio to express changes of intracellular particle motion during the longitudinal studies.

Statistical analysis of differences was performed according to Student's two-tailed t-test with an extension according to Behrens-Fisher when variances were unequal [12]. All data are given as mean \pm standard error of the mean. Differences were considered significant if p was < 0.05 .

RESULTS

After doses of both PFCs comparable to the application in the eye (0.1 g/kg), no reduction of the intracellular mobility of the iron particles could be seen at any time. To the contrary, even an improvement of particle motion was found, expressed by an increase of r , which was distinct, though not statistically significant for each of the two PFCs. Following a dose of 1 g FDC/kg b.wt. r

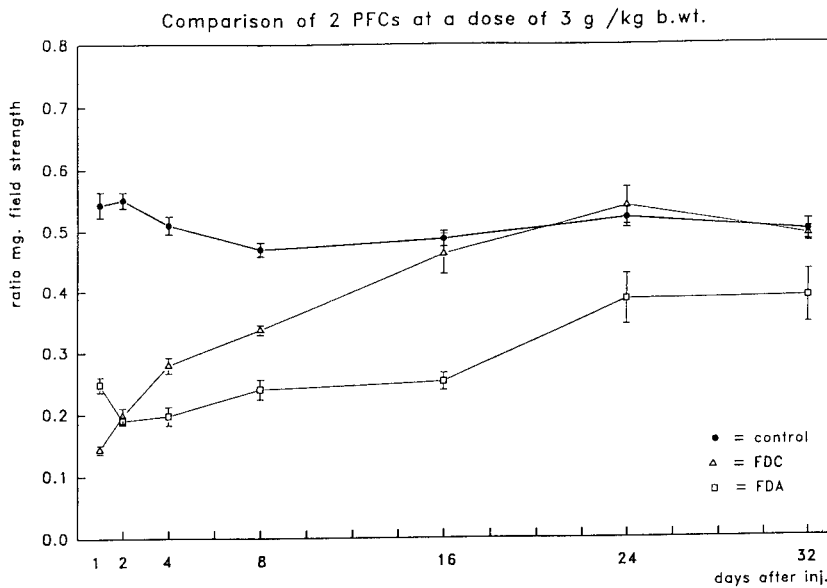

FIGURE 1. Ratio of the magnetic field strength r in controls and after treatment with 3 g FDC or FDA per kg b.wt. Significance of differences is given in the text.

was depressed to $84.5\% \pm 2.7$ of the control ($p < 0.01$) until the second day after injection. The same dose of FDA caused a depression to $79.2\% \pm 6.9$ until the fourth day after injection ($p < 0.05$). After a dose of 3 g/kg b.wt. of FDC the intracellular movement was still depressed on the 8th day after administration to $71.6\% \pm 1.3$, compared with $51.1\% \pm 2.7$ after 3 g/kg b.wt. of FDA (both $p < 0.001$ versus control). Sixteen days after injection no significant diminution of magnetic relaxation could be detected in the group which received 3 g FDC/kg b.wt.; in the group with 3 g FDA/kg b.wt. the plasmic motion was still depressed to $51.8\% \pm 3.1$ ($p < 0.001$), while as late as 32 days after the injection it still was reduced to $78.1\% \pm 6.7$ of control ($p < 0.05$), (Fig.1).

CONCLUSION

Omitting FTPA in the emulsion of FDC resulted in a significant improvement concerning the depressing effect on the action of macrophages. In doses rele-

vant for eye surgery no evidence of retardation could be detected for either PFC, whereas amounts of 1 and 3 g FDC/kg resulted in a reversibly diminished magnetic relaxation until the 2nd or until the 8th day, respectively. In contrast, FDA at a dose of 3 g/kg b.wt. caused a depressed relaxation lasting for more than 32 days. Thus only at low doses are differences between these two substances negligible, while they play an increasingly important role at the higher doses utilized in blood substitution products.

REFERENCES

1. R. Naito and K. Yokoyama (1978): Perfluorochemical blood substitutes Fluosol-43, Fluosol-DA 20% and 35%. Technical Information No 5, Green Cross Corp., Osaka
2. K. Yokoyama, K. Yamanouchi, H. Ohyanagi and T. Mitsuno (1978): Fate of perfluorochemicals in animals after intravenous injection or hemodilution with their emulsions. *Chem. Pharm. Bull.* 26, 956-966
3. J. Lutz, A.J. Augustin and J. Milz: Measurement of magnetic relaxation above the liver by means of needle-shaped gamma Fe_2O_3 particles. *Pflug. Arch. Europ. J. Physiol.* 415 R 44 (1990)
4. J. Lutz, A.J. Augustin, J.S. Schwegler and J. Milz: Magnetometric studies on the reticulo-endothelial system of the liver after administration of different lipid emulsions. *Life Sciences* 50, 1503-1510 (1992)
5. M.B. Koester and J. Lutz: Magnetometric measurements of macrophage activity in the liver after administration of different perfluorochemicals. *Advanc. Exp. Med. Biol.* (accepted for printing)
6. P.A. Valberg and D.F. Albertini: : Cytoplasmic motions, rheology, and structure probed by a novel magnetic particle method. *J. Cell Biol.* 110 130-140 (1985)
7. P.A. Valberg and H.A. Feldman: Magnetic particle motions within living cells. Measurement of cytoplasmic viscosity and motile activity. *Biophys. J.* 52 551-561 (1987)
8. P. Gehr, S. Schuerch, M. Geiser, V. Im Hof and Ch. Furter: Magnetic field relaxation with cell-substrate adhesive interactions. In: *Biomagnetism '87* (Eds. K. Atsumi, M. Kotani, S. Ueno, T. Katila and S.J. Williamson) Tokyo Denki University Press, Tokyo, pp. 358-361 (1988)
9. D. Cohen, I. and I. Nemoto: Ferrimagnetic particles in the lung Part I: The magnetizing process. *IEEE Trans. Biomed. Eng.* BME-31 261-273 (1984)

- 10.D. Cohen, I. Nemoto, L. Kaufman and S. Arai: Ferrimagnetic particles in the lung Part II: The relaxation process. *IEEE Trans. Biomed. Eng.* BME-31 274-284 (1984)
- 11.P. Gehr, J.D. Brain and S.B. Bloom: Noninvasive studies of Kupffer cells in situ by magnetometry. *J. Leukocyte Biol.* 35 19-30 (1984)
- 12.S.B. Weinstock, J.D. Brain, C.E. Keller-McGandy, K.R. Taylor, R. Eccles, P. Gehr and R.P. Geyer: Measurement of phagosomal motion by non-invasive magnetometry in Kupffer cells of rats treated with per-fluorochemicals. In: *Cells of the Hepatic Sinusoid, Vol. 1* (Eds. A. Kirn, D.L. Knook and E. Wisse) Kupffer Cell Foundation, The Netherlands pp. 51-52 (1986)
- 13.S.B. Weinstock and J.D. Brain: Comparison of particle clearance and macrophage phagosomal motion in liver and lungs of rats. *J. Appl. Physiol.* 65 1811-1820 (1988)
- 14.S. Dowdy and S. Wearden: *Statistics for research*. Wiley & Sons, New York N.Y. (1983)

**THE EFFECT OF MODERATE HEMODILUTION WITH FLUOSOL® ON
CYTOCHROME P4502D6 ACTIVITY IN THE RAT**

R.P. Shrewsbury, S.R. Oliver, L.G. White
University of North Carolina at Chapel Hill
School of Pharmacy
Division of Pharmaceutics, Chapel Hill, N.C. 27599-7360

ABSTRACT

Desmethylinipramine (desipramine, DMI) is predominantly 2-hydroxylated to 2-hydroxydesipramine, and the remainder is N-demethylated to didesmethylipramine (DDMI) in both rats and man. DMI 2-hydroxylation is mediated by the same cytochrome P-450 isoenzyme (P4502D6) in rats and man. Fluosol hemodilution has previously been shown to influence the activity of P4502B1 and P4502B2, the cytochrome P-450 isoenzymes induced by phenobarbital in rats. In this study, DMI was used as a model substrate to investigate the influence of moderate Fluosol hemodilution on P4502D6 activity in rats. DMI total body clearance was not influenced by Fluosol hemodilution. This was an anticipated outcome since phenobarbital had a negligible effect on DMI metabolism, and Fluosol and phenobarbital affect the same isoenzymes. DMI V_{dss} was increased at 0.5 hour after hemodilution, but decreased from 24-72 hours. The decreased V_{dss} is most likely due to increased concentrations of alpha-1-acid-glycoprotein. Thus, Fluosol hemodilution is not expected to influence the hepatic P4502D6 activity in man. However, Fluosol may have marked influences on the apparent volumes of distribution of basic drugs that bind to alpha-1-acid-glycoprotein.

INTRODUCTION

Imipramine (IMI) is predominantly metabolized in rat liver microsomes by cytochrome P-450 isoenzymes to desipramine (desmethylinipramine, DMI) by aliphatic N-demethylation, and 2-hydroxyimipramine by aromatic 2-hydroxylation. These primary metabolites are further 2-hydroxylated and N-demethylated, respectively, to the common secondary metabolite 2-hydroxydesipramine (2OH-DMI). DMI also undergoes N-demethylation to didesmethylimipramine (DDMI). The 2-hydroxylated metabolites of IMI and DMI are further conjugated to glucuronides [1, 2].

It has been demonstrated that N-demethylation and 2-hydroxylation are mediated by two different isoenzymes [1, 2]. It was recently reported that rats and humans have the same cytochrome P-450 isoenzyme involved in the 2-hydroxylation of dextromethorphan and debrisoquin [3]; the isoenzyme is designated as P4502D6 in humans [4]. Genetic polymorphism is a prominent feature of P4502D6 function in humans; 5-10% do not express the isoenzyme [5, 6].

Moderate Fluosol hemodilution has previously been reported to influence the activity of the phenobarbital inducible P4502B1 and P4502B2 isoenzymes in rats [7, 8]. In this study, the influence of Fluosol hemodilution on P4502D6 activity in rats is reported. DMI was chosen as the P4502D6 isoenzyme substrate since *in vitro* human and rat liver microsome studies have shown that the formation of 2OH-DMI accounts for approximately 80% of DMI clearance [5, 6, 9].

MATERIALS AND METHODS

Fluosol was donated by Alpha Therapeutics, Inc. (Los Angeles, CA) and prepared as directed within 0.5 hour of use. For intravenous administration, a solution of desipramine hydrochloride (Sigma Chemical Co., St. Louis, MO) 10 mg/mL was prepared in distilled water. HPLC solvents and buffers were obtained from commercial vendors. Male Sprague-Dawley albino rats, 320 \pm 25 grams (mean \pm SD), were used without abstinence from food or water.

The study protocol and procedures were identical to those previously reported for the P4502B1 and P4502B2 activity studies [7]. Rats were partially exchanged with 40 mL/kg of Fluosol and received a 5 mg/kg desipramine dose at 0.5, 24, 48, or 72 hours after the exchange. One group of rats, serving as controls, were not exchanged, but dosed with desipramine. The group designations are CONT for the control group, and 0.5HF, 24HF, etc. for the time (in hours) following the exchange that the animals received the desipramine dose.

Blood samples were collected in heparinized polypropylene tubes at 15, 30, 60, 90, 120, 240, and 420 minutes, and the plasma harvested. For HPLC analysis, 0.1 mL of plasma was taken, 0.075 mL of imipramine hydrochloride (0.0025 mg/mL, internal standard), 5 mg of sodium carbonate, and 1 mL of hexane were added. The mixture was shaken for 5 minutes, centrifuged for 2 minutes, the aqueous layer frozen in dry ice, and the organic layer collected and evaporated under nitrogen. The residue was reconstituted with 0.12 mL of methanol, and samples were injected into the chromatograph. The common practice of acid back extraction was not done since unidentified peaks were found when desipramine was back extracted into 0.1M HCl in polypropylene centrifuge tubes [10].

Desipramine plasma concentrations were determined with a 5 micron CN (250x4.6mm i.d.) Alltech column and a mobile phase of methanol:acetonitrile:buffer (43:47:10) at a flow rate of 1.1 mL/min. The buffer was 0.012M KH_2PO_4 adjusted to pH 6.7. Absorbency was monitored at 254 nm (0.005 AUFS) and the peak area ratio of desipramine to internal standard was determined. Standard curves were prepared using plasma from unexchanged animals or rats exchanged with Fluosol.

A two-compartment pharmacokinetic model was fit to the plasma concentration versus time data using the nonlinear regression program NLIN of SAS (SAS Institute, Cary, NC). Plasma concentrations were weighted by their reciprocal squared since the coefficient of variation was dependent upon the concentration assayed. Parameter estimates from the fitted data were used to subsequently calculate desipramine half-life ($t_{1/2}$), clearance (Cl), and volume of distribution at steady-state (V_{dss}). The significance of difference between any group was assessed with the

Wilcoxon Rank Sums (Kruskal-Wallis test) with a probability of $p \leq 0.05$ considered statistically significant.

RESULTS

The hemodilution procedure used in this study reduced the hematocrit approximately 50% (data not shown); the reductions were very similar to data previously reported [11]. The animals underwent the hemodilution procedure and subsequent pharmacokinetic study without supplemental oxygen. There was no averaged weight change for any group during the study period.

Table I shows the DMI parameters determined from the two compartment fittings of plasma concentration versus time data. DMI Cl was significantly greater than CONT in the 0.5HF group, but was decreased for 24-72 hours. The 48HF and 72HF groups did not reach the level of significance.

V_{dss} was increased in the 0.5HF group, although it was not statistically different than CONT due to the large variation (SD). Values were decreased in all other groups; statistically different V_{dss} values were found in the 24HF and 72HF groups. Since Cl and V_{dss} varied in the same direction within each group, the dependent parameter $t_{1/2}$ was not found to be different from CONT.

DISCUSSION

Previous studies evaluating DMI pharmacokinetics in male rats have reported a range of $t_{1/2}$ values from 3.3 to 13.0 hours [12-17]. DMI doses ranged from 5 mg/kg to 25 mg/kg in these studies. In the current study, a 5 mg/kg desipramine dose was administered and the averaged $t_{1/2}$ in the CONT group was 5.3 hours. The $t_{1/2}$ values in the earlier studies were primarily obtained using a one compartment model to fit a limited number (3 or 4) of DMI concentration values. A two compartment fit was clearly required to adequately describe the DMI plasma concentration profile in the present study.

The V_{dss} of DMI was reported to be 25 L/kg, and plasma Cl could be estimated to be 54 ml/min/kg [13]. In this current study, both V_{dss} and Cl were less than the previous report. Confidence in the previous study is

TABLE I. Averaged desipramine pharmacokinetic parameters at various times following hemodilution with 40 mL/kg Fluosol.

Parameter	CONT	0.5 HF	24 HF	48HF	72 HF
Cl (ml/min/kg)	32.9±1.3 [†]	93.3±33.7*	14.9±1.2*	23.6±12.6	29.8±5.9
V _{dss} (ml/kg)	12217±1824	23069±15637	3137±482*	7384±3528	5984±1843*
t _{1/2} (min)	316.3±68.7	224.5±152.0	224.5±35.4	400.8±359.1	200.3±43.7

[†] Mean±S.D.

*Significantly different from CONT (p<0.05); n=3-5

reduced since a one compartment model was used to fit a limited number of DMI plasma values, and radiolabelled DMI was used. DMI undergoes N-demethylation to DDMI, which has a longer t_{1/2} than DMI [12].

DMI Cl appears to change in a transient manner for the first 24 hours, but returns to CONT values after that time. The lack of a prolonged Fluosol hemodilution influence on DMI Cl was not unexpected. Several reports have established that both Fluosol and phenobarbital induce the same isoenzymes (P4502B1 and P4502B2) in rats [see 7 and 8 for additional references]. The influence of phenobarbital on DMI metabolism in male Sprague-Dawley rats was found to be negligible [13, 17]. Therefore, it was anticipated that Fluosol hemodilution would have a minimal influence.

DMI V_{dss} was reduced after 24 hours and remained depressed for 72 hours. The most plausible explanation for this decrease is an increased alpha-1-acid-glycoprotein (AAG) concentration secondary to Fluosol hemodilution. DMI is known to bind to AAG, as well as apolipoprotein B, and complement C3_c [6]. *In vitro* studies have demonstrated that AAG in phenobarbital treated rats binds DMI more strongly than control rats [17, 18]. Further, it was reported that serum AAG concentrations increase in phenobarbital treated rats. Since Fluosol and phenobarbital influence the same hepatic isoenzymes regulating drug metabolism, they may also influence the same enzymes regulating AAG production.

REFERENCES

1. M Chiba, S Fujita, T Suzuki. *J Pharm Sci* 77:944-947 (1988).
2. M Chiba, S Fujita, T Suzuki. *J Pharm Sci* 79:281-287 (1990).
3. HM Kandil, DJ Hermann, J Lu, MJ Koruda, WT Sawyer, *et al.* *J Nutri Biochem* 3:442-446 (1992).
4. DW Nebert, DR Nelson, MJ Coon, RW Estabrook, R Feyereisen, *et al.* *DNA and Cell Biology* 10:1-14 (1991).
5. K Brosen. *Clin Pharmacokinet* 18:220-239 (1990).
6. FR Sallee, BG Pollock. *Clin Pharmacokinet* 18:346-364 (1990).
7. RP Shrewsbury, LG White. *Res Commun Chem Path Pharmacol* 67:411-414 (1990).
8. RP Shrewsbury. *Biomat, Art Cells & Immob Biotech* 20:1037-1043 (1992).
9. E Skjelbo, K Brosen, J Hallas, LF Gram. *Clin Pharmacol Ther* 49:18-23 (1991).
10. D Argenti, A Dmello. *Clin Chem* 37:1468 (1991).
11. RP Shrewsbury, LM Lewis, SR Oliver, CL Womble. *J Pharm Pharmacol* 39:592-598 (1987).
12. JV Dingell, F Sulser, JR Gillette. *J Pharmacol Exp Ther* 143:12-22 (1964).
13. C VonBahr, B Alexanderson, DL Azarnoff, F Sjoqvist, S Orrenius. *Europ J Pharmacol* 9:99-105 (1970).
14. PD Hrdina, TC Dubas. *Can J Physiol Pharmacol* 59:163-167 (1981).
15. RW Fuller, KW Perry. *Res Commun Chem Path Pharmacol* 66:375-384 (1989).
16. MJ Moor, SH Steiner, G Jachertz, MH Bickel. *Pharmacol & Toxicol* 70:121-124 (1992).
17. U Breyer-Pfaff, T Spribille, I Jahns. *Biochem Pharmacol* 27:1521-1526 (1978).
18. TH Lin, Y Sawada, Y Sugiyama, T Iga, M Hanano. *J Pharm Pharmacol* 37:735-738 (1985).

PERFLUOROCARBON DISTRIBUTION TO LIVER, LUNG AND SPLEEN OF EMULSIONS OF PERFLUOROTRIBUTYLAMINE (FTBA) IN PIGS AND RATS AND PERFLUOROOCYL BROMIDE (PFOB) IN RATS AND DOGS BY ¹⁹F NMR SPECTROSCOPY.

A.J. McGoron¹, R. Pratt², J. Zhang², Y. Shiferaw², S. Thomas² and R. Millard¹
Departments of Pharmacology and Cell Biophysics¹ and Radiology²
University of Cincinnati, Cincinnati, Ohio USA 45267-0575

Perfluorocarbon emulsion (FCE) particles are reported to be taken up by the reticuloendothelial system (RES) and ultimately eliminated by the lung. This distribution provides an opportunity to measure oxygen partial pressure *in vivo* with fluorine -19 magnetic resonance imaging (¹⁹F MRI). Since the MR image signal-to-noise ratio is directly proportional to the fluorine concentration in the tissue, a greater concentration of perfluorocarbon (PFC) in the tissue will result in a greater confidence in the oxygen image and reduce measurement time. It was postulated that the biodistribution of PFC administered in emulsion form may depend on species RES or FCE composition. The distribution of an emulsion (OxypherolTM-E.T.) containing perfluorotributylamine (FTBA) 5 days after administration to pigs (11 g FTBA/kg body weight i.p.) and rats (19 g FTBA/kg i.p.) and an emulsion (OxygentTM) containing perfluorooctyl bromide (PFOB) 7 days after administration to dogs (11 g PFOB/kg i.v.) and 5 days after administrations to rats (19 g PFOB/kg i.p.) was analyzed by F-19 NMR spectroscopy of tissue samples. PFC concentrations in spleen are 2 to 3 times those in liver. This pattern appears to be independent of PFC emulsion or species. In contrast, lung PFC content was less than that in the liver and showed a dependence upon both species and PFC emulsion.

INTRODUCTION

Success in the development of efficacious blood substitutes intended for human use has led to novel perfluorocarbon emulsions (FCE) [1]. However, to date only one formulation containing perfluorodecalin and perfluorotripropylamine (Fluosol-DA™, Alpha Therapeutics Corp., Los Angeles, CA) has gained FDA approval for human use. Other formulations containing other perfluorocarbons and perfluorocarbon mixtures are currently under development (Oxygen™, Alliance Pharmaceutical Corp. [2]; HM351, Hemagen/PFC Corp.; in other articles in this volume). FCEs may have advantages over conventional crystalloid volume expanders due to their greater oxygen solubility [3]. Magnetic resonance imaging (MRI) has been used to image the intravascular space as well specific organs (e.g. liver, lung and spleen) in which the perfluorocarbon (PFC) perfluorotripropylamine (FTBA) is preferentially concentrated [4]. The biodistribution of injected PFC to certain organs, especially those of the reticuloendothelial system (RES), provides an opportunity to measure oxygen partial pressure *in vivo* with ^{19}F NMR [5,6,7]. Tissue oxygen maps of liver, lung and spleen have been obtained based on the effect of paramagnetic molecular oxygen which reduces the measured ^{19}F T_1 relaxation time.

NMR signal to noise ratio is directly proportional to the PFC concentration in the tissue. A larger PFC concentration provides a greater confidence in the oxygen image and reduces measurement time. Pigs have been reported to accumulate PFC in their lungs in the same proportion as their liver [4] compared to rats which accumulate lesser quantities in their lungs [8]. Some species (pigs) have acute cardiovascular reactions to i.v. administration of emulsions not evident with i.p. injections. FCE containing perflubron (perfluorooctyl bromide, PFOB) was administered to dogs (i.v.) and rats (i.p.) while FCE containing perfluorotripropylamine (FTBA) was administered to pigs (i.p.) and rats (i.p.) to compare biodistribution of PFC following either i.v. or i.p. administration. We hypothesized that the distribution and elimination of PFC is independent of the route of administration or FCE formulation.

MATERIALS AND METHODS

Male beagle dogs (8-12 kg, n=3) were chronically instrumented with medical grade tygon catheters in the femoral artery and vein. The catheters were led subcutaneously to exit in the mid dorsal region for subsequent FCE administration

and blood sampling. After a four day recovery period the conscious animals were given 11g PFC/kg body weight PFOB emulsion (Oxygent™, 90% w/v) i.v. Seven days later animals were euthanatized and liver, lung and spleen were weighed. Tissue samples were stored at -20°C for subsequent ¹⁹F NMR spectroscopic analysis of specific PFC content.

Farm raised swine (8-12 kg, n=5, female) were given atropine (80 µg/kg, i.m.) to reduce salivation and preanesthetized with ketamine (10 mg/kg, i.m.) to allow anesthesia with sodium thiamylal (10 mg/kg, i.v.) initially and with supplemental doses as required for stage 3 anesthesia throughout the procedure. Warm (37° C) Oxypherol™-E.T. (500 ml of emulsified FTBA 20% w/v, Alpha Therapeutics Corporation, Los Angeles, CA) was administered by gravity through a sterile 14 ga needle/catheter inserted transcutaneously into the peritoneal cavity. The animals were allowed to recover and were conscious and upright within an hour. Four days later each animal was euthanatized and liver, lung and spleen samples were weighed and stored for specific PFC content determination by ¹⁹F NMR spectroscopy.

Rats were anesthetized with sodium pentobarbital (35 mg/kg) and warmed FCE (19 g PFC/kg body weight of either Oxypherol™-E.T., n=6 or Oxygent™, n=3) was administered by injection through a sterile 18 ga needle/catheter inserted into the peritoneal cavity. Five days later the animals were euthanatized and liver, lung and spleen were weighed and stored for ¹⁹F NMR spectroscopy.

RESULTS

Conscious unsedated dogs showed no reaction during or after intravenous infusion of Oxygent™. No animals receiving i.p. injections (pigs or rats) showed any reaction or response to the FCE after recovering from the anesthesia. All animals behaved normally during the period between drug infusion and euthanasia. No PFC could be detected by centrifugation or ¹⁹F spectroscopy in the blood of animals at the time of euthanasia. Comparisons were made using an unpaired Student's t test at the 95% significance level. In every case the spleen contained more PFC per gram tissue than other organs examined (Table I). Rat spleens did not contain twice the PFC concentration as in the spleen of pigs or dogs despite their being given nearly double the PFC/kg body weight dose.

Concentration of PFC in tissue was normalized by dividing the measured g PFC per g tissue by the initial PFC dose (g PFC per kg body weight). The pigs

TABLE I: Distribution of PFC (MEAN \pm SEM, g PFC/g tissue) to liver, spleen and lung 7 days after administration to dogs or after 5 days in pigs or rats

Species	PFC (route)	Liver	Spleen	Lung
Beagle (n=3)	PFOB (i.v.)	0.09 \pm 0.01	0.32 \pm 0.02	0.04 \pm 0.02
Rat (n=3)	PFOB (i.p.)	0.15 \pm 0.01	0.50 \pm 0.04	0.12 \pm 0.00
Rat (n=6)	FTBA (i.p.)	0.13 \pm 0.01	0.33 \pm 0.03	0.03 \pm 0.01
Pig (n=5)	FTBA (i.p.)	0.10 \pm 0.01	0.37 \pm 0.03	0.10 \pm 0.01

retained significantly more FTBA in their spleen (93%, $p < 0.01$) and lung (433%, $p < 0.001$) than did rats (Figure 1). Rats administered perflubron emulsion retained more PFC in their spleen (52%, $p < 0.05$) and lung (279%, $p < 0.001$) than rats administered perfluorotributylamine emulsion (Figure 2). PFOB distribution to liver, spleen and lung of beagles and rats was not different when normalized to initial dose (Figure 3). Liver concentrations of PFC were not different among three species and two PFCs when normalized to initial dose.

CONCLUSIONS

Intraperitoneal injection of perfluorocarbon emulsion is a safe and effective technique to load RES organs with perfluorocarbon allowing them to be imaged by ^{19}F MRI. PFC is compartmentalized primarily into spleen, liver and lung. Intraperitoneal injection of 11 g FTBA/kg as OxypherolTM-E.T. is sufficient to obtain ^{19}F MR images and greater amounts of PFC may not be taken up by RES organs and tissues. Pig lungs sequester greater amounts of PFC than do lungs of other species, although this may be PFC or emulsion composition dependent. Staub [9] and Winkler [10] showed a species dependence on pulmonary intravascular macrophages which may be responsible for the acute hemodynamic response following intravenous injection of emulsion or particle suspension in pigs observed by us [11] and others [12]. To avoid this response, pigs were administered FCE by i.p. injection. The intravascular macrophages may also provide a mechanism for enhanced uptake of FCE or other liposomes in the lungs of pigs and other related species [13]. Pulmonary macrophages may account for the larger amount of FTBA in the pig lung compared to those of the rats given twice the amount of OxypherolTM-E.T. by the same route of administration. There were only slightly greater concentrations of PFOB in rat lungs compared to FTBA in pig lungs despite double the loading. Macrophages and monocytes in the spleen take

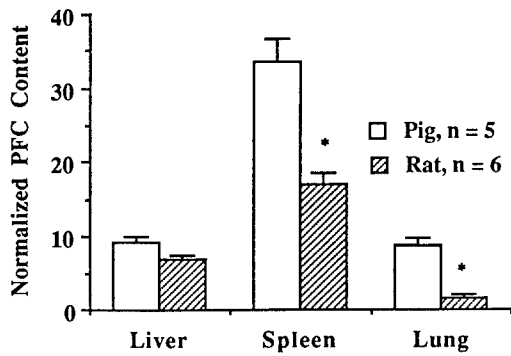

FIGURE 1: FTBA content in Pig and Rat tissue (MEAN \pm SEM) normalized to initial dose. (* p < 0.01)

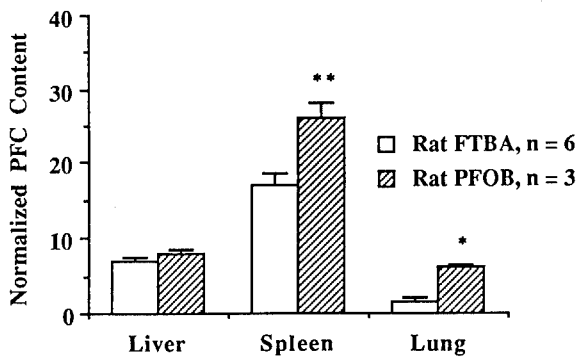

FIGURE 2: PFC content in Rat tissue (MEAN \pm SEM) normalized to initial dose. (* p < 0.01, ** p < 0.05)

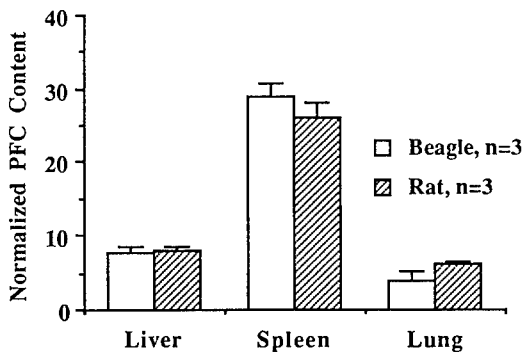

FIGURE 3: PFOB content in Beagle and Rat tissue (MEAN \pm SEM) normalized to initial dose.

up large quantities of FCE particles [14] which may account for the preferential uptake of PFC by spleen as noticed for each species and PFC regardless of the route of administration.

Pulmonary macrophages can not explain the dramatic difference in the PFC content of the lung of rats given PFOB compared to those given FTBA. The concentration of PFOB in rat lung and spleen was greater than FTBA despite being given the same total PFC dose. Perfluorocarbon structure or PFC emulsion formulation may also affect its biodistribution and elimination. Molecular weight may be the greatest determining factor for PFC elimination [15]. Critical solution temperature (CST), a function of the number of fluorine and carbon atoms in the PFC and thus a function of molecular weight, and vapor pressure, which is inversely related to molecular weight, have been shown to correlate with PFC whole body half life [16,17]. FTBA ($C_{12}F_{27}N$) has a higher CST but a lower vapor pressure than PFOB ($C_8F_{17}Br$) both of which probably contribute to FTBA's longer tissue retention time. The lipophilic nature of PFOB as well as a higher vapor pressure (as compared to FTBA) may result in increased uptake in rat lung but also may allow a more rapid elimination from the body [15]. The PFC concentration in beagle organs (PFOB administered i.v.) was lower than in organs in all other subjects (pigs and rats administered PFC i.p.). Even though twice as much PFC was given to the rats compared to the pigs or dogs there was not a significantly greater concentration of PFC in the spleens of either rat group. This may indicate that the accumulation of PFC by the spleen becomes saturated at less than 11 g PFC/kg body weight.

Following i.v. doses of 4 g/kg FTBA less than 0.1% was eliminated by feces and none by urine over 2 weeks post FCE injection [18]. The time for half of an administered dose of 5 g PFOB/kg body weight i.v. from rats to be eliminated via respiration was 11 days and longer for larger doses [19] suggesting that much less than half of the PFC initially administered was lost before euthanasia in our study. Normalized to initial dose the liver, lung and spleen of beagles and rats given the same PFC (PFOB) but by different routes (i.v. and i.p. respectively) retained the same amounts of PFC per gram tissue suggesting that the biodistribution of PFC may be independent of the route of FCE administration.

ACKNOWLEDGEMENTS

This work was supported in part by grant # HL-45243 and HL-22619 (Core I). A.J. McGoron is an NIH Postdoctoral Fellow supported by HL-07382. Oxygent™ used in this study was provided by Alliance Pharmaceutical Corp.

REFERENCES

1. J.G. Riess, *Biomat., Art. Cells & Immob. Biotech.* **20**:183-202 (1992)
2. J.G. Riess, J.L. Dalfors, G.K. Hanna, D.H. Klein, M.P. Krafft, T.J. Pleura and E.G. Schutt, *Biomat., Art. Cells & Immob. Biotech.* **20**:839-842 (1992)
3. J. G. Riess and M. Leblanc, in *Blood Substitutes: Preparation, Physiology and Medical Applications*, K. Lowe, Editor. Ellis-Horwood: New York. 94-129 (1988)
4. R.G. Pratt, S.R. Thomas, R.W. Millard, R.C. Samaratunga, and M.H. Naseem, *Biomat., Art. Cells & Immob. Biotech.* **20**:921-924 (1992)
5. R.F. Mattery, J. Schumacher, H.T. Tran, Q. Guo, and R.B. Buxton, *Biomat., Art. Cells & Immob. Biotech.* **20**:917-920 (1992)
6. R.P. Mason, F.M.H. Jeffrey, C.R. Malloy, E.E. Babcock, and P.P. Antich, *Mag. Res. Med.* **27**:1-7 (1992)
7. L. Clark, Jr., J. Ackerman, S. Thomas, R. Millard, R. Hoffman, R. Pratt, H. Ragle-Cole, R. Kinsey, and R. Janakiraman, *Adv. Exp. Med. Biol.* **180**:835-846 (1984)
8. H. Okamoto, K. Yamanouchi, and K. Yokoyama, *Chem. Pharm. Bull.* **23**:1452-1457 (1975)
9. N.C. Staub, *Chest.* **93**:84S-85S(1988)
10. G.C. Winkler, *Am. J. Anat.* **181**:217-234 (1988)
11. Y. Hermoni, R. Millard, and M. Gabel, *Fed. Proc.* **46**:519 (1987)
12. S.F. Flaim, D.R. Hazard, J. Hogan, and R.M. Peters, *Invest. Radiol* **26**:S122-S124 (1991)
13. K. Miyamoto, E. Schultz, T. Heath, M.D. Mitchell, K.G. Albertine, and N.C. Staub, *J Appl. Physiol.* **64**(3):1143-1152 (1988)
14. M.L. Miller, E.P. Wesseler, S.C. Jones, and L.C. Clark, Jr., *J. Reticulo. Soc.* **20**:385-398 (1976)
15. J.G. Riess, J. Greiner, M. Le Blanc, A. Manfredi, S. Pace, C. Varescon, and L. Zarif, *Biomat. Art. Cells Art. Organs* **16**:421-430 (1988)
16. K. Yamanouchi, M. Tanaka, Y. Tsuda, K. Yokoyama, S. Awazu, and Y. Kobayashi, *Chem. Pharm. Bull.* **33**:1221-1231 (1985)
17. R. Kaufman, in *Emulsions- A Fundamental and Practical Approach*, J. Sjoblom, Editor. Kluwer Academic Publishers:207-225 (1992)
18. K. Yokoyama, K. Yamanouchi, and R. Murashima, *Chem. Pharm. Bull.* **23**:1368-1373 (1975)

19. R.M. Mitten, A.R. Burgan, A. Hamblin, G. Yee, D.C. Long, and D.M. Long, *Biomat. Art. Cells Art. Organs* **16**:683-684 (1988)

**LUNG FUNCTIONS AFTER INTRAVENOUS OR
INTRAPERITONEAL ADMINISTRATION OF PERFLUOROOCXYL
BROMIDE (PFOB) OR PERFLUOROTRIBUTYLAMINE (FTBA)
EMULSIONS**

R.W. Millard and A.J. McGoron

Department of Pharmacology and Cell Biophysics
University of Cincinnati, Cincinnati, Ohio USA 45267-0575

ABSTRACT

The biomechanical and oxygen transfer functions of lungs of animals administered intravenous or intraperitoneal fluorocarbon emulsions containing either perfluorotributylamine or perfluorooctyl bromide 4 to 7 days earlier were tested in a porcine and a canine model. Lung fluorocarbon content was measured by ^{19}F NMR spectroscopy. The existence of fluorocarbon in the lung tissue produced no measurable effects on lung compliance variables *in vivo* or *ex vivo* nor on steady state oxygen transfer from air to blood over a wide range of inspired oxygen partial pressures.

INTRODUCTION

Fluorocarbon emulsions administered as blood substitutes or vascular imaging agents have intravascular residence times that are dose dependent and range from 10 to 24 hours and perhaps longer depending upon emulsion characteristics [1-3]. Disappearance from the blood pool occurs as the lipid coated fluorocarbon particles are snatched up by circulating and tissue resident cells, predominantly located in liver, spleen, bone marrow and lung. Particles in circulation may be acquired by tissues through pinocytosis into endothelial cells [4]. This is followed by transfer of fluorocarbon to tissue parenchymal cells and then to circulating

monocytes by phagocytosis[5]. Such phagocytic cells (e.g., Kupffer cells of the liver venous sinusoids) may serve to convey the fluorocarbon from the original tissue deposition site to distant tissues where they can adhere to the vascular (capillary or venous) circuits or invade the tissue proper to become permanent residents (e.g., interstitial neutrophils in the lung parenchyma).

In some species (e.g., swine), significant hemodynamic sequelae accompany intravascular administration of even small volumes of lipid-fluorocarbon emulsions [6]. Fluorocarbons administered in emulsion form have been demonstrated to distribute to all organs of the reticulo-endothelial system whether administered by intravascular or intraperitoneal routes [1,7]. As intraperitoneal administration of fluorocarbon-lipid emulsions is not accompanied by adverse hemodynamic responses we used this route in swine studies to "load" the lung with fluorocarbon. The transfer of fluorocarbon from the peritoneal space to the lung is postulated to follow either or both of two pathways; (1) slow lymphatic drainage from the peritoneal cavity into the blood stream with direct uptake by endothelial and phagocyte cells within the lung, and (2) transcapillary movement of emulsion particles across the abdominal microcirculation leading to initial liver sequestration of fluorocarbon and subsequent redistribution to the lung, spleen, etc.

The lung serves both as a repository and the major elimination site for administered fluorocarbons. Fluorocarbons have the potential, based on their physico-chemical properties, to dissolve large quantities of gases [8-10] and have been reported to cause alterations in lung anatomy [11]. Accordingly, we postulated that fluorocarbon containing lungs would exhibit biomechanical properties and gas exchange functions different from those of control normal lungs. We also considered the possibility that the lipid used to formulate the fluorocarbon emulsion might also contribute to any observed differences as intravenous administrations of fatty acids and lipid emulsions have been shown to reduce arterial oxygen tension in animal models [12,13] and in humans with adult respiratory distress syndrome [14]. Such differences in fluorocarbon lipid emulsion treated animals should be more evident in those receiving intravascular fluorocarbon emulsion administration.

MATERIALS AND METHODS

Beagle dogs (8-12 kg, n=4) were chronically instrumented with polyethylene catheters in the femoral artery and vein under ketamine (10 mg/kg,

i.m.) and sodium thiamylal (10 mg/kg, i.v.) anesthesia. Additional doses of sodium thiamylal were administered throughout the procedure as needed. The catheters were fed subcutaneously to the mid dorsal region and exited for subsequent administration of perfluorocarbon emulsion (FCE) and blood sampling. After a four day recovery period three animals were given 11g PFC/kg body weight perfluorooctyl bromide (PFOB, perflubron, Alliance Pharmaceutical Corp., San Diego, CA) as a 90 % w/v emulsion (Oxygent™HT)[15] i.v. while conscious over 30 min. The fourth dog was given an equal volume of normal saline.

Female farm raised swine (8-12 kg, n=6) were anesthetized with ketamine (10 mg/kg, i.m.) and sodium thiamylal (10 mg/kg, i.v.) with supplemental doses as required throughout the procedure. Warm (37 °C) emulsion containing 10 % w/v perfluorotributylamine (FTBA, Oxypherol-E.T., Alpha Therapeutics Corporation, Los Angeles, CA, n=5) or saline (n=2) was administered into the peritoneal cavity to avoid acute, transient cardiovascular responses. The animals were given a total dose of 11 g PFC/kg body weight and allowed to recover. Animals were conscious and ambulatory within an hour after administration.

Arterial blood PO₂ was measured 1,2, 3, 6, 24, 48, 72 and 168 hours after FCE (n=2) or saline (n=1) administration to unsedated beagles while breathing room air. Blood perfluorocarbon concentrations were measured statically using ¹⁹F NMR spectroscopy (360 MHz).

Four (pigs) to seven (beagles) days later each animal was anesthetized with sodium pentobarbital (25-35 mg/kg i.v.) and mechanically ventilated with room air at 10/min and 300 mL tidal volume. Inspired oxygen was varied from that of room air to 600 torr in the right lateral recumbent position as arterial blood oxygen level was monitored at steady state (5 min constant breathing). Oxygen supplementation was provided at the respirator inlet using carbogen (95%/5% : O₂/CO₂) at 1 L/min increments from zero (room air) to 5 L/min. Inspired (beagles) or expired (pigs) air (50 mL) and arterial blood (1 mL) samples were analyzed for oxygen partial pressure using a blood gas analyzer (Blood Micro System, Radiometer). At the end of each experiment the animal was euthanized with an overdose of sodium pentobarbital. Liver, lung and spleen was weighed and samples were stored at -20° C for later PFC tissue content measurement by ¹⁹F NMR spectroscopy [7].

In situ pulmonary biomechanical assessment was made in fully anesthetized animals by measurement of rate of pressure rise (inflation phase), rate of pressure fall (deflation phase) and peak airway pressure as tidal volume was varied by 100 mL steps from 150 to 700 to 150 mL at an ambient atmospheric end-expiratory

pressure. Tidal volume was delivered by a positive pressure oscillating mechanical respirator (Harvard Instruments, Millis, MA) at a constant ventilation rate of 10 breaths/min with an inspiration:expiration ratio of one. *Ex vivo* measurements were made in a similar fashion on one lung lobe placed in a non-confining plastic enclosure to evaluate the influence of the thorax and diaphragm on *in vivo* biomechanics.

RESULTS

Small changes in arterial blood PO₂ from baseline (pre dose) were observed after FCE or saline administration to beagles (Table 1). Arterial blood samples were obtained from 2 of 3 beagles receiving Oxygent™HT intravenously. An average of 30% of the perfluorooctyl bromide (perflubron, PFOB) administered i.v. was removed from the blood compartment within 1 hour. And after 3 days less than 25% of the original perfluorocarbon remained in the blood. By day 7 no perfluorooctyl bromide was detected by ¹⁹F NMR spectroscopy in the blood compartment. Visual inspection of blood samples subjected to centrifugation for hematocrit and fluorocrit were consistent with these findings.

Postmortem tissue analysis by ¹⁹F NMR spectroscopy revealed 0.042 ±0.015 (MEAN ±SEM) g PFOB/g tissue in beagle lungs and 0.097 ±0.010 g PFTA/g in pig lungs. No differences in the inspired or expired air to arterial blood PO₂ gradient was observed between FCE and saline treated animals. Regression equations of arterial blood PO₂ vs airway PO₂ between FCE and saline treated groups for each species reveal no significant changes between treatment and controls (Figures 1 and 2). There were no detectable amounts of perfluorocarbon in the blood of any animal at the time when this study of lung oxygen transfer function or biomechanics was conducted.

No changes in pulmonary mechanics were observed in either *in vivo* or *ex vivo* beagle lungs 7 days after i.v. administration of either Oxygent™HT or saline. Peak inflation pressure and the rate of pressure rise and fall as tidal volume was increased from 150 to 750 and back to 150 mL in *in vivo* lungs or during tidal volume changes from 5 to 30 to 5 mL/g lung tissue in *ex vivo* lung lobes were not different between PFOB and saline treated beagles.

DISCUSSION

In mechanically ventilated anesthetized beagles, FCE administered as Oxygent™HT intravenously 7 days earlier did not appear to affect steady state

TABLE I: Arterial blood PO₂ of conscious beagles breathing room air at baseline (B) and up to 168 hours after Oxygent™HT (F) or saline (S) infusion.

Beagle #	B	1	2	3	6	24	48	72	168
Beagle #1 (F)	67	81	78	81	71	82	82	79	65
Beagle #2 (F)	84	77	91	84	84	84	76	74	N/A
Beagle #3 (S)	74	64	75	82	85	71	63	79	58

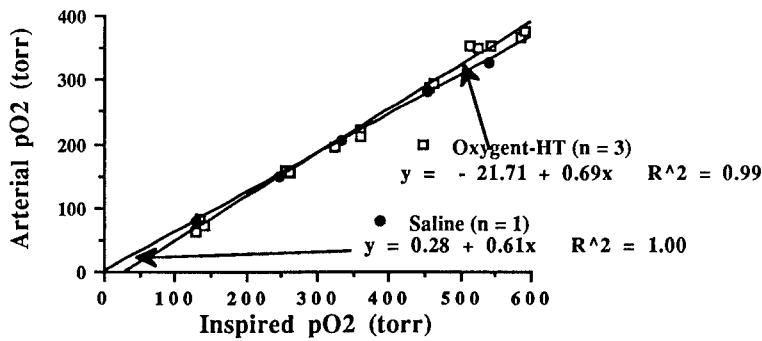

FIGURE 1: Arterial blood PO₂ vs inspired PO₂ seven days after 11 g PFOB (administered as Oxygent™-H.T.) or 12 mL saline per kg body weight i.p. to beagles.

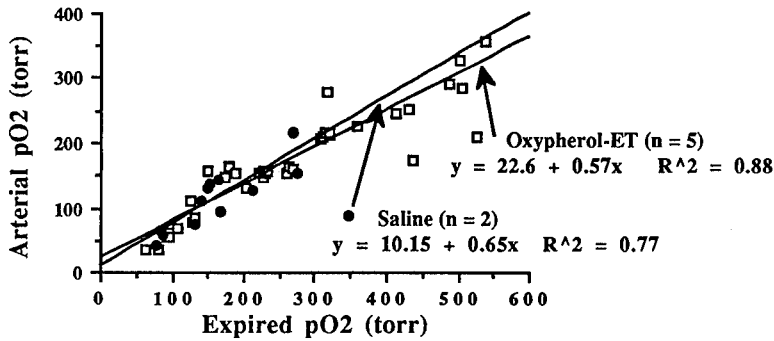

FIGURE 2: Arterial blood PO₂ vs expired PO₂ four days after 11 g FTBA (as Oxypherol-E.T.) or 50 mL saline per kg body weight i.v. to pigs.

oxygen transfer from the lungs to the arterial blood over the range of inspired PO_2 from 120 to 600 torr. There were no consistent acute effects of OxygentTMHT on arterial blood PO_2 of dogs during spontaneous room air breathing. In dogs with low hematocrit (Hct=10-12%) 100% oxygen breathing was reported previously to increase mixed venous PO_2 significantly after 6.3 g PFOB/kg body weight i.v. [16] In severely anemic (Hct<7%) newborn sheep treated with a FTBA emulsion to achieve a higher fluorocrit (Fct=18%) 100% oxygen breathing increased arterial PO_2 from 317 to 419 torr [17].

In the present study there was no perfluorocarbon was detected in the blood by high field specific ^{19}F -NMR spectroscopy at the time the physiological studies were performed. Fluorocarbon quantities measured in lung tissue were sufficient for in vivo measurement of tissue oxygen levels by ^{19}F -NMR imaging methods [7, 18]. When the animals were mechanically ventilated neither enhancement nor inhibition of air to blood oxygen transfer across the lung at steady-state ventilation condition could be inferred from the data. In the dog and pig administered perfluorotributylamine or perfluorooctyl bromide as emulsions, there appears to be neither benefit nor detriment to oxygen transfer by lungs confirmed to contain tissue bound perfluorocarbons. We were unable to identify any significant deviation from the norm of any pulmonary biomechanical variable (i.e., peak inflation pressure over a range of inflation volumes, inflation and deflation pressure-volume curves) measured in the lungs *in vivo* or *ex vivo*. This observation and that where we found no effect on steady state oxygen transfer from air to blood are clearly drawn from a small sample set and from two species, two routes of administration and two different fluorocarbons. Nevertheless, our results do not appear the implications of the observations reported by Clark et al. [11] in rabbits where lung deflation was impaired after intravenous fluorocarbon emulsion administration or intratracheal instillation of neat fluorocarbon liquid. We believe that our study allows examination of the role of both lung fluorocarbon and emulsion lipid on important lung functions. We can not refute observations in rabbits noted above as this species may be uniquely sensitive to fluorocarbon and emulsions thereof administration. However, we do assert that, 4 and 7 days after administration of fluorocarbon emulsions by different routes and doses in both the canine and porcine model, biomechanical and oxygen transfer functions of lungs containing fluorocarbon were essentially normal.

ACKNOWLEDGEMENTS

This study was conducted with the support of a grants from the National Institutes of Health (HL-22619-Core I and HL-45243). The fluorocarbon emulsion containing perfluorooctyl bromide (Oxygent™ HT) was kindly provided by Alliance Pharmaceutical Corp., San Diego, CA. A.J. McGoron is a Postdoctoral Fellow supported on an NIH Training Grant in cardiovascular sciences (T32-HL-07382).

REFERENCES

1. K. Yokoyama, K. Yamanouchi, and R. Murashima, *Chem. Pharm. Bull.* 23:1368-1373 (1975)
2. J.G. Riess, In Blood Substitutes and Oxygen Carriers, T.M.S. Chang (ed) Marcel Dekker, New York, 24-43, (1993)
3. N.S. Faithfull, In Blood Sunstitutes and Oxygen Carriers, T.M.S. Chang(ed) Marcel Dekker, New York, 569-576 (1993)
4. J.W. Ryan and U.S. Ryan, *Fed. Proc.* 13:2683-2691 (1977)
5. F.D. Kolodgie, A.K. Dawson, M.B. Forman, and R. Virmani, *Virchows Arch.[Cell Pathol]*. 50:119-134 (1985)
6. Y. Hermoni, R. Millard, and M. Gabel, *Fed. Proc.* 46:519 (1987)
7. R.G. Pratt, S.R. Thomas, R.W. Millard, R.C. Samaratunga, and M.H. Naseem, *Biomat., Art. Cells & Immob. Biotech.* 20:921-924 (1992)
8. E. Wesseler, R. Iltis, and L. Clark, *J. Fluorine Chem.* 9:137-146 (1977)
9. J.G. Riess and M. Le Blanc, *Pure Appl. Chem.* 54:2383-2406 (1982)
10. G.L. Pollack, R.P. Kennan, and G.T. Holm, *Biomat. Art. Cells & Immob. Biotech.* 20:836-839 (1992)
11. L.C. Clark Jr., R.E. Hoffman, and S.L. Davis, *Biomat., Art. Cells & Immob. Biotech.* 20(2-4):1085-1099 (1992)
12. C. Chiang, C. Shen, and K. Hsu, *Crit. Care Med.* 18:419-422 (1990)
13. E. Halden, U. Hedstrand, and K. Torsner, *Acta. Anesth. Scand.* 26:121-125 (1982)
14. B.Venus, R.A.Snith, C.Patel, and E. Sandoval, *Chest.* 95:1278-1281 (1989)
15. J.G. Riess, J.L. Dalfors, G.K. hanna, D.H. Klein, M.-P. Krafft, T.J. Pelura and E.G. Schutt, *Biomat., Art. Cells and Immob. Biotech.* 20:839-842 (1992)
16. P.E. Keipert, N.S. Faithfull and R.M. Peters, *FASEB J.* 6:A1350 (1992)

17. H.G. Breuninger, M.R. Wolfson, S.D. Rubenstein and T.H. Shaffer, *J. Develop. Physiol.* 14:283-289 (1990)
18. S.R. Thomas, R.G. Pratt, Y. Shiferaw and R.W. Millard, *Soc. Magn. Reson. Med. Abstracts* 4311 (1992)

EFFECT OF PERFLUORO-CHEMICALS ON LIVER DETOXICATION
ENZYMES

V.V. Obraztsov and D.G. Shekhtman
Institute of Cell Biophysics
Russian Academy of Sciences
Pushchino, Russia

The purpose of the present review is to report on studies by Russian scientists dealing with the induction of liver microsomal enzymes by perfluorochemicals (PFCs). The results of these investigations have mainly been published in Russian journals and thus, are not widely available.

Though investigations on the interaction of microsomal cytochrome P-450 with fluorocarbons were started more than 20 years ago, there have not been many attempts to study the problem [1-4]. The question of the effect of PFCs upon the activity of liver cytochrome P-450-dependent monooxygenase system began to draw the attention of researchers, after the phenomenon of cytochrome P-450 induction in animal's liver following PFC administration had been observed [5]. The induction of enzymes of the cytochrome P-450-dependent monooxygenase system after injection of various xenobiotics is a well-studied process. Nonetheless, the induction of the cytochrome enzymes by compounds, biological inertness of which has been agreed-upon, turned out to be rather unexpected. A sharp increase (2-4-fold) of the cytochrome P-450 content in liver microsomal membranes was observed a few days after fluorocarbon injection in animals. Later the above results were reproduced in a number of laboratories [6-10], and to date the phenomenon has been generally recognized.

Cytochrome P-450 induction by PFCs appears to have two important aspects. One of them refers to physico-chemical properties of fluorocarbon inducers [11]. Only PFCs of high solubility, both in lipids and water, have been found to be able to induce cytochrome P-450 in animal's liver. Since the physico-chemical

properties of PFCs appear to be related to each other, an enhancement of fluorocarbon solubility in water and lipids, caused by a diminution in molecular weight, increases inevitably the vapor pressure of PFCs. Vapor pressure is critical if PFCs are injected intravenously: the pressure increase exceeding 30 mm Hg causes mortality as a result of gas embolia. Thus, a number of fluorocarbon inducers of cytochrome P-450 are shown to be limited by the molecules with the amount of atoms close to C9-C12 and F16-F21, and molecular weight close to 400-550. A presence of heteroatoms in a fluorocarbon molecule, as well as its structural properties, are of no significance for the determination of cytochrome inductive capacities of PFCs. It is the PFCs of this range that are found to be rapidly excreted from organism and are used for preparation of blood substituting emulsions.

A more important problem is concerned with the forms of cytochrome P-450 synthesizing in liver in response to fluorocarbon injection. Two groups are known to be distinguished among xenobiotics-inducers [12]. Barbiturates and other compounds causing a so-called phenobarbital (PB) type of induction and reinforcing the detoxicating effect of the liver monooxygenase system, belong to the first group. The second group includes polycyclic aromatic carbohydrates, dioxines, polychlorinated biphenyls and other compounds producing a methylcholantrene type of induction. In the latter case the monooxygenase system involved in the metabolism of xenobiotics, changes them into products possessing toxic, cancerogenic and mutagenic properties. An extensive investigation of the cytochrome P-450 forms synthesizing after injection of fluorocarbons, in particular perfluorodecalin (PFD), has been undertaken.

PFD induces in rat liver microsomes the cytochrome P-450 forms whose immunological properties and substrate specificity correspond to those of the phenobarbital-type cytochrome P-450. Moreover, the cytochrome P-450 forms isolated from liver of PFD- and PB-treated animals revealed their similarity in a number of properties: chromatographic behavior on DEAE-Sephacel column, molecular weight determined by SDS-electrophoresis in PAAG and peptide mapping [13-15]. It should particularly be emphasized, that unlike polychlorinated biphenyls, having a structure similar to that of PFD, the latter did not induce even traces of methylcholantrene forms of cytochrome P-450 [16]. The results described are an obvious confirmation of the fact that fluorocarbon blood substitutes do not possess cancerogenic and mutagenic capacities.

The absence of induction of the cytochrome P-450 methylcholantrene forms nonetheless does not withdraw the question whether the induction of liver cytochrome P-450 is to be considered as a side effect of the PFC-based blood substitutes. An analysis of peculiarities of fluorocarbon - microsomal cytochrome P-450 interaction shows the following cytochrome P-450-dependent side-effects of fluorocarbon blood substitute administration which might exist:

1. PFCs, uncoupling microsomal hydroxylation, increase the rate of NADPH oxidation [2]. An exhaustion of NADPH pool revealed in particular under perfusion of isolated liver by a substrate of monooxygenase, aminopyrine has been shown to inhibit gluconeogenesis and lipogenesis [17].

2. PFCs change the stoichiometry of oxidase reactions catalyzed by microsomal cytochrome P-450 [18].

3. Prolonged induction of a phenobarbital-type liver monooxygenase can lead to considerable changes in a spectrum and a concentration of some physiologically-important endogenous compounds which are metabolized by cytochrome P-450.

4. The induction of liver monooxygenase after fluorocarbon injection leads to a disconnection of the xenobiotic biotransformation process, the phase I of which is monooxygenase reactions, and phase II - conjugation reactions. In this case, the increase of the amount of reactive intermediates formed to a level which can not be effectively handled by the deactivating conjugation reactions resulting in adverse effects [19].

An experimental analysis of the possible cytochrome P-450-dependent side effects, mentioned above, has been carried out in a number of works. It has been shown, that under PFD injection to animals a concentration of NADH and NADPH in liver as well as that of glucose in blood, remains constant throughout the induction [20]. During uncoupling microsomal hydroxylation by PFCs (the authors [18] studied perfluorohexene, whose binding with microsomal cytochrome P-450 is similar to that of PFD [20]), no accumulation of any active and potentially dangerous products, namely, hydrogen peroxide and superoxide radicals, has been observed. Reducing equivalents of NADPH in microsomal system, uncoupled by fluorocarbon, were presumably spent for a production of water. If fluorocarbon is injected, no disconnection of reactions in phases I and II of xenobiotic biotransformation has been found since the induction of monooxygenase enzymes is accompanied by an activation of the main conjugation enzymes: microsomal glutathione S-transferase and UDP-glucuronosyl transferase [21]. The increase in

the activities of microsomal GT-ST and UDP-GT, being in spatial closeness to cytochrome P450, is a favorable factor which makes it possible to compensate the high rate of xenobiotic oxidation by cytochrome P-450 upon increasing the rate of conjugation of active metabolites with endogenic glutathione and UDP-glucuronic acid.

The problem concerning the effect of the liver microsomal enzyme induction upon the metabolism of endogenic substrates (including fatty acids, sterols, prostaglandins, bilirubin, etc) remains still rather complex for experimental investigation. It is also complicated by the capacity of fluorocarbons, in particular PFD, to competitively inhibit binding of substrates to cytochrome P-450 and to decrease the rates of monooxygenase reactions. Thus, the simultaneous inhibition and induction of monooxygenase enzymes after administration of PFCs to animals can cause considerable uncertainty concerning the rates of various monooxygenase reactions [22].

Thus, the absence of any obvious causes for the development of the adverse effects due to the cytochrome P-450 induction, the results of observations in the animals whose cytochrome P-450 were induced for a long time by PFCs [6,8], and lastly an extensive experience of fluorocarbon blood substitutes both experimentally and in clinical medicine, indicates that the induction of liver phenobarbital-type cytochrome P-450 is an adaptive rather than a pathological reaction of a healthy organism to the presence of a fluorocarbon xenobiotic. However, these findings suggest the use of fluorocarbon blood substitutes would be contra-indicated in patients with liver poisoning or liver pathology.

Although the idea of a pharmacologic implication of liver microsomal enzyme induction was advanced by Conney 25 years ago [23], only a few attempts have been made to study this further [24]. The main obstacle has been the fact that both the usual carbohydrate xenobiotic inducers and the products of their hydroxylation are physiologically active, i.e. besides inducing microsomal enzymes they cause narcotic sleep, have an unfavourable therapeutic effect and may prove to be poisons (in particular, carcinogenic). In this respect PFCs are the most neutral compounds meeting fully the requirements of a "non-drug" xenobiotic inducer. To date a few experimental studies have been undertaken to use the fluorocarbon induction of microsomal enzymes for treatment and prophylactic purposes.

Thus, a preliminary administration of PFD-containing emulsion effectively increased the protective action of antidotes (atropine + dipyroxime) increasing the resistance of the rats by approximately 20-fold of organophosphorous pesticides [25]. A similar positive result was obtained when rats were poisoned with sodium fluoroacetate [26]. The induction of microsomal enzymes after i.p. injection of PFD to animals was also found to weaken an allergic reaction of the organism. PFD administration to guinea pigs and mice both before sensitization and during the development of sensitization reduced the degree of hypersensitive reactions of immediate (to hen egg protein) and delayed (to sheep red blood cells) types [27]. In addition, the liver microsomal enzyme induction by PFCs increased anticancer action of some drugs.

Treatment of mice with PFD (0.5 ml per one mice) produced a 2.5-fold increase in the antineoplastic activity of ftorafur [5-fluoro-1-(tetrahydro-2-furyl)uracil] determined by a reduction of leukocytes and of hepatoma H-2-73 weight as well as Lewis lung carcinoma resistance to ftorafur alone [28].

The experimental data amassed about the PFC effect upon liver microsomal enzymes, as well as a wealth of experience on cytochrome P-450 induction by other compounds, suggests some positive sequels resulting from fluorocarbon blood substitute application in clinic medicine. Assuming that the main features of the microsomal enzyme induction process after PFC administration to animals can be extrapolated to humans, the following effects may be expected:

1. PFC emulsions inhibit temporarily the detoxication function of liver before the induction occurs, thus worsening a state of a patient suffering acute toxicosis.
2. After development of the liver microsomal enzyme induction, certain changes, both in pharmacokinetics and pharmacodynamics of some drugs, should be expected, requiring changes in the traditional dosage.
3. Fluorocarbon blood substitutes can potentate an activity of the drugs, whose pharmacologic effects are related to the products of their hydroxylation by microsomal enzymes. Depending on the specific clinical situation and the type of the drug used, both positive and negative effects of PFC application might be expected.

Nonetheless, when analyzing possible sequels from human liver microsomal enzyme induction caused by fluorocarbon blood substitute application, it should be kept in mind, that the cytochrome P-450-dependent monooxygenase system is rather plastic. A high variability (34-fold) of cytochrome P-450 content is known

to be the case in liver of a healthy human population [29], and 2-3-fold deviation of the activity of the human liver monooxygenase system activity from the average value, as estimated by an antipyrine test in healthy humans, is observed [30]. On the other hand, monooxygenase system activity as well as its inducibility by xenobiotics in humans is dependent on the individual and is genetically determined, (depends on sex, age, nutrition regime, organism immune status etc.) [31]. Taking these facts into account, it can be concluded that an increase of phenobarbital-type cytochrome P-450 in the human organism following fluorocarbon blood substitute administration may not essentially affect a patient's state. The generally positive experience with experimental and clinical applications of fluorocarbon blood substitutes confirms this assumption.

Obviously, the investigation of the PFC - microsomal cytochrome P-450 interaction is of great importance for the evaluation of side-effects of fluorocarbon blood substitutes. Furthermore, fluorocarbon emulsions are of interest for use as drugs for the activation of liver detoxic function.

REFERENCES

1. V.Ullrich, H. Diehl. *Europ. J. Biochem.*, 20, 509-512 (1971).
2. H. Staudt, F. Lichtenberger, V. Ullrich. *Europ. J. Biochem.*, 46, 99-104 (1974).
3. R.P. Geyer. *Proc. Int. Symp. Oxygen Carrying Colloidal Blood Substitutes* (Mains. 1981), Munich.: W.Zuckschwerdt Verlag, 19-29 (1982).
4. N.A. Brown, K.J. Netter, J.W. Bridges. *Biochem. Pharmacol.*, 28, 2850-2852 (1989).
5. V.V. Obraztsov, D.G. Shekhtman, G.R. Sologub, F.F. Beloyartsev. *Biokhimiya*, 50, 1220-1224 (1985).
6. T.G. Khlopushina, I.E. Kovalev, E.M. Lysenkova. *Biokhimiya*, 51, 664-667 (1986).
7. R.P. Shrewsbury, S.G. White, G.M. Pollack, W.A. Wargin. *J. Pharm. Pharmacol.*, 38, 883-887 (1986).
8. R. Huang, D.J. Cooper, H.A. Sloviter. *Biochem. Pharmacol.*, 36, 4341-4345, (1987).
9. N.V. Adrianov, A.I. Archakov, M. Zigler. *Bull. eksperiment. biologii mediciny*, 8, 164-166 (1989).

10. F.H. Armstrong, K.C. Lowe. *Comp. Biochem. Physiol.*, 94C, 345-349 (1989).
11. V.V. Obratsov, D.G. Shekhtman, A.N. Sklifas, K.N. Makarov. *Biokhimiya*, 53, 613-619 (1988).
12. V.V. Mishin, V.V. Lyakhovich. *The Multiplicity of Cytochrome P-450 Forms*. (in Russian), 71-142, "Nauka", Novosibirsk.
13. A.Yu. Grishanova, V.V. Obratsov, D.G. Shekhtman, V.V. Lyakhovich. *Biokhimiya*, 52, 1138-1147 (1987).
14. A.Yu. Grishanova, N.I. Gutkina, V.M. Mishin. *Biokhimiya*, 53, 368-376 (1988).
15. V.M. Mishin, V.V. Obratsov, A.Yu. Grishanova, N.I. Gutkina, D.G. Shekhtman, O.G. Khatsenko, V.V. Lyakhovich. *Chem.-Biol. Interactions*, 72, 143-155 (1989).
16. V.V. Obratsov, D.G. Shekhtman, A.Yu. Grishanova, V.M. Mishin. *Biofizika*, 34, 146-147 (1989).
17. R. Scholz, W. Hansen, R.G. Thurman. *Europ. J. Biochem.*, 38, 64-72 (1973).
18. A.A. Zhukov, A.I. Archakov. *Biokhimiya*, 50, 1939-1952 (1985).
19. G. Ioannides. *Biochem. Soc. Trans.*, 18, 32-34 (1990).
20. V.V. Obratsov, A. Sklifas, E. Maevskii, D. Shekhtman, N. Kukushkin. *Proc. 7-th Int. Conf. on Biochemistry and Biophysics of Cytochrome P-450*. A.I. Archakov, G.I. Bachmanova (Eds.), INCO-TNC, Moscow, 597-600 (1992).
21. E.V. Kalinina, V.V. Obratsov, D.G. Shekhtman, O.V. Gudkova, N.I. Kukushkin, A.N. Saprin. *Biochem. International*, 24, 543-548 (1991).
22. V.V. Obratsov, A.Yu. Grishanova, O.V. Gudkova, D.G. Shekhtman. *Biokhimiya*, 57, 1011-1020 (1992).
23. A.H. Conney. *Pharmacol. Rev.*, 19, 317-366 (1967).
24. S. Szeberenyi, E. Palosi, L. Szporny. *Arzneim.-Forsch.*, 28, 663-668 (1978).
25. G.M. Mikhailov, A.A. Varykhanov, L.A. Omarova, V.E. Verovskii, A.A. Kolchin, V.V. Obratsov. *Farmacol. Toksikol.*, 53, No.4, 60-62 (1990).

26. G.M. Mikhailov, A.A. Varykhanov, A.A. Kolchin, B.N. Filatov. Proc. 7-th Int. Conf. on Biochemistry and Biophysics of Cytochrome P-450. A.I. Archakov, G.I. Bachmanova (Eds.), INCO-TNC, Moscow, 573-576 (1992).
27. T.G. Khlopushina, A.V. Krinskaya, I.N. Marokko, I.E. Kovalev. *Farmacol. Toksikol.*, 51, No.4, 86-87 (1988).
28. T.G. Khlopushina, A.V. Krinskaya, V.M. Bukhman, V.P. Zherdev, A.V. Valdman. *Bull. eksperiment. biol. mediciny.*, 113, No.1, 35-38 (1991).
29. B. Davis. *Ann. N.Y. Acad. Sci.*, 21, 404-428 (1964).
30. P.E. Thomas, L.M. Reik, D.E. Ryan, V. Levin. *J. Biol.Chem.*, 25, 1044-1052 (1981).
31. *Mammalian Cytochromes P-450*. F.P. Guengerich (ed.), CRC Press, Boca Raton, Florida 207 (1987).

**MIXED FLUOROCARBON/HYDROCARBON MOLECULAR DOWELS
HELP PROTECT CONCENTRATED FLUOROCARBON EMULSIONS
WITH LARGE SIZE DROPLETS AGAINST COALESCENCE**

C. Cornéus, M. P. Krafft and J. G. Riess.

Unité de Chimie Moléculaire, associée au CNRS

Faculté des Sciences

Université de Nice-Sophia Antipolis

06108 Nice Cedex 2, France

ABSTRACT : Mixed fluorocarbon/hydrocarbon amphiphiles, the so-called molecular dowels, have previously been reported to strongly stabilize concentrated (90% w/v, i.e. 47% w/v) submicronic size perfluorooctyl bromide emulsions emulsified by egg yolk phospholipids. The dowel molecules, used in equimolar amounts with phospholipids, enable the preparation of emulsions with large-sized particles which are impossible to obtain with phospholipids alone. We report here that molecular dowels (C₆F₁₃C₁₀H₂₁, F6H10) also hinder droplet coalescence induced by mechanical stress in sterilized emulsions with average particle sizes ranging from *ca* 1 to 16 μ m. In contrast, the addition of equimolar amounts of perfluorodecyl bromide was found to have little influence on these emulsions' resistance to mechanical stress. This is consistent with the view that mixed fluorocarbon/hydrocarbon dowels are held in the interfacial film and reinforce its cohesion with the fluorocarbon phase.

INTRODUCTION

One key to further development of fluorocarbon emulsions is the optimal adjustment of their physico-chemical and biological properties, i.e. average particle size, viscosity, biodistribution, in vivo recognition, etc, to the specific requirements of each therapeutic application [1].

Stability upon transport and storage is a decisive condition for the convenient use of these tailor-made emulsions. It has been shown [2] that highly concentrated submicronic fluorocarbon emulsions coarsen through molecular diffusion (transcondensation) of the fluorocarbon, which arises from its low but nevertheless finite solubility in the water phase. As a result, large particles grow at the expense of smaller ones [3]. For sufficiently large particles, coalescence starts prevailing as the main degradation process [4]. These two mechanisms result in an irreversible evolution of average droplet size and size distribution.

Different approaches to fluorocarbon emulsion stabilization have been used [5]. One involves the addition to the fluorocarbon of an additive which is more insoluble in the aqueous phase than the fluorocarbon itself, i. e. a fluorocarbon with a higher boiling point. The solubility and vapour pressure of the dispersed fluorocarbon in the continuous phase are then decreased, and the emulsion is protected against molecular diffusion [6].

A more recently developed concept for emulsion stabilization involves the use of an equimolar association of phospholipids and of a mixed fluorocarbon/hydrocarbon amphiphile [5]. The latter acts like a molecular dowel between the phospholipids' fatty acid chains and the fluorocarbon. Strong stabilization of submicronic emulsions has been observed, with essentially no growth of the average particle size after the annealing period, even when the emulsions were stored for 9 months at 40°C [7,8]. We have also reported that molecular dowels allow the preparation of concentrated stable perfluorooctyl bromide (perflubron) emulsions with efficient control of their average particle sizes over a wide range of sizes (from *ca* 0.1 to 16 µm post-sterilization) [8]. The large particle emulsions (> *ca* 3 µm) were impossible to obtain using phospholipids alone, indicating the cohesive effect of the mixed fluorocarbon/hydrocarbon amphiphiles between the phospholipid membrane and the fluorocarbon droplet.

Our objective in this work was to investigate whether molecular dowels also improve the resistance of fluorocarbon emulsions against accelerated coalescence and to compare any observed effect with that obtained by adding a heavier fluorocarbon. Perfluorooctyl bromide (perflubron) was selected as the fluorocarbon to be emulsified, C₆F₁₃C₁₀H₂₁ (F6H10) as the molecular dowel [9], and perfluorodecyl bromide (C₁₀F₂₁Br), a higher homologue of perflubron, as the heavy fluorocarbon. Similarly sized perflubron emulsions were prepared using EYP or equimolar mixtures of EYP/F6H10 or of EYP/C₁₀F₂₁Br. A mechanical

stress test was used to assess the resistance of the emulsions to coalescence. The amount of free (unemulsified) perflubron present after vigorous shaking and centrifugation was measured. The improved resistance to coalescence observed for the dowel-based emulsions will be discussed with respect to the role of the dowel molecule on the structuration of the fluorocarbon/water interface.

MATERIALS AND METHODS

Perfluorooctyl bromide ($C_8F_{17}Br$, perflubron, bp $140.5^\circ C$) was supplied by Hoescht (Germany). The dowel molecule used ($C_6F_{13}C_{10}H_{21}$, F6H10) was synthesized and purified in the Laboratory (98% purity, assessed by GC) according to [10]. Perfluorodecyl bromide ($C_{10}F_{21}Br$, bp $198^\circ C$) was supplied by Atochem (France). Injectable grade egg yolk phospholipids (EYP Lipoid 80) was purchased from Lipoid KG (Germany).

Preparation of the emulsions

The ingredients were premixed using an Ultra-Turrax mixer model T50 (Ika-Labortechnik, Germany) fitted with the G45MF probe. Emulsification was achieved using a Rannie homogenizer Mini-Lab type 8.30H (APV-Rannie, Denmark), using the ceramic cylinder configuration. Sterilization was achieved under standard conditions (15 min, $121^\circ C$, 15 psi). Average particle size and particle size distribution histograms were measured by photosedimentation (Horiba analyzer, model Capa-700, Japan) after sterilization ($\pm 10\%$).

The elaboration of the EYP-based concentrated (90%w/v, *i.e.* 47% v/v) emulsions of perflubron, stabilized or not by the dowel molecule, was achieved according to [8]. For the preparation of the $C_{10}F_{21}Br$ -based emulsions, equimolar amounts of $C_{10}F_{21}Br$ with respect to the phospholipids, *i.e.* 0.12 to 0.31% w/v, were added to the perflubron phase prior to premixing.

Accelerated coalescence

The sterilized emulsions were submitted to a mechanical stress test, using a to and fro shaker (amplitude 30 mm) model HS 501 D (Ika-Labortechnik, Germany). The 7 mL-size vials (constant head-space 1.4 mL) were attached parallel to the direction of the throw and allowed to shake for the appropriate amount of time (15-60 min) at a frequency of 200 strokes/minute. The totality of the sample was then poured into a graduated centrifuge tube and the vial carefully rinsed with water. The stressed emulsion was centrifuged ($1500 \text{ rev. min}^{-1}$ for 10 min, room temperature), after which the volume of free fluorocarbon present was measured. As no annealing

period was observed in the ageing of large-sized ($> 1\mu\text{m}$) emulsions, the test was undertaken on freshly sterilized emulsions [8].

RESULTS AND DISCUSSION

Effect of molecular dowels or perfluorodecyl bromide on the emulsions' preparation.

The preparation of three series of concentrated (90% w/v) heat-sterilized perflubron emulsions was attempted 1) with phospholipids alone in concentrations ranging from 0.05 to 0.40% w/v, 2) with equimolar amounts of phospholipids (concentrations as above) and of the F6H10 dowel molecule (0.03 to 0.24% w/v) and 3) with equimolar amounts of phospholipids (concentrations as above) and of $\text{C}_{10}\text{F}_{21}\text{Br}$ (0.04 to 0.31% w/v). Table I shows the formulations of the various emulsions prepared and the average particle sizes measured after sterilization.

As reported earlier [8], emulsions with average droplet sizes larger than $ca\ 3.1 \pm 0.3\ \mu\text{m}$ (with EYP = 0.20%) cannot be prepared with EYP alone. It is now shown that the addition of $\text{C}_{10}\text{F}_{21}\text{Br}$ allows the preparation of slightly larger droplets (i.e. $4.7 \pm 0.5\ \mu\text{m}$ with EYP/ $\text{C}_{10}\text{F}_{21}\text{Br}$ = 0.15/0.12%). On the other hand, particles as large as $16 \pm 1.6\ \mu\text{m}$ with as low as 0.05% of phospholipids could only be prepared with the dowel molecule (0.03%).

The fact that the dowel molecules enable the preparation of emulsions with much larger droplet sizes with 3-times less surfactant, indicates that the dowel molecule has a co-surfactive effect and participates to the structuring of the phospholipid membrane. The evaluation of the preparation of even larger particle size emulsions is in progress.

Resistance to mechanical stress-induced coalescence

A severe mechanical stress test was applied to the freshly sterilized emulsions prepared with EYP/F6H10, EYP/ $\text{C}_{10}\text{F}_{21}\text{Br}$ and EYP alone, in order to induce coalescence of the fluorocarbon droplets. The variation of the amount of free perflubron present after a 45-min shaking period is plotted as a function of the emulsions' average particle size in Figure 1.

A linear variation is observed ($r^2 > 0.95$), indicating lower resistance to the accelerated coalescence test as average particle size is increased. It can be seen that the dowel-stabilized emulsions, from $ca\ 1.1$ to $16\ \mu\text{m}$, resist stress significantly better than both the emulsions prepared with EYP alone and those prepared with $\text{C}_{10}\text{F}_{21}\text{Br}$, over the domain of sizes which can be prepared, i.e. respectively from

TABLE I : Description of the differently sized perflubron (90% w/v) emulsions.

EMULSION FORMULATIONS			AVERAGE PARTICLE SIZE (μm)		
EYP % (w/v)	F6H10 % (w/v)	C ₁₀ F ₂₁ Br % (w/v)	EYP- based emulsions	EYP/F6H10-based emulsions	EYP/C ₁₀ F ₂₁ Br- based emulsions
0.40	0.24	0.32	1.22±0.12	1.12±0.11	1.10±0.11
0.30	0.16	0.24	2.3±0.2	2.0±0.2	2.1±0.2
0.20	0.12	0.16	3.1±0.3	2.8±0.3	2.7±0.3
0.17	0.10	0.13	*	3.9±0.4	4.1±0.4
0.15	0.09	0.12	*	4.7±0.5	4.7±0.5
0.10	0.06	0.08	*	6.1±0.6	*
0.07	0.04	0.06	*	10±1.0	*
0.05	0.03	0.04	*	16±1.6	*

* No stable emulsion can be prepared.

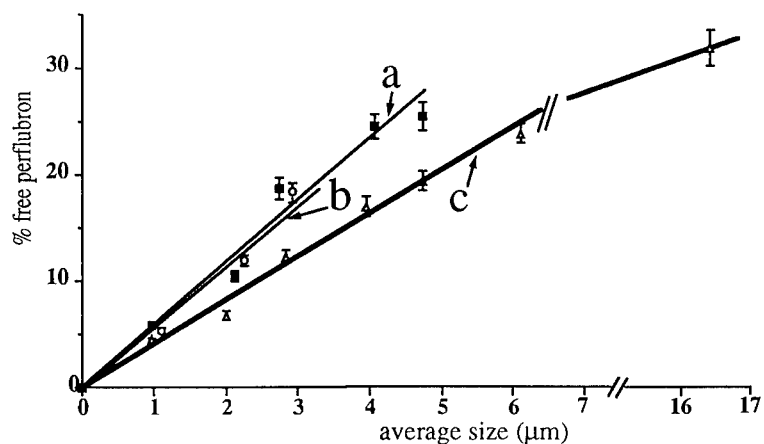

FIGURE 1 : Amounts of free perflubron present after 45 minutes of shaking (200 strokes/min) as a function of the average particle sizes of freshly sterilized emulsions prepared with a) EYP alone, b) equimolar amounts of EYP and F6H10, c) equimolar amounts of EYP and C₁₀F₂₁Br.

ca 1.2 to 3.1 μm and from ca 1.1 to 4.7 μm . It is noteworthy that even if emulsions with slightly larger sizes than those prepared using EYP alone can be prepared using the EYP/C₁₀F₂₁Br mixture, no significant stabilization effect has been noted with regards to the larger droplets' coalescence.

These results clearly indicate that mixed fluorocarbon/hydrocarbon amphiphiles improve the mechanical properties of the fluorocarbon/water interfacial film by enhancing the cohesion of the lipid membrane around the fluorocarbon droplets. This result is supported by the comparison with C₁₀F₂₁Br, which is known to stabilize the emulsions by reducing the rate of molecular diffusion. Stabilization by using molecular dowels can thus be considered to be more efficient, since these molecules are able to counteract both molecular diffusion and coalescence.

ACKNOWLEDGEMENTS : We wish to thank the Centre National de la Recherche Scientifique and Applications et Transferts de Technologies Avancées (C. C.) for their support.

REFERENCES

- [1] J.G. Riess, *Vox sanguinis*, **61**, 225-239 (1991).
- [2] L. Trevino, L. Sole Violan, P. Daumur, B. Devallez, M. Postel, J. G. Riess, *New J. Chem.*, XXX (1993)
- [3] L. M. Skinner and J. R. Sambles, *Aerosol Science*, **3**, 199-210 (1972).
- [4] T. F. Tadros, B. Vincent in "*Encyclopedia of emulsion technology*", P. Becher (ed) vol 1, p.129, M. Dekker, New York, 1983.
- [5] J.G. Riess, M. Postel, *Biomat., Art. Cells, Immob. Biotech.*, **20**, 819-830 (1992)
- [6] W.I. Higushi, J. Misra, *J. Pharm. Sci.*, **51**, 459-466 (1962).
S. S. Davis, H. P. Round, T. S. Purewall, *J. Colloid Interf. Sci.*, **80**, 508-511 (1981)
- [7] J.G. Riess, L. Sole-Violan and M. Postel, *J. Disp. Sci. Technol.*, **13**, 349-355 (1992).
J.G. Riess, C. Cornélus, R. Follana, M.P. Krafft, A.M. Mahé, M. Postel, L. Zarif, in "*Oxygen Transport to Tissues XV*", P. Vaupel (ed), Plenum Press Corp., New-York, xxx 1993.
- [8] C. Cornelus, M. P. Krafft, J. G. Riess, "Improved control over particle sizes and stability of concentrated fluorocarbon emulsions by using mixed fluorocarbon/hydrocarbon molecular dowels", *These Proceedings*.
- [9] L. Zarif, M. Postel, B. Septe, J.G. Riess, A.M. Mahé, R. Follana, *J. Pharm. Res.*, XXX (1993).
- [10] G. V. D. Tiers, *J. Org. Chem.*, **27**, 2261-2262 (1962).
N. O. Brace, *J. Org. Chem.*, **37**, 2429-2436 (1972).

**AMPHIPHILIC SUGAR PHOSPHATES WITH SINGLE OR
DOUBLE PERFLUOROALKYLATED HYDROPHOBIC CHAINS
FOR USE IN OXYGEN AND DRUG DELIVERY SYSTEMS**

F. Guillod, J. Greiner, A. Milius and J. G. Riess

Université de Nice-Sophia Antipolis, Laboratoire de Chimie Moléculaire, Unité
Associée au CNRS 426, Parc Valrose, 06108 Nice Cedex 2, France.

ABSTRACT: New anionic amphiphiles with a phosphate ester junction between the fluorophilic-lipophilic tail and the sugar-based hydrophilic head were synthesized and evaluated. The single hydrophobic chain surfactants **1a,b** and **2a** allowed the preparation of stable and fine highly concentrated emulsions of perfluorodecalin or perfluorooctyl bromide, either when used alone or in conjunction with egg yolk phospholipids (EYP). Surfactants **3d**, **5d**, **6d** and **6e**, with two hydrophobic chains, one fluorinated the other not, gave liposomal structures, and displayed encapsulation properties for carboxyfluorescein. The phosphodiester tested cause no significant inhibition of the growth and viability of Namalva cell cultures (0.1-1 g/L range). Single chain phosphodiester manifest no detectable hemolytic activity (at 100 g/L for **1a**) whereas double chain compounds do moderately (*ca* 20% hemolysis at 20 g/L). The maximum tolerated dose compatible with the survival of all of a series of 10 intravenously injected mice is in 130 mg/kg body weight range.

INTRODUCTION

In vivo administration of oxygen using fluorocarbon emulsions has become a major objective, and intensive research is devoted to optimizing the emulsions' characteristics for specific applications [1]. Likewise delivery of drugs by means of vesicles, which overcomes such problems as premature drug breakdown, drug release level, targetting, longevity, necessitates improved control over the characteristics and properties of membranes [2]. In both cases, improved control of

the fluorocarbon droplet or vesicle's particle size, size distribution, charge, stability, *in vivo* recognition, intravascular persistence, biodistribution etc, are desirable. Consequently, the design and development of well-defined biocompatible amphiphiles with modular molecular structures, to be used as membrane constituents, stabilizers and surface modifiers, are primordial.

In view of the results obtained so far 1) on emulsion stabilization with neutral or amphoteric perfluoro- (or *F*-) alkylated surfactants [3], or with mixed fluorocarbon-hydrocarbon amphiphiles (the so-called molecular dowels) [4], and 2) on the exceptionally high stability of liposomes formed by *F*-alkylated glycerophosphocholines [5], we decided to synthesize and evaluate new anionic amphiphiles with a phosphate ester junction between the fluorophilic-lipophilic tail and the sugar-based hydrophilic head (fig. 1). Such amphiphiles also allow the introduction of a relatively hidden negative charge in the interfacial surfactant film which makes bilayer rigid surfaces [6].

Among these amphiphiles, compounds **1-2**, which have a single *F*-alkylated hydrophobic tail, were evaluated for stabilizing emulsions, while the others, **3-6**, which have an unsymmetrical mixed double-chain tail (one being fluorinated), were evaluated for their ability to form supramolecular structures. Hydrocarbon counterparts, **1c** and **6f**, were synthesized to evaluate the impact of the *F*-alkyl chain on the physicochemical and biological behavior of these surfactants.

MATERIALS AND METHODS

Synthesis: The phosphodiester **1a-c** and **2a** were prepared in *ca* 60% yield (based on consumed sugar) in three steps from POCl₃ [7a]. In spite of the need of a two-fold excess of the *F*-alkylated alcohol, this procedure was efficient and convenient since no column chromatography purification was needed. Compounds **3-6** were synthesized through a three-step *H*-phosphonate route [7b]. This method does not require an excess of sugar, is easy to handle, and gives good yields (50-70%); moreover, all the intermediates formed are stable in air at room temperature.

Biocompatibility: The products were tested according to [8].

Preparation of emulsions (50% w/v) by sonication: The preparation of 12 mL of *F*-decalin (FDC, Air products, USA)/surfactant [50/3% (w/v)] emulsions was achieved by first sonicating the surfactant (360 mg) in water for injection (8.55 mL) in an ice-cooled rosette cell, until total dispersion, then adding FDC (6 g) and sonicating until no significant improvement in average particle size or particle size distribution was observed.

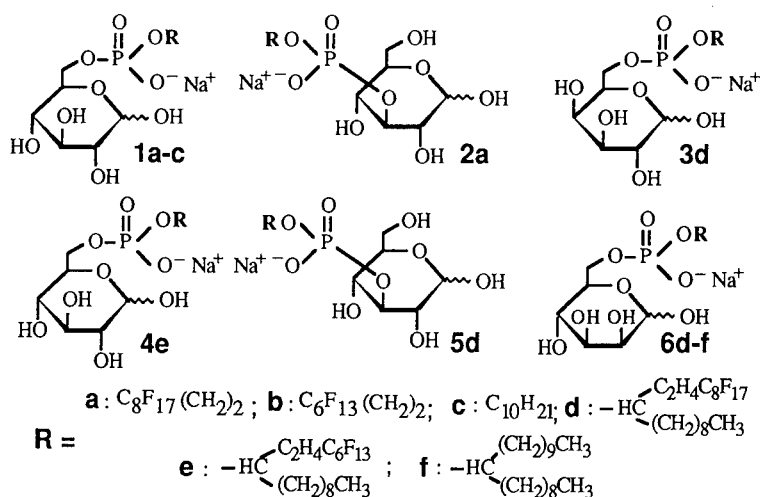

FIGURE 1: Anionic Perfluoroalkylated Sugar Phosphates.

Preparation of highly concentrated emulsions (90% w/v) by microfluidization: The appropriate surfactant system [**1a** (1% w/v) or **1a**/EYP (total amount 4% w/v)] was first dispersed under argon at 15°C in 19.6 mL of a phosphate buffer with an Ultra-Turrax mixer for 1 min. at 8000 rpm. *F*-Octyl bromide (perflubron, Hoeschst, Germany, 36 g) was added. After 10 min. of stirring at 24000 rpm, the resulting premix was run through the microfluidizer (Microfluidics Corp., USA).

Storage and characterisation of the emulsions: The emulsions were stored at 40°C in order to accelerate the aging process; average particle sizes and particle size distributions were measured by photosedimentation (Horiba Capa 700).

Preparation and characterisation of vesicles: Vesicles with homogeneous populations were obtained by sonicating aqueous solutions (50 mM) of compounds **3-6** for 2 min. at 50°C; their diameters were analyzed by Laser Light Scattering Spectroscopy (LLSS) at 20°C (Coulter N4MD).

Electron microscopy (Philips CM 12, 80 kV) [9]: Samples were prepared by placing a drop of a sonicated dispersion on Formvar grids, followed by staining with a phosphotungstic acid solution (2%, pH adjusted at 7).

Encapsulation and release studies: **3d**, **5d**, and **6d,e** were dispersed in an aqueous solution of carboxyfluorescein (CF) (100 mM). Column chromatography on

Sephadex G-50 was used to remove non-entrapped CF. After dilution (Hepes.Na₂SO₄ buffer solution), fluorescence monitoring of CF leakage through membranes was recorded over time at 37°C.

RESULTS AND DISCUSSION

Biocompatibility

The *F*-alkylated phosphodiester **1a,b** and **2a** had no hemolytic effect (at 100 g/L for **1a**) on human red blood cells suspended in an isotonic 0.9% NaCl solution. Phosphodiesters with double mixed tails demonstrated some hemolysis at high concentration (*ca* 20% hemolysis at 20 g/L). The hydrocarbon counterparts **1c** and **6f** were already highly hemolytic at 0.1 g/L. Solutions of single and double perfluoroalkylated chain phosphodiesters (0.1-1 g/L) caused no significant inhibition of the growth and viability of lymphoblastoid cells of the Namalva strain. Compound **1b** had an intravenous LD₅₀ of about 750 mg/kg bw in mice whereas products **3-6** were tolerated (all 10 animals survived) at 130 mg/kg bw doses.

Fluorocarbon emulsion stabilization

A comparative evaluation of water-soluble anionic surfactants **1a,b** and **2a** in 50% (w/v) FDC emulsions indicated significantly better emulsifying properties than those of natural EYP. The fluorinated surfactants, either alone or in conjunction with EYP, gave smaller particles, both at the time of preparation and after 1 month at 40°C than those obtained with EYP alone. The *F*-octyl derivatives **1a** and **2a**, independently of the location of the phosphate group on the glucose moiety, were more effective than the *F*-hexyl one **1b**. The remarkable emulsifying properties of these compounds appear related to the presence of the anionic P(O)O connector. They are also greatly enhanced by the *F*-alkyl chain compared to the hydrogenated analogue **1c**. These effects are even more pronounced with the more concentrated (90% w/v) perflubron emulsions. Replacement of a small amount (1/8th) of the EYP by **1a** in perflubron/EYP emulsions facilitated the emulsification, reduced the average particle size significantly, and achieved strong stabilization of the emulsions [10]. Increasing the fluorinated surfactant/EYP ratio resulted in no significant additional benefit. The perflubron emulsions (90% w/v), obtained with only 1% of **1a** as the sole surfactant, were markedly more stable than those containing 4% EYP; the average particle size was 0.4 μm (40°C, 3 months).

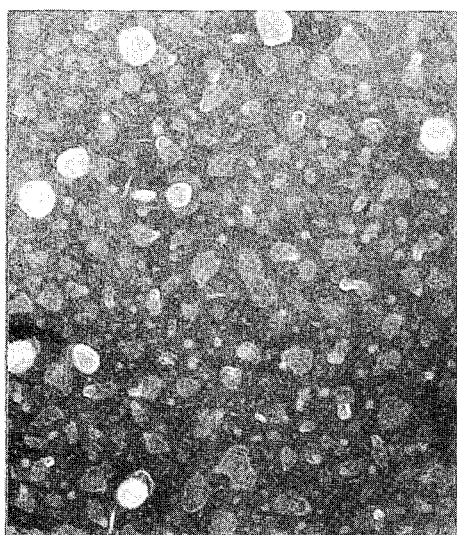

FIGURE 2: Electron micrograph of aqueous dispersion (sonication) of **3d**

Liposomes and encapsulation

The ability of the mixed double chain anionic phosphodiester to form vesicles in water was investigated. Compounds **3d**, **5d**, **6d-f** gave clear to translucent aqueous dispersions by sonication. Their observation by electron microscopy revealed the presence of homogeneous supramolecular structures constituted by single unilamellar vesicles (SUV) with a mean diameter of 25 to 45 nm (confirmed by LLSS). The micrographs (fig. 2) display patterns close to those observed for liposomes made of natural phospholipids or vesicles of synthetic organic amphiphiles.

Vesicles prepared from compounds **3d**, **6d,e** were stable at 4°, 25° and 40°C for 3 months. Vesicles formed from **6f** and **5d** precipitated after 12 hours and 15 days, respectively, and **4e**, whatever the aqueous concentration, precipitated immediately after sonication. This further illustrates the higher vesicle-forming and stabilizing ability of fluorocarbon amphiphiles, even with short hydrophobic chains.

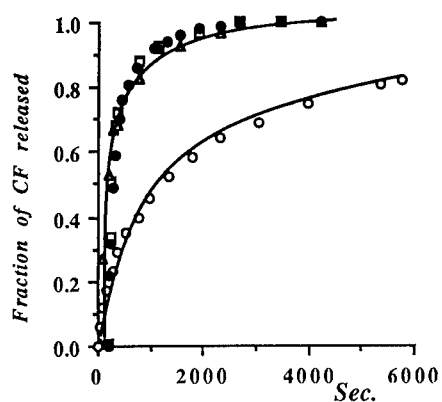

FIGURE 3: Release of CF vs time for vesicles formed from **3d** (○) **5d** (□), **6d** (●), **6e** (▲).

The phase transition from the frozen gel-like state to the fluid liquid-crystalline state was not seen by DSC or by ^{31}P -n.m.r. (line width vs temperature). This may be due to a non-cooperative large transition related to the large difference of hydrophobicity of the two tails.

The presence of closed vesicles was further established by using Wernstein's process [11] which takes advantage of the self-quenching of the fluorescence of CF when the dye is entrapped in vesicles. Release of CF from the vesicle results in dilution of the dye and rapid build-up of fluorescence. In all the cases investigated, initial quenching of fluorescence evidenced encapsulation of the dye. It was found that CF was then rapidly released from vesicles prepared from **5d**, **6d**, **e** (50% release after ~3 min). By contrast **3d** exhibited greater impermeability, with 50% of release after 25 min. (fig. 3). In the same conditions, dimyristoylphosphatidylcholine had $T_{1/2}$ similar to **3d**. These experiments indicate that the enhanced barrier against permeation of CF is highly dependent on the nature of the sugar ($T_{1/2}$ galactose \gg glucose \sim mannose), whereas the lengthening of the fluorocarbon segment from **6e** to **6d** does not seem to increase membrane impermeability significantly. In view of their behavior distinctly different from that of the hydrocarbon analogue, surfactants with a fluorinated hydrophobic tail may play a valuable role as membrane modifiers.

Acknowledgement: We thank the CNRS and ATTA for their generous support and ATOCHEM for the gift of fluorocompounds.

REFERENCES

- 1 J.G. Riess, in *Blood Compatible Materials and Devices*, Technomics Publ. Co., Lancaster, (Pa, USA) 1991, chap. **14**, 237-270; J.G. Riess, *Vox Sang.*, **61**, 225-239 (1991).
- 2 T. Kunitake, *Angew. Chem. Int. Ed. Engl.*, **31**, 709-726 (1992).
- 3 see for example: L. Zarif, A. Manfredi, C. Varescon, M. Le Blanc, J.G. Riess, *J. Am. Oil Chem. Soc.*, **66**, 1515-1523 (1989); J. Greiner, J.G. Riess, S. Abouhilale, A. Milius, *Prog. Colloid Polym. Sci.*, **88**, 123-130 (1992); A. Milius, J. Greiner, J.G. Riess, *New J. Chem*, **16**, 771-773 (1991).
- 4 J.G. Riess, M. Postel, *Biomat. J. Disp. Sci. Technol.*, **20**, 819-830 (1992).
- 5 C. Santaella, P. Vierling, J.G. Riess, *Angew. Chem. Int. Ed. Engl.*, **30**, 567-568 (1991).
- 6 A. Wagenaar, L.A.M. Rupert, J.B.F.N. Engberts, *J. Org. Chem.*, **54**, 2638-2642 (1989).
- 7 a) A. Milius, J. Greiner, J.G. Riess, *Carbohydr. Res.*, **229**, 323-336 (1992);
b) F. Guillod, J. Greiner, J.G. Riess, unpublished results.
- 8 L. Zarif, J. Greiner, S. Pace, J.G. Riess, *J. Med. Chem.*, **33**, 1262-1269 (1990).
- 9 *Liposomes, a practical approach*, RRC New ed., IRC Press, Oxford, (1990).
- 10 A. Milius, J. Greiner, J.G. Riess, *Colloids Surfaces*, **63**, 281-289 (1992).
- 11 J.N. Weinstein, S. Yoshikami, P. Henkart, R. Blumenthal, W.A. Hagins, *Science*, **195**, 489 (1977).

**THE ELIMINATION PECULIARITIES OF PERFLUOROCARBON EMULSIONS
STABILIZED WITH EGG YOLK PHOSPHOLIPID**

T.K. Putyatina, U.D. Aprosin, N.I. Afonin, M.D.
Department of Medical Biotechnology
Research Institute of Experimental and Clinical Immunology
Moscow, Russia

ABSTRACT

In order to examine the elimination rate of Perfluorodecalin (FDC) emulsions stabilized with different emulsifiers - yolk phospholipid (EYP) and procsanol P-268 (analog of Pluronic F-68) - we performed controlled trials on excretion of FDC in exhaled air, elimination from blood and accumulation in the liver. Adult Wistar rats were injected intravenously with FDC emulsions stabilized with different emulsifiers at a dose of 11.5 g FDC per kg body weight. The concentration of FDC in blood, exhaled air and liver tissue was examined by means of the gas chromatography method. The circulation time in blood for the emulsion stabilized with EYP was much longer comparatively to the emulsion containing the synthetic emulsifier procsanol P-268. The injection of EYP dispersions prolonged the circulation time of lipid-stabilised FDC emulsions. The rate of PFC elimination in exhaled air from such an emulsion and the rate of its accumulation in liver during the initial period after injection are reduced compared to the procsanol-stabilized emulsion. These data are interpreted as the result of a reduction of phagocytic activity of blood monocytes toward the lipid-coated particles of the emulsion. The circulation time of PFC emulsion can be prolonged by using lipid emulsifier and additional injections of EYP dispersion.

INTRODUCTION

The circulation time of a blood substitute is one of the main of the mane indicators of its effectiveness. The circulation time of a Perfluorochemical (PFC) blood substitutes depends on the rate of its elimination in exhaled air and deposition in organs mainly in liver and spleen [1, 2]. Though the main pharmacokinetic tendency had already been known the specific peculiarities of the emulsifier influence on the PFC elimination rate has not been studied enough.

This paper intends to estimate the excretion peculiarities of the FDC emulsions stabilized with EYP and procsanol P-268 from

TABLE I: Half-persistence time in blood stream of FDC emulsion with different emulsifier content

Emulsifier content	T 1/2, (hours)
Procsanol P-268	13,5 ± 0,5
Procsanol P-268/EYP 8:2	20,0 ± 1,0
Procsanol P-268/EYP 2:8	22,4 ± 1,1
EYP	24,4 ± 0,9

Values are mean ± s.e.m.

the organs of rats. The influence of additional injections of the EYP dispersion on the circulation time of FDC emulsion stabilized with a different emulsifier was also studied.

MATERIALS AND METHODS

FDC was emulsified by sonication. EYP, procsanol P-268 and the mixtures of these emulsifiers were used.

Adult Wistar strain rats were injected i.v. with FDC emulsions (25%, w/v) at a dose of 11.5 g FDC per kg body weight. EYP dispersion was injected i.p.

The content of FDC in blood, liver tissue and exhaled air were examined by means of gas chromatography using Sigma 115 Gas Chromatographic System (Perkin-Elmer, Sweden). The determination of FDC content in tissue was fulfilled according to the described method (3).

RESULTS

The results obtained showed that the employment of EYP as an emulsifier can prolong FDC emulsion half-persistence time (T 1/2) in the blood stream of rats from 13.5 hr to 24.4 hr (see Table I).

The elimination rate of PFC in the exhaled air of EYP stabilized FDC emulsion was lower than the elimination rate of the emulsion stabilized with procsanol P-268 during the initial 24 hr (Table II).

The rate of accumulation in the liver of EYP stabilized FDC emulsion was also lower than the accumulation rate of the emulsion stabilized with procsanol P-268 during the same period of time (Table III).

The additional injections of 20% EYP dispersion increased the T 1/2 of EYP stabilised FDC emulsion more than two times (from 24,5 hrs up to 54 hrs). But the circulation time of the FDC emulsion which contained procsanol P-268 could not be increased by additional injections of EYP dispersion (Table IV).

TABLE II: The elimination rate with exhaled air of FDC emulsions stabilized with different emulsifiers (ml FDC/kg/h x 1000)

Time after injection	Emulsifier	
	Procsanol P-268	EYP
1 hr	6,45 ± 0,52 *	3,61 ± 0,61 *
5 hrs	6,79 ± 0,56 *	4,20 ± 0,31 *
9 hrs	5,17 ± 1,20	4,32 ± 0,79
24 hrs	4,56 ± 0,92	4,10 ± 0,68
33 hrs	4,58 ± 0,77	3,76 ± 0,89
2 days	3,96 ± 0,56	2,60 ± 0,92
3 days	3,50 ± 0,60	2,75 ± 0,51
4 days	3,10 ± 0,32	2,80 ± 0,58
7 days	2,90 ± 0,61	2,80 ± 0,21
14 days	2,65 ± 0,32	2,50 ± 0,35

Values are mean ± s.e.m.; *P<0,05

TABLE III: The FDC content in the liver of the rats injected FDC emulsions stabilized with different emulsifiers (ml FDC/g tissue x 100)

Time after injection	Emulsifier	
	Procsanol P-268	EYP
9 hrs	0,080 ± 0,009 *	0,042 ± 0,006 *
22 hrs	0,140 ± 0,009 *	0,095 ± 0,007 *
2 days	0,150 ± 0,009	0,150 ± 0,008
3 days	0,130 ± 0,007	0,120 ± 0,007
4 days	0,096 ± 0,005	0,075 ± 0,007
7 days	0,080 ± 0,005	0,086 ± 0,006
2 weeks	0,027 ± 0,002	0,043 ± 0,003
3 weeks	0,015 ± 0,001	0,016 ± 0,001

Values are mean ± s.e.m.; *P<0,05.

TABLE IV: Effect of the additional injections of EYP dispersion on half-persistence time in blood stream of FDC emulsion with different emulsifier content

Emulsifier content	T 1/2, (hours)	
	with additional injections	without additional injections
Procsanol P-268	13,4 ± 0,5	16,1 ± 0,9
Procsanol P-268 & EYP	21,6 ± 1,1	24,8 ± 0,9
EYP	24,4 ± 0,9	54,4 ± 0,6

Values are mean ± s.e.m.

DISCUSSION

It is already known that the process of elimination of FDC emulsions from the organism in exhaled air can be divided into two conventional stages. During the first stage the elimination of the emulsion directly from the blood stream takes place (with the participation of phagocytes); during the second stage the elimination of FDC accumulated in organs takes place. During the first stage the elimination rate is very high, and a large amount of FDC can be exhaled during this period (up to 30% of the injected dose). The elimination rate during the second stage is much lower (2, 4). That is why it had been expected that the prolongation of the circulation time of FDC emulsion can increase the amount of FDC eliminated in exhaled air and can decrease the undesirable accumulations in the liver and spleen.

The comparative study of the elimination rate with exhaled air and the rate of accumulation in liver of FDC emulsion stabilized with procsanol P-268 and EYP showed that the elimination rate and the rate of accumulation in liver of EYP stabilized emulsion during the initial period after injection are reduced compared to the procsanol stabilised emulsion. The cause of such a difference in the rates of elimination in exhaled air and of accumulation in liver between the emulsions stabilized with different emulsifiers can be estimated according to the mechanism of elimination during the first stage. The decrease of the elimination rate in exhaled air and the rate of accumulation in the liver of EYP stabilized emulsion and the simultaneous increase in its circulation time in the blood flow can be explained as a result of the decrease of phagocytic activity towards the FDC particles covered with EYP. So we can conclude that the use of EYP emulsifier leads to prolongation of the circulation time in blood

of PFC emulsion but does not influence the level of its accumulation in organs.

The circulation half-life of EYP stabilized FDC emulsion in blood can be prolonged by additional injections of 20% EYP dispersion. It should be noted that during the initial 22 hrs after injection the FDC concentration remained at the same level. After this period the FDC concentration began to fall, although the rats were still injected with the EYP dispersion. We suppose that the prolongation of the circulation half-life of FDC emulsion by additional EYP injections is connected with the reduction of phagocytic activity towards the FDC particles in the presence of the greater amount of EYP in blood. However the presence of procsanol P-268 in FDC emulsion does not make it possible to prolong the circulation period of FDC emulsion using the additional EYP injections. It is known that Pluronic F-68 and procsanol P-268 have the ability to activate complement (4). Consequently we propose that in this case the phagocytic activation takes place in the presence of procsanol in blood. That is why it is impossible to prolong the circulation period of FDC emulsion which contains procsanol P-268 by means of additional EYP injections.

We can conclude that FDC emulsion stabilized with EYP can circulate in the blood for a long time and the circulation half-life of such an emulsion can be prolonged by additional injections of EYP dispersion, unlike the emulsion which contains procsanol P-268. The emulsifier composition does not influence the level of FDC accumulated in organs.

REFERENCES

1. F. Pfannkuch, N. Schnoy. Long-Term Observation of PFC Storage in Organs of Rats After Various Dosages. *Prog. Clin. Biol. Res.*, 122, p. 209-220, (1982).
2. Y. Tsuda, K. Yamanouchi, K. Yokoyama, T. Suyama. Discussion and Consideration for the Excretion Mechanism of Perfluorocarbon Emulsions. *Blood Substitutes* (ed. Chang T.M.S.), Marcel Dekker, INC. N.Y., p. 473-483, (1989).
3. U.D. Aprosin, V.K. Alekseeva, N.I. Afonin. The Determination of Fluorocarbons in Organs by means of Gas Chromatography. *Problems of Haematol. & Blood Transfusion*, N. 1, p. 58-60, (1982).
4. D.P. Sidlyarov, U.D. Aprosin, N.I. Afonin. The Elimination Peculiarities of Perfluorocarbons of Different Classes with Exhaled Air after Injection of their Emulsions. *Haematol. & Transfusiol.*, N. 7, p. 51-58, (1983).

**OXIDATIVE ASSESSMENT OF PHOSPHOLIPID-STABILIZED
PERFLUOROCARBON-BASED BLOOD SUBSTITUTES.**

* T.E. Tarara, S.H. Malinoff, and T.J. Pelura
Alliance Pharmaceutical Corp., 3040 Science Park Road,
San Diego, CA USA 92121

ABSTRACT

Methods based on the HPLC separation with subsequent UV detection and spectrofluorimetry have been developed to monitor the formation of oxidative decomposition products of phospholipids in perfluorocarbon emulsions. Catalytic, as well as emulsion oxidative stability studies have been conducted utilizing egg yolk phospholipid (EYP) and perfluorocarbons of varied compositions/purity in order to assess their effect on susceptibility to oxidation. Our studies indicate that phospholipid composition, degree of unsaturation, perfluorocarbon purity and the presence of oxygen and trace metals have a significant effect on the formation of oxidative decomposition products. A combination of methods has proven useful in monitoring the levels of oxidative decomposition products of phospholipids in phospholipid-stabilized perfluorocarbon-based blood substitutes. Such an approach has proven beneficial in the development of pharmaceutical agents of potentially higher quality and storage stability.

INTRODUCTION

Preparations based on phospholipid-stabilized perfluorocarbon emulsions have been examined extensively in the pharmaceutical arena as potential blood substitutes [1-5]. However, little information exists on the autoxidation of phospholipids and phospholipid-stabilized perfluorocarbon emulsions and current analytical methods fall short in assessing the oxidative history of such lipids. The component phosphorus amine and unsaturated fatty acid moieties of phospho-

lipids offer a more complex system to study than neutral lipids species. In addition, impurities in fluorocarbons, unsaturated species, may act to facilitate the autoxidation of phospholipids and likewise phospholipid oxidative products may react with susceptible fluorocarbon species. Oxidation of lipids in biological systems have been shown to have toxicological significance which includes changes in membrane integrity and/or the formation of potentially detrimental decomposition products [6]. This study attempts to characterize the effects that phospholipid concentration, oxygen, trace metals content, storage temperature and time and composition/purity of both phospholipids and perfluorocarbons have on the oxidative stability of phospholipids in perfluorocarbon emulsions.

METHODS

Emulsions containing perflubron (perfluorooctyl bromide; PFOB) or perfluorodecalin (FDC), stabilized with EYP, were made by high pressure homogenization. Natural, synthetic and partially hydrogenated egg yolk phospholipids were obtained commercially. The emulsions were phosphate buffered to physiologic pH and contained an antioxidant and metal chelator to protect the oxidatively labile phospholipid surfactant. The emulsions were terminally sterilized in a rotating autoclave at 121°C.

Formation of oxidative decomposition products in phospholipids and phospholipid-stabilized perfluorocarbon emulsions were monitored during processing and subsequent storage by determination of their aldehyde content and relative fluorescence intensities. Dinitrophenylhydrazones of the aldehydes were quantified using reverse-phase HPLC with UV detection on a Beckman System Gold Chromatograph [7]. Direct measurement of fluorescent substances were performed on a RF-5000 Shimadzu Spectrofluorophotometer in order to monitor the generation of oxidative "end" products [8]. Phospholipid class analyses were performed by HPLC separation and subsequent quantitation with a Cunow DDL 21 Light-Scattering Detector [9].

RESULTS AND DISCUSSION

The concentration of hexanal, relative amount phospholipid-aldehydes and relative fluorescence intensities were found to correlate well with each other, phospholipid concentration, oxygen and trace metals content, storage temperature and time and composition/purity of both phospholipids and perfluorocarbons.

The formation of oxidative decomposition products as a function of phospholipid concentration is shown in Figure 1. As the concentration of EYP was increased, the relative amount of hexanal increased. On the other hand, the amount of fluorescent substances present was found to be proportional to the EYP concentration. The reason for this difference could be due to the increased population of "free" vesicles that occur at higher EYP concentrations which may be more conducive to form more secondary oxidative products than "end" products.

Phospholipid-stabilized perfluorocarbon emulsions were spiked and subsequently incubated with cupric sulfate and/or oxygen to assess their oxidative susceptibility. Formation of oxidative products were found to increase upon sterilization, while little differences were seen between the control and the samples spiked with Cu^{2+} and O_2 alone (Figure 2). When the same formulation was spiked with both Cu^{2+} and O_2 , a dramatic increase in hexanal and fluorescent substances resulted. Clearly contamination of Cu^{2+} and O_2 alone will not result in increased oxidation; however, when in combination they induce oxidative stress beyond the effectiveness of the added antioxidant and metal chelator.

Perfluorocarbon emulsions containing various commercial EYP's were prepared and assessed for the generation of oxidative products. The phospholipids used in this study differ mainly in the levels of phosphatidylethanolamine (PE) and phosphatidylcholine (PC) and iodine value (Table I). Iodine value is a measure of the total unsaturation of the component fatty acids. Natural EYP, as extracted from hen's eggs, has an iodine value of 65 to 75. The results in Table I indicate that the presence of hexanal is related to the level of unsaturation and the generation of fluorescent-substances is related to the concentration of PE. Autoxidation of unsaturated fatty acids lead to the formation of reactive aldehydes, such as hexanal, which easily condense with primary amines, such as PE, yielding fluorescent Schiff bases.

A phospholipid-stabilized perfluorocarbon emulsion, prepared as described above, was incubated at 5°C and 40°C to assess its oxidative stability. The formation of fluorescent substances was found to be dependent on the incubation temperature, with increasing temperature, the amount produced increased (Figure 3). However the formation of hexanal was found to decrease at 40°C and increase slightly at 5°C as a function of time. The disappearance of hexanal with time at higher temperatures is most likely due to its condensation with primary amines, i.e. PE, which yield fluorescent end products.

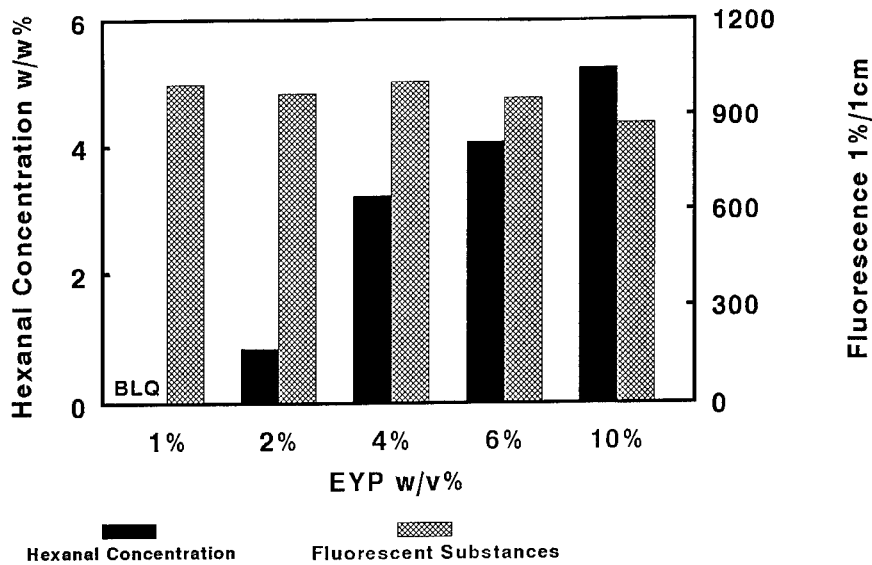

FIGURE 1. The formation of oxidative decomposition products as a function of phospholipid concentration. Fluorescent-substances generated were found to be proportional to the EYP concentration; whereas the hexanal concentration was not.

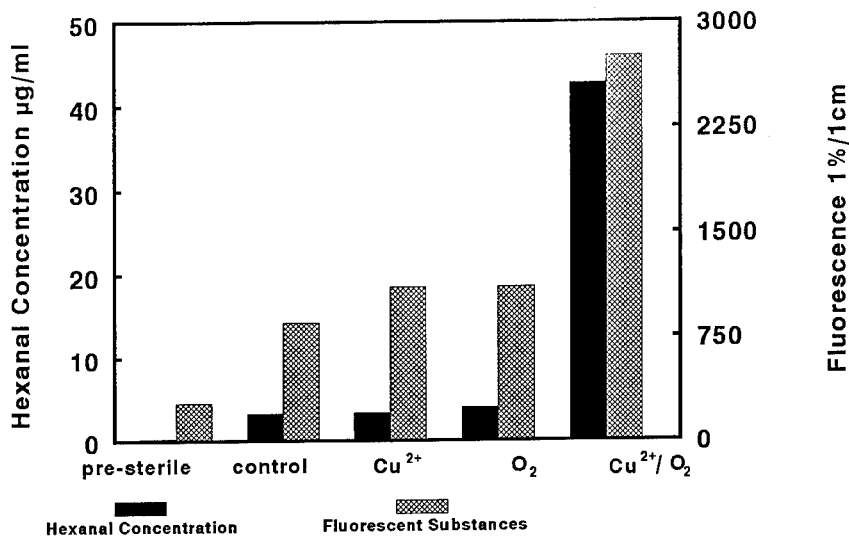

FIGURE 2. Catalytic and oxidative susceptibility of fluorocarbon emulsions. Contamination of Cu²⁺ and O₂ in combination induced oxidative stress beyond the effectiveness of the antioxidant and metal chelator.

TABLE I. Effect of phospholipid composition on oxidative decomposition of phospholipids in concentrated perflubron emulsions (90% w/v perflubron, 4% w/v total surfactant).

Vendor	I.V.	PUFA %	PE %	PC %	Hexanal (µg/mL)	Fluorescence 1%/1cm
Vendor A	75	12.59	14.59	69.60	5.65	1111
Vendor B	75	14.56	19.39	69.06	0.76	793
Vendor C	75	12.20	14.50	71.88	3.76	1915
E80-65	65	11.74	6.71	84.44	BLQ	1584
E80-35	35	1 to 2	5.86	84.51	BLQ	300
E100-65	65	5.5 to 6.5	0.00	95.60	BLQ	219
E100-35	35	0.5 to 1	0.00	93.99	BLQ	129

I.V. = Iodine Value
 PUFA = Polyunsaturated Fatty Acid
 BLQ = Below Limit of Quantitation
 PE = Phosphatidylethanolamine
 PC = Phosphatidylcholine

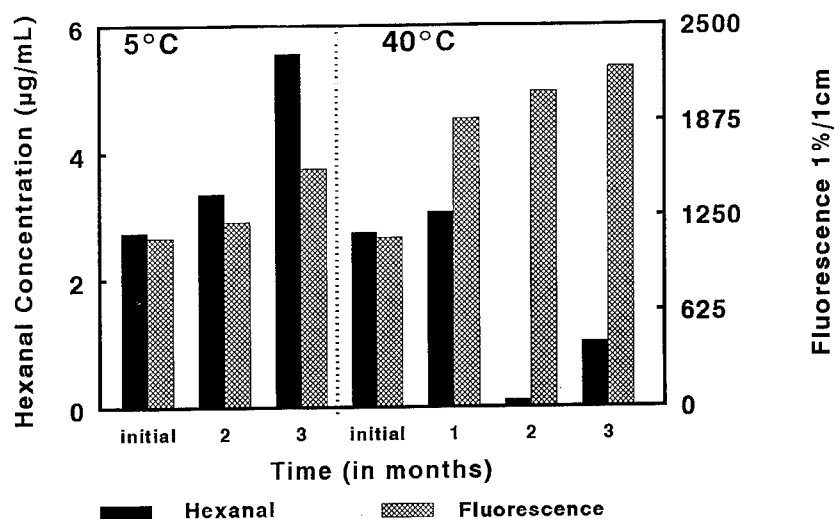

FIGURE 3. The effect of storage temperature and time on the generation of oxidative decomposition products. With time and temperature, hexanal was lost to fluorescent end products via condensation with phosphatidylethanolamine.

To determine the influence of fluorocarbon impurities on the oxidative decomposition of phospholipid, emulsions of impure (FDC as supplied) and purified FDC were manufactured. Hexanal concentration, fluorescence intensity and free fluoride concentration were found to differ greatly between emulsions made of impure and purified FDC, where the percent reduction of hexanal, fluorescence and fluoride was found to be 31%, 54%, and 787%, respectively. This data indicates that certain fluorocarbon impurities, possibly unsaturated species, may be involved in the initiation, propagation and termination steps of phospholipids oxidation.

CONCLUSIONS

- Phospholipid composition, concentration, unsaturation (iodine value) of constituent acyl groups, storage temperature, sterilization and perfluorocarbon purity contribute to the oxidative susceptibility of phospholipid-stabilized perfluorocarbon-based blood substitutes.

- The concentration of hexanal, and relative fluorescent intensities were found to correlate well with the oxidative history of phospholipids and phospholipid-stabilized perfluorocarbon-based blood substitutes.
- Studies to further characterize the phospholipid-aldehydes and phospholipid/fluorocarbon reactions are underway.

REFERENCES

- [1] J.G. Riess, *Vox. Sang.* **61**, 225 (1991).
- [2] J.G. Riess, In: "*Blood Substitutes and Oxygen Carriers*", T.M.S. Chang, Ed.; M. Dekker, New York, 1993, p. 24-43.
- [3] N.S. Faithfull, In: "*Blood Substitutes and Oxygen Carriers*", T.M.S. Chang, Ed.; M. Dekker, New York, 1993, p. 569-576.
- [4] T.J. Pelura, C.J. Johnson, T.E. Tarara, and J.G. Weers, *Biomat., Art. Cells & Immob. Biotech.* **20**, 845 (1992).
- [5] M.-P. Krafft, J.-P. Rolland, and J.G. Riess, *J. Phys. Chem.* **95**, 5673 (1991).
- [6] H. Esterbauer, and K.H. Cheeseman, *Chem. Phys. Lipids* **45**, 103 (1987).
- [7] J.K. Beckman, S.A. Morley, and H.L. Greene, *Lipids* **26**, 155 (1991)..
- [8] C.J. Dillard, and A.L. Tappel, *Lipids* **8**, 183 (1973).
- [9] T.E. Tarara, and T.J. Pelura, manuscript in preparation.

**EFFECT OF PERFLUORO-CHEMICAL EMULSION ON LIPOPROTEINS OF PLASMA
BLOOD**

N.N. Doronina, O.A. Kurmacheva, N.I. Afonin, M.D.
Department of Medical Biotechnology
Research Institute of Experimental and Clinical Immunology
Moscow, Russia

ABSTRACT

The effect of perfluorocarbons (PFC, Perfluorodecalin/Fogalin) on the lipoprotein level in plasma was studied. The PFC emulsion (FCE) was injected i.v. at a dose of 6 g PFC per kg of body weight into male Wistar rats weighing 250-280 g. The lipoproteins were separated by preparative centrifugation. It was found that PFCs influence the metabolism of lipoproteins. The greatest depletion of cholesterol level occurs in the HDL fraction of lipoproteins 3 and 24 hrs after injection. There is no relationship between the level of cholesterol in plasma and cholesterol lipoproteins. The content in lipoproteins, however, amounts to half the level of the cholesterol of plasma 72 hrs after injection. Based on these facts it is possible to conclude that when PFCs leave the cells of organs, they are carried in the blood stream as a complex which contains at least PFCs, cholesterol and triglycerides.

INTRODUCTION

Some contemporary blood substitutes based on emulsions of perfluorocarbons are comprised of yolk phospholipids and Pluronic F-68 [2]. The total surface area of PFC particles in emulsions is very large and in the blood stream they are in contact with blood cell membranes as well as blood proteins and lipids. As reported in early investigations, the composition of the lipid surfactant on the particle of PFC emulsions was changed after intravenous infusion [3]. The particles were enriched by cholesterol (CL). It has also been shown that the absorption of CL from membrane of erythrocytes takes place [1]. Evidently in the blood stream the particles of PFC emulsion are interacted with lipoproteins (LP).

Now we report on experiments to identify the effects of PFC emulsion upon blood serum LP in rats.

MATERIALS AND METHODS

Female Wistar rats (body weight: 150-180 g) were used. The emulsion consisted of 20% (v/v) perfluorochemicals: 7 parts

perfluorodecalin, 3 parts Fogalin, Procsanol P-268 (2,8% w/v), and yolk phospholipids (0,35% w/v) as emulsifiers. Twelve rats were divided into a control (saline) group and FCE group, and injected i.v. with FCE, 2,5 ml/kg, and saline, 2,5 ml/kg, respectively. Three, 24, 72 hrs after injection venous blood was collected into tubes containing Na-sal EDTA. LP were separated by preparative ultracentrifugation. CL, triglycerides (TG), phospholipids (PL), in serum and LP fractions were measured by routine methods.

RESULTS

The lipid content in plasma are given in the table I. The TG content showed a marked increase in response to FCE injection during 3 days. It was increased up to a maximum of 143 % after 3 h.

The CL level fell down to about 60% of normal value after 3 h and increased up to 22% and 134% after 24 and 72 hrs, respectively. The PL content also increased after 72 h.

The content of CL and TG in LP fraction are shown in the table II.

The level of CL in the VLDL increased after injection of FCE and significantly increased ($P < 0,01$) at the third day. The CL level in the LDL decreased after 3 hr and it was noted to be elevated after 24 and 72 hrs. The CL level in the HDL decreased after 3 and 24 hrs but at third day the level of CL increased up to 131%.

The TG content was increased in all fractions of LP after 3 h. Elevation of CL in LDL and HDL developed up to 24 h. After 3 days the level of TG in LDL was decreased. The PL content in VLDL increased after 3 h, on the other hand, it was decreased in HDL. The PL level in LDL was increased up to 24 h after infusion FCE.

DISCUSSION

The purpose of this study was to evaluate the influence of FCE infusion on the level of lipids and LP in rat plasma. These results showed that injection of FCE into rats produced alteration in plasma and LP lipids level. The observed increases in plasma TG level was caused by infusion of Procsanol P-268 into blood stream. It is known that surfactants of Pluronic type induces synthesis of TG by the liver. High level of TG in LP fractions occurs during 24 h after FCE injection and is similar with the time of circulation of FCE in blood stream. After 3 days the level of TG in VLDL and HDL was normalized when in plasma the TG content is above the normal value.

The low content of CL in plasma after 3 h indicated that it is absorbed by the particles of FCE. Decrease of CL level in plasma indicates the interaction between HDL and particles of FCE. As a result the CL leaves the HDL. After 3 days the CL level in plasma significantly increased. At the same period the CL level in LP fractions also increased. These data demonstrate that in response to absorption of CL by particles of FCE from HDL the

TABLE I: Lipids content in rat plasma after infusion of perfluorocarbon emulsion, (mg/dl)

Lipids	Time after injection, hrs			
	Control	3	24	72
CL	49,0±2,7	31,3±5,32	59,0±1,7**	115,3±3,9***
TG	72,4±4,2	175,5±8,3***	109,0±10,8*	97,0±5,6*
PL	71,7±5,2	-	-	116,0±6,4**

Values are mean ±s.e.m.*P< 0,05;**P< 0,01;***P< 0,001

TABLE II: Effect of perfluorocarbon emulsion on level of lipids in lipoprotein fraction

Fraction of very low density lipoproteins (VLDL), mg/dl				
Lipids	Time after injection, hrs			
	Control	3	24	72
CL	2,0±0,37	4,83±0,7**	4,67±0,8*	6,0±1,1**
TG	29,0±3,59	90,80±16,0**	32,33±5,57	35,8±5,1

Fraction of low density lipoproteins (LDL), mg/dl				
Lipids	Time after injection, hrs			
	Control	3	24	72
CL	4,8±0,74	3,5±0,07	22,67±2,5***	13,0±0,76***
TG	9,6±0,68	16,5±1,23***	32,33±2,1***	5,0±0,89**

Fraction of high density lipoproteins (HDL), mg/dl				
Lipids	Time after injection, hrs			
	Control	3	24	72
CL	35,0±2,73	14,8±1,78***	15,2±1,46***	46,4±2,3*
TG	4,0±1,23	24,3±4,11***	46,8±5,32***	3,8±0,66

Values are mean ±s.e.m.*P< 0.05; **P< 0.01; ***P<0.001

synthesis of CL increased. In this period disbalance between CL level in plasma and in LP was noted.

We conclude that infusion of FCE stabilized with Procsanol P-268 and yolk phospholipids influence the metabolism of lipoproteins. The decrease of CL level in plasma is a result of its absorption by FCE particles mainly from HDL. It is supposed that PFCs leaving the RES organs exist in blood vessels as a complex with lipoproteins [3]. Our data suggested that PFCs exist in blood stream as a complex which contains at least PFCs, CL and TG.

REFERENCES

1. N.N.Doronina, E.V.Tereshina, O.S.Smelova, N.I.Afonin. The lipid composition absorbing by Perfluorocarbon emulsion in blood stream. The materials of 58th scientific session CSRI of Haematol. and Blood Transfusion, Moscow, p.80-81, (1986).
2. R.P.Geyer. PFC as blood substitutes - an overview. Progress in clinical and biological research, New York, 122, p.157-168, (1982).
3. V.V.Obraztsov, E.T.Prichodkina, S.G.Bezborodnikov, N.N.Brustovetsky. Interaction of proteins and phospholipids with Fluorocarbon emulsion. Fluorocarbons Gastransport Medium, Pushchino, p.147-152, (1984).
4. Y.Tsuda, K.Yamanouchi, K.Yokoama, T.Suyama. Discussion and considerations for the excretion mechanism of Perfluorochemical emulsion. Blood Substitutes, p.473-483 (1989).

EFFECTS OF BUFFER pH AND PHOSPHATE CONCENTRATION
ON THE DROPLET SIZE AND EYP HYDROLYSIS
OF PERFLUBRON/EYP EMULSIONS

D. Song, Ph.D., T. J. Pelura, Ph.D., J. Liu and Y. Ni, Ph.D.
Alliance Pharmaceutical Corp., San Diego, California 92121

ABSTRACT

Oil-in-water emulsions containing perflubron (perfluorooctyl bromide; PFOB) and stabilized with egg yolk phospholipid (EYP) have potential applications as contrast agents and oxygen carriers. In this study, the effects of buffer pH and total phosphate concentration on the emulsion droplet size and EYP hydrolysis were evaluated. 90% w/v perflubron emulsions with NaH_2PO_4 - Na_2HPO_4 buffers of different pH (4.7-8.7) and phosphate concentrations (30 and 60 mM) were prepared with a high-pressure homogenizer. Emulsions were stored at 40°C and tested at 0, 1, 2 and 3 months. The pH dropped quickly in emulsions with pH 8.7 buffer whereas acidic and neutral buffered emulsions exhibited minor pH drops. The concentration of free fatty acids (FFA) vs emulsion pH can be fitted to a parabolic curve with a minimum at about pH 6.0. The droplet growth rates in emulsions with the pH 4.7 buffer were about 2.5 times of those in emulsions with the pH 8.7 buffer. Total phosphate concentration had only a minor effect. This study emphasizes the importance of the careful selection of buffer pH and capacity to control EYP hydrolysis and possibly emulsion droplet size.

INTRODUCTION

Oil-in-water emulsions containing perflubron and stabilized with egg yolk phospholipid have potential applications as contrast agents and oxygen carriers [1-3]. Phosphate, amino acid, or trishydroxymethyl aminomethane (THAM) buffers may be used to maintain pH [4]. In this study, the effects of buffer pH and total phosphate concentration on emulsion droplet size and EYP hydrolysis were evaluated.

MATERIALS AND METHODS

Emulsions containing 90% w/v perflubron, 4% w/v commercial EYP, NaH_2PO_4 - Na_2HPO_4 buffers of different pH (4.7, 5.7, 6.7, 7.7 and 8.7) and total phosphate concentrations (30 and 60 mM) were prepared with a high-pressure homogenizer. The emulsions were terminally sterilized in a rotating autoclave at 121°C. Emulsions were stored at 40°C for accelerated stability tests. pH, droplet size and FFA were measured initially and after 1, 2 and 3 months. Emulsion droplet size was determined by photosedimentation with a Horiba CAPA-700 instrument. FFA generated from EYP hydrolysis were measured spectrophotometrically. ECHIP software (by ECHIP Inc., Delaware) was used for data analysis and for preparing contour plots.

RESULTS AND DISCUSSION

pH in Emulsions

Emulsion pH is expected to decrease on storage, due to the generation of FFA from hydrolysis of the EYP. Phospholipid hydrolysis is acid-base catalyzed and yields FFA and lysophosphatides. Emulsion pH values vs storage time of the emulsions with 30 mM and 60 mM phosphate buffers are shown in Figures 1a and 1b.

The pH dropped only slightly in the emulsions with acidic or neutral buffers. However, dramatic pH drops were noted in the emulsions with the pH 8.7 buffers. The hydrolysis process was catalyzed by OH^- at high pH resulting in free fatty acid generation. The low buffer capacity at pH 8.7 could not maintain the pH. The buffer capacity at pH 8.7 is less than one-third of that at pH 6.7 with the same total phosphate concentration. Emulsion pH decreased rapidly during sterilization due to the temperature acceleration of hydrolysis. The pH of the emulsions with alkaline (pH 8.7 or 7.7) buffers of 60 mM total phosphate was slightly higher (about 0.1 - 0.2 pH units) than that of the counterparts with 30 mM phosphate buffers. The total phosphate concentration (30 or 60 mM) of the acidic or neutral buffers had only a very minor influence on the pH of the emulsions.

EYP Hydrolysis and Free Fatty Acid Concentration

FFA concentration data were fitted by ECHIP. Emulsion pH, storage time and phosphate concentration were used as three independent variables, while FFA concentration was the response. The contour plot of FFA (in milliequivalent/Liter) in the emulsions with 30 mM phosphate buffer vs emulsion pH and storage time is depicted in Figure 2. The effect of the emulsion pH on FFA was nearly quadratic with a minimum at about pH 6 (see below for details) while FFA increased almost linearly with storage time. FFA concentrations in the emulsions

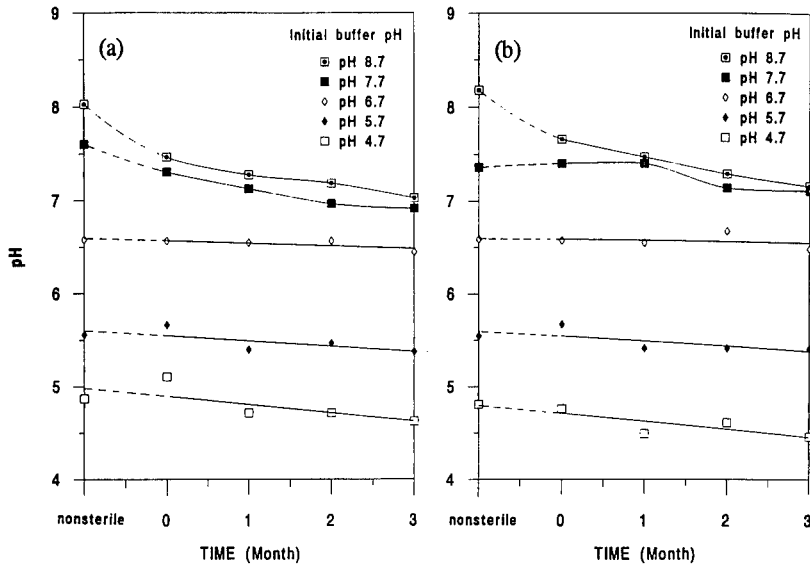

FIGURE 1. pH in emulsions with phosphate buffers of (a) 30 mM and (b) 60 mM.

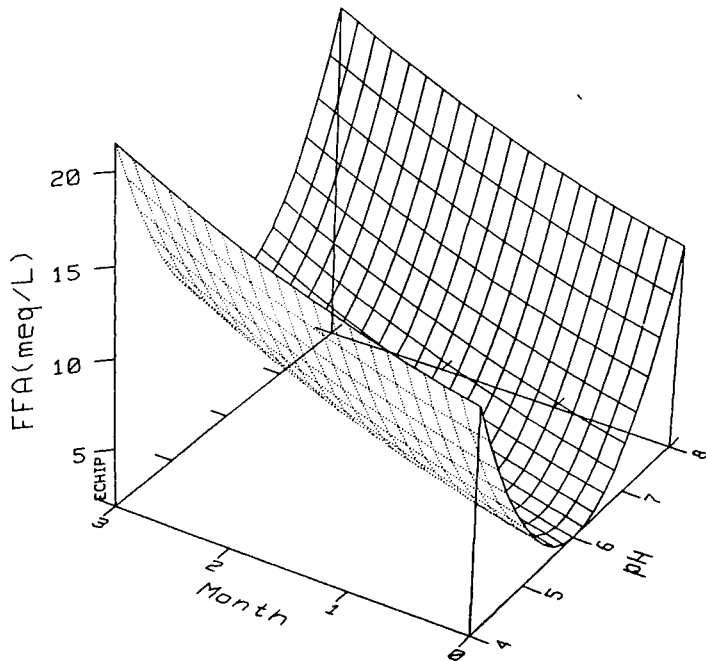

FIGURE 2. FFA in emulsions with 30 mM phosphate buffer vs emulsion pH and time.

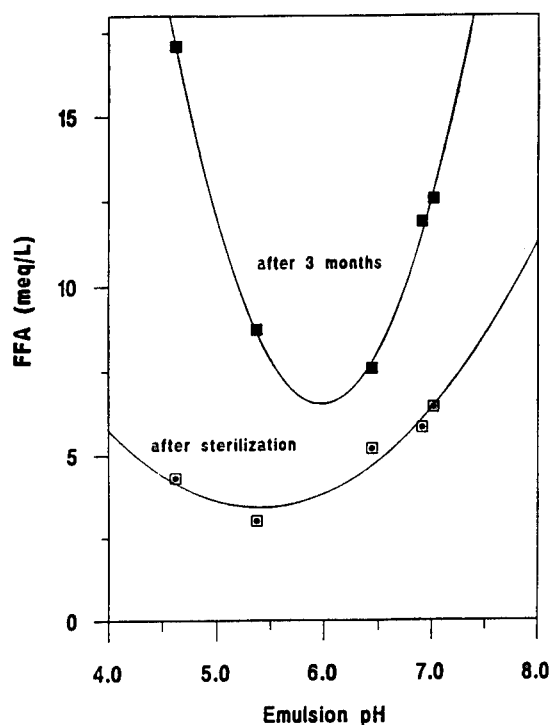

FIGURE 3. FFA in emulsions with 30 mM phosphate buffer at 0 and 3 months vs emulsion pH.

tested after 3 months vs emulsion pH and total phosphate concentration indicated that the phosphate concentration has only a very minor effect on FFA generation.

FFA concentrations in the emulsions containing 30 mM phosphate buffers at 0 and 3 months vs emulsion pH are illustrated in Figure 3. A parabolic relationship is observed where optimum hydrolytic stability (minimal FFA content) is exhibited at pH 6. This is consistent with the following equation: $\text{Rate} = d(\text{FFA})/dt = k_{\text{OH}^-} * [\text{EYP}] * [\text{OH}^-] + k_{\text{H}^+} * [\text{EYP}] * [\text{H}^+]$. The hydrolysis rates were higher in the emulsions with the acidic or alkaline buffers. At 3 months, FFA in the emulsion at pH 6 was about the half of FFA in the emulsion with the pH 7.7 buffer.

The effect of pH on liposome hydrolysis has been studied by S. Frokjaer et al. [5] They investigated distearoyl phosphatidylcholine (DSPC) degradation in a tris buffered aqueous solution at 70°C (ionic strength = 0.5). The initial hydrolytic degradation of DSPC led to the formation of lyso-compounds, which took place at both acidic and alkaline pH. The pH-rate

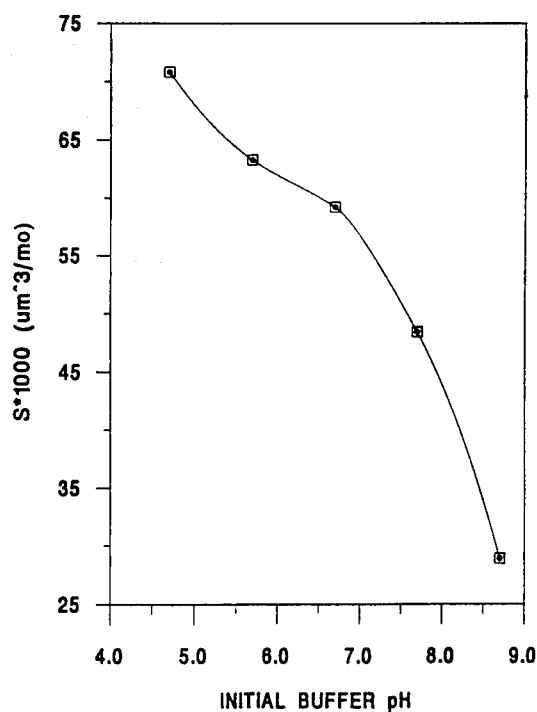

FIGURE 4. Droplet growth rates in emulsions with 30 mM phosphate buffer.

profile for the observed pseudo-first-order rate constant, k_{obs} , was reported [5]. Optimal stability was observed at pH 6.5 implying that the alkali-catalyzed rate constant was larger than the acid-catalyzed rate constant.

We observed the minimum at pH around 6.0, which meant that the ratio of the two rate constants was higher than that reported by Frokjaer. One difference between these two studies is that we investigated perflubron emulsions rather than liposomes. It should also be noted that EYP is a natural mixture of phospholipids containing unsaturated fatty acids while they used a single saturated phosphatidylcholin. Frokjaer chose a high ionic strength (0.5) to maintain pH so that the pseudo-first-order rate constant could easily be calculated. Because of pharmaceutical considerations, the buffer concentrations of 30 mM and 60 mM (equivalent to an ionic strength of less than 0.2) were chosen in our experiments. The emulsion pH could not be held constant in higher pH buffers.

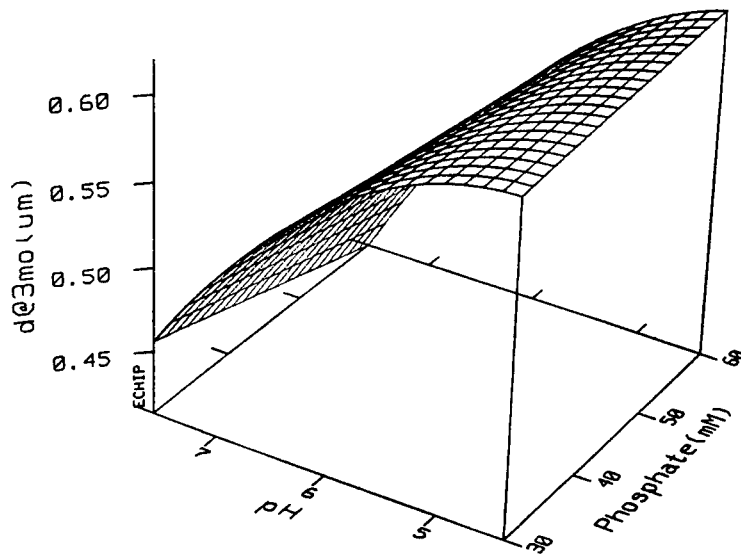

FIGURE 5. Emulsion droplet size at 3 months vs emulsion pH and phosphate concentration.

Emulsion Droplet Growth

Droplet growth rate is one of most important criteria to evaluate emulsion stability. The droplet size growth rate "S" was defined as the slope of linear fit of the cube of the diameter vs time, in $\mu\text{m}^3/\text{month}$. The values of "S" vs initial buffer pH in the emulsions with 30 mM phosphate buffers are plotted in Figure 4. The emulsions with 60 mM phosphate buffers displayed a similar trend in droplet growth. The droplet growth rates in both emulsions with the pH 4.7 buffer were about 2.5 times of those in emulsions with the pH 8.7 buffer.

The contour plot of emulsion droplet size at 3 months vs emulsion pH and phosphate concentration is illustrated in Figure 5. The droplet sizes were nearly the same for the emulsions with different pH buffers at post-sterilization. It was seen that during storage the emulsion droplets grew faster in acidic buffers and that phosphate concentration had only limited influence. The dependence of droplet growth rate on pH may be related to the surface charge of the droplets. Magdassi et al. [6] have reported a correlation between zeta potential and pH at constant ionic strength (0.01). From their curve, it can be estimated that the zeta potentials at pH 7.5, 6, 5, 4 and 3.5 are about -25, -23, -20, -14 and -8 millivolts, respectively. Similarly, when the buffer pH of our emulsions were lowered, the zeta potential at droplet surface should increase

(i.e. from negative to zero). Droplet growth may be retarded at higher negative zeta potentials due to a reduction in interparticle collision mediated by charge repulsion. Davis et al. [7] have shown that Ostwald ripening is the major destabilization mechanism of fluorocarbon emulsions. This study, however, indicates that electrostatic and steric mechanisms may affect diffusional distances between emulsion droplets, hence Ostwald ripening.

REFERENCES

1. J. G. Riess, *Vox Sang*, **61**, 225 (1991).
2. J. G. Riess, in Blood Substitutes and Oxygen Carriers, T. M. S. Chang (ed.), M. Dekker, New York (1993), 24.
3. N. S. Faithfull, *ibid.*, 569.
4. J. G. Riess, J. L. Dalfors, G. K. Hanna, D. H. Klein, M.-P. Krafft, T. J. Pelura and E. G. Schutt, *Biomat., Art. Cells & Immob. Biotech.*, **20**, 839 (1992).
5. S. Frokjaer, E. L. Hjorth, and O. Worts, in Liposome Technology, G. Gregoriadis (ed.), CRC Press, Boca Raton, Florida, Volume 1 (1984), 235.
6. S. Magdassi, M. Royz and S. Shoshan, *J. Disp. Sci. Technol.*, **12**, 69 (1991).
7. S. S. Davis, H. P. Round and T. S. Purewal, *J. Colloid Interf. Sci.*, **80**, 508 (1981).

EFFECTS OF FORMULATION, PROCESSING AND STORAGE PARAMETERS ON THE CHARACTERISTICS AND STABILITY OF PERFLUBRON EMULSION

Y. Ni, Ph.D., T. J. Pelura, Ph.D., T. A. Sklenar, R. A. Kinner and D. Song, Ph.D.
Alliance Pharmaceutical Corp., San Diego, California 92121

ABSTRACT

In this study, the effects of formulation, processing and storage parameters on perflubron (perfluorooctyl bromide; PFOB) emulsions were investigated. Emulsions with varying concentrations of perflubron and egg yolk phospholipid (EYP) were prepared with different processing parameters and placed at different storage temperatures. Their characteristics and stability were compared. The emulsion droplet growth rate was nearly proportional to the perflubron percentage in the range of 15-110% w/v. The initial droplet size of perflubron emulsions was inversely proportional to the concentration of EYP until a certain lower limit of droplet size was reached. The initial droplet size and droplet growth rate of perflubron emulsion were strongly dependent upon the processing parameters. The logarithmic value of the droplet growth rate decreased linearly with $1/T$ in the range of 5-40°C. The formulation and processing parameters are the key variables to be optimized to achieve better emulsion characteristics and stability.

INTRODUCTION

Oil-in-water emulsions containing perflubron and stabilized with EYP have potential applications as contrast agents and oxygen carriers [1, 2]. In this study, the effects of formulation, processing and storage parameters on perflubron emulsions were investigated.

MATERIALS AND METHODS

Emulsions with varying concentrations of perflubron and commercial EYP were prepared with a high-pressure homogenizer at different processing conditions. Perflubron percentage is reported in w/v. To convert into % v/v, the value of % w/v should be divided by 1.918 (the density of perflubron). The emulsions were terminally sterilized in a rotating autoclave at 121°C. Their characteristics and stability were compared after storage at 5, 30 and 40°C. ECHIP software (by ECHIP Inc., Delaware) was used in the experimental design, data analysis and contour plot preparation.

Droplet size distributions were determined by photosedimentation with a Horiba CAPA-700 instrument. The diameter used in this paper is volume-weighted, which is more sensitive in detecting the droplet size changes and the large droplets than the number-weighted diameter. The reported diameter is the adjusted value after removing the bar of fluorocarbon-free lecithin vesicles at the far right of the Horiba histogram [3].

RESULTS AND DISCUSSION

Effects of Perflubron/EYP on Droplet Size and EYP Efficiency

Influence of perflubron/EYP on droplet size. The initial diameters of sterile emulsion droplets with varying perflubron/EYP ratios are illustrated in Figure 1a. With a decrease of the perflubron/EYP ratio, i. e. an increase of the concentration of EYP, the initial droplet size of perflubron emulsion decreased until a certain lower limit of droplet size was reached.

EYP efficiency. The EYP efficiency η , which is defined as the percentage of the EYP used to form a monolayer at the perflubron/water interface to the total EYP amount, can be calculated with the above data. For a monodispersed emulsion with spherical droplets,

$$A = 6V/d \quad \text{.....(1)}$$

where A, V and d are the total surface area, total volume and diameter of the perflubron droplets. For a polydispersed emulsion, the total surface area can be estimated from equation 1. Then,

$$\eta = [6 * MW / (A_0 * N_{avo} * \rho)] * (R/d) \quad \text{.....(2)}$$

where MW is the molecular weight of EYP, A_0 is the average area per EYP molecule at the perflubron/water interface, N_{avo} is the Avogadro's number, ρ is the density of perflubron and R is the perflubron/EYP ratio.

Taking $A_0 = 60 \text{ \AA}^2$, the values of η are calculated and shown in Figure 1b. It can be seen that there is an optimal range for the perflubron/EYP ratio (R). When R is below 15, η decreases almost proportionally with a decrease of R, indicating an excess of EYP. When R is above 30, η levels off, but the diameter increases proportionally with an increase of R.

Perfluorocarbon Emulsions and Ostwald Ripening

Lifshits and Slezov [4] studied the grain growth by Ostwald ripening in supersaturated solid solutions (without taking surfactant interfacial layer into account),

$$d/dt (r^3) = 8\gamma V_m CD / 9RT \quad \text{.....(3)}$$

where t is the time, r the mean grain radius, γ the interfacial tension, V_m the molar volume of disperse phase, C and D the solubility and diffusion coefficient of the disperse phase in the continuous phase. They have assumed the "interaction" between grains negligible (i.e. the system is dilute) and the degree of supersaturation to be small. There are no concentration and weak T dependence on grain growth in equation 3. Higuchi and Misra [5] derived a similar expression as applied to emulsions.

Davis et al. [6] suggested that Ostwald ripening could be the primary cause of aging for perfluorocarbon (PFC) emulsions. Kabal'nov et al. [7] observed the linear increase of droplet volume of PFC/Proxanol emulsions with time and applied Lifshits' expression to them. Varescon et al. [8] observed that droplet volume increased linearly with time in perfluorodecalin/Pluronic F-68 and other concentrated PFC emulsions, thus allowing the description of emulsion's stability by a single figure for a given PFC at a given temperature.

Droplet Growth in Perflubron Emulsions

Emulsion droplet growth rate. We observed that plotting the cube of the volume-weighted diameter of emulsion droplets vs. time gave a straight line, as shown in Figure 2a for a 90% w/v perflubron-4% w/v EYP emulsion. For convenience, the "Stability Parameter" S is used to represent the emulsion droplet growth rate. "S" is defined as the slope of linear fit of the cube of the diameter (volume-weighted) vs. time, in $\mu\text{m}^3/\text{month}$ [9].

The storage temperature dependence of S. It has been observed that S is proportional to $\exp(-E/RT)$ in the range of 5 to 40°C. E is apparent activation energy. Plotting $\log(S)$ vs. $1/T$ gave a straight line as is shown in Figure 2b. Krafft et al. have studied the influence of storage temperature on droplet growth rate with concentrated perfluorodecalin emulsions [10].

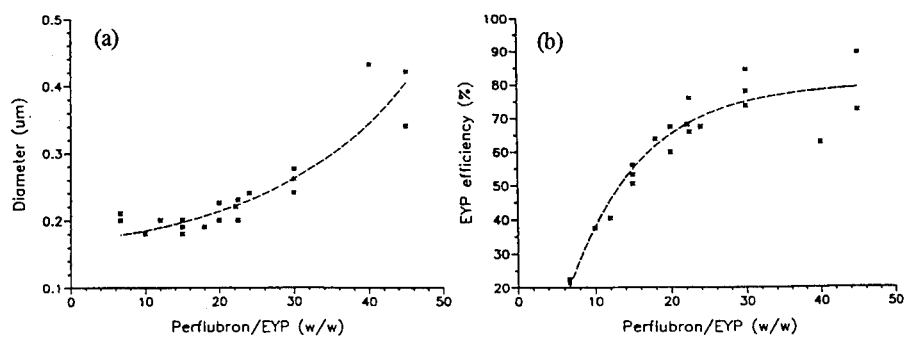

FIGURE 1. Influences of perflubron/EYP on (a) emulsion droplet size and (b) EYP efficiency.

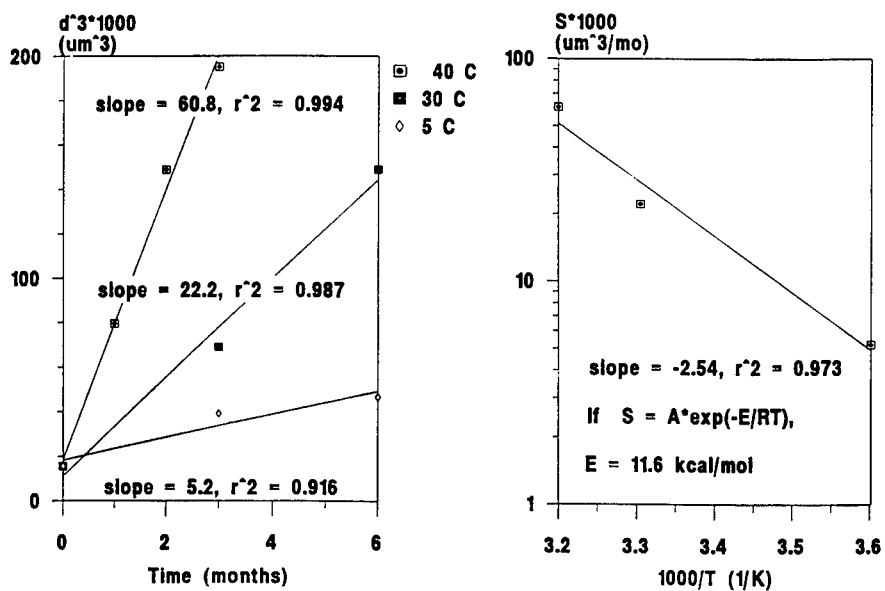

FIGURE 2. Effects of storage temperature on (a) droplet size and (b) droplet growth rate.

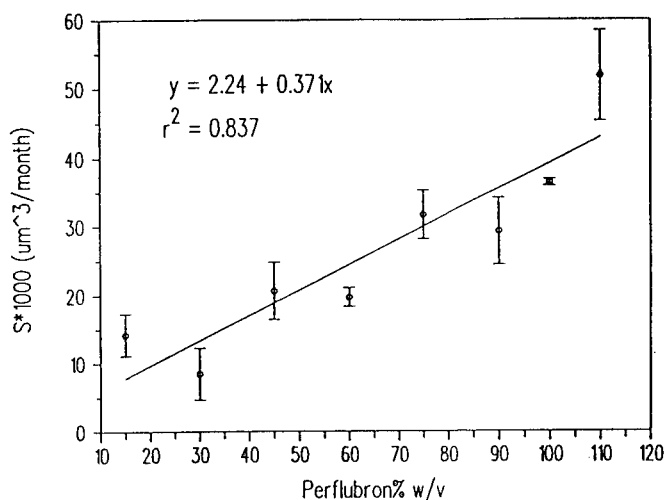

FIGURE 3. Influence of perflubron% on emulsion droplet growth rate.

The perflubron% dependence of S. The S values of 15-110% w/v perflubron emulsions (perflubron/EYP = 22.5) stored at 40°C vs. perflubron% are shown in Figure 3. The emulsion droplet growth rate was nearly proportional to the perflubron%. The effects of a finite volume fraction of disperse phase on the coarsening behavior and droplet growth rate of two-phase systems have been discussed by Voorhees [11].

Simultaneous Study of Formulation and Process Parameters

Experimental design with ECHIP. The independent variables (and their ranges) are: homogenization temperature T (30-60°C), homogenization pressure P (3000-9000 psi), perflubron% w/v (40-90), perflubron/EYP (22.5-30 w/w) and number of passes (4-10). Responses (i.e. droplet growth rates at 40°C as well as initial droplet diameters) were fitted with a quadratic model of the above five independent variables.

The effects of perflubron% and temperature on S. The contour plots of "S at P = 4500 psi, perflubron/EYP = 26.3, pass = 7" are shown in Figure 4. The S value increased proportionally with the perflubron%, which agrees with the above observation.

The effects of pressure and temperature on S. In the contour plots of "S at perflubron% = 90, perflubron/EYP = 26.3, pass = 7" (Figure 5), the droplet growth rate decreased appreciably with a decrease of pressure. A similar trend was observed for 100% w/v perflubron emulsions [12]. From Figures 4 and 5, it was seen that the S value varied quadratically with T to some extent.

The effects of number of passes and pressure on S. Figure 6 indicates an optimal combination of number of passes and pressure. This may be explained by "overwork", which refers to excess process energy. To maintain optimal process energy, increase of one of the energetic variables requires reduction of the other.

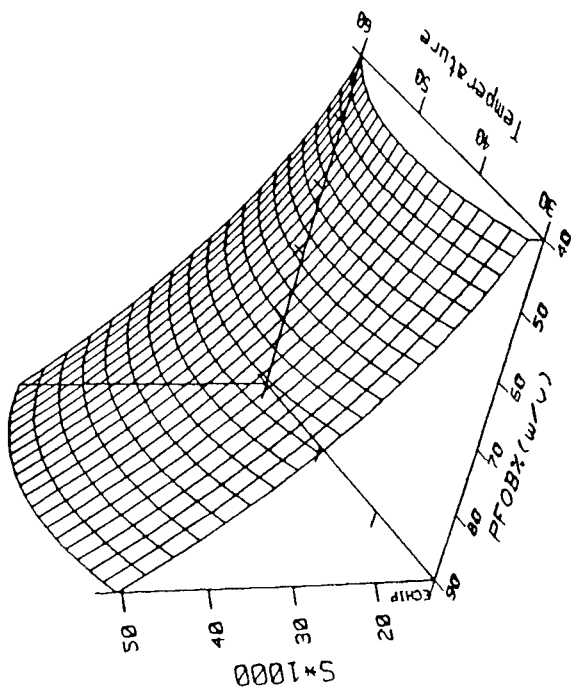
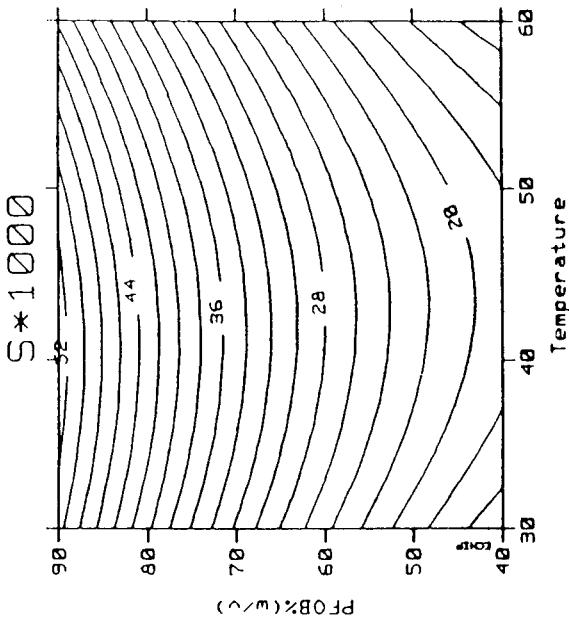

FIGURE 4. Droplet growth rate at P = 4500 psi, perfubron/EYP = 26.3 and pass = 7.

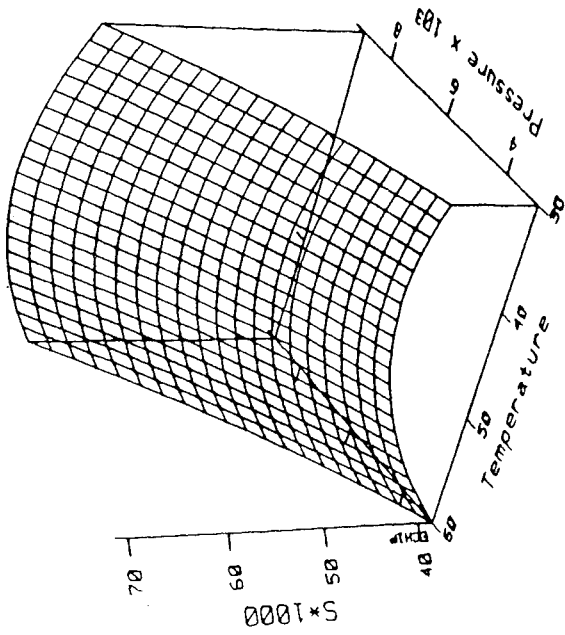
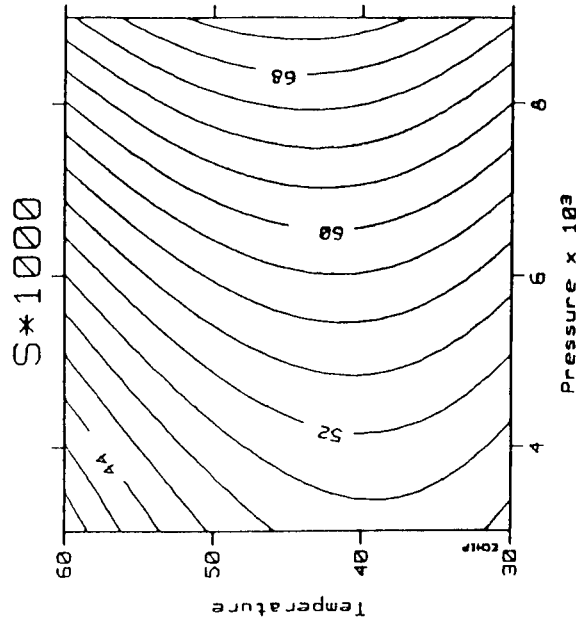

FIGURE 5. Droplet growth rate at perfubron% = 90, perfubron/EYP = 26.3 and pass = 7.

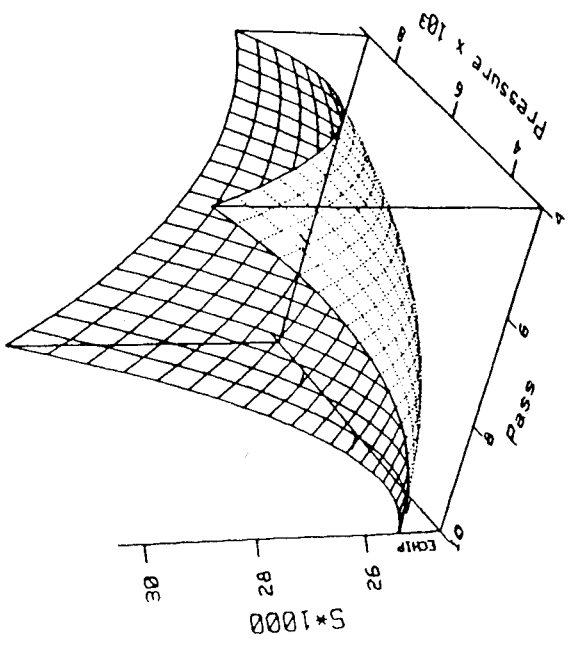
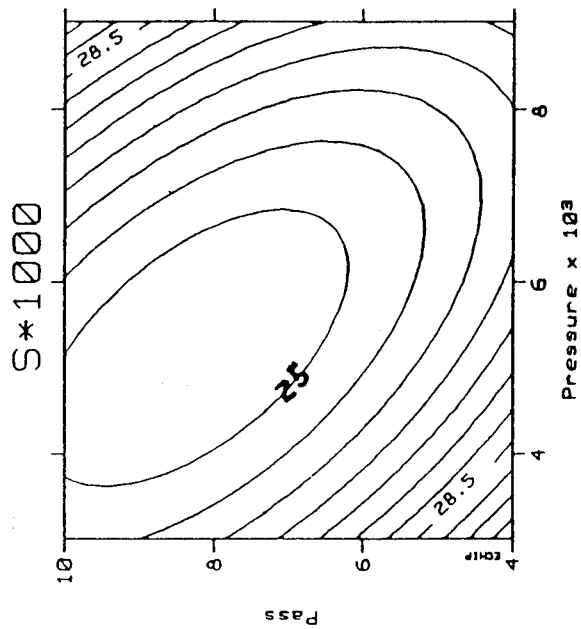

FIGURE 6. Droplet growth rate at perflubron% = 60, perflubron/EYP = 24.4 and T = 30°C.

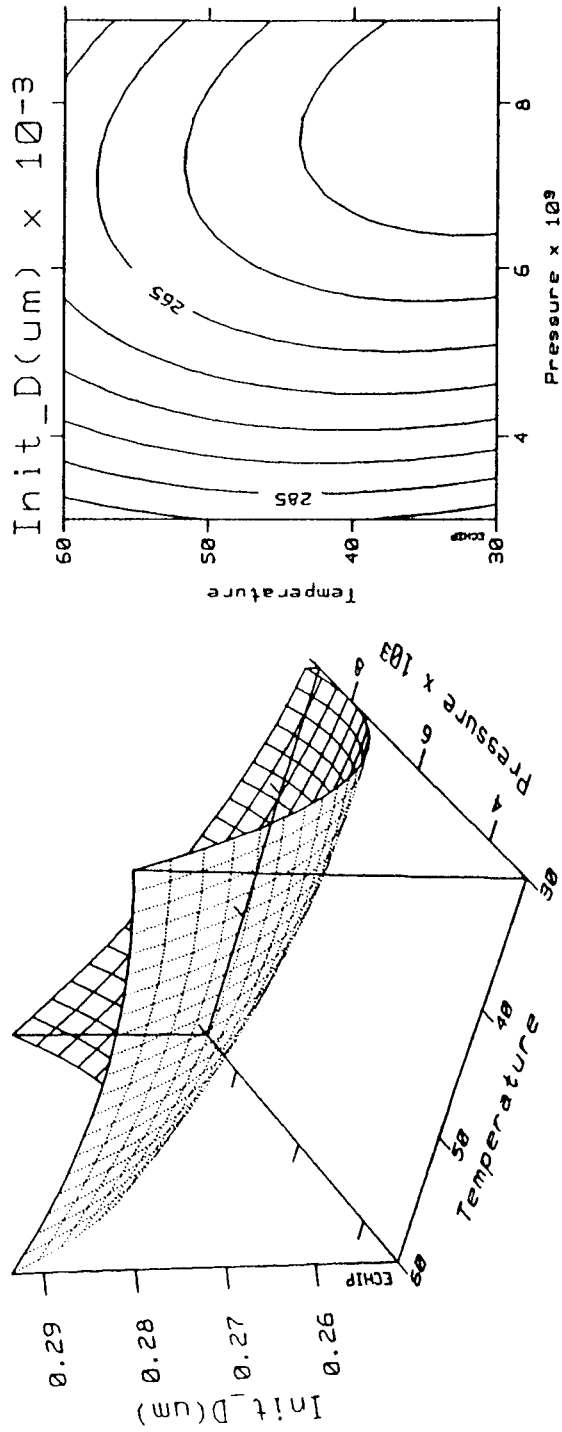

FIGURE 7. Initial diameter at perflubron% = 60, perflubron/EYP = 22.5 and pass = 7.

The effects of P and T on the initial droplet size. Figure 7 shows that a minimal initial droplet size was found at higher pressures and lower temperatures. The effects of P and T, however, were not substantial. The initial droplet size only varied about 0.04 μm from the minimum (about 0.25 μm) to the maximum (about 0.29 μm).

REFERENCES

1. J. G. Riess, *Vox Sang*, **61**, 225 (1991).
2. J. G. Riess, J. L. Dalfors, G. K. Hanna, D. H. Klein, M.-P. Krafft, T. J. Pelura and E. G. Schutt, *Biomat., Art. Cells & Immob. Biotech.*, **20**, 839 (1992).
3. M.-P. Krafft, J.-P. Rolland and J. G. Riess, *J. Phys. Chem.*, **95**, 5673 (1991).
4. I. M. Lifshits and V. V. Slezov, *Sov. Phys. JETP*, **35**, 331 (1959).
5. W. I. Higuchi and J. Misra, *J. Pharm. Sci.*, **51**, 459 (1962).
6. S. S. Davis, T. S. Purewal, R. Buscall, A. Smith and K. Choudhury, *Proc. Int. Conf. on Colloid Interf. Sci.*, Academic Press: New York, **2**, 265 (1976).
7. A. S. Kabal'nov, Yu. D. Aprosin, O. B. Pavlova-Verevkina, A. V. Pertsov and E. D. Shchukin, *Kolloidn. Zh.*, **48**, 27 (1986).
8. C. Varescon, C. Arlen, M. Le Blanc and J. G. Riess, *J. Chim. Phys.*, **86**, 2111 (1989).
9. Y. Ni, T. J. Pelura and D. Song, Droplet Size Stability of PFC Emulsions, p. 72, 65th Colloid and Surface Science Symposium, Oklahoma, June 1991.
10. M.-P. Krafft, M. Postel, J.-G. Riess, Y. Ni, T. J. Pelura, G. K. Hanna and D. Song, in Blood Substitutes and Oxygen Carriers, T. M. S. Chang (ed.), M. Dekker, New York (1993), 633.
11. P. W. Voorhees, *J. Stat. Phys.*, **38**, 231 (1985).
12. Y. Ni, D. H. Klein and T. J. Pelura, *Biomat., Art. Cells & Immob. Biotech.*, **20**, 869 (1992).

**ANALYSIS OF OSTWALD RIPENING IN FLUOROCARBON EMULSIONS
BY SEDIMENTATION FIELD-FLOW FRACTIONATION**

R.A. Arlauskas, D.H. Klein, and J.G. Weers
Alliance Pharmaceutical Corp., San Diego, California, U.S.A.

ABSTRACT

The Ostwald ripening mechanism has been studied using sedimentation field-flow fractionation (SdFFF). It has been shown that significant partitioning between different sized droplets occurs for two component disperse phase emulsions, when one of the components is virtually insoluble in the continuous phase.

INTRODUCTION

Physical stability is an essential prerequisite for fluorocarbon emulsions destined for medical applications [1-3]. Ostwald ripening (also known as emulsion transcondensation or molecular diffusion) is the primary mechanism of growth in small particle fluorocarbon emulsions. Ostwald ripening results from the isothermal distillation of fluorocarbon molecules from one droplet to another through the continuous phase. The driving force for Ostwald ripening is the small difference in oil solubility in the continuous phase which occurs as a consequence of capillarity. According to Kelvin's law, the disperse phase vapor pressure increases with increases in the radius of curvature of the droplets. In the case of an oil droplet with minimal solubility in the continuous phase, the Kelvin equation can be written in terms of solubility instead of vapor pressure, viz.

$$RT \ln (C_a/C_0) = 2\gamma V/a \quad (1)$$

where C_a is the solubility of a droplet with radius a , C_0 the solubility of the bulk

oil, γ , the interfacial tension, and V , the molar volume. Very small droplets will be more soluble than the bulk oil phase, thereby, making the small droplets thermodynamically unstable. The smaller droplets will tend to dissolve and the dissolved oil will subsequently diffuse into the larger droplets.

The kinetics for particle growth by Ostwald ripening are most often described in terms of Lifshitz-Slyozov-Wagner (LSW) theory [4]. LSW theory relates that for a single component disperse phase, the cube of the mean particle radius increases linearly with time at a rate, ω .

$$\omega = d/dt (a)^3 = 8\gamma V C_a D / 9RT \quad (2)$$

where, D is the diffusion coefficient of the disperse phase substance in the continuous phase, R , is the molar gas constant, and T , the absolute temperature.

To counteract emulsion growth via Ostwald ripening, Higuchi and Misra [5] proposed the addition of a second disperse phase component which is insoluble in the continuous phase. In this case, significant partitioning of the two disperse phase components will occur between different sized droplets upon storage, with the low water solubility component expected to be concentrated in the smaller droplets. Emulsion stabilization occurs because of a balance of two effects. The partitioning of fluorocarbon components between different sized droplets leads to decreased solubility for the smaller droplets according to Raoult's law. This compensates for the difference in chemical potentials between the main fluorocarbon component and the minor component which was caused by the difference in capillary pressures. When the concentration effect completely compensates the capillary one the mass transfer terminates, and the rate of Ostwald ripening becomes equal to zero. The emulsion growth rate, ω_{ab} , for a two component disperse phase is given by:

$$\omega_{ab} = 1 / [(\phi_a/\omega_a) + (\phi_b/\omega_b)] \quad (3)$$

where a and b designate fluorocarbon a and b respectively, and ϕ is the volume fraction of the component in the disperse phase.

In this study, we examine the kinetics of particle growth in concentrated emulsions containing two disperse phase components chosen from the same chemical family, viz. perfluorohexyl bromide (PFHB), perfluorooctyl bromide (perflubron, PFOB), and perfluorodecyl bromide (PFDB). We also show preliminary data concerning the partitioning of fluorocarbons in two-component disperse phase emulsions via sedimentation field-flow fractionation (SdFFF).

SdFFF is an unusual particle sizing technique which affords a unique opportunity to determine the particle size distribution of fluorocarbon emulsions as well as to collect monosized fractions of the emulsion. These fractions can then be subsequently analyzed by an analytical method such as gas chromatography to characterize and quantitate the fluorocarbon components of the particles. In this way it is possible to monitor the migration of fluorocarbons, over time, from particles of one droplet size to another.

MATERIALS AND METHODS

Concentrated (90% w/v fluorocarbon emulsions) containing various ratios of PFHB, PFOB and PFDB were manufactured under high pressure homogenization. Emulsions were stabilized versus coalescence via addition of 4% w/v egg yolk phospholipid (EYP). The emulsions were placed on an accelerated particle stability program at 40 °C.

Fractionation experiments were performed on a model S101 SdFFF (FFFractionation Inc., Salt Lake City, Utah). The instrumental conditions have been described previously [5]. At various timepoints, the individual fluorocarbon concentrations of a set of monosized fractions were determined by injecting 100 μ l of the neat emulsion and collecting fractions across the range of the particle size distribution. The fluorocarbons were extracted from these fractions into isooctane and analyzed by gas chromatography (electron capture detector) against external standards.

RESULTS AND DISCUSSION

Figure 1 presents linear plots of the cube of the droplet diameter vs. time for concentrated fluorocarbon emulsions. The primary fluorocarbon is PFOB, while the minor components are either PFHB or PFDB. The linear plots are consistent with an Ostwald ripening growth mechanism. The "S" values represent emulsion growth rates in units of $\mu\text{m}^3/\text{month}$. Addition of as little as 1% w/w PFDB decreases the growth rate of PFOB emulsions by greater than three times. Addition of 10% w/w PFDB leads to an order of magnitude decrease in the particle growth rate. Conversely, addition of 36% w/w PFHB leads to a dramatic decrease in stability of the PFOB emulsion with an increase in growth rate by a factor of 2.5. The water solubilities of the three fluorocarbon components would

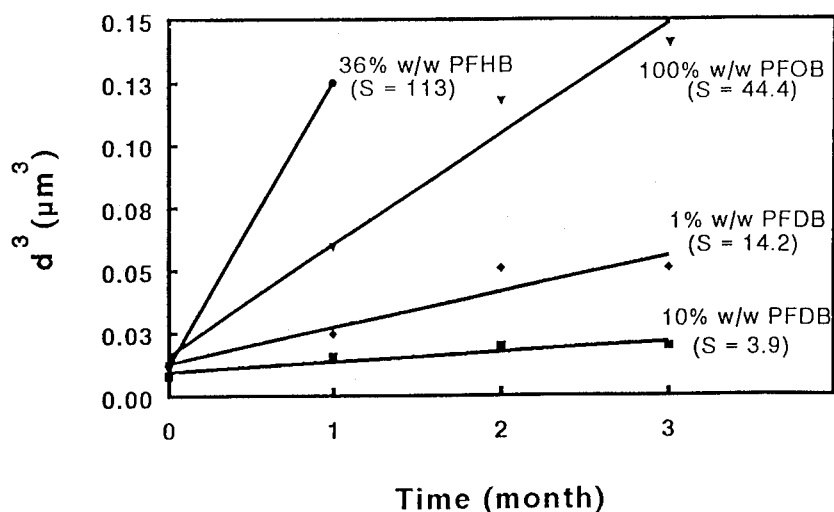

FIGURE 1. Diameter cubed vs. time for a series of concentrated fluorocarbon emulsions. Linear dependence of curves indicative of an Ostwald ripening mechanism.

be expected to decrease in the order PFHB > PFOB > PFDB, consistent with the changes in physical stability noted.

SdFFF fractograms obtained for a concentrated emulsion containing a 90/10 w/w ratio of PFOB/PFDB are illustrated in Figure 2. Shown are fractograms after 1 and 4 months of storage at 40 °C. The shoulder which appears next to the initial sharp void volume peak is due to the presence of free lipid vesicles. The larger sized droplet population is assigned to the fluorocarbon emulsion droplets. The emulsion peak after 1 month has a median diameter of 0.23 μm. After 4 months storage, the distribution has grown and broadened to a median diameter of 0.31 μm.

The partitioning of the PFOB and PFDB components in various sized emulsion droplets is illustrated in Figure 3. Shown are the SdFFF fractogram and PFOB/PFDB w/w ratio as obtained by gas chromatography for a 90/10 w/w PFOB/PFDB fluorocarbon mixture (bulk ratio of PFOB/PFDB = 9). This would also be the ratio of components expected in emulsion droplets in the absence of molecular diffusion. After one month of storage, the sample has evolved such that

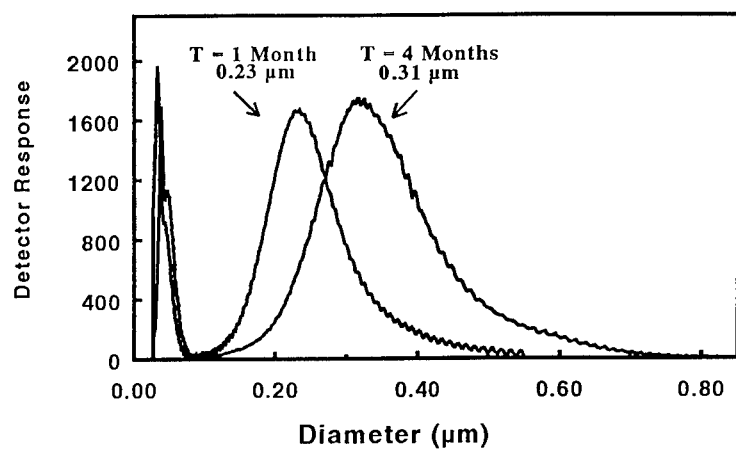

FIGURE 2. SdFFF fractograms obtained for a concentrated fluorocarbon emulsion containing a 90/10 w/w ratio of PFOB/PFDB. The median diameter increases from 0.23 to 0.31 μm between 1 and 4 months of storage at 40 $^{\circ}\text{C}$.

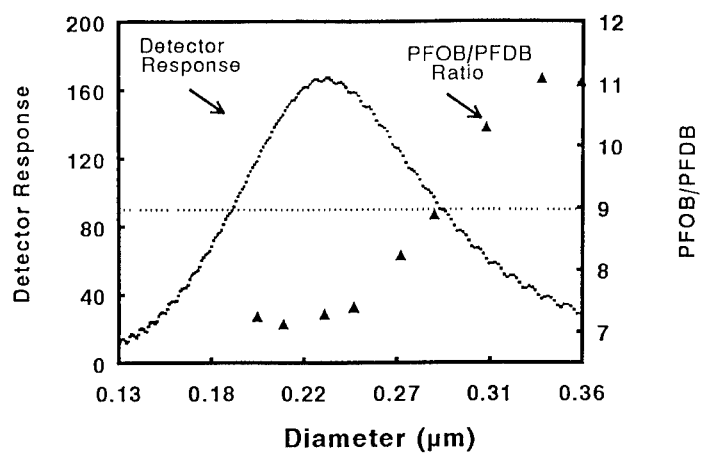

FIGURE 3. Partitioning of fluorocarbon observed in fluorocarbon emulsions containing two disperse phase components ($t = 1$ month at 40 $^{\circ}\text{C}$). The small droplets are enriched in the low solubility component.

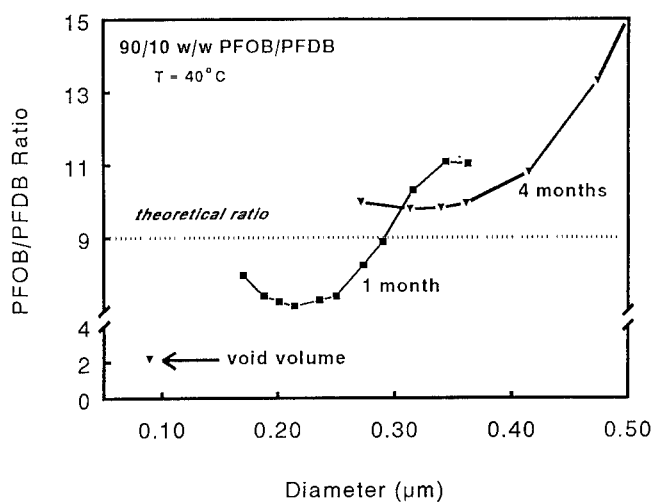

FIGURE 4. Effect of storage on droplet partitioning in fluorocarbon emulsions containing two disperse phase components. With time, the larger droplets are increasingly concentrated in the high vapor pressure, high water solubility component.

the smaller droplets ($< 0.24 \mu\text{m}$) have a PFOB/PFDB ratio of ca. 7. The smaller droplets are, therefore, enriched by ca. 2.5% in PFDB over bulk compositions. On the other hand, larger droplets (e.g. $0.36 \mu\text{m}$) have a PFOB/PFDB of ca. 11, i.e. significantly enriched in the high vapor pressure component.

Figure 4 shows a comparison of the PFOB/PFDB ratio in various sized emulsion droplets after 1 and 4 months of storage at 40°C . This data provides the first direct proof of component partitioning during mass transfer between different sized droplets in two component disperse phase fluorocarbon emulsions. After 4 months the larger droplets are enriched to an even greater extent than at 1 month. The small droplets have shrunk to the extent that they are now eluted in the void volume. The PFOB/PFDB ratio in the void volume suggests that approximately 1/3 of the small droplet fluorocarbon composition is now PFDB.

CONCLUSIONS

The linear plots of d^3 vs. time, and the partitioning of PFOB and PFDB in droplets containing two fluorocarbon components are consistent with an Ostwald

ripening growth mechanism. SdFFF measurements provide the unique opportunity to follow mass transfer processes in perfluorocarbon emulsions.

REFERENCES

- [1] J.G. Riess, *Vox. Sang.* **61**, 225 (1991).
- [2] J.G. Riess In: "*Blood Substitutes and Oxygen Carriers*", T.M.S. Chang, Ed.; M. Dekker, New York, 1993, p. 24-43.
- [3] N.S. Faithfull In: "*Blood Substitutes and Oxygen Carriers*", T.M.S. Chang, Ed.; M. Dekker, New York, 1993, p. 569-576.
- [4] A.S. Kabalnov, and E.S. Shchukin, *Adv. Colloid Interface Sci.* **38**, 69 (1992).
- [5] W.I. Higuchi, and J. Misra, *J. Pharm. Sci.* **51**, 459 (1962).
- [6] R.A. Arlauskas, D.R. Burtner, and D.H. Klein In: "*Chromatography of Polymers*"; ACS Symposium Series 521; T. Provder, Ed.; American Chemical Society: Washington DC., 1993; p. 1-12.

CONCENTRATED EMULSIONS OF PERFLUBRON
IN AQUEOUS MEDIA

S.S. Habif, H.L. Rosano, and C.B. Oleksiak
Department of Chemistry
The City College of the City University of New York
Convent Avenue at 138th Street
New York, New York 10031 - U.S.A.

ABSTRACT

Flocculation of o/w emulsions consisting of a perfluorochemical (PFC) emulsified by either phospholipids or decaglyceroldioleate (10-2-O) was assessed both by direct observation and through photon correlation spectroscopy (PCS) and viscoelasticity measurements in unsteady oscillatory flow. Flocculation gives rise to emulsion instability but can be prevented (a) by the addition of a negatively charged surfactant to either phosphatidylcholine (PC) or 10-2-O, respectively the zwitterionic phospholipid and the nonionic surfactant used as primary emulsifiers, or (b) by using a saccharide solution as the continuous phase. The study indicates that both electrostatic (Coulombic) repulsive forces and hydration (steric) forces play a role in preventing flocculation. Various minor components of the egg yolk phospholipids (EYP) used in commercial emulsion preparation probably stabilize the emulsion by increasing both electrostatic and hydration repulsion.

INTRODUCTION

Considerable interest in perflubron (PFOB) emulsions has arisen from their numerous potential biomedical applications,

as (among other things) imaging solutions and oxygen-carrying solutions (i.e., red blood cell substitutes) [1, 2]. The objective of the present work was to determine the factors involved in the stability of PFOB/saline emulsions with egg yolk phospholipids (EYP) as an emulsifier.

MATERIALS AND METHODS

Phospholipon 90H (PL) was purchased from American Lecithin Company (Danbury, CT) and was used without further purification. Perflubron (perfluorooctyl bromide, PFOB) was generously supplied by Alliance Pharmaceutical Corp. (San Diego, CA) and was redistilled twice before use. Decaglyceroldioleate (10-2-O) was a gift from Karlshamns USA Inc. (Columbus, OH). Dipalmitoyl phosphatidylcholine (DPPC), stearylamine (99%) (SA) and cholesteryl hemisuccinate (tris salt) (CHS) were purchased from Sigma Chemical Company. All other chemicals were purchased from Fisher Scientific.

Emulsion preparation and composition

The emulsifier is first dispersed in the aqueous phase by magnetic stirring at 65-70°C until a milky dispersion is obtained. Then the mixture is submitted to mechanical work (3 min./13,500 rpm/65°C) in an Ultra-Turrax (UT) T25 (IKA Works, Inc., Cincinnati, OH) fitted with a dispersing tool S25 KG-25 F. The oil is added and the system is mixed (5 min./13,500 rpm/65°C) until it yields a homogeneous preemulsion; this preemulsion is fed into a microfluidizer (MF) M110-T (Microfluidics Corp., Newton, MA) (10,000 psi/5-7 passes) and the resulting emulsion, contained in glass vials with rubber stoppers and crimped aluminum seals, is sterilized in a static autoclave (AMSCO) (121°C/20 psi/15 min.). The total volume of each emulsion sample is 300 ml. A series of emulsions was made using the process described above. The concentrations of dispersed phase and continuous phase were kept constant, 45%

v/v and 55% v/v respectively, as was the emulsifier concentration, 50mM.

RESULTS AND DISCUSSION

1. PFOB/EYP/saline emulsion characterization

A practical formulation consists of PFOB dispersed in a saline solution with EYP (commercially available egg yolk phospholipids) as an emulsifier. This emulsion has been found to be stable over four years at 5°C [3] (the criteria used to assess the emulsion stability are (a) no phase separation, (b) no, or very little, coalescence, and (c) no flocculation) and has been characterized [4] as being made of (a) PFOB droplets (about 250 nm diameter) encapsulated in a phospholipid monolayer and (b) PFOB-free phospholipid vesicles (80-100 nm diameter). Once the emulsion is made, a necessary condition for its stability is the presence of a structured interfacial film. Compression isotherms of a monolayer of EYP show that the film has a high collapse pressure (45 mN/m) and a high surface potential (+400 mV for a molecular surface area of 50 Å²) and that the compression/decompression curves have no, or very little, hysteresis: all evidence of a structured film. Particle-size measurement (PCS) and transmission electron microscopy (TEM) study show that no coalescence or flocculation occurred [4]. Viscoelastic measurements also show no evidence of flocculation: the low specific viscosity (11 cP) decreases regularly (a single slope) with increasing shear rate due to deformation and alignment of the droplets with the flow, followed by a plateau when a maximum deformation is reached (figure 1). The elasticity follows the same pattern when the shear strain is increased. Our purpose is to determine why EYP is capable of producing stable emulsions of PFOB.

EYP has a complex and variable composition and is very sensitive to oxidation. Accordingly, we decided to use an alternative emulsifier as a simpler model for our system.

2. 10-2-O and saturated PC as a replacement for EYP

Pure phospholipids (DPPC) and 10-2-O dramatically reduce the PFOB/saline interfacial tension (from 50 mN/m between pure PFOB and saline to 1 mN/m and 6 mN/m in the presence of interfacial films of DPPC and 10-2-O, respectively), with resultant lowering of the free energy required in the emulsification process, and provide the structured interfacial film necessary for emulsion stability, as evidenced by monolayer studies [5]. Nevertheless, an emulsion of PFOB in saline made with pure PL is unstable. Direct observation of the emulsions shows a settling of a gel-like phase with a high resistance to the flow (thixotropic behavior) at the bottom of the vial. The flocculation phenomenon was confirmed by viscoelastic measurements (figure 1). With an increase in shear strain, the elasticity (stored energy) decreases following a two-slope pattern: the initial decrease in elasticity (first slope) corresponds to a breakage of the flocs, with a subsequent additional decrease in elasticity (second slope) resulting from the reduced ability of single droplets to store energy - itself a result of their stress-induced flattening. The curve of the specific viscosity-versus-shear rate follows the same pattern. First, the decrease in specific viscosity with increased shear rate is due to the breakage of the flocs; then, once the flocs are broken, the single droplets align themselves with the flow, resulting in a lowering of the specific viscosity. This system exhibits high specific viscosity values (100 to 2,000 cP) that make it unsuitable for intravenous injection. PFOB emulsions prepared with 10-2-O in a 5% dextrose solution did not flocculate, however. We were prompted by our finding that an uncharged interface yields flocculation and that the presence of saccharides in the continuous phase prevents flocculation to study the role of electrostatic and hydration forces in preventing flocculation; we examined the effects of charging the interface and of using a saccharide solution as a continuous phase, with the results reported below.

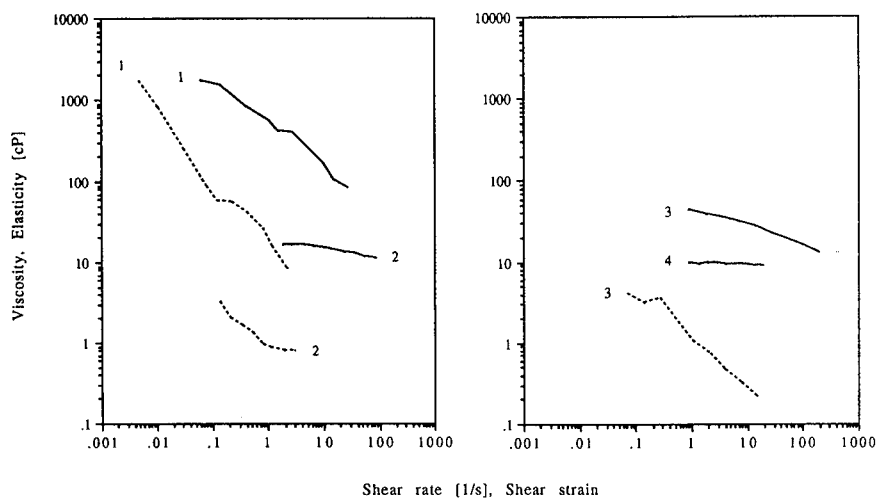

FIGURE 1 — specific viscosity (cP) versus shear rate (1/s) and --- elasticity (cP) versus shear strain of (1) PFOB/PL/saline, (2) PFOB/EYP/saline, (3) PFOB/PL/5% dextrose solution, and (4) PFOB/(PL : CHS (9 : 1, mol : mol))/saline at $f = 2$ Hz and 25°C .

3. Model for PFOB/EYP/saline emulsions

The great improvement in emulsion stability obtained by charging the interface shows the importance of electrostatic forces in preventing flocculation. But a negatively charged interface (e.g., CHS) (with highly hydrated positive counterions) yielded much more stable systems than a positively charged interface (e.g., SA) (with anionic counterions that are less hydrated than cations), showing the contribution of hydration forces in stabilizing the emulsion. This was confirmed by the stabilizing effect of saccharides (e.g., dextrose) adsorbed at an uncharged interface (figure 1).

4. Conclusions

Flocculation resulting from attractive forces can be prevented by the combined effects of electrostatic and

hydration repulsive forces. EYP is capable of producing stable emulsions of PFOB because EYP has a balanced composition: (a) major phospholipids (PC, phosphatidyl ethanolamine) provide a structured interfacial film and (b) some minor components prevent flocculation by providing a strong hydration shell around the emulsion droplets; these include acidic phospholipids (e.g., phosphatidyl serine, phosphatidyl glycerol) and highly hydrated compounds (e.g., phosphatidyl inositol). Systems prepared with PL and a negatively charged additive (such as CHS) that forms a mixed film with PL but does not affect the film's molecular packing offer a convenient model for understanding EYP systems.

ACKNOWLEDGEMENTS

CBO and SSH gratefully acknowledge the financial support provided by General Foods-Kraft and Alliance Pharmaceutical Corporation, San Diego, California.

REFERENCES

1. J.G. Riess. In *Blood Substitutes and Oxygen Carriers*, T.M.S. Chang (ed), pp. 24-43, M. Dekker, New York (1993).
2. N.S. Faithfull. In *Blood Substitutes and Oxygen Carriers*, T.M.S. Chang (ed), pp. 569-576, M. Dekker, New York (1993).
3. J.G. Riess, J.L. Dalfors, G.K. Hanna, D.H. Klein, M.-P. Krafft, T.J. Pelura, and E.G. Schutt. *Biomat., Art. Cells and Immob. Biotech.*, 20, 839-842 (1992).
4. H.L. Rosano, S.S. Habif, C.B. Oleksiak, T.J. Pelura, and J.L. Cavallo. In *Surfactants in Solution* (Mittal, K.L. and Shah, D.O., eds.), Vol. 11, pp. 431-456, Plenum Press, New York (1991).
5. S.S. Habif, P.E. Normand, C.B. Oleksiak, and H.L. Rosano. *Biotechnol. Prog.*, 8, 454-457 (1992).

APPLICATION OF FLUOROCARBON EMULSIONS AS COMPONENTS OF COSMETICS AND MEDICAL OINTMENTS

O.E. Oxynoid, D.P. Sydliarov, Yu.D. Aprosin, and V.V. Obraztsov

Research Center, NIZAR Pharm.Co., New Ipatovka,4, Moscow and
Institute of Cell Biophysics, Pushchino, Russia

ABSTRACT. Localization and accumulation of perfluorochemicals (PFCs) in the skin and internal organs of rats after prolonged surface application of the concentrated PFC emulsion, fluorogel, have been studied by electron microscopy and gas-chromatography. The PFC concentration in skin was about 0.03-0.04 mg per 1 g of tissue. Few aggregates of emulsion particles were detected in derma. The oxygen-dependent favorable effect of fluorogel treatment of thermic burned skin and wound surface was found.

INTRODUCTION

Lately an interest has grown to an application of PFC emulsions in cosmetics and dermatology [1,2], in addition to their traditional medical use as blood substitutes [3,4]. PFC emulsions containing oxygen are considered to be able to support respiration and improve skin metabolism [5]. It is not inconceivable that PFC emulsions, besides their contributing to gas transport, could have a beneficial effect on the structure and functions of skin, preventing its aging, protecting it from injurious environmental factors, activating reparative system, etc.

The present work reports investigations carried out in two directions:

1. In order to detect a mechanism of interaction of PFC emulsions with skin cells, accumulation and localization of fluorocarbons in rat skin after surface application of a PFC emulsion have been studied using electron microscopy and gas-liquid chromatography.

2. To estimate a therapeutic efficacy of the fluorocarbon emulsion, its influence upon the speed of repair of surgical wounds and thermal burns has been investigated.

MATERIALS AND METHODS

Male Wistar rats, weighing 200-250 g, were used. The composition of the concentrated PFC emulsion, called fluorogel, was as follows:

PFCs *	55 ml
Proxanol 268 (analog of Pluronic F 68)	5.5 g
Glycerol	0.8 g
D-Sorbitol	1.6 g
1,2-Polypropylene glycol	0.5 g
Tocopherol acetate	0.5 g
2-Bromo-2-nitro-1,3-propanediol	0.05 g
Water	to 100 ml
Particle diameter(average)	150 nm

* - a mixture of purified PFCs containing 80% of perfluorodecalin (PFD).

When investigating the accumulation of PFCs in the animal's skin, 0.1 g of the emulsion was applied on the 2x2 cm shaven area of the rat's skin. To examine its therapeutic efficacy, the same dose of emulsion was spread on the surface of superficial uninfected surgical wounds and on the surface of thermal III-rd degree burns with an equal damaged area.

The emulsion was put immediately after skin damaging, and, subsequently, every day for 3 days. Oxygen-dependent effects were investigated during a 2-3 hours exposure of the animals to an atmosphere containing 20 and 76% O₂ immediately after spreading the emulsion onto the damaged skin area. The effect of the emulsion upon the regenerative process was compared to that of traditional biostimulating preparations: methyluracil and solkoseryl (protein-free extract from bovine blood).

RESULTS

The accumulation of PFCs in skin after a single application of fluorogel onto the skin surface is shown in Fig. 1. The content of PFD in skin did not exceed 0.03-0.04 mg per 1 g of skin. Insignificant amounts of fluorocarbons in the skin, as determined by gas-liquid chromatography, were revealed by electron microscopy as well (data not presented). The PFC emulsion was observed on the surface of the skin as aggregates of electron transparent particles of 100-250 nm in size. No such structures were found in the thickness of the epidermis. Few particle aggregates were found in the deep derma. The aggregates were localized in different sites: intercellular space of connective tissue, processes of connective tissue cells, cytoplasm of cells placed close to collagenous fibrils and processes of cells that form a hair follicle coating.

After prolonged (30 days) daily application of the emulsion onto the skin surface, no accumulation of PFCs was revealed in either the skin or the organs of the animals. The largest quantities of PFCs were found in the spleen and liver and were of 0.04 and 0.03 mg of PFD per 1 g of tissue, respectively.

The electron micrographs obviously demonstrate the absence of changes in cell ultrastructure of both the rat skin epidermis and derma in the areas submitted to prolonged application of fluorogel. However, keratinocytes appeared to be slightly stimulated: activation of their nuclei was manifested by the appearance of active nucleoli.

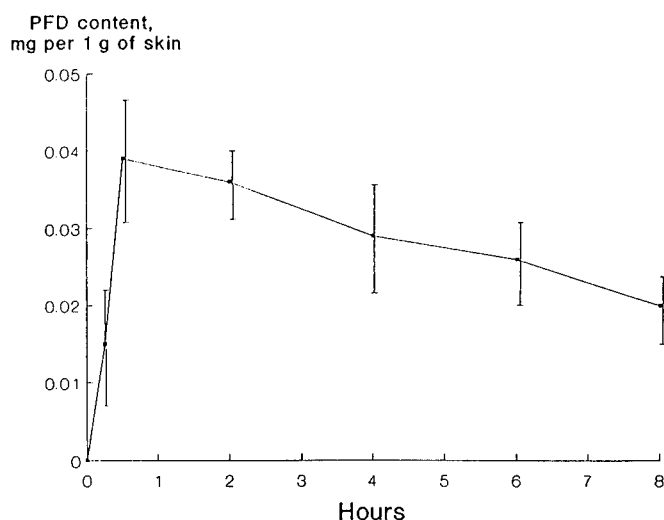

FIGURE 1. Accumulation of PFD in the rat skin after a single application of fluorogel. Means and SEM are shown, n=3.

TABLE I. Efficacy of fluorogel, methyluracil and solkoseryl in the treatment of surgical wounds exposed to an atmosphere containing 20 and 76% of oxygen (n=10).

Drugs	20 % O ₂		76 % O ₂	
	wound repair, days	acceleration	wound repair, days	acceleration
Control	21.5±0.5	--	20.4±0.5	--
Solkoseryl	20.3±0.7	5.6%	18.7±0.4	8.3%
Methyluracil	15.8±0.3	26.5%	16.5±0.2	19.1%
Fluorogel	18.0±0.5	16.3%	16.0±0.2	21.6%

TABLE II. Comparative efficacy of fluorogel and PFD in the treatment of wounds exposed to an atmosphere containing 76% O₂

Drugs	wound repair, days	acceleration
Control	21.4±0.5	--
Fluorogel	16.8±0.3	21.5%
PFD	18.0±0.5	15.9%

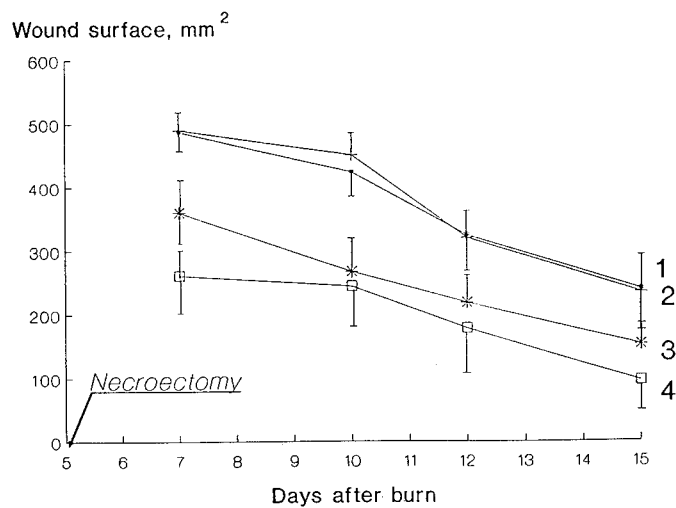

FIGURE 2. Change of the burned areas when treating with fluorogel and solkoseryl. 1 - spontaneous healing; 2 - with solkoseryl; 3 - with fluorogel under 20% O₂; 4 - with fluorogel under 76% O₂.

The results of treatment of uninfected surgical wounds with fluorogel are presented in Tables I and II.

Since the emulsion is a multicomponent preparation, the therapeutic efficacy of its main component PFD was also examined, (Table II).

The treatment of thermal burns was carried out as follows. The preparation investigated was spread onto the burned surface (2 x 2 cm) immediately after burning. The procedure was repeated every day for 3 days. Necroectomy was made on the 5-th day after burning. Further, the treatment procedure was identical to that of surgical wounds. Fig. 2 and Table III present the data showing the effect of the preparations under study on the speed of the regenerative process.

TABLE III. Treatment of burns with fluorogel and solkoseril(n=10).

Drugs	wound repair, days	accele- ration
Control, 20 % O ₂	30.3±1.0	--
Solkoseril, 20 % O ₂	29.5±0.6	2.6%
Fluorogel, 20 % O ₂	28.3±0.6	6.6%
Fluorogel, 76 % O ₂	25.3±1.1	16.5%

Note: An active oxygen aeration (76% O₂, 2-3 hours every day for 3 days) did not affect the regenerative process both in the control and solkoseril-treated groups.

DISCUSSION

The data, presented above, indicate the high efficacy of the concentrated fluorocarbon emulsion in the treatment of surgical wounds and thermal burns. The effect depends on the oxygen concentration and seems to be related particularly to the PFCs rather than to the other components of the emulsion. Nonetheless, a positive influence of some emulsion properties other than gas transport capacity should not be neglected.

The mechanism of the effect of fluorogel on the regenerative process remains unclear in many respects. It should be taken into account that the evaporation rate of PFCs from the spread emulsion is rather high, approximately 1-2 mg of PFCs/min per 1 cm² at 33°C. An interaction of the emulsion particles with specialized cells, providing reparation of skin, as well as the dissolution of fluorocarbons in the hydrophobic region of biological membranes [6] might also underlay the mechanism involved, in addition to oxygen transport of PFCs. It should be particularly emphasized that the unique physico-chemical properties of fluorocarbons are different from those of usual hydrocarbon compounds. Hence, the mechanism of the curative effect of fluorogel might differ fundamentally from that of traditional drugs. There is a hope that fluorocarbon emulsions in combination with traditional cosmetic and dermatological preparations would intensify the therapeutic effect of the latter and allow the development of new effective drugs.

REFERENCES

1. G. Pantini, F. Brunetta, J.C. Dederen, G. Bognolo. S.O.F.W., 116, No 14, 503-504 (1990).
2. G. Pantini, L. Mozetti. Technol.Chem., 8, No 3, 126-133 (1988).
3. J.G. Riess. Vox. Sang., 61, 225-239 (1991).

4. N.S. Faithfull. Oxygen Delivery from Fluorocarbon Emulsions - Aspects of Convective and Diffusive Transport. In: Blood Substitutes and Oxygen Carriers, Chang T.M.S.(ed), M. Dekker, N.Y., 569-576 (1993).
5. U. Gross, N. Groth, T. Herrling. J. Fluorine Chem., 58, 196 (1992).
6. V.V. Obraztsov, D.G. Shekhtman, A.N. Sklifas, K.N. Makarov. Biokhimiya, 53, 613-619 (1988).

EFFECT OF LIPID ABSORPTION BY PERFLUORO-CHEMICAL EMULSIONS IN THE
BLOODSTREAM AND PERSPECTIVES OF ITS CLINICAL APPLICATION.

E.V.Tereshina and N.I.Afonin
Department of Medical Biotechnology
Research Institute of Experimental and Clinical Immunology
Moscow, Russia

Studies concerning lipid absorption by perfluorochemical particles (PFC) during circulation in the blood stream have been reported in experimental animals. We studied the cholesterol absorption from high density lipoproteins (rats) and erythrocyte membrane [1] and composition of the absorbed lipids [2].

The aim of present investigation is to clarify the influence of the PFC chemical structure and synthetic emulsifier on the composition of the absorbed lipids. The perspectives of clinical application of the effect of the lipid absorption by PFC particles is discussed.

INTRODUCTION

The particle of perfluorochemical (PFC) emulsion represents a globule comprised of hydrophobic nucleus (perfluorochemicals) surrounded by a layer of amphiphilic compound (synthetic and/or natural surfactant). We have found already that during circulation in the bloodstream PFC particles absorb lipids [2]. Being amphiphilic, lipids can be accepted by the PFC particle so that fatty acids of these lipids would be plunged into the nucleus, while polar "heads" are exposed outside. The PFC-lipids interaction may be indifferent to the chemical structure of the bound lipids, or there exists a selection of lipids from the pool of lipids circulating in the blood. The specificity of the selection would be defined by the nature of the PFC and the emulsifier. In the present investigation we attempted to evaluate the influence of the PFC nature and the emulsifier presence on the composition of the absorbed lipids.

MATERIALS AND METHODS

in vivo Wistar female rats weighing 180 g were used. They were infused with 2.5 ml of PFC emulsion per 100g of weight.

Emulsions of perfluorodecalin (PFD), perfluorotripropylamine (PFTPA), PFD/PFTPA (7:3), paramethylcyclohexylpiperidine (PMCGP) all stabilised by procsanol 268 (analog of pluronic F-68) have been chosen as emulsions of perfluorochemicals of various classes and their mixtures. After 6 hours, whole blood was taken and centrifuged at 5000 x g, 10 min. The lipids were extracted from the emulsion as described [2] and analysed. Fatty acids were analysed by means of gas chromatography.

in vitro The blood of one donor was used. Plasma was mixed with the emulsion of PFD/PFTPA stabilised by procsanol 268 (emulsion 1) and the same PFCs stabilised by procsanol and yolk phospholipids (YPL) (emulsion 2). The mixture was gently shaken at 37°C during 6 hours. The fatty acid composition of the absorbed lipids was examined.

RESULTS

The analyses of the absorbed lipids have revealed the fact that during circulation in the blood stream PFC particles absorb phosphatidylcholine (PC), phosphatidylethanolamine (PE), sphingomyelin (SM), phosphatidylserine (PS), cholesterol (Chol), cholesterol esters (CholE), triglycerides (TG), free fatty acids (FFA).

In spite of the changes in the quantitative composition occurring in the course of the circulation, the PC content of the absorbed lipids remains practically unchanged while the Chol quantity is permanently increasing. The PC/Chol ratio comprising 3.5:1 after 1 h of circulation changed to 1:1 after 24 h.

Contrary to the PFD, PFTPA and PFD/PFTPA emulsions PMCGP emulsion absorbs mainly PC and SM. The PC/Chol ratio was constant and showed 1:1 during the whole period of circulation (1-24 h) (data not shown). The analyses of the neutral lipids composition of this emulsion unexpectedly revealed high content of the Chol E.

In order to define more accurately the difference of lipids absorbed by various PFCs we examined their fatty acid composition (table II).

It is seen that fatty acid composition of lipids absorbed by PFD and PFD/PFTPA emulsions are somewhat alike except for the content of separate acids such as C 18:0 (phospholipids) and C 18:0, C 18:2 (neutral lipids). The fatty acid composition of lipids absorbed by PMCGP emulsion was quite different. In this case lipids with fatty acids of high molecular weight predominated.

In order to clarify the role of the synthetic emulsifier in the specificity of the lipid absorption we tried to identify those fatty acids that were accepted by procsanol. The lipids were extracted from the emulsion PFD/PFTPA (prepared de novo) stabilised by procsanol 268 and YPL. YPL and procsanol 268 were transferred to the chlorophorm phase and analysed by thin layer chromatography (TLC) (table III). It is of interest to note that a fatty acid of high molecular weight identified as C₂₄:0 was found both in the PFD emulsion (phospholipids) and in the procsanol.

TABLE I. The composition of lipids absorbed by PFC emulsions

LIPIDS	PFD/PFTPA	PFD	PFTPA	PMCGP
*PC	52.5	54.8	48.2	36.2
*PE	10.5	6.2	9.2	16.0
*PS	10.9	13.4	10.6	14.2
*SM	26.4	25.2	39.0	33.7
total PhL+	56.2	52.9	29.9	20.0
Chol+	21.6	42.4	65.3	26.3
FFA+	5.7	4.7	4.8	13.6
TG+	8.0	trace	trace	11.6
CholE+	6.6	trace	trace	29.8

* - % of total phospholipids

+ - % of total lipids

TABLE II. The fatty acid composition of lipids absorbed by the PFC emulsions

FATTY ACIDS	EMULSIONS					
	PFD		PFD/PFTPA		PMCGP	
	LIPIDS					
	PC	NL	PL	NL	PL	NL
C 12:0	6.4	0.9	1.0	0.8	0.1	0.4
C 14:0	5.8	7.0	16.2	1.8	0.1	0.3
C 16:0	34.6	18.4	34.8	17.9	7.3	17.8
C 16:1	10.8	5.0	-	5.3	-	-
C 18:0	3.0	3.0	14.3	11.4	7.0	11.7
C 18:1	32.8	10.9	24.6	9.8	11.6	15.0
C 18:2	3.2	2.4	1.2	10.1	13.5	8.5
C 20:0	-	-	-	6.4	13.2	8.6
C 20:2	-	5.0	-	5.4	-	4.7
C 20:5	-	-	-	3.2	15.6	8.8
C 22:1	-	-	-	7.4	11.8	4.6
C 22:5	-	-	-	-	10.8	8.4
C 24:0	-	44.7	-	-	-	2.5

TABLE III. The fatty acid composition of the YPL alone, lipids of the PFD/PFTPA emulsion (prepared de novo) and TLC procsanol 268 fraction

FATTY ACIDS	YPL	PFD/PFTPA EMULSION LIPIDS	TLC PROCSANOL FRACTION
C 14:0	0.4	0.4	1.6
C 15:0	0.4	0.3	0.4
C 16:0	17.7	39.4	18.4
C 16:1	3.6	3.7	1.8
C 17:0	0.5	1.1	0.3
C 18:0	2.8	7.4	9.1
C 18:1	38.6	32.4	11.2
C 18:2	21.8	13.4	1.2
C 18:3	0.1	-	-
C 20:2	0.3	-	-
C 20:3	0.6	-	-
C 20:4	7.5	1.5	7.5
C 24:0	0.4	-	47.2
C 22:4	1.7	-	-
C 22:5	0.2	-	-
C 22:6	3.0	-	0.4

The specificity of the lipid absorption by the PFC emulsion can be demonstrated according to the results obtained during in vitro incubation with donor plasma of the emulsions stabilised by two types of emulcifier (emulsion 1 and 2) (table IV). It is shown that in the case of the emulsion 1 the fatty acid composition of the absorbed lipids didn't depend on the extent of the dilution, meanwhile in the case of the emulsion 2 the fatty acid set resembled the same as YPL at dilutions 1:1 and 1:2 and the same for emulsion 1 at dilutions of 1:4 and 1:8.

DISCUSSION

The PFCs are known as chemically inert compounds inaccessible for enzymes. Nevertheless, when circulating in the bloodstream they demonstrate biological activity. One may propose that being in plasma PFC particle resembles a chylomicron for it has similar hydrophobic nucleus (PFC) surrounded by amphiphilic compound (surface active agent and/or phospholipids).

It has been shown [1] that in the process of circulation PFC particles interact with cholesterol rich lipoproteins (such as high density lipoproteins of rats) and the erythrocyte membrane absorbing cholesterol. Investigations have revealed the PFC particle's capacity to absorb all classes of lipids: phospholipids

TABLE IV. The fatty acid composition of the lipids absorbed by the emulsions 1 and 2 after the incubation with the donor plasma

FATTY ACIDS	EMULSION 1			EMULSION 2			
	DILUTIONS						
	1:2	1:4	1:8	1:1	1:2	1:4	1:8
C 14:0	0.5	0.1	0.1	0.1	4.0	3.0	3.1
C 15:0	6.0	7.0	7.0	0.3	6.0	7.0	6.9
C 16:0	34.9	34.1	34.2	28.1	34.5	34.4	34.4
C 16:1	1.0	1.6	1.4	2.1	0.9	2.1	2.5
C 18:0	11.0	8.9	15.5	14.5	17.7	3.8	12.6
C 18:1	2.1	1.4	-	25.3	15.3	2.6	2.3
C 18:2	2.0	1.5	-	13.5	-	-	-
C 20:0	3.2	3.2	-	2.8	1.4	6.2	6.4
C 20:4	1.5	1.8	1.3	0.3	3.2	1.4	-
C 22:5	1.8	2.0	-	0.4	2.8	-	-
C 24:0	24.1	22.3	21.5	3.2	8.5	23.7	18.8
unident.	3.9	4.3	5.6	-	-	9.5	5.6

* Dilution 1:1 (emulsion 1): The analysis is impossible because of the large amount of the procsanol 268.

and neutral lipids in combinations occurred in plasma (the distribution of major and minor components) [2].

The present data is a step forward. We have found that the quantitative and qualitative composition of the absorbed lipids depended on the chemical structure of the PFC. Moreover, it was not stable and underwent certain changes during the observed period of circulation (1-24 h). The difference between the emulsions in the lipids absorbed was demonstrated by the PH/Chol ratio that changed from 3.5:1 to 1:1 (PFD/PFTPA) or remained stable 1:1 (PMCGP). According to the analyses of fatty acid distribution of the absorbed lipids, PFD/PFTPA, PFD and PFTPA emulsions differed mainly by the quantities of some acids (C 18:0, C 18:1, except for C 24:0 in PFD emulsion) while the PMCGP emulsion absorbed lipids with fatty acids of high molecular weight. We may suspect that procsanol participate in the absorbance of the fatty acid identified as C 24:0.

Do YPL prevent PFC particle from the lipid absorption? The in vitro experiments with the emulsions 1 and 2 indicate indirectly the fact that PFC particles absorbed lipids specifically from any pool whether it was YPL or plasma lipids.

The PFC particle's ability to absorb lipids and Chol of the cholesterol rich lipoproteins and cell membranes may find its application in some cases of hypercholesterinemia and

dislipoproteinemia. In our opinion the PFC emulsion's circulation in the bloodstream acts as a new additional lipid/transporting system. By manipulating with various PFCs and their combinations with emulsifiers, some novel preparations could be designed for corrections of failures in lipid metabolism.

The last decade has been devoted to searching for an effective antiAIDS remedy. HIV-1 possesses a lipid cover derived from the cell membrane. The first stage of the infection is a recognition of the viral cover glycoprotein gp120 by the host cell membrane receptor. Fluidization of both viral cover and cell membrane by Chol extraction leads to a lack of infectivity. M.Shinitzky et al., (Israel) [6] have carried out successful clinical trials of the new fluidisator AL-721 (active lipid, chylomicron-like structure) able to absorb Chol. In our in vitro experiments we evaluated the PFC emulsion effectiveness to prevent HIV-1 interaction with t_4 lymphocytes, which was more than 80% (data not shown).

In comparison with AL-721, PFC emulsions have prolonged circulation time in the bloodstream and absorb Chol to a high extent.

In conclusion, we would like to discuss briefly the phenomenon of complement activation by the PFC infusion. There are findings in the literature some findings indicating immunogenicity of phospholipids [3]. The last were able to produce specific antibodies being attached to a solid base [4]. Liposomes of certain lipid composition could activate complement [5]. Probably, the lipid absorption by PFC particles is a reason for postinfusion complications.

REFERENCES

- 1.E.V.Tereshina, N.N.Doronina, N.I.Afonin, I.N.Ozerova, I.A.Tcherbakova. Some aspects of perfluorochemical emulsion interaction with blood; *Biomat. Art Cells and Immob.Biotechnol.*, v.20, n.2-4, (1992).
- 2.E.V.Tereshina, N.N.Doronina. The composition of lipids absorbed by some perfluorochemical emulsions; *Khim.Pharm.Zhurn.*, n.7, p.16-18, (1990).
- 3.B.G.Schuster, M.Neidig, B.M.Alving, C.R.Alving. *J. Immunol.*, v.123, p.900-905, (1979)
- 4.C.B.Colaco, D.K.Male. *Clin. and Exper. Immunol.*, v.59, p.449-456, (1985)
- 5.T.Takashi, K.Inoue, S.Nojima. *J. Biochem.*, v.87, p.679-685, (1980)
- 6.A.Klajman. Treatment of AIDS with AL-721; *Isr. J. Med. Sci.*, v.26, p.2-4, (1990).

**CENTRAL HEMODYNAMICS AND BLOOD FLOW DISTRIBUTION
DURING INFUSION OF PERFLUBRON EMULSION OR ITS VEHICLE:**

Effects in anesthetized dogs

G.P. Biro, M.D., Ph.D.

Dept. of Physiology, Faculty of Medicine, University of Ottawa

Ottawa, Canada. K1H 8M5

ABSTRACT

Mongrel dogs were anesthetized and prepared for hemodynamic monitoring and the measurement of blood flow distribution using radionuclide-labelled microspheres ($15 \pm 2 \mu\text{m}$). Four dogs were infused with a perflubron emulsion (E) (90% w/v perflubron containing egg yolk phospholipid as a stabilizer) and five dogs were infused with the vehicle (V) (same composition without the perfluorocarbon). Both infusions were given at the dose of 3 ml/Kg over a 30-minute period. Measurements of blood pressures and cardiac output were made before, at 12 minutes of the infusion and at 5, 30 and 60 minutes post-infusion. Blood flow distribution was determined before, at the 15th minute of the infusion and at 2 and 60 minutes post-infusion. One dog infused with V exhibited a hypotensive reaction and urticaria; this was excluded from the group statistics. Neither group showed statistically significant hemodynamic changes during or after the infusion, although both E and V groups showed transient elevation of the stroke volume. Blood flows were raised consistently to the heart and renal cortex and transiently to some skeletal muscles by E treatment.

INTRODUCTION

While the hemodynamic effects of the first generation of perfluorocarbon (PFC) emulsions (e.g. Fluosol-DA) are well characterized [1,2], the effects of the second generation of such products, containing a higher concentration of PFC and emulsified with a different stabilizer, are not clearly defined. The present experiments were undertaken to characterize the hemodynamic effects associated with infusions of a new product (OXYGENT[®]) prepared as a 90% w/v emulsion of

perflubron (perfluorooctyl bromide) emulsified with egg yolk phospholipid [3]. The dose was chosen as that which is contemplated for clinical use in blood pool imaging of the same product (IMAGENT®). Dogs were chosen for these experiments, because of their extensive use in preclinical studies and the relative absence of pulmonary macrophages in this species; in this respect, the dog is more similar than swine to man.

METHODS

Perflubron emulsion (90% w/v AF0104 Batch # BC11090), and Vehicle (a dispersion of the same ingredients without the perfluorocarbon) (0/7.5) (Batch # ZY11024) were obtained from Alliance Pharmaceutical Corp. (San Diego, CA) and stored at 4°C until used. Prior to infusion, the vial(s) to be used was (were) brought to room temperature and administered at 25°C.

Mongrel dogs were used from a commercial source. The experimental procedure was approved by the institutional Animal Care Committee; in all respect, the animals were treated according to The Guide to the Care and Use of Experimental Animals vols. I and II (Canadian Council on Animal Care, Ottawa, Ont.).

The dogs were anesthetized by an intravenous injection of barbiturate (Somnotol 24 mg/Kg), were intubated and ventilated to maintain arterial blood pO₂, pCO₂ and pH within physiological limits. Stable anesthesia was maintained using 0.7-1.0% Penthrane in 50% O₂ : 50% N₂O. A femoral artery and femoral vein and both external jugular veins were catheterized. The right jugular vein was used to insert a Swan Ganz catheter and the left one was used for hydration and drug injections as required. The femoral artery was used for the direct recording of the arterial blood pressure and withdrawal of the arterial blood samples for microsphere-determined blood flow estimations. The left chest (fourth intercostal space) and the pericardium were opened. A catheter was inserted in the left atrium through one of the small pulmonary veins, for direct pressure measurements and the injection of microspheres. Blood pressure readings through the Swan Ganz catheter were made periodically. Cardiac output was determined in triplicate by the injection of 5 ml of ice-cold 5% glucose-in-water

solution, by the thermodilution method. Blood temperature in the pulmonary artery was continuously monitored using the Swan Ganz thermistor. Lead II ECG was continuously recorded.

When the experimental preparation was completed, a 15-minute rest period was allowed to attain a stable cardiovascular state. E or V was infused intravenously in a dose of 3 ml/Kg over a 30-minute period. Pressures and cardiac output were determined in the pre-infusion control stage, at the mid-point and at the end of the 30-minute infusion and 30 and 60 minutes post-infusion. Microspheres were injected before, at the mid-point and end of the infusion, and 60 minutes after its completion. The experiment was terminated at 95 minutes by the intravenous injection of KCl-Euthanyl mixture. Triplicate tissue samples were taken from each chamber of the heart, from the lung, liver, spleen, pancreas, segments of the gastrointestinal tract, the thyroid and adrenal glands, brain and spinal cord and muscle and skin from various sites. The samples were weighed and the radioactivity attributable to each nuclide was determined, at appropriate window settings, on an LKB Compu-Gamma gamma spectrometer. Automatic corrections were made for spillover and for decay due to elapsed time. From the tissue specific activity, blood flow was determined by the method of Bartrum et al. [4].

RESULTS

Four dogs were infused with perflubron emulsion and five dogs were infused with the vehicle. No reactions occurred in the four dogs receiving the perflubron emulsion. One of the five dogs receiving vehicle exhibited a reaction characterized by progressive decline of the blood pressure, and after the end of the infusion gross urticaria was present. This experiment was excluded from the summary data. Repeated measures ANOVA and Student's t-test were used to assess statistical significance, recognizing that both tests applied to small samples have limited validity.

In hemodynamic terms (Fig. 1), while the heart rate remained constant, stroke volume rose in both emulsion- and vehicle-infused dogs. The systemic arterial blood pressure tended to decline in the former group (from 150 ± 8 to

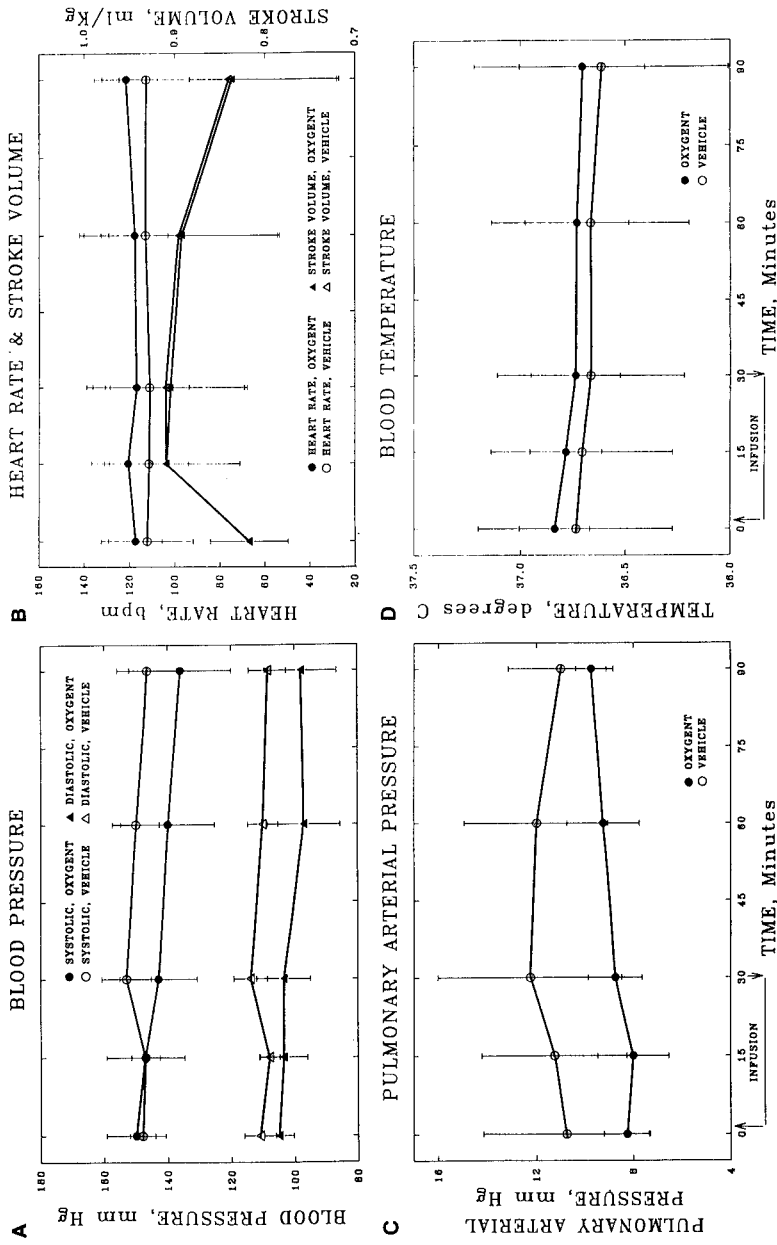

FIGURE 1: Graphic summary of the hemodynamic variables measured in the group of dogs infused with perflubron emulsion (OXYGEN[®]; closed symbols) and with vehicle (open symbols).

136±14 mmHg systolic), whereas it remained essentially constant in the vehicle-infused group. Pulmonary arterial mean pressure rose from 8.3±0.8, to 9.8±0.5 mmHg in the perflubron treated dogs and from 10.8±1.5 to 11.0±0.9 mmHg in the vehicle-infused group; two dogs in the former and one in the latter group showed an increase exceeding 2 mmHg. None of these changes were of a statistically significant magnitude. The right and left heart filling pressures remained constant. Blood temperature remained constant.

In our hands, the reproducibility of microsphere-determined blood flow is ± 12%; thus, changes in magnitude smaller than this value are not considered *physiologically* significant.

Perflubron emulsion induced significant blood flow elevations in the left and right ventricle (Fig. 2), while in the vehicle-infused dogs myocardial blood flow remained essentially stable. Bronchial arterial blood flow remained constant in both groups. No statistically significant blood flow change was noted in either group in the stomach, duodenum, small or large intestine (Fig. 3), or in the thyroid and adrenal glands (not shown). Blood flow to the renal cortex (Fig. 4), although numerically elevated in both groups, was elevated to a statistically significant extent in the E-treated group only because of greater variability in the control period in the V-treated dogs. Renal medullary blood flow remained essentially stable (Fig. 4). Hepatic arterial blood flow (Fig. 3) was transiently (at 15 minutes of the infusion) but not significantly reduced in the perflubron-treated group and returned to the "normal" range after the infusion; in the vehicle-infused group, no change was observed. Splenic blood flow (Fig. 3) tended to increase in both groups with time, while pancreatic blood flow remained essentially constant; neither of these changes reached a statistically significant magnitude. Samples taken from a variety of muscles showed essentially unchanged flow with a very modest trend to increase in both groups. Skin samples showed a wide variability and no consistent or significant change in either group. Brain and spinal cord showed no significant change in blood flow in either group.

In the one dog exhibiting a reaction, the skin samples alone showed a several-fold rise in blood flow, apparently peaking at 30 minutes of the infusion.

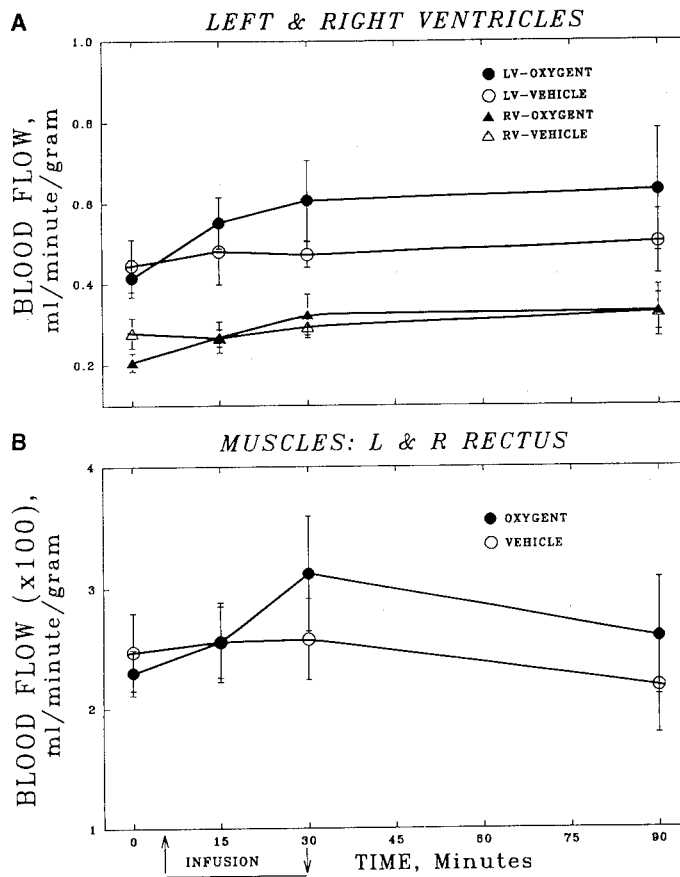

FIGURE 2: Graphic summary of the blood flow measurements in the heart (top panel) and in skeletal muscle (bottom panel) in the two groups of dogs.

DISCUSSION

This study used a small sample size and its conclusions must be viewed in this light. The two groups showed a remarkable absence of dramatic and significant hemodynamic and blood flow changes following infusion of perflubron emulsion or its vehicle. Qualitative differences in the responses between the two groups were relatively minor. Augmented myocardial blood flow has been

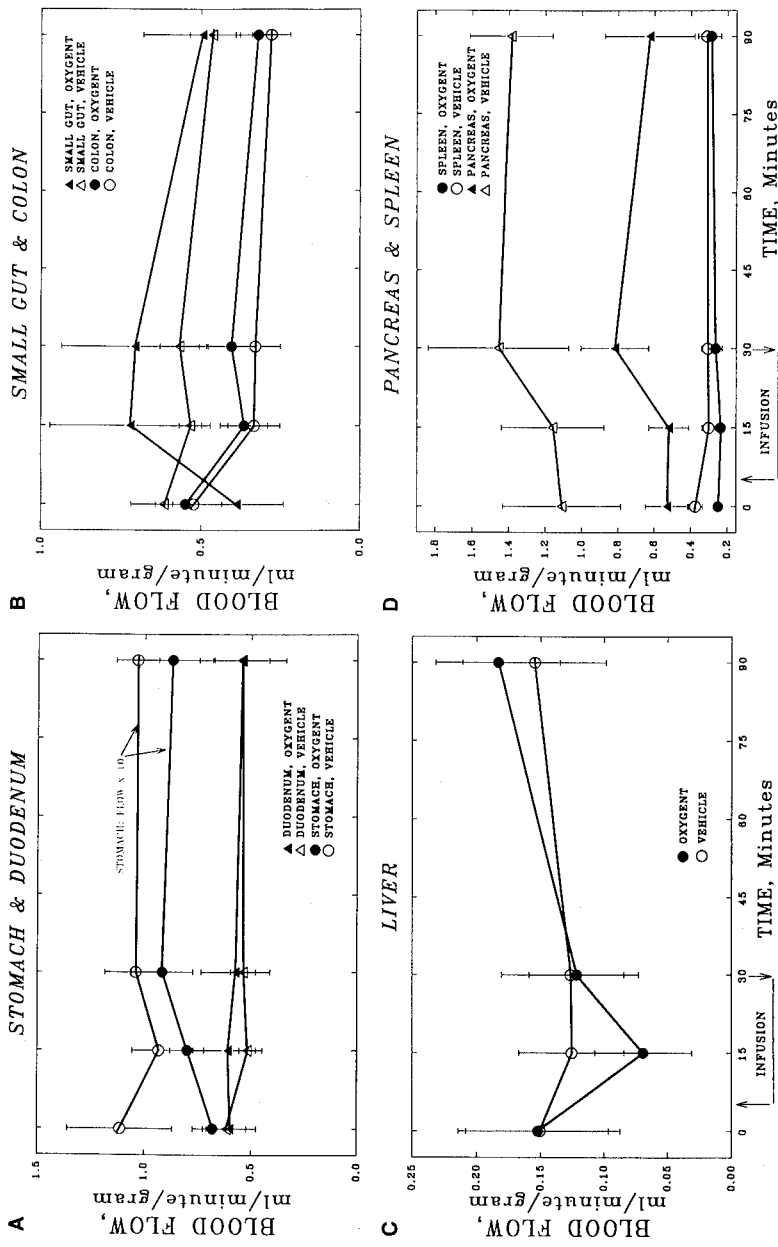

FIGURE 3: Graphic summary of the blood flow measurements made in various abdominal organs in the two groups of dogs.

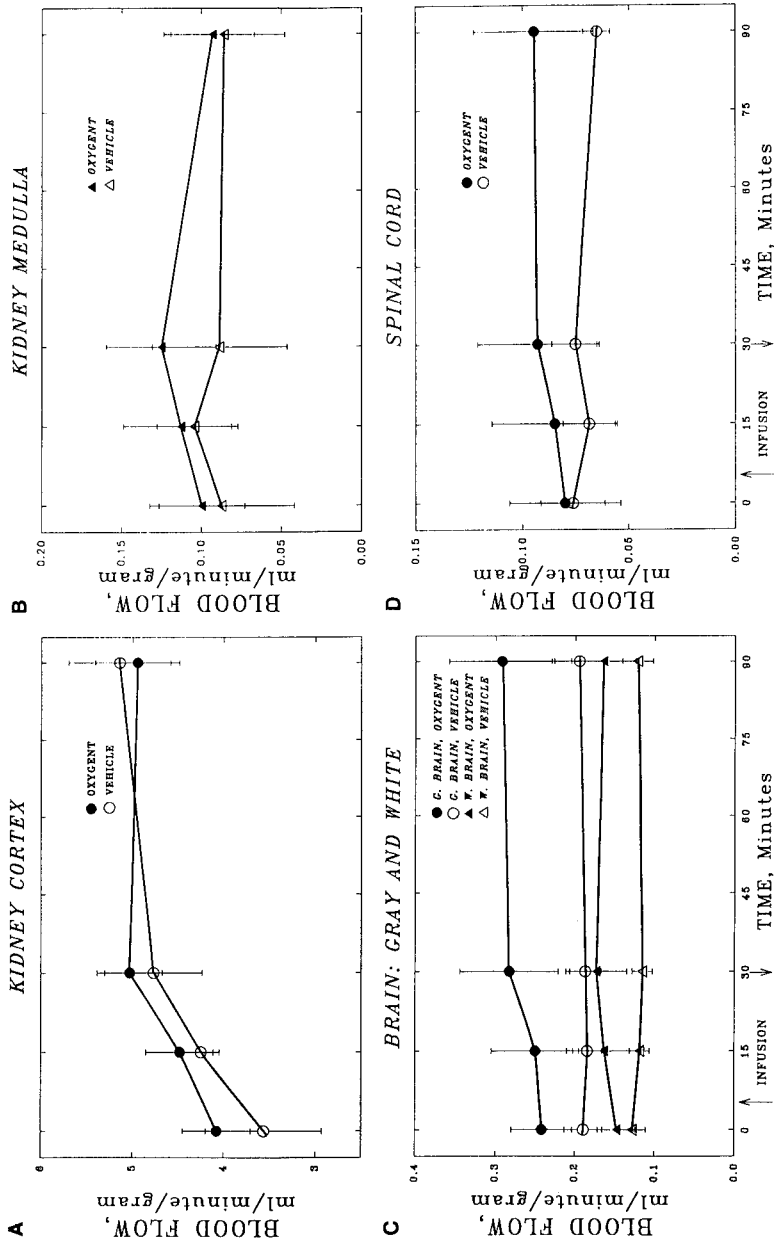

FIGURE 4: Graphic summary of the blood flow measurements made in kidney (top panels) and in nervous system (bottom panels) in the two groups of dogs.

repeatedly observed during and after the infusion of various fluorocarbon preparations [2]. The other organs failed to show a quantitatively similar degree of flow- and resistance-change and, for this reason, it is difficult to ascribe this change to rheological (i.e. physical) factors. This conclusion is also supported by the fact that the changes were numerically greater in the perflubron-treated than in the vehicle-treated groups, even though the two groups had similar declines in hematocrit and, presumably, in hemorheological properties. On the other hand, closely comparable changes in stroke volume, exhibiting a similar time course, suggest the operation of a hemorheological explanation of altered impedance to ejection. The significance of the modest increments in renal cortical blood flow, in magnitude comparable between the two groups, is unclear at this time; it may also have a hemorheological basis. It is, also, noteworthy that the presence of perflubron enhanced ultrasonographic images in the kidney [5,6], possibly by virtue of its concentration in blood within the renal circulation.

As noted above, the only other change appeared to be the transient fall in hepatic arterial flow. One of the possible concerns expressed in relation to the use of PFC's was the fact that the uptake of PFC particles into the reticuloendothelial system cells might distort the normal architecture and thereby impair blood flow in the hepatic sinusoids. The fact that only a transient (and statistically not significant) flow change was observed, with normal flow being restored rapidly, suggests that in the short time-frame of this experiment, this concern was not substantiated. It must be noted, however, that the uptake of PFC during the very short period of observation in this experiment would only be minimal. A much longer period of observation, supplemented by morphological examination and the quantitative estimation of hepatic tissue PFC-content, is required to assess fully the validity of the above concern. The significantly shorter *in vivo* half-life of perflubron (4 days) than that of the constituents of Fluosol-DA (7 and 65 days) would indicate that whatever physical effects may be exerted upon hepatic hemodynamics, they would likely be short-lived.

The present study used a dose that is significantly smaller than that given in numerous previous experiments using large volumes of Fluosol-DA wherein the effects following a partial exchange transfusion were assessed [2]. The latter

demonstrated more and larger changes in blood flow distribution, resulting from a larger dose, far greater hemodilution and presumably greater hemorheological change. Hence, comparisons are not appropriate. Previous studies using a similar (though not identically prepared) emulsion administered to dogs [7] showed only minor hemodynamic effects manifested by a modest blood pressure-fall. In pigs, the effects were somewhat more pronounced [8].

The one reaction observed does not permit any conclusions regarding mechanisms or the likelihood that it was related to vehicle-vs-active ingredient differences. While reactions do occur to microspheres, the rapid and usually reversible hypotensive episodes tend to be numerically more frequent than the progressive hemoconcentration, urticaria and irreversible hypotension observed in this experiment [9]. Both dextran and Tween are present in microsphere suspensions and have been implicated in reactions [9,10]; while the reactions are more frequently documented in rats, they also occur in dogs [8]. The reaction was similar to that observed in dogs infused with homologous plasma and is clearly of an "allergic" nature, but its progressive nature precludes the identification of its causative agent.

In conclusion, these experiments have demonstrated that infusions of a 90% w/v perflubron emulsion, in a dose of 3 ml/Kg over a 30-minute period, has only mild hemodynamic effects characterized by a very modest drop in blood pressure (<10%), and increases in myocardial and in renal cortical blood flows. Apart from these positive findings, we found no other significant changes.

ACKNOWLEDGEMENTS

Financial support for these experiments and perflubron emulsion and vehicle were provided by Alliance Pharmaceutical Corp., San Diego, CA 92121. The technical assistance of M. Bosc-Davie, P. Bradley, D. Mauldin and J. Sisteck and the excellent secretarial assistance of D. Blais and D. Mulder is gratefully acknowledged.

REFERENCES

1. G.P. Biro, P. Blais. Perfluorocarbon blood substitutes. *C.R.C. Crit. Rev. Oncol/Hematol.* **6**:311-374 (1987).

2. G.P. Biro. Perfluorocarbon-based red cell-substitutes. (In Press) *Transf. Med. Rev.* April (1993).
3. J.G. Riess, J.L. Dalfors, G.K. Hanna, D.H. Klein, M-P. Krafft, T.J. Pelura, E.G. Schutt. Development of highly fluid, concentrated and stable fluorocarbon emulsions for diagnosis and therapy. *Biomat., Art. Cells and Immob. Biotech.* 20:839-842 (1992).
4. R.J. Bartrum Jr., D.M. Berkowitz, N.K. Hollenberg. A simple radioactive microsphere method for measuring regional blood flow and cardiac output. *Invest. Radiol.* 9:126-132 (1974).
5. R.F. Mattrey. Perfluorooctylbromide: a new contrast agent for CT, sonography and MR imaging. *Amer. J. Radiol.* 152:247-252 (1989).
6. B.D. Coley, R.F. Mattrey, R.M. Mitten et al. The physiologic basis of the radiodense renal medulla after the administration of blood pool contrast agent PFOB. *Invest. Radiol.* 25:1287-1293 (1990).
7. R.F. Mattrey, P.L. Hilpert, C.D. Long et al. Hemodynamic effects of intravenous lecithin-based perfluorocarbon emulsions in dogs. *Crit. Care Med.* 17:652-656 (1989).
8. W.W. Peck, R.F. Mattrey, R.A. Slutsky et al. Perfluorooctyl bromide: acute hemodynamic effects, in pigs, of intravenous administration compared with the standard ionic contrast media. *Invest. Radiol.* 19:129-132 (1984).
9. R.F. Millard, H. Baig, S.F. Vatner. Cardiovascular effects of radioactive microsphere suspensions and Tween 80 solutions. *Amer. J. Physiol.* 232:H331-H334 (1977).
10. S.F. Flaim, Z.Q. Morris, T.J. Kennedy. Dextran as a radioactive microsphere suspending agent: severe hypotensive effect in rat. *Amer. J. Physiol.* 235:H587-H591 (1978).

**TUMOR OXYGENATION AFTER 1) CARBOGEN AND/OR
PERFLUBRON EMULSION ADMINISTRATION IN TUMOR
XENOGRAFTS 2) CARBOGEN ADMINISTRATION IN PATIENTS.**

M. Guichard*, E. Lartigau*, L. Martin*, C. Thomas*, P. Weeger**, P. Lambin*,
A.M. Le Ridant**, A. Lusinchi***, P. Wibault***, B. Luboinski**,
F. Eschwege***

*Laboratoire de Radiobiologie Cellulaire (Unité Inserm 247)

** Département de Chirurgie Cervico-Faciale

*** Département de Radiothérapie

Institut Gustave-Roussy

94804 Villejuif cedex, France.

This study examines the changes in tumor pO₂ distribution assessed by polarography (KIMOC 6650, Eppendorf) in 1) two human tumor xenografts after carbogen inhalation with or without a perflubron (perfluorooctylbromide) emulsion (Oxygent™, Alliance Pharmaceutical corp.) and in 2) human head and neck carcinomas after carbogen inhalation. Mice bearing HRT18 or NA11+ tumors were restrained and their body temperature was kept constant. Perflubron emulsion (4 ml/kg) was injected i.v. in the mice. In patients, oxygenation of the head and neck metastatic lymph nodes was assessed before and/or during carbogen exposure. The distribution of pO₂ values shifted upwards during carbogen exposure in both animals and patients while the proportion of low pO₂ values decreased. The maximal effect was obtained with patients after 1 to 6 minutes of carbogen exposure, but 4 patients still maintained very low pO₂s. Carbogen plus 4 ml/kg perflubron emulsion was more efficient than carbogen alone for increasing hypoxic tumor pO₂ in animals. If the animals data could be extrapolated to humans, then the effect of carbogen on tumor oxygenation should be increased by perflubron emulsion administration.

INTRODUCTION

There is good evidence that hypoxia plays a major role in tumor radiosensitivity. There is no doubt that murine and xenografted tumors often contain hypoxic cells [1]. In man, direct and indirect studies show that tumor oxygenation is lower than normal tissue oxygenation, and may include very low pO_2 values (<10 mmHg) [2].

The effect of breathing carbogen (95% O_2 - 5% CO_2) upon tumor oxygenation have been widely studied in animals. Tumor radiosensitivity is enhanced, but, this enhancement depends on the pre-irradiation breathing time [3]. 90% w/v perflubron emulsion (perfluorooctyl bromide, Oxygent™, Alliance) [4-6] is one of the best candidates for further increasing tumor oxygenation in cancer radiotherapy [7,8].

New polarograph equipment (KIMOC 6650 Eppendorf, Germany) can be used to measure pO_2 in human tumors reproducibly and safely. Its use in the clinic can give the oxygenation status of the tumors in human, and also predict the likely effect of carbogen and perflubron emulsion on the tumor pO_2 distribution; of special interest is the search for disappearance of low pO_2 values.

This work first examines the changes in tumor pO_2 distribution in two human tumor xenografts after carbogen inhalation with and without a perflubron emulsion. We have also monitored the changes in pO_2 distribution in human head and neck tumors after carbogen inhalation.

MATERIALS AND METHODS

Xenografts. Two human tumor cell lines, a melanoma Na11+ and a rectal adenocarcinoma HRT18 were used; $3 \cdot 10^6$ cells were injected subcutaneously into the flank of 3-5 month old athymic mice that had been irradiated 3 to 5 days before with 5 Gy. The experiments were performed when the diameters of the tumors were 7-9 mm, 4-5 weeks (Na11+) and 7-8 weeks (HRT18) after injection of the cells.

Tumors in patients. 20 patients suffering from untreated primary squamous carcinoma of the head and neck were studied. All pO_2 measurements were performed in a metastatic lymph node. Informed consent was obtained before

measurement and this study was approved by the local committee for protection of individuals in biomedical research (CCPPRB).

Polarography. The pO_2 tension was measured using a computerized polarographic system (KIMOC 6650), as previously described [9]. Briefly, a 12 μm diameter cathode mounted in an unbreakable stainless steel needle probe (300 μm) was placed in the tumor while the Ag/Ag Cl anode was placed on the skin in the vicinity of the tumor. The probe was moved automatically through the tissue in programmed steps. The device was also used in a static position in a few patients to determine the time required for the maximal effect of carbogen breathing.

Carbogen and perflubron emulsion.

Animals. Carbogen was given for 10 minutes at a flow rate of 9 l/minute. The mice were unanesthetized and restrained. The body temperature was maintained at $35^\circ C \pm 1^\circ C$ with warm pads. The 90% w/v perflubron emulsion (4 ml/kg) was injected via the retroorbital sinus.

Patients. Patients breathed carbogen (15 l/min) via a rubber mouth - piece connected to a plastic two-way valve and they wore nose clip.

RESULTS

Animals

The carbogen and the perflubron emulsion - carbogen combination shifted the pO_2 distribution to higher values: the median was higher than in the control (Fig. 1). The shift was greater with perflubron emulsion-plus-carbogen than with carbogen alone. With carbogen, the proportion of very low hypoxic pO_2 values (2 mmHg) decreased only in HRT18 cell line. Similar results were obtained for values below 10 mmHg (Fig.1). With perflubron emulsion-plus-carbogen, no hypoxic pO_2 values below 2 mmHg were found in HRT18 and the proportion of pO_2 values below 10 mmHg decreased in both cell lines (Fig.1).

Patients

Most of the head and neck cancer patients had a higher proportion of low hypoxic tumor pO_2 readings before carbogen breathing (Table 1) with 18 out of 20 patients having pO_2 's below 10 mmHg. During carbogen breathing, most of the patients had fewer low values and the median pO_2 was increased. However, the distribution was almost unchanged in 3 patients (n° 9, 12 and 19). The pO_2

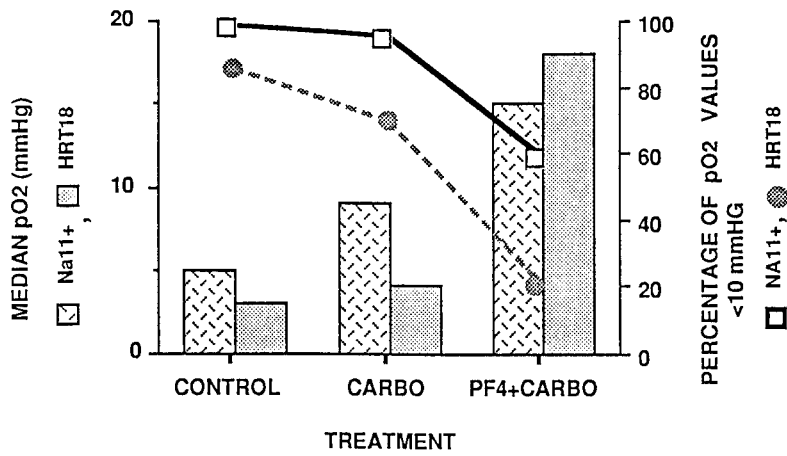

FIGURE 1. Percentage of pO₂ values below 10 mmHg (right) and median of pO₂ values (left) obtained with different treatments: control, carbogen (carbo), perflubron 4 ml + carbogen (PF4 + carbo).

TABLE I. pO₂ IN TUMOR TISSUES BEFORE CARBOGEN BREATHING (BC) AND DURING CARBOGEN BREATHING (DC)

PATIENTS	Median pO ₂ (mmHg)		Percentage of readings			
	BC	DC	< 2 mmHg		< 10 mmHg	
			BC	DC	BC	DC
1	2	165	56	0	73	0
2	3	205	2	0	80	13
3	16	126	40	0	50	0
4	13	105	0	0	8	0
5	43	157	0	0	0	0
6	7	271	7	0	67	0
7	10		0		47	
8	4		8		74	
9	9	6	0	0	80	100
10	2	76	52	3	70	7
11	17	67	33	0	39	0
12	16	17	4	7	35	32
13	6	141	21	39	65	42
14	38		3		14	
15	50		16		34	
16	30		0		0	
17	35		21		31	
18	15		2		27	
19	5	3	22	22	70	71
20	2	13	66	0	89	24

30 to 113 measurements for each value

distribution was studied before carbogen and after the end of carbogen breathing (3 to 6 minutes later) in 2 patients (n° 7 and 8); there was little increase if any in pO₂.

The time course of the effect of carbogen breathing was studied by placing the probe statically in the nodes for an adaptation phase. After equilibration, the patient began to start carbogen breathing while pO₂ was recorded continuously to determine the elapsed time of maximal effect. The time between the beginning of gas inhalation and the start of the pO₂ increase varied from 30 seconds to 3 minutes in 15 cases, in one patient the delay was 5 minutes. The maximal effect was obtained 1 - 6 minutes after the beginning of inhalation. Fifteen patients showed a plateau; in one case the pO₂ slowly decreased. The low pO₂ values were not improved by carbogen breathing in 2 patients.

CONCLUSIONS

Carbogen is often an efficient way to increase tumor oxygenation in both animal tumors and tumors in patients, however, it is not infallible. Maximal oxygenation is obtained quickly (1 to 6 minutes) in xenograft tumors, the combination of perflubron 4 ml/kg plus carbogen was more efficient than carbogen alone to increase pO₂ values resulting in less hypoxic tissues with the Na11+ cell line and none in the HRT18 cell line. Extrapolating these xenograft tumor results indicate that this combination (perflubron/carbogen) should provide increase tumor oxygenation in patients.

ACKNOWLEDGEMENTS

This work was supported in part by the Ligue Nationale Française Contre le Cancer (Comité des Hauts-de-Seine) et by the Association pour la Recherche sur le Cancer. We thank Mrs Joëlle Encinas for her secretariat assistance.

REFERENCES

1. M. Guichard, Comparison of the radiobiological properties of human tumour xenografts and rodent tumors, *Int. J. Radiat. Oncol. Biol. Phys.*, 56, 583-586 (1989).
2. P. Vaupel, Oxygenation of human tumors, *Strahlenther. Onkol.*, 166, 377-386 (1990).

3. D.W. Sieman, R.P. Hill and R.S. Bus, The importance of the pre-irradiation breathing times of oxygen and carbogen (5% CO₂; 95% O₂) on the in vivo radiation response of a murine sarcoma, *Int. J. Radiat. Oncol. Biol. Phys.*, 2, 903-911 (1977).
4. J.G. Riess, J.L. Dalfors, G.K. Hanna, D.H. Klein, M.P. Krafft, T.J. Pelura and E.G. Schutt, Development of highly concentrated and stable fluorocarbon emulsions for diagnosis and therapy. *Biomat. Art. Cells and Immob. Biotech.*, 20, 839-842 (1992).
5. J.G. Riess, Fluorocarbon-based *in vivo* oxygen transport and delivery systems. *Vox. Sang.*, 61, 225-239 (1991)
6. J.G. Riess, Overview on progress in the fluorocarbon approach to in vivo oxygen delivery. In: *Blood Substitutes and Oxygen Carriers*, Chang TMS (ed), M. Dekker, New York, 24-43 (1993).
7. C. Thomas, E. Lartigau, E.P. Malaise and M. Guichard, New high O₂ carrying perfluorochemical emulsions and/or carbogen: reactions of a human tumor xenograft to irradiation, *Int. J. Radiat. Oncol. Biol. Phys.*, 16, 1157-1160 (1989).
8. S. Rockwell, M. Kelley, C.C. Irvin, C.S. Hugues, E. Porter, H. Yabuki and J. Fischer, Modulation of tumor oxygenation and radiosensitivity by a perfluorooctylbromide emulsion, *Radiother. Oncol.*, 22, 92-98 (1991).
9. E. Lartigau, A.M. Le Ridant, P. Lambin, P. Weeger, L. Martin, R. Sigal, A. Lusinchi, B. Luboinski, F. Eschwege and M. Guichard, Oxygenation of head and neck tumors, *Cancer*, 71, 2319-2325 (1993).

**TUMOR OXYGEN TENSION: MEASUREMENT USING
OXYGENT™ AS A ¹⁹F NMR PROBE AT 4.7 T**

R. P. Mason and P. P. Antich,
Department of Radiology,
UT-Southwestern Medical Center,
Dallas, TX 75235-9058.

ABSTRACT

We have used Oxygent™ (an emulsion of perflubron [PFOB]) to measure pO₂ in a Dunning prostatic adenocarcinoma non-invasively using ¹⁹F NMR spectroscopy. We have confirmed a linear relationship between the spin-lattice relaxation rate (R₁) and pO₂ and we have assessed the effect of temperature. R₁ of the individual resonances of Oxygent is considerably more sensitive to changes in pO₂ than other PFC emulsions, whilst being considerably less sensitive to interference from temperature variation. Oxygent has two well resolved resonances ($\Delta\delta \sim 18\text{ppm}$) and these were both exploited to estimate tumor pO₂ = 47 ± 5 torr.

INTRODUCTION

There is developing interest in the use of fluorinated materials to act as physiological reporter molecules *in vivo* [1]. Perfluorocarbon emulsion blood substitutes exhibit intense ¹⁹F nuclear magnetic resonance (NMR) signals, which are sensitive to the microenvironmental milieu. Ever since it was shown that the NMR spin-lattice relaxation rates (R₁) of the ¹⁹F resonances of perfluorocarbon emulsions are sensitive to oxygen tension, there have been attempts to exploit this phenomenon to measure pO₂ *in vivo* [1]. We have

measured dynamic changes in pO_2 in the tumor and liver of live mice [2, 3] and the perfused rat heart [4] using Oxypherol (an emulsion of perfluorotributylamine) and we have previously used Oxygent in the mouse liver at high magnetic field (7 Tesla)[5]. Since most investigations of larger animals and patients are conducted at lower magnetic field, we have now investigated the application of Oxygent at 4.7 T.

MATERIALS AND METHODS

Calibrations: The relationship ($R_1 \propto pO_2$) was determined experimentally for OxygentTM (90%w/v emulsion perflubron [perfluorooctyl bromide (PFOB)], Alliance Pharmaceutical Corp., San Diego CA) using techniques described previously [2]. Standard gases (0-100% O_2 , where 100% \sim 760 torr) were bubbled through aliquots of Oxygent in order to obtain specific oxygen concentrations and the samples were placed in gas-tight NMR tubes. NMR experiments were conducted in a 4.7 T CSI spectrometer with ^{19}F at 188.3 MHz. R_1 was determined using pulse-burst saturation recovery experiments on the downfield resonances (18 and 0 ppm) and on the upfield resonances separately. We have also examined the variation of R_1 with temperature in the range 27-37 °C.

In vivo: A Dunning prostate adenocarcinoma R3327-AT1 was implanted in a pedicle on the fore-back of a Copenhagen rat [6]. When the tumor reached about 1.5 cm diameter a total of 20 ml Oxygent was infused IV into the tail of the rat over a period of 1 week. Four days after the final dose, following complete vascular clearance of Oxygent, the rat was anesthetized (2:1:: $N_2O:O_2$ + 0.5% methoxyflurane) and the tumor observed by ^{19}F NMR spectroscopy with a coil around the tumor. The rectal temperature was measured using an optical fiber probe. In addition the tumor was imaged by 1H and ^{19}F MRI to determine the distribution of PFC in the tumor.

RESULTS

The ^{19}F NMR spectrum of OxygentTM shows five well resolved signals in a tumor *in vivo* at 4.7 T (Fig. 1). A linear relationship

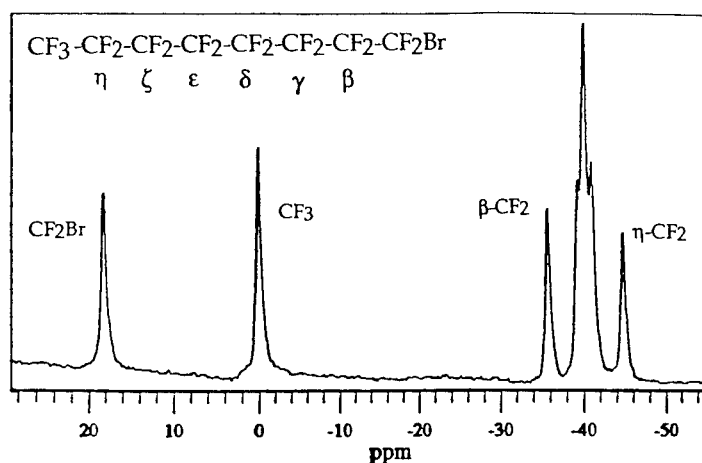

FIGURE 1 188.3 MHz ^{19}F NMR spectrum of OxygentTM in the tumor. Spectral assignments [7].

between spin lattice relaxation rate and oxygen tension (R_1 (s^{-1}) = $m\%p\text{O}_2 + c$) was determined for each signal at 37 °C (Table I and Fig. 2). R_1 is not only dependant on $p\text{O}_2$, but also temperature (Table 2 and Fig. 3).

In the AT1 tumor we measured R_1 (CF_3) = 0.40 s^{-1} and R_1 (CF_2Br) = 0.40 s^{-1} . The rectal temperature was 33 °C and thus, using the calibration curves in Table II, $p\text{O}_2$ was estimated as 6.9% and 5.5 % respectively or ~ 45 torr. ^{19}F MRI indicated that Oxygent was distributed throughout the tumor, with highest density close to the periphery.

DISCUSSION

We have demonstrated the application of OxygentTM as a probe of tumor $p\text{O}_2$ using ^{19}F NMR spectroscopy at 4.7 T. The ^{19}F NMR spectrum shows 5 well resolved signals *in vivo* and each exhibits a linear relationship between R_1 and $p\text{O}_2$. In addition, there is a linear response to changes in temperature.

TABLE I The relationship $R_1 = f(pO_2)$ at 37 °C

Emulsion	Resonance Chemical shift ppm	Intercept (c) s^{-1}	Slope (m) $s^{-1}/\%$	Sensitivity $\eta=(m/c)$
Oxygent™ (4.7 T)				
(CF ₂ Br)	18	$R_1 = 0.2893 + 1.52 \times 10^{-2}(\%pO_2)$		5.3
(CF ₃)	0	$R_1 = 0.2677 + 1.61 \times 10^{-2}(\%pO_2)$		6.0
(β)	-36	$R_1 = 0.2762 + 1.50 \times 10^{-2}(\%pO_2)$		5.4
(γ+δ+ε+η)	-40	$R_1 = 0.3840 + 1.48 \times 10^{-2}(\%pO_2)$		3.9
(ζ)	-45	$R_1 = 0.2890 + 1.54 \times 10^{-2}(\%pO_2)$		5.3
Oxygent™ (7 T)				
(CF ₃)	0	$R_1 = 0.290 + 1.73 \times 10^{-2}(\%pO_2)$		6.0 [5]
Oxypherol (4.7 T)				
(CF ₃)	0	$R_1 = 0.779 + 1.75 \times 10^{-2}(\%pO_2)$		2.2 [8]

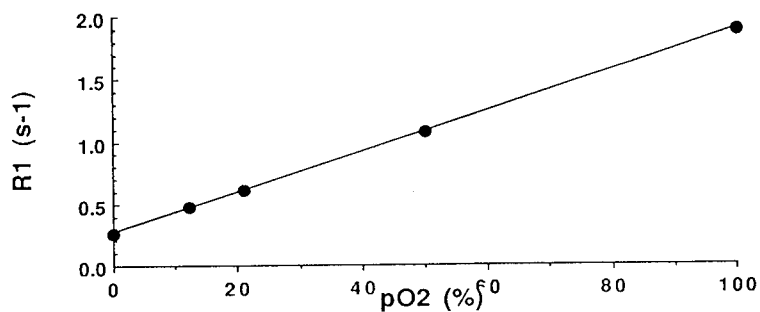

FIGURE 2 The variation of ¹⁹F NMR spin-lattice relaxation rate (R₁) with pO₂ for Oxygent at 37 °C and 4.7 T. ● CF₃ (0 ppm)

Table II The influence of temperature on the relationship $R_1 = f(pO_2)$ for Oxygen at 4.7 T

Resonance	Intercept (c) s ⁻¹	Slope (m) s ⁻¹ /%	Temperature °C
CF ₂ Br	$R_1 = 0.3374 + 1.71 \times 10^{-2}(\%pO_2)$		27
CF ₂ Br	$R_1 = 0.3152 + 1.54 \times 10^{-2}(\%pO_2)$		33
CF ₂ Br	$R_1 = 0.2893 + 1.52 \times 10^{-2}(\%pO_2)$		36.6
CF ₃	$R_1 = 0.3018 + 1.836 \times 10^{-2}(\%pO_2)$		27
CF ₃	$R_1 = 0.2772 + 1.797 \times 10^{-2}(\%pO_2)$		33
CF ₃	$R_1 = 0.2677 + 1.613 \times 10^{-2}(\%pO_2)$		36.6

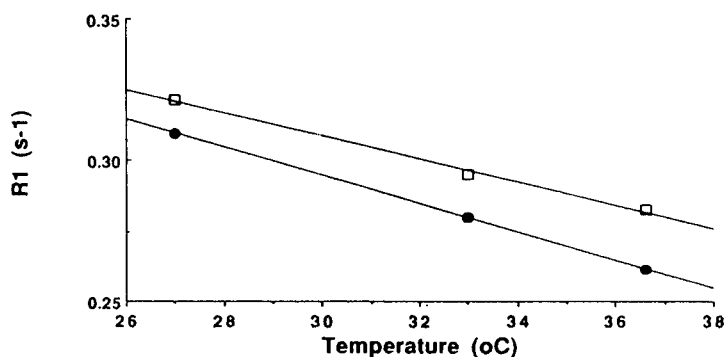

FIGURE 3 The variation of R_1 with temperature in the absence of oxygen ($pO_2=0\%$) for Oxygen at 4.7 T: ● CF₃ $R_1 = 0.444 - 4.97 \times 10^{-3}$ (°C) and □ CF₂Br $R_1 = 0.432 - 4.10 \times 10^{-3}$ (°C).

Using a sensitivity index ($\eta = \text{slope}/\text{intercept}$) [9] it is clear that the resonances at 18ppm (CF₂Br) and 0 ppm (CF₃) are the most sensitive to changes in pO_2 . It is interesting to note that there is very little difference between the calibration curves at 4.7 T and those previously reported at 7 T ([5] & Table I). However, we do note that application of the 7 T curves to the current data would produce an error ~ 15 torr, which is radiobiologically significant. The sensitivity to pO_2 of each of the Oxygen signals is considerably greater than that of most sensitive

signal of Oxypherol (Table I). At the same time Oxygent is far less sensitive to changes in temperature, so that small errors in temperature measurement produce less error in pO₂ estimation, *viz*, a 2 °C error in temperature estimation gives an error of 0.6% (5 torr) for Oxygent, whereas an error of ~ 15 torr is typical for Oxypherol [8]. The large separation of the CF₃ and CF₂Br resonances ensures the signals are resolved even at lower magnetic field and permits individual R₁ estimates to be obtained. This provides independent estimates of pO₂ enhancing the confidence in the result. The wide separation of the resonances also facilitates chemical shift selective imaging avoiding chemical shift artifacts.

In conclusion, Oxygent offers several advantages as an NMR probe of tissue oxygen tension: high sensitivity to pO₂; relative insensitivity to temperature and well resolved signals. We have now successfully used Oxygent to measure pO₂ in the liver [5], heart [7] and tumor. Given the preliminary use of perflubron in clinical trials [10] we envisage application to monitor oxygen tension in patients in the near future.

ACKNOWLEDGEMENTS

We are grateful to Alliance Pharmaceutical Corp. for support. NMR experiments were performed at the Mary Nell & Ralph B. Rogers MR Center. We are indebted to Drs. Eric Hahn and Peter Peschke (DKFZ, Heidelberg) for establishing the tumor model and to Dr. Anca Constantinescu for technical assistance.

REFERENCES

1. R.P. Mason, "Non-invasive physiology: ¹⁹F NMR of perfluorocarbons", These Proceedings, ISBS (1993)
2. R.P. Mason, R.L. Nunnally & P.P. Antich, *Magn. Reson. Med.*, 18, 71-79 (1991)
3. R.P. Mason, H. Shukla & P.P. Antich, *Magn. Reson. Med.*, 29, 296-302 (1993)

- 4 R.P. Mason, F.M.H. Jeffrey, C.R. Malloy, E.E. Babcock & P.P. Antich, *Magn. Reson. Med.*, 27, 310-317 (1992)
- 5 R.P. Mason, H. Shukla & P.P. Antich, *Biomat. Artif. Cells Immob. Biotech.*, 20, 929-932 (1992)
- 6 E. W. Hahn, P. Peschke, R. P. Mason, E. E. Babcock, & P .P. Antich, manuscript submitted (1993)
- 7 H. Shukla, R.P. Mason & P.P. Antich, in preparation (1993)
- 8 R.P. Mason, P. P. Antich, E.E. Babcock, A. Constantinescu, P. Peschke & E.W. Hahn, submitted (1993)
- 9 S.R. Thomas, R. Millard, K. Tan, R.G. Pratt, L.J. Busse & R.C. Samaratunga, *Proc. Soc. Magn. Reson. Med.*, San Francisco, 342 (1988)
- 10 R.F. Mattrey & D.C. Long, *Invest. Radiol.*, 23, s298-301 (1988)

**OXYGENATION OF HUMAN TUMOR XENOGRAFTS IN NUDE
MICE BY A PERFLUORO-CHEMICAL EMULSION AND
CARBOGEN BREATHING**

B. A. Teicher, G. N. Schwartz, N. P. Dupuis, T. Kusomoto, M. Liu,
F. Liu and D. Northey
Dana-Farber Cancer Institute and Joint Center for Radiation
Therapy, 44 Binney St., Boston, MA 02115

ABSTRACT

Human solid tumors (prostate carcinomas PC-3 and DU-145, breast carcinoma MX-1, cervical carcinoma ME-180, small cell lung carcinoma SW2, and glioblastoma T98G) were grown as xenografts in nude mice. Using the Eppendorf pO₂ histogram microelectrode system, the oxygen profiles of the tumors were determined while the animals breathed air or carbogen (95% O₂/5% CO₂), and after administration of the perfluorochemical emulsion Oxygent-CA (8 ml/kg) under air breathing and carbogen breathing conditions. Under normal air breathing with or without Oxygent-CA administration the mean oxygen tensions were between 4.9 and 9.3 mmHg and each tumor had severely hypoxic regions where the pO₂ was less than 5 mmHg. The severely hypoxic regions comprised 41-71% of the oxygen tension measurements under normal air breathing conditions. Carbogen breathing alone increased the mean oxygen tensions to 10.9-23.9 mmHg. Administration of Oxygent-CA and carbogen breathing increased the mean oxygen tensions over the levels of carbogen breathing alone to varying degrees. The highest mean oxygen tensions were 40.8 mmHg in the T98G glioblastoma and 24.5 mmHg in the ME-180 cervical carcinoma. Investigation of the use of Oxygent-CA/carbogen to increase the oxygenation of clinical tumors is warranted.

INTRODUCTION

Hypoxic cells in solid tumors are presumed to be an obstacle to successful cancer treatment because these cells are relatively protected from the cytotoxic effects of radiotherapy and certain anticancer drugs [1-4]. The importance of hypoxic cells in limiting the curability of human tumors remains a controversial issue, although some clinical [5, 6] and laboratory data [6-9] strongly suggest that hypoxic cells are a cause of *in vivo* treatment failure. With the greater availability of stable O₂-microelectrode systems suitable for use in the clinic, data supporting the notion that therapeutically significant hypoxia frequently exists in human tumors is rapidly accumulating [10-15].

One potential method for improving tumor oxygenation may be administration of a perfluorochemical emulsion and breathing a high oxygen content atmosphere. We have determined the oxygen tension profiles for six human solid tumors grown as xenografts in nude mice in the presence and absence of Oxygent-CA/carbogen breathing.

MATERIALS AND METHODS

Materials. Oxygent™CA is a highly concentrated (47% v/v, 90% w/v) perflubron emulsion and was supplied by Alliance Pharmaceutical Corp., San Diego, CA. The particle size of the emulsion is 0.2 μm. The circulating half-life of this emulsion, at the dosage tested, is 3-6 hrs. (Peter Keipert, personal communication) and the dwell time of perflubron in tissues is about 7 days [16]. Carbogen is 95% oxygen/5% carbon dioxide.

Tumors. DU-145 prostate carcinoma was isolated from a lesion in the brain of a patient with widespread metastatic prostate carcinoma. The DU-145 tumor is not hormone sensitive and was obtained from the ATCC.

PC-3 prostate adenocarcinoma was isolated from a grade IV tumor. The PC-3 exhibits low testosterone-5-α reductase activity and was obtained from the ATCC.

ME-180 cervical carcinoma was isolated from an omental metastases from a rapidly spreading cervical carcinoma. The ME-180 was obtained from the ATCC.

T98G glioblastoma was isolated from a glioblastoma multiforma tumor. The T98G was obtained from the ATCC.

MX-1 breast carcinoma, a poorly differentiated mammary carcinoma with high cellularity and no evidence of gland or mucin

production, was a gift from Dr. A. Ovejera of the DCT Tumor Repository, National Cancer Institute.

SW2 small cell lung carcinoma was initiated from pleural fluid obtained from a patient with small cell carcinoma. The SW2 tumor obtained as a gift from Dr. S. Bernal.

Oxygen measurements. Tissue oxygen measurements were made using a pO₂-Histogram (Eppendorf, Inc., Hamburg, Germany). The polarographic needle microelectrode was calibrated in aqueous solutions saturated with air and 100% nitrogen. The electrode was used to make tumor measurements if there was less than 1% variation in current measurements upon repetition of the calibration cycle. For tumor pO₂ measurements the animal was anesthetized by an i.p. injection of Ketaset (35 mg/kg) and xylazine (25 mg/kg) prepared in phosphate-buffered 0.9% saline. The animal was placed on a heating pad and covered with a blanket to maintain body temperature. Core temperature was monitored with a rectal thermometer. The tumor site was shaved and tumor diameters measured with calipers. A small patch of skin about 2 cm from tumor was shaved and a small incision was made allowing the reference electrode (Ag/AgCl-ECG) to be inserted subcutaneously and secured. The tumor was exposed by removing about 0.5 cm² of skin over the site. The tumor capsula was then perforated with a 20-gauge needle. The pO₂ microelectrode was positioned in the perforation.

The pO₂ microelectrode under computer control enters 1 mm into the tissue and then retracts 0.3 mm. Probe current is then measured and after 1.4 seconds the probe moves forward again. The total length of the measurement path is determined by the size of the tumor. After the probe reaches the end of its measurement path it automatically retracts. The probe was then repositioned in the same perforation at a different angle and stepwise measurements again initiated. Three diameters were measured in each tumor for a total of 40-60 measurements per condition.

Tumor pO₂ measurements were made under four conditions: (1) normal air breathing, (2) carbogen (95% O₂/5% CO₂) breathing, (3) 10 minutes post intravenous perflubron emulsion (8 ml/kg) administration with normal air breathing and (4) 15 minutes post the initiation of carbogen breathing after intravenous perflubron emulsion (8 ml/kg) administration.

Each tumor-bearing mouse underwent tumor pO₂ measurements under two experimental conditions, therefore each tumor was probed two times through three diameters. Data collection through three tumor diameters accrued about 50 pO₂ measurements and took about 10 minutes. The pO₂

microelectrode was recalibrated in aqueous solutions saturated with air and 100% nitrogen after each data collection, therefore the pO₂ microelectrode was recalibrated 4 times during the course of the experiment. Recalibration requires about 15 minutes. Overall, the duration required for tumor pO₂ measurements under the four conditions tested was about one hour and 40 minutes.

RESULTS

Under normal air breathing conditions each of the six human tumors contained substantial regions of severe hypoxia defined as regions in which the pO₂ was <5 mmHg (**TABLE 1**). The percent of oxygen measurements that were <5 mmHg ranged from 48% in the PC-3 prostate carcinoma to 70% in the DU-145 prostate carcinoma. Carbogen breathing impacted very little on the severely hypoxic regions of these tumors but did increase the pO₂'s of the better oxygenated portions of the tumors as evidenced by the increased mean/median and 90th percentiles pO₂ values.

Administration of the perflubron emulsion (Oxygent-CA) at a dose of 8 ml/kg under air breathing conditions did not alter the oxygenation of the tumors from that observed in the absence of the emulsion. When carbogen breathing was added to treatment with the perflubron emulsion there was a decrease in the percentage of tumor regions which were severely hypoxic. The greatest decreases in severe hypoxia occurred in the ME-180 cervical carcinoma (59% to 38%) and SW2 small cell lung carcinoma (64% to 45%). The perflubron emulsion and carbogen breathing also increased the oxygenation of the better oxygenated regions of the tumor to a level equal to or greater than levels seen with carbogen breathing.

DISCUSSION

The oxygen-carrying perfluorochemical emulsions have been shown to be effective in enhancing the effects of radiation therapy and chemotherapy in a wide variety of solid animal tumors [3, 17, 18]. The belief has been that the perfluorochemical emulsions/carbogen breathing act primarily by reducing hypoxia in the tumor. In solid tumor model systems hypoxic cells; have been shown to limit the response of neoplasms to treatment with ionizing radiation as well as to many chemotherapeutic agents [8, 9]; however, it has yet to be proven the hypoxia limits the response of clinical tumors [19]. Regions of hypoxia which could be considered therapeutically significant (5 mmHg or less) comprised

TABLE 1. Oxygenation Parameters Under Several Conditions for the Six Human Tumors Grown as Xenografts^a

Measurement condition	Mean/Median pO ₂ , mmHg	% of readings <5 mmHg	pO ₂ , mmHg percentiles	
			10th	90th
MX-1 CARCINOMA				
air	9.7/4.7	50	0.0	26.3
carbogen	14.7/4.7	50	0.2	39.1
Oxygent-CA (8 ml/kg):				
air	5.9/2.3	65	0.0	17.0
carbogen	21.5/6.7	44	0.0	33.5
PC-3 PROSTATE CARCINOMA				
air	9.3/6.4	48	0.0	21.3
carbogen	19.1/10.1	50	0.3	51.9
Oxygent-CA (8 ml/kg):				
air	6.9/5.7	41	0.0	16.9
carbogen	24.3/8.6	40	0.7	39.6
T98G GLIOBLASTOMA				
air	8.5/3.2	60	0.0	26.3
carbogen	12.4/3.3	58	0.0	35.5
Oxygent-CA (8 ml/kg):				
air	8.5/2.3	64	0.3	24.8
carbogen	40.8/7.5	43	0.6	68.5
SW2 SMALL CELL LUNG CARCINOMA				
air	5.4/3.0	64	0.0	13.3
carbogen	10.9/3.8	63	0.5	25.9
Oxygent-CA (8 ml/kg):				
air	5.2/2.8	56	0.3	5.6
carbogen	10.8/6.2	45	0.4	26.6
DU-145 PROSTATE CARCINOMA				
air	4.9/3.0	70	0.0	14.9
carbogen	13.2/4.8	69	0.0	40.1
Oxygent-CA (8 ml/kg):				
air	7.2/2.7	60	0.0	21.1
carbogen	21.9/4.9	58	0.0	53.0
ME-180 CERVICAL CARCINOMA				
air	6.2/3.6	59	0.0	14.9
carbogen	23.9/8.7	50	0.6	58.6
Oxygent-CA (8 ml/kg):				
air	10.6/5.4	42	0.0	24.2
carbogen	24.5/10.4	38	0.6	59.6

^aThese data represent 400-600 measured pO₂ values per condition therefore 10 tumors were probed under each measurement condition.

a substantial portion of all six tumors in this study. The mixed character of the tumors that is human malignant cells and murine vasculature may contribute to the degree of hypoxia in these tumors. Clinical study of the effect of perfluorochemical emulsions/carbogen or oxygen breathing is warranted.

ACKNOWLEDGMENT. This work was supported by NIH grant PO1-CA19589 and a grant from Alliance Pharmaceutical Corp., San Diego, CA.

REFERENCES

1. K. A. Kennedy, B. A. Teicher, S. A. Rockwell, A. C. Sartorelli. *Biochem. Pharmacol.*, 29:18, (1980).
2. K. A. Kennedy, B. A. Teicher, S. A. Rockwell, A. C. Sartorelli. New York: Academic Press, 1981: 85.
3. B. A. Teicher, C. M. Rose. *Int. J. Radiat. Oncol. Biol. Phys.*, 12:1311-1313, (1986).
4. B. A. Teicher, J. S. Lazo, W. W. Merrill, A. E. Filderman, C. M. Rose. *Cancer Chemother. Pharmacol.*, 18:213-218, (1986).
5. P. M. Busse, S. K. Bose, R. W. Jones, L. J. Tolmach. *Radiat. Res.*, 71:666, (1977).
6. W. Duncan. *Br. Med. Bull.*, 29:33, (1973).
7. J. R. Fowler, R. H. Thomlinson, A. E. Howes. *Eur. J. Cancer*, 6:207, (1970).
8. A. C. Sartorelli. *Cancer Res.*, 48:775, (1988).
9. B. A. Teicher, J. S. Lazo, A. C. Sartorelli. *Cancer Res.*, 41:73-81, (1981).
10. P. Vaupel, K. Schlenger, C. Knoop, M. Höckel. *Cancer Res.*, 51:3316-3322, (1991).
11. P. Vaupel. *Strahlenther Onkol.*, 166:377-386, (1990).
12. F. Kallinowski, R. Zander, M. Höckel, P. Vaupel. *Int. J. Radiat. Oncol. Biol. Phys.*, 19:953-961, (1990).
13. R. A. Gatenby, H. B. Kessler, J. S. Rosenblum, L. R. Coia, P. J. Moldofsky, W. H. Hartz, G. J. Broder. *Int. J. Radiat. Oncol. Biol. Phys.*, 14:831-838, (1988).
14. W. Fleckenstein. Berlin: Blackwell Ueberreuter Wissenschaft, 1990: 81-90.
15. P. Vaupel. *Oxygenation of solid tumors.* In: *Drug Resistance in Oncology.* Teicher BA ed. New York, NY: Marcel-Dekker 53-85, 1993.

16. J. G. Riess. *Artif. Organs*, 8:44-56, (1984).
17. B. A. Teicher, T. S. Herman, S. M. Jones. *Cancer Res.*, 49:2693-2697, (1989).
18. S. Rockwell, C. G. Irvin, M. Kelley, C. S. Hughes, H. Yabuki, E. Porter, J. J. Fischer. *Int. J. Radiat. Oncol. Biol. Phys.*, 22:87-93, (1991).
19. P. Okunieff, E. P. Dunphy, M. Hoeckel, D. J. Terris, P. Vaupel. *Adv. Exp. Med. Biol.*, :0-00, (in press, 1992).

OXYGENATION DURING PERFLUOROCARBON ASSOCIATED GAS
EXCHANGE IN NORMAL AND ABNORMAL LUNGS.

LJ Hernan, BP Fuhrman, MC Papo, CL Leach, AE Thompson, FD Nesti, N Salman, DM Steinhorn, W Novotny, P Paczan, B Burak, M Rath.
Children's Hospital of Buffalo, New York and Children's Hospital
of Pittsburgh, Pennsylvania. Pediatric Critical Care, Children's
Hospital of Buffalo, 219 Bryant Street, Buffalo, New York 14222

ABSTRACT:

Perfluorocarbon-associated gas exchange (PAGE) has been proposed for the treatment of lung diseases characterized by high alveolar surface tension. Perflubron (perfluorooctyl bromide, LiquiVenttm, Alliance Pharmaceutical Corp.) is a high purity medical grade perfluorocarbon suitable for PAGE. We studied PAGE using perflubron in normal piglets and in animal models of pulmonary disease (meconium aspiration syndrome, oleic acid infusion and gastric acid aspiration as models of ARDS, and neonatal respiratory distress syndrome).

All animals were studied under anesthesia. PAGE was instituted by intratracheal instillation of a volume of perflubron (generally 30 ml/kg) that approximates a normal functional residual capacity of the lung. Arterial blood gases were measured at 15 minute intervals. FiO_2 during PAGE was 1.0.

In normal piglets, PaO_2 fell from 543 torr (during conventional gas breathing) to 363 torr (during PAGE). However, in models of lung disease, PAGE significantly enhanced PaO_2 .

INTRODUCTION:

Tidal liquid breathing has been shown effective in several animal models of lung disease characterized by abnormally high surface tension. It has recently been shown that gas ventilation of the perfluorocarbon-filled lung can be accomplished in normal animals at airway pressures that are comparable to those during conventional continuous positive pressure breathing (CPPB)[1]. This mode of respiratory support is called perfluorocarbon-associated gas exchange (PAGE) or partial liquid ventilation (PLV).

The studies summarized in this report test the efficacy of PAGE using perflubron (LiquiVenttm) in normal piglets and in models of lung disease: meconium aspiration syndrome (MAS), oleic acid (OA) infusion and gastric acid (GA) aspiration models of ARDS, and neonatal respiratory distress syndrome (RDS).

METHODS:

All animals were instrumented and studied under anesthesia and neuromuscular blockade. All studies were performed on 100% oxygen.

Normal group: Six piglets (9 - 14 days old, weighing 2.26 - 4.74 kg) underwent tracheostomy and volume controlled CPPB. Tidal volume was 15 ml/kg, PEEP was 4 cm H₂O, inspiratory time was 25%, FiO₂ was 1.0, and respiratory rate was 20 to 26 breaths per minute. Minute ventilation was adjusted to achieve a PaCO₂ between 35 and 45 torr. Ventilator settings were held constant throughout the course of the experiment. Gas breathing was followed by PAGE. PaO₂ during CPPB was compared to PaO₂ during PAGE.

MAS group: Sixteen piglets less than 10 days old were ventilated with an FiO₂ of 1.0. Mechanical ventilation was adjusted to obtain a control PaCO₂ of 35 to 45 torr. Four ml/kg of a 33% slurry of human meconium was instilled into the trachea of each piglet. Eight piglets continued CPPB and eight piglets underwent PAGE. PaO₂ of piglets receiving CPPB was compared to PaO₂ of piglets treated with PAGE.

OA group: Eight piglets (2.66 ± 0.19 kg) were ventilated with volume controlled CPPB. Tidal volume was 15 ml/kg, PEEP was 4 cm

H₂O, inspiratory time was 25%, respiratory rate was 20 breaths per minute, and FiO₂ was 1.0. Oleic acid was infused over 30 minutes to induce ARDS. Four piglets were treated with PAGE and four piglets continued CPPB. PaO₂ of piglets in the PAGE group was compared to PaO₂ of piglets in the CPPB group.

GA group: Eleven piglet (2.2 - 4.1 kg) were ventilated with volume controlled CPPB. Tidal volume was 15 ml/kg, PEEP was 4 cm H₂O, inspiratory time was 25%, and FiO₂ was 1.0. Respiratory rate was between 20 and 26 breaths per minute to achieve a control PaCO₂ between 35 and 45 torr. One ml/kg of homogenized gastric aspirate (pH = 1.0) was instilled into the trachea to induce ARDS. After 60 minutes, PAGE was instituted in six piglets while five piglets continued CPPB. Ventilator settings were held constant in both groups. PaO₂ of piglets treated with PAGE was compared to PaO₂ of piglets continuing CPPB.

RDS group: Seven surfactant deficient premature lambs were delivered by hysterotomy at a gestational age of 125 to 128 days. They were ventilated with pressure controlled CPPB with an FiO₂ of 1.0. After 30 minutes of CPPB, PAGE was instituted and continued for 4 hours. PaO₂ during CPPB was compared to PaO₂ during PAGE. Statistics: Significance of differences were evaluated by ANOVA. Where appropriate, post hoc tests were adjusted for multiple comparisons.

RESULTS:

In normal piglets, PaO₂ decreased from 540 to 360 torr on institution of PAGE, illustrating the inefficiency of gas exchange through a liquid medium in the normal lung. In models of lung disease, however, introduction of perflubron into the trachea recruited lung segments not readily oxygenated by conventional CPPB, and thereby improved oxygenation (p<.05). In fact, in models of neonatal respiratory distress syndrome and ARDS (oleic acid infusion and gastric acid aspiration), the PaO₂ achieved during PAGE approached that achieved by PAGE in normals.

TABLE I

	$P_{aO_2} \pm$ sd (torr) CPPB	during CPPB and PAGE PAGE
Normals	540 \pm 50	360 \pm 90
Neonatal RDS	50 \pm 30	350 \pm 80
GA ARDS	100 \pm 20	350 \pm 60
OA ARDS	50 \pm 40	280 \pm 80
MAS	70 \pm 40	180 \pm 30

(samples obtained immediately before and at termination of PAGE)

CONCLUSIONS:

PAGE with perflubron significantly improved oxygenation in animal models of the meconium aspiration syndrome, ARDS, and neonatal RDS.

REFERENCES

- (1) BP Fuhrman, PR Paczan, M DeFrancis. Perfluorocarbon associated gas exchange. Crit Care Med 19(5):712-723 (1991)

**LONG-TERM PARTIAL LIQUID VENTILATION (PLV) WITH
PERFLUBRON IN THE NEAR-TERM BABOON NEONATE**

K.M. Sekins¹, J.J. Coalson², R.A. deLemos³, T.K. Fields¹, S.F. Flaim¹,
J.M. Guerra⁴, R.M. Hopkins¹, J.C. Jackson⁵, D.M. Null⁶, D.C. Winter⁴;
¹Alliance Pharmaceutical Corp., San Diego, CA.; ²U. of Texas Health Science
Center, San Antonio, TX, ³U of Southern California Medical Center, Los Angeles,
CA.; ⁴ Southwest Research Institute, San Antonio, TX.; ⁵U. of Washington,
Seattle, WA.; ⁶Wilford Hall USAF Medical Center, San Antonio, TX.

ABSTRACT

Purpose: The feasibility and safety of continuous long-term (4-5 day) partial liquid ventilation (PLV) using perflubron was demonstrated in newborn baboons. PLV, a potential therapy for adult and neonatal respiratory distress syndrome (RDS), is conventional mechanical ventilation (CMV) with the lung filled to about functional residual capacity with perfluorochemical liquid.

Protocol: As a pilot trial for a larger preclinical study focused on the safety of extended duration PLV, three near term baboons were studied. The animals were delivered by cesarean section, anesthetized, intubated and placed on CMV. The animals were given intratracheal perflubron (30 ml/kg) and maintained on PLV for 96 hours. The transition back to gas ventilation occurred, after draining, over the fifth day (hrs 96-120).

Results: Two of the animals were born with normal pulmonary function, while the third developed respiratory distress prior to PLV. All the animals were adequately supported with PLV using moderate ventilator settings and low concentrations of oxygen. Perflubron distribution was enhanced by periodic rotation of the animals. Preliminary histology show vacuolated alveolar macrophages and no evidence of edema or other significant changes in the lungs. Pulmonary function in the RDS animal, after PLV treatment, showed normal gas exchange and lung mechanics.

Conclusions: Three near term baboons, one with clinical RDS, tolerated 4 days of PLV followed by 1 day of CMV without complications using practical clinical management methods.

INTRODUCTION

While perfluorochemical (PFC) liquid ventilation has been researched for many years [1], the reliability and safety of these procedures in prolonged experiments representative of clinical treatment durations have not been established. Further, the toxicity associated with extended PFC exposure in the lung has not been adequately evaluated. Liquid ventilation experiments reported in the literature have been limited to approximately 8 hours[2]. Before liquid breathing therapy can be routinely used clinically, the safety of multiple-day treatments must be demonstrated, ideally in a manner which is minimally traumatic to the patient, logistically manageable, not prone to human error or device failure, and which uses a PFC known to be safe for long tissue exposures.

Perflubron PLV and RDS Intratracheal administration of perflubron (perfluorooctylbromide, PFOB) offers a promising method of ventilatory support in both adult respiratory distress syndrome (ARDS) and infant respiratory distress syndrome (IRDS). The technique involves neat sterile perflubron being introduced into the lung during concomitant CMV at a dose approximately equivalent to the normal gas functional residual capacity (FRC) of the patient's lungs. This process of extended CMV support of the PFC-filled (or partially filled) lung is termed "partial liquid ventilation", or PLV. This is distinguished from "total" liquid ventilation in which a liquid ventilator is used, with tidal flow of liquid (no gas) into and out of the lung. PLV is also termed Perfluorocarbon Associated Gas Exchange, PAGE[3].

Potential Advantages of PLV over Conventional Therapy Perflubron PLV has been shown to improve gas exchange and lung compliance in several animal models of lung injury (both IRDS and ARDS)[4]. In addition, it has several potential advantages over exogenous surfactant (ES) therapy. Due to perflubron's physical properties (e.g., spontaneous spreading coefficient and low surface tension)[5] and the large volume dose employed, it has the potential to more completely and uniformly inflate the lung. Because perflubron is radioopaque it permits imaging to help in assessing PLV liquid distribution in the lung.

Perflubron can be administered without the transient hypoxia or hypercapnia often associated with ES administration due to its high O₂ and CO₂ solubilities. In addition, its low surface tension and positive spreading coefficient appear to act to recruit more lung volume, increase lung compliance and lower the airway pressures needed to open and sustain physiologic ventilation. It is speculated that the presence of a breathable liquid in the alveoli also prevents end-expiratory collapse while sustaining O₂ delivery and CO₂ removal following end-expiration. Further, recent observations support the notion that the presence of perflubron in the alveoli may also produce a tamponade effect which reduces leakage of fluids into the airway across the alveolar capillary membrane[6]. Unlike surfactants,

perflubron is not biochemically inhibited by proteinaceous edema. Further, perflubron has no foreign proteins (as for animal-derived surfactants) and does not promote bacterial growth.

MATERIALS AND METHODS

Three near term baboons (165-171 days gestational age; term=182 days) were delivered by hysterotomy, resuscitated and placed on CMV (Infant Star, Infrasonics, San Diego, CA.) for 1 to 3 hours of stabilization. The animals were anesthetized with I.V. ketamine (5 mg/kg), and fentanyl (5 μ g/kg) was used as needed for analgesia. Arterial and venous umbilical catheters were placed and prophylactic antibiotics administered every 12 hours. Paralysis of the respiratory musculature was induced and maintained with pavulon (\approx 0.1 mg/kg every 4 hours). Animals were maintained on I.V. fluids throughout the experiment and maternal blood was used as donor blood to replace sampling losses on a volumetric basis.

Monitored and recorded data included vital signs (blood pressure, body temperature and heart rate) taken hourly or as needed for the first 24 hours, and thereafter every two hours. A standard battery of blood gases (every 4 hours or as needed), electrolytes, hematology and chemistries (daily), and A-P and lateral chest x-rays (every 8 hours or as needed). M-mode and Doppler echocardiography were performed daily to assess the closure of the patent ductus arteriosus (PDA). Non-invasive pulmonary function tests performed daily included static compliance, dynamic pressure-volume loops, and passive exhalation airway resistance and compliance.

Partial liquid ventilation was instituted for 96 continuous hours by administering the first perflubron dose (\approx 30 ml/kg) at the end of the stabilization period, and then maintaining an approximate FRC of liquid in the lungs by supplemental doses given about once per hour to replace evaporative losses. Supplemental dosing (and thus measurement of evaporative loss) was performed by maintaining an approximately constant meniscus level in the endotracheal tube under positive end-expiratory pressure (PEEP) of 2 cmH₂O. Based on an earlier study demonstrating an improvement in liquid distribution following animal rotation [6], the baboons in this study were rotated during initial and supplemental dosing. Lateral and AP chest x-rays showed generally uniform distribution throughout the PLV treatment.

At 96 hours further supplemental perflubron dosing was stopped and as much perflubron as possible was drained from the lung by gravity. Mechanical ventilation was then maintained for the final 24 hours, with blood gases being monitored to determine ventilator adjustments to accommodate changes in oxygenation and ventilation occurring during the transition back to gas breathing.

FIGURE 1A. At Birth - Prior to Filling

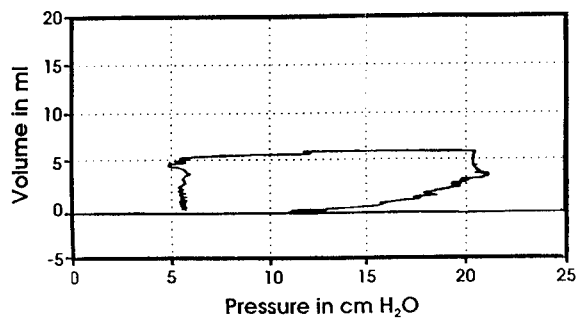

FIGURE 1B. Perflubron-Filled Lung at 24 hours

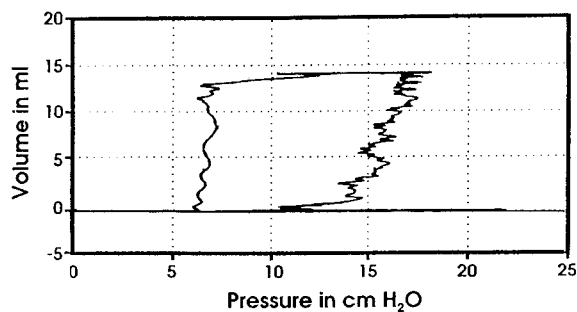

FIGURE 1A-1B. Pressure-volume curves in baboon #3: (non-RDS animal) after birth prior to perflubron filling (1A) and 24 hours into PLV treatment (1B).

RESULTS AND DISCUSSION

Safety Data All animals were successfully ventilated with perflubron PLV for the entire protocol without complication using standard clinical neonatal intensive care staffing and procedures. PDAs in all animals closed normally during the PLV treatment period. Ventilator settings, characterized for both steady state treatment periods and the dosing intervals, showed that only moderate airway pressures (peak inspiratory pressures [PIP] =14-22 cmH₂O, PEEP≤6 cmH₂O), breathing rates (16-25 bpm) and inspired oxygen (FIO₂=0.35-0.40) were required to produce acceptable oxygenation and ventilation. The rate of perflubron evaporative loss was 1.5-2.0 ml/kg/hr.

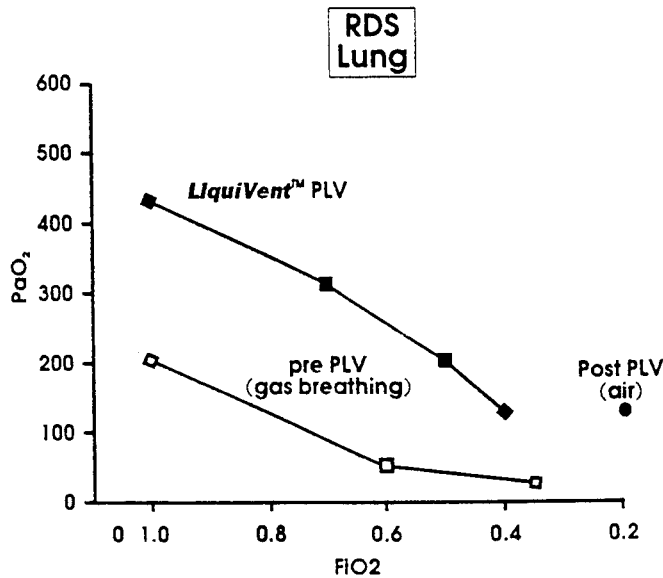

FIGURE 2. Comparison of arterial oxygenation (PaO_2) as a function of inspired fraction of oxygen (FIO_2) in a newborn baboon with RDS, before, during and 24 hours after perflubron PLV. All PLV measurements were taken during during the first hour of the treatment. Comparable ventilator settings were used for all measurements.

Figure 1a-1b show sequential dynamic pressure-volume (P-V) curves for a normal (non-RDS) animal, both before perflubron dosing and during PLV at 24 hours into the treatment. The figures demonstrate that an apparent increase in dynamic lung compliance was observed during PLV. It is important to appreciate, however, that measurements of dynamic P-V loops made during air breathing CMV may not be directly comparable to those made during perflubron PLV. This follows, in part, from the observation that the FRC volume was not always precisely known. However, P-V curves taken at 24 hrs after cessation of PLV show loops very similar to Figure 1a, indicating that the pre- and post-treatment compliance were about the same in the normal lung when evaporative removal was nearly complete.

Preliminary morphologic findings show no evidence of edema, fibrosis or other lung abnormalities in any of the animals. Some vacuolated alveolar macrophages were noted. Perflubron uptake by macrophages is commonly reported in studies of I.V. administration of PFC emulsions.

Efficacy Data Two of the baboons were born with normal newborn pulmonary function, while the third developed (prior to PLV) clinical indications of hyaline membrane disease. Figure 2 shows that 100% inspired oxygen during PLV produced extremely high PaO₂ (>400 mmHg) in the RDS lung. This permitted FIO₂ to be routinely operated for most of the treatment period at levels considered safe for long term exposure (0.35-0.40). Significantly, normal blood gases were achieved in the RDS lung on air breathing (FIO₂=0.21), 24 hours after PLV administration ceased.

CONCLUSIONS

Four days of perflubron PLV followed by 1 day of CMV appears feasible and can be accomplished with relatively simple respiratory management techniques. No apparent adverse effects occurred in the three animals tested. For example, preliminary results from histology indicate that the treatment did not lead to lung barotrauma. In addition, the potential efficacy of PLV in the management of infants with RDS was supported by measured improvements in gas exchange in a baboon with RDS. While these data are preliminary, the findings of approximately normal gas exchange and compliance 24 hours post-treatment also indicate that the treatment did not significantly inhibit nor deplete pulmonary surfactant.

REFERENCES

1. TH Shaffer, MR Wolfson and LC Clark: Liquid Ventilation. *Pediatric Pulmonology*, Vol. 14, pp.102-109 (1992).
2. JH Modell, EJ Newby and BC Ruiz: Long-term Survival of Dogs after Breathing Oxygenated Fluorocarbon Liquid. *Federation Proceedings*, Vol. 29, No. 5, pp. 1731-1736 (1970).
3. BP Fuhrman, PR Paczan and M DeFrancis: Perfluorocarbon-associated Gas Exchange. *Critical Care Medicine*, Vol. 19, No. 5, 712-722 (1991).
4. LJ Hernan, BP Fuhrman, MC Papo, CL Leach, AE Thompson, F Nesti., N Salman, D. Steinhorn, W Novotny, P Paczan, B Burak, and M Rath: Oxygenation During Perfluorocarbon-Associated Gas Exchange in Normal and Abnormal Lungs, *Vth International Society of Blood Substitutes*, San Diego, CA, (March 20, 1993).
5. Riess JG: Overview on Progress in the Fluorocarbon Approach to in vivo Oxygen Delivery. In; *Blood Substitutes and Oxygen Carriers*, Chang TMS (ed), M. Dekker, New York, 1993, pp. 24-43.

6. JC Jackson, KM Sekins KM, TA Standeart and JK Hoffman: Pilot Study: Comparison of Total Liquid Ventilation and Endotracheal Dosing Techniques as Prerequisites to Partial Liquid Ventilation in Small and Large Normal and RDS Lungs. Report, Alliance Pharmaceutical Corp., (Aug. 1992).

LUNG MANAGEMENT WITH PERFLUOROCARBON LIQUID VENTILATION
IMPROVES PULMONARY FUNCTION AND GAS EXCHANGE DURING
EXTRACORPOREAL MEMBRANE OXYGENATION (ECMO)

RB Hirschl, M.D., A Parent, B.S., R Tooley, M.D.,

T Shaffer, Ph.D., M Wolfson, Ph.D., and RH. Bartlett, M.D.

The Department of Surgery, University of Michigan, Ann Arbor, Michigan; and The
Department of Physiology, Temple University School of Medicine, Philadelphia,
Pennsylvania, U.S.A.

ABSTRACT

We investigated whether pulmonary function and gas exchange would improve with liquid perfluorocarbon ventilation (LV) during ECMO for severe respiratory failure. Lung injury was induced in 11 young sheep 15.1 ± 3.7 kg in weight utilizing right atrial injection of 0.07 cc/kg oleic acid followed by saline pulmonary lavage. When $(A-a)DO_2 \geq 600$ mmHg and $PaO_2 \leq 50$ mmHg with $FiO_2 = 1.0$, ECMO was instituted. Animals were then ventilated with either standard ECMO "lung rest" gas ventilator settings (ECMO, n=5) or with "total" liquid ventilation at standard ventilator device settings (LIQ-ECMO, n=6) utilizing perflubron (perfluooctyl bromide, LiquiventTM; Alliance Pharmaceutical Corp.). After 3 hours on ECMO, pulmonary physiologic shunt decreased (ECMO = $88 \pm 11\%$ vs LIQ-ECMO = $31 \pm 1\%$; $p < .001$) and pulmonary compliance increased (ECMO = 0.50 ± 0.06 cc/cmH₂O/kg vs. LIQ-ECMO = 1.04 ± 0.19 cc/cmH₂O/kg; $p < .001$). The ECMO flow rate required to maintain the PaO_2 in the 50-80 mmHg range was decreased significantly (ECMO = 116 ± 14 ml/kg/min vs. LIQ-ECMO = 14 ± 5 ml/kg/min; $p < .001$). In this model requiring extracorporeal support for severe respiratory failure, lung management with liquid ventilation improves pulmonary function and gas exchange.

INTRODUCTION

Extracorporeal membrane oxygenation (ECMO) is utilized to provide prolonged cardiopulmonary support in neonatal, pediatric, and adult patients with severe acute respiratory failure (ARF).[1] ECMO allows application of the concept of "lung rest" and avoidance of the deleterious effects of high pressure ventilation and oxygen toxicity.[2] However, there is often no specific lung management implemented during ECMO to enhance lung healing or pulmonary function.

Pulmonary gas exchange utilizing liquid breathing has been investigated over the last 25 years.[3] Full-term, as well as premature, lambs and other animals may be supported for long periods via perfluorocarbon breathing.[4] The improved efficacy of liquid ventilation when compared to gas ventilation in newborn lambs with acute respiratory failure secondary to intravenous oleic acid injection has been demonstrated.[5] The demonstration of improved gas exchange and support in an acute lung injury model of respiratory failure made us question whether pulmonary function might not be improved through use of liquid ventilation during ECMO.

METHODS

11 young sheep 15.1 ± 3.7 kg in weight were anesthetized with a guaifenesin/ketamine mixture (50g guaifenesin/liter and 1g ketamine/liter, 2.2 ml/kg administered for initial anesthesia with titration to effect). A midline neck incision was performed and the trachea isolated and cannulated. The right carotid artery as well as both internal jugular veins were identified. An 18 gauge catheter was placed into the carotid artery and advanced approximately 3 cm and anchored in place. A 5 French balloon-tipped catheter was advanced into the pulmonary artery under transduced pressure guidance via the right femoral vein. Heparin 100 units/kg were administered intravenously. A venous drainage cannula was placed via the left internal jugular vein into the right atrium and anchored in place. A reinfusion cannula was placed into the right internal jugular vein and anchored in place. The connectors to the two cannulae were placed and flushed. Venovenous bypass was instituted, but the membrane lung was capped such that gas exchange did not take place. Pancuronium 0.1 mg/kg was administered intravenously and mechanical ventilation initiated. An anesthetic infusion of the guaifenesin/ketamine mixture was started at a rate of 2.2 ml/kg/hr. The animal was allowed to stabilize. Arterial blood gas, hemoglobin and oxygen saturation data were monitored utilizing an ABL-30 blood gas analyzer (Radiometer A/S, Copenhagen, Denmark) and an IL 282 co-oximeter (Instrumentation Laboratories, Lexington, Mass). Baseline static compliance was assessed by sequential

endotracheal tube injections of 4 ml/kg of air during gas ventilation and 4 ml/kg of perflubron (perfluorooctyl bromide, LiquiventTM, Alliance Pharmaceutical Corp.; San Diego, California) during liquid ventilation at 2 second intervals to a maximum of 20 cc/kg with transduced carinal pressure measurements evaluated by a Grass polygraph. Baseline transpulmonic shunt fraction (Q_{PS}/Q_T) and the alveolar-arterial oxygen gradient [(A-a)DO₂] were calculated based on assessment of arterial O₂ content, mixed venous (pulmonary artery catheter) O₂ content, alveolar end-capillary O₂ content, and PaCO₂ utilizing the following equations:

$$Q_{PS}/Q_T = (C_{iO_2} - C_{aO_2}) / (C_{iO_2} - C_{vO_2})$$

Where Q_{PS} = physiologic shunt; Q_T = cardiac output; C_{aO_2} = O₂ content of arterial blood; C_{vO_2} = O₂ content of mixed venous blood; and C_{iO_2} = O₂ content of the blood draining from the ideal alveolus, as derived from the alveolar gas equation and the O₂ dissociation curve; and

$$(A-a)DO_2 = PAO_2 - PaO_2$$

Where $PAO_2 = (F_{iO_2} - 47) - (PaCO_2/RQ)$, assuming $RQ = 0.8$. Venovenous bypass allowed measurement of Q_{PS}/Q_T despite the influence of extracorporeal support upon gas exchange.

Oleic acid (Mallinckrodt, C₁₈H₃₄O₂) 0.07 ml/kg was then injected and flushed into the right atrium through the pulmonary artery catheter over 5 minutes. In addition, normal saline lung lavage 35 ml/kg was performed three times at 5 minute intervals. The F_{iO_2} was increased to 1.0 and ventilator pressures adjusted to maintain the PaCO₂ < 45 mmHg. Compliance, Q_{PS}/Q_T , (A-a)DO₂, and arterial blood gas measurements were obtained every 15 minutes. Once the (A-a)DO₂ ≥ 600 mmHg and PaO₂ < 50 mmHg with $F_{iO_2} = 1.0$, gas exchange and, therefore, support with ECMO was initiated and lung management was randomized to one of two techniques:

- 1) Lung management in 5 animals was performed with gas ventilation at standard ECMO "lung rest" ventilator settings (ECMO group) which included a peak inspiratory pressure (PIP) of 20 cmH₂O, a positive end-expiratory pressure (PEEP) of 4 cmH₂O, and a rate of 10 breaths/minute.[2] F_{iO_2} was maintained at 1.0.
- 2) Lung management in 6 animals was performed with perfluorocarbon liquid ventilation (LIQ-ECMO group). The lungs were filled with perflubron 35cc/kg. A liquid ventilator was attached to the endotracheal tube and "total" or tidal volume liquid ventilation was performed at standard ventilator settings which included a tidal volume of 15 cc/kg, a rate of 5 breaths per minute, and an inspiratory to expiratory ratio of 1:2.[4] F_{iO_2} of the liquid ventilator sweep flow was maintained at 1.0 which resulted in a perfluorocarbon $PiO_2 \approx 700$ mmHg.

Venovenous extracorporeal support in all groups was adjusted to maintain the arterial blood gas values with a $\text{PaCO}_2 = 35\text{-}45$ mmHg and $\text{PaO}_2 = 50\text{-}80$ mmHg. Heparin 100 units/kg and pancuronium 0.1 mg/kg were administered intravenously every hour. Compliance, blood gas, and QPS/QT data were assessed every half hour. After 3 hours, final compliance, QPS/QT, and blood gas data were obtained. Statistical comparison of the data from the ECMO and LIQ-ECMO animal groups was performed utilizing the student t-test and data presented as mean \pm S.D.

RESULTS

The calculated physiologic shunt (QPS/QT) is demonstrated in figure 1. Physiologic shunt was $15\% \pm 6\%$ at baseline in both groups and increased to approximately $66\% \pm 9\%$ after induction of lung injury. After 30 minutes on ECMO both animal groups remained gas ventilated. With initiation of liquid ventilation significant and sustained reductions in physiologic shunt were noted which continued for the duration of the 3 hours that the animals were supported with ECMO. After 3 hours on ECMO the physiologic shunt in the ECMO group was $88 \pm 11\%$ and in the LIQ-ECMO group was $31 \pm 1\%$.

The pulmonary compliance as measured at 20 cc/kg inflation volume is demonstrated over time in figure 2. Baseline compliance was 1.42 ± 0.45 cc/cmH₂O/kg in the ECMO group and 1.26 ± 0.28 cc/cmH₂O/kg in the LIQ-ECMO group. After induction of lung injury the compliance at 20 cc/kg inflation volume in the ECMO group decreased to 0.58 ± 0.10 cc/cmH₂O/kg and in the LIQ-ECMO group to 0.51 ± 0.11 cc/cmH₂O/kg. At 30 minutes on ECMO both groups of animals remained gas ventilated. With initiation of liquid ventilation substantial and significant improvements in compliance were observed with the compliance after 3 hours on ECMO 0.53 ± 0.10 in the ECMO group and 1.04 ± 0.21 in the LIQ-ECMO animals.

With initiation of LV, a significant reduction in the ECMO flow rate required to maintain the PaO_2 in the 50-80 mmHg was observed and is demonstrated in figure 3. Required ECMO flow rate after 3 hours of extracorporeal support was 14 ± 5 cc/kg/min in the LIQ-ECMO group which was substantially less than the 116 ± 14 cc/kg/min flow rate required in the ECMO group.

DISCUSSION

In this study, a model of respiratory failure of such severity as to require ECMO was utilized to compare the efficacy of lung management between "lung

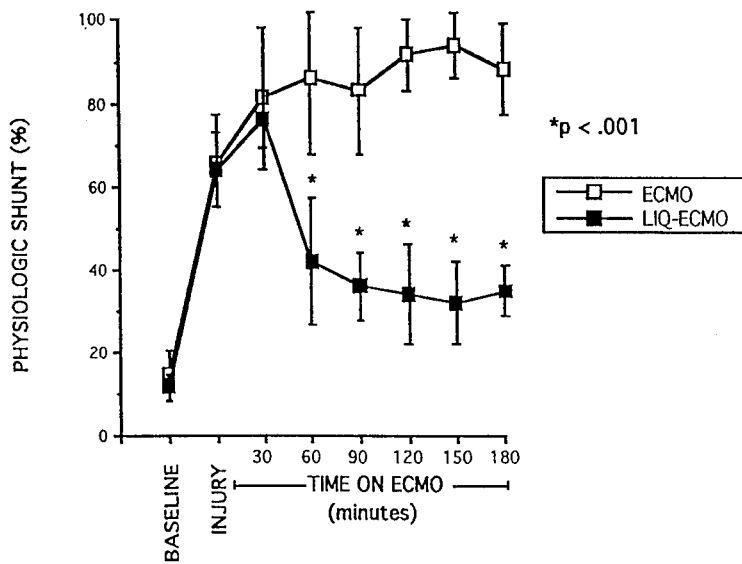

FIGURE 1: Physiologic shunt with standard "lung rest" pulmonary management during ECMO (ECMO) and with liquid ventilation during ECMO (LIQ-ECMO). (* $p < .001$)

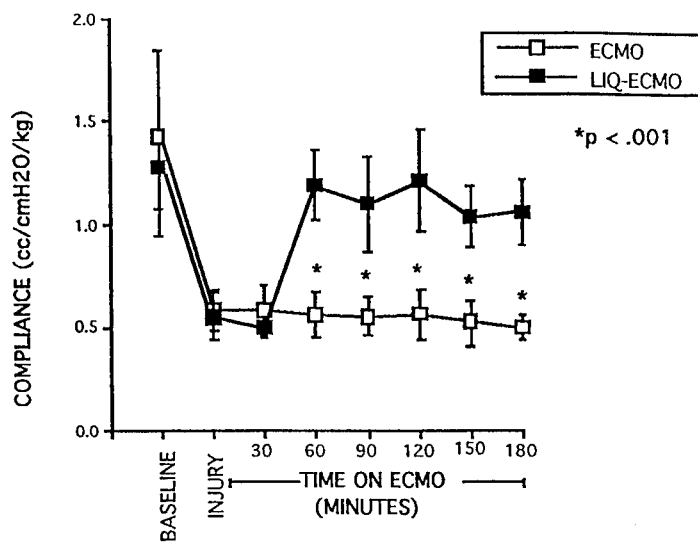

FIGURE 2: Pulmonary compliance at inflation to 20 ml/kg with standard "lung rest" pulmonary management during ECMO (ECMO) and with liquid ventilation during ECMO (LIQ-ECMO) (* $p < .001$)

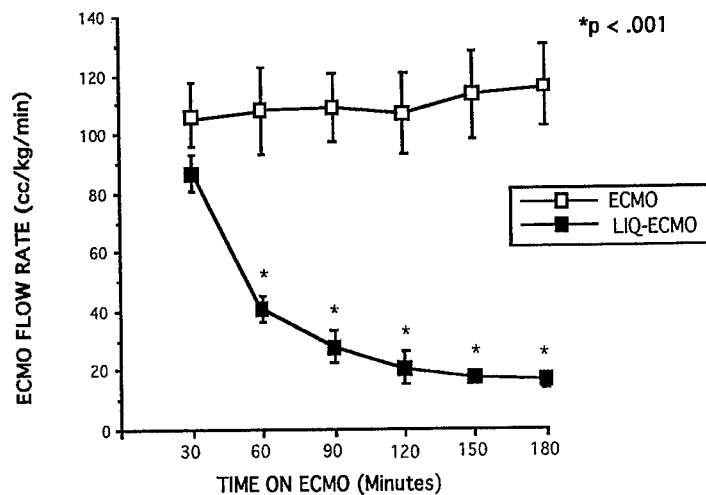

FIGURE 3: The ECMO flow rate required to maintain the PaO₂ in the 50-80 mmHg range with standard "lung rest" pulmonary management during ECMO (ECMO) and with liquid ventilation during ECMO (LIQ-ECMO) (* p < .001)

rest" gas ventilation and total liquid ventilation during ECMO. Typical ECMO "lung rest" gas ventilator and standard liquid ventilation device settings were utilized.[1,2] The data clearly demonstrate that pulmonary function and gas exchange are improved during liquid ventilation in this model of severe respiratory failure on ECMO.

ECMO is a technique which provides cardiopulmonary support in the setting of severe respiratory failure.[1,2] Extracorporeal support allows for a decrease in ventilator pressures as well as in FiO₂ while adequate oxygenation and carbon dioxide elimination are maintained. Thus lung rest and avoidance of pulmonary parenchymal injury is achieved during periods of severe respiratory failure. Unfortunately, onset of extracorporeal support is often accompanied by the development of bilateral pulmonary opacification noted radiologically with associated deterioration in pulmonary function and gas exchange.[6,7] The etiology for this diffuse pulmonary opacification is unclear, but probably is secondary to cessation of high ventilator pressures associated with severe and diffuse atelectasis. Another possible etiology for this bilateral pulmonary

opacification includes pulmonary capillary leak secondary to blood surface interactions at onset of bypass with a concomitant inflammatory-mediated response. Whatever the mechanism, this dense pulmonary opacification results in an initial deterioration in pulmonary function and gas exchange with associated prolongation of the time course during which extracorporeal support is necessary.[8] In addition, the mortality in the setting of severe respiratory failure requiring ECMO in the non-neonatal population is still approximately 50%.[9] This mortality is multifactorial, but is often directly related to the persistent atelectasis, the widespread organization of intra-alveolar exudates, and the associated pulmonary fibrosis which results in irreversible lung failure and eventual death.[10] A means, therefore, for providing effective alveolar recruitment and overall improvement in pulmonary function and gas exchange during ECMO would be desirable.

Many methods of lung management have been applied in an attempt to improve pulmonary function and outcome during ECMO and acute respiratory failure. The use of high levels of positive end-expiratory pressure (PEEP), the application of inverse ratio ventilation (IRV), and the administration of surfactant have all been utilized with minimal efficacy.[11,12] However, multiple factors would suggest that liquid ventilation would improve gas exchange and pulmonary function in the setting of ARF on ECMO. The alveolar surface tension in the perfluorocarbon-filled lung is approximately half that of normal lungs filled with air.[13] Therefore, liquid ventilation may be beneficial in inducing alveolar recruitment in the setting of atelectasis and surfactant-depletion such as that seen in the patient with respiratory failure on ECMO.[14] Pulmonary surfactant is immiscible in PFC so that further surfactant depletion is not promoted.[15] In addition, the intra-alveolar fluid present in the setting of severe respiratory failure may be effectively lavaged, removed, and/or replaced by the PFC which, unlike other intra-alveolar fluids, has the ability to carry out gas exchange.

Improvements in lung function, such as those observed in this study during use of liquid ventilation, may have the potential of improving the relatively high mortality observed in pediatric and adult patients on ECMO. In addition, the time course on extracorporeal support may be shortened, resulting in a reduction in morbidity and cost for ECMO patients of all age groups. Although clinical studies assessing the efficacy of liquid ventilation in patients on ECMO have yet to be performed, the data from this study suggest that pulmonary management with liquid ventilation may improve lung function and, therefore, outcome in the patient with respiratory failure on ECMO.

ACKNOWLEDGEMENTS

This work was funded by the Department of Surgery of the University of Michigan. Perfluorocarbon (perflubron) supplied by the Alliance Pharmaceutical Corporation.

REFERENCES

1. RH Bartlett: Extracorporeal life support for cardiopulmonary failure. *Curr. Probl. Surg.* 27:621-705 (1990).
2. RB Hirschl and RH Bartlett: Extracorporeal membrane oxygenation support in cardiorespiratory failure. *Adv. Surg.* 21:189-211 (1988).
3. TH Shaffer, MR Wolfson and LC Clark, Jr.: State of the art review: Liquid ventilation. *Pediatr. Pulmon.* 14:102-109 (1992).
4. MR Wolfson and TH Shaffer: Liquid ventilation during early development: Theory, physiologic processes and application. *J. Develop. Physiol.* 13:1-12 (1990).
5. PS Richmond, MR Wolfson and TH Shaffer: Lung lavage with oxygenated fluorocarbon improves gas exchange and lung compliance in cats with acute lung injury. *Amer. Rev. Resp. Dis.* 141:A773 (1990).
6. GA Taylor, A Lotze and S Kapur: Diffuse pulmonary opacification in infants undergoing extracorporeal membrane oxygen: Clinical and pathologic correlation. *Radiology* 161:347-350 (1986).
7. AE Schlesinger, JD Cornish and DM Null: Dense pulmonary opacification in neonates treated with extracorporeal membrane oxygenation. *Pediatr. Radiol.* 16:448-451 (1986).
8. RE Kelly, Jr., JD Phillips, RP Foglia, HS Bjerke, LT Barcliff, L Petrus and TR Hall: Pulmonary edema and fluid mobilization as determinants of the duration of ECMO support. *J. Ped. Surg.* 26:1016-1022 (1991).
9. ECMO Registry Report of the Extracorporeal Life Support Organization, Ann Arbor, Michigan, October (1992).
10. PC Pratt, RT Vollmer, JD Shelburne and JD Crapo: Pulmonary morphology in a multihospital collaborative extracorporeal membrane oxygenation project. *A. J. Pathol.* 95:191-214 (1979).
11. M Keszler, FC Ryckman, JV McDonald, Jr., LD Sweet, MG Moront, MJ Boegli, C Cox and CA Leftridge: A prospective, multicenter, randomized study of high versus low positive end-expiratory pressure during extracorporeal membrane oxygenation. *J. Pediatr.* 120:107-113 (1992).
12. JK Stoller and RM Kacmarek: Ventilatory strategies in the management of the adult respiratory distress syndrome. *Clinics in Chest Medicine* 11(4):755-772 (1990).
13. JA Kylstra and WH Schoenfisch: Alveolar surface tension in fluorocarbon-filled lungs. *J. Appl. Physiol.* 33:32-35 (1972).
14. A Lotze, JA Whitsett, LA Kammerman, M Ritter, GA Taylor and BL Short: Surfactant protein A concentrations in tracheal aspirate fluid from infants requiring extracorporeal membrane oxygenation. *J. Pediatr.* 116:435-439 (1990).
15. JH Modell, F Gollan, ST Giammona and D Parker: Effect of fluorocarbon liquid on surface tension properties of pulmonary surfactant. *Chest* 57:263-265 (1970).

NEONATAL ENDOTRACHEAL TUBES: VARIATION IN AIRWAY RESISTANCE WITH DIFFERENT PERFLUORO-CHEMICAL LIQUIDS

W.W. Fox, C. Cox, C. Weis, M.R. Wolfson, T.H. Shaffer
Departments of Physiology and Pediatrics
Temple University School of Medicine
St. Christopher Hospital for Children.
Childrens's Hospital of Philadelphia
Sharpe Foundation of Bryn Mawr Hospital
Philadelphia, PA

ABSTRACT

To evaluate the effect of the physical properties of density and viscosity on airway resistance, three perfluorochemical fluids (PFCs) were used: FC-75, Liquiventtm, and APF-140. Using two different endotracheal tubes (ETT) (3.0mm ID and 4.0mm internal diameter (ID)), the three fluids were studied at steady state flow conditions over a range that approximated peak flow required for liquid ventilation of neonatal lambs (0.005-0.02 l/sec). The slope of airway resistance (Raw)-flow curves and absolute values of Raw for the 3 PFC liquids were higher for the 3.0 ETT compared to the 4.0 ETT. The 3.0 ETT demonstrated resistance changes that were dependent on flow, density and viscosity. The 4.0 ETT showed a resistance-flow relationship that was relatively less dependent on flow, density and viscosity.

INTRODUCTION

Relatively small endotracheal tubes (ETT) are required for gas ventilation of the neonate. It is known that these narrow ETT produce a high Raw with gas ventilation and several modifications have been made to infant ventilators to overcome Raw and decrease work of breathing [1,2].

Recently, newborn and premature animals as well as critically ill infants have been successfully liquid ventilated using PFC liquids [3-7]. These liquids were used because they are inert, have a high respiratory gas solubility and have low surface tension enabling low inflation pressures [8]. Additionally, when ventilating with PFC, low inflation pressures, small tidal

volumes and low breathing frequency are used. This liquid ventilation breathing strategy results in effective physiologic gas exchange and low alveolar pressures [9-11]. To complement this ventilation approach, knowledge of liquid physical properties and their effect on Raw is important in selection of the appropriate PFC for a specific clinical application.

The purpose of this study is to quantitate the combined effects of PFC physical properties and ETT size on Raw.

METHODS

Airway resistance of the ETT was determined with a continuous circuit system, utilizing a variable flow pump (Masterflex Model 7520), open-collection reservoir for unimpeded ETT flow, and fluid/gas capacitor. The capacitor was placed downstream from the pump to dampen pressure variations in the system. Total internal system volume was approximately one liter. Pressure was measured by a pressure transducer (Gould P231D) and the signal was amplified and recorded on a polygraph recorder (Grass Model 7D). Flows were measured at different pump settings by timed collection of fluid. The range of flows were selected to approximate the flow requirements for liquid ventilation of neonatal lambs (.005L/sec to .020 L/sec) [7]. All pressures and flows were measured simultaneously. Two different size neonatal ETT were evaluated (3.0 mm and 4.0 mm ID, length 16cm and 18.5cm: Mallinckrodt Hi-Lo Jet tubes). All ETT had standard adapters (2cm long) with the same ID as the ETT. Three different perfluorochemical liquids were evaluated (@ 25°C).

As shown in Table 1, all three liquids have a density of approximately two times that of saline. Kinematic viscosity of these three fluids increased from FC-75 (3M Corp), to Liquivent™ (Alliance Pharm., Inc), to APF-140 (Air Prod., Inc.).

Airway resistance was calculated by dividing pressure by flow. Pressure-flow and resistance-flow relationships were plotted. As previously described [12], K1 (Y intercept) and K2 (slope) of the Rohrer equation were calculated by using the method of least squares. Reynolds numbers were calculated at the highest flow condition (.02L/sec) using the formula:

$$Re = pVD/u$$

where D=tube diameter, V=mean velocity, p=density, u=viscosity [13].

RESULTS

The relationship between pressure-flow and Raw-flow for both ETT and the three fluids are shown in Fig 1. As expected, pressure and Raw were higher for the 3.0 ETT than the 4.0 ETT for all liquids for similar flow

TABLE I PHYSICAL PROPERTIES OF PFC'S

	FC-75	LiquiVent	APF-140
Density (gm/ml)	1.78	1.93	1.95
Kinematic Visc (cst)	0.82	1.10	2.90
Dynamic Visc (csp)	1.46	2.12	5.66

conditions. Furthermore, it was shown that pressure and R_{aw} in the smaller ETT were more flow dependent.

As shown in Table II, both Rohrer constants (K_1 and K_2) are greater for the 3.0 ETT as compared to the 4.0 ETT for all liquids. For both tubes, K_2 for APF-140 > K_2 for Liquivent > K_2 for FC-75. With the exception of K_1 (FC-75 ; 3.0 ETT), K_1 for APF-140 > K_1 for Liquivent > K_1 for FC-75.

As shown in Table III, computed Reynold's number values varied over the complete range of laminar, transitional, and turbulent flow conditions.

DISCUSSION

The present study characterized the effects of PFC properties and ETT size on the R_{aw} and pressure profiles associated with liquid ventilation. As with gas ventilation, it was found that R_{aw} and pressure were indirectly related to the ETT inner diameter and directly related to flow. It also showed that the physical properties of different PFC liquids have a significant impact upon R_{aw} and pressure. As previously described by the Rohrer equation, resistance, pressure and flow are characterized by the constants K_1 and K_2 where, K_1 is viscosity and geometry dependent and K_2 is density dependent. As show in Table II, the experimental data were consistent with these theoretical predictions. Fluids with the highest dynamic viscosity (K_1) and density (K_2) resulted in the highest R_{aw} and pressure profiles as a function of flow. These in vitro data may have particular relevance towards optimizing in-vivo breathing strategy during liquid ventilation with PFC liquids of different physical properties.

During liquid ventilation there are two major pressures to consider: proximal airway pressure and alveolar pressure. During ventilation using PFC liquids, lower surface tension, low flow rates and the pressure drop along the airway results in lower alveolar pressure despite high airway resistance and proximal airway pressure[10]. Alveolar pressure, seen in the terminal alveoli, is important in determining lung compliance, effecting gas exchange, and preventing barotrauma. As shown in this study, proximal airway pressure, or the driving force required for fluid flow, is therefore dependent upon the physical properties of the breathing medium, dimensions of the ETT, and flow conditions.

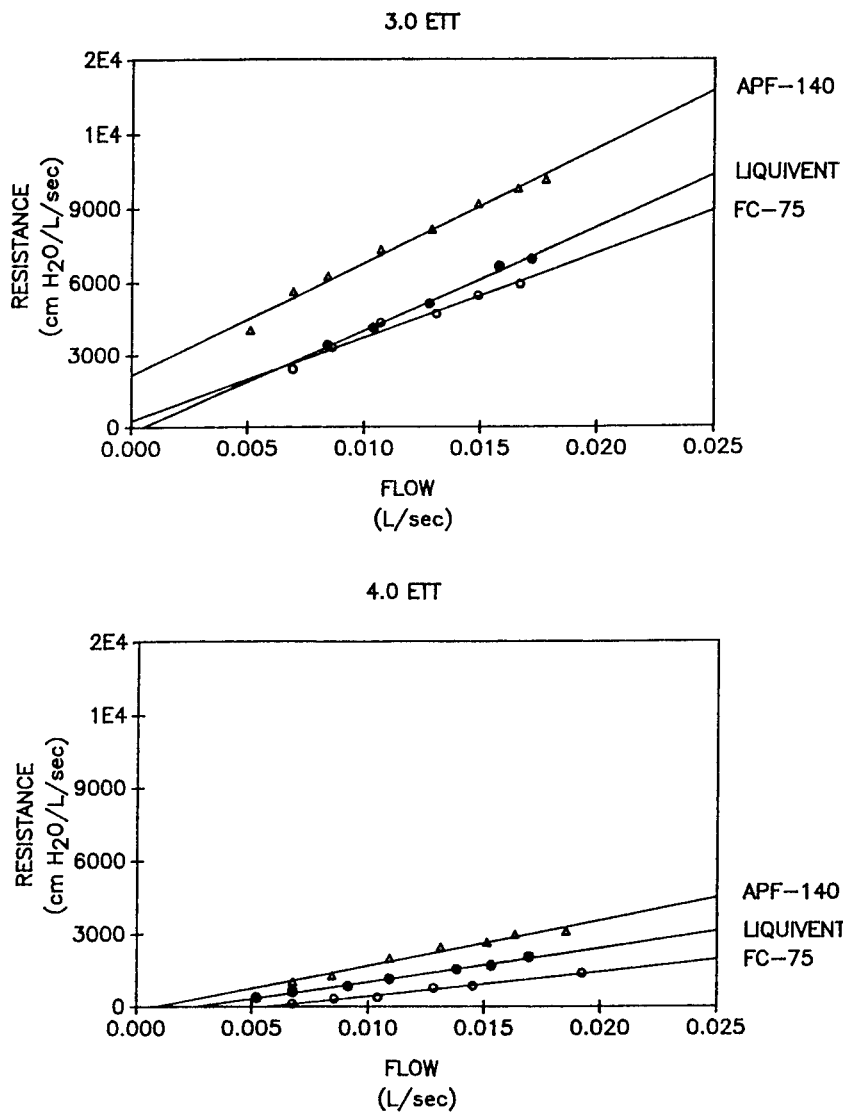

FIGURE I: Resistance and Flow Relationships For Three PFC Fluids
Evaluated with Two Neonatal Endotracheal Tubes

TABLE II : EXPERIMENTAL ROHRER CONSTANTS

ETT	PFC	K1	K2	Corr Coeff
3.0	FC-75	2.64×10^2	3.47×10^5	.98
	LiquiVent	-2.17×10^2	4.23×10^5	.99
	APF-140	2.17×10^3	4.62×10^5	.99
4.0	FC-75	-5.69×10^2	1.01×10^5	.99
	LiquiVent	-3.57×10^2	1.39×10^5	.99
	APF-140	-1.56×10^2	1.86×10^5	.98

TABLE III: REYNOLD'S NUMBERS

ETT	PFC	Reynold's Number
3.0	FC-75	5183
	LiquiVent	3863
	APF-140	1465
4.0	FC-75	3887
	LiquiVent	2900
	APF-140	1099

As previously mentioned, K1 is dependent on tube geometry as well as viscosity. In this regard, K1 is directly related to $[8l/Dr^4] \times u$. As noted for the small 3.0 ETT, the K1 appeared to be relatively more dependent on radius rather than viscosity effects. Therefore, the radius difference between the two ETTs had a greater overall effect on airway resistance and pressure than the difference in fluid viscosity.

In summary, there are several different factors to consider when selecting a PFC liquid for mechanical ventilation, such as gas solubilities, diffusion coefficients, surface tension, vapor pressure, density and viscosity. After determining the ETT size, and PFC liquid needed to ventilate a neonatal animal, the alveolar pressures may be minimized by knowing specifically how the density and viscosity of each PFC liquid will effect the Raw of a certain size ETT.

ACKNOWLEDGEMENTS

This work was supported in part by the National Institutes of Health - HLBI 32031 and the American Heart Association, Alliance Pharmaceutical Corp, Air Products and Chemicals, Inc. Miteni, s.r.l., and 3M Corporation.

REFERENCES

1. A Greenough, J Pool: Arch Dis Child. 63:394-7 (1988).
2. WW Fox, VK Bhutani, S Abbasi, AR Spitzer: Pediatr. Res. 31(4): 307A (1992).
3. TH Shaffer, MR Wolfson, LC Clark: Pediatr. Pulmonol. 14:102 (1992).
4. MR Wolfson, N Tran, VK Bhutani, TH Shaffer: J. Appl. Physiol. 65:1436(1988).
5. SE Curtis, BP Fuhrman, DF Howland: J Appl Physiol 68(6):2322(1990).
6. JS Greenspan, MR Wolfson, SD Rubenstein , TH Shaffer: Lancet Nov 4, (1989).
7. JS Greenspan, MR Wolfson, SD Rubenstein, TH Shaffer: J. Pediatr 117:106(1990).
8. JG Riess, M LeBlanc: Pure Appl Chem. 54:2383(1982).
9. PA Koen, MR Wolfson, TH Shaffer: Pediatr. Res. 24: 291(1988).
10. TH Shaffer, N Tran, VK Bhutani, EM Sivieri : Pediatr. Res. 17: 680(1983).
11. MR Wolfson, JS Greenspan, KS Deoras, SD Rubenstein, TH Shaffer: J Appl Physiol 72:1024 (1992).
12. PE Wright, JJ Marini, GR Bernard: Am Rev Dis 140: 10-16 (1989).
13. R Grange: Fluid Mechanics. Philadelphia: Holt Rinehart, Winston. (1985).

FLUORINATED PHOSPHOLIPID-BASED VESICLES AS POTENTIAL DRUG
CARRIERS : ENCAPSULATION/SUSTAINING OF DRUGS AND STABILITY
IN HUMAN SERUM

F. Frezard, C. Santaella, P. Vierling, J. G. Riess

Unité de Chimie Moléculaire, associée au Centre National de la Recherche
Scientifique, Université de Nice-Sophia Antipolis, 06108 Nice Cédex 02, France.

ABSTRACT : The release of entrapped 5(6)-carboxyfluorescein from fluorinated vesicles in a buffer or in human serum is considerably less than that from hydrogenated liposomes. The presence of a fluorinated core inside the liposomal membrane definitely reduces its permeability. In some cases, the stability of liposomes made from fluorinated phospholipids alone is better than that of egg phosphatidylcholine cholesterol 1/1 vesicles, which are among the least permeable and most stable hydrogenated liposomes.

INTRODUCTION

Vesicles made of phospholipids (or liposomes) are closed uni- or multilayer shells which separate an internal aqueous compartment from the bulk solution. Their ability to encapsulate a wide variety of solutes, including hemoglobin (encapsulation of hemoglobin might prevent its leakage from vascular spaces and subsequent interaction with the vasomediator, nitric oxide), has stimulated intensive efforts to develop drug carrier and delivery systems [1]. Several liposomal drug formulations are presently in clinical trials. However, additional research is needed to improve our ability to control and manipulate the liposomes' long-term shelf-stability, stability in biological environments (stability is defined here as the extent to which the carrier retains its drug content), in vivo recognition, intravascular persistence, biodistribution and reactions triggered in the organism.

The elaboration of a stable membrane which allows the encapsulation and retention of a variety of drugs is a challenging objective. It is achieved to some extent by increasing the rigidity of the membrane either by including cholesterol (CH) into the membrane or by using phospholipids which tend to self-organize into a rigid gel lamellar phase [2]. Such liposomal formulations have, however, limited potential : (i) cholesterol is unsuitable for certain pathologies ; (ii) a hydrocarbon membrane constitutes only a tenuous barrier, especially for sustaining water-soluble lipophilic drugs ; (iii) vesicles with rigid membranes display slow drug release but do not allow for modular drug release.

With the aim of broadening the potential of liposomes as drug carriers or hemoglobin containers, we have investigated the possibility of endowing the liposomal membrane with some of the unique properties of fluorocarbons. Fluorocarbons are both highly hydrophobic and lipophobic phases. The creation of a more hydrophobic membrane with an internal lipophobic barrier was expected to reduce its permeability for certain drugs and modify its interactions with serum constituents [3].

We have already shown that perfluoroalkylated phospholipids (Figure 2) form highly stable liposomes (*F*-liposomes) as a result of enhanced hydrophobic interactions due to the presence of the perfluoroalkyl tails [4]. The thickness of the lipophilic and lipophobic zones and their physical properties can be modulated by adjusting the length of the hydrocarbon and fluorocarbon segments i.e. the value of *m* and *n* respectively.

We report herein our investigations on the ability of liposomes formulated with fluorinated phospholipids to retain an entrapped drug model, 5(6)-carboxyfluorescein (CF), when these liposomes are incubated in a buffer or in human serum.

MATERIALS AND METHODS

Small unilamellar vesicles, SUVs, were prepared by sonication of the appropriate phospholipids (25-50 mM) in a 100 mM 5(6)-carboxyfluorescein (CF) solution. They were stored for 12 hours before the non-entrapped dye was separated on a buffer equilibrated gel (Sephadex G-50). The dispersions consisted of 30-60 nm vesicles (95%) as measured by photon correlation spectroscopy (Coulter model N4 MD). Fluorescence experiments were performed with a Perkin Elmer LS50B spectrometer. The release of the entrapped probe, either in human

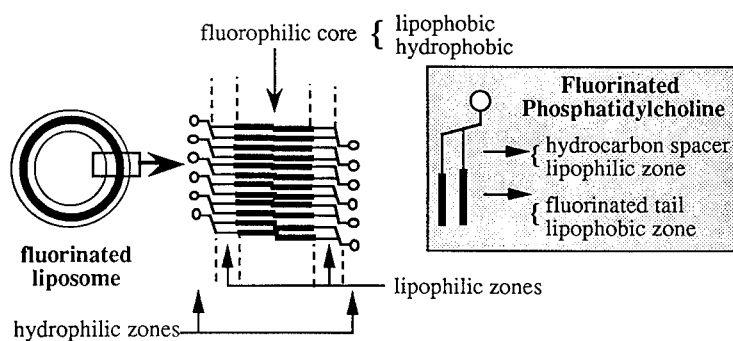

FIGURE 1 : Fluorinated bilayer core concept

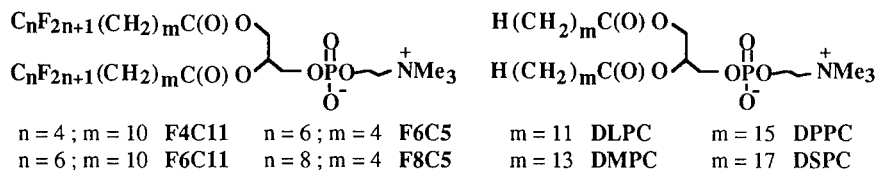

FIGURE 2 : Nomenclature of the fluorinated and hydrogenated phospholipids used

serum or in a saline buffer (pH 7.5), was followed by continuous monitoring of the fluorescence signal (F) increase (excitation 480 nm, emission 520 nm). The maximal fluorescence, F_{max} , was determined after lysis of the liposomes [5]. When possible, the CF leakage half time $t_{1/2}$ (time at which 50% of CF is still encapsulated) was determined by plotting the fraction of encapsulated dye [= $(F_{max} - F)/F_{max}$] versus time. When the kinetic was too slow to allow the direct determination of $t_{1/2}$, the linear portion of the log of entrapped dye fraction versus time was used. This slope (K) is related to $t_{1/2}$ by the relation : $t_{1/2} = Ln(2)/K$. Each experiment was performed in triplicate.

RESULTS

Figures 3a and 3b display the time course release of CF from SUVs prepared from the different phospholipids investigated and incubated at 37°C in a 0.15 M NaCl / 20 mM Hepes buffer or in human serum.

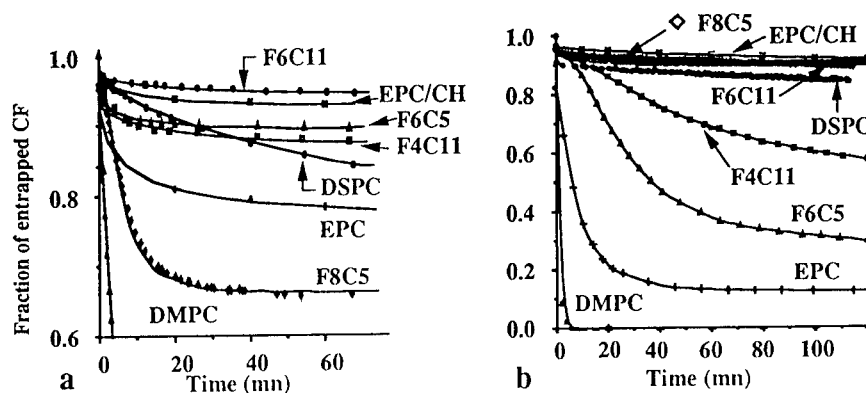

FIGURE 3 : Release of CF from SUVs in (a) buffer or (b) human serum

The leakage half-times, $t_{1/2}$, of CF from the vesicles are summarized in Table I. The CF leakage from DLPC and DMPC liposomes, in buffer and serum respectively, was too fast to allow the determination of $t_{1/2}$.

DISCUSSION

The main objectives of this study were to evaluate the impact of fluorinated tails on the permeability of phosphatidylcholine-based liposomes and on their stability with respect to drug leakage in order to explore their potential as drug carriers. We have therefore examined the ability of fluorinated vesicles to retain encapsulated CF when the vesicles are incubated either in a biological buffer or in human serum at 37°C. CF, which is often utilized to study non-permeable membranes, was chosen as a water-soluble drug model.

F-Liposome stability in a physiological buffer. Our results show that the vesicles formulated with the perfluoroalkylated phosphatidylcholines, when incubated in a physiological buffer at 37°C, retain their entrapped content significantly more than any of their hydrogenated counterparts, including EPC/CH liposomes which are among the most efficient liposome formulations known so far. The higher stability of the fluorinated vesicles with respect to CF release is illustrated by their CF leakage half-times, $t_{1/2}$, which are in the 27 to 66 h range while the $t_{1/2}$ of the hydrogenated ones are in the 0.3 to 28 h range (Table I). These results demonstrate that vesicles made from fluorinated phospholipids exhibit much

TABLE I : CF leakage half times, $t_{1/2}$, from SUVs at 37°C in a 0.15 M NaCl / 20 mM Hepes buffer or in human serum.

Compound	F6C5	F8C5	F4C11	F6C11	DMPC	DSPC	EPC ^b	EPC/CH ^c
$t_{1/2}$ (SD, h) ^a in buffer	81 (4)	28 (8)	81 (8)	62 (3)	0.3 (0.1)	9.6 (2)	13.0 (0.8)	33 (8)
$t_{1/2}$ (SD, h) ^a in serum	0.66 (0.06)	25 (3)	3.6 (0.1)	166 (20)	-	19.3 (0.6)	0.12 (0.02)	35.2 (0.8)
$t_{1/2}$ (serum)/ $t_{1/2}$ (buffer)	0.008	1	0.045	2.7	-	2	0.009	1.06

a) SD : standard deviation ; b) EPC : egg phosphatidylcholines ; c) 1/1 (M).

lower membrane permeability than vesicles made from hydrogenated analogs, regardless of the length of the hydrophobic chains and of the physical state, gel or fluid, of the liposomal membrane. It is particularly noteworthy that F6C5, which possesses the shortest chains (11 carbon atoms) among the fluorinated phospholipids investigated, is considerably less permeable (at least 15,000 times) than DLPC liposomes (12 C). It is even 6 times less permeable than DSPC (18 C) which, among the hydrogenated membranes, exhibits the lowest permeability. The membrane permeability of F6C5 is as low as that of F4C11 and F6C11 which possess even longer hydrophobic chains.

It has been shown for the hydrogenated phospholipids that reducing the length of their hydrophobic chains results in an increase in membrane permeability [2]. Our results are in apparent contradiction with this model. Diffusion across the membrane does, indeed, remain unmodified when going from F4C11 to F6C5, (hence when shortening the overall chain length) but this occurs because the fluorinated tail length is increased. This result merely indicates that a C₆F₁₃ tail produces a stronger impermeabilization effect than a C₄F₉ one. It was therefore expected that a C₈F₁₇ chain would produce an even stronger impermeabilization effect. We found, on the contrary, that F8C5 vesicles, exhibit the lowest CF leakage $t_{1/2}$ value of the the fluorinated vesicles. As shown elsewhere, this compound forms a lamellar phase which, at 37°C, is in a semi-gel semi-fluid state [6]. When the vesicles are incubated at 37°C, the fluorinated core is in a fluid state while the hydrocarbon spacers are still rigid and strained. This is likely to generate packing defects which may account for the higher permeability of the F8C5 membrane.

F-Liposome stability in human serum. Serum is among the biological fluids known to induce the strongest destabilization effects on liposomes [2]. Our results show that serum destabilizes the liposomes whose membranes are in the fluid state at 37°C. This is the case for F6C5, F4C11 [6], DMPC, and EPC : the CF leakage is indeed considerably increased when going from buffer to serum as shown in table I by the ratios of serum to buffer $t_{1/2}$, which are much lower than 1. The CF release from F6C5 and F4C11 vesicles in serum remains, however, considerably lower than that from DMPC and EPC vesicles. It also appears that the CF leakage from fluorinated vesicles is less affected by the serum components, as shown by the higher $t_{1/2}$ ratio of F4C11, when compared to that of EPC. This most probably indicates that the fluorinated core inside the liposomal membrane protects the vesicles against the destabilization effects of blood serum.

On the other hand, liposomes whose membranes are in the gel state at 37°C, i.e. those of F6C11 [6] and DSPC, are found to be more stable in serum than in the physiological buffer, as expressed by $t_{1/2}$ ratios larger than 1. The most stable vesicles are those formulated with the fluorinated phospholipid F6C11. The CF leakage from these vesicles is almost 4.7 times lower than that from the EPC/CH liposomes, while it is only about 2 times lower in buffer. This indicates that in the presence of serum, the fluorinated core inside the membrane improves the retention of the dye even when the membrane is in the gel state. It is also noteworthy that the $t_{1/2}$ values of F8C5 vesicles are similar in serum and in buffer. Furthermore, these vesicles were found to be much less leaky in serum than the F6C5 and F4C11 vesicles. This most likely arises from the fact that the F8C5 is in a semi-gel state at 37°C [6]. It should also be mentioned that F8C5 and DSPC vesicles show comparable stability.

REFERENCES

- [1] Gregoriadis G. *Liposomes as Drug Carriers : Recent Trends and Progress*, Wiley, Chichester (1988).
- [2] Senior J., Gregoriadis G., *Life Sciences* , **30**, 2123-2136 (1982)
- [3] Riess J.G., *Colloids & Surfaces A*, **84**, 33-48 (1994)
- [4] Santaella C., Vierling P., Riess J.G., *Angew. Chem. Int. Ed.*, **30**, 567-568 (1991)
- [5] Lelkes P.I., Tandeter H.B., *Biochim. Biophys. Acta*, **716**, 410-419 (1982).
- [6] Riess J.G., Santaella C., Vierling P. ; *Proceed. XXIIe CED Meeting on Surfactants, Palma de Mallorca, Comité Espagnol Detergencia, Tensioactivos y Afines*, Ed. Barcelone, p. 157-171, (1991).

**UTILITY OF A PERFLUORO-CHEMICAL LIQUID FOR
PULMONARY DIAGNOSTIC IMAGING**

M.R. Wolfson, R.G. Stern, N. Kechner,
K.M. Sekins^{*}, and T.H. Shaffer

Temple University School of Medicine
Departments of Physiology, Pediatrics, and Diagnostic Imaging
St. Christophers Hospital for Children
Philadelphia, PA, USA

^{*} Alliance Pharmaceutical Corp. San Diego CA

ABSTRACT

The use of neat perfluorochemical liquid (PFC) as an alternative respiratory medium has gained increasing attention for assessment and treatment of the immature or injured lung. *In vitro* and *in vivo* plain film and computed tomographic (CT) studies were performed on small and large animals to evaluate the use of perfluorooctylbromide (perflubron) as a bronchographic contrast agent and to quantitate the distribution and elimination of this fluid from the lung following total liquid ventilation or during gas breathing after tracheal instillation of small quantities of this liquid. The results demonstrate the utility of a highly radiopaque PFC liquid in combination with diagnostic imaging techniques to visualize small airways anatomy, identify regional and gravity dependent differences in distribution/elimination of the fluid, ventilation, and track PFC liquid following therapeutic application.

INTRODUCTION

Perfluorochemical (PFC) liquids have gained increasing attention for assessment and management of restrictive pulmonary dysfunction (see Shaffer et. al. in these proceedings). Because of low surface tension and high respiratory gas solubility, PFC liquids support homogenous insufflation of the lung at lower alveolar pressures, pulmonary gas exchange, improved distribution of biological agents and ventilation/perfusion match-

ing relative to gas ventilation of the immature or injured lung [1-16]. These fluids are inert, non-biotransformable, and vaporized through the lung; perflubron (perfluorooctyl bromide) is also radiopaque [17]. As such, perflubron provides a potential adjunct in diagnostic imaging to evaluate pulmonary structure-function relationships without intrinsic problems related to existing contrast agents [18] and may be tracked during total liquid ventilation (LV), gas breathing after tracheal instillation, or following other therapeutic applications. Unique characteristics such as the presence of bromine atoms, molar percentage of fluorine, absence of hydrogen atoms, low sound speed and acoustic attenuation distinguish the relative utility of PFC liquids in conventional x-ray, computed tomography (CT), ^{19}F magnetic resonance, and ultrasound imaging techniques [19- 25]. In vitro and in vivo studies were performed in animals to evaluate the use of a highly radiopaque neat PFC liquid, perflubron, as a high resolution computed tomographic (HRCT) bronchographic contrast agent and to qualitatively and quantitatively evaluate the distribution and sequential elimination of this fluid from the lung by multi-modal imaging techniques.

METHODS AND MATERIALS

Perfluorochemical Liquid: Neat perflubron (perfluorooctyl bromide: LiquiVent tm; Alliance Pharm. Corp.) was utilized in all studies.

Imaging: CT images were obtained on a GE 9800 HiLight Advantage CT scanner using 1.5 mm collimation, high-spatial-frequency reconstruction algorithm, 2 sec scan time, and kVp/Ma of 120/170. Control images were filmed at windows of 900 and levels of -550; extended window settings were used for the PFC contrast scans. A minimum of 10 sections were obtained. Image analysis and densitometry algorithms based on tissue thickness, pixel dimensions and respective Hounsfield numbers were used to quantitate gas, PFC, and soft tissue volumes of representative sections for sequential studies. Conventional CT scanning used 10 mm collimation and lung window settings. Conventional radiographs were obtained with General Electric MS-850 Fluoricon 300 at settings of 100 Ma, 70 kV, .005 sec.

In Vitro Study: A 3 day old, 3 kg mechanically gas ventilated neonatal lamb was sacrificed with sodium pentobarbital overdose and KCL. The lungs and heart were removed en bloc, floated in a saline bath, and mechanical gas ventilation was continued. HRCT imaging was performed at end inspiration (30 cm H_2O) before and after intratracheal instillation of the PFC liquid (10 ml/kg). The lungs were inverted and rotated to promote liquid distribution.

In Vivo Studies: *Study 1:* A 125 day gestation preterm lamb was delivered by cesarean section and mechanically gas ventilated for 4 hrs. Exogenous surfactant was administered at 1 hr of life and a bolus of PFC liquid (30 ml/kg) was delivered at 2 hrs of life. The ventilatory profile was changed based on arterial blood chemistry and pulmonary mechanics measurements and optimized to support arterial oxygenation and carbon dioxide elimination. Ventilatory pressures were limited to a maximum of 35 cm H₂O on inspiratory and 5 cmH₂O positive end expiratory pressure; the animal was rotated every 15-30 minutes. Plain film imaging was performed at 4 hrs of life at end inspiratory pressure. *Study 2:* An adult, 425 gm rat was anesthetized (50 mg/kg IP sodium pentobarbital) and a tracheal cannula was secured through a tracheotomy following local anesthesia (4 mg/kg; .50% lidocaine). The rat was mechanically gas ventilated to maintain physiologic gas exchange and acid-base conditions. HRCT imaging was performed during mechanical gas ventilation at 1 and 30 min following bolus tracheal instillation (30 ml/kg) of the PFC liquid. The animal was rotated and gentle thoracic manipulation was used to assist liquid distribution. *Study 3:* A 15 kg, 4 wk old weanling sheep was anesthetized (IP: 30 mg/kg sodium pentobarbital) and a modified 35 Fr double balloon-cuffed bifurcated bronchocatheter was secured through a tracheotomy under local anesthesia (4 mg/kg, 0.50% lidocaine). The proximal lumen was positioned to isolate the right cranial apical (RCA) lobe as spontaneous breathing continued. Isolation was assessed by pressure maintenance and independent flow profiles measured by pneumotachography. The RCA lobe was insufflated with 90 ml of oxygenated (FiO₂ = 1) and warmed (38°C) PFC liquid. Lobar LV (tidal volume = 90 ml, frequency = 5 br/min) was maintained for a total of 64 minutes. During this time the inspired liquid temperature was ramped to a maximum of 43.5°C for 30 mins, and returned to body temperature for the duration of the lobar liquid ventilation. Liquid above the initially instilled volume was passively drained; the lobe was then mechanically gas ventilated (inspiratory pressure = 20 cmH₂O; end-expiratory pressure = 5 cmH₂O; frequency = 30 br/min) for 10 mins. The trachea and skin were closed as the animal was extubated and supported with 50% oxygen delivered by nasal cone for 20 mins. Post-surgical management included systemic and local antibiotics, and analgesics; aggressive chest physical therapy with repositioning was performed every 30 mins until full quadruped mobility was regained (by 5 hrs). Sequential plain films and CT imaging was performed.

RESULTS

In Vitro Study: HRCT images before and after tracheal instillation of perflubron in the neonatal lamb lung are shown in fig. 1. In comparison to .pa

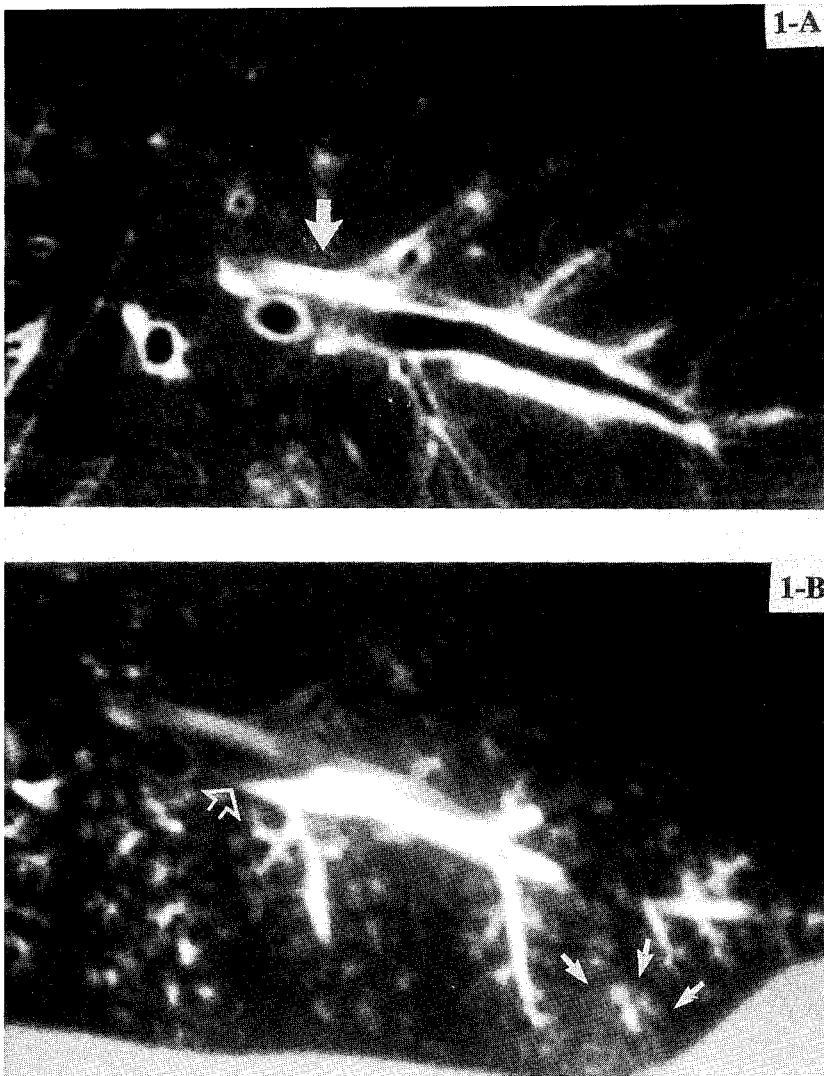

FIGURE 1: HRCT image of isolated *in vitro* neonatal lamb lung before (A) and after (B) tracheal instillation of 10 ml/kg of perflubron. Short thick arrow: thickened interstitium around central bronchus; opened short arrow: air:fluid level, note lack of bronchial wall coating in unopacified portion; short small arrows: opacified pulmonary lobule with entral high density representing perflubron filled centrilobular brnchial. Diffuse punctate and linear high densities represent multiple small airways at varying obliquity with the plane of imaging.

control images, images of central bronchi following PFC instillation reveal air-contrast levels without evidence of contrast-coating of unopacified or partially filled bronchi. PFC filling and distension of centrilobar bronchioles defined branching tubular structures leading to pulmonary lobules, branches of centrilobular bronchioli, and margins of subtended lobules were noted by ground-glass opacification of the air spaces.

In Vivo Studies: *Study 1:* Plain film radiographs of the preterm at 4 hrs of age are shown in figure 2. The anterior-posterior supine view reveals generalized opacification of the lung with diffuse air bronchograms identifying much of the central bronchial tree. The cross table supine lateral view shows greater density posteriorly and peripherally, minimal airway opacification, and evidence of a right-sided anterior pneumothorax. *Study 2:* HRCT images of the mechanically gas ventilated rat sequentially following instillation of the PFC liquid are shown in figure 3. Immediately following instillation, images demonstrate diffuse patchy consolidation with evidence of PFC liquid and soft tissue density. There was combined peripheral and gravity dependent distribution of the liquid with relative sparing around the central airways and no clear evidence of the PFC liquid in the main bronchi. The most prominent PFC densities appeared posteriorly, laterally, and adjacent to the pleural surfaces. By 30 mins there was evidence of partial clearing of the PFC liquid from all lobes of the lung; clearing was more prominently seen centrally and anteriorly as compared to the periphery. The densitometry histograms (not shown for brevity) show a left and downward shift corresponding to decreasing perflubron and increasing gas volume. Quantitation by densitometry indicated a 45% overall density decrease in a selected slice volume by approximately 30 mins following instillation of PFC. *Study 3:* Sequential plain film radiographs and CT images of the weanling sheep following lobar LV are shown in figure 4. Day 1 plain films revealed dense consolidation of the RCA lobe with dependent predominance and outlining of the visceral pleural surface. By day 2, there was significant clearing of the apical segment with residual dense consolidation of the caudal segment of this lobe. The apical segment continued to clear and persistent radiodensity was noted in the caudal segment by 49 days. CT images on day 14 showed clearly outlined fissures demarcating the RCA from the cardiac lobe at the most inferior caudal aspect of the RCA lobe. The apical cranial bronchus was well visualized departing from the main trachea leading directly into the largest area of density (image not shown for brevity). Consolidation of the caudal segment of the RCA lobe was quantitated and found to be consistent with high density equivalent to the PFC in Houndsfield units. No significant interval change in appearance was noted on CT images between days 14 and 37.

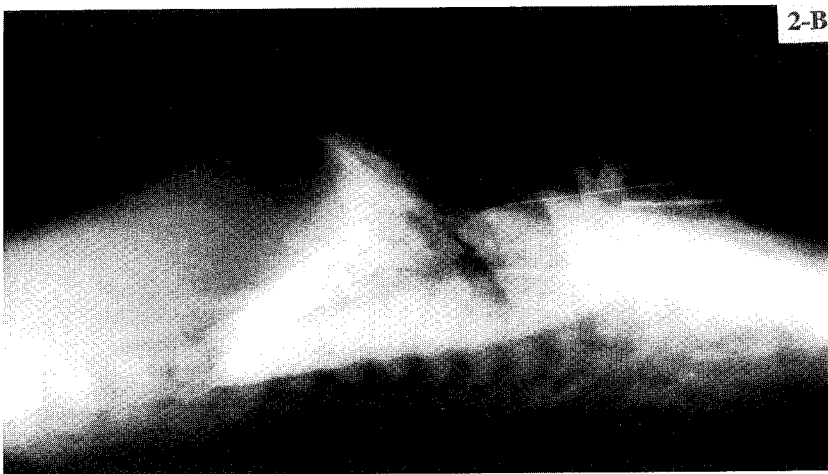
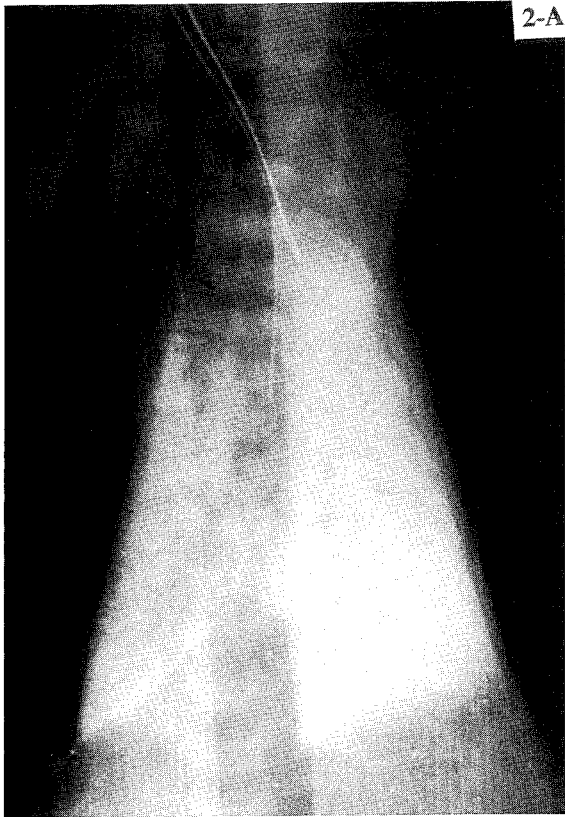

FIGURE 2: Plain film anterior-posterior (A) and cross table lateral (B) in vivo radiographs of a supine preterm lamb.

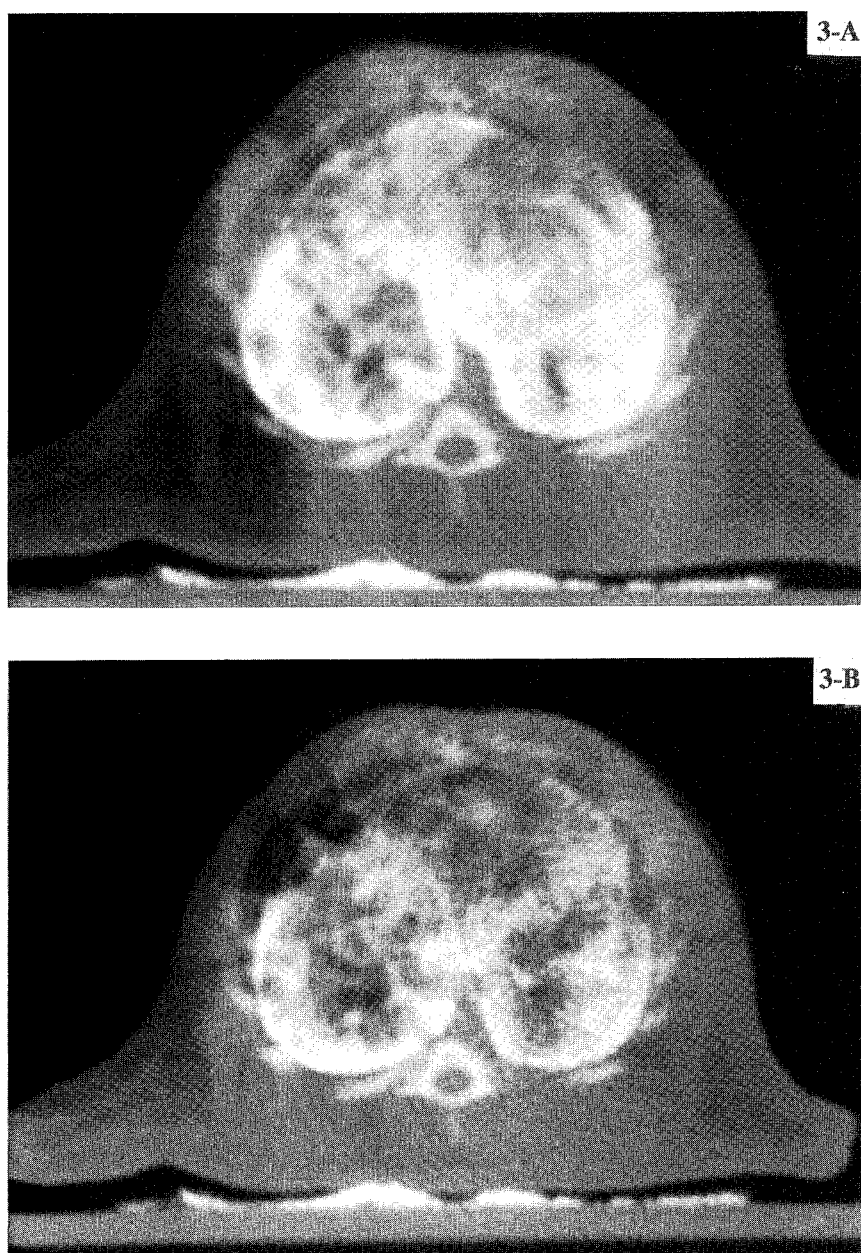

FIGURE 3: Sequential *in vivo* HRCT images of the same section of rat lung at 1 (*A*) and 30 mins (*B*) following tracheal instillation of 30 ml/kg perflubron.

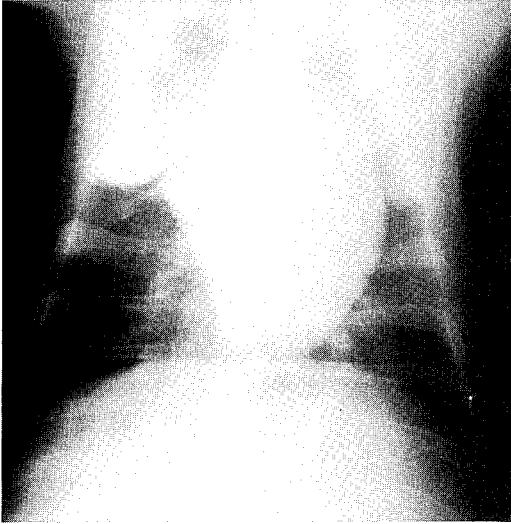

FIGURE 4: Sequential plain film radiographs (day 6 [**A**] and 49 [**B**]) and CT image (day 14; **C**) of the weanling lamb following liquid ventilation of the right cranial apical lobe.

DISCUSSION

While CT and HRCT have advanced diagnosis of airway abnormalities, differentiation of small airway disease is still limited. Radiologic insight to this disease may be gained indirectly via an enlarged centrilobular dot; however, this finding is nonspecific [26]. In this study, the combination of HRCT and tracheal instillation of perflubron allowed direct visualization of the centrilobular bronchioles and beyond in the lung of a neonatal lamb. Access to these structures is presumably related to the low surface tension and density of the fluid enabling position-related filling of airways and alveolar spaces. Instillation of small volumes prevented overflow and obscuring of bronchiolar anatomy. As there was no evidence of the neat liquid coating airways, definition of airways extending beyond the centrilobar bronchi was related to filling. Resolution of bronchopulmonary architecture was effected by respiratory frequency as evidenced by the relatively finer delineation of segmental airways in the slower breathing weanling sheep as

4-B



4-C



FIGURE 4: Continued

compared to the rat; more refined CT technology is needed to extend imaging precision across respiratory patterns. Previous plain film radiography studies following tracheal instillation of neat and emulsified perflubron have reported radiopacification of the alveolar compartment by neat perflubron and of tracheobronchial tree components by emulsified perflubron [19]. Whereas tracheally instilled perflubron emulsions may coat the airway and provide enhanced radiodensity for plain film techniques, dependence on mucociliary mechanisms for clearance may be problematic for patients with pre-existing pulmonary dysfunction. In contrast, because perflubron is cleared primarily by vaporization, the present findings suggest that HRCT imaging with tracheally instilled neat perflubron provides a modality to evaluate small airways without additional pulmonary compromise.

We have also demonstrated the need for multi-modal imaging techniques to define the anatomical distribution and elimination patterns of tracheally instilled perflubron. Comparison of plain film views differentiated an apparent relative homogeneous to a largely peripheral and gravity-dependent distribution pattern. CT images expanded this profile to identify migration of fluid along the pleural margins and related the distribution to segmental bronchial anatomy. Plain film radiography is helpful in qualitatively describing elimination of neat perflubron from the lung but combined techniques are required to quantitatively assess regional retention and elimination. Whereas plain films indicated comparatively little clearing of neat perflubron from the periphery, sequential HRCT images identified central as well as peripheral clearance patterns. CT imaging enabled quantitative assessment of the clearance pattern through sequential gas and perflubron volume calculations. Progressively smaller areas of radiodensity on sequential plain film studies provided qualitative assessment of neat perflubron clearing from an isolated lobe; however, CT imaging was required to identify specific areas of clearance, quantitate changes in gas and perflubron volume, and relate these areas to segmental anatomy.

These studies extend the potential clinical utility of neat perflubron liquid in the lung. Perflubron enhanced HRCT provides a relatively non-invasive method of assessing regional ventilation by simultaneous delineation of structural integrity out to the alveolar compartments and quantitation of respiratory media (ie. gas and perflubron). Other aspects of perfluorochemicals make it a desirable medium for MRI oxygen mapping in the lung [21]. The combination of HRCT for structural analysis and MRI for metabolic tracking offers promise for non-invasive assessment of regional ventilation and perfusion in the lung, pulmonary structure-function relationships for the diagnosis and treatment of pulmonary dysfunction.

ACKNOWLEDGEMENTS

The authors gratefully acknowledge Robert Roache, Joyce Forge, John Hoffman, and Mark Wyzgala for their assistance in these studies and Alliance Pharmaceutical Corp. for the supply of LiquiVenttm. This work for supported in part by National Institutes of Health HLBI 32031, R29HD26341, CA 48611.

REFERENCES

1. LC Clark, F Gollan: Science 152: 1755 (1966).
2. TH Shaffer, SD Rubenstein, GD Moskowitz, M Delivoria-Papadopoulos: *Pediatr Res* 10:227 (1976).
3. EP Wessler, R Iltis, LC Clark: *J Fluor Chem* 9:137 (1977).
4. TH Shaffer, CA Lowe, Vk Bhutani, PR Douglas: *Pediatr. Res.* 19:49 (1984).
5. V Puchetti, GF Maffezzoli, F Costa, E Montresor, M Sgro, F Carolo: Abstracts of the 4th World Congress for Bronchology p. 115 (1984)
6. MR Wolfson, N Tran, VK Bhutani, TH Shaffer: *J. Appl. Physiol.* 65:1436 (1988).
7. MR Wolfson, TH Shaffer: *J Develop Physiol* 13:1 (1990)
8. MR Wolfson, TH Shaffer: *The FASEB J.* 4:1105 (1990).
9. MR Wolfson, JS Greenspan, TH Shaffer: *Pediatr Res* 29(4): 336 (1991).
10. MA Zelinka, MR Wolfson, S Calligaro, SD Rubenstein, JS Greenspan, TH Shaffer: *Pediatr Res.* 29: 290 (1991).
11. PS Richman, MR Wolfson TH Shaffer, SG Kelsen: *Amer Rev Resp Dis* 141:773 (1990).
12. JS Greenspan, MR Wolfson, SD Rubenstein, TH Shaffer: *J. Pediatr* 117: 106 (1990).
13. B Lachmann, AS Tutuncu, JAH Bos, NS Faithfull: *Proceedings from Inter Soc for Oxygen Transport to Tissues, Willenstand, Curacao* (1991).
14. TH Shaffer, MR Wolfson, LC Clark: *Pediatr. Pulmonol.* 14:102 (1992)
15. MR Wolfson, JS Greenspan, KS Deoras, SD Rubenstein, TH Shaffer: *J. Appl. Physiol.* 72(3):1024 (1992).
16. PS Richman, MR Wolfson, TH Shaffer: *Crit Care Med* xxx (1993)
17. JG Riess: In: Blood substitutes and oxygen carriers Chang TMS(ed), M. Decker, N.Y., 24-43 (1993).
18. AJ Christoforidis, SW Nelso, PC Pratt: *Amer Rev Respir Dis* :249 (1967)
19. DM Long , MS Liu, Szanto, DP Alrenga, MM Patel, MV Rios, LM Nyhus: *Radiology* 105: 323 (1972).
20. RF Mattrey, DM Long, F Multer, RM Mitten, CB Higgins. *Radiology*, 145:755, (1982).

21. SR Thomas, LC Clark, JL Ackerman, RG Pratt, RE Hoffman, LJ Busse, RA Kinsey, RC Samaratunga: *J. Comput Assist Tomogr* 10(1):1 (1986).
22. RF Mattrey, JJ Brown, RE Shelton, MT Ogino, KK Johnson, RM Mitten: *Invest Radiol*, 26: 792 (1991).
23. KM Sekins, GW Keilman, TH Shaffer, MR Wolfson, MC Ziskin: *Radiation Res Soc* (1990).
24. RG Stern, MR Wolfson, JF McClurkin, JA Forge, TH Shaffer: *J. Thoracic Imaging* (In Press).
25. DA Lynch, RC Brasch, KA Hardy, RW Webb: *Radiology* 176:243 (1990).

**NOVEL INJECTABLE FLUORINATED CONTRAST AGENTS
WITH ENHANCED RADIOPACITY.**

V. Sanchez¹, L. Zarif¹, J. Greiner¹, J.G. Riess¹, S. Cippolini², J.N. Bruneton²

*¹Unité de Chimie Moléculaire, associée au CNRS, Université de Nice-Sophia
Antipolis, Parc Valrose, 06108 Nice cedex 02, France.*

²Centre Antoine Lacassagne, 36 voie Romaine 06054 Nice cedex, France.

ABSTRACT

Novel emulsions containing iodinated fluorinated radiopaque (IFR) molecules were prepared and evaluated as injectable contrast agents with prolonged intravascular persistence. Various stable IFR/egg yolk phospholipid emulsions were produced, heat-sterilized, and tested as to their radiopacity, shelf-stability and *in vivo* tolerance. No significant change in mean particle sizes was observed over a 3-month storage period at 40°C. Intravenous injection of an emulsion of a 0.39 g/kg bw dose of a typical IFR, C₆F₁₃CH=CIC₆H₁₃ (F6H6IE) in rabbits led to high contrast in the liver and spleen. The same radiopacity of the liver was achieved with 7 times less IFR than perfluorooctyl bromide. Histological examination after 24 h, and blood analysis after 24, 48 h and 7 days, demonstrated normal functioning of the liver, even when high concentrations of IFR were present. The neat IFR was tolerated *i.p.* in mice at a 45 g/kg bw dose. Emulsified IFR was tolerated in rats and mice *i.v.* at a 8 g/kg bw dose. The iodinated fluorinated molecule tested appears promising for the formulation of new contrast agents for diagnosis.

INTRODUCTION

The contrast agents generally used with diagnostic modalities such as conventional X-ray or computed X-ray tomography are either hydrosoluble or lipidic. Hydrosoluble agents, which are mostly iodinated compounds of high or low osmolarity, have a short intravenous persistence due to their rapid diffusion in the tissues. The time available for examination is therefore short, and repeated injections are often necessary [1,2]. Moreover, water-soluble iodinated contrast agents are not adapted to every type of diagnosis; their elimination by the kidneys, for example, precludes their use for hepatic diagnosis. Side effects such as anaphylactic reactions or cardiovascular complications have been observed with such agents [3, 4].

Lipidic iodinated contrast agents such as Lipiodol®[5] or EOE-13 [6,7] have been developed specifically for imaging the hepatic system, but they present stability problems. The lipiodol emulsion, for instance, must be prepared immediately before use and cannot be injected intravenously [8]. The iodinated fluorinated oils studied so far are too toxic for use *in vivo* [9].

Brominated perfluorocarbon-based contrast agents such as Imagent® BP (Alliance Pharmaceutical Corp., San Diego, USA) have essentially overcome these problems [10-14]. However, their radiopaque constituent, perfluorooctyl bromide (perflubron), contains bromine, which has a significantly lower opacity to radiations than does iodine. The finding of inert, biocompatible iodinated oils was desirable to further extend the range of applications of such materials in diagnosis and reduce the dose needed for obtaining suitable contrast [6, 7].

This paper deals with stable emulsions of a non-toxic iodinated fluorinated radiopaque (IFR) oil, utilizable as *i.v.* injectable contrast agents with prolonged intravascular persistence.

MATERIALS AND METHODS

Emulsions : One particular IFR, $C_6F_{13}CH=CIC_6H_{13}$ (F6H6IE), was selected for this study from a range of highly fluorinated molecules having an internally located iodine atom. A diluted emulsion ((20 % v/v, Emulsion I) and a concentrated emulsion (47 % v/v, Emulsion II) of this compound and a perflubron reference emulsion (47% v/v, Emulsion R) were prepared by microfluidization [8] (TABLE I). The emulsions were sterilized under standard conditions (121°C, 15 min, 15

TABLE I : Detailed composition of the emulsions used in this study.

Composition	Emulsions		
	I	II	R
% F6H6IE v/v (w/v)	20 (34)	47 (77)	-
% Perflubron v/v (w/v)	-	-	47 (90)
EYP	6	4	4
NaCl	0.88	0.55	0.55
EDTAN _{a2} ,2H ₂ O	0.06	0.039	0.039
NaH ₂ PO ₄ ,2H ₂ O	0.192	0.12	0.12
Na ₂ HPO ₄ ,12H ₂ O	1.488	0.93	0.93
α -Tocopherol	0.006	0.004	0.004
H ₂ O for injection	SQ 100 ml	SQ 100 ml	SQ 100 ml
pH post sterilization	7.2	7.3	7.2
Osmolarity	311	348	350
Viscosity coef (cp)	6.1	17.8	12.2

psi). The pH, osmolarity and viscosity coefficient were determined (TABLE I), and the mean particle sizes were monitored by photosedimentation during ageing at 40°C for several months (TABLE II).

Radiopacity measurements : All opacity measurements were made with a Philips Tomoscan LX 120 Kv, 175 mA apparatus.

Neat IFR : The opacity to X-rays of neat IFR was determined by analysing a 0.34 M solution of IFR in hexane.

Emulsified IFR : The IFR emulsions were tested for radiopacity in *ca* 1 kg New Zealand rabbits. The animals were held in a box and injected via the ear vein without prior anesthesia. Four groups of 3 animals each were injected respectively with 0.5 and 3 ml/kg bw of emulsion II, 1.5 ml/kg bw of emulsion I, and 3 ml/kg of emulsion R (control group) respectively. After administration of the emulsions, the density values of the liver and spleen were measured at 24 and 48 hours. CT examinations were carried out while the animal was held in a box. After localizing the scan, the abdomen was scanned using a slice thickness of 5 mm and an interval of 7 mm. The scan time was 1.2 second. A first series of 5 animals was scanned before injection of the contrast material and a mean value of the density of their liver and spleen was determined to serve as a baseline. For the same animal, the average density of 4-5 liver and spleen slice scans was established. A mean value was measured for the 3 injected animals in each group. The values are expressed in Hounsfield units (HU) \pm SEM.

TABLE II : Average particle sizes of IFR emulsions after ageing at 40°C ($\mu\text{m}\pm 10\%$)

Emulsion Composition		Average particle sizes				
	% v/v	before sterilization	after sterilization	30 days	60 days	90 days
I	20	0.08	0.20	0.21	0.19	0.23
II	47	0.08	0.39	0.47	0.43	-
R	47	0.09	0.12	0.22	0.23	0.26

Biological Tolerance :

Neat IFR : the tolerance of neat IFR was estimated by intraperitoneal injection of 10 mice at a dose of 25 ml/kg bw.

IFR emulsions : 2 groups of 10 SPF OFA Sprague Dawley rats (*ca* 200g) were injected intravenously (tail vein, 0.7 ml/min) with : 1) 10 ml/kg bw of emulsion II (7.7 g/kg bw of neat IFR) ; 2) 20 ml/kg bw of emulsion I. The latter was also tested in 10 OF1 male mice (*ca* 20 g) at a 25 ml/kg bw (8.5 g/kg of IFR).

Blood Analysis : Four groups of 3 rabbits were injected either with IFR emulsions I or II, or with the perflubron emulsion R (3 ml/kg bw dose) ; and 3 animals were taken as a control groups. Hematologic analyses were performed after 24, 48 h and 7 days.

Histology : After injection, the rabbits were anesthetized and sacrificed. The liver and spleen were removed and fixed in Boin's fluid, then embedded in paraffin, cut in 5 μm slices and stained with hematoxylin, eosine and saffron for histologic examination.

RESULTS

Both IFR emulsions could be heat-sterilized without pH variation. Sterilization resulted in an increase in average particle size, after which particle sizes remained essentially constant during a 3 months ageing period at 40°C (TABLE II).

The *in vitro* opacity of the F6H6IE solution was 4 times higher than that of perflubron for the same molar concentration.

Intravenous injection into rabbits of 3 ml/kg bw of the perflubron emulsion R (2.7 g/kg bw of perflubron) led to a contrast enhancement of 39 ± 2 HU (34 ± 7 HU) in the liver and 33 ± 4 HU (32 ± 1 HU) in the spleen after 24 hours (48 h).

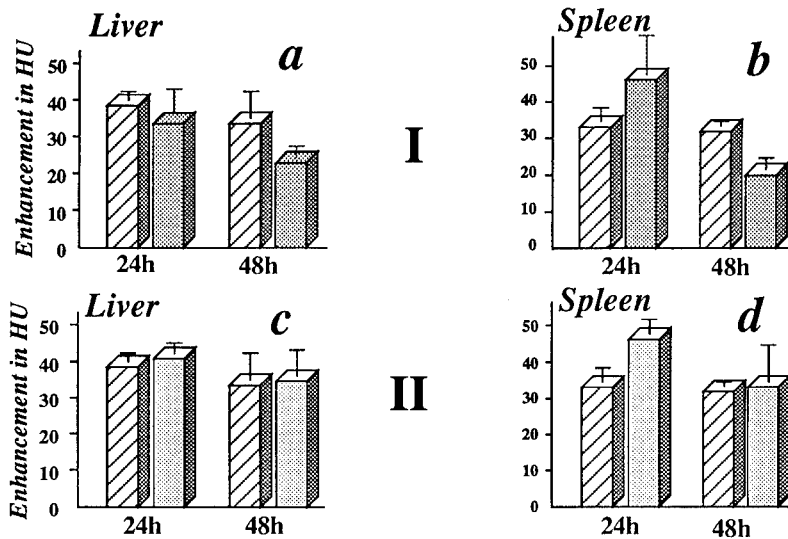

FIGURE 1 : Enhancement of the radiopacity of liver and spleen after injection of 1.5 ml/kg bw of emulsion I (a, b), 0.5 ml/kg bw of emulsion II (c, d) compared to 3 ml/kg bw of perflubron emulsion R.

Administration of F6H6IE emulsion I (1.5 ml/kg bw, 0.5 g/kg of F6H6IE) led to an equivalent enhancement after 24 hours in the contrast of the liver (34±8 HU), and a higher contrast of the spleen (46±11 HU), when compared with the perflubron emulsion injected at a ca 5 times higher dose (3 ml/kg bw, 2.7 g/kg of perflubron) (Figures 1 a, b).

Comparable or better contrast was obtained 24 h after injection of only 0.5 ml/kg bw of F6H6IE emulsion II (0.39 g/kg of IFR, Figures 1 c, d).

Figure 2 compares the contrast obtained in the liver and spleen after injection of the perflubron emulsion (3 ml/kg bw, 2.7 g/kg of perflubron), and of a 7 times smaller dose (0.39 g/kg bw of IFR) of IFR emulsions II, as determined by computed tomography (CT).

All the animals survived after injection of 1) neat F6H6IE intraperitoneally (45 g/kg bw) or 2) emulsified F6H6IE intravenously (emulsion I and II, 8 g/kg bw of IFR).

Blood analysis showed that the amounts of bilirubine, alkaline phosphatase and γ GT were comparable to those found in control animals (TABLE III). The

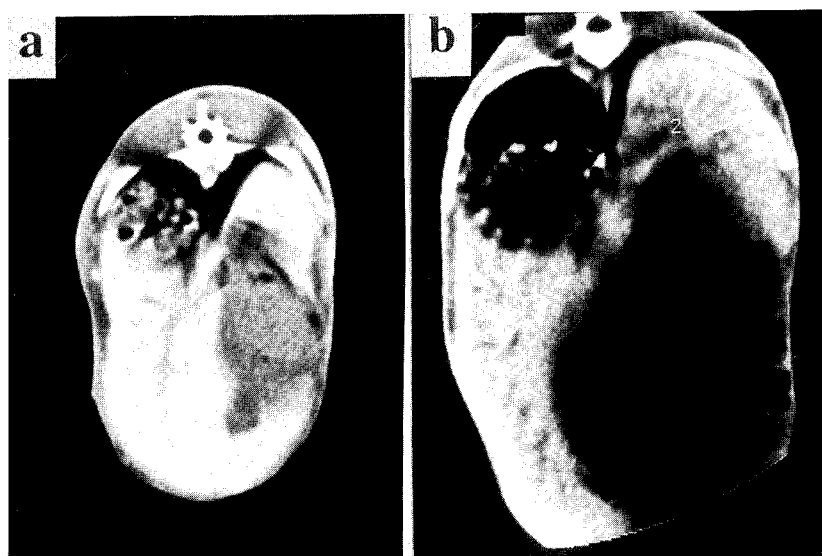

FIGURE 2: Computed tomography of the liver and spleen of rabbits after injection of a) F6H6IE emulsion II at 0.5 ml/kg bw (0.39 g/kg bw of F6H6IE) and b) perflubron emulsion R (3 ml/kg bw, 2.7 g/kg bw of perflubron).

TABLE III : Results of the rabbits' blood analysis after injection of the IFR emulsion II and the perflubron emulsion R.

	Time	Control	perflubron (Em R) 3ml/kg	F6H6IE (Em II) 0.5ml/kg
Gamma-GT	24 h	16.3	11	17
	48 h		17	18.7
	7 days		21	16
Alkaline phosphatase	24 h	142	113	154
	48 h		114.6	144
	7 days		103	148
Bilirubin	24 h	5.4	9.3	5
	48 h		14	7
	7 days		3.3	5

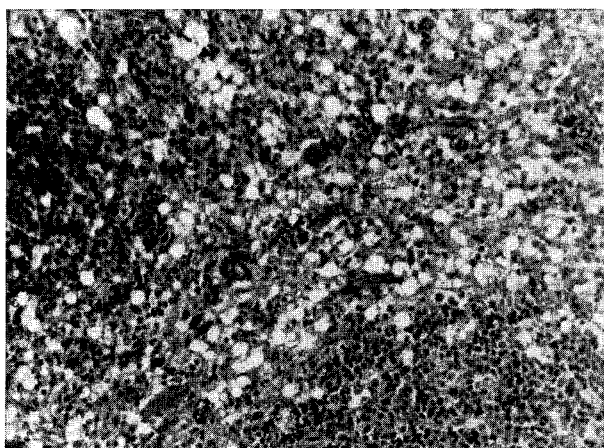

FIGURE 3: Histology of the rabbit's spleen 24 h after injection of Emulsion II at a 3 ml/kg bw dose.

histologic examination of the liver and spleen 24 hours after *i.v* injection of 3 ml/kg bw of the F6H6IE Emulsion II to rabbits showed the presence of frothy histiocytes (Figure 3).

DISCUSSION

The IFR compound tested, $C_6F_{13}CH=CIC_6H_{13}$ (F6H6IE), displays 4 and 7 times higher radiopacity than perflubron *in vitro* and *in vivo*, respectively. Maximum contrast, *in vivo*, was observed at 24 h for both 20% and 47% v/v IFR emulsions. As previously observed for perflubron [15, 16], the contrast in the spleen was higher than in the liver. At the same dose (3ml/kg bw), F6H6IE led to liver and spleen images which are significantly more enhanced than with perflubron. Consequently lower doses of IFR emulsions were required to achieve the same contrast as with perflubron: 5 and 7 times less for Emulsions I and II, respectively.

The neat IFR was tolerated *i.p.* in mice at 45 g/kg (10/10 survival after 1 month). Emulsified IFR was tolerated (10/10 survival after 1 month) in rats and mice *i.v.* at 8 g/kg bw dose. This dose corresponds to 15-20 times the dose required to achieve effective contrast with IFR emulsions. Blood analysis and

histological examination after intravenous injection into rabbits of IFR emulsions indicate that the hepatic functions were normal even when the liver was saturated with IFR at 24 and 48 hours. The half-life of the product in the liver was evaluated to be of *ca* 6 days for a large 3 g of IFR per kg bw dose [17].

Acknowledgments : We wish to thank the Centre National de la Recherche Scientifique, and Applications et Transferts de Technologies Avancées for support.

REFERENCES

- [1] A. Coussement et C. Fauret. Les produits de contraste en radiodiagnostic, *Expansion Scientifique Française*, Paris (1974).
- [2] T. Almén, *Amer. J. Cardiol*, **66**, 2F-8F (1990).
- [3] M. Westhoff-Bleck , J.S. Bleck and S. Jost, *Drug Safety*, **6**, 28-36, (1991).
- [4] N.E. Leeds, *Drugs*, **40**, 713-721 (1991)
- [5] M. Laval-Jeantet, J.L. Lamarque, P. Dreux, A.M. Laval-Jeantet and J. Launay, *Acta Radiologica Diagnosis*, **17**, 49-60 , (1976).
- [6] N. Patronas, D.L. Miller, M. Girton, *Invest. Radiol.*, **19**, 570-573 (1984)
- [7] M. Vermess, J.L. Doppman, P.H. Sugarbaker, R.I. Fisher, T.J. O'Leary, D.C. Charterji, G. Grimes, R.H. Adamson, M. Willis and B.K. Edwards, *Amer. J. Radiol.*, **138**, 1063-1071 (1982)
- [8] J.G. Riess, M.P. Krafft in "*Oxygen Transport to Tissues*" W. Erdmann, D.F. Bruley (eds), Plenum Publ. Corp. NY xxx (1993).
- [9] Le Vidal, (1992), p. 1562.
- [10] D.M. Long, C.B. Higgins, R.F. Mattrey, R.M. Mitten F.K. Multer, in "*Preparations, Properties and Industrial Applications of Organofluorine Compounds*" R.E. Banks (ed.), Ellis Horwood, Chichester, 139-156, (1982)
- [11] D.C. Long, D.M. Long, J.G. Riess, R. Follana, A. Burgan and R.F. Mattrey, in "*Blood Substitutes*", TMS Chang and R.P. Geyer eds, Marcel Dekker Inc., New York , 441-442, (1989)
- [12] D.M. Long, D.C. Long, R.F. Mattrey, R.A. Long, A.R. Burgan, W.C. Herrick and D.F. Shellhamer in "*Blood Substitutes*", TMS Chang and R.P. Geyer eds, New York, Marcel Dekker Publisher, 411-420 (1989).
- [13] S. Flaim, *Abstract of Intl. Symp. Blood Substitutes*, Montreal (1991).
- [14] J.G. Riess, in "*Blood Substitutes and Oxygen Carriers*", TMS Chang (ed), Marcel Dekker Inc, New York, 24-43 (1993).
- [15] R.F. Mattrey, *Amer. J. Radiol.*, **152**, 247-252 (1989).
- [16] J.N. Bruneton, M.N. Falewée, E. François, P. Cambon, C. Philip, J.G. Riess, C. Balu-Maestro, A. Rogopoulos, *Radiology*, **170**, 179-183 (1989)
- [17] L. Zarif, V. Sanchez, B. Septe, J. Greiner, J.G. Riess ; *J. Pharm. Res.* (Submitted)

PRECLINICAL AND CLINICAL STUDIES ON LYMPH NODE IMAGING
USING PERFLUBRON EMULSION

G. Hanna¹, D. Saewert¹, J. Shorr¹, K. Flaim¹,
P. Leese², M. Kopperman³ and G. Wolf⁴

¹Alliance Pharmaceutical Corp., San Diego, CA 92121

²Clinical Research Foundation - America, Lenexa, KS 66219

³Diagnostic Imaging Center, Overland Park, KS 66211

⁴CIPR, Massachusetts General Hospital, Charlestown, MA 02129

A perflubron emulsion is being developed as a contrast agent to enhance lymph nodes on computed tomography (CT) images. The emulsion is administered by percutaneous injection into the drainage field of the lymph nodes to be imaged. A series of preclinical studies was conducted to investigate the efficacy of the perflubron emulsion for enhancement of lymph nodes on CT images. The effects of dose (0.10 to 0.50 mL), application of massage, and route of administration were investigated in healthy New Zealand white rabbits. Results of these studies demonstrated that doses as low as 0.15 mL were efficacious for consistent enhancement of axillary lymph nodes on CT images after subcutaneous injections in the forepaw. Application of massage to the injection site decreased the time for maximum nodal enhancement from approximately 7 days to 2 days postinjection. A pilot study conducted in 18 healthy, male volunteers indicated dose-related enhancement of axillary lymph nodes on CT images following subcutaneous injections of the emulsion in the hand. Other than mild, transient injection-site discomfort, no clinically significant side effects were observed. These data demonstrate that the perflubron emulsion is safe and can enhance axillary lymph nodes on CT images following injections in the hand.

INTRODUCTION

The thin-walled and fenestrated lymphatic microvessel is easily penetrated by cancer cells. Once inside the lymphatic vessel, cancer cells can be carried to a lymph node, migrate to other nodes along the lymphatic chain, and eventually reach the blood stream for dissemination. The

presence and extent of lymph node involvement often represent the most significant prognostic indicators for a patient [1-5]. Thus, accurate staging of lymph node involvement following diagnosis of a primary cancer is essential for determination of treatment.

The most accurate method for detecting nodal metastases to date is lymphadenectomy with histologic evaluation of the lymph nodes draining the region of a primary neoplasm [6]. However, lymphadenectomy is associated with significant morbidity [2,7].

Lymphangiography (direct lymphography), a minor surgical procedure in which relatively large lymphatic vessels are identified, isolated, perfused with an iodinated lipid contrast agent, and subsequently imaged by conventional radiography, is the only technique available to show intranodal architecture [8,9]. Several disadvantages are associated with this technique, including: (a) a high incidence of false positive and false negative findings in detection of early cancer extensions [9]; (b) it is invasive, difficult, and time consuming [10]; (c) it involves the use of ethiodized oil, which is contraindicated in patients with known iodine hypersensitivity; and (d) its use is limited to cancers that have accessible lymphatic drainage systems.

CT, sonography, and magnetic resonance have also been used to image lymph nodes. The effectiveness of these modalities has been inconsistent and each method has been associated with high rates of false positive and false negative findings.

A reliable, nonsurgical method of determining the presence or absence of lymph node metastases would be of great value [2,4,5]. One approach would be indirect lymphography, which would involve diagnostic imaging of lymph nodes following injections of a particulate contrast agent into the extracellular space, rather than directly into the lymphatic vessel [11,12]. This method would require the uptake of the contrast agent into the lymphatic vessel and into the lymph nodes, which would be enhanced on CT images to show their internal architecture as well as their size. Such a contrast agent would be of benefit for determining regional spread of cancer and in subsequent selection of appropriate therapeutic procedures.

Preclinical studies were conducted in rabbits to evaluate the use of a perflubron emulsion formulation as a contrast agent for indirect lymphography [13]. In these studies, the effects of dose, application of massage, and route of administration on the enhancement of lymph nodes on CT images were investigated. The safety and efficacy of the same perflubron emulsion formulation were evaluated in a Phase I clinical study.

MATERIALS AND METHODS

Preclinical Studies

New Zealand White rabbits were used in the preclinical studies. Prior to injection of perflubron emulsion, each animal was anesthetized using a ketamine/xylazine cocktail (0.6 mL/kg

of body weight) via an intramuscular injection into the thigh. The injection site was shaved and cleaned with an antiseptic wipe. At the appropriate time postinjection, the animals were anesthetized, a CT was performed using a General Electric 9800 CT scanner, and the images were analyzed using the SUN SPARC Station 1. Sodium bromide standards of known concentrations were imaged along with each animal and used to construct curves for each CT image to estimate perflubron levels in the enhanced lymph node. As a rule, a single enhanced lymph node was chosen for quantification following percutaneous administration of perflubron emulsion into the regional drainage field.

Three preclinical studies were conducted. In one study, doses ranging from 0.10 to 0.50 mL were injected subcutaneously (s.c.) into the forepaw to investigate the effect of perflubron emulsion dose on the level of enhancement of axillary lymph nodes on CT images. In a second study, the effects of application of manual massage to the injection site on the kinetics and extent of enhancement of axillary lymph nodes on CT images were investigated. In this study, animals were injected s.c. with either 0.10 or 0.25 mL of perflubron emulsion. Manual massage (three 5-minute periods of hand massage within 45 minutes postinjection) was applied to the injection site on the right forepaw; the left forepaw received no massage. It was hypothesized that the application of massage would facilitate movement of the perflubron emulsion through the lymphatic channels. In a third study, the effect of route of administration on the enhancement of axillary lymph nodes was evaluated. In this study, animals were injected subcutaneously (s.c.), intradermally (i.d.), and intramuscularly with 0.25 mL of perflubron emulsion. Analysis of variance (ANOVA) was performed with a significance level of $p = 0.05$.

Clinical Study

In the Phase I clinical study, 18 healthy, male volunteers were randomized to one of three dose groups to receive either 1.0, 2.0, or 4.0 mL perflubron emulsion. The emulsion was injected subcutaneously between the first, second, third, and fourth dorsal metacarpals on the subject's nondominant hand at doses of 0.25, 0.50, or 1.0 mL per injection. Safety was monitored through assessment of hematology, coagulation, blood chemistry, urinalysis, and vital signs parameters prior to dosing and 1, 3, 7, 14, and 28 days postdosing. Subjects were evaluated for signs and symptoms of adverse events immediately postdosing and at all follow-up visits. Pilot efficacy was assessed by comparison of CT scans of the axillary region performed prior to dosing with scans obtained 1, 3, 7, 14, and 28 days postdosing. ANOVA methods were applied to efficacy evaluations.

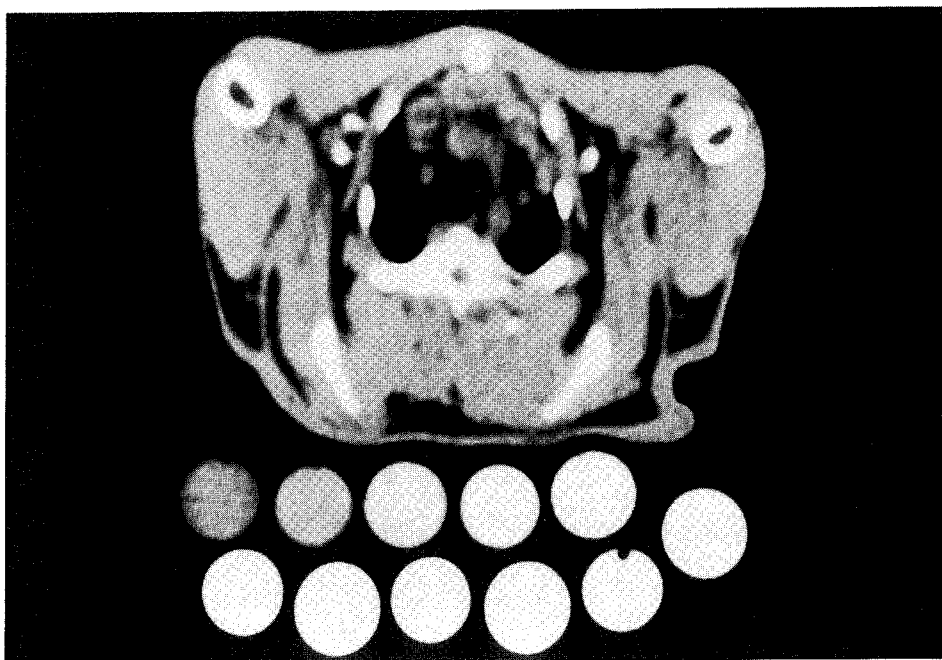

FIGURE 1. CT image of enhanced rabbit axillary lymph nodes 24 hours postinjection of a 0.25-mL dose administered s.c. into the right and left forepaw (80 kV, 140 mA, 1.5 mm slice, 2.0 mm slice spacing).

RESULTS AND DISCUSSION

Preclinical Studies

Effect of dose. Results indicated that enhancement of lymph nodes on CT images was achieved following s.c. injection of perflubron emulsion into the drainage field of the targeted nodes (Figure 1). All doses studied were effective for enhancing axillary lymph nodes on CT images after s.c. injections in the forepaw (Figure 2). Although no correlation between the dose administered and the estimated perflubron concentration in the enhanced lymph node was demonstrated, a dose-related effect was noted with regard to the number of animals for which significant enhancement*

* The minimum perflubron concentration required for enhancement of a lymph node on CT was determined to be approximately 8 mg/mL. However, because this concentration results in an enhancement level barely distinguishable from background soft tissue on CT, a perflubron concentration of approximately 37 mg/mL was used to define significant enhancement. This value was used in all studies to define a threshold for unequivocal enhancement of a lymph node.

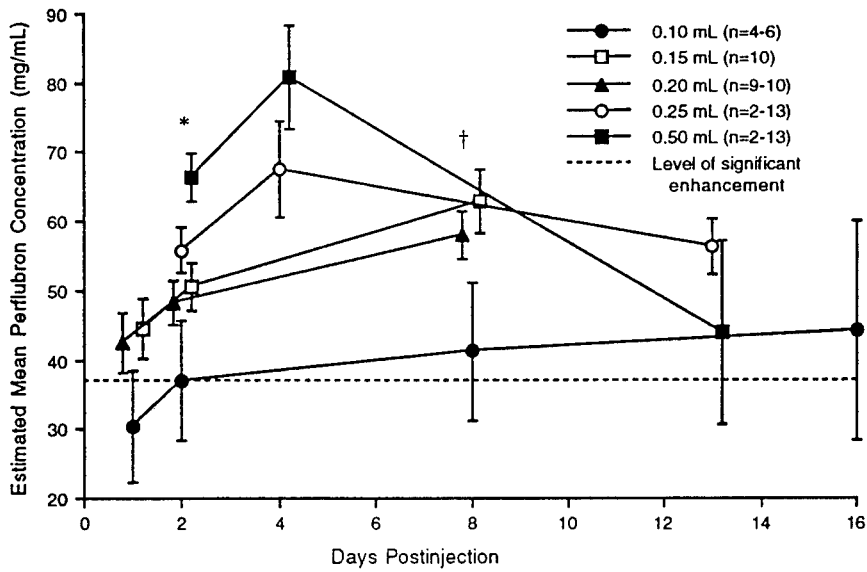

FIGURE 2. Effect of perfubron emulsion dose on the level of enhancement of axillary lymph nodes following subcutaneous injections in the forepaw of rabbits. Statistically significant differences between 0.10- and 0.25-mL doses (*); statistically significant differences between 0.10- and 0.15-mL doses (†).

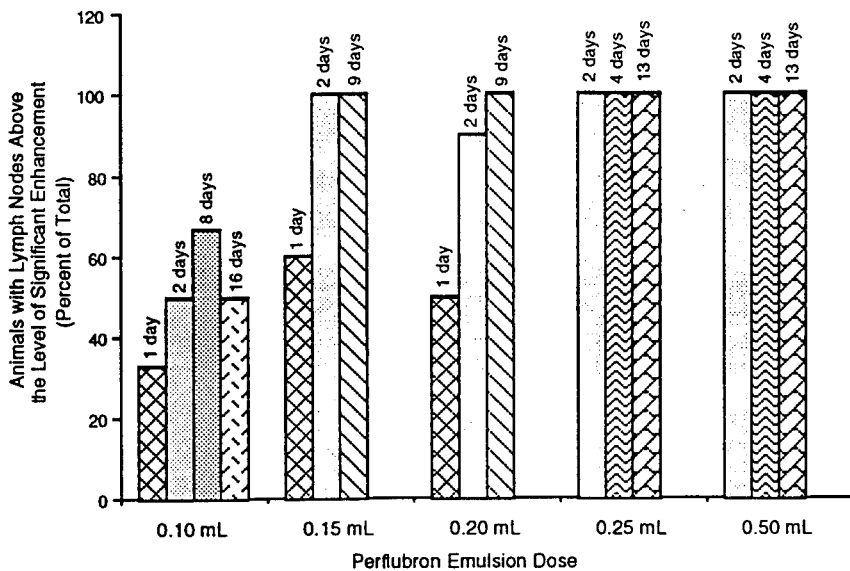

FIGURE 3. Effect of perfubron emulsion dose on the frequency of enhancement of axillary lymph nodes following subcutaneous injections in the forepaw of rabbits.

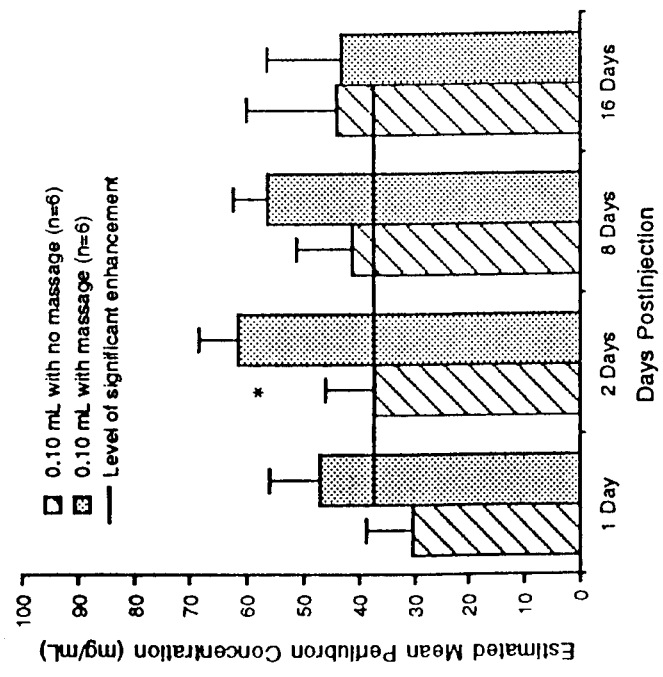
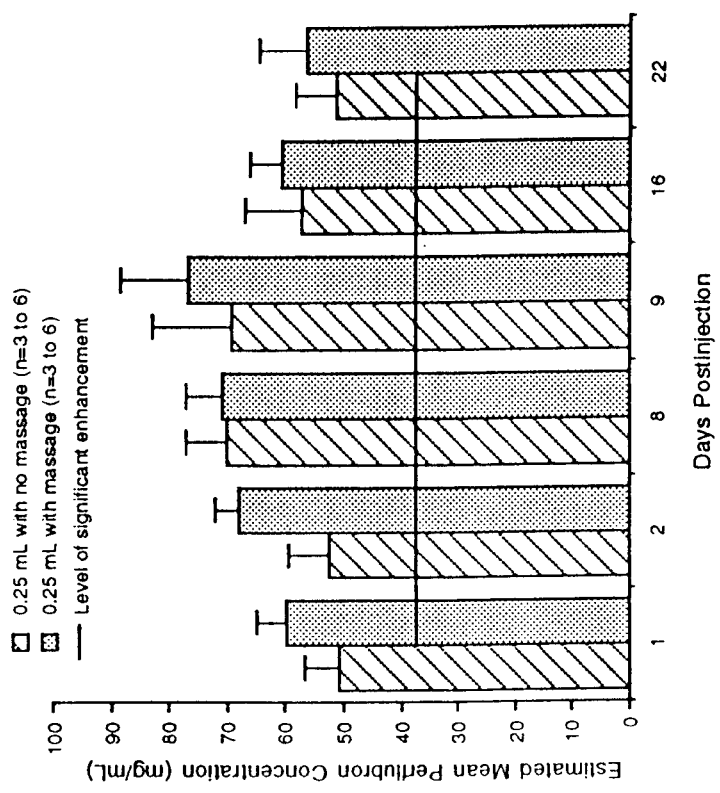

FIGURE 4. Effect of injection site massage on enhancement of axillary lymph nodes following subcutaneous injections in the forepaw of rabbits.

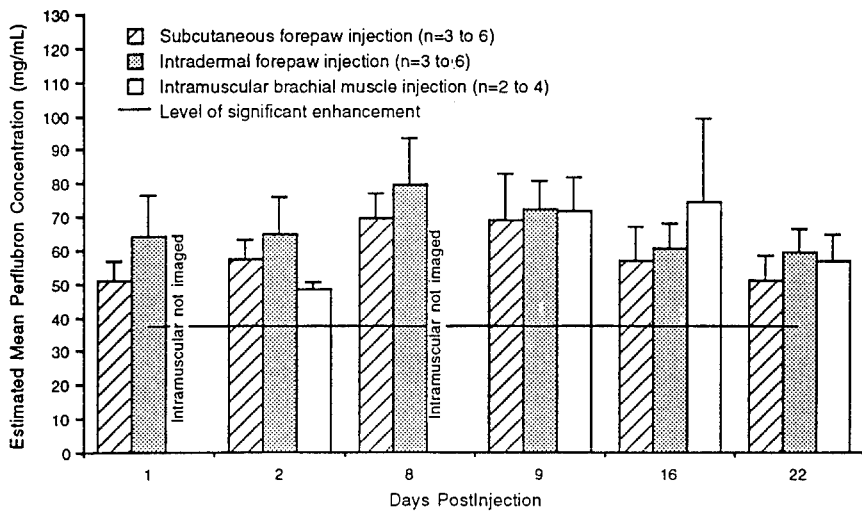

FIGURE 5. Effect of the route of administration on enhancement of rabbit axillary lymph nodes. No statistically significant differences among groups.

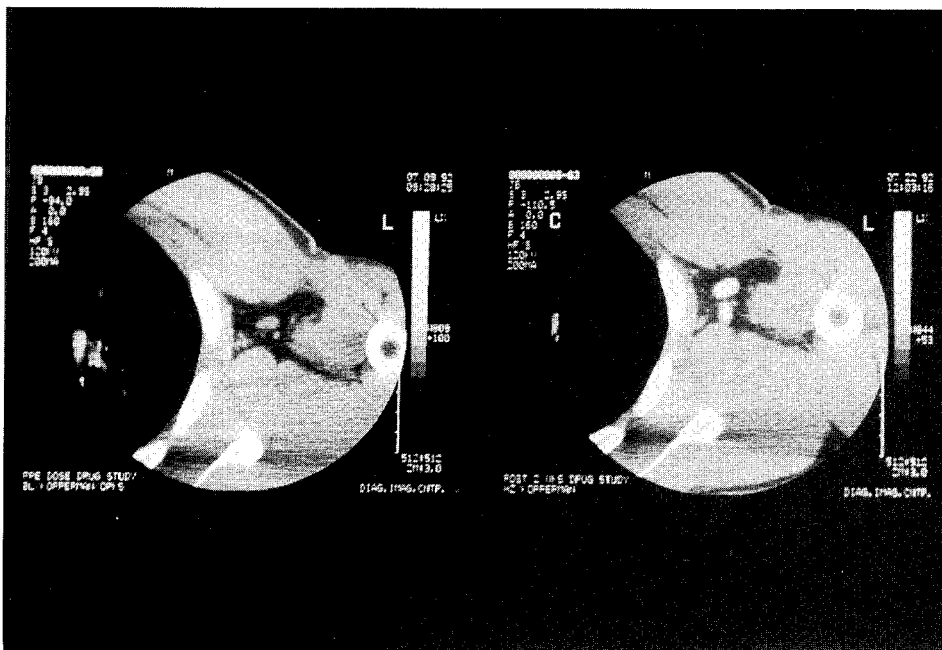

FIGURE 6. CT image of enhanced human axillary lymph nodes following subcutaneous injection of 4.0 mL perflubron emulsion dose in the hand. Left: preinjection; right: 14 days postinjection (120 kV, 200 mA, 3 mm contiguous slice).

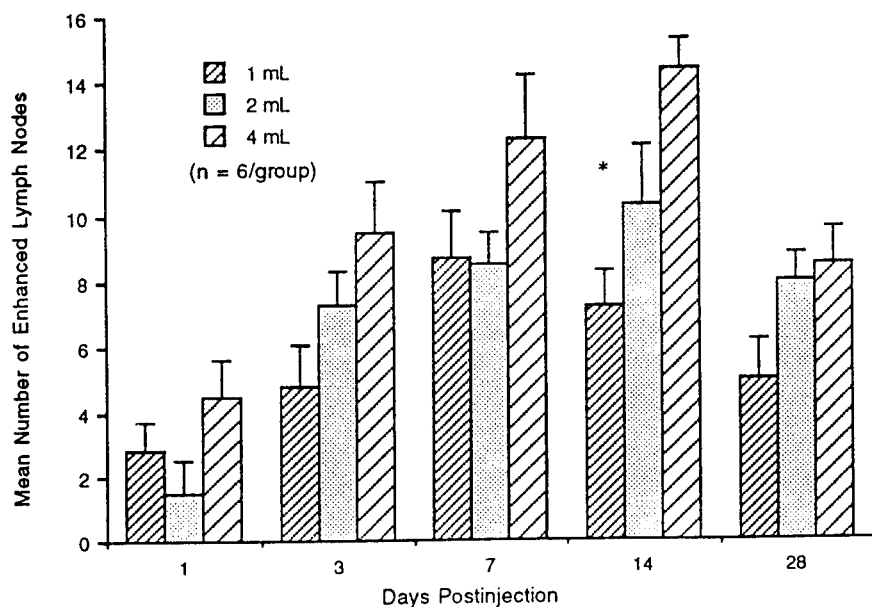

FIGURE 7. The effect of dose on the mean number of enhanced human axillary lymph nodes. Statistically significant differences between 1- and 4-mL doses.

was observed. The results indicated that a 0.10-mL dose did not consistently and reliably enhance an axillary lymph node on CT: at 2 and 8 days postinjection, an axillary node was enhanced in only 3 of 6 animals and 4 of 6 animals, respectively (Figure 3). However, at the higher doses (0.15 to 0.50 mL), significant enhancement of the axillary node was consistently observed for all animals at 2 days postinjection. These results suggested that a minimum dose of 0.15 mL was required for consistent enhancement of axillary lymph nodes following a s.c. injection in the forepaw.

Effect of massage. Application of massage to the injection site resulted in a significant increase in the mean perflubron concentration for the 0.10-mL dose and significant enhancement was noted as early as 1 day postinjection (Figure 4). However, for the 0.25-mL dose, application of massage to the injection site did not result in a significant effect on the estimated mean perflubron concentration in the lymph node. Both with and without massage, maximal enhancement occurred at 8 to 9 days postinjection. Based on these data, massage application was

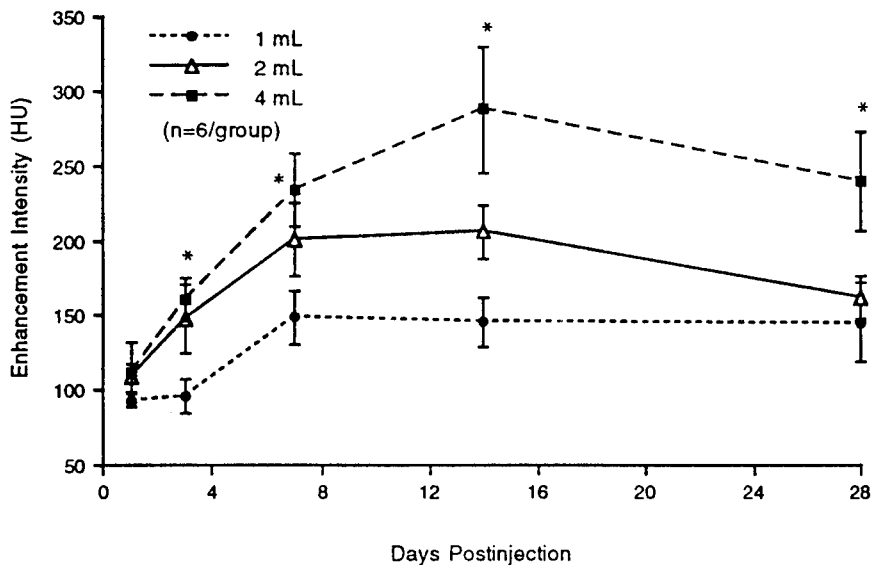

FIGURE 8. Dose-response relationship: human axillary lymph nodes with the greatest degree of enhancement. Statistically significant differences between 1- and 4-mL doses on days 3, 14, and 28 and between the 2- and 4-mL doses on days 14 and 28.

effective for increasing the degree of enhancement and reducing the time to reach maximal enhancement only at the 0.10-mL dose.

Effect of route of administration. All three routes of administration (s.c., i.d., i.m.) were equally effective for axillary lymph node enhancement following injection of 0.25 mL perflubron emulsion (Figure 5). With each route, an axillary lymph node was enhanced at the earliest imaging time point (1 to 2 days postinjection) for all animals. Maximum perflubron concentration was noted 8 to 9 days postinjection; perflubron concentration declined gradually over the subsequent 2 weeks (22 days postinjection).

Clinical Study

Safety. Evaluation of safety data indicated that, other than mild injection-site discomfort (e.g., redness, swelling), no clinically significant adverse events were observed. For most subjects who experienced injection-site discomfort, the events were brief, resolving within 2 hours of dosing.

Pilot Efficacy. Dose-related enhancement - in terms of both the number of lymph nodes opacified and the level of enhancement - of axillary lymph nodes on CT images was observed following s.c. injections of the perflubron emulsion in the hand (**Figure 6**). At the 4-mL dose, the highest number of opacified lymph nodes (**Figure 7**) and the greatest degree of enhancement (**Figure 8**) were observed 14 days postinjection.

SUMMARY

Results from the preclinical and clinical studies demonstrated the safety and utility of a perflubron emulsion for enhancing lymph nodes on CT images. This perflubron emulsion formulation could be valuable as a contrast agent for use in the staging of cancers.

REFERENCES

1. RM Bryan, RJ Mercer, RC Bennett, GC Rennie. *Br. J. Surg.* 73:267-271 (1986).
2. M Gasparini, C Andreoli, A Rodari, A Costa, GL Buraggi. *Eur. J. Cancer Clin. Oncol.* 23:481-485 (1987).
3. IC Henderson, JR Harris, DM Kinne, S Hellman. Cancer of the breast. In: VT DeVita Jr, S Hellman, SA Rosenberg, eds. *Cancer—Principles and Practice of Oncology*. 3rd ed. Philadelphia: JB Lippencott Co. 1197-1268 (1989).
4. DE March, RJ Wechsler, AB Kurtz, AL Rosenberg, L Needleman. *J. Comput. Assis. Tomogr.* 15:440-444 (1991).
5. IS Sawczuk, RV White, RP Gold, CA Olsson. *Urology*. 21:81-84 (1983).
6. DF Paulson, Uro-Oncology Research Group. *J. Urol.* 121:300-302 (1979).
7. CA Perez, WR Fair, DC Ihde. Carcinoma of the prostate. In: VT DeVita Jr., S. Hellman, SA Rosenberg, eds. *Cancer—Principles and Practices of Oncology*. 3rd ed. Philadelphia: JB Lippencott Co. 1023-1058 (1989).
8. SJ Golding. *Br. J. Hosp. Med.* 41:152-157 (1989).
9. AB Crummy, ME Peters. The superficial soft tissues. In: JH Juhl, AB Crummy, eds. *Essentials of Radiologic Imaging*. 5th ed. Philadelphia: JB Lippencott Co. 347-384 (1987).
10. H Weissleder, R Weissleder. *Radiology*. 170:371-374 (1989).
11. DM Long, DC Long, RF Mattrey, RA Long, AR Burgan, WC Herrick, DF Shellhamer. *Biomat., Art., Cells, Atr. Org.*, 16: 411-420 (1988).

12. G Wolf, D Long, J Riess. *Radiology*, 177: 366 (1990). Abstract.
13. JG Riess, JL Dalfors, GK Hanna, DH Klein, M-P Krafft, TJ Pelura, EG Schutt. *Biomat., Art. Cells and Immob. Biotech.* 20:839-842 (1992).

INTRACELLULAR AND EXTRACELLULAR TRANSPORT OF
PERFLUORO CARBON EMULSION FROM SUBCUTANEOUS
TISSUE TO REGIONAL LYMPHATICS.

F. Ikomi, G. Hanna,* and G. W. Schmid-Schönbein
Institute for Biomedical Engineering, University of California,
San Diego, La Jolla, CA
and *Alliance Pharmaceutical Corp., San Diego, CA

The aim of this study was to examine the transport mechanism of colloidal particles from subcutaneous tissue to lymphatics. The mechanism of lymph transport was studied in leg prenodal lymphatics of anesthetized rabbits using Imagent®LN (60%W/V perfluorooctyl bromide [PFOB] emulsion). Extracellular (dispersed particles) and intracellular (phagocytosed particles by macrophages) PFOB transport was measured in lymph fluid after 0.1ml injection of fluorescently labeled PFOB emulsion into the dorsal skin of the rabbits' foot. Samples were collected from cannulated lower leg prenodal lymphatics. Particles of PFOB emulsion were observed by using a fluorescent technique. The foot/leg were moved passively in a rotary direction at 0.3Hz. Extracellular and intracellular PFOB could be determined in the lymph samples. These findings indicate that both intracellular and extracellular transport mechanisms play a role in the uptake of colloidal particles from interstitial tissue to lymphatics.

INTRODUCTION

Functions of the lymphatic system include not only return of excess tissue fluid to the intravascular compartment but also uptake of

large particles from interstitial space. This phenomenon has been applied to collect drugs in lymph node for diagnosis and treatment of lymphatic metastasis of cancer [1, 2]. However, detailed transport mechanisms of large particles from interstitial tissue to lymph nodes are not well defined.

Perfluorooctyl bromide (PFOB) is a brominated fluorochemical, which is radiopaque [3] and has the ability to carry oxygen [4]. By use of these physical characteristics, PFOB emulsion has been used as X-ray contrast medium [3] and as an adjuvant to tumor radio therapy [4] and for other uses in diagnosis and therapy [5]. By phagocytosis of that chemical by macrophages or related cells, liver spleen, tumors [6] and inflammatory tissues [7] can be distinguished with CT. Transport of a colloidal material in the lymphatic system may take place in form of dispersed *extracellular* particles in free suspension and via an *intracellular* pathway after phagocytosis by macrophages. The magnitude of each transport mechanism with any selected emulsion is, however, unexplored.

In order to examine the transport of colloidal PFOB particles from subcutaneous tissue to lymphatics, we measured the extracellular and intracellular transport in lymph after subcutaneous injection in the rabbit hind leg.

MATERIALS AND METHODS

Experiments were performed on male New Zealand White rabbits (2.0-3.0kg) anesthetized with ketamine chloride (20mg/kg I.V.) and pentobarbital sodium (20mg/kg I.V.). Lymph fluid was collected by cannulating one of the lymphatics in the lower leg before it enters the popliteal node. The size of the lymph channels was in the range of about 200 μm . Cannulations were made under a binocular microscope. During lymph collection, the rabbit foot/leg was moved passively in a circular direction at a frequency of 0.3Hz. Selected experiments were also carried out without passive foot/leg passive movement.

To determine the concentration of PFOB particles, we used the following fluorescent labeling technique. A 10^{-3} M stock solution of

the fluorescent stain PKH-26 (Zynaxis Cell Science, Inc., Malvern, PA) was added to the PFOB emulsion (60%W/V; Imagent®LN, Alliance Pharmaceutical Corp., San Diego, CA) to a final PKH-26 concentration of 10^{-5} M. The mixture was gently mixed in the dark for 5 min at room temperature. Subsequently, the PFOB/PKH-26 mixture was added in equal volume to rabbit plasma and gently shaken for 1 min to stop the staining reaction. The final concentration of fluorescently stained PFOB emulsion was 30%W/V. PFOB emulsion includes 4%W/V egg yolk phospholipid as surfactant and each PFOB particle is presumed to have a phospholipid layer on its surface. PKH-26 is a fluorescent dye which is used for labeling of cell membrane phospholipid layers. Leukocytes in lymph samples were detected by transillumination microscopy. The fluorescently stained PFOB particles were observed under a fluorescence microscope (Leitz, Ploempak, N2.1 filter set) with 100 x objective. The images were recorded with a silicone intensified target television camera (Dage, Model 66), stored on video tape and analyzed on a television monitor.

Lymph collection was carried out 24hrs after injection of fluorescently labeled PFOB (0.1ml) into the dorsal skin of the foot. Samples were collected over a period of 2hrs and assayed for extracellular and intracellular PFOB concentration. After this protocol, the position of the drainage area of the cannulated lymphatic was confirmed by injection of Evans blue dye with 2% albumin subcutaneously in the same area where the colloidal suspension has been injected previously.

RESULTS

Both extracellular and intracellular PFOB particles were observed in lymph after subcutaneous injection of PFOB emulsion. The extracellular and intracellular particles could clearly be separated since extracellular particles showed rapid Brownian motion in free solution, whereas intracellular phagocytosed particles exhibit slow movement which is synchronized with the motion of cells. The concentration of intracellular particles was $8.1 \pm 2.2 \times 10^{-4}$ $\mu\text{g/ml}$

(mean \pm SE) at an average leukocyte count in the lymph fluid of 208 ± 24 cell/mm³. In contrast the extracellular concentration of PFOB was about 3 - 4 orders of magnitude higher, 2.3 ± 0.6 μ g/ml.

Figure 1 shows the lymph flow rate of rabbits' lower leg with and without passive movement of the foot/leg. This passive movement increased the lymph flow rate (0.188 ± 0.024 ml/h) compared with its steady state value (0.007 ± 0.002 ml/h).

DISCUSSION

The present study demonstrates that colloidal particles can be taken up into the initial lymphatics by both an extracellular and intracellular transport mechanism.

Sherman and Ter-Pogossian [8] showed that subcutaneously injected colloidal solutions (Au; 50-250nm in diameter) were transported into the regional nodes where they were trapped and concentrated. Subsequently several kinds of radioactive colloids have been used to identify regional lymph nodes [2, 9] for treatment of cancer.

The current evidence suggests that extracellular particles enter initial lymphatics by passing through gaps between lymphatic endothelial junctions and possibly also through the endothelium via a phagocytic transport [10, 11]. This is possible, since lymphatic endothelium is specialized without a continuous basement membrane. It is anchored to the tissue parenchyma at local points of attachment [12]. Surface views of initial lymphatics by scanning electron microscopy show that cell borders are only partially fused with neighboring cells with an overlapping attachment structure that may effectively act like an endothelial microvalve system. The discontinuous arrangement of tight lymphatic interendothelial junctions can be demonstrated by stretching of the initial lymphatics after inflation. Stretching serves to open these interendothelial junctions to a degree which results in gaps of several micrometers [13]. Thus mechanical expansion of the initial lymphatics causes filling by fluid which enters from the interstitial space via convection and thus provides

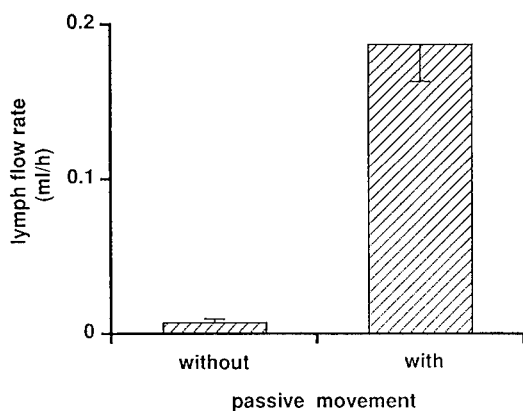

FIGURE 1. The effect of passive foot/leg movement on the lymph flow rate of rabbit hind leg. The foot and hind leg were moved in a circular direction (with radius 3.5 cm) at a frequency of 0.3Hz while the animal was resting spine on it back. The strong effect of foot/leg motion on lymph flow rate was observed in each animal without exception. Each value represented the mean with SE shown by the vertical bar. Number of rabbits, $n = 4$.

a transport mechanism for colloidal material. The degree of filling of the initial lymphatics depends on the rate of tissue deformation, i.e. the rate of lymphatic expansion and compression. The passage of particles (50nm-1 μ m) from the peritoneal cavity of mice into diaphragmatic lymphatics has been reported to take place through both interendothelial junctions and directly through the cytoplasm [14]. Similar results were obtained during transport of chylomicra and lipoprotein through jejunal lacteals [15].

A fraction of subcutaneously injected colloidal particles may be phagocytosed by macrophages which then in turn migrate into initial lymphatics. Macrophages have the ability to phagocytose foreign particles and are a regular component of lymph from afferent lymphatics [16]. Emulsified PFOB (perfluorooctyl bromide) is collected at lesions of malignant tumor [3] and inflammation [7]. This

suggests that macrophages may engulf PFOB particles at the injection site as well as in the lymphatics. Recently, Tsuda et al. [17] showed that perfluorochemical emulsion can be phagocytosed by macrophages in vivo by using a wave length dispersive X-ray micro analyzer. Particle transport by macrophages, however, was only suggested at selected immunologically specific sites where phagocytic cells can be detected, such as BALT (bronchial-associate lymphoid tissue). Harmsen et al. [18] reported that lung macrophages phagocytose injected microspheres in the lung and carried them to the tracheobronchial lymph nodes.

In summary, the present study demonstrates that there are at least two kinds of transport mechanisms for colloids from subcutaneous tissue to lymphatics. Both are dependent on tissue motion. These observations may be important for the use of colloidal materials in diagnosis and treatment of lymphatic metastasis of cancer.

ACKNOWLEDGMENT

The authors thank Professor B. W. Zweifach for suggestions. We also thank Professor E. Renkin, University of California at Davis, for providing the electric motor used to passively move the rabbit hind leg.

REFERENCES

- (1) A.I.Sherman, M.Bonebrake and W.M.Allen, *Am. J. Roentgenol. Rad. Therapy.* 66, 624 (1951)
- (2) J.Lock-Andersen, N.Rossing and K.T.Drzewiecki, *Cancer* 63, 77 (1989)
- (3) D.M.Long, F.K.Multer, A.G.Greenburg, G.W.Peskin, E.C.Lasser, W.G.Wickham and C.M.Sharts, *Surgery* 84, 104 (1978)
- (4) C.Thomas, J.Riess. and M.Guichard, *Int. J. Radiat. Biol.* 59, 433 (1991)
- (5) J.G.Riess, J.L.Dalfors, G.K.Hanna, D.H.Klein, M.-P.Krafft, T.J.Pelura and E.G.Schutt, *Biomat. Artif. Cells Immob. Biotech.* 20, 839 (1992)

- (6) R.F.Mattrey, D.M.Long, F.Multer, R.Mitten and C.B.Higgins, *Radiology* 145, 755 (1982)
- (7) D.J.Sartoris, J.Guerra,Jr., R.F.Mattrey, D.Resnick, P.Haghighi, R.Mitten, D.Trudell and D.Pate, *Invest. Radiol.* 21, 49 (1986)
- (8) A.I.Sherman and M.Ter-Pogossian, *Cancer* 6, 1238 (1953)
- (9) R.L.Wahl, M.Liebert, B.S.Wilson and N.A.Petry, *Int. J. Radiat. Appl. Instrum. Part B Nucl. Med. Biol.* 15, 243 (1988)
- (10) J.R.Casley-Smith, *J.Anat.* 103, 202 (1968)
- (11) G.W.Schmid-Schönbein, *Physiol. Rev.* 70, 987 (1990)
- (12) L.V.Leak and J.F.Burke, *Am. J. Anat.* 118, 785 (1966)
- (13) A.Castenholz, *Scanning Electron Microscopy* 1984, 1343 (1984)
- (14) J.R.Casley-Smith, *Quart. J. Exp. Physiol.* 49, 365 (1964)
- (15) J.R.Casley-Smith, *J. Cell. Biol.* 15, 259 (1962)
- (16) J.B.Smith, G.H.McIntosh and B.Morris, *J. Anat.* 107, 87 (1970)
- (17) Y.Tsuda, K.Nakura, K.Yamanouchi, K.Yokoyama, M.Watanabe, H.Ohyanagi and Y.Saitoh, *Artif. Organs* 13, 197(1989)
- (18) A.G.Harmsen, B.A.Muggenburg, M.B.Snipes, and D.E.Bice, *Science* 230, 1277 (1985)

MONITORING OF pO_2 BY SPIN-SPIN RELAXATION RATE $1/T_2$ OF ^{19}F IN A RABBIT ABSCESS MODEL

Quanzhong Guo¹, Ph.D. R. F. Mattrey¹, M.D., C. Guclu M.S.²,
R.B. Buxton¹ Ph.D., and O. Nalcioglu², Ph.D.

Department of Radiology, University of California, San Diego (1) and Irvine (2).
MRI Institute, 410 Dickinson St, San Diego, California 92103.

ABSTRACT

The purpose of this study was to confirm the relationship of T_1 and T_2 relaxation rate vs. pO_2 *in vivo* of ^{19}F MR signal measured from intracellular perflubron. Our work to date has demonstrated that $1/T_2$ is more sensitive to pO_2 than $1/T_1$ in the *in vitro* environment. The advantage of $1/T_2$ vs. $1/T_1$ is the speed of measurement and sensitivity.

Seven alternating T_1 and T_2 measurements were obtained during a continuous acquisition using the TTISS pulse sequence. An abscess model was used for the *in vivo* experiments where rabbits were infused with 5ml/kg Oxygent[®] HT 10 days prior to scanning. The abscess model was used because it has been shown that perflubron accumulates in macrophages located in the abscess wall. This technique thus provided signal from the intracellular milieu.

The results of this study proved that pO_2 monitoring by measuring T_2 of ^{19}F is feasible and can be used in-lieu of the T_1 measurement. Given that the T_2 measurement is much more rapid than the T_1 measurement and that T_2 changes are more sensitive than T_1 changes with alterations in pO_2 , T_2 should prove to be practical and useful for monitoring transient rapid changes in pO_2 .

INTRODUCTION

Our *in vitro* studies have shown that the transverse relaxation rate of $1/T_2$ of perflubron (perfluorooctyl bromide) does not only vary linearly with the

dissolved pO_2 but is also more sensitive than $1/T_1$ to pO_2 changes.^[1,2] In our preliminary studies we have shown that the relationship of $1/T_2$ and $1/T_1$ to pO_2 may be the same *in vivo* as it is *in vitro*.^[2] It is known that perflubron emulsion (Oxygent® HT, Alliance Pharmaceutical Corp., San Diego) is an efficient oxygen carrier.^[3] It is also known that perflubron accumulates within macrophages in the abscess wall following the administration of a 100% w/v perflubron emulsion.^[4] Therefore, using the abscess model, it is possible to evaluate the intracellular pO_2 level within macrophages. The purpose of this study was to more rigorously confirm the relationship of T_1 and T_2 relaxation rates vs. pO_2 *in vivo* and to expand upon the prior work^[2] following further optimization of the MR technique and the abscess model.

MATERIALS AND METHODS

The TTISS (T_1 and T_2 Interleaved for a Selected ^{19}F Spectrum) pulse sequence was allowed to measure four T_1 and four T_2 interleaved within twenty minutes in previous experiments. In this study TTISS pulse sequence was optimized by decreasing the TE to 16 ms by shortening gradients and RF pulses in order to increase ^{19}F signal. In previous studies the T_1 and T_2 were calculated from the echo data by using four different TRs and four different TEs respectively. In this study we used three different TRs and TEs to calculate T_1 and T_2 to increase the paired measurement from four to seven within the same sequence which increased time resolution. In addition, the integral area under the spin-echo was used in lieu of the peak amplitude to calculate the T_1 and T_2 values further increasing the signal-to-noise ratio.

In our prior study only one large abscess was created in each leg of the rabbit. For this study we choose to use four small abscesses, which had a total volume similar to the large abscess, increasing the ration of perflubron content in the wall to the center of abscess. These small abscesses were produced in the gastrocnemius muscle of both legs in 4 NZW rabbits. Two days following abscess inoculation rabbits were given 5 ml/kg (4.5g/kg) of perflubron emulsion (Oxygent® HT, Alliance Pharmaceutical Corp., San Diego). Rabbits were then scanned ten days following infusion. Prior to MR scanning an aortic occluder was placed around the aorta just distal to the renal arteries. Both legs of rabbits were placed within a 1H and ^{19}F double-tuned coil. The sequence to measure T_1 and T_2 relaxation of ^{19}F was initiated with each intervention. The sequence was acquired

while the rabbit breathed room air (20% O₂) and then again while breathing carbogen (95% O₂ + 5% CO₂). The 3rd sequence was acquired when rabbits were breathing carbogen but following the interruption of blood flow to the legs by totally occluding the abdominal aorta. The 4th sequence was acquired as the occluder was released initiating reperfusion.

The entire scanning time was one and a half hours and the total occlusion time was approximately 20 minutes. Following the MR procedure rabbits were sacrificed and the abscess wall and abscess center were analyzed for total perflubron content.

RESULTS

Figure 1 shows the changes of the relaxation rates $1/T_1$ and $1/T_2$ of ¹⁹F in the abscesses of two rabbits. These 2 rabbits displayed the largest and the smallest change observed of the four rabbits scanned, when the FIO₂ and blood flow were manipulated. Note the changes in $1/T_2$ were greater than those of $1/T_1$ indicative of T₂'s greater sensitivity to pO₂ changes. Although the results were similar for all rabbits the absolute values of these rates were different. We feel that the principle reason for this is due to the dampening effect of ¹⁹F signal originating from perflubron located in the abscess center which is avascular and does not experience the change in pO₂ experienced by perflubron in the abscess wall. Note that total perflubron content in the wall and the center was 39.7 to 19.2 for rabbit #1, and 8.4 to 17.6 for rabbit #2. Since the perflubron pool in the center of the abscess in rabbit #2 was double that in the wall, the change in ¹⁹F signal was dampened by a factor of 4 relative to rabbit #1 which contained twice as much perflubron in the abscess wall as it did in the abscess center.

To control for the variation in the ratio of PFC content between wall and center among rabbits, we analyzed the data by comparing the change in $1/T_1$ and $1/T_2$ following occlusion and reperfusion relative to the change observed when the FIO₂ was increased from 20 to 95%. We believe that this approach is reasonable since it is the same fraction of perflubron that would respond to changes in pO₂ with each intervention. This was calculated as $100 \cdot b/a$, where "a" was the change observed in $1/T_1$ or $1/T_2$ following carbogen breathing relative to their baseline room air value, and "b" the change observed after each of the subsequent interventions. Figure 2 shows the mean change of $1/T_2$ and $1/T_1$ for all four rabbits

**T₁ & T₂ Relaxation Rates
Measured from Leg Abscess of Rabbit #1**

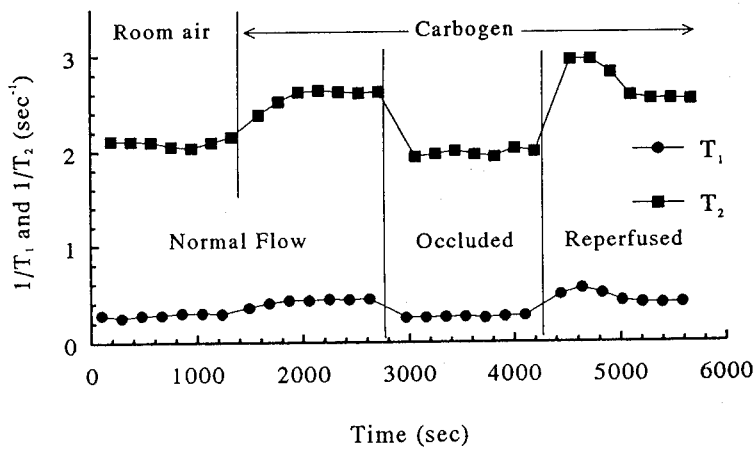

**T₁ & T₂ Relaxation Rates
Measured from Leg Abscess of Rabbit #2**

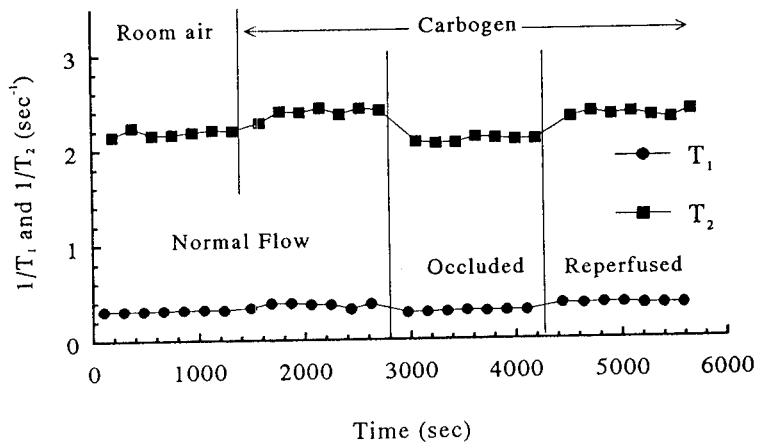

FIGURE 1: Variations in relaxation rates $1/T_1$ and $1/T_2$ of intracellular ^{19}F for different FIO_2 and arterial blood flow in rabbit #1 (above) and #2 (below) with high and low perflubron abscess wall to center concentration ratio respectively.

Change in Abscess Wall pO_2 Measured with T_1 & T_2 Rates

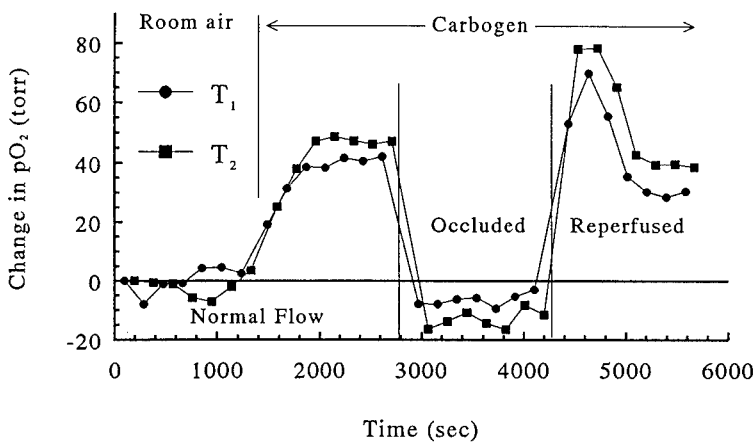

FIGURE 2: Mean change \pm SEM of pO_2 following each intervention relative to the change observed when the FIO_2 was increased from 20 to 95%. Bl=Baseline; Occ=Ocluded; Rep₁=Early reperfusion; Rep₂=Late reperfusion.

Change in T_1 & T_2 Rates Measured from Leg Abscesses

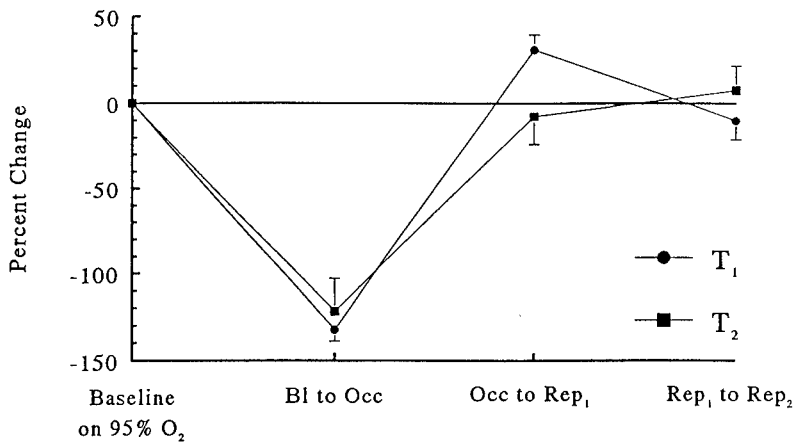

FIGURE 3: Change in pO_2 in the abscess of rabbit #1. The values were obtained by dividing the $1/T_1$ and $1/T_2$ measurements by their respective calibration slope.

following occlusion and 3 rabbits following reperfusion (balloon occluder failed to reopen in 1 rabbit) relative to the change observed from room air to carbogen breathing. The results in Figure 2 showed a relatively small standard error despite significant variations in the ratio of perflubron content in the abscess wall to abscess center.

Although the absolute pO_2 value calculated from T_1 and T_2 measurements is not known until validated by an independent technique, the change in pO_2 with each intervention is reliable because the linear correlation of $1/T_1$ and $1/T_2$ to pO_2 had an r -value of 0.999. When the $1/T_1$ and $1/T_2$ were converted to pO_2 , and the pO_2 changes calculated from $1/T_1$ and $1/T_2$ compared, the results were similar and consistent with each (Figure 3).

CONCLUSION

The results of this study proved that pO_2 monitoring by measuring the T_2 of ^{19}F is feasible and can be used in-lieu of the T_1 measurement. Given that the T_2 measurement is much more rapid than the T_1 measurement and that T_2 changes are more sensitive than T_1 changes with alterations in pO_2 , T_2 should prove to be practical and useful for monitoring transient rapid changes in pO_2 . Further, this model, when used to monitor pO_2 , is relatively insensitive to variations in the ratio of perflubron concentration in the abscess wall (vascular portion) vs. the abscess center (ischemic portion).

REFERENCES

1. Q Guo, P Tran, DJ Schumacher, et al. 10th SMRM 1991:1209.
2. Q Guo, RF Mattrey, C Guclu, et al. 11th SMRM 1992:14457.
3. JG Riess. *Int. J. of Artif. Org.* 14:255-258 (1991)
4. RF Mattrey, M Andre, J Campbell, et al. *Invest Radiol.* 19:438-446 (1984).

**NORMOTHERMIC PRESERVATION OF "MULTIPLE ORGAN
BLOCKS" WITH A NEW PERFLUOROOCXYL BROMIDE
EMULSION.**

EJ. Voiglio¹, L. Zarif², F. Gorry¹, MP. Krafft², J. Margonari¹,
JM. Dubernard¹, JG. Riess²

- 1) Laboratoire de Chirurgie Expérimentale et de Microchirurgie, INSERM U281,
Hôpital Edouard Herriot, Pav. P, 3 Place d'Arsonval, 69437
Lyon cedex 03, France.
- 2) Unité de Chimie Moléculaire, associée au CNRS, Université de Nice-Sophia
Antipolis, Parc Valrose, 06108 Nice cedex 02, France.

ABSTRACT

To evaluate the efficiency of fluorocarbon emulsions as oxygenating media for the normothermic preservation of organs (multiple organ blocks, MOB), a new perfluorooxyl bromide (perflubron) emulsion was compared with a mixture of modified Krebs solution and blood. The fluorocarbon emulsion used (90% w/v of fluorocarbon) contained a low amount of egg yolk phospholipid (EYP, 2% w/v) and was stabilized by a mixed fluorocarbon-hydrocarbon amphiphile C₆F₁₃C₁₀H₂₁ (F6H10). Blood of 4 rat MOBs was replaced with a 36% w/v fluorocarbon emulsion which had been complemented with albumin and electrolytes (EMOBs). 5 MOBs were perfused with a mixture of blood and albumin-containing Krebs solution (KBMOBs). Lactate, amylase and creatine kinase were lower (p<0.05) at 60 and 120 min in EMOBs than in KBMOBs,

showing lesser suffering of the organs. Diuresis was also higher ($p < 0.05$) in EMOBs (5.65 ± 1.76 vs 1.21 ± 0.28 mg/min). There was no difference in bile production, AST, ALT levels. Electrolytes and acid-base balance were preserved in all cases ; PaO₂ was significantly higher ($p < 0.05$) for the EMOBs than for the KBMOBs. It is concluded that fluorocarbon emulsions provide significant improvement in the normothermic preservation of organs.

INTRODUCTION

Cold storage is most commonly used for the preservation of organs for transplantation, but this method has a specific time limit beyond which the organ is no longer viable [1]. Continuous aerobic perfusion of the organs could be a worthwhile alternative to cold ischemic anaerobic preservation. We recently described the preservation at 37°C of Multiple Organ Blocks (MOB) removed from rats and perfused with a mixture of Krebs solution and blood [2]. A MOB is composed of "en bloc" removed heart-lungs, liver, pancreas, kidneys and bowel, connected by the vascular system, whose blood circulation is maintained by the heart, and oxygenation by the lungs under artificial ventilation. Unfortunately, hemolysis due to the continuous circulation in the external circuit occurred, limiting ex-vivo survival of the organs. This problem can be overcome by using a stable, inert, oxyphoretic liquid. Fluorocarbon emulsions could represent an effective answer to this challenge [3, 4]. We chose to study the preservation of all the organs likely to be transplanted in a single experimentation, in order to find a formulation suitable for the normothermic perfusion of all these organs. A new concept of emulsion stabilization has recently been developed which uses mixed fluorocarbon/hydrocarbon molecules, the so-called "molecular dowels" [5, 6]. The dowel molecule prevents the increase in particle size and allows a reduction of the amount of EYP required. Such a reduction is desirable as it diminishes the sedimentation phenomenon that occurred when bivalent ions, necessary for aerobic normothermic organ preservation, are added to the emulsion [7]. The object of this work was to compare the physiologic functions of rat MOBs perfused with a dowel-based perfluorooctyl bromide emulsion [8] with those of blood and Krebs solution-perfused MOBs. The results demonstrate improved preservation of 150 minutes fluorocarbon-perfused organs.

MATERIALS AND METHODS

Rats : 9 male Wistar rats (300-350 g, IFFA Credo, L'Arbresle, France) were used for procurement of MOB's ; 20 Wistar rats (> 400 g) for blood transfusions.

Removal of MOB's: MOB's were removed as previously described [2], and placed in a vaseline oil bath at 37°C (Figure 1).

Fluorocarbon emulsions : The emulsion consisted of 90 % w/v (i.e. 47 % v/v) perflubron (Hoescht), 2 % w/v of EYP (Asahi), an equimolecular amount of C₆F₁₃C₁₀H₂₁ (F6H10, 1.4 w/v), d-α tocopherol as an anti-oxidant, EDTA as a metal chelator (both to protect EYP against oxidation), a phosphate buffer and sodium chloride. The emulsion (1L size-batches) was prepared by microfluidization according to [8]. The physico-chemical parameters of the emulsion are presented in table I. The stem emulsion was diluted to 36 % w/v (Em. 1) and 18 % (Em 2) with a solution containing albumin and electrolytes (Table I).

Fluorocarbon emulsion-perfused MOB's (EMOB's) : The venous reservoir was filled with 40 ml of Em 1. The first 16 ml of blood which flowed into the arterial reservoir were discarded in order to let the emulsion replace blood. After this operation, the arterial reservoir was connected to the venous one, and the level of the venous reservoir was adjusted to 30 ± 5 ml with Em 2. A similar diluted emulsion was used during the entire experiment to avoid progressive concentration and subsequent increase in viscosity of the perfused liquid due to water evaporation in the lungs and hydric losses through diuresis and bile. The arterial liquid (4 ml) was sampled at 60, 90, 120 and 150 minutes.

Krebs and Blood-perfused MOB's (KBMOB's) : The venous reservoir was filled with 15 ml of Wistar rat blood and 10 ml of modified Krebs solution [2] Table I. The first 8 ml of blood which flowed into the arterial reservoir was discarded, the arterial reservoir was connected to the venous one, and the level of the venous reservoir was adjusted to 30 ± 5 ml with blood and modified Krebs solution (50 % v/v).

Function criteria : At 60, 90, 120 and 150 minutes, 4 ml of arterial liquid was sampled to measure electrolytes, proteins, AST, ALT, CK, amylase, lactate on a Kodak Ektachem 700 Analyser, pH, PaO₂, PaCO₂, HCO₃⁻ on a Ciba Corning 280. Urine and bile were collected, weighed, and the flows were calculated by

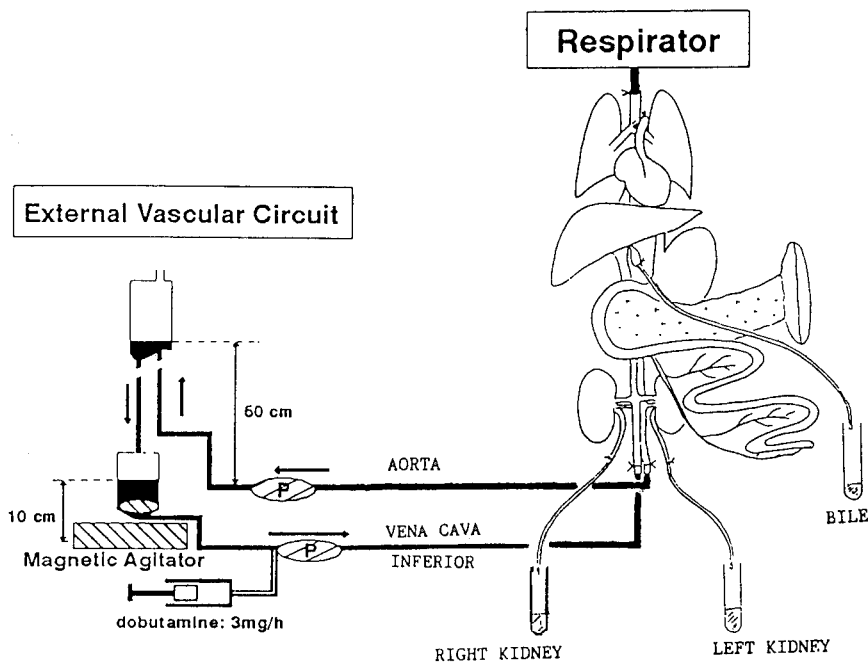

FIGURE 1 : Removed rat MOB : Bile duct and ureters were cannulated to collect bile and diuresis. Aorta and vena cava inferior were connected to the external vascular circuit : stabilized arterial and venous pressures were monitored. Lungs were ventilated by a pressure regulated respirator ($FiO_2 = 100\%$, Peak P = 12mmHg, Mean P = 5mmHg, PEEP = 2mmHg, Frequency = 45/min).

dividing the weight by the preservation time of the MOB. Results were expressed as mean \pm SEM, Student's t test was performed. Arterial pressure was continuously monitored (Sirecust 302D, Siemens, Germany).

RESULTS AND DISCUSSION

Hemodynamics were stable during the observation period (60-150 min). There was no difference between the perfusion rates of EMOBs and KBMOBs (0.42 ± 0.038 vs 0.40 ± 0.026 ml/min). Electrolyte and acid-base balances were preserved during the observation period (60-150 min). Amylase and CK were significantly

TABLE I : Formulation and characteristics of emulsions used in EMOBs perfusion and modified Krebs' solution used in KBMOBs

Composition	Stem emulsion 90 % w/v	Em. 1 36 % w/v	Em. 2 18 % w/v	Krebs solution
perflubron (g)	90	36	18	-
F6H10 (g)	1.4	0.56	0.28	-
EYP (g)	2	0.8	0.4	-
d- -tocopherol (g)	0.002	0.0008	0.0004	-
Na (mM)	18.6	132	135	134
K (mM)	-	3.9	4	2.7
Cl (mM)	26	95	100	95
HCO ₃ (mM)	-	18	18	22
Prot. (g/l)	-	26	26	71
Ca (mM)	-	0.6	1.5	2.96
HPO ₄ (mM)	-	14	3.7	0
pH	7.2	7.40	7.50	7.6
Viscosity coeff.	9 cp	-	-	0
ø Post steril.	0.20 µm	-	-	-

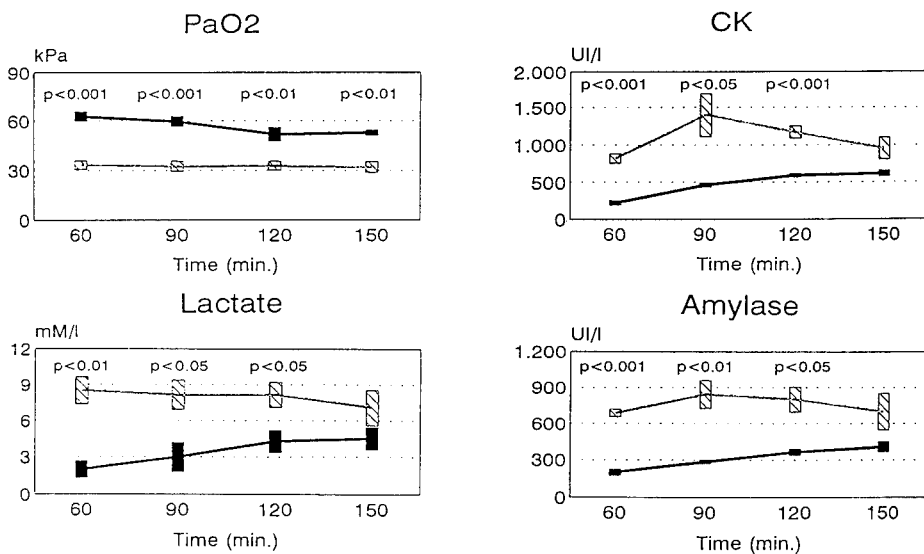

FIGURE 2 : PaO₂, CK, Lactate and Amylase in EMOBs (■) and KBMOBs (▨).

lower in EMOBs, showing less deterioration of pancreases and of hearts perfused with the new perflubron emulsion (figure 2). AST and ALT levels were comparable in EMOBs and in KBMOBs. Hematosis was better with the perflubron emulsion, as demonstrated by lower lactate levels and significantly higher PaO₂ values. The perflubron emulsion allowed full aerobic metabolism to be maintained in the organs. Diuresis was higher ($p < 0.05$) in EMOBs (5.61 ± 1.76 vs 1.21 ± 0.28 mg/min), evidencing better preservation of the emulsion-perfused kidney. There was no difference in bile production. Histologic examination of the organs perfused with perflubron showed no severe lesions ; additional analysis by optical and electronic microscopy is in progress.

By using the MOBs model, we have demonstrated that a perflubron/F6H10/EYP emulsion allows better normothermic aerobic preservation of perfused organs for 150 minutes than a 50% v/v blood and Krebs mixture. As oxygen is simply dissolved in the fluorocarbon emulsion and not chemically bound as in hemoglobin [9], oxygenation of the organs is possible even at low temperatures. Work is underway to determine if survival of ex-vivo MOBs will be improved by decreasing the temperature. Since continuous aerobic preservation is theoretically one means of obtaining truly long term preservation [1], and since recent fluorocarbon emulsions seem to be the best way of aerobic perfusion of organs [10, 11], more research is warranted in this field.

ACKNOWLEDGEMENTS : We wish to thank the Centre National de la Recherche Scientifique, Applications et Transferts de Technologies Avancées, Prix Antonin Poncet (Université de Claude Bernard de Lyon), and Hospices civils de Lyon for financial support, as well as Dr Trepo, Dr M.C. Penes and the team of the laboratoire de Biochimie de l'hôpital Edouard Herriot de Lyon.

REFERENCES

- [1] F.O. Belzer, JH. Southard, *Transplantation*, 45: 673-676 (1988)
- [2] E.J. Voiglio, F. Gorry, J. Margonari, J.L. Faure, *Chirurgie*, 116: 690-698 (1990).
- [3] N. Kamada, R.Y. Calne, D.G. Wight, J.G. Lines, *Transplantation*, 30, 1 : 43-48 (1980)
- [4] S. Fuchinoue, K. Takahashi, S. Teraoka, H. Toma, T. Ahishi, K. Ota, *Transplant Proc*, 18, 3: 566-570 (1986)
- [5] J.G. Riess, L. Sole Violan, M. Postel : *J. Disp. Sci. Technol.*, 13:349 (1992)

- [6] J.G. Riess, M. Postel, *Biomat., Art. Cells, Immob. Biotech.*, 20 : 819-830 (1992)
- [7] F. Puisieux, J. Delattre : *Les liposomes, applications thérapeutiques*, TEC, (1989)
- [8] J.G. Riess, C. Cornelus, R. Follana, M.P. Krafft, A.M. Mahé, M. Postel, L. Zarif, In *Oxygen Transport to Tissues* xxxx (1993)
- [9] J.G. Riess, *Vox. Sang.* , 61 : 225-239 (1991)
- [10] L.D. Segel, J.M. Minten, F.K. Schweighardt, *Am. J. Physiol.* 263(Heart Circ. Physiol. 32) H730-H739 (1992)
- [11] J.G. Riess. Overview on Progress in the Fluorocarbon Approach to *in vivo* Oxygen Delivery. In: *Blood Substitutes and Oxygen Carriers*, Chang TMS (ed), M. Dekker, New York, 24-43 (1993).

ORGAN PRESERVATION WITHOUT EXTREME HYPOTHERMIA USING AN
OXYGENT™ SUPPLEMENTED PERFUSATE

L. Brasile, P. DelVecchio, K. Amyot, C. Haisch, and
J. Clarke; VEC TEC, Inc., Schenectady, NY; Albany Medical
College, Albany, NY; and East Carolina University,
Greenville, NC, USA

Abstract: All methods of organ preservation depend upon hypothermia to depress metabolism during storage. Yet, hypothermia may represent the rate-limiting factor in organ preservation. A new perfusate has been developed which supports organ preservation without extreme hypothermia. The perfusate consists of a complex fluid supplemented with an oxygen carrying perfluorocarbon emulsion, Oxygent™ (Alliance Pharmaceutical Corp,). The perfusate was used to preserve canine kidney autografts using pulsatile preservation at 32°C and static storage at 25°C. Upon autografting the dogs produced urine within minutes of reperfusion. These results indicate the new perfusate may have significant potential in organ preservation without extreme hypothermia.

INTRODUCTION

Early attempts at preserving kidneys demonstrated that warm ischemia (WI) leads to tubule damage and obstruction of the vasculature.[1,2,3,4] Hypothermic conditions have been utilized in organ preservation, since it was demonstrated that hypothermia reduced the kidneys demand for O₂ and nutrients by reducing the metabolic rate.[5] The O₂ consumption is reduced by more than 95% at 4°C[6,7] and most enzyme systems experience a two-fold

decrease in activity for every 10°C that the temperature is decreased.[8]

However, the effect of hypothermia on a graft is not benign. Cold-induced damage results in edema, loss of barrier function, acute tubular necrosis, vasospasm and intracellular acidosis.[9] The hypothermic conditions may actually represent the rate-limiting factor in organ preservation. All perfusates used clinically have been formulated to minimize cold-induced organ damage.

We evaluated if an Oxygent™, a perflubron emulsion(perfluorooctyl bromide, PFOB) supplemented perfusate could be used to preserve canine kidneys at a temperature range of 25-32°C.

MATERIALS AND METHODS

Canine Kidneys - The left kidneys from five dogs were nephrectomized via a midline incision. The renal arteries were cannulated and the kidneys were flushed with the Oxygent supplemented perfusate (20% v/v). The basal perfusate consisted of a complex formula containing more than 60 ingredients, including amino acids, carbohydrates, colloids, growth factor and plasma proteins. Prior to reimplantation, the intrinsic kidney from each dog was nephrectomized.

In Vitro Kidney Preservation - A total of four kidneys were preserved with pulsatile perfusion at pressures averaging 62mmHg. Kidneys from two dogs were preserved in the new perfusate at 32°C for four and seven hours of WI, respectively. Controls consisted of a kidney stored in Oxygent in saline (20% v/v) and one preserved in the basal perfusate without Oxygent at 32°C for four hours. Flow rates were in the range of 60-100cc per minute

throughout the period of preservation. The fifth kidney was flushed and then stored submerged in an airtight container filled with the Oxygent supplemented perfusate at 25°C for four hours.

Autotransplantation - The kidneys were autotransplanted on the abdominal aorta and inferior vena cava of the dog. The vascular reconstruction consisted of an end to side anastomosis of the renal artery to the aorta and the renal vein to the vena cava.

RESULTS

Preservation Characteristics - Both kidneys pumped in the Oxygent supplemented perfusate, demonstrated good preservation parameters; including stable pressures and flow rates. The flow dynamics were comparable in the two kidneys preserved in the Oxygent supplemented perfusate for the two time points, namely four & seven hours at 32°C (Table I). No edema was detected.

The control kidney, preserved in the basal perfusate without Oxygent demonstrated similar flow characteristics. However, this kidney developed a splotchy appearance. The control kidney preserved in a solution consisting of Oxygent in saline demonstrated poor flow dynamics and substantial edema after two hours of preservation (Table I). Due to the poor flow dynamics and the edema, the control kidney in Oxygent plus saline solution could not be transplanted.

Autotransplantation - All four dogs produced urine within minutes of reperfusion, exhibiting normal turgor and pulse. However, the three kidneys preserved with the Oxygent supplemented perfusate demonstrated superior reperfusion. The dogs continued to produce urine

TABLE I - PUMPED KIDNEYS

<u>Dog</u>	<u>Perfusate</u>	<u>Storage</u>	<u>IVR*</u>	<u>Histology</u>
1	+ Oxygent	4hrs.	3.04	Normal
2	+ Oxygent	7hrs.	3.00	Normal
3	Basal Alone	4hrs.	5.08	Infiltration-PMN's
4	Oxygent+Saline	4hrs.	0.32	Glomeruli Damage/ Edema

*IVR - Intrarenal Resistance = $\frac{\text{Mean Pressure}}{\text{Mean Flow Rate}}$

throughout the posttransplant period. At 24 hours all four dogs exhibited elevated serum creatinine values (Figure 1). In the three dogs autotransplanted with a kidney preserved in the Oxygent supplemented perfusate, this rise in serum creatinine was transient. The serum creatinine values in these three dogs returned to near preoperative values and the respective dogs were euthanized once the function of the kidneys was established. In the dog autotransplanted with the kidney preserved with perfusate lacking Oxygent supplementation, the creatinine continued to rise. On day four, the dog was euthanized when the serum creatinine level was greater than 8.0 mg/dL.

Histology - The control kidney stored in Oxygent in saline and not transplanted due to unacceptable flow characteristics, demonstrated dilated glomerular capillaries, dilated blood vessels as well as interstitial edema upon histologic evaluation. The second control kidney preserved in the basal perfusate without Oxygent, was found to have a wide band of interstitial infiltration of PMN in the cortex, indicative of a reperfusion injury.

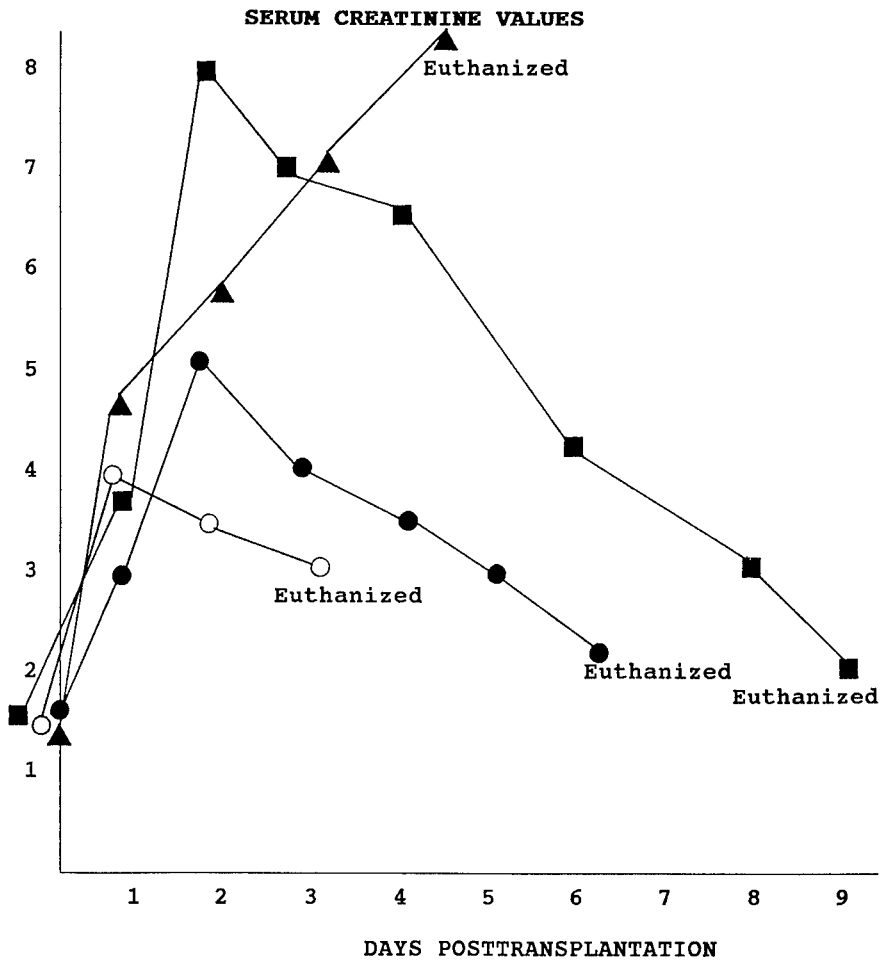

Figure 1

- Oxygen supplemented perfusate for 4 hours - simple static storage
- Oxygen supplemented perfusate for 4 hours
- Oxygen supplemented perfusate for 7 hours
- ▲ Basal perfusate alone

The kidneys preserved in the Oxygent supplemented perfusate were found to be overall, well preserved without evidence of PMN infiltration. The Oxygent supplemented perfusate appeared to provide better preservation in that there was no evidence of reperfusion injury, superior reperfusion was observed and better postoperative serum chemistries were demonstrated.

DISCUSSION

The results of this preliminary study, suggest that organ preservation without extreme hypothermia is feasible. The new perfusate has been formulated to support the metabolism of a whole organ, rather than to diminish or control the detrimental effects of hypothermia. The kidneys preserved in this new perfusate did not develop vasospasm, edema or severe tubular necrosis.

The benefits of warmer temperature [18-32°C] organ preservation are substantial. The membrane phospholipids would be in a more normal fluid state and would facilitate the uptake and transport of available oxygen across the membrane. We believe the further development of this technology may present the opportunity to provide organ preservation with metabolic support.

REFERENCES

- 1) N.S. Frega, D.R. DiBona, B. Gaerther and A. Leaf: *Kidney Int* 10:17, (1976)
- 2) E.E. Selkurt and M.J. Elpers: *Amer J Phys* 205:147, (1963)
- 3) J.D. Conger, J.B. Robinette and R.W. Schrier: *J Clin Invest* 82:532, (1988)
- 4) H.L. Sheehan and J.C. Davis: *J Path Bact* 78:105, (1959)
- 5) R.J. Bickford and F.R. Winton: *J Phys* 89:198, (1937)
- 6) M. Levy: *Am J Phys* 197:1111, (1959)
- 7) F.A. Fuhrman: *In the Physiology of Induced Hypothermia*, Pub 451, Natl Acad Sci-Nat Res Council: Washington, (1956), pg 50
- 8) R.A. Zager, D.J. Gmur, C.R. Bredl and M.J. Eng: *Cir Res* 65:1263, (1989)
- 9) P.W. Hochachka and T.P. Mommsen: *Science* 219:1391, (1983)

POSTMORTEM ORGAN SALVAGE USING AN OXYGENT™ SUPPLEMENTED
PERFUSATE

L. Brasile, P. DelVecchio, U. Rudofsky, C. Haisch, and
J. Clarke; VEC TEC, Inc. Schenectady, New York; Albany
Medical College Albany, New York; New York State Kidney
Disease Institute, Albany, New York; and East Carolina
University, Greenville, North Carolina, U.S.A.

Abstract: The world-wide shortage of organs for clinical transplantation is caused by the limited existing donor pool of heartbeating cadavers. Attempts to expand into the nonheartbeating cadaver population have been hindered by warm ischemic damage. We evaluated if a new Oxygent™ (Alliance Pharmaceutical Corp.) supplemented perfusate could be used to salvage canine kidneys postmortem. The kidneys preserved in the Oxygent perfusate could be maintained in situ for time points ranging from one - eight hours postmortem; enough time to declare death and obtain consent for organ donation. In contrast, the control kidneys yielded abnormal histologic findings and impaired flow dynamics. These results suggest the new perfusate may have significant potential to expand the existing organ donor pool.

INTRODUCTION

The most limiting factor today in organ transplantation is the shortage of organs.[1] The shortage of organs can be attributed to the limited donor pool consisting of heartbeating cadavers (HBCD). A HBCD is brain dead while

being maintained on life support systems. HBCD represent a small fraction of the traumatic death population.

The ability to procure organs from nonheartbeating cadavers (NHBCD) could increase the supply by as much as ten-fold.[2] Patients who die at the site of an accident or who have a short post-injury survival cannot be used routinely as organ donors.[3,4] Current approaches used to expand into the NHBCD population have focused on patients who succumb in a hospital setting within a few minutes of death.[5,6] Until the damaging effects of warm ischemia can be alleviated the donor pool cannot be substantially expanded.

We, therefore, evaluated if an Oxygent™, a perflubron emulsion (perfluorooctyl bromide, PFOB) supplemented perfusate could be used postmortem to salvage organs and to preserve them in situ for a period of time long enough to obtain consent from next of kin.

MATERIALS AND METHODS

Kidney Dissections - Conditioned mongrel dogs were euthanized by lethal injection. After warm ischemic times ranging from 15 to 45 minutes, a mid-line incision was made and a cannula was placed in the aorta above the left renal artery. A second cannula was placed in the vena cava above the right renal vein. The aorta and vena cava were crossed clamped below the kidneys.

In situ flushing - The perfusate consisted of more than 60 ingredients, including: amino acids, carbohydrates, colloids, lipid, growth factor and plasma proteins which was supplemented with 20% (v/v) Oxygent. Approximately 250cc of the perfusate, warmed to 32°C, was used to flush the kidneys in 10 dogs. The kidneys were stored in situ

without artificial cooling for time periods ranging from one to eight hours postmortem, without recirculation. All testing was performed in duplicate. Kidneys receiving no treatment and kidneys stored in ViaSpan™ at 4°C were used as controls.

In Vitro Preservation - The kidneys were further preserved in vitro to determine viability. The kidney's were perfused with the Oxygent supplemented perfusate at 32° on the MOX-100 preservation system for an additional three hours. The kidneys were fixed in formaldehyde and sectioned for blinded histologic evaluation.

RESULTS

Kidneys Preserved in the Oxygent Supplemented Perfusate

All kidneys stored in situ with the Oxygent supplemented perfusate could be reflushed and pumped (Table I). Even 30 - 45 minutes of warm ischemia, followed by in situ preservation, provided acceptable flow dynamics. The histologic findings indicated the kidneys were well preserved with intact microvessels.

Control Kidneys

1. No Treatment - The kidneys experiencing 60 minutes of warm ischemia without treatment, demonstrated focal dilated capillaries, Bowman's spaces and tubules (Table II). Interstitial edema was found in all parts of the tubules. At two hours of warm ischemia, the vasculature was occluded (Table II). The histological findings indicated extensive glomerular damage in the cortex of the kidney along with tubular necrosis throughout the medulla.

2. ViaSpan™ Preserved Kidneys - These control kidneys provided a base line of state-of-the-art preservation.

Table I - Test Kidneys

<u>In Situ</u>	<u>IVR*</u>	<u>Histology</u>
1hr	OT= 4.3, 1hr=5.2 2hr=5.3, 3hr=5.3	Normal
2hr	OT= 1.3, 1hr=0.8 2hr=0.9, 3hr=1.1	Normal
3hr (30'WI)	OT= 4.8, 1hr=3.6 2hr=2.4, 3hr=2.4	Normal glomeruli, slight tubular dilation
5hr	OT= 4.8, 1hr=1.7 2hr=1.7, 3hr=1.9	Normal
8hr	OT= 1.7, 1hr=5.5 2hr=4.5, 3hr=4.5	Normal glomeruli, vacuoles in straight tubules

*IVR-Intrarenal Resistance= $\frac{\text{Mean Pressure}}{\text{Mean Flow Rate}}$

Table II - Control Kidneys

<u>Method</u>	<u>IVR*</u>	<u>Histology</u>
Postmortem(1hr) (No Treatment)	5.0	Dilated glomeruli & tubules, interstitial edema
Postmortem(2hr) (No Treatment)	Occluded	Glomerular swelling, tubular karyolysis
ViaSpan™	OT= 15, 1hr=5.8 2hr=6.0, 3hr=6.2	Dilated tubules, edema
ViaSpan™ (3hr in situ)	No Flow	Hypercellular glomeruli & tubules

*IVR - Intrarenal Resistance= $\frac{\text{Mean Pressure}}{\text{Mean Flow Rate}}$

However, even in the kidneys with no warm ischemia the histologic findings identified dilated tubules along with focal edema within the medulla of the kidney (Table II). Tubule damage is a common side effect in the hypothermic preservation of kidneys.

When ViaSpan at 4°C was used as a control for the in situ preservation experiments very different results were obtained. The flow dynamics were unacceptable with pressures, which could not be regulated, in excess of 140mmHg. The histologic findings from these kidneys indicated extensive glomerular damage along with severe tubule damage throughout the kidneys (Table II).

DISCUSSION

The damaging effects of warm ischemia have been discussed in many studies.[3,4,7,8,9,10,11] Warm ischemia represents the major obstacle in expanding the organ donor pool into the NHBCD population. The new Oxygent supplemented perfusate was used to preserve kidneys in situ for time periods up to eight hours postmortem. Eight hours of in situ preservation represents a reasonable time frame to obtain consent from next-of-kin for organ donation. The histological findings indicated the kidneys were well preserved with normal glomeruli throughout the period of in situ preservation. The only tubular damage detected was vacuoles which did not develop in the kidneys until almost of eight hours of in situ preservation.

In contrast, the control kidneys yielded abnormal histologic findings. Kidneys stored in situ with cold ViaSpan for three hours at 4°C could not be adequately perfused, demonstrating unacceptable flow dynamics, after in situ preservation.

A contributing factor in the successful in situ preservation may have been the absence of severe hypothermia. While hypothermia diminishes the metabolic rate and oxygen consumption in a preserved allograft, cold-induced damage also leads to vasospasm, alterations in permeability and tubular necrosis.[12,13,14,15] The ability to maintain the kidney after a period of warm ischemia, without using extreme hypothermia, may present the opportunity to expand the organ donor pool into the NHBCD population, if in situ flushing could be instituted within the first hour of postmortem. The results of these preliminary studies suggest that an Oxygent supplemented perfusate may have significant potential for expanding the existing organ donor pool into the NHBCD population.

REFERENCES

- 1) Annual Report of the U.S. Scientific Registry for Organ Transplantation and the Organ Procurement and Transplantation Network, (1990). UNOS, Richmond, VA and the Div of Organ Transplantation, Health Resources and Services Administration, Bethesda, MD
- 2) D. Anaise, R. Smith, M. Ishimru, et al: *Transpl* 49:290, (1990)
- 3) J.H. Southard: In *Clinical Ischemic Syndromes Mechanisms and Consequences of Tissue Injury* (ed. GB Zelenok), St. Louis, Mosby, pg 303, (1990)
- 4) D.E. Pegg, M.C. Wusteman and J. Foreman: *Transpl* 32:437, (1981)
- 5) S. Fuchinove, K. Takahashi, S. Teraoka et al: *Transpl Proc* 18:566, 1986
- 6) D. Anaise, R. Smith, M. Ishimaru et al: *Transpl* 49:290, 1990
- 7) R.I. Weed, P.L. LaCelle and E.W. Merrill: *J Clin Invest* 48:795, (1969)
- 8) H.L. Sheehan and J.C. Davis: *J Path Bacteriol* 78:105, (1959)
- 9) M. Brezis, S. Rosen, P. Silva and F.H. Epstein: *Kidney Int* 26:375, (1984)
- 10) J.I. Cho, B.P. Zaineraitis, C. Franklin et al: *Transpl Proc* 17:16, (1985)

- 11) N.S. Frega, D.R. DiBona, B. Gaerther and A. Leaf:
Kidney Int 10:17, (1976)
- 12) J. Mason, F. Beck, A. Dorger et al: Kidney Int
20:61, (1981)
- 13) A. Leaf: Ann NY Acad Sci 172:33, (1970)
- 14) R.I. Jamison: West J Med 120:205, (1974)
- 15) J. Flores: J Clin Invest 51:118, (1972)

**REDUCING MAGNETIC SUSCEPTIBILITY DIFFERENCES
USING LIQUID FLUOROCARBON PADS (SAT PAD™):
RESULTS WITH SPECTRAL PRESATURATION OF FAT.**

Steve S. Eilenberg¹, M.D., V. Marie Tartar¹, M.D.,
and Robert F. Mattrey², M.D.

Tri-City Medical Center (1), Oceanside, CA 92056 and MRI Institute (2),
University of California San Diego Medical Center, 410 Dickinson St, San Diego,
CA 92103.

ABSTRACT

Although the magnetic field may be homogeneous, the positioning of a human subject in the bore of the magnet to perform imaging studies induces inhomogeneous fields. Least effect is generated when the object is cylindrical. In regions of marked contour abnormalities such as the leg to foot junction and trunk to neck or neck to head, the inhomogeneity can be so dramatic that errors in fat saturation occur that can lead to misdiagnoses.

This manuscript is intended to explain the principle of magnetic susceptibility, fat saturation, and how Sat Pads help improve magnetic field homogeneity. The improved homogeneity results in higher quality MR images, improved homogeneous fat/water saturation to allow for true anatomic representation.

Magnetic Resonance (MR) imaging is a modality that utilizes a magnetic field and radio-waves to interact with hydrogen atoms (protons) inside the body to create non-invasive sectional images of internal organs [1]. The basic and most important principle upon which this technique relies is that protons will respond to a specific radio-frequency dependent upon the local magnetic field strength they experience. Therefore, to properly interact with specific protons, their local magnetic field must be homogeneous and known. When a linearly ramped

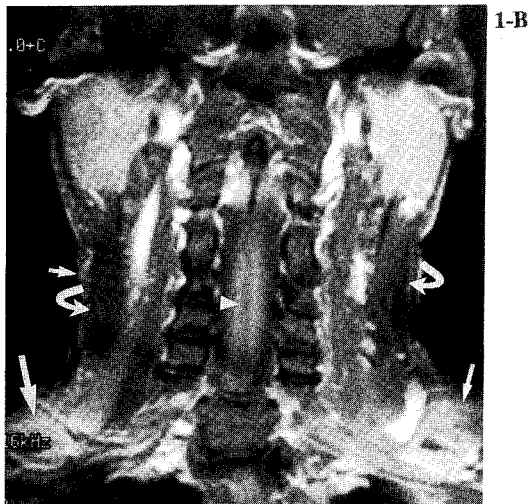
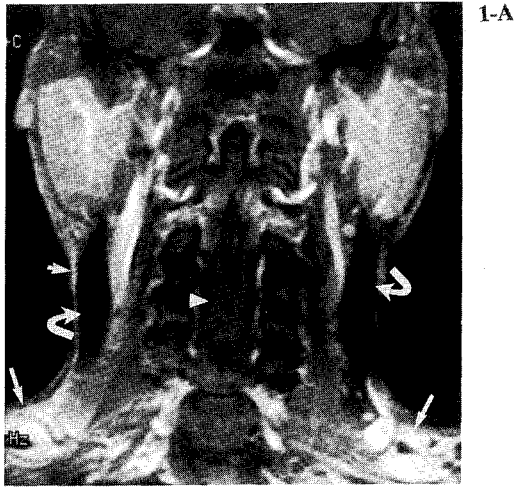

FIGURE 1: Coronal slices at the level of the spinal canal was obtained with fat-suppression prior to (A) and following (B) the placement of the ankle Sat Pad using the identical scanning techniques. Note the regions of failed fat-suppression (arrows in (A)) that became suppressed when the Sat Pad was in place (arrows in (B)). More importantly, without the Sat Pad, inappropriate water suppression of the sternocleidomastoid muscle occurred (curved arrows in (A)) because of the inhomogeneity in the field at the sides of the neck. The spinal cord was also inappropriately suppressed (arrowhead in (A)) because of the air at the back of the neck. These areas of incomplete or inappropriate suppression were corrected when the Sat Pad was in place.

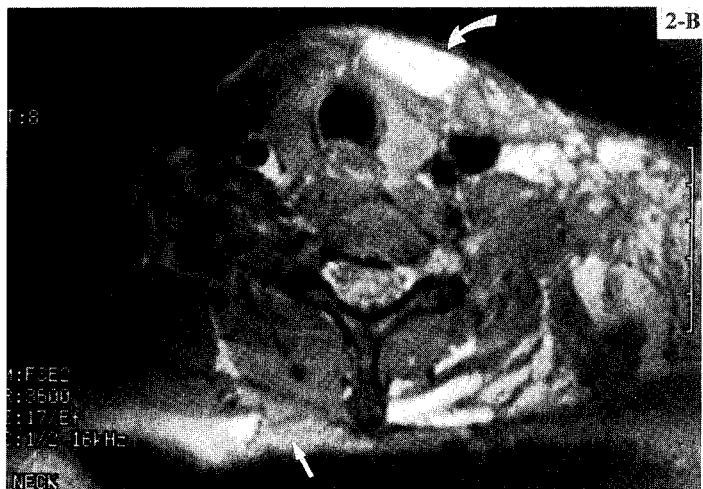
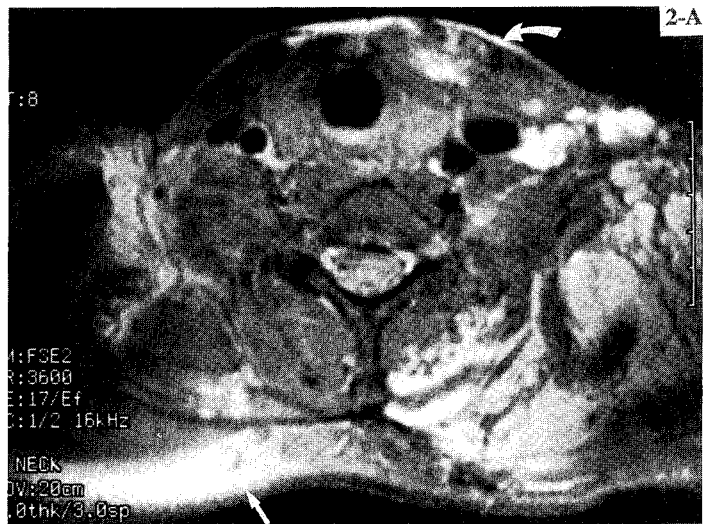

FIGURE 2: Axial scans obtained at the level of a hemangioma in the neck with fat-suppression prior to (A) and following (B) the placement of the ankle Sat Pad using the identical scanning techniques. Note the regions of failed fat-suppression (arrows in (A)) that became suppressed when the Sat Pad was in place (arrows in (B)). More importantly, without the Sat Pad, mild but inappropriate water suppression in the regions of the mass nearly eliminated its signal (curved arrow in (A)). The mass became more apparent with the Sat Pad in place (curved arrow in (B)) because the field became more homogeneous eliminating inappropriate water suppression.



FIGURE 3: Axial scans were obtained at level of the mid calcaneus in a patient with foot pain using fat-suppression prior to (A) and following (B) the placement of the ankle Sat Pad using the identical scanning techniques. Note the regions of failed fat-suppression (arrows in (A)) which became uniformly suppressed with the Sat Pad in place (arrows in (B)). More importantly, note that inappropriate water suppression caused the swelling in the ligaments (curved arrows in (A)) to appear dark and more difficult to detect. When the field was made more homogeneous with the Sat Pad, complete and appropriate suppression occurred allowing the detection of the swollen ligaments (curved arrows in (B)).

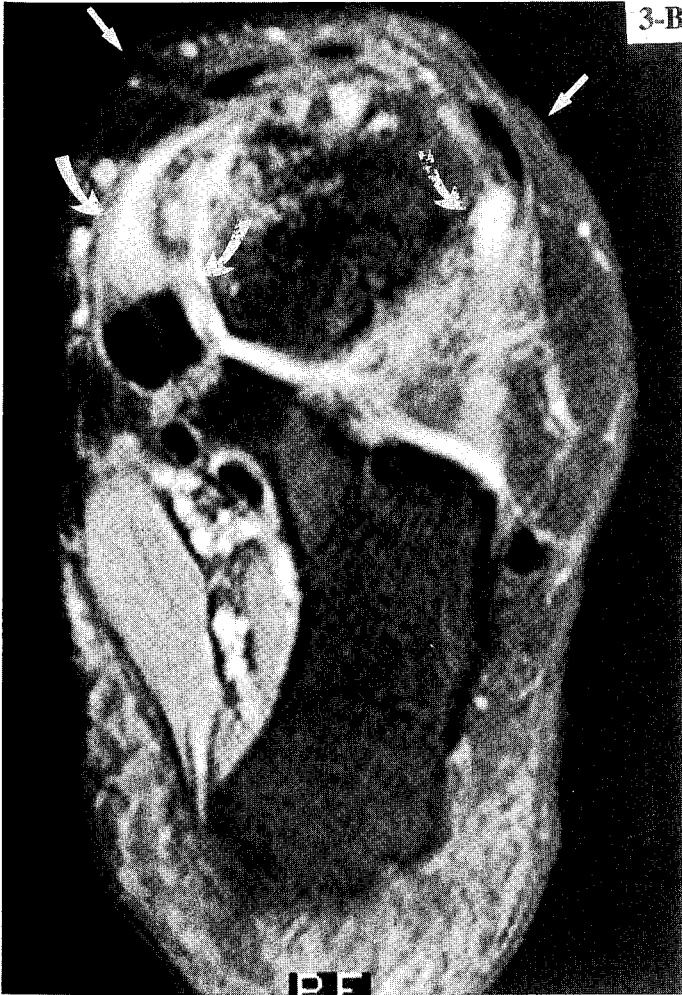

FIGURE 3: Continued

magnetic field is applied, (weaker at one end than the other), specific protons can be selected by delivering a radio-frequency wave containing frequencies at which the protons of interest are resonating [2]. If the magnetic field is not uniform, errors occur.

The 2 most important populations of protons in the body are those of water and those of fat. Despite the fact that a fat and water molecule may experience the same local magnetic field strength, fat protons will respond to a slightly different frequency than those of water because of minor interference within the molecule. It is possible through specialized imaging schemes to suppress signal from the fat or the water protons to produce a water or a fat image. Because cancerous and inflammatory lesions contain a relatively larger amount of water, a fat-suppressed image (water image), increases their conspicuity. Because fat is bright and because abnormal tissues brighten significantly following IV contrast injection, fat-suppression techniques become even more important [3,4]. It is for these reasons that fat-suppression has become part of the standard MR study.

Efficient fat-suppression, which is achieved by delivering a radio-wave at the fat proton resonant frequency, should decrease the fat signal uniformly throughout the slice. Should the magnetic field be inhomogeneous within the slice, fat protons would resonate at slightly different frequencies causing the radio-frequency pulse to affect some protons and not others. Regional failures leave fat unsuppressed which remains bright leading to misinterpretation. More importantly, the radio-frequency pulse that missed the fat proton could in fact strike the water proton to erroneously suppress water, causing further confusion. Given the importance of the fat suppression in clinical practice, more stringent requirements have been placed to perfect the uniformity of the magnetic field.

Magnetic forces (flux lines) in a cylindrical magnet travel from one end of the cylinder to the other through the path of least resistance. In an empty homogeneous magnet the flux lines remain parallel generating a uniform magnetic field. Because tissues conduct magnetic flux differently than air (different magnetic susceptibility), when a subject is placed within the magnet, the field becomes inhomogeneous [5]. This is because the flux lines, preferring to travel through tissues, converge to the tissue away from air causing a magnetic field gradient at the skin/air interface and therefore regional magnetic field inhomogeneity within a selected slice. Where the body is cylindrical the magnetic gradient at the skin is minimal and where it is irregular the gradient can become significant and can reach greater depth within the tissue. Areas of dramatic variation in contour exist in the

body such as the neck and head region, neck and trunk, leg and foot, etc. which induce gradients and cause misregistration and more importantly non-uniform fat suppression [6].

Neat PFCs have a susceptibility similar to tissues. When tissues are bathed in PFC, no magnetic gradient develops at the tissue/PFC interface but a gradient would exist at the PFC/air interface. Thus the PFC liquid serves to displace the gradient away from the skin and the region of interest. Although a similar effect can be produced by water, because PFC liquids do not contain protons, PFCs emit no signal remaining invisible. Because it is impractical to submerge body parts in liquid PFCs, pads filled with PFC (Sat Pad™, Alliance Pharmaceutical Corp., San Diego, CA) have been designed to contour these irregular regions.

REFERENCES

1. GL Wolf, C Popp. *NMR: A Primer For Medical Imaging*. GL Wolf, C Popp eds. SLACK Inc, Thorofare, N.J. (1984)
2. A Haase et al. H1 NMR Chemical Shift Selective (CHESS) Imaging. *Phys Med Biol* 30:341 (1985)
3. RD Tien et al. Improved Detection and Delineation of Head and Neck Lesions with Fat Suppression Spin-echo MR Imaging. *AJNR* 12:19 (1991)
4. RD Tien et al. Intra- and Paraorbital Lesions: Value of Fat-suppression MR Imaging with Paramagnetic Contrast Enhancement. *AJNR* 12:245 (1991)
5. FW Wherli et al. The Inhomogeneity of Magnetic Susceptibility in Vertebral Body Marrow. *Proc Soc Magn Reson Med*, Amsterdam (1989)
6. BW Dick et al. The Effect of Chemical Shift Misrepresentation on Cortical Bone Thickness on MR Imaging. *AJR* 151:537 (1988)

**DOUBLE-TAILED PERFLUOROALKYLATED GLYCOLIPIDS AS
COMPONENTS FOR DRUG DELIVERY AND TARGETING
SYSTEMS. PRELIMINARY BIOCOMPATIBILITY RESULTS**

L. Zarif ¹, J.G. Riess ¹, B. Pucci ², C. Guedj ², A.A. Pavia ²

¹ *Unité de Chimie Moléculaire, associée au CNRS, Université de Nice-Sophia
Antipolis, 06108 Nice cedex 02, France*

² *Laboratoire de Chimie Bioorganique, Faculté des Sciences, 33 Rue Louis
Pasteur, 84000 Avignon, France.*

ABSTRACT

Vesicles are being investigated as drug carriers, especially for enhancing the therapeutic effectiveness of the drug while minimizing its side effects. Drug targeting can be achieved if there is a specific recognition of the vesicle's outer wall by specific cells. With these objectives in mind new glycolipids fitted with fluorinated, hydrogenated or mixed, single and double-tails, containing either a gluco- or a galactopyranose residue in their hydrophilic head, were synthesized and their ability to achieve self-organized supramolecular systems was assessed. Replacement of hydrogen by fluorine in these glycolipids was found to enhance biological tolerance. Thus, a fluorinated single-tailed glycolipid displayed no action on red blood cells at concentrations as high as 50 g/l while its hydrogenated analog was hemolytic at 5 g/l. 100% of survival was obtained one month after intravenous or intraperitoneal injection into mice of isotonic dispersions of single and double-tailed glycolipids at a dose of 500mg/kg. These glycolipids were innocuous on Namalva cell cultures at a concentration of 0.1 g/l.

INTRODUCTION

Amphiphiles with perfluorinated tails have potential as components of drug delivering and targeting systems [1]. Such amphiphiles, when they have two perfluoroalkylated hydrophobic tails were shown to form vesicles and other organized supramolecular assemblies [2, 3]. Even single perfluoroalkylated chain amphiphiles were recently shown to readily form vesicles [4]. Vesicles made from perfluoroalkylated materials tend to be more stable than those made of hydrogenated analogs [5]. Conceptually, the presence of a fluorinated hydrophobic and lipophobic termination allows the building of an impermeable fluorinated film within the membrane double-layer. This was indeed shown to result in lesser permeability of the membrane to a lipophilic probe [3]. A large variety of well defined fluorinated amphiphiles have been synthesized and evaluated for the purpose of serving as emulsion stabilizers as well as membrane components and modifiers [6]. Moreover, such amphiphiles can be fitted with residues that allow the recognition of the vesicles by receptors of specific tissues for the purpose of drug targeting. Glycosidic structures present on antibodies, proteins, hormones or other cells can be recognized by membranar lectins [7]. Galactose, N-acetylgalactosamine, mannose, and mannose-6-phosphate receptors have, for example, been identified on hepatocytes and/or cells of the reticuloendothelial system. Many efforts have been devoted lately on grafting saccharidic moieties on the outer surface of liposomes in order to achieve specific recognition [8].

We report here some preliminary data on the biocompatibility of new amphiphiles derived from gluco- and galactopyranose heads fitted with a hydrophobic double tail consisting of one fluorinated chain and one hydrogenated one. Single chain analogs, fluorinated or not, and hydrogenated double-tailed compounds, were investigated for comparison.

The presence of a short polyol segment resulting from the opening of the gluconolactone ring was expected to improve the packing of the hydrophilic head in the outer layer through hydrogen bonding and consequently to increase the stability of the vesicles. An aminoacid (Gly or Lys) or a short peptide (Gly-Gly) spacer can be interposed between the hydrophilic head and the hydrophobic tail with the purpose of controlling the hydrophilic-lipophilic balance (HLB). Some of the hydrogenated tails were fitted with terminal double bonds to allow subsequent polymerization and stabilization of the drug carrying vesicle. Compounds **1-7** were prepared from maltono or lactonolactone [9] (Table I).

TABLE I: Glycolipids investigated, 1-7.

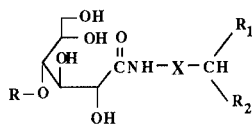

compound	R	R ₁	R ₂	X
1 a	β - D - Gal	H	C ₆ F ₁₃ CH ₂ -	—
1 b	''	H	C ₈ F ₁₇ CH ₂ -	—
1 c	''	H	CH ₂ = CH (CH ₂) ₈ -	—
2 a	''	H	C ₆ F ₁₃ CH ₂ -	CH ₂ C(O)NH (Gly)
2 b	''	H	C ₈ F ₁₇ CH ₂ -	CH ₂ C(O)NH (Gly)
3	''	CH ₂ = CH (CH ₂) ₈ -	CH ₃ (CH ₂) ₁₁ -	—
4 a	''	CH ₂ = CH (CH ₂) ₈ -	CH ₃ (CH ₂) ₁₁ -	CH ₂ C(O)NH (Gly)
4 b	''	CH ₃ (CH ₂) ₁₁ -	CH ₃ (CH ₂) ₁₀ -	CH ₂ C(O)NH "
4 c	''	CH ₃ (CH ₂) ₈ -	C ₆ F ₁₃ (CH ₂) ₂ -	CH ₂ C(O)NH "
4 d	''	CH ₃ (CH ₂) ₈ -	C ₈ F ₁₇ (CH ₂) ₂ -	CH ₂ C(O)NH "
4 e	''	CH ₂ = CH (CH ₂) ₈ -	C ₆ F ₁₃ (CH ₂) ₂ -	CH ₂ C(O)NH "
4 f	''	CH ₂ = CH (CH ₂) ₈ -	C ₈ F ₁₇ (CH ₂) ₂ -	CH ₂ C(O)NH "
5 a	''	CH ₂ = CH (CH ₂) ₈ -	CH ₃ (CH ₂) ₁₁ -	CH ₂ C(O)NH - CH ₂ - C(O)NH - (Gly-Gly)
5 b	''	CH ₃ (CH ₂) ₈ -	C ₆ F ₁₃ (CH ₂) ₂ -	CH ₂ C(O)NH - CH ₂ - C(O)NH - (Gly-Gly)
6	''	CH ₃ (CH ₂) ₁₀ NHC(O) -	C ₈ F ₁₇ (CH ₂) ₂ C(O)NH -	(CH ₂) ₄ (Lys)
7	α - D - Glu	CH ₂ = CH (CH ₂) ₈ -	CH ₃ (CH ₂) ₁₁ -	CH ₂ C(O)NH (Gly)

MATERIALS AND METHODS

Preparation of the dispersions: The single-tailed glycolipids, fluorinated or not, 1a-2b, (Table I), were dispersed by simple shaking in water. The double tailed glycolipids, 3-7, were dispersed either by shaking or by sonication using a Branson B30 sonicator (7 mm probe, 50 % pulsed, power 7, room temperature).

Freeze-Fracture Electron Microscopy: A droplet of sample was deposited on a thin copper holder, quenched in liquid propane and fractured in vacuo (< 10⁻⁶ Torr) with a liquid nitrogen cooled knife (Balzers 30° freeze-etching unit). The replication was performed with Pt-C unidirectional shadowing; the mean thickness

of the metal deposit was of *ca* 1.5 nm. The replicas were washed with methanol and distilled water, and observed on a Philips EM301 electron microscope. The contrast is related to the thickness fluctuations of the metal deposit.

Biological tests : The hemolytic activity of the glycolipids on human red blood cells [10] and their cytotoxicity on Namalva cell cultures [11] were determined as reported in the literature.

In vivo toxicity was assessed by injecting 500 μ l of an isotonic dispersion of the amphiphile to be tested, into the tail vein or intraperitoneally into 10 OF1 male mice of 20-25 g. The growth of the animals, compared to controls, and any signs of toxicity, were recorded over a one month observation period.

RESULTS AND DISCUSSION

All the glycolipids tested were found to form supramolecular structures [12], including the single-chain perfluoroalkylated compound **1b**, which gives helical arrangements, but not the single-chain hydrogenated compound **1c**, which formed only micelles [13]. The nature of the assemblies formed depends dramatically on the nature of the amino acid spacer. Compound **3** was not dispersible. Introduction of a glycine spacer, (compounds **2**, **4** and **7**) improved dispersibility. Compounds **4a-4f** and **7** readily formed stacked lipid bilayers which could be transformed into vesicles by sonication. Compounds **5a-5b** with a glycyglycyl spacer produced clear bluish dispersions by simple handshaking, i.e. without need for sonication. These dispersions consist of single-walled vesicles, as shown by freeze fracture electron microscopy (figure 1). Compound **2b** gives disk-like assemblies rather than vesicles. Vesicles made from glycolipid amphiphile **4a** proved to be stable to heat sterilization (121°C, 15min, 15 psi). These dispersions remained stable for at least 1 month at room temperature as indicated by laser light scattering measurements of particle sizes.

Preliminary biological tests performed on aqueous dispersions of the new glycolipid-derived amphiphiles include cytotoxicity evaluation on Namalva strain cell cultures, *in vitro* interaction with human red blood cells and *in vivo* acute toxicity in mice. Comparative studies underline the favorable contribution of the presence of a fluorinated chain to the biocompatibility of the glycolipid molecules.

Injection of about 0.5 ml of a dispersion of compound **2b** in 0.9% aqueous NaCl was performed *via* the tail vein of 10 mice ; this corresponds to a 625 mg/kg

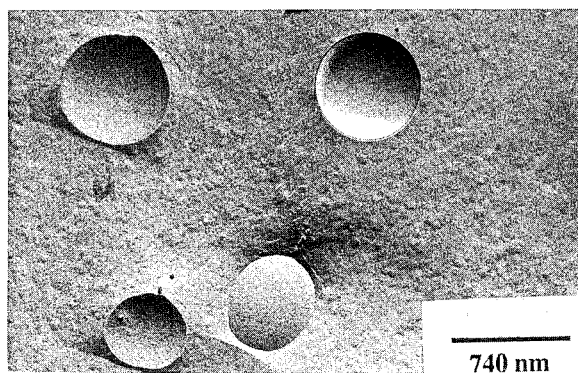

FIGURE 1 : Freeze-fracture electron micrograph of a non-sonicated dispersion of compound **5b** (27300 X).

body weight dose. Intraperitoneal injection in mice (25 ml/kg ; 500mg/kg bw, n = 10) was achieved with isotonic aqueous dispersions of compounds **4a**, **4e**, **4f**. All the animals survived ; their growth and behavior were normal throughout the 30 days following the injection.

An important observation is that the *F*-alkyl chain reduces considerably the hemolytic activity of the amphiphiles. Aqueous solutions of the fluorinated amphiphiles **1a**, **1b**, **2a**, **2b** were innocuous to human red blood cells at a concentration of 50 g/l. On the contrary, compound **1c**, the hydrogenated analog of **1b**, was as hemolytic as distilled water (100% hemolysis) at a ten-fold lower concentration (5g/l). It is also noteworthy that polymerisation of the hydrogenated glycolipid, **1c**, led to polymerized micelles [13] which are no longer hemolytic (0% of hemolysis at 50g/l).

Cell cultures are generally exquisitely sensitive to surfactants and impurities. Cell cultures of the Namalva lymphoblastoid strain were used to assess direct cell toxicity. The isotonic aqueous dispersions of the highly surface active compounds **1b**, **2a**, **2b**, **4a**, **4e**, **4f** at 0.1 g/l did not affect the growth and viability of Namalva cell cultures after incubation for 4 days at 37°C and by comparison to controls.

These preliminary biological tests being encouraging, the potential of these vesicles for drug encapsulation, delivery and targeting is now being investigated.

Acknowledgments : We thank Dr T. Gulik-Krzywicki (Centre de Génétique Moléculaire, CNRS, Gif-sur-Yvette) for his interest and help in the morphological characterisation of some of our dispersions by freeze-fracture electron microscopy, and the Centre National de la Recherche Scientifique and Applications et Transferts de Technologies Avancées for support.

REFERENCES

- [1] J.G. Riess, *Colloids and Surfaces*, xxx (1993).
- [2] T. Kunitake, *Angew. Chem.* **31**, 709 (1992)
- [3] J. G. Riess, C. Santaella, P. Vierling, *Proceed. XXIIe CED Meeting on Surfactants*, Palma de Mallorca, Comité Espagnol Detergencia Tensioactivos y Afines Ed., Barcelone 1991, p. 157.
- [4] M.P. Krafft, F. Giulieri, J.G. Riess, *Angew. Chem.* **105**, 783 (1993)
- [5] C. Santaella, P. Vierling, J.G. Riess, *Angew. Chem. Intl. Ed.*, **30**, 567 (1991)
- [6] J.G. Riess, J. Greiner, S. Abouhilale, A. Milius, *Progr. Colloid polym. Sci.*, **88**, 123 (1992) ; A.A. Pavia, B. Pucci, J.G. Riess, L. Zarif, *Makromol. Chemie* **193**, 2505 (1992) ; J.G. Riess, J. Greiner In "*Carbohydrates as Organic Raw Materials*", VCH Verlagsgesellschaft (ed), Weinheim (in press) ; J. Greiner, J.G. Riess, P. Vierling, In "*Organofluorine Compounds in Medicinal Chemistry and Biomedical Applications*", Filler, Kobayashi and Yagupolski (eds) Elsevier (in press).
- [7] G. Block, S. Harnett, In "*Ciba Foundation Symp.*" John Wiley Chichester UK p. 145 (1989) ; R. U. Lemieux, *J. Chem. Soc. Rev.* **18**, 347 (1989) ; P.D. Stahl, T.E. Wileman, S. Diment, V.L. Shepherd, *Biol. Cell.* **51**, 215 (1984)
- [8] H. Ringsdorf, B. Schlarb, J. Venzmer, *Angew. Chem.* **27**, 113 (1988).; G. Gregoriadis and E. D. Neerunyin, *Biochim. Biophys.. Res. Commun* **65**, 537 (1975) ; J. Haensler, S. Schuber, *Glycoconjugate J.* **8**, 116 (1991)
- [9] B. Pucci, C. Guedj, A. A. Pavia, *Biomed. Chem. Lett.*, 1993 (in press) ; Coulomb, C. Guedj, A.A. Pavia, B. Pucci, J.G. Riess, L. Zarif (in prep.) .
- [10] J.G. Riess, S. Pace, L. Zarif. *Artif. Organs*, **14**, 201 (1990)
- [11] M. LeBlanc, J.G. Riess, D. Poggi, R. Follana, *Pharm. Res.* 195 (1988)
- [12] L. Zarif, T. Gulik-Krzywicki, J.G. Riess, B. Pucci, C. Guedj, A.A. Pavia, *Colloids and Surfaces*, xxx (1993)
- [13] B. Boyer, S. Durand, G. Lamaty, J. M. Moussamou-Missima, A.A. Pavia, B. Pucci, J-P Roque, J. Rouvière, *J. Chem. Soc. Perkin Trans. II*, 1311 (1991)

EFFICACY OF IMAGENT® BP AT 1.5ML/KG IN A RABBIT LIVER TUMOR MODEL

Kristine G. Baker¹, Robert Wrigley², Holly B. Saunders¹, and Robert F. Mattrey¹
MRI Institute (1), University of California, San Diego Medical Center, 410
Dickinson St., San Diego, CA 92103 and Colorado State University (2), 300
West Drake Road, Fort Collins, Colorado 80523.

ABSTRACT

We have shown using a Vx2 rabbit model that 3 and 5ml/kg of perflubron emulsion were highly effective in imaging liver tumors. The results from preliminary clinical trials suggested that should the infusion rate be increased, a 1.5ml/kg may be efficacious. This study determined whether 1.5ml/kg given as a bolus IV would be efficacious to image liver tumors using a Vx2 rabbit model. Vx2 tumors were implanted in 5 NZW rabbits, CT of the liver was performed during held expiration at 80kV and 800mAS, before and shortly after 1.5ml/kg Imagent® BP (ImBP), again at 30 minutes and 3 days. Regions of interest (ROIs) were drawn over the CT image of the spleen, liver, inferior vena cava, and tumor, CT# obtained and average enhancement of each tissue calculated at each time point. 4 animals had tumors .5cm or greater. Precontrast, tumors were faintly seen on CT. Blood was brighter than liver shortly after infusion and isointense with liver at 30 minutes. Tumors did not enhance following contrast. Except for the liver and spleen, all tissues returned to baseline on the 3rd day. Therefore a clinical trial to determine the efficacy of 1.5ml/kg ImBP to image the liver is warranted.

INTRODUCTION

We have shown using a Vx2 rabbit model that 3 and 5ml/kg of perflubron (perfluorooctyl bromide) emulsion were highly effective in imaging liver tumors^[1,2] The major advantage of the radiopaque fluorocarbon emulsion as a CT contrast agent is its long intravascular dwell time. The resultant effect is tissue

Figure 1 Tissue Enhancement with Imagent® BP
Effect of 1.5ml (1.35g) /kg

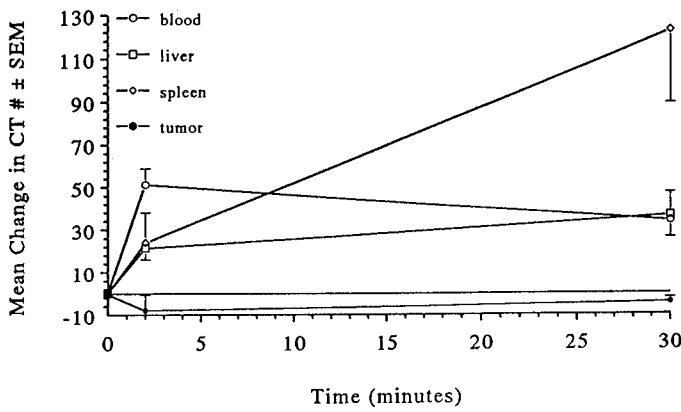
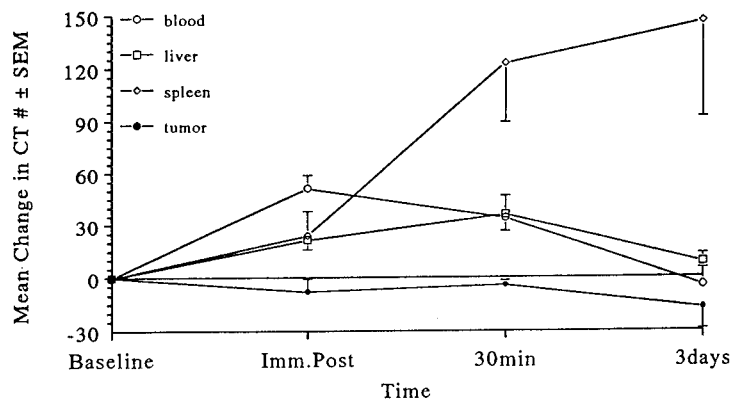

Figure 2 Tissue Enhancement with Imagent® BP
Effect of 1.5ml (1.35g) /kg



FIGURES 1 & 2: Shown here in figures 1 and 2, are the tissue enhancement levels achieved following 1.5ml/kg ImBP. Note that blood was brighter than liver shortly after infusion and became isointense with liver at 30 minutes and returned to baseline at 3 days. Tumors did not enhance at any point after infusion. Liver enhancement was nearly constant over the 30-min imaging window and almost returned to baseline at 3 days. Spleen enhanced similar to liver shortly after infusion but remained markedly enhanced at 3 days.

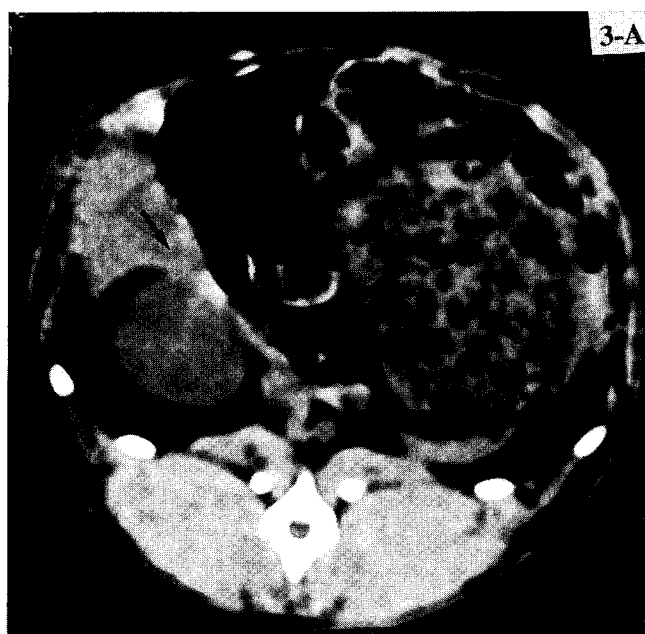

FIGURE 3: Shown Pre (A) and (C) (arrows) and shortly after infusion of 1.5ml/kg ImBP (B) and (D) (arrows), are two separate nodules confirmed on the gross specimen (E). Arrow and curved arrows in E corresponds to nodules seen in A/B and C/D respectively. Note that lesions could not be seen before contrast. They became evident shortly after infusion and at 30 minutes and 3 days (not shown). The size of each nodules is approximately 5mm (A/B) and 7mm (C/D).

(continued)

enhancement that is linearly related to the tissue's blood content.^[3] Because tumors have little blood volume they enhance minimally with blood pool contrast.^[4] Given that there is RE uptake, the liver enhances by selectively accumulating the agent and because of its large blood volume (30% by volume).^[5] The effect is thus to enhance the normal liver to a far greater extent than tumor.^[4] The results from clinical trials suggested that should the infusion rate be increased from 3 to 30ml/min, a 1.5ml/kg may be efficacious.^[4,6-8] A slow infusion rate decreases the persistence in blood diminishing the efficacy of blood pool

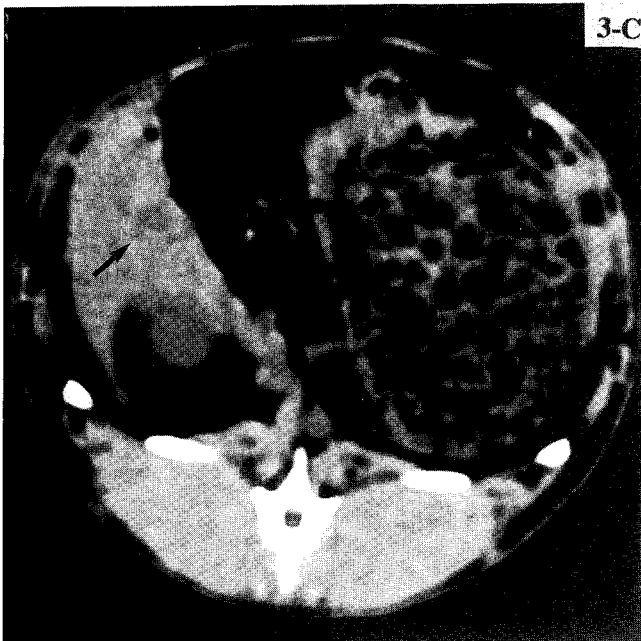
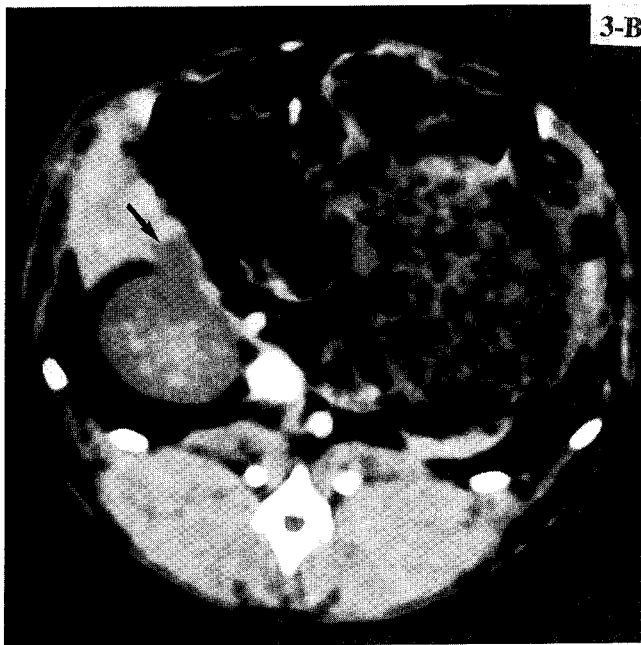

FIGURE 3: Continued

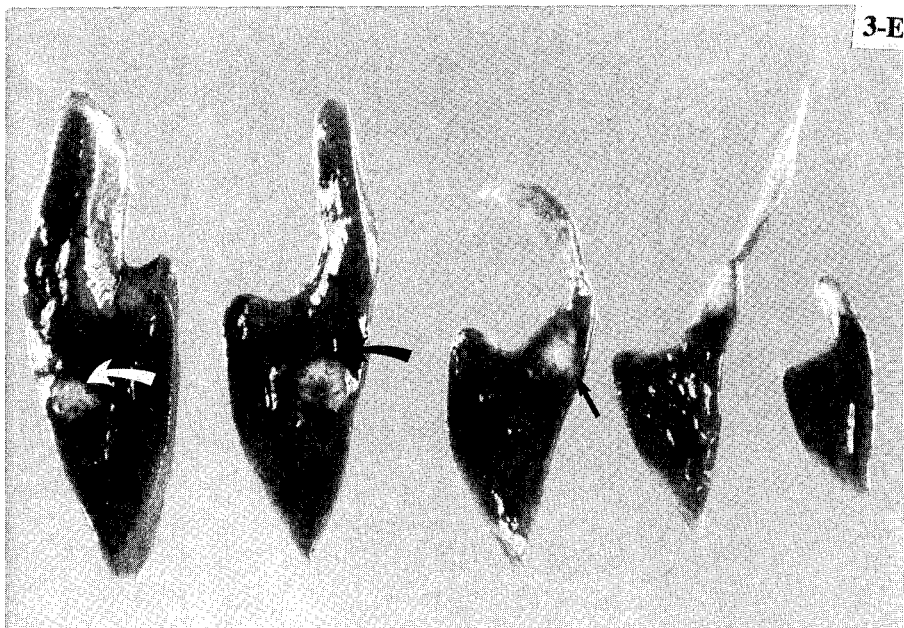
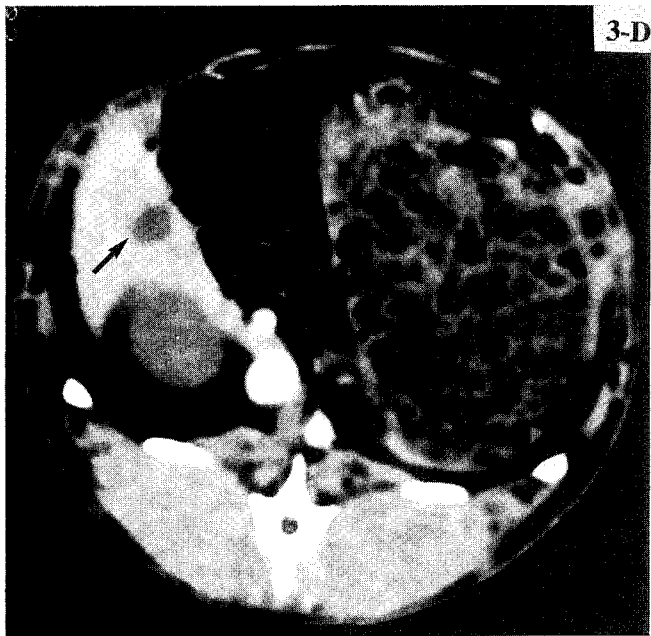

FIGURE 3: Continued

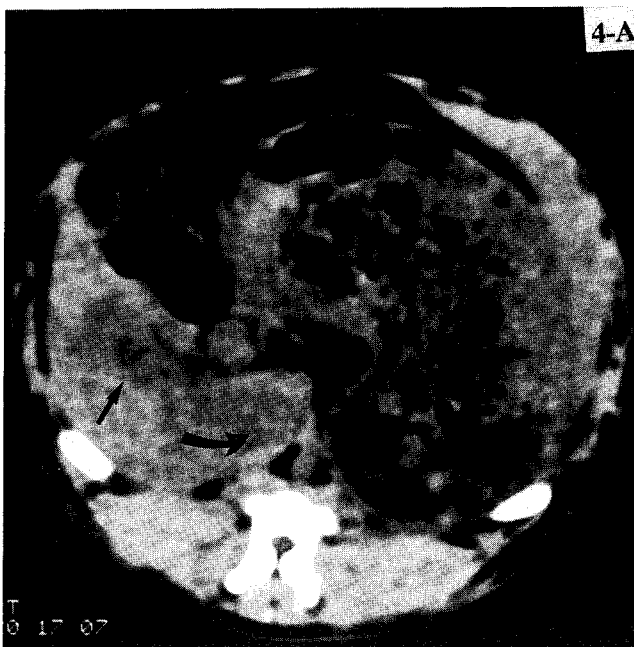

FIGURE 4: Shown Pre (A), shortly after infusion of 1.5ml/kg ImBP (B), and 30 minutes later (C) is a multinodular tumor faintly seen before contrast (arrow) (A). After contrast not only does the tumor become more apparent (arrow) (B) and (C), but its nodular appearance becomes more evident and its margin with liver more clearly defined. Note that blood which was barely darker than liver before contrast (curved arrow) (A), becomes brighter than liver shortly after infusion (curved arrow) (B) and as bright as liver at 30 minutes (curved arrow) (C).

enhancement. Because at slow infusion rate there is rapid RE uptake, and because of the preferential uptake by the spleen of the formulation used in the clinical trial, mild liver enhancement occurred.^[4,6] In this study we aimed to determine whether 1.5ml/kg of Imagent® BP (ImBP) (Alliance Pharmaceutical Corp., San Diego) given as a bolus would be efficacious to image liver tumors in a Vx2 rabbit model.

MATERIALS AND METHODS

Vx2 carcinoma was implanted percutaneously under ultrasound guidance in the inferior lobe of the liver in 5 New Zealand White rabbits. When the tumor

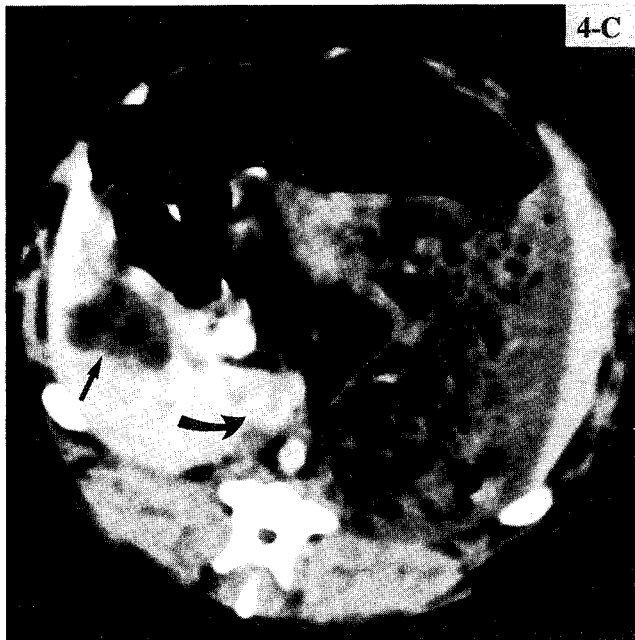
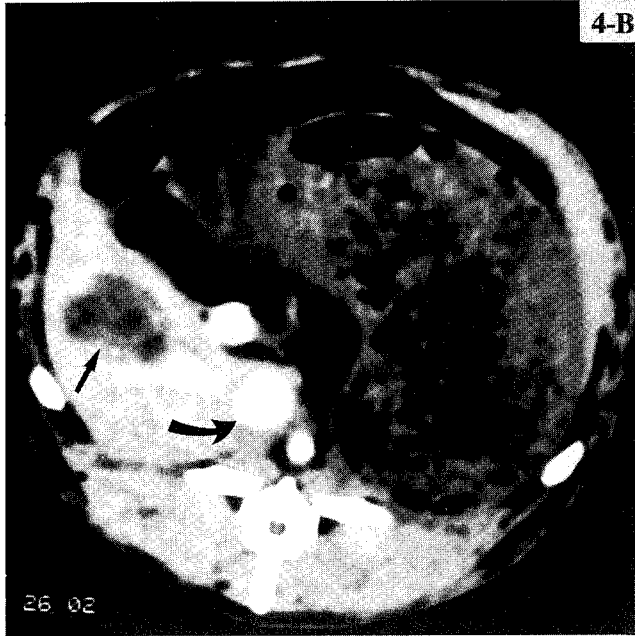

FIGURE 4: Continued

became visible on sonograms, approximately 14 to 21 days after implantation, CT of the liver was performed. Animals were anesthetized and intubated and CT scans obtained during held expiration by hyperventilating between each scan and turning the ventilator off at the end of the expiratory cycle during the 4-sec scanning period. CT of the right inferior lobe of the liver was performed using 80kV, 200mA, 4sec scan time, 13cm FOV, 512x512 matrix, and 1.5mm slice thickness obtained every 5mm. Following the baseline CT, repeat scan of the entire lobe of the liver was performed shortly after the administration of a bolus of 1.5ml/kg Imagent® BP (Alliance Pharm. Corp., San Diego, CA, formulation AF0104 lot ZY12019), and then again at 30 minutes and 3 days. Since ImBP is a 90% w/v emulsion, each animal received 1.35g/kg.

Following the 3-day CT scan, rabbits were sacrificed with an overdose of pentobarbital. The right inferior lobe of the liver was removed, sliced axially and photographed for correlation.

Using the display program of the CT scanner, a region of interest (ROI) was drawn over the spleen, liver, blood pool (inferior vena cava), and liver tumor and average attenuation (CT #) was obtained for each tissue. The average enhancement of each tissue at each time point was calculated by subtracting the baseline value from the value obtained at each time point and the value obtained was grouped for all 5 rabbits. All data is shown as Mean \pm S.E.M.

RESULTS

Of the five animals implanted with VX2, four had tumors 0.5cm or greater at the time of the CT scan. The fifth animal had an anomalous extension of a transverse fissure superior to the kidney which contained fat and appeared as a tumor on the preliminary sonogram. CT scans at baseline showed the tumor faintly in 4 of the 5 animals, but did not accurately depict the size or appearance of tumors. Since the baseline study suggested a tumor in the normal animal, there was therefore 1 false positive and 1 false negative study. Following infusion, all tumors became apparent, their size and appearance clearly depicted. The linear appearance of the defect in the rabbit with an anomalous fissure became clear and allowed its recognition as such in prospect. Thus CT following 1.5ml/kg perflubron emulsion infusion, had no false positives or false negatives.

CONCLUSION

CT following the administration of 1.5 ml (1.35g) /kg of Imagent® BP enhanced blood and liver significantly to allow the detection of liver tumors in rabbits. Although no rim enhancement was observed as was seen at higher dosages,[1,2] tumors were easily detected within the 30-minute imaging window. Given this efficacy in animals, clinical trial at this dosage is warranted.

REFERENCES

1. RF Mattrey, DM Long, F Multer, et al. Perfluorooctylbromide: A Reticuloendothelial Specific and a Tumor Imaging Agent for Computed Tomography. *Radiology*, 145:755-758 (1982).
2. RF Mattrey: Perfluorooctylbromide: A new contrast agent for CT, sonography and MR imaging: *AJR*, 152:247-252 (1989).
3. BJ Hillman, ML Stanley, P Tracey, W Swindell, DM Long. CT Determination of Renal and Hepatic Microvascular Volumes in Experimental Acute Renal Failure. *Invest Radiol*, 17:41-45 (1982).
4. M Behan, D O'Connell, RF Mattrey, DN Carney. Perfluorooctyl bromide as a contrast agent for CT and Sonography: Preliminary clinical results, *AJR*, 160:399-405 (1993).
5. PB Dean, L Kivisaari, M Kormano. Contrast enhancement pharmacokinetics of six ionic and nonionic contrast media. *Invest Radiol*, 18:368-374 (1983).
6. JN Bruneton, MN Falewee, C Balu-Maestro, F Normand, RF Mattrey: Perfluorooctylbromide and Hepatosplenic Computed Tomography. Preliminary Clinical Study. *Investigative Radiology*, 23(Suppl 1):S306-S307 (1989).
7. RF Mattrey. Potential role of PFOB in liver lesion detection and characterization with CT. *Radiology*, 170:18-20 (1989).
8. JG Riess, JL Dalfore, GK Hanna, DW Klein, MP Crafft, TJ Poura, EG Schutt. Development of Highly Fluid, Concentrated and Stable Fluorocarbon Emulsions for Diagnosis and Therapy. *Biomat., Art. Cells and Immob. Biotech*, 20:839-842 (1992).

THE USE OF IMAGENT®BP AS A BLOOD POOL
CONTRAST AGENT TO VISUALIZE AND QUANTITATE
LIVER TUMOR BURDEN

G.C. Steinbach, K.G. Baker, G.L. Lim, R.F. Mattrey, and R.S. Arellano
Department of Radiology
University of California, San Diego
San Diego, California

ABSTRACT

The accurate quantitation of liver tumor burden and visualization of lesions in three dimensions (3D) can assist in treatment planning and can allow monitoring of therapy. Previous attempts have used CT and standard contrast media. Because the iodinated agents rapidly diffuse into tumors, usually effacing, and at time enhancing tumor edges, they decrease accuracy and make image segmentation difficult. CT portography suffers from flow related artifacts and does not allow the distinction of tumors from hemangiomas. Blood pool contrast is ideal in this setting since it enhances liver, liver vessels and hemangiomas, but not tumors, 'physiologically' splitting the image into normal and abnormal tissues. This ongoing study assesses the feasibility of this technique to visualize tumor and presents a scheme to automatically quantitate tumor volume. It utilized a rabbit VX2 liver tumor model and CT scanning shortly after the infusion of 3 ml/kg perflubron emulsion. Cut sections of the frozen carcass served as gross pathologic correlation. Images were imported onto a Sparc workstation, 3D reformatted and tumor and liver volume calculated. Histograms of pixel intensity clearly separated tumors from liver and liver from surrounding structures allowing the easy demarcation of tumor and liver margins.

INTRODUCTION

The high prevalence of colorectal neoplasia, accounting for the second highest cause of death from cancer, and their predilection to metastasize to liver,[1] has made the liver one of the more important organs to examine in these patients. The presence of metastases significantly lowers the prognosis for survival and has stimulated aggressive measures for therapy, such as indwelling arterial catheters to deliver chemotherapy, surgical resection, and percutaneous tumor ablation.[1] The major deficiencies of these techniques have been the inability to adequately localize, count, and measure metastatic foci. The demands placed on available imaging techniques are heightened because the liver is hidden by the ribs, moves with respiration and cardiac pulsation, making imaging difficult. The use of computed tomography (CT) to estimate liver tumor volume has been proposed by several investigators because of its importance in guiding surgical management decisions and monitoring response to therapy.[2,3] Although CT is the most practical, there is difficulty using this technique because of its inability to achieve optimal image segmentation to recognize tumor from non-tumorous tissue.[3] This problem exists because liver tumors require the use of contrast media and the available agents have a significant false negative and positive rates, which are a result of complex enhancement patterns and indistinct tumor margins.[2] Rather than using complex image segmentation schemes to reduce these shortcomings, we attempted to solve these problems by using a liver specific contrast agent that also enhances the vascular space. Based on our experience with this agent (perflubron (perfluoro octyl bromide) emulsion, Imagent® BP) [4], we believe that it is ideal because it enhances the liver homogeneously as well as hepatic vessels and hemangiomas without enhancing tumors.[5] These properties provide fewer false positives and negatives and sharper tumor margins, essentially creating 'physiologic' image segmentation (Figure 1).

MATERIALS AND METHODS

VX2 tumor cells were harvested from a NZW rabbit carrier animal and suspended in a minimal essential medium with approximately 5×10^6 cells/ml. One or more tumor sites were produced in the experimental animals by the direct injection of 0.2 ml of the suspension in one or more locations in the liver under ultrasound guidance. When lesions reached ~1 cm in size, CT scans using a

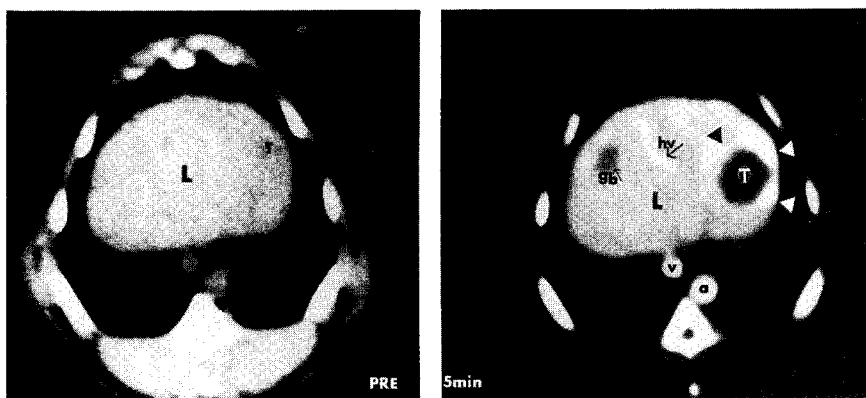

FIGURE 1 CT image of the liver with implanted VX2 tumors taken pre and 5 min post Imagent® BP administration. Note that while the tumor center (T) was nearly isodense with liver (L) pre-contrast, it became markedly hypodense at 5 min because of the biodistribution of Imagent® BP (the tumor is hypovascular compared to the liver).

GE9800 scanner (General Electric, Milwaukee, WI) were obtained before and immediately after the infusion of 3 ml/kg Imagent® BP (ImBP) (Alliance Pharm. Corp., San Diego, CA). The images were acquired with a 16 cm field of view and 512 x 512 image matrix over the entire liver region using 1.5 mm scan thickness taken every 1 mm. After imaging, the animals were sacrificed and frozen at -70°C for subsequent pathologic correlation.

The acquired images were retrieved on a CEMAX C-500 Workstation (Fremont, CA). This system is based on a Sparc Workstation running CEMAX VIP 1.01 software and equipped with a radiology tape reader. The post contrast datasets were processed by using thresholding techniques to isolate the liver from the surrounding abdominal structures. The liver margins were detected by selecting the range of CT#s encountered within the liver (80 to 170 Hounsfield Units) and performing an edge detection scheme. Once the liver margins were identified, non-liver tissue was eliminated from each image, reducing computational demands. Identification of the tumor tissue within the liver was similarly accomplished by placing the cursor within the tumor and thresholding the

tumor tissue by taking advantage of the improved contrast (~40HU) and demarcation created by the addition of ImBP. Once the liver and tumor tissues were identified, the images were reconstructed in 3D and displayed.

Slices were obtained from the frozen carcasses which were sectioned into 2 mm slices using a bandsaw with a 1 mm blade for anatomical correlation.

RESULTS AND DISCUSSION

The applicability and accuracy of computer processing techniques are substantially increased with the presence of improved contrast between the tissues of interest.[6] The addition of ImBP significantly improved the contrast observed between the liver and tumor. This contrast improvement can be illustrated in a histogram obtained over a selected region of interest (Figure II). The histogram has dual peaks, the left peak corresponds to the tumor which has a lower CT#, and the right peak shows the liver at the higher CT#. ImBP accumulates in the liver, which shifts the liver histogram peak to the right, increasing liver-tumor contrast. The improvement in contrast provided a means of 'physiological' image segmentation, which allowed greater application of computer image processing techniques.[3]

In addition to the improved contrast, it is important for the contrast agent to improve the demarcation of the tissue boundaries.[7] In CT imaging, partial volume effects are the primary cause for fuzzy margins around tissues. Patient motion, scan thickness, matrix size, and contrast agent tissue selectivity all impact the degree of partial voluming observed in an image. The lack of uptake of ImBP by the tumor shortly after infusion provides a mechanism which selectively improves the demarcation of normal versus diseased tissue. This concept can be illustrated by analyzing the profile of a scan line which crosses liver and tumor tissue (Figure III). The liver pixels are the 'plateau' and the tumor tissues are the 'valley' in the scan line profile. The demarcation between the tissues is illustrated by the slope of the drop-off between the liver and tumor regions. To improve the tissue demarcations, contrast agent selectivity or scanning parameters must be improved to reduce partial voluming effects.

The 'physiological' image segmentation provided by perflubron emulsion allows for greater efficiency and accuracy in image quantitation applications.[3,6]

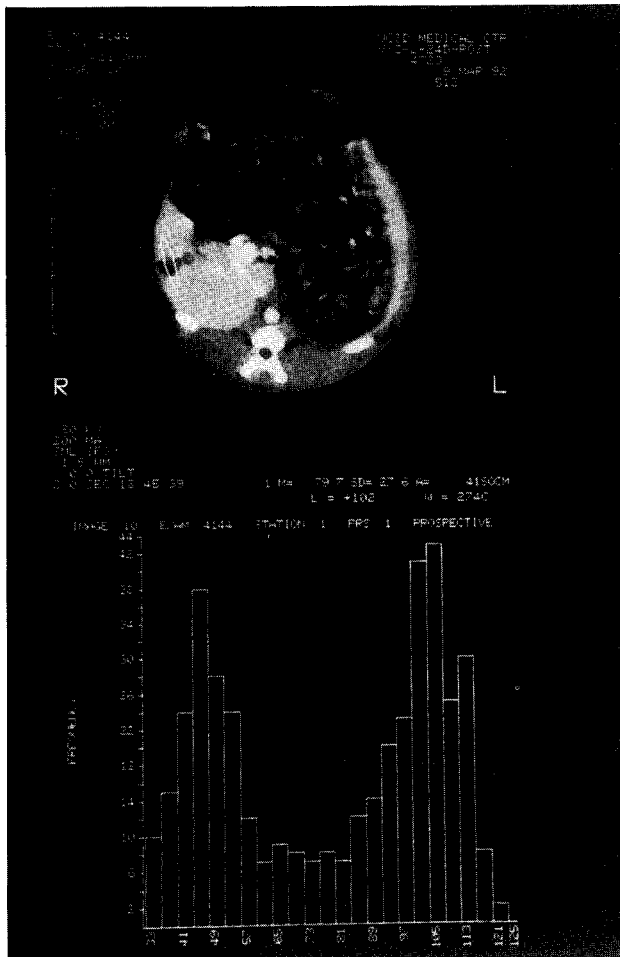

FIGURE II Histogram obtained from ROI analysis from a liver-tumor containing region. The tumor pixels are the left group above and the liver pixels are the right group. The degree of contrast between the two tissues is illustrated by the horizontal distance between the peaks.

CT Number vs Position Two adjacent scan lines

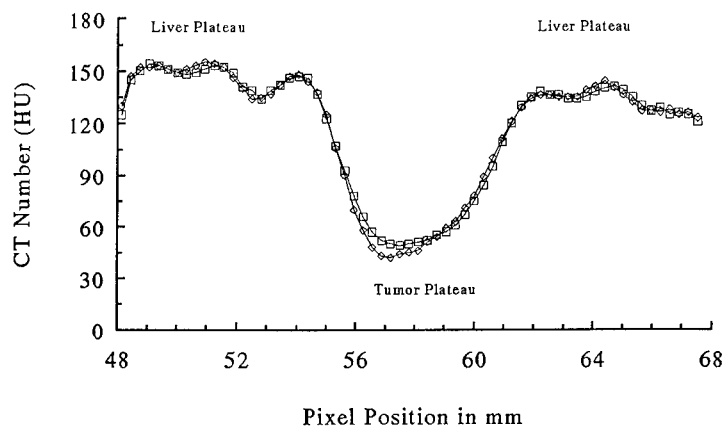

FIGURE III Line profile taken from scan lines within a ROI which incorporates both liver and tumor tissue. The demarcation between the tissues is illustrated by the slope of the line between the liver (plateau) and tumor (valley) pixels (3.2pixels/mm). Tumor volumes can be calculated by multiplying the number of pixels within the threshold range by the corresponding geometric conversion factor.

In post-contrast image sets, liver and tumor volumes were determined by using edge detection schemes which outlined the tissues of interest based upon the CT numbers. Once the tissues were isolated on each slice, liver and tumor volumes can be determined based upon the number of pixels contained within the tissue and the volume conversion factor which is based upon the scan thickness and image matrix. The liver-tumor burden can then be calculated based upon the ratio of tumor to liver volume. This process can be easily automated to yield consistent and reliable measurements in images obtained after the administration of ImBP.

Anatomical slices were compared to the CT images to verify the presence of tumor within the liver tissue. The geometric orientation was not identical between the slices and images, but obvious correlation was evident. Planimetry, accomplished by digitizing and analyzing photographs of the slices, was performed as a technique to validate volume measurements. However, correction factors



FIGURE IV 3D reconstruction of the liver (light) and implanted Vx2 tumor (dark). The addition of ImBP significantly enhanced the contrast between tumor and liver, thereby improving tissue classification. The brightness at the liver edges and around the gallbladder within the liver is a result of thresholding artifacts which are unable to eliminate these inhomogeneities.

must be employed to compensate for tissue loss as a result of the gross sectioning procedure. Validation may also be accomplished by imaging known targets with contrast differences similar to that observed between the liver and tumor tissue. Preliminary phantom studies with known tumor targets showed that computerized measurements performed as described, corresponded within 5% of true target volumes .

After the liver and tumor tissues were isolated, reconstruction was performed in 3D to aid in the visualization of the anatomy (Figure IV). Tissue differentiation based on CT numbers were used to classify the tissue as liver or tumor. Colors were then assigned to the classified tissues and 3D reconstruction was performed for visual display of the tumor. 3D reconstruction provides the viewer with a vivid representation of tumor size and shape as compared to surrounding liver. These reconstructions are easier to interpret than those observed in the planar CT images. The improved visualization may prove useful in various aspects of tumor treatment planning.

Detection and quantitation of liver tumors is difficult with standard CT imaging because of the lack of sufficient contrast between the normal and diseased tissues. The use of contrast agents reduces these difficulties, but many of the currently available agents suffer due to significant false negative and positive rates and indistinct tissue margins due to a lack of sufficient selectivity. Blood pool contrast agents such as Imagent[®] BP provide an improved means for hepatic lesion detection and provide 'physiological' image segmentation. This greatly improves visual diagnostic potential and increases the utility of computer image processing techniques, including automation. The use of blood pool contrast agents and the resulting improved image quantitation techniques may assist the radiologist, surgeon, and oncologist in patient management with respect to the detection, visualization, and monitoring of liver tumors and responses to tumor therapy.

ACKNOWLEDGEMENTS

This work supported in part by a grant from Alliance Pharmaceutical Corporation, San Diego, California.

REFERENCES

1. AE Chang, et al: Determinants of Survival in Patients with Unresectable Colorectal Liver Metastases. *J. Surg. Onc.*; 40:245-251, (1989).

2. DL Miller, et al: Hepatic metastasis detection: comparison of three CT contrast enhancement methods. *Radiology*; 165:785-790, (1987).
3. GR McNeal, et al: Liver Volume Measurements and Three-dimensional Display. *Radiology*; 169(3):851-854, (1988).
4. JG Riess, et al: Development of Highly Fluid, Concentrated and Stable Fluorocarbon Emulsions for Diagnosis and Therapy. *Biomat., Art. Cells and Immob. Biotech.*; 20:839-842, (1992).
5. RF Mattrey, et al: Use of Perfluorooctyl bromide (PFOB) to Detect Liver Abscesses with CT: Safety and Efficacy. *Invest. Radiol.*; 26:792-798 (1991).
6. T Kashiwagi, et al: 3D demonstration of liver and spleen by a computer graphics technique. *Acta Radiologica*; 29:27-31 (1988).
7. GR McNeal, et al: Liver Volume Measurements and Three-dimensional Display. *Radiology*; 169(3):851-854 (1988).

**CHARACTERIZATION AND MECHANISM OF SIDE-EFFECTS OF
OXYGENT™ HT (HIGHLY CONCENTRATED FLUOROCARBON
EMULSION) IN SWINE**

S.F. Flaim, D.R. Hazard, J. Hogan[†], and R.M. Peters[†]
Alliance Pharmaceutical Corp., San Diego, CA 92121 and

[†]Department of Surgery, University of California at San Diego, San Diego, CA
92093

ABSTRACT

Perfluorooctyl bromide is an oxygen-carrying perfluorocarbon presently under development as an artificial blood substitute (*Oxygent™ HT*). Intravenous (i.v.) *Oxygent HT* elicits a mild side-effect profile in man characterized by early onset headache and nausea and delayed onset fever. Early onset flushing has also been observed. Species of *Artiodactyla* are sensitive to particulate injections and demonstrate a transient pulmonary hypertensive response thought to be associated with the large number of pulmonary intravascular macrophages found in these species. Because of this sensitivity, we chose the swine as a model for further investigations. In anesthetized and conscious swine, i.v. *Oxygent HT* transiently increased mean pulmonary artery pressure (mPAP) and caused flushing. Both effects peaked at 30 min post injection and were resolved by 2 hrs. Plasma thromboxane B₂ (TxB) increased in response to *Oxygent HT*. *Oxygent HT*-induced changes in mPAP, flush, and plasma TxB were blocked by aspirin and ibuprofen. Dexamethasone and SQ 29,548 (thromboxane receptor antagonist) blocked the mPAP increase. In conscious swine, *Oxygent HT* caused a febrile response which was blocked by ibuprofen or dexamethasone. Thus, both early- and late-onset effects of *Oxygent HT* in swine are blocked by interference with the arachidonic acid cascade. These findings suggest that the 2-phase "flu-like" syndrome induced by *Oxygent HT* is secondary to the release of products of the arachidonic acid cascade and may be effectively prophylaxed in man with corticosteroids or long plasma half-life cyclooxygenase inhibitors.

INTRODUCTION

Perfluorooctyl bromide (perflubron) is an oxygen-carrying perfluorocarbon (PFC) under development as a temporary blood substitute (*Oxygent™ HT*) [1]. *Oxygent HT*, a phospholipid emulsion (90% perflubron w/v) with a mass median particle size of approximately 0.2 μ m, elicits both acute and delayed clinical side effects when administered i.v. to human volunteers. The acute effects include skin flushing (similar to the "niacin flush" thought to occur as a result of prostaglandin D₂ release) and backache, and occur between 0 and 2 hours post-injection. The delayed effects are characterized by a "flu-like syndrome" (including fever and nausea) which occurs between 2 and 24 hours post-injection. Species of the Order *Artiodactyla* (which includes domestic swine) demonstrate early, transient pulmonary hypertensive and skin flushing responses, and a delayed febrile response to particulate injections (including injections of perflubron emulsion) [2]. Because of this enhanced sensitivity to particulate injections, domestic swine (anesthetized and conscious) were chosen as the model for further investigations of i.v. *Oxygent HT* clinical side effects.

RESULTS

In anesthetized and conscious swine, *Oxygent HT* (3 mL/kg administered i.v. at an infusion rate of 0.2 mL/kg/min) elicited an early, transient rise in mean pulmonary artery pressure (mPAP) and skin flushing (Figure 1, Panel A), both of which peaked at 30 minutes post injection and resolved completely by 2 hours. No concurrent change in arterial pressure, cardiac output, or heart rate was observed. Under these same conditions, changes were observed in plasma thromboxane B₂ (TxB) levels (0-2 hrs post-injection) with no change in plasma bradykinin, histamine or serotonin levels. The rise in mPAP and skin flushing were successfully blocked by prophylaxis with aspirin (20 mg/kg, p.o.), which also blocked the transient rise in plasma TxB levels. Ibuprofen (20 mg/kg, p.o.), indomethacin (1 mg/kg + 1 mg/kg/hr, i.v.), dexamethasone (1 mL/kg x2, i.v.), and the TxB receptor antagonist, SQ 29,548 (0.2 mg/kg + 0.2 mg/kg/hr, i.v.) also blocked the rise in mPAP, while SKF 104,353 (a leukotriene D₄ receptor antagonist, 3 mg/kg + 3 mg/kg/hr, i.v.), WEB 2086, (a platelet activating factor antagonist, 0.1 mg/kg + 0.1 mg/kg/hr, i.v.) and benadryl (a histamine antagonist, 1 mg/kg i.v.) had no effect on this response.

In conscious swine, i.v. *Oxygent HT* also elicited a delayed febrile response. This response was characterized by a 1 to 2° C increase in body temperature which peaked at 4 hrs post injection and resolved to varying degrees over the next 2 to 24 hours (Figure 1,

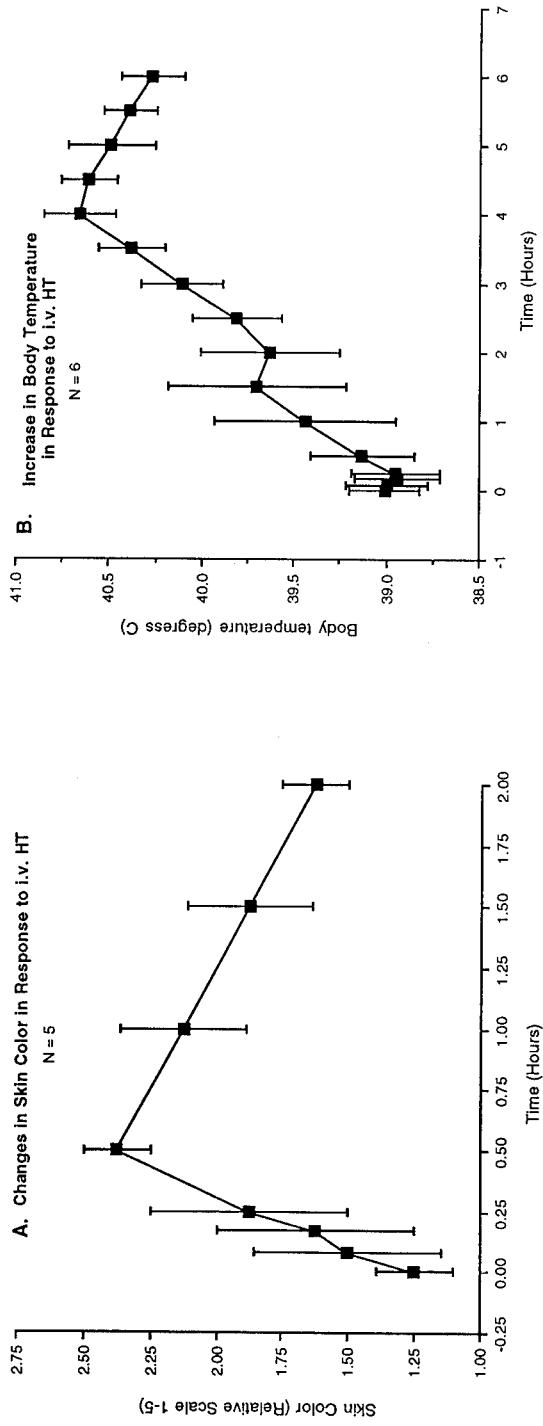

FIGURE 1. Change in skin color (Panel A) and body temperature (Panel B) in response to i.v. *Oxygent HT*. Data are Means \pm SEM.

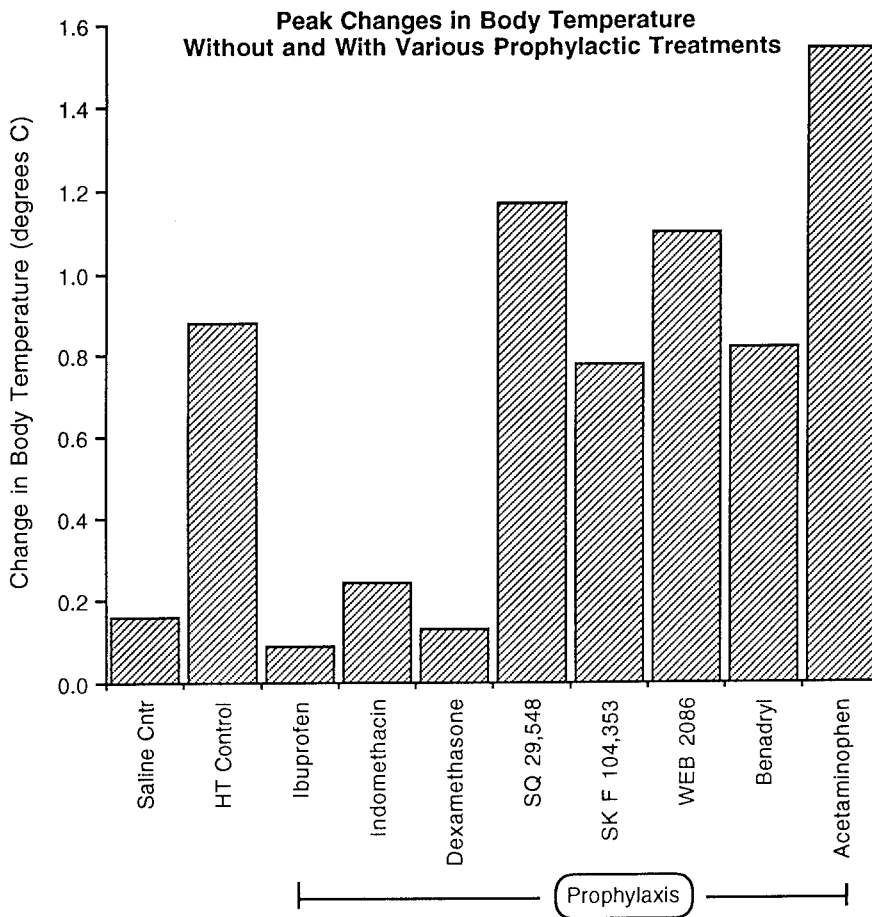

FIGURE 2. Peak changes in body temperature after *Oxygent HT* injection with and without various prophylactic treatments.

Panel B). This delayed febrile response was successfully blocked by ibuprofen, indomethacin, and dexamethasone. Benadryl, SQ 29,548, WEB 2086, acetaminophen (10 mg/kg, p.o.), and SKF 104,353 had no effect on the febrile response (Figure 2).

DISCUSSION

Intravenous *Oxygent HT* elicits both acute (rise in mPAP and skin flushing) and delayed (fever) responses in swine. The early, transient rise in mPAP (due to the activation

of pulmonary intravascular macrophages) and skin flushing (caused by the substantial release of prostaglandins upon macrophage activation) are blocked by long plasma half-life cyclooxygenase inhibitors (ibuprofen and indomethacin) and corticosteroids (dexamethasone). Similarly, the delayed febrile response is eliminated by prophylaxis with a cyclooxygenase inhibitor or corticosteroid. These interfere with the arachidonic acid cascade, suggesting that the responses elicited by i.v. *Oxygent HT* are secondary to products of the arachidonic acid cascade released from phagocytic cells (macrophages) normally involved in the clearance of particulates from the circulation. The results from these studies indicate that the clinical side effects of i.v. *Oxygent HT* in man may be effectively prophylaxed with corticosteroids such as dexamethasone, or long plasma half-life cyclooxygenase inhibitors such as ibuprofen or indomethacin.

ACKNOWLEDGMENTS

The authors thank Mr. Matteo Levisetti and Mr. James Bell for their technical assistance in the laboratory, and Ms. Dorothy Saewert for preparation of the manuscript.

REFERENCES

1. C. Arlen, R. Follana, M. Le Blanc, C. Long, D. Long, J.G. Riess, and A. Valla. Formulation of Highly Concentrated Fluorocarbon Emulsions and Assessment by Near-total Exchange Perfusion of the Conscious Rat. Blood Substitutes. T.S. Chang and R.P. Geyer (eds), Marcel Dekker, Inc., New York, p. 455 (1989).
2. A.E. Warner, B.E. Barry, and J.D. Brian. Pulmonary Intravascular Macrophages in Sheep: Morphology and Function of a Novel Constituent of the Mononuclear Phagocyte System. *Lab Invest* 55:276 (1986).

ART. CELLS, BLOOD SUBS., AND IMMOB. BIOTECH., 22(4), 1517-1518 (1994)

FORTHCOMING MEETINGS

X WORLD CONGRESS OF THE INTERNATIONAL SOCIETY FOR ARTIFICIAL ORGANS (ISAO)

Nov.15-18,1995,

Taipei International Convention Center,Taipei, Taiwan.

Congress President: Professor Chun-Jean Lee, National Taiwan University,

Further information can be obtained from:

Congress Secretariat:

c/o Prof. Chun-Jean Lee,

Department of Surgery, National Taiwan University, Medical Centre,

7, Chung-Shan S. Road, Taipei, Taiwan.

FAX 886-2-3511434

TEL 886-2-3511434

HIGHLIGHTS IN BIOENGINEERING

Sponsored by the "International Society for Artificial Organs" and the
Austrian Society for Artificial Organs and Biomaterials"

14-15 Oct., 1994

Krems, Austria

Further information can be obtained from:

Mrs. Anita Aichinger

Interdisciplinary Institute of Bioengineering

1518

FORTHCOMING MEETINGS

Wissenschaftliche Landesakademie
(Danube University)
Dr. Karl Dorrekk Str. 30
1-3500 Krems
Tel: +43-2732-70545-150/166
Fax: +43-2732--70545-160/165

AUTHOR INDEX TO VOLUME 22

A

- Aarden, L. A., 835
Acharya, A. S., 695, 747
Afonin, N. I., 1281, 1295, 1337
Agishi, T., 789
Agterberg, J., 577
Akama, K., 559, 901
Alayash, A. I., 373
Alexander, J. B., 955
Amano, M., 559, 939
Amyot, K., 1463
Anderson, P. J., 753
Anderson, S., 695
Andracki, M., 27
Antich, P. P., 1361
Aprosin, U. D., 1281, 1331
Archer-Paik, L. E., 457
Arellano, R. S., 1501
Arien, A., 71
Arlauskas, R. A., 1175, 1317
Atabek, U., 955
Augustin, A. J., 1223, 1231
Awad, M., 613
Azari, M., 701
Barber, P., 1205
Barnes, B., 633
Barnikol, W. K. R., 725
Bartlett, R. H., 1389
Baudin, V., 733, 739
Beissinger, R., 487
Biessels, P. T. M., 577, 835
Biffi, E., 245
Bihoreau, M.-T., 739
Bilello, K., 819
Biro, G. P., 753, 1343
Bleeker, W. K., 577, 835
Botzlar, A., 587
Bowersox, J. C., 145
Bradley, J. D., 1161, 1199
Bradley, K., 1
Bradley, R., 657
Brasile, L., 327, 1463, 1469
Brawner, W. R., 1155
Brewer, W. G., Jr., 1155
Brockner Ryan, B. A., 373
Bruneton, J. N., 1421
Burak, B., 1377
Burhop, K., 91
Bush, S., 917
Buxton, R. B., 1449

B

- Baker, K. G., 1491, 1501
Bakker, J. C., 577, 835
Balla, G., 207
Balla, J., 207

C

- Camishion, R. C., 955
Casciani, C. U., 109
Cashon, R. E., 373

Casteel, D. A., 27
 Cavin, J. C., 1175, 1199
 Cedrati, N., 867
 Cernaianu, A. C., 955, 965
 Cerny, E. R., 633
 Cerny, L. C., 633
 Chait, B. T., 695
 Chang, T. M. S., 159, 171, 687, 883,
 889
 Chao, T. L., 695
 Cianciulli, P., 109
 Cilley, J. H., Jr., 965
 Cippolini, S., 1421
 Clarke, J., 327, 1463, 1469
 Coalson, J. J., 1381
 Cole, D. J., 1, 813
 Cole, F., 91, 819
 Colotti, M. T., 245
 Coppes, V., 361
 Cornélus, C., 1183, 1267
 Costabile, J., 955
 Cox, C., 1397
 Crowell, R. M., 83
 Csapó, C., 587
 Czuba, B., 657

D

David, S., 769
 de Groot, E. M., 835
 del Balzo, U., 1199
 deLemos, R. A., 1381
 Dellacherie, E., 669
 DelRossi, A. J., 965
 DelVecchio, P., 1463, 1469
 den Boer, P. J., 577, 835
 Doronina, N. N., 1295
 Drummond, J. C., 1, 813
 Dubernard, J. M., 1455
 Dumoulin, A., 733
 Dupuis, N. P., 827, 1369
 Dupuy, B., 71

E

Eaton, J. W., 207
 Edelstein, S. J., 733
 Eilenberg, S. S., 1477
 Eschwege, F., 1355
 Evans, G. L., 457

F

Faithfull, N. S., 181, 965, 1161
 Faivre, B., 543, 551
 Feola, M., 525, 777
 Ferreira, A., 633
 Fields, T. K., 1175, 1199, 1205, 1381
 Flaim, K., 1429
 Flaim, S. F., 1043, 1169, 1199, 1205,
 1381, 1511
 Follana, R., 1193
 Fowler, S. A., 27
 Fox, W. W., 1397
 Frantantoni, J. C., 373
 Frezard, F., 1403
 Friesenecker, B., 841
 Fuhrman, B. P., 1133, 1377

G

Gallucci, J. G., 965
 Gaprindashvili, T., 965
 Gelman, A., 479
 Gerber, M. J., 457
 Gilbert, C., 535, 795, 805
 Goins, B., 9, 909
 Gomez, C. S., 361
 Gorry, F., 1455
 Goto, H., 875
 Grandgeorge, M., 543, 551, 669
 Greenburg, A. G., 613, 619
 Greenspan, J. S., 315
 Greiner, J., 1273, 1421

Guclu, C., 1449
Guedj, C., 1485
Guerra, J. M., 1381
Guichard, M., 1355
Guillod, F., 1273
Gulati, A., 593, 603
Guo, Q., 1449

H

Habif, S. S., 1325
Hai, T. T., 923
Haisch, C., 327, 1463, 1469
Hale, S., 1069
Hamilton, I. N., Jr., 91
Hanna, G., 1429, 1441
Hayasaka, Y., 789
Hazard, D. Y., 1161, 1199, 1511
Hecht, R., 587
Henderson, R. A., 1155
Henry, C. J., 1155
Hernan, L. J., 1133, 1377
Hess, J. R., 145, 361, 625
Hirschl, R. B., 1389
Hodson, W. A., 1121
Hogan, J., 1161, 1511
Holden, S. A., 827
Holm, B. A., 1133
Holman, W. L., 979
Holthuis, J. C. M., 577
Honkan, V. A., 27
Hopkins, R. M., 1381
Horodniak, J., 1205
Houmes, R., 1205
Huang, H., 719
Hurst, G., 27

I

Ikomi, F., 1441
Ilan, E., 677, 687, 769

Inghilleri, G., 245
Intaglietta, M., 137, 841

J

Jackson, J. C., 1121, 1381
Jacob, H. S., 207
Jaffin, J., 819
Jennings, R. B., 253
Johnson, M., 535, 795, 805
Jones, R. T., 415

K

Kaca, W., 387
Kakizaki, T., 895, 933
Kamitani, T., 503
Kan, P., 641
Katsuyama, S. S., 1
Kawakami, Y., 559
Kechner, N., 1409
Keipert, P. E., 965, 1161, 1169, 1199,
1205
Keller, H., 695
Kennedy, J. F., 115
Kiger, L., 733
Kim, H. W., 613, 619
Kim, S. A., 625
Kinner, R. A., 1205, 1307
Kister, J., 739
Kitabatake, A., 939
Klein, D. H., 1169, 1199, 1317
Klein, H. G., 123
Klipper, R., 909
Kloner, R. A., 1069
Kluger, R., 415
Kobayashi, K., 895, 901, 933
Koester, M., 1231
Komatsu, T., 855, 895, 933
Kopperman, M., 1429

Kornbrust, L., 1205, 1215
 Kornbrust, E. S., 1215
 Kossovsky, N., 479
 Krafft, M. P., 1183, 1267, 1455
 Kumar, R., 695
 Kurmacheva, O. A., 1295
 Kusomoto, T., 827, 1369

L

Labrude, P., 543, 551, 867
 Lachmann, B., 1205
 Lambin, P., 1355
 Lane, T. A., 1215
 Lartigau, E., 1355
 Lasker, S. E., 1055
 Lattes, A., 1007
 Leach, C. L., 1133, 1377
 Leakakos, T., 1199, 1205
 Lee, C. J., 641
 Leese, P., 1429
 Lejbkovic, F., 769
 Léonard, M., 669
 Le Ridant, A. M., 1355
 Le Tellier, Y. C., 443
 Levisetti, M. S., 1161
 Ligler, F. S., 9
 Lim, G. L., 1501
 Linberg, R., 535, 795, 805
 Lister, C. W., 171
 Liu, F., 827, 1369
 Liu, H., 789
 Liu, J., 1175, 1299
 Liu, M., 827, 1369
 Lox, C. D., 525, 777
 Luboinski, B., 1355
 Lusinchi, A., 1355
 Lutz, J., 1223, 1231

M

Ma, X., 43

McCoy, S., 955
 Macdonald, V. W., 361, 565
 McGiffin, D. C., 979
 McGoron, A. J., 1243, 1251
 McGunegle, D. E., 525
 Maincent, P., 867
 Malcolm, D. S., 91, 819
 Malinoff, S. H., 1287
 Manjula, B. N., 695, 747
 Manning, J. M., 199
 Marden, M., 733, 739
 Margonari, J., 1455
 Marshall, T., 917
 Martin, L., 1355
 Mason, R. P., 1141, 1361
 Matsuda, N., 559, 939
 Mattrey, R. F., 295, 1449, 1477, 1491,
 1501
 Meinert, H., 1231
 Meloni, C., 109
 Menger, M. D., 587
 Menon, K., 827
 Menu, P., 543, 551
 Mercuriali, F., 245
 Mertens, K., 577
 Meschini, L., 109
 Messmer, K., 587
 Milius, A., 1273
 Millard, R. W., 235, 1029, 1243, 1251
 Morizawa, K., 901
 Morosetti, M., 109
 Morosetti, P., 109
 Motoki, R., 503
 Motterlini, R., 517, 565

N

Nakai, K., 559, 939
 Nakazato, Y., 939
 Nalcioğlu, O., 1449
 Nath, K., 207
 Nelson, D., 917, 923
 Nesti, F. D., 1377

Nho, K., 535, 657, 795, 805
Ni, Y., 1299, 1307
Nishide, H., 651, 855, 861, 895, 933
Nishiya, T., 883
Nolte, D., 587
Norcross, E. D., 955
Northey, D., 1369
Novotny, W., 1377
Null, D. M., 1381

O

Obraztsov, V. V., 1019, 1259, 1331
Ogata, Y., 875
Ogilby, J. D., 1083
Ohsaki, K., 875
Ohta, T., 559, 939
Olah, A., 965
Oleksiak, C. B., 1325
Oliver, S. R., 1237
Olsen, K. W., 709, 719
Olson, J. S., 429
Ota, K., 789
Otto, S., 1169, 1199
Oxynoid, O. E., 1331

P

Pacifico, A. D., 979
Paczan, P., 1377
Pagnier, J., 733, 739
Panter, S. S., 399
Papo, M. C., 1133, 1377
Parent, A., 1389
Pavia, A. A., 1485
Pello, M. J., 955
Pelura, T. J., 1169, 1205, 1287, 1299,
1307
Pereira, D., 923
Perrot Minnot, A., 71
Peters, R. M., 1161, 1511
Phillips, W. T., 909

Picken, J., 701
Postel, M., 991, 1193
Powell, C., 819
Poyart, C., 733, 739
Pratt, R. G., 1029, 1243
Pucci, B., 1485
Putyatina, T. K., 1281

Q

Quellec, P., 669

R

Rao, M. J., 695
Rath, M., 1377
Rebello, S., 593, 603
Regan, R. F., 399
Reimer, K. A., 253
Resch, P., 1175
Rico-Lattes, I., 1007
Riess, J. G., 215, 991, 1183, 1193, 1267,
1273, 1403, 1421, 1455, 1485
Riffard, P., 543
Rigter, G., 577
Rockwell, S., 1097
Rohn, K., 701
Roig, M. G., 115
Rosano, H. L., 1325
Rose, C. M., 279
Roth, R. I., 387
Rovida, E., 517
Roy, R. P., 747
Rubenstein, S. D., 315
Rudofsky, U., 1463
Rudolph, A. S., 9, 347, 909

S

Saewert, D., 1429
Sakaguchi, K., 503, 875

- Sakai, H., 651, 861
 Sakas, D. E., 83
 Sakuma, I., 939
 Salman, N., 1377
 Salzberg, S., 769
 Samaja, M., 517
 Samaratunga, R. C., 1029
 Sanchez, V., 1421
 Sanders, J., 909
 Santaella, C., 1403
 Satoh, T., 901
 Saunders, H. B., 1491
 Scalamogna, R., 245
 Schell, R. M., 813
 Schmid-Schönbein, G. W., 1441
 Schneider, K., 695
 Schultz, S. C., 91, 819
 Schutt, E. A., 1169, 1199, 1205
 Schwartz, G. N., 1369
 Scoggin, C. H., 457
 Sekiguchi, S., 559, 901, 939
 Sekins, K. M., 1381, 1409
 Shaffer, T. H., 315, 1389, 1397, 1409
 Sharma, A. C., 593
 Shekhtman, D. G., 1259
 Shiferaw, Y., 1029, 1243
 Shih, D. T., 415
 Shoemaker, S. A., 457
 Shorr, J., 1429
 Shorr, R., 535, 657, 795, 805
 Shrewsbury, R. P., 1237
 Simoni, G., 525, 777
 Simoni, J., 525, 777
 Sklenar, T. A., 1307
 Slosberg, S., 657
 Smith, D. J., 1199, 1215
 Smith, P. K., 747
 Song, D., 1299, 1307
 Spence, R. K., 955, 965
 Spicuzza, J., 917
 Sponsler, E., 479
 Spruell, R. D., 979
 Srnak, A., 923
 Standaert, T. A., 1121
 Steinbach, G. C., 1501
 Steinhorn, D. M., 1133, 1377
 Stern, R. G., 315, 1409
 Strnat, C. A., 1199
 Suga, H., 789
 Sun, A., 43
 Suzuki, K., 503, 875
 Suzuki, M., 875
 Sydliarov, D. P., 1331
 Szesko, D., 657
- T
- Taccone Gallucci, M., 109
 Takahashi, T. A., 939
 Takeoka, S., 651, 861
 Tarara, T. E., 1287
 Tartar, V. M., 1477
 Teicher, B. A., 827, 1109, 1369
 Terasse, K., 861
 Tereshina, E. V., 1337
 Thomas, C., 1355
 Thomas, F., 867
 Thomas, S. R., 1029, 1243
 Thompson, A. E., 1377
 Tokuyama, S., 559, 901
 Tooley, R., 1389
 Trevino, L., 1193
 Trink, B., 769
 Truog, W. E., 1121
 Tsai, A. G., 841
 Tsuchida, E., 467, 559, 651, 855, 861,
 895, 901, 933
- U
- Usuba, A., 503
- V
- Vacek, I., 43
 Valla, A., 1193
 Vandegriff, K. D., 399, 443, 849

Varma, R., 159
Vassilidze, T. V., 965
Vercellotti, G. M., 207
Vicente, W. V. A., 979
Vierling, P., 1403
Vigneron, C., 543, 551, 867
Villa, V. O. M., 625
Vinci, A., 245
Voiglio, E. J., 1455

W

Walder, J., 27
Wallach, D. F. H., 849
Weeger, P., 1355
Weers, J. G., 991, 1169, 1175, 1205,
1317
Weiner, M., 763
Weis, C., 1397
Weiss, R. L., 965
White, L. G., 1237
Wibault, P., 1355
Winslow, R. M., 841, 849

Winter, D. C., 1381
Wolf, G. L., 285, 1429
Wolfson, M. R., 315, 1389, 1397, 1409
Wrigley, R., 1491

Y

Yaksh, T. L., 1169
Yan, P. O., 399
Yang, T., 709
Yu, W. P., 889
Yu, Y. J., 619

Z

Zarif, L., 1193, 1421, 1455, 1485
Zervas, N. T., 83
Zhang, J., 1243
Zheng, S., 487
Zheng, Y., 487
Zuck, T. F., 945

SUBJECT INDEX TO VOLUME 22

A

- Acellular resuscitative fluids, in vitro evaluation of mixtures of, 633-639
- Acute myocardial ischemia, effects of reperfusion with arterial blood on, 253-278
- Adrenergic mechanisms, involvement of in the pressor effect of DCLHb, 603-612
- Affinity-directed $\beta\beta$ cross-linkers, of hemoglobin A, bisulfosuccinimidyl esters of aliphatic dicarboxylic acids as, 747-752
- Airway resistance, variation in with different perfluorochemical liquids, for neonatal endotracheal tubes, 1397-1402
- Alginate-poly-L-lysine-alginate (APA), the relationship between the membrane strength and the reaction conditions of biomicrocapsules of, 43-69
- Alginate/polylysine membranes, variations of the mannuronic or guluronic content of the polysaccharides of, FT-IR spectra of, 71-82
- Amphiphilic sugar phosphates, with single or double perfluoroalkylated hydrophobic chains, for use in oxygen and drug delivery systems, 1273-1279
- Anti-hypertensive agents, control of pressor effect of DCLHb by, 819-825
- Anti-xeno-antibodies, removal of by whole body rinse-out with hemoglobin solution, effectiveness of in xenotransplantation, 789-794
- Antioxidant defenses, induction of in the endothelium by heme, 207-213
- APA. *See* Alginate-poly-L-lysine-alginate
- Aqueous two-phase system, application of in separation/purification of stroma-free hemoglobin from animal blood, 641-649
- Autologous blood transfusion protocols, the potential role of oxygen-carrying products in, 245-251
- Autoxidation, enzymatic protection from for cross-linked hemoglobins, 709-717

B

- Biocompatibility, of perfluorodecalin emulsion in macrophages, testing for by a magnetometric method, 1231-1236
- Biomaterial-tissue interfaces (book review), 119-120
- Biomedicine, design and development of fluorocarbon-based products for use in, 215-234

- Biomicrocapsules, APA, relationship between the membrane strength and the reaction conditions of, 43-69
- Bis(3,5-dibromosalicyl) fumarate α - α cross-linked hemoglobin
- blood substitution with, influence of functional capillary density changes on oxygen delivery during, 841-847
 - enhanced oxidation of by free radicals generated by xanthine/xanthine oxidase, 517-524
 - vasoconstrictor effects in isolated rabbit heart perfused with, 565-575
- Bissulfosuccinimidyl esters, of aliphatic dicarboxylic acids, as a new class of affinity-directed $\beta\beta$ cross-linkers of hemoglobin A, 747-752
- Blood flow distribution, during infusion of perflubron emulsion or its vehicle in anesthetized dogs, 1343-1353
- Blood half-life, influence of perflubron emulsion particle size on in rats, 1169-1174
- Blood substitutes
- applications of for military trauma, 145-157
 - assessment of
 - efficacy of in anesthetized and conscious rats with varying blood volume loss, 159-169
 - in vitro complement activation of human plasma and blood by, 171-180
 - efficacy of, difficulties in demonstrating, 945-953
 - fluorocarbon, in Russia, 1019-1027
 - hemodilution and, 137-144
 - hemoglobin based, genetic engineering of myoglobin as a prototype for, 429-441
 - perfluorocarbon emulsion, oxygen solubility, rheology, and hemodynamics of, 235-244
- perfluorocarbons as
- experience with Fluosol DA-20% in the 1980s, 955-963
 - pharmacokinetics and side effects of, 1043-1054
 - phospholipid stabilized
 - perfluorocarbon based, oxidative assessment of, 1287-1293
 - submicron biodegradable polymer membrane hemoglobin nanocapsules as, 889-893
- Blood volume loss, varying amounts of in anesthetized and conscious rats, assessment of efficacy of blood substitutes in, 159-169
- Brain injury, ischemic, effects of lecithin-emulsified perfluorochemical compounds in, 83-89
- Buffer pH, effects of on the droplet size and egg yolk phospholipid hydrolysis of perflubron/egg yolk phospholipid emulsions, 1299-1305

C

Cancer

- chemotherapy for, combination of perfluorochemical emulsions and carbogen breathing with, 1109-1120
 - and hypoxia, overview of the session on at the Fifth International Symposium on Blood Substitutes, 279-284
 - perfluorochemical emulsions and radiation therapy for, 1097-1108
 - staging of, role of imaging and contrasts in, 285-294
- Capillary density changes, functional, influence of on oxygen delivery during blood substitution with

- α - α hemoglobin and dextran 70, 841-847
- Carbogen, tumor oxygenation after administration of in tumor xenografts and in patients, 1355-1360
- Carbogen breathing, and perfluorochemical emulsions combination of with cancer chemotherapy, 1109-1120
- oxygenation of human tumor xenografts in nude mice by, 1369-1375
- Carboxylate dextran, human hemoglobin conjugated to methemoglobin formation after administration of, 551-558
- as a potential red blood cell substitute pharmacotoxicological evaluation of, 543-549
- physicochemical characterization of, 669-676
- Carboxymethyl chitin, use of to reduce toxicity of liposomes containing low mol% of dienoil phosphocholine to blood, 883-888
- Cardiac surgery, use of current generation perfluorocarbon emulsions in, 979-990
- Cardiovascular applications, of fluorocarbons
- current status and future direction, 1083-1096
- in regional ischemia/reperfusion, 1069-1081
- Chimeric hemoglobin subunits, recombinant β/α hemoglobin, functional properties of, 733-738
- Chloride binding sites, role of in control of oxygen affinity, determination of by random chemical modification of hemoglobin, 199-205
- Coagulation responses, of human plasma after hemodilution with hemoglobin solution in vitro, 613-618
- Coalescence, of concentrated fluorocarbon emulsions with large-size droplets, protection against by mixed fluorocarbon/hydrocarbon molecular dowels, 1267-1272
- Colloidal particles, perfluorocarbon emulsion, intracellular and extracellular transport of from subcutaneous tissue to regional lymphatics, 1441-1447
- Complement activation, of human plasma and blood in vitro, assessment of blood substitutes for, 171-180
- Contaminants, associated with hemoglobin, effect of on release of cytokines and platelet-activating factor from human monocytes and macrophages, 525-534
- Contrast agents
- blood pool, Imagent BP as, for visualization and quantitation of liver tumor burden, 1501-1509
- injectable fluorinated, with enhanced radiopacity, 1421-1428
- role of in the staging of cancer, 285-294
- Cooley's anemia, isolated ultrafiltration for refractory heart failure in patients with, 109-113
- Cooperativity, influence of polymerization on during production of hyperpolymers, 725-731
- Cosmetics, application of fluorocarbon emulsions as components of, 1331-1336
- α - α Cross-linked hemoglobin, neurotoxicity dependent on, 399-413
- Cross-linking
- of hemoglobin
- with different length reagents, thermal stabilities of, 719-724
- by molecular clamps, 415-428
- with solid-phase supports, of encapsulated hemoglobin, 479-485

- Cytochrome P4502D6 activity, effect of moderate hemodilution with Fluosol on, 1237-1242
- Cytokines, effect of hemoglobin and contaminants on release of from human monocytes and macrophages, 525-534

D

- DCLHb™. *See* α - α Diasprin cross-linked hemoglobin
- Dextran 70, blood substitution with, influence of functional capillary density changes on oxygen delivery during, 841-847
- Diagnostic imaging, potential role of perfluorochemicals in, 295-313
- α - α Diasprin cross-linked hemoglobin (DCLHb)
- bioanalytical studies of in swine, 917-922
 - characterization of the process and the product manufactured under GMP requirements for clinical studies, 701-708
 - control of pressor effect of with anti-hypertensive agents, 819-825
 - effect of hemodilution with during focal cerebral ischemia in rats, 813-818
 - effects of on the microcirculation of striated muscle, 587-592
 - hypertensive response to, nitric oxide as a mediator of in rats, 1-7
 - intravenous, characterization of the hemodynamic response to in rats, 91-107
 - polymerization of, 923-931
 - pressor effect of, involvement of adrenergic mechanisms in, 603-612
 - regional circulatory and systemic hemodynamic effects of in the rat,

- 593-602
- Differentiation, of Friend erythroleukemic cells in vitro, the role of interferon-induced proteins in, 769-775
- Divinyl sulfone, as a source for oxygen carriers by anaerobic reaction with human hemoglobin, 687-693
- Divinyl-sulfone-reacted bovine hemoglobin, structural and oxygen-binding properties of as a function of protein ligation state and reactant concentration, 677-686
- Drug delivery systems
 - amphiphilic sugar phosphates with single or double perfluoroalkylated hydrophobic chains for use in, 1273-1279
 - double-tailed perfluoroalkylated glycolipids as components for, 1485-1490
 - fluorinated phospholipid-based vesicles as, 1403-1408

E

- ECMO. *See* Extracorporeal membrane oxygenation
- Efficacy, of blood substitutes, difficulties in demonstration of, 945-953
- Egg yolk phospholipids
- perflubron concentrated emulsions with, stability of, 1325-1330
 - perfluorocarbon emulsions stabilized with, elimination peculiarities of, 1281-1285
- Elimination, of perfluorocarbon emulsions stabilized with egg yolk phospholipid, 1281-1285
- Encapsulation
- of hemoglobin in nonphospholipid vesicles, 849-854
 - procedure, for hemoglobin vesicles, 861-866

- Endothelial cells, human, reaction of to bovine hemoglobin solutions and tumor necrosis factor, 777-787
- Endothelium, heme as inducer of antioxidant defenses in, 207-213
- Endotracheal tubes, neonatal, variation in airway resistance to with different perfluorochemical liquids, 1397-1402
- Enzymes, use of to protect cross-linked hemoglobins from autoxidation, 709-717
- Erythrocytes, and acellular fluid mixtures, evaluation of in vitro, 633-639
- Escherichia coli*, synthesis of β (NA1)Val-deleted,(NA2)HisTM et hemoglobin in, functional properties of, 739-745
- Exchange transfusion models, rat, PEG-Hb as an efficient oxygen-delivery system in, 795-803
- Extracorporeal membrane oxygenation (ECMO), improved pulmonary function and gas exchange during by lung management with perfluorocarbon liquid ventilation, 1389-1396
- F
- Fatty acid derivative, long chain, intravascular retention of hemoglobin modified with, 27-42
- Febrile response, influence of perflubron emulsion particle size on in rats, 1169-1174
- Fluorocarbon-based products, design and development of for use in medicine and biology, 215-234
- Fluorocarbon blood substitutes, in Russia, 1019-1027
- Fluorocarbon emulsions
- analysis of Ostwald ripening in by sedimentation field-flow fractionation, 1317-1323
- application of as components of cosmetics and medical ointments, 1331-1336
- concentrated, improved control over particle sizes and stability of by use of mixed fluorocarbon/hydrocarbon molecular dowels, 1183-1191
- with large-size droplets, protection against coalescence of by mixed fluorocarbon/hydrocarbon molecular dowels, 1267-1272
- long-term room temperature stability of, 991-1005
- lung functions after intravenous or intraperitoneal administration of, 1251-1258
- Fluorocarbons, cardiovascular applications of
- current status and future direction of, 1083-1096
- in regional ischemia/reperfusion, 1069-1081
- Fluorochemicals, for oxygen transport and delivery, mechanisms and efficacy of, 181-197
- Fluosolt®
- DA-20%, experience with as blood substitute in the 1980s, 955-963
- moderate hemodilution with, effect of on cytochrome P4502D6 activity in the rat, 1237-1242
- Formulation parameters, effects of on the characteristics and stability of perflubron emulsion, 1307-1315
- Fourier transform-infrared (FT-IR) spectra, of polylysine/alginate membranes with various contents of mannuronic or guluronic acid, 71-82

Friend erythroleukemic cells, role of
interferon-induced proteins in the
differentiation of in vitro, 769-775
FT-IR. *See* Fourier transform-infrared
Full-tidal liquid ventilation, with
perfluorocarbon, for prevention of
lung injury in newborn
non-human primates, 1121-1132

G

Ganglioside G_{M1}, inclusion of into LEH,
relation of to circulation
persistence, 9-25
Gas exchange, improvement of during
ECMO by lung management with
perfluorocarbon liquid ventilation,
1389-1396
Genetic engineering
of myoglobin as a simple prototype
for hemoglobin-based blood sub-
stitutes, 429-441
of recombinant human hemoglobin,
rationally designed, initial clinical
experience with, 457-465
Glycolipids, double tailed
perfluoroalkylated, as components
for drug delivery and targeting
systems, 1485-1490
GMP. *See* Good Manufacturing Practice
Good Manufacturing Practice (GMP),
characterization of the process
and the DCLHb manufactured
under for clinical studies, 701-708

H

Heart failure, refractory, in patients with
Cooley's anemia, isolated ultrafil-
tration for, 109-113
Heme, as inducer of antioxidant defenses
in the endothelium, 207-213

Heme exchange rates, for
site-specifically cross-linked ver-
sus polymerized human
hemoglobins, comparison of,
443-455
Hemodilution
acute, enhanced oxygen delivery by
perflubron emulsion during,
1161-1167
and blood substitutes, 137-144
canine surgical, improvement in circu-
latory and oxygenation status by
perflubron (Oxygent HT) in,
965-977
with DCLHb, effect of during focal
cerebral ischemia in rats, 813-818
with hemoglobin solution in vitro, co-
agulation responses of human
plasma after, 613-618
moderate, with Fluosol, effect of on
cytochrome P4502D6 activity in
the rat, 1237-1242
Hemodynamic response
central, during infusion of perflubron
emulsion or its vehicle in anesthe-
tized dogs, 1343-1353
to intravenous DCLHb solution in rats,
91-107
regional circulatory and systemic, ef-
fects of DCLHb on in the rat,
593-602
Hemoglobin
acellular and cellular solutions of as
vasoconstrictive factor, 559-564
anaerobically reacted with divinyl sul-
fone, as a source for oxygen car-
riers, 687-693
cross-linked
with different length reagents, ther-
mal stabilities of, 719-724
use of enzymes for protection of
against autoxidation, 709-
717
cross-linking of by molecular clamps,
415-428

- denatured, increase of human blood mononuclear cell procoagulant effect by, 625-631
- divinyl sulfone reacted bovine, structural and oxygen-binding properties of, 677-686
- effect of on release of cytokine and platelet-activating factor from human monocytes and macrophages, 525-534
- encapsulated
 - cross-linking of with solid-phase supports, 479-485
 - in nonphospholipid vesicles, 849-854
- as an enhancer of lipopolysaccharide biological activity, 387-398
- liposome encapsulated
 - current issues and future goals of, 347-360
 - relation of inclusion of ganglioside G_{M1} in to circulation persistence, 9-25
 - sterically stabilized, efficacy, physical properties, and pharmacokinetics of, 487-501
 - technetium-99m labeled, circulation profile of in a 10% or 50% rat hypovolemic shock model, 909-915
- modified
 - with a long-chain fatty acid derivative, prolongation of the intravascular retention of, 27-42
 - redox reactivity of with hydrogen peroxide and nitric oxide, toxicological implications of, 373-386
- PEG modified
 - bovine, economics and feasibility of production of, 657-667
 - as an efficient oxygen-delivery system in the rat exchange transfusion and hypovolemic shock models, 795-803
 - hemoglobinuria as a test of renal filtering and absorption of, 535-541
 - restoration of normal oxygen tension in the ischemic rat liver model by, 805-812
 - purification of, 651-656
 - random chemical modification of for identification of chloride binding sites to determine their role in oxygen affinity, 199-205
 - recombinant human, initial clinical experience with, 457-465
 - site specifically cross-linked versus polymerized human, comparison of heme exchange rates of, 443-455
 - solubility of, method for determining, 753-761
- solutions
 - bovine, reaction of human endothelial cells to, 777-787
 - hemomodulation with in vitro, coagulation responses of human plasma after, 613-618
 - in vitro safety testing of by measurement of interleukin-6 production by monocytes, 835-840
 - oxygenation of the rat 9L gliosarcoma and the rat 13672 mammary carcinoma with various doses of, 827-833
 - test model for prevention of side effects by, 577-585
 - whole body rinse-out with, for investigation of the effectiveness of the removal of anti-xeno-antibodies by, 789-794
- stroma free
 - as an enhancer of lipopolysaccharide activity, 387-398
 - quality control of, 939-944
 - separation/purification of from animal blood by application of aqueous two-phase system, 641-649

- Hemoglobin A
 bisulfosuccinimidyl esters of aliphatic dicarboxylic acids as a new class of affinity-directed $\beta\beta$ cross-linkers of, 747-752
 recombinant human produced in transgenic swine, structural equivalence of with human hemoglobin A, 695-700
- Hemoglobin iron, a nonradioactive method for tracing of, 619-624
- Hemoglobin vesicles
 characteristics of and encapsulation procedure for, 861-866
 nonphospholipid, 849-854
 stabilized, 467-477
- Hemoglobinuria, as a test of renal filtering and absorption of PEG-hemoglobin, 535-541
- Hemorrhagic shock, canine, effect of neo red cells on hemodynamics, blood gas transport, and safety of vital organs in, 503-516
- Hydrogen peroxide, redox reactivity of modified hemoglobins with, 373-386
- Hyperpolymers, from native hemoglobins with cross-linkers, influence of polymerization on oxygen affinity and cooperativity during production of, 725-731
- Hypertensive response, to a modified hemoglobin solution (DCLHb), nitric oxide as a mediator of in rats, 1-7
- Hypovolemic shock models, rat
 PEG-Hb as an efficient oxygen-delivery system in, 795-803
 10% or 50%, circulation profile of technetium-99m labeled liposome encapsulated hemoglobin in, 909-915
- Hypoxia, and cancer, overview of the session on at the Fifth International Symposium on Blood Substitutes, 279-284
- I
- Imagent® BP
 as a blood pool contrast agent to visualize and quantitate liver tumor burden, 1501-1509
 efficacy of at 1.5 ml/kg in a rabbit liver tumor model, 1491-1499
- Imaging agents, role of in the staging of cancer, 285-294
- Immobilization, a misleading experimental protocol in the field of, 115-117
- Interferon-induced proteins, role of in the differentiation of Friend erythroleukemic cells in vitro, 769-775
- Interleukin-6 production, measurement of by monocytes for in vitro safety testing of hemoglobin solutions, 835-840
- Intravascular retention, of hemoglobin modified with a long-chain fatty acid derivative, 27-42
- Iron-58, neutron activation analysis of, as a nonradioactive method for tracing hemoglobin iron, 619-624
- Ischemia
 acute myocardial, effects of reperfusion with arterial blood on, 253-278
 cerebral, effects of lecithin-emulsified perfluorochemical compounds in, 83-89
 focal cerebral, effect of hemodilution with DCLHb during, 813-818
 in the rat liver model, restoration of normal oxygen tension in by PEG-Hb, 805-812
 regional, cardiovascular applications of

fluorocarbons in, 1069-1081

L

- LEH. *See* Lipome encapsulated hemoglobin
- Lipid absorption, by perfluorochemical emulsions, effect of in the bloodstream and perspectives of its clinical application, 1337-1342
- Lipidheme-microsphere
structure and solution properties of, 855-860
as totally artificial red blood cell substitute, 895-900
as totally synthetic oxygen carrier, and oxygen-carrying ability of, 933-938
- Lipopolysaccharide, enhancement of biological activity of by hemoglobin, 387-398
- Lipoproteins, of plasma blood, effect of perfluorochemical emulsion on, 1295-1298
- Liposome embedded heme, as a totally artificial red blood cell substitute, 895-900
- Liposome encapsulated hemoglobin (LEH)
current issues and future goals of, 347-360
relation of inclusion of ganglioside G_{M1} in to circulation persistence, 9-25
sterically stabilized, efficacy, physical properties, and pharmacokinetics of, 487-501
technetium-99m labeled, circulation profile of in a 10% or 50% rat hypovolemic shock model, 909-915
- Liposomes, containing low mol% of dioleoyl phosphocholine to blood, use of carboxymethyl chitin to reduce toxicity of, 883-888
- Liquid fluorocarbon pads (Sat Pads), reduction of magnetic susceptibility differences using, 1477-1483
- Liquid ventilation
full-tidal with perflubron, for prevention of lung injury in newborn non-human primates, 1121-1132
long term partial, with perflubron in the near-term baboon neonate, 1381-1387
with perfluorocarbon, lung management of improves pulmonary function and gas exchange during ECMO, 1389-1396
- Liver detoxification enzymes, effect of perfluorochemicals on, 1259-1266
- Liver tumors
imaging efficacy of with Imagent BP at 1.5 ml/kg, 1491-1499
visualization and quantitation of using Imagent BP as a blood pool contrast agent, 1501-1509
- Lung
functions, after intravenous or intraperitoneal administration of perfluorooctyl bromide or perfluorotributylamine emulsions, 1251-1258
injury, in newborn non-human primates, full-tidal liquid ventilation with perfluorocarbon for prevention of, 1121-1132
oxygenation of during PAGE, 1377-1380
perfluorocarbon filled, gas ventilation in for PAGE, 1133-1139
- Lymph node imaging, using perflubron emulsion, preclinical and clinical studies of, 1429-1439
- Lysophosphatidylcholine, as candidate vasoconstrictive factor in stroma-free hemoglobin, 939-944

M

- Magnetic susceptibility differences, reduction of using liquid fluorocarbon pads (Sat Pads), results with spectral presaturation of fat, 1477-1483
- Magnetometry, testing of
perfluorodecalin emulsion by, for biocompatibility in macrophages, 1231-1236
- Medical ointments, application of fluorocarbon emulsions as components of, 1331-1336
- Membranes, alginate/polylysine with various contents of mannuronic or guluronic acid, FT-IR spectra of, 71-82
- Mesenteric artery occlusion shock, influence of perflubron on the creation of oxygen free radical products in, 1223-1230
- Methemoglobin, formation of after administration of hemoglobin conjugated to carboxylate dextran, in guinea pigs, 551-558
- Microcirculation
effects of hemodilution with blood substitutes on, 137-144
of striated muscle, evaluation of the effects of DCLHb on, 587-592
- Microemulsions, of perfluorinated and semi-fluorinated compounds, 1007-1018
- Microspheres
lipidheme
structure and solution properties of, 855-860
as totally artificial red blood cell substitute, 895-900
as totally synthetic oxygen carrier and oxygen-carrying ability of, 933-938
poly(lactic acid) hemoglobin, preparation and characterization of, 867-873
- Military trauma, applications of blood substitutes for, 145-157
- Molecular clamps, used for cross-linking hemoglobin, 415-428
- Molecular dowels, mixed fluorocarbon/hydrocarbon
emulsions, biodistribution and excretion of as determined by ^{19}F nuclear magnetic resonance, 1193-1198
improved control over particle sizes and stability of concentrated fluorocarbon emulsions by use of, 1183-1191
protection against coalescence by, of concentrated fluorocarbon emulsions with large-size droplets 1267-1272
- Monocytes
human cell line, phagocytosis of a fluorescently labeled perflubron emulsion by, 1215-1221
measurement of interleukin-6 production by, for in vitro safety testing of hemoglobin solutions, 835-840
- Mononuclear cell procoagulant effect, increase of with denatured hemoglobin, 625-631
- Multiple organ blocks, normothermic preservation of with perfluorooctyl bromide emulsion, 1455-1461
- Muscle, striated, evaluation of the effects of DCLHb on the microcirculation of, 587-592
- Myoglobin, genetic engineering of as a simple prototype for hemoglobin-based blood substitutes, 429-441

N

Nanocapsules, submicron biodegradable

polymer membrane hemoglobin,
as potential blood substitutes,
889-893

Neo red cells
effect of on hemodynamics and blood
gas transport in canine hemor-
rhagic shock and its safety for
vital organs, 503-516
in vivo studies of the characteristics,
function, and safety of, 875-881

Neurotoxicity, α - α cross-linked hemo-
globin dependent, 399-413

Neutron activation analysis, for iron-58,
as a nonradioactive method for
tracing hemoglobin iron, 619-624

Nitric oxide
as mediator of the hypertensive re-
sponse to a modified hemoglobin
solution (DCLHb) in rats, 1-7
redox reactivity of modified
hemoglobins with, 373-386

Noninvasive physiology, by ^{19}F nuclear
magnetic resonance of
perfluorocarbons, 1141-1153

Nonphospholipid vesicles, encapsulation
of hemoglobin in, 849-854

Nuclear magnetic resonance
 ^{19}F
determination of biodistribution and
excretion of a mixed fluorocar-
bon/hydrocarbon dowl emulsion
by, 1193-1198
of perfluorocarbon distribution to
liver, lung, and spleen, 1243-
1250
of perfluorocarbons for noninvasive
physiology, 1141-1153
use of Oxygent as a probe for, mea-
surement of tumor oxygen tension
by, 1361-1367
functional, of a metabolite of $^{17}\text{O}_2$,
1055-1068
perfluorocarbon F-19, quantitative pO_2
imaging in vivo with, 1029-
1042

O

Organ preservation
issues and problems of in the United
States, 327-346
normothermal, with perfluorooctyl
bromide emulsion, 1455-1461
postmortem, using an Oxygent supple-
mented perfusate, 1469-1475
without extreme hypothermia, using an
Oxygent supplemented perfusate,
1463-1468

Ostwald ripening, in fluorocarbon emul-
sions, analysis of by sedimenta-
tion field-flow fractionation,
1317-1323

Oxidation
enhanced, of bis(3,5-dibromosalicyl)
fumarate α - α cross-linked hemo-
globin by free radicals generated
by xanthine/xanthine oxidase,
517-524
of hemoglobin, attempts to prevent,
551-558

Oxidative assessment, of
phospholipid-stabilized
perfluorocarbon-based blood sub-
stitutes, 1287-1293

Oxygen
delivery
amphiphilic sugar phosphates with
single or double
perfluoroalkylated hydrophobic
chains for, 1273-1279
concepts of tissue pO_2 in relation to,
763-768
influence of functional capillary
density changes on, during
blood substitution with $\alpha\alpha$ hemo-
globin and dextran 70, 841-
847
PEG-Hb for in the rat exchange
transfusion and hypovolemic
shock models, 795-803
by perflubron emulsion during acute

[Oxygen *continued*]

- hemodilution, 1161-1167
- fluorochemical transport and delivery of, mechanisms and efficacy of, 181-197
- solubility, rheology, and hemodynamics of, for perfluorocarbon emulsion blood substitutes, 235-244
- tracking of by quantitative pO₂ imaging in vivo with perfluorocarbon F-19 nuclear magnetic resonance, 1029-1042
- transport, of artificial red cells, 901-907
- Oxygen affinity
 - influence of polymerization on during production of hyperpolymers, 725-731
 - role of chloride binding sites in control of, random chemical modification of hemoglobin to identify, 199-205
- Oxygen carriers
 - hemoglobin based, increased vascular resistance with, 361-372
 - human hemoglobin anaerobically reacted with divinyl sulfone as a source for, 687-693
 - lipidheme-microsphere as, 933-938
 - potential role of in autologous blood transfusion protocols, 245-251
 - and transfusion medicine, 123-135
- Oxygen free radical products, influence of perflubron on the creation of in mesenteric artery occlusion shock, 1223-1230
- Oxygen tension, normal, restoration of in the ischemic rat liver model by PEG-Hb, 805-812
- Oxygenation
 - during perfluorocarbon associated gas exchange in normal and abnormal lungs, 1377-1380
 - by a perfluorochemical emulsion and carbogen breathing, for human

- tumor xenografts in nude mice, 1369-1375
- of the rat 9L gliosarcoma and the rat 13672 mammary carcinoma with various doses of a hemoglobin solution, 827-833
- Oxygent™
 - as a ¹⁹F nuclear magnetic resonance probe at 4.7 T, measurement of tumor oxygen tension by, 1361-1367
 - perfusate supplemented with for organ preservation without extreme hypothermia, 1463-1468
 - postmortem organ salvage using, 1469-1475
- Oxygent™ CA, pharmacokinetics and tolerance of weekly infusions of in the dog, 1155-1160
- Oxygent™ HT
 - improvement in circulatory and oxygenation status by in a canine model of surgical hemodilution, 965-977
 - side effects of, characterization and mechanism of in swine, 1511-1515

P

- PAGE. *See* Perfluorocarbon associated gas exchange
- Partial liquid ventilation, long term, with perflubron in the near-term baboon neonate, 1381-1387
- Particle size
 - of concentrated fluorocarbon emulsions, improved control over by use of mixed fluorocarbon/hydrocarbon molecular dowers, 1183-1191
 - large, protection of coalescence of in concentrated fluorocarbon emulsions by mixed fluorocar-

- bon/hydrocarbon molecular dows, 1267-1272
- of perflubron emulsions, influence of on blood half-life and febrile response in rats, 1169-1174
- PEG-Hb. *See* Polyethylene glycol hemoglobin
- Perflubron/egg yolk phospholipid emulsions, effects of buffer pH and phosphate concentration on the droplet size and egg yolk phospholipid hydrolysis of, 1299-1305
- Perflubron emulsions
- concentrated, in aqueous media, stability of with egg yolk phospholipids, 1325-1330
 - effects of formulation, processing, and storage parameters on the characteristics and stability of, 1307-1315
 - enhanced oxygen delivery by during acute hemodilution, 1161-1167
 - fluorescently labeled, phagocytosis of by a human monocyte cell line, 1215-1221
 - influence of on the creation of oxygen free radical products in mesenteric artery occlusion shock, 1223-1230
 - infusion of in anesthetized dogs, central hemodynamics and blood flow distribution during, 1343-1353
 - long-term partial liquid ventilation with, in the near-term baboon neonate, 1381-1387
 - for lymph node imaging, preclinical and clinical studies on, 1429-1439
- Oxygen CA, pharmacokinetics and tolerance of weekly infusions of in the dog, 1155-1160
- Oxygent HT, improvement in circulatory and oxygenation status by in a canine model of surgical hemodilution, 965-977
- particle size of, influence of on blood half-life and febrile response in rats, 1169-1174
- tumor oxygenation after administration of in tumor xenografts, 1355-1360
- use of in cardiac surgery, 979-990
- Perfluorinated compounds, microemulsions of, 1007-1018
- Perfluorocarbon associated gas exchange (PAGE)
- oxygenation during, in normal and abnormal lungs, 1377-1380
 - relating to the gas ventilation of the perfluorocarbon filled lung, 1133-1139
- Perfluorocarbon emulsion blood substitutes, oxygen solubility, rheology, and hemodynamics of, 235-244
- Perfluorocarbon F-19 nuclear magnetic resonance, quantitative pO₂ imaging in vivo with, 1029-1042
- Perfluorocarbons
- blood substitutes based on in the 1980s, experience with Fluosol DA-20%, 955-963
 - pharmacokinetics and side effects of, 1043-1054
- emulsions
- in cardiac surgery, 979-990
 - intracellular and extracellular transport of from subcutaneous tissue to regional lymphatics, 1441-1447
 - intravenous infusion of, PGT differences among animal species in response to, 1199-1204
 - proposed mechanism of PGT following intravenous administration of, 1205-1214
 - room temperature stable, with acceptable half-lives in the reticuloendothelial system, 1175-1182
 - stabilized with egg yolk phospholipid, elimination peculiar-

[Perfluorocarbons *continued*]

- ties of, 1281-1285
- ¹⁹F nuclear magnetic resonance of
 - for distribution of to liver, lung, and spleen, 1243-1250
 - for noninvasive physiology, 1141-1153
- full-tidal liquid ventilation with, for prevention of lung injury in newborn non-human primates, 1121-1132
- Perfluorochemical emulsions
 - and carbogen breathing
 - combination of with cancer chemotherapy, 1109-1120
 - oxygenation of human tumor xenografts in nude mice by, 1369-1375
 - effect of on lipoproteins of plasma blood, 1295-1298
 - and radiation therapy, 1097-1108
- Perfluorochemicals (PFCs)
 - as cause of variation in airway resistance, for neonatal endotracheal tubes, 1397-1402
 - compounds, lecithin emulsified, effects of in ischemic brain injury, 83-89
 - effect of on liver detoxification enzymes, 1259-1266
 - lipid absorption by, effect of in the bloodstream and its clinical application, 1337-1342
 - liquid
 - for pulmonary diagnostic imaging, 1409-1420
 - as a respiratory medium, 315-326
 - potential role of in diagnostic imaging, 295-313
- Perfluorodecalin emulsion, testing of for biocompatibility in macrophages by a magnetometric method, 1231-1236
- Perfluorooctyl bromide emulsion, normothermic preservation of multiple organ blocks with, 1455-1461

- PFCs. *See* Perfluorochemicals
- PGT. *See* Pulmonary gas trapping
- Phagocytosis, of a fluorescently labeled perflubron emulsion by a human monocyte cell line, 1215-1221
- Phosphate concentration, effects of on the droplet size and egg yolk phospholipid hydrolysis of perflubron/egg yolk phospholipid emulsions, 1299-1305
- Phospholipid-based vesicles, fluorinated, as potential drug carriers, 1403-1408
- Phospholipid-stabilized
 - perfluorocarbon-based blood substitutes, oxidative assessment of, 1287-1293
- Plasma, effect of perfluorochemical emulsion on lipoproteins of, 1295-1298
- Platelet-activating factor, effect of hemoglobin and contaminants on release of from human monocytes and macrophages, 525-534
- pO₂, monitoring of by spin-spin relaxation rate 1/T₂ of ¹⁹F in a rabbit abscess model, 1449-1454
- Poly(lactic acid) hemoglobin
 - microspheres, preparation and characterization of, 867-873
- Polyester foam, as an immobilization method for enzymes and proteins, 115-117
- Polyethylene glycol hemoglobin (PEG-Hb)
 - bovine, economics and feasibility of production of, 657-667
 - as an efficient oxygen-delivery system in the rat exchange transfusion and hypovolemic shock models, 795-803
 - renal filtering and absorption of, hemoglobinuria as a test of, 535-541
 - restoration of normal oxygen tension in the ischemic rat liver model

- by, 805-812
- Polymer membrane hemoglobin
nanocapsules, submicron biodegradable, as potential blood substitutes, 889-893
- Polymerization
of DCLHb, 923-931
influence of on oxygen affinity and cooperativity during production of hyperpolymers from native hemoglobins with cross-linkers, 725-731
- Pressor effect, of DCLHb
control of with anti-hypertensive agents, 819-825
involvement of adrenergic mechanisms in, 603-612
- Processing parameters, effects of on the characteristics and stability of perflubron emulsion, 1307-1315
- Procoagulant effect, of human blood mononuclear cells, increase of with denatured hemoglobin administration, 625-631
- Protein ligation state, structural and oxygen-binding properties of divinyl-sulfone-reacted bovine hemoglobin as a function of, 677-686
- Pulmonary diagnostic imaging, use of a perfluorochemical liquid for, 1409-1420
- Pulmonary function, improvement of during ECMO by lung management with perfluorocarbon liquid ventilation, 1389-1396
- Pulmonary gas trapping (PGT)
differences of among animal species in response to intravenous infusion of perfluorocarbon emulsions, 1199-1204
proposed mechanism of, following intravenous perfluorocarbon emulsion administration, 1205-1214
- Purification, of hemoglobin, convenient method of, 651-656
- R
- Radiation therapy, perfluorochemical emulsions and, 1097-1108
- Radiopacity, enhanced, injectable fluorinated contrast agents with, 1421-1428
- Reactant concentration, structural and oxygen-binding properties of divinyl-sulfone-reacted bovine hemoglobin as a function of, 677-686
- Reactive oxygen metabolite, functional magnetic resonance imaging of, 1055-1068
- Recombinant β/α hemoglobin, functional properties of, 733-738
- Recombinant human hemoglobin, rationally designed and genetically engineered, initial clinical experience with, 457-465
- Red blood cell substitutes
human hemoglobin conjugated to carboxylate dextran as, pharmacotoxicological evaluation of, 543-549
physicochemical characterization of, 669-676
liposome embedded heme and lipidheme-microsphere as, 895-900
oxygen transport and in vivo parameters of, 901-907
- PEG-Hb as, hemoglobinuria as a test of renal filtering and absorption of, 535-541
- Redox reactivity, of modified hemoglobins with hydrogen peroxide and nitric oxide, toxicological implications of, 373-386
- Reperfusion
with arterial blood, effects of on acute

- [Reperfusion *continued*]
 myocardial ischemia, 253-278
 cardiovascular applications of fluorocarbons in
 current status and future direction of, 1083-1096
 for regional ischemia, 1069-1081
 Respiratory medium, perfluorochemical liquid as, 315-326
 Reticuloendothelial system, room temperature stable perfluorocarbon emulsions with acceptable half-lives in, 1175-1182

S

- Sat Pads™, use of for reduction of magnetic susceptibility differences, 1477-1483
 Sedimentation field-flow fractionation, analysis of Ostwald ripening in fluorocarbon emulsions by, 1317-1323
 Semi-fluorinated compounds, microemulsions of, 1007-1018
 Solid-phase supports, cross-linking encapsulated hemoglobin with, 479-485
 Solubility, determination of for hemoglobin and modified hemoglobins, 753-761
 Spin-spin relaxation rate, $1/T_2$ of ^{19}F , monitoring of $p\text{O}_2$ in a rabbit abscess model by, 1449-1454
 Stability
 of concentrated fluorocarbon emulsions, improved control over by use of mixed fluorocarbon/hydrocarbon molecular dowers, 1183-1191
 long term room temperature of fluorocarbon emulsions, 991-1005
 of perfluorocarbon emulsions, with acceptable half-lives in

- the reticuloendothelial system, 1175-1182
 Storage parameters, effects of on the characteristics and stability of perflubron emulsion, 1307-1315
 Stroma-free hemoglobin
 as an enhancer of lipopolysaccharide activity, 387-398
 quality control of, 939-944
 separation/purification of from animal blood by application of aqueous two-phase system, 641-649
 Subcutaneous tissue, intracellular and extracellular transport to regional lymphatics of perfluorocarbon emulsion, 1441-1447

T

- Targeting systems, double tailed perfluoroalkylated glycolipids as, 1485-1490
 Technetium-99m labeled liposome encapsulated hemoglobin, circulation profile of in a 10% or 50% rat hypovolemic shock model, 909-915
 Thermal stabilities, of hemoglobins cross-linked with different length reagents, 719-724
 Thrombogenicity, test model for prevention of in transfusions with hemoglobin solutions, 577-585
 Tissue $p\text{O}_2$, concepts of in relation to oxygen delivery, 763-768
 Toxicity, of liposomes containing low mol% of dienoyl phosphocholine to blood, reduction of by use of carboxymethyl chitin, 883-888
 Transfusion medicine, oxygen carriers and, 123-135
 Transfusion protocols, autologous blood, potential role of oxygen-carrying

- products in, 245-251
- Tumor necrosis factor, reaction of human endothelial cells to, 777-787
- Tumor oxygen tension, measurement of using Oxygent as a ^{19}F nuclear magnetic resonance probe at 4.7 T, 1361-1367
- Tumor oxygenation
 - after carbogen and/or perflubron emulsion administration in tumor xenografts and carbogen administration in patients, 1355-1360
 - rat 9L gliosarcoma and rat 13672 mammary carcinoma, with various doses of a hemoglobin solution, 827-833

U

- Ultrafiltration, isolated, for refractory heart failure in patients with Cooley's anemia, 109-113

V

- $\beta(\text{NA1})\text{Val-deleted}, (\text{NA2})\text{His}^{\sim}\text{Met}$ hemoglobin, synthesized in *Escherichia coli*, functional properties of, 739-745
- Vascular resistance, increased, with hemoglobin-based oxygen carriers, 361-372

- Vasoconstrictive factor
 - acellular and cellular hemoglobin solutions as, 559-564
 - lysophosphatidylcholine as, in quality control of stroma-free hemoglobin, 939-944
- Vasoconstrictor effects, in isolated rabbit heart perfused with bis(3,5-dibromosalicyl) fumarate cross-linked hemoglobin, 565-575

Vesicles

- fluorinated phospholipid based, as potential drug carriers, 1403-1408
- hemoglobin
 - characteristics of and encapsulation procedure for, 861-866
 - stabilized, 467-477
- nonphospholipid, encapsulation of hemoglobin in, 849-854

W

- Whole body rinse-out, with hemoglobin solution, effectiveness of the removal of anti-xeno-antibodies by, 789-794

X

- Xanthine/xanthine oxidase, free radicals generated by, enhanced oxidation of bis(3,5-dibromosalicyl) fumarate α - α cross-linked hemoglobin by, 517-524

Presenting a global view of medical history from paleopathology to molecular biology, here at last is a concise modern text on...

A History of Medicine

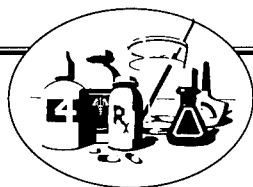

LOIS N. MAGNER
Purdue University, West Lafayette, Indiana

March, 1992
416 pages, illustrated

MARCEL DEKKER, INC.

270 Madison Avenue, New York, NY 10016 ■ (212) 696-9000
Hutgasse 4, Postfach 812, CH-4001 Basel, Switzerland ■ Tel. 061-261-8482

A History of Medicine

On the need for such a text...

From the American Association for the History of Medicine, Inc.'s 1990 Survey Report:

"...our great emphasis on teaching European and American subjects is obtained at the cost of an almost complete neglect of non-Western medical history..."

"...we need a good contemporary text for use in the general introductory survey of the history of Western medicine."

Prepublication praise...

"...a welcome addition to the literature of medical history..."

"...carefully researched and eminently readable....condense[s] thousands of years of medical history into a cohesive and interesting account....I recommend this book with enthusiasm to anyone interested in a general introduction to the history of medicine."

—*John Parascandola, Chief
History of Medicine Division
National Library of Medicine
Bethesda, Maryland (From the Foreword)*

This concise, broadly based text fulfills a need in the literature by providing an up-to-date account of medical history from paleopathology to the most recent theories and practices of modern medicine. It includes not only a wide-ranging overview of Western medicine, but also an introduction to the rich and varied medical traditions of the Near and Far East.



The text stresses the major themes in the history of medicine—placing the modern experience within the framework of historical issues—and it presents medical history as an important part of intellectual and social history, supplying students with a challenging examination of the field that encourages them to question modern medicine's assumptions.

A History of Medicine, the perfect text for a **one-semester** course, is an exemplary synthesis that offers

- a non-technical, jargon-free presentation, making it comprehensible and accessible to a wide audience
- lists of suggested readings that encourage deeper study of particular topics
- striking illustrations that increase reader interest
- a focus on areas that are less familiar to students
- a theme and variations approach that avoids excessive details *and* allows for in-depth discussions of selected subjects
- case histories that represent broader issues and trends

Furnishing both up-to-the-minute scientific concepts and the most recent historical scholarship, ***A History of Medicine*** allows non-science students to learn important points of science painlessly, and helps science students understand the relationship between science and society in a historical context.

Fully indexed to facilitate reference, this is a fine text for all history of medicine courses on both the undergraduate and graduate levels. It is an excellent ancillary text for science teachers who wish to add history to their science courses and for history teachers who wish to include science in their curricula. The lucid and engaging style makes it a highly readable self-study guide for all physicians, biologists, anthropologists, pharmacists, and others in the health related professions, as well as general, medical, science, and pharmaceutical historians, and the informed, sophisticated reader.

A History of Medicine CONTENTS

Paleopathology and Paleomedicine
 Medicine in Ancient Civilizations:
 Mesopotamia and Egypt
 The Great Medical Traditions of
 India and China
 Greco-Roman Medicine
 The Middle Ages
 Islamic Medicine
 Medicine and the Renaissance
 The Scientific Revolution and the
 Circulation of the Blood

Selected Aspects of Clinical and
 Preventive Medicine: From
 Sydenham to Smallpox
 Childbed Fever, Midwifery, and
 Obstetrics
 The Art and Science of Surgery
 The Germ Theory of Disease:
 Medical Microbiology
 Diagnostics and Therapeutics

ISBN: 0-8247-8673-4

This book is printed on acid-free paper.

Mail Today!

ORDER FORM

 For Credit Card and
 Purchase Orders, and Customer Service
CALL TOLL-FREE 1-800-228-1160
 Mon.-Fri., 8:30 a.m. to 5:45 p.m. (EST)
 or FAX your order to 914-796-1772

Mail to: **Promotion Dept., MARCEL DEKKER, INC.**
 270 Madison Avenue, New York, N. Y. 10016

Please send me _____ copy(ies) of **A History of Medicine** by Lois N. Magnier at \$55.00 plus
 \$1.50 for postage and handling per volume. On prepaid orders, add only \$.50 per volume.

I enclose payment in the amount of \$ _____ by:

check money order Visa

MasterCard (4-digit interbank no. _____) Am.Exp.

Card No. _____ Exp. Date _____

Please bill my company: P.O. No. _____

Signature _____
(must be signed for credit card payment)

Name _____

Address _____

City/State/Zip _____

N. Y. residents must add appropriate sales tax. Prices are subject to change without notice.

Marcel Dekker, AG, Basel, bills in U.S. dollars at the United States export price. Payments are accepted in U.S. dollars or in Swiss francs at current day payment conversion rates. Domestic billings in Switzerland are in Swiss francs.

Form No. 039231

Printed in U.S.A.

Understand the relationship between the characteristics of polymers and their applications as biomaterials with...

Polymeric Biomaterials

Contains nearly 840 helpful tables, equations, drawings, and photographs!

edited by **SEVERIAN DUMITRIU**
Polytechnic Institute of Jassy, Romania

October, 1993 / 864 pages, illustrated

Detailing the chemical and physical properties of biomaterials, this **comprehensive** reference investigates the main polymers used in medicine, surgery, and pharmacy such as hydrogels, polysaccharides, elastomers, silicones, polyurethanes, and oligomers—evaluating their biocompatibility, permeability, viscoelasticity, cleavage, bioadhesion, and behavior in the sterilization process.

Considers the role of polymers in solving one of the most pressing medical problems of our time—creating antiviral and anti-cancerous compounds with macro-molecular structures!

Written by **over 40** international experts in the field, ***Polymeric Biomaterials*** describes the use of polymers in

- vascular devices
- skin grafts
- mammary implants
- dental, maxillofacial, and bone surgery
- the replacement of veins and arteries
- absorbable, nonabsorbable, coated, and composite sutures
- delivery systems for the controlled release of drugs
- and much more!

Extensively referenced, providing **more than 2800** literature citations, ***Polymeric Biomaterials*** is an invaluable resource for plastics and biomedical engineers, polymer scientists, biochemists, molecular biologists, macromolecular chemists, pharmacists, cardiovascular and plastic surgeons, and graduate and medical school students in these disciplines.

Marcel Dekker, Inc.

270 Madison Avenue, New York, NY 10016
(212) 696-9000

Hutgasse 4, Postfach 812, CH-4001 Basel, Switzerland
Tel. 061-261-8482

Contents

Polymers as Biomaterials

Polymer Structure and Properties

Severian Dumitriu and Cristina Dumitriu-Medvici

Biocompatibility of Polymers

Severian Dumitriu and Daniela Dumitriu

Heparin and Heparin-like Polysaccharides

Benito Casu

In Vivo Biochemical Significance of Chitin-Based Medical Items

Riccardo Muzzarelli

Modifications to Polymer Surfaces to Improve Blood Compatibility

Rolando Barbucci, Manuela Benvenuti, and Federica Tempesti

Medical and Surgical Applications of Polymers

Polyurethane Elastomers in Medicine

Michael Szycher, Arthur A. Siciliano, and Andrew M. Reed

Innovations and Deviations in Vascular Devices

Edouard Paris, Martin W. King, Robert G. Guidoin, Jean-Marc Delorme, Xiaoyan Deng, and Yvan Douville

Polymers for Dental and Maxillofacial Surgery

Antonio Bascones, José M. Vega, Nieves Olmo, Maria A. Lizarbe, and José G. Gavilanes

Skin Graft Polymers

Alessandro Rastrelli

Sutures: Properties, Uses, and Clinical Investigation

Baruch Guttman and Hilda Guttman

Polymeric Drug and Drug Delivery Systems

Blood-Contacting Polymers

Jacqueline Jozefonvicz and Marcel Jozefowicz

Polymeric Systems for Ophthalmic Drug Delivery

Patricia Fitzgerald and Clive Wilson

Biodegradable Polymers as Drug Carrier Systems

Abraham J. Domb, Shimon Amselem, and Manoj Maniar

Polymeric Drug Carriers

Severian Dumitriu and Maria Dumitriu

Medical Applications of Synthetic Oligomers

Constantin V. Uglea and Cristina Dumitriu-Medvici

Polymeric Micro- and Nanoparticles as Drug Carriers

F. Puisieux, G. Barratt, S. Benita, G. Couarraze, P. Couvreur, J. P. Devissaguet, C. Dubernet, E. Fattal, H. Fessi, and C. Vauthier

Oligomers as "Physical Catalysts" in Biological Processes

Constantin V. Uglea

ISBN: 0-8247-8969-5

This book is printed on acid-free paper.

Also of interest...

Artificial Cells, Blood Substitutes, and Immobilization Technology AN INTERNATIONAL JOURNAL

Editor-in-Chief

THOMAS M. S. CHANG, O.C., M.D., Ph.D., FRCP(C),
Director, Artificial Cells and Organs Research Centre, Professor
of Physiology, Medicine and Biomedical Engineering, Associate
of Chemical Engineering and Chemistry, McGill University,
3655 Drummond Street, Montreal, P.Q., Canada H3G 1Y6

Send for a complimentary copy of this journal today (see coupon...)

1994 Volume 22, 5 Numbers

Artificial Cells, Blood Substitutes, and Immobilization Technology (formerly *Biomaterials, Artificial Cells, and Immobilization Technology*) covers artificial replacement on three structural levels: molecules (biomaterials), cells (artificial cells), and organs (artificial organs).

Subscribe Today!

LIBRARIANS: Make sure the general, transplant, cardiovascular, orthopedic, and other surgeons; physiologists; dentists; biotechnologists; biochemists; pharmacologists; nephrologists; and immunologists that you serve find **Artificial Cells, Blood Substitutes, and Immobilization Technology** on your bookshelves. Order your subscription today either from your subscription agency or directly from Marcel Dekker, Inc.

CALL FOR PAPERS: **Artificial Cells, Blood Substitutes, and Immobilization Technology** welcomes manuscript contributions. Those papers accepted will be published promptly. For complete details regarding manuscript preparation and submission, please contact the Editors directly.

ISSN: 1055-7172

Mail today!

Mail to: Promotion Dept., MARCEL DEKKER, INC.
270 Madison Avenue, New York, N. Y. 10016

- Please send me _____ copy(ies) of **Polymeric Biomaterials** edited by Severian Dumitriu at \$195.00 plus \$1.50 for postage and handling per volume. On prepaid orders add only \$.75 per volume.
- Please enter my subscription to **Artificial Cells, Blood Substitutes, and Immobilization Technology, 1994, Vol. 22, 5 Numbers** at the institutional rate of \$615.00; individual rate of \$307.50 (Individual subscriptions must be paid for by personal check or credit card. Add \$3.50 per number for surface postage outside the U.S. For airmail to Europe, add \$5.50 per number; to Asia, add \$6.50 per number. Orders must be prepaid in U.S. currency.)
- Please send me a complimentary copy of **Artificial Cells, Blood Substitutes, and Immobilization Technology**.

Form No. 099323

Printed in U.S.A.

EDITORIAL BOARD

Associate Editors:

ROBERT S. LANGER, Massachusetts Institute of Technology, Cambridge, MA
ROBERT M. WINSLOW, University of California at San Diego, La Jolla, CA

Assistant Editors:

E. ILAN, T. NISHIYA, and R. SIPEHIA, McGill University, Montreal, Quebec, Canada

Editorial Board

T. AGISHI, Tokyo Women's Medical College, Tokyo, Japan
K. ATSUNMI, University of Tokyo, Tokyo, Japan
R. H. BARLETT, University of Michigan, Ann Arbor, MI
P. E. BARRE, Royal Victoria Hospital, Montreal, Quebec, Canada
V. BONOMINI, St. Orsola University Hospital, Bologna, Italy
G. BRUNNER, Medizinische Hochschule, Hannover, Germany
A. S. CHAWLA, Bureau of Medical Devices, Ottawa, Ontario, Canada
R. C.-J. CHIU, Montreal General Hospital, Montreal, Quebec, Canada
M. M. DEBAKEY, Baylor College of Medicine, Houston, TX
D. FALKENHAGEN, Universitat Rostock, Rostock, Germany
E. FRIEDMAN, Downstate University Medical Center, Brooklyn, NY
J.-L. FUNCK-BRENTANO, Hopital Necker, Paris, France
P. M. GALLETTI, Brown University, Providence, RI
G. GREENBURG, Brown University, Providence, RI
R. GEYER, Harvard University School of Public Health, Boston, MA
G. GREGORIADIS, University of London, London, England
J. GRUNWALD, The Israel Institute for Biological Research, Ness-Ziona, Israel
R. G. GUIDON, Laval University, Quebec City, Quebec, Canada
H. J. GURLAND, Ludwig-Maximilians-Universität München, München, Germany
B. L. HE, Nankai University, Nankai, People's Republic of China
J. HELLER, Stanford Research Institute, Menlo Park, CA
A. S. HOFFMAN, University of Washington, Seattle, WA
M. HORI, University of Tsukuba, Tsukuba Ideapolis, Japan
Y. KALAL, Czechoslovak Academy of Sciences, Prague
A. KANTROWITZ, Sinai Hospital of Detroit, Detroit, MI

M. KAYE, Montreal General Hospital, Montreal, Quebec
H. KLUNKMAN, Universitat Rostock, Rostock, Germany
W. J. KOLFF, College of Medicine, Salt Lake City, UT
T. KONDO, Science University of Tokyo, Tokyo, Japan
R. S. LANGER, Massachusetts Institute of Technology, Cambridge, MA
P. S. MALCHESKY, Cleveland Clinic Foundation, Cleveland, OH
G. MOSS, Michael Reese Hospital, Chicago, IL
V. NICOLAEV, Academy of Sciences of the Ukrainian SSR, Ukraine
V. NOSE, Cleveland Clinic, Cleveland, OH
M. ODAKA, Chiba University School of Medicine, Inohana, Chiba, Japan
D. G. OREOPOULOS, Toronto Western Hospital, Toronto, Ontario
K. OTA, Tokyo Women's Medical College, Tokyo, Japan
E. PISKIN, Hacettepe University, Ankara, Turkey
M. POZNANSKY, University of Alberta, Edmonton, Alberta
G. REACH, INSERM, Paris, France
S. M. G. RINGOIR, University of Ghent, Ghent, Belgium
S. SAHA, Louisiana State University, Shreveport, LA
G. E. SCHREINER, Georgetown University School of Medicine, Washington, D.C.
M. V. SEFTON, University of Toronto, Toronto, Ontario, Canada
S. SEKIGUCHI, Hokkaido Red Cross Blood Center, Sapporo, Japan
J. F. SHACKELFORD, University of California, Davis, CA
C. P. SHARMA, Institute for Medical Sciences & Technology, India
S. SIDEMAN, Technion—Israel Institute of Technology, Technion City, Haifa, Israel
P. SOON-SHONG, Islet Transplant Institute, Los Angeles, CA
G. SPLENDIANI, University of Rome-Columbus, Rome, Italy
A. M. SUN, Connaught Research Institute, Willowdale, Ontario, Canada
A. TREVINO-BECERRA, Co. Veronica Anzures, Mexico
R. VALERI, Boston University, Boston, MA
H. WEETALL, CIBA-Corning Diagnostics, Merfield, MA
R. WILLIAMS, King's College Hospital, London, England
J. F. WINCHESTER, Georgetown University Hospital, Washington, D.C.
L. B. WINGARD, University of Pittsburgh, Pittsburgh, PA
R. WINSLOW, Letterman Army Institute of Research, San Francisco, CA
Y.-T. YU, Nankai University, Nankai, People's Republic of China

ORDER FORM

I enclose payment in the amount of \$ _____ by:

check money order Visa

MasterCard (4-digit interbank no. _____) Am. Exp.

Card No. _____ Exp. Date _____

Please bill my company: P.O. No. _____

Signature _____
(must be signed for credit card payment)

Name _____

Address _____

City/State/Zip _____

U.S. residents must add appropriate sales tax. Canadian customers add 7% GST. Prices are subject to change without notice.

For Credit Card and Purchase Orders, and Customer Service
CALL TOLL-FREE 1-800-228-1160
 Mon-Fri, 8:30 a.m. to 5:45 p.m. (EST)
 or FAX your order to 914-796-1772

Increase your awareness of the long-term clinical and scientific problems of...

Organ Transplantation

LONG-TERM RESULTS

edited by

LEENDERT C. PAUL

*The University of Calgary and Foothills Provincial General Hospital,
Calgary, Alberta, Canada*

KIM SOLEZ

University of Alberta, Edmonton, Alberta, Canada

July, 1992

432 pages, illustrated

\$145.00

This unique monograph focuses on the long-term results and complications of organ transplant procedures—presenting an overview of **nearly all types** of vascularized organs and providing insights into **recent advances** in research and clinical practice.

Written by over 35 experts from around the world, **Organ Transplantation**...

- describes the underlying immunological mechanisms for long-term acceptance of foreign grafts and the mechanisms of chronic rejection
- discusses tissue typing for the long-term survival of kidney transplant recipients as well as the most common long-term causes of morbidity and mortality
- covers the long-term benefits and risks of cyclosporine therapy, recurrent immune mediated diseases in the kidney, and the high incidence of atherosclerosis, hypertension, infections, tumors, skin changes, and liver problems
- explores the prevalence, clinical manifestations, and histopathology of chronic rejection of the heart, lung, liver, kidney, and pancreas
- details potential dietary and pharmacologic interventions to prevent or treat graft damage
- and more!

Generously referenced with more than 1000 literature citations, **Organ Transplantation** is an invaluable tool for transplant surgeons, nephrologists, cardiologists and cardiovascular surgeons, immunologists, pathologists, hepatologists, endocrinologists, pulmonologists, oncologists, urologists, internists, infectious disease specialists, pharmacologists, and medical and surgical residents.

CONTENTS

Immunological Mechanisms of Long-Term Graft Acceptance, <i>Ian V. Hutchinson</i>	Long-Term Outcome of Pancreas Transplants Functioning at One Year, <i>David E. R. Sutherland, Kay Moudry-Munns, Kristin Gillingham, and Raouf Nakhleh</i>
Long-Term Results of Kidney Transplantation in Eurotransplant, <i>Jane Thorogood, Hans C. van Houwelingen, Jan J. van Rood, Frans A. Zantvoort, Geziema M. Th. Schreuder, and Guido G. Persijn</i>	Heart-Lung Transplantation and Lung Transplantation: The Challenge of Obstructive Bronchiolitis, <i>Tim Higenbottam and Colin Clelland</i>
Long-Term Mortality, Morbidity, and Rehabilitation in Organ Transplant Recipients, <i>Paul A. Keown, Christopher R. Shackleton, and Beryl M. Ferguson</i>	Glomerular Diseases in Renal Transplants, <i>Harry J. Ward and Richard J. Glassock</i>
Long-Term Benefits and Risks of Cyclosporine Therapy, <i>John Dunn and Barry D. Kahan</i>	Atherosclerosis in Organ Transplant Recipients, <i>Bertram L. Kasiske</i>
Chronic Rejection of Vascularized Organ Allografts, <i>Leendert C. Paul and Kim Solez</i>	Hypertension in Organ Transplant Recipients, <i>Ralph G. Hawkins and Ellen D. Burgess</i>
Pharmacological Intervention of Chronic Graft Rejection, <i>Bengt Fellström</i>	Malignancies after Organ Transplantation, <i>Douglas W. Hanto, Mark W. Shelton, and Richard L. Simmons</i>
Chronic Renal Graft Rejection, <i>M. C. Foster and M. J. S. Dennis</i>	Skin Changes in Organ Transplant Recipients, <i>A. G. R. Steil</i>
Cardiac Graft Arteriosclerosis, <i>Donald V. Cramer</i>	Liver Problems in Renal Transplant Patients, <i>Patrick S. Parfrey and Ronald D. Guttman</i>
Chronic Heart Graft Rejection in the Clinical Setting, <i>A. H. M. M. Balk and W. Weimar</i>	Are Dietary Interventions Justified for Recipients of Organ Transplants?, <i>P. Magner, J. Homan van der Heide, and Leendert C. Paul</i>
Chronic Hepatic Allograft Rejection: A Review of Ductopenic Rejection and the Vanishing Bile Duct Syndrome, <i>Russell H. Wiesner, Jürgen Ludwig, Bart van Hoek, and Ruud A. F. Krom</i>	

ISBN: 0-8247-8599-1

This book is printed on acid-free paper.

Marcel Dekker, Inc.

270 Madison Avenue, New York, NY 10016 ■ (212) 696-9000

Hutgasse 4, Postfach 812, CH-4001 Basel, Switzerland ■ Tel. 061-261-8482

**INSTRUCTIONS FOR PREPARATION OF MANUSCRIPTS
FOR DIRECT REPRODUCTION IN**

**ARTIFICIAL CELLS, BLOOD SUBSTITUTES,
AND IMMOBILIZATION BIOTECHNOLOGY
AN INTERNATIONAL JOURNAL**

(REVISED, 1994)

MANUSCRIPTS

The journal will consider the publication of materials related to the aims and scopes described earlier. Manuscripts can be in the following forms:

1. Editorial (invited)
2. Critical Reviews
3. Original Research Papers
4. Techniques and Methods
5. Case Histories
6. Rapid Preliminary Communications
7. Letters to the Editor
8. New Books
9. Announcements

**DIRECTIONS FOR SUBMISSION TO ARTIFICIAL CELLS,
BLOOD SUBSTITUTES, AND IMMOBILIZATION BIOTECHNOLOGY**

1. Please submit one original and two copies, placed between heavy cardboard. Also include a diskette, preferably DOS WordPerfect.
2. Submit manuscripts to Professor T. M. S. Chang, Director, Artificial Cells and Organs Research Centre, McGill University, 3655 Drummond Street, Montreal, Quebec, Canada, H3G 1Y6, by first class mail. Manuscripts can also be submitted to any of the Associate Editors.
3. Acceptance of contributed articles is based on peer reviews.

INSTRUCTIONS FOR PREPARATION OF MANUSCRIPTS

All contributions are reproduced by directly photographing. It will appear in the journal exactly as you have submitted it. It is therefore important to follow the following instructions.

TYPING INSTRUCTIONS

1. Please type with 1 line spacing (do not use double spacing) on good quality white bond paper (21.6 x 27.9 cm).

2. The typing area of the first page, including the title, should be no more than 14 x 18 cm. The typing area of all other pages should be no more than 14 x 21.6 cm.

3. Please use laser printer and Roman fonts. If using other types of printers, please use letter quality prints. Elite-spacing typeface (12 characters per horizontal inch) is preferred.

FORMAT OF MANUSCRIPTS

1. Title

It should be in capital letters and centered. It should be 5 cm from the top of the page. This is followed by a one-line space and then by the name(s) and address(es) of the author(s), in the following way:

RESEARCH ON ARTIFICIAL CELLS, BLOOD SUBSTITUTES, AND
IMMOBILIZATION BIOTECHNOLOGY

John Smith, M.D., Ph.D.
Department of Biotechnology
Faculty of Medicine
State University
City, State, Country, Area Code

Author can include professional degrees. However, this is completely optional.

2. Abstracts

Abstracts should start after a two-line space below the title. Maximum length is 200 words.

3. Article

- a. Subdivide article into Introduction, Materials and Methods, Results, Discussion, Acknowledgements, and References. These first level headings should be centered and all capitalized.
- b. Second level headings should be flush with the left margin, bold face or underlined.
- c. Use a blue pencil to number each page at the bottom.

TABLES

Tables should be printed as part of the text at the exact site where it is to appear. Table should not run over to the next page. Start each table by TABLE and the number (Roman). This is followed by the table title.

DRAWINGS, GRAPHS, AND OTHER FIGURES

These should be laser printed or professionally drawn in black India ink. Each figure, drawing, or graph should be lightly taped to a separate sheet of white or

drawing paper, and placed as a group at the end of the article. The figure numbers, name of senior author, and arrow indicating "top" should be written in light blue pencil on the back, or should be typed on a gummed label attached to the back of the illustration. Photographs should be glossy prints. A laser printer, typewriter, or lettering set should be used for all labels; they may not be hand drawn. Captions for figures should be typed single-spaced along the full width of the type page and preceded by the word FIGURE and a number in Arabic numerals. All figure legends should be typed on a single page, which is to be placed at the end of the article, directly following the group of figures. Mark the text of the article lightly in light blue pencil where figures or photos are to appear.

REFERENCES

These should be typed single-spaced with one space between each reference. They should be referred to in the text and numbered consecutively in brackets. The full references should contain: Author's name, with surname first, title of the paper (optional), name of the journal (Chemical Abstracts Abbreviations), volume, first and last pages (last page optional), and year (in parentheses).

NOTES

1. All typographical or technical errors missed by the reviewer will appear in print.
2. Manuscripts are accepted with the understanding that the authors have obtained written permission to reproduce published material.
3. When full-color illustrations are accepted, the full cost is assumed by the author or his sponsor.
4. Artwork will be disposed of three months after publication.
5. The author or advertiser is solely responsible for all data, opinions, and statements appearing in his/her article(s). The editor-in-chief, associate editors, assistant editors, editorial board, and the publisher are not responsible or liable for the author's data, opinions, statements, or other matters in the author's article.
6. Submitted manuscripts should not be under simultaneous consideration elsewhere.
7. All information should appear in the main text. Do not use addenda and appendices.
8. Accepted manuscripts become the property of the journal and may not be published elsewhere without written permission from both the author and the publisher.

9. Rejected manuscripts are returned to the author. The journal is not responsible in the event any manuscript is lost.

REPRINTS

Reprints are available in quantities of 100 and multiples thereof. For orders of 100 or more reprints, twenty (20) free copies are provided. A reprint order form and price list will be sent to the author with notification of acceptance of the manuscript.