

REPORT DOCUMENTATION PAGE			Form Approved OMB No. 0704-0188	
Public reporting burden for this collection of information is estimated to average 1 hour per response, including the time for reviewing instructions, searching existing data sources, gathering and maintaining the data needed, and completing and reviewing the collection of information. Send comments regarding this burden estimate only, other aspect of this collection of information, including suggestions for reducing this burden, to Washington Headquarters Services, Directorate for Information Operations and Reports, 1215 Jefferson Davis Highway, Suite 1204, Arlington, VA 22202-4302, and to the Office of Management and Budget, Paperwork Reduction Project (07804-0188), Washington, DC 20503.				
1. AGENCY USE ONLY (LEAVE BLANK)		2. REPORT DATE 12 April 1995		3. REPORT TYPE AND DATES COVERED Professional Paper
4. TITLE AND SUBTITLE AGM-154 Joint Standoff Weapon			5. FUNDING NUMBERS	
6. AUTHOR(S) LT Dan Hinson, USN, Mike Griffith				
7. PERFORMING ORGANIZATION NAME(S) AND ADDRESS(ES) DEPARTMENT OF THE NAVY NAVAL AIR WARFARE CENTER AIRCRAFT DIVISION PATUXENT RIVER, MARYLAND 20670-5304			8. PERFORMING ORGANIZATION REPORT NUMBER	
9. SPONSORING/MONITORING AGENCY NAME(S) AND ADDRESS(ES)			10. SPONSORING/MONITORING AGENCY REPORT NUMBER	
11. SUPPLEMENTARY NOTES				
12a. DISTRIBUTION/AVAILABILITY STATEMENT APPROVED FOR PUBLIC RELEASE; DISTRIBUTION IS UNLIMITED.			12b. DISTRIBUTION CODE	
13. ABSTRACT (Maximum 200 words) See the attached paper for detailed information.				
14. SUBJECT TERMS Joint Standoff Weapon, Integrated Test Team,F/A-18			15. NUMBER OF PAGES 20	
			16. PRICE CODE	
17. SECURITY CLASSIFICATION OF REPORT UNCLASSIFIED	18. SECURITY CLASSIFICATION OF THIS PAGE UNCLASSIFIED	19. SECURITY CLASSIFICATION OF ABSTRACT UNCLASSIFIED	20. LIMITATION OF ABSTRACT UL	

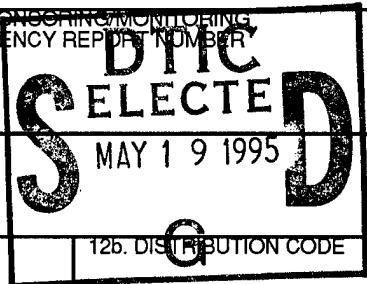

Accession For	
NTIS CRA&I	<input checked="" type="checkbox"/>
DTIC TAB	<input type="checkbox"/>
Unannounced	<input type="checkbox"/>
Justification	
By	
Distribution /	
Availability Codes	
Dist	Avail and/or Special
A-1	

19950518 034

DTIC QUALITY INSPECTED 5

Hello, I'm LT Dan Hinson and this is Mike Griffith. We are the JSOW Project Officer and Lead Engineer at Pax River. We came here today to give you a quick overview of what the JSOW is and describe the testing completed to date.

JSOW stands for 'Joint Standoff Weapon'. It was designed to be an affordable air-delivered stand-off weapon that is capable against fixed, relocatable and moving targets. It can be used during day, night, and in or through adverse weather. It is designed for low or high altitude launch capability from outside target point defenses. The JSOW will maximize interoperability and affordability through system commonality with USMC and USAF platforms. All variants of the JSOW will be all-up rounds (AUR), using common equipment when possible. The JSOW is a launch and leave type weapon that will allow for multiple kills during a single attack. The JSOW can be supported by current and future mission planning assets. The JSOW specifications require that it can be carried throughout full subsonic aircraft envelopes and supersonic dash capability on the F/A-18 with minimum restrictions. [REDACTED] the following launch envelope; Mach Number 0.60 to 0.95, +10 to -45 degrees pitch, 15 degrees roll and release altitudes from 200 ft AGL to 30,000 ft MSL. The JSOW must meet the Navy Insensitive Munitions, HERO, and Environmental Safety Criteria. The gross weight of the JSOW baseline variant was limited to 1,065 lbs. to be compatible with the AV-8B. The

SECURITY

APR 12 1995

Glenn A. Shindler

18 APR 1995

following overhead (slide #6) shows the three JSOW variants. The next overhead (slide #7) shows the breakout of the JSOW components.

JSOW developmental flight testing consisted of Air Worthiness Testing (Flutter, Active Oscillation Control (AOC), Handling Qualities, Loads, Adjacent Store Eject (G-Jump), Noise and Vibrations, and Carrier Suitability), Developmental Testing Phase IIA (safe separation for jettison and launch envelopes), and Developmental Testing Phase IIB (weapon system performance to target). The JSOW Integrated

PRODUCT [Test] Team (IPT) (ITT) is responsible for getting JSOW to the fleet.

AN INTEGRATED TEST TEAM (ITT) WAS ESTABLISHED TO CONDUCT THE TEST PROGRAM.

This includes the Navy (NAVAIR, NAWCAD and NAWCWPNS), Texas Instruments, and McDonnell Douglas Aerospace. The biggest program issue faced by the ITT was to complete a wide and diverse series of tests on a limited budget and number of assets. The ITT has been working through those issues by maintaining close coordination throughout the program, maximizing use of pre-flight and post-flight data reduction techniques, and combining multiple objectives on each flight possible. Coordination with OPEVAL personnel has been an ongoing effort to reduce risks during that phase of testing. Seventy flights totaling 94.9 flight hours were flown during Air Worthiness testing. The pre-test breakdown is as follows; Flutter (12/13.8), AOC (6/6.8), FQ&P (7/13.3), Loads (18/6.1), CVS (13/13.1), Noise and Vibration (14/13.8). No restrictions were imposed with

wingtip missiles on. With wingtip missiles off, the F/A-18 will be limited to 575 KCAS when below 15,000 ft MSL and four JSOW are being carried. Seventeen flights totalling 11.2 flight hours have been flown to demonstrate the jettison and launch envelopes. All jettison testing was conducted at Pax River. All safe separation launch testing has been and will continue to be conducted at NAWCWPNS range by Pax River personnel. Jettison testing has been conducted to 575 KCAS, 0.95 IMN in a 45 degree dive. Inboard testing has been completed to 575 KCAS, 0.95 IMN in a level delivery. All launch testing has been conducted on the outboard station.

ACCURACY

DT-IIB testing is being conducted by NAWCWPNS China Lake, with NAWCAD Pax River cooperation where required to accomplish launch envelope requirements while conserving test assets. This testing will demonstrate capability to deliver payload on target with the F/A-18C/D. Each evaluation will have multiple objectives including transfer alignment, payload delivery and dispersion accuracy, AUR flight range, flight performance and navigation, and sub-system kinematics performance. Ten launches are planned. The first was conducted on 13 December, 1994.

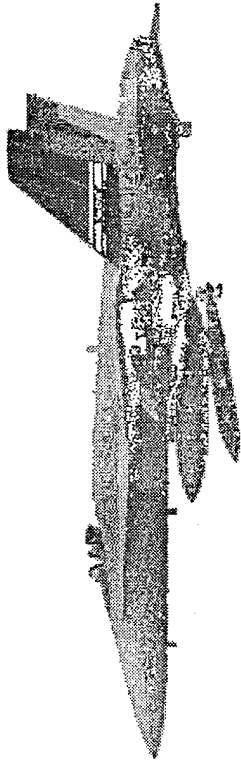

**AGM-154
Joint Standoff Weapon
(JSOW)**

**Mike Griffith, 4.11.2.4 MG
JSOW Project Engineer**

**LT Dan Hinson, USN
JSOW Project Officer**

**Naval Air Warfare Center, Aircraft Division
Air Vehicle/Store Compatibility Division
21884 Nickles Road
Patuxent River, MD 20670
Phone: (301) 826-4171, DSN 326-4171**

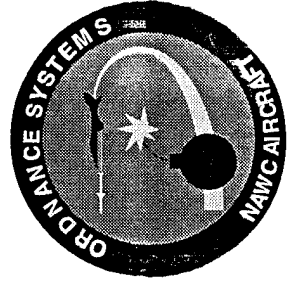

Presentation Overview

- Introduction
- The Joint Standoff Weapon (JSOW)
- JSOW Developmental Flight Testing
- Integrated Test Team
- Air Worthiness Testing (AWT)
- Developmental Test phase IIA (DT-IIA)
- Developmental Test phase IIB (DT-IIB)
- Conclusions and Questions



JSOW Operational Requirement

- Affordable air-delivered stand-off weapon.
- Capable against fixed, relocatable and moving targets.
- Usable day, night, and in or through adverse weather.
- Low or high altitude launch capability from outside target point defenses.
- Maximize interoperability and affordability through system commonality with USMC and USAF platforms.
- All variants shall be all-up rounds (AUR), using common equipment when possible.

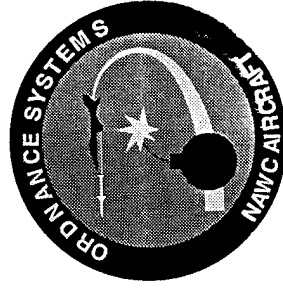
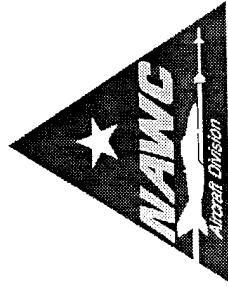

JSOW Capabilities

- Launch and Leave
- High effectiveness against a wide spectrum of targets.
- Low cost.
- Large Inventory.
- Day, night, and adverse weather capability.
- Multiple kills/single attack.

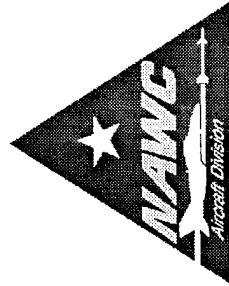
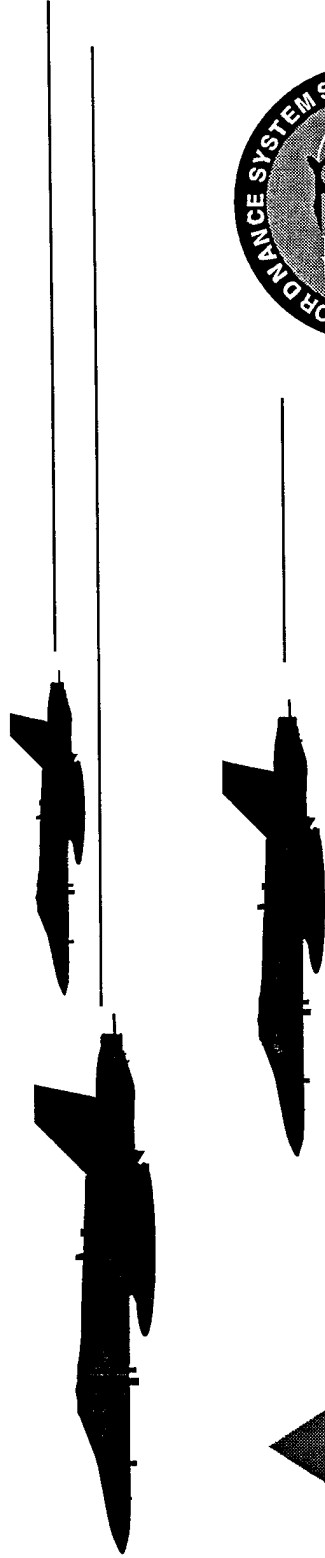

System Specifications (Partial List)

- Supported by current/future Mission Planning Assets.
- Carriage throughout full subsonic aircraft envelopes and supersonic dash capability on the F/A-18.
- Launch Envelope:
 - Mach Number 0.60 to 0.95
 - +10 to -45 degrees pitch, 15 degrees roll
 - 200 ft AGL to 30,000 ft MSL
- Weapon must meet the Navy Insensitive Munitions, HERO, and Environmental Safety Criteria.
- Gross Weight limited to 1065 lbs (AV-8B limit).

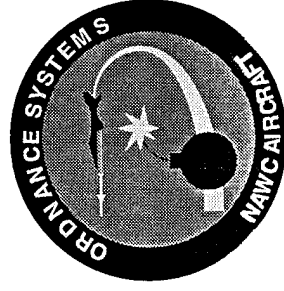

JSOW Configurations

Baseline

- Signature Management
- Kinematically Efficient Airframe

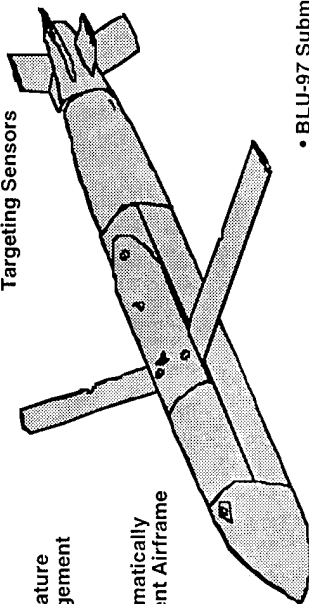

- Aircraft/3rd Party Targeting Sensors

- BLU-97 Submunitions

Unitary

- Data Link
 - Aim Point Selection
 - BDA/IFF
 - Moving Target

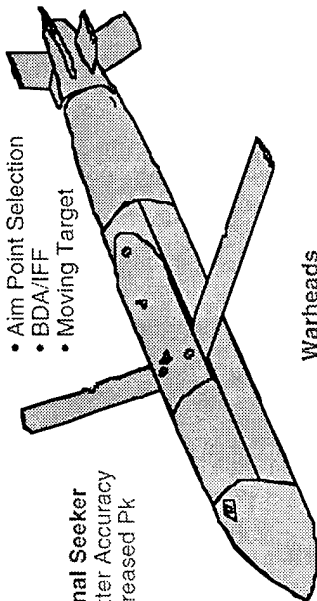

- Terminal Seeker
 - Better Accuracy
 - Increased Pk

- Warheads
 - Unitary
 - Greater Target Set

JSOW / BLU-108

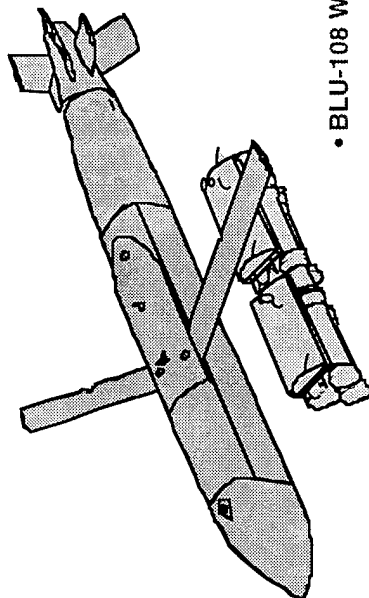

- BLU-108 Warhead



JSOW Common Components

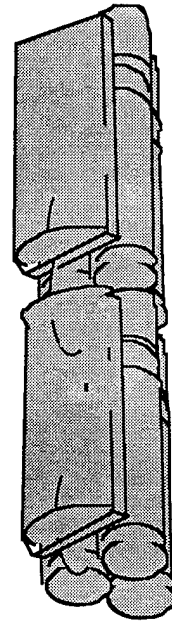
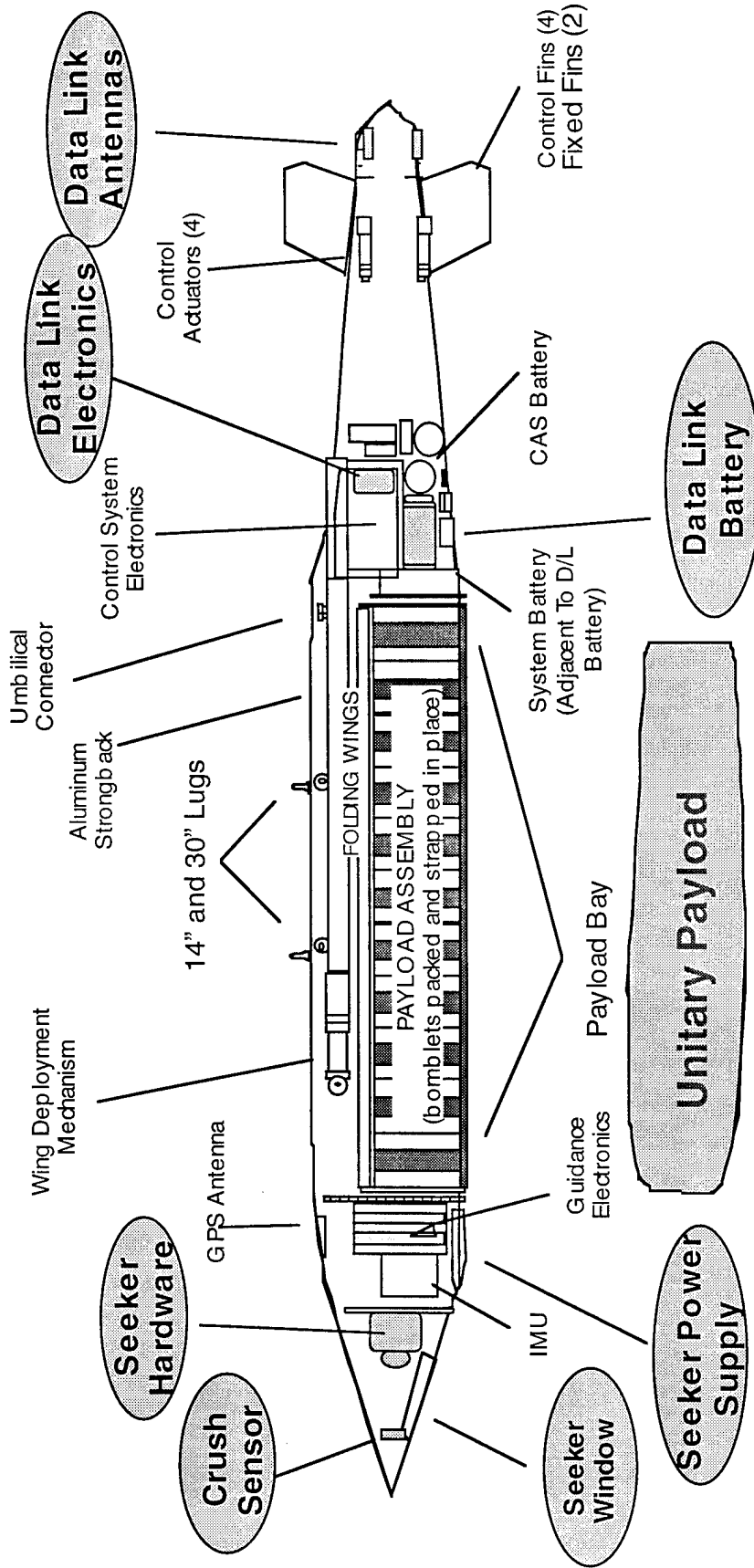

6 BLU-108 with 24 total Skeet



JSOW Developmental Flight Testing

- **Air Worthiness Testing (AWT):**
 - Flutter
 - Active Oscillation Control (AOC)
 - Handling Qualities
 - Loads
 - Adjacent Store Eject (G-jump)
 - Noise and Vibrations
 - Carrier Suitability
- **Developmental Testing phase IIA:**
 - Safe Separation for Jettison and Launch Envelopes
- **Developmental Testing phase IIB**
 - Weapon System Performance to Target

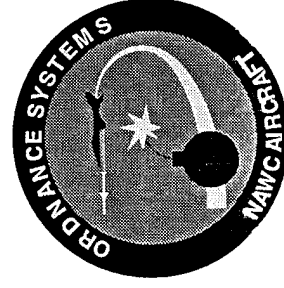
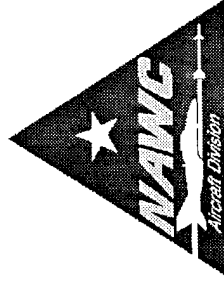
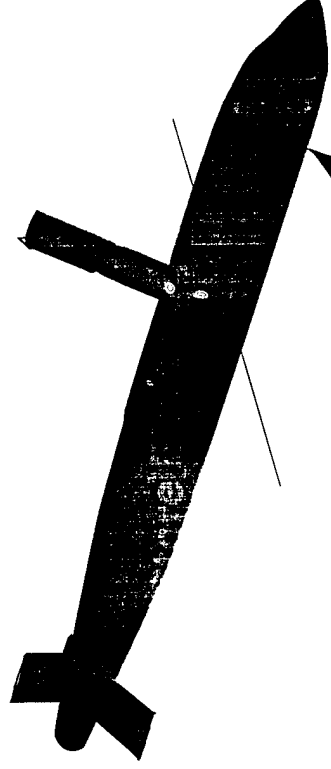

Integrated Test Team

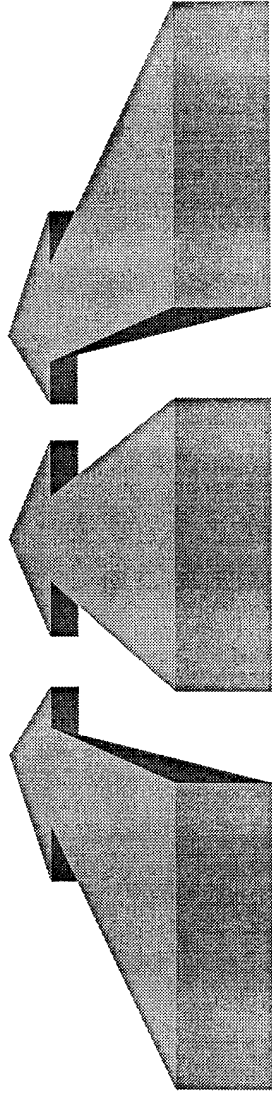

- Texas Instruments
- Navy
 - NAVAIR
 - NAWCAD
 - NAWCWPNS
- McDonnell Douglas Aerospace

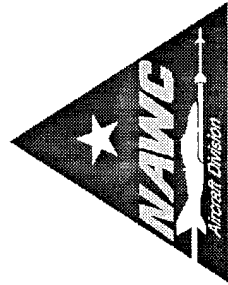

Integrated Test Team



- **Program Issues**
 - Limited Budget and Assets
 - Wide and Diverse Series of Test
- **Resolutions through the ITT**
 - Close coordination early on (T&E meetings, QPR's).
 - Preflight/Postflight data correlation with team review.
 - Maximize DT-IIA & DT-IIB objectives from each flight.
 - OPEVAL coordination early on.



Air Worthiness Testing

<u>Test</u>	<u>Lead</u>	<u>Support</u>	<u>Flights</u>	<u>Hours</u>
Flutter	MDA	Navy/TI	12	13.8
AOC	MDA	Navy/TI	6	6.8
FQ & P	Navy	MDA/TI	7	13.3
Loads	MDA	Navy	18	6.1
CVS	Navy	MDA/TI	13	31.1
<u>Noise/Vibs</u>	<u>Navy</u>	<u>MDA/TI</u>	<u>14</u>	<u>13.8</u>
Total			70	94.9

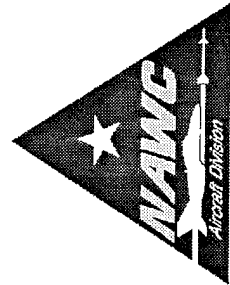

AWT Test Results

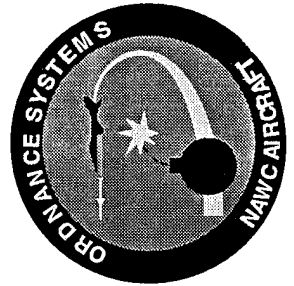
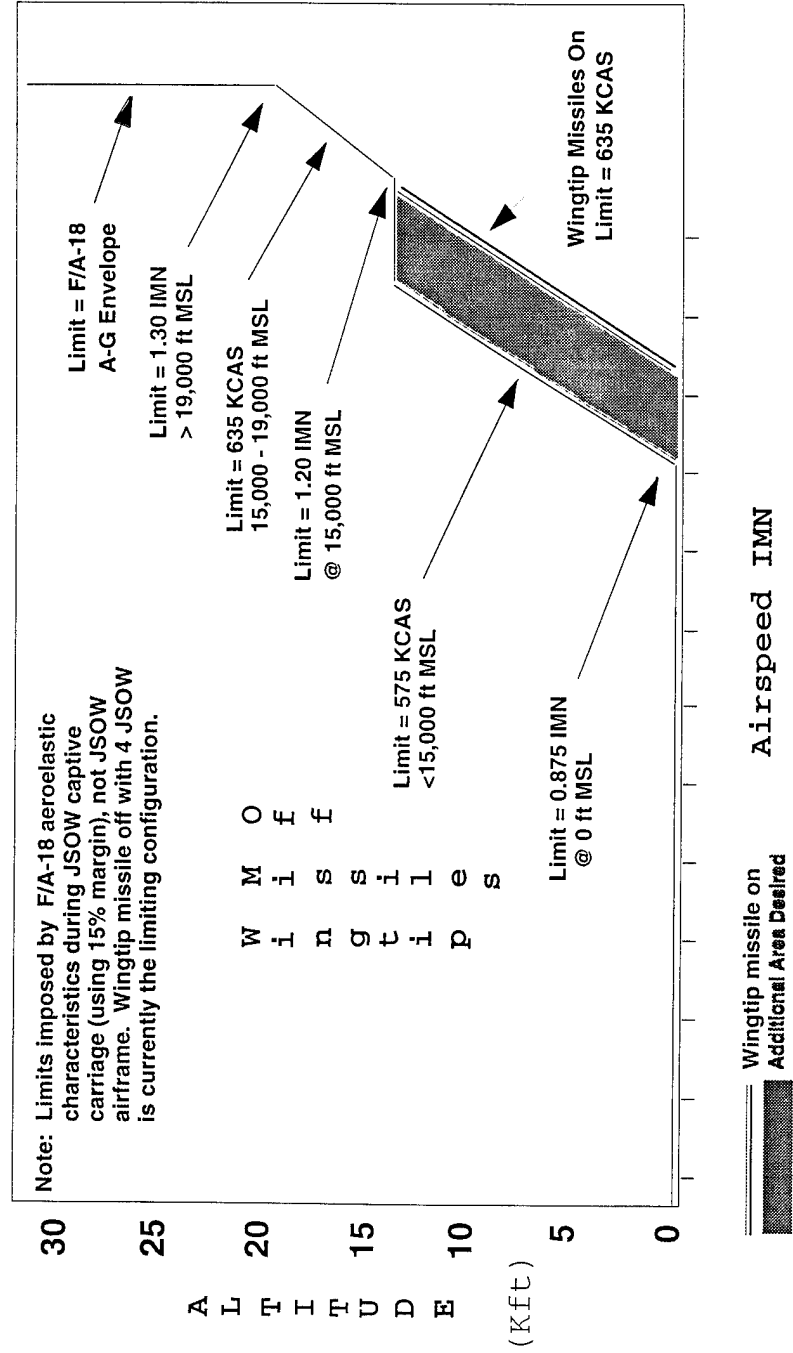

DT-IIA Testing

<u>Test</u>	<u>Lead</u>	<u>Support</u>	<u>Flights</u>	<u>Hours</u>
Fit & Function	Navy	MDA/TI	N/A	24.0
Ground Eject	Navy	MDA/TI	N/A	24.0
Jettison	Navy	MDA/TI	15	8.6
<u>Launch</u>	<u>Navy</u>	<u>MDA/TI</u>	<u>1</u>	<u>1.3</u>
Total (to date)			16	9.9

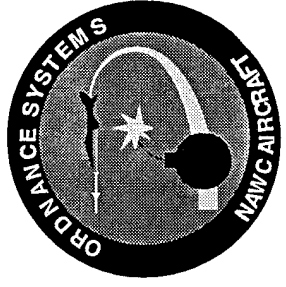

First JSOW Launch



PMA-201

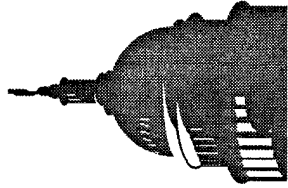

Washington
D.C.

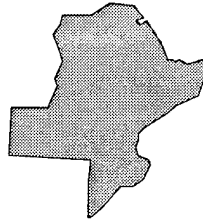
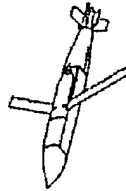
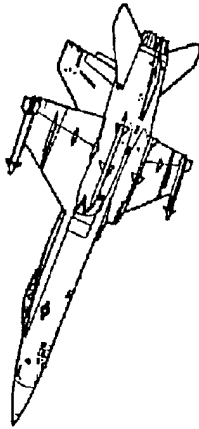

T.I.

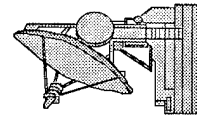

RCC

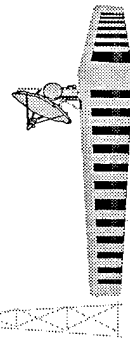

T-Pad

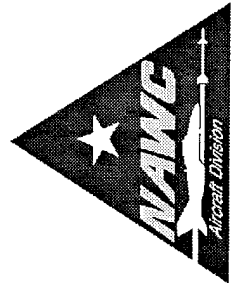

DT-IIA Test Results

JETTISON:

Outboard- 575 KCAS / 0.95 IMN / 45 degree dive

Inboard- 575 KCAS / 0.95 IMN / Level

LAUNCH:

Outboard- 500 KCAS / 0.82 IMN / Level

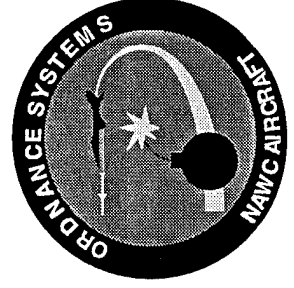
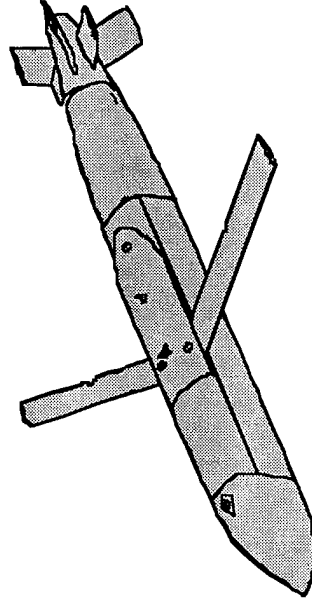

DT-IIB Testing

- To be conducted by NAWCWPNS China Lake, with NAWCAD Pax River cooperation where required to accomplish launch envelope requirements while conserving test assets.
- Must demonstrate capability to deliver payload on target with the F/A-18C/D.
- Each evaluation will have multiple objectives, including transfer alignment, payload delivery and dispersion accuracy, AUR flight range, flight performance and navigation, and sub-system kinematic performance.
- 10-shot matrix. First launch 13 Dec 94; next 16 Feb 95.

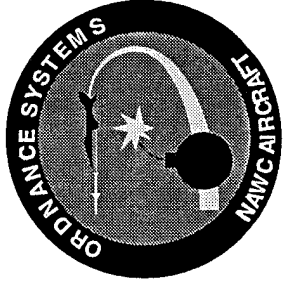

Conclusions

- **Air Worthiness testing complete.**
 - Full A/G envelope with wingtip missiles on.
 - F/A-18 AOC flight control mode not required.
 - Flight restriction below 15,000 ft without wingtip missiles.
- **Jettison separation testing complete.**
 - Outboard cleared to full envelope with adjacent tank ~~(and in-dive)~~ *delete*
 - Inboard cleared to full envelope with outboard stores.
- **Successful first launch on 13 December 1994.**
- **Integrated Test Team success story.**
- **Schedule for tomorrow.**
- **Questions?**

