

METRIC

MIL-STD-461D
11 JANUARY 1993

SUPERSEDING
MIL-STD-461C
4 AUGUST 1986

MILITARY STANDARD

REQUIREMENTS FOR THE CONTROL OF ELECTROMAGNETIC INTERFERENCE EMISSIONS AND SUSCEPTIBILITY



DTIC QUALITY INSPECTED 5

19950518 019

AMSC N6852

AREA EMCS

DISTRIBUTION STATEMENT A. Approved for public release; distribution is unlimited.

DISCLAIMER NOTICE

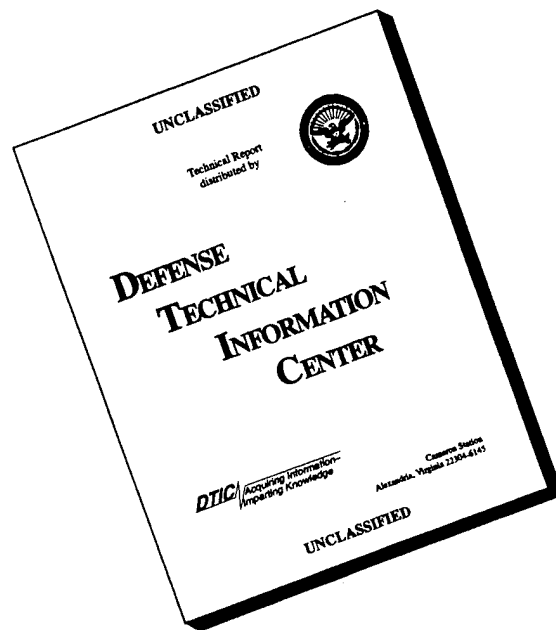

THIS DOCUMENT IS BEST QUALITY AVAILABLE. THE COPY FURNISHED TO DTIC CONTAINED A SIGNIFICANT NUMBER OF PAGES WHICH DO NOT REPRODUCE LEGIBLY.

MIL-STD-461D

FOREWORD

1. This military standard is approved for use by all Departments and Agencies of the Department of Defense.
2. Beneficial comments (recommendations, additions, deletions) and any pertinent data which may be of use in improving this document should be addressed to: Commander, Space and Naval Warfare Systems Command, Attn: SPAWAR 2243, Washington, DC, 20363-5100, by using the self-addressed Standardization Document Improvement Proposal (DD Form 1426) appearing at the end of this document or by letter.
3. The stated requirements represent the minimum considered necessary to provide reasonable confidence that a particular subsystem or equipment complying with these requirements will function within their designated design tolerances when operating in their intended electromagnetic environment. Test methods to be used to demonstrate compliance to this document are contained in MIL-STD-462.
4. Substantial changes have been made from previous editions. Some requirements have been eliminated, others significantly changed, and new requirements added. An appendix has been introduced which provides the rationale and background for each paragraph.
5. The requirements contained in this document may be tailored by the procuring activity for each application and intended operational Electromagnetic Environment (EME).
6. A joint committee consisting of representatives of the Army, Air Force, Navy, and Industry prepared this document.

Accession For	
NTIS GRA&I	<input checked="" type="checkbox"/>
DTIC TAB	<input type="checkbox"/>
Unannounced	<input type="checkbox"/>
Justification	
By	
Distribution/	
Availability Codes	
Dist	Avail and/or Special
A-1	

MIL-STD-461D

CONTENTS

<u>PARAGRAPH</u>		<u>PAGE</u>
1	SCOPE	1
1.1	Purpose	1
1.2	Application	1
1.2.1	General applicability	1
1.2.2	Tailoring of requirements	1
1.3	Emission and susceptibility designations	1
2	APPLICABLE DOCUMENTS	2
2.1	Government documents	2
2.1.1	Specifications, standards, and handbooks	2
2.1.2	Other Government documents, drawings, and publications	2
2.2	Non-Government publications	3
2.3	Order of precedence	3
3	DEFINITIONS	4
3.1	General	4
3.2	Acronyms used in this standard	4
3.3	Above deck	4
3.4	Below deck	4
3.5	External installation	4
3.6	Flight-line equipment	4
3.7	Internal installation	5
3.8	Metric units	5
3.9	Non-developmental item	5
3.10	Safety critical	5
4	GENERAL REQUIREMENTS	6
4.1	General	6
4.2	Joint procurement	6
4.3	Filtering (Navy only)	6
4.4	Self-compatibility	6
4.5	Non-Developmental Items (NDI)	6
4.5.1	Commercial off-the-shelf equipment	6
4.5.1.1	Selected by contractor	6
4.5.1.2	Specified by procuring activity	7
4.5.2	Procurement of equipment or subsystems having met other EMI requirements	7
4.6	Government Furnished Equipment (GFE)	7
4.7	Testing requirements	7
4.8	Switching transients	7
5	DETAILED REQUIREMENTS	8
5.1	General	8
5.1.1	Units of frequency domain measurements	10

MIL-STD-461D

CONTENTS

<u>PARAGRAPH</u>		<u>PAGE</u>
5.2	EMI control requirements versus intended installations	10
5.3	Emission and susceptibility requirements and limits	11
5.3.1	CE101 (Conducted emissions, power leads, 30 Hz to 10 kHz)	11
5.3.1.1	CE101 applicability	11
5.3.1.2	CE101 limits	11
5.3.2	CE102 (Conducted emissions, power leads, 10 kHz to 10 MHz)	11
5.3.2.1	CE102 applicability	11
5.3.2.2	CE102 limits	11
5.3.3	CE106 (Conducted emissions, antenna terminal, 10 kHz to 40 GHz)	11
5.3.3.1	CE106 applicability	11
5.3.3.2	CE106 limits	12
5.3.4	CS101 (Conducted susceptibility, power leads, 30 Hz to 50 kHz)	12
5.3.4.1	CS101 applicability	12
5.3.4.2	CS101 limit	12
5.3.5	CS103 (Conducted susceptibility, antenna port, intermodulation, 15 kHz to 10 GHz)	13
5.3.5.1	CS103 applicability	13
5.3.5.2	CS103 limit	13
5.3.6	CS104 (Conducted susceptibility, antenna port, rejection of undesired signals, 30 Hz to 20 GHz)	13
5.3.6.1	CS104 applicability	13
5.3.6.2	CS104 limit	13
5.3.7	CS105 (Conducted susceptibility, antenna port, cross modulation, 30 Hz to 20 GHz)	13
5.3.7.1	CS105 applicability	13
5.3.7.2	CS105 limit	13
5.3.8	CS109 (Conducted susceptibility, structure current, 60 Hz to 100 kHz)	14
5.3.8.1	CS109 applicability	14
5.3.8.2	CS109 limit	14
5.3.9	CS114 (Conducted susceptibility, bulk cable injection, 10 kHz to 400 MHz)	14
5.3.9.1	CS114 applicability	14
5.3.9.2	CS114 limit	14
5.3.10	CS115 (Conducted susceptibility, bulk cable injection, impulse excitation)	16
5.3.10.1	CS115 applicability	16
5.3.10.2	CS115 limit	16

MIL-STD-461D

CONTENTS

<u>PARAGRAPH</u>		<u>PAGE</u>
5.3.11	CS116 (Conducted susceptibility, damped sinusoidal transients, cables and power leads, 10 kHz to 100 MHz)	16
5.3.11.1	CS116 applicability	16
5.3.11.2	CS116 limit	16
5.3.12	RE101 (Radiated emissions, magnetic field, 30 Hz to 100 kHz)	16
5.3.12.1	RE101 applicability	16
5.3.12.2	RE101 limit	17
5.3.13	RE102 (Radiated emissions, electric field, 10 kHz to 18 GHz)	17
5.3.13.1	RE102 applicability	17
5.3.13.2	RE102 limits	17
5.3.14	RE103 (Radiated emissions, antenna spurious and harmonic outputs, 10 kHz to 40 GHz)	17
5.3.14.1	RE103 applicability	17
5.3.14.2	RE103 limits	18
5.3.15	RS101 (Radiated susceptibility, magnetic field, 30 Hz to 100 kHz)	18
5.3.15.1	RS101 applicability	18
5.3.15.2	RS101 limit	18
5.3.16	RS103 (Radiated susceptibility, electric field, 10 kHz to 40 GHz)	18
5.3.16.1	RS103 applicability	18
5.3.16.2	RS103 limit	19
5.3.17	RS105 (Radiated susceptibility, transient electromagnetic field)	21
5.3.17.1	RS105 applicability	21
5.3.17.2	RS105 limit	21
6	NOTES	22
6.1	Intended use	22
6.2	Issue of DODISS	22
6.3	Data requirements	22
6.4	Subject term (key word) listing	23
6.5	International standardization agreements	23
6.6	Changes from previous issue	23
6.7	Technical points of contact	23
 <u>TABLE</u>		
I	Emission and susceptibility requirements	9
II	Requirement matrix	10
III	CS114 limit curves	15
IV	RS103 limits	20

MIL-STD-461D

CONTENTS

<u>FIGURE</u>		<u>PAGE</u>
CE101-1	CE101 limit (EUT power leads, DC only) for submarine applications	24
CE101-2	CE101 limit for surface ship and submarine applications, 60 Hz	25
CE101-3	CE101 limit for surface ship and submarine applications, 400 Hz	26
CE101-4	CE101 limit (power leads, AC and DC) for Navy ASW and Army aircraft (including flight line) applications	27
CE102-1	CE102 limit (EUT power leads, AC and DC) for all applications	28
CS101-1	CS101 limit (EUT power leads, AC and DC) for all applications	29
CS109-1	CS109 limit for all applications	30
CS114-1	CS114 calibration limit for all applications	31
CS115-1	CS115 calibrated signal source characteristics for all applications	32
CS116-1	Typical CS116 damped sinusoidal waveform	33
CS116-2	CS116 limit for all applications	34
RE101-1	RE101 limit (Navy only) for all applications	35
RE101-2	RE101 limit (Army only) for all applications	36
RE102-1	RE102 limit for surface ship and submarine applications	37
RE102-2	RE102 limit for aircraft and space system applications	38
RE102-3	RE102 limit for ground applications	39
RS101-1	RS101 limit (Navy only) for all applications	40
RS101-2	RS101 limit (Army only) for all applications	41
RS105-1	RS105 limit for all applications	42
 <u>APPENDIX</u>		
A	MIL-STD-461D Application Guide	A-1

MIL-STD-461D

1. SCOPE

1.1 Purpose. This standard establishes the design requirements for the control of the electromagnetic emission and susceptibility characteristics of electronic, electrical, and electromechanical equipment and subsystems designed or procured for use by activities and agencies of the Department of Defense. Such equipment and subsystems may be used independently or as an integral part of other subsystems or systems. Data item requirements are also included.

1.2 Application.

1.2.1 General applicability. The applicability of the emission and susceptibility requirements is dependent upon the types of equipment or subsystems and their intended installations as specified herein.

1.2.2 Tailoring of requirements. Application-specific environmental criteria may be derived from operational and engineering analyses on equipment or subsystems being procured for use in specific systems or platforms. When analyses reveal that the requirements in this standard are not appropriate for that procurement, the requirements may be tailored and incorporated into the request-for-proposal, specification, contract, order, and so forth.

1.3 Emission and susceptibility designations. The emissions and susceptibility requirements in this standard and corresponding test methods of MIL-STD-462 are designated in accordance with an alpha-numeric coding system. Each method is identified by a two letter combination followed by a three digit number. The number is for reference purposes only. The meaning of the individual letters are as follows:

C = Conducted
R = Radiated
E = Emission
S = Susceptibility

- a. Conducted emissions tests are designated by "CE---."
- b. Radiated emissions tests are designated by "RE---."
- c. Conducted susceptibility tests are designated by "CS---."
- d. Radiated susceptibility test are designated by "RS---."
- e. "----" = numerical order of test from 101 to 199.

MIL-STD-461D

2. APPLICABLE DOCUMENTS

2.1 Government documents.

2.1.1 Specifications, standards, and handbooks. The following specifications, standards, and handbooks form a part of this document to the extent specified herein. Unless otherwise specified, the issues of these documents are those listed in the issue of the Department of Defense Index of Specifications and Standards (DODISS) and supplement thereto, cited in the solicitation (see 6.2).

STANDARD

MILITARY

MIL-STD-462 - Measurement of Electromagnetic Interference Characteristics

(Unless otherwise indicated, copies of federal and military specifications, standards, and handbooks are available from the Naval Publications and Forms Center, ATTN: NPODS, 700 Robbins Avenue, Philadelphia, PA 19111-5093.)

2.1.2 Other Government documents, drawings, and publications. The following other Government documents, drawings, and publications form a part of this document to the extent specified herein. Unless otherwise specified, the issues are those cited in the solicitation.

DODISS	-	Department of Defense Index of Specifications and Standards
DOD Federal Acquisition Regulation Supplement, Part 27	-	Data Requirements.
DOD 5010.12-L	-	DOD Acquisition Management Systems and Data Requirement Control List (AMSDL).
DOD 5000.37-M	-	DOD Non Developmental Items Acquisition Manual

(Copies of the DOD 5010.12-L on a subscription basis and DOD 5000.37M are available from the Commanding Officer, Naval Publications and Forms Center, 700 Robbins Avenue, Philadelphia, PA 19111-5093. Copies of the DOD Federal Acquisition Regulation

MIL-STD-461D

Supplements are available from the Superintendent of Documents, U.S. Government Printing Office, Washington, DC 20402-0001. Copies of DODISS are available on a yearly subscription basis either from the Government Printing Office for hard copy, or microfiche copies are available from the Director, Navy Publications and Printing Service Office, 700 Robbins Avenue, Philadelphia, PA 19111-5093.)

2.2 Non-Government publications. The following documents form a part of this document to the extent specified herein. Unless otherwise specified, the issues of the documents which are DOD adopted are those listed in the issue of the DODISS cited in the solicitation. Unless otherwise specified, the issues of documents not listed in the DODISS are the issues of the documents cited in the solicitation (see 6.2).

AMERICAN NATIONAL STANDARDS INSTITUTE (ANSI)

ANSI C63.14 - Standard Dictionary for Technologies of Electromagnetic Compatibility (EMC), Electromagnetic Pulse (EMP), and Electrostatic Discharge (ESD).

ANSI/IEEE 268 - Metric Practice. (DOD adopted)

(Application for copies should be addressed to the IEEE Service Center, 445 Hoes Lane, PO Box 1331, Piscataway, NJ 08855-1331.)

AMERICAN SOCIETY FOR TESTING AND MATERIALS (ASTM)

ASTM E 380 - Standard for Metric Practice. (DOD adopted)

(Application for copies should be addressed to the American Society for Testing and Materials, 1916 Race Street, Philadelphia, PA 19103-1187.)

(Non-government standards are generally available for reference from libraries. They are also distributed among non-government standards bodies and using Federal agencies.)

2.3 Order of precedence. In the event of a conflict between the text of this standard and the references cited herein, the text of this standard shall take precedence. Nothing in this document, however, supersedes applicable laws and regulations unless a specific exemption has been obtained.

3. DEFINITIONS

3.1 General. The terms used in this standard are defined in ANSI C63.14. In addition, the following definitions are applicable for the purpose of this standard.

3.2 Acronyms used in this standard.

- a. ASW - Anti-submarine Warfare
- b. EMC - Electromagnetic Compatibility
- c. EME - Electromagnetic Environment
- d. EMI - Electromagnetic Interference
- e. EMICP - Electromagnetic Interference Control Procedures
- f. EMITP - Electromagnetic Interference Test Procedures
- g. EMITR - Electromagnetic Interference Test Report
- h. EUT - Equipment Under Test
- i. GFE - Government Furnished Equipment
- j. ISM - Industrial, Scientific and Medical
- k. NDI - Non-Developmental Item
- l. RMS - Root Mean Square

3.3 Above deck. An area on ships which is generally in the open air.

3.4 Below deck. An area on ships which is surrounded by a metallic structure, or an area which provides significant attenuation to electromagnetic radiation, such as the metal hull or superstructure of a surface ship, the hull of a submarine and the screened rooms in non-metallic ships.

3.5 External installation. An equipment location on a platform which is exposed to the external electromagnetic environment, such as an aircraft cockpit which does not use electrically conductive treatments on the canopy or windscreen.

3.6 Flight-line equipment. Any support equipment that is attached to or used next to an aircraft during pre-flight or

MIL-STD-461D

post-flight operations, such as uploading or downloading data, maintenance diagnostics, or equipment functional testing.

3.7 Internal installation. An equipment location on a platform which is totally inside an electrically conductive structure, such as a typical avionics bay in an aluminum skin aircraft.

3.8 Metric units. Metric units are a system of basic measures which are defined by the International System of Units based on "Le System International d'Unites (SI)", of the International Bureau of Weights and Measures. These units are described in ASTM E 380 and ANSI/IEEE 268.

3.9 Non-developmental item. Non-developmental item is a broad, generic term that covers material available from a wide variety of sources with little or no development effort required by the Government.

3.10 Safety critical. A category of subsystems and equipment whose degraded performance could result in loss of life or loss of vehicle or platform.

4. GENERAL REQUIREMENTS

4.1 General. Electronic, electrical, and electromechanical equipment and subsystems shall comply with the applicable requirements in 4.2 through 4.8. The requirements are in addition to the applicable emission and susceptibility requirements defined in other portions of this standard.

4.2 Joint procurement. Equipment or subsystems procured by one DOD activity for multi-agency use shall comply with the requirements of the user agencies.

4.3 Filtering (Navy only). The use of line-to-ground filters for EMI control shall be minimized. Such filters establish low impedance paths for structure (common-mode) currents through the ground plane and can be a major cause of interference in systems, platforms, or installations because the currents can couple into other equipment using the same ground plane. If such a filter must be employed, the line-to-ground capacitance for each line shall not exceed 0.1 microfarads (μF) for 60 Hertz (Hz) equipment or 0.02 μF for 400 Hz equipment. For submarine DC-powered equipment and aircraft DC-powered equipment, the filter capacitance from each line-to-ground at the user interface shall not exceed 0.075 $\mu\text{F}/\text{kW}$ of connected load. For loads less than 0.5 kW, the filter capacitance shall not exceed 0.03 μF . The filtering employed shall be fully described in the equipment or subsystem technical manual and the Electromagnetic Interference Control Procedures (EMICP) (See 6.3).

4.4 Self-compatibility. The operational performance of an equipment or subsystem shall not be degraded, nor shall it malfunction when all of the units or devices in the equipment or subsystem are operating together at their designed levels of efficiency or their design capability.

4.5 Non-Developmental Items (NDI). In accordance with the guidance provided by DOD 5000.37-M, the requirements of this standard shall be met when applicable and warranted by the intended installation and platform requirements.

4.5.1 Commercial off-the-shelf equipment.

4.5.1.1 Selected by contractor. When it is demonstrated that a commercial item selected by the contractor is responsible for equipment or subsystems failing to meet the contractual EMI requirements, either the commercial item shall be modified or replaced or interference suppression measures shall be employed, so that the equipment or subsystems meet the contractual EMI requirements.

4.5.1.2 Specified by procuring activity. When it is demonstrated by the contractor that a commercial item specified by the procuring activity for use in an equipment or subsystem is responsible for failure of the equipment or subsystem to meet its contractual EMI requirements, the data indicating such failure shall be included in the Electromagnetic Interference Test Report (EMITR) (See 6.3). No modification or replacement shall be made unless authorized by the procuring activity.

4.5.2 Procurement of equipment or subsystems having met other EMI requirements. Procurement of equipment and subsystems electrically and mechanically identical to those previously procured by activities of DOD or other Federal agencies, or their contractors, shall meet the EMI requirements and associated limits, as applicable in the earlier procurement, unless otherwise specified by the Command or agency concerned.

4.6 Government Furnished Equipment (GFE). When it is demonstrated by the contractor that a GFE is responsible for failure of an equipment or subsystem to meet its contractual EMI requirements, the data indicating such failure shall be included in the EMITR (See 6.3). No modification shall be made unless authorized by the procuring activity.

4.7 Testing requirements. The testing requirements and procedures of MIL-STD-462 shall be used to determine compliance with the applicable emission and susceptibility requirements of this standard. Data gathered as a result of performing tests in one electromagnetic discipline may be sufficient to satisfy requirements in another. Therefore, to avoid unnecessary duplication, a single test program should be established with tests for similar requirements conducted concurrently whenever possible. Equipment that are intended to be operated as a subsystem shall be tested as such to the applicable emission and susceptibility requirements whenever practical. Formal testing is not to commence without approval of the Electromagnetic Interference Test Procedures (EMITP) (See 6.3) by the Command or agency concerned.

4.8 Switching transients. Switching transient emissions that result at the moment of operation of manually actuated switching functions are exempt from the requirements of this standard. Other transient type conditions, such as automatic sequencing following initiation by a manual switching function, shall meet the emissions requirements of this standard.

MIL-STD-461D

5. DETAILED REQUIREMENTS

5.1 General. Table I is a list of emissions and susceptibility requirements established by this standard. General test methods for these requirements are contained in MIL-STD-462 as implemented by the Government approved EMITP (See 6.3). All results of tests performed to demonstrate compliance with the requirements are to be documented in the EMITR (See 6.3) and forwarded to the Command or agency concerned for evaluation prior to acceptance of the equipment or subsystem. Design procedures and techniques for the control of EMI shall be described in the EMICP (See 6.3). Approval of design procedures and techniques described in the EMICP does not relieve the supplier of the responsibility of meeting the contractual emission, susceptibility, and design requirements.

MIL-STD-461D

TABLE I. Emission and susceptibility requirements.

Requirement	Description
CE101	Conducted Emissions, Power Leads, 30 Hz to 10 kHz
CE102	Conducted Emissions, Power Leads, 10 kHz to 10 MHz
CE106	Conducted Emissions, Antenna Terminal, 10 kHz to 40 GHz
CS101	Conducted Susceptibility, Power Leads, 30 Hz to 50 kHz
CS103	Conducted Susceptibility, Antenna Port, Intermodulation, 15 kHz to 10 GHz
CS104	Conducted Susceptibility, Antenna Port, Rejection of Undesired Signals, 30 Hz to 20 GHz
CS105	Conducted Susceptibility, Antenna Port, Cross-Modulation, 30 Hz to 20 GHz
CS109	Conducted Susceptibility, Structure Current, 60 Hz to 100 kHz
CS114	Conducted Susceptibility, Bulk Cable Injection, 10 kHz to 400 MHz
CS115	Conducted Susceptibility, Bulk Cable Injection, Impulse Excitation
CS116	Conducted Susceptibility, Damped Sinusoidal Transients, Cables and Power Leads, 10 kHz to 100 MHz
RE101	Radiated Emissions, Magnetic Field, 30 Hz to 100 kHz
RE102	Radiated Emissions, Electric Field, 10 kHz to 18 GHz
RE103	Radiated Emissions, Antenna Spurious and Harmonic Outputs, 10 kHz to 40 GHz
RS101	Radiated Susceptibility, Magnetic Field, 30 Hz to 100 kHz
RS103	Radiated Susceptibility, Electric Field, 10 kHz to 40 GHz
RS105	Radiated Susceptibility, Transient Electromagnetic Field

MIL-STD-461D

5.1.1 Units of frequency domain measurements. All frequency domain limits are expressed in terms of equivalent Root Mean Square (RMS) value of a sine wave as would be indicated by the output of a measurement receiver using peak envelope detection.

5.2 EMI control requirements versus intended installations. Table II summarizes the requirements for equipment and subsystems intended to be installed in, on, or launched from various military platforms or installations. When an equipment or subsystem is to be installed in more than one type of platform or installation, it shall comply with the most stringent of the applicable requirements and limits. An "A" entry in the table means the requirement is applicable. An "L" entry means the applicability of the requirement is limited as specified in the appropriate requirement paragraphs of this standard; the limits are contained herein. An "S" entry means the procuring activity must specify the applicability and limit requirements in the procurement specification. Absence of an entry means the requirement is not applicable.

TABLE II. Requirement matrix.

Equipment and Subsystems Installed In, On, or Launched From the Following Platforms or Installations	Requirement Applicability																
	CE101	CE102	CE106	CS101	CS103	CS104	CS105	CS109	CS114	CS115	CS116	RE101	RE102	RE103	RS101	RS103	RS105
Surface Ships	A	A	L	A	S	S	S		A		A	A	A	L	A	A	L
Submarines	A	A	L	A	S	S	S	L	A		A	A	A	L	A	A	L
Aircraft, Army, Including Flight Line	A	A	L	A	S	S	S		A	A	L	A	A	L	A	A	L
Aircraft, Navy	L	A	L	A	S	S	S		A	A	A	L	A	L	L	A	L
Aircraft, Air Force		A	L	A	S	S	S		A	A	A		A	L		A	
Space Systems, Including Launch Vehicles		A	L	A	S	S	S		A	A	A		A	L		A	
Ground, Army		A	L	A	S	S	S		A	L	L		A	L	L	A	
Ground, Navy		A	L	A	S	S	S		A		A		A	L	L	A	L
Ground, Air Force		A	L	A	S	S	S		A	L	A		A	L		A	

5.3 Emission and susceptibility requirements and limits.

5.3.1 CE101 (Conducted emissions, power leads, 30 Hz to 10 kHz).

5.3.1.1 CE101 applicability. This requirement is applicable as follows for power leads, including returns, that obtain power from other sources not part of the EUT.

- a. Not applicable Air Force
- b. AC leads only Ships
- c. AC and DC leads . . . Submarines, Army Aircraft[†]
(including flight line) and Navy Aircraft*[†]

*For equipment intended to be installed on Navy aircraft, this requirement is applicable only for aircraft with Anti-Submarine Warfare (ASW) capability.

[†]For AC applications, this requirement is applicable starting at the second harmonic of the EUT power frequency.

5.3.1.2 CE101 limits. Conducted emissions on power leads shall not exceed the applicable values shown on Figures CE101-1 through CE101-3, as appropriate, for ships and submarines and Figure CE101-4 for Army aircraft (including flight line) and Navy ASW aircraft.

5.3.2 CE102 (Conducted emissions, power leads, 10 kHz to 10 MHz).

5.3.2.1 CE102 applicability. This requirement is applicable from 10 kHz to 10 MHz for all power leads, including returns, that obtain power from other sources not part of the EUT.

5.3.2.2 CE102 limits. Conducted emissions on power leads shall not exceed the applicable values shown on Figure CE102-1.

5.3.3 CE106 (Conducted emissions, antenna terminal, 10 kHz to 40 GHz).

5.3.3.1 CE106 applicability. This requirement is applicable to the antenna terminals of transmitters and receivers. The requirement is not applicable to equipment designed to operate into a non-removable antenna. The transmitter (transmit mode) portion of this requirement is not applicable within either the EUT necessary bandwidth or ± 5

MIL-STD-461D

percent of the fundamental frequency. Depending on the operating frequency range of the EUT, the start frequency of the test is as follows:

<u>Operating Frequency Range (EUT)</u>	<u>Start Frequency of Test</u>
10 kHz to 3 MHz	10 kHz
3 MHz to 300 MHz	100 kHz
300 MHz to 3 GHz	1 MHz
3 GHz to 40 GHz	10 MHz

The end frequency of the test is 40 GHz or twenty times the highest generated or received frequency within the EUT, whichever is less. For equipment using waveguide, the requirement does not apply below eight-tenths of the waveguide's cutoff frequency. Requirement RE103 may be used as an alternative for CE106 for testing transmitters with their operational antennas.

5.3.3.2 CE106 limits. Conducted emissions at the EUT antenna terminal shall not exceed the values given below.

- a. Receivers: 34 dB μ V
- b. Transmitters (standby mode): 34 dB μ V
- c. Transmitters (transmit mode): Harmonics, except the second and third, and all other spurious emissions shall be at least 80 dB down from the level at the fundamental. The second and third harmonics shall be suppressed $50 + 10 \log p$ (where p = peak power output in watts, at the fundamental) or 80 dB, whichever requires less suppression.

5.3.4 CS101 (Conducted susceptibility, power leads, 30 Hz to 50 kHz).

5.3.4.1 CS101 applicability. This requirement is applicable to equipment and subsystem AC and DC input power leads, not including returns. If the EUT is DC operated, this requirement is applicable over the frequency range of 30 Hz to 50 kHz. If the EUT is AC operated, this requirement is applicable starting from the second harmonic of the EUT power frequency and extending to 50 kHz.

5.3.4.2 CS101 limit. The EUT shall not exhibit any malfunction, degradation of performance, or deviation from specified indications, beyond the tolerances indicated in the

MIL-STD-461D

individual equipment or subsystem specification, when subjected to a test signal with levels as specified in Figure CS101-1. The requirement is also met under the following condition: when the power source specified in MIL-STD-462, adjusted to dissipate 80 watts in a 0.5 ohm load, cannot develop the required voltage at the EUT power input terminals, and the EUT is not susceptible to the output of the signal source.

5.3.5 CS103 (Conducted susceptibility, antenna port, intermodulation, 15 kHz to 10 GHz).

5.3.5.1 CS103 applicability. This receiver front-end susceptibility requirement is applicable to equipment and subsystems, such as communications receivers, RF amplifiers, transceivers, radar receivers, acoustic receivers, and electronic warfare receivers as specified in the individual procurement specification.

5.3.5.2 CS103 limit. The EUT shall not exhibit any intermodulation products beyond specified tolerances when subjected to the limit requirement provided in the individual procurement specification.

5.3.6 CS104 (Conducted susceptibility, antenna port, rejection of undesired signals, 30 Hz to 20 GHz).

5.3.6.1 CS104 applicability. This receiver front-end susceptibility requirement is applicable to equipment and subsystems, such as communications receivers, RF amplifiers, transceivers, radar receivers, acoustic receivers, and electronic warfare receivers as specified in the individual procurement specification.

5.3.6.2 CS104 limit. The EUT shall not exhibit any undesired response beyond specified tolerances when subjected to the limit requirement provided in the individual procurement specification.

5.3.7 CS105 (Conducted susceptibility, antenna port, cross modulation, 30 Hz to 20 GHz).

5.3.7.1 CS105 applicability. This receiver front-end susceptibility requirement is applicable only to receivers that normally process amplitude-modulated RF signals, as specified in the individual procurement specification.

5.3.7.2 CS105 limit. The EUT shall not exhibit any undesired response, due to cross modulation, beyond specified tolerances when subjected to the limit requirement provided in the individual procurement specification.

5.3.8 CS109 (Conducted susceptibility, structure current, 60 Hz to 100 kHz).

5.3.8.1 CS109 applicability. This requirement is applicable to equipment and subsystems that have an operating frequency range of 100 kHz or less and an operating sensitivity of 1 μ V or less (such as 0.5 μ V). Handheld equipment is exempt from this requirement.

5.3.8.2 CS109 limit. The EUT shall not exhibit any malfunction, degradation of performance, or deviation from specified indications, beyond the tolerances indicated in the individual equipment or subsystem specification, when subjected to the values shown on Figure CS109-1.

5.3.9 CS114 (Conducted susceptibility, bulk cable injection, 10 kHz to 400 MHz).

5.3.9.1 CS114 applicability. This requirement is applicable to all interconnecting cables, including power cables. The requirement is applicable to equipment and subsystems, based on the intended installation as follows:

- a. 10 kHz to 2 MHz . . all
- b. 2 MHz to 30 MHz . . all
- c. 30 MHz to 200 MHz . . aircraft (Air Force and Army);
space systems; and optional* for
all others
- d. 200 MHz to 400 MHz . . optional* for all

*Required only if specified in the procurement specification

5.3.9.2 CS114 limit. The EUT shall not exhibit any malfunction, degradation of performance, or deviation from specified indications beyond the tolerances indicated in the individual equipment or subsystem specification, when subjected to a test signal with calibration levels as shown in Figure CS114-1. The appropriate limit curve in Figure CS114-1 shall be selected from Table III. The requirements are also met if the following currents are induced in the cable under test and the EUT is not susceptible:

Curve 5: 115 dB μ A
 Curve 4: 103 dB μ A
 Curve 3: 95 dB μ A
 Curve 2: 89 dB μ A
 Curve 1: 83 dB μ A

TABLE III. CS114 limit curves.

PLATFORM FREQ. RANGE		LIMIT CURVE # FROM FIGURE CS114-1									
		AIRCRAFT (EXTERNAL OR SAFETY CRITICAL)	AIRCRAFT (INTERNAL)	ALL SHIPS (ABOVE DECKS)	SHIPS (METALLIC) (BELOW DECKS)	SHIPS (NON- METALLIC) (BELOW DECKS)	SUB- MARINES	GROUND	SPACE		
10 kHz ↓ 2 MHz	A	5	5	2	2	2	1	3	3		
	N	5	3	2	2	2	1	2	3		
	AF	5	3	-	-	-	-	2	3		
2 MHz ↓ 30 MHz	A	5	5	5	2	4	1	4	3		
	N	5	5	5	2	4	1	2	3		
	AF	5	3	-	-	-	-	2	3		
30 MHz ↓ 200 MHz	A	5	5	5	2	2	1	4	3		
	N	-	-	5	2	2	1	2	3		
	AF	5	3	-	-	-	-	2	3		
200 MHz ↓ 400 MHz	A	5	5	5	2	2	1	4	3		
	N	-	-	5	2	2	1	2	3		
	AF	5	3	-	-	-	-	2	3		
200 MHz ↓ 400 MHz	A	5	5	5	2	2	1	4	3		
	N	-	-	5	2	2	1	2	3		
	AF	5	3	-	-	-	-	2	3		

KEY: A = Army
 N = Navy
 AF = Air Force

5.3.10 CS115 (Conducted susceptibility, bulk cable injection, impulse excitation).

5.3.10.1 CS115 applicability. This requirement is applicable to all aircraft and space system interconnecting cables, including power cables. The requirement is also applicable for Army and Air Force ground subsystems and equipment when specified by the procuring activity.

5.3.10.2 CS115 limit. The EUT shall not exhibit any malfunction, degradation of performance, or deviation from specified indications, beyond the tolerances indicated in the individual equipment or subsystems specification, when subjected to a calibrated test signal as specified in Figure CS115-1 at a 30 Hz rate for one minute.

5.3.11 CS116 (Conducted susceptibility, damped sinusoidal transients, cables and power leads, 10 kHz to 100 MHz).

5.3.11.1 CS116 applicability. This requirement is applicable to all interconnecting cables, including power cables, and individual power leads. Power returns need not be tested individually. For Air Force ground subsystems and equipment, this requirement is applicable only for power cables and individual power leads. The requirement is also applicable for Army ground subsystems and equipment, including flight line, when specified by the procuring activity.

5.3.11.2 CS116 limit. The EUT shall not exhibit any malfunction, degradation of performance, or deviation from specified indications, beyond the tolerances indicated in the individual equipment or subsystem specification, when subjected to a signal having the waveform shown in Figure CS116-1 and having a maximum current as specified in Figure CS116-2. As a minimum, compliance shall be demonstrated at the following frequencies: .01, .1, 1, 10, 30, 100 MHz, and resonant frequencies as determined in accordance with MIL-STD-462. The test signal repetition rate shall be no greater than one pulse per second and no less than one pulse every two seconds. The pulses shall be applied for a period of five minutes.

5.3.12 RE101 (Radiated emissions, magnetic field, 30 Hz to 100 kHz).

5.3.12.1 RE101 applicability. This requirement is applicable for radiated emissions from equipment and subsystem enclosures, and all interconnecting cables. The requirement does not apply at telecommunication transmitter fundamental frequencies, but does apply to the operating frequencies of sonar and industrial, scientific, and medical (ISM) subsystems and

equipment. The requirement does not apply to radiation from antennas. For Navy aircraft, this requirement is applicable only for aircraft with an ASW capability.

5.3.12.2 RE101 limit. Magnetic field emissions shall not be radiated in excess of the levels shown in Figures RE101-1 and RE101-2 at the specified distances of 7 centimeters and 50 centimeters.

5.3.13 RE102 (Radiated emissions, electric field, 10 kHz to 18 GHz).

5.3.13.1 RE102 applicability. This requirement is applicable for radiated emissions from equipment and subsystem enclosures, and all interconnecting cables. The requirement does not apply at the transmitter fundamental frequencies or to radiation from antennas. The requirement is applicable as follows:

- a. Ground 2 MHz to 18 GHz*
- b. Ships, surface 10 kHz to 18 GHz*
- c. Submarines 10 kHz to 1 GHz
- d. Aircraft (Army) 10 kHz to 18 GHz
- e. Aircraft (Air Force and Navy) 2 MHz to 18 GHz*

*Testing is required up to 1 GHz or 10 times the highest intentionally generated frequency within the EUT, whichever is greater. Measurements beyond 18 GHz are not required.

5.3.13.2 RE102 limits. Electric field emissions shall not be radiated in excess of those shown in Figures RE102-1 through RE102-3. Above 30 MHz, the limits shall be met for both horizontally and vertically polarized fields.

5.3.14 RE103 (Radiated emissions, antenna spurious and harmonic outputs, 10 kHz to 40 GHz).

5.3.14.1 RE103 applicability. This requirement may be used as an alternative for CE106 when testing transmitters with their intended antennas. CE106 is the preferred requirement unless the equipment or subsystem design characteristics preclude its use. The requirement is not applicable within either the EUT necessary bandwidth or ± 5 percent of the fundamental frequency. Depending on the operating frequency range of the EUT, the start frequency of the test is as follows:

<u>Operating Frequency Range (EUT)</u>	<u>Start Frequency of Test</u>
10 kHz to 3 MHz	10 kHz
3 MHz to 300 MHz	100 kHz
300 MHz to 3 GHz	1 MHz
3 GHz to 40 GHz	10 MHz

The end frequency of the test is 40 GHz or twenty times the highest generated frequency within the EUT, whichever is less. For equipment using waveguide, the requirement does not apply below eight-tenths of the waveguide's cutoff frequency.

5.3.14.2 RE103 limits. Harmonics, except the second and third, and all other spurious emissions shall be at least 80 dB down from the level at the fundamental. The second and third harmonics shall be suppressed $50 + 10 \log p$ (where p = peak power output in watts, at the fundamental) or 80 dB, whichever requires less suppression.

5.3.15 RS101 (Radiated susceptibility, magnetic field, 30 Hz to 100 kHz).

5.3.15.1 RS101 applicability. This requirement is applicable to equipment and subsystem enclosures, and all interconnecting cables. The requirement is not applicable for electromagnetic coupling via antennas. For equipment intended to be installed on Navy aircraft, the requirement is applicable only to aircraft with ASW capability. For Army ground equipment, the requirement is applicable only to vehicles having a minesweeping or mine detection capability. The requirement is applicable for Navy ground equipment when specified by the procuring activity.

5.3.15.2 RS101 limit. The EUT shall not exhibit any malfunction, degradation of performance, or deviation from specified indications, beyond the tolerances indicated in the individual equipment or subsystem specification, when subjected to the magnetic fields shown in Figures RS101-1 and RS101-2.

5.3.16 RS103 (Radiated susceptibility, electric field, 10 kHz to 40 GHz).

5.3.16.1 RS103 applicability. This requirement is applicable to equipment and subsystem enclosures and all interconnecting cables. The requirement is applicable as follows:

MIL-STD-461D

- a. 10 kHz to 2 MHz . . . Army aircraft, including flight line; and optional* for all others
- b. 2 MHz to 30 MHz . . . Army ships; Army aircraft, including flight line; Navy; and optional* for all others
- c. 30 MHz to 1 GHz . . . all
- d. 1 GHz to 18 GHz . . . all
- e. 18 GHz to 40 GHz . . . optional* for all

*Required only if specified in the procurement specification

The requirement is not applicable at the tuned frequency of an antenna-connected receiver unless otherwise specified by the procuring activity.

5.3.16.2 RS103 limit. The EUT shall not exhibit any malfunction, degradation of performance, or deviation from specified indications, beyond the tolerances indicated in the individual equipment or subsystem specification, when subjected to the radiated electric fields specified in Table IV. Up to 30 MHz, the requirement shall be met for vertically polarized fields. Above 30 MHz, the requirement shall be met for both horizontally and vertically polarized fields. Circular polarized fields are not acceptable.

TABLE IV. RS103 limits.

PLATFORM		LIMIT LEVEL (VOLTS/METER)									
FREQ. RANGE		AIRCRAFT (EXTERNAL OR SAFETY CRITICAL)	AIRCRAFT (INTERNAL)	ALL SHIPS (ABOVE DECKS)	SHIPS (METALLIC) (BELOW DECKS)	SHIPS (NON-METALLIC) (BELOW DECKS)	SUB-MARINES	GROUND	SPACE		
10 kHz ↓ 2 MHz	A	200	200	10	10	10	5	20	20		
	N	200	20	10	10	10	5	10	20		
	AF	200	20	-	-	-	-	10	20		
2 MHz ↓ 30 MHz	A	200	200	200	10	50	5	50	20		
	N	200	200	200	10	50	5	10	20		
	AF	200	20	-	-	-	-	10	20		
30 MHz ↓ 1 GHz	A	200	200	200	10	10	5	50	20		
	N	200	200	200	10	10	5	10	20		
	AF	200	20	-	-	-	-	10	20		
1 GHz ↓ 18 GHz	A	200	200	200	10	10	5	50	20		
	N	200	200	200	10	10	5	50	20		
	AF	200	60	-	-	-	-	50	20		
18 GHz ↓ 40 GHz	A	200	200	200	10	10	5	50	20		
	N	200	60	200	10	10	5	50	20		
	AF	200	60	-	-	-	-	50	20		

KEY: A = Army
 N = Navy
 AF = Air Force

5.3.17 RS105 (Radiated susceptibility, transient electromagnetic field).

5.3.17.1 RS105 applicability. This requirement is applicable to equipment and subsystem enclosures when the equipment or subsystem is to be located external to a hardened (shielded) platform or facility. The requirement is applicable for equipment intended solely for use on non-metallic platforms when specified by the procuring activity. The requirement is applicable to Army aircraft for safety critical equipment and subsystems located in an external installation.

5.3.17.2 RS105 limit. The EUT shall not exhibit any malfunction, degradation of performance, or deviation from specified indications, beyond the tolerances indicated in the individual equipment or subsystem specification, when subjected to a test signal having the waveform and amplitude shown on Figure RS105-1. At least five pulses shall be applied at the rate of not more than one pulse per minute.

6. NOTES

(This section contains information of a general or explanatory nature that may be helpful, but is not mandatory.)

6.1 Intended use. This standard is intended for use in the acquisition cycle of equipment and subsystems to specify the electromagnetic emission and susceptibility requirements for the control of EMI.

6.2 Issue of DODISS. When this standard is used in acquisition, the applicable issue of the DODISS must be cited in the solicitation (see 2.1.1 and 2.2).

6.3 Data requirements. The following Data Item Descriptions (DID's) must be listed, as applicable, on the Contract Data Requirements List (DD Form 1423) when this standard is applied on a contract, in order to obtain the data, except where DOD FAR Supplement 27.475-1 exempts the requirement from a DD Form 1423.

<u>Referenced Paragraph</u>	<u>DID Number</u>	<u>DID Title</u>
5.1	DI-EMCS-80199A	Electromagnetic Interference Control Procedures (EMICP)
5.1	DI-EMCS-80201A	Electromagnetic Interference Test Procedures (EMITP)
5.1	DI-EMCS-80200A	Electromagnetic Interference Test Report (EMITR)

The above DID's were those cleared as of the date of this standard. The current issue of DOD 5010,12-L, Acquisition Management Systems and Data Requirements Control List (AMSDL), must be researched to ensure that only current, cleared DID's are cited on the DD Form 1423.

6.4 Subject term (key word) listing.

EMC
EMI
Electromagnetic compatibility
Electromagnetic emission
Electromagnetic interference
Electromagnetic susceptibility
Test Limits, EMI
Test Methods, EMI

6.5 International standardization agreements. Certain provisions of this standard may be the subject of international standardization agreements. When amendment, revision, or cancellation of this standard is proposed which will modify the international agreement concerned, the preparing activity will take appropriate action through international standardization channels, including departmental standardization offices to change the agreement or make other appropriate accommodation.

6.6 Changes from previous issue. Marginal notations are not used in the revision to identify changes with respect to the previous issue due to the extensiveness of the changes.

6.7 Technical points of contact. Requests for additional information or assistance on this standard can be obtained from the following:

- a. Commander, U.S. Army, CECOM
AMSEL-RD-C3-EM-F
Ft. Monmouth, NJ 07703-5203
DSN 995-4220; Commercial (908) 544-4220
- b. Commander, Space and Naval Warfare Systems Command
SPAWAR 2243
Washington, DC 20363-5100
DSN 332-0559; Commercial (703) 602-4396
- c. ASC/ENACE
Wright Patterson AFB, OH 45433-6503
DSN 785-5078; Commercial (513) 255-5078

Any information relating to Government contracts must be obtained through contracting officers.

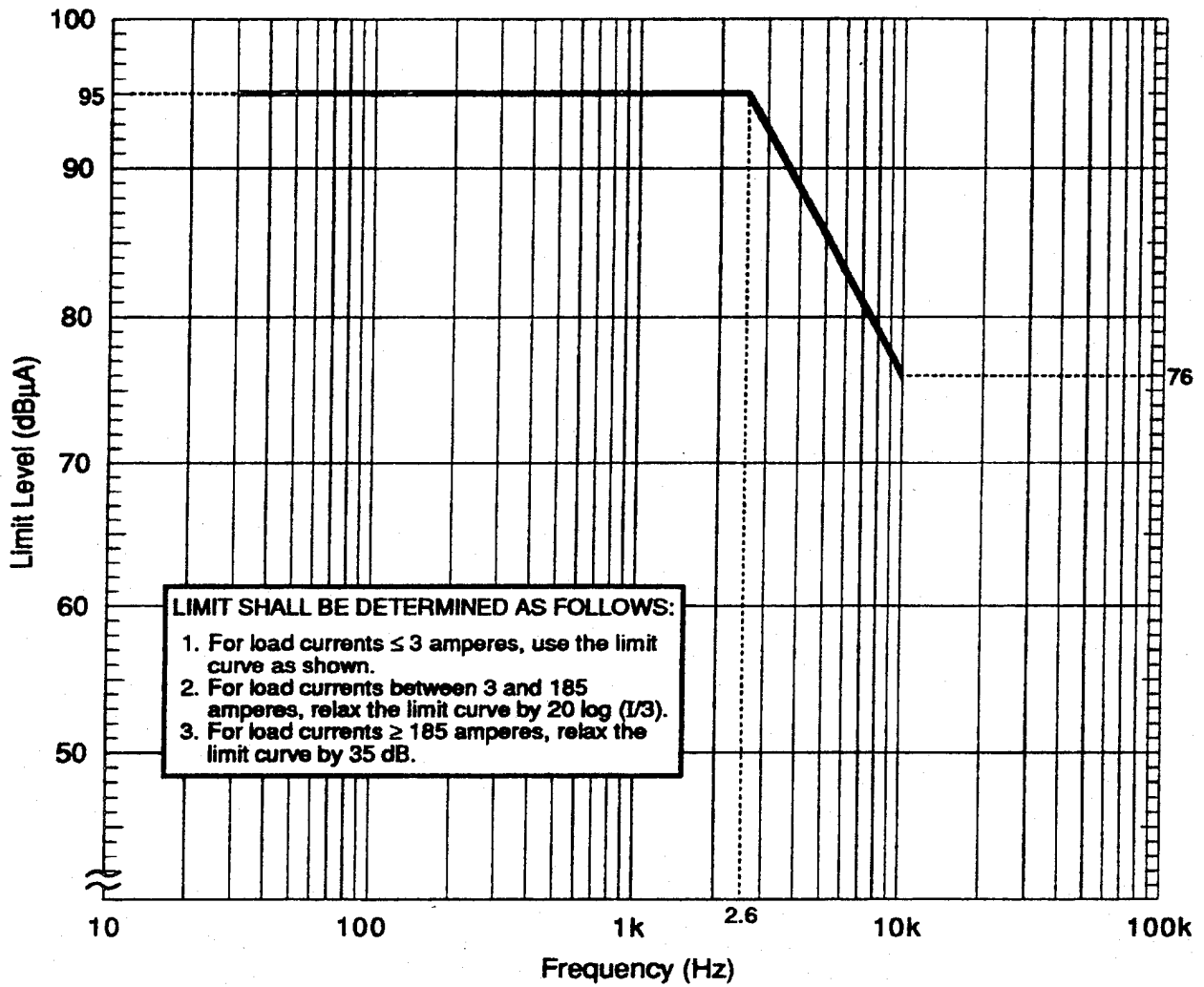

FIGURE CE101-1. CE101 limit (EUT power leads, DC only) for submarine applications.

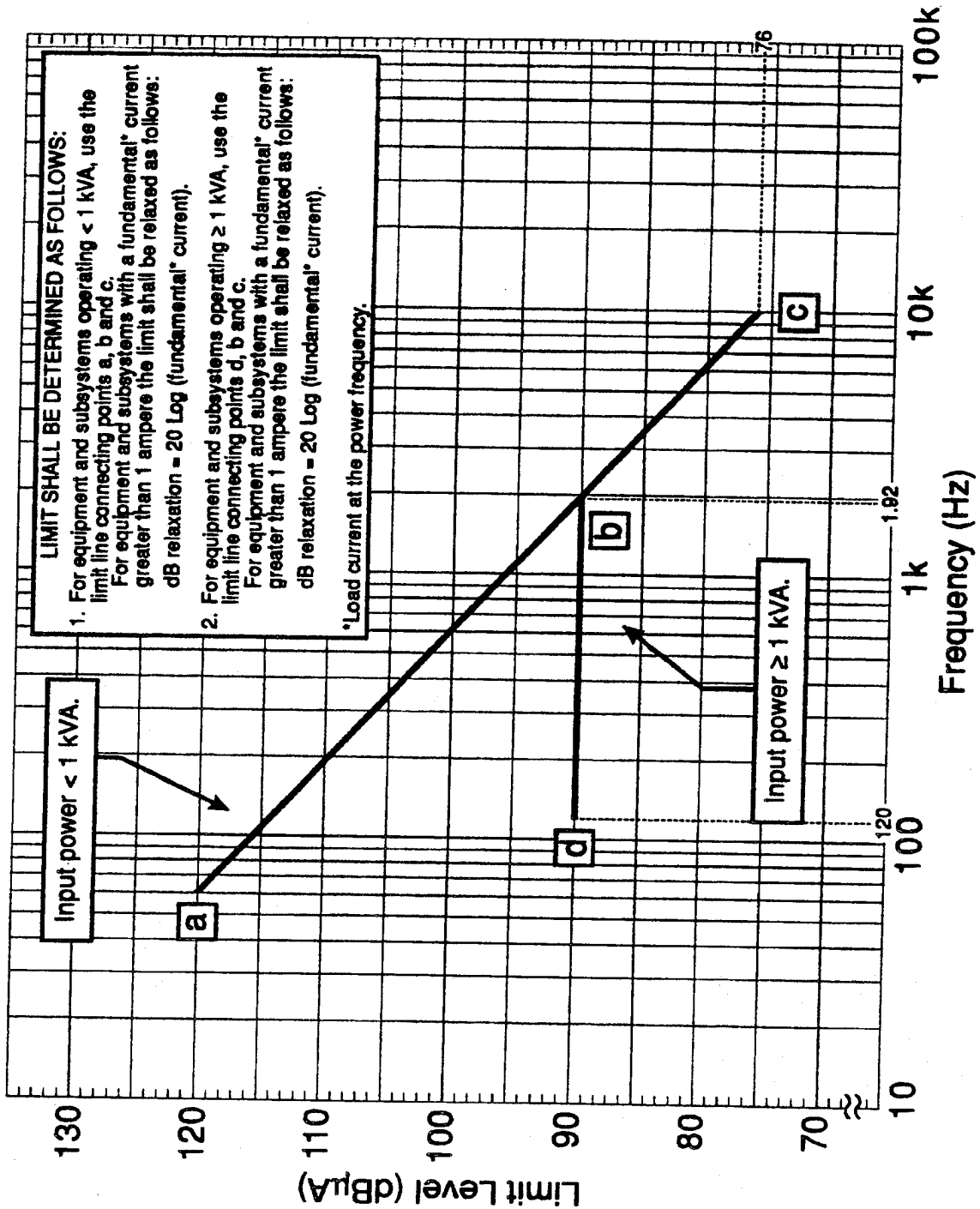

FIGURE CE101-2. CE101 limit for surface ship and submarine applications, 60 Hz.

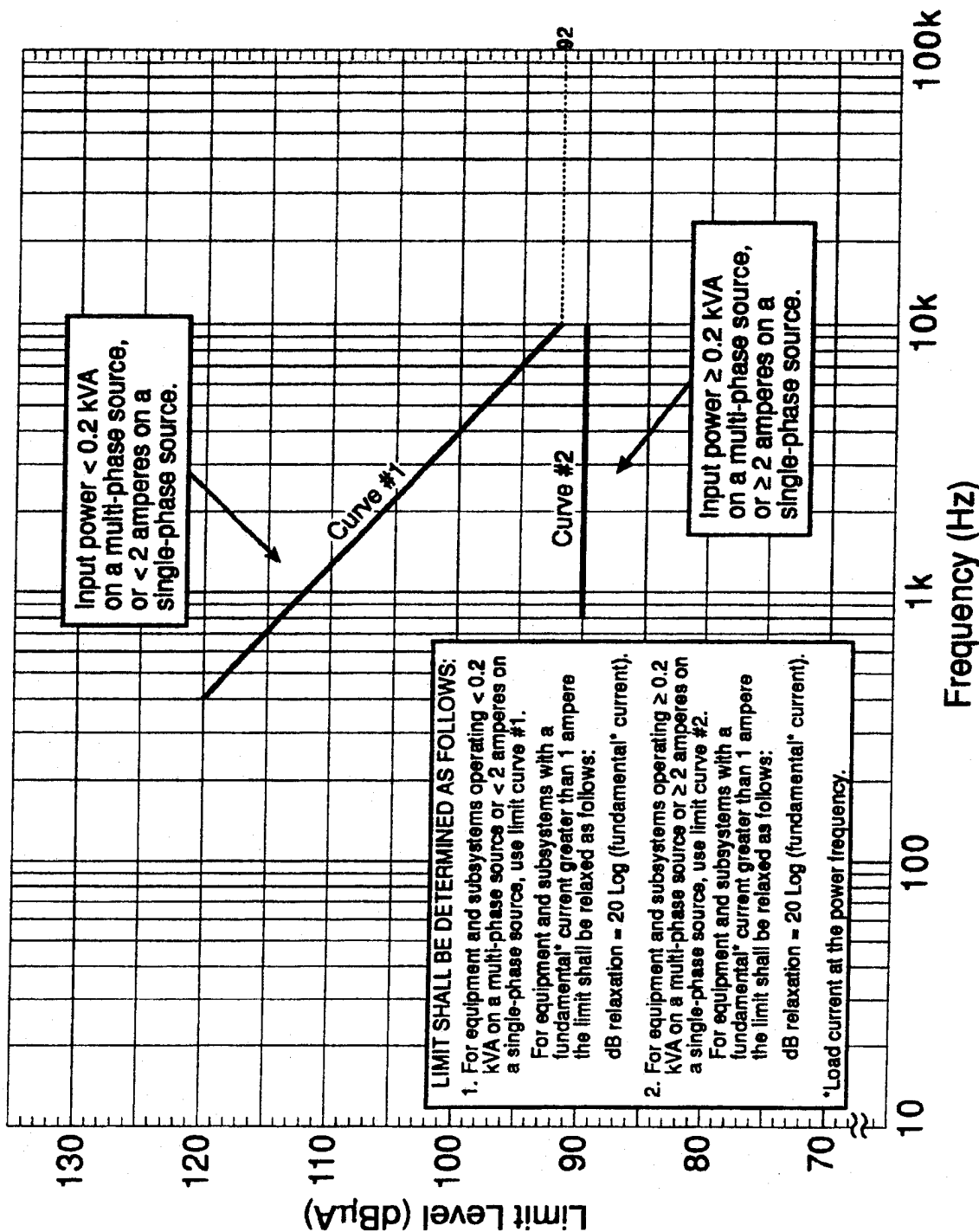

FIGURE CE101-3. CE101 limit for surface ship and submarine applications, 400 Hz.

MIL-STD-461D

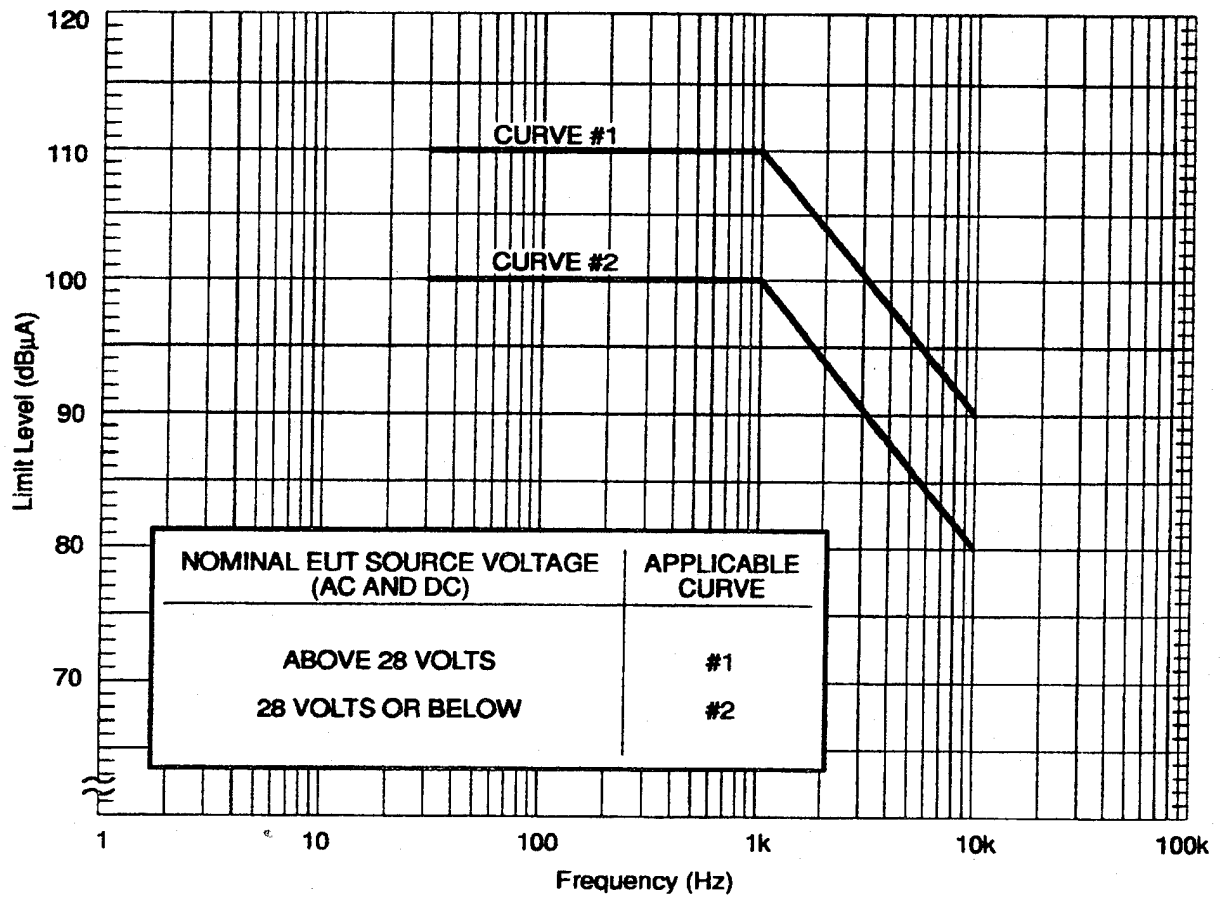

FIGURE CE101-4. CE101 limit (EUT power leads, AC and DC) for Navy ASW and Army aircraft (including flight line) applications.

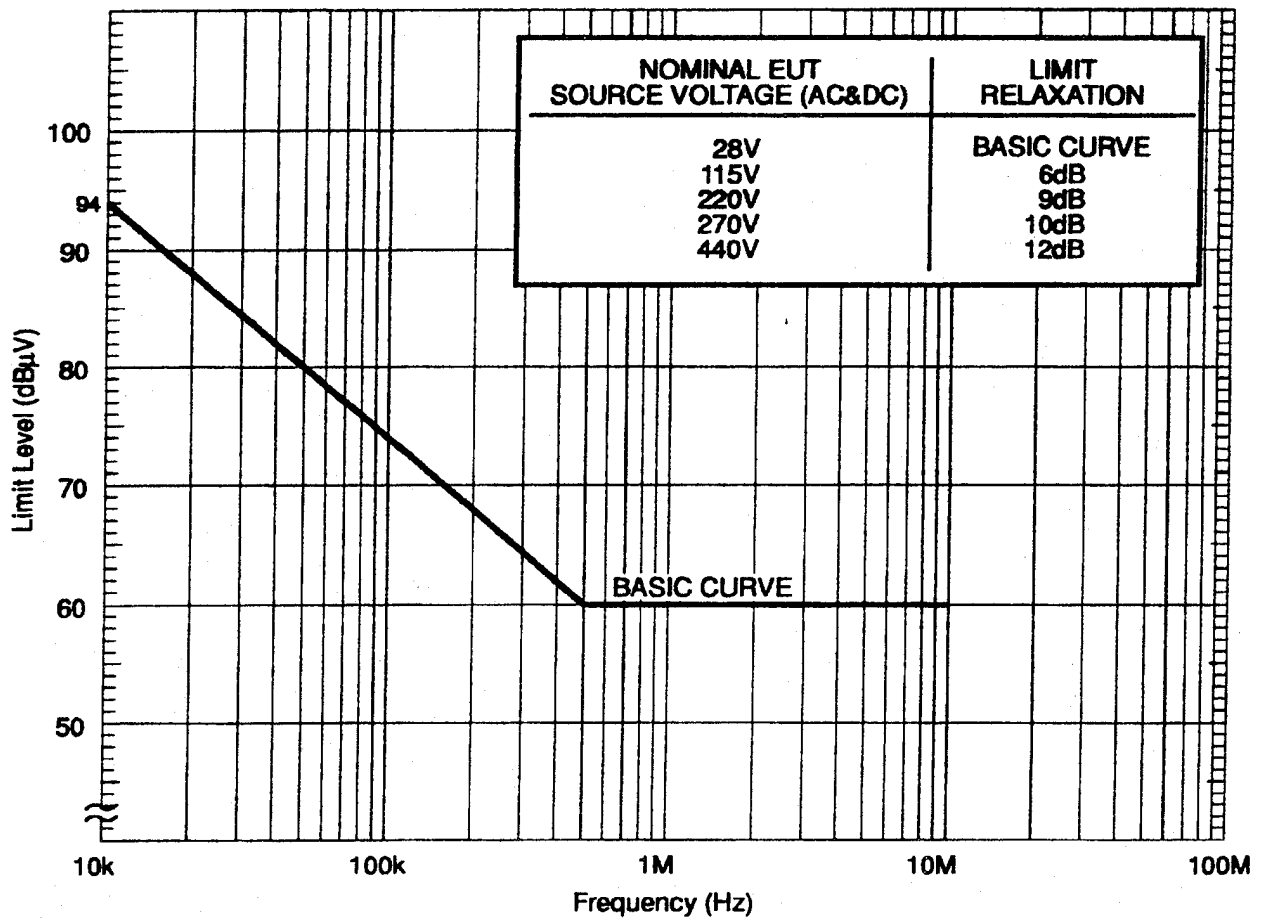

FIGURE CE102-1. CE102 limit (EUT power leads, AC and DC) for all applications.

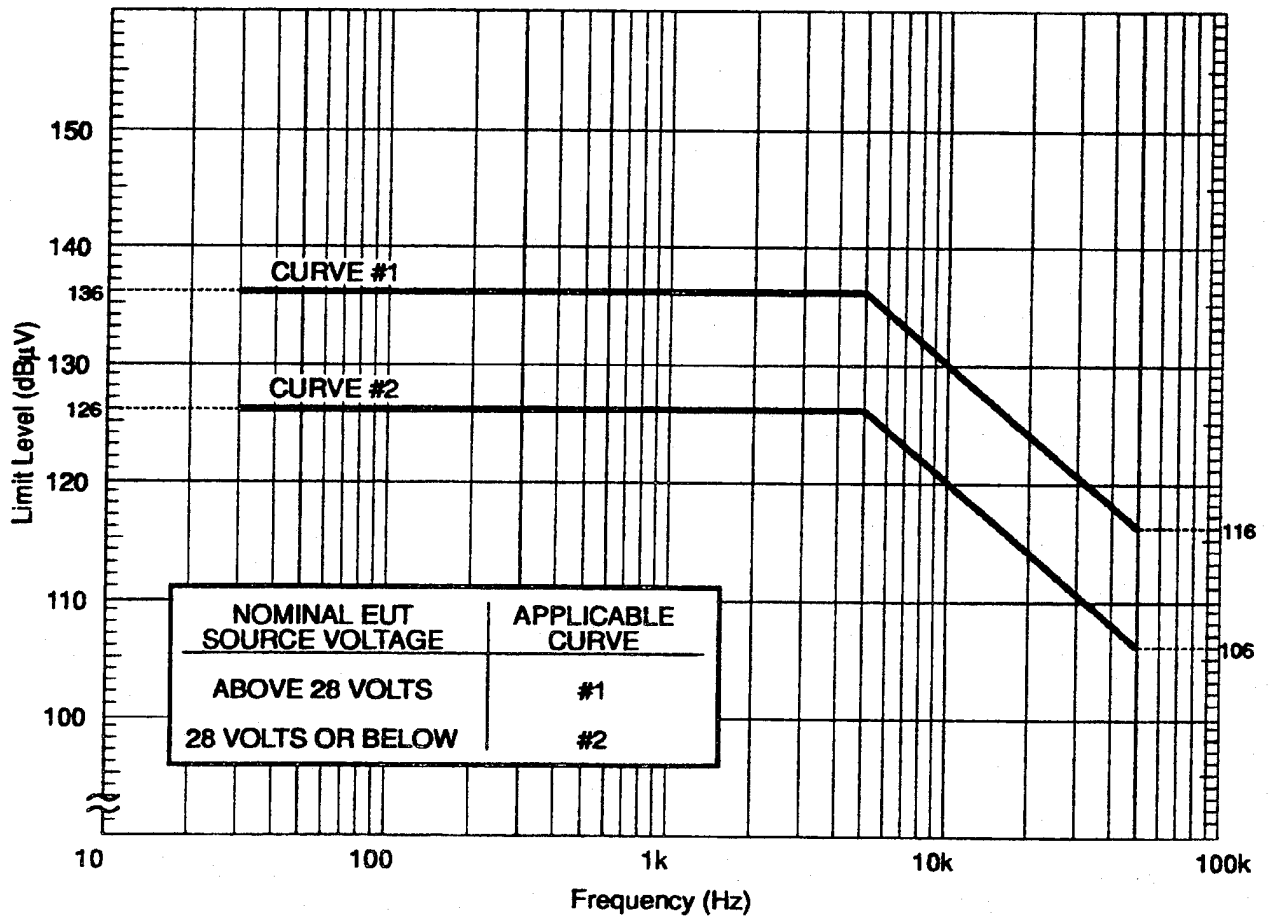

FIGURE CS101-1. CS101 limit (EUT power leads, AC and DC) for all applications.

MIL-STD-461D

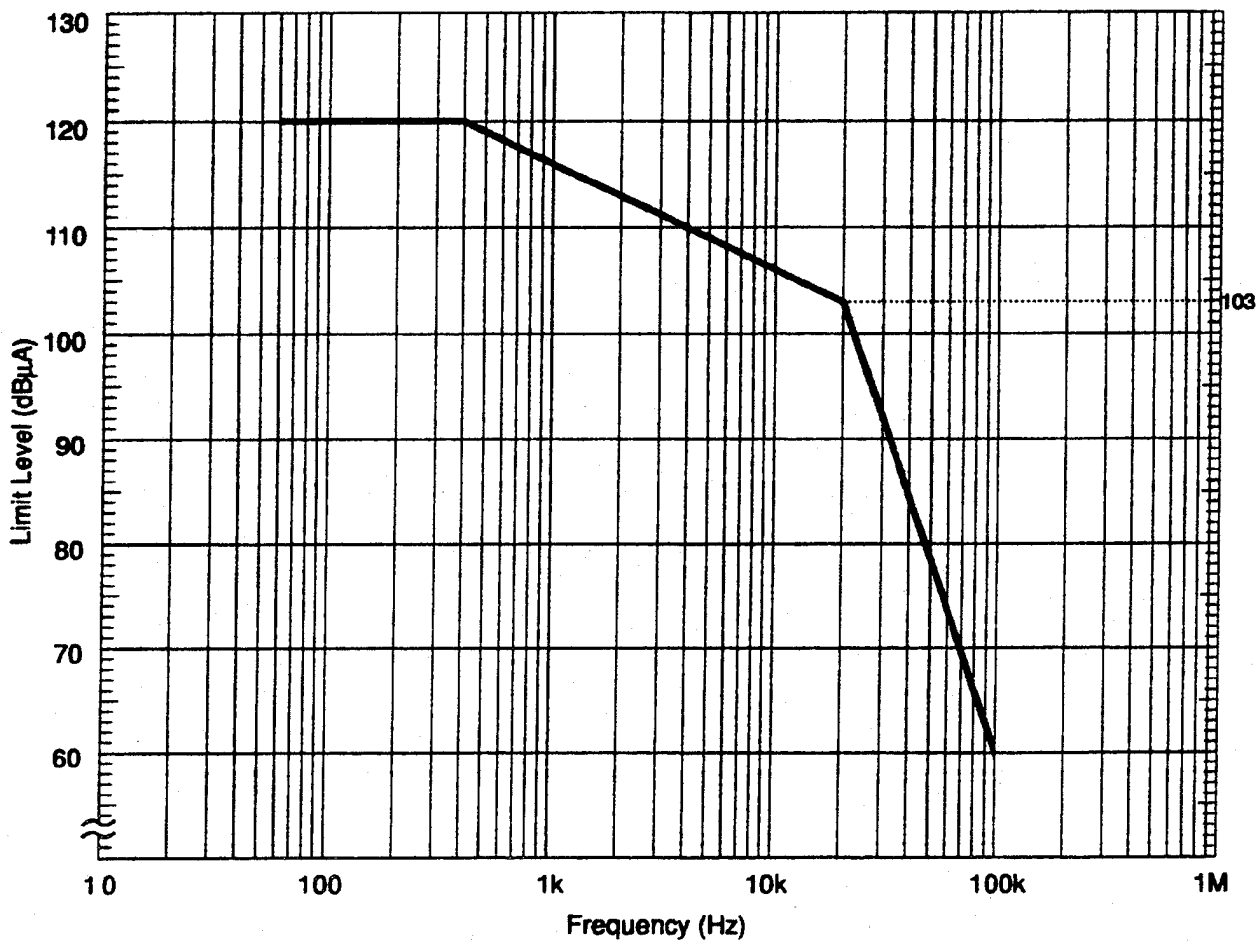

FIGURE CS109-1. CS109 limit for all applications.

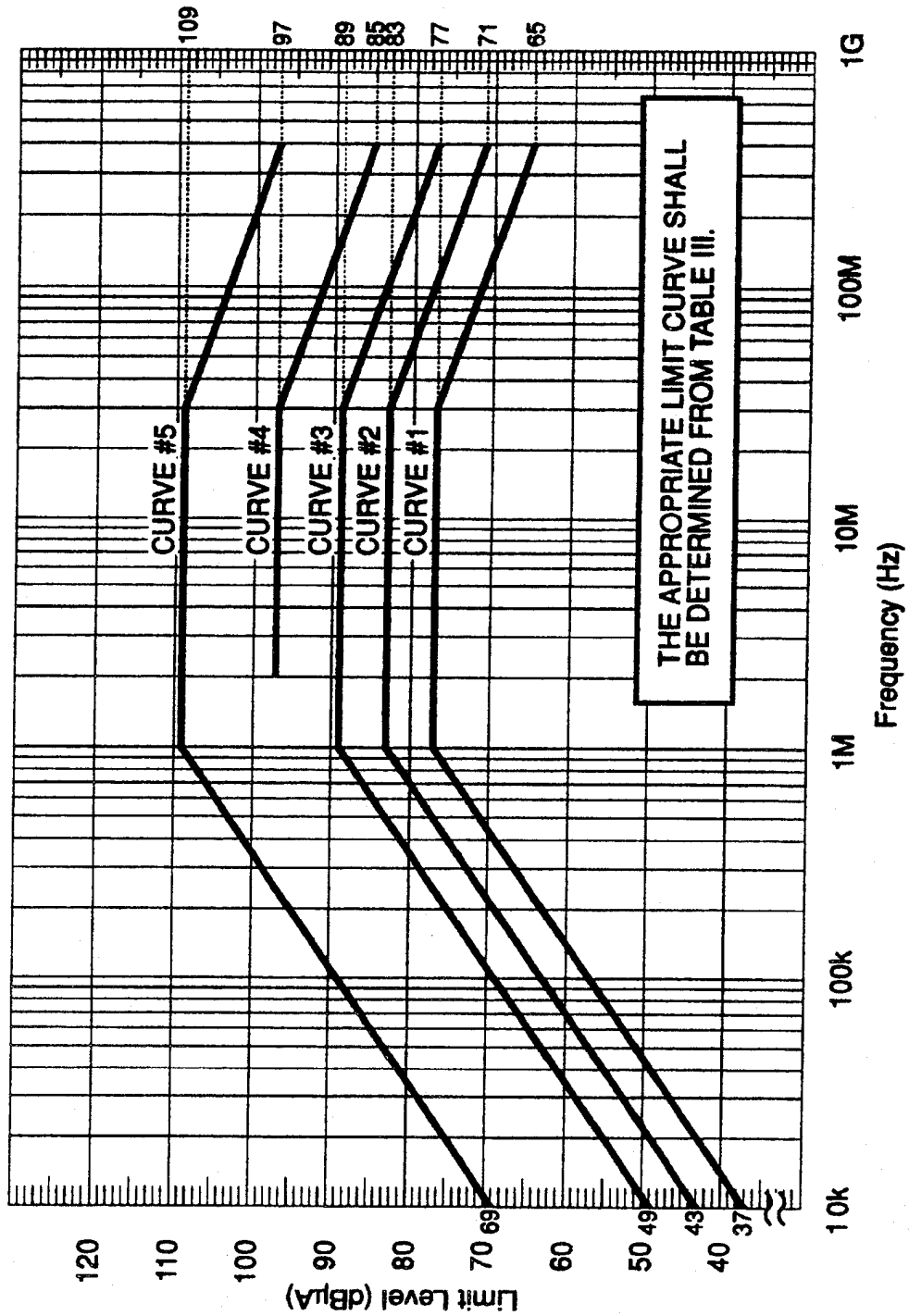

FIGURE CS114-1. CS114 calibration limit for all applications.

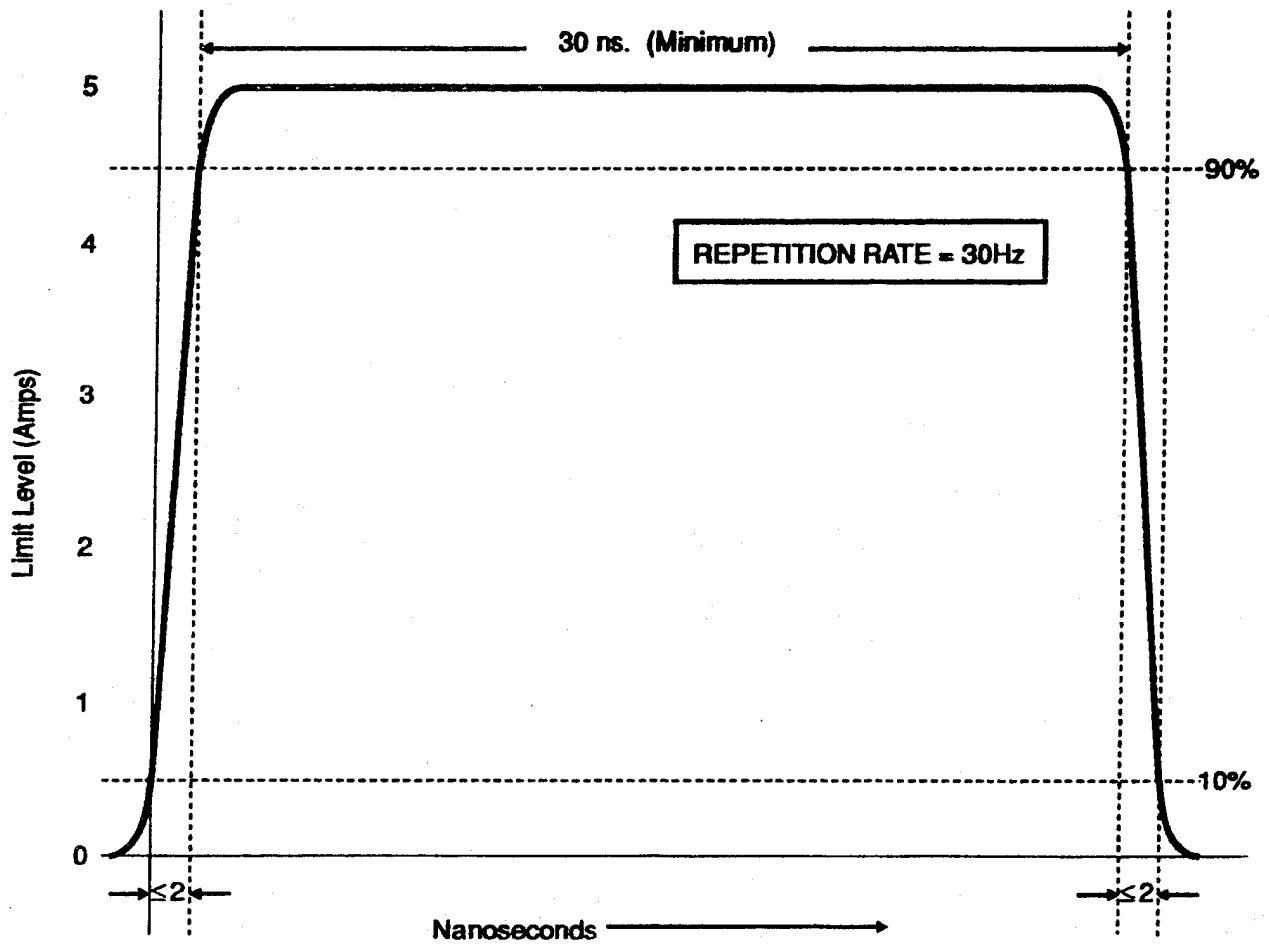
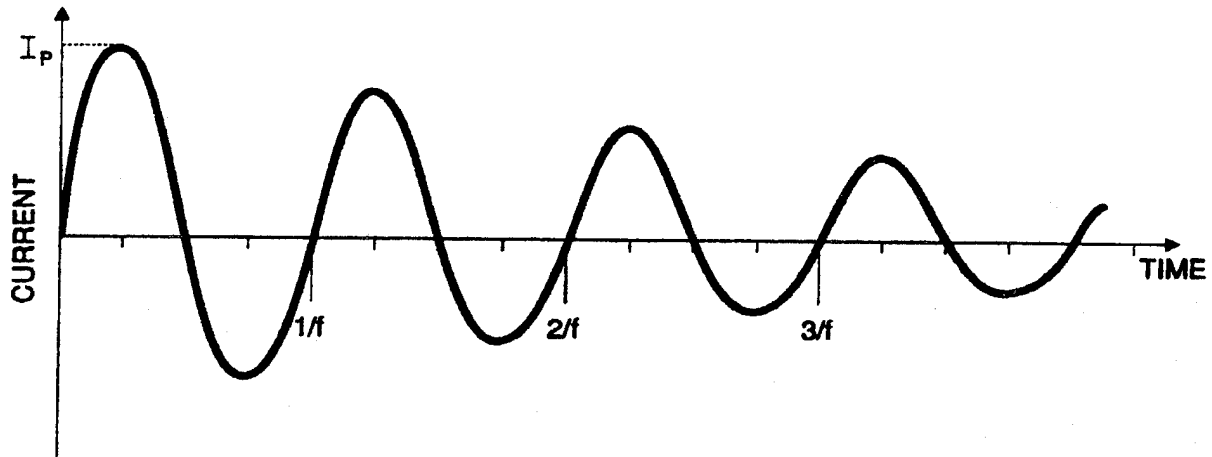

FIGURE CS115-1. CS115 calibrated signal source characteristics for all applications.



NOTES: 1. Normalized waveform: $e^{-(\pi ft)/Q} \sin(2\pi ft)$

Where:

f = Test frequency (Hz)

t = Time (sec)

Q = Damping factor, 15 ± 5

2. Damping factor (Q) shall be determined as follows:

$$Q = \frac{\pi(N - 1)}{\ln(I_p/I_N)}$$

Where:

Q = Damping factor

N = Cycle number (i.e. $N = 2, 3, 4, 5, \dots$)

I_p = Peak current at 1st cycle

I_N = Peak current at N^{th} cycle

\ln = Natural log

3. I_p as per figure CS116-2

FIGURE CS116-1. Typical CS116 damped sinusoidal waveform.

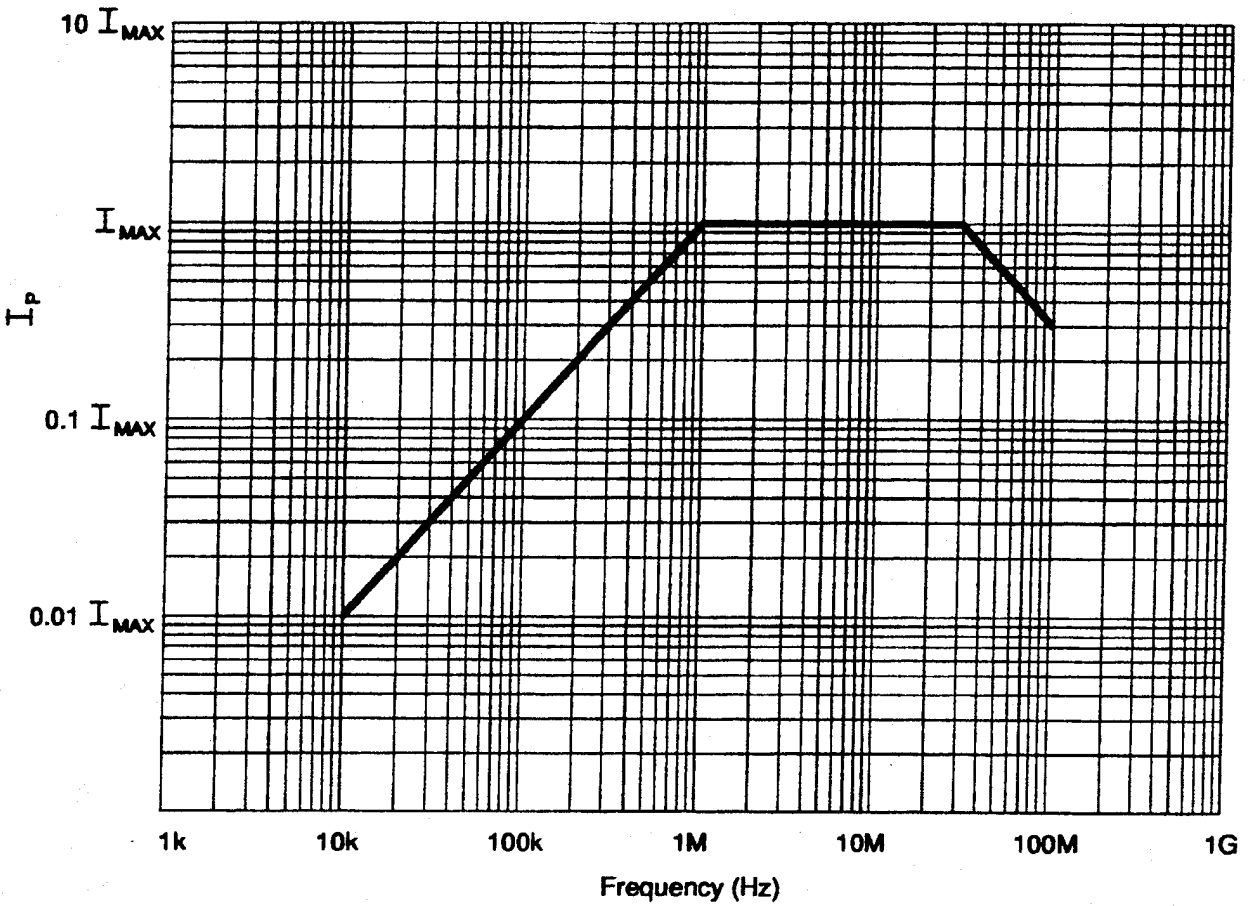

NOTE:

1. For Army and Navy procurements, $I_{MAX} = 10$ amperes
2. For Air Force procurements, $I_{MAX} = 5$ amperes

FIGURE CS116-2. CS116 limit for all applications.

MIL-STD-461D

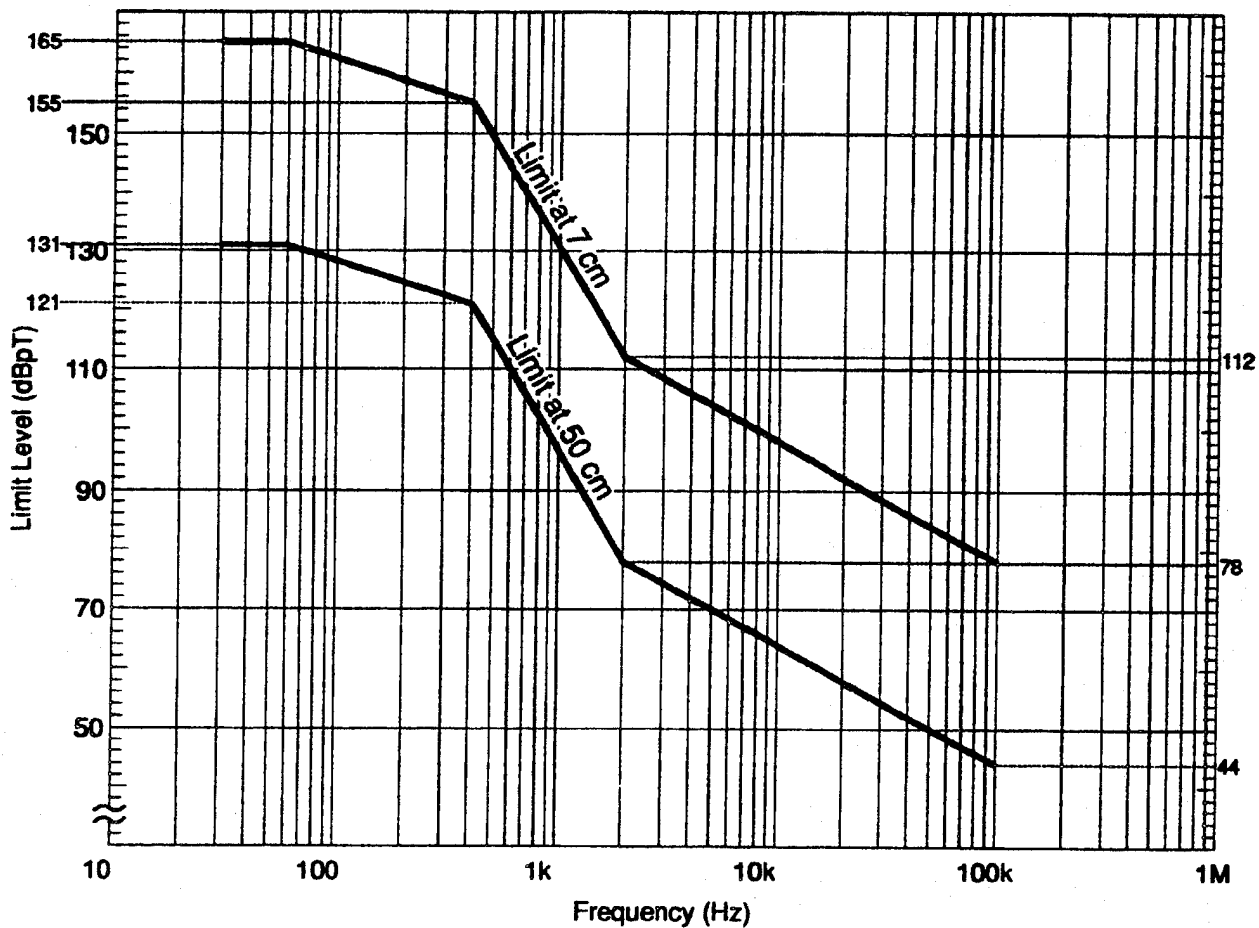

FIGURE RE101-1. RE101 limit (Navy only) for all applications.

MIL-STD-461D

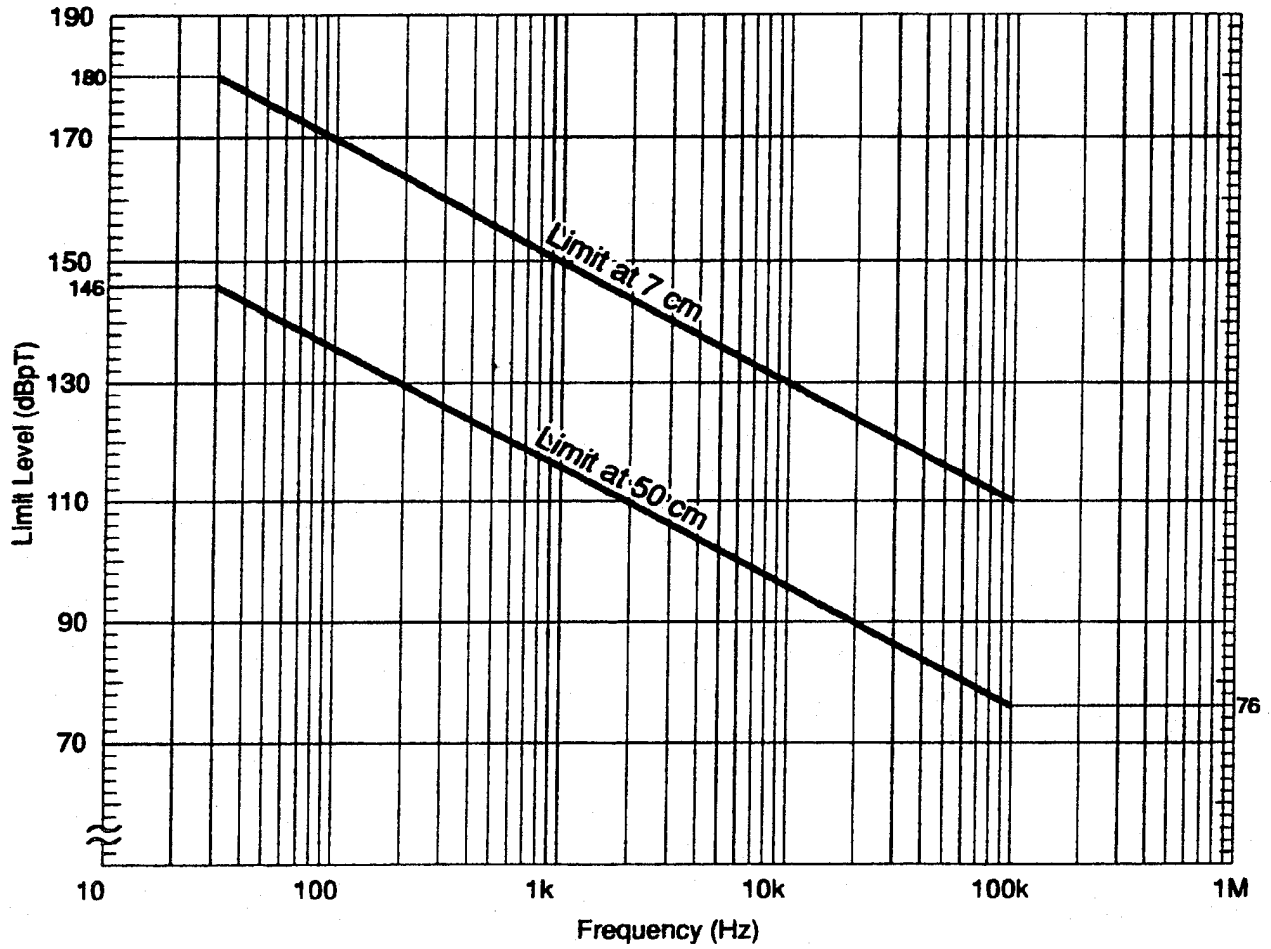

FIGURE RE101-2. RE101 limit (Army only) for all applications.

MIL-STD-461D

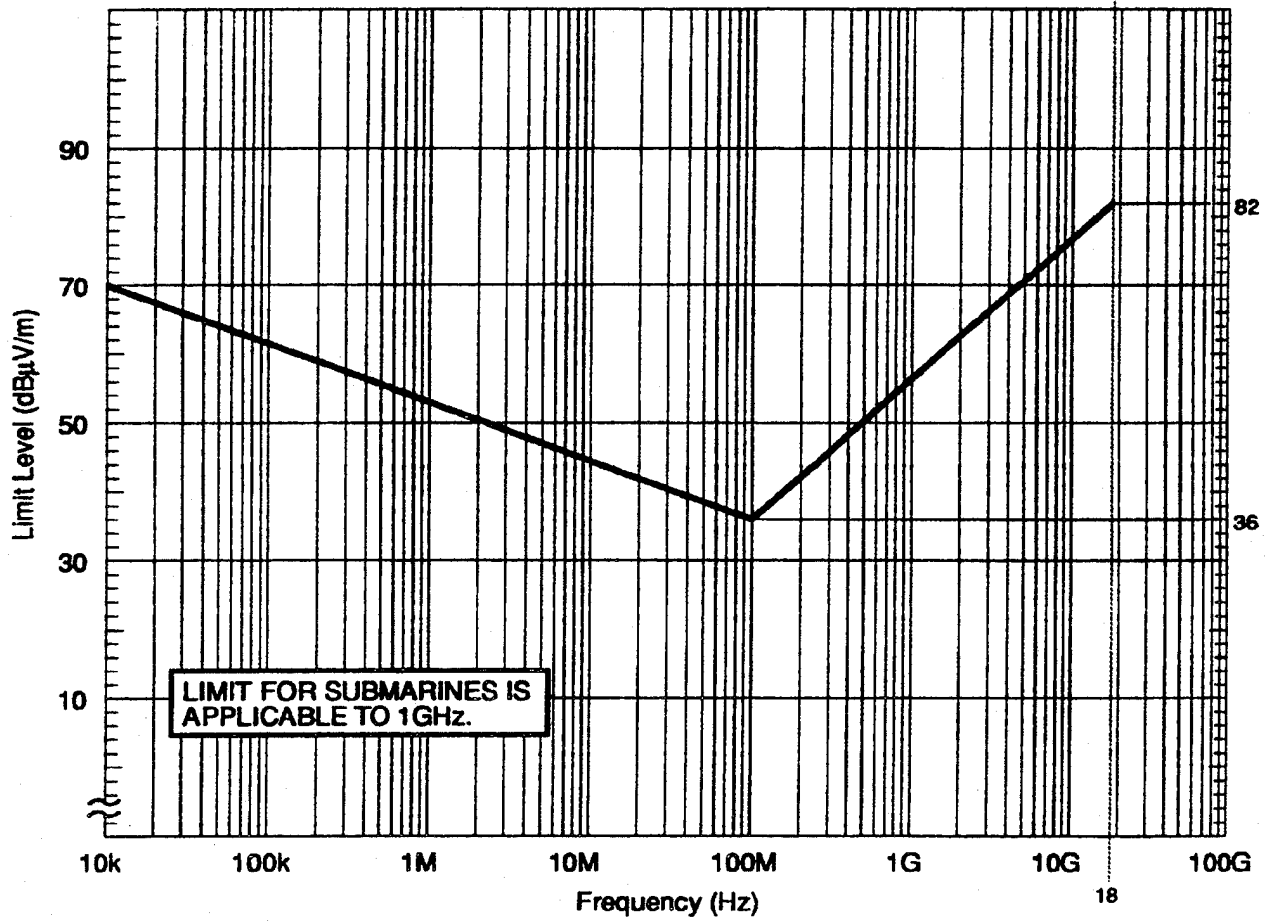

FIGURE RE102-1. RE102 limit for surface ship and submarine applications.

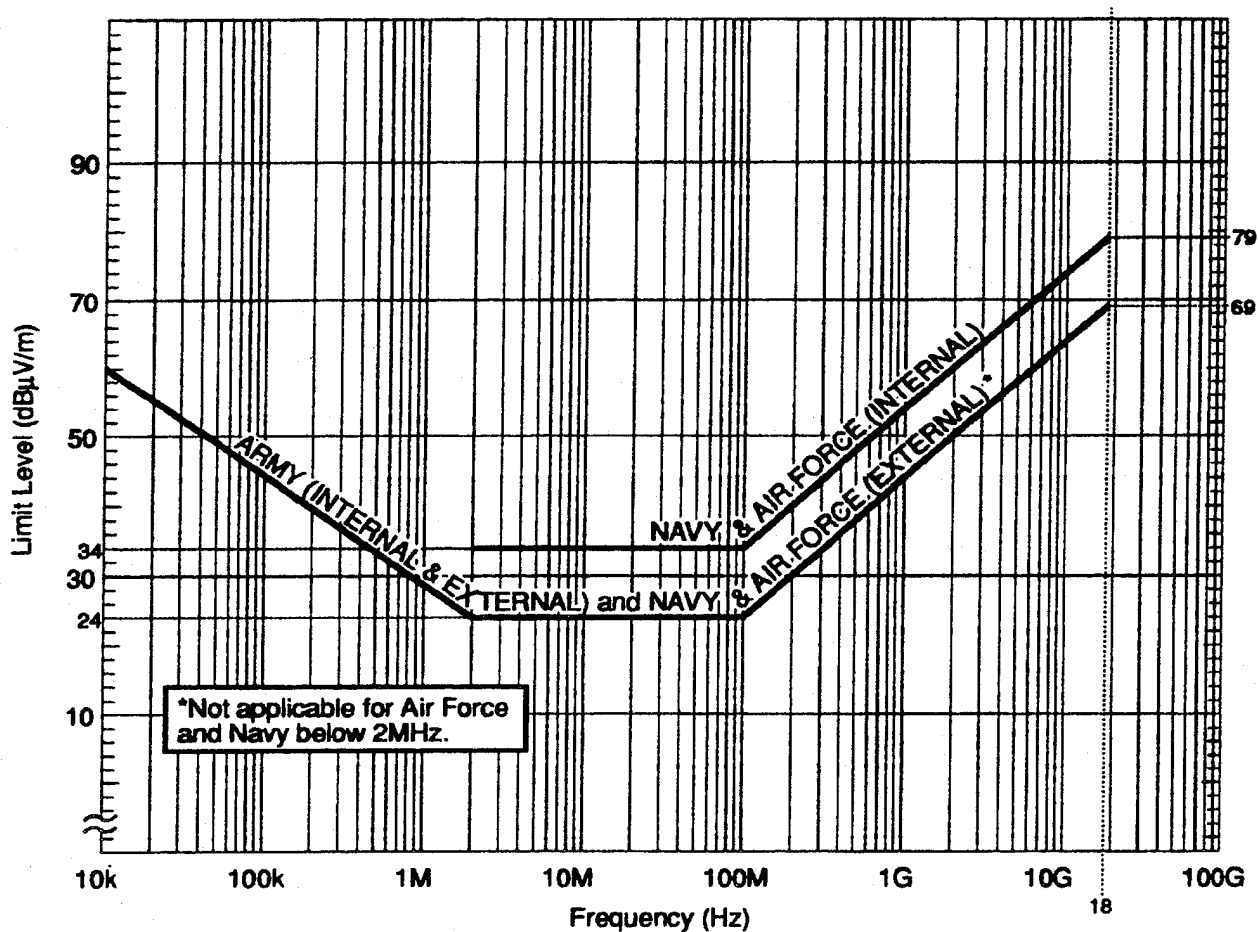

FIGURE RE102-2. RE102 limit for aircraft and space system applications.

MIL-STD-461D

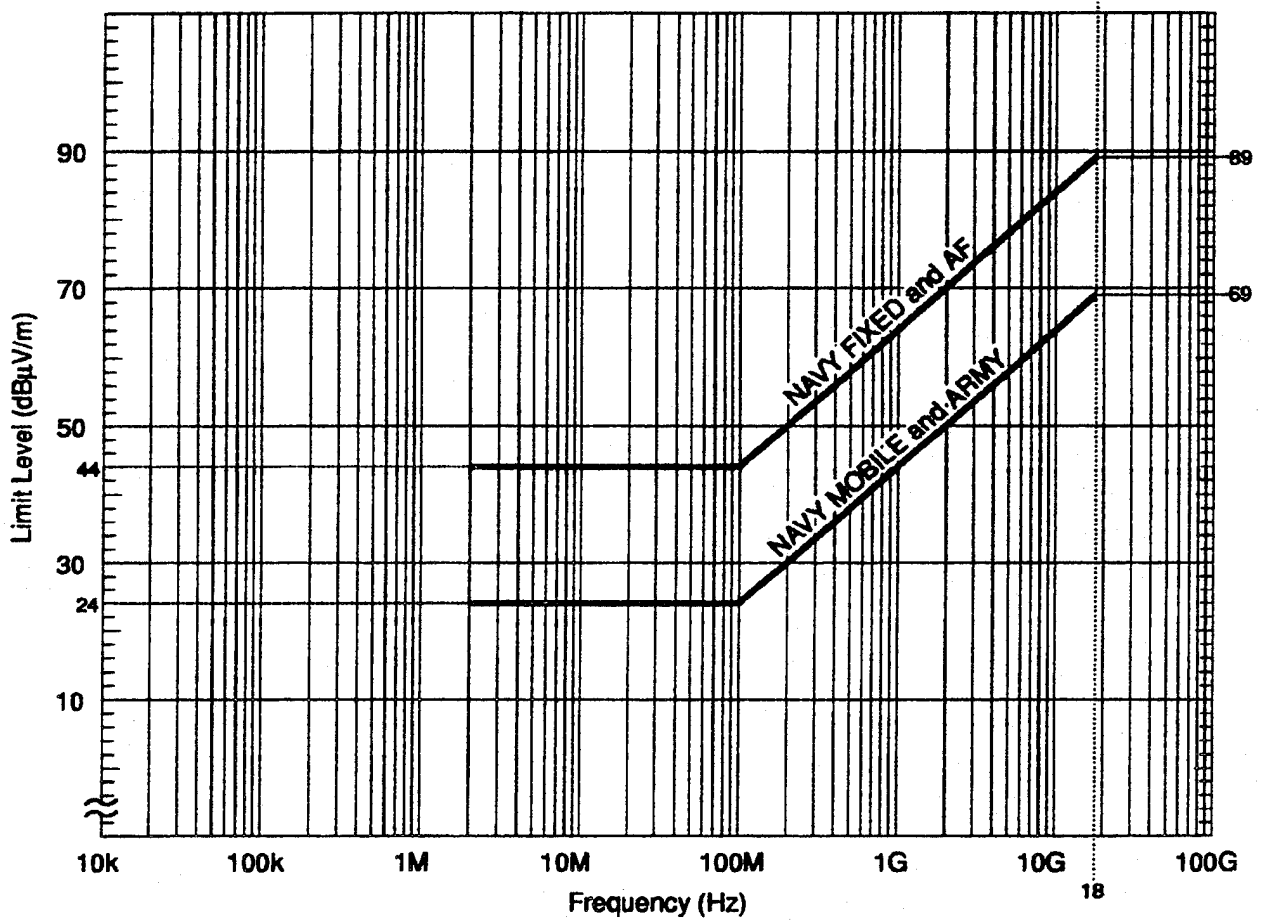

FIGURE RE102-3. RE102 limit for ground applications.

MIL-STD-461D

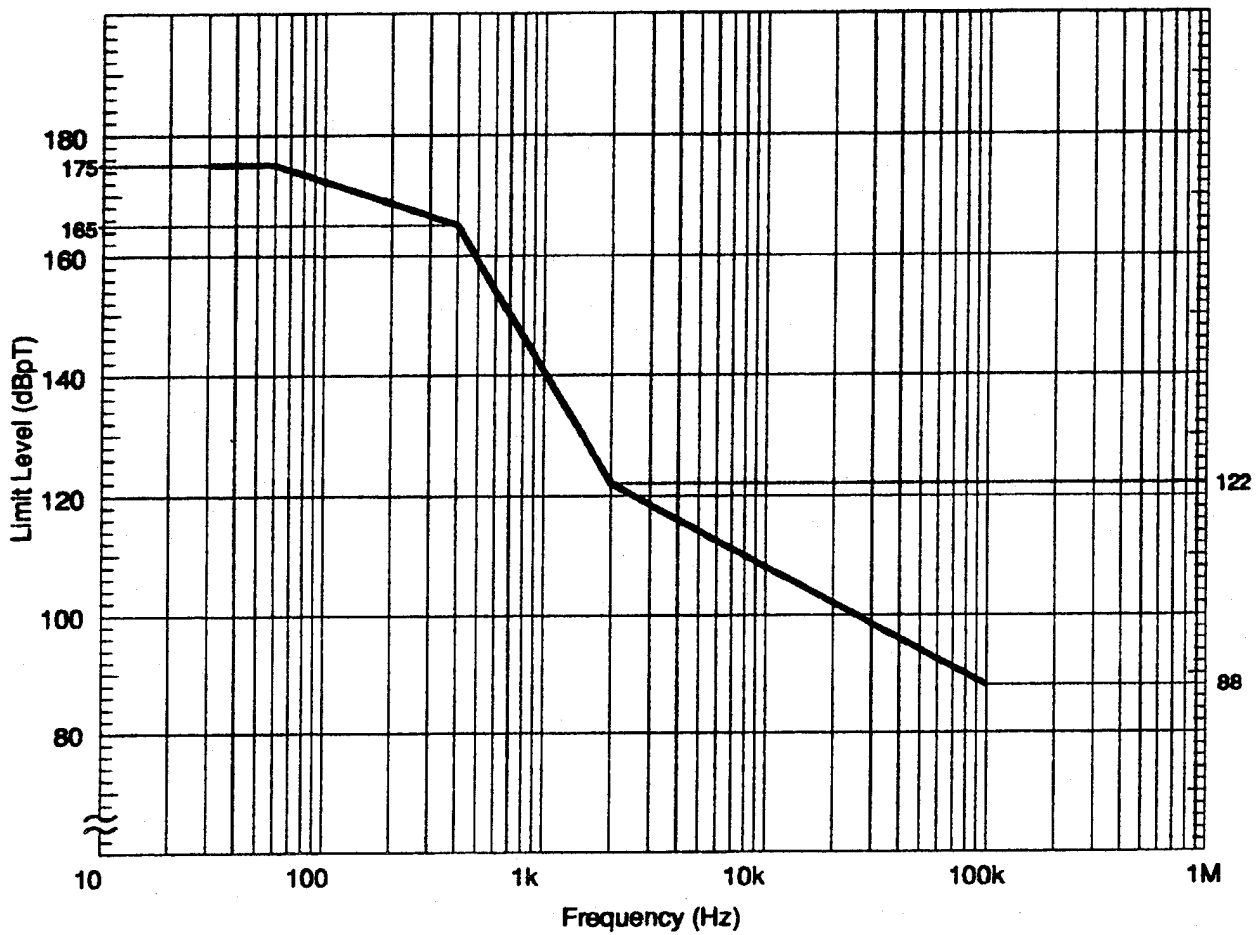

FIGURE RS101-1. RS101 limit (Navy only) for all applications.

MIL-STD-461D

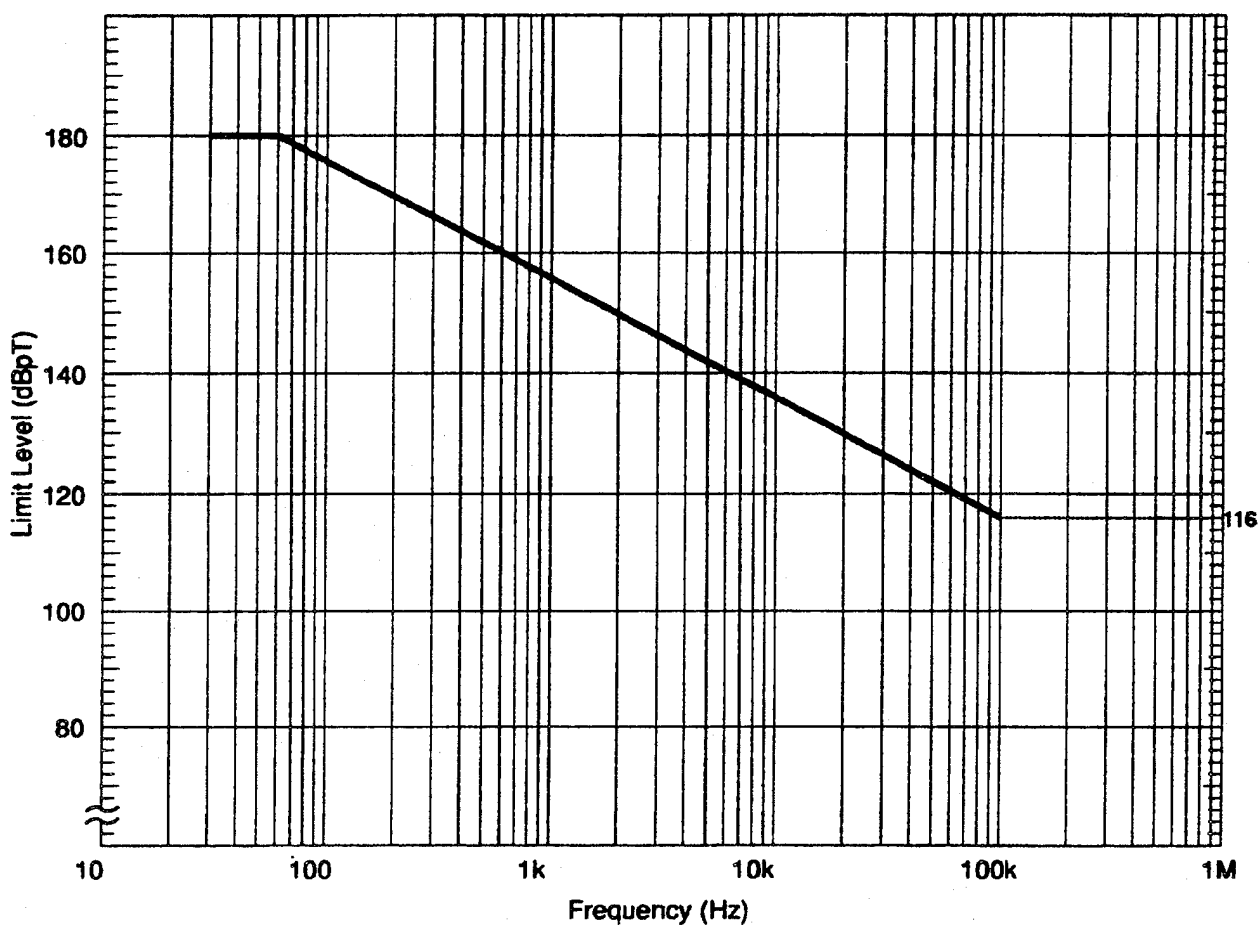

FIGURE RS101-2. RS101 limit (Army only) for all applications.

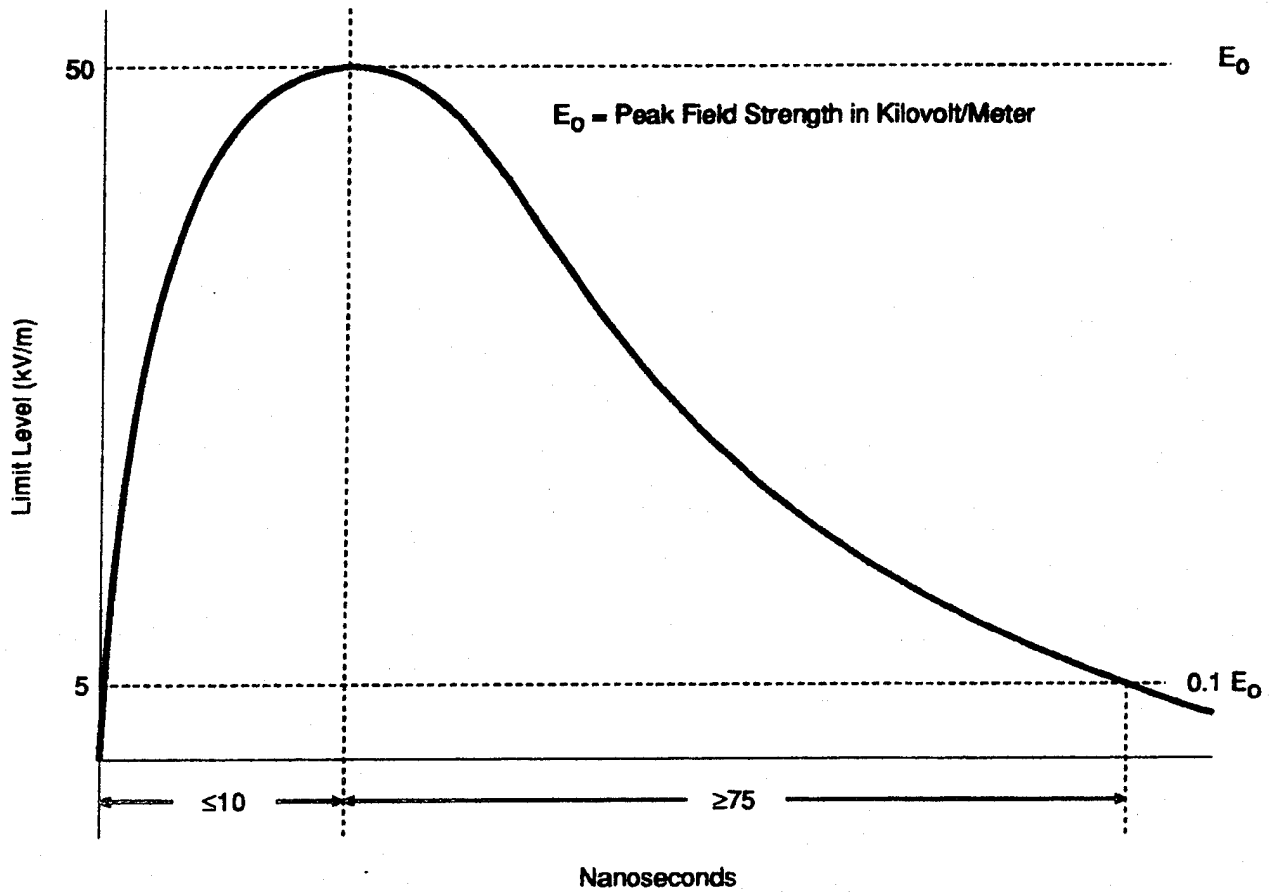

FIGURE RS105-1. RS105 limit for all applications.

MIL-STD-461D

CONCLUDING MATERIAL

Custodians

Army - CR
Air Force - 11

Preparing Activity:
Navy - EC
(Project EMCS - 0133)

Review Activities

Army - MI, AV, TE
Navy - SH, OS, AS, YD, MC, CG, TD
Air Force - 13, 15, 17, 19, 99
NSA

User Activities:

Air Force - 84
Army - AT, ME, CL, CE, MD
DISA
DODECAC
DNA

MIL-STD-461D
APPENDIX

APPENDIX

MIL-STD-461D APPLICATION GUIDE

MIL-STD-461D
APPENDIX
CONTENTS

<u>PARAGRAPH</u>		<u>PAGE</u>
10.	GENERAL	A-4
10.1.	Scope	A-4
10.2	Structure	A-4
20.	APPLICABLE DOCUMENTS	A-5
20.1	Government documents	A-5
20.1.1	Specifications, standards, and handbooks	A-5
20.1.2	Other Government documents, drawings, and publications	A-6
20.2.	Non-Government publications	A-7
30.	DEFINITIONS	A-9
30.1	General	A-9
30.2	Acronyms used in this appendix	A-9
30.3	Below deck	A-9
30.4	External installation	A-10
30.5	Internal installation	A-10
30.6	Metric units	A-10
30.7	Non-developmental item	A-10
30.8	Safety critical	A-10
40.	GENERAL REQUIREMENTS	A-11
40.1	(4.1) General	A-11
40.2	(4.2) Joint procurement	A-12
40.3	(4.3) Filtering (Navy only)	A-12
40.4	(4.4) Self-compatibility	A-13
40.5	(4.5) Non-developmental items (NDI)	A-13
40.5.1	(4.5.1) Commercial off-the-shelf equipment	A-13
40.5.1.1	(4.5.1.1) Selected by contractor	A-15
40.5.1.2	(4.5.1.2) Specified by procuring activity	A-15
40.5.2	(4.5.2) Procurement of equipment or subsystems having met other EMI requirements	A-16
40.6	(4.6) Government furnished equipment (GFE)	A-16
40.7	(4.7) Testing requirements	A-16
40.8	(4.8) Switching transients	A-17
50.	DETAILED REQUIREMENTS	A-20
50.1	(5.1) General	A-20
50.1.1	(5.1.1) Units of frequency domain measurements	A-21
50.2	(5.2) EMI control requirements versus intended installations	A-21
50.3	(5.3) Emission and susceptibility requirements and limits	A-21
50.3.1	(5.3.1) CE101 (Conducted emissions, power leads, 30 Hz to 10 kHz)	A-21
50.3.2	(5.3.2) CE102 (Conducted emissions, power leads, 10 kHz to 10 MHz)	A-23

MIL-STD-461D
APPENDIX
CONTENTS

<u>PARAGRAPH</u>		<u>PAGE</u>
50.3.3	(5.3.3) CE106 (Conducted emissions, antenna terminal, 10 kHz to 40 GHz)	A-25
50.3.4	(5.3.4) CS101 (Conducted susceptibility, power leads, 30 Hz to 50 kHz)	A-27
50.3.5	(5.3.5) CS103 (Conducted susceptibility, antenna port, intermodulation, 15 kHz to 10 GHz)	A-28
50.3.6	(5.3.6) CS104 (Conducted susceptibility, antenna port, rejection of undesired signals, 30 Hz to 20 GHz)	A-29
50.3.7	(5.3.7) CS105 (Conducted susceptibility, antenna port, cross modulation, 30 Hz to 20 GHz)	A-30
50.3.8	(5.3.8) CS109 (Conducted susceptibility, structure current, 60 Hz to 100 kHz)	A-31
50.3.9	(5.3.9) CS114 (Conducted susceptibility, bulk cable injection, 10 kHz to 400 MHz)	A-32
50.3.10	(5.3.10) CS115 (Conducted susceptibility, bulk cable injection, impulse excitation)	A-34
50.3.11	(5.3.11) CS116 (Conducted susceptibility, damped sinusoid transients, cables and power leads, 10 kHz to 100 MHz)	A-35
50.3.12	(5.3.12) RE101 (Radiated emissions, magnetic field, 30 Hz to 50 kHz)	A-36
50.3.13	(5.3.13) RE102 (Radiated emissions, electric field, 10 kHz to 18 GHz)	A-38
50.3.14	(5.3.14) RE103 (Radiated emissions, antenna spurious and harmonic outputs, 10 kHz to 40 GHz)	A-41
50.3.15	(5.3.15) RS101 (Radiated susceptibility, magnetic fields, 30 Hz to 50 kHz)	A-41
50.3.16	(5.3.16) RS103 (Radiated susceptibility, electric field, 10 kHz to 40 GHz)	A-41
50.3.17	(5.3.17) RS105 (Radiated susceptibility, transient, electromagnetic field)	A-43

MIL-STD-461D
APPENDIX

10. GENERAL

10.1. Scope. This appendix provides background information for each requirement in the main body of the standard. This information includes rationale for requirements, guidance in applying the requirements and lessons learned from platform experience. This information should help users understand the intent behind the requirements and should aid the procuring activity in tailoring requirements as necessary for particular applications. This handbook is provided for guidance purposes and, as such, should not be interpreted as providing contractual requirements.

10.2 Structure. This appendix follows the same general format as the main body of the standard. A "DISCUSSION" paragraph is provided for each requirement contained in the standard. Main body paragraph numbers corresponding to each requirement are included in parentheses.

MIL-STD-461D
APPENDIX

20. APPLICABLE DOCUMENTS

20.1 Government documents.

20.1.1 Specifications, standards, and handbooks. The following specifications, standards, and handbooks form a part of this document to the extent specified herein. Unless otherwise specified, the issue of these documents are those listed in the issue of the Department of Defense Index of Specifications and Standards (DODISS) and supplement thereto, cited in the solicitation.

SPECIFICATIONS

MILITARY

- MIL-E-6051 - Electromagnetic Compatibility Requirements, Systems

STANDARDS

MILITARY

- MIL-STD-462 - Measurement of Electromagnetic Interference Characteristics
- MIL-STD-704 - Aircraft Electric Power Characteristics
- MIL-STD-1275 - Characteristics of 28 Volt DC Electrical Systems in Military Vehicles
- MIL-STD-1377 - Effectiveness of Cable, Connector and Weapon Enclosure Shielding and Filters in Precluding Hazards of Electromagnetic Radiation to Ordnance, Measurement of
- MIL-STD-1385 (NAVY) - Preclusion of Ordnance Hazards in Electromagnetic Fields, General Requirements for
- MIL-STD-1399 (NAVY) Section 300 - Interface Standard for Ship Systems, Section 300, Electric Power, Alternating Current

MIL-STD-461D
APPENDIX

- MIL-STD-1512 - Electroexplosive Subsystems,
(USAF) Electrically Initiated, Test
Methods and Design Requirements
- MIL-STD-1539 - Electric Power, Direct Current,
(USAF) Space Vehicle Design Requirements
- MIL-STD-1541 - Electromagnetic Compatibility
(USAF) Requirements for Space Systems
- MIL-STD-1542 - Electromagnetic Compatibility
(USAF) (EMC) and Grounding Requirements
for Space Systems Facilities
- MIL-STD-1757 - Lightning Qualification Test
Techniques for Aerospace Vehicles
and Hardware
- MIL-STD-1795 - Lightning Protection of Aerospace
Vehicles and Hardware
- MIL-STD-1818 - Electromagnetic Effects
Requirements for Systems

HANDBOOKS

MILITARY

- MIL-HDBK-235 - Electromagnetic (Radiated)
Considerations for Design and
Procurement of Electrical and
Electronic Equipment
- MIL-HDBK-237 - Electromagnetic Compatibility
Management Guide for Platforms,
Systems and Equipment
- MIL-HDBK-241 - Design Guide for EMI Reduction in
Power Supplies
- MIL-HDBK-253 - Guidance for the Design and Test
of Systems Protected Against the
Effects of Electromagnetic Energy

(Unless otherwise indicated, copies of federal and military specifications, standards, and handbooks are available from the Naval Publications and Forms Center, (ATTN: NPODS, 5801 Tabor Avenue, Philadelphia PA 19120-5099.))

20.1.2 Other Government documents, drawings, and publications. The following other Government documents,

MIL-STD-461D
APPENDIX

drawings, and publications form a part of this standard to the extent specified herein. Unless otherwise specified, the issues are those cited in the solicitation.

PUBLICATIONS

AIR FORCE SYSTEMS COMMAND (AFSC)

AFSC DH 1-4 - Air Force Systems Command Design Handbook, EMC

FEDERAL COMMUNICATIONS COMMISSION

CFR Title 47 - Parts 2, 15, and 18

DEPARTMENT OF DEFENSE (DOD)

DODISS - Department of Defense Index of Specifications and Standards

DOD 5000.37-M - DOD Non Developmental Items Acquisition Manual

US ARMY AMC MATERIEL READINESS SUPPORT ACTIVITY

AMC Pamphlet 706-235 - Hardening Weapon Systems Against RF Energy

AMC Pamphlet 706-410 - Engineering Design Handbook, EMC

US ARMY AVIATION SYSTEMS COMMAND

ADS-37 - Electromagnetic Environmental Effects (E³) Management, Design and Test Requirements

NAVAL SEA SYSTEMS COMMAND (NAVSEA)

NAVSEA OD 30393 - Design Principles and Practices for Controlling Hazards of Electromagnetic Radiation to Ordnance

(Copies of publications required by contractors in connection with specific acquisition functions should be obtained from the contracting activity or as directed by the contracting officer.)

20.2. Non-Government publications. The following documents form a part of this document to the extent specified herein.

MIL-STD-461D
APPENDIX

Unless otherwise specified, the issues of the documents which are DOD adopted are those listed in the issue of the DODISS cited in the solicitation. Unless otherwise specified, the issues of documents not listed in the DODISS are the issues of the documents cited in the solicitation.

AMERICAN NATIONAL STANDARDS INSTITUTE (ANSI)

ANSI C63.12 - American National Standard for
Electromagnetic Compatibility
Limits - Recommended Practice

ANSI C63.14 - Standard Dictionary for
Technologies of Electromagnetic
Compatibility (EMC),
Electromagnetic Pulse (EMP), and
Electrostatic Discharge (ESD)

ANSI/IEEE 268 - Metric Practice. (DOD adopted)

(Application for copies should be addressed to the IEEE
Service Center, 445 Hoes Lane, P.O. Box 1331, Piscataway, NJ
08855-1331.)

AMERICAN SOCIETY FOR TESTING AND MATERIALS (ASTM)

ASTM E 380 - Standard for Metric Practice. (DOD
adopted)

(Application for copies should be addressed to the American
Society for Testing and Materials, 1916 Race Street,
Philadelphia, PA 19103-1187.)

RADIO TECHNICAL COMMISSION FOR AERONAUTICS

DO-160 - Environmental Conditions and Test
Conditions for Airborne Equipment

(Applications for copies should be addressed to Radio
Technical Commission for Aeronautics Secretariat, One McPherson
Square, Suite 500, 1425 K Street, NW, Washington DC 20005.)

(Non-government standards are generally available for
reference from libraries. They are also distributed among non-
government standards bodies and using Federal agencies.)

MIL-STD-461D
APPENDIX

30. DEFINITIONS

30.1 General. The terms used in this appendix are defined in ANSI C63.14. In addition, the following definitions are applicable for the purpose of this appendix.

30.2 Acronyms used in this appendix.

- a. ASW - Anti-submarine Warfare
- b. EMC - Electromagnetic Compatibility
- c. EME - Electromagnetic Environment
- d. EMI - Electromagnetic Interference
- e. EMICP - Electromagnetic Interference Control Procedures
- f. EMITP - Electromagnetic Interference Test Procedures
- g. EMITR - Electromagnetic Interference Test Report
- h. EMP - Electromagnetic Pulse
- i. EUT - Equipment Under Test
- j. GFE - Government Furnished Equipment
- k. LISN - Line Impedance Stabilization Network
- l. NDI - Non-Developmental Item
- m. NOE - Nap-of-the-earth
- n. RF - Radio Frequency
- o. RMS - Root Mean Square
- p. VFR - Visual Flight Rules

30.3 Below deck. An area on ships which is surrounded by a metallic structure, or an area which provides significant attenuation to electromagnetic radiation, such as the metal hull or superstructure of a surface ship, the hull of a submarine and the screened rooms in non-metallic ships.

MIL-STD-461D
APPENDIX

30.4 External installation. An equipment location on a platform which is exposed to the external electromagnetic environment, such as an aircraft cockpit which does not use electrically conductive treatments on the canopy or windscreen.

30.5 Internal installation. An equipment location on a platform which is totally inside an electrically conductive structure, such as a typical avionics bay in an aluminum skin aircraft.

30.6 Metric units. Metric units are a system of basic measures which are defined by the International System of Units based on "Le System International d'Unites (SI)", of the International Bureau of Weights and Measures. These units are described in ASTM E 380 and ANSI/IEEE 268.

30.7 Non-developmental item. Non-developmental item is a broad, generic term that covers material available from a wide variety of sources with little or no development effort required by the Government.

30.8 Safety critical. A category of subsystems and equipment whose degraded performance could result in loss of life or loss of vehicle or platform.

MIL-STD-461D
APPENDIX

40. GENERAL REQUIREMENTS

40.1 (4.1) General. Electronic, electrical, and electromechanical equipment and subsystems shall comply with the applicable requirements in 4.2 through 4.8. The requirements are in addition to the applicable emission and susceptibility requirements defined in other portions of this standard.

DISCUSSION: The requirements in this paragraph are universally applicable to all subsystems and equipment. Separate emission and susceptibility requirements which are structured to address specific concerns with various classes of subsystems and equipment are contained in other portions of this standard.

This document is concerned only with specifying technical design requirements for controlling electromagnetic interference (EMI) emissions and susceptibility at the subsystem-level and equipment-level. The requirements in this document are not intended to be directly applied to subassemblies of equipment such as modules or circuit cards. The basic concepts can be implemented at the subassembly level; however, significant tailoring needs to be accomplished for the particular application. The requirements included herein are intended to be used as a baseline. Placement of the limits is based on demonstrated performance typically required for use on existing platforms in order to achieve electromagnetic compatibility (EMC). System-level requirements dealing with integration of subsystems and equipment are contained in documents such as MIL-E-6051, MIL-STD-1818, MIL-STD-1541 and MIL-STD-1542. The procuring activity and system contractors should review the requirements contained herein for possible tailoring based on system design and expected operational environments.

Guidance and techniques which are helpful in designing to meet the requirements of this standard are contained in MIL-HDBK-241, MIL-HDBK-253, AFSC DH 1-4, and AMC Pamphlet 706-410. MIL-HDBK-237 provides guidance for management of EMC efforts. ADS-37 provides additional guidance for Army equipment located or operated on fixed-wing aircraft and helicopters. MIL-HDBK-235 provides information on land, air, and sea based RF emitters, both hostile and friendly, which contribute to the overall electromagnetic environment. MIL-STD-1818 specifies the total electromagnetic environment (external RF, EMP, and lightning) for complete systems for Air Force applications.

An area related to EMI control is design requirements of electroexplosive subsystems and electroexplosive devices. MIL-STD-1512 specifies requirements for Air Force applications. MIL-STD-1385 specifies ordnance design requirements for the NAVY

MIL-STD-461D
APPENDIX

with OD 30393 providing design guidance. MIL-STD-1377 contains techniques for evaluating the effectiveness of cable, connector, and weapon enclosure shielding.

Another related area is lightning requirements. MIL-STD-1795 specifies design requirements for protecting aerospace vehicles and hardware from the effects of lightning. MIL-STD-1757 provides test techniques for evaluating aerospace vehicles and hardware to the lightning threat.

40.2 (4.2) Joint procurement. Equipment or subsystems procured by one DOD activity for multi-agency use shall comply with the requirements of the user agencies.

DISCUSSION: When the government procures equipment that will be used by more than one service or agency, a particular activity is assigned responsibility for overall procurement. The responsible activity must address the concerns of all the users. Conflicts may exist among the parties concerned. Also, imposition of more severe design requirements by one party may adversely affect other performance characteristics required by the second party. For example, severe radiated susceptibility levels on an electro-optical sensor may require aperture protection measures which compromise sensitivity. It is important that these issues be resolved to the satisfaction of all parties and that all genuine requirements be included.

40.3 (4.3) Filtering (Navy only). The use of line-to-ground filters for EMI control shall be minimized. Such filters establish low impedance paths for structure (common-mode) currents through the ground plane and can be a major cause of interference in systems, platforms, or installations because the currents can couple into other equipment using the same ground plane. If such a filter must be employed, the line-to-ground capacitance for each line shall not exceed 0.1 microfarads (μF) for 60 Hertz (Hz) equipment or 0.02 μF for 400 Hz equipment. For submarine DC-powered equipment and aircraft DC-powered equipment, the filter capacitance from each line-to-ground at the user interface shall not exceed 0.075 $\mu\text{F}/\text{kW}$ of connected load. For loads less than 0.5 kW, the filter capacitance shall not exceed 0.03 μF . The filtering employed shall be fully described in the equipment or subsystem technical manual and the Electromagnetic Interference Control Procedures (EMICP) (See 6.3).

DISCUSSION: The power systems for Navy ships and submarines are ungrounded. The primary AC power, both 60 Hz and 400 Hz are three-phase, ungrounded, delta configuration systems. The primary DC power for submarines is a two-wire ungrounded system. The capacitance-to-ground of power line filters provides a path for conducting current into the hull structure. The Navy uses very sensitive low frequency radio and sonar receivers. At low

MIL-STD-461D
APPENDIX

frequencies, currents flowing through the installation structure and across surfaces of electronic enclosures will penetrate to the inside of the enclosure. The magnetic fields created by these currents can couple into critical circuits and degrade performance. At higher frequencies (greater than 100 kHz), the combination of power line filter capacitance-to-ground limitation, skin effect of equipment enclosures and reduced harmonic currents tend to minimize the problems associated with structure currents.

40.4 (4.4) Self-compatibility. The operational performance of an equipment or subsystem shall not be degraded, nor shall it malfunction when all of the units or devices in the equipment or subsystem are operating together at their designed levels of efficiency or their design capability.

DISCUSSION: The EMI controls imposed by this standard apply to subsystem-level hardware with the purpose of insuring compatibility when various subsystems are integrated into a system platform. In a parallel sense, a subsystem can be considered to be an integration of various assemblies, circuit cards, and electronics boxes. While specific requirements could be imposed to control the interference characteristics of these individual items, this standard is concerned only with the overall performance characteristics of the subsystem after integration. Therefore, the subsystem itself must exhibit compatibility among its various component parts and assemblies.

40.5 (4.5) Non-developmental items (NDI). In accordance with the guidance provided in DOD 5000.37-M, the requirements of this standard shall be met when applicable and warranted by the intended installation and platform requirements.

DISCUSSION: NDI refers to any equipment which is already developed and ready for use including both commercial and military items. DOD 5000.37-M provides guidance on EMC issues relating to the use of NDI. DOD 5000.37-M states concerns with proper operation in the mission environment and the need for compatibility with existing operational equipment. The document includes cautions that acceptance in the commercial marketplace does not mean that EMC requirements are met, that modifications to correct EMC problems can be costly and time consuming, and that EMC problems can be potentially hazardous. DOD 5000.37-M states that quantitative EMC requirements should be developed and that valid data needs to be gathered during a market investigation for performance of analysis to determine the suitability of the NDI. Testing may be required if there is insufficient data. An EMC board is recommended to provide alternatives to decision makers.

40.5.1 (4.5.1) Commercial off-the-shelf equipment.

MIL-STD-461D

APPENDIX

DISCUSSION: The use of commercial off-the-shelf equipment presents a dilemma between the need for EMI control with appropriate design measures implemented and the desire to take advantage of existing designs which may exhibit undesirable EMI characteristics. Paragraphs 4.5.1.1 and 4.5.1.2 address the specific requirements for the two separate cases of contractor selection versus procuring activity specification of commercial equipment.

For some applications of commercially developed products, such as commercial transport aircraft, EMI requirements similar to those in this standard are usually imposed on equipment. Most commercial aircraft equipment is required to meet the EMI requirements in RTCA DO-160 or an equivalent contractor in-house document. Revisions to RTCA DO-160 in 1989 and planned changes in the early 1990s are making the document more compatible with this standard. Equipment qualified to RTCA DO-160 is often suitable for military aircraft applications.

EMI requirements on most commercial equipment are more varied and sometimes nonexistent. The Federal Communication Commission (FCC) is responsible for regulating "Non-Licensed Radio Frequency Devices" in the commercial and residential environment to control interference to radio reception. Requirements are imposed in FCC Rules, Parts 2, 15, and 18. The FCC does not control susceptibility (referred to as immunity in the commercial community) characteristics of equipment. The most widely applied requirement is Part 15 which requires that any "digital device" comply with the following conducted and radiated emission limits for commercial environments (Class A) and residential environments (Class B).

CONDUCTED EMISSIONS

FREQUENCY (MHz)	CLASS A (dB μ V)	CLASS B (dB μ V)
0.45 - 1.705	60	48
1.705 - 30	70	48

RADIATED EMISSIONS

FREQUENCY (MHz)	CLASS A (dB μ V/m at 10 meters)	CLASS B (dB μ V/m at 3 meters)
30 - 88	39	40
88 - 216	44	44
216 - 960	46	46
above 960	50	54

MIL-STD-461D
APPENDIX

These requirements are typically less stringent than military requirements of a similar type. Also, there is difficulty in comparing levels between commercial and military testing due to differences in measurement distances, different types of antennas, and near-field conditions.

The commercial community is moving toward immunity standards. The basis for immunity control is given in ANSI C63.12. There is also activity in the international area. The European Community is imposing mandatory standards and the International Electrotechnic Commission is working on standards. A comparison of various proposed limits are as listed below:

RF Radiated Immunity:	1, 3, or 10 V/m 0.15 to 1,000 MHz
RF Conducted Immunity:	1 to 7 Vrms 10 kHz to 400 MHz
Transient Immunity:	600 V 0.01 μ s/1 μ s, 50 Ohm source

40.5.1.1 (4.5.1.1) Selected by contractor. When it is demonstrated that a commercial item selected by the contractor is responsible for equipment or subsystems failing to meet the contractual EMI requirements, either the commercial item shall be modified or replaced or interference suppression measures shall be employed, so that the equipment or subsystems meet the contractual EMI requirements.

DISCUSSION: The contractor retains responsibility for complying with EMI requirements regardless of the contractor's choice of commercial off-the-shelf items. The contractor can treat selected commercial items as necessary provided required performance is demonstrated.

40.5.1.2 (4.5.1.2) Specified by procuring activity. When it is demonstrated by the contractor that a commercial item specified by the procuring activity for use in an equipment or subsystem is responsible for failure of the equipment or subsystem to meet its contractual EMI requirements, the data indicating such failure shall be included in the EMITR (See 6.3). No modification or replacement shall be made unless authorized by the procuring activity.

DISCUSSION: The procuring activity retains responsibility for EMI characteristics of commercial items which the procuring activity specifies to be used as part of a subsystem or equipment. The procuring activity will typically study trade-offs between the potential of system-level problems and the

MIL-STD-461D
APPENDIX

benefits of retaining unmodified commercial equipment. The procuring activity needs to provide specific contractual direction when modifications are considered to be necessary.

40.5.2 (4.5.2) Procurement of equipment or subsystems having met other EMI requirements. Procurement of equipment and subsystems electrically and mechanically identical to those previously procured by activities of DOD or other Federal agencies, or their contractors, shall meet the EMI requirements and associated limits, as applicable in the earlier procurement, unless otherwise specified by the Command or agency concerned.

DISCUSSION: In general, the government expects configuration controls to be exercised in the manufacturing process of equipment and subsystems to ensure that produced items continue to meet the particular EMI requirements to which the design was qualified. The latest version of MIL-STD-461 reflects the most up-to-date environments and concerns. Since the original EMI requirements may be substantially different than the latest version of MIL-STD-461, they may not be adequate to assess the suitability of the item in a particular installation. This situation most often occurs for equipment susceptibility tests related to the radiated electromagnetic environment. Procuring activities need to consider imposing additional test requirements on the contractor to gather additional data to permit adequate evaluation. The Navy and Army have found this additional testing to be especially necessary for their applications.

Testing of production items has shown degraded performance of the equipment from that previously demonstrated during development. One problem area is engineering changes implemented for ease of manufacturing which are not adequately reviewed for potential effects on EMI control design measures. Specific problems have been related to treatment of cable and enclosure shields and electrical grounding and bonding.

40.6 (4.6) Government furnished equipment (GFE). When it is demonstrated by the contractor that a GFE is responsible for failure of an equipment or subsystem to meet the contractual EMI requirements, the data indicating such failure shall be included in the EMITR (see 6.3). No modification shall be made unless authorized by the procuring activity.

DISCUSSION: GFE is treated the same as commercial items specified by the procuring activity.

40.7 (4.7) Testing requirements. The testing requirements and procedures of MIL-STD-462 shall be used to determine compliance with the applicable emission and susceptibility requirements of this standard. Data gathered as a result of performing tests in one electromagnetic discipline may be

MIL-STD-461D
APPENDIX

sufficient to satisfy requirements in another. Therefore, to avoid unnecessary duplication, a single test program should be established with tests for similar requirements conducted concurrently whenever possible. Equipment that are intended to be operated as a subsystem shall be tested as such to the applicable emission and susceptibility requirements whenever practical. Formal testing is not to commence without approval of the Electromagnetic Interference Test Procedures (EMITP) (See 6.3) by the Command or agency concerned.

DISCUSSION: MIL-STD-462 is a parallel document to MIL-STD-461. MIL-STD-461 specifies design requirements and MIL-STD-462 specifies general test methodology together with detailed methods to demonstrate compliance with MIL-STD-461.

Electromagnetic disciplines (electromagnetic compatibility (EMC), electromagnetic pulse (EMP), lightning, RF compatibility, frequency allocation, etc.) are integrated to differing levels in various government and contractor organizations. There is often a common base of requirements among the disciplines. It is more efficient to have unified requirements and complete and concise testing. For example, the EMC, EMP and lightning areas all pertain to electronic hardness to transients. The transient requirements in MIL-STD-461 and MIL-STD-462 should satisfy most concerns or should be adapted as necessary to do so.

Testing integrated equipment at the subsystem-level is advantageous because the actual electrical interfaces are in place rather than electrical load or test equipment simulations. When simulations are used, there is always doubt regarding the integrity of the simulation and questions arise whether emission and susceptibility problems are due to the equipment under test or the simulation.

Test procedures provide a mechanism to interpret and adapt MIL-STD-461 and MIL-STD-462 as they are applicable to a particular subsystem or equipment and to detail the test agency's facilities and instrumentation and their use. It is important that the procedures are available to the procuring activity early so that the procuring activity can approve the test procedures prior to the start of testing. Agreement needs to exist between the procuring activity and the contractor on the interpretation of test requirements and methodology, thereby minimizing the possible need for retesting.

40.8 (4.8) Switching transients. Switching transient emissions that result at the moment of operation of manually actuated switching functions are exempt from the requirements of this standard. Other transient type conditions, such as automatic sequencing following initiation by a manual switching function, shall meet the emissions requirements of this standard.

MIL-STD-461D
APPENDIX

DISCUSSION: Proper treatment of manually actuated switching functions has long been a dilemma. Platform experience has shown that switching of electronics equipment subjected to EMI requirements rarely causes electromagnetic compatibility problems. On this basis, there are no requirements included in this standard. "On-off" switching has been of particular interest. On-off switching has occasionally caused power quality type problems. These problems are associated with voltage regulation difficulties from a large load being switched on a power bus; however, such power quality issues are not addressed by this standard.

Platform problems have also been observed from switching of items not normally subjected to EMI requirements such as unsuppressed inductors (valves, relays, etc.), motors, and high current resistive loads. These types of problems are more related to coupling of transients onto platform wiring through electric and magnetic fields than direct conduction of the interference. There are substantial requirements included in the standard to protect against susceptibility to transients. This statement is not intended to imply that inductive devices and other transient producers should not be suppressed as a normal good design practice. For example, some integrating contractors routinely require vendors to provide diode suppression on inductors.

In earlier versions of EMI standards, manually actuated functions were measured using frequency domain techniques. Although measured emission levels were often 40-70 dB above the limit, no platform problems were observed. This technique was largely abandoned in later versions of the standards in favor of a time domain requirement on power leads (CE07). Except for some above limit conditions associated with on-off functions, equipment rarely have had any problems with the requirement. Testing of on-off functions has often been controversial because of the need to often use a switch external to the equipment. A number of issues arise regarding placement of the switch, where the transient should be measured, whether the switch or the equipment causes the transient, and whether the switch can be suppressed.

The exemption is applicable only for transient effects occurring at the moment of manual switch operation. Many other transient type effects occur during the operation of electronics. An argument could be made that the operation of microprocessor controlled electronics produces continuous transients with every change of state. There are certain transient effects which occur infrequently that could be presented to the procuring activity as events similar to the action of a manual switch with a request for an exemption. An example is a heater circuit which functions intermittently dependent upon a sensed temperature.

MIL-STD-461D
APPENDIX

Other documents such as MIL-STD-704 and MIL-E-6051 for aircraft impose transient controls at the system-level.

MIL-STD-461D
APPENDIX

50. DETAILED REQUIREMENTS

50.1 (5.1) General. Table I is a list of emissions and susceptibility requirements established by this standard. General test methods for these requirements are contained in MIL-STD-462 as implemented by the Government approved EMITP (see 6.3). All results of tests performed to demonstrate compliance with the requirements are to be documented in the EMITR (see 6.3) and forwarded to the Command or agency concerned for evaluation prior to acceptance of the equipment or subsystem. Design procedures and techniques for the control of EMI shall be described in the EMICP (see 6.3). Approval of design procedures and techniques described in the EMICP does not relieve the supplier of the responsibility of meeting the contractual emission, susceptibility, and design requirements.

DISCUSSION: The applicability of individual requirements in Table I for a particular equipment or subsystem is dependent upon the platforms where the item will be used. The electromagnetic environments present on a platform together with potential degradation modes of electronic equipment items play a major role regarding which requirements are critical to an application. For example, emissions requirements are tied to protecting antenna-connected receivers on platforms. The operating frequency ranges and sensitivities of the particular receivers on-board a platform, therefore, influence the need for certain requirements.

The EMICP, EMITP, and EMITR are important elements in documenting design efforts for meeting the requirements of this standard, testing approaches which interpret the generalized test methods in MIL-STD-462, and reporting of the results of testing. The EMICP is a mechanism instituted to help ensure that contractors analyze equipment design for EMI implications and include necessary measures in the design for compliance with requirements. Approval of the document does not indicate that the procuring activity agrees that all the necessary effort is stated in the document. It is simply a recognition that the design effort is addressing the correct issues.

The susceptibility limits are the upper bound on the range of values for which compliance is required. The EUT must also provide required performance at any stress level below the limit. For example, if the limit for radiated susceptibility to electric fields is 10 volts/meter, the EUT must also meet its performance requirements at 5 volts/meter or any other field less than or equal to 10 volts/meter. There have been cases where equipment has met its EMI requirements at the limit, but it has failed elsewhere.

MIL-STD-461D
APPENDIX

50.1.1 (5.1.1) Units of frequency domain measurements. All frequency domain limits are expressed in terms of equivalent root mean square (RMS) value of a sine wave as would be indicated by the output of a measurement receiver using peak envelope detection.

DISCUSSION: A detailed discussion is provided on peak envelope detection in the MIL-STD-462 appendix for paragraph 4.10.1. A summary of output of the detector for several input waveforms is as follows. For an unmodulated sine wave, the output simply corresponds to the RMS value of the sine wave. For a modulated sine wave, the output is the RMS value of an unmodulated sine wave with the same absolute peak value. For a signal with a bandwidth greater than the bandwidth of the measurement receiver, the output is the RMS value of an unmodulated sine wave with the same absolute peak value as the waveform developed in the receiver bandpass.

50.2 (5.2) EMI control requirements versus intended installations. Table II summarizes the requirements for equipment and subsystems intended to be installed in, on, or launched from various military platforms or installations. When an equipment or subsystem is to be installed in more than one type of platform or installation, it shall comply with the most stringent of the applicable requirements and limits. An "A" entry in the table means the requirement is applicable. An "L" entry means the applicability of the requirement is limited as specified in the appropriate requirement paragraph of this standard. An "S" entry means the procuring activity must specify the applicability and limit requirements in the procurement specification. Absence of an entry means the requirement is not applicable.

DISCUSSION: Discussion on each requirement as it relates to different platforms is contained in the sections on the individual requirements.

50.3 (5.3) Emission and susceptibility requirements and limits.

50.3.1 (5.3.1) CE101 (Conducted emissions, power leads, 30 Hz to 10 kHz).

DISCUSSION: The requirements are applicable to leads that obtain power from sources which are not part of the EUT. There is no requirement on output leads from power sources. Since power quality standards are normally used to govern the characteristics of output power, there is no need for separate EMI requirements on output leads.

MIL-STD-461D
APPENDIX

The limits are in terms of current because of the difficulty in controlling the power source impedance in test facilities at lower frequencies. This type of control would be necessary to specify the limits in terms of voltage. Emission current levels will be somewhat independent of power source impedance variations as long as the impedance of the emission source is large relative to the power source impedance.

For Navy surface ships and submarines, the intent of this requirement is to control the effects of conducted emissions peculiar to the shipboard power distribution system. Harmonic line currents are limited for each electrical load connected to the power distribution system. Power quality for ships is controlled by MIL-STD-1399, Section 300.

The ship service power distribution system (ship's primary power) supplied by the ship's alternators is 440 VAC, 60 Hz, 3-phase, 3-wire, delta-connected, ungrounded. Although ship's primary power is ungrounded, there exists a virtual alternating current (AC) ground at each electrical load due to capacitance to chassis. The unbalance between the virtual grounds at each electrical load causes AC currents to flow in the hull of the ship. These hull currents can degrade the performance of electronic equipment, upset ground detectors, and counteract degaussing.

Hull currents are controlled by limiting the amplitude of harmonic currents conducted on the power distribution system wiring for each electrical load. The limit is based on maintaining total harmonic distortion of the ship power distribution system within 5% of the supply voltage with the contribution from any single harmonic being less than 3%. In addition to the hull current concern, total harmonic distortion greater than 5% is above the tolerance of most electronic equipment, induction motors, magnetic devices, and measuring devices.

For Army aircraft, the primary concern is to ensure that the EUT does not corrupt the power quality (allowable voltage distortion) on the power busses present on the platform. The Army aircraft limits are based on relating the allowable current flowing into a 1.0 ohm impedance to MIL-STD-704 requirements on voltage distortion. The Army limit includes approximately a 20 dB margin with respect to MIL-STD-704 to allow for contributions from multiple emission sources.

For Navy aircraft, the requirement is applicable for installations using anti-submarine warfare (ASW) equipment. The primary mission of ASW aircraft is to detect and locate submarines. Unacceptable levels of emission currents in the frequency range of this test would limit the detection and

MIL-STD-461D
APPENDIX

processing capabilities of the Magnetic Anomaly Detection (MAD) and Acoustic Sensor systems. The MAD systems must be able to isolate a magnetic disturbance in the earth's magnetic field of less than one part in 50,000. In present aircraft, the full sensitivity of the MAD systems is not available due to interference produced by onboard equipment. Low frequency effects in the 30 Hz to 10 kHz can be a problem for Acoustic Sensor systems.

The Air Force has not generally imposed this type of requirement in the past (particularly in the case of aircraft), and no platform problems have resulted. This situation is probably due to the low source impedances present in Air Force power generation systems at the lower frequencies. Also, the Air Force does not usually utilize tuned receivers operating in the frequency range of the requirement.

Possible tailoring of the requirements by the procuring activity is to impose the requirement if sensitive receivers operating in the frequency range of the requirement are to be installed on a platform or to modify the limit based on the particular characteristics of the power system onboard the platform.

50.3.2 (5.3.2) CE102 (Conducted emissions, power leads, 10 kHz to 10 MHz).

DISCUSSION: The requirements are applicable to leads that obtain power from sources which are not part of the EUT. There is no requirement on output leads from power sources.

The basic concept in the lower frequency portion of the requirement is to ensure that the EUT does not corrupt the power quality (allowable voltage distortion) on the power busses present on the platform. Examples of power quality documents are MIL-STD-704 for aircraft, MIL-STD-1399 for ships, MIL-STD-1539 for space systems, and MIL-STD-1275 for military vehicles.

Since power quality standards govern allowable distortion on output power, there is no need for separate EMI requirements on output leads. The output power leads are treated no differently than any other electrical interface. This standard does not directly control the spectral content of signals present on electrical interfaces. Waveform definitions and distortion limits are specified in documents such as interface control documents. In the case of output power, the quality of the power must be specified over an appropriate frequency range so that the user of the power can properly design. This situation is true whether the power source is a primary source such as 115 volts, 400 Hz, or a ± 15 VDC low current supply. A significant indirect control on spectral content exists in the RE102 limits

MIL-STD-461D
APPENDIX

which essentially require that appropriate waveform control and signal transmission techniques be used to prevent unacceptable radiation (see discussion on CE102 limit placement and RE102 relationship below). An important issue, which is often ignored, is that some requirements such as CS114 and RS103 will induce substantial voltage and current levels on electrical interfaces. Controlling directly conducted interference to low levels can be a poorly directed effort if the interfacing equipment can tolerate the much higher stresses associated with the susceptibility tests.

Since voltage distortion is the basis for establishing power quality requirements, the CE102 limit is in terms of voltage. The use of a standardized line impedance over the frequency range of this test provides for the convenient measurement of the voltage as developed across this impedance. In previous versions of MIL-STD-461, a current measurement into a 10 microfarad feedthrough capacitor was specified. The intent of the capacitor was to provide an RF short of the power lead to the ground plane. It was difficult to interpret the significance of the current limit with respect to platform applications. The presence of a standardized impedance is considered to reflect more closely the electrical characteristics of the power busses in platforms.

Of the power quality documents reviewed, MIL-STD-704 is the only one with a curve specifying an amplitude versus frequency relationship for the allowable distortion. The CE102 limits require that amplitude decays with increasing frequency similar to the requirements of MIL-STD-704. Common requirements are specified for all applications since the concerns are the same for all platforms.

The basic limit curve for 28 volts is placed approximately 20 dB below the power quality curve in MIL-STD-704. There are several reasons for the placement. One reason is that a number of interference sources present in different subsystems and equipments on a platform may be contributing to the net interference voltage present at a given location on the power bus. Assuming that the interference sources are not phase coherent, the net voltage will be the square root of the sum of the squares of the voltages from the individual sources. A second reason is that the actual impedance in an installation will vary from the control impedance with actual voltages being somewhat higher or lower than that measured during the test. Therefore, some conservatism needs to be included in the limit.

The relaxation for other higher voltage power sources is based on the relative levels of the power quality curves on ripple for different operating voltages.

MIL-STD-461D
APPENDIX

At higher frequencies, the CE102 limit serves as a separate control from RE102 on potential radiation from power leads which may couple into sensitive antenna-connected receivers. The CE102 limits have been placed to ensure that there is no conflict with the RE102 limit. Emissions at the CE102 limit should not radiate above the RE102 limit. Laboratory experiments on coupling from a 2.5 meter power lead connected to a line impedance stabilization network have shown that the electric field detected by the RE102 rod antenna is flat with frequency up to approximately 10 MHz and is approximately equal to $(X-40)$ dB μ V/m, where X is the voltage expressed in dB μ V. For example, if there is a signal a level of 60 dB μ V on the lead, the detected electric field level is approximately 20 dB μ V/m.

Tailoring of the requirements in contractual documents may be desirable by the procuring activity. Adjusting the limit line to more closely emulate a spectral curve for a particular power quality standard is one possibility. Contributions from multiple interference sources need to be considered as noted above. If antenna-connected receivers are not present on the platform at the higher frequencies, tailoring of the upper frequency of the requirement is another possibility. The requirement is limited to an upper frequency of 10 MHz due to the allowable 2.5 meter length of power lead in the test setup approaching resonance. Any conducted measurements become less meaningful above this frequency. If tailoring is done to impose the requirement at higher frequencies, the test setup should be modified for CE102 to shorten the allowable length of the power leads.

50.3.3 (5.3.3) CE106 (Conducted emissions, antenna terminal, 10 kHz to 40 GHz).

DISCUSSION: The requirement is applicable for transmitters and receivers. The basic concern is to protect antenna-connected receivers both on and off the platform from being degraded due to radiated interference from the antenna associated with the EUT. The limit for transmitters in the transmit mode is placed primarily at levels which are considered to be reasonably obtainable for most types of equipment. Suppression levels that are required to eliminate all potential electromagnetic compatibility situations are often much more severe and could result in significant design penalties. The limit for receivers and transmitters in standby is placed at a level which provides reasonable assurance of compatibility with other equipment. Common requirements are specified for all applications since the concerns are the same for all platforms.

As an example of an antenna coupling situation, consider a 10 watt VHF-AM transmitter operating at 150 MHz and a UHF-AM receiver with a sensitivity of -100 dBm tuned to 300 MHz with isotropic antennas located 10 meters apart. The requirement is

MIL-STD-461D
APPENDIX

that the transmitter second harmonic at 300 MHz must be down $50 + 10 \log 10 = 60$ dB. The free space loss equation $P_R/P_T = (\lambda^2 G_T G_R) / (4\pi R)^2$ indicates an isolation of 42 dB between the two antennas.

P_R = Received Power G_R = Receive Antenna Gain = 1
 P_T = Transmitted Power G_T = Transmitter Antenna Gain = 1
 λ = Wavelength = 1 meter
 R = Distance between Antennas = 10 meters

A second harmonic at the limit would be $60 + 42 = 102$ dB down at the receiver. 102 dB below 10 Watts (40 dBm) is -62 dBm which is still 38 dB above the receiver sensitivity. The level which is actually required not to cause any degradation in the receiver is -123 dBm. This value results because the worst-case situation occurs when the interfering signal is competing with the sidebands of the intentional signal with a signal amplitude at the receiver sensitivity. For a standard tone of 30% AM used to verify sensitivity, the sidebands are 13 dB down from the carrier and a 10 dB signal-to-noise ratio is normally specified. To avoid problems, the interfering signal must, therefore, be $13 + 10 = 23$ dB below -100 dBm or -123 dBm. This criterion would require the second harmonic to be 121 dB down from the transmitter carrier which could be a difficult task. Harmonic relationships can sometimes be addressed through frequency management actions to avoid problems.

Assessing the 34 dB μ V (-73 dBm) requirement for standby, the level at the receiver would be -115 dBm which could cause some minimal degradation in the presence of a marginal intentional signal.

Greater antenna separation or antenna placement not involving direct line of sight would improve the situation. Also, the VHF antenna may be poorer than isotropic in the UHF band. CE106 does not take into account any suppression associated with frequency response characteristics of antennas; however, the results of the case cited are not unusual. RE103, which is a radiated emission control on spurious and harmonic outputs, includes assessment of antenna characteristics.

Since the free space loss equation indicates that isolation is proportional to the wavelength squared, isolation values improve rapidly as frequency increases. Also, antennas are generally more directional in the GHz region and receivers tend to be less sensitive due to larger bandwidths.

The procuring activity may consider tailoring contractual documents by establishing suppression levels based on antenna-to-antenna coupling studies on the particular platform where the

MIL-STD-461D
APPENDIX

equipment will be used. Another area could be relaxation of requirements for high power transmitters. The standard suppression levels may result in significant design penalties. For example, filtering for a 10,000 watt HF transmitter may be excessively heavy and substantially attenuate the fundamental frequency. Engineering trade-offs may be necessary.

50.3.4 (5.3.4) CS101 (Conducted susceptibility, power leads, 30 Hz to 50 kHz).

DISCUSSION: The requirement is applicable to power input leads that obtain power from other sources which are not part of the EUT. There is no requirement on power output leads. The basic concern is to ensure that equipment performance is not degraded from ripple voltages associated with allowable distortion of power source voltage waveforms.

The required signal is applicable only to the high sides on the basis that the concern is developing a differential voltage across the power input leads to the EUT. The series injection technique in MIL-STD-462 results in the voltage dropping across the impedance of the EUT power input circuitry. The impedance of the power return wiring is normally insignificant with respect to the power input over most of the required frequency range. Common mode voltages evaluations are addressed by other susceptibility tests such as CS114 and RS103. Injection on a power return will result in the same differential voltage across the power input; however, the unrealistic condition will result in a large voltage at the return connection to the EUT with respect to the ground plane.

Similar to CE102, the limits are based on a review of the power quality standards with emphasis toward the spectral content curves present in MIL-STD-704. Rather than having a separate curve for each possible power source voltage, only two curves are specified. The voltage amplitude specified is approximately 6 dB above typical power quality limits, although the limit has been somewhat generalized to avoid complex curves. The margin between the limit and the power quality standard is necessary to allow for variations in performance between manufactured items.

The difference between the limits for CE102 and CS101 of approximately 26 dB should not be viewed as a margin. The CE102 limit is placed so that ripple voltages do not exceed that allowed by the power quality standards due to interference contributions from multiple EUTs. Therefore, the power quality standard is the only valid basis of comparison.

The primary tailoring consideration for the procuring activity for contractual documents is adjustment of the limit to follow more closely a particular power quality standard.

MIL-STD-461D
APPENDIX

50.3.5 (5.3.5) CS103 (Conducted susceptibility, antenna port, intermodulation, 15 kHz to 10 GHz).

DISCUSSION: The intent of this requirement is to control the response of antenna-connected receiving subsystems to in-band signals resulting from potential intermodulation products of two signals outside of the intentional passband of the subsystem produced by non-linearities in the subsystem. The requirement can be applied to receivers, transceivers, amplifiers, and the like. Due to the wide diversity of subsystem designs being developed, the applicability of this type of requirement and appropriate limits need to be determined for each procurement. Also, requirements need to be specified that are consistent with the signal processing characteristics of the subsystem and the particular test methodology to be used to verify the requirement.

One approach for determining levels required for the out-of-band signals is from an analysis of the electromagnetic environments present and characteristics of receiving antennas. However, levels calculated by this means will often place unreasonable design penalties on the receiver. For example, if an external environment of 200 volts/meter is imposed on a system, an isotropic antenna at 300 MHz will deliver 30 dBm to the receiver. This level represents a severe design requirement to many receivers. An alternative approach is to simply specify levels which are within the state-of-the-art for the particular receiver design.

This requirement is most applicable to fixed frequency, tunable, superheterodyne receivers. Previous versions of this standard required normal system performance with the two out-of-band signals to be 66 dB above the level required to obtain the standard reference output for the receiver. One signal was raised to 80 dB above the reference in the 2 to 25 MHz and 200 to 400 MHz bands to account for transmissions from HF and UHF communication equipment. Maximum levels for both signals were limited to 10 dBm. As an example, conventional communication receivers commonly have sensitivities on the order of -100 dBm. For this case, the 66 dB above reference signal is at -34 dBm and the 80 dB above reference signal is at -20 dBm. Both are substantially below the 10 dBm maximum used in the past.

For other types of receivers, application of this requirement is often less straightforward and care must be taken to ensure that any applied requirements are properly specified. Many receivers are designed to be interference or jam resistant and this feature may make application of this requirement difficult or inappropriate.

One complicating factor is that one of the out-of-band signals typically is modulated with a waveform normally used by

MIL-STD-461D
APPENDIX

the receiver. For receivers that process a very specific modulation, the issue exists whether an out-of-band signal can reasonably be expected to contain that modulation. Another complicating factor is related to the potential intermodulation products resulting from two signals. Responses from intermodulation products can be predicted to occur when $f_o = mf_1 \pm nf_2$ where f_o is the operating frequency of the receiver, m and n are integers, and f_1 and f_2 are the out-of-band signals. For receivers which continuously change frequency (such as frequency agile or frequency hopping), the relationship will be true only for a portion of the operating time of the receiver, unless the out-of-band-signals are also continuously tuned or the receiver operating characteristics are modified for the purpose of evaluation.

50.3.6 (5.3.6) CS104 (Conducted susceptibility, antenna port, rejection of undesired signals, 30 Hz to 20 GHz).

DISCUSSION: The intent of this requirement is to control the response of antenna-connected receiving subsystems to signals outside of the intentional passband of the subsystem. The requirement can be applied to receivers, transceivers, amplifiers, and the like. Due to the wide diversity of subsystem designs being developed, the applicability of this type of requirement and appropriate limits need to be determined for each procurement. Also, requirements need to be specified that are consistent with the signal processing characteristics of the subsystem and the particular test methodology to be used to verify the requirement.

One approach for determining levels required for the out-of-band signal can be determined from an analysis of the electromagnetic environments present and characteristics of receiving antennas. However, levels calculated by this means will often place unreasonable design penalties on the receiver. For example, if an external environment of 200 volts/meter is imposed on a system, an isotropic antenna at 300 MHz will deliver 30 dBm to the receiver. This level represents a severe design requirement to many receivers. An alternative approach is to simply specify levels which are within the state-of-the-art for the particular receiver design.

This requirement is most applicable to fixed frequency, tunable, superheterodyne receivers. Previous versions of this standard required normal system performance for a 0 dBm signal outside of the tuning range of the receiver and a signal 80 dB above the level producing the standard reference output within the tuning range (excluding the receiver passband within the 80 dB points on the selectivity curve). As an example, a conventional UHF communication receiver operating from 225 MHz to 400 MHz commonly has a sensitivity on the order of -100 dBm. For

MIL-STD-461D
APPENDIX

this case, the 0 dBm level applies below 225 MHz and above 400 MHz. Between 225 MHz and 400 MHz (excluding the passband), the required level is -20 dBm.

For other types of receivers, application of this requirement is often less straightforward and care must be taken to ensure that any applied requirements are properly specified. Many receivers are designed to be interference or jam resistant and this feature may make application of this requirement difficult or inappropriate.

This requirement is usually specified using either one or two signals. With the one signal requirement, the signal is out-of-band to the receiver and is modulated with a waveform normally used by the receiver. No in-band signal is used. For receivers that process a very specific modulation, the issue exists whether an out-of-band signal can reasonably be expected to contain that modulation. An alternative is to specify the requirement for two signals. An in-band signal can be specified which contains the normal receiver modulation. The out-of-band signal can be modulated or unmodulated with the criterion being that no degradation in reception of the intentional signal is allowed.

50.3.7 (5.3.7) CS105 (Conducted susceptibility, antenna port, cross modulation, 30 Hz to 20 GHz).

DISCUSSION: The intent of this requirement is to control the response of antenna-connected receiving subsystems to modulation being transferred from an out-of-band signal to an in-band signal. This effect results from a strong, out-of-band signal near the operating frequency of the receiver which modulates the gain in the front-end of the receiver and adds amplitude varying information to the desired signal. The requirement should be considered only for receivers, transceivers, amplifiers, and the like, which extract information from the amplitude modulation of a carrier. Due to the wide diversity of subsystem designs being developed, the applicability of this type of requirement and appropriate limits need to be determined for each procurement. Also, requirements need to be specified that are consistent with the signal processing characteristics of the subsystem and the particular test methodology to be used to verify the requirement.

One approach for determining levels required for the out-of-band signal can be determined from an analysis of the electromagnetic environments present and characteristics of receiving antennas. However, levels calculated by this means will often place unreasonable design penalties on the receiver. For example, if an external environment of 200 volts/meter is imposed on a system, an isotropic antenna at 300 MHz will deliver 30 dBm to the receiver. This level represents a severe design

MIL-STD-461D
APPENDIX

requirement to many receivers. An alternative approach is to simply specify levels which are within the state-of-the-art for the particular receiver design.

This requirement is most applicable to fixed frequency, tunable, superheterodyne receivers. Previous versions of this standard required normal system performance with an out-of-band signal to be 66 dB above the level required to obtain the standard reference output for the receiver. The maximum level for the signal was limited to 10 dBm. As an example, conventional communication receivers commonly have sensitivities on the order of -100 dBm. For this example, the 66 dB above reference signal is at -34 dBm which is substantially below the 10 dBm maximum used in the past.

For other types of receivers, application of this requirement is often less straightforward and care must be taken to ensure that any applied requirements are properly specified. Many receivers are designed to be interference or jam resistant and this feature may make application of this requirement difficult or inappropriate.

One complicating factor is that one of the out-of-band signals typically is modulated with a waveform normally used by the receiver. For receivers that process a very specific modulation, the issue exists whether an out-of-band signal can reasonably be expected to contain that modulation. Another factor is that the out-of-band signal is normally specified to be close to the receiver operating frequency. For receivers which continuously change frequency (such as frequency agile or frequency hopping), an appropriate relationship may exist for only short periods for a fixed frequency out-of-band signal.

50.3.8 (5.3.8) CS109 (Conducted susceptibility, structure current, 60 Hz to 100 kHz).

DISCUSSION: This requirement is specialized and is intended to be applied only for very sensitive equipment (1 μ V or better) such as tuned receivers operating over the frequency range of the test. The basic concern of the requirement is to ensure that equipment does not respond to magnetic fields caused by currents flowing in platform structure and through EUT housing materials. The magnetic fields are sufficiently low that there is no concern with most circuitry.

An estimate can be made of induced voltages that may result from the required CS109 currents. Magnetic fields act by inducing voltages into loop areas in accordance with Faraday's law ($V = -d\phi/dt$). For a constant magnetic field perpendicular to a given loop area, Faraday's law reduces to $V = -2\pi fBA$ where

MIL-STD-461D
APPENDIX

f = Frequency of Interest B = Magnetic Flux Density

A = Loop Area

Since Faraday's law indicates that these voltages are proportional to frequency, the maximum voltage from the CS109 currents will result at the 20 kHz knee of the curve for a given loop area. A drop of 20 dB/decade would result in a constant voltage. Since the curve is dropping at only 10 dB/decade below 20 kHz, the induced voltage will rise as frequency increases. The sharp drop off above 20 kHz results in decreasing voltages with increasing frequency.

If the 103 dB μ A current at 20 kHz specified in the requirement is assumed to spread uniformly over a cross-sectional dimension of 10 cm, the surface current density and the resulting magnetic field intensity at the surface would be 1.41 amperes/meter. In air, this value corresponds to magnetic flux density of (1.77) (10^{-6}) Tesla. If it is further assumed that this magnetic field is uniform over a circuit loop area of 0.001 m² (such as 20 cm by 0.5 cm) within the enclosure, Faraday's Law predicts an induced voltage of 222 μ V.

Similar calculations at 400 Hz and 100 kHz yields values of 31 μ V and 8 μ V, respectively.

It is apparent that design considerations such as proper grounding techniques, minimizing of loop areas, and common mode rejection concepts need to be implemented to prevent potential problems with very sensitive circuits used in submarines such as low frequency tuned receivers. However, these levels are well below the sensitivity of typical circuits used in other equipment.

The limit is derived from operational problems due to current conducted on equipment cabinets and laboratory measurements of response characteristics of selected receivers.

No tailoring is recommended.

50.3.9 (5.3.9) CS114 (Conducted susceptibility, bulk cable injection, 10 kHz to 400 MHz).

DISCUSSION: The requirements are applicable to all electrical cables interfacing with the EUT enclosures. The basic concept is to simulate currents which will be developed on platform cabling from electromagnetic fields generated by antenna transmissions both on and off the platform.

An advantage of this type of requirement is that it provides data which can be directly related to induced current levels

MIL-STD-461D
APPENDIX

measured during platform-level evaluations. An increasingly popular technique is to illuminate the platform with a low level, relatively uniform field while monitoring induced levels on cables. Then, either laboratory data can be reviewed or current injection done at the platform with the measured currents scaled to the full threat level. This same philosophy has been applied to lightning and electromagnetic pulse testing.

Due to size constraints and available field patterns during radiated susceptibility testing (such as RS103), it has long been recognized that cabling cannot be properly excited to simulate platform effects at lower frequencies. The most notable example of this situation is experience with HF (2 - 30 MHz) radio transmissions. HF fields have caused numerous problems in platforms through cable coupling. However, equipment items rarely exhibit problems in this frequency range during laboratory testing.

The limits are primarily derived from testing on aircraft which were not designed to have intentionally shielded volumes. The basic structure is electrically conductive; however, there was no attempt to ensure continuous electrical bonding between structure members or to close all apertures. The shape of the limit reflects the physics of the coupling with regard to resonant conditions, and the cable length with respect to the interfering frequency wavelength. At frequencies below resonance, coupling is proportional to frequency (20 dB/decade slope). Above resonance, coupled levels are cyclic with frequency with a flat maximum value. The 10 dB/decade decrease in the limit level at the upper frequency portion is based on actual induced levels in the aircraft testing data base when worst-case measurements for the various aircraft are plotted together. From coupling theory for a specific cable, the decrease would be expected to be cyclic with frequency with an envelope slope of 40 dB/decade.

The basic relationship for the limit level in the resonance (flat) portion of the curve is 1.5 milliamperes per volt/meter which is derived from worst-case measurements on aircraft. For example, 110 dB μ A corresponds to 200 volts/meter. At resonance, the effective shielding effectiveness of the aircraft can be zero. Application of these results to other platforms is reasonable.

The frequency coverage varies dependent on application. A basic issue is the required upper frequency. In some of the applications, the requirement stops at 30 MHz. This frequency is specified under the assumption that RS103 adequately provides any required performance at higher frequencies. The requirement is continued to 200 MHz for aircraft applications primarily for reasons of clearing aircraft as safe to fly. These results are

MIL-STD-461D
APPENDIX

used as the basis of comparison to induced levels measured during system-level testing in the presence of external environments.

Possible tailoring by the procuring activity for contractual documents is a curve amplitude based on the expected field intensity for the installation and a breakpoint for the curve based on the lowest resonance associated with the platform. Tailoring of the frequency of application can be done based on the operating frequencies of antenna-radiating equipment. Tailoring should also include transmitters that are not part of the platform. For equipment used in benign environments, the requirement may not be necessary.

50.3.10 (5.3.10) CS115 (Conducted susceptibility, bulk cable injection, impulse excitation).

DISCUSSION: The requirements are applicable to all electrical cables interfacing with EUT enclosures. The basic concern is to protect equipment from fast rise and fall time transients that may be present due to platform switching operations and external transient environments such as lightning and electromagnetic pulse. The requirement is intended to replace "chattering relay" type requirements (RS06 in the previous version of MIL-STD-461) commonly used in procurements of equipment for aircraft applications in the past. The chattering relay has been criticized as unscientific and non-repeatable. The CS115 requirement has a defined waveform and a repeatable coupling mechanism.

The 2 nanosecond rise time is consistent with rise times possible for the waveforms created by inductive devices interrupted by switching actions. The 30 nanosecond pulse width standardizes the energy in individual pulses. In addition, it separates the rising and falling portions of the pulse so that each may act independently. Also, each portion may affect different circuits. The 5 ampere amplitude (500 volts across 100 ohm loop impedance calibration fixture) covers most induced levels that have been observed during system-level testing of aircraft to transient environments. The 30 Hz pulse rate is specified to ensure that a sufficient number of pulses are applied to provide confidence that the equipment will not be upset.

Many circuit interfaces are configured such that potential upset is possible for only a small percentage of the total equipment operating time. For example, a microprocessor may sequentially poll various ports for input information. A particular port may continuously update information between polling intervals. If the transient occurs at the time the port is accessed, an upset condition may result. At other times, no effect may occur.

MIL-STD-461D
APPENDIX

Possible tailoring by the procuring activity for contractual documents is lowering or raising the required amplitude based on the expected transient environments in the platform. Another option is to adjust the pulse width based on a particular environment onboard a platform or for control of the energy content of the pulse.

50.3.11 (5.3.11) CS116 (Conducted susceptibility, damped sinusoid transients, cables and power leads, 10 kHz to 100 MHz).

DISCUSSION: The requirements are applicable to all electrical cables interfacing with each EUT enclosure and also individually on each power lead. The basic concept is to simulate electrical current and voltage waveforms occurring in platforms from excitation of natural resonances.

When a platform is exposed to an external environment such as electromagnetic pulse or lightning, induced current and voltage waveforms within the platform are frequently damped sine waves or combinations of damped sine waves due to natural resonances. Transients caused from switching actions within the platform can also result in similar waveforms. Transient effects from platform switching actions on a particular power lead can cause a differential signal. Transients caused by external environments or coupled effects within the platform will cause common mode signals to be developed on cable interfaces. Both switching and external environment effects are addressed by the requirement.

A consideration for the requirement is whether momentary upsets are allowable if the EUT is capable of self-recovery to normal operation. Some upsets may occur that are not even noticed by an operator due to self-correcting mechanisms in the equipment. There may be cases where longer term upset is acceptable which may possibly require action by an operator to reset the equipment. The EMITP should address any instances where the contractor proposes that observable upsets be accepted.

A limited set of damped sine waves is specified to address a sampling of the various ringing frequencies that may be present in the platform. The additional resonant frequencies determined during testing are to evaluate the EUT at points of development of maximum current and voltage. An advantage of using a set of damped sine waves is that different circuit types are evaluated for various waveform attributes that may cause worst-case effects. Some circuits may respond to peak amplitude while others may respond to total energy or rate of rise.

The current limits are set at levels that cover most induced levels found in platforms during system-level testing to external

MIL-STD-461D
APPENDIX

transient environments. The level for aircraft also typically allows for designs which do not require the use of terminal protection devices. These items are generally undesirable due to concerns with hardness maintenance/hardness surveillance and the ability to assess whether protection remains effective. The lower frequency breakpoints are at worst-case platform resonant frequencies below which the response will fall off at 20 dB/decade. The upper frequency breakpoint is located where the spectral content of the transient environments fall off.

Possible tailoring of the requirements by the procuring activity in contractual documents is adjustment of the curve amplitude either higher or lower based on the degree of protection provided in the area of the platform where the equipment and interconnecting cabling will be located. A caution with this particular requirement based on past experiences is that the platform designer should be required to share in the burden of the hardening process by providing stress reduction measures in the platform. The equipment should not be expected to provide the total protection. Protection against transients generated internal to the platform needs to remain a consideration. Another potential tailoring area is adjusting the lower frequency breakpoint to be more consistent with the lowest resonance of a particular platform.

50.3.12 (5.3.12) RE101 (Radiated emissions, magnetic field, 30 Hz to 50 kHz).

DISCUSSION: This requirement is specialized and is intended primarily to control magnetic fields for applications where equipment is present in the installation which is potentially sensitive to magnetic induction at lower frequencies. The most common example is a tuned receiver which operates within the frequency range of the test.

RS101 is a complimentary requirement imposed on equipment to ensure compatibility with the anticipated magnetic fields. The RS101 limits have the same shape as the RE101 limits; however, the RS101 limits are 10 dB higher for Navy applications and 6 dB higher for Army aircraft applications. These differences are necessary to allow for variations in performance between manufactured items and to account for the possibility that the emissions from the EUT may couple into a larger physical area than that evaluated under the RS101 procedures in MIL-STD-462.

The Navy RE101 limits were derived by taking into account the allowable user equipment power line harmonic content (CE101), applicable cable types, shielding effectiveness of typical equipment cabinets, maximum anticipated power consumption of the user equipment, magnetic field radiation from current

MIL-STD-461D
APPENDIX

carrying cables, case and cable coupling contributions, and equipment circuit sensitivity.

Since the RE101 emissions of an EUT are usually related to its power consumption, relaxations similar to those for the Navy CE101 requirement were considered as a possibility for this standard. However, the many variables used to establish the RE101 limit makes any relaxations complex and a single limit is necessary. The specified limit is based on the maximum expected magnetic field emissions from most well-designed EUTs. Limits are specified at both 7 and 50 cm distances to allow for assessment of potential impacts in the actual installation. There may be instances where physical separation from potentially sensitive equipment is sufficient that a 50 cm control is adequate.

Some of the considerations in the limit are described below. Emissions at the lower frequencies are equipment related with regard to power type (60 Hz or 400 Hz, single or polyphase), EUT power load, and the shielding effectiveness of the enclosure. Emissions at the upper frequencies, above 1020 Hz for 60 Hz equipment and 12.8 kHz for 400 Hz equipment, are for the most part the result of magnetic field emissions from cabling. The type of cabling used in shipboard installations is driven by the power type and load and intentional signal parameters to be carried by the cables.

Note that the limit does not take into account magnetic effects from equipment such as magnetic launchers, magnetic guns and the like.

An estimate can be made of the types of induced levels which will result in circuitry from the limits. Magnetic fields act by inducing voltages into loop areas in accordance with Faraday's law ($V = -d\phi/dt$). For a uniform magnetic field perpendicular to the loop area, the induced voltage from Faraday's law reduces to $V = -2\pi fBA$.

f = Frequency of Interest B = Magnetic Flux Density

A = Loop Area

The Army aircraft RE101 limit is based on preventing induction of more than 2.5 millivolts (5 millivolts for RS101) in a 12.7 centimeter (5 inch) diameter loop. Since magnetic induction is proportional to frequency and the limit falls off at 20 dB/decade, the induced voltage in a given loop area is constant. Since the Army limit is greater than or equal to the Navy limit at all frequencies, this induced level represents the worst-case. The primary concerns are potential effects to

MIL-STD-461D
APPENDIX

engine, flight and weapon turret control systems and sensors which have sensitivities in the millivolt range.

The RE101 limits in this version of the standard are substantially relaxed from previous versions of the standard. Previous limits typically resulted in tens of microvolts being induced in loop areas. As noted above the present limits can result in a few millivolts worst-case. For many types of applications, this type of control has not been considered necessary in the past and has not been applied. Platform problems have not been observed in these situations.

There are certain limited applications in the Air Force where an RE101 requirement needs to be considered. These applications are primarily when a subsystem will be installed in an aircraft in close proximity to an antenna connected to a VLF/LF receiver. An appropriate limit needs to be chosen based upon distances between the equipment and the antenna.

For Army applications, possible tailoring is increasing the limit for single-use equipment that will be located a sufficient distance from any potentially susceptible systems or waiving of the requirement.

50.3.13 (5.3.13) RE102 (Radiated emissions, electric field, 10 kHz to 18 GHz).

DISCUSSION: The requirements are applicable to electric field emissions from the EUT and associated cables. The basic intent of the requirement is to protect sensitive receivers from interference coupled through the antennas associated with the receiver. Many tuned receivers have sensitivities on the order of one microvolt and are connected to an intentional aperture (the antenna) which are constructed for efficient reception of energy in the operating range of the receiver. The potential for degradation requires relatively stringent requirements to prevent platform problems.

There is no implied relationship between this requirement and RS103 which addresses radiated susceptibility to electric fields. Attempts have been made quite frequently in the past to compare electric field radiated emission and susceptibility type requirements as a justification for deviations and waivers. While RE102 is concerned with potential effects with antenna-connected receivers, RS103 simulates fields resulting from antenna-connected transmitters.

Often, the same equipment item will be involved in influencing both requirements. A 30 watt VHF-AM radio with a typical blade antenna operating at 150 MHz can easily detect a 40 dB μ V/m electric field (approximately -81 dBm developed at

MIL-STD-461D
APPENDIX

receiver input) while in the receive mode. When this same piece of equipment transmits at the same 150 MHz frequency, it will produce a field of approximately 150 dB μ V/m (32 volts/meter) at a 1 meter distance. The two field levels are 110 dB apart.

The limit curves are based on experience with platform-level problems with antenna-connected receivers and the amount of shielding typically between antennas and equipment and associated wiring.

The Air Force and Navy limit curve for equipment in internal installations is placed for an aircraft that is not designed to have intentionally shielded volumes which are effective across the frequency range of the test. Some minimal shielding is present. The curve for equipment in external installations is 10 dB more stringent because even this minimal shielding is not available.

The Air Force and Navy limit for internal equipment for the 30 to 400 MHz band, in particular, has been validated as being properly placed. Army investigations with aircraft have also shown the validity of the Army limit. It has become standard practice on some aircraft programs to use spectral analysis equipment wired to aircraft antennas to assess degradation due to radiated emissions from onboard equipment. Many problems due to out-of-limit conditions in this band have been demonstrated. It has also been determined that equipment meeting the limit generally do not cause problems. Most of this experience is on fighter size aircraft. The 20 dB/decade increase in the limit above 100 MHz is due to the aperture size of a tuned antenna ($G\lambda^2/(4\pi)$) decreasing with frequency. The coupled power level from an isotropic tuned antenna will remain constant. The curve breaks at 100 MHz because of difficulty with maintaining a tuned antenna due to increasing physical size and the lower likelihood of coupling to the antenna with longer wavelengths.

No Air Force and Navy limit is specified below 2 MHz. There are antennas on some aircraft that operate below 2 MHz; however, these antennas are usually magnetic loops which have an electrostatic shield. These antennas have very short electrical lengths with respect to the wavelength of frequencies below 2 MHz and any electric field coupling will be inefficient. With the exception of Army aircraft, there is no known history of coupling problems to these antennas or to cabling despite substantial above limit conditions with respect to past MIL-STD-461 requirements. The Army has had problems with low frequency automatic direction finding receivers primarily attributed to their use of helicopters which are physically small and have many larger apertures. The inefficient coupling to cabling at lower frequencies has been demonstrated innumerable times in MIL-STD-462 testing.

MIL-STD-461D
APPENDIX

The limits for Navy mobile and all Army ground equipment are the same. Also, the limits for Navy fixed and all Air Force ground equipment are identical. The 20 dB difference between the limits exists because of the general situations where the equipment is deployed. The Navy mobile is primarily oriented toward the Marines which operate in a fashion similar to the Army. Equipment is often very close to unprotected antennas such as installations in jeeps or tents or near physically small helicopter aircraft. The Navy fixed and most Air Force installations have less critical coupling situations with regard to antenna coupling.

The limit for ships is based on numerous documented incidents of case and cable radiation coupling to receiver antennas. The use of hand-held type transceivers below deck within a ship is increasing and can be plagued by excessive levels of interference below deck. The limit is more stringent than corresponding electric field radiation emissions requirements contained in military-related international agreements and standards such as those used by NATO.

Another issue is that there have been substantial conflicts between allowed radiated levels implied by the power quality limits of MIL-STD-704 and previous MIL-STD-461 requirements. For example, MIL-STD-704 allows approximately 0.63 volt RMS on 115 volt, 400 Hz, AC power busses at 15 kHz. Based on laboratory testing, this level will radiate at approximately 76 dB μ V/m. This level is 31 dB above the previous MIL-STD-461 limit for aircraft equipment. It is interesting to note that if the rod antenna in the MIL-STD-462 setup were usable down to 400 Hz, an approximate 1 volt/meter level would be indicated because of the power source waveform.

Possible tailoring by the procuring activity for contractual documents is as follows. The limits could be adjusted based on the types of antenna-connected equipment on the platform and the degree of shielding present between the equipment, associated cabling, and the antennas. For example, substantial relaxations of the limit may be possible for equipment and associated cabling located totally within a shielded volume with known shielding characteristics. It may be desirable to tailor the frequency coverage of the limit to include only frequency bands where antenna-connected receivers are present. Some caution needs to be exercised in this regard since there is always the chance the equipment will be added in the future. For example, it is not uncommon to add communications equipment (such as HF radio) onboard an aircraft as different missions evolve.

Based on the above discussion concerning MIL-STD-704, relaxing of RE102 limits for aircraft should be considered at

MIL-STD-461D
APPENDIX

lower frequencies for power generation equipment to avoid conflicts between the two sets of requirements.

50.3.14 (5.3.14) RE103 (Radiated emissions, antenna spurious and harmonic outputs, 10 kHz to 40 GHz).

DISCUSSIONS: The requirements are essentially identical with CE106 for transmitters in the transmit mode. There are no requirements for receivers or transmitters in the standby mode. Most of the discussion under CE106 also applies to RE103. A distinction between the requirements is that RE103 testing in MIL-STD-462 includes effects due to antenna characteristics. The test itself is considerably more difficult.

50.3.15 (5.3.15) RS101 (Radiated susceptibility, magnetic fields, 30 Hz to 50 kHz).

DISCUSSION: This requirement is specialized and intended primarily to ensure that performance of equipment potentially sensitive to low frequency magnetic fields is not degraded. RE101 is a complimentary requirement governing the radiated magnetic field emissions from equipment and subsystems. The RE101 discussion is also applicable to this requirement.

The RS101 limits have the same shape as the RE101 limits; however, the RS101 limits are 10 dB higher for Navy applications and 6 dB for Army aircraft applications. These differences are necessary to allow for variations in performance between manufactured items and to account for the possibility that the emissions from the EUT may couple into a larger physical area than that evaluated under the RS101 procedures in MIL-STD-462.

The Navy limits are based on the maximum expected magnetic field emissions from equipment and subsystems, including interconnecting cabling. The Army limits are based on 5 millivolts (independent of frequency) being induced in a 12.7 centimeter (5 inch) diameter loop.

50.3.16 (5.3.16) RS103 (Radiated susceptibility, electric field, 10 kHz to 40 GHz).

DISCUSSION: The requirements are applicable to both the EUT enclosures and EUT associated cabling. The basic concern is to ensure that equipment will operate without degradation in the presence of electromagnetic fields generated by antenna transmissions both onboard and external to the platform.

There is no implied relationship between this requirement and RE102. The RE102 limit is placed primarily to protect antenna-connected receivers while RS103 simulates fields resulting from antenna transmissions.

MIL-STD-4610
APPENDIX

The limits specified for different platforms are simply based on levels expected to be encountered during the service life of the equipment. They do not necessarily represent the worst-case environment to which the equipment may be exposed. RF environments can be highly variable, particularly for emitters not located on the platform. The limits are placed at levels which are considered to be adequate to cover most situations.

An example which demonstrates the variability of environments for ground installations and the need for effective tailoring of requirements is the installation of equipment in a large ground-based radar facility. Some of these facilities transmit power levels over one megawatt and the back lobes from the antennas can be substantial. Suitable design levels for equipment which will be used in the facility or nearby need to be imposed.

For aircraft and ships, different limits are specified depending on whether the equipment receives protection from platform structure. This distinction is not made for Army ground systems, such as tanks, because the same equipment used inside a structure is often used in other applications where protection is not available.

The 200 volt/meter requirement for Army aircraft regardless of the location or criticality of the equipment is based on the use of Army aircraft. Portions of the external environment accepted for most of the Army's aircraft is higher than 200 volts/meter. Army aircraft, especially rotary wing, have flight profiles which are almost exclusively nap-of-the-earth (NOE). The NOE profiles allow for much closer, and longer duration, encounters with high power emitters. This approach is similar to the FAA approach which recommends that Visual Flight Rules (VFR) helicopters be qualified to levels higher than fixed wing aircraft.

Circularly polarized fields are not allowed due to problems with using the spiral conical antennas specified in previous versions of MIL-STD-462. Circularly polarized fields were convenient since they avoided the need to rotate a linearly polarized antenna to obtain both polarizations of the radiated field. However, problems existed with this antenna. At some frequencies, the antenna pattern of the conical log spiral is not centered on the antenna axis. Also, the circular polarization of the conical log spiral creates confusion in its proper application. The EUT and associated cabling can be expected to respond more readily to linearly polarized fields. If a second spiral conical were used to calibrate the field radiated from the first spiral conical antenna, it would indicate an electric field 3 dB higher than a linearly polarized antenna. The question arises whether a 3 dB higher field should be used for a spiral

MIL-STD-461D
APPENDIX

conical transmit antenna to obtain response characteristics similar to a linearly polarized field. Similarly, if a spiral conical antenna were used to calibrate a linearly polarized field, the indication would be 3 dB below the true electric field strength.

Possible tailoring by the procuring activity for contractual documents is to modify the required levels and required frequency ranges based on the emitters on and near a particular installation. Actual field levels can be calculated from characteristics of the emitters, distances between the emitters and the equipment, and intervening shielding. MIL-HDBK-235 provides information on land, air, and sea based RF emitters, both hostile and friendly, which contribute to the overall electromagnetic environment. The possible use of the equipment in other installations and the potential addition or relocation of RF emitters needs to be considered. Other possible tailoring is to change from the standard 1 kHz, square wave, modulation or use additional modulations based on actual platform environments.

50.3.17 (5.3.17) RS105 (Radiated susceptibility, transient, electromagnetic field).

DISCUSSION: This requirement has limited applicability. It is primarily intended for equipment located outside platform structure exposed to incident transient electromagnetic fields. This requirement is applicable only for EUT enclosures. The electrical interface cabling should be protected in shielding conduit. Potential equipment responses due to cable coupling are controlled under CS116.

MIL-STD-461D
APPENDIX

conical transmit antenna to obtain response characteristics similar to a linearly polarized field. Similarly, if a spiral conical antenna were used to calibrate a linearly polarized field, the indication would be 3 dB below the true electric field strength.

Possible tailoring by the procuring activity for contractual documents is to modify the required levels and required frequency ranges based on the emitters on and near a particular installation. Actual field levels can be calculated from characteristics of the emitters, distances between the emitters and the equipment, and intervening shielding. MIL-HDBK-235 provides information on land, air, and sea based RF emitters, both hostile and friendly, which contribute to the overall electromagnetic environment. The possible use of the equipment in other installations and the potential addition or relocation of RF emitters needs to be considered. Other possible tailoring is to change from the standard 1 kHz, square wave, modulation or use additional modulations based on actual platform environments.

50.3.17 (5.3.17) RS105 (Radiated susceptibility, transient, electromagnetic field).

DISCUSSION: This requirement has limited applicability. It is primarily intended for equipment located outside platform structure exposed to incident transient electromagnetic fields. This requirement is applicable only for EUT enclosures. The electrical interface cabling should be protected in shielding conduit. Potential equipment responses due to cable coupling are controlled under CS116.

METRIC

MIL-STD-462D
11 JANUARY 1993

SUPERSEDING
MIL-STD-462
31 JULY 1967

MILITARY STANDARD

MEASUREMENT OF ELECTROMAGNETIC INTERFERENCE CHARACTERISTICS



AMSC N/A

AREA EMCS

DISTRIBUTION STATEMENT A. Approved for public release; distribution is unlimited.

MIL-STD-462D

FOREWORD

1. This military standard is approved for use by all Departments and Agencies of the Department of Defense.
2. Recommended corrections, additions, or deletions should be addressed to Aeronautical Systems Division (ENES), Wright-Patterson Air Force Base, Ohio, 45433-6503.
3. This standard contains the general test methods necessary to demonstrate compliance of subsystems and equipment to the requirements of MIL-STD-461. An appendix has been introduced which provides the rationale and background for each paragraph.
4. This standard is designated as revision "D" to coincide with its companion document, MIL-STD-461. Revisions "A," "B," and "C" of MIL-STD-462 were never issued.
5. Substantial changes have been made from previous editions. Some test methods have been eliminated, others significantly changed, and new ones added.
6. A joint committee consisting of representatives of the Army, Air Force, Navy, and Industry prepared this document.

MIL-STD-462D

CONTENTS

<u>PARAGRAPH</u>		<u>PAGE</u>
1.	SCOPE	1
1.1	Purpose	1
1.2	Application	1
1.3	Emission and susceptibility designations	1
2.	APPLICABLE DOCUMENTS	2
2.1	Government documents	2
2.1.1	Specifications, standards, and handbooks	2
2.1.2	Other Government documents, drawings, and publications	2
2.2	Non-Government publications	2
3.	DEFINITIONS	5
3.1	General	5
3.2	Acronyms used in this standard	5
3.3	Metric units	5
3.4	Test setup boundary	5
4.	REQUIREMENTS	6
4.1	General	6
4.1.1	Measurement tolerances	6
4.2	Shielded enclosures	6
4.2.1	Radio Frequency (RF) absorber material	6
4.3	Other test sites	7
4.4	Ambient electromagnetic level	7
4.5	Ground plane	7
4.5.1	Metallic ground plane	7
4.5.2	Composite ground plane	8
4.6	Power source impedance	8
4.7	General test precautions	8
4.7.1	Accessory equipment	8
4.7.2	Excess personnel and equipment	8
4.7.3	Overload precautions	8
4.7.4	RF hazards	9
4.7.5	Shock hazard	9
4.7.6	Federal Communications Commission (FCC) restrictions	9
4.8	EUT test configurations	9
4.8.1	Bonding of EUT	9
4.8.2	Shock and vibration isolators	9
4.8.3	Wire grounds	9
4.8.4	Orientation of EUTs	10
4.8.5	Construction and arrangement of EUT cables	10
4.8.5.1	Interconnecting leads and cables	10
4.8.5.2	Input power leads	10
4.8.6	Electrical and mechanical interfaces	11

MIL-STD-462D

CONTENTS

<u>PARAGRAPH</u>		<u>PAGE</u>
4.9	Operation of EUT	11
4.9.1	Operating frequencies for tunable RF equipment	11
4.9.2	Operating frequencies for spread spectrum equipment	11
4.9.3	Susceptibility monitoring	12
4.10	Use of measurement equipment	12
4.10.1	Detector	12
4.10.2	Computer-controlled receivers	12
4.10.3	Emission testing	12
4.10.3.1	Bandwidths	12
4.10.3.2	Emission identification	13
4.10.3.3	Frequency scanning	13
4.10.3.4	Emission data presentation	13
4.10.4	Susceptibility testing	13
4.10.4.1	Frequency scanning	14
4.10.4.2	Modulation of susceptibility signals	14
4.10.4.3	Thresholds of susceptibility	14
4.11	Calibration of measuring equipment and antennas	15
4.11.1	Measurement system test	15
4.12	Antenna factors	15
5.	MEASUREMENT PROCEDURES	16
CE101	CONDUCTED EMISSIONS, POWER LEADS, 30 Hz TO 10 kHz	25
CE102	CONDUCTED EMISSIONS, POWER LEADS, 10 kHz TO 10 MHz	31
CE106	CONDUCTED EMISSIONS, ANTENNA TERMINAL, 10 kHz TO 40 GHz	37
CS101	CONDUCTED SUSCEPTIBILITY, POWER LEADS, 30 Hz TO 50 kHz	45
CS103	CONDUCTED SUSCEPTIBILITY, ANTENNA PORT, INTERMODULATION, 15 kHz to 10 GHz	53
CS104	CONDUCTED SUSCEPTIBILITY, ANTENNA PORT, REJECTION OF UNDESIRE SIGNALS, 30 kHz to 20 GHz	55
CS105	CONDUCTED SUSCEPTIBILITY, ANTENNA PORT, CROSS MODULATION, 30 kHz to 20 GHz	57
CS109	CONDUCTED SUSCEPTIBILITY, STRUCTURE CURRENT, 60 Hz TO 100 kHz	59
CS114	CONDUCTED SUSCEPTIBILITY, BULK CABLE INJECTION, 10 kHz TO 400 MHz	63
CS115	CONDUCTED SUSCEPTIBILITY, BULK CABLE INJECTION, IMPULSE EXCITATION	69

MIL-STD-462D

CONTENTS

<u>TEST METHOD</u>	<u>PAGE</u>
CS116	CONDUCTED SUSCEPTIBILITY, DAMPED SINUSOIDAL TRANSIENTS, CABLES AND POWER LEADS, 10 kHz TO 100 MHz 75
RE101	RADIATED EMISSIONS, MAGNETIC FIELD, 30 Hz TO 100 kHz 83
RE102	RADIATED EMISSIONS, ELECTRIC FIELD, 10 kHz TO 18 GHz 89
RE103	RADIATED EMISSIONS, ANTENNA SPURIOUS AND HARMONIC OUTPUTS, 10 kHz TO 40 GHz 97
RS101	RADIATED SUSCEPTIBILITY, MAGNETIC FIELD, 30 Hz TO 100 kHz 103
RS103	RADIATED SUSCEPTIBILITY, ELECTRIC FIELD, 10 kHz TO 40 GHz 109
RS105	RADIATED SUSCEPTIBILITY, TRANSIENT ELECTROMAGNETIC FIELD 119

TABLE

I	Absorption at normal incidence 7
II	Bandwidth and measurement time 13
III	Susceptibility scanning 14
IV	Index of measurement procedures 17

FIGURE

1	RF absorber loading diagram 18
2	General test setup 19
3	Test setup for non-conductive surface mounted EUT
4	Test setup for free standing EUT, multiple EUT, shielded enclosure 21
5	Test setup for free standing EUT 22
6	LISN schematic 23
7	LISN impedance 24

APPENDIX

A	MIL-STD-462D Application Guide A-1
---	--

1. SCOPE

1.1 Purpose. This standard establishes general techniques for use in the measurement and determination of the electromagnetic emission and susceptibility characteristics of electronic, electrical, and electromechanical equipment and subsystems designed or procured for use by activities and agencies of the Department of Defense.

1.2 Application. The testing techniques of this standard are used to obtain data for determination of compliance with the specified MIL-STD-461 requirements. The test methods contained in this document shall be adapted by the testing activity for each application. The adapted test methods shall be documented in the Electromagnetic Interference Test Procedures (EMITP) required by MIL-STD-461.

1.3 Emission and susceptibility designations. The test methods contained in this standard are designated in accordance with an alpha-numeric coding system. Each method is identified by a two letter combination followed by a three digit number. The number is for reference purposes only. The meaning of the individual letters are as follows:

C = Conducted
R = Radiated
E = Emissions
S = Susceptibility

- a. Conducted emissions tests are designated by "CE---."
- b. Radiated emissions tests are designated by "RE---."
- c. Conducted susceptibility tests are designated by "CS---."
- d. Radiated susceptibility test are designated by "RS---."
- e. "----" = numerical order of test from 101 to 199.

2. APPLICABLE DOCUMENTS

2.1 Government documents.

2.1.1 Specifications, standards, and handbooks. The following specifications, standards, and handbooks form a part of this document to the extent specified herein. Unless otherwise specified, the issues of these documents are those listed in the issue of the Department of Defense Index of Specifications and Standards (DODISS) and supplement thereto, cited in the solicitation.

STANDARDS

MILITARY

MIL-STD-461	-	Requirements for the Control of Electromagnetic Interference Emissions and Susceptibility
MIL-STD-45662	-	Calibration Systems Requirements

(Copies of federal and military specifications, standards, and handbooks are available from the Naval Publications and Forms Center, ATTN: NPODS, 700 Robbins Avenue, Philadelphia, PA 19111-5093.)

2.1.2 Other Government documents, drawings, and publications. The following other Government documents, drawings, and publications form a part of this document to the extent specified herein. Unless otherwise specified, the issues are those cited in the solicitation.

DODISS - Department of Defense Index of Specifications and Standards

(Copies of the DODISS are available on a yearly subscription basis either from the Government Printing Office for hard copy, or microfiche copies are available from the Director, Navy Publications and Printing Service Office, 700 Robbins Avenue, Philadelphia, PA 19111-5093.)

2.2 Non-Government publications. The following documents form a part of this document to the extent specified herein. Unless otherwise specified, the issues of the documents which are DOD adopted are those listed in the issue of the DODISS cited in the solicitation. Unless otherwise specified, the issues of

MIL-STD-462D

documents not listed in the DODISS are the issues of the documents cited in the solicitation.

AMERICAN NATIONAL STANDARDS INSTITUTE (ANSI)

- ANSI/IEEE 268 - Metric Practice. (DOD adopted)
- ANSI C63.2 - Standard for Instrumentation-Electromagnetic Noise and Field Strength, 10 kHz to 40 GHz - Specifications
- ANSI C63.4 - Standard for Electromagnetic Compatibility - Radio-Noise Emissions from Low Voltage Electrical and Electronic Equipment in the Range of 9 kHz to 40 GHz - Methods of Measurement.
- ANSI C63.14 - Standard Dictionary for Technologies of Electromagnetic Compatibility (EMC), Electromagnetic Pulse (EMP), and Electrostatic Discharge (ESD).
- ANSI C95.1 - Standard for Safety Levels with Respect to Human Exposure to Radio Frequency Electromagnetic Fields (300 kHz - 100 GHz).

(Application for copies should be addressed to the IEEE Service Center, 445 Hoes Lane, PO Box 1331, Piscataway, NJ 08855-1331.)

SOCIETY OF AUTOMOTIVE ENGINEERS (SAE)

- ARP 958 - Electromagnetic Interference Measurement Antennas; Standard Calibration Requirements and Methods

(Application for copies should be addressed to the Society of Automotive Engineers, Inc., 400 Commonwealth Drive, Warrendale, PA 15096.)

AMERICAN SOCIETY FOR TESTING AND MATERIALS (ASTM)

- ASTM E 380 - Standard for Metric Practice. (DOD adopted)

MIL-STD-462D

(Application for copies should be addressed to the American Society for Testing and Materials, 1916 Race Street, Philadelphia, PA 19103-1187.)

3. DEFINITIONS

3.1 General. The terms used in this standard are defined in ANSI C63.14. In addition, the following definitions are applicable for the purpose of this standard.

3.2 Acronyms used in this standard.

- a. BIT - Built-in Test
- b. EMI - Electromagnetic Interference
- c. EMITP - Electromagnetic Interference Test Procedures
- d. EMITR - Electromagnetic Interference Test Report
- e. ERP - Effective Radiated Power
- f. EUT - Equipment Under Test
- g. LISN - Line Impedance Stabilization Network
- h. RF - Radio Frequency
- i. RMS - Root Mean Square
- j. TEM - Transverse Electromagnetic
- k. TPD - Terminal Protection Device

3.3 Metric units. Metric units are a system of basic measures which are defined by the International System of Units based on "Le System International d'Unites (SI)", of the International Bureau of Weights and Measures. These units are described in ASTM E 380 and ANSI/IEEE 268.

3.4 Test setup boundary. The test setup boundary includes all enclosures of the Equipment Under Test (EUT) and the 2 meters of exposed interconnecting leads (except for leads which are shorter in the actual installation) and power leads required by the general section of this standard.

4. REQUIREMENTS

4.1 General. General requirements related to test methods, test facilities, and equipment are as stated below. Any approved exceptions or deviations from these general test requirements shall be documented in the EMITP required by MIL-STD-461.

4.1.1 Measurement tolerances. Unless otherwise stated for a particular measurement, the tolerance shall be as follows:

- a. Distance: $\pm 5\%$
- b. Frequency: $\pm 2\%$
- c. Amplitude, measurement receiver: ± 2 dB
- d. Amplitude, measurement system (includes measurement receivers, transducers, cables, and so forth): ± 3 dB
- e. Time (waveforms): $\pm 5\%$

4.2 Shielded enclosures. To prevent interaction between the EUT and the outside environment, shielded enclosures will usually be required for testing. These enclosures prevent external environment signals from contaminating emission measurements and susceptibility test signals from interfering with electrical and electronic items in the vicinity of the test facility. Shielded enclosures must have adequate attenuation such that the ambient requirements of paragraph 4.4 are satisfied. The enclosures must be sufficiently large such that the EUT arrangement requirements of paragraph 4.8 and antenna positioning requirements described in the individual test methods are satisfied.

4.2.1 Radio Frequency (RF) absorber material. RF absorber material (carbon impregnated foam pyramids, ferrite tiles, and so forth) shall be used when performing electric field radiated emissions or radiated susceptibility testing inside a shielded enclosure to reduce reflections of electromagnetic energy and to improve accuracy and repeatability. The RF absorber shall be placed above, behind, and on both sides of the EUT, and behind the radiating or receiving antenna as shown in Figure 1. Minimum performance of the material shall be as specified in Table I. The manufacturer's certification of their RF absorber material (basic material only, not installed) is acceptable.

TABLE I. Absorption at normal incidence.

Frequency	Minimum absorption
80 MHz - 250 MHz	6 dB
above 250 MHz	10 dB

4.3 Other test sites. If other test sites are used, the ambient requirements of paragraph 4.4 shall be met.

4.4 Ambient electromagnetic level. During testing, the ambient electromagnetic level measured with the EUT de-energized and all auxiliary equipment turned on shall be at least 6 dB below the allowable specified limits when the tests are performed in a shielded enclosure. Ambient conducted levels on power leads shall be measured with the leads disconnected from the EUT and connected to a resistive load which draws the same rated current as the EUT. When tests are performed in a shielded enclosure and the EUT is in compliance with MIL-STD-461 limits, the ambient profile need not be recorded in the Electromagnetic Interference Test Report (EMITR). When measurements are made outside a shielded enclosure, the tests shall be performed during times and conditions when the ambient is at its lowest level. The ambient shall be recorded in the EMITR required by MIL-STD-461 and shall not compromise the test results.

4.5 Ground plane. The EUT shall be installed on a ground plane that simulates the actual installation. If the actual installation is unknown or multiple installations are expected, then a metallic ground plane shall be used. Unless otherwise specified below, ground planes shall be 2.25 square meters or larger in area with the smaller side no less than 76 centimeters. When a ground plane is not present in the EUT installation, the EUT shall be placed on a non-conductive surface.

4.5.1 Metallic ground plane. When the EUT is installed on a metallic ground plane, the ground plane shall have a surface resistance no greater than 0.1 milliohms per square. The DC resistance between metallic ground planes and the shielded enclosure shall be 2.5 milliohms or less. The metallic ground planes shown in Figures 2 through 5 shall be electrically bonded to the floor or wall of the basic shielded room structure at least once every 1 meter. The metallic bond straps shall be solid and maintain a five-to-one ratio or less in length to width. Metallic ground planes used outside a shielded enclosure shall be at least 2 meters by 2 meters and extend at least 0.5 meter beyond the test setup boundary.

4.5.2 Composite ground plane. When the EUT is installed on a conductive composite ground plane, the surface resistivity of the typical installation shall be used. Composite ground planes shall be electrically bonded to the enclosure with means suitable to the material.

4.6 Power source impedance. The impedance of power sources providing input power to the EUT shall be controlled by Line Impedance Stabilization Networks (LISNs) for all measurement procedures of this document unless otherwise stated in a particular test method. The LISNs shall be located at the power source end of the exposed length of power leads specified in paragraph 4.8.5.2. The LISN circuit shall be in accordance with the schematic shown in Figure 6. The LISN impedance characteristics shall be in accordance with Figure 7. The LISN impedance shall be measured at least annually under the following conditions:

- a. The impedance shall be measured between the power output lead on the load side of the LISN and the metal enclosure of the LISN.
- b. The signal output port of the LISN shall be terminated in fifty ohms.
- c. The power input terminal on the power source side of the LISN shall be unterminated.

The impedance measurement results shall be provided in the EMITR required by MIL-STD-461.

4.7 General test precautions.

4.7.1 Accessory equipment. Accessory equipment used in conjunction with measurement receivers shall not degrade measurement integrity.

4.7.2 Excess personnel and equipment. The test area shall be kept free of unnecessary personnel, equipment, cable racks, and desks. Only the equipment essential to the test being performed shall be in the test area or enclosure. Only personnel actively involved in the test shall be permitted in the enclosure.

4.7.3 Overload precautions. Measurement receivers and transducers are subject to overload, especially receivers without preselectors and active transducers. Periodic checks shall be performed to assure that an overload condition does not exist.

Instrumentation changes shall be implemented to correct any overload condition.

4.7.4 RF hazards. Some tests in this standard will result in electromagnetic fields which are potentially dangerous to personnel. The permissible exposure levels in ANSI C95.1 shall not be exceeded in areas where personnel are present. Safety procedures and devices shall be used to prevent accidental exposure of personnel to RF hazards.

4.7.5 Shock hazard. Some of the tests require potentially hazardous voltages to be present. Extreme caution must be taken by all personnel to assure that all safety precautions are observed.

4.7.6 Federal Communications Commission (FCC) restrictions. Some of the tests require high level signals to be generated that could interfere with normal FCC approved frequency assignments. All such testing should be conducted in a shielded enclosure. Some open site testing may be feasible if prior FCC coordination is obtained.

4.8 EUT test configurations. The EUT shall be configured as shown in the general test setups of Figures 1 through 5 as applicable. These setups shall be maintained during all testing unless other direction is given for a particular test method.

4.8.1 Bonding of EUT. Only the provisions included in the design of the EUT shall be used to bond units such as equipment case and mounting bases together, or to the ground plane. When bonding straps are required to complete the test setup, they shall be identical to those specified in the installation drawings.

4.8.2 Shock and vibration isolators. EUTs shall be secured to mounting bases having shock or vibration isolators if such mounting bases are used in the installation. The bonding straps furnished with the mounting base shall be connected to the ground plane. When mounting bases do not have bonding straps, bonding straps shall not be used in the test setup.

4.8.3 Wire grounds. When external terminals, connector pins, or equipment grounding conductors in power cables are available for ground connections and are used in the actual installation, they shall be connected to the ground plane after a 2 meter exposed length (see 4.8.5). Shorter lengths shall be used if they are specified in the installation instructions.

4.8.4 Orientation of EUTs. EUTs shall be oriented such that surfaces which produce maximum radiated emissions and respond most readily to radiated signals face the measurement antennas. Bench mounted EUTs shall be located 10 ± 2 centimeters from the front edge of the ground plane subject to allowances for providing adequate room for cable arrangement as specified below.

4.8.5 Construction and arrangement of EUT cables. Electrical cable assemblies shall simulate actual installation and usage. Shielded cables or shielded leads (including power leads and wire grounds) within cables shall be used only if they have been specified in installation drawings. Cables shall be checked against installation requirements to verify proper construction techniques such as use of twisted pairs, shielding, and shield terminations. Details on the cable construction used for testing shall be included in the EMITP.

4.8.5.1 Interconnecting leads and cables. Individual leads shall be grouped into cables in the same manner as in the actual installation. Total interconnecting cable lengths in the setup shall be the same as in the actual platform installation. If a cable is longer than 10 meters, at least 10 meters shall be included. When cable lengths are not specified for the installation, cables shall be sufficiently long to satisfy the conditions specified below. At least 2 meters (except for cables which are shorter in the actual installation) of each interconnecting cable shall be run parallel to the front boundary of the setup. Remaining cable lengths shall be routed to the back of the setup and shall be placed in a zig-zagged arrangement. When the setup includes more than one cable, individual cables shall be separated by 2 centimeters measured from their outer circumference. For bench top setups using ground planes, the cable closest to the front boundary shall be placed 10 centimeters from the front edge of the ground plane. All cables shall be supported 5 centimeters above the ground plane.

4.8.5.2 Input power leads. Two meters of input power leads (including returns) shall be routed parallel to the front edge of the setup in the same manner as the interconnecting leads. The power leads shall be connected to the LISNs (see 4.6). Power leads that are part of an interconnecting cable shall be separated out at the EUT connector and routed to the LISNs. After the 2 meter exposed length, the power leads shall be terminated at the LISNs in as short a distance as possible. The total length of power lead from the EUT electrical connector to the LISNs shall not exceed 2.5 meters. All power leads shall be supported 5 centimeters above the ground plane. If the power

leads are twisted in the actual installation, they shall be twisted up to the LISNs.

4.8.6 Electrical and mechanical interfaces. All electrical input and output interfaces shall be terminated with either the actual equipment from the platform installation or loads which simulate the electrical properties (impedance, grounding, balance, and so forth) present in the actual installation. Signal inputs shall be applied to all applicable electrical interfaces to exercise EUT circuitry. EUTs with mechanical outputs shall be suitably loaded. When variable electrical or mechanical loading is present in the actual installation, testing shall be performed under expected worst case conditions. When active electrical loading (such as a test set) is used, precautions shall be taken to insure the active load meets the ambient requirements of paragraph 4.4 when connected to the setup, and that the active load does not respond to susceptibility signals. Antenna ports on the EUT shall be terminated with shielded, matched loads.

4.9 Operation of EUT. During emission measurements, the EUT shall be placed in an operating mode which produces maximum emissions. During susceptibility testing, the EUT shall be placed in its most susceptible operating mode. For EUTs with several available modes (including software controlled operational modes), a sufficient number of modes shall be tested for emissions and susceptibility such that all circuitry is evaluated.

4.9.1 Operating frequencies for tunable RF equipment. Measurements shall be performed with the EUT tuned to not less than three frequencies within each tuning band, tuning unit, or range of fixed channels, consisting of one mid-band frequency and a frequency within ± 5 percent from each end of each band or range of channels.

4.9.2 Operating frequencies for spread spectrum equipment. Operating frequency requirements for two major types of spread spectrum equipment shall be as follows:

- a. Frequency hopping. Measurements shall be performed with the EUT utilizing a hop set which contains 30% of the total possible frequencies. The hop set shall be divided equally into three segments at the low, mid, and high end of the EUT's operational frequency range.
- b. Direct sequence. Measurements shall be performed with the EUT processing data at the highest possible data transfer rate.

4.9.3 Susceptibility monitoring. The EUT shall be monitored during susceptibility testing for indications of degradation or malfunction. This monitoring is normally accomplished through the use of built-in-test (BIT), visual displays, aural outputs, and other measurements of signal outputs and interfaces. Monitoring of EUT performance through installation of special circuitry in the EUT is permissible; however, these modifications shall not influence test results.

4.10 Use of measurement equipment. Measurement equipment shall be as specified in the individual test methods of this standard. Any frequency selective measurement receiver may be used for performing the testing described in this standard provided that the receiver characteristics (that is, sensitivity, selection of bandwidths, detector functions, dynamic range, and frequency of operation) meet the constraints specified in this standard and are sufficient to demonstrate compliance with the applicable limits of MIL-STD-461. Typical instrumentation characteristics may be found in ANSI C63.2.

4.10.1 Detector. A peak detector shall be used for all frequency domain emission and susceptibility measurements. This device detects the peak value of the modulation envelope in the receiver bandpass. Measurement receivers are calibrated in terms of an equivalent Root Mean Square (RMS) value of a sine wave that produces the same peak value. When other measurement devices such as oscilloscopes, non-selective voltmeters, or broadband field strength sensors are used for susceptibility testing, correction factors shall be applied for test signals to adjust the reading to equivalent RMS values under the peak of the modulation envelope.

4.10.2 Computer-controlled receivers. A description of the operations being directed by software for computer-controlled receivers shall be included in the EMITP required by MIL-STD-461. Verification techniques used to demonstrate proper performance of the software shall also be included.

4.10.3 Emission testing.

4.10.3.1 Bandwidths. The measurement receiver bandwidths listed in Table II shall be used for emission testing. These bandwidths are specified at the 6 dB down points for the overall selectivity curve of the receivers. Video filtering shall not be used to bandwidth limit the receiver response. If a controlled video bandwidth is available on the measurement receiver, it shall be set to its greatest value. Larger bandwidths may be used; however, they may result in higher measured emission

levels. NO BANDWIDTH CORRECTION FACTORS SHALL BE APPLIED TO TEST DATA DUE TO THE USE OF LARGER BANDWIDTHS.

TABLE II. Bandwidth and measurement time.

Frequency Range	6 dB Bandwidth	Dwell Time	Minimum Measurement Time Analog Measurement Receiver
30 Hz - 1 kHz	10 Hz	0.15 sec	0.015 sec/Hz
1 kHz - 10 kHz	100 Hz	0.015 sec	0.15 sec/kHz
10 kHz - 250 kHz	1 kHz	0.015 sec	0.015 sec/kHz
250 kHz - 30 MHz	10 kHz	0.015 sec	1.5 sec/MHz
30 MHz - 1 GHz	100 kHz	0.015 sec	0.15 sec/MHz
Above 1 GHz	1 MHz	0.015 sec	15 sec/GHz

4.10.3.2 Emission identification. All emissions regardless of characteristics shall be measured with the measurement receiver bandwidths specified in Table II and compared against the limits in MIL-STD-461. Identification of emissions with regard to narrowband or broadband categorization is not applicable.

4.10.3.3 Frequency scanning. For emission measurements, the entire frequency range for each applicable test shall be scanned. Minimum measurement time for analog measurement receivers during emission testing shall be as specified in Table II. Synthesized measurement receivers shall step in one-half bandwidth increments or less, and the measurement dwell time shall be as specified in Table II.

4.10.3.4 Emission data presentation. Amplitude versus frequency profiles of emission data shall be automatically and continuously plotted. The applicable limit shall be displayed on the plot. Manually gathered data is not acceptable except for plot verification. The plotted data for emissions measurements shall provide a minimum frequency resolution of 1% or twice the measurement receiver bandwidth, whichever is less stringent, and minimum amplitude resolution of 1 dB. The above resolution requirements shall be maintained in the reported results of the EMITR.

4.10.4 Susceptibility testing.

4.10.4.1 Frequency scanning. For susceptibility measurements, the entire frequency range for each applicable test shall be scanned. For swept frequency susceptibility testing, frequency scan rates and frequency step sizes of signal sources shall not exceed the values listed in Table III. The rates and step sizes are specified in terms of a multiplier of the tuned frequency (f_0) of the signal source. Analog scans refer to signal sources which are continuously tuned. Stepped scans refer to signal sources which are sequentially tuned to discrete frequencies. Stepped scans shall dwell at each tuned frequency for a minimum of 1 second. Scan rates and step sizes shall be decreased when necessary to permit observation of a response.

TABLE III. Susceptibility scanning.

Frequency Range	Analog Scans Maximum Scan Rates	Stepped Scans Maximum Step Size
30 Hz - 1 MHz	$0.02 f_0/\text{sec}$	$0.01 f_0$
1 MHz - 30 MHz	$0.01 f_0/\text{sec}$	$0.005 f_0$
30 MHz - 1 GHz	$0.005 f_0/\text{sec}$	$0.0025 f_0$
1 GHz - 8 GHz	$0.002 f_0/\text{sec}$	$0.001 f_0$
8 GHz - 40 GHz	$0.001 f_0/\text{sec}$	$0.0005 f_0$

4.10.4.2 Modulation of susceptibility signals. Susceptibility test signals above 10 kHz shall be pulse modulated at a 1 kHz rate with a 50% duty cycle unless otherwise specified in an individual test method of this standard.

4.10.4.3 Thresholds of susceptibility. When susceptibility indications are noted in EUT operation, a threshold level shall be determined where the susceptible condition is no longer present. Thresholds of susceptibility shall be determined as follows:

- a. When a susceptibility condition is detected, reduce the interference signal until the EUT recovers.
- b. Reduce the interference signal by an additional 6 dB.
- c. Gradually increase the interference signal until the susceptibility condition reoccurs. The resulting level is the threshold of susceptibility.

- d. Record this level, frequency range of occurrence, frequency and level of greatest susceptibility, and other test parameters, as applicable.

4.11 Calibration of measuring equipment and antennas. Test equipment and accessories required for measurement in accordance with this standard shall be calibrated under an approved program in accordance with MIL-STD-45662. In particular, measurement antennas, current probes, field sensors, and other devices used in the measurement loop shall be calibrated at least every 2 years unless otherwise specified by the procuring activity, or when damage is apparent. Antenna factors and current probe transfer impedances shall be determined on an individual basis for each device.

4.11.1 Measurement system test. At the start of each emission test, the complete test system (including measurement receivers, cables, attenuators, couplers, and so forth) shall be verified by injecting a known signal, as stated in the individual test method, while monitoring system output for the proper indication.

4.12 Antenna factors. Factors for electric field test antennas shall be determined in accordance with SAE ARP-958.

5. MEASUREMENT PROCEDURES

This section contains the measurement procedures to be used in determining compliance with the emission and susceptibility requirements of MIL-STD-461. The test procedures are applicable for the entire specified frequency range; however, certain equipment or classes of equipment may not require testing throughout the complete measurement frequency range. These modifications are specified in MIL-STD-461. Table IV is an index of measurement procedures by method number and title.

TABLE IV. Index of measurement procedures.

Requirement	Description
CE101	Conducted Emissions, Power Leads, 30 Hz to 10 kHz
CE102	Conducted Emissions, Power Leads, 10 kHz to 10 MHz
CE106	Conducted Emissions, Antenna Terminal, 10 kHz to 40 GHz
CS101	Conducted Susceptibility, Power Leads, 30 Hz to 50 kHz
CS103	Conducted Susceptibility, Antenna Port, Intermodulation, 15 kHz to 10 GHz
CS104	Conducted Susceptibility, Antenna Port, Rejection of Undesired Signals, 30 Hz to 20 GHz
CS105	Conducted Susceptibility, Antenna Port, Cross-Modulation, 30 Hz to 20 GHz
CS109	Conducted Susceptibility, Structure Current, 60 Hz to 100 kHz
CS114	Conducted Susceptibility, Bulk Cable Injection, 10 kHz to 400 MHz
CS115	Conducted Susceptibility, Bulk Cable Injection, Impulse Excitation
CS116	Conducted Susceptibility, Damped Sinusoidal Transients, Cables and Power Leads, 10 kHz to 100 MHz
RE101	Radiated Emissions, Magnetic Field, 30 Hz to 100 kHz
RE102	Radiated Emissions, Electric Field, 10 kHz to 18 GHz
RE103	Radiated Emissions, Antenna Spurious and Harmonic Outputs, 10 kHz to 40 GHz
RS101	Radiated Susceptibility, Magnetic Field, 30 Hz to 100 kHz
RS103	Radiated Susceptibility, Electric Field, 10 kHz to 40 GHz
RS105	Radiated Susceptibility, Transient Electromagnetic Field

RF absorber placed above,
behind and on both sides of
test setup boundary, from
ceiling to ground plane

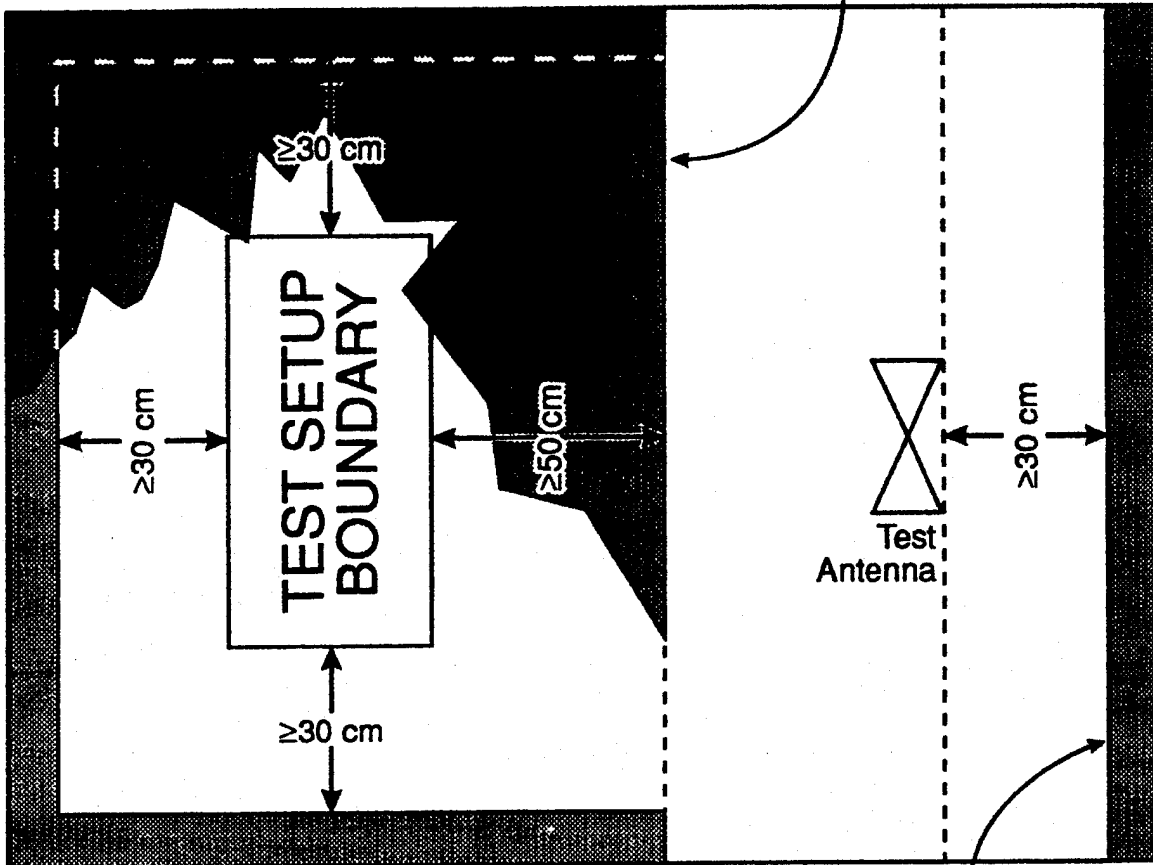

RF absorber placed
behind test antenna,
from ceiling to floor

FIGURE 1. RF absorber loading diagram.

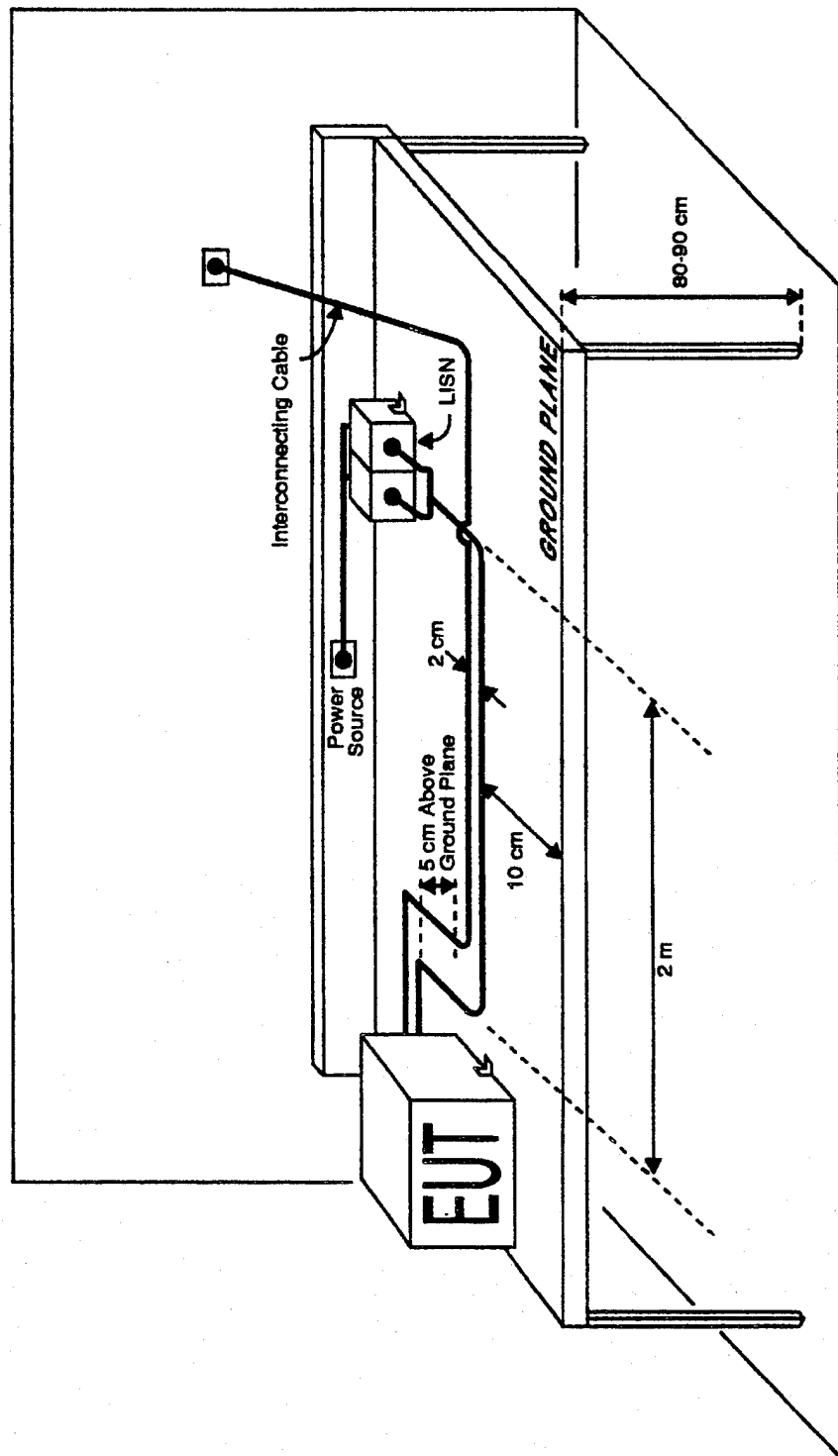

FIGURE 2. General test setup.

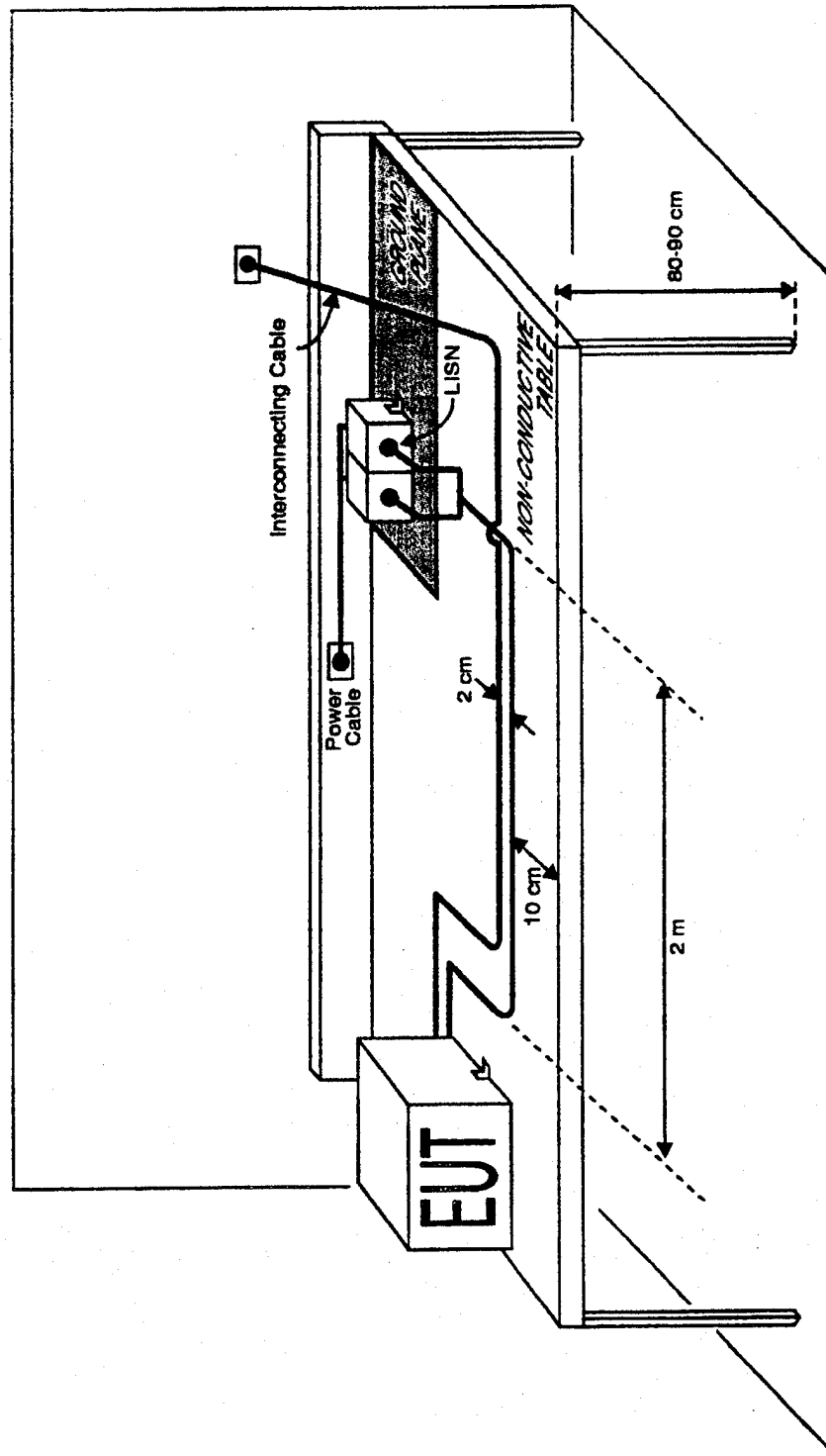

FIGURE 3. Test setup for non-conductive surface mounted EUT.

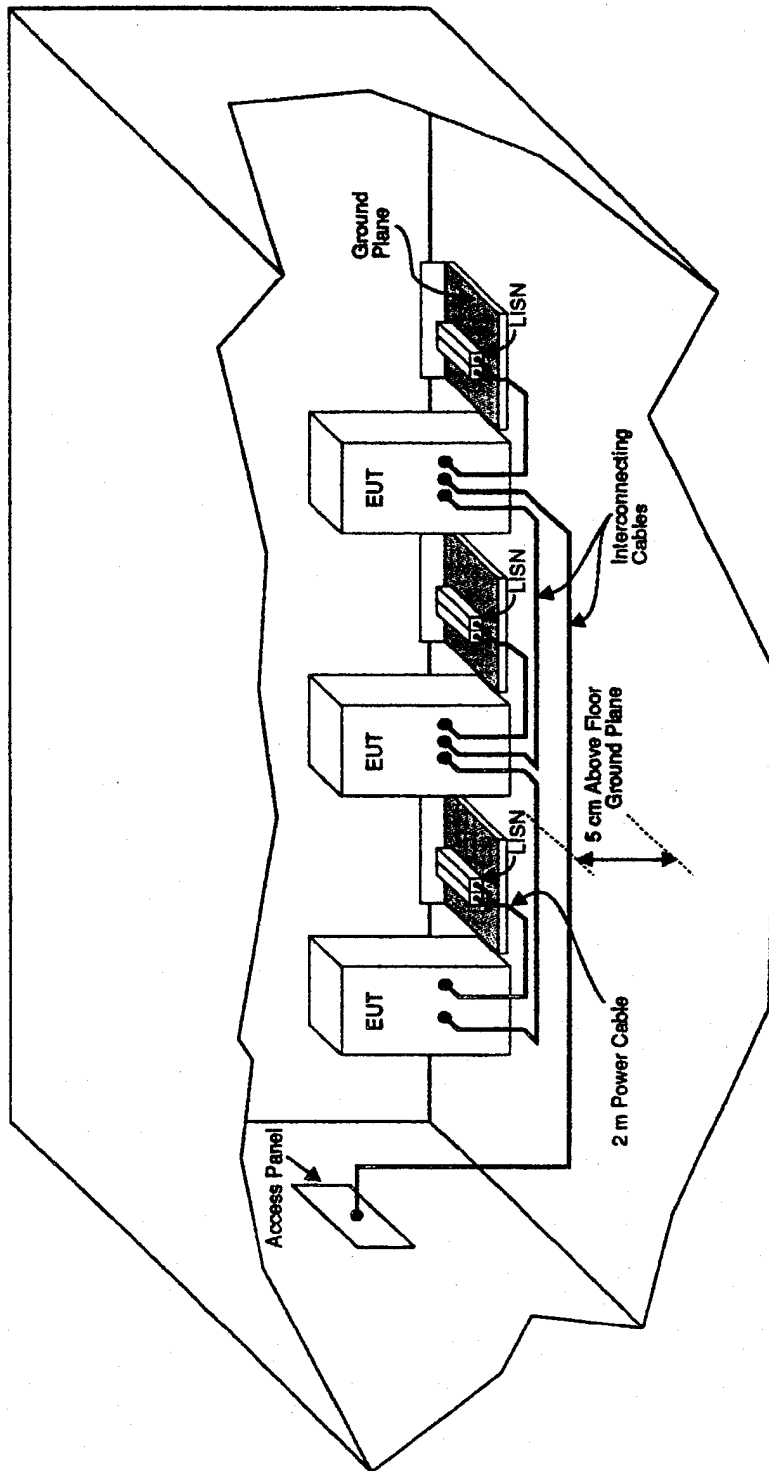

FIGURE 4. Test setup for free standing EUT, multiple EUT, shielded enclosure.

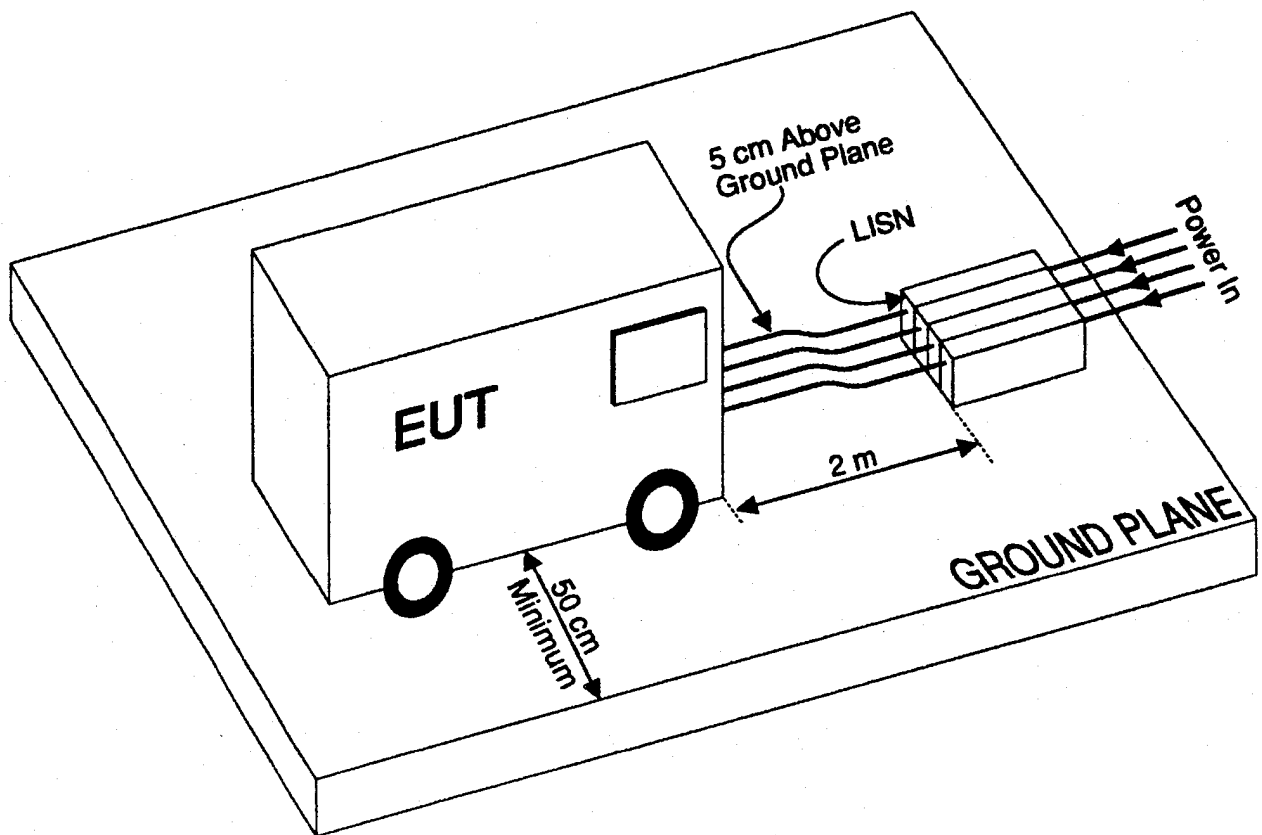

FIGURE 5. Test setup for free standing EUT.

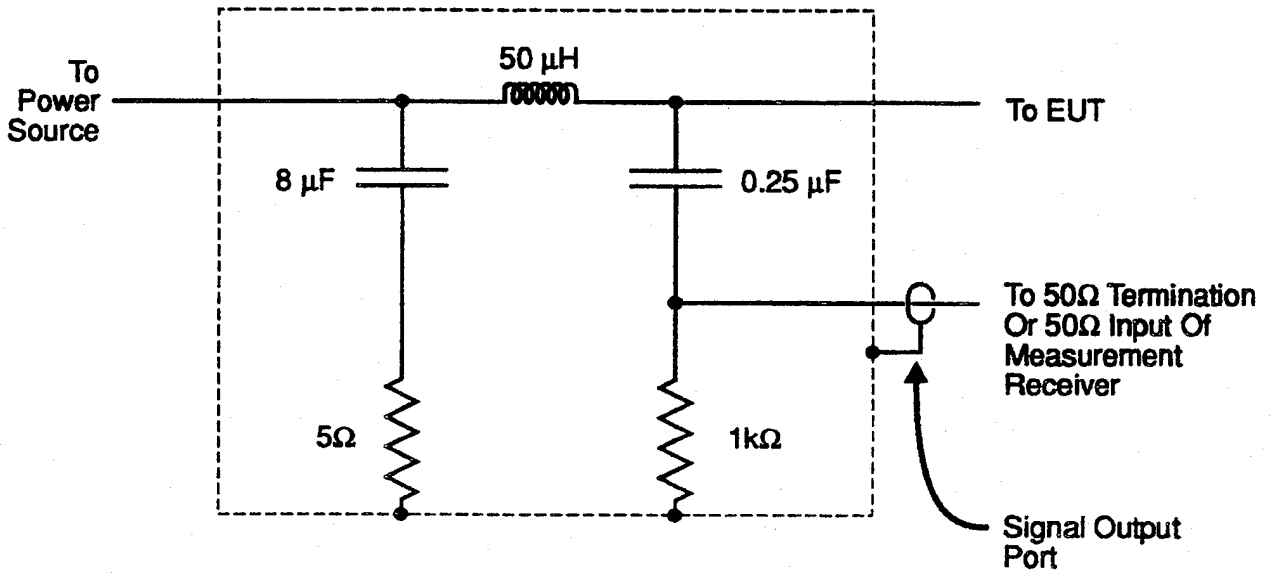

FIGURE 6. LISN schematic.

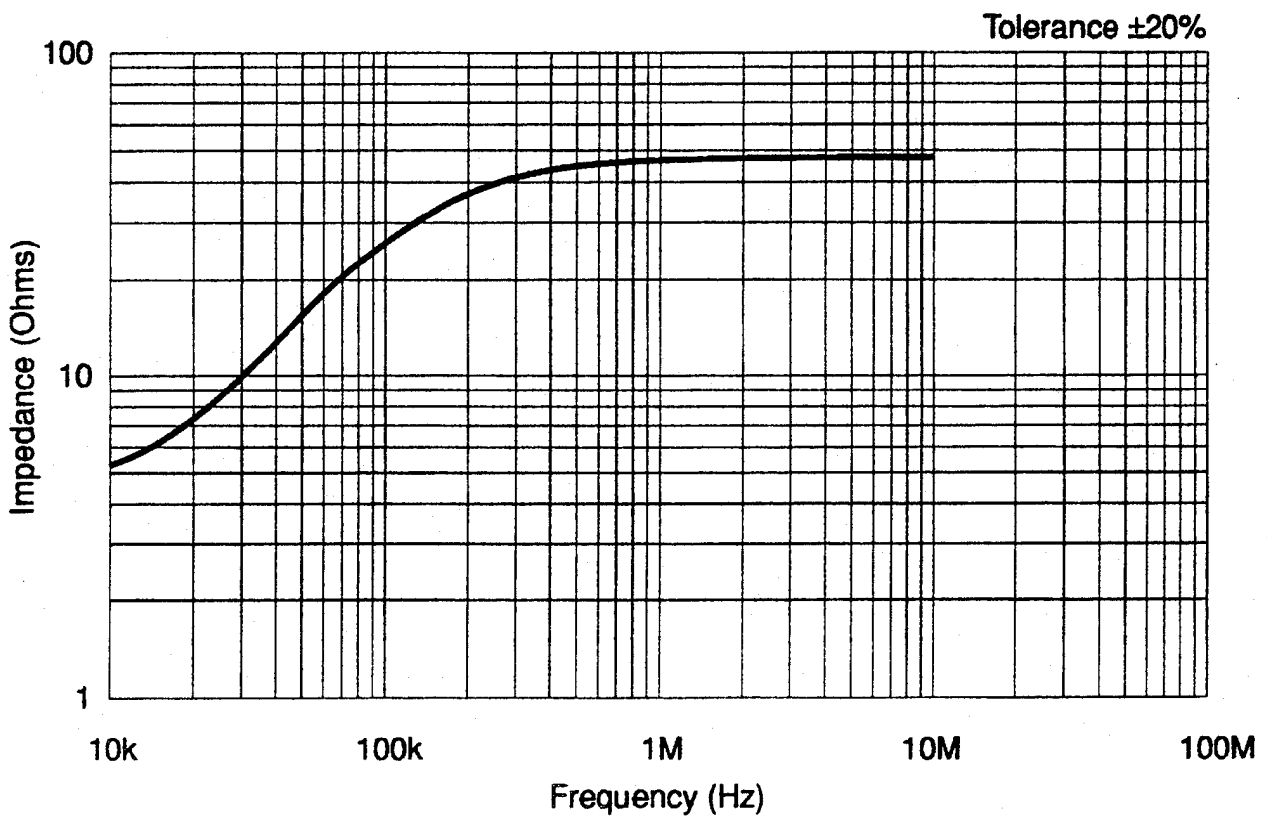

FIGURE 7. LISN impedance.

MIL-STD-462D

METHOD CE101

CONDUCTED EMISSIONS, POWER LEADS, 30 Hz TO 10 kHz

1. Purpose. This test method is used to verify that electromagnetic emissions from the EUT do not exceed the specified requirements for power input leads including returns.
2. Test Equipment. The test equipment shall be as follows:
 - a. Measurement receivers
 - b. Current probes
 - c. Signal generator
 - d. Data recording device
 - e. Oscilloscope
 - f. Resistor (R)
 - g. LISNs
3. Test Setup. The test setup shall be as follows:
 - a. Maintain a basic test setup for the EUT as shown and described in Figures 2 through 5 and paragraph 4.8 of the general section of this standard. The LISN may be removed or replaced with an alternative stabilization device when approved by the procuring activity.
 - b. Calibration. Configure the test setup for the measurement system check as shown in Figure CE101-1.
 - c. EUT testing.
 - (1) Configure the test setup for compliance testing of the EUT as shown in Figure CE101-2.
 - (2) Position the current probe 5 cm from the LISN.
4. Test Procedures. The test procedures shall be as follows:
 - a. Turn on the measurement equipment and allow a sufficient time for stabilization.

b. Calibration. Evaluate the overall measurement system from the current probe to the data output device.

- (1) Apply a calibrated signal level, which is 6 dB below the MIL-STD-461 limit at 1 kHz, 3 kHz, and 10 kHz, to the current probe.
- (2) Verify the current level, using the oscilloscope and load resistor; also, verify that the current waveform is sinusoidal.
- (3) Scan the measurement receiver for each frequency in the same manner as a normal data scan. Verify that the data recording device indicates a level within ± 3 dB of the injected level.
- (4) If readings are obtained which deviate by more than ± 3 dB, locate the source of the error and correct the deficiency prior to proceeding with the testing.

c. EUT testing. Determine the conducted emissions from the EUT input power leads, including returns.

- (1) Turn on the EUT and allow sufficient time for stabilization.
- (2) Select an appropriate lead for testing and clamp the current probe into position.
- (3) Scan the measurement receiver over the applicable frequency range, using the bandwidths and minimum measurement times specified in the general section of this standard.
- (4) Repeat 4c(3) for each power lead.

5. Data Presentation. Data presentation shall be as follows:

- a. Continuously and automatically plot amplitude versus frequency profiles on X-Y axis outputs. Manually gathered data is not acceptable except for plot verification.
- b. Display the applicable limit on each plot.
- c. Provide a minimum frequency resolution of 1% or twice the measurement receiver bandwidth, whichever is less

stringent, and a minimum amplitude resolution of 1 dB for each plot.

- d. Provide plots for both the measurement and system check portions of the procedure.

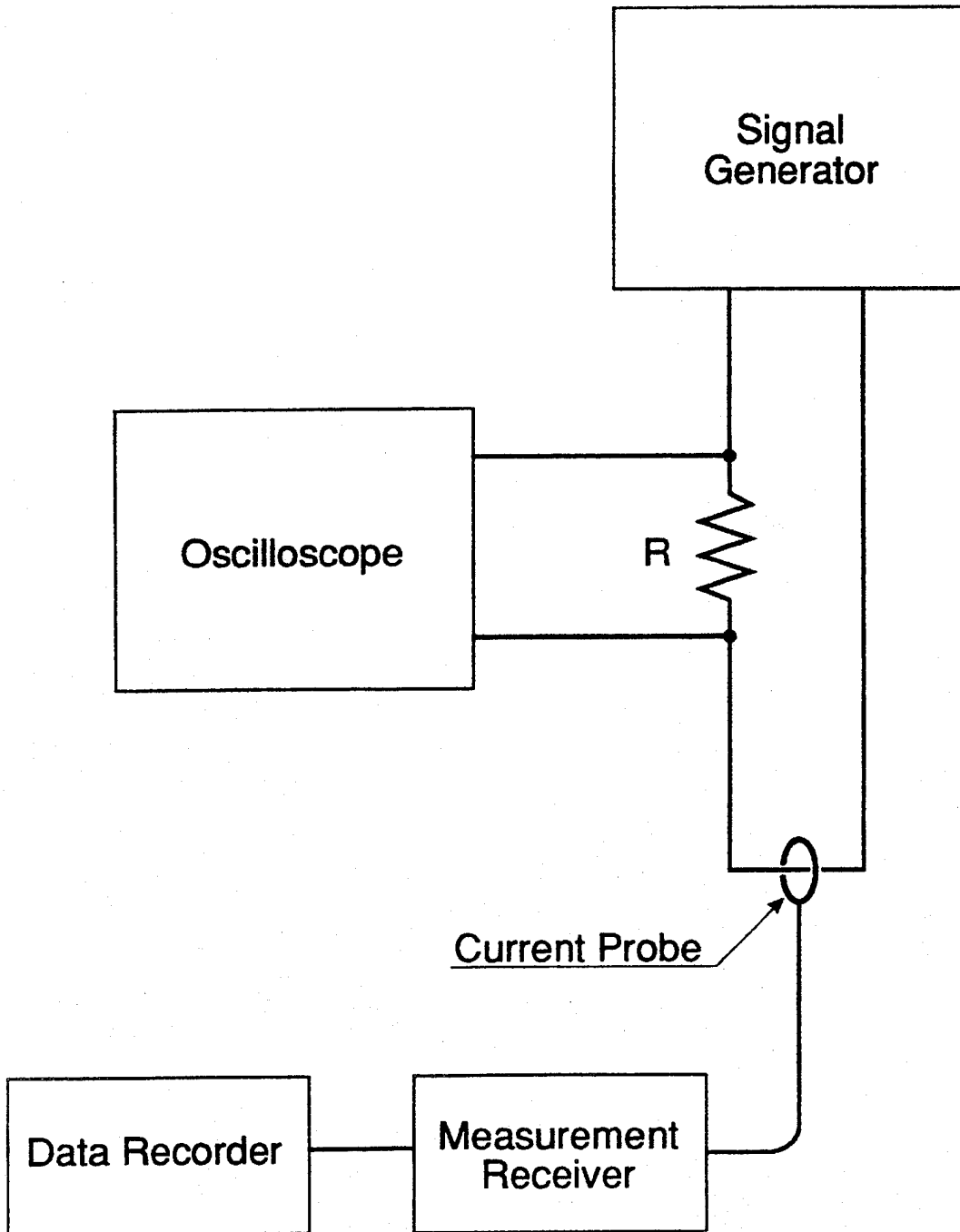

FIGURE CE101-1. Measurement system check setup.

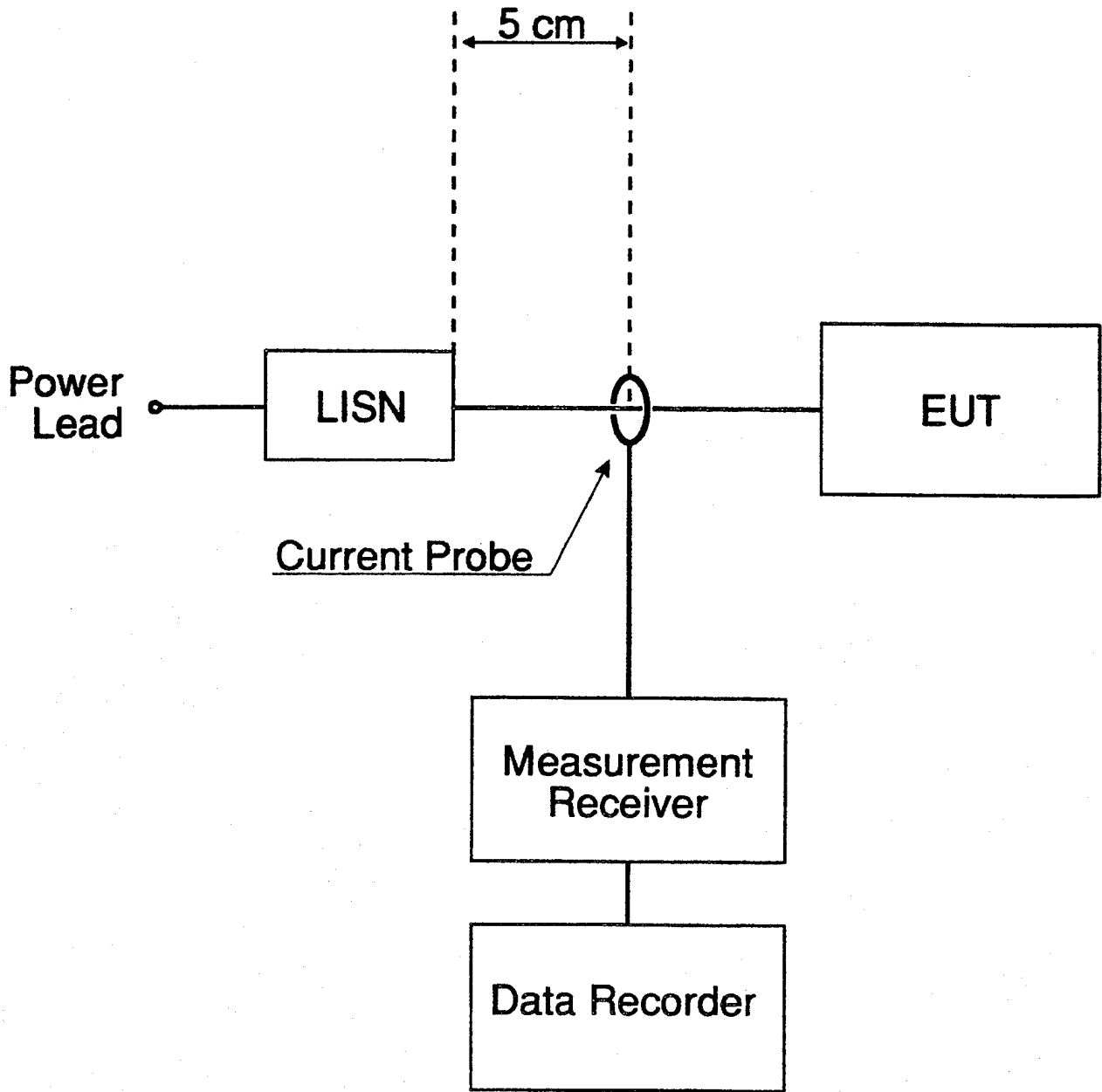

FIGURE CE101-2. Measurement setup.

MIL-STD-462D

METHOD CE102

CONDUCTED EMISSIONS, POWER LEADS, 10 kHz TO 10 MHz

1. Purpose. This test method is used to verify that electromagnetic emissions from the EUT do not exceed the specified requirements for power input leads, including returns.
2. Test Equipment. The test equipment shall be as follows:
 - a. Measurement receiver
 - b. Data recording device
 - c. Signal generator
 - d. Attenuator, 20 dB
 - e. Oscilloscope
 - f. LISNs
3. Test Setup. The test setup shall be as follows:
 - a. Maintain a basic test setup for the EUT as shown and described in Figures 2 through 5 and paragraph 4.8 of the general section of this standard.
 - b. Calibration.
 - (1) Configure the test setup for the measurement system check as shown in Figure CE102-1. Ensure that the EUT power source is turned off.
 - (2) Connect the measurement receiver to the 20 dB attenuator on the signal output port of the LISN.
 - c. EUT testing.
 - (1) Configure the test setup for compliance testing of the EUT as shown in Figure CE102-2.
 - (2) Connect the measurement receiver to the 20 dB attenuator on the signal output port of the LISN.
4. Test Procedures. The test procedures shall be as follows:

- a. Calibration. Perform the measurement system check using the measurement system check setup of Figure CE102-1.
 - (1) Turn on the measurement equipment and allow a sufficient time for stabilization.
 - (2) Apply a calibrated signal level, which is 6 dB below the MIL-STD-461 limit at 10 kHz, 100 kHz, 2 MHz and 10 MHz to the power output terminal of the LISN. Also, verify that the voltage waveform is sinusoidal.
 - (3) Scan the measurement receiver for each frequency in the same manner as a normal data scan. Verify that the measurement receiver indicates a level within ± 3 dB of the injected level. Correction factors shall be applied for the 20 dB attenuator and the voltage drop due to the LISN 0.25 microfarad coupling capacitor.
 - (4) If readings are obtained which deviate by more than ± 3 dB, locate the source of the error and correct the deficiency prior to proceeding with the testing.
 - b. EUT testing. Perform emission data scans using the measurement setup of Figure CE102-2.
 - (1) Turn on the EUT and allow a sufficient time for stabilization.
 - (2) Select an appropriate lead for testing.
 - (3) Scan the measurement receiver over the applicable frequency range, using the bandwidths and minimum measurement times in the general section of this standard.
 - (4) Repeat 4b(2) and 4b(3) for each power lead.
5. Data Presentation. Data presentation shall be as follows:
- a. Continuously and automatically plot amplitude versus frequency profiles on X-Y axis outputs. Manually gathered data is not acceptable except for plot verification.
 - b. Display the applicable limit on each plot.

- c. Provide a minimum frequency resolution of 1% or twice the measurement receiver bandwidth, whichever is less stringent, and a minimum amplitude resolution of 1 dB for each plot.
- d. Provide plots for both the measurement system check and measurement portions of the procedure.

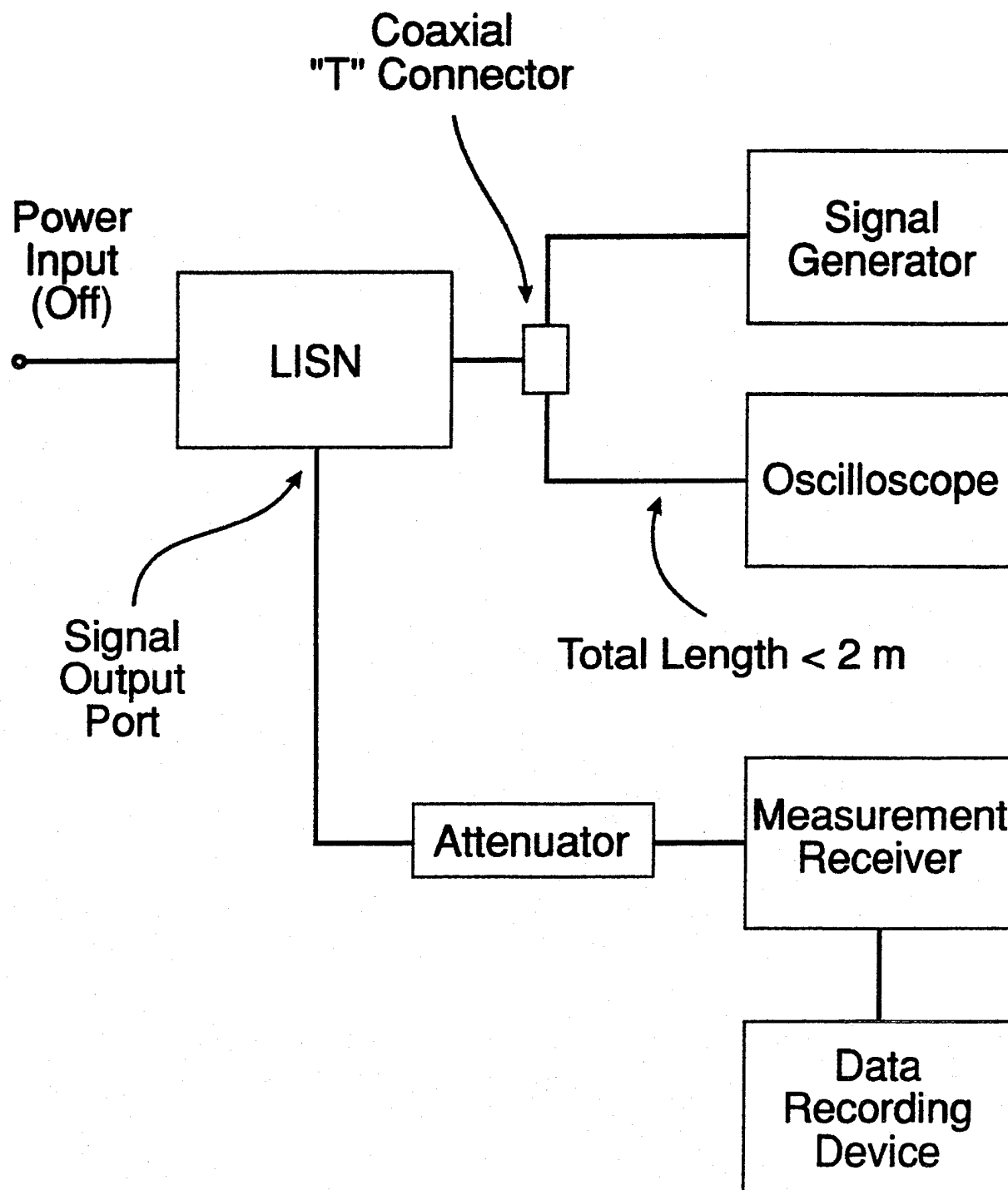

FIGURE CE102-1. Measurement system check setup.

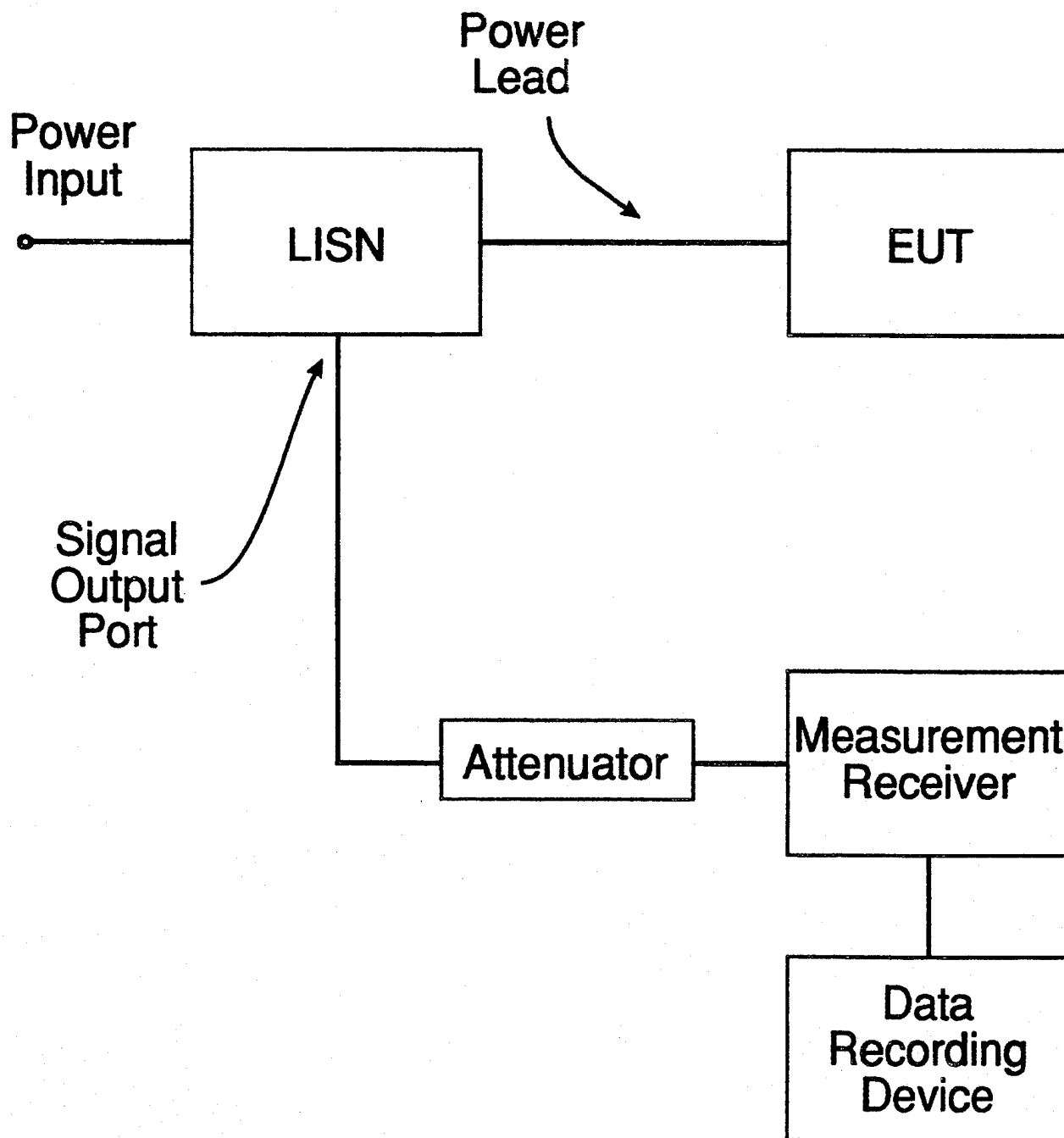

FIGURE CE102-2. Measurement setup.

METHOD CE106

CONDUCTED EMISSIONS, ANTENNA TERMINAL, 10 kHz TO 40 GHz

1. Purpose. This test method is used to verify that conducted emissions appearing at the antenna terminal of the EUT do not exceed specified requirements.
2. Test Equipment. The test equipment shall be as follows:
 - a. Measurement receiver
 - b. Attenuators
 - c. Rejection networks
 - d. Directional couplers
 - e. Dummy loads
 - f. Signal generators
 - g. Data recording device
3. Test Setup. It is not necessary to maintain the basic test setup for the EUT as shown and described in figures 2 through 5 and paragraph 4.8 of the general section of this standard. The test setup shall be as follows:
 - a. Calibration. Configure the test setup for the signal generator path shown in Figures CE106-1 through CE106-3 as applicable. The choice of figure CE106-1 or CE106-2 is dependent upon the power handling capability of the measuring equipment.
 - b. EUT Testing. Configure the test setup for the EUT path shown in Figures CE106-1 through CE106-3 as applicable. The choice of figure CE106-1 or CE106-2 is dependent upon the power handling capability of the measuring equipment.
4. Test Procedures.
 - 4.1 Transmitters (Transmit Mode). The test procedure shall be as follows:
 - a. Turn on the measurement equipment and allow a sufficient time for stabilization.

b. Calibration.

- (1) Apply a known calibrated signal level from the signal generator through the system check path at a mid-band fundamental frequency (f_0) in accordance with the general section of this standard.
- (2) Scan the measurement receiver in the same manner as a normal data scan. Verify the measurement receiver detects a level within ± 3 dB of the expected signal.
- (3) If readings are obtained which deviate by more than ± 3 dB, locate the source of the error and correct the deficiency prior to proceeding with the test.
- (4) Repeat 4.1b(1) through 4.1b(3) at the end points of the frequency range of test.

c. EUT Testing.

- (1) Turn on the EUT and allow sufficient time for stabilization.
- (2) Tune the EUT to the desired test frequency and use the measurement path to complete the rest of this procedure.
- (3) Tune the test equipment to the measurement frequency (f_0) of the EUT and adjust for maximum indication.
- (4) Apply the appropriate modulation for the EUT as indicated in the equipment specification.
- (5) Record the power level of the fundamental frequency (f_0) and the measurement receiver bandwidth.
- (6) Insert the fundamental frequency rejection network, when applicable.
- (7) Scan the frequency range of interest and record the level of all harmonics and spurious emissions. Add all correction factors for cable loss, attenuators and rejection networks. Maintain the same measurement receiver bandwidth used to measure the power level of the fundamental frequency (f_0) in 4.1c(5).

- (8) Verify spurious outputs are from the EUT and not spurious responses of the measurement system.
- (9) Repeat 4.1c(2) through 4.1c(8) for other f_0 of the EUT.
- (10) Determine measurement path losses at each spurious frequency as follows:
 - (a) Replace the EUT with a signal generator.
 - (b) Retain all couplers and rejection networks in the measurement path.
 - (c) Determine the losses through the measurement path. The value of attenuators may be reduced to facilitate the end-to-end check with a low level signal generator.

4.2 Transmitters (Stand-by Mode) and Receivers. The test procedure shall be as follows:

- a. Turn on the measurement equipment and allow a sufficient time for stabilization.
- b. Calibration.
 - (1) Apply a calibrated signal level, which 6 dB below the MIL-STD-461 limit, from the signal generator through the system check path at a midpoint test frequency in accordance with the general section of this standard.
 - (2) Scan the measurement receiver in the same manner as a normal data scan. Verify the measurement receiver detects a level within ± 3 dB of the injected signal.
 - (3) If readings are obtained which deviate by more than ± 3 dB, locate the source of the error and correct the deficiency prior to proceeding with the test.
 - (4) Repeat 4.2b(1) through 4.2b(3) at the end points of the frequency range of test.
- c. EUT Testing.
 - (1) Turn on the EUT and allow sufficient time for stabilization.

- (2) Tune the EUT to the desired test frequency and use the measurement path to complete the rest of this procedure.
- (3) Scan the measurement receiver over the applicable frequency range, using the bandwidths and minimum measurement times of the general section of this standard.
- (4) Repeat 4.2c(2) and 4.2c(3) for other frequencies as required by the general section of this standard.

5. Data Presentation.

5.1 Transmitters (Transmit Mode). The data presentation shall be as follows:

- a. Provide graphical or tabular data showing f_0 and frequencies of all harmonics and spurious emissions measured, power level of the fundamental and all harmonics and spurious emissions, dB down level, and all correction factors including cable loss, attenuator pads, and insertion loss of rejection networks.
- b. The relative dB down level is determined by subtracting the level in 4.1c(7) from that obtained in 4.1c(5).

5.2 Transmitters (Stand-by Mode) and Receivers. The data presentation shall be as follows:

- a. Continuously and automatically plot amplitude versus frequency profiles for each tuned frequency. Manually gathered data is not acceptable except for plot verification.
- b. Display the applicable limit on each plot.
- c. Provide a minimum frequency resolution of 1% or twice the measurement receiver bandwidth, whichever is less stringent, and a minimum amplitude resolution of 1 dB for each plot.
- d. Provide plots for both the measurement and system check portions of the procedure.

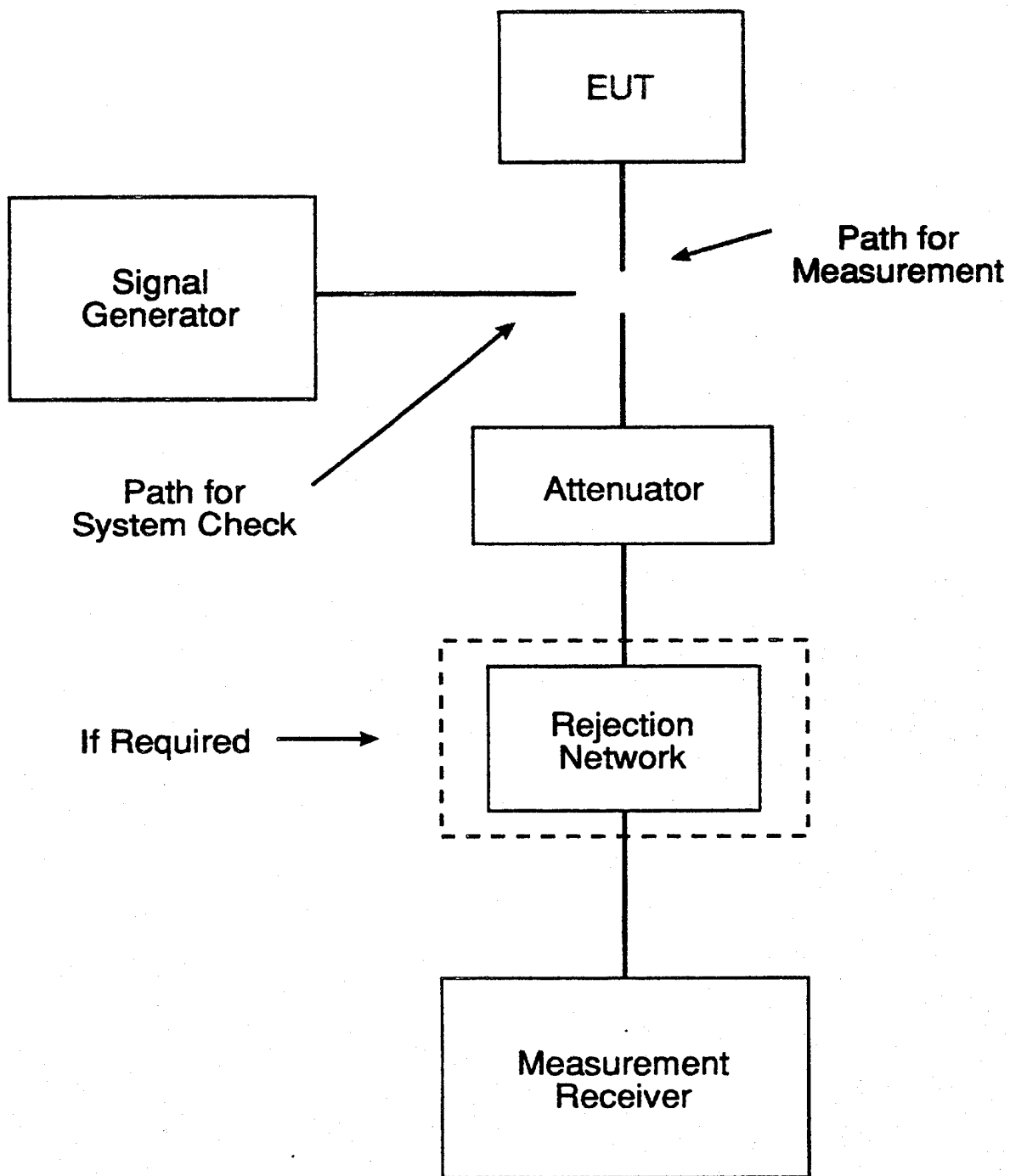

FIGURE CE106-1. Setup for low power transmitter.

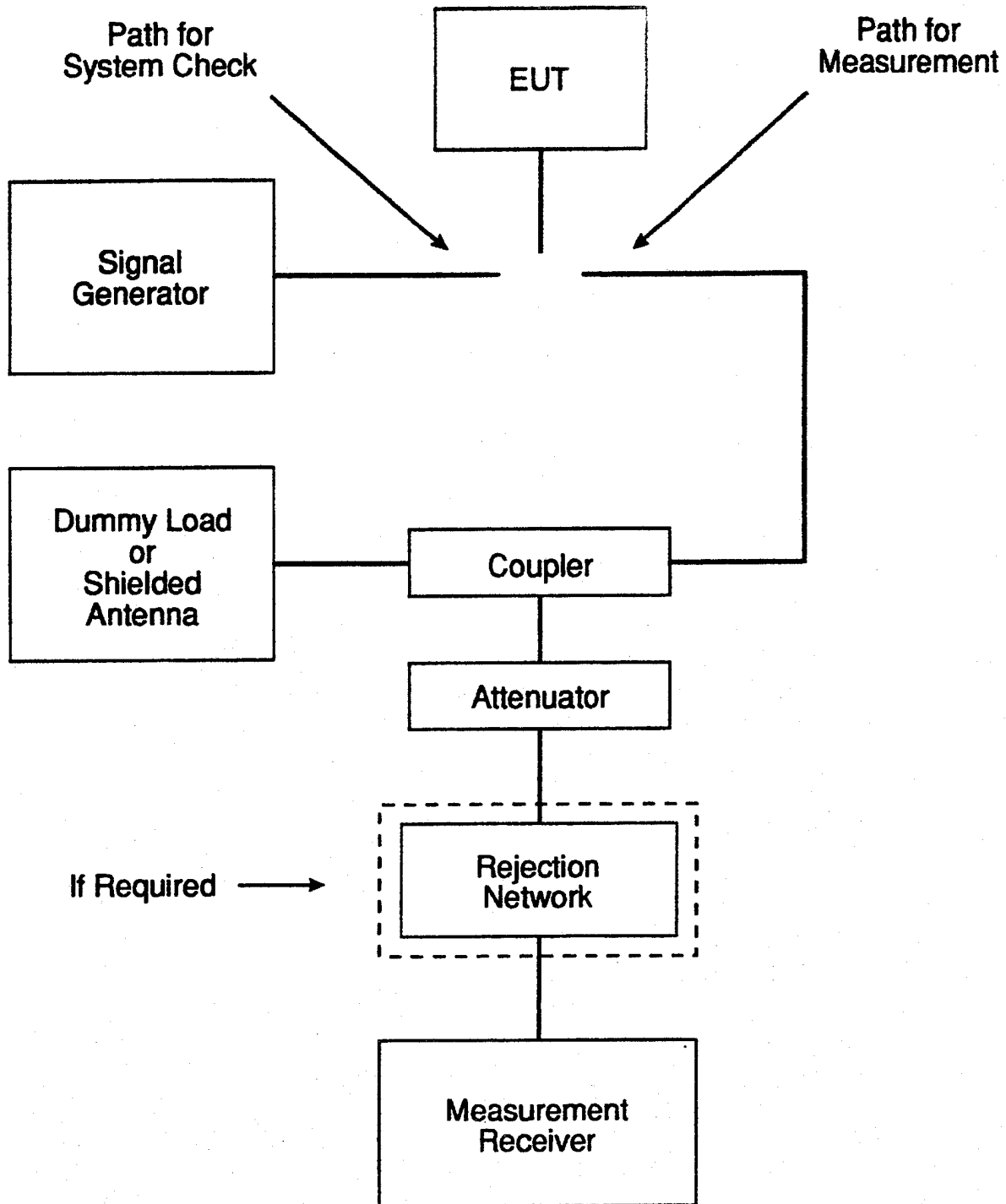

FIGURE CE106-2. Setup for high power transmitter.

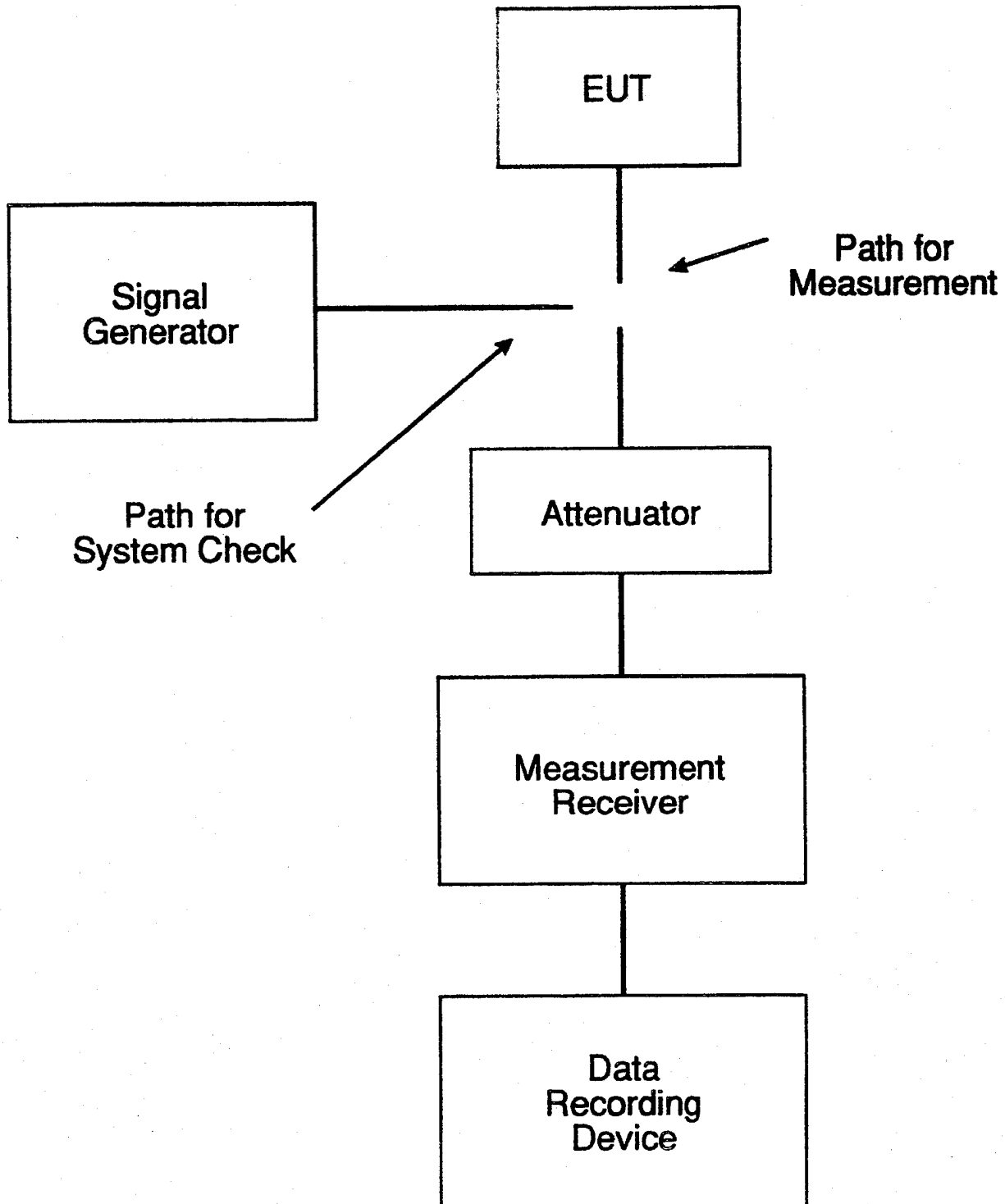

FIGURE CE106-3. Setup for transmitters (stand-by mode) and receivers.

METHOD CS101

CONDUCTED SUSCEPTIBILITY, POWER LEADS, 30 Hz TO 50 kHz

1. Purpose. This test method is used to verify the ability of the EUT to withstand signals coupled onto input power leads.
2. Test Equipment. The test equipment shall be as follows:
 - a. Signal generator
 - b. Power amplifier
 - c. Oscilloscope
 - d. Coupling transformer
 - e. Capacitor, 10 μ F
 - f. Isolation transformer
 - g. Resistor, 0.5 ohm
 - h. LISNs
3. Test Setup. The test setup shall be as follows:
 - a. Maintain a basic test setup for the EUT as shown and described in Figures 2 through 5 and paragraph 4.8 of the general section of this standard.
 - b. Calibration. Configure the test equipment in accordance with Figure CS101-1. Set up the oscilloscope to monitor the voltage across the 0.5 ohm resistor.
 - c. EUT testing.
 - (1) For DC or single phase AC power, configure the test equipment as shown in Figure CS101-2.
 - (2) For three phase delta power, configure the test setup as shown in Figure CS101-3.
 - (3) For three phase wye power (four power leads), configure the test setup as shown in Figure CS101-4.
4. Test Procedures. The test procedures shall be as follows:

- a. Turn on the measurement equipment and allow sufficient time for stabilization.
- b. Calibration.
 - (1) Set the signal generator to the lowest test frequency.
 - (2) Increase the applied signal until the oscilloscope indicates the voltage level corresponding to the maximum required power level specified in MIL-STD-461. Verify the output waveform is sinusoidal.
 - (3) Record the setting of the signal source.
 - (4) Scan the required frequency range for testing and record the signal source setting needed to maintain the required power level.
- c. EUT Testing.
 - (1) Turn on the EUT and allow sufficient time for stabilization. CAUTION: Exercise care when performing this test since the "safety ground" of the oscilloscope is disconnected and a shock hazard may be present.
 - (2) Set the signal generator to the lowest test frequency. Increase the signal level until the required voltage or power level is reached on the power lead. (Note: Voltage is limited to the level calibrated in 4b(2).)
 - (3) While maintaining at least the required signal level, scan through the required frequency range at a rate no greater than specified in Table III of the general section of this standard.
 - (4) Susceptibility evaluation.
 - (a) Monitor the EUT for degradation of performance.
 - (b) If susceptibility is noted, determine the level at which the undesirable response is no longer present and verify that it is above the MIL-STD-461 requirement.

- (5) Repeat 4c(2) through 4c(4) for each power lead, as required. For three phase delta power, the measurements shall be made according to the following table:

Coupling Transformer in Line	Voltage Measurement From
A	A to B
B	B to C
C	C to A

For three phase wye power (four leads) the measurements shall be made according to the following table:

Coupling Transformer in Line	Voltage Measurement From
A	A to neutral
B	B to neutral
C	C to neutral

5. Data Presentation. Data presentation shall be as follows:
- a. Provide graphical or tabular data showing the frequencies and amplitudes at which the test was conducted for each lead.
 - b. Provide data on any susceptibility thresholds and the associated frequencies which were determined for each power lead.
 - c. Provide indications of compliance with the MIL-STD-461 requirements for the susceptibility evaluation specified in 4c for each lead.

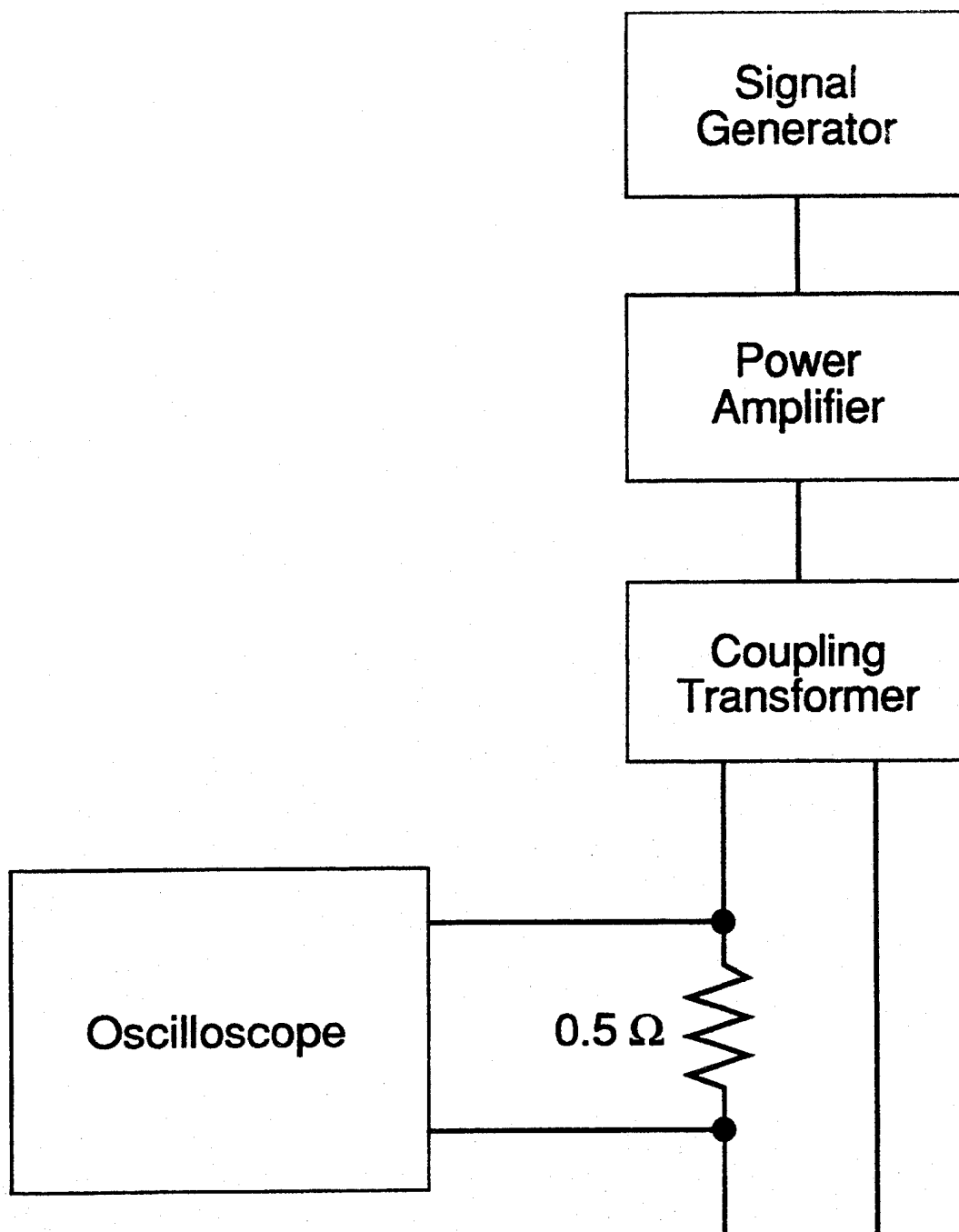

FIGURE CS101-1. Calibration.

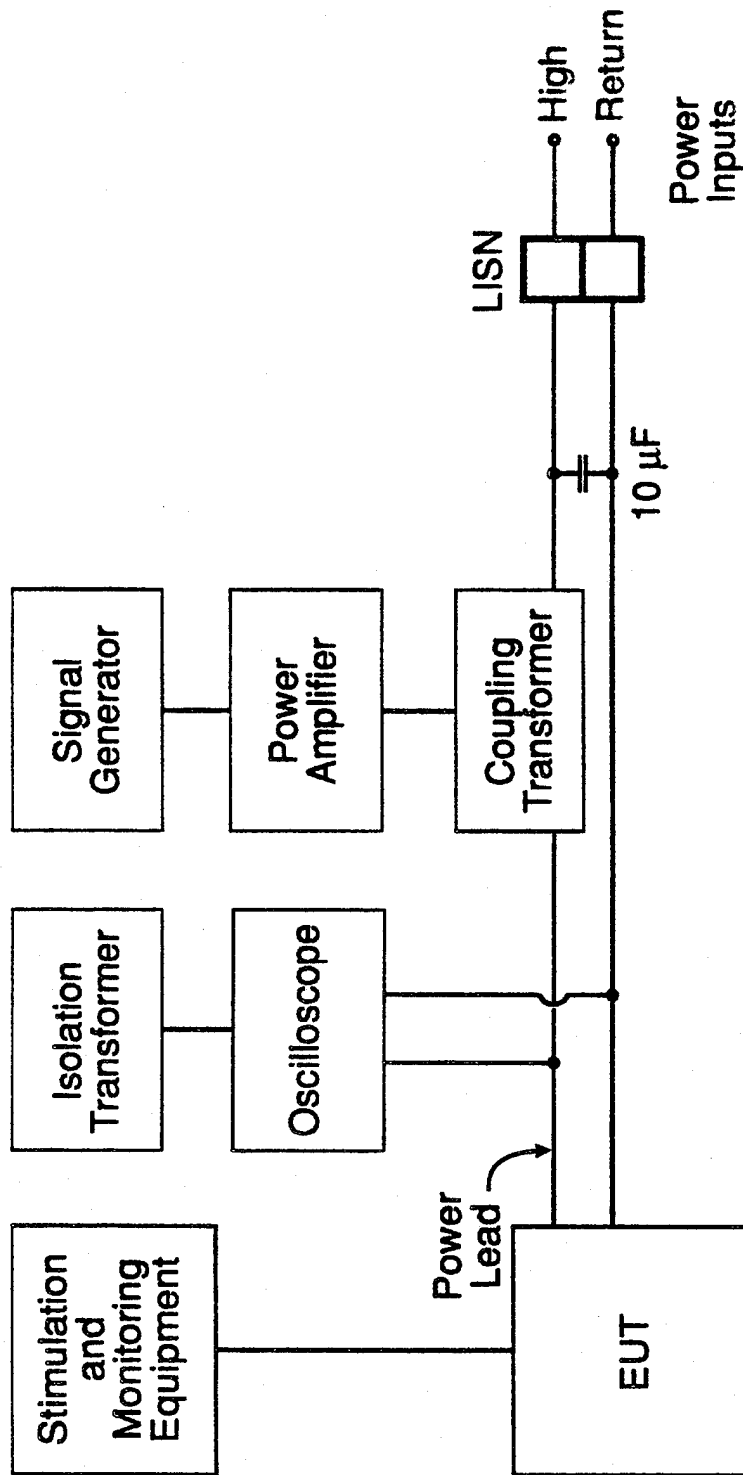

FIGURE CS101-2. Signal injection, DC or single phase AC.

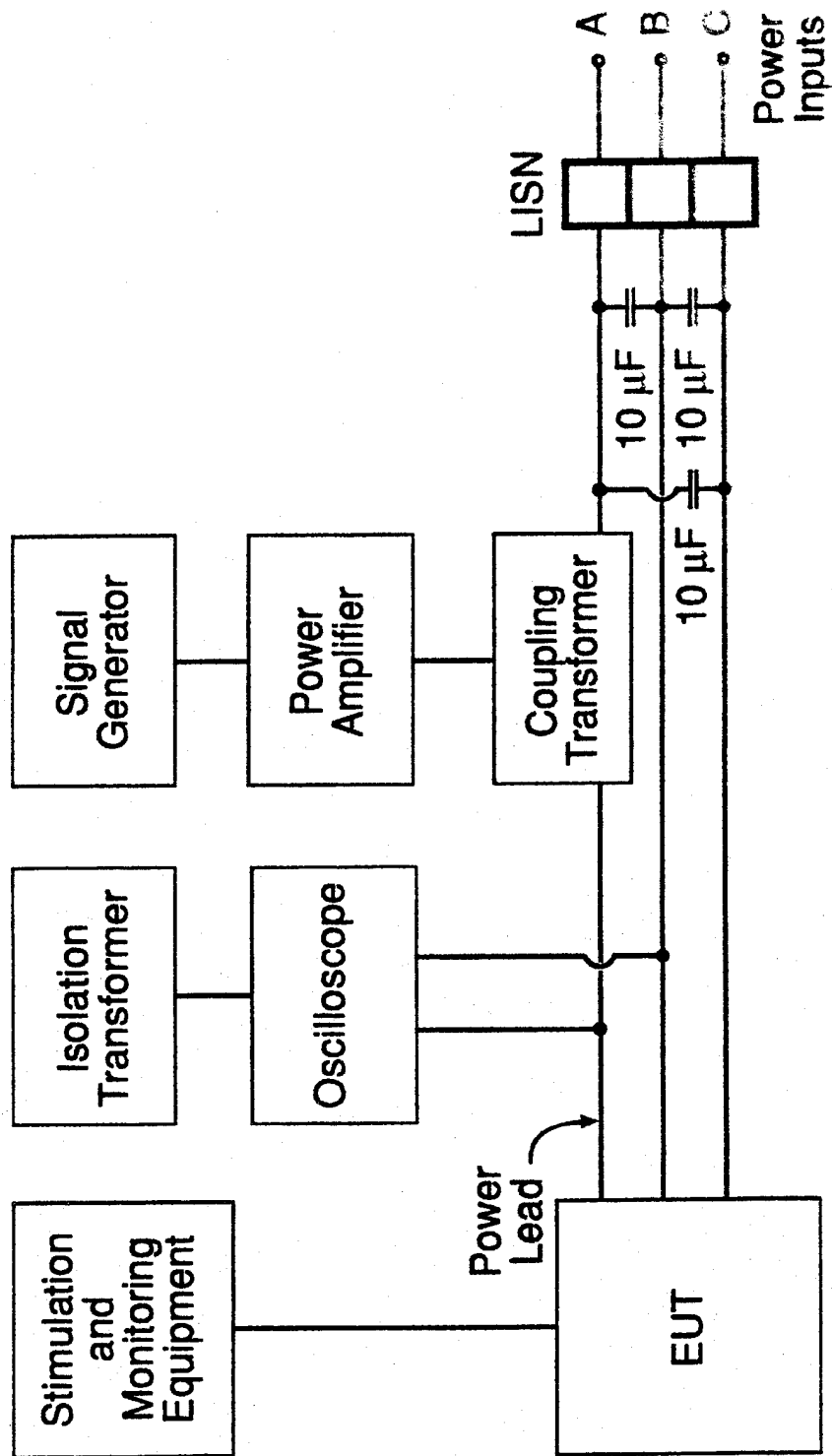

FIGURE CS101-3. Signal injection, 3-phase delta.

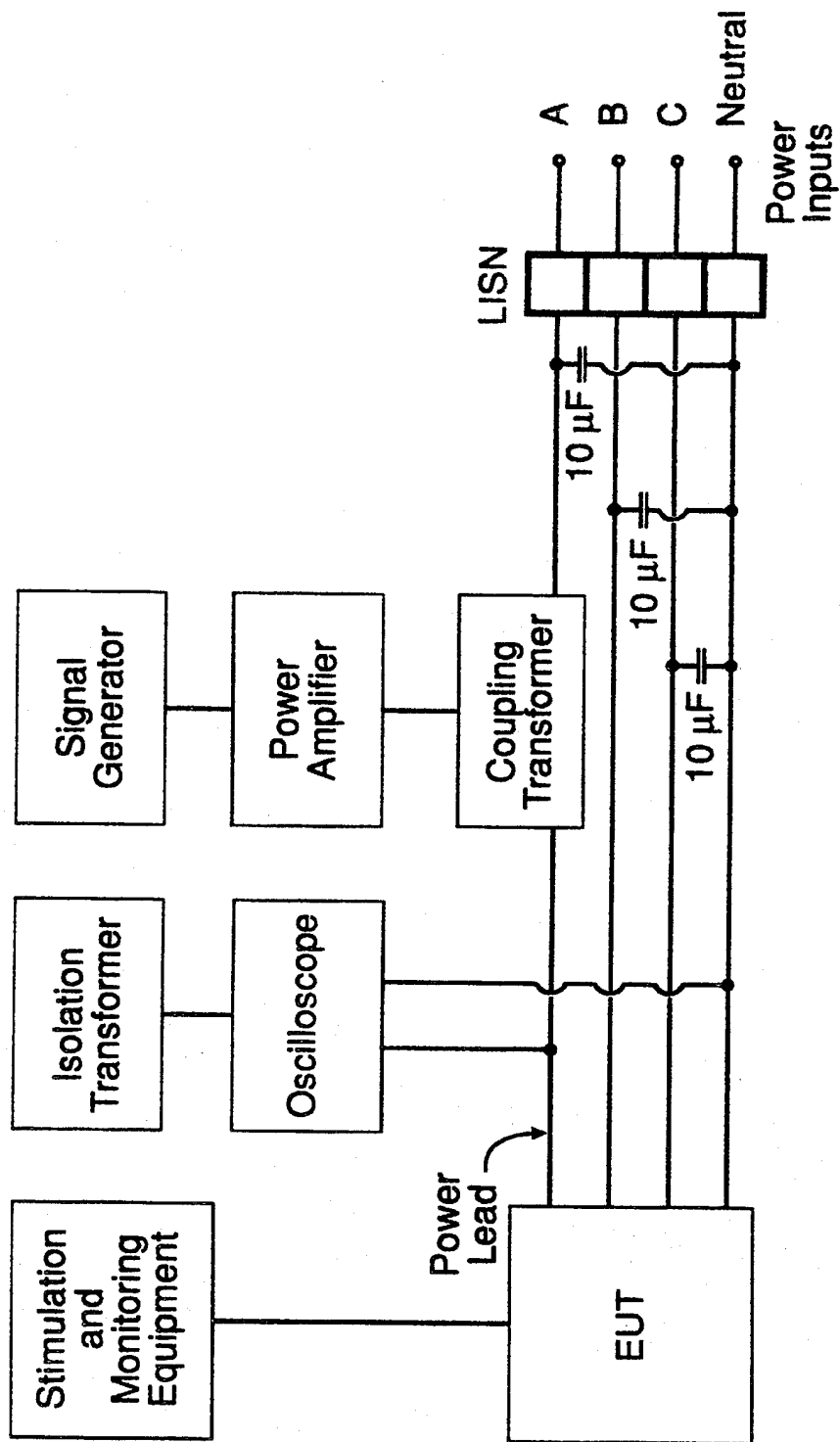

FIGURE CS101-4. Signal injection, 3-phase wye.

MIL-STD-462D

METHOD CS103

CONDUCTED SUSCEPTIBILITY, ANTENNA PORT, INTERMODULATION,
15 kHz TO 10 GHz

1. Purpose. This test method is to determine the presence of intermodulation products that may be caused by undesired signals at the EUT antenna input terminals.

2. Test Requirements. The required test equipment, test setup, test procedures, and data presentation shall be determined in accordance with the guidance provided in the appendix of this standard. The test requirements shall be described in the EMITP required by MIL-STD-461.

MIL-STD-462D

METHOD CS104

CONDUCTED SUSCEPTIBILITY, ANTENNA PORT, REJECTION OF
UNDESIREO SIGNALS, 30 Hz TO 20 GHz

1. Purpose. This test method is to determine the presence of spurious responses that may be caused by undesired signals at the EUT antenna input terminals.

2. Test Requirements. The required test equipment, test setup, test procedures, and data presentation shall be determined in accordance with the guidance provided in the appendix of this standard. The test requirements shall be described in the EMITP required by MIL-STD-461.

MIL-STD-462D

METHOD CS105

CONDUCTED SUSCEPTIBILITY, ANTENNA PORT, CROSS-MODULATION,
30 Hz TO 20 GHz

1. Purpose. This test method is to determine the presence of cross-modulation products that may be caused by undesired signals at the EUT antenna terminals.
2. Test Requirements. The required test equipment, test setup, test procedures, and data presentation shall be determined in accordance with the guidance provided in the appendix of this standard. The test requirements shall be described in the EMITP required by MIL-STD-461.

METHOD CS109

CONDUCTED SUSCEPTIBILITY, STRUCTURE CURRENT, 60 Hz TO 100 kHz

1. Purpose. This test method is used to verify the ability of the EUT to withstand structure currents.
2. Test Equipment. The test equipment shall be as follows:
 - a. Signal generator
 - b. Oscilloscope or voltmeter
 - c. Resistor, 0.5 ohm
 - d. Isolation transformers
3. Test Setup. The test setup shall be as follows:
 - a. It is not necessary to maintain the basic test setup for the EUT as shown and described in figures 2 through 5 and paragraph 4.8 of the general section of this standard.
 - b. Calibration. No special calibration is required.
 - c. EUT testing. CAUTION: Exercise care when setting up and performing this test since the input power safety ground leads are disconnected.
 - (1) As shown in Figure CS109-1, configure the EUT and the test equipment (including the test signal source, the test current measurement equipment, and the equipment required for operating the EUT or measuring performance degradation) to establish a single-point ground for the test setup.
 - (a) Using isolation transformers, isolate all AC power sources. For DC power, isolation transformers are not applicable.
 - (b) Disconnect the safety ground leads of all input power cables.
 - (c) Place the EUT and the test equipment on non-conductive surfaces.

(2) The test points for injected currents shall be at diagonal extremes across all surfaces of the EUT.

(3) Connect the signal generator and resistor to a selected set of test points.

4. Test Procedures. The test procedures shall be as follows:

a. Turn on the EUT and measurement equipment and allow sufficient time for stabilization.

b. Set the signal generator to the lowest required frequency. Adjust the signal generator to the required level. Monitor the current by measuring the voltage developed across the resistor.

c. Scan the signal generator over the required frequency range in accordance with the general section of this standard while maintaining the current level as specified in the applicable limit. Monitor the EUT for susceptibility.

d. If susceptibility is noted, determine the level at which the undesirable response is no longer present and verify that it is above the MIL-STD-461 requirement.

e. Repeat 4b through 4d for each diagonal set of test points on each surface of the EUT to be tested.

5. Data Presentation. Data presentation shall be as follows:

a. Provide a table showing the mode of operation, susceptible frequency, current threshold level, current limit level, and susceptible test points.

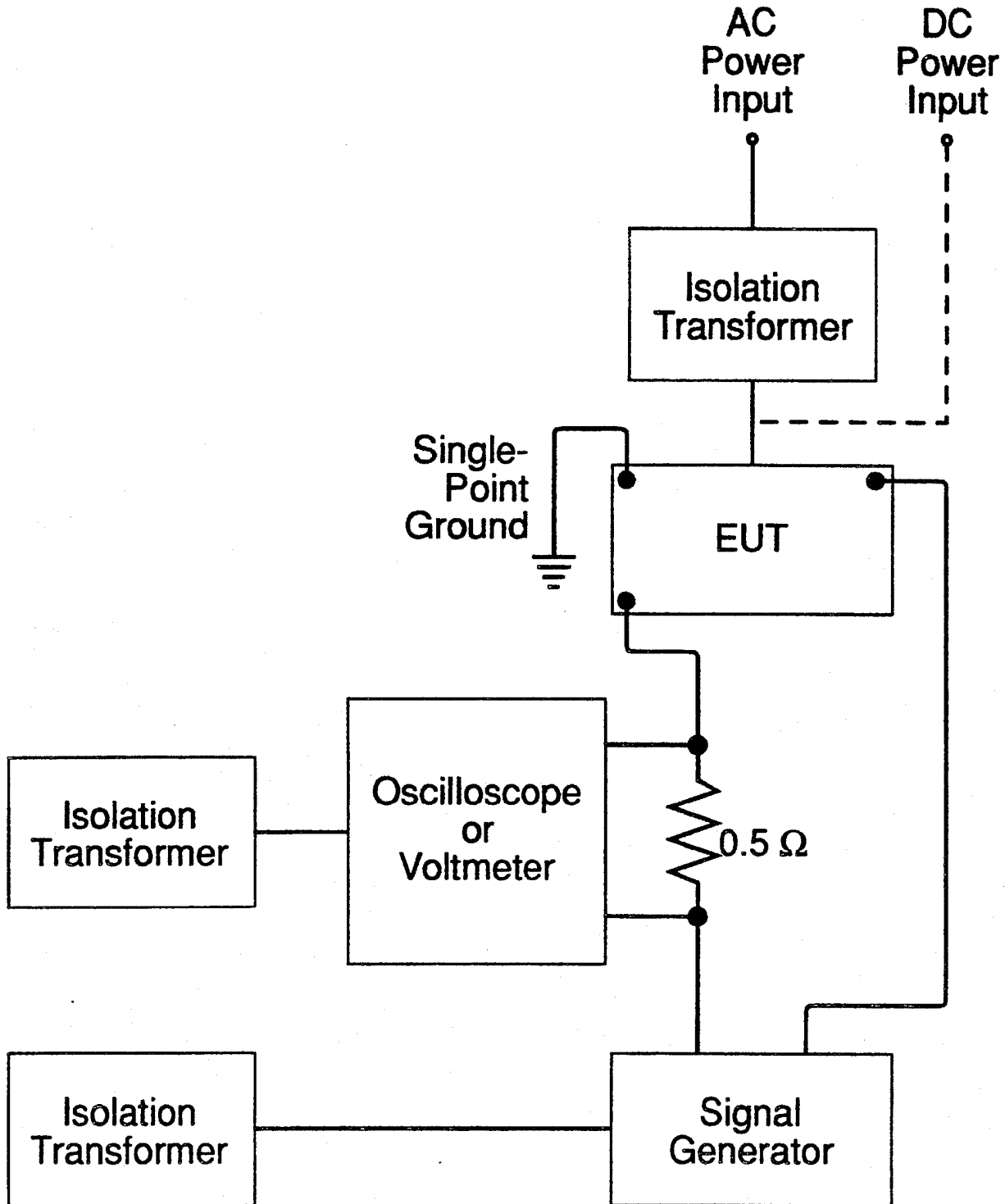

FIGURE CS109-1. Test Configuration.

METHOD CS114

CONDUCTED SUSCEPTIBILITY, BULK CABLE INJECTION, 10 kHz TO 400 MHz

1. Purpose. This test method is used to verify the ability of the EUT to withstand RF signals coupled onto EUT associated cabling.

2. Test Equipment. The test equipment shall be as follows:

- a. Measurement receivers
- b. Current injection probes
- c. Current probes
- d. Calibration fixture: coaxial transmission line with 50 ohm characteristic impedance, coaxial connections on both ends, and space for an injection probe around the center conductor.
- e. Directional couplers
- f. Signal generators
- g. Plotter
- h. Attenuators, 50 ohm
- i. Coaxial loads, 50 ohm
- j. Power amplifiers
- k. LISNs

3. Test Setup. The test setup shall be as follows:

- a. Maintain a basic test setup for the EUT as shown and described in Figures 2 through 5 and paragraph 4.8 of the general section of this standard.
- b. Calibration. Configure the test equipment in accordance with Figure CS114-1 for calibrating injection probes.
 - (1) Place the injection probe around the center conductor of the calibration fixture.

- (2) Terminate one end of the calibration fixture with a 50 ohm load and terminate the other end with an attenuator connected to measurement receiver A.
- c. EUT Testing. Configure the test equipment as shown in Figure CS114-2 for testing of the EUT.
 - (1) Place the injection and monitor probes around a cable bundle interfacing with an EUT connector.
 - (2) Locate the monitor probe 5 cm from the connector. If the overall length of the connector and backshell exceeds 5 cm, position the monitor probe as close to the connector's backshell as possible.
 - (3) Position the injection probe 5 cm from the monitor probe.
4. Test Procedures. The test procedures shall be as follows:
 - a. Turn on the measurement equipment and allow sufficient time for stabilization.
 - b. Calibration. Perform the following procedures using the calibration setup.
 - (1) Set the signal generator to 10 kHz, unmodulated.
 - (2) Increase the applied signal until measurement receiver A indicates the current level specified in MIL-STD-461 is flowing in the center conductor of the calibration fixture.
 - (3) Record the "forward power" to the injection probe indicated on measurement receiver B.
 - (4) Scan the frequency band from 10 kHz to 400 MHz and record the forward power needed to maintain the required current amplitude.
 - c. EUT Testing. Perform the following procedures on each cable bundle interfacing with each electrical connector on the EUT including complete power cables (high sides and returns). Also perform the procedures on power cables with the power returns excluded from the cable bundle.

MIL-STD-462D

- (1) Turn on the EUT and allow sufficient time for stabilization.
- (2) Loop circuit impedance characterization.
 - (a) Set the signal generator to 10 kHz, unmodulated.
 - (b) Apply a power level of approximately 1 mW to the injection probe and record both the power level indicated by measurement receiver B and the induced current level indicated by measurement receiver A.
 - (c) Scan the frequency range from 10 kHz to 400 MHz and record the applied power level and induced current level.
 - (d) Normalize the measurement results to amperes for 1 watt of applied power.
- (3) Susceptibility evaluation.
 - (a) Set the signal generator to 10 kHz with 1 kHz pulse wave modulation, 50% duty cycle.
 - (b) Apply the forward power level determined under 4b(4) to the injection probe while monitoring the induced current.
 - (c) Scan the required frequency range in accordance with the general section of this standard while maintaining the forward power level at the calibration level determined under 4b(4), or the maximum current level in MIL-STD-461, whichever is less stringent.
 - (d) Monitor the EUT for degradation of performance during testing.
 - (e) Whenever susceptibility is noted, determine the level at which the undesirable response is no longer present and verify that it is above the MIL-STD-461 requirement.
 - (f) For EUTs with redundant cabling for safety critical reasons such as multiple data buses, use simultaneous multi-cable injection techniques.

5. Data Presentation. Data presentation shall be as follows:
- a. Provide amplitude versus frequency plots for the forward power levels required to obtain the calibration level as determined in 4b.
 - b. Provide amplitude versus frequency plots for the amperes for 1 watt of applied power for each EUT connector interface as determined in 4c(2).
 - c. Provide tables showing scanned frequency ranges and statements of compliance with the MIL-STD-461 requirement for the susceptibility evaluation of 4c(3) for each interface connector. Provide any susceptibility thresholds which were determined, along with their associated frequencies.

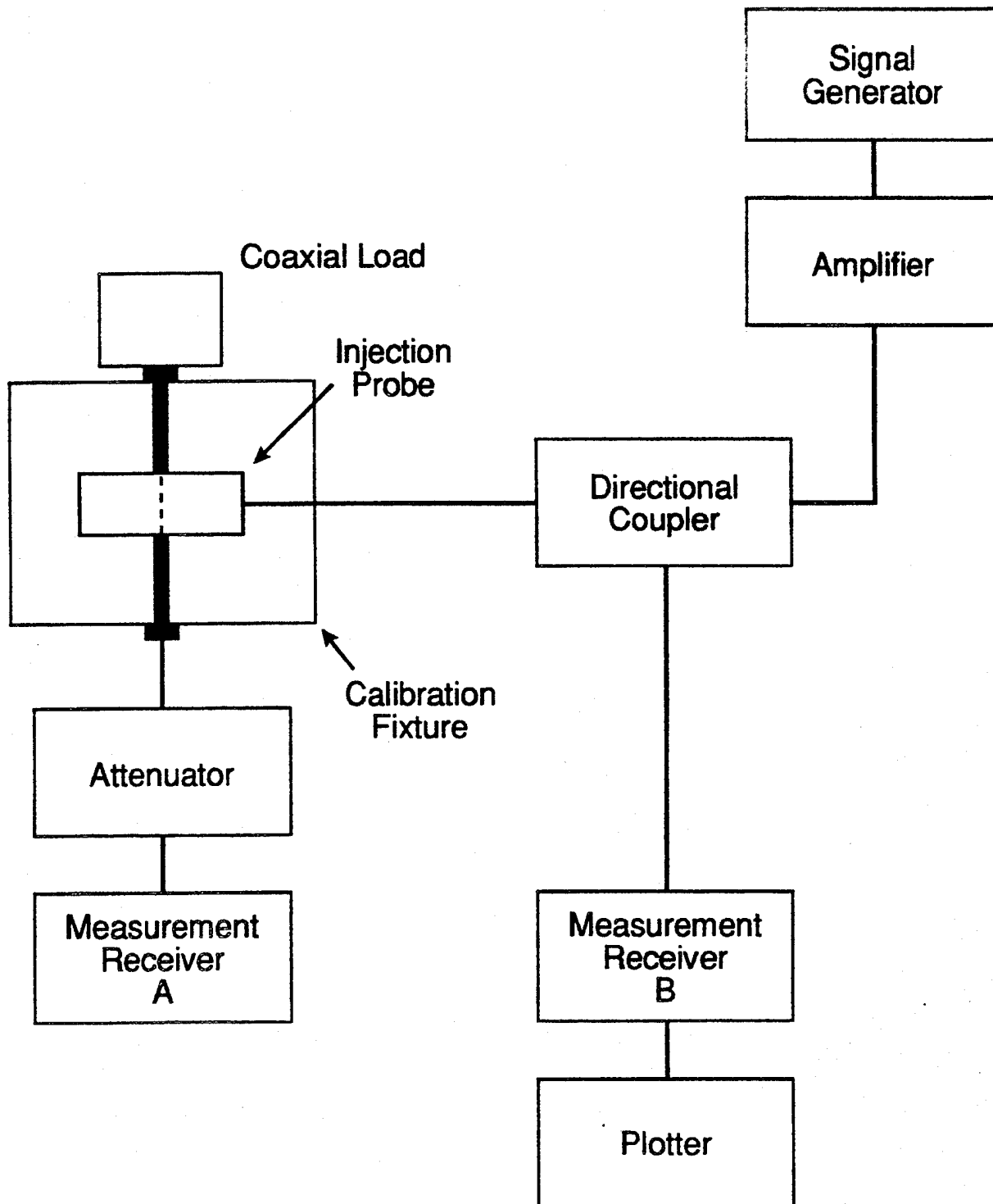

FIGURE CS114-1. Calibration setup.

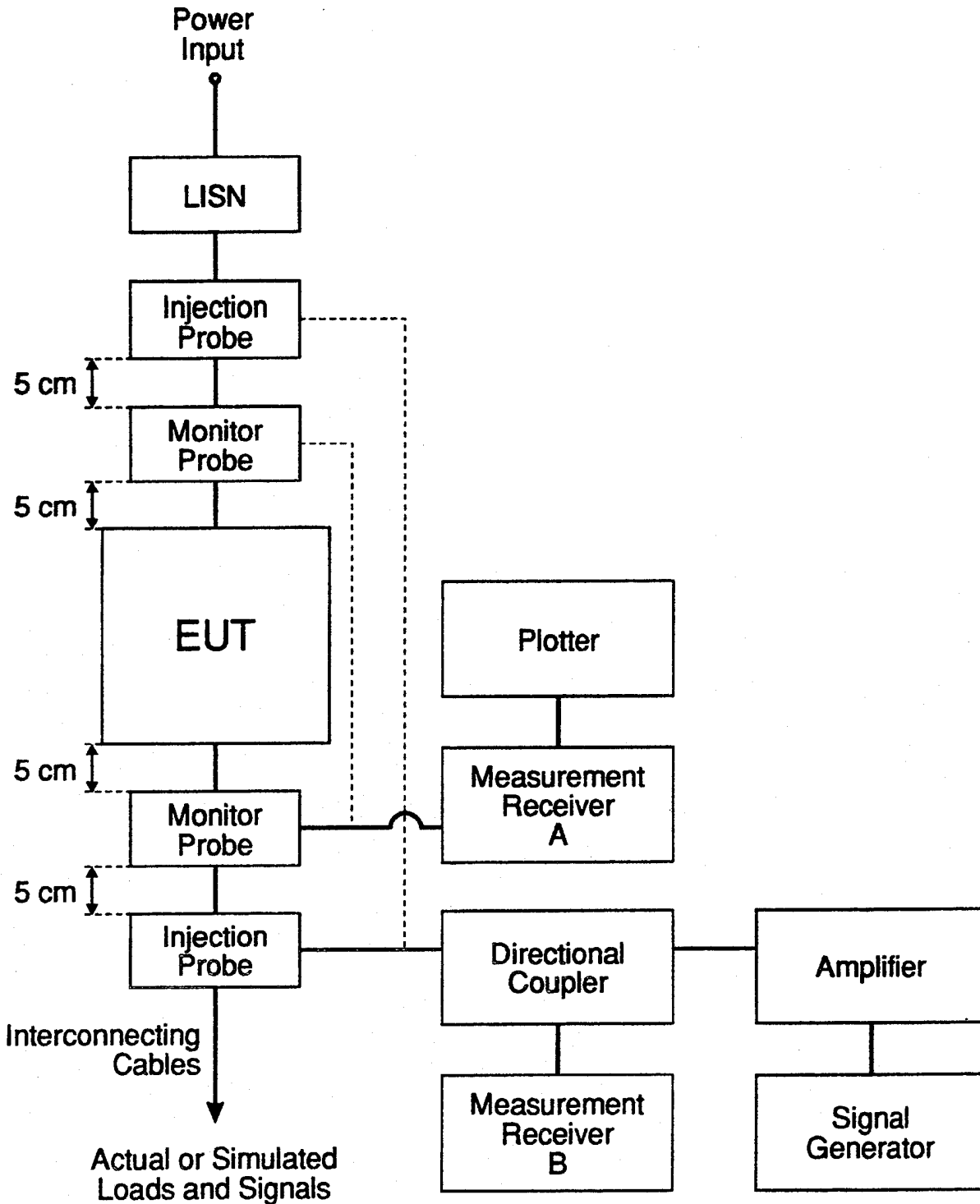

FIGURE CS114-2. Bulk cable injection and loop circuit impedance evaluations.

METHOD CS115

CONDUCTED SUSCEPTIBILITY, BULK CABLE INJECTION,
IMPULSE EXCITATION

1. Purpose. This test method is used to verify the ability of the EUT to withstand impulse signals coupled onto EUT associated cabling.
2. Test Equipment. The test equipment shall be as follows:
 - a. Pulse generator, 50 ohm, charged line
 - b. Current injection probe
 - c. Drive cable, 50 ohm, 2 meters, 0.5 dB or less insertion loss at 500 MHz
 - d. Current probe
 - e. Calibration fixture: coaxial transmission line with 50 ohm characteristic impedance, coaxial connections on both ends, and space for an injection probe around the center conductor.
 - f. Oscilloscope, 50 ohm input impedance
 - g. Attenuators, 50 ohm
 - h. Coaxial loads, 50 ohm
 - i. LISNs
3. Test Setup. The test setup shall be as follows:
 - a. Maintain a basic test setup for the EUT as shown and described in Figures 2 through 5 and paragraph 4.8 of the general section of this standard.
 - b. Calibration. Configure the test equipment in accordance with Figure CS115-1 for calibrating the injection probe.
 - (1) Place the injection probe around the center conductor of the calibration fixture.
 - (2) Terminate one end of the calibration fixture with a coaxial load and terminate the other end with an

attenuator connected to an oscilloscope with 50 ohm input impedance.

c. EUT Testing. Configure the test equipment as shown in Figure CS115-2 for testing of the EUT.

- (1) Place the injection and monitor probes around a cable bundle interfacing with an EUT connector.
- (2) Locate the monitor probe 5 cm from the connector. If the overall length of the connector and backshell exceeds 5 cm, position the monitor probe as close to the connector's backshell as possible.
- (3) Position the injection probe 5 cm from the monitor probe.

4. Test Procedures. The test procedures shall be as follows:

- a. Turn on the measurement equipment and allow sufficient time for stabilization.
- b. Calibration. Perform the following procedures using the calibration setup.
 - (1) Adjust the pulse generator source for the risetime, pulse width, and pulse repetition rate requirements specified in MIL-STD-461.
 - (2) Increase the signal applied to the calibration fixture until the oscilloscope indicates that the current level specified in MIL-STD-461 is flowing in the center conductor of the calibration fixture.
 - (3) Verify that the rise time, fall time, and pulse width portions of the waveform have the correct durations and that the correct repetition rate is present. The precise pulse shape will not be reproduced due to the inductive coupling mechanism.
 - (4) Record the pulse generator amplitude setting.
- c. EUT Testing.
 - (1) Turn on the EUT and allow sufficient time for stabilization.
 - (2) Susceptibility evaluation.

MIL-STD-462D

- (a) Adjust the pulse generator, as a minimum, for the amplitude setting determined in 4b(4).
- (b) Apply the test signal at the pulse repetition rate and for the duration specified in MIL-STD-461.
- (c) Monitor the EUT for degradation of performance during testing.
- (d) Whenever susceptibility is noted, determine the level at which the undesirable response is no longer present and verify that it is above the MIL-STD-461 requirement.
- (e) Record the peak current induced in the cable as indicated on the oscilloscope.
- (f) Repeat 4c(2) (a) through 4c(2) (e) on each cable bundle interfacing with each electrical connector on the EUT. For power cables, perform 4c(2) (a) through 4c(2) (e) on complete power cables (high sides and returns) and on the power cables with the power returns excluded from the cable bundle.

5. Data Presentation. Data presentation shall be as follows:

- a. Provide tables showing statements of compliance with the MIL-STD-461 requirement for the susceptibility evaluation of 4c(2) and the induced current level for each interface connector.
- b. Provide any susceptibility thresholds which were determined.
- c. Provide oscilloscope photographs of injected waveforms with test data.

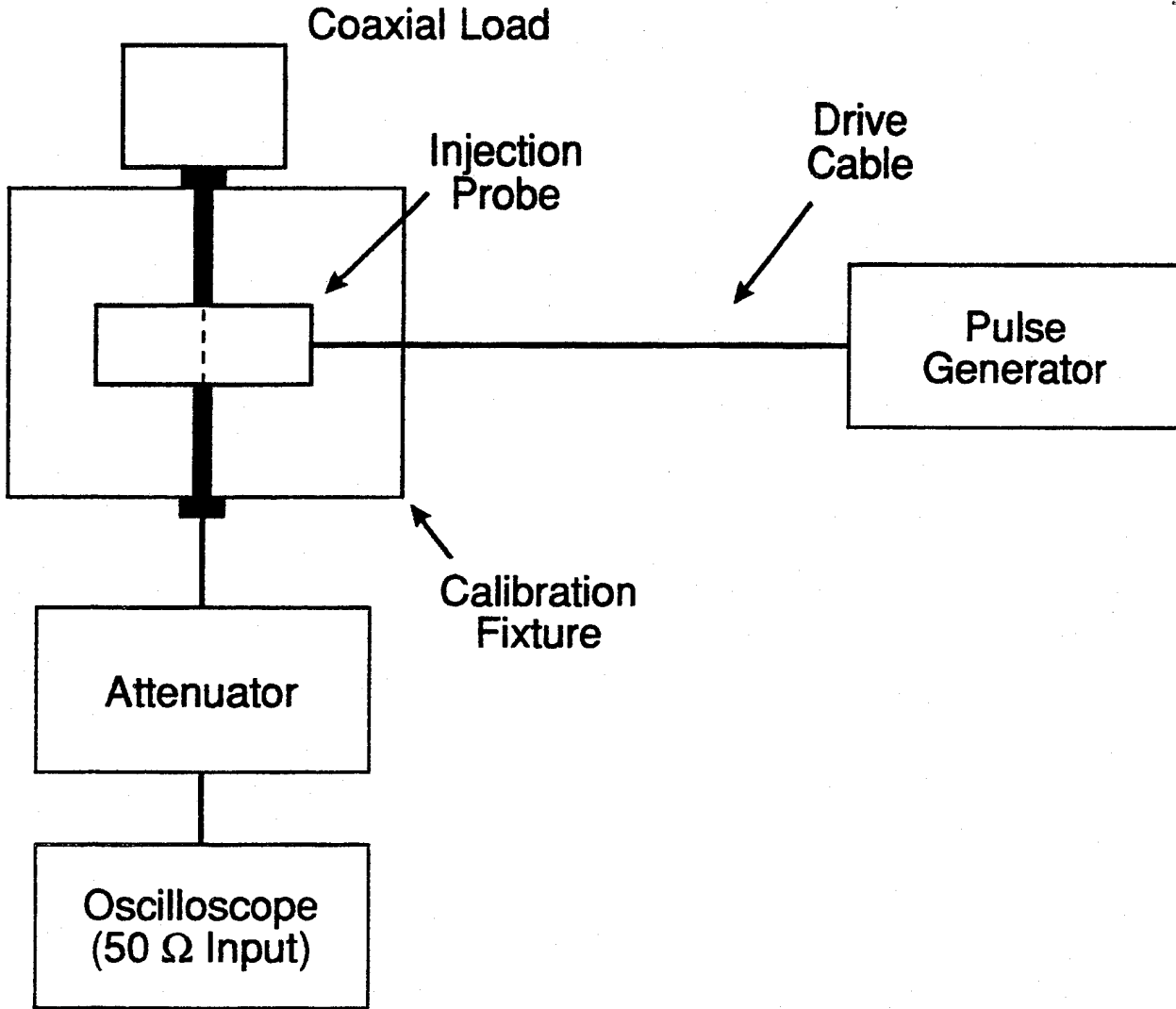

FIGURE CS115-1. Calibration setup.

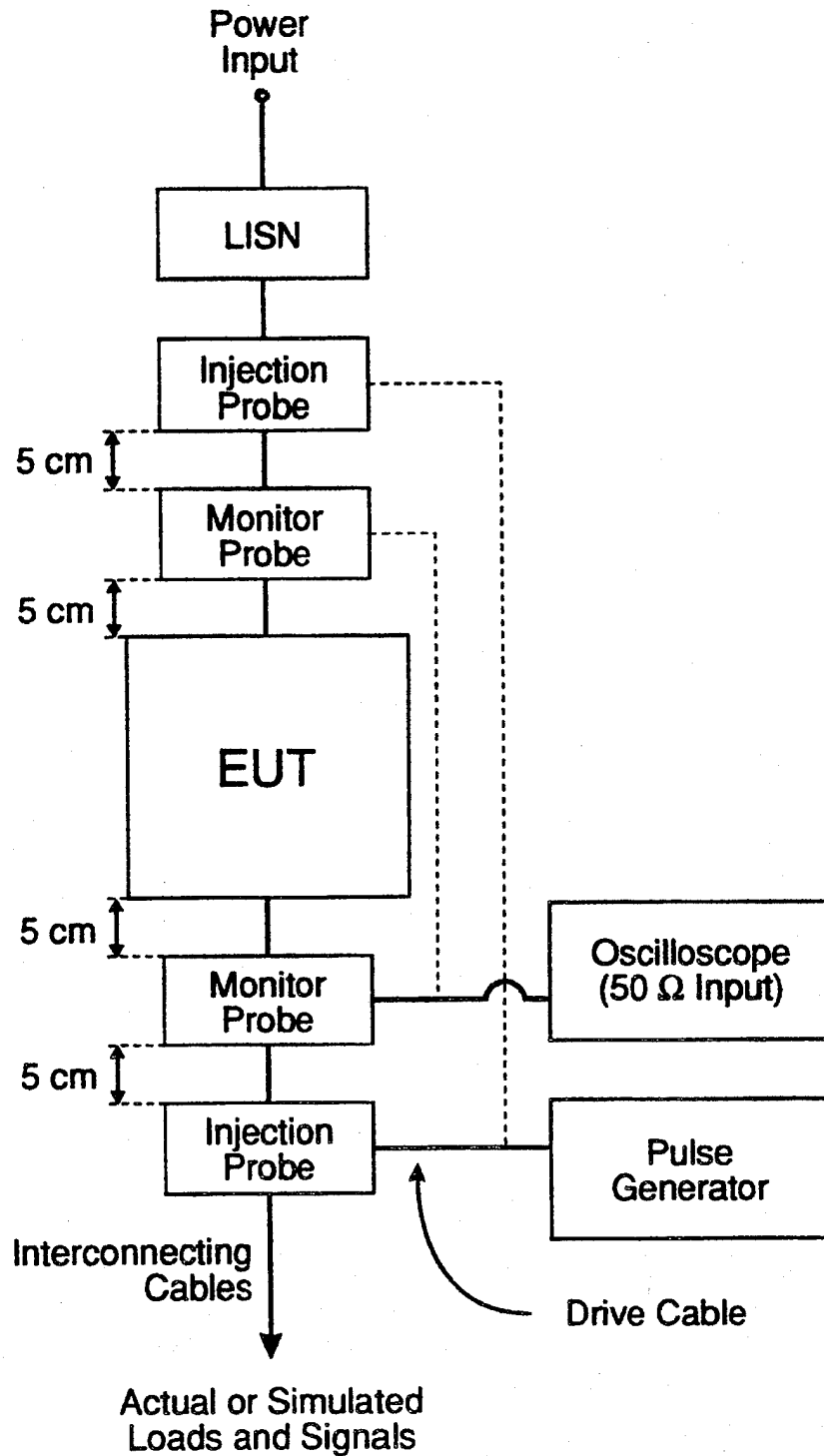

FIGURE CS115-2. Bulk cable injection.

METHOD CS116

CONDUCTED SUSCEPTIBILITY, DAMPED SINUSOIDAL TRANSIENTS,
CABLES AND POWER LEADS, 10 kHz TO 100 MHz

1. Purpose. This test method is used to verify the ability of the EUT to withstand damped sinusoidal transients coupled onto EUT associated cables and power leads.
2. Test Equipment. The test equipment shall be as follows:
 - a. Damped sinusoid transient generator, ≤ 100 ohm output impedance
 - b. Current injection probe
 - c. Oscilloscope, 50 ohm input impedance
 - d. Calibration fixture: Coaxial transmission line with 50 ohm characteristic impedance, coaxial connections on both ends, and space for an injection probe around the center conductor
 - e. Current probes
 - f. Waveform recording device
 - g. Attenuators
 - h. Measurement receivers
 - i. Power amplifiers
 - j. Coaxial loads
 - k. Signal generators
 - l. Directional couplers
 - m. LISNs
3. Test Setup. The test setup shall be as follows:
 - a. Maintain a basic test setup for the EUT as shown and described in Figures 2 through 5 and paragraph 4.8 of the general section of this standard.

- b. Calibration. Configure the test equipment in accordance with Figure CS116-1 for verification of the waveform.
- c. EUT Testing:
 - (1) Loop Circuit Impedance Characterization.
 - (a) Configure the test equipment in accordance with Figure CS116-2.
 - (b) Place the injection and monitor probes around a cable bundle interfacing with an EUT connector.
 - (c) Locate the monitor probe 5 cm from the connector. If the overall length of the connector and backshell exceeds 5 cm, position the monitor probe as close to the connector's backshell as possible.
 - (d) Position the injection probe 5 cm from the monitor probe.
 - (2) Susceptibility Evaluation.
 - (a) Configure the test equipment as shown in Figure CS116-3.
 - (b) Place the injection and monitor probes around a cable bundle interfacing an EUT connector.
 - (c) Locate the monitor probe 5 cm from the connector. If the overall length of the connector and backshell exceeds 5 cm, position the monitor probe as close to the connector's backshell as possible.
 - (d) Position the injection probe 5 cm from the monitor probe.
- 4. Test Procedures. The test procedures shall be as follows:
 - a. Turn on the measurement equipment and allow sufficient time for stabilization.
 - b. Calibration. Perform the following procedures using the calibration setup for waveform verification.

MIL-STD-462D

- (1) Set the frequency of the damped sine generator at 10 kHz.
 - (2) Adjust the amplitude of the signal from the damped sine generator to the level required in MIL-STD-461.
 - (3) Record the damped sine generator settings.
 - (4) Verify that the waveform complies with the requirements of MIL-STD-461.
 - (5) Repeat 4b(2) through 4b(4) for each frequency specified in MIL-STD-461 and those identified in 4c(2).
- c. EUT Testing. Perform the following procedures, using the EUT test setup on each cable bundle interfacing with each connector on the EUT including complete power cables. Also perform tests on each individual power lead.
- (1) Turn on the EUT and allow sufficient time for stabilization.
 - (2) Loop Circuit Impedance Characterization.
 - (a) Set the signal generator to 10 kHz, unmodulated.
 - (b) Apply a power level of approximately 1 mW to the injection probe and record both the power level indicated by measurement receiver B and the induced current level indicated by measurement receiver A.
 - (c) Scan the frequency range from 10 kHz to 100 MHz and record the applied power and induced current level.
 - (d) Adjust the measurement results to amperes for 1 watt of applied power.
 - (e) Identify the resonance frequencies where the maximum and minimum impedances occur.
 - (3) Susceptibility evaluation.
 - (a) Turn on the EUT and measurement equipment to allow sufficient time for stabilization.

- (b) Set the damped sine generator to a test frequency.
- (c) Apply the test signals to each cable or power lead of the EUT sequentially. Slowly increase the damped sinewave generator output level to provide the specified current, but not exceeding the precalibrated generator output level. Record the peak current obtained.
- (d) Monitor the EUT for degradation of performance.
- (e) If susceptibility is noted, determine the level at which the undesirable response is no longer present and verify that it is above the specified requirements.
- (f) Repeat 4c(3)(b) through 4c(3)(e) for each test frequency as specified in MIL-STD-461 and resonance frequencies as determined in 4c(2). Repeat testing in 4c(3) for the power-off condition.

5. Data Presentation. Data presentation shall be as follows:

- a. Provide a list of the frequencies and amplitudes at which the test was conducted for each cable and lead.
- b. Provide amplitude versus frequency plots for the amperes for 1 watt of applied power for each EUT connector interface as determined in 4c(2)(d).
- c. Provide data on any susceptibility thresholds and the associated frequencies which were determined for each connector and power lead.
- d. Provide indications of compliance with the MIL-STD-461 requirements for the susceptibility evaluation specified in 4c for each interface connector.
- e. Provide oscilloscope photographs of injected waveforms with test data.

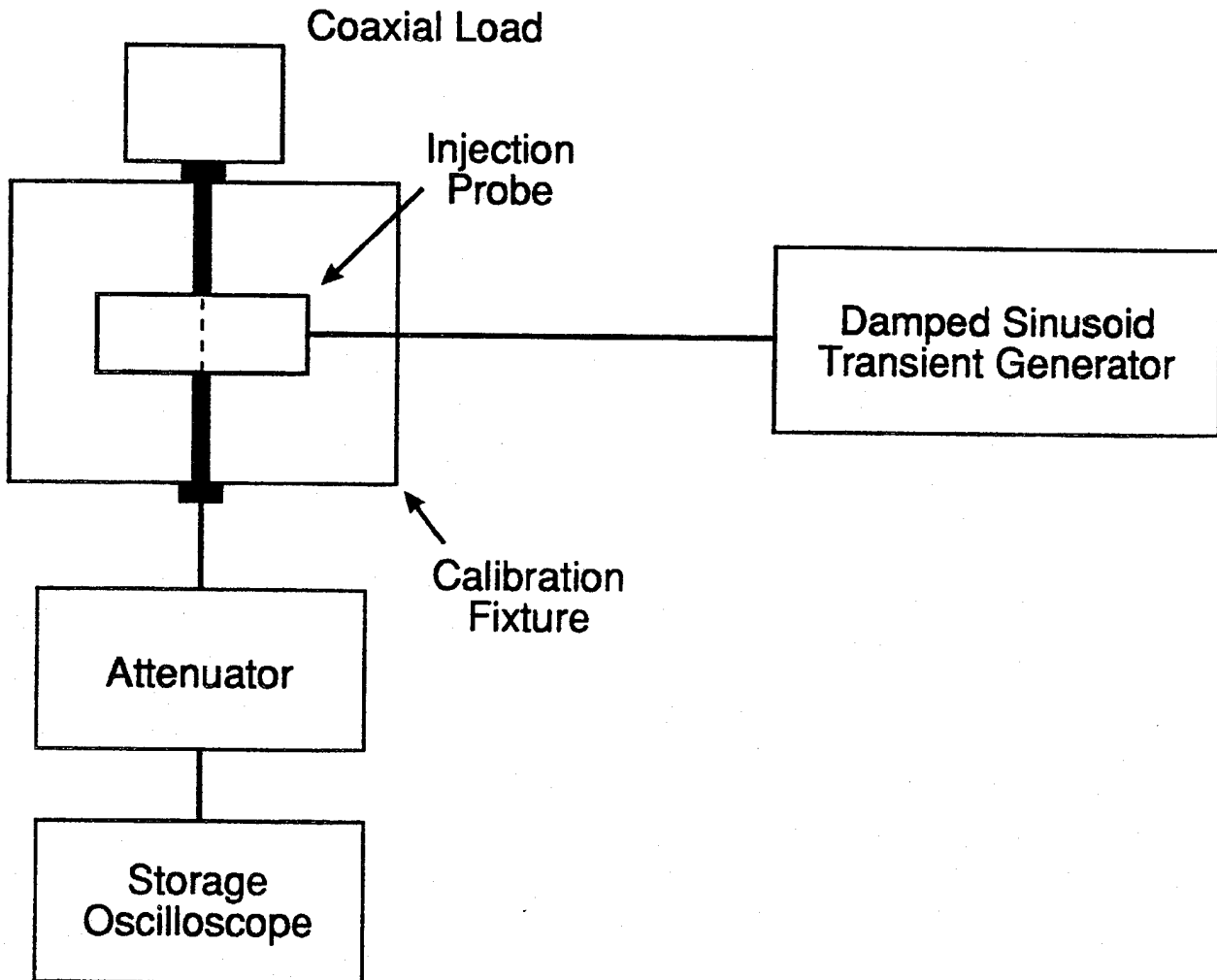

FIGURE CS116-1. Typical test setup for calibration of test waveform.

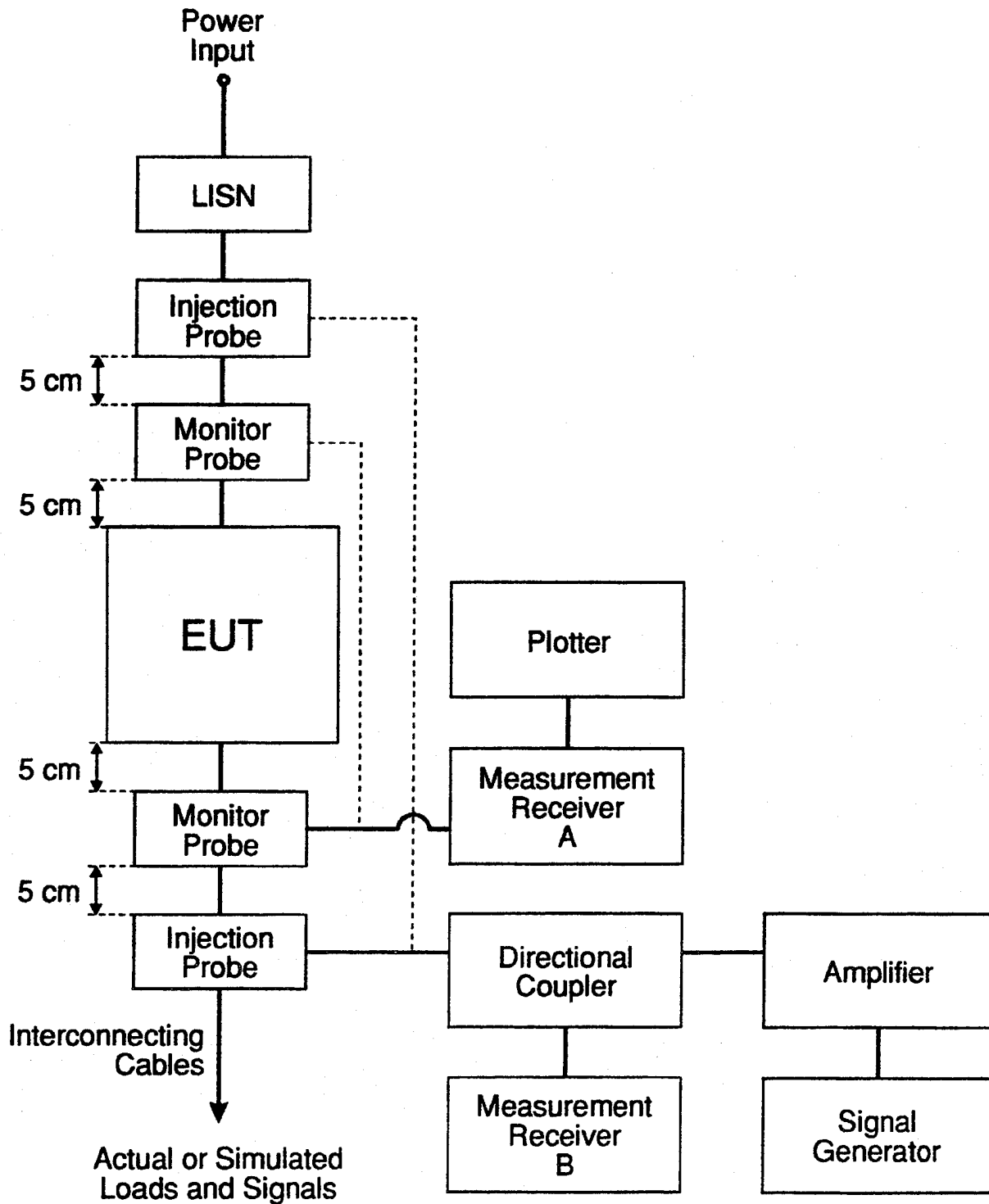

FIGURE CS116-2. Loop circuit impedance characterization.

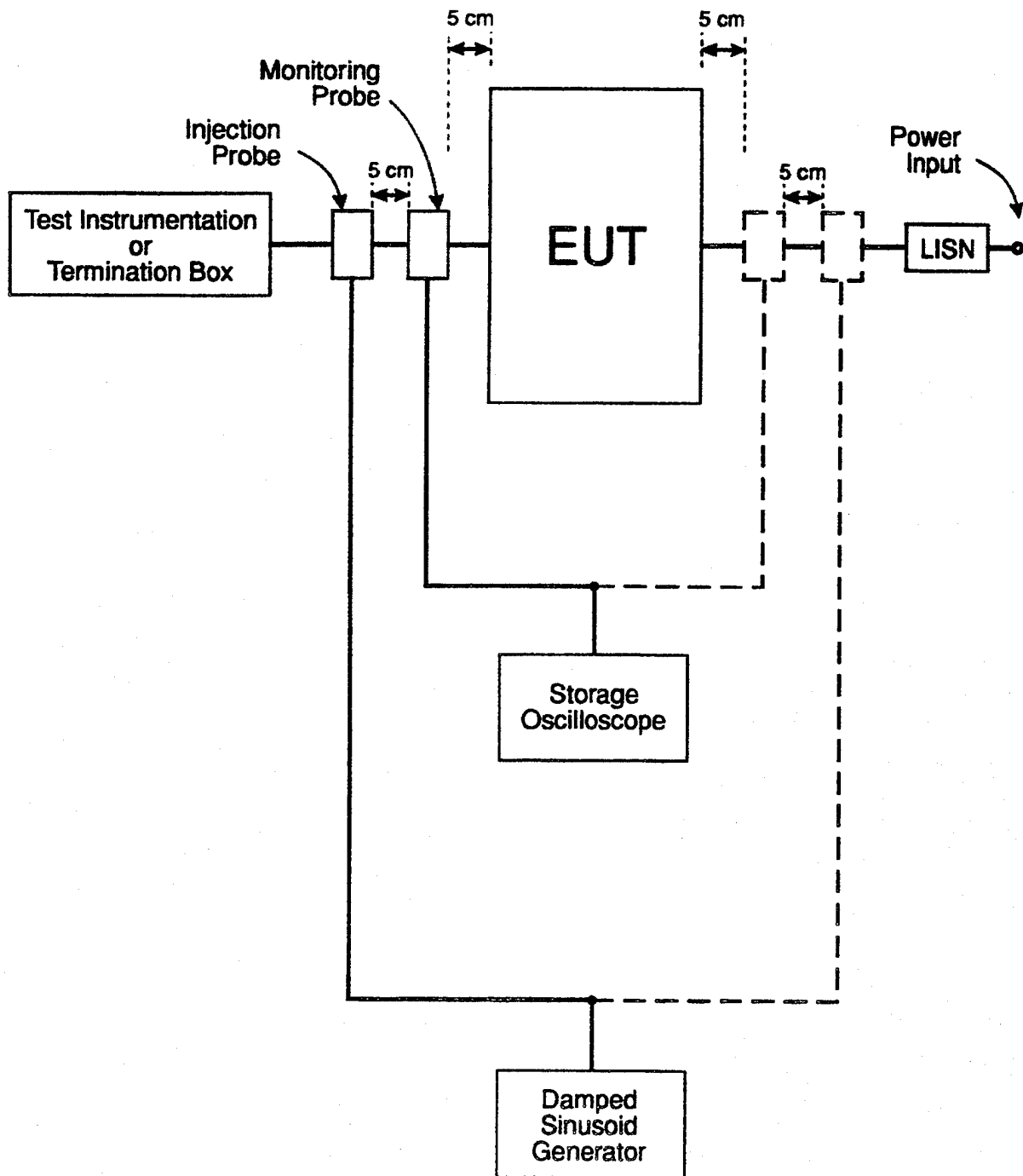

FIGURE CS116-3. Typical set up for bulk cable injection of damped sinusoidal transients.

METHOD RE101

RADIATED EMISSIONS, MAGNETIC FIELD, 30 Hz TO 100 kHz

1. Purpose. This test method is to verify that the magnetic field emissions from the EUT and its associated cabling do not exceed specified requirements.

2. Test Equipment. The test equipment shall be as follows:

a. Measurement receivers

b. Data recording device

c. Loop sensor having the following specifications:

- (1) Diameter: 13.3 cm
- (2) Number of turns: 36
- (3) Wire: 7-41 Litz (7 strand, No. 41 AWG)
- (4) Shielding: Electrostatic
- (5) Correction factor: To convert measurement receiver readings expressed in decibels above one microvolt (dB μ V) to decibels above one picotesla (dBpT), add the factor shown in Figure RE101-1.

d. LISNs

3. Test Setup. The test setup shall be as follows:

a. Maintain a basic test setup for the EUT as shown and described in Figures 2 through 5 and paragraph 4.8 of the general section of this standard.

b. Calibration. Configure the measurement setup as shown in Figure RE101-2.

c. EUT Testing. Configure the measurement receiving loop and EUT as shown in Figure RE101-3.

4. Test Procedures. The test procedures shall be as follows:
- a. Turn on the measurement equipment and allow sufficient time for stabilization.
 - b. Calibration.
 - (1) Apply a calibrated signal level, which is 6 dB below the MIL-STD-461 limit, at a frequency of 50 kHz. Tune the measurement receiver to a center frequency of 50 kHz. Record the measured level.
 - (2) Verify that the measurement receiver indicates a level within ± 3 dB of the injected signal level.
 - (3) If readings are obtained which deviate by more than ± 3 dB, locate the source of the error and correct the deficiency prior to proceeding with the testing.
 - c. EUT Testing.
 - (1) Turn on the EUT and allow sufficient time for stabilization.
 - (2) Locate the loop sensor 7 cm from the EUT face or cable being probed. Orient the plane of the loop sensor parallel to the EUT faces and parallel to the axis of cables.
 - (3) Scan the measurement receiver over the applicable frequency range to locate the frequencies of maximum radiation, using the bandwidths and minimum measurement times of the general section of this standard.
 - (4) Tune the measurement receiver to one of the frequencies or band of frequencies identified in 4c(3) above.
 - (5) Monitor the output of the measurement receiver while moving the loop sensor (maintaining the 7 cm spacing) over the face of the EUT or along the cable. Note the point of maximum radiation for each frequency identified in 4c(4).
 - (6) At 7 cm from the point of maximum radiation, orient the plane of the loop sensor to give a maximum

reading on the measurement receiver and record the reading.

- (7) Move the loop sensor away from the EUT face or the cable being probed to a distance of 50 cm and record the reading on the measurement receiver.
- (8) Repeat 4c(4) through 4c(7) for at least two frequencies of maximum radiation per octave of frequencies below 200 Hz and for at least three frequencies of maximum radiation per octave above 200 Hz.
- (9) Repeat 4c(2) through 4c(8) for each face of the EUT and for each cable connected to the EUT.

5. Data Presentation. Data presentation shall be as follows:

- a. Provide graphs or a tabular listing of each measurement frequency, mode of operation, distance from the EUT, measured magnetic field, and magnetic field limit level for both the 7 cm and 50 cm distances.

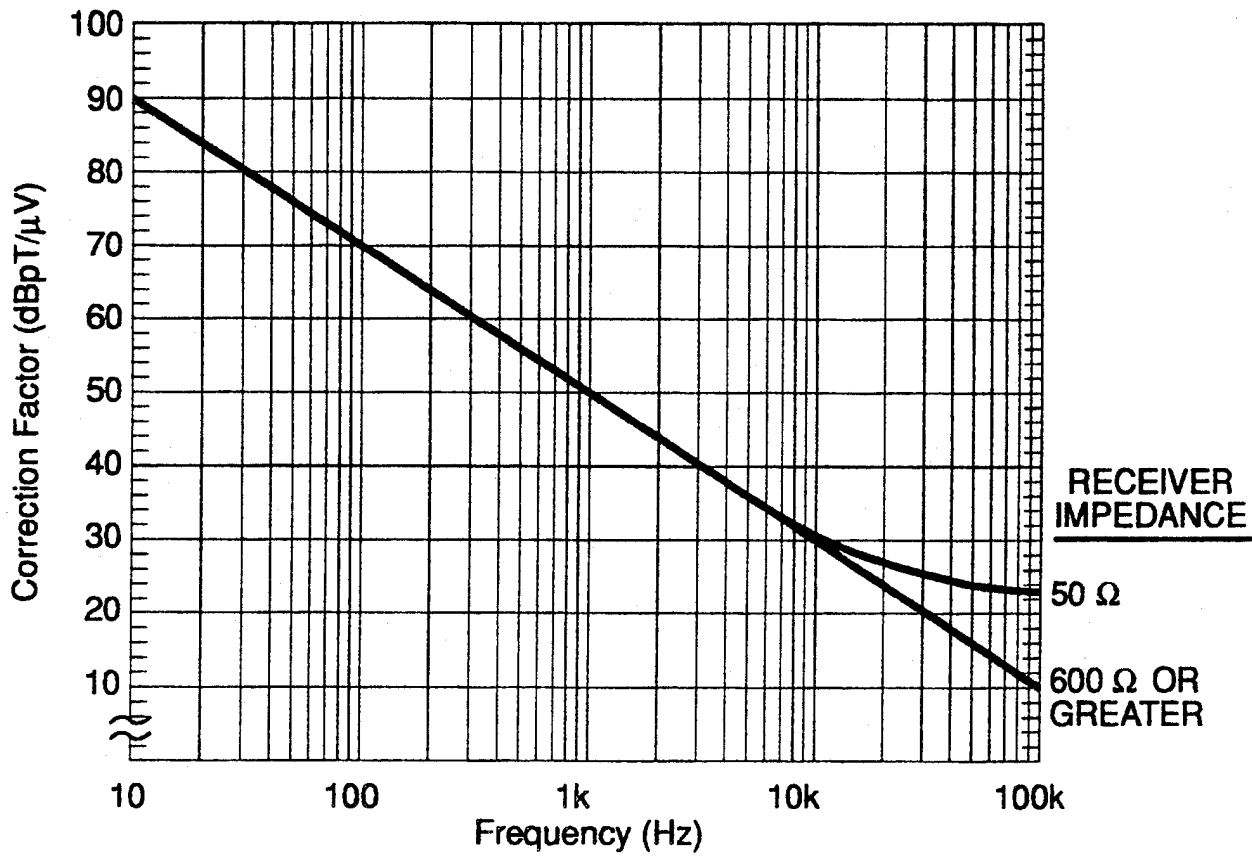

FIGURE RE101-1. Loop sensor correction factor.

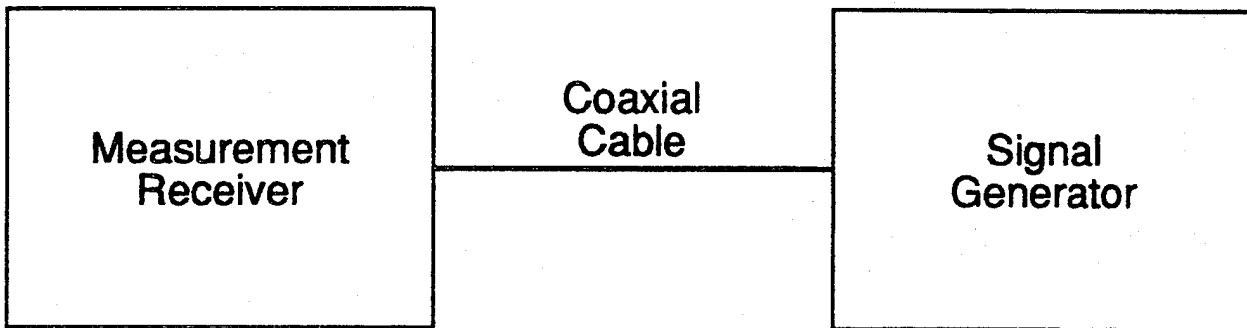

FIGURE RE101-2. Calibration configuration.

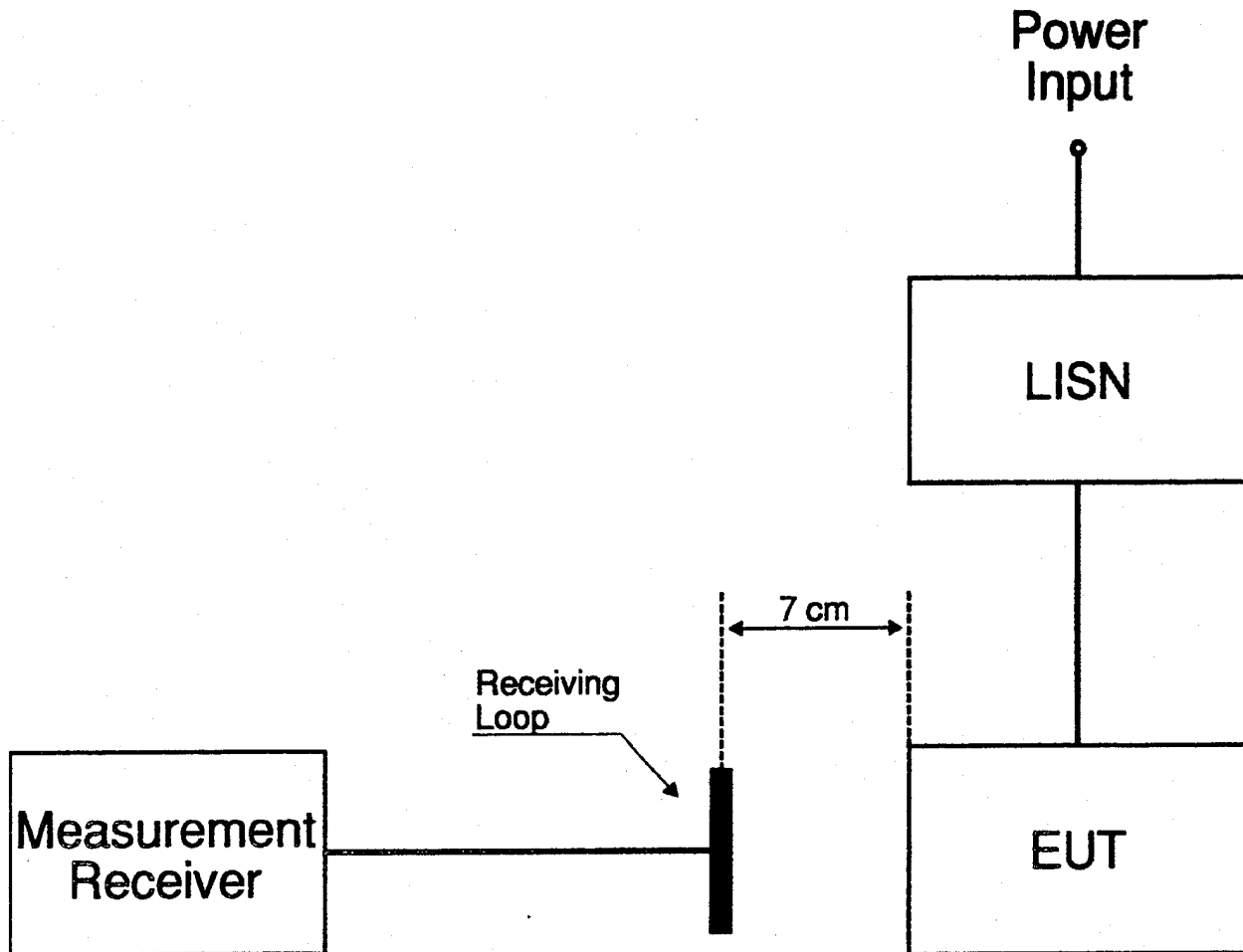

FIGURE RE101-3. Typical Test Setup for Radiated Emissions, Magnetic Field, 30 Hz to 100 kHz.

METHOD RE102

RADIATED EMISSIONS, ELECTRIC FIELD, 10 kHz TO 18 GHz

1. Purpose. This test method is used to verify that electric field emissions from the EUT and its associated cabling do not exceed specified requirements.

2. Test Equipment. The test equipment shall be as follows:

a. Measurement receivers

b. Data recording device

c. Antennas

(1) 10 kHz to 30 MHz, 104 cm rod with impedance matching network

(a) When the impedance matching network includes a preamplifier (active rod), observe the overload precautions in 4.7.3 of the general section of this standard.

(b) Use a square counterpoise measuring at least 60 cm on a side.

(2) 30 MHz to 200 MHz, Biconical, 137 cm tip to tip

(3) 200 MHz to 18 GHz, Double ridge horns

d. Signal generators

e. Stub radiator

f. Capacitor, 10 pF

g. LISNs

3. Test Setup. The test setup shall be as follows:

a. Maintain a basic test setup for the EUT as shown and described in Figures 1 through 5 and paragraph 4.8 of the general section of this standard. Ensure that the EUT is oriented such that the surface which produces the maximum radiated emissions is toward the measurement antenna.

- b. Calibration. Configure the test equipment as shown in Figure RE102-1.
- c. EUT testing.
- (1) For shielded room measurements, electrically bond the rod antenna counterpoise to the ground plane using a solid metal sheet the same width as the counterpoise. The maximum DC resistance between the counterpoise and the ground plane shall be 2.5 milliohms. For bench top setups using a metallic ground plane, bond the counterpoise to this ground plane. Otherwise, bond the counterpoise to the floor ground plane. For measurements outside a shielded enclosure, electrically bond the counterpoise to earth ground.
 - (2) Antenna Positioning.
 - (a) Determine the test setup boundary of the EUT and associated cabling for use in positioning of antennas.
 - (b) Use the physical reference points on the antennas shown in Figure RE102-2 for measuring heights of the antennas and distances of the antennas from the test setup boundary.
 1. Position antennas 1 meter from the front edge of the test setup boundary for all setups.
 2. Position antennas other than the 104 cm rod antenna 120 cm above the floor ground plane.
 3. Insure that no part of any antenna is closer than 1 meter from the walls and 0.5 meter from the ceiling of the shielded enclosure.
 4. For test setups using bench tops, additional positioning requirements for the rod antenna and distance above the bench ground plane are shown in Figure RE102-2.
 5. For free standing setups, electrically bond and mount the 104 cm rod antenna matching network to the floor ground plane without a separate counterpoise.

- (c) The number of required antenna positions depends on the size of the test setup boundary and the number of enclosures included in the setup.
1. For testing below 200 MHz, use the following criteria to determine the individual antenna positions.
 - a. For setups with the side edges of the boundary 3 meters or less, one position is required and the antenna shall be centered with respect to the side edges of the boundary.
 - b. For setups with the side edges of the boundary greater than 3 meters, use multiple antenna positions at spacings as shown in Figure RE102-3. Determine the number of antenna positions (N) by dividing the edge-to-edge boundary distance (in meters) by 3 and rounding up to an integer.
 2. For testing from 200 MHz up to 1 GHz, place the antenna in a sufficient number of positions such that the entire width of each EUT enclosure and the first 35 cm of cables and leads interfacing with the EUT enclosure are within the 3 dB beamwidth of the antenna.
 3. For testing at 1 GHz and above, place the antenna in a sufficient number of positions such that the entire width of each EUT enclosure and the first 7 cm of cables and leads interfacing with the EUT enclosure are within the 3 dB beamwidth of the antenna.
4. Test Procedures. The test procedures shall be as follows:
- a. Verify that the ambient requirements specified in 4.4 of the general section of this standard are met. Take plots of the ambient when required by the referenced paragraph.
 - b. Turn on the measurement equipment and allow a sufficient time for stabilization.
 - c. Using the system check path of Figure RE102-1, perform the following evaluation of the overall measurement

system from each antenna to the data output device at the highest measurement frequency of the antenna. For rod antennas that use passive matching networks, the evaluation shall be performed at the center frequency of each band.

- (1) Apply a calibrated signal level, which is 6 dB below the MIL-STD-461 limit (limit minus antenna factor), to the coaxial cable at the antenna connection point.
 - (2) Scan the measurement receiver in the same manner as a normal data scan. Verify that the data recording device indicates a level within ± 3 dB of the injected signal level.
 - (3) For the 104 cm rod antenna, remove the rod element and apply the signal to the antenna matching network through a 10 pF capacitor connected to the rod mount.
 - (4) If readings are obtained which deviate by more than ± 3 dB, locate the source of the error and correct the deficiency prior to proceeding with the testing.
- d. Using the measurement path of Figure RE102-1, perform the following evaluation for each antenna to demonstrate that there is electrical continuity through the antenna.
- (1) Radiate a signal using an antenna or stub radiator at the highest measurement frequency of each antenna.
 - (2) Tune the measurement receiver to the frequency of the applied signal and verify that a received signal of appropriate amplitude is present.
- e. Turn on the EUT and allow sufficient time for stabilization.
- f. Using the measurement path of Figure RE102-1, determine the radiated emissions from the EUT and its associated cabling.
- (1) Scan the measurement receiver for each applicable frequency range, using the bandwidths and minimum measurement times in the general section of this standard.
 - (2) Above 30 MHz, orient the antennas for both horizontally and vertically polarized fields.

- (3) Take measurements for each antenna position determined under 3c(2) (c) above.

5. Data Presentation. Data presentation shall be as follows:

- a. Continuously and automatically plot amplitude versus frequency profiles. Manually gathered data is not acceptable except for plot verification.
- b. Display the applicable limit on each plot.
- c. Provide a minimum frequency resolution of 1% or twice the measurement receiver bandwidth, whichever is less stringent, and a minimum amplitude resolution of 1 dB for each plot.
- d. Provide plots for both the measurement and system check portions of the procedure.
- e. Provide a statement verifying the electrical continuity of the measurement antennas as determined in 4d.

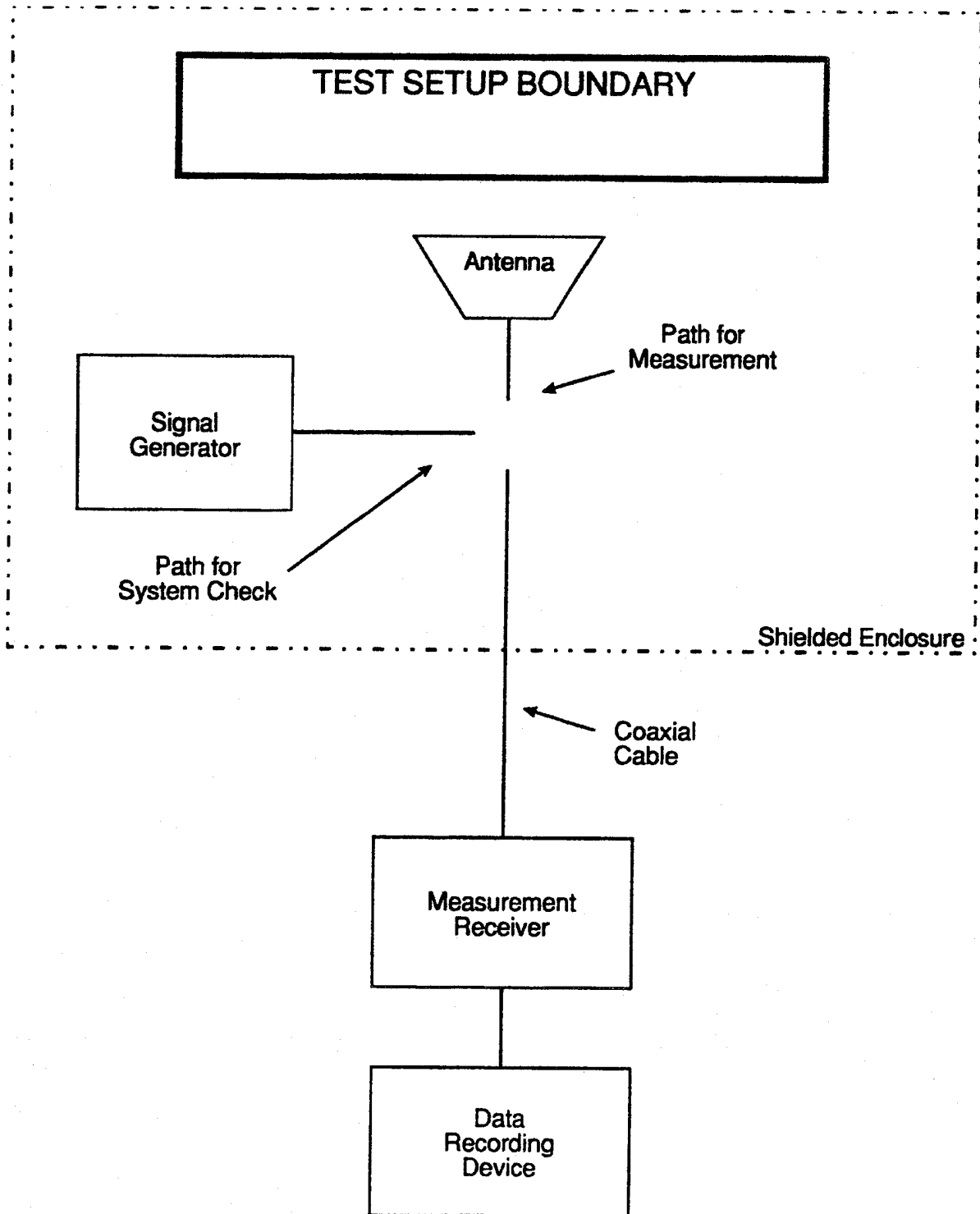

FIGURE RE102-1. Basic test setup.

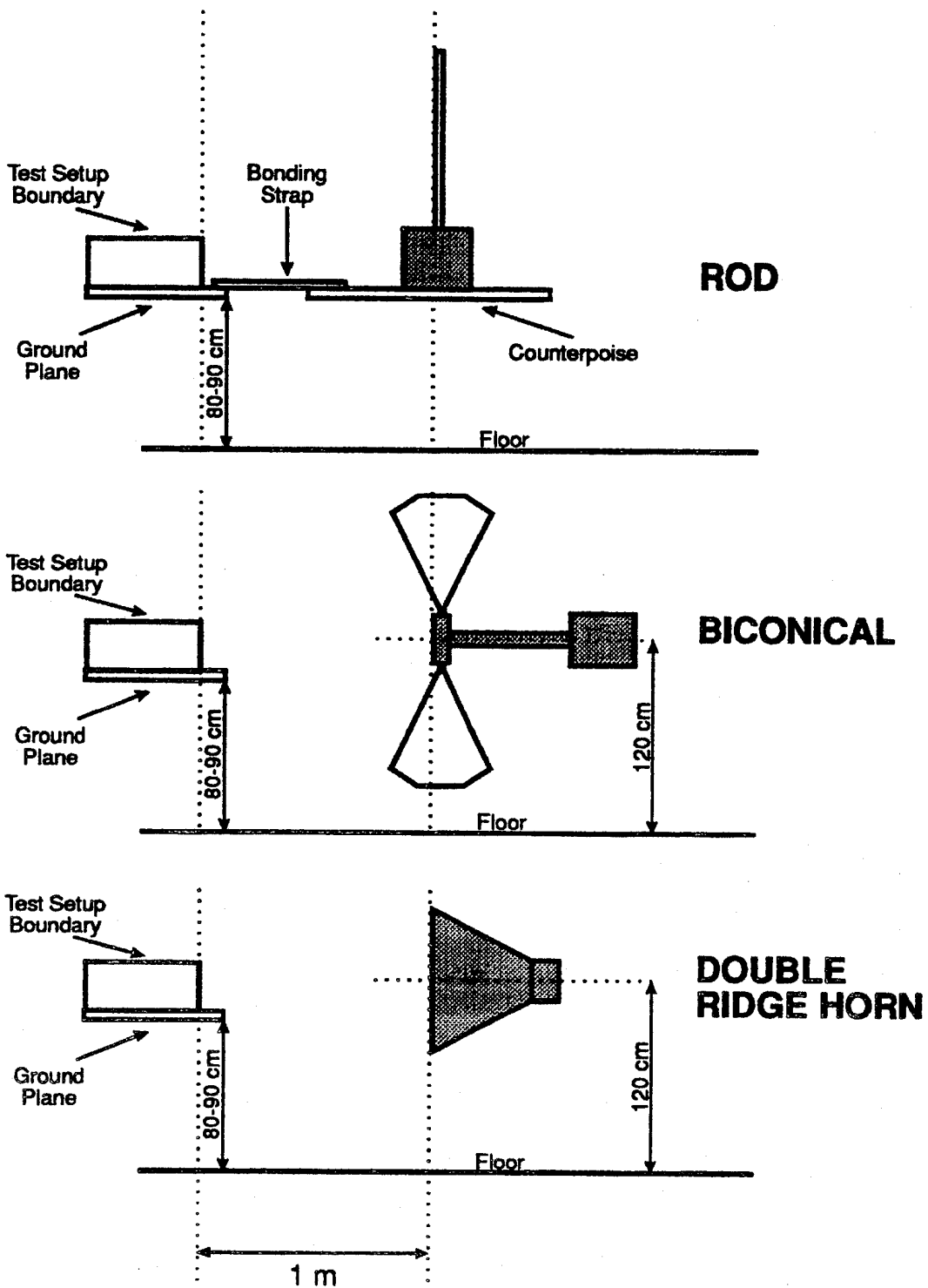

FIGURE RE102-2. Antenna positioning.

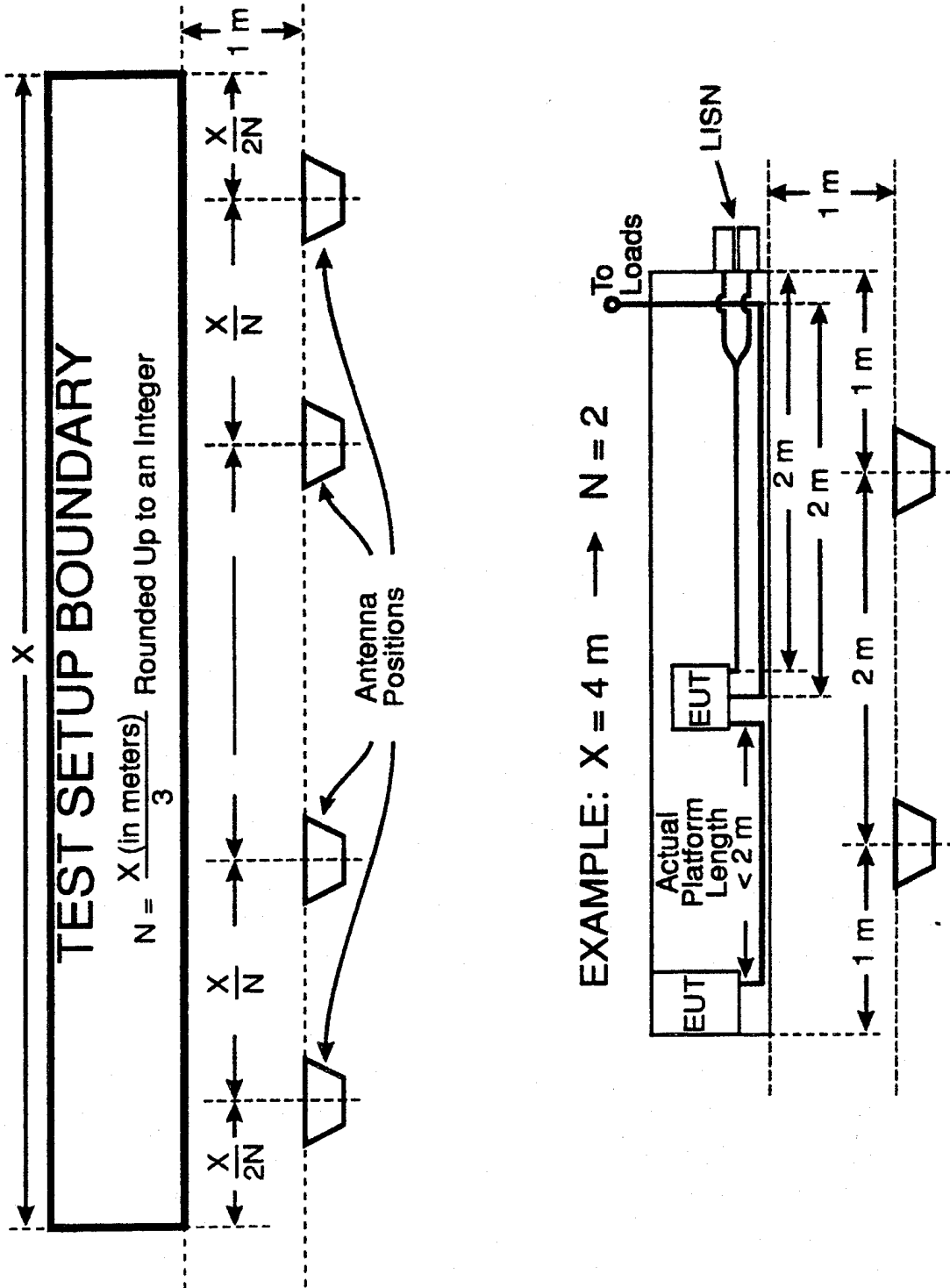

FIGURE RE102-3. Multiple antenna positions.

METHOD RE103

RADIATED EMISSIONS, ANTENNA SPURIOUS AND HARMONIC OUTPUTS,
10 kHz TO 40 GHz

1. Purpose. This test method is used to verify that radiated spurious and harmonic emissions from transmitters do not exceed the specified requirements.
2. Test Equipment. The test equipment shall be as follows:
 - a. Measurement receiver
 - b. Attenuators
 - c. Antennas
 - d. Rejection networks
 - e. Signal generators
 - f. Power monitor
3. Test Setup. It is not necessary to maintain the basic test setup for the EUT as shown and described in figures 1 through 5 and paragraph 4.8 of the general section of this standard. The test setup shall be as follows:
 - a. Calibration. Configure the test setup for the signal check path shown in Figure RE103-1 or RE103-2 as applicable.
 - b. EUT Testing. Configure the test setup for the measurement path shown in Figure RE103-1 or RE103-2 as applicable.
4. Test Procedures. The test procedures shall be as follows:
 - a. The measurements must be performed in the far-field of the transmitting frequency. Consequently, the far-field test distance must be calculated prior to performing the test using the relationships below:

R = distance between transmitter antenna and receiver antenna.
 D = maximum physical dimension of transmitter antenna.
 d = maximum physical dimension of receiver antenna.
 λ = wavelength of frequency of the transmitter.

All dimensions are in meters.

For transmitter frequencies less than or equal to 1.24 GHz, the greater distance of the following relationships shall be used:

$$R = 2D^2/\lambda$$

$$R = 3\lambda$$

For transmitter frequencies greater than 1.24 GHz, the separation distance shall be calculated as follows:

For $2.5 D < d$	use	$R = 2D^2/\lambda$
For $2.5 D \geq d$	use	$R = (D+d)^2/\lambda$

- b. Turn on the measurement equipment and allow sufficient time for stabilization.
- c. Calibration.
 - (1) Apply a known calibrated signal level from the signal generator through the system check path at a midband fundamental frequency (f_0) in accordance with the general section of this standard.
 - (2) Scan the measurement receiver in the same manner as a normal data scan. Verify the measurement receiver detects a level within ± 3 dB of the expected signal.
 - (3) If readings are obtained which deviate by more than ± 3 dB, locate the source of the error and correct the deficiency prior to proceeding with the test.
 - (4) Repeat 4c(1) through 4c(3) for two other frequencies over the frequency range of test.
- d. EUT Testing.
 - (1) Turn on the EUT and allow a sufficient time for stabilization.

- (2) Tune the EUT to the desired test frequency and use the measurement path to complete the rest of this procedure.
- (3) Tune the test equipment to the measurement frequency (f_0) of the EUT and adjust for maximum indication.
- (4) Measure the modulated transmitter power output P, using a power monitor while keying the transmitter. Convert this power level to units of dB relative to 1 watt (dBW). Calculate the Effective Radiated Power (ERP) by adding the EUT antenna gain to this value. Record the resulting level for comparison with that obtained in 4d(6).
- (5) Key the transmitter with desired modulation. Tune the measurement receiver for maximum output indication at the transmitted frequency. If either or both of the antennas have directivity, align both in elevation and azimuth for maximum indication. Verbal communication between sites via radiotelephone will facilitate this process. Record the resulting maximum receiver meter reading and the measurement receiver bandwidth.
- (6) Calculate the transmitter ERP in dBW, based on the receiver meter reading V, using the following equation:

$$\text{ERP} = V + 20 \log R + \text{AF} - 135$$

where:

V = reading on the measurement receiver in dB μ V

R = distance between transmitter and receiver antennas in meters

AF= antenna factor of receiver antenna in dB (1/m)

Compare this calculated level to the measured level recorded in 4d(4). The compared results should agree within ± 3 dB. If the difference exceeds ± 3 dB, check the test setup for errors in measurement distance, amplitude calibration, power monitoring of the transmitter, frequency tuning or drift and antenna boresight alignment. Assuming that the results are within the ± 3 dB tolerance, the ERP becomes the reference for which amplitudes of spurious and harmonics will be compared to determine compliance with standard limits.

- (7) With the rejection network filter connected and tuned to f_0 , scan the measurement receiver over the frequency range of test to locate spurious and harmonic transmitted outputs. It may be necessary to move the measuring system antenna in elevation and azimuth at each spurious and harmonic output to assure maximum levels are recorded. Maintain the same measurement receiver bandwidth used to measure the fundamental frequency in 4d(5).
 - (8) Verify that spurious outputs are from the EUT and not spurious responses of the measurement system or the test site ambient.
 - (9) Calculate the ERP of each spurious output. Include all correction factors for cable loss, amplifier gains, filter loss, and attenuator factors.
 - (10) Repeat 4d(2) through 4d(9) for other f_0 of the EUT.
5. Data Presentation. Data presentation shall be as follows:
- a. Provide tabular data showing fundamental frequency (f_0) and frequency of all harmonics and spurious emissions measured, the measured power monitor level and the calculated ERP of the fundamental frequency, the ERP of all spurious and harmonics emissions measured, dB down levels, and all correction factors including cable loss, attenuator pads, amplifier gains, insertion loss of rejection networks and antenna gains.
 - b. The relative dB down level is determined by subtracting the level in 4d(6) from that recorded in 4d(9).

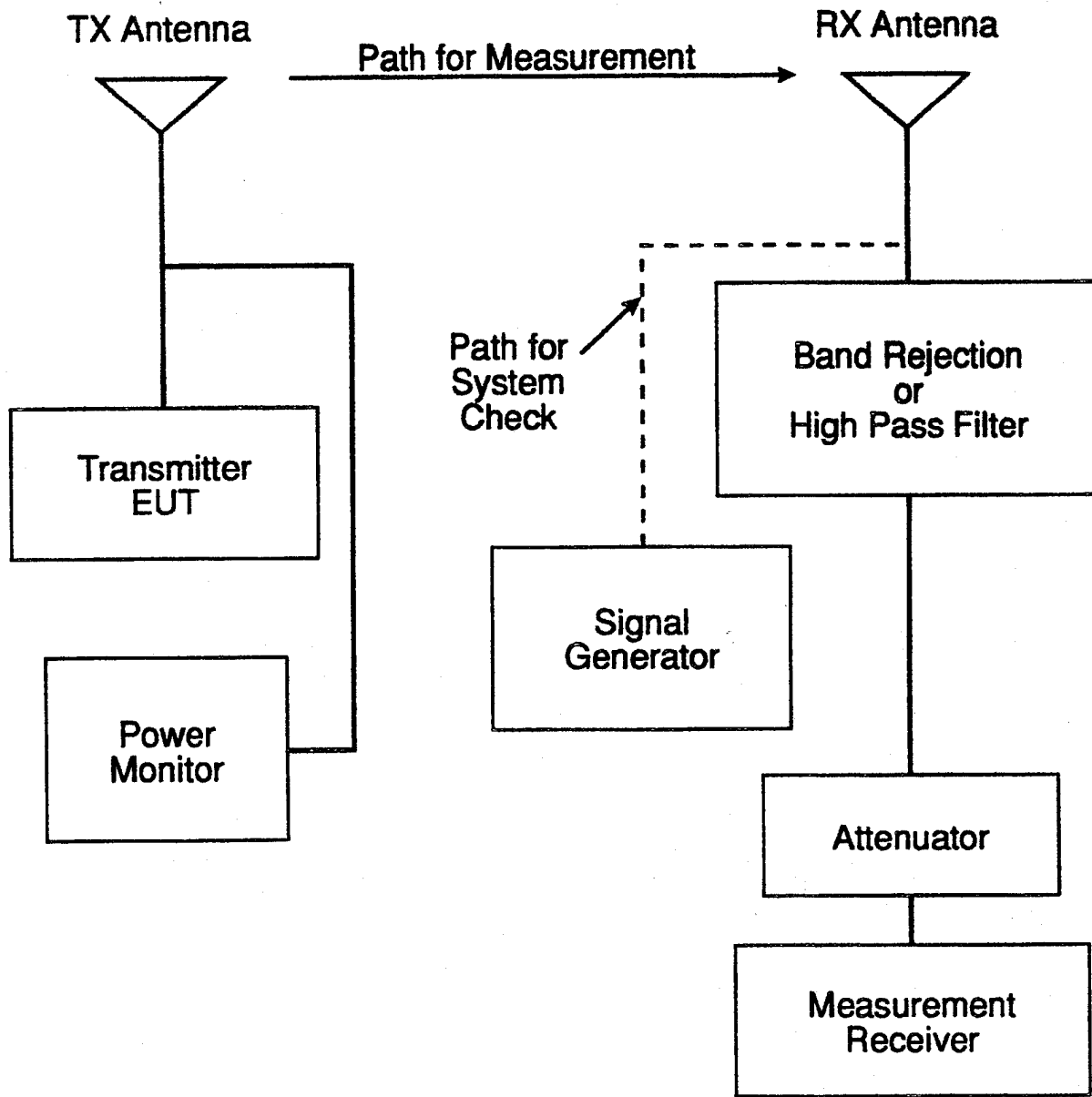

FIGURE RE103-1. Calibration and test setup for radiated harmonics and spurious emissions, 10 kHz to 1 GHz.

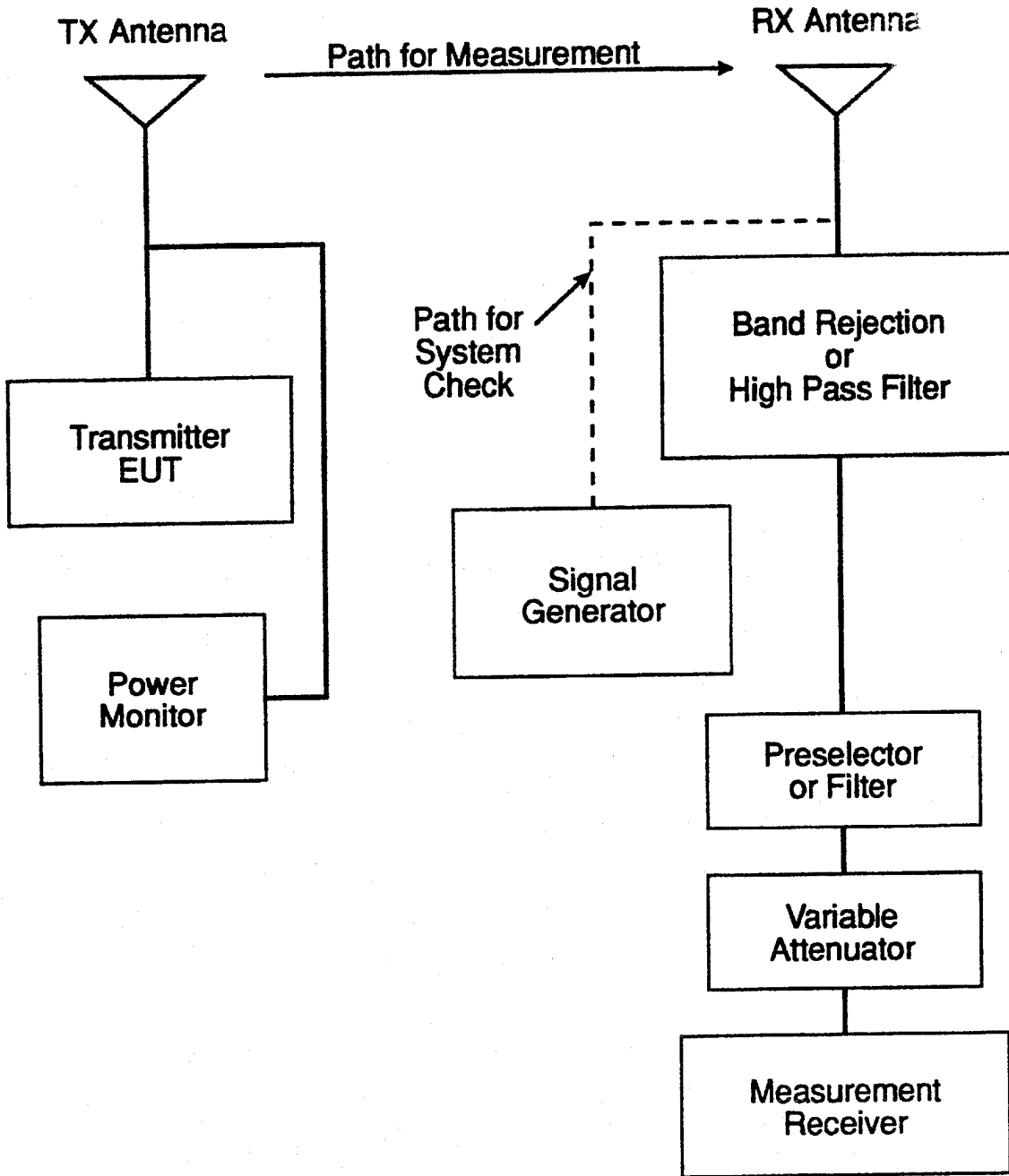

FIGURE RE103-2. Calibration and test setup for radiated harmonics and spurious emissions, 1 GHz to 40 GHz.

METHOD RS101

RADIATED SUSCEPTIBILITY, MAGNETIC FIELD, 30 Hz TO 100 kHz

1. Purpose. This test method is to verify the ability of the EUT to withstand radiated magnetic fields.

2. Test Equipment. The test equipment shall be as follows:

a. Signal source

b. Radiating loop having the following specifications:

(1) Diameter: 12 cm

(2) Number of turns: 20

(3) Wire: No. 12 insulated copper

(4) Magnetic flux density: 9.5×10^7 pT/ampere of applied current at a distance of 5 cm from the plane of the loop.

c. Loop sensor having the following specifications:

(1) Diameter: 4 cm

(2) Number of turns: 51

(3) Wire: 7-41 Litz (7 Strand, No. 41 AWG)

(4) Shielding: Electrostatic

(5) Correction Factor: To convert measurement receiver readings expressed in decibels above one microvolt (dB μ V) to decibels above one picotesla (dBpT), add the factor shown in figure RS101-1.

d. Measurement receiver or narrowband voltmeter

e. Current probe

f. LISNs

3. Test Setup. The test setup shall be as follows:

a. Maintain a basic test setup for the EUT as shown and described in Figures 2 through 5 and paragraph 4.8 of the general section of this standard.

b. Calibration.

(1) Configure the measurement equipment, radiating loop, and loop sensor as shown in Figure RS101-2.

c. EUT Testing.

(1) Configure the test as shown in Figure RS101-3.

4. Test Procedures. The test procedures shall be as follows:

a. Turn on the measurement equipment and allow sufficient time for stabilization.

b. Calibration.

(1) Set the signal source to a frequency of 1 kHz and adjust the output to provide a magnetic flux density of 110 dB above one picotesla as determined by the reading obtained on measurement receiver A and the relationship given in 2b(4).

(2) Measure the voltage output from the loop sensor.

(3) Verify that the output on measurement receiver B is 42 dB μ V \pm 3 dB and record this value in the appropriate space on the data sheet.

c. EUT Testing.

(1) Turn on the EUT and allow sufficient time for stabilization.

(2) Select test frequencies as follows:

(a) Position the radiating loop 5 cm from one face of the EUT. The plane of the loop shall be parallel to the plane of the EUT's surface.

(b) Supply the loop with sufficient current to produce magnetic field strengths at least 10 dB

greater than the applicable limit in MIL-STD-461 but not to exceed 15 amps (183 dBpT).

- (c) Scan the applicable frequency range specified in MIL-STD-461. Scan rates up to 3 times faster than the rates specified in Table III are acceptable.
 - (d) If susceptibility is noted, select no less than three test frequencies per octave at those frequencies where the maximum indications of susceptibility are present.
 - (e) Reposition the loop successively to a location in each 30 by 30 cm area on each face of the EUT and at each electrical interface connector, and repeat 4c(2)(c) and 4c(2)(d) to determine locations and frequencies of susceptibility.
 - (f) From the total frequency data where susceptibility was noted in 4c(2)(c) through 4c(2)(e), select three frequencies per octave over the applicable frequency range in MIL-STD-461.
- (3) At each frequency determined in 4c(2)(f), apply a current to the radiating loop that corresponds to the applicable limit in MIL-STD-461. Move the loop to search for possible locations of susceptibility with particular attention given to the locations determined in 4c(2)(e) while maintaining the loop 5 cm from the EUT surface, cable, or connector. Verify that susceptibility is not present.

5. Data Presentation. Data presentation shall be as follows:

- a. Provide tabular data showing verification of the calibration of the radiating loop in 4a.
- b. Provide tabular data, diagrams, or photographs showing the applicable test frequencies and locations determined in 4c(2)(e) and 4c(2)(f).
- c. Provide graphical or tabular data showing frequencies and threshold levels of susceptibility.

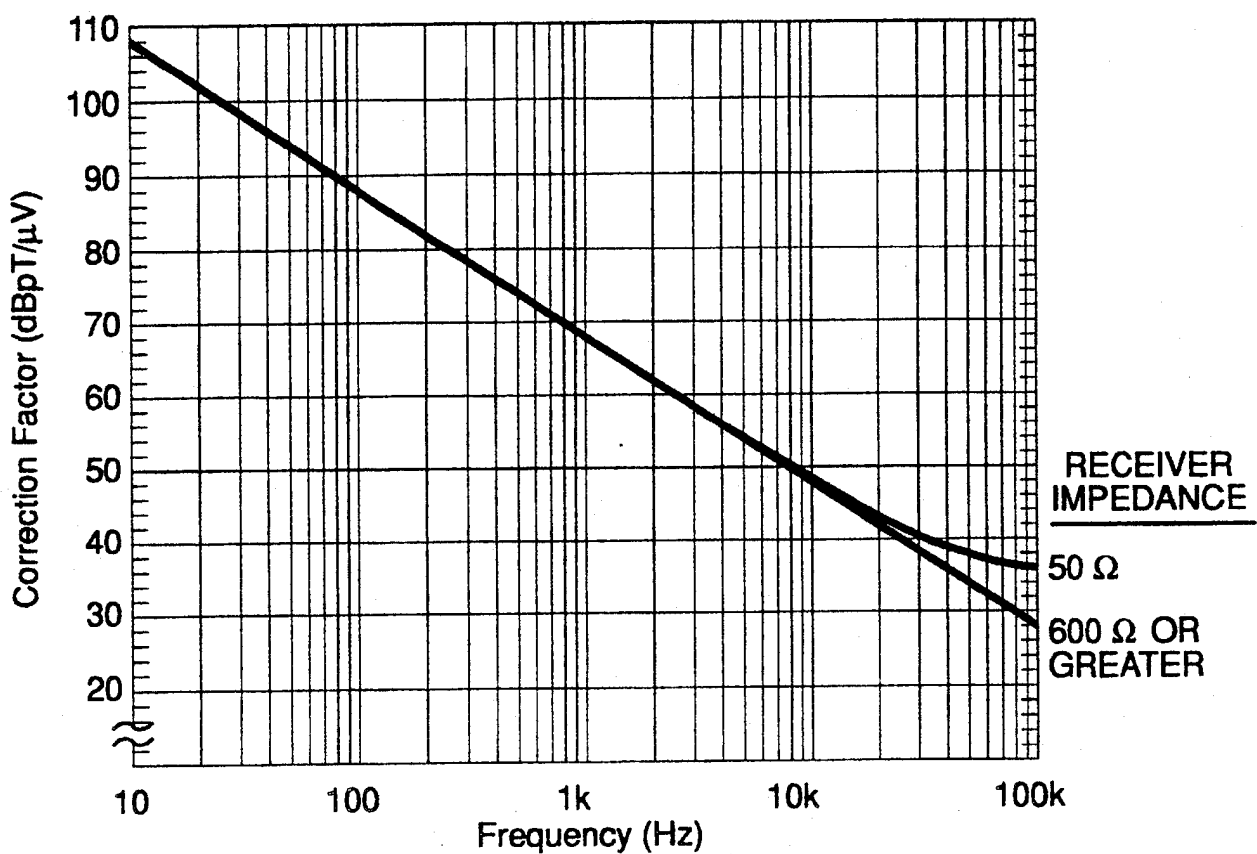

FIGURE RS101-1. Loop sensor correction factor.

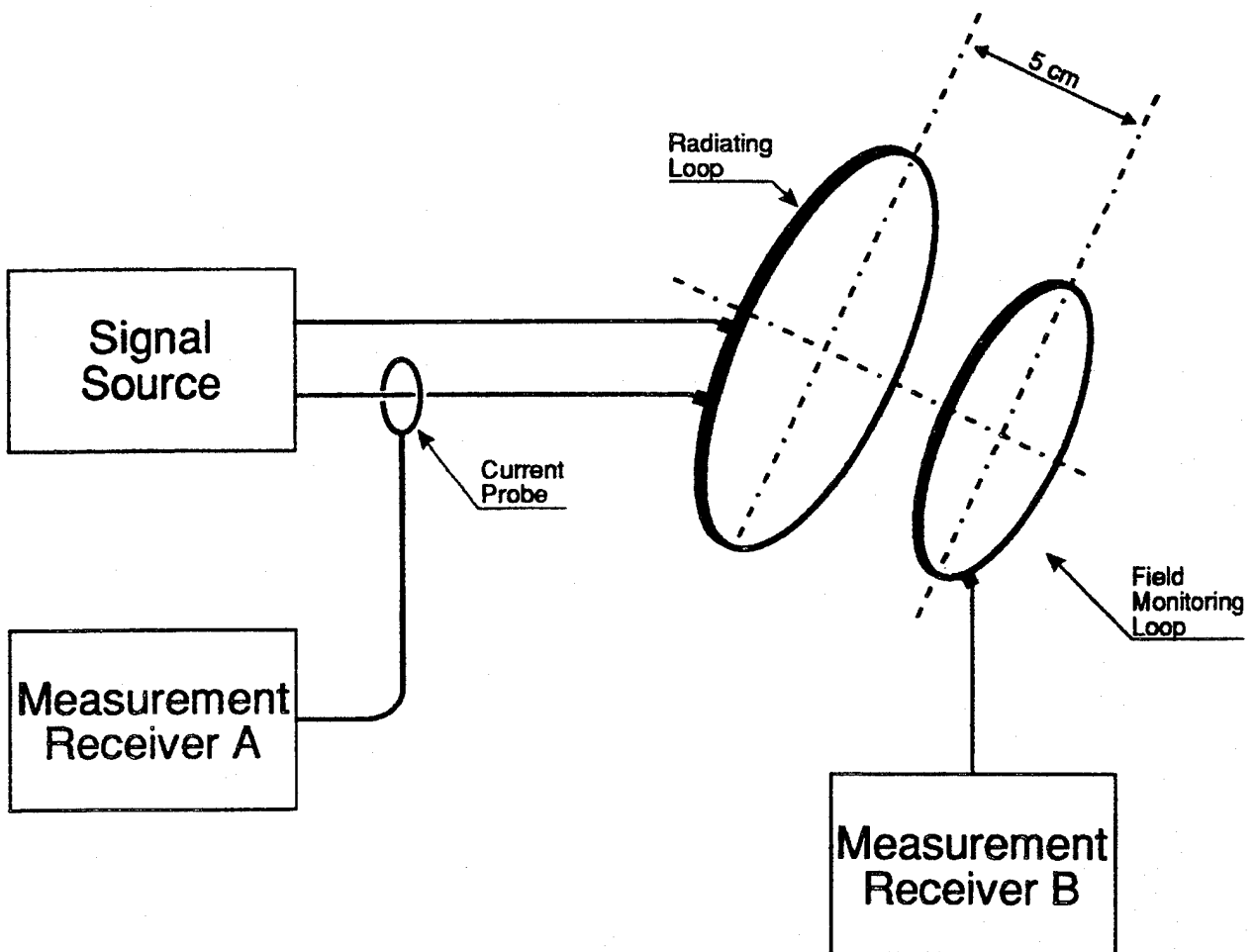

FIGURE RS101-2. Calibration of the radiating system.

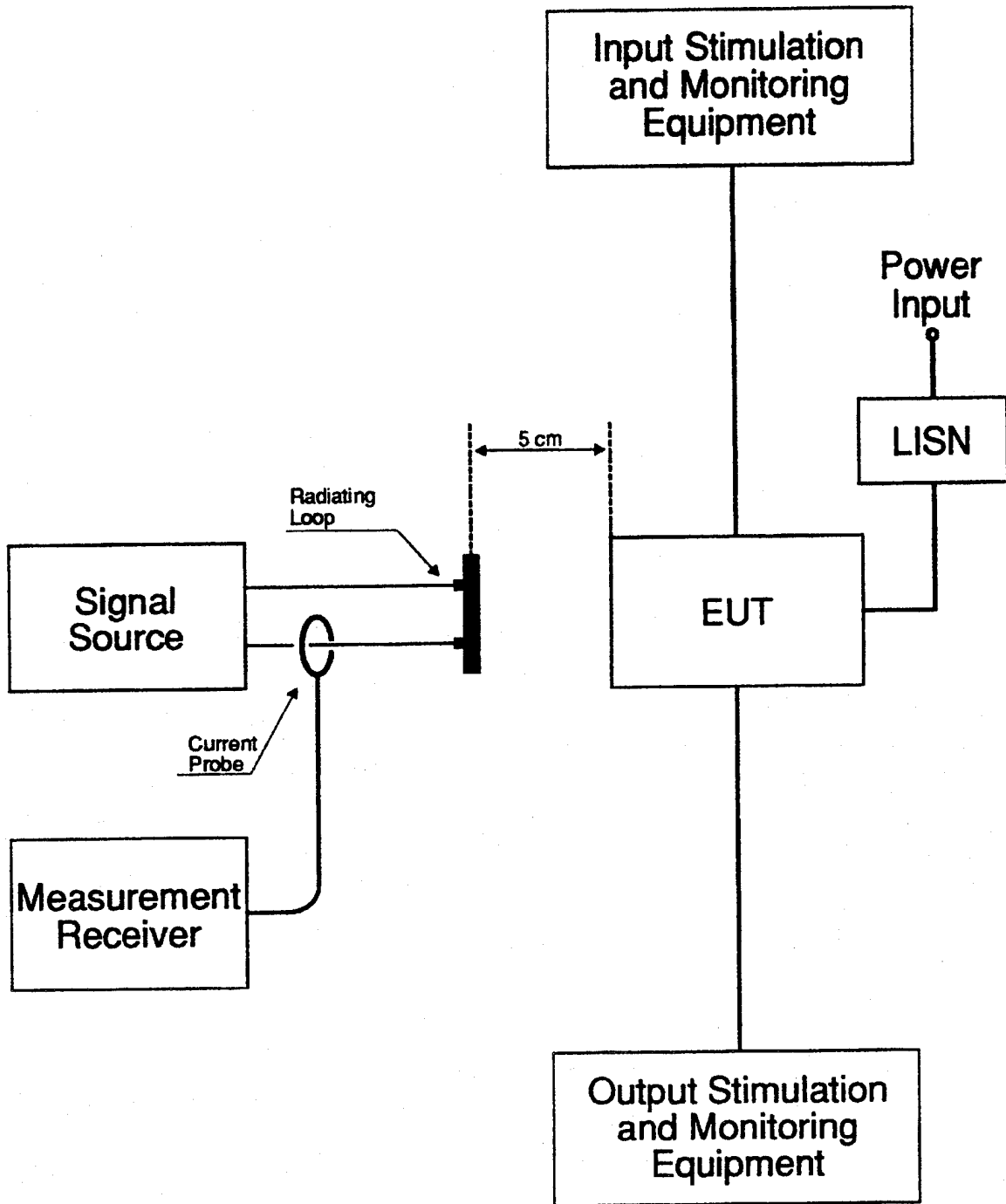

FIGURE RS101-3. Typical test setup for radiated susceptibility. Magnetic field, 30 Hz to 50 kHz.

METHOD RS103

RADIATED SUSCEPTIBILITY, ELECTRIC FIELD, 10 kHz TO 40 GHz

1. Purpose. This test method is used to verify the ability of the EUT and associated cabling to withstand electric fields.
2. Test Equipment. The test equipment shall be as follows:
 - a. Signal generators
 - b. Power amplifiers
 - c. Receive antennas
 - (1) 1 GHz to 10 GHz, double ridge horns
 - (2) 10 GHz to 40 GHz, other antennas as approved by the procuring activity
 - d. Transmit antennas
 - e. Electric field sensors (physically small - electrically short)
 - f. Measurement receiver
 - g. Power meter
 - h. Directional coupler
 - i. Attenuator
 - j. Data recording device
 - k. LISNs
3. Test Setup. The test setup shall be as follows:
 - a. Maintain a basic test setup for the EUT as shown and described in Figures 1 through 5 and paragraph 4.8 of the general section of this standard.
 - b. For electric field calibration, electric field sensors are required from 10 kHz to 1 GHz. Either field sensors or receive antennas may be used above 1 GHz (see 2c and 2e).

c. Configure test equipment as shown in Figure RS103-1.

d. Calibration.

- (1) Placement of electric field sensors (see 3b). Position sensors 1 meter from, and directly opposite, the transmit antenna as shown in Figures RS103-2 and RS103-3. Do not place sensors directly at corners or edges of EUT components.
- (2) Placement of receive antennas (see 3b). Prior to placement of the EUT, position the receive antenna, as shown in Figure RS103-4, on a dielectric stand at the position and height above the ground plane where the center of the EUT will be located.

e. EUT testing.

- (1) Placement of transmit antennas. Antennas shall be placed 1 meter from the test setup boundary as follows:

(a) 10 kHz to 200 MHz

- 1 Test setup boundaries \leq (less than or equal to) 3 meters. Center the antenna between the edges of the test setup boundary. The boundary includes all enclosures of the EUT and the 2 meters of exposed interconnecting and power leads required by the general section of this standard. Interconnecting leads shorter than 2 meters are acceptable when they represent the actual platform installation.
- 2 Test setup boundaries $>$ (greater than) 3 meters. Use multiple antenna positions (N) at spacings as shown in Figure RS103-3. The number of antenna positions (N) shall be determined by dividing the edge-to-edge boundary distance (in meters) by 3 and rounding up to an integer.

- (b) 200 MHz and above. Multiple antenna positions may be required as shown in Figure RS103-2. Determine the number of antenna positions (N) as follows:

- 1 For testing from 200 MHz up to 1 GHz, place the antenna in a sufficient number of positions such that the entire width of each EUT enclosure and the first 35 cm of cables and leads interfacing with the EUT enclosure are within the 3 dB beamwidth of the antenna.
- 2 For testing at 1 GHz and above, place the antenna in a sufficient number of positions such that the entire width of each EUT enclosure and the first 7 cm of cables and leads interfacing with the EUT enclosure are within the 3 dB beamwidth of the antenna.

(2) Maintain the placement of electric field sensors as specified in 3e(1) above.

4. Test Procedures. The test procedures shall be as follows:

- a. Turn on the measurement equipment and EUT and allow a sufficient time for stabilization.
- b. Assess the test area for potential RF hazards and take necessary precautionary steps to assure safety of test personnel.
- c. Calibration.

(1) Electric field sensor method. Record the amplitude shown on the electric field sensor display unit due to EUT ambient. Reposition the sensor, as necessary, until this level is $< 10\%$ of the applicable field strength to be used for testing.

(2) Receive antenna method (> 1 GHz).

- (a) Connect a signal generator to the coaxial cable at the receive antenna connection point (antenna removed). Set the signal source to an output level of 0 dBm at the highest frequency to be used in the present test setup. Tune the measurement receiver to the frequency of the signal source.
- (b) Verify that the output indication is within ± 3 dB of the applied signal, considering all appropriate losses. If larger deviations are

found, locate the source of the error and correct the deficiency before proceeding.

- (c) Connect the receive antenna to the coaxial cable as shown in Figure RS103-4. Set the signal source to 1 kHz pulse modulation, 50% duty cycle. Using an appropriate transmit antenna and amplifier, establish an electric field at the test start frequency. Gradually increase the electric field level until it reaches the applicable limit.
- (d) Scan the test frequency range and record the required input power levels to the transmit antenna to maintain the required field.
- (e) Repeat procedures (a) through (d) whenever the test setup is modified or an antenna is changed.

d. EUT Testing.

(1) E-Field sensor method.

- (a) Set the signal source to 1 kHz pulse modulation, 50% duty cycle, and using appropriate amplifier and transmit antenna, establish an electric field at the test start frequency. Gradually increase the electric field level until it reaches the applicable limit shown in MIL-STD-461.
- (b) Scan the required frequency ranges in accordance with the rates and durations specified in the general section of this standard. Maintain field strength levels in accordance with the applicable limit. Monitor EUT performance for susceptibility effects.

(2) Receive antenna method.

- (a) Remove the receive antenna and reposition the EUT in conformance with 3a.
- (b) Set the signal source to 1 kHz pulse modulation, 50% duty cycle. Using an appropriate amplifier and transmit antenna, establish an electric field at the test start frequency. Gradually increase the input power level until it corresponds to the

applicable level recorded during the calibration routine.

(c) Scan the required frequency range in accordance with the rates and durations specified in the general section of this standard while assuring the correct transmitter input power is adjusted in accordance with the calibration data collected. Constantly monitor the EUT for susceptibility conditions.

(3) If susceptibility is noted, determine the level at which the undesirable response is no longer present and verify it is above the MIL-STD-461 requirement.

(4) Perform testing over the required frequency range with the transmit antenna vertically polarized. Repeat the testing above 30 MHz with the transmit antenna horizontally polarized.

(5) Repeat 4d for each transmit antenna position required by 3e.

5. Data Presentation. Data presentation shall be as follows:

- a. Provide graphical or tabular data showing frequency ranges and field strength levels tested.
- b. Provide graphical or tabular data listing (antenna method only) all calibration data collected to include input power requirements used versus frequency, and results of system check in 4c(2)(c) and 4c(2)(d).
- c. Provide the correction factors necessary to adjust sensor output readings for equivalent peak detection of modulated waveforms.
- d. Provide graphs or tables listing any susceptibility thresholds which were determined along with their associated frequencies.
- e. Provide diagrams or photographs showing actual equipment setup and the associated dimensions.

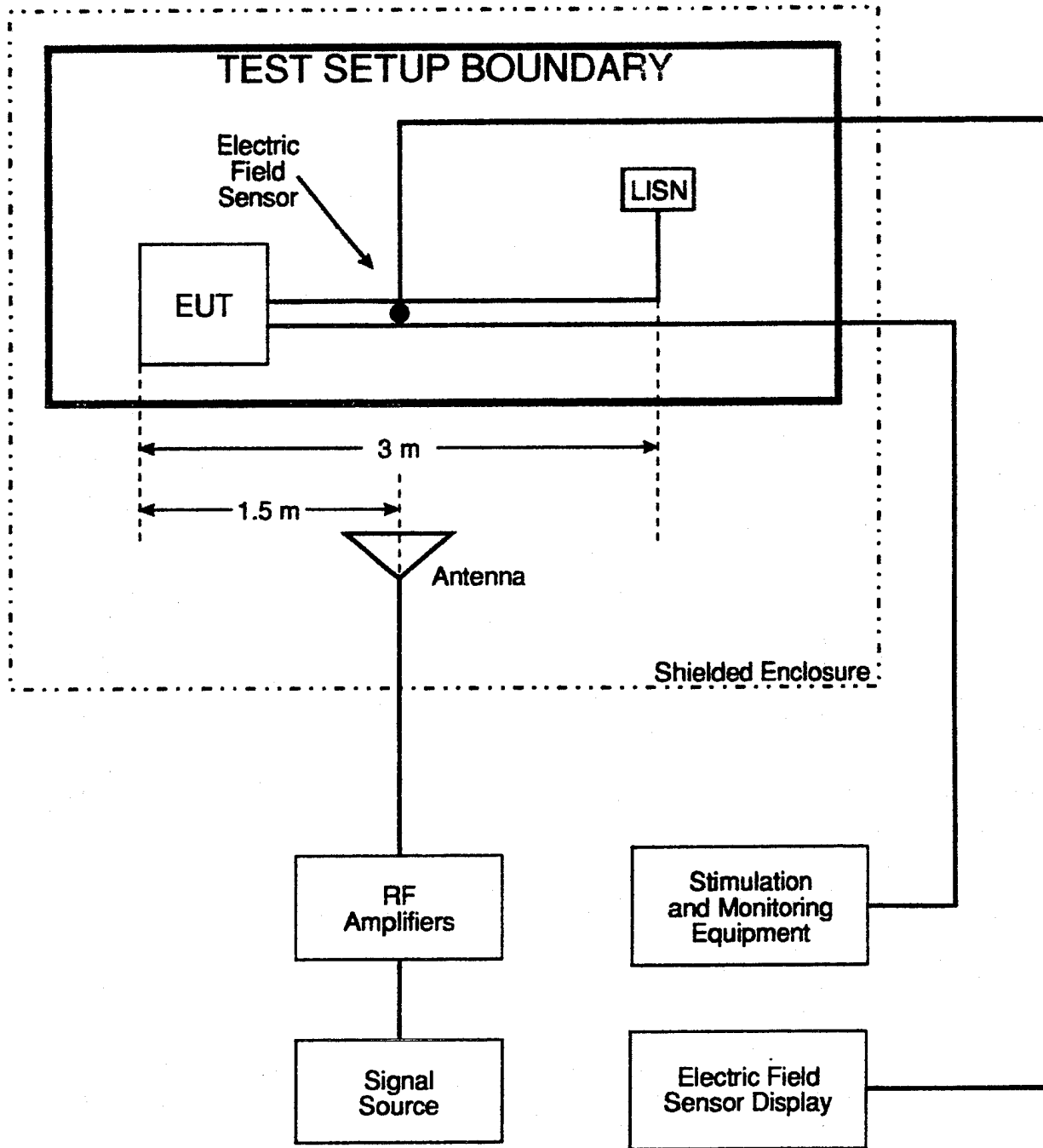

FIGURE RS103-1. Test equipment configuration.

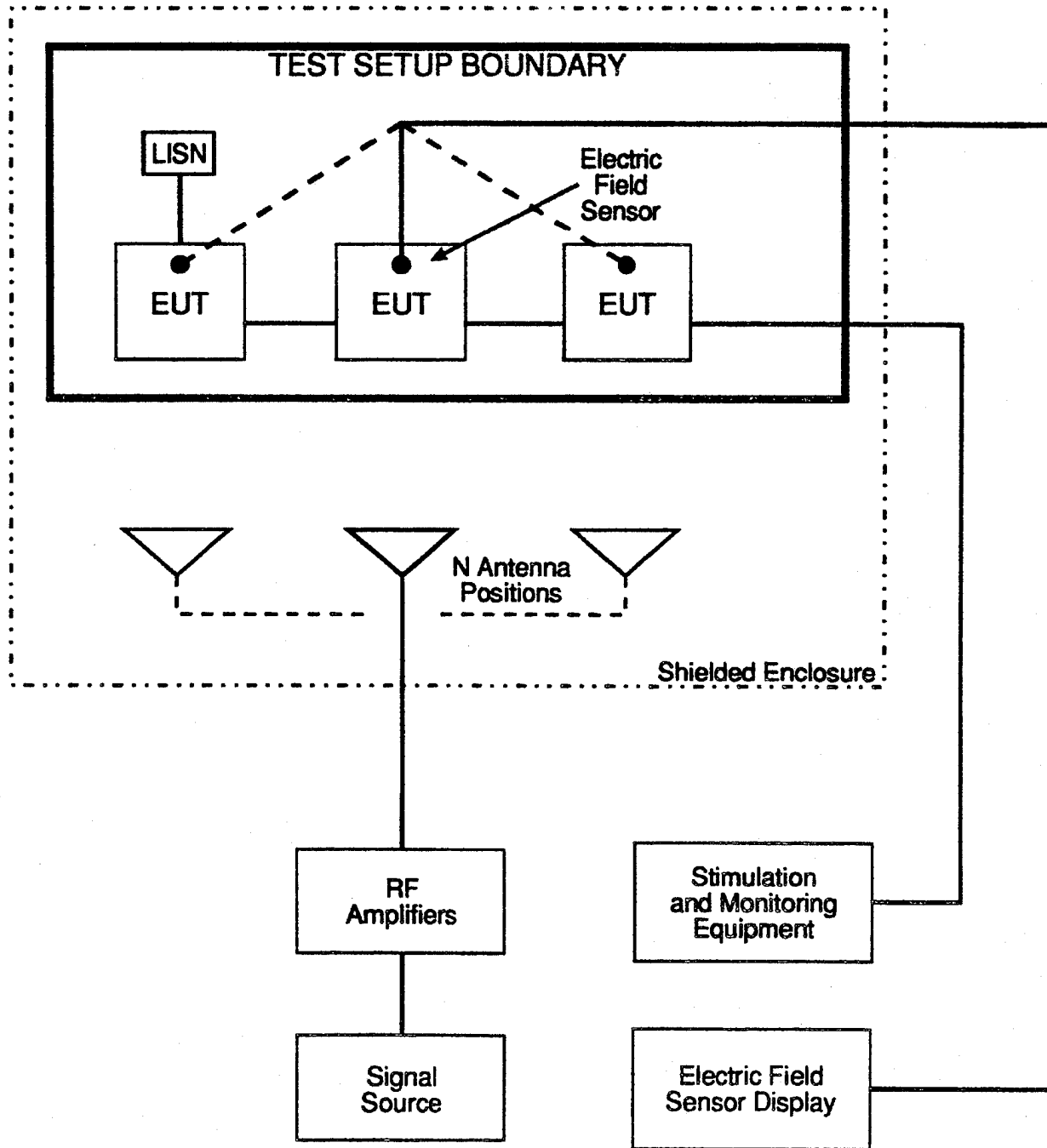

FIGURE RS103-2. Multiple test antenna locations for frequency > 200 MHz.

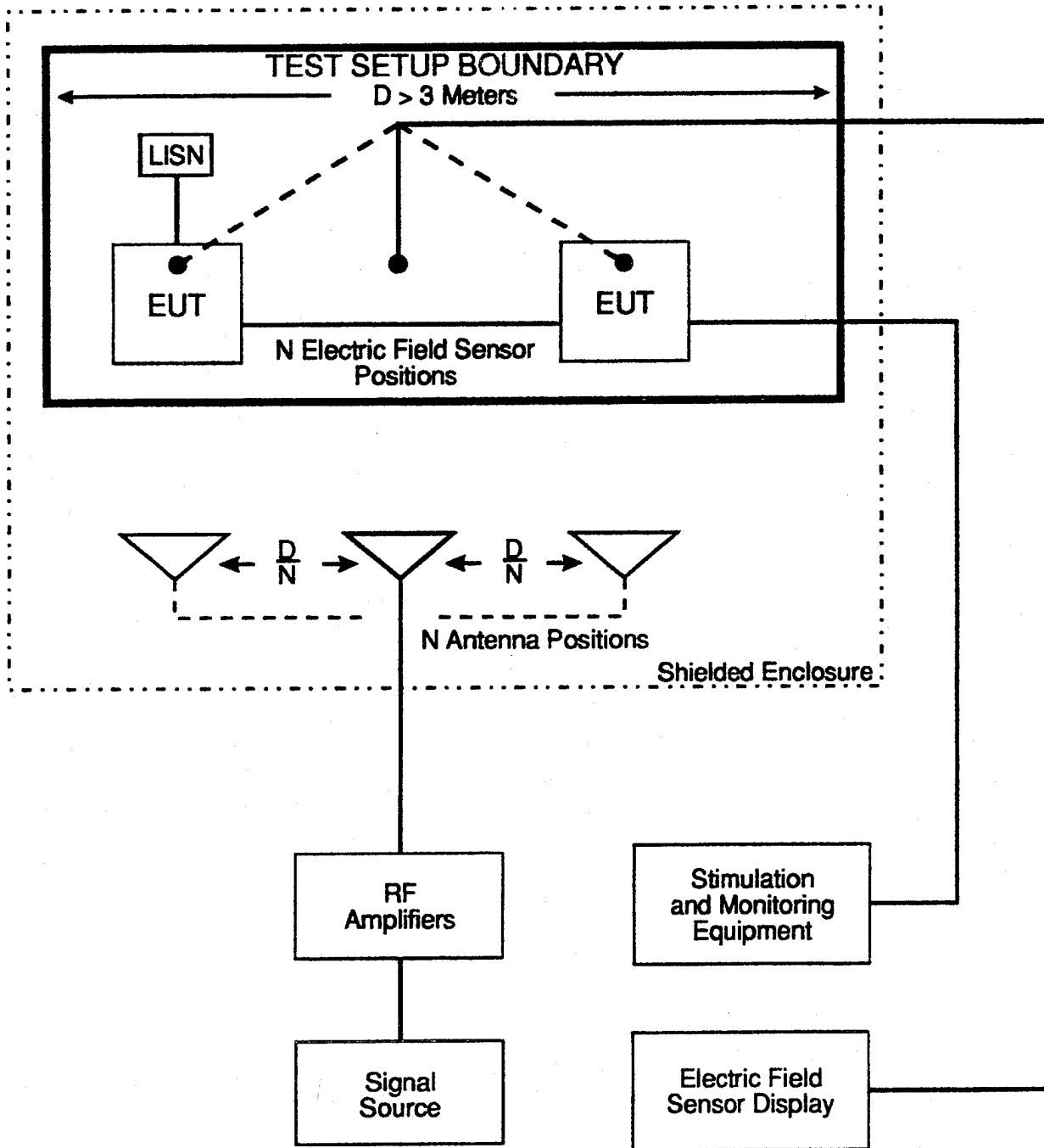

FIGURE RS103-3. Multiple test antenna locations for N positions, $D > 3$ meters.

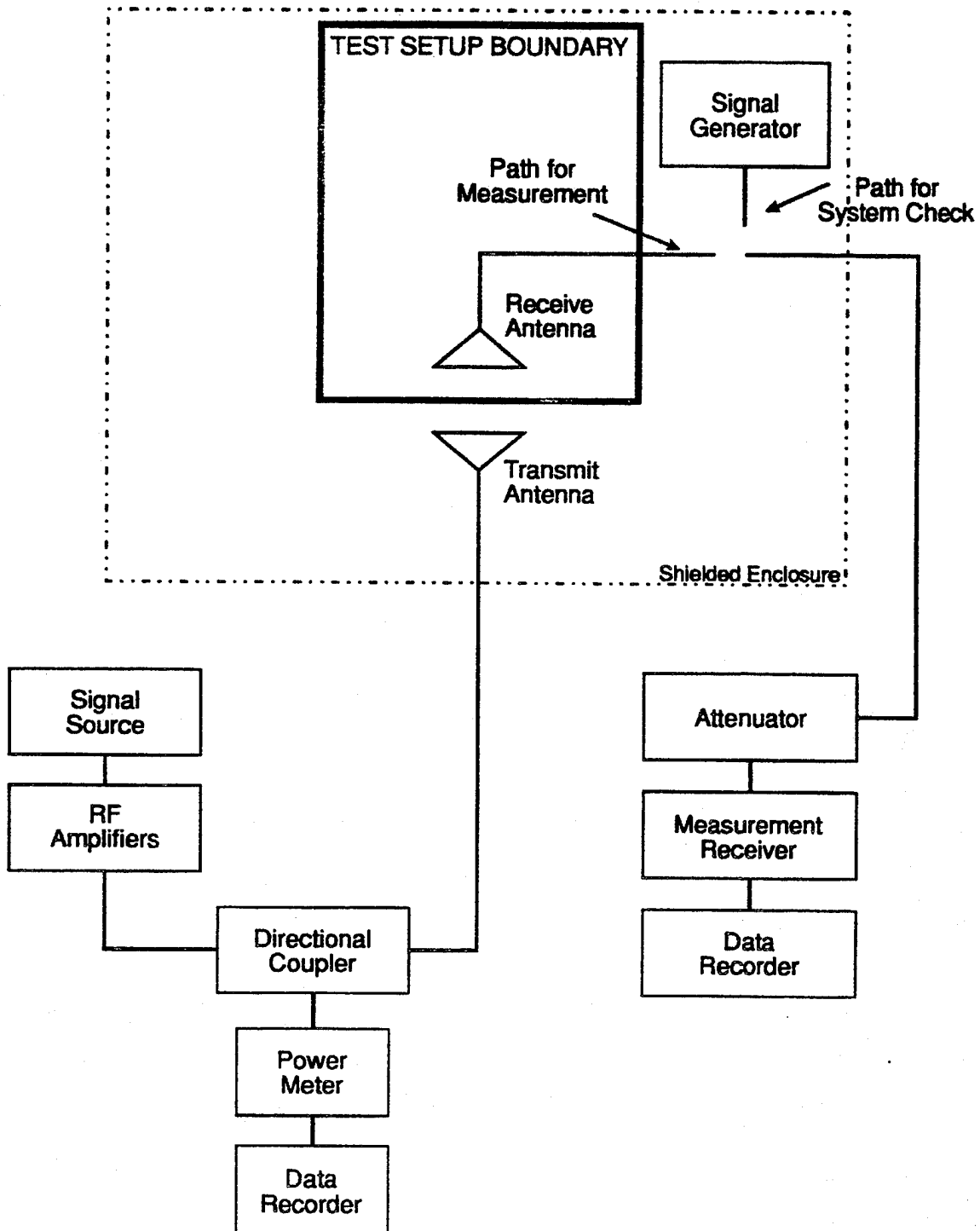

FIGURE RS103-4. Receive antenna method (1 to 40 GHz).

METHOD RS105

RADIATED SUSCEPTIBILITY, TRANSIENT ELECTROMAGNETIC FIELD

1. Purpose. This test method is used to verify the ability of the EUT enclosure to withstand a transient electromagnetic field.
2. Test Equipment. The test equipment shall be as follows:
 - a. Parallel plates, Transverse Electromagnetic (TEM) cell or equivalent
 - b. Transient monopulse generator
 - c. Storage oscilloscope, 200 MHz minimum single shot bandwidth and a variable sampling rate up to 1 gigasample per second (GSa/s)
 - d. Terminal Protection Devices (TPDs)
 - e. High-voltage probe
 - f. B-Dot sensor and integrator
 - g. D-Dot sensor and integrator
 - h. LISNs
3. Test Setup. Maintain the basic test setup for the EUT as described below. CAUTION: Exercise extreme care if an open radiator is used for this test.
 - a. Calibration. Configure the test equipment in accordance with Figure RS105-1.
 - (1) Place the B-Dot or D-Dot probe with integrator in the middle of the empty radiation system. Connect the probe to a storage oscilloscope.
 - (2) Place the high voltage probe across the radiation system termination load. Connect the probe to a storage oscilloscope.
 - b. EUT Testing. Configure the test equipment as shown in Figure RS105-2 for testing of the EUT.

- (1) Place the EUT enclosure on the bottom plate or ground plane of the radiation system in a manner such that it does not exceed the usable volume of the radiation system as shown in Figure RS105-2. The separation between radiating surfaces shall be at least three times the height of the EUT.
- (2) Bond the bottom plate of the radiation system to an earth reference.
- (3) Keep the top plate of the radiation system at least 2 times h from the closest metallic ground, where h is the maximum vertical separation of the plates, including ceiling, building structural beams, metallic air ducts, shielded room walls, and so forth.
- (4) Place the test instrumentation in a shielded enclosure when an open radiator is used.
- (5) Use shielding to protect the cables.
- (6) Place TPDs in the EUT power lines near the power source to protect the power source.
- (7) Connect the monopulse transient generator to the radiation system.

4. Test Procedures. The test procedures shall be as follows:

- a. Turn on the measurement equipment and allow a sufficient time for stabilization.
- b. Calibration. Perform the following procedures using the calibration setup.
 - (1) Generate a single pulse. CAUTION: High voltages are used which are potentially lethal.
 - (2) Observe the pulse to assure that rise time, peak amplitude and decay criteria as specified are met.
- c. EUT Testing. Test the EUT in its orthogonal orientations whenever possible.
 - (1) Turn on the EUT and allow a sufficient time for stabilization.

- (2) Apply the pulse starting at 50% of the required peak level with the specified waveshape. Increase the pulse amplitude slowly until the required level is reached.
- (3) Apply the required number of pulses at a rate of not more than 1 pulse per minute.
- (4) Monitor the applied pulse using at least one of the calibration probes and storage oscilloscope.
- (5) Monitor the EUT during and after the application of each pulse for signs of susceptibility or degradation of performance.
- (6) If an EUT malfunction occurs at a level less than the specified peak level, terminate the test and record the level.
- (7) If susceptibility is noted, determine the level at which the undesirable response is no longer present and verify that it is above the MIL-STD-461 requirement.

5. Data Presentation. Data presentation shall be as follows:

- a. Provide photographs of EUT orientation including cables.
- b. Provide detailed written description of the EUT configuration.
- c. Provide representative oscilloscope photographs of transient waveshape, including peak value, rise and decay times linearly recorded for each applied test transient. Analog time domain X-Y recordings taken from an analog or digitizing oscilloscope are also acceptable.
- d. Provide the pulse number, with the first pulse being Number 1, for each recorded waveshape.
- e. Record the time-to-recovery for each EUT failure, if applicable.

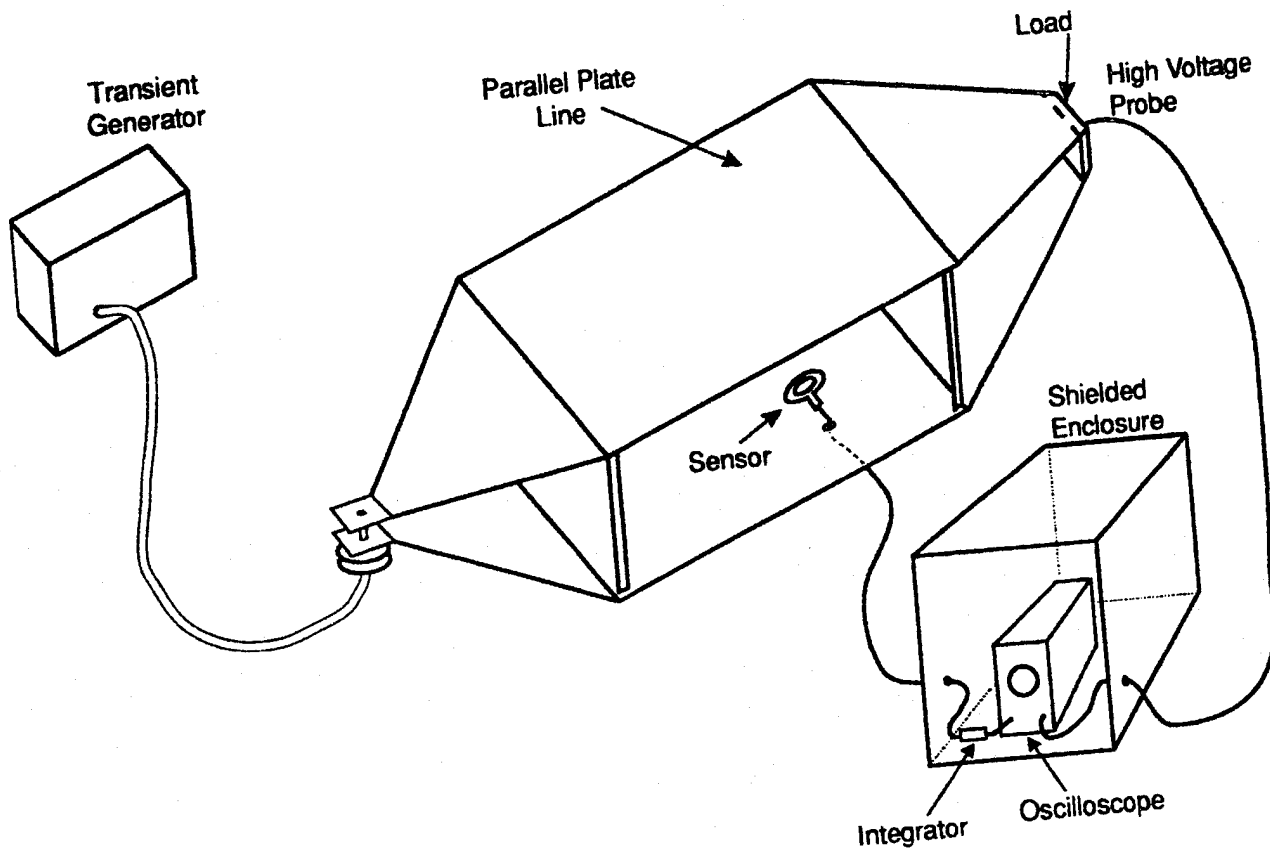

FIGURE RS105-1. Typical calibration setup using parallel plate radiation system.

TOP VIEW

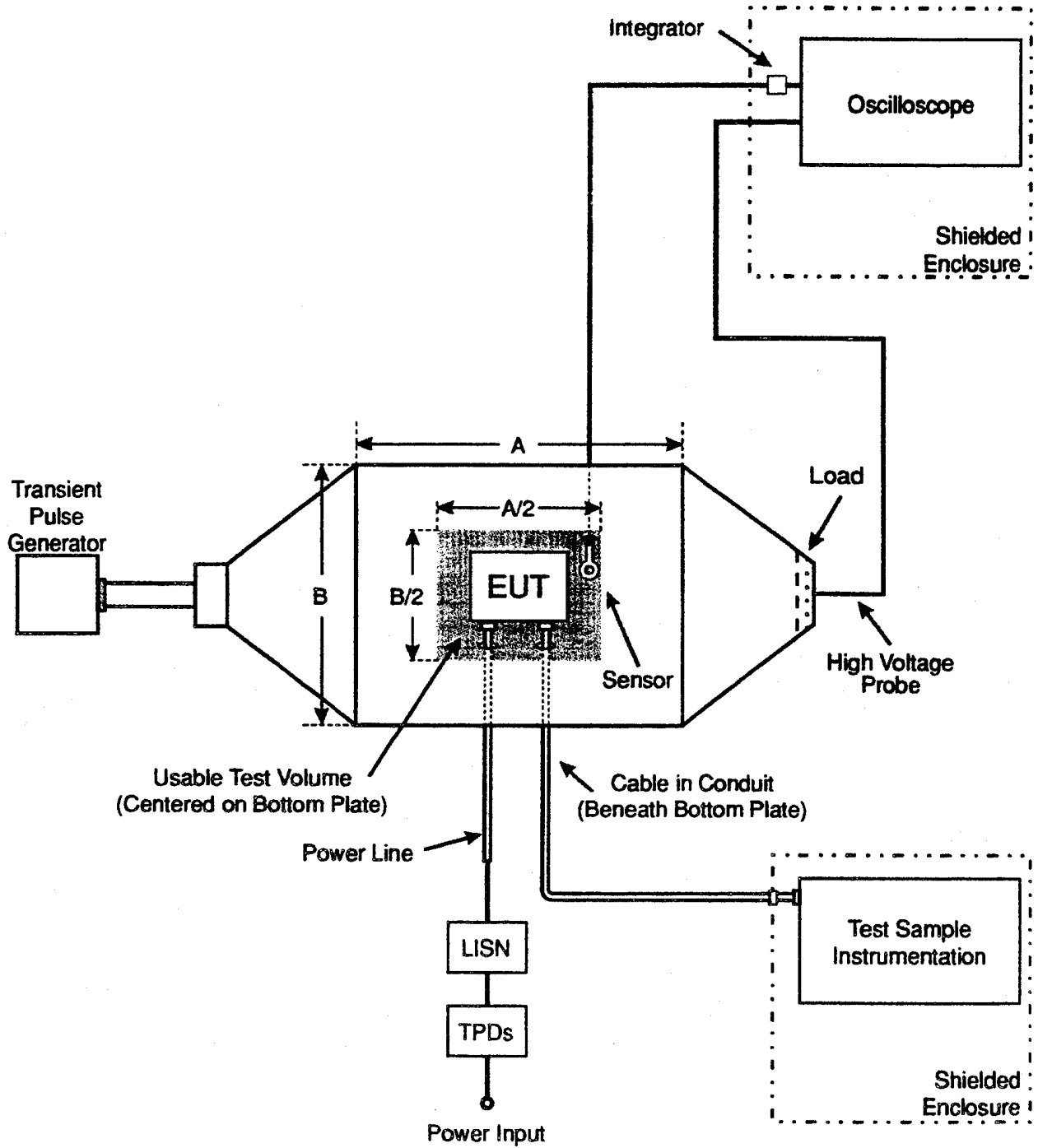

FIGURE RS105-2. Typical test setup using parallel plate radiation system.

CONCLUDING MATERIAL

Custodians:

Army - CR
Navy - EC

Preparing Activity:
Air Force - 11
(Project EMCS-0134)

Review Activities:

Army - MI, AV, TE
Navy - SH, AS, OS, YD, MC, CG, TD
Air Force - 13, 15, 17, 19, 99
NSA

User Activities:

Air Force - 84
Army - AT, ME, CE, CL, MD
DISA
DODECAC
DNA

APPENDIX

MIL-STD-462D
APPLICATION GUIDE

MIL-STD-462D

APPENDIX

CONTENTS

<u>PARAGRAPH</u>		<u>PAGE</u>
10.	GENERAL	A-5
10.1	Scope	A-5
10.2	Structure	A-5
20.	APPLICABLE DOCUMENTS	A-6
20.1	Government documents	A-6
20.1.1	Specifications, standards, and handbooks	A-6
20.1.2	Other Government documents, drawings, and publications	A-6
20.2.	Non-Government publications	A-7
30.	DEFINITIONS	A-9
30.1	General	A-9
30.2	Acronyms used in this appendix	A-9
30.3	Metric units	A-9
30.4	Test setup boundary	A-9
40.	REQUIREMENTS	A-10
40.1	(4.1) General	A-10
40.1.1	(4.1.1) Measurement tolerances	A-10
40.2	(4.2) Shielded enclosures	A-10
40.2.1	(4.2.1) Radio Frequency (RF) absorber material	A-11
40.3	(4.3) Other test sites	A-12
40.4	(4.4) Ambient electromagnetic level	A-12
40.5	(4.5) Ground plane	A-14
40.5.1	(4.5.1) Metallic ground plane	A-14
40.5.2	(4.5.2) Composite ground plane	A-15
40.6	(4.6) Power source impedance	A-15
40.7	(4.7) General test precautions	A-17
40.7.1	(4.7.1) Accessory equipment	A-18
40.7.2	(4.7.2) Excess personnel and equipment	A-18
40.7.3	(4.7.3) Overload precautions	A-19
40.7.4	(4.7.4) RF hazards	A-20
40.7.5	(4.7.5) Shock hazard	A-20
40.7.6	(4.7.6) Federal Communication Commission (FCC) restrictions	A-20
40.8	(4.8) EUT test configurations	A-21
40.8.1	(4.8.1) Bonding of EUT	A-21
40.8.2	(4.8.2) Shock and vibration isolators	A-21
40.8.3	(4.8.3) Wire grounds	A-22
40.8.4	(4.8.4) Orientation of EUTs	A-22
40.8.5	(4.8.5) Construction and arrangement of EUT cables	A-23
40.8.5.1	(4.8.5.1) Interconnecting leads and cables	A-24
40.8.5.2	(4.8.5.2) Input power leads	A-25
40.8.6	(4.8.6) Electrical and mechanical interfaces	A-26

CONTENTS

<u>PARAGRAPH</u>		<u>PAGE</u>
40.9	(4.9) Operation of EUT	A-27
40.9.1	(4.9.1) Operating frequencies for tunable RF equipment	A-27
40.9.2	(4.9.2) Operating frequencies for spread spectrum equipment	A-28
40.9.3	(4.9.3) Susceptibility monitoring	A-28
40.10	(4.10) Use of measuring equipment	A-29
40.10.1	(4.10.1) Detector	A-30
40.10.2	(4.10.2) Computer-controlled receivers	A-32
40.10.3	(4.10.3) Emission testing	A-32
40.10.3.1	(4.10.3.1) Bandwidths	A-32
40.10.3.2	(4.10.3.2) Emission identification	A-33
40.10.3.3	(4.10.3.3) Frequency scanning	A-34
40.10.3.4	(4.10.3.4) Emission data presentation	A-35
40.10.4	(4.10.4) Susceptibility testing	A-37
40.10.4.1	(4.10.4.1) Frequency scanning	A-37
40.10.4.2	(4.10.4.2.) Modulation of susceptibility signals	A-41
40.10.4.3	(4.10.4.3) Thresholds of susceptibility	A-42
40.11	(4.11) Calibration of measuring equipment and antennas	A-42
40.11.1	(4.11.1) Measurement system test	A-43
40.12	(4.12) Antenna factors	A-43
50.0	MEASUREMENT PROCEDURES	A-44
TEST METHOD	CE101	A-44
TEST METHOD	CE102	A-44
TEST METHOD	CE106	A-46
TEST METHOD	CS101	A-47
TEST METHOD	CS103	A-49
TEST METHOD	CS104	A-51
TEST METHOD	CS105	A-54
TEST METHOD	CS109	A-56
TEST METHOD	CS114	A-56
TEST METHOD	CS115	A-60
TEST METHOD	CS116	A-62
TEST METHOD	RE101	A-63
TEST METHOD	RE102	A-64
TEST METHOD	RE103	A-66
TEST METHOD	RS101	A-67
TEST METHOD	RS103	A-68
TEST METHOD	RS105	A-71

MIL-STD-462D
APPENDIX

<u>TABLE</u>		<u>PAGE</u>
I	Absorption at Normal Incidence	A-12
II	Bandwidth and Measurement Time	A-33
III	Susceptibility Scanning	A-38
A-I	Susceptibility Testing Times	A-40

<u>FIGURE</u>		
A-1	Peak detector response	A-31
A-2	Example of data presentation resolution	A-37
A-3	Correction factor for LISN capacitor	A-45
A-4	CS101 Power amplifier protection	A-48
A-5	CS103 General test setup	A-50
A-6	CS104 General test setup	A-53
A-7	CS105 General test setup	A-55
A-8	Typical CS114 calibration fixture	A-58
A-9	Typical insertion loss of CS114 injection probes	A-59
A-10	Circuit diagram of CS115 pulse generator	A-60
A-11	Typical CS115 calibration fixture waveform	A-61

MIL-STD-462D
APPENDIX

10. GENERAL

10.1 Scope. This appendix provides background information for each requirement in the main body of the standard. The information includes rationale for the test requirements and guidance for application of the requirements. This information should help users understand the intent behind the test requirements and adapt them in the Electromagnetic Interference Test Procedures (EMITP) as necessary for particular applications. This appendix is provided for guidance purposes and, as such, should not be interpreted as providing contractual requirements.

10.2 Structure. This appendix follows the same general format as the main body of the standard. A "DISCUSSION" paragraph is provided for each requirement contained in the standard.

20. APPLICABLE DOCUMENTS

20.1 Government documents.

20.1.1 Specifications, standards, and handbooks. The following specifications, standards, and handbooks form a part of this document to the extent specified herein. Unless otherwise specified, the issues of these documents are those listed in the issue of the Department of Defense Index of Specifications and Standards (DODISS) and supplement thereto, cited in the solicitation.

STANDARDS

MILITARY

- MIL-STD-220 - Method of Insertion Loss Measurement
- MIL-STD-285 - Attenuation Measurements for Enclosures, Electromagnetic Shielding, for Electronic Test Purposes, Method of
- MIL-STD-461 - Requirements for the Control of Electromagnetic Interference Emissions and Susceptibility
- MIL-STD-45662 - Calibration Systems Requirements

(Copies of federal and military specifications, standards, and handbooks are available from the Director, Navy Publications and Printing Service Office, 700 Robbins Avenue, Philadelphia, PA 19111-5093.)

20.1.2 Other Government documents, drawings, and publications. The following other Government documents, drawings, and publications form a part of this document to the extent specified herein. Unless otherwise specified, the issues are those cited in the solicitation.

- DODISS - Department of Defense Index of Specifications and Standards

(Copies of the DODISS are available on a yearly subscription basis either from the Government Printing Office for hard copy, or microfiche copies are available from the Director, Navy Publications and Printing Service Office, 700 Robbins Avenue, Philadelphia, PA 19111-5093.)

MIL-STD-462D
APPENDIX

20.2. Non-Government publications. The following documents form a part of this document to the extent specified herein. Unless otherwise specified, the issues of the documents which are DOD adopted are those listed in the issue of the DoDISS cited in the solicitation. Unless otherwise specified, the issues of documents not listed in the DoDISS are the issues of the documents cited in the solicitation.

AMERICAN SOCIETY FOR TESTING AND MATERIALS (ASTM)

ASTM E 380 - Standard for Metric Practice.
(DOD adopted)

(Application for copies should be addressed to the American Society for Testing and Materials, 1916 Race Street, Philadelphia, PA 19103-1187.)

AMERICAN NATIONAL STANDARDS INSTITUTE (ANSI)

ANSI/IEEE 268 - Metric Practice. (DOD adopted)

ANSI C63.2 - Standard for Instrumentation -
Electromagnetic Noise and Field
Strength, 10 kHz to 40 GHz -
Specifications

ANSI C63.4 - Standard for Electromagnetic
Compatibility - Radio-Noise
Emissions from Low Voltage
Electrical and Electronic
Equipment in the Range of 9 kHz
to 1 GHz - Methods of Measurement

ANSI C63.14 - Standard Dictionary for
Technologies of Electromagnetic
Compatibility (EMC),
Electromagnetic Pulse (EMP), and
Electrostatic Discharge (ESD)

ANSI C95.1 - Standard for Safety Levels with
Respect to Human Exposure to
Radio Frequency Electromagnetic
Fields (300 kHz to 100 GHz)

(Application for copies should be addressed to the IEEE Service Center, 445 Hoes Lane, P.O. Box 1331, Piscataway, NJ 08855-1331.)

NATIONAL FIRE PROTECTION ASSOCIATION (NFPA)

National Electrical Code

MIL-STD-462D
APPENDIX

(Application for copies of should be addressed to the National Fire Protection Association, Batterymarch Park, Quincy, MA 02269-9990.)

RADIO TECHNICAL COMMISSION FOR AERONAUTICS

- DO-160 - Environmental Conditions and Test Conditions for Airborne Equipment

(Application for copies should be addressed to Radio Technical Commission for Aeronautics Secretariat, One McPherson Square, Suite 500, 1425 K Street, NW, Washington DC 20005.)

SOCIETY OF AUTOMOTIVE ENGINEERS (SAE)

- ARP 958 - Electromagnetic Interference Measurement Antennas; Standard Calibration Requirements and Methods

- ARP 1972 - Recommended Measurement Practices and Procedures for EMC Testing

(Application for copies should be addressed to the Society of Automotive Engineers, Inc., 400 Commonwealth Drive, Warrendale, PA 15096.)

MIL-STD-462D
APPENDIX

30. DEFINITIONS

30.1 General. The terms used in this appendix are defined in ANSI C63.14. In addition, the following definitions are applicable for the purposes of this appendix.

30.2 Acronyms used in this appendix.

- a. BIT - Built-in-Test
- b. CW - Continuous Wave
- c. EMI - Electromagnetic Interference
- d. EMITP - Electromagnetic Interference Test Procedures
- e. EMITR - Electromagnetic Interference Test Report
- f. EMP - Electromagnetic Pulse
- g. ERP - Effective Radiated Power
- h. EUT - Equipment Under Test
- i. GPI - Ground Plane Interference
- j. LISN - Line Impedance Stabilization Network
- k. RF - Radio Frequency
- l. RMS - Root Mean Square
- m. TEM - Transverse Electromagnetic
- n. VSWR - Voltage Standing Wave Ratio

30.3 Metric units. Metric units are a system of basic measures which are defined by the International System of Units based on "Le System International d'Unites (SI)", of the International Bureau of Weights and Measures. These units are described in ASTM E 380 and ANSI/IEEE 268.

30.4 Test setup boundary. The test setup boundary includes all enclosures of the Equipment Under Test (EUT) and the 2 meters of exposed interconnecting leads (except for leads which are shorter in the actual installation) and power leads required by the general section of this standard.

40. REQUIREMENTS

40.1 (4.1) General. General requirements related to test methods, test facilities, and equipment are as stated below. Any approved exceptions or deviations from these general test requirements shall be documented in the EMITP required by MIL-STD-461.

DISCUSSION: This portion of the document specifies requirements that are applicable to a variety of test methods. Individual test methods include requirements which are unique to that test method only. Other sources of information dealing with electromagnetic interference testing are available in industry documents such as RTCA DO-160 and SAE ARP 1972.

40.1.1 (4.1.1) Measurement tolerances. Unless otherwise stated for a particular measurement, the tolerance shall be as follows:

- a. Distance: $\pm 5\%$
- b. Frequency: $\pm 2\%$
- c. Amplitude, measurement receiver: ± 2 dB
- d. Amplitude, measurement system (includes measurement receivers, transducers, cables, and so forth): ± 3 dB
- e. Time (waveforms): $\pm 5\%$

DISCUSSION: Tolerances are necessary to maintain reasonable controls for obtaining consistent measurements. Paragraphs 4.1.4.b through 4.1.4.d are in agreement with ANSI C63.2 for electromagnetic noise instrumentation.

40.2 (4.2) Shielded enclosures. To prevent interaction between the Equipment Under Test (EUT) and the outside environment, shielded enclosures will usually be required for testing. These enclosures prevent external environment signals from contaminating emission measurements and susceptibility test signals from interfering with electrical and electronic items in the vicinity of the test facility. Shielded enclosures must have adequate attenuation such that the ambient requirements of paragraph 4.4 are satisfied. The enclosures must be sufficiently large such that the EUT arrangement requirements of paragraph 4.8 and antenna positioning requirements described in the individual test methods are satisfied.

MIL-STD-462D
APPENDIX

DISCUSSION: Potential accuracy problems introduced by shielded enclosure resonances are well documented and recognized; however, shielded enclosures are usually a necessity for testing of military equipment to MIL-STD-461 requirements. Most test agencies are at locations where ambient levels outside of the enclosures are significantly above MIL-STD-461 limits and would interfere with the ability to obtain meaningful data.

Electrical interfaces with military equipment are often complex and require sophisticated test equipment to simulate and evaluate the interface. This equipment usually must be located outside of the shielded enclosure to achieve sufficient isolation and prevent it from contaminating the ambient and responding to susceptibility signals.

The shielded enclosure also prevents radiation of applied susceptibility signals from interfering with local antenna-connected receivers. The most obvious potential offender is the RS103 test. However, other susceptibility tests can result in substantial radiated energy which may violate Federal Communication Commission (FCC) rules. Shielded enclosures with the following characteristics will typically provide the required isolation:

- a. Shielding effectiveness of 80 decibels (dB) with respect to electric fields and plane waves above 10 kHz as measured in accordance with MIL-STD-285.
- b. Powerline filtering of 80 dB attenuation at frequencies above 10 kHz as measured in accordance with MIL-STD-220.

40.2.1 (4.2.1) Radio Frequency (RF) absorber material. RF absorber material (carbon impregnated foam pyramids, ferrite tiles, and so forth) shall be used when performing electric field radiated emission or radiated susceptibility testing inside a shielded enclosure to reduce reflections of electromagnetic energy and to improve accuracy and repeatability. The RF absorber shall be placed above, behind, and on both sides of the EUT, and behind the radiating or receiving antenna as shown in Figure 1. Minimum performance of the material shall be as specified in Table I. The manufacturer's certification of their RF absorber material (basic material only, not installed) is acceptable.

DISCUSSION: Accuracy problems with making measurements in untreated shielded enclosures due to reflections of electromagnetic energy have been widely recognized and documented. The values of RF absorption required by Table I are considered to be sufficient to substantially improve the integrity of the measurements without unduly impacting test

MIL-STD-462D
APPENDIX

facilities. The minimum placement provisions for the material are specified to handle the predominant reflections. The use of additional material is desirable, where possible. It is intended that the values in Table I can be met with available ferrite tile material or standard 24 inch (0.61 meters) pyramidal absorber material.

TABLE I. Absorption at Normal Incidence.

Frequency	Minimum Absorption
80 MHz - 250 MHz	6 dB
above 250 MHz	10 dB

40.3 (4.3) Other test sites. If other test sites are used, the ambient requirements of paragraph 4.4 shall be met.

DISCUSSION: For certain types of EUTs, testing in a shielded enclosure may not be practical. Examples are EUTs which are extremely large, require high electrical power levels or motor drives to function, emit toxic fumes, contain explosives such as squibs, or are too heavy for normal floor loading. There is a serious concern with ambient levels contaminating data when testing is performed outside of a shielded enclosure. Therefore, special attention is given to this testing under paragraph 4.4, "Ambient electromagnetic level." All cases where testing is performed outside a shielded enclosure shall be justified in detail in the EMITP including typical profiles of expected ambient levels.

An option in emission testing is the use of an open area test site (OATS) in accordance with ANSI C63.4. These sites are specifically designed to enhance accuracy and repeatability. Due to differences between ANSI C63.4 and this standard in areas such as antenna selection, measurement distances, and specified frequency ranges, the EMITP shall detail the techniques for using the OATS and relating the test results to MIL-STD-461 requirements.

40.4 (4.4) Ambient electromagnetic level. During testing, the ambient electromagnetic level measured with the EUT de-energized and all auxiliary equipment turned on shall be at least 6 dB below the allowable specified limits when the tests are performed in a shielded enclosure. Ambient conducted levels on power leads shall be measured with the leads disconnected from the EUT and connected to a resistive load which draws the same rated current as the EUT. When tests are performed in a shielded enclosure and the EUT is in compliance with MIL-STD-461 limits, the ambient profile need not be recorded in the Electromagnetic

MIL-STD-462D
APPENDIX

Interference Test Report (EMITR). When measurements are made outside a shielded enclosure, the tests shall be performed during times and conditions when the ambient is at its lowest level. The ambient shall be recorded in the EMITR required by MIL-STD-461 and shall not compromise the test results.

DISCUSSION: Controlling ambient levels is critical to maintaining the integrity of the gathered data. High ambients present difficulties distinguishing between EUT emissions and ambient levels. Even when specific signals are known to be ambient related, they may mask EUT emissions which are above MIL-STD-461 limits.

The requirement that the ambient be at least 6 dB below the limit ensures that the combination of the EUT emissions and ambient does not unduly affect the indicated magnitude of the emission. Since the EUT emissions are not phase coherent with the ambient, the signals combine with the square root of the sum of the squares of the individual voltage amplitudes. If a true emission level is at the limit and the ambient is 6 dB below the limit, the indicated level would be 1.0 dB above the limit. Similarly, if the ambient were allowed to be equal to the limit for the same true emission level, the indicated level would be 3.0 dB above the limit.

A resistive load is specified to be used for conducted ambients on power leads. However, under certain conditions actual ambient levels may be higher than indicated with a resistive load. The most likely reason is the presence of capacitance at the power interface of the EUT which will lower the input impedance at higher frequencies and increase the current. This capacitance should be determined and ambient measurements repeated with the capacitance in place. There is also the possibility of resonance conditions with shielded room filtering, EUT filtering, and powerline inductance. These types of conditions may need to be investigated if unexpected emission levels are observed.

Testing outside of a shielded enclosure often must be performed at night to minimize influences of the ambient. A prevalent problem with the ambient is that it continuously changes with time as various emitters are turned on and off and as amplitudes fluctuate. A useful tool for improving the flow of testing is to thoroughly analyze the EUT circuitry prior to testing and identify frequencies where emissions may be expected to be present.

An option to improve overall measurement accuracy is to make preliminary measurements inside a shielded enclosure and accurately determine frequencies where emissions are present. Testing can be continued outside the shielded enclosure with

measurements being repeated at the selected frequencies. The 6 dB margin between the ambient and limits must then be observed only at the selected frequencies.

40.5 (4.5) Ground plane. The EUT shall be installed on a ground plane that simulates the actual installation. If the actual installation is unknown or multiple installations are expected, then a metallic ground plane shall be used. Unless otherwise specified below, ground planes shall be 2.25 square meters or larger in area with the smaller side no less than 76 centimeters. When a ground plane is not present in the EUT installation, the EUT shall be placed on a non-conductive surface.

DISCUSSION: Generally, the radiated emissions and radiated susceptibilities of equipment are due to coupling from and to the interconnecting cables and not via the case of the EUT. Emissions and susceptibility levels are directly related to the placement of the cable with respect to the ground plane and to the electrical conductivity of the ground plane. Thus, the ground plane plays an important role in obtaining the most realistic test results.

When the EUT is too large to be installed on a conventional ground plane on a bench, the actual installation should be duplicated. For example, a large radar antenna may need to be installed on a test stand and the test stand bonded to the floor of the shielded enclosure. Ground planes need to be placed on the floor of shielded rooms with floor surfaces such as tiles which are not electrically conductive.

The use of ground planes is also applicable for testing outside of a shielded enclosure. These ground planes will need to be referenced to earth as necessary to meet the electrical safety requirements of the National Electrical Code. Where possible, these ground planes should be electrically bonded to other accessible grounded reference surfaces such as the outside structure of a shielded enclosure.

The minimum dimensions for a ground plane of 2.25 square meter with 76 centimeters on the smallest side will be adequate only for setups involving a limited number of EUT enclosures with few electrical interfaces. The ground plane must be large enough to allow for the requirements included in paragraph 4.8 on positioning and arrangement of the EUT and associated cables to be met.

40.5.1 (4.5.1) Metallic ground plane. When the EUT is installed on a metallic ground plane, the ground plane shall have a surface resistance no greater than 0.1 milliohms per square. The DC resistance between metallic ground planes and the shielded

MIL-STD-462D
APPENDIX

enclosure shall be 2.5 milliohms or less. The metallic ground planes shown in Figures 2 through 5 shall be electrically bonded to the floor or wall of the basic shielded room structure at least once every 1 meter. The metallic bond straps shall be solid and maintain a five-to-one ratio or less in length to width. Metallic ground planes used outside a shielded enclosure shall be at least 2 meters by 2 meters and extend at least 0.5 meter beyond the test setup boundary.

DISCUSSION: For the metallic ground plane, a copper ground plane with a thickness of 0.25 millimeters has been commonly used and satisfies the surface resistance requirements. Other metallic materials of the proper size and thickness needed to achieve the resistivity can be substituted.

For metallic ground planes, the surface resistance can be calculated by dividing the bulk resistivity by the thickness. For example, copper has a bulk resistivity of $1.75(10^{-8})$ ohm-meters. For a 0.25 millimeter $2.5(10^{-4})$ meters) thick ground plane as noted above, the surface resistance is $(1.7(10^{-8})) / (2.5(10^{-4})) = (6.8(10^{-5}))$ ohms per square = 0.068 milliohms per square. The requirement is 0.1 milliohms per square.

40.5.2 (4.5.2) Composite ground plane. When the EUT is installed on a conductive composite ground plane, the surface resistivity of the typical installation shall be used. Composite ground planes shall be electrically bonded to the enclosure with means suitable to the material.

DISCUSSION: A copper ground plane has typically been used for all testing in the past. For most instances, this has been adequate. However, with the increasing use of composites, the appropriate ground plane will play a bigger role in the test results. Limited testing on both copper and conductive composite ground planes has shown some differences in electromagnetic coupling test results, thus the need exists to duplicate the actual installation, if possible. In some cases, it may be necessary to include several ground planes in the same test setup if different units of the same EUT are installed on different materials in the installation.

With the numerous different composite materials being used in installations, it is not possible to specify a general resistivity value. The typical resistivity of carbon composite is about 2000 times that of aluminum. The actual resistivity needs to be obtained from the installation contractor and used for testing.

40.6 (4.6) Power source impedance. The impedance of power sources providing input power to the EUT shall be controlled by

MIL-STD-462D
APPENDIX

Line Impedance Stabilization Networks (LISNs) for all measurements procedures of this document unless otherwise stated in a particular test method. The LISNs shall be located at the power source end of the exposed length of power leads specified in paragraph 4.8.5.2. The LISN circuit shall be in accordance with the schematic shown in Figure 6. The LISN impedance characteristics shall be in accordance with Figure 7. The LISN impedance shall be measured under the following conditions:

- a. The impedance shall be measured between the power output lead on the load side of the LISN and the metal enclosure of the LISN.
- b. The signal output port of the LISN shall be terminated in fifty ohms.
- c. The power input terminal on the power source side of the LISN shall be unterminated.

The impedance measurement results shall be provided in the EMITR required by MIL-STD-461

DISCUSSION: The impedance is standardized to represent expected impedances in actual installations and to ensure consistent results between different test agencies. Previous versions of MIL-STD-462 used 10 microfarad feedthrough capacitors on the power leads. The intent of these devices was to determine the current generator portion of a Norton current source model. If the impedance of the interference source were also known, the interference potential of the source could be analytically determined for particular circumstances in the installation. A requirement was never established for measuring the impedance portion of the source model. More importantly, concerns arose over the test configuration influencing the design of powerline filtering. Optimized filters are designed based on knowledge of both source and load impedances. Significantly different filter designs will result for the 10 microfarad capacitor loading versus the impedance loading shown in Figure 7 of the main body.

The particular configuration of the LISN is specified for several reasons. A number of experiments were performed to evaluate typical power line impedances present in a shielded room on various power input types both with and without power line filters and to assess the possible methods of controlling the impedance. An approach was considered for the standard to simply specify an impedance curve from 30 Hz to 100 MHz and to allow the test agency to meet the impedance using whatever means the agency found suitable. The experiments showed that there were no straightforward techniques to maintain desired controls over the entire frequency range.

A specific 50 microhenry LISN was selected to maintain a standardized control on the impedance as low as 10 kHz. Five microhenry LISNs used commonly in the past provide little control below 100 kHz. Impedance control below 10 kHz is difficult. From evaluations of several 50 microhenry LISN configurations, the one specified demonstrated the best overall performance for various shielded room filtering variations. Near 10 kHz, the reactances of the 50 microhenry inductor and 8 microfarad capacitor cancel and the LISN is effectively a 5 ohm resistive load across the power line.

Caution needs to be exercised in using the LISN for 400 Hz power systems. Some existing LISNs may not have components sufficient to handle the power dissipation requirements. At 115 volts, 400 Hz, the 8 microfarad capacitor and 5 ohm resistor will pass approximately 2.3 amperes which results in 26.5 watts being dissipated in the resistor.

40.7 (4.7) General test precautions.

DISCUSSION: The requirements included in paragraph 4.7 cover important areas related to improving test integrity and safety that need special attention. There are many other areas where test difficulties may develop. Some are described here.

It is common for shields to become loose or broken at connectors on coaxial cables resulting in incorrect readings. There also are cases where center conductors of coaxial cables break or separate. Periodic tests should be performed to ensure cable integrity. Special low loss cables may be required when testing at higher frequencies.

Caution needs to be exercised when performing emission testing at frequencies below approximately 10 kHz to avoid ground loops in the instrumentation which may introduce faulty readings. A single-point ground often needs to be maintained. It is usually necessary to use isolation transformers at the measurement receiver and accessory equipment. The single-point ground is normally established at the access (feedthrough) panel for the shielded enclosure. However, if a transducer is being used which requires an electrical bond to the enclosure (such as the rod antenna counterpoise), the coaxial cable will need to be routed through the enclosure access panel without being grounded. Since the shielded room integrity will then be compromised, a normal multiple point grounded setup needs to be re-established as low in frequency as possible.

Rather than routing the coaxial cable through the enclosure access panel without grounding it to the enclosure, a 50-ohm video isolation transformer may be connected to the grounded RF connector at the access panel inside the room. Normal connection

MIL-STD-462D
APPENDIX

of the measuring receiver is made to the grounded connector at the panel outside the room. This technique effectively breaks the ground loop without sacrificing the room's shielding integrity. The losses of the video isolation transformer must be accounted for in the measurement data. These devices are typically useful up to approximately 10 MHz.

If isolation transformers are found to be necessary in certain setups, problems may exist with items powered by switching power supplies. A solution is to use transformers which are rated at approximately five times the current rating of the item.

Solid state instrumentation power sources have been found to be susceptible to radiated fields even to the extent of being shut down. It is best to keep these items outside of the shielded enclosure.

40.7.1 (4.7.1) Accessory equipment. Accessory equipment used in conjunction with measurement receivers shall not degrade measurement integrity.

DISCUSSION: Measurement receivers are generally designed to meet MIL-STD-461 limits so they do not contaminate the ambient for emission testing when they are used inside the shielded enclosure. However, accessory equipment such as computers, oscilloscopes, plotters, or other instruments used to control the receiver or monitor its outputs can cause problems. They may compromise the integrity of the receiver by radiating signals conducted out of the receiver from improperly treated electrical interfaces or may produce interference themselves and raise the ambient. Even passive devices such as headsets have been known to impact the test results.

It is best to locate all of the test equipment outside of the shielded enclosure with the obvious exception of the transducer (antenna or current probe). Proper equipment location will ensure that the emissions being measured are being generated in the EUT only and will help ensure that the ambient requirements of paragraph 4.4 are met. If the equipment must be used inside the enclosure or if testing is being conducted outside of an enclosure, the measurement receiver and accessory equipment should be located as far away from the transducers as practical to minimize any impact.

40.7.2 (4.7.2) Excess personnel and equipment. The test area shall be kept free of unnecessary personnel, equipment, cable racks, and desks. Only the equipment essential to the test being performed shall be in the test area or enclosure. Only personnel actively involved in the test shall be permitted in the enclosure.

MIL-STD-462D
APPENDIX

DISCUSSION: Excess personnel and both electronic and mechanical equipment such as desks or cable racks in the enclosure can affect the test results. During radiated emission testing in particular, all nonessential personnel and equipment need to be removed from the test site. Any object in the enclosure can significantly influence or introduce standing waves in the enclosure and thus alter the test results. The requirement to use RF absorber material will help to mitigate these effects. However, requirements for the material are not defined below 80 MHz for practical reasons and standing waves continue to be a concern.

40.7.3 (4.7.3) Overload precautions. Measurement receivers and transducers are subject to overload, especially receivers without preselectors and active transducers. Periodic checks shall be performed to assure that an overload condition does not exist. Instrumentation changes shall be implemented to correct any overload condition.

DISCUSSION: Overloads can easily go unnoticed if there is not an awareness of the possibility of an overload or active monitoring for the condition. The usual result is a leveling of the output indication of the receiver.

Two types of overloads are possible. A narrowband signal such as a sinusoid can saturate any receiver or active transducer. Typical procedures for selecting attenuation settings for measurement receivers place detected voltages corresponding to MIL-STD-461 emission limits well within the dynamic range of the receiver. Saturation problems for narrowband type signals will normally only appear for a properly configured receiver if emissions are significantly above the limits. Saturation can occur more readily when receivers are used to monitor susceptibility signals due to the larger voltages involved.

Overload from impulsive type signals with broad frequency content can be much more deceptive. This condition is most likely to occur with devices without a tuneable bandpass feature in the first stage of the signal input. Examples are preamplified rod antennas and receivers without preselectors (primarily certain spectrum analyzers). The input circuitry is exposed to energy over a large portion of the frequency spectrum. Preselectors include a tuneable tracking filter which bandwidth limits the energy applied to the receiver front end circuitry.

Measurement receiver overload to both narrowband and impulsive type signals can be evaluated by applying 10 dB additional attenuation in the first stage of the receiver (before mixer circuitry) or external to the receiver. If overload is not present, the observed output will uniformly decrease by 10 dB.

MIL-STD-462D
APPENDIX

Overload conditions for active antennas are normally published as part of the literature supplied with the antenna. For narrowband signals, the indicated level in the data can be reviewed with respect to the literature to evaluate overload. Levels are also published for impulsive type signals; however, these levels are not very useful since they usually assume that a flat field exists across the useable range of the antenna. In reality, the impulsive field will vary significantly with frequency and the antenna circuitry sees the integration of the spectral content of this field over its bandpass. The primary active antenna used is an active rod antenna. Overload can be evaluated by collapsing the rod and observing the change in indication. If overload is not present, the indicated level should drop approximately 8 dB. The actual change for any particular manufacturer's product will depend on the telescoping design and can be determined by radiating a signal to the antenna which is within its linear range.

40.7.4 (4.7.4) RF hazards. Some tests in this standard will result in electromagnetic fields which are potentially dangerous to personnel. The permissible exposure levels in ANSI C95.1 shall not be exceeded in areas where personnel are present. Safety procedures and devices shall be used to prevent accidental exposure of personnel to RF hazards.

DISCUSSION: During some radiated susceptibility and radiated emission testing, RS103, RS105 and RE103 in particular, fields may exceed the permissible exposure levels in ANSI C95.1. During these tests, precautions must be implemented to avoid inadvertent exposure of personnel. Monitoring of the EUT during testing may require special techniques such as remotely connected displays external to the enclosure or closed circuit television to adequately protect personnel.

40.7.5 (4.7.5) Shock hazard. Some of the tests require potentially hazardous voltages to be present. Extreme caution must be taken by all personnel to assure that all safety precautions are observed.

DISCUSSION: A safety plan and training of test personnel are normally required to assure that accidents are minimized. Test equipment manufacturers' precautions need to be followed, if specified. If these are not available, the test laboratory should establish adequate safety precautions and train all test personnel. Special attention should be observed for Method CS109 since electronics enclosures are intentionally isolated from the ground plane for test purposes.

40.7.6 (4.7.6) Federal Communication Commission (FCC) restrictions. Some of the tests require high level signals to be generated that could interfere with normal FCC approved frequency

assignments. All such testing should be conducted in a shielded enclosure. Some open site testing may be feasible if prior FCC coordination is obtained.

DISCUSSION: Radiated susceptibility RS103 testing and possibly other tests will produce signals above FCC authorizations. This situation is one of the reasons that shielded enclosures are usually required for MIL-STD-462 testing. In some rare instances, the FCC may permit levels higher than normal if prior coordination is obtained.

40.8 (4.8) EUT test configurations. The EUT shall be configured as shown in the general test setups of Figures 1 through 5 as applicable. These setups shall be maintained during all testing unless other direction is given for a particular test method.

DISCUSSION: Emphasis is placed on "maintaining" the specified setup for all testing unless a particular test method directs otherwise. Confusion has resulted from previous versions of the standard regarding consistency of setups from test method to test method in areas such as lead lengths and placement of 10 uF capacitors on power leads. In this version of the standard, any changes from the general test setup are specifically stated in the individual test method.

40.8.1 (4.8.1) Bonding of EUT. Only the provisions included in the design of the EUT shall be used to bond units such as equipment case and mounting bases together, or to the ground plane. When bonding straps are required to complete the test setup, they shall be identical to those specified in the installation drawings.

DISCUSSION: Electrical bonding provisions for equipment are an important aspect of platform installation design. Adequacy of bonding is usually one of the first areas reviewed when platform problems develop. Electrical bonding controls common mode voltages that develop between the equipment enclosures and the ground plane. Voltages potentially affecting the equipment will appear across the bonding interface when RF stresses are applied during susceptibility testing. Voltages will also develop due to internal circuit operation and will contribute to radiated emission profiles. Therefore, it is important that the test setup use actual bonding provisions so that test results are representative of the intended installation.

40.8.2 (4.8.2) Shock and vibration isolators. EUTs shall be secured to mounting bases having shock or vibration isolators if such mounting bases are used in the installation. The bonding straps furnished with the mounting base shall be connected to the

MIL-STD-462D
APPENDIX

ground plane. When mounting bases do not have bonding straps, bonding straps shall not be used in the test setup.

DISCUSSION: Including shock and vibration isolators in the setup when they represent the platform installation is important. The discussion above for paragraph 4.8.1 is also applicable to shock and vibration isolators; however, the potential effect on test results is even greater. Hard mounting of the equipment enclosures to the ground plane can produce a low impedance path across the bonding interface over most of the frequency range of interest. The bonding straps associated with isolators will typically represent significant impedances at frequencies as low as tens of kilohertz. The common mode voltages associated with these impedances will generally be greater than the hard mounted situation. Therefore, the influence on test results can be substantial.

40.8.3 (4.8.3) Wire grounds. When external terminals, connector pins, or equipment grounding conductors in power cables are available for ground connections and are used in the actual installation, they shall be connected to the ground plane after a 2 meter exposed length (see 4.8.5). Shorter lengths shall be used if they are specified in the installation instructions.

DISCUSSION: Wire grounds used in equipment enclosures have been the source of problems during EMI testing. Since they are connected to the equipment enclosure, they would be expected to be at a very low potential with respect to the ground plane and a non-contributor to test results. However, the wire lengths within enclosures are often sufficiently long that coupling to them results from noisy circuits. Also, the wire grounds can conduct induced signals from external sources and reradiate within the equipment enclosure. Therefore, they must be treated similarly to other wiring.

40.8.4 (4.8.4) Orientation of EUTs. EUTs shall be oriented such that surfaces which produce maximum radiated emissions and respond most readily to radiated signals face the measurement antennas. Bench mounted EUTs shall be located 10 \pm 2 centimeters from the front edge of the ground plane subject to allowances for providing adequate room for cable arrangement as specified below.

DISCUSSION: Determination of appropriate surfaces is usually straightforward. Seams on enclosures which have metal-to-metal contact or contain EMI gaskets rarely contribute and should be considered low priority items. Prime candidates are displays such as video screens, ventilation openings, and cable penetrations. In some cases, it may be necessary to probe the surfaces with a sensor and measurement receiver to decide on EUT orientation.

MIL-STD-462D
APPENDIX

Previous versions of this standard specifically required probing with a loop antenna to determine localized areas producing maximum emissions or susceptibility for radiated electric field testing. The test antennas were to be placed one meter from the identified areas. The requirement was not included in this version of MIL-STD-462 due to difficulties in applying the requirement and the result that probing was often not performed. Probing implies both scanning in frequency and physical movement of the probe. These two actions cannot be performed in a manner to cover all physical locations at all frequencies. A complete frequency scan can be performed at particular probe locations and movement of the probe over the entire test setup can be performed at particular frequencies. The detailed requirements on the use of multiple antenna positions and specific requirements on the placement of the antennas in test methods RE102 and RS103 minimize concerns with the need to probe.

40.8.5 (4.8.5) Construction and arrangement of EUT cables. Electrical cable assemblies shall simulate actual installation and usage. Shielded cables or shielded leads (including power lead and wire grounds) within cables shall be used only if they have been specified in installation drawings. Cables shall be checked against installation requirements to verify proper construction techniques such as use of twisted pairs, shielding, and shield terminations. Details on the cable construction used for testing shall be included in the EMITP.

DISCUSSION: For most EUTs, electrical interface requirements are covered in interface control or similar documents. Coordination between equipment manufacturers and system integration organizations is necessary to ensure a compatible installation from both functional and electromagnetic interference standpoints. For general purpose EUTs, which may be used in many different installations, either the equipment specifications cover the interface requirements or the manufacturers publish recommendations in the documentation associated with the equipment.

Equipment manufacturers sometimes contend that failures during EMI testing are not due to their equipment and can be cured simply by placing overall shields on the interface cabling. This concept is unacceptable. High level emissions are often caused by electronic circuits within EUT enclosures coupling onto cables simulating the installation which interface with the EUT. Overall shielding of the cabling is certainly permissible if it is present in the installation. However, the use of overall shielding which is not representative of the installation would result in test data which is useless. Also, overall shielding of cabling in some installations is not a feasible option due to weight and maintenance penalties. The presence of platform

structure between cabling and antennas on a platform is not an acceptable reason for using overall shields on cables for testing in accordance with this standard. The presence of some platform shielding is a basic assumption.

There may be instances when published interface information is not available. In this case, overall shielding is not to be used. Individual circuits are to be treated as they typically would for that type of interface with shielding not used in questionable cases.

For some testing performed in the past using bulk cable drive techniques, overall cable shields were routinely removed and the injected signal was applied to the core wiring within the shield. The intent of this standard is to test cables as they are configured in the installation. If the cable uses an overall shield, the test signal is applied to the overall shielded cable. If the procuring agency desires that the test be performed on the core wiring, specific wording needs to be included in contractual documentation.

40.8.5.1 (4.8.5.1) Interconnecting leads and cables.
Individual leads shall be grouped into cables in the same manner as in the actual installation. Total interconnecting cable lengths in the setup shall be the same as in the actual platform installation. If the cable is longer than 10 meters, at least 10 meters shall be included. When cable lengths are not specified for the installation, cables shall be sufficiently long to satisfy the conditions specified below. At least 2 meters (except for cables which are shorter in the actual installation) of each interconnecting cable shall be run parallel to the front boundary of the setup. Remaining cable lengths shall be routed to the back of the setup and shall be placed in a zig-zagged arrangement. When the setup includes more than one cable, individual cables shall be separated by 2 centimeters measured from their outer circumference. For bench top setups using ground planes, the cable closest to the front boundary shall be placed 10 centimeters from the front edge of the ground plane. All cables shall be supported 5 centimeters above the ground plane.

DISCUSSION: Actual lengths of cables used in installations are necessary for several reasons. At frequencies below resonance, coupling is generally proportional to cable length. Resonance conditions will be representative of the actual installation. Also, distortion and attenuation of intentional signals due strictly to cable characteristics will be present and potential susceptibility of interface circuits to induced signals will therefore be similar to the actual installation.

Zig-zagging of long cables is accomplished by first placing a length of cable in an open area and then reversing the direction of the cable run by 180 degrees each time a change of direction is required. Each subsequent segment is farther from the first. Individual segments of the cable are parallel and should be kept 2 centimeters apart. This arrangement is sometimes called a serpentine pattern. The zig-zagging of long cables rather than coiling is to control excess inductance. A 2 centimeter spacing between cables is required to expose all cabling to the test antennas and limit coupling of signals between cables. The 10 centimeter dimension for cables from the front edge of the ground plane ensures that there is sufficient ground plane surface below the first cable to be effective. The 5 centimeter standoffs standardize loop areas available for coupling and capacitance to the ground plane. The standoffs represent routing and clamping of cables in actual installations a fixed distance from structure.

In some military applications, there can be over 2000 cables associated with a subsystem. In most cases where large number of cables are involved, there will be many identical cable interfaces connected to identical circuitry. Testing of every cable interface is not necessary in this situation. The EMITP should document instances where these circumstances exist and should propose which cables are to be included in the setup and to be tested.

40.8.5.2 (4.8.5.2) Input power leads. Two meters of input power leads (including returns) shall be routed parallel to the front edge of the setup in the same manner as the interconnecting leads. The power leads shall be connected to the LISNs (see 4.6). Power leads that are part of an interconnecting cable shall be separated out at the EUT connector and routed to the LISNs. After the 2 meter exposed length, the power leads shall be terminated at the LISNs in as short a distance as possible. The total length of power lead from the EUT electrical connector to the LISNs shall not exceed 2.5 meters. All power leads shall be supported 5 centimeter above the ground plane. If the power leads are twisted in the actual installation, they shall be twisted up to the LISNs.

DISCUSSION: Appropriate power lead length is a trade-off between ensuring sufficient length for efficient coupling of radiated signals and maintaining the impedance of the LISNs. To keep a constant setup, it is undesirable to change the power lead length for different test methods. Requiring a 2 meter exposed length is consistent with treatment of interconnecting leads for radiated concerns. Wiring inductance 5 centimeter from a ground plane is approximately 1 microhenry/meter. At 1 MHz this inductance has an impedance of approximately 13 ohms which is significant with respect to the LISN requirement.

The LISN requirement standardizes impedance for power leads. While signal and control circuits are usually terminated in specified impedances, power circuit impedances are not usually well defined. The LISN requirement applies to all input prime power leads. The LISN requirement does not apply to output power leads. These leads should be terminated after the 2 meter exposed length in a load representing worst-case conditions. This load would normally draw the maximum current allowed for the power source.

The construction of the power cable between the EUT and the LISNs must be in accordance with the requirements of paragraph 4.8.5. For example, if a twisted triplet is used to distribute three phase delta power in the actual installation, the same construction should be used in the test setup. The normal construction must be interrupted over a sufficient length to permit connection to the LISNs.

40.8.6 (4.8.6) Electrical and mechanical interfaces. All electrical input and output interfaces shall be terminated with either the actual equipment from the platform installation or loads which simulate the electrical properties (impedance, grounding, balance, and so forth) present in the actual installation. Signal inputs shall be applied to all applicable electrical interfaces to exercise EUT circuitry. EUTs with mechanical outputs shall be suitably loaded. When variable electrical or mechanical loading is present in the actual installation, testing shall be performed under expected worst case conditions. When active electrical loading (such as a test set) is used, precautions shall be taken to ensure the active load meets the ambient requirements of paragraph 4.4 when connected to the setup, and that the active load does not respond to susceptibility signals. Antenna ports on the EUT shall be terminated with shielded, matched loads.

DISCUSSION: The application of signals to exercise the electrical interface is necessary to effectively evaluate performance. Most electronic subsystems on platforms are highly integrated with large amounts of digital and analog data being transferred between equipment. The use of actual platform equipment for the interfacing eliminates concerns regarding proper simulation of the interface. The interfaces must function properly in the presence of induced levels from susceptibility signals. Required isolation may be obtained by filtering the interface leads at the active load and either shielding the load or placing it outside of the shielded enclosure. The filtering should be selected to minimize the influence on the interface electrical properties specified above. For proper simulation, filtering at the loads should be outside the necessary bandwidth of the interface circuitry.

Antenna ports are terminated in loads for general setup conditions. Specific test methods address electromagnetic characteristics of antenna ports and required modifications to the test setup.

40.9 (4.9) Operation of EUT. During emission measurements, the EUT shall be placed in an operating mode which produces maximum emissions. During susceptibility testing, the EUT shall be placed in its most susceptible operating mode. For EUTs with several available modes (including software controlled operational modes), a sufficient number of modes shall be tested for emissions and susceptibility such that all circuitry is evaluated.

DISCUSSION: The particular modes selected may vary for different test methods. Considerations for maximum emissions include conditions which cause the EUT to draw maximum prime power current, result in greatest activity in interface circuit operation, and generate the largest current drain on internal digital clock signals. Settings for a radar could be adjusted such that an output waveform results which has the highest available average power. Data bus interfaces could be queried frequently to cause constant bus traffic flow. Any modes of the EUT which are considered mission critical in the installation should be evaluated during susceptibility testing.

A primary consideration for maximum susceptibility is placing the EUT in its most sensitive state for reception of intentional signals (maximum gain). An imaging sensor would normally be evaluated with a scene meeting the most stringent specifications for the sensor. RF receivers are normally evaluated using an input signal at the minimum signal to noise specification of the receiver. An additional consideration is ensuring that all electrical interfaces which intentionally receive data are exercised frequently to monitor for potential responses.

40.9.1 (4.9.1) Operating frequencies for tunable RF equipment. Measurements shall be performed with the EUT tuned to not less than three frequencies within each tuning band, tuning unit, or range of fixed channels, consisting of one mid-band frequency and a frequency within ± 5 percent from each end of each band or range of channels.

DISCUSSION: Tuned circuits and frequency synthesis circuitry inside RF equipment typically vary in characteristics such as response, rejection, and spectral content of emissions as they are set to different frequencies. Several test frequencies are required simply to obtain a sampling of the performance of the EUT across its operating range.

40.9.2 (4.9.2) Operating frequencies for spread spectrum equipment. Operating frequency requirements for two major types of spread spectrum equipment shall be as follows:

- a. Frequency hopping. Measurements shall be performed with the EUT utilizing a hop set which contains 30% of the total possible frequencies. The hop set shall be divided equally into three segments at the low, mid, and high end of the EUT's operational frequency range.
- b. Direct sequence. Measurements shall be performed with the EUT processing data at its highest possible data transfer rate.

DISCUSSION: During testing it is necessary to operate equipments at levels that they will experience during normal field operations to allow for a realistic representation of the emission profile of the EUT during radiated and conducted testing and to provide realistic loading and simulation of the EUT during radiated and conducted susceptibility testing.

Frequency hopping: Utilization of a hopset which is distributed across the entire operational spectrum of the EUT will help assure that internal circuitry dependent on the exact EUT transmit frequency being used is active intermittently during processing of the entire pseudo random stream. The fast operating times of hopping receivers/transmitters versus the allowable measurement times of the measurement receivers being used (paragraph 4.10.4) will allow a representative EUT emission signature to be captured.

Direct sequence: Requiring the utilization of the highest data transfer rate used in actual operation of the EUT should provide a representative worst-case radiated and conducted emission profile. Internal circuitry will operate at its highest processing rate when integrating the data entering the transmitter, and then resolving (disintegrating) the data back once again on the receiver end. Additionally, the data rate will need to be an area of concentration during all susceptibility testing.

40.9.3 (4.9.3) Susceptibility monitoring. The EUT shall be monitored during susceptibility testing for indications of degradation or malfunction. This monitoring is normally accomplished through the use of built-in-test (BIT), visual displays, aural outputs, and other measurements of signal outputs and interfaces. Monitoring of EUT performance through installation of special circuitry in the EUT is permissible; however, these modifications shall not influence test results.

DISCUSSION: Most EUTs can be adequately monitored through normal visual and aural outputs, self diagnostics, and electrical interfaces. The addition of special circuitry for monitoring can present questions related to its influence on the validity of the test results and may serve as an entry or exit point for electromagnetic energy.

The monitoring procedure needs to be specified in the EMITP and needs to include allowances for possible weaknesses in the monitoring process to assure the highest probability of finding regions of susceptibility.

40.10 (4.10) Use of measuring equipment. Measuring equipment shall be as specified in the individual test methods of this standard. Any frequency selective measurement receiver may be used for performing the testing described in this standard provided that the receiver characteristics (that is, sensitivity, selection of bandwidths, detector functions, dynamic range, and frequency of operation) meet the constraints specified in this standard and are sufficient to demonstrate compliance with the applicable limits of MIL-STD-461. Typical instrumentation characteristics may be found in ANSI C63.2

DISCUSSION: Questions frequently arise concerning the acceptability for use of measurement receivers other than instruments that are specifically designated "field intensity meters" or "EMI receivers". Most questions are directed toward the use of spectrum analyzers. These instruments are generally acceptable for use. However, depending on the type, they can present difficulties which are not usually encountered with the other receivers. Sensitivity may not be adequate in some frequency bands requiring that a low noise preamplifier be inserted before the analyzer input. Impulse type signals from the EUT with broad spectral content may overload the basic receiver or preamplifier. The precautions of paragraph 4.7.3 must be observed. Both of these concerns can usually be adequately addressed by the use of a preselector with the analyzer. These devices typically consist of a tunable filter which tracks the analyzer followed by a preamplifier.

ANSI C63.2 represents a coordinated position from industry on required characteristics of instrumentation receivers. This document can be consulted when assessing the performance of a particular receiver.

Many of the test methods require non-specialized instrumentation which is used for many other purposes. The test facility is responsible for selecting instrumentation which has characteristics capable of satisfying the requirements of a particular test method.

MIL-STD-462D
APPENDIX

Current probes used for EMI testing are more specialized instrumentation. These devices are current transformers with the circuit under test forming a single turn primary. They are designed to be terminated in 50 ohms. Current probes are calibrated using transfer impedance which is the ratio of the voltage output of the probe across 50 ohms to the current through the probe. Probes with higher transfer impedance provide better sensitivity. However, these probes also result in more series impedance added to the circuit with a greater potential to affect the electrical current level. The series impedance added by the probe is the transfer impedance divided by the number of turns in the secondary winding on the probe. Typical transfer impedances are 5 ohms or less. Typical added series impedance is 1 ohm or less.

40.10.1 (4.10.1) Detector. A peak detector shall be used for all frequency domain emission and susceptibility measurements. This device detects the peak value of the modulation envelope in the receiver bandpass. Measurement receivers are calibrated in terms of an equivalent root mean square (RMS) value of a sine wave that produces the same peak value. When other measurement devices such as oscilloscopes, non-selective voltmeters, or broadband field strength sensors are used for susceptibility testing, correction factors shall be applied for test signals to adjust the reading to equivalent RMS values under the peak of the modulation envelope.

DISCUSSION: The function of the peak detector and the meaning of the output indication on the measurement receiver are often confusing. Although there may appear to be an inherent discrepancy in the use of the terms "peak" and "RMS" together, there is no contradiction. All detector functions (that is peak, carrier, field intensity, and quasi-peak) process the envelope of the signal present in the receiver intermediate frequency (IF) section. All outputs are calibrated in terms of an equivalent RMS value. For a sine wave input to the receiver, the signal envelope in the IF section is a DC level and all detectors produce the same indicated RMS output. Calibration in terms of RMS is necessary for consistency. Signal sources are calibrated in terms of RMS. If a 0 dBm (107 dB μ V) unmodulated signal is applied to the receiver, the receiver must indicate 0 dBm (107 dB μ V).

If there is modulation present on the signal applied to the receiver, the detectors respond differently. The IF section of the receiver sees the portion of the applied signal within the bandwidth limits of the IF. The peak detector senses the largest level of the signal envelope in the IF and displays an output equal to the RMS value of a sine wave with the same peak. The specification of a peak detector ensures that the worst case condition for emission data is obtained. A carrier detector

MIL-STD-462D
APPENDIX

averages the modulation envelope based on selected charge and discharge time constants.

Figure A-1 shows the peak detector output for several modulation waveforms. An item of interest is that for a square wave modulated signal, which can be considered a pulse type modulation, the receiver can be considered to be displaying the RMS value of the pulse when it is on. Pulsed signals are often specified in terms of peak power. The RMS value of a signal is derived from the concept of power, and a receiver using a peak detector correctly displays the peak power.

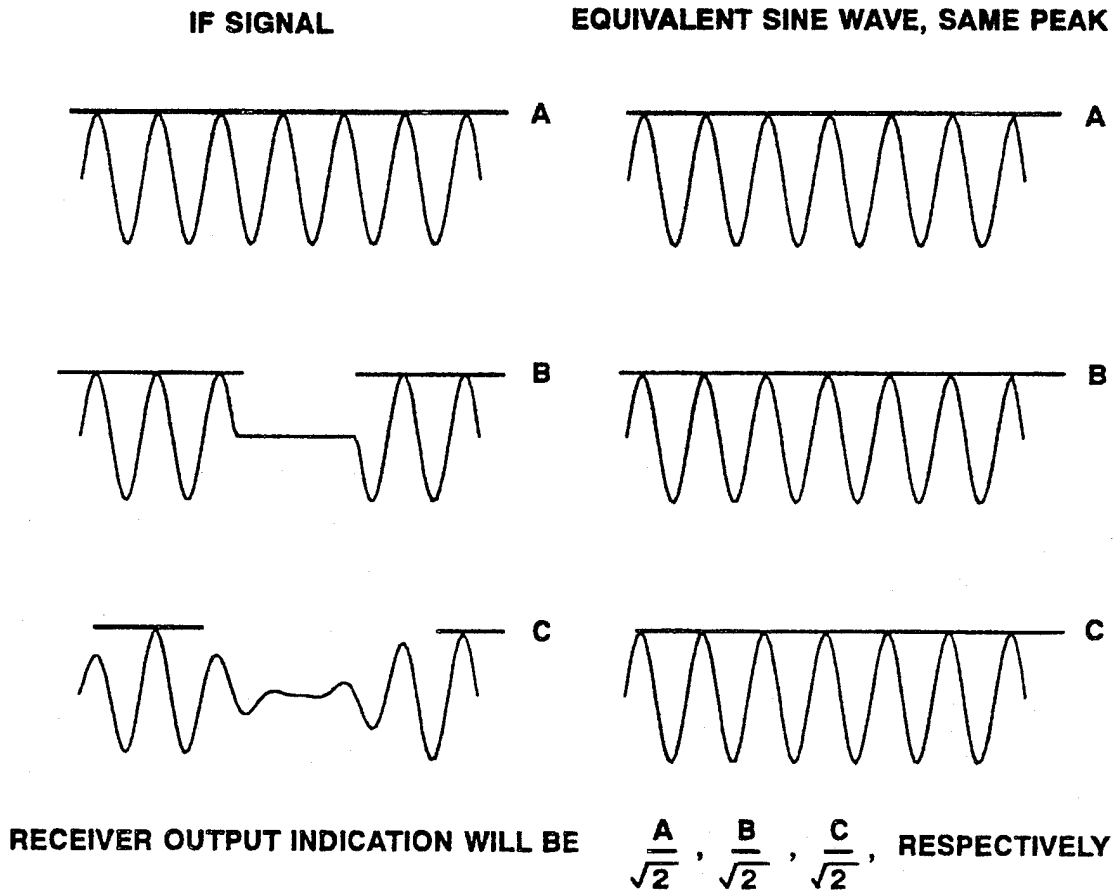

FIGURE A-1. Peak detector response.

All frequency domain measurements are standardized with respect to the response that a measurement receiver using a peak detector would provide. Therefore, when instrumentation is used which does not use peak detection, correction factors must be applied for certain signals. For an oscilloscope, the maximum

MIL-STD-462D
APPENDIX

amplitude of the modulated sine wave measured from the DC level is divided by 1.414 (square root of 2) to determine the RMS value at the peak of the modulation envelope.

Correction factors for other devices are determined by evaluating the response of the instrumentation to signals with the same peak level with and without modulation. For example, a correction factor for a broadband field sensor can be determined as follows. Place the sensor in an unmodulated field and note the reading. Apply the required modulation to the field ensuring that the peak value of the field is the same as the unmodulated field. For pulse type modulation, most signal sources will output the same peak value when modulation is applied. Amplitude modulation increases the peak amplitude of the signal and caution must be observed. Note the new reading. The correction factor is simply the reading with the unmodulated field divided by the reading with the modulated field. If the meter read 10 volts/meter without modulation and 5 volts/meter with modulation, the correction factor is 2. The evaluation should be tried at several frequencies and levels to ensure that a consistent value is obtained. When subsequently using the sensor for measurements with the evaluated modulation, the indicated reading is multiplied by the correction factor to obtain the correct reading for peak detection.

40.10.2 (4.10.2) Computer-controlled receivers. A description of the operations being directed by software for computer-controlled receivers shall be included in the EMITP required by MIL-STD-461. Verification techniques used to demonstrate proper performance of the software shall also be included.

DISCUSSION: Computer software obviously provides excellent opportunities for automating testing. However, it also can lead to errors in testing if not properly used or if incorrect code is present. It is essential that users of the software understand the functions it is executing, know how to modify parameters (such as transducer or sweep variables) as necessary, and perform sanity checks to ensure that the overall system performs as expected.

40.10.3 (4.10.3) Emission testing.

40.10.3.1 (4.10.3.1) Bandwidths. The measurement receiver bandwidths listed in Table II shall be used for emission testing. These bandwidths are specified at the 6 dB down points for the overall selectivity curve of the receivers. Video filtering shall not be used to bandwidth limit the receiver response. If a controlled video bandwidth is available on the measurement receiver, it shall be set to its greatest value. Larger bandwidths may be used; however, they may result in higher

MIL-STD-462D
APPENDIX

measured emission levels. NO BANDWIDTH CORRECTION FACTORS SHALL BE APPLIED TO TEST DATA DUE TO THE USE OF LARGER BANDWIDTHS.

TABLE II. Bandwidth and Measurement Time.

Frequency Range	6 dB Bandwidth	Dwell Time	Minimum Measurement Time Analog Measurement Receiver
30 Hz - 1 kHz	10 Hz	0.15 sec	0.015 sec/Hz
1 kHz - 10 kHz	100 Hz	0.015 sec	0.15 sec/kHz
10 kHz - 250 kHz	1 kHz	0.015 sec	0.015 sec/kHz
250 kHz - 30 MHz	10 kHz	0.015 sec	1.5 sec/MHz
30 MHz - 1 GHz	100 kHz	0.015 sec	0.15 sec/MHz
Above 1 GHz	1 MHz	0.015 sec	15 sec/GHz

DISCUSSION: The bandwidths specified in Table II are consistent with the recommended available bandwidths and the bandwidth specifications technique for receivers contained in ANSI C63.2. Existing receivers have bandwidths specified in a number of different ways. Some are given in terms of 3 dB down points. The 6 dB bandwidths are usually about 40% greater than the 3 dB values. Impulse bandwidths are usually very similar to the 6 dB bandwidths. For gaussian shaped bandpasses, the actual value is 6.8 dB.

In order not to restrict the use of presently available receivers which do not have the specified bandwidths, larger bandwidths are permitted. The use of larger bandwidths can produce higher detected levels for wide bandwidth signals. The prohibition against the use of correction factors is included to avoid any attempts to classify signals. This version of the standard has eliminated the concept of classification of emissions as broadband or narrowband in favor of fixed bandwidths and single limits specified in MIL-STD-461. Emission classification was a controversial area often poorly understood and handled inconsistently among different facilities.

40.10.3.2 (4.10.3.2) Emission identification. All emissions regardless of characteristics shall be measured with the measurement receiver bandwidths specified in Table II and compared against the limits in MIL-STD-461. Identification of emissions with regard to narrowband or broadband categorization is not applicable.

DISCUSSION: Requirements for specific bandwidths and the use of single limits are intended to resolve a number of problems.

Previous versions of this standard had no controls on required bandwidths and MIL-STD-461 provided both narrowband and broadband limits over much of the frequency range of most emission requirements. The significance of the particular bandwidths chosen for use by a test facility were addressed by classification of the appearance of the emissions with respect to the chosen bandwidths. Emissions considered to be broadband had to be normalized to equivalent levels in a 1 MHz bandwidth. The bandwidths and classification techniques used by various facilities were very inconsistent and resulted in a lack of standardization. The basic issue of emission classification was often poorly understood and implemented. Requiring specific bandwidths with a single limit eliminates any need to classify emissions.

An additional problem is that emission profiles from modern electronics are often quite complex. Some emission signatures have frequency ranges where the emissions exhibit white noise characteristics. Normalization to a 1 MHz bandwidth using spectral amplitude assumptions based on impulse noise characteristics is not technically correct. Requiring specific bandwidths eliminates normalization and this discrepancy.

40.10.3.3 (4.10.3.3) Frequency scanning. For emission measurements, the entire frequency range for each applicable test shall be scanned. Minimum measurement time for analog measurement receivers during emission testing shall be as specified in Table II. Synthesized measurement receivers shall step in one-half bandwidth increments or less, and the measurement dwell time shall be as specified in Table II.

DISCUSSION: For each emission test, the entire frequency range as specified in the applicable portion of MIL-STD-461 must be scanned to ensure that all emissions are measured.

Continuous frequency coverage is required for emission testing. Testing at discrete frequencies is not acceptable unless otherwise stated in a particular test method. The minimum scan times listed in Table II are based on two considerations. The first consideration is the response time of a particular bandwidth to an applied signal. This time is $1/(\text{filter bandwidth})$. The second consideration is the potential rates (that is modulation, cycling, and processing) at which electronics operate and the need to detect the worst case emission amplitude. Emission profiles usually vary with time. Some signals are present only at certain intervals and others vary in amplitude. For example, signals commonly present in emission profiles are harmonics of microprocessor clocks. These harmonics are very stable in frequency; however, their amplitude tends to change as various circuitry is exercised and current distribution changes.

MIL-STD-462D
APPENDIX

The first entry in the table for analog measurement receivers of 0.015 sec/Hz for a bandwidth of 10 Hz is the only one limited by the response time of the measurement receiver bandpass. The response time is $1/\text{bandwidth} = 1/10 \text{ Hz} = 0.1$ seconds. Therefore, as the receiver tunes, the receiver bandpass must include any particular frequency for 0.1 seconds implying that the minimum scan time = $0.1 \text{ seconds}/10 \text{ Hz} = 0.01 \text{ seconds/Hz}$. The value in the table has been increased to 0.015 seconds/Hz to ensure adequate time. This increase by a multiplication factor of 1.5 results in the analog receiver having a frequency in its bandpass for 0.15 seconds as it scans. This value is the dwell time specified in the table for synthesized receivers for 10 Hz bandwidths. Since synthesized receivers are required to step in one-half bandwidth increments or less and dwell for 0.15 seconds, test time for synthesized receivers will be greater than analog receivers.

The measurement times for other table entries are controlled by the requirement that the receiver bandpass include any specific frequency for a minimum of 15 milliseconds (dwell time in table), which is associated with a potential rate of variation of approximately 60 Hz. As the receiver tunes, the receiver bandpass is required to include any particular frequency for the 15 milliseconds. For the fourth entry in the table of 1.5 seconds/MHz for a 10 kHz bandwidth, the minimum measurement time is $0.015 \text{ seconds}/0.01 \text{ MHz} = 1.5 \text{ seconds/MHz}$. A calculation based on the response time of the receiver would yield a response time of $1/\text{bandwidth} = 1/10 \text{ kHz} = 0.0001 \text{ seconds}$ and a minimum measurement time of $0.0001 \text{ seconds}/0.01 \text{ MHz} = 0.01 \text{ seconds/MHz}$. The longer measurement time of 1.5 seconds/MHz is specified in the table. If the specified measurement times are not adequate to capture the maximum amplitude of the EUT emissions, longer measurement times should be implemented.

Caution must be observed in applying the measurement times. The specified parameters are not directly available on measurement receiver controls and must be interpreted for each particular receiver. Also, the specified measurement times may be too fast for some data gathering devices such as real-time X-Y recording. Measurement receiver peak hold times must be sufficiently long for the mechanical pen drive on X-Y recorders to reach the detected peak value. In addition, the scan speed must be sufficiently slow to allow the detector to discharge after the signal is detuned so that the frequency resolution requirements of paragraph 4.10.6 are satisfied.

40.10.3.4 (4.10.3.4) Emission data presentation. Amplitude versus frequency profiles of emission data shall be automatically and continuously plotted. The applicable limit shall be displayed on the plot. Manually gathered data is not acceptable except for plot verification. The plotted data for emission

MIL-STD-462D
APPENDIX

measurements shall provide a minimum frequency resolution of 1% or twice the measurement receiver bandwidth, whichever is less stringent, and a minimum amplitude resolution of 1 dB. The above resolution requirements shall be maintained in the reported results of the EMITR.

DISCUSSION: Previous versions of this standard permitted data to be taken at the three frequencies per octave for the highest amplitude emissions. This approach is no longer acceptable. Continuous displays of amplitude versus frequency are required. This information can be generated in a number of ways. The data can be plotted real-time as the receiver scans. The data can be stored in computer memory and later dumped to a plotter. Photographs of video displays are acceptable; however, it is generally more difficult to meet resolution requirements and to reproduce data in this form for submittal in an EMITR.

Placement of limits can be done in several ways. Data may be displayed with respect to actual MIL-STD-461 limit dimensions (such as dB μ V/m) with transducer, attenuation and cable loss corrections made to the data. An alternative is to plot the raw data in dB μ V (or dBm) and convert the limit to equivalent dB μ V (or dBm) dimensions using the correction factors. This second technique has the advantage of displaying the proper use of the correction factors. Since both the emission level and the required limit are known, a second party can verify proper placement. Since the actual level of the raw data is not available for the first case, this verification is not possible.

An example of adequate frequency and amplitude resolution is shown in Figure A-2. 1% frequency resolution means that two sinusoidal signals of the same amplitude separated by 1% of the tuned frequency are resolved in the output display so that they both can be seen. As shown in the figure, 1% of the measurement frequency of 5.1 MHz is 0.051 MHz and a second signal at 5.151 MHz (1 dB different in amplitude on the graph) is easily resolved in the display. The "2 times the measurement receiver bandwidth" criteria means that two sinusoidal signals of the same amplitude separated by twice the measurement receiver bandwidth are resolved. For the example shown in Figure A-2, the bandwidth is 0.01 MHz and 2 times this value is 0.02 MHz. Therefore, the 1% criterion is less stringent and is applicable. 1 dB amplitude resolution means that the amplitude of the displayed signal can be read within 1 dB. As shown in the figure, the reviewer can determine whether the signal amplitude is 60 dB μ V or 61 dB μ V.

The difference between resolution and accuracy is sometimes confusing. Paragraph 4.1.1 of the standard requires 3 dB measurement system accuracy for amplitude while paragraph 4.10.6 of the standard requires 1 dB amplitude resolution. Accuracy is an indication how precisely a value needs to be known while

MIL-STD-462D
APPENDIX

resolution is an indication of the ability to discriminate between two values. A useful analogy is reading time from a watch. A watch typically indicates the time within one second (resolution) but may be 30 seconds different than the absolute correct time (accuracy).

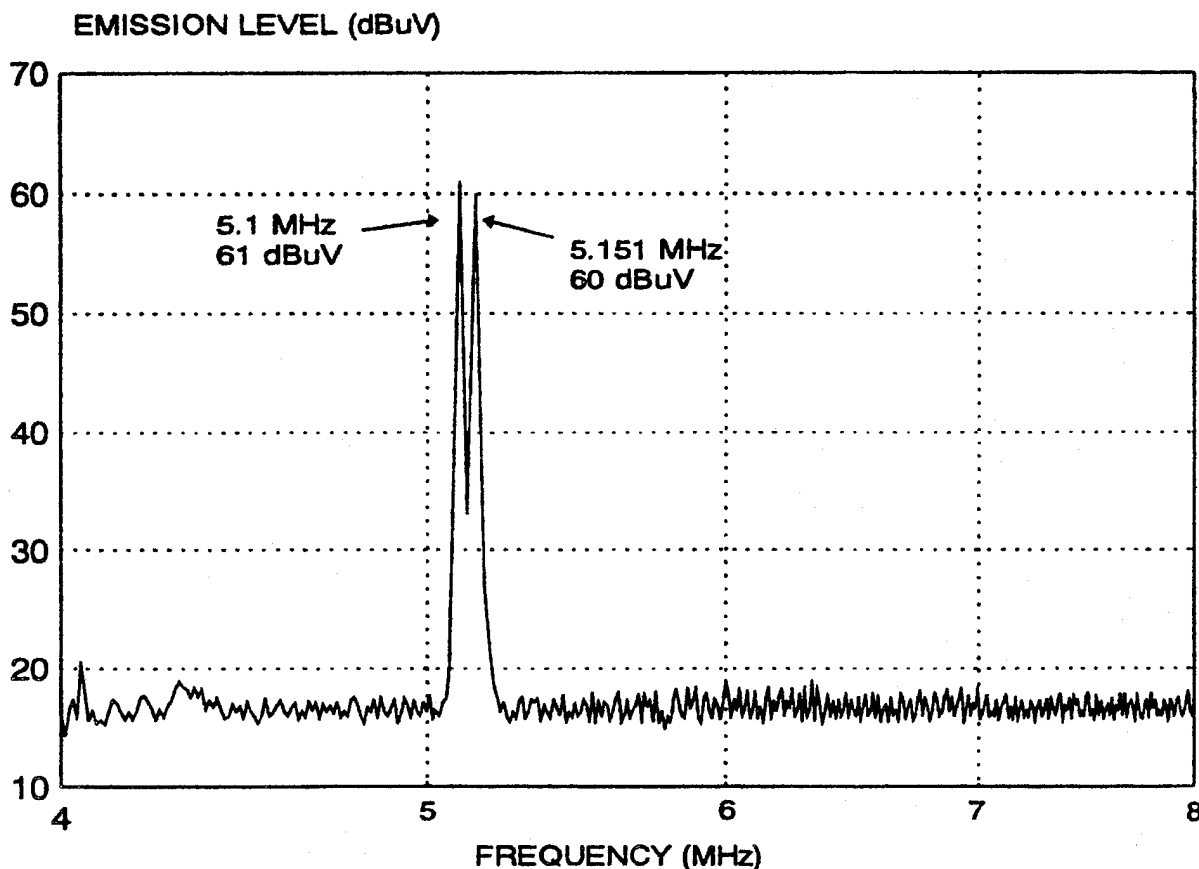

FIGURE A-2. Example of data presentation resolution.

40.10.4 (4.10.4) Susceptibility testing.

40.10.4.1 (4.10.4.1) Frequency scanning. For susceptibility measurements, the entire frequency range of each applicable test shall be scanned. For swept frequency susceptibility testing, frequency scan rates and frequency step sizes of signal sources shall not exceed the values listed in Table III. The rates and step sizes are specified in terms of a multiplier of the tuned frequency (f_0) of the signal source. Analog scans refer to signal sources which are continuously tuned. Stepped scans refer to signal sources which are sequentially tuned to discrete frequencies. Stepped scans shall dwell at each tuned frequency for a minimum of 1 second. Scan

MIL-STD-462D
APPENDIX

rates and step sizes shall be decreased when necessary to permit observation of a response.

DISCUSSION: For any susceptibility test performed in the frequency domain, the entire frequency range as specified in MIL-STD-461 must be scanned to ensure that all potentially susceptible frequencies are evaluated.

The scan rates and step sizes in Table III are structured to allow for a continuous change in value with frequency for flexibility. Computerized test systems could be programmed to change values very frequently. A more likely application is to block off selected bands for scanning and to base selections of scan rate or step size on the lowest frequency. For example, if 1 - 2 GHz were selected, the maximum scan rate would be $(0.002 \times 1 \text{ GHz})/\text{sec}$ which equals 2 MHz/sec and the maximum step size would be $0.001 \times 1 \text{ GHz}$ which equals 1 MHz. Both automatic and manual scanning are permitted.

TABLE III. Susceptibility Scanning.

Frequency Range	Analog Scans Maximum Scan Rate	Stepped Scans Maximum Step Size
30 Hz - 1 MHz	$0.02 f_o/\text{sec}$	$0.01 f_o$
1 MHz - 30 MHz	$0.01 f_o/\text{sec}$	$0.005 f_o$
30 MHz - 1 GHz	$0.005 f_o/\text{sec}$	$0.0025 f_o$
1 GHz - 8 GHz	$0.002 f_o/\text{sec}$	$0.001 f_o$
8 GHz - 40 GHz	$0.001 f_o/\text{sec}$	$0.0005 f_o$

The two primary areas of concern for frequency scanning for susceptibility testing are response times for EUTs to react to stimuli and how sharply the responses tune with frequency, normally expressed as quality factor (Q). Both of these items have been considered in the determination of the scan rates and step sizes in Table III. The table entries are generally based on the assumption of a maximum EUT response time of one second and Q values of 50, 100, 200, 500, and 1000 (increasing values as frequency increases in Table III). Since EUT responses are more likely to occur in approximately the 1 to 200 MHz range due to efficient cable coupling based on wavelength considerations, Q values have been increased somewhat to slow the scan and allow additional time for observation of EUT responses. More detailed discussions on these items follow.

The assumption of a maximum response time of one second is considered to be appropriate for a large percentage of possible cases. There are several considerations. While the electronics

MIL-STD-462D
APPENDIX

processing the interfering signal may respond quickly, the output display may take some time to react. Outputs which require mechanical motion such as meter movements or servo driven devices will generally take longer to show degradation effects than electronic displays such as video screens. Another concern is that some EUTs will only be in particularly susceptible states periodically. For example, sensors feeding information to a microprocessor are typically sampled at specific time intervals. It is important that the susceptibility stimuli be located at any critical frequencies when the sensor is sampled. The time intervals between steps and sweep rates in Table III may need to be modified for EUTs with unusually long response times.

Some concern has been expressed on the susceptibility scan rates and the impact that they would have on the length of time required to conduct a susceptibility test. The criteria of Table III allow the susceptibility scan rate to be adjusted continually as the frequency is increased; however, as a practical matter, the rate would most likely only be changed once every octave or decade. As an example, Table A-I splits the frequency spectrum up into ranges varying from octaves to decades and lists the minimum time required to conduct a susceptibility test for an analog scan. The scan rate for each range is calculated based on the start frequency for the range. The total test time to run RS103 from 1 MHz to 18 GHz is 76.3 minutes. A similar calculation for a stepped scan results in a total test time which is 2 times this value or 152.6 minutes. It must be emphasized that the scan speeds should be slowed down if the EUT response time or Q are more critical than those used to establish the values in Table III.

Q is expressed as f_0/BW where f_0 is the tuned frequency and BW is the width in frequency of the response at the 3 dB down points. For example, if a response occurred at 1 MHz at a susceptibility level of 1 volt and the same response required 1.414 volts (3 dB higher in required drive) at 0.95 and 1.05 MHz, the Q would be $1 \text{ MHz}/(1.05 - 0.95 \text{ MHz})$ or 10. Q is primarily influenced by resonances in filters, interconnecting cabling, physical structure, and cavities. The assumed Q values are based on observations from various types of testing. The step sizes in Table III are one half of the 3 dB bandwidths of the assumed value of Q ensuring that test frequencies will lie within the resonant responses.

Below approximately 200 MHz, the predominant contributors are cable and interface filter resonances. There is loading associated with these resonances which dampens the responses and limits most values of Q to less than 50. Above 200 MHz, structural resonances of enclosures and housings start playing a role and have higher values of Q due to less dampening. Above approximately 1 GHz, aperture coupling with excitation of

MIL-STD-462D
APPENDIX

cavities will be become dominant. Values of Q are dependent on frequency and on the amount of material contained in the cavity. Larger values of Q result when there is less material in the volume. A densely packaged electronics enclosure will exhibit significantly lower values of Q than an enclosure with a higher percentage of empty volume. Q is proportional to Volume/(Surface Area X Skin Depth). The value of Q also tends to increase with frequency as the associated wavelength becomes smaller. EUT designs with unusual configurations which result in high Q characteristics may require that the scan rates and step sizes in Table III be decreased for valid testing.

TABLE A-I. Susceptibility Testing Times

Frequency Range	Maximum Scan Rate	Actual Scan Time
30 Hz - 100 Hz	0.6 Hz/sec	1.9 min
100 Hz - 1 kHz	2.0 Hz/sec	7.5 min
1 kHz - 10 kHz	20.0 Hz/sec	7.5 min
10 kHz - 100 kHz	200 Hz/sec	7.5 min
100 kHz - 1 MHz	2 kHz/sec	7.5 min
1 MHz - 5 MHz	10 kHz/sec	6.6 min
5 MHz - 30 MHz	50 kHz/sec	8.3 min
30 MHz - 100 MHz	150 kHz/sec	7.8 min
100 MHz - 200 MHz	500 kHz/sec	3.3 min
200 MHz - 400 MHz	1 MHz/sec	3.3 min
400 MHz - 1 GHz	2 MHz/sec	5.0 min
1 GHz - 2 GHz	2 MHz/sec	8.4 min
2 GHz - 4 GHz	4 MHz/sec	8.4 min
4 GHz - 8 GHz	8 MHz/sec	8.4 min
8 GHz - 12 GHz	8 MHz/sec	8.4 min
12 GHz - 18 GHz	12 MHz/sec	8.4 min
18 GHz - 30 GHz	18 MHz/sec	11.1 min
30 GHz - 40 GHz	30 MHz/sec	5.6 min

RF processing equipment presents a special case requiring unique treatment. Intentionally tuned circuits for processing RF can have very high values of Q. For example, a circuit operating

MIL-STD-462D
APPENDIX

at 1 GHz with a bandwidth of 100 kHz has a Q of 1 GHz/100 kHz or 10,000.

Automatic leveling used to stabilize the amplitude of a test signal for stepped scans may require longer dwell times than one second at discrete frequencies. The signal will take time to settle and any EUT responses during the leveling process should be ignored.

40.10.4.2 (4.10.4.2.) Modulation of susceptibility signals. Susceptibility test signals above 10 kHz shall be pulse modulated at a 1 kHz rate with a 50% duty cycle unless otherwise specified in an individual test method of this standard.

DISCUSSION: Modulation is usually the effect which degrades EUT performance. The wavelengths of the RF signal cause efficient coupling to electrical cables and through apertures (at higher frequencies). Nonlinearities in the circuit elements detect the modulation on the carrier. The circuits may then respond to the modulation depending upon detected levels, circuit bandpass characteristics, and processing features.

Pulse modulation at a 1 kHz rate, 50% duty cycle, (alternately termed 1 kHz square wave modulation) is specified for several reasons. One kHz is within the bandpass of most analog circuits such as audio or video. The fast rise and fall times of the pulse causes the signal to have significant harmonic content high in frequency and can be detrimental to digital circuits. Response of electronics has been associated with energy present and a square wave results in high average power. The modulation encompasses many signal modulations encountered in actual use. The square wave is a severe form of amplitude modulation used in communications and broadcasting. It also is a high duty cycle form of pulse modulation representative of radars.

Previous versions of MIL-STD-461 required that the worst case modulation for the EUT be used. Worst case modulation usually was not known or determined. Also, worst case modulation may not be related to modulations seen in actual use or may be very specialized. The most typical modulations used below approximately 400 MHz have been amplitude modulation at either 400 or 1000 Hz (30 to 80%) or pulse modulation, 50% duty cycle, at 400 or 1000 Hz. These same modulations have been used above 400 MHz together with pulse modulation at various pulse widths and pulse repetition frequencies. Continuous wave (CW - no modulation) has also occasionally been used. CW typically produces a detected DC level in the circuitry and affects certain types of circuits. In general, experience has shown that modulation is more likely to cause degradation. CW should be included as an additional requirement when assessing circuits

which respond only to heat such as electroexplosive devices. CW should not normally be used as the only condition.

40.10.4.3 (4.10.4.3) Thresholds of susceptibility. When susceptibility indications are noted in EUT operation, a threshold level shall be determined where the susceptible condition is no longer present. Thresholds of susceptibility shall be determined as follows:

- a. When a susceptibility condition exists, reduce the interference signal until the EUT recovers.
- b. Reduce the interference signal by an additional 6 dB.
- c. Gradually increase the interference signal until the susceptibility condition reoccurs. The resulting level is the threshold of susceptibility.
- d. Record this level, frequency range of occurrence, frequency and test level of greatest susceptibility, and other test parameters, as applicable.

DISCUSSION: It is usually necessary to test at levels above MIL-STD-461 requirements to ensure that the test signal is at least at the required level. Determination of a threshold of susceptibility is necessary when degradation is present to assess whether requirements are met. This information should be included in the EMITR. Threshold levels below MIL-STD-461 requirements are unacceptable.

The specified steps to determine thresholds of susceptibility standardize a particular technique. An alternative method sometimes utilized in the past was to use the value of the applied signal where the EUT recovers (step a above) as the threshold. Hysteresis type effects are often present where different values are obtained for the two methods.

40.11 (4.11) Calibration of measuring equipment and antennas. Test equipment and accessories required for measurement in accordance with this standard shall be calibrated under an approved program in accordance with MIL-STD-45662. In particular, measurement antennas, current probes, field sensors, and other devices used in the measurement loop shall be calibrated at least every 2 years unless otherwise specified by the procuring activity, or when damage is apparent. Antenna factors and current probe transfer impedances shall be determined on an individual basis for each device.

DISCUSSION: Calibration is typically required for any measurement device whose characteristics are not verified through

use of another calibrated item during testing. For example, it is not possible during testing to determine whether an antenna used to measure radiated emissions is exhibiting correct gain characteristics. Therefore, these antennas require periodic calibration. Conversely, a power amplifier used during radiated susceptibility testing often will not require calibration since application of the proper signal level is verified through the use of a separate calibrated field sensing device. Other amplifier applications such as the use of a signal pre-amplifier in front of a measurement receiver would require calibration of the amplifier characteristics since the specific gain versus frequency response is critical and is not separately verified.

40.11.1 (4.11.1) Measurement system test. At the start of each emission test, the complete test system (including measurement receivers, cables, attenuators, couplers, and so forth) shall be verified by injecting a known signal, as stated in the individual test method, while monitoring the system output for the proper indication.

DISCUSSION: The end-to-end system check prior to emission testing is valuable in demonstrating that the overall measurement system is working properly. It evaluates many factors including proper implementation of transducer factors and cable attenuation, general condition and setting of the measurement receiver, damaged RF cables or attenuators, and proper operation of software. Details on implementation are included in the individual test methods.

40.12 (4.12) Antenna factors. Factors for electric field test antennas shall be determined in accordance with SAE ARP-958.

DISCUSSION: SAE ARP-958 provides a standard basis for determining antenna factors for electric field emission testing. A caution needs to be observed in trying to apply these factors in applications other than EMI testing. The two antenna technique for antennas such as the biconical and double ridge horns is based on far field assumptions which are not met over much of the frequency range. Although the factors produce standardized results, the true value of the electric field is not necessarily being provided through the use of the factor. Different measuring sensors need to be used when the true electric field must be known.

50.0 MEASUREMENT PROCEDURES

TEST METHOD CE101:

This test method is used to measure emissions conducted from the EUT on input power leads from 30 Hz to 10 kHz. It is not applicable to power leads which supply power to other equipment. Emission levels are determined by measuring the current present on each power lead.

The LISNs will have little influence on the results of this testing. The circuit characteristics of the LISN will help stabilize measurements near 10 kHz; however, the LISN parameters will not be significant over most of the frequency range of the test.

Current is measured because of the low impedances present over most of the frequency range of the test. Current levels will be somewhat independent of power source impedance variations as long as the impedance of the emission source is significant in relation to the power source impedance. However, at frequencies where the shielded room filters in the test facility resonate (generally between 1 and 10 kHz), influences on measured currents can be expected.

During the measurement system check, the signal generator may need to be supplemented with a power amplifier to obtain the necessary current 6 dB below the MIL-STD-461 limit.

A possible alternative measurement tool in this frequency range is wave analyzer using a Fast Fourier Transform algorithm. Use of this type of instrumentation requires specific approval by the procuring activity.

TEST METHOD CE102:

This test method is used to measure emissions conducted from the EUT on input power leads from 10 kHz to 10 MHz. It is not applicable to power leads which supply power to other equipment. Emission levels are determined by measuring the voltage present at the output port on the LISN.

The power source impedance control provided by the LISN is a critical element of this test. This control is imposed due to wide variances in characteristics of shielded room filters and power line impedances among various test agencies and to provide repeatability through standardization. The LISN standardizes this impedance. The impedance present at the EUT electrical interface is influenced by the circuit characteristics of the

MIL-STD-462D
APPENDIX

power lead wires to the LISNs. The predominant characteristic is inductance. The impedance starts to deviate noticeably at approximately 1 MHz where the lead inductance is about 13 ohms.

The upper measurement frequency is limited to 10 MHz because of resonance conditions with respect to the length of the power leads between the EUT and LISN. As noted in paragraph 4.8.5.2 of the main body of the standard, these leads are between 2.0 and 2.5 meters long. Laboratory experimentation and theory show a quarter-wave resonance close to 25 MHz for a 2.5 meter lead. In the laboratory experiment, the impedance of the power lead starts to rise significantly at 10 MHz and peaks at several thousand ohms at approximately 25 MHz. Voltage measurements at the LISN become largely irrelevant above 10 MHz.

The 0.25 microfarad coupling capacitor in the LISN allows approximately 3.6 volts to be developed across the 50 ohm termination on the signal port for 115 volt, 400 Hz, power sources. The 20 dB attenuator is specified in the test method to protect the measurement receiver and to prevent overload. 60 Hz sources pose less of a concern.

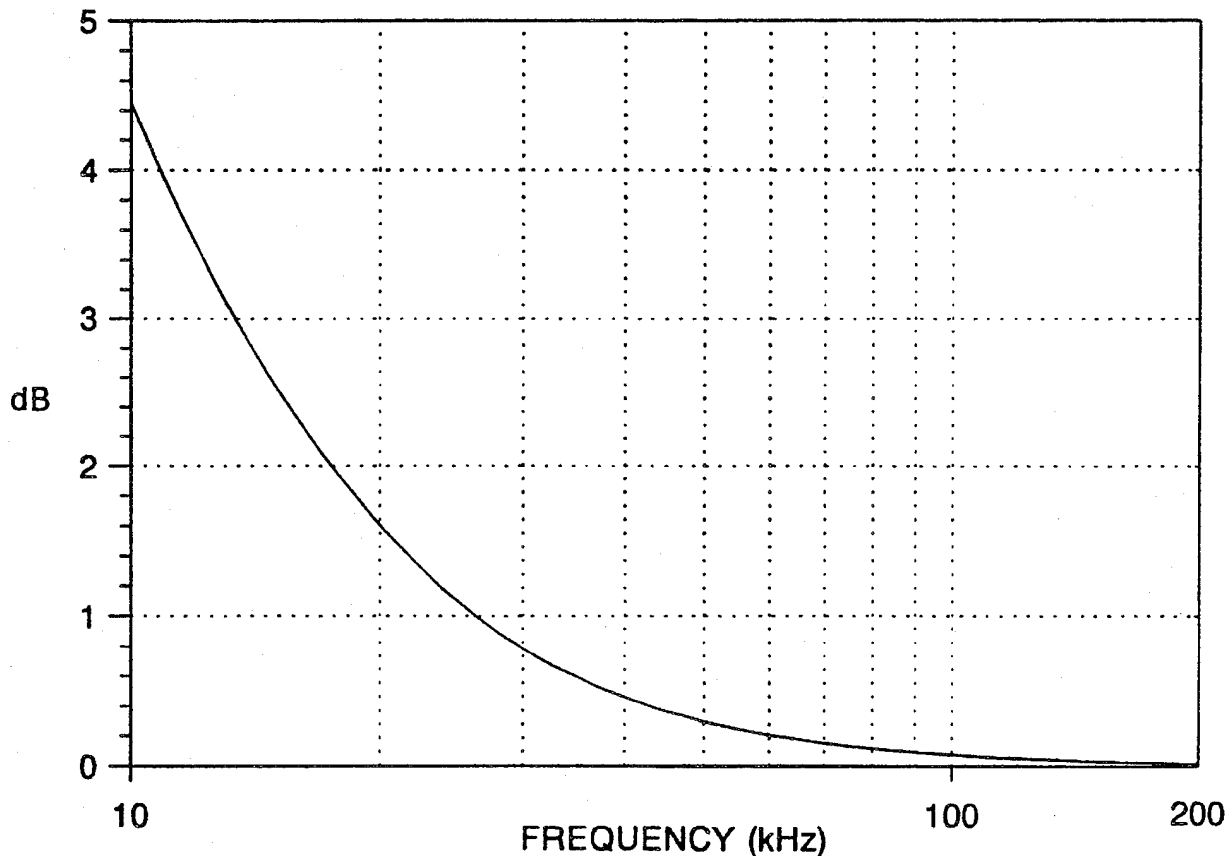

FIGURE A-3. Correction factor for LISN capacitor.

A correction factor must be included in the data reduction to account for the 20 dB attenuator and for voltage drops across the coupling capacitor. This capacitor is in series with a parallel combination of the 50 ohm measurement receiver and the 1 kilohm LISN resistor. The two parallel resistances are equivalent to 47.6 ohms. The correction factor equals $20 \log_{10} \left((1 + (7.48(10^{-5})f)^2)^{1/2} / (7.48(10^{-5})f) \right)$ where f is the frequency of interest expressed in Hz. This equation is plotted in Figure A-3. The correction factor is 4.46 dB at 10 kHz and drops rapidly with frequency.

An area of concern for this test method is the potential to overload the measurement receiver due to the current at the power frequency. Overload precautions are discussed in paragraph 4.7.3 of this standard. When an overload condition is predicted or encountered, a rejection filter can be used to attenuate the power frequency. A correction factor must be then included in the emission data to account for the filter loss with respect to frequency.

TEST METHOD CE106:

This test method is used to measure spurious and harmonic outputs appearing at the antenna port of transmitters. It is also used to measure emissions at the antenna port of receivers, amplifiers, and transmitters in the stand-by mode.

Since the test method measures emissions present on a controlled impedance, shielded, transmission line, the measurement results should be largely independent of the test setup configuration. Therefore, it is not necessary to maintain the basic test set described in the main body of this standard.

It is a direct coupled technique and does not consider the effect that the antenna system characteristics will have on actual radiated levels.

Figure CE106-1 is used for receivers, amplifiers, and transmitters in the stand-by mode. The purpose of the attenuator pad in Figure CE106-1 is to establish a low VSWR for more accurate measurements. Its nominal value is 10 dB, but it can be smaller, if necessary, to maintain measurement sensitivity.

The setup in Figure CE106-2 is used for low power transmitters in which the highest intentionally generated frequency does not exceed 26 GHz. The attenuator pad should be approximately 20 dB or large enough to reduce the output level of the transmitter sufficiently so that it does not damage or overload the measurement receiver. The rejection network in the figure is tuned to the fundamental frequency of the EUT and is intended to reduce post-pad transmitter power to a level which

MIL-STD-462D
APPENDIX

will not desensitize or induce spurious responses in the measurement receiver. Both the rejection network and RF pad losses must be adjusted to maintain adequate measurement system sensitivity. The total power reaching the measurement receiver input should not exceed the maximum allowable level specified by the manufacturer. All rejection and filter networks must be calibrated over the frequency range of measurement.

The setup of Figure CE106-3 is for transmitters with high average power. For transmitters with an integral antenna, it is usually necessary to measure the spurious emissions by the radiated method RE103.

Some caution needs to be exercised in applying Table II of the main body of this standard. For spurious and harmonic emissions of equipment in the transmit mode, it is generally desirable for the measurement receiver bandwidth to be sufficiently large to include at least 90% of the power of the signal present at a tuned frequency. This condition is required if a comparison is being made to a power requirement in a specification. Spurious and harmonic outputs generally have the same modulation characteristics as the fundamental. Since this method measures relative levels of spurious and harmonic signal with respect to the fundamental, it is not necessary for the measurement receiver to meet the above receiver bandwidth to signal bandwidth criterion. However, if the measurement receiver bandwidth does not meet the criterion and spurious and harmonic outputs are located in frequency ranges where this standard specifies a bandwidth different than that used for the fundamental, the measurement receiver bandwidth should be changed to that used at the fundamental to obtain a proper measurement.

For EUTs having waveguide transmission lines, the measurement receiver needs to be coupled to the waveguide by a waveguide to coaxial transition. Since the waveguide acts as a high-pass filter, measurements are not necessary at frequencies less than $0.8 f_{co}$, where f_{co} is the waveguide cut-off frequency.

TEST METHOD CS101:

This test method is used to verify the ability of the EUT to withstand ripple voltages present on power leads. Since the applied voltage is coupled in series using a transformer, Kirchoff's voltage law requires that the voltage appearing across the transformer output terminals must drop around the circuit loop formed by the EUT input and the power source impedance. The voltage specified by MIL-STD-461 is measured across the EUT input because part of the transformer voltage can be expected to drop across the source impedance.

MIL-STD-462D
APPENDIX

Earlier EMI standards introduced a circuit for a phase shift network which was intended to cancel out AC power waveforms and allow direct measurement of the ripple present across the EUT. While these devices very effectively cancel the power waveform, they return the incorrect value of the ripple and are not acceptable for use. The networks use the principle of inverting the phase of the input power waveform, adding it to the waveform (input power plus ripple) across the EUT, and presumably producing only the ripple as an output. For a clean power waveform, the network would perform properly. However, the portion of the ripple which drops across the power source impedance contaminates the waveform and gets recombined with the ripple across the EUT resulting in an incorrect value.

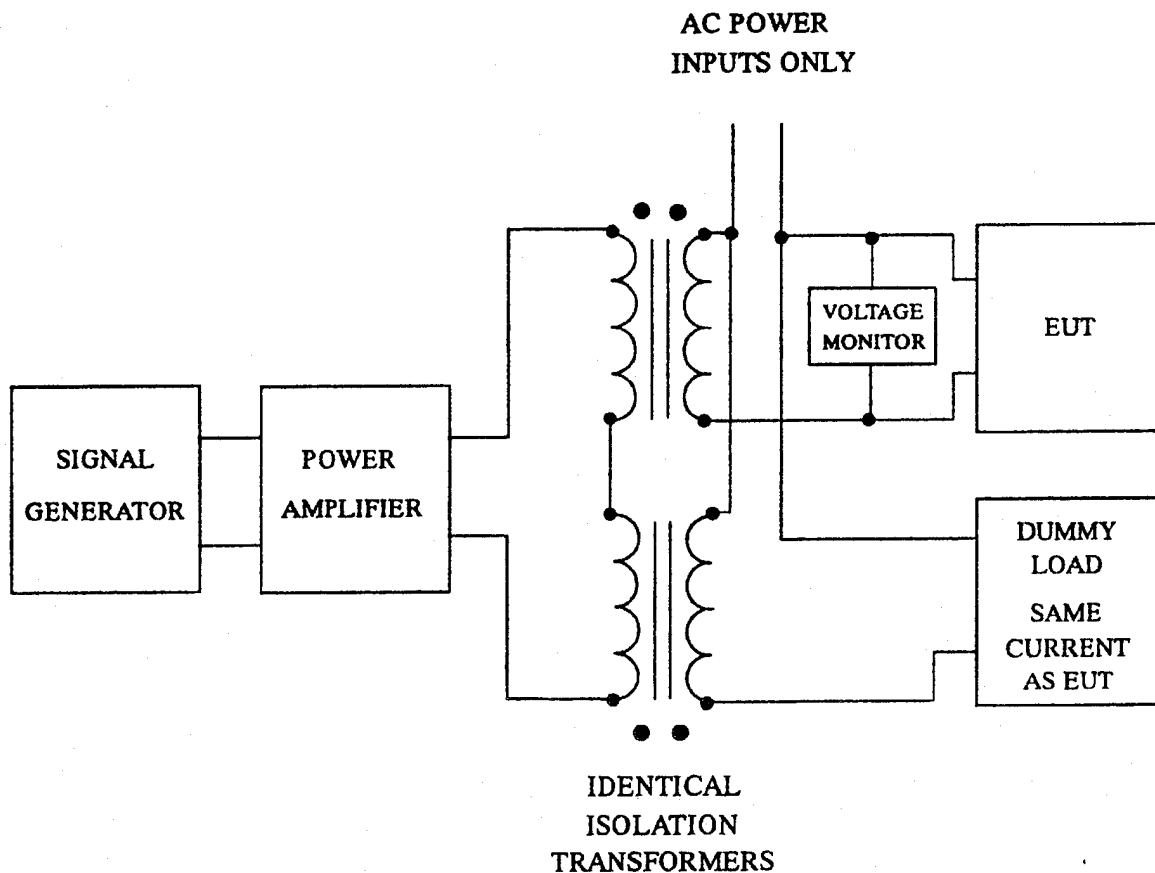

FIGURE A-4. CS101 Power amplifier protection.

Voltages will appear across the primary side of the injection transformer due to the EUT current load at the power frequency. Larger current loads will result in larger voltages

MIL-STD-462D
APPENDIX

and are the predominant concern. These voltages can cause potential problems with the power amplifier. The circuit arrangement in Figure A-4 will substantially reduce this voltage and provide protection for the amplifier. This effect is accomplished by using a dummy load equal to the EUT and wiring the additional transformer so that its induced voltage is equal to and 180 degrees out of phase with the induced voltage in the injection transformer. If possible, the dummy load should have the same power factor as the EUT.

The injected signal should be maintained as a sinusoid. Saturation of the power amplifier or coupling transformer may result in a distorted waveform.

TEST METHOD CS103:

This test method determines whether a receiver is free of responses due to intermodulation products produced in the receiver from two signals applied to the antenna port. No test method is provided in the main body of this standard for this requirement. Because of the large variety of receiver designs being developed, the requirements for the specific operational characteristics of a receiver must be established before meaningful test procedures can be developed. Only general testing techniques are discussed in this appendix.

Intermodulation testing can be applied to a variety of receiving subsystems such as receivers, RF amplifiers, transceivers and transponders.

Several receiver front-end characteristics must be known for proper testing for intermodulation responses. These characteristics generally should be determined by test. The maximum signal input that the receiver can tolerate without overload needs to be known to ensure that the test levels are reasonable and that the test truly is evaluating intermodulation effects. The bandpass characteristics of the receiver are important for determining frequencies near the receiver fundamental f_0 that will be excluded from test. Requirements for this test are generally expressed in terms of a relative degree of rejection by specifying the difference in level between potentially interfering signals and the established sensitivity of the receiver under test. Therefore, determination of the sensitivity of the receiver is a key portion of the test.

The basic concept with this test is to combine two out-of-band signals and apply them to the antenna port of the receiver while monitoring the receiver for an undesired response. One of the out-of-band signals is normally modulated with the modulation expected by the receiver. The second signal is normally continuous wave (CW). Figure A-5 shows a general setup for this

MIL-STD-462D
APPENDIX

test. For applications where the receiver would not provide an indication of interference without a receive signal being present, a third signal can be used at the fundamental. This arrangement may also be suitable for some receivers which process a very specialized type of modulation which would never be expected on an out-of-band signal. An option is for the two out-of-band signals to be CW for this application.

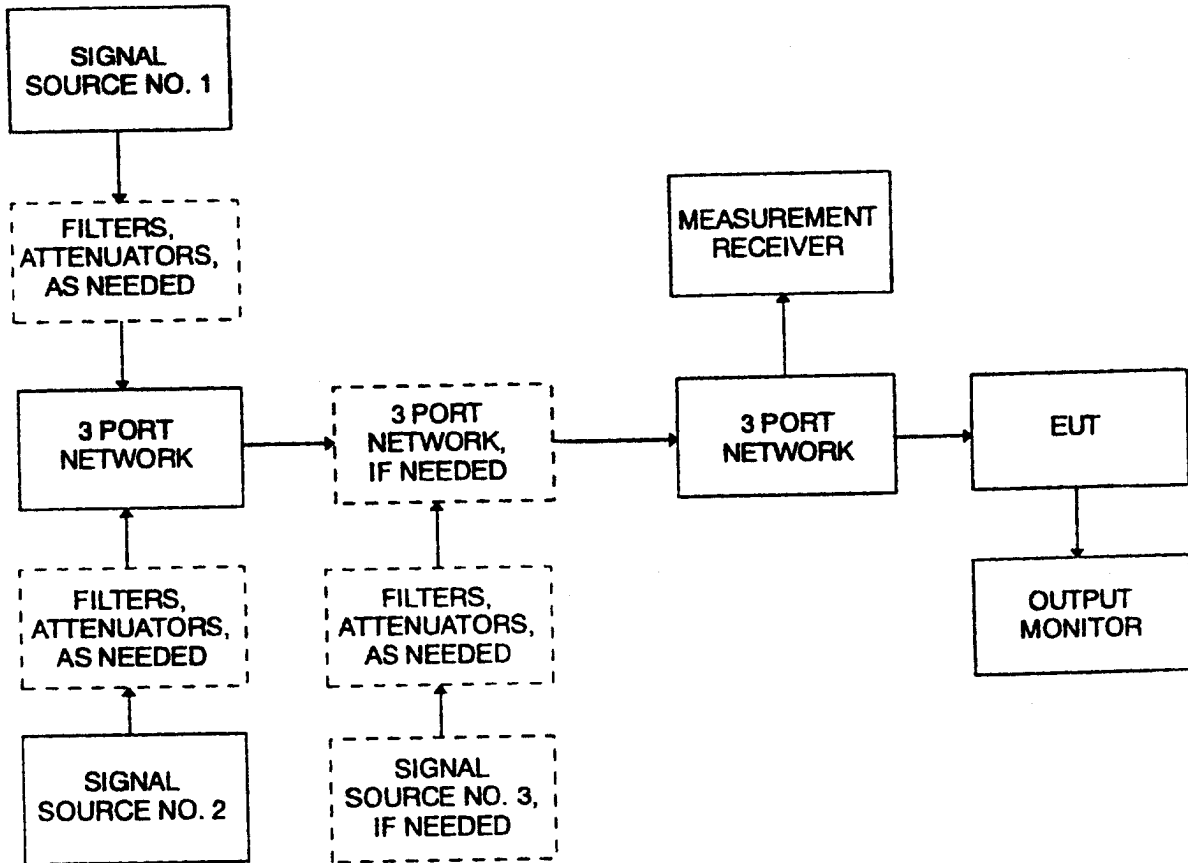

FIGURE A-5. CS103 General test setup.

The frequency of the two out-of-band signals should be set such that $f_o = 2f_1 - f_2$, where f_o is the tuned frequency of the receiver and f_1 and f_2 are the frequencies of the signal sources. This equation represents a third order intermodulation product, which is the most common response observed in receivers. f_1 and f_2 should be swept or stepped over the desired frequency range while maintaining the relationship in the equation. It is important to verify that any responses noted during this test are due to intermodulation responses. Responses can result from simply lack of rejection to one of the applied signals or from harmonics of one of the signal sources. Turning off each signal

MIL-STD-462D
APPENDIX

source in turn and noting whether the response remains can demonstrate the source of the response.

For receivers with front-end mixing and filtering in an antenna module, the test may need to be designed to be performed on a radiated basis. All signals would need to be radiated and assurances provided that any observed intermodulation products are due to the receiver and not caused by items in the test area. The EMITP would need to address antenna types, antenna locations, antenna polarizations and field measurement techniques. This test would probably need to be performed in an anechoic chamber.

For frequency hopping receivers, one possible approach is choose an f_0 within the hop set and set up the signals sources as described above. The performance of the receiver could then be evaluated as the receiver hops. If the frequency hopping receiver has a mode of operation using just one fixed frequency, this mode should also be tested.

A common error made in performing this test method is attributing failures to the EUT which are actually harmonics of the signal source or intermodulation products generated in the test setup. Therefore, it is important to verify that the signals appearing at the EUT antenna port are only the intended signals through the use of a measurement receiver as shown in Figure A-5. Damaged, corroded, and faulty components can cause signal distortion resulting in misleading results. Monitoring will also identify path losses caused by filters, attenuators, couplers, and cables.

Typical data for this test method for the EMITR are the sensitivity of the receiver, the levels of the signal sources, frequency ranges swept, operating frequencies of the receivers, and frequencies and threshold levels associated with any responses.

TEST METHOD CS104:

This test method determines whether a receiver is free of responses from out-of-band signals applied to the antenna port. No test method is provided in the main body of this standard for this requirement. Because of the large variety of receiver designs being developed, the requirements for the specific operational characteristics of a receiver must be established before meaningful test procedures can be developed. Only general testing techniques are discussed in this appendix.

Front-end rejection testing can be applied to a variety of receiving subsystems such as receivers, RF amplifiers, transceivers and transponders.

MIL-STD-462D
APPENDIX

Several receiver front-end characteristics must be known for proper testing. These characteristics generally should be determined by test. The maximum signal input that the receiver can tolerate without overload needs to be known to ensure that the test levels are reasonable. The bandpass characteristics of the receiver are important for determining frequencies near the receiver fundamental that will be excluded from testing. Requirements for this test are often expressed in terms of a relative degree of rejection by specifying the difference in level between a potentially interfering signals and the established sensitivity of the receiver under test. Therefore, determination of the sensitivity of the receiver is a key portion of the test.

The basic concept with this test method is to apply out-of-band signals to the antenna port of the receiver while monitoring the receiver for degradation. Figure A-6 shows a general test setup for this test. There are two common techniques used for performing this test using either one or two signal sources. For the one signal source method, the signal source is modulated with the modulation expected by the receiver. It is then swept over the appropriate frequency ranges while the receiver is monitored for unintended responses. With the two signal source method, a signal appropriately modulated for the receiver is applied at the tuned frequency of the receiver. The level of this signal is normally specified to be close to the sensitivity of the receiver. The second signal is unmodulated and is swept over the appropriate frequency ranges while the receiver is monitored for any change in its response to the intentional signal.

The two signal source method is more appropriate for most receivers. The one signal source method may be more appropriate for receivers which search for a signal to capture since they may respond differently once a signal has been captured. Some receivers may need to be evaluated using both methods to be completely characterized.

For frequency hopping receivers, one possible approach is to use a one signal method as if the EUT did not have a tuned frequency (include frequency scanning across the hop set) to evaluate the jamming/interference resistance of the receiver. If a frequency hopping receiver has a mode of operation using just one fixed frequency, this mode should also be tested.

For receivers with front-end mixing and filtering in an antenna module, the test may need to be designed to be performed on a radiated basis. All signals would need to be radiated and assurances provided that any observed responses are due to the receiver and not caused by items in the test area. The EMITP would need to address antenna types, antenna locations, antenna

MIL-STD-462D
APPENDIX

polarizations, and field measurement techniques. This test would probably need to be performed in an anechoic chamber.

A common error made in performing this test method is attributing failures to the EUT which are actually harmonics or spurious outputs of the signal source. Therefore, it is important to verify that the signals appearing at the EUT antenna port are only the intended signals through the use of a measurement receiver as shown in Figure A-6. Damaged, corroded, and faulty components can cause signal distortion resulting in misleading results. Monitoring will also identify path losses caused by filters, attenuators, couplers, and cables.

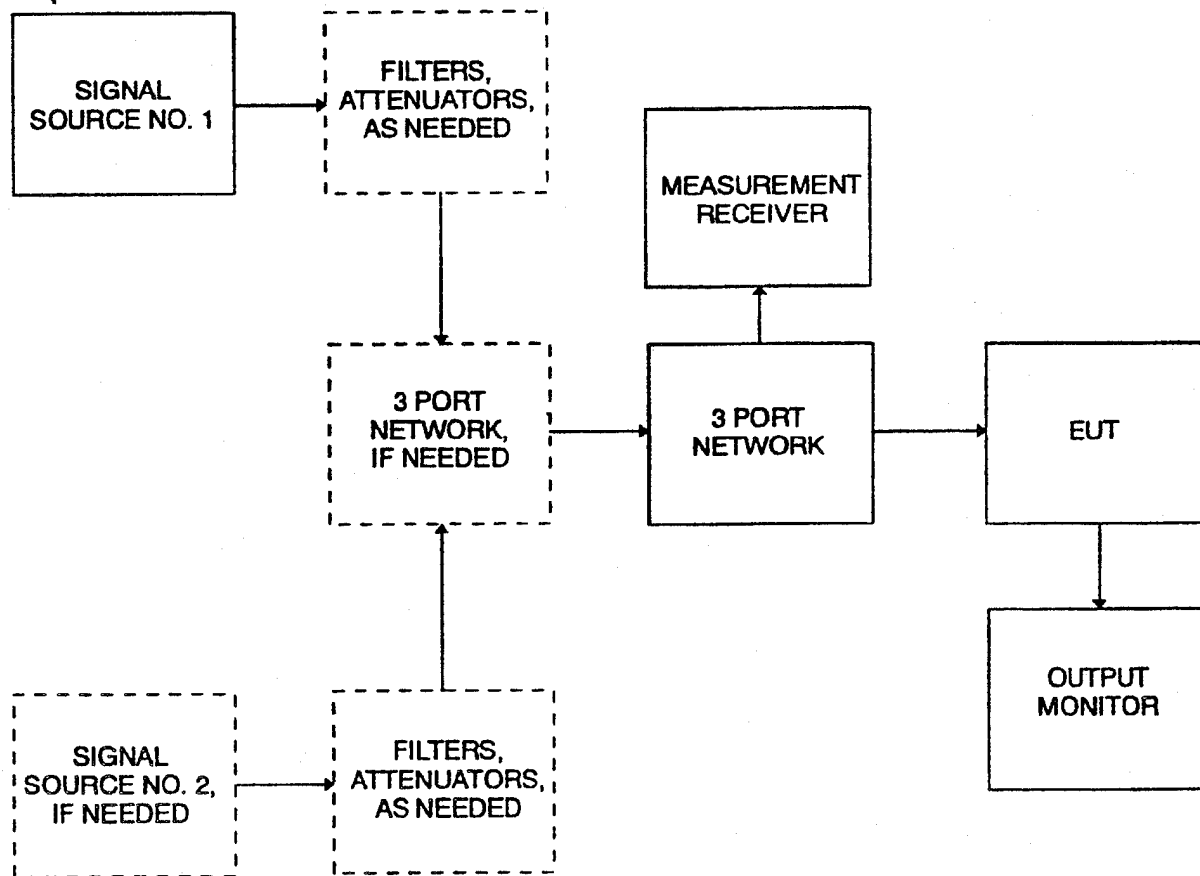

FIGURE A-6. CS104 General test setup.

Typical data for this test method for the EMITR are the sensitivity of the receiver, the levels of the signal sources, frequency ranges swept, operating frequencies of the receivers, degree of rejection (dB), and frequencies and threshold levels associated with any responses.

MIL-STD-462D
APPENDIX

TEST METHOD CS105:

This test method determines whether a receiver is free of responses due to modulation of an out-of-band signal being transferred to an in-band signal at the antenna port. No test method is provided in the main body of this standard for this requirement. Because of the large variety of receiver designs being developed, the requirements for the specific operational characteristics of a receiver must be established before meaningful test procedures can be developed. Only general testing techniques are discussed in this appendix.

Cross modulation testing should be applied only to receiving subsystems such as receivers, RF amplifiers, transceivers and transponders which extract information from the amplitude modulation of a carrier.

Several receiver front-end characteristics must be known for proper testing for cross modulation responses. These characteristics generally should be determined by test. The maximum signal input that the receiver can tolerate without overload needs to be known to ensure that the test levels are reasonable. The bandpass characteristics of the receiver are important for determining frequencies near the receiver fundamental that will be excluded from test. Requirements for this test are generally expressed in terms of a relative degree of rejection by specifying the difference in level between potentially interfering signals and the established sensitivity of the receiver under test. Therefore, determination of the sensitivity of the receiver is a key portion of the test.

The basic concept with this test is to apply a modulated signal out-of-band to the receiver and to determine whether the modulation is transferred to an unmodulated signal at the receiver's tuned frequency resulting in an undesired response. There may be cases where the in-band signal needs to be modulated if the receiver characteristics so dictate. The level of the in-band signal is normally adjusted to be close to the receiver's sensitivity. The out-of-band signal is modulated with the modulation expected by the receiver. It is then swept over the appropriate frequency ranges while the receiver is monitored for unintended responses. Testing has typically been performed over a frequency range \pm the receiver intermediate frequency (IF) centered on the receiver's tuned frequency. Figure A-7 shows a general setup for this test.

For receivers with front-end mixing and filtering in an antenna module, the test may need to be designed to be performed on a radiated basis. All signals would need to be radiated and assurances provided that any responses are due to the receiver and not caused by items in the test area. The EMITP would need

to address antenna types, antenna locations, antenna polarizations and field measurement techniques. This test would probably need to be performed in an anechoic chamber.

For frequency hopping receivers, one possible approach is choose an f_0 within the hop set and set up the signals sources as described above. The performance of the receiver could then be evaluated as the receiver hops. If the frequency hopping receiver has a mode of operation using just one fixed frequency, this mode should also be tested.

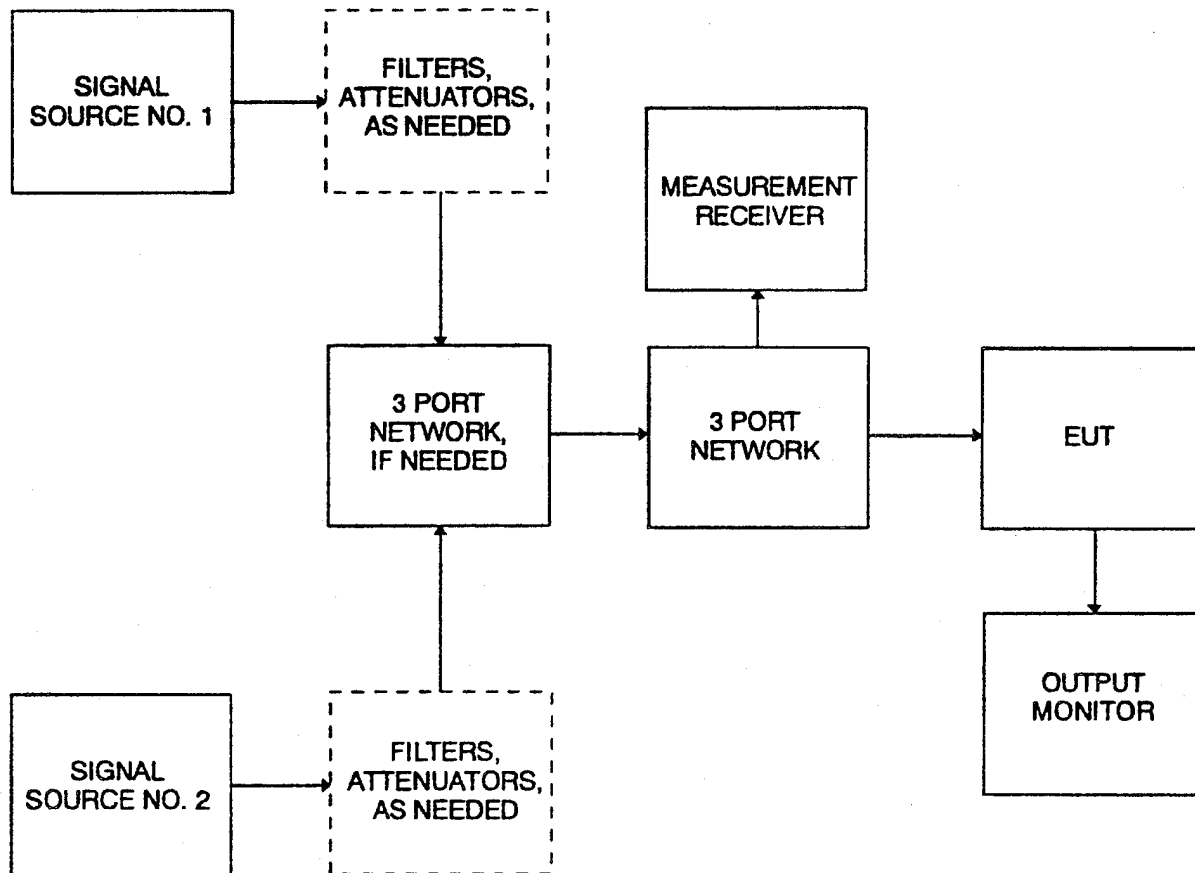

FIGURE A-7. CS105 General test setup.

It is important to verify that the signals appearing at the EUT antenna port are only the intended signals through the use of a measurement receiver as shown in Figure A-7. Damaged, corroded, and faulty components can cause signal distortion resulting in misleading results. Monitoring will also identify path losses caused by filters, attenuators, couplers, and cables.

Typical data for this test method for the EMITR are the sensitivity of the receiver, the levels of the signal sources,

MIL-STD-462D
APPENDIX

frequency ranges swept, operating frequencies of the receivers, and frequencies and threshold levels associated with any responses.

TEST METHOD CS109:

This test method is used to verify the ability of the EUT to withstand lower frequency currents flowing in its structure. It is primarily intended to evaluate EUTs which include sensitive low frequency receivers such as sonar.

Electrical connection needs to be made to the external structure of the EUT and damage to the external finish should be minimized. Screws or protuberances at ground potential near the diagonal corners of the EUT should normally be used as test points. Connections should be made with clip or clamp type leads. If convenient test points are not available at the diagonal corners, a sharply pointed test probe should be used to penetrate the finish in place of the clip or clamp type lead.

TEST METHOD CS114:

This test method is used to verify the ability of the EUT to withstand RF signals present on interconnecting cables. This type of test is often considered as a bulk current test since current is the parameter measured. However, it is important to note that the test signal is inductively coupled and that Faraday's law predicts an induced voltage in a circuit loop with the resultant current flow and voltage distribution dependent on the various impedances present.

The loop circuit impedance measurement is strictly intended to provide engineering information to assist in analysis of results obtained for associated testing performed at the platform-level. A common technique used to assess platform-level performance is to illuminate the platform with low-level electromagnetic fields while monitoring induced current levels on cabling. The CS114 results can then be used to assess design margins. However, differences in circuit impedances between the laboratory and platform can cause perturbations between laboratory and platform responses. The impedance information from the CS114 test assists in assessing these differences.

Earlier versions of MIL-STD-462 included a test method CS02 which specified capacitive coupling of a voltage onto individual power leads. As is the case for this test method, CS02 assessed the effect of voltages induced from electromagnetic fields. CS114 improves on CS02 by inducing levels on all wires at a connector interface simultaneously (common mode) which better simulates actual platform use. Also, a deficiency existed with

MIL-STD-462D
APPENDIX

CS02 since the RF signals were induced only on power leads. This test method is applicable to all EUT cabling.

An advantage of this type of conducted testing as compared to radiated susceptibility testing is that voltage and current levels can be more easily induced on the interfaces that are comparable to those present in installations. The physical dimensions of the EUT cabling in a test setup are often not large enough compared to the installation for efficient coupling at lower frequencies.

In the past, some platform-level problems on Navy aircraft could not be duplicated in the laboratory using the standard test methods in earlier versions of this standard. It was determined that differences between the aircraft installation and laboratory setups regarding the laboratory ground plane and avionics (aircraft electronics) mounting and electrical bonding practices were responsible. Most avionics are mounted in racks and on mounting brackets. At RF, the impedances to general aircraft structure for the various mounting schemes can be significantly different than they are with the avionics mounted on a laboratory ground plane. In the laboratory, it is not always possible to produce a reasonable simulation of the installation. A ground plane interference (GPI) test was developed to detect potential failures due to the higher impedance. In the GPI test, each enclosure of the EUT, in turn, is electrically isolated above the ground plane and a voltage is applied between the enclosure and the ground plane to simulate potential differences that may exist in the installation. Since CS114 provides similar common mode stresses at electrical interfaces as the GPI, the GPI is not included in this standard. However, the Navy may prefer to perform an additional susceptibility scan for aircraft applications with an inductor placed between the EUT enclosure and ground plane to more closely emulate the results of a GPI setup. The primary side of a typical CS101 injection transformer is considered to be an appropriate inductor.

CS114 has several advantages over the GPI as a general evaluation method. The GPI often results in significant current flow with little voltage developed at lower frequencies. CS114 is a controlled current test. A concern with the GPI test, which is not associated with CS114, is that the performance of interface filtering can be altered due to isolation of the enclosure from the ground plane. The results of CS114 are more useful since the controlled current can be compared with current levels present in the actual installation induced from fields. This technique has commonly been used in the past for certification of aircraft as safe to fly.

Testing is required on both entire power cables and power cables with the returns removed to evaluate common mode coupling

MIL-STD-462D
APPENDIX

to configurations which may be present in different installations. In some installations, the power returns are routed with the high side wiring. In other installations, power returns are tied to system structure near the utilization equipment with system structure being used as the power return path.

A commonly used calibration fixture is shown in Figure A-8. Other designs are available. The top is removable to permit the lower frequency probes to physically fit. The calibration fixture can be scaled to accommodate larger injection probes.

NOTE: VERTICAL CROSS-SECTION AT CENTER OF FIXTURE SHOWN

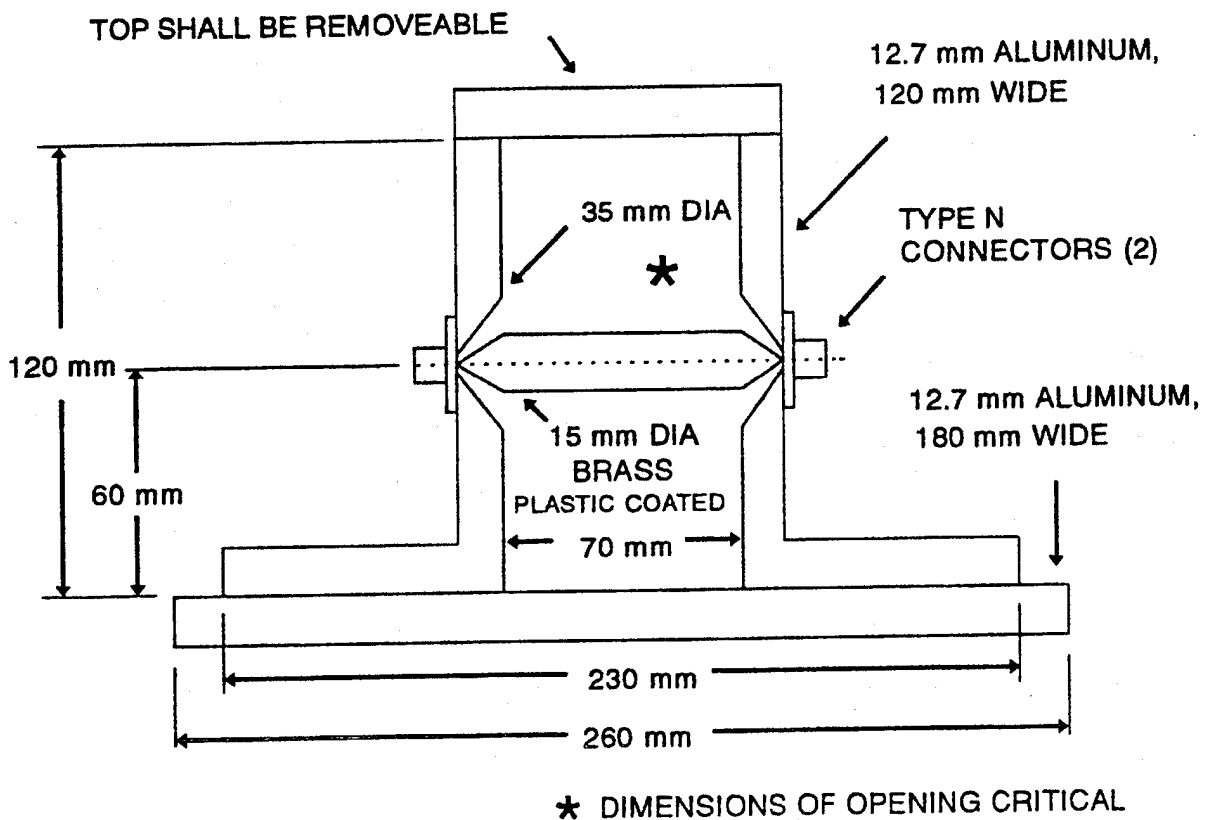

FIGURE A-8. Typical CS114 calibration fixture.

Figure A-9 shows insertion loss characteristics for typical injection probes. Insertion loss is the ratio of the power applied to the probe when installed in the calibration fixture and the power dissipated in one of the 50 ohm loads attached to the fixture. Lower insertion loss indicates more efficient

MIL-STD-462D
APPENDIX

coupling. Since power is equally divided between the two 50 ohm loads, the lowest possible loss is 3 dB. Flat characteristics with frequency are desirable to minimize the need for continuous adjustment of signal sources.

Care needs to be taken in normalizing readings to the amperes for one watt values specified in the test method since there is a square relationship between current and power. For example, if 0.001 watts of power results in 0.01 amperes of current in the calibration fixture, the current for one watt is equal to $(1 \text{ watt}/0.001 \text{ watts})^{1/2}(0.01 \text{ amperes}) = 0.32 \text{ amperes}$.

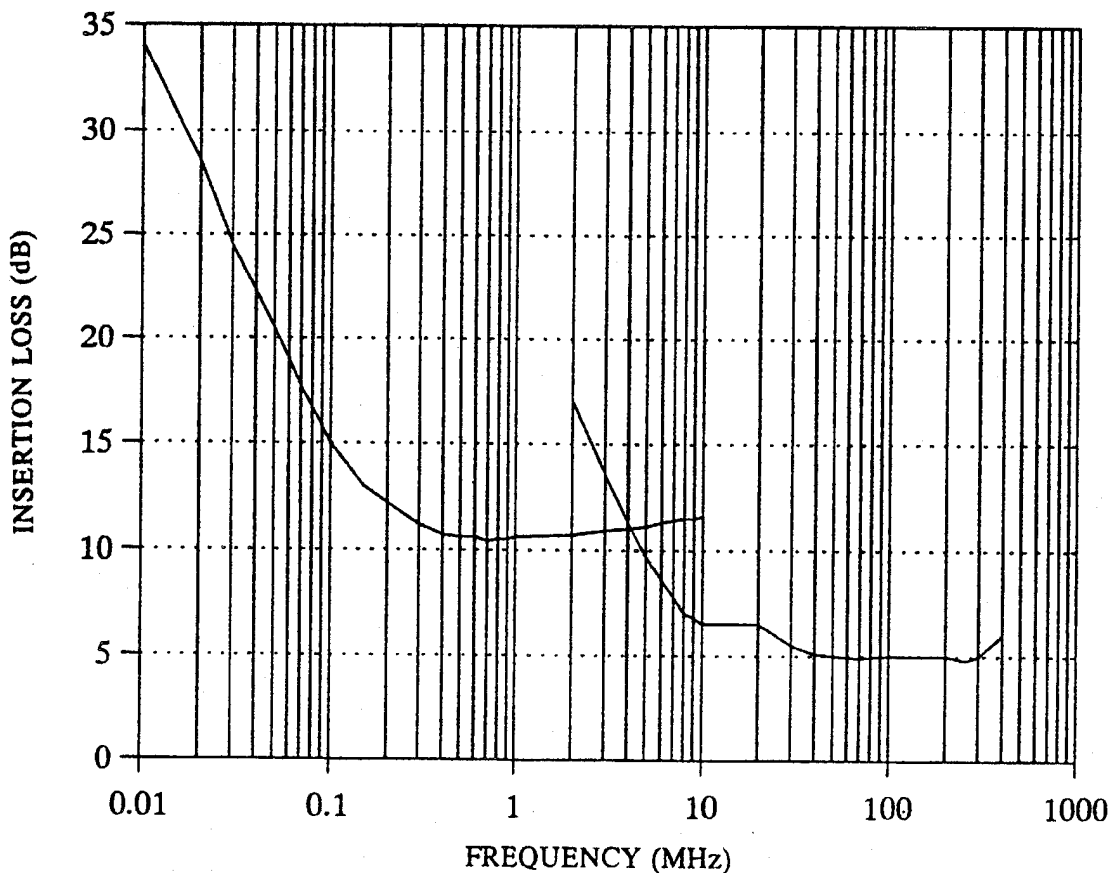

FIGURE A-9. Typical insertion loss of CS114 injection probes.

The loop circuit impedance evaluation for this test method is the same as that used in CS116. This data should be used, if available.

MIL-STD-462D
APPENDIX

Techniques using network analyzers or spectrum analyzers with tracking generators can simplify the measurements for both paragraph 4.b calibration and paragraph 4.c EUT testing portions of the method. For example, the output signal can first be set to a predetermined value such as one milliwatt and the flatness of the signal with frequency can be separately verified through a direct connection to the receiver. With this same signal then applied to the directional coupler, the induced level in the calibration fixture can be directly plotted.

TEST METHOD CS115:

This test method is used to verify the ability of the EUT to withstand transient waveforms excited by fast rise time pulses coupled onto interconnecting cables. The excitation waveform from the generator is a trapezoidal pulse. The actual waveform on the interconnecting cable will be dependent on natural resonance conditions associated with the cable and EUT interface circuit parameters.

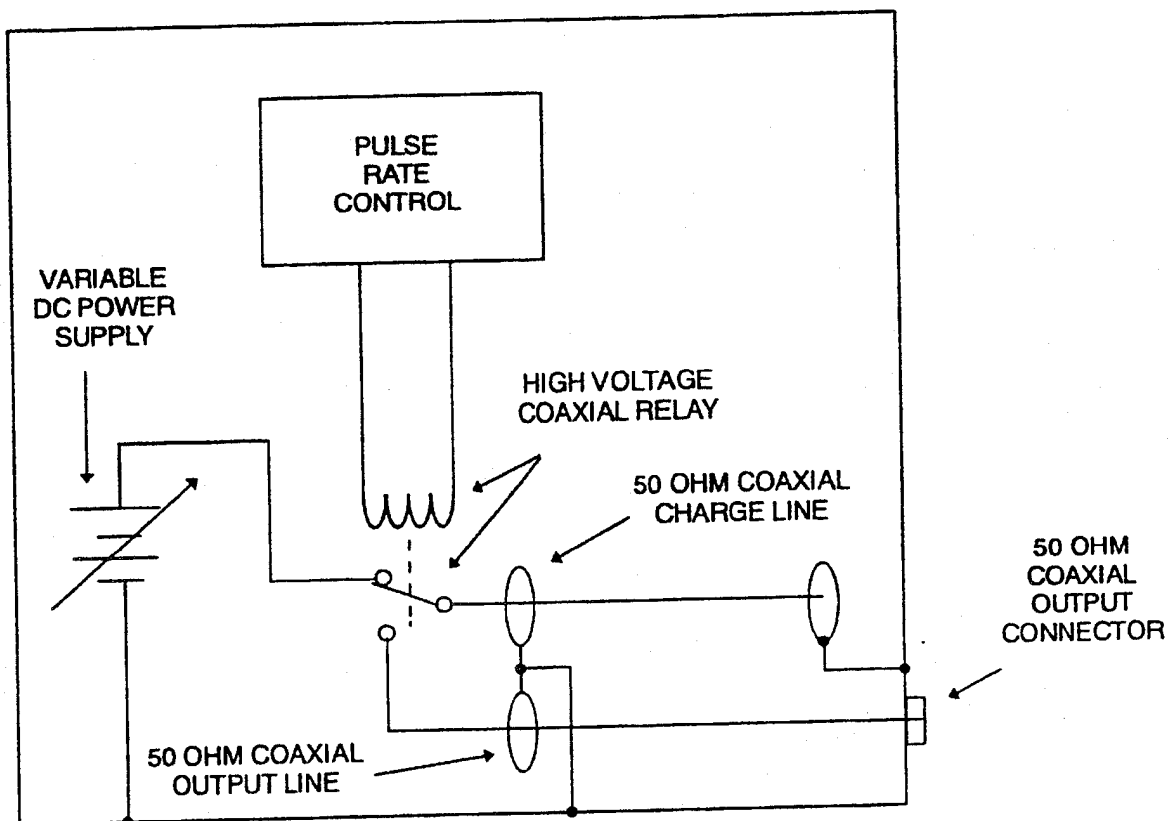

FIGURE A-10. Circuit diagram of CS115 pulse generator.

MIL-STD-462D
APPENDIX

A circuit diagram of the 50 ohm, charged line, pulse generator required by CS115 is shown in Figure A-10. Its operation is essentially the same as impulse generators used to calibrate measurement receivers except that the pulse width is much longer. A direct current power supply is used to charge the capacitance of an open-circuited 50 ohm coaxial line. The high voltage relay is then switched to the output coaxial line to produce the pulse. The pulse width is dependent upon the length of the charge line. The relay needs to have bounce-free contact operation.

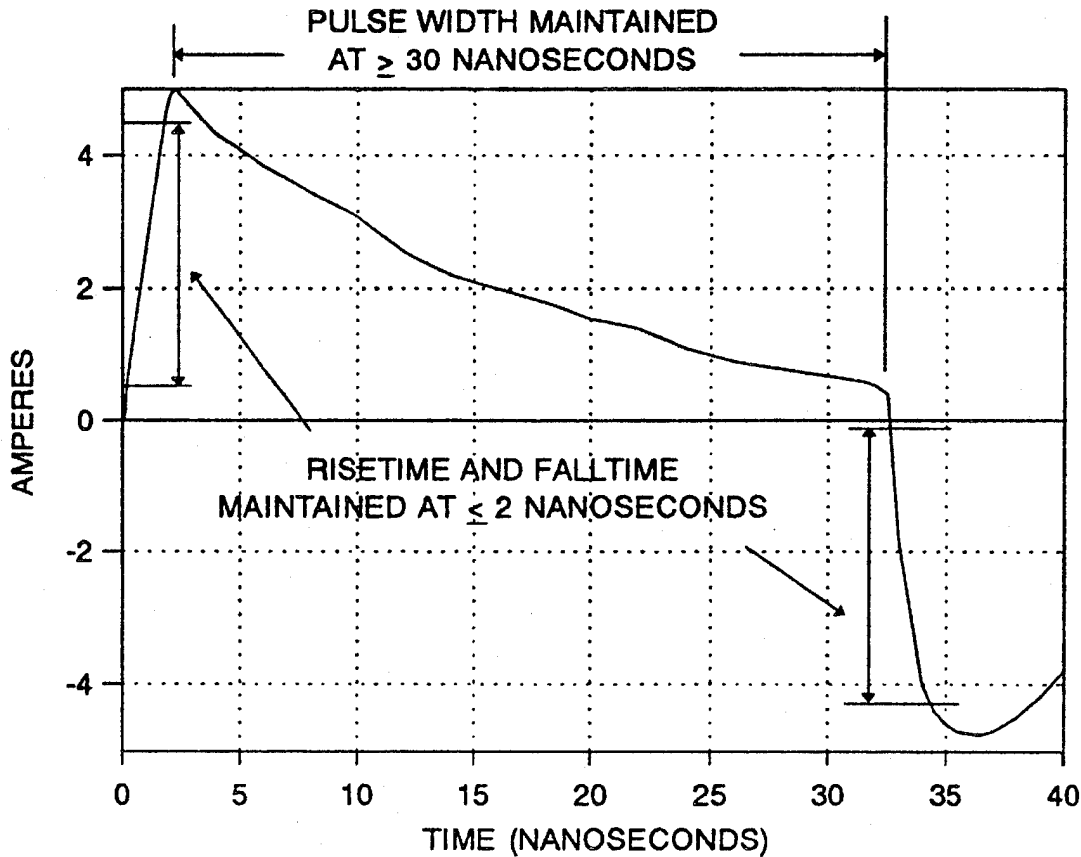

FIGURE A-11. Typical CS115 calibration fixture waveform.

Paragraph 4b(3) of CS115 requires verification that the rise time, fall time, and pulse width portions of the applied waveform are present in the observed waveform induced in the calibration fixture. Figure A-11 shows a typical waveform that will be present. Since the frequency response of injection probes falls off at lower frequencies, the trapezoidal pulse supplied to the probe sags in the middle portion of the pulse which is associated with the lower frequency content of the applied signal. The relevant parameters of the waveform are noted. It is critical

MIL-STD-462D
APPENDIX

that an injection probe be used with adequate response at higher frequencies to produce the required rise time and fall time characteristics.

As also specified in CS114, testing is required on both entire power cables and power cables with the returns removed to evaluate common mode coupling to configurations which may be present in different installations. In some installations, the power returns are routed with the high side wiring. In other installations, power returns are tied to system structure near the utilization equipment with system structure being used as the power return path.

Test method RS06 was previously included in MIL-STD-462. RS06 was a formalization of the "chattering relay" test used widely throughout the military aircraft industry. This method improves on RS06. The chattering relay has been found to be effective for determining upset conditions of equipment. The basic concept was to electrically connect the relay coil in series with a normally closed contact and allow the relay to continuously interrupt itself. The wire between the coil and contact was used to couple the transient onto EUT cables. The greatest concern with the chattering relay is that it does not produce a repeatable waveform since an arcing process is involved. The particular relay being used and the condition of its contact and coil mechanics play a large role. CS115 retains the most important characteristic of the chattering relay which is the fast rise time waveform and also has the important advantage of a consistent excitation waveform.

The same calibration fixture used for CS114 can be used for this test method. An available design is shown in Figure A-8.

TEST METHOD CS116:

This test method is used to verify the ability of the EUT to withstand damped sine transients induced onto interconnecting cables. In contrast to CS115 which excites natural resonances, the intent of this test is to control the waveform as a damped sine. Damped sine waveforms (sometimes complex combinations) are a common occurrence on platforms from both external stimuli such as lightning and electromagnetic pulse and from platform electrical switching phenomena. Waveforms appearing on cables can be due to the cable itself resonating or to voltage and current drives resulting from other resonances on the platform. Wide frequency coverage is included to account for a wide range of conditions.

MIL-STD-462 previously included test methods CS10, CS11, CS12, and CS13 which addressed various types of damped sine testing on both cables and individual circuits or connector pins.

This test method is a single replacement for all those methods. CS116 addresses testing of cables (interconnecting including power) and individual power leads. The common mode cable portion of the test is the best simulation of the type of condition present on platforms from electromagnetic field excitation. The individual power lead test addresses differential type signals present on platforms from switching functions occurring in the power system.

As necessary, the test can be applied in a straightforward manner to wires on individual pins on an EUT connector or to individual circuits (twisted pairs, coaxial cables, and so forth).

Since the quality factor (Q) of the damped sine signal results in both positive and negative peaks of significant value regardless of the polarity of the first peak, there is no requirement to switch the polarity of the injected signal.

The common mode injection technique used in this method and other methods such as CS114 is a partial simulation of the actual coupling mechanism on platforms. The magnetic field in the injection device is present at the physical location of the core of the injection device. In the platform, the electromagnetic field will be distributed in space. The injection probe induces a voltage in the circuit loops present with the voltage dropping and current flowing based on impedances present in the loop. There is a complex coupling relationship among the various individual circuits within the cable bundle. The injection probe is required to be close to the EUT connector for standardization reasons to minimize variations particularly for higher frequencies where the shorter wavelengths could affect current distribution.

A loop circuit impedance evaluation is required to identify impedance maximum and minimum. Voltage and current, respectively, will be maximized during testing at the associated frequencies, thus providing maximum stress on the EUT. This procedure is done to ensure performance of the EUT in the installation when worst-case coupling occurs. The loop circuit impedance evaluation is also required by CS114 and that data should be used when available.

TEST METHOD RE101:

This test method is used to measure magnetic field emissions radiated from the EUT and associated cabling. A 13.3 cm loop is specified for the test.

Two measurement distances of 7 and 50 centimeters are specified to allow for evaluation of potential impacts in the

MIL-STD-462D
APPENDIX

actual installation. There may be instances where potentially sensitive equipment is a sufficient distance from the point of emissions that a 50 centimeter control distance is adequate.

If the maximum level is always observed on one face or on one cable at all frequencies, then data only needs to be recorded for that face or cable.

Typical points of magnetic field emissions leakage from EUT enclosures and cables are cable shield terminations, CRT yokes, transformers and switching power supplies.

A possible alternative measurement tool in this frequency range is wave analyzer using a Fast Fourier Transform algorithm. Use of this type of instrumentation requires specific approval by the procuring activity.

TEST METHOD RE102:

This test method is used to measure electric field emissions radiating from the EUT and associated cabling.

Specific antennas are required by this method for standardization reasons. The intent is to obtain consistent results between different test facilities.

In order for adequate signal levels to be available to drive the measurement receivers, physically large antennas are necessary. Due to shielded room measurements, the antennas are required to be relatively close to the EUT, and the radiated field is not uniform across the antenna aperture. For electric field measurements below several hundred megahertz, the antennas do not measure the true electric field.

The 104 centimeter rod antenna has a theoretical electrical length of 0.5 meters and is considered to be a short monopole with an infinite ground plane. It would produce the true electric field if a sufficiently large counterpoise were used to form an image of the rod in the ground plane. However, there is not adequate room. The requirement to bond the counterpoise to the shielded room or earth ground, as applicable, is intended to improve its performance as a ground plane. The biconical and double ridged horn antennas are calibrated using far-field assumptions at a 1 meter distance. This technique produces standardized readings. However, the true electric field is obtained only above approximately 1 GHz where a far field condition exists for practical purposes.

Antenna factors are determined using the procedures of SAE ARP-958. They are used to convert the voltage at the measurement receiver to the field strength at the antenna. Any RF cable loss

and attenuator values must be added to determine the total correction to be applied.

Previous versions of this standard specified conical log spiral antennas. These antennas were convenient since they did not need to be rotated to measure both polarizations of the radiated field. The double ridged horn is considered to be better for standardization for several reasons. At some frequencies, the antenna pattern of the conical log spiral is not centered on the antenna axis. The double ridged horn does not have this problem. The circular polarization of the conical log spiral creates confusion in its proper application. Electric fields from EUTs would rarely be circularly polarized. Therefore, questions are raised concerning the need for 3 dB correction factors to account for linearly polarized signals. The same issue is present when spiral conical antennas are used for radiated susceptibility testing. If a second spiral conical is used to calibrate the field correctly for a circularly polarized wave, the question arises whether a 3 dB higher field should be used since the EUT will respond more readily to linearly polarized fields of the same magnitude.

Other linearly polarized antennas such as log periodic antennas are not to be used. It is recognized that these types of antennas have sometimes been used in the past; however, they will not necessarily produce the same results as the double ridged horn because of field variations across the antenna apertures and far field/near field issues. Uniform use of the double ridge horn is required for standardization purposes to obtain consistent results among different test facilities.

Normally, a horn antenna is used above 10 GHz. Caution should be exercised to select antennas which have patterns with broad beamwidths.

The stub radiator required by the method is simply a short wire (approximately 10 centimeters) connected to the center conductor of a coaxial cable which protrudes from the end of the cable.

There are two different mounting schemes for baluns of available 104 centimeter rod antennas with respect to the counterpoise. Some are designed to be mounted underneath the counterpoise while others are designed for top mounting. Either technique is acceptable provided the desired 0.5 meter electrical length is achieved with the mounting scheme.

The antenna positioning requirements in this method are based on likely points of radiation and antenna patterns. At frequencies below several hundred MHz, radiation is most likely to originate from EUT cabling. The 104 centimeter rod and

MIL-STD-462D
APPENDIX

biconical antennas have wide pattern coverage. The equation in Figure RE102-3 is based on the rod and biconical being placed at least every 3 meters along the test setup boundary. The double ridge horns have narrower beamwidths. However, the shorter wavelengths above 200 MHz will result in radiation from EUT apertures and portions of cabling close to EUT interfaces. The requirements for antenna positioning above 200 MHz are based on including EUT apertures and lengths of cabling at least one quarter wavelength.

All the specified antennas are linearly polarized. Above 30 MHz, measurements must be performed to measure both horizontal and vertical components of the radiated field. Measurements with the 104 centimeter rod are performed only for vertical polarization. This antenna configuration is not readily adapted for horizontal measurements.

For equipment or subsystems which have enclosures or cabling in various parts of a platform, data may need to be taken for more than one configuration. For example, in an aircraft installation where a pod is located outside of aircraft structure and its associated cabling is internal to structure, two different MIL-STD-461 limits may be applicable. Different sets of data may need to be generated to isolate different emissions from the pod housing and from cabling. The non-relevant portion of the equipment would need to be protected with appropriate shielding during each evaluation.

TEST METHOD RE103:

This test method is used to measure spurious and harmonic outputs of transmitters in the far field. It is a radiated technique and therefore includes the antenna system characteristics.

Since the test method measures emissions radiating from an antenna connected to a controlled impedance, shielded, transmission line, the measurement results should be largely independent of the test setup configuration. Therefore, it is not necessary to maintain the basic test set described in the main body of this standard.

The test methodology is laborious and will require a large open area to meet antenna separation distances. Equations in the test method specify minimum acceptable antenna separations based on antenna size and operating frequency of the EUT. Antenna pattern searches in both azimuth and elevation are required at the spurious and harmonic emissions to maximize the level of the detected signal and account for antenna characteristics.

MIL-STD-462D
APPENDIX

Sensitivity of the measurement system may need enhancement by use of preamplifiers and the entire test needs to be coordinated with local frequency allocation authorities. All recorded data has to be corrected for space loss and antenna gain before comparisons to the limit.

As shown in Figures RE103-1 and RE103-2, shielding might be necessary around the measurement system and associated RF components to prevent the generation of spurious responses in the measurement receiver. The need for such shielding can be verified by comparing measurement runs with the input connector of the measurement receiver terminated in its characteristic impedance and with the EUT in both transmitting and stand-by modes or with the EUT turned off. Also, the receiving or transmit antenna may be replaced with a dummy load to determine if any significant effects are occurring through cable coupling.

The RF cable from the receive antenna to the measurement receiver should be kept as short as possible to minimize signal loss and signal pick-up.

The band-rejection filters and networks shown in Figures RE103-1 and RE103-2 are needed to block the transmitter fundamental and thus reduce the tendency of the measurement receiver to generate spurious responses or exhibit suppression effects because of the presence of strong out-of-band signals. These rejection networks and filters require calibration over the frequency range of test.

Some caution needs to be exercised in applying Table II of the main body of this standard. In paragraph 4d(4) of the test method, a power monitor is used to measure the output power of the EUT. In conjunction with the antenna gain, this value is used to calculate the effective radiated power (ERP) of the equipment. In paragraph 4d(5) of the test method, the measurement receiver is used to measure the power from a receiving antenna. This result is also used to calculate an ERP. For the 2 measurements to be comparable, the measurement receiver bandwidth needs to be sufficiently large to include at least 90% of the power of the signal present at the tuned frequency. If the bandwidth in Table II of the main body of the standard is not appropriate, a suitable measurement receiver bandwidth should be proposed in the EMITP.

TEST METHOD RS101:

This test method is used to verify the ability of the EUT to withstand lower frequency magnetic fields. This test is primarily intended to evaluate low frequency receivers which operate within the frequency range of the test.

MIL-STD-462D
APPENDIX

Laboratory tests have been performed to assess the possibility of using the 13.3 centimeter loop sensor specified in Test Method RE101 instead of the 4 centimeter loop sensor in this test method to verify the radiated field. The testing revealed that the 13.3 centimeter loop sensor did not provide the desired result due to variation of the radiated field over the area of the loop sensor. Due to its smaller size, the 4 centimeter loop sensor provides an accurate measure of the field near the axis of the radiating loop.

TEST METHOD RS103:

This test method is used to verify that the EUT does not respond to radiated electric fields.

Test facilities are permitted to select appropriate electric field generating apparatus. Any electric field generating device such as antenna, long wire, TEM cell, reverberating chamber (when approved by the procuring activity) or parallel strip line capable of generating the required electric field may be used. Fields should be maintained as uniform as possible over the test setup boundary. Above 30 MHz, both horizontally and vertically polarized fields must be generated. This requirement may limit the use of certain types of apparatus. Only vertically polarized measurements are required below 30 MHz due to the difficulty of orienting available test equipment for horizontal measurements.

TEM cells, reverberating chambers or other unconventional techniques require approval since they may be unsuitable for certain applications. Procuring agencies must consider a number of issues in deciding whether to allow the use of these alternative techniques for a particular procurement. Issues relating to TEM cells and reverberation chambers are discussed below.

TEM cells produce relatively uniform fields at modest power input levels. TEM cells are shielded volumes with a center plate which is driven by a signal source. A plane wave is propagated between the center plate and the upper and lower surfaces. There are several concerns with TEM cells. Only vertically polarized electric fields are produced. While some EUT enclosures can be placed in several orientations for assessment, proper evaluation of coupling to any electrical interface cabling is difficult. There is usually no convenient method to expose the cabling to electric fields aligned with the cabling. Since the EUT is usually placed on the center plate (which is the driven element), the requirements in the general portion of this standard for use of ground planes cannot be implemented. Space limitations are a potential problem because of the 2 meter required lengths of cabling. Multiple EUT enclosures can exacerbate this situation.

MIL-STD-462D
APPENDIX

Reverberating chambers, using mode stirred techniques, have been popular for performing shielded effectiveness evaluations and, in some cases, have been used for radiated susceptibility testing of equipment and subsystems. The concept used in reverberating chambers is to excite available electromagnetic wave propagation modes to set up variable standing wave patterns in the chamber. A transmit antenna is used to launch a electromagnetic wave. An irregular shaped paddle wheel (mode stirrer) is rotated to excite the different modes and modify the standing wave pattern in the chamber. Any physical location in the chamber will achieve same peak field strength at some position of the paddle wheel.

Reverberation chambers have the advantage of producing relatively higher fields than other techniques for a particular power input. Also, the orientation of EUT enclosures is less critical since the all portions of the EUT will be exposed to the same peak field at some paddle wheel position. The performance of a particular reverberation chamber is dependent upon a number of factors including dimensions, Q of the chamber, number of available propagation modes, and frequency range of use.

However, there are some concerns. The field polarization and distribution with respect to the EUT layout are generally unknown at a point in time. If a problem is noted, the point of entry into the EUT may not be apparent. Since paragraph 4.10.4.2 of the main body of the standard requires a one second dwell time to allow the EUT to respond to the susceptibility signal, the paddle wheel must be maintained at each position for one second. If the paddle wheel has 100 positions, 100 seconds is required for a particular tuned frequency. The maximum step sizes listed in Table III of the main body are based on assumed Q values that could be present in the EUT and associated cabling. If the signal source is stepped in increments of the indicated sizes, test times could become excessively long. For this example, test time would be approximately 100 times greater than using a conventional radiating antenna technique. The procuring activity could approve a change to the step size or dwell time requirements taking on some risk that an EUT response would be missed at some frequencies. The performance of a particular chamber must be reviewed to determine the criticality of these concerns.

Reverberation chambers are sometimes treated as a good tool to determine potential problem frequencies with conventional antenna methods being used to evaluate areas of concern.

Monitoring requirements emphasize measuring true electric field. While emission testing for radiated electric fields does not always measure true electric field, sensors with adequate sensitivity are available for field levels generated for

MIL-STD-462D
APPENDIX

susceptibility testing. Physically small and electrically short sensors are required so that the electric field does not vary substantially over the pickup element resulting in the measurement of a localized field. Broadband sensors not requiring tuning are available.

The use of more than one sensor is acceptable provided all sensors are within the beamwidth of the transmit antenna. The effective field is determined by taking the average of the readings. For example, if the readings of three sensors are 30, 22, and 35 volts/meter, the effective electric field level is $(30 + 22 + 35)/3 = 29$ volts/meter.

Different sensors may use various techniques to measure the field. At frequencies where far-field conditions do not exist, sensors must be selected which have electric field sensing elements. Sensors which detect magnetic field or power density and convert to electric field are not acceptable. Under far-field conditions, all sensors will produce the same result. Correction factors must be applied for modulated test signals for equivalent peak detection as discussed under paragraph 4.9.1. A typical method for determining the correction factor for these sensors is as follows:

1. Generate a field at a selected frequency using an unmodulated source.
2. Adjust the field to obtain a reading on the sensor display near full scale and note the value.
3. Modulate the field as required (normally 1 kHz pulse, 50% duty cycle) and ensure the field has the same peak value. A measurement receiver with the peak detector selected and receiving antenna can be used to make this determination.
4. Note the reading on the sensor display.
5. Divide the first reading by the second reading to determine the correction factor (Subtract the two readings if the field is displayed in terms of dB).
6. Repeat the procedure at several frequencies to verify the consistency of the technique.

Above 1 GHz, radiated fields usually exhibit far-field characteristics for test purposes due to the size of typical transmit antennas, antenna patterns, and distances to the EUT. Therefore, a double ridged horn together with a measurement receiver will provide true electric field. Similarly, the particular sensing element in an isotropic sensor is not

critical, and acceptable conversions to electric field can be made.

For equipment or subsystems which have enclosures or cabling in various parts of a platform, data may need to be taken for more than one configuration. For example, in an aircraft installation where a pod is located outside of aircraft structure and its associated cabling is internal to structure, two different MIL-STD-461 limits may be applicable. Different sets of data may need to be generated to evaluate potential pod susceptibility due to coupling through the housing versus coupling from cabling. The non-relevant portion of the equipment would need to be protected with appropriate shielding.

TEST METHOD RS105:

This test method is used to verify the ability of EUT to withstand the fast rise time, free-field, transient conditions of electromagnetic pulse (EMP). It is intended to be used for equipment enclosures which are directly exposed to the incident field outside of platform structure. EUT cabling is not evaluated as part of this test. Effects due to cable coupling are tested under CS116. To protect the EUT and monitoring and simulation equipment, all cabling should be treated with overall shielding.

The EMP field is simulated in the laboratory using bounded wave TEM radiators such as TEM cells and parallel plate transmission lines. To ensure that the EUT does not significantly distort the field in the test volume, the EUT dimensions should be no more than a third of the dimension between the sides of the simulator. In these simulators the electric field is perpendicular to the surfaces of the radiator. Since the polarization of the incident EMP field in the installation is not known, the EUT must be tested in all orthogonal axes.

Since this test may cause damage to the EUT, it is advisable to first test at 50% of the specified limit, with two pulses, and then increase the amplitude slowly until the specified limit is reached.

STANDARDIZATION DOCUMENT IMPROVEMENT PROPOSAL

INSTRUCTIONS

1. The preparing activity must complete blocks 1, 2, 3, and 8. In block 1, both the document number and revision letter should be given.
2. The submitter of this form must complete blocks 4, 5, 6, and 7.
3. The preparing activity must provide a reply within 30 days from receipt of the form.

NOTE: This form may not be used to request copies of documents, nor to request waivers, or clarification of requirements on current contracts. Comments submitted on this form do not constitute or imply authorization to waive any portion of the referenced document(s) or to amend contractual requirements.

I RECOMMEND A CHANGE:	1. DOCUMENT NUMBER	2. DOCUMENT DATE (YYMMDD)
3. DOCUMENT TITLE		
4. NATURE OF CHANGE <i>(Identify paragraph number and include proposed rewrite, if possible. Attach extra sheets as needed.)</i>		
5. REASON FOR RECOMMENDATION		
6. SUBMITTER		
a. NAME <i>(Last, First, Middle Initial)</i>	b. ORGANIZATION	
c. ADDRESS <i>(Include Zip Code)</i>	d. TELEPHONE <i>(Include Area Code)</i> (1) Commercial	7. DATE SUBMITTED (YYMMDD)
	(2) AUTOVON <i>(if applicable)</i>	
8. PREPARING ACTIVITY		
a. NAME	b. TELEPHONE <i>(Include Area Code)</i> (1) Commercial (2) AUTOVON	
c. ADDRESS <i>(Include Zip Code)</i>	IF YOU DO NOT RECEIVE A REPLY WITHIN 45 DAYS, CONTACT: Defense Quality and Standardization Office 5203 Leesburg Pike, Suite 1403, Falls Church, VA 22041-3466 Telephone (703) 756-2340 AUTOVON 289-2340	