

Report No. CG-D-04-95

Experimental Determination of the Added Inertia and Damping of a 30 Degree Deadrise Planing Boat in Roll

P. Ward Brown
and
Walter E. Klosinski

Davidson Laboratory
Stevens Institute of Technology
Castle Point Station
Hoboken, NJ 07030



FINAL REPORT
JANUARY 1995

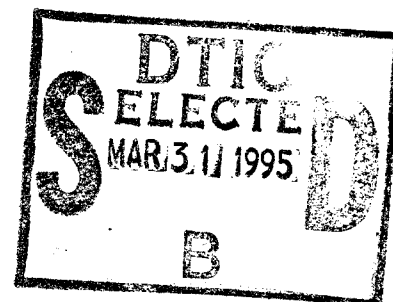

This document is available to the U.S. public through the
National Technical Information Service, Springfield, Virginia 22161

Prepared for:

U.S. Coast Guard
Research and Development Center
1082 Shennecossett Road
Groton, CT 06340-6096

and

U.S. Department Of Transportation
United States Coast Guard
Office of Engineering, Logistics, and Development
Washington, DC 20593-0001

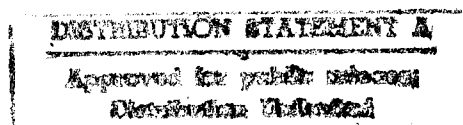

19950309 062

NOTICE

This document is disseminated under the sponsorship of the Department of Transportation in the interest of information exchange. The United States Government assumes no liability for its contents or use thereof.

The United States Government does not endorse products or manufacturers. Trade or manufacturers' names appear herein solely because they are considered essential to the object of this report.

The contents of this report reflect the views of the Coast Guard Research & Development Center. This report does not constitute a standard, specification, or regulation.



W. E. Colburn, Jr.
Technical Director, Acting
United States Coast Guard
Research & Development Center
1082 Shennecossett Road
Groton, CT 06340-6096

1. Report No. CG-D-04-95	2. Government Accession No.	3. Recipient's Catalog No.	
4. Title and Subtitle Experimental Determination of the Added Inertia and Damping of a 30 Degree Deadrise Planing Boat in Roll		5. Report Date January 1995	
		6. Performing Organization Code	
7. Author(s) P. Ward Brown and Walter E. Klosinski		8. Performing Organization Report No. R&DC 15/92	
9. Performing Organization Name and Address Davidson Laboratory Stevens Institute of Technology Castle Point Station Hoboken, NJ 07030		10. Work Unit No. (TRAIS)	
		11. Contract or Grant No. DTCG23-85-C-20060	
		13. Type of Report and Period Covered Final Report	
12. Sponsoring Agency Name and Address U.S. Coast Guard Research and Development Center 1082 Shennecossett Road Groton, Connecticut 06340-6096		14. Sponsoring Agency Code	
		Department of Transportation U.S. Coast Guard Office of Engineering, Logistics, and Development Washington, D.C. 20593-0001	
15. Supplementary Notes Coast Guard R&D Center COTR: James A. White, 203-441-2734. 			
16. Abstract <p>This is the fourth of four reports on research designed to obtain basic hydrodynamic information about planing hulls through the use of captive models tests. The information is to be used for the general study of dynamic stability while underway, course keeping, turning and maneuvering, etc. The models tested were of idealized patrol boats having an LBP of 100 ft., a beam of 20 ft., and a displacement of 100 long tons. The models had prismatic hull forms with 10, 20, and 30 degrees of deadrise.</p> <p>The report presents the results of free oscillation tests on an unappended prismatic hull with 30 degrees of deadrise. The tests were conducted at a beam loading coefficient of 0.4375, at three speeds [Cv = 1.5, 3.0, and 4.0], three trim angles [0, 3, and 6 degrees], and at yaw angles of 0, 10, and 15 degrees. Roll extinction records were taken with four different spring stiffnesses, first at rest in air and then underway in water, at each test condition. The roll period and logarithmic decrement were determined from these records and tabulated. The added mass moment of inertia and damping in roll were deduced from these data assuming a linear damped harmonic oscillator. Empirical expressions for the inertia and damping are presented and compared with the data. These expressions are used to predict the rolling characteristics of a prototype 100 ft. boat.</p>			
17. Key Words Planing boats Roll stability Roll oscillation Roll inertia Roll damping		18. Distribution Statement Document is available to the U.S. public through the National Technical Information Service, Springfield, Virginia 22161	
19. Security Classif. (of this report) UNCLASSIFIED	20. SECURITY CLASSIF. (of this page) UNCLASSIFIED	21. No. of Pages	22. Price

METRIC CONVERSION FACTORS

Approximate Conversions to Metric Measures

Symbol	When You Know	Multiply By	To Find	Symbol
LENGTH				
in	inches	* 2.5	centimeters	cm
ft	feet	30	centimeters	cm
yd	yards	0.9	meters	m
mi	miles	1.6	kilometers	km
AREA				
in ²	square inches	6.5	square centimeters	cm ²
ft ²	square feet	0.09	square meters	m ²
yd ²	square yards	0.8	square meters	m ²
mi ²	square miles	2.6	square kilometers	km ²
	acres	0.4	hectares	ha
MASS (WEIGHT)				
oz	ounces	28	grams	g
lb	pounds	0.45	kilograms	kg
	short tons (2000 lb)	0.9	tonnes	t
VOLUME				
tsp	teaspoons	5	milliliters	ml
tbsp	tablespoons	15	milliliters	ml
fl oz	fluid ounces	30	milliliters	ml
c	cups	0.24	liters	l
pt	pints	0.47	liters	l
qt	quarts	0.95	liters	l
gal	gallons	3.8	liters	l
ft ³	cubic feet	0.03	cubic meters	m ³
yd ³	cubic yards	0.76	cubic meters	m ³
TEMPERATURE (EXACT)				
°F	Fahrenheit temperature	5/9 (after subtracting 32)	Celsius temperature	°C

* 1 in = 2.54 (exactly).

Approximate Conversions from Metric Measures

Symbol	When You Know	Multiply By	To Find	Symbol
LENGTH				
mm	millimeters	0.04	inches	in
cm	centimeters	0.4	inches	in
m	meters	3.3	feet	ft
m	meters	1.1	yards	yd
km	kilometers	0.6	miles	mi
AREA				
cm ²	square centimeters	0.16	square inches	in ²
m ²	square meters	1.2	square yards	yd ²
km ²	square kilometers	0.4	square miles	mi ²
ha	hectares (10,000 m ²)	2.5	acres	
MASS (WEIGHT)				
g	grams	0.035	ounces	oz
kg	kilograms	2.2	pounds	lb
t	tonnes (1000 kg)	1.1	short tons	
VOLUME				
ml	milliliters	0.03	fluid ounces	fl oz
l	liters	0.125	cups	c
l	liters	2.1	pints	pt
l	liters	1.06	quarts	qt
l	liters	0.26	gallons	gal
m ³	cubic meters	35	cubic feet	ft ³
m ³	cubic meters	1.3	cubic yards	yd ³
TEMPERATURE (EXACT)				
°C	Celsius temperature	9/5 (then add 32)	Fahrenheit temperature	°F

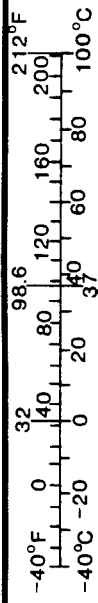

SPONSOR'S PREFACE

The Davidson Laboratory was tasked with conducting a series of passive roll oscillation tests in order to determine the hydrodynamic added mass moment of inertia in roll, and the roll damping moment, in support of roll stability studies. The model was to be free to heave and roll, but fixed in trim and yaw. The model was to be perturbed in roll and the resulting oscillations measured as a function of time using a spring loaded, passive oscillator. This was to be done at rest in air and at planing speeds in water. A second order linear model was assumed and the added moment of inertia, and damping moment, deduced from the decaying oscillatory time history. This approach was designed to provide needed data at an economical cost.

The Davidson Laboratory did an excellent job in carrying out this task. In fact the laboratory exceeded expectations in developing empirical expressions for the added mass moment of inertia and damping. It should be emphasized that these are empirical expressions that are dimensionally correct, but are without a foundation in theoretical hydrodynamics. In addition, the equations apply to the roll axis used in the experiments described in the report. Caution should therefore be exercised in applying the equations to full scale planing hulls.

The following statements are made in the DISCUSSION section of the report. First, "Unlike displacement craft, the support of a planing boat comes principally from dynamic pressure and is therefore largely independent of gravity effects. For this reason it is to be expected that the hydrodynamic added inertia of a rolling planing boat will be independent of frequency. Therefore the hydrodynamic inertia should not be affected by mechanical spring stiffness. This expectation is born out by the results." Second, "Similarly, since the hydrodynamic damping should be independent of the mechanical spring stiffness, the damping results have been collected in Table 4 and averaged."

The Project Officer for the sponsoring agency does not endorse the view that the added mass moment of inertia and the damping moment on a planing hull is independent of frequency. Approximately one third of the data was taken at a trim angle of zero degrees. Far from being supported by dynamic pressure, the model experienced considerable sinkage due to negative dynamic pressure. It is true that no consistent dependence of added mass moment of inertia or damping could be deduced from the data. This is attributed in part to scatter in the data. There are reasons to believe that an oscillating planing hull will radiate waves. This would lead to frequency dependent added mass moments of inertia and damping moments. Improvements in experimental technique, the modeling of the decaying oscillation, and data analysis are required before any definitive statement can be made on the subject of frequency dependence.

	<input checked="" type="checkbox"/>
	<input type="checkbox"/>
	<input type="checkbox"/>
APPROVED BY: 30108	
DATE: 10/11/68	
BY: [Signature]	
TITLE: [Signature]	
[Handwritten: A-1]	

TABLE OF CONTENTS

NOMENCLATURE	viii
INTRODUCTION	1
MODEL	1
APPARATUS AND INSTRUMENTATION	2
TEST PROCEDURE AND TEST PROGRAM	4
DATA PROCESSING	6
RESULTS	8
ANALYSIS	8
DISCUSSION	10
APPLICATION TO FULL SIZE BOAT	11
CONCLUDING REMARKS	13
RECOMMENDATIONS	14
ACKNOWLEDGEMENT	14
REFERENCES	15

TABLES

TABLE 1	TABLE OF PARTICULARS	16
TABLE 2	ROLL EXTINCTION RESULTS AT 30 DEGREES DEADRISE	17
TABLE 3	ADDED INERTIA AT 30 DEGREES DEADRISE	21
TABLE 4	ROLL DAMPING AT 30 DEGREES DEADRISE	22

FIGURES

FIGURE 1	LINES OF 30° DEADRISE MODEL	23
FIGURE 2	MODEL IN ROLL APPARATUS PRIOR TO RELEASE	24
FIGURE 3	SIDE VIEW OF ROLL OSCILLATION APPARATUS	25
FIGURE 4	END VIEW OF ROLL OSCILLATION APPARATUS	26
FIGURE 5	INSTALLATION OF ROLL APPARATUS IN MODEL	27
FIGURE 6	COMPARISON OF OBSERVED AND FITTED TIME HISTORY FOR RUN 95	28
FIGURE 7	VARIATION OF ROLL STIFFNESS WITH SPEED AT ZERO YAW	29
FIGURE 8	COMPARISON OF OBSERVED AND PREDICTED PERIODS	30
FIGURE 9	COMPARISON OF OBSERVED AND PREDICTED DECREMENTS	31

NOMENCLATURE

b	beam at chine, ft
CG	center of gravity
C_{Δ}	beam loading coefficient, Δ/wb^3
C_v	velocity coefficient, V/\sqrt{gb}
c	roll damping, lb-ft/radians per second
g	acceleration due to gravity, 32.17 fps ²
I	roll moment of inertia, slug-ft ²
k	roll stiffness, lb-ft/radian
T	roll period, seconds
t	time, seconds
V	velocity, fps
w	specific weight of water, 62.28 lb/cu.ft fresh water at 71.5°F
β	deadrise angle, degrees
Δ	displacement, lb
δ	roll decrement
ϕ	roll angle, radians
ψ	yaw angle, degrees
ρ	density of water, w/g, 1.9359 slugs/cu.ft at 71.5°F

Subscripts

h	hydrodynamic
m	mechanical

INTRODUCTION

The Davidson Laboratory is conducting a series of planing boat studies in support of the U.S. Coast Guard's pursuit of R&D projects that will enable it to evaluate advanced marine vehicles and advanced technologies which enhance the effectiveness of ship resources. The experimental results obtained at the Davidson Laboratory are intended to contribute to a relevant technical data base for the evaluation of vessels that are in service and for designs that are being considered for service.

The objective of this research is to obtain basic hydrodynamic information about planing hulls by captive model tests. This information is required for the study of the transverse stability, yaw/roll stability, course keeping, maneuvering and control of planing hulls, and for the study of seakeeping, and the loss of speed in a seaway of planing hulls.

The research results presented in this report are concerned with the hydrodynamic added mass moment of inertia in roll, and the roll damping moments of a prismatic planing hull having a deadrise angle of 30 degrees, and a length-beam ratio 5. The results of roll oscillation tests with this hull operating on straight course are reported. The results obtained with two earlier models in this series, having deadrise angles of 10 and 20 degrees, have been reported in Reference 1. The unappended model was tested over ranges of trim and yaw, at three speeds, and one displacement.

Measured quantities included digitized time histories of the roll extinction, from which the frequency and logarithmic decrement of the roll motion were determined. Video recordings were made of all runs.

The data are presented in tabular form. The added roll moment of inertia and the hydrodynamic roll damping are determined from an analysis of this data.

MODEL

The model series was designed at the Davidson Laboratory and approved by the Coast Guard. It is intended to provide for variations in deadrise and bow form. The parent of the model series is a 20 degree deadrise prismatic hull with flat sections and a length-beam ratio of 5. The parent model is a 1/26.66-scale model representing a boat with a design waterline length of 100

feet displacing 100 long tons. The 30 degree deadrise hull developed from the parent is also a 1/26.66-scale model and is shown on Figure 1. Hull characteristics are given in Table 1.

The forebody of the parent hull is fair and represents bow shapes that may be expected to be found on patrol boats in service at this time. The after 50% of the hull is a pure prismatic form of constant deadrise with vertical sides. The intersection of the forebody with the prismatic afterbody is smooth and fair, without abrupt changes in curvature at the transition. The transom is a plane surface normal to the keel.

The model was built of sugar pine with 3/8 inch wall thickness, glued with a powdered resin, water-resistant glue. Templates were made from the lines drawing and used during model construction. They were fitted to the model so that no light showed between the template and the model. The finish of the model included the application of one coat of Watco penetrating waterproof sealer, and five coats of Lenmar varnish with catalyzed hardener rubbed down between coats: the first coat being dry-sanded and all subsequent coats wet-sanded. The bottom of the model was given two white spray coats and finally the entire model was wet-sanded.

Spray rails were fitted at the model chines running forward from Station 5 to the stem. To ensure clean separation of the water from the chine, spray strips were fitted at the chines from Station 5 to the transom. These strips consisted of brass shim stock extending vertically downward from the model chine by 1/32 of an inch.

The model deck was covered and sealed with clear lucite. An opening was left between Stations 3 to 8 to allow for attachment to the roll oscillation apparatus, and to allow access for setting the trim angle. The 30 degree deadrise model undergoing tests is shown in the photograph on Figure 2.

APPARATUS AND INSTRUMENTATION

A special roll oscillation apparatus was designed and built by the Davidson Laboratory for these tests. Sketches of this apparatus are included in Figures 3 and 4. This is a spring loaded device with provision for locking the model at a finite roll angle. When the model is up to speed, the roll lock is released by remote command, and the resulting damped roll angle oscillation

is recorded by a rotary transducer on the roll axis. The mechanical roll stiffness can be varied by changing the coil springs; four different sets of springs were used. Provision for setting the trim and yaw of the model is included.

This "free-oscillation" mechanism is used to determine the roll moment of inertia and damping of the model, both in air and in water. The stiffness of the mechanical springs is measured, and the model oscillated while at rest in the air. A time history recording is made of the damped roll angle oscillation. The rigid body mass moment of inertia in roll is determined from the observed period of the oscillation, and the known spring stiffness. The roll damping is determined from the logarithmic decrement of the roll decay time history. (The procedure is described in the DATA PROCESSING section). The roll damping in air is found to be small, being due mostly to mechanical friction in the "free-oscillation" mechanism.

This experiment is repeated at speed in the water. The model is locked at a roll angle of 10 degrees, and released when the model is up to speed. The resulting time history of the damped oscillation is recorded from which the period and logarithmic decrement of the oscillation may be determined. In the case of the model in the water, the mechanical stiffness is augmented by the hydrodynamic roll stiffness, which must be determined by an auxiliary experiment, i.e. from Reference 2. The virtual roll moment of inertia (rigid body plus hydrodynamic) is found from the period and total stiffness, (as described in the ANALYSIS section). The added hydrodynamic roll moment of inertia is found by subtracting the rigid body roll moment of inertia (determined in air) from the virtual roll moment of inertia of the model in water. Similarly, the damping is deduced from the logarithmic decrement, and the hydrodynamic damping is found by subtracting the mechanical damping. In these tests the mechanical damping was negligible.

The roll oscillation apparatus, with provision for setting the trim and yaw angles, was mounted in the model, as shown on Figure 5. For these tests the model was free to heave but fixed in trim, and yaw. The intersection of the pitch and roll axes defines the tow point. This point was located 22.5 inches forward of the transom and 2.75 inches above the keel. Throughout this report, quantities will be given either in model scale or in units of beam. Since the beam of the models is 9 inches, the co-ordinates of the tow point are 2.5 beams forward of the transom and 0.306 beams above the keel. The roll

oscillation apparatus was attached to twin vertical heave poles in a standard free-to-heave apparatus. This apparatus includes provision for counter-weighting. The counter-weighting is used to maintain the ballasted displacement of the model, (or "load-on-water" in the case of planing craft). The free-to-heave apparatus was mounted on a standard testing carriage that was run on the Tank 3 rail. A video camera was mounted above, forward and to port of the model, and a video recording was made of each run.

The roll extinction tests were carried out in the Davidson Laboratory Tank 3 (313 ft long by 12 ft wide by 6 ft deep). A photograph of the 30 degree deadrise model being tested is included on Figure 2, which shows the model before release of the roll lock.

TEST PROCEDURE AND TEST PROGRAM

A series of preliminary runs were made with the model in water, in order to select the stiffness of the coil springs. The 30 degree deadrise model was setup in the apparatus at a model displacement of 11.49 lb, corresponding to a beam loading of 0.4375, and fixed at 3 degrees trim. Analysis of the roll decay requires a number of cycles, so that the frequency and decrement can be determined with some degree of precision. It was found that the planing hull was quite well damped in roll, becoming heavily damped at high speed. Therefore it was necessary to select very stiff mechanical springs so that the model would perform sufficient oscillations to permit analysis. Based on an analysis of the data presented in Reference 2, the natural hydrodynamic stiffness of the model was estimated to be 2.7 lb-ft per radian. The mechanical springs chosen for these tests were from 8 to 33 times as stiff.

Calibrations were performed with the model in the air. The roll transducer was calibrated in-place, and its output fed to the on-line computer. The calibration was linear and a least-squares regression analysis was performed to determine the rate. The coil springs were removed and the ballast of the model adjusted to bring the VCG onto the roll axis. Then each pair of springs was installed in turn and calibrated for stiffness. Roll moments were applied to the mechanism, the roll angular deflection determined and the roll stiffness calculated.

Oscillation experiments were carried out with the model in the air using four sets of springs, to determine the roll inertia of each model. The

carriage was moved out of the dock, and positioned under one of the rail support stanchions to provide the most rigid support for the carriage. The roll was locked at 10 degrees, then the model was released and allowed to perform free roll oscillations. The resulting time history was analyzed using 25 oscillations. The mechanical damping was negligible, with a logarithmic decrement of 0.05. The values of stiffness and roll moment of inertia for the 30 degree deadrise model on the oscillation apparatus were:

Spring Number	Stiffness lb-ft per radian	Moment of inertia slug-ft.sq
S2	22.0	0.0360
S4	36.9	0.0360
S1	66.9	0.0402
S5	89.7	0.0360

The pair of S1 springs had a weight of 0.21 lb compared to 0.05 lb for springs S2, S4, and S5, which might account for the higher model inertia determined with the S1 springs. At the model displacement of 11.49 lb, the roll moment of inertia was taken to be 0.0360 slug-ft.sq.

The following procedure was used to conduct the hydrodynamic roll extinction tests of the model at speed, at a beam loading of 0.4375. The initial tension in the port and starboard springs was adjusted so that the roll angle of the model was close to zero, and the "zero" roll angle was recorded. The model was locked at a roll angle of 10 degrees by a solenoid operated pin, and the required trim and yaw angles were set. The model was then accelerated up to speed, and data were acquired in the 100 ft data trap. Ten feet into the data trap the roll lock was released, and the resulting roll oscillation recorded. The roll channel was scanned at 250 Hz, and the time history stored in the on-line computer.

The following matrix of conditions was used for the tests of the unappended 30 degree deadrise hull:

Beam loading	0.4375
Speed, Cv	0, 1.5, 3, 4
Trim, degrees	0, 3, 6
Yaw, degrees	0, 10, 15
Spring stiffness, lb-ft per radian	22.0, 36.9, 66.9, 89.7

Video recordings were made of each run, and a selection of color still photographs were taken.

DATA PROCESSING

The data yielded by the tests consisted of time histories of the roll oscillations of the model digitized at a scan rate of 250 Hz. The equation of motion is assumed to be that of a damped harmonic oscillator of the form:

$$I\ddot{\phi} + c\dot{\phi} + k\phi = 0 \quad (1)$$

whose solution, apart from a multiplicative constant, is of the form:

$$\phi = \exp(-\delta t/T) \cos(2\pi t/T) \quad (2)$$

$$\text{where logarithmic decrement, } \delta = Tc/2I \quad (3)$$

$$\text{and period, } T = 2\pi/\sqrt{[k/I - (c/2I)^2]} \quad (4)$$

From Equations 3 and 4:

$$c = 2I\delta/T \quad (5)$$

$$k = I(4\pi^2 + \delta^2)/T^2 \quad (6)$$

which express the unknown coefficients in terms of the logarithmic decrement and period of the oscillation.

A typical roll time history is shown in Sketch A:

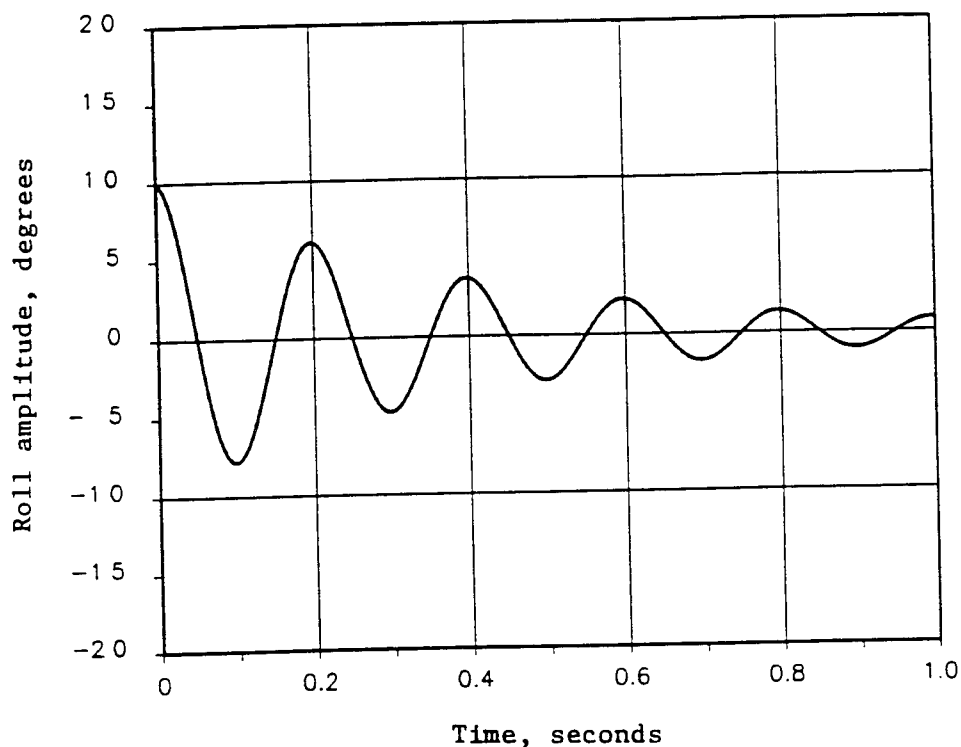

SKETCH A

Not all this time history was used in the analysis: the data prior to the first zero crossing was rejected, and the data after the amplitude decayed to less than one degree was not used. This makes for consistency in the processing, eliminates the mechanical noise associated with the initial release, and prevents the analysis of misleadingly small roll excursions.

For each time history the solution given by Equation 2 was fitted to the data using a Fortran program, "FINLIE", for fitting nonlinear equations as described by Bradley in Reference 3. The results of the fit were examined by comparing the fitted data to the observed time history in two ways: by direct comparison, and by an error plot which showed the time history of the difference between the fitted and the observed data. An example of these comparisons is shown in Figure 6 for Run 95. As well as the values of the period and logarithmic decrement determined by FINLIE, the rms of the difference between the observed and the fitted data was computed.

This analysis uses every one of the scans in the time history and is therefore superior to the analysis used in Reference 1, where only the values of the maxima and minima were used. Typically the new analysis uses 200 data points compared to 10 points in the previous analysis.

RESULTS

The results of the roll extinction tests with the 30 degree deadrise hull are presented in Table 2. For each of the four values of mechanical spring stiffness the following values are tabulated: the run number, the trim and yaw angle, the speed, the number of cycles analyzed, the values of the roll period and the logarithmic decrement determined by FINLIE, and the rms error of fit. The derived values of the added roll moment of inertia, and the roll damping are also listed in these tables.

ANALYSIS

The analysis of the data to determine the inertia and damping is carried out in model scale. The virtual roll moment of inertia (rigid body plus hydrodynamic) and the roll damping are found from Equations 5 and 6. It is assumed that the total stiffness of the oscillating system is the sum of the mechanical (rigid body) and hydrodynamic stiffnesses, and similarly that the roll inertia is the sum of the rigid body and hydrodynamic inertias.

Therefore:

$$k = k_m + k_h \quad (9)$$

$$I = I_m + I_h \quad (10)$$

From Equation 6:

$$I = kT^2/(4\pi^2 + \delta^2)$$

therefore

$$I_m + I_h = (k_m + k_h)T^2/(4\pi^2 + \delta^2)$$

hence

$$I_h = (k_m + k_h)T^2/(4\pi^2 + \delta^2) - I_m \quad (11)$$

The hydrodynamic stiffness, k_h , was found from Reference 2. The straight course roll moment data given in body axes at the pivot were used, after translation to a point 2.75 inches above the keel. The roll moment was plotted against the roll angle, and the roll stiffness estimated from these plots with the following results:

Hydrodynamic Roll Stiffness

Trim deg	Cv	Stiffness, lb-ft per radian		
		Deadrise 10°	Deadrise 20°	Deadrise 30°
0	1.5	3.96	3.74	2.50
	3.0	3.68	3.08	2.45
	4.0	1.96	1.25	1.52
3	1.5	4.13	4.09	2.84
	3.0	4.36	4.05	3.14
	4.0	4.08	3.73	2.91
6	1.5	2.12	3.11	2.79
	3.0	1.76	2.93	2.55
	4.0	2.50	4.36	3.20

The roll stiffness is shown plotted on Figure 7, and the data for the 10 and 20 degree deadrise hulls are included for comparison. A value of 2.7 lb-ft per radian was taken to apply to the 30 degree deadrise hull at all conditions. The major contribution to the total stiffness of the oscillatory system comes from the strong mechanical springs in the system. Therefore, the use of an average value for the hydrodynamic stiffness seems reasonable, since a 30% change in hydrodynamic stiffness only affects the calculated roll inertia by 5%. For the same reason, the assumption that the steady-state roll stiffness applies to dynamic roll oscillations is probably acceptable.

All quantities on the right hand side of Equation 11 are now known, so that the added hydrodynamic roll moment of inertia can be determined. This procedure was used to obtain the inertia values in the tables of results.

The damping is found by eliminating I between Equations 5 and 6 to give:

$$c = 2\delta Tk / (4\pi^2 + \delta^2) \quad (12)$$

and k is obtained from Equation 9. The damping was not corrected for the small contribution from the mechanical damping in the system. Equation 12 was used to calculate the values of roll damping in the tables.

DISCUSSION

Unlike displacement craft, the support of a planing boat comes principally from dynamic pressure and is therefore largely independent of gravity effects. For this reason it is to be expected that the hydrodynamic added inertia of a rolling planing boat will be independent of frequency. Therefore the hydrodynamic inertia should not be affected by mechanical spring stiffness. This expectation is borne out by the results. Accordingly the inertia results with the four springs have been collected in Table 3 and averaged across the springs. The hydrodynamic inertia was plotted against the mean wetted lengths given in Reference 2, and reproduced in Table 3. The following expression was deduced for the hydrodynamic roll inertia:

$$I_h = 0.010237 \rho b^5 (\ell_m/b) (1 - \sin\beta), \text{ slug-ft.sq} \quad (13)$$

The values given by this expression are included in Table 3 in the column headed "Formula". This is an empirical expression which is dimensionally correct, and fits the results within 20%. The added inertia appears to vary linearly with wetted length, but to be otherwise independent of speed, trim, and yaw angle.

Similarly, since the hydrodynamic damping should be independent of the mechanical spring stiffness, the damping results have been collected in Table 4 and averaged. An empirical expression for the damping was obtained:

$$c = wb^4 \sqrt{(b/g)} (1 - \sin\beta) [0.134 \sin|\psi| + 0.0290 C_v + 0.0199 \ell_m/b], \text{ lb-ft/rps} \quad (14)$$

The values from Equation 4 are included in Table 4 under "Formula", and agree with the measurements within about 20%. The damping increases with yaw angle, speed, and wetted length, but is otherwise independent of trim.

The variability in the data does not permit more precise formulations for the added inertia and damping characteristics. Repeated experiments with either the same or different springs often resulted in a 20% change in results.

The calculated results are compared with the observations on Figures 8 and 9 as an overall check on the empirical equations. Since the original observations consisted of the roll period and logarithmic decrement, these quantities were calculated from Equations 13 and 14 for comparison with the data. It may be noted that at very short wetted lengths (associated high speed and high trim) the experimental added inertias were often negative. This fact is not reflected in Equation 13. Nonetheless, it is considered that the periods shown on Figure 8 are quite well predicted.

On the other hand the prediction of the logarithmic decrements on Figure 9 leaves something to be desired: this scatter might be the result of having only a few oscillations to analyze.

Equations 13 and 14 are identical to those used in Reference 1.

APPLICATION TO FULL SIZE BOAT

All the results and discussion have been presented in terms of the model, and are somewhat obscured by the experimental technique. In particular the use of auxiliary springs to prolong the oscillations, thereby changing the apparent damping, may distort the appreciation of the results. To remedy this situation the dynamic roll behavior of the prototype 100 ft, 100 ton planing boat is predicted, and its damping expressed in terms of the critical damping.

The particulars of the prototype boat are given in Table A:

TABLE A

Displacement, lb	224,000
Deadrise, degrees	30
Beam, ft	20
LCG, forward of transom, ft	42
VCG, above baseline, ft	6.7
Roll stiffness, lb-ft/radian	1,560,000
Roll radius of gyration, ft	8
Roll moment of inertia, slug-ft.sq	445,600

The roll characteristics are estimated for speeds of 22.5, 45 and 60 knots, at which the mean wetted lengths are estimated to be 84.7 ft, 66.4 ft and 55.6 ft respectively, for the 42 ft LCG.

The amount of damping in a system is often expressed in terms of the critical damping. When the system is lightly damped the motion is periodic, and becomes aperiodic when it is heavily damped. Critical damping forms the demarcation point between oscillatory and non-oscillatory motion. The equation for the critical damping is:

$$c = \sqrt{(4Ik)} \quad (15)$$

The ratio of the damping to the critical damping is known as the damping factor. This and other quantities are calculated from Equations 13, 14, and 15 for zero yaw, and are presented in the following table:

TABLE B

Speed	Cv	Wetted	Added	Total	Critical	Hydro	Damping	Roll
knots		Length	Inertia	Inertia	Damping	Damping	Factor	Period
		beams	slug-ft.sq		lb-ft/rps			seconds
22.5	1.5	4.23	137,900	583,300	1,810,000	515,800	0.285	4.22
45.0	3.0	3.32	108,200	553,600	1,763,000	618,500	0.351	4.21
60.0	4.0	2.78	90,600	536,000	1,735,000	692,400	0.399	4.23

This planing boat design is moderately damped. Recovering from a roll excursion at 60 knots, the amplitude of the first overshoot would amount to 37 percent of the disturbance. With the aid of the equations for added inertia and damping, the designer can predict the roll response of his planing craft.

CONCLUDING REMARKS

A special roll apparatus was used to make roll oscillation tests of a 30 degree deadrise planing boat model while underway. The results of free oscillation tests with this apparatus are presented. The tests were made at one displacement and covered variations in speed, trim, and yaw. The hydrodynamic effects of added inertia and damping in roll are deduced, and expressions for these quantities are obtained in terms of the craft's geometry and operating conditions. These expressions are the same as those presented in Reference 1. The correlation between the formulae and the data is presented. The equations are used to predict the response of a 100 ft planing craft at speeds up to 60 knots.

The expressions for the hydrodynamic roll inertia and roll damping are:

$$I_h = 0.010237 \rho b^5 (\ell_m/b) (1 - \sin\beta), \text{ slug-ft.sq}$$

$$c = wb^4 \sqrt{(b/g)} (1 - \sin\beta) [0.134 \sin|\psi| + 0.0290 C_v + 0.0199 \ell_m/b], \text{ lb-ft/rps}$$

These empirical equations are based on limited data, and have the following ranges of applicability:

Parameter	Range
C_Δ	0.4375
ℓ_m/b	1 to 5
C_v	1.5 to 4.0
Deadrise, degrees	10 to 30
Trim, degrees	0 to 6
Yaw, degrees	-15 to +15

Although the data were obtained at one displacement, it is hoped that

the inclusion of the mean wetted length-beam ratio in the expressions will alleviate this restriction.

RECOMMENDATIONS

Some lessons were learned in working with the new roll oscillation apparatus that should be recorded for future use. The first of these concerns the roll angle zero. With the model setup in the roll apparatus, but free to roll, tests should be run at each value of trim, yaw and speed to determine the steady state roll angle. This steady state value should be used as the appropriate zero roll angle for each of the test conditions. Underwater pictures should be taken to determine the wetted lengths while these steady state tests are being conducted. Since the hydrodynamic stiffness must be known in order to analyze the results, steady state tests should be run at several applied roll moments and the roll angles measured. At present, the apparatus does not work as smoothly as would be desirable, partly due to the initial release of the roll lock, and partly due to interferences in the spring mechanism just at the point where the roll velocity changes direction. Both these defects inject noise into the roll angle signal. Consideration might be given to replacing the coil springs with a longitudinal torsion bar.

From the hydrodynamic point of view, in future tests it would be desirable to determine the effect on the roll inertia and damping of changing the displacement.

ACKNOWLEDGEMENT

The authors would like to thank Dr. Glenn McKee, Head of the Davidson Laboratory Mathematical Services Support Division, for developing and testing the many time-history-fitting algorithms that were investigated during this study. A matrix was developed which allowed for the exploration of different strategies, while preserving flexibility of use and supporting various display modes.

REFERENCES

1. Brown, P. Ward, and Klosinski, Walter E.: Experimental Determination of the Added Inertia and Damping of Planing Boats in Roll
Davidson Laboratory Report 2632, March 1991
2. Brown, P. Ward, and Klosinski, Walter E.: Directional Stability Tests of a 30 Degree Deadrise Prismatic Planing Hull
Davidson Laboratory Report 2658, March 1991
3. Bradley, James W.: FINLIE - A FORTRAN Program for Fitting Ordinary Differential Equations with Nonlinear Parameters to Data
U.S. Army Ballistics Research Laboratory Technical Report ARBL-TR-02290, February 1981

TABLE 1

TABLE OF PARTICULARS

	Model	Full Size
Scale	1/26.66	1/1
Displacement	11.49 lb	100 long tons
Load coefficient	0.4375	0.4375
Beam	9 in	20 ft
Lengths		
Overall, LOA	50 in	110 ft
Projected chine LP	47.5 in	105 ft
Design, DWL or LBP	45 in	100 ft
Length-beam ratios		
Overall	5.50	5.50
Projected Chine	5.25	5.25
Between perpendiculars	5.00	5.00
Tow point		
Forward of transom	22.5 in	
Above keel	2.75 in	

TABLE 2.1

ROLL EXTINCTION RESULTS - 30 DEGREE DEADRISE

SPRING STIFFNESS 22.0 lb-ft per radian

Run	Trim deg	Yaw deg	Cv	No. of Cycles	Roll Period seconds	Logarithmic Decrement	RMS Roll Fit deg	Added Inertia slug-ft.sq	Damping lb-ft/rps*
143	0	0	0.0	12.5	0.257	0.144	0.077	0.0053	0.0463
200	0	0	1.5	4.5	0.261	0.413	0.054	0.0064	0.1343
201	0	0	3.0	3.0	0.270	0.773	0.107	0.0089	0.2573
202	0	0	4.0	2.3	0.265	0.929	0.118	0.0070	0.3015
140	3	0	0.0	7.8	0.257	0.269	0.066	0.0052	0.0863
47	3	0	1.5	5.0	0.257	0.455	0.092	0.0051	0.1456
48	3	0	3.0	4.0	0.253	0.542	0.114	0.0038	0.1703
49	3	0	4.0	4.6	0.251	0.460	0.144	0.0032	0.1437
144	6	0	0.0	10.9	0.258	0.160	0.096	0.0056	0.0516
191	6	0	1.5	4.3	0.259	0.563	0.081	0.0056	0.1810
192	6	0	3.0	4.1	0.247	0.597	0.134	0.0018	0.1829
193	6	0	4.0	5.0	0.244	0.481	0.097	0.0010	0.1460
203	0	10	1.5	2.8	0.275	0.726	0.152	0.0107	0.2465
50	3	10	1.5	3.8	0.263	0.475	0.033	0.0070	0.1554
52	3	10	3.0	2.3	0.266	0.927	0.035	0.0073	0.3020
53	3	10	4.0	1.8	0.258	0.936	0.033	0.0047	0.2956
194	6	10	1.5	3.6	0.265	0.567	0.057	0.0076	0.1865
195	6	10	3.0	1.9	0.252	0.902	0.044	0.0029	0.2787
196	6	10	4.0	3.1	0.239	0.604	0.071	-0.0006	0.1790
204	0	15	1.5	2.1	0.286	0.958	0.112	0.0140	0.3351
89	3	15	1.5	2.3	0.276	0.564	0.028	0.0113	0.1932
90	3	15	3.0	1.0	0.284	1.492	0.025	0.0118	0.5019
197	6	15	1.5	3.5	0.266	0.582	0.060	0.0079	0.1921
198	6	15	3.0	2.8	0.262	0.772	0.058	0.0063	0.2493
199	6	15	4.0	2.6	0.239	0.756	0.084	-0.0008	0.2229

* rps = radians per second

TABLE 2.2

ROLL EXTINCTION RESULTS - 30 DEGREE DEADRISE

SPRING STIFFNESS 36.9 lb-ft per radian

Run	Trim deg	Yaw deg	Cv	No. of Cycles	Roll Period seconds	Logarithmic Decrement	RMS Roll Fit deg	Added Inertia slug-ft.sq	Damping lb-ft/rps*
134	0	0	0.0	13.3	0.205	0.167	0.184	0.0061	0.0686
127	0	0	1.5	6.4	0.209	0.347	0.102	0.0077	0.1451
128	0	0	3.0	3.5	0.212	0.670	0.079	0.0086	0.2818
129	0	0	4.0	2.5	0.215	0.793	0.109	0.0096	0.3367
139	3	0	0.0	14.0	0.203	0.129	0.152	0.0053	0.0525
94	3	0	1.5	6.8	0.207	0.349	0.062	0.0068	0.1445
95	3	0	3.0	5.8	0.206	0.449	0.062	0.0064	0.1846
96	3	0	4.0	4.0	0.202	0.551	0.064	0.0046	0.2216
136	6	0	0.0	19.3	0.203	0.092	0.121	0.0053	0.0375
110	6	0	1.5	7.8	0.206	0.295	0.097	0.0065	0.1216
111	6	0	3.0	3.9	0.198	0.543	0.072	0.0030	0.2141
112	6	0	4.0	5.3	0.189	0.456	0.065	-0.0004	0.1720
130	0	10	1.5	7.7	0.207	0.349	0.104	0.0068	0.1445
131	0	10	3.0	2.0	0.231	0.765	0.089	0.0167	0.3493
97	3	10	1.5	6.5	0.209	0.355	0.063	0.0077	0.1484
98	3	10	3.0	3.3	0.205	0.659	0.064	0.0057	0.2681
101	3	10	4.0	2.1	0.209	0.806	0.042	0.0071	0.3325
113	6	10	1.5	6.2	0.206	0.355	0.102	0.0064	0.1462
114	6	10	3.0	3.6	0.198	0.639	0.057	0.0029	0.2512
119	6	10	4.0	4.3	0.188	0.515	0.042	-0.0008	0.1929
132	0	15	1.5	3.4	0.213	0.540	0.108	0.0082	0.2296
102	3	15	1.5	5.3	0.212	0.421	0.065	0.0079	0.1787
121	6	15	1.5	5.3	0.209	0.448	0.051	0.0066	0.1874
123	6	15	3.0	3.5	0.203	0.655	0.053	0.0039	0.2645
124	6	15	4.0	3.2	0.189	0.589	0.049	-0.0015	0.2219

* rps = radians per second

TABLE 2.3

ROLL EXTINCTION RESULTS - 30 DEGREE DEADRISE

SPRING STIFFNESS 66.9 lb-ft per radian

Run	Trim deg	Yaw deg	Cv	No. of Cycles	Roll Period seconds	Logarithmic Decrement	RMS Roll Fit deg	Added Inertia slug-ft.sq	Damping lb-ft/rps*
147	0	0	0.0	7.3	0.161	0.304	0.149	0.0054	0.1722
149	0	0	0.0	9.9	0.154	0.189	0.172	0.0016	0.1025
148	0	0	0.0	7.5	0.161	0.308	0.161	0.0054	0.1744
167	0	0	1.5	4.7	0.161	0.456	0.127	0.0053	0.2575
168	0	0	3.0	3.3	0.161	0.662	0.086	0.0050	0.3717
169	0	0	4.0	3.0	0.162	0.807	0.091	0.0053	0.4535
175	3	0	0.0	12.7	0.161	0.123	0.131	0.0055	0.0698
176	3	0	1.5	6.9	0.163	0.380	0.111	0.0065	0.2176
177	3	0	3.0	2.6	0.163	0.432	0.047	0.0064	0.2471
179	3	0	4.0	4.8	0.161	0.432	0.061	0.0053	0.2441
178	3	0	4.0	4.8	0.161	0.422	0.063	0.0053	0.2385
150	6	0	0.0	13.4	0.160	0.106	0.092	0.0049	0.0598
155	6	0	1.5	9.0	0.162	0.267	0.125	0.0060	0.1522
156	6	0	3.0	7.0	0.156	0.324	0.088	0.0026	0.1777
157	6	0	4.0	7.3	0.153	0.266	0.070	0.0010	0.1432
170	0	10	1.5	4.4	0.165	0.468	0.071	0.0075	0.2708
171	0	10	3.0	3.0	0.178	0.618	0.086	0.0151	0.3842
180	3	10	1.5	6.7	0.166	0.320	0.108	0.0083	0.1868
181	3	10	3.0	3.5	0.165	0.555	0.053	0.0074	0.3204
182	3	10	4.0	2.4	0.160	0.806	0.066	0.0042	0.4473
158	6	10	1.5	5.9	0.162	0.327	0.053	0.0059	0.1863
159	6	10	3.0	4.4	0.155	0.457	0.054	0.0019	0.2484
160	6	10	4.0	6.0	0.150	0.352	0.049	-0.0007	0.1856
172	0	15	1.5	4.5	0.171	0.446	0.152	0.0093	0.2676
183	3	15	1.5	6.3	0.169	0.333	0.053	0.0082	0.1979
184	3	15	3.0	3.1	0.168	0.637	0.072	0.0073	0.3735
186	3	15	4.0	1.6	0.167	1.129	0.036	0.0056	0.6440
187	3	15	4.0	1.2	0.170	1.380	0.031	0.0066	0.7891
161	6	15	1.5	5.0	0.164	0.412	0.048	0.0052	0.2372
165	6	15	3.0	3.3	0.157	0.622	0.063	0.0010	0.3410
166	6	15	4.0	5.3	0.150	0.422	0.072	-0.0025	0.2222

* rps = radians per second

TABLE 2.4

ROLL EXTINCTION RESULTS - 30 DEGREE DEADRISE

SPRING STIFFNESS 89.7 lb-ft per radian

Run	Trim deg	Yaw deg	Cv	No. of Cycles	Roll Period seconds	Logarithmic Decrement	RMS Roll Fit deg	Added Inertia slug-ft.sq	Damping lb-ft/rps*
209	0	0	0.0	11.6	0.138	0.124	0.098	0.0086	0.0801
229	0	0	1.5	9.2	0.136	0.256	0.256	0.0072	0.1627
231	0	0	3.0	5.3	0.135	0.431	0.165	0.0065	0.2711
232	0	0	4.0	5.1	0.135	0.507	0.126	0.0064	0.3183
243	3	0	0.0	12.4	0.137	0.120	0.102	0.0079	0.0769
237	3	0	1.5	6.8	0.138	0.332	0.179	0.0084	0.2139
238	3	0	3.0	5.3	0.139	0.428	0.075	0.0090	0.2772
239	3	0	4.0	4.4	0.137	0.469	0.034	0.0077	0.2991
210	6	0	0.0	16.0	0.137	0.114	0.124	0.0079	0.0731
212	6	0	1.5	7.9	0.140	0.303	0.174	0.0098	0.1981
218	6	0	3.0	5.0	0.135	0.410	0.065	0.0065	0.2580
219	6	0	3.0	5.7	0.135	0.371	0.069	0.0065	0.2336
220	6	0	4.0	5.1	0.133	0.402	0.107	0.0052	0.2493
233	0	10	1.5	6.3	0.138	0.433	0.141	0.0074	0.2784
240	3	10	1.5	6.9	0.142	0.329	0.129	0.0101	0.2181
241	3	10	3.0	3.9	0.143	0.523	0.052	0.0105	0.3477
242	3	10	4.0	3.1	0.139	0.611	0.057	0.0078	0.3938
222	6	10	1.5	7.8	0.139	0.261	0.087	0.0081	0.1695
223	6	10	3.0	4.5	0.133	0.393	0.035	0.0042	0.2437
224	6	10	4.0	5.9	0.129	0.341	0.042	0.0018	0.2053
234	0	15	1.5	3.3	0.142	0.543	0.112	0.0098	0.3583
244	3	15	1.5	6.2	0.144	0.333	0.077	0.0114	0.2238
245	3	15	3.0	3.2	0.149	0.495	0.064	0.0146	0.3431
246	3	15	4.0	2.2	0.143	0.808	0.051	0.0101	0.5321
225	6	15	1.5	6.0	0.139	0.317	0.046	0.0081	0.2057
226	6	15	3.0	4.1	0.134	0.533	0.050	0.0047	0.3319
228	6	15	4.0	5.6	0.129	0.372	0.042	0.0018	0.2238

* rps = radians per second

TABLE 3

ADDED INERTIA AT 30 DEGREES DEADRISE

----- ADDED INERTIA IN ROLL, slug-ft.sq -----

Yaw Trim		Cv	Spring Stiffness, lb-ft/rad				Average	Formula	Mean Wetted Length, in
deg	deg		22.0	36.9	66.9	89.7			
0	0	0.0	0.0053	0.0061	0.0054	0.0086	0.0054	0.0120	46.0
0	0	0.0	-	-	0.0016	-	0.0054	0.0120	46.0
0	0	0.0	-	-	0.0054	-	0.0054	0.0120	46.0
0	0	1.5	0.0064	0.0077	0.0053	0.0072	0.0066	0.0121	46.3
0	0	3.0	0.0089	0.0086	0.0050	0.0065	0.0072	0.0120	46.0
0	0	4.0	0.0070	0.0096	0.0053	0.0064	0.0071	0.0120	46.0
0	3	0.0	0.0052	0.0053	0.0055	0.0079	0.0060	0.0095	36.5
0	3	1.5	0.0051	0.0068	0.0065	0.0084	0.0067	0.0093	35.7
0	3	3.0	0.0038	0.0064	0.0064	0.0090	0.0064	0.0082	31.2
0	3	4.0	0.0032	0.0046	0.0053	0.0077	0.0052	0.0071	27.2
0	3	4.0	-	-	0.0053	-	0.0052	0.0071	27.2
0	6	0.0	0.0056	0.0053	0.0049	0.0079	0.0059	0.0077	29.6
0	6	1.5	0.0056	0.0065	0.0060	0.0098	0.0070	0.0083	31.6
0	6	3.0	0.0018	0.0030	0.0026	0.0065	0.0041	0.0051	19.5
0	6	3.0	-	-	-	0.0065	0.0041	0.0051	19.5
0	6	4.0	0.0010	-0.0004	0.0010	0.0052	0.0017	0.0032	12.4
10	0	1.5	0.0107	0.0068	0.0075	0.0074	0.0081	0.0123	47.0
10	0	3.0	-	0.0167	0.0151	-	0.0159	0.0123	47.0
10	3	1.5	0.0070	0.0077	0.0083	0.0101	0.0083	0.0087	33.3
10	3	3.0	0.0073	0.0057	0.0074	0.0105	0.0077	0.0086	33.1
10	3	4.0	0.0047	0.0071	0.0042	0.0078	0.0060	0.0077	29.6
10	6	1.5	0.0076	0.0064	0.0059	0.0081	0.0070	0.0078	30.0
10	6	3.0	0.0029	0.0029	0.0019	0.0042	0.0030	0.0053	20.2
10	6	4.0	-0.0006	-0.0008	-0.0007	0.0018	-0.0000	0.0033	12.6
15	0	1.5	0.0140	0.0082	0.0093	0.0098	0.0103	0.0123	47.0
15	3	1.5	0.0113	0.0079	0.0082	0.0114	0.0097	0.0094	36.0
15	3	3.0	0.0118	-	0.0073	0.0146	0.0112	0.0098	37.4
15	3	4.0	-	-	0.0056	0.0101	0.0074	0.0088	33.5
15	3	4.0	-	-	0.0066	-	0.0074	0.0088	33.5
15	6	1.5	0.0079	0.0066	0.0052	0.0081	0.0070	0.0077	29.4
15	6	3.0	0.0063	0.0039	0.0010	0.0047	0.0040	0.0052	20.0
15	6	4.0	-0.0008	-0.0015	-0.0025	0.0018	-0.0007	0.0034	13.0

TABLE 4

ROLL DAMPING AT 30 DEGREES DEADRISE

-----ROLL DAMPING, lb-ft/radians per second-----

Yaw Trim		Cv	Spring Stiffness, lb-ft/rad					Average	Formula	Mean Wetted Length, in
deg	deg		22.0	36.9	66.9	89.7				
0	0	0.0	0.0463	0.0686	0.1722	0.0801	0.1074	0.1526	46.0	
0	0	0.0	-	-	0.1025	-	0.1074	0.1526	46.0	
0	0	0.0	-	-	0.1744	-	0.1074	0.1526	46.0	
0	0	1.5	0.1343	0.1451	0.2575	0.1627	0.1749	0.2192	46.3	
0	0	3.0	0.2573	0.2818	0.3717	0.2711	0.2954	0.2837	46.0	
0	0	4.0	0.3015	0.3367	0.4535	0.3183	0.3525	0.3274	46.0	
0	3	0.0	0.0863	0.0525	0.0698	0.0769	0.0714	0.1211	36.5	
0	3	1.5	0.1456	0.1445	0.2176	0.2139	0.1804	0.1840	35.7	
0	3	3.0	0.1703	0.1846	0.2471	0.2772	0.2198	0.2346	31.2	
0	3	4.0	0.1437	0.2216	0.2441	0.2991	0.2294	0.2650	27.2	
0	3	4.0	-	-	0.2385	-	0.2294	0.2650	27.2	
0	6	0.0	0.0516	0.0375	0.0598	0.0731	0.0555	0.0982	29.6	
0	6	1.5	0.1810	0.1216	0.1522	0.1981	0.1633	0.1704	31.6	
0	6	3.0	0.1829	0.2141	0.1777	0.2133	0.2666	0.1958	19.5	
0	6	3.0	-	-	-	0.2133	0.2666	0.1958	19.5	
0	6	4.0	0.1460	0.1720	0.1432	0.2493	0.1776	0.2159	12.4	
10	0	1.5	0.2465	0.1445	0.2708	0.2784	0.2350	0.2565	47.0	
10	0	3.0	-	0.3493	0.3842	-	0.3667	0.3220	47.0	
10	3	1.5	0.1554	0.1484	0.1868	0.2181	0.1772	0.2110	33.3	
10	3	3.0	0.3020	0.2681	0.3204	0.3477	0.3095	0.2759	33.1	
10	3	4.0	0.2956	0.3325	0.4473	0.3938	0.3673	0.3080	29.6	
10	6	1.5	0.1865	0.1462	0.1863	0.1695	0.1721	0.2001	30.0	
10	6	3.0	0.2787	0.2512	0.2484	0.2437	0.2555	0.2331	20.2	
10	6	4.0	0.1790	0.1929	0.1856	0.2053	0.1907	0.2516	12.6	
15	0	1.5	0.3351	0.2296	0.2676	0.3583	0.2976	0.2736	47.0	
15	3	1.5	0.1932	0.1787	0.1979	0.2238	0.1984	0.2371	36.0	
15	3	3.0	0.5019	-	0.3735	0.3431	0.4062	0.3073	37.4	
15	3	4.0	-	-	0.6440	0.5321	0.6551	0.3381	33.5	
15	3	4.0	-	-	0.7891	-	0.6551	0.3381	33.5	
15	6	1.5	0.1921	0.1874	0.2372	0.2057	0.2056	0.2152	29.4	
15	6	3.0	0.2493	0.2645	0.3410	0.3319	0.2967	0.2496	20.0	
15	6	4.0	0.2229	0.2219	0.2222	0.2238	0.2227	0.2700	13.0	

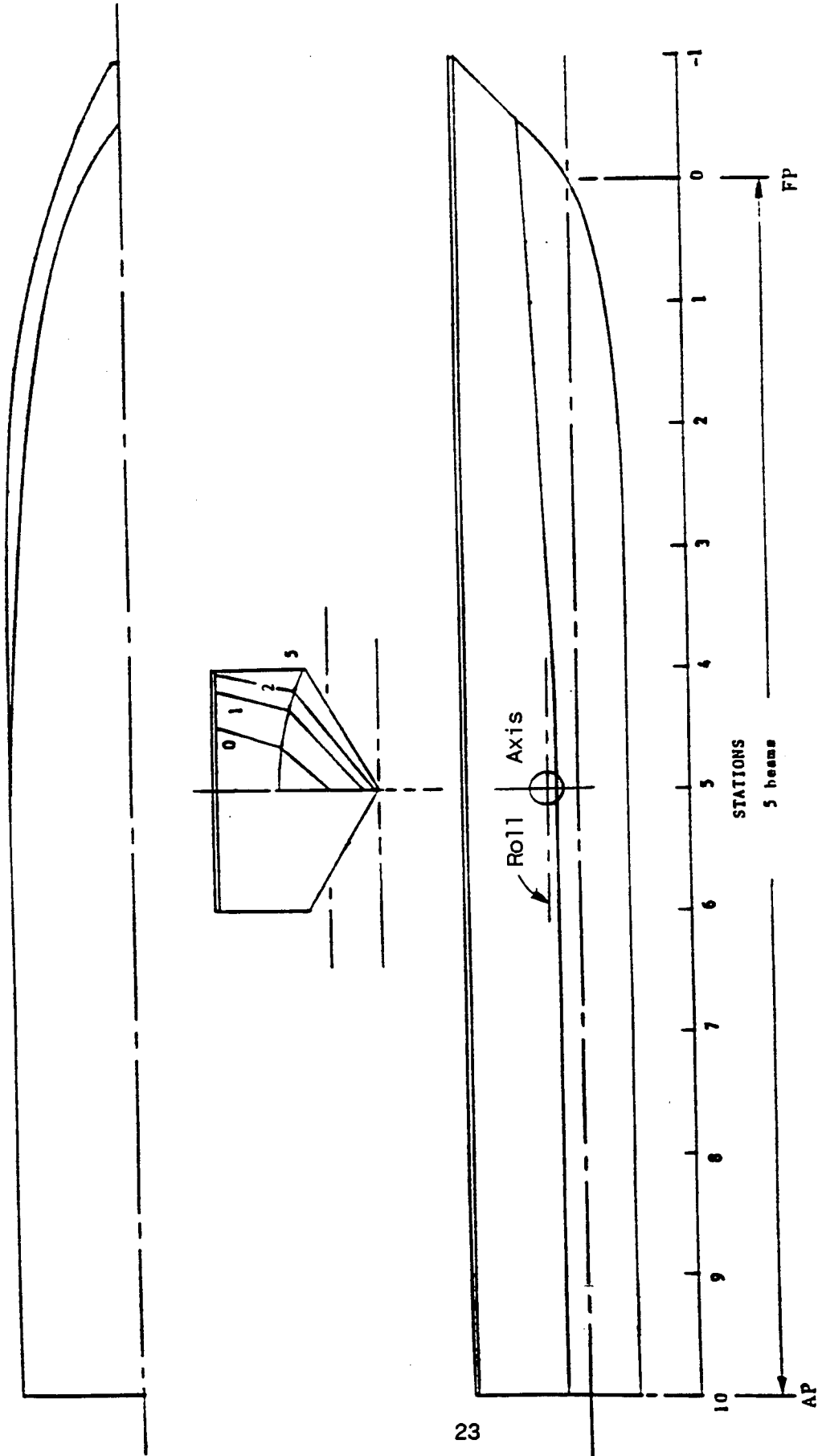

FIGURE 1 LINES OF 30° DEADRISE MODEL

R-2661

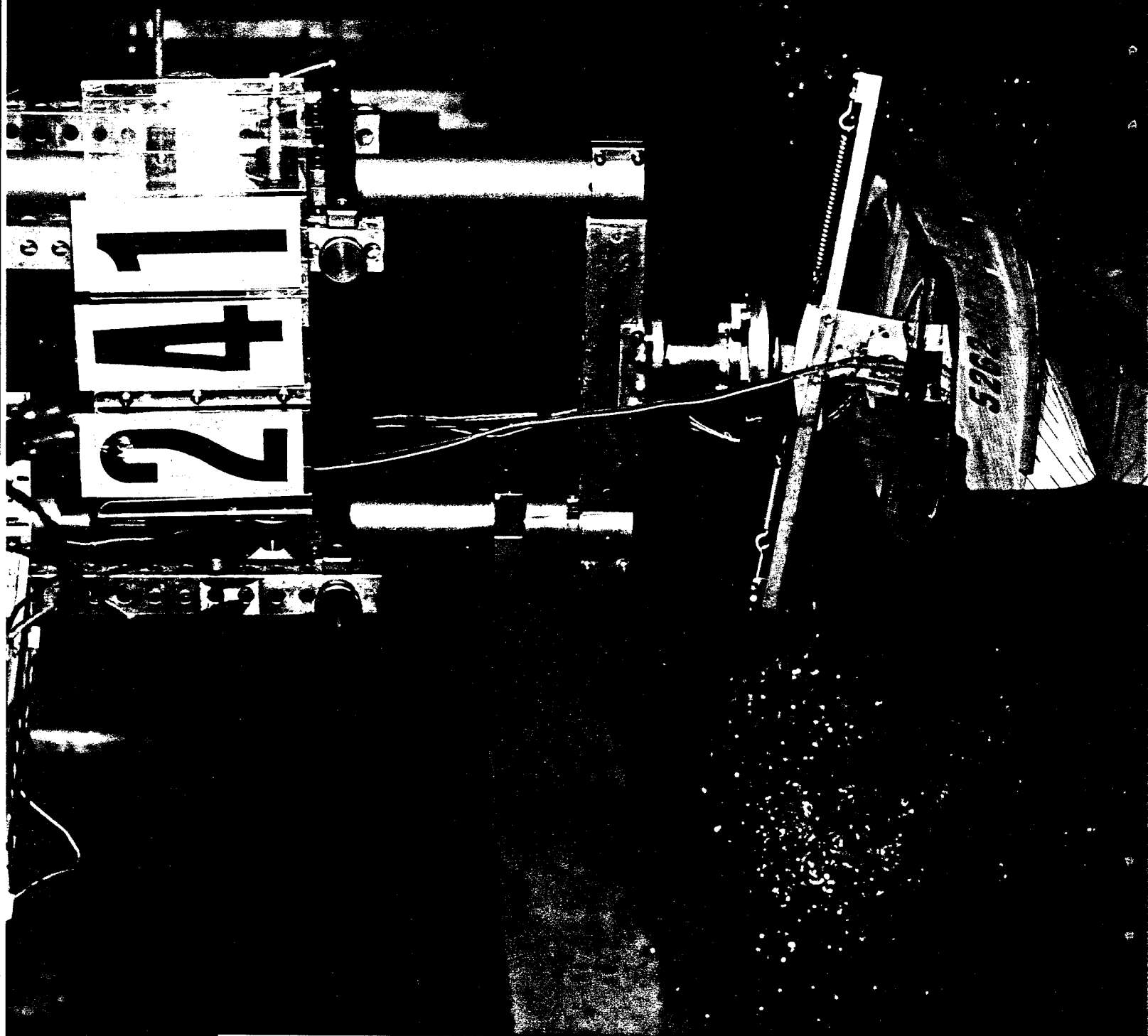

FIGURE 2 MODEL IN ROLL APPARATUS PRIOR TO RELEASE

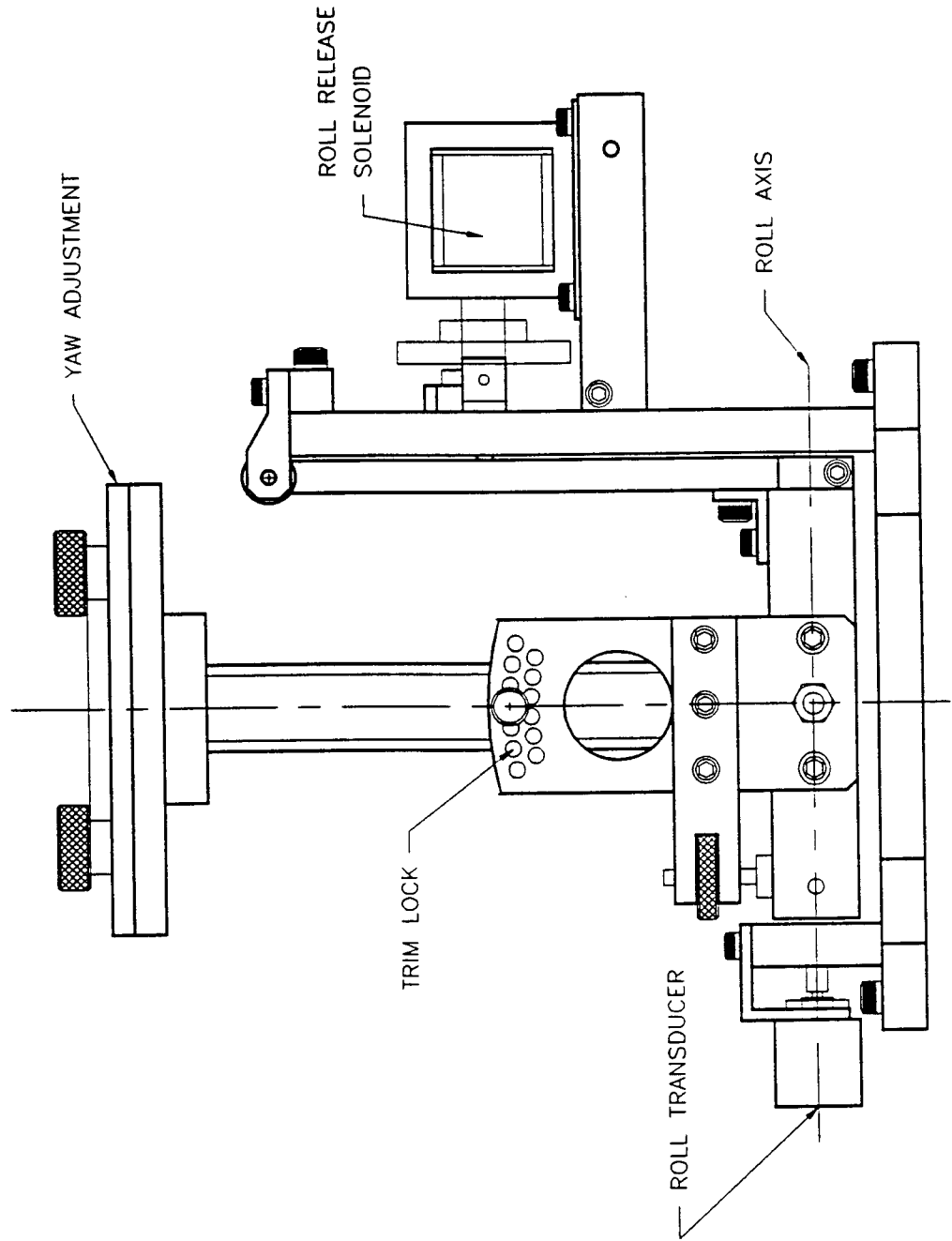

FIGURE 3 SIDE VIEW OF ROLL OSCILLATION APPARATUS

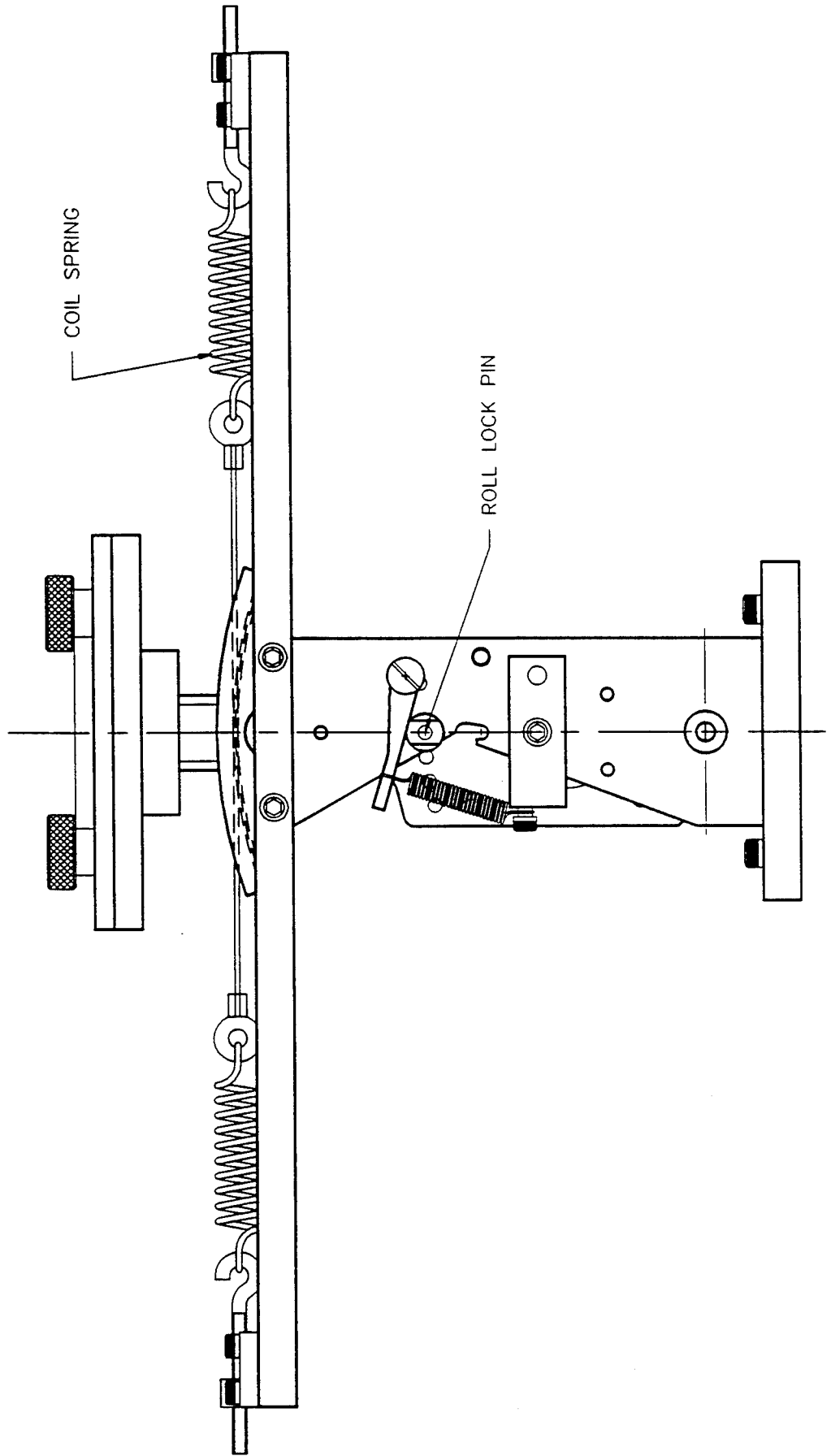

FIGURE 4 END VIEW OF ROLL OSCILLATION APPARATUS

R-2661



FIGURE 5 INSTALLATION OF ROLL APPARATUS IN MODEL

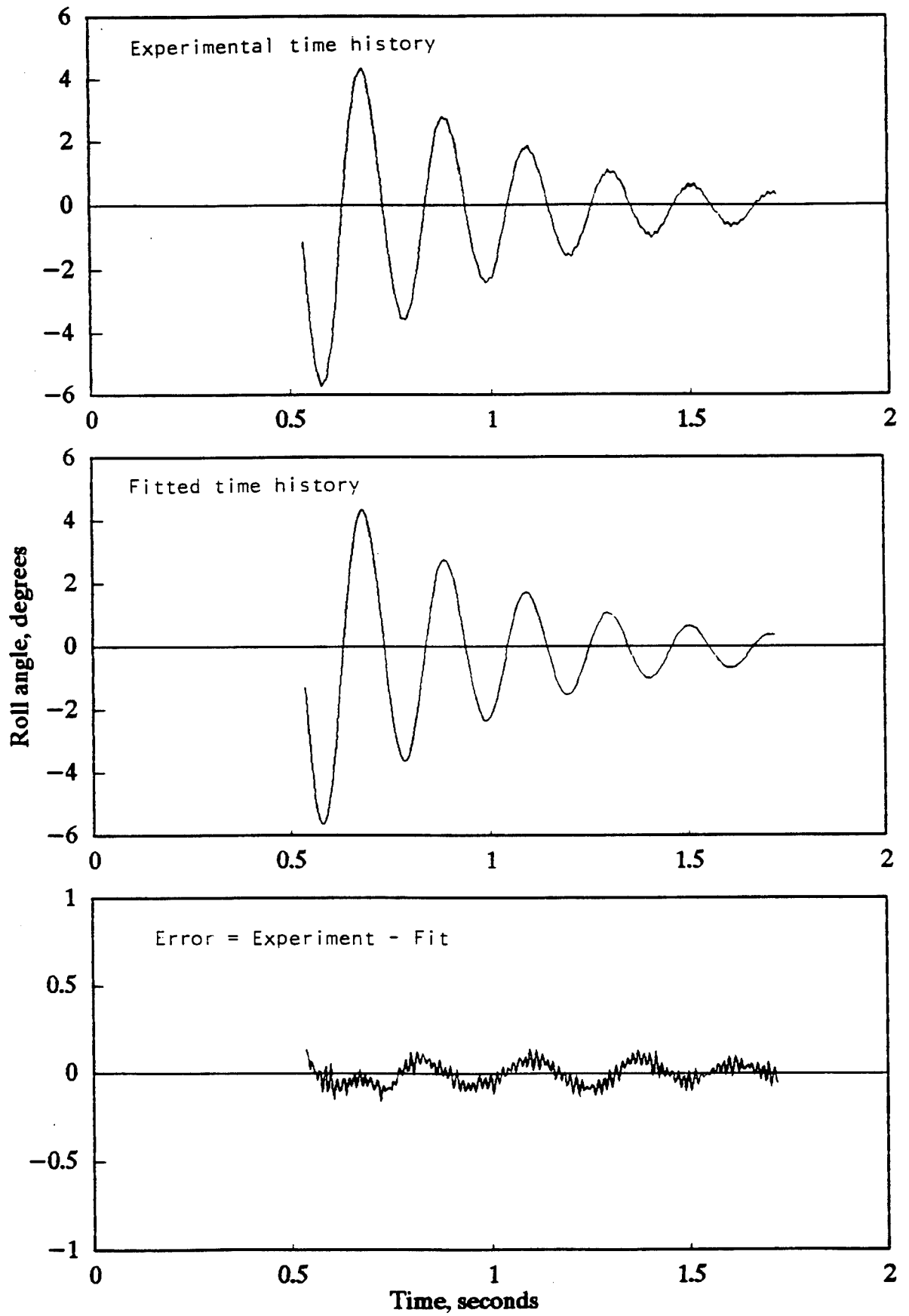

FIGURE 6 COMPARISON OF OBSERVED AND FITTED TIME HISTORY FOR RUN 95

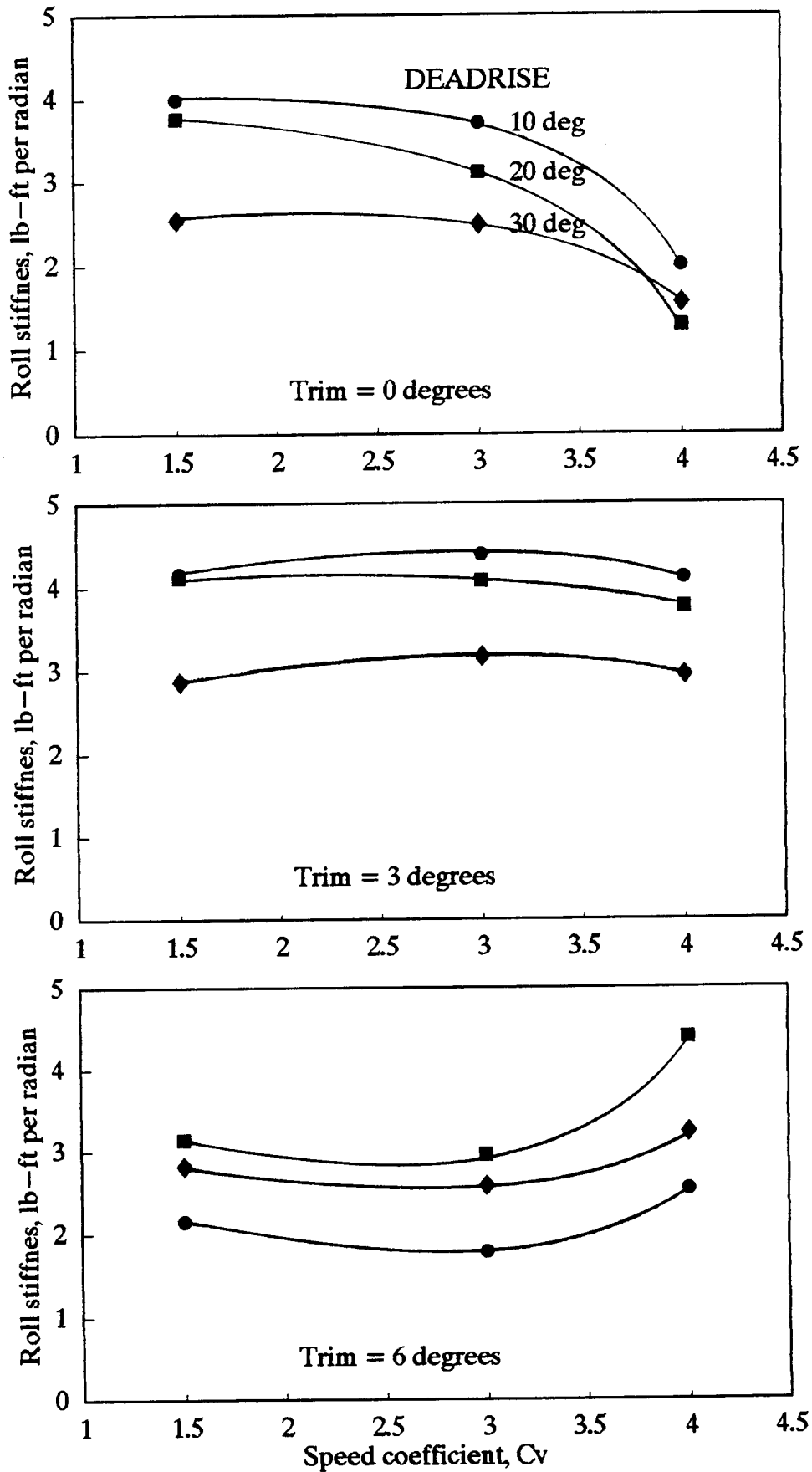

FIGURE 7 VARIATION OF ROLL STIFFNESS WITH SPEED AT ZERO YAW

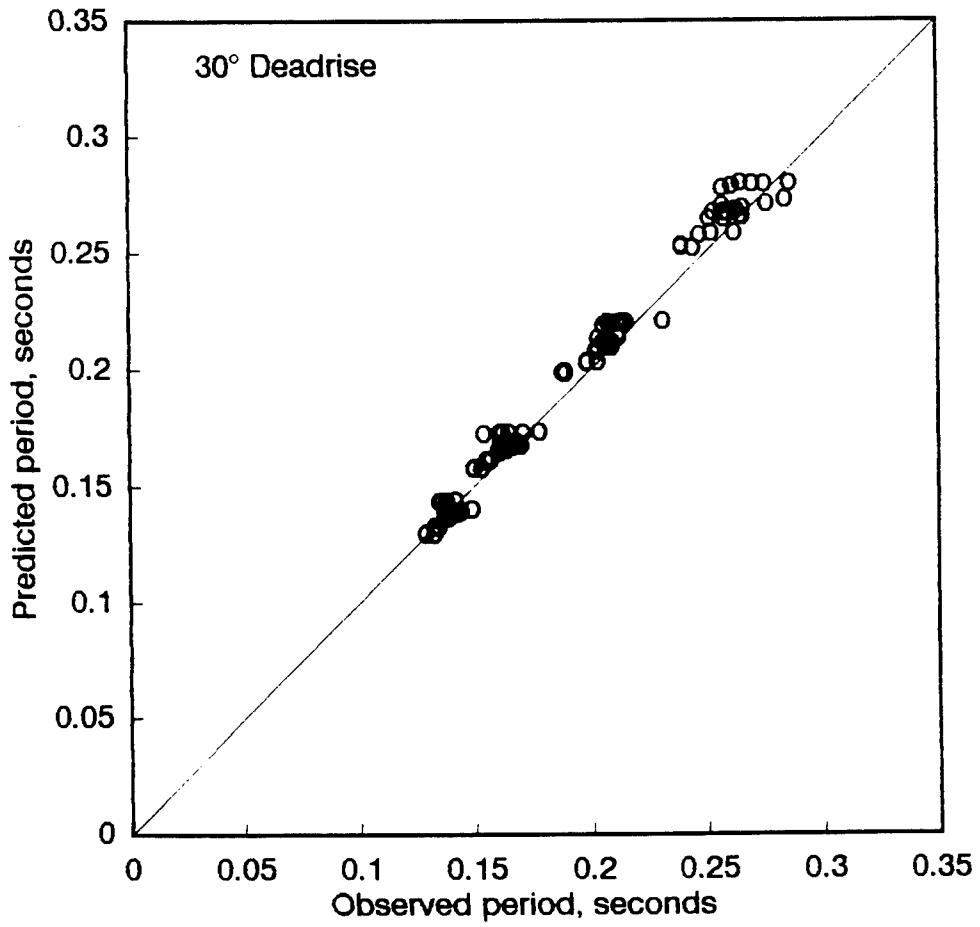

FIGURE 8 COMPARISON OF OBSERVED AND PREDICTED PERIODS

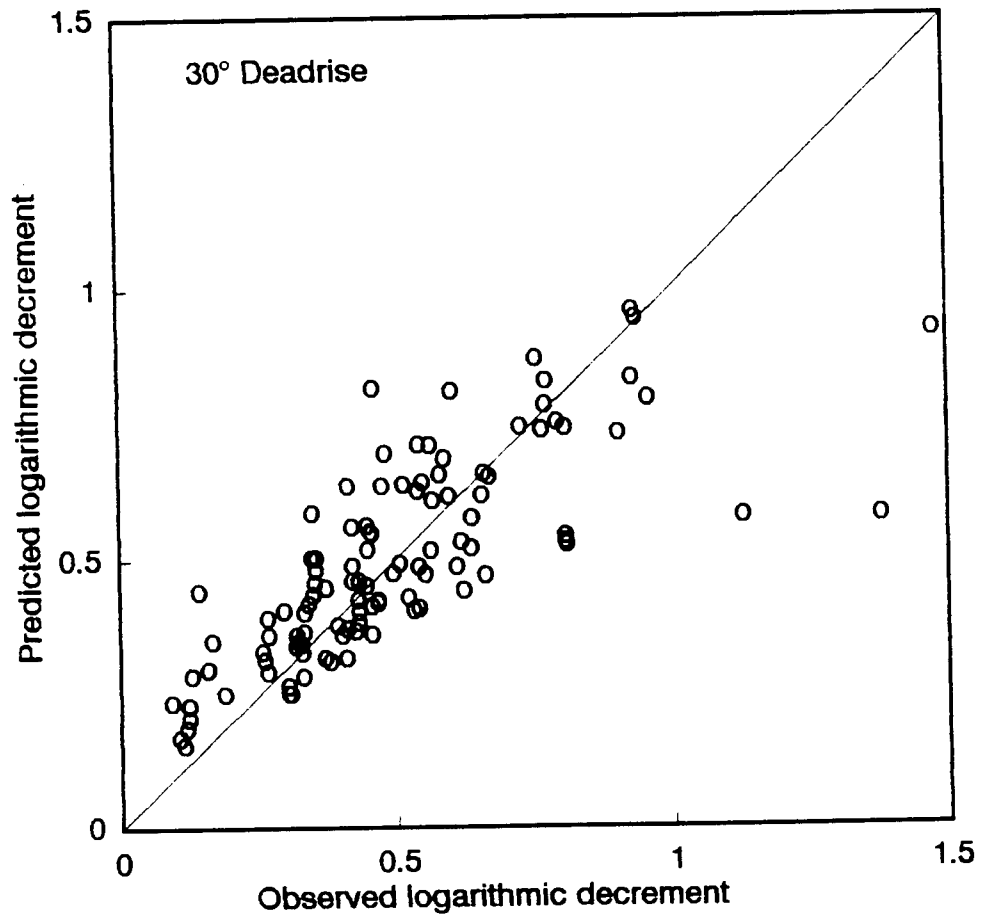

FIGURE 9 COMPARISON OF OBSERVED AND PREDICTED DECREMENTS