

NAVY EXPERIMENTAL DIVING UNIT

REPORT NO. 2-95

ELIMINATING CHATTER IN THE MK 24 FULL FACE  
MASK BY ADJUSTING DEMAND LEVER FREE PLAY  
AND INHALATION CRACKING PRESSURE

LT CREPEAU

FEBRUARY, 1995

## NAVY EXPERIMENTAL DIVING UNIT

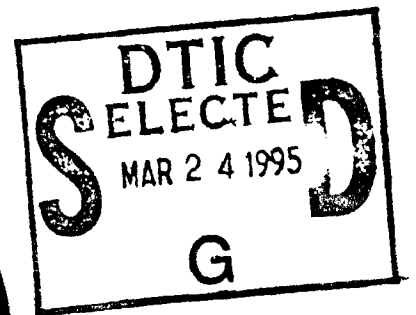
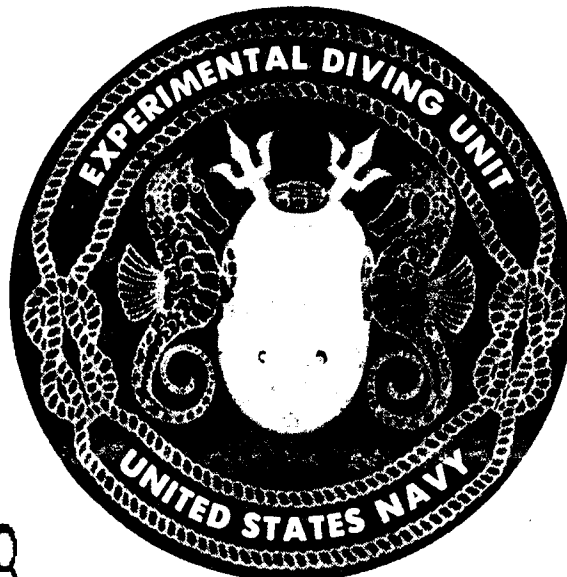

19950322 078

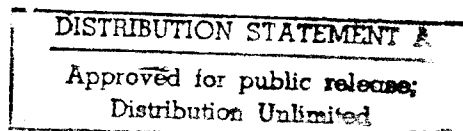



DEPARTMENT OF THE NAVY  
 NAVY EXPERIMENTAL DIVING UNIT  
 PANAMA CITY, FLORIDA 32407-5001

IN REPLY REFER TO:  
 TA94-025

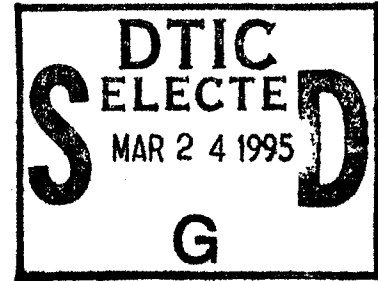

NAVY EXPERIMENTAL DIVING UNIT

REPORT NO. 2-95

ELIMINATING CHATTER IN THE MK 24 FULL FACE  
 MASK BY ADJUSTING DEMAND LEVER FREE PLAY  
 AND INHALATION CRACKING PRESSURE

LT CREPEAU

FEBRUARY, 1995

DISTRIBUTION STATEMENT A: Approved for public release; distribution is unlimited.

Submitted:

*[Signature]*  
 L. J. CREPEAU  
 LT, USN  
 Research Psychologist

Reviewed:

*[Signature]*  
 J. A. MOREL  
 BUCS, USN  
 Special Warfare

Approved:

*[Signature]*  
 BERT MARSH  
 CDR, USN  
 Commanding Officer  
 Projects Officer

*[Signature]*  
 M. E. KNAFELC  
 CAPT (Sel), MC, USN  
 Senior Medical Officer

*[Signature]*  
 B. D. MCKINLEY  
 LCDR, USN  
 Senior Projects Officer

*[Signature]*  
 J. R. CLARKE, PhD  
 Scientific Director

*[Signature]*  
 J. C. NELSON  
 LCDR, USN  
 Executive Officer

Accession For	
NTIS CRA&I	<input checked="" type="checkbox"/>
DTIC TAB	<input type="checkbox"/>
Unannounced	<input type="checkbox"/>
Justification	
By	
Distribution /	
Availability Codes	
Dist	Avail and/or Special
A-1	

REPORT DOCUMENTATION PAGE			
1a. REPORT SECURITY CLASSIFICATION UNCLASSIFIED		1b. RESTRICTIVE MARKINGS	
2a. SECURITY CLASSIFICATION AUTHORITY		3. DISTRIBUTION/AVAILABILITY OF REPORT	
2b. DECLASSIFICATION/DOWNGRADING SCHEDULE		DISTRIBUTION STATEMENT A: Approved for public release; distribution is unlimited.	
4. PERFORMING ORGANIZATION REPORT NUMBER(S) NEDU TECHNICAL REPORT NO. 2-95		5. MONITORING ORGANIZATION REPORT NUMBER(S)	
6a. NAME OF PERFORMING ORGANIZATION NAVY EXPERIMENTAL DIVING UNIT	6b. OFFICE SYMBOL (If applicable) 02	7a. NAME OF MONITORING ORGANIZATION	
6c. ADDRESS(City, State, and ZIP Code) 321 Bullfinch Road, Panama City, FL 32407-7015		7b. ADDRESS(City, State, and ZIP Code)	
8a. NAME OF FUNDING SPONSORING ORGANIZATION NAVAL SEA SYSTEMS COMMAND	8b. OFFICE SYMBOL (If applicable) OOC	9. PROCUREMENT INSTRUMENT IDENTIFICATION NUMBER	
8c. ADDRESS (City, State, and ZIP Code) 2531 Jefferson Davis Highway, Arlington, VA 22242-5160		10. SOURCE OF FUNDING NUMBERS	
		PROGRAM ELEMENT NO.	PROJECT NO.
		TASK NO. 94-025	WORK UNIT ACCESSION NO.
11. TITLE (Include Security Classification) ELIMINATING CHATTER IN THE MK 24 FULL FACE MASK BY ADJUSTING DEMAND LEVER FREE PLAY AND INHALATION CRACKING PRESSURE			
12. PERSONAL AUTHOR(S) LORING J. CREPEAU			
a. TYPE OF REPORT TECHNICAL REPORT	b. TIME COVERED FROM NOV 94 TO JAN 95	14. DATE OF REPORT (Year,Month,Day) FEBRUARY 1995	15. PAGE COUNT 25
16. SUPPLEMENTARY NOTATION			
17. COSATI CODES			18. SUBJECT TERMS (Continue on reverse if necessary and identify by block number)  Full Face Mask (FFM); MK 24 FFM; MK 16 Underwater Breathing Apparatus (UBA); Open-Circuit Mode; Inhalation Chatter, Overbottom Pressure, Inhalation Cracking Pressure; EOD decompression; SDV transit
FIELD	GROUP	SUB-GROUP	
19. ABSTRACT (Continue on reverse if necessary and identify by block number)  The MK 24 full face mask (FFM) is configured to support MK 16 MOD 0 UBA decompression dives and SEAL delivery vehicle (SDV) transits. During certification testing at depths shallower than 15.3 msw (50 fsw) the FFM produced chatter upon inhalation in the open circuit mode, apparently due to newly-designed second stage regulator poppet valves and demand levers.			
20. DISTRIBUTION/AVAILABILITY OF ABSTRACT <input type="checkbox"/> UNCLASSIFIED/UNLIMITED <input checked="" type="checkbox"/> SAME AS RPT. <input type="checkbox"/> DTIC USERS		21. ABSTRACT SECURITY CLASSIFICATION Unclassified	
22a. NAME OF RESPONSIBLE INDIVIDUAL NEDU Librarian	22b. TELEPHONE(Include Area Code) 904-230-3100	22c. OFFICE SYMBOL	

19. ABSTRACT (Continued)

Reducing overbottom (O/B) pressure from 931 kPa (135 psi) to 793 kPa (115 psi) reportedly eliminated chatter during certification testing, although this strategy's influence on breathing performance was not determined. The MK 24 FFM is designed for use in the open circuit mode by a diver primarily at rest, but also needs to support a diver if confronted by an emergency requiring vigorous exercise to remedy.

We tested MK 24 regulators equipped with new second stage poppets and demand levers. In the first series of studies we tested four different FFM configurations, using surface-supplied air during the first three, and a SCUBA tank during the fourth: 1) 793 kPa O/B; 2) 931 kPa O/B with an inlet air diffuser designed to reduce chatter; 3) 931 kPa O/B without the diffuser; and 4) 931 kPa O/B without the diffuser. During the second series we determined how high cracking pressure needed to be to eliminate chatter.

Reducing O/B pressure and installing the diffuser both failed to eliminate chatter, whereas adjusting the free play in the demand lever between 1.59 and 3.18 mm (.0625 and .125 in) and adjusting inhalation cracking pressure between 872 and 996 Pa (3.5 and 4.0 in H<sub>2</sub>O) completely eliminated chatter. While this increased peak inhalation pressure, it did not increase the divers' subjective perception of respiratory effort. During the second series of tests the average cracking pressure [ $\pm$  95% confidence interval] needed to eliminate chatter was  $575.4 \pm 60.5$  Pa ( $2.31 \pm .24$  in H<sub>2</sub>O).

NEDU recommends adjusting demand lever free play between 1.59 and 3.18 mm (.0625 and .125 in), and cracking pressure at  $747 \pm 249$  Pa ( $3 \pm 1$  in H<sub>2</sub>O) to eliminate chatter in the MK 24 FFM. Additionally, NEDU cautions against diving the MK 24 FFM open circuit in the swimming mode, as its ability to provide gas to a continuously working diver has not been characterized.

## CONTENTS

	<u>Page No.</u>
INTRODUCTION	1
METHODS	1
RESULTS	4
DISCUSSION	7
CONCLUSIONS / RECOMMENDATIONS	8
REFERENCES	9
APPENDIX A - MK 24 FFM Performance Evaluation Questionnaire	A-1
APPENDIX B - Raw Data From Series 1, Phase 1 Testing	B-1 to B-3
APPENDIX C - Raw Data From Series 1, Phase 2 Testing	C-1 to C-3
APPENDIX D - Raw Data From Series 1, Phase 3 Testing	D-1 to D-6
APPENDIX E - Raw Data From Series 1, Phase 4 Testing	E-1
APPENDIX F - Raw Data From Series 2 Testing	F-1
APPENDIX G - Draft Maintenance Requirement Card For MK 24 FFM Open Circuit Regulator	G-1 to G-5

## ILLUSTRATIONS

<u>Figure No.</u>		<u>Page No.</u>
1	Phase 1 subjective ratings of chatter severity	4
2	Phase 1 subjective ratings of breathing resistance and confidence using the FFM during an emergency	4
3	Phase 2 subjective ratings of chatter severity	5
4	Phase 2 subjective ratings of breathing resistance and confidence using the FFM during an emergency	5
5	Peak inhalation pressure obtained at each work level during the first three phases of testing	6
6	Phase 3 subjective ratings of breathing resistance and confidence using the FFM during an emergency	6
7	Phase 4 subjective ratings of breathing resistance and confidence using the FFM during an emergency	7

## TABLES

<u>Table No.</u>		<u>Page No.</u>
1	Test Conditions for Measuring Work of Breathing	2

## INTRODUCTION

The MK 24 is a full face mask (FFM) configured to support MK 16 MOD 0 UBA decompression dives and transits in SEAL delivery vehicles (SDVs). The MK 24 is equipped with a switchover block that allows divers to alternate between an open circuit Scubapro® regulator and a closed circuit MK 16 underwater breathing apparatus (UBA) without removing the mask.

The original evaluation<sup>1</sup> reported that the MK 24 FFM provided adequate open and closed circuit breathing performance and possessed a favorable human factors evaluation. However, during certification testing recently conducted in Key West, FL the FFM produced chatter in the open circuit mode. In follow-up unmanned testing at NEDU the chatter appeared to be caused when newly-designed second stage regulator poppet valves and demand levers were substituted by Scubapro for the originals. The chatter was characterized by 15-20 Hz pressure oscillations during inhalation, and typically occurred at depths shallower than 15.3 msw (50 fsw).

Seeking an on-site resolution to this problem the Key West divers reduced overbottom (O/B) pressure from 931 kPa (135 psi) to 793 kPa (115 psi), thereby eliminating chatter. However, they could not document whether or not reducing the overbottom pressure restricted gas flow during work in the open circuit mode.

Though the FFM in the open circuit mode was designed for use with the diver primarily at rest, prudence dictates that the regulator should be able to deliver adequate breathing gas during short periods of increased work, e.g., during an emergency. NEDU was tasked<sup>2</sup> to characterize how reducing O/B pressure from 931 kPa to 793 kPa affects FFM open-circuit regulator performance.

We conducted two series of tests. During the first series we focused on two issues. First, whether reducing the O/B pressure eliminates chatter. Second, whether it degrades the FFM's breathing performance during work. The second concern applies to FFM performance during an emergency, when providing adequate ventilation to a vigorously exercising diver is crucial. During the second series we focused on how high inhalation cracking pressure needs to be while using 931 kPa O/B pressure to effectively eliminate chatter.

## METHODS

We conducted both series of manned tests<sup>3,4</sup> in the 4.6 meter (15 ft) deep NEDU Ocean Simulation Facility test pool heated between 24° and 31° C (75° to 88°F). We equipped the MK 24 FFMs with new second stage poppets and demand levers. Throughout testing we utilized air as the breathing medium. Before

Informed Consent Forms.

Series 1. During the first three phases the FFMs were fitted with 15.2 meter (50 foot) second stage whips utilizing air from the OSF bottle field and Nylaflow® sampling lines to monitor differential pressure ( $\Delta P$ ) and end tidal carbon dioxide ( $P_{etCO_2}$ ); during Phase 4 they were set up with a Conshelf XIV® first stage regulator and a SCUBA tank. Pedal ergometers (Warren E. Collins, Braintree, MA) were used to impose work demands on the divers during the first three test phases.

We tested the MK 24 regulator in the four configurations shown in Table 1.

TABLE 1

TEST CONDITIONS EMPLOYED DURING THE FIRST SERIES OF MANNED TESTS

<u>Test Phase</u>	<u>Overbottom Pressure</u> (kPa / PSI)	<u>Diffuser Installed?</u> (YES / NO)	<u>Exercise Regimen?</u> (YES / NO)	<u>Number of Dives</u>
1	793 / 115	NO	YES	10
2	931 / 135	YES	YES	10
3	931 / 135	NO	YES	26
4	931 / 135-SCUBA	NO	NO	10

We set the FFMs up per the maintenance requirement card (MRC)<sup>5</sup> throughout Phase 1 and the initial Phase 2 dives. After encountering continued chatter during Phase 1, we measured the cracking pressure of the FFMs and found it to be approximately 249 Pa (1.0 in H<sub>2</sub>O). In an effort to reduced chatter during Phase 2, we first ensured that the demand lever free play was between 1.59 and 3.18 mm (.0625 and .125 in) per the MRC<sup>5</sup> in one FFM following the first dive. When chatter persisted, we adjusted demand lever free play in the second regulator. When we still encountered chatter, the Coastal Systems Station engineers suggested increasing cracking pressure, so we increased it in both FFMs to between 872 and 996 Pa (3.5 and 4.0 in H<sub>2</sub>O). These settings were used throughout subsequent testing.

Divers entered the water and mounted the pedal ergometers. At that time, they responded to a questionnaire (Appendix A) to provide a baseline rating of chatter and dyspnea. They then began the work phase of testing shown below while their breathing performance was continuously monitored:

**50 watts (3 min) > 100 watts (3 min) > 150 watts (3 min) >  
50 watt cool down (3 min)**



The divers pedaled continuously at  $60 \pm 5$  RPM during all exercise stages. During the last 30 seconds of each exercise stage,  $\Delta P$  and  $P_{a}CO_2$  were sampled and logged. After completing each stage, the divers responded to the questionnaire. All but two divers followed this work schedule. Those two divers became fatigued before we imposed higher work levels. This did not compromise the test, since our goal was only to increase each diver's ventilatory rate from rest to near maximum.

During the Phase 4, a diver was deployed with the instruction to swim about the test pool, but to avoid engaging in any strenuous physical activity. That diver also responded to the questionnaire after surfacing.

Series 2. The FFMs were fitted with 15.2 meter (50 foot) second stage whips utilizing air from the OSF bottle field. The O/B pressure was set to 931 kPa and cracking pressure was set to 249 Pa (1 in H<sub>2</sub>O). Divers entered the water and descended to the bottom. Before mounting the ergometers, each diver tightened the other's cracking pressure adjustment plug using one quarter turn increments until chatter was eliminated. The divers mounted the ergometers with the workload set at 50 watts and, when directed, pedaled continuously for five minutes at  $60 \pm 5$  RPM to ensure chatter was not resurrected by higher breathing rates.

After surfacing, each diver reported how many turns were required to eliminate chatter in his partner's FFM. We measured each FFM's cracking pressure using a manometer, then adjusted it back down to 249 Pa before deploying the next set of divers.

## RESULTS

Series 1. Reducing O/B to 793 kPa did not eliminate chatter during Phase 1, as seen in Figure 1. All raw questionnaire data are provided in Appendix B.

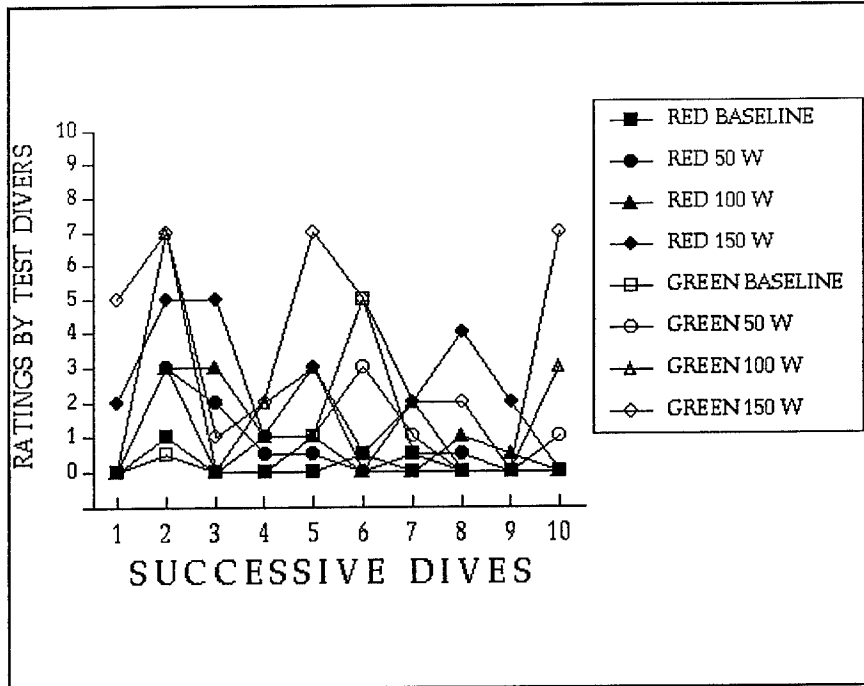

**Figure 1.** Phase 1 subjective ratings of chatter severity

At the same time, the divers still reported acceptable breathing resistance levels, and they expressed high confidence that they could use this rig during an emergency (Figure 2).

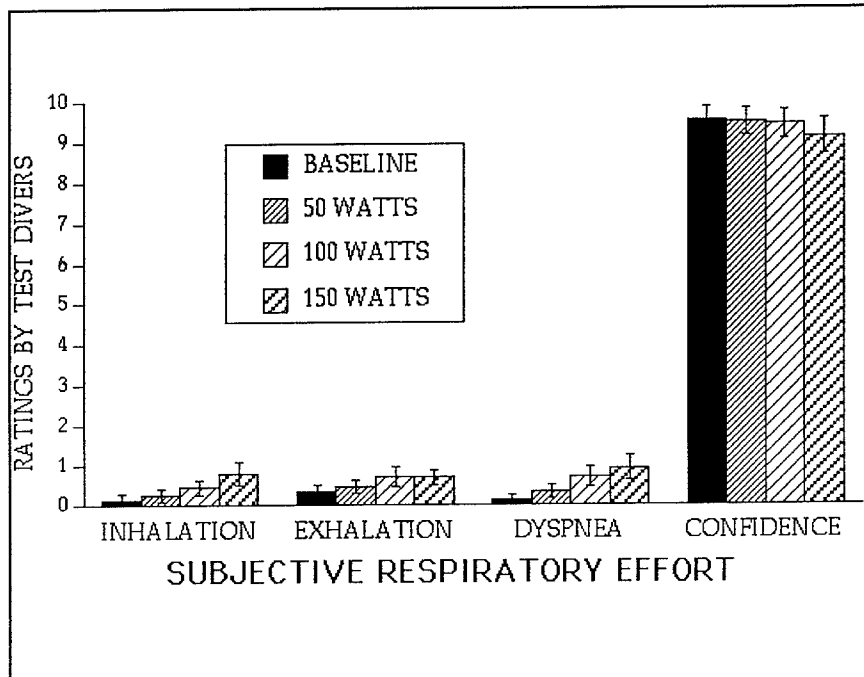

**Figure 2.** Phase 1 subjective ratings of breathing resistance and confidence using the FFM during an emergency

Figure 3 shows levels of chatter reported by divers during Phase 2 testing. The diffuser was ineffective in eliminating chatter while using 931 kPa O/B supply pressure. All raw questionnaire data are provided in Appendix C.

However, it is also clear from Figure 3 that we successfully eliminated chatter throughout the remainder of Phase 2 testing after adjusting the FFMs following the first three dives of that series.

Figure 4 clearly illustrates that this adjustment did not negatively affect subjective breathing resistance levels or the divers' confidence in the FFM during an emergency.

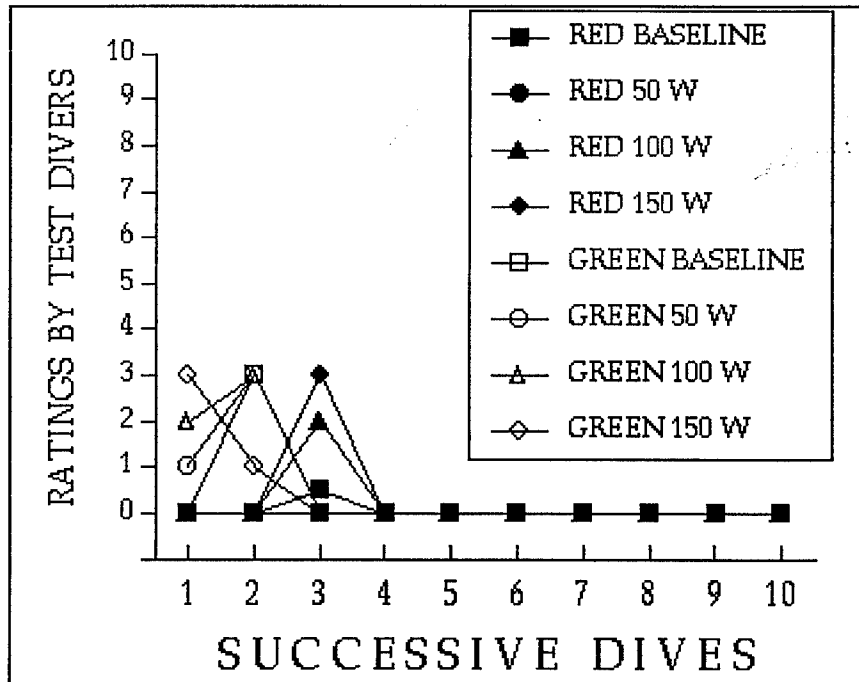

Figure 3. Phase 2 subjective ratings of chatter severity

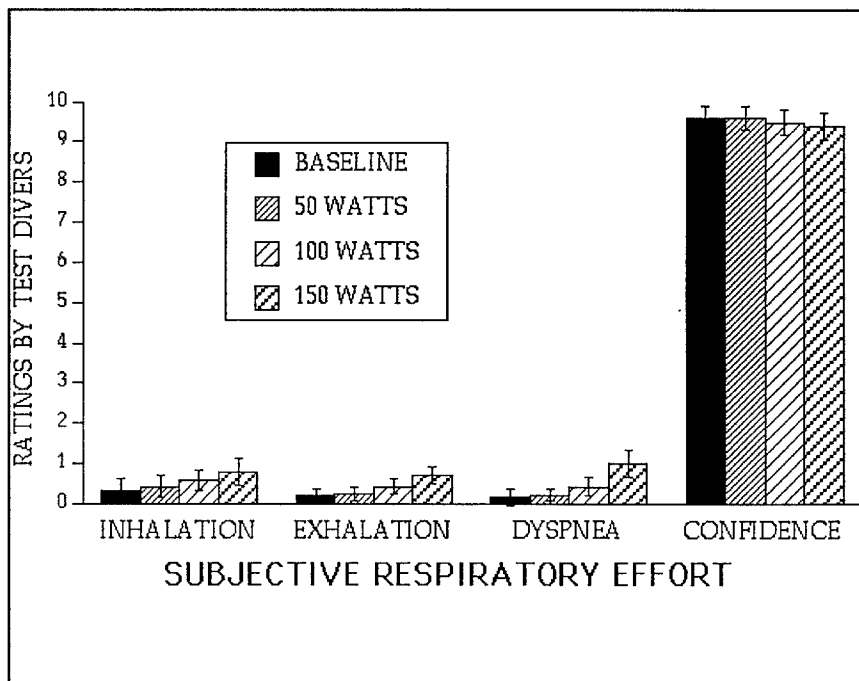
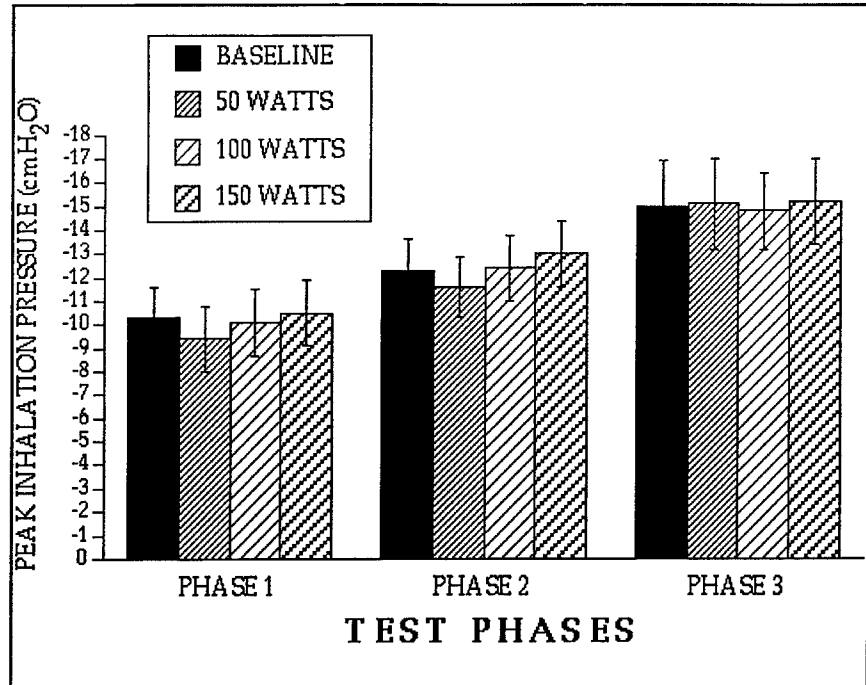
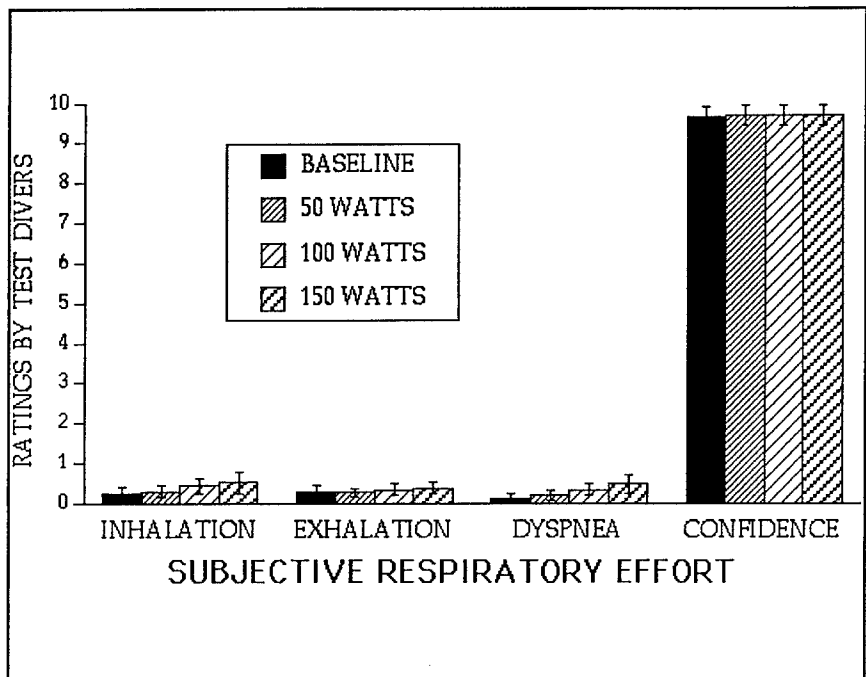

Figure 4. Phase 2 subjective ratings of breathing resistance and confidence using the FFM during an emergency

Chatter remained virtually absent throughout Phase 3 testing. While these adjustments increased peak inhalation pressure (Figure 5), subjective ratings of breathing resistance remained low, while confidence in the FFM in the event of an emergency remained high (Figure 6). Raw data are provided in Appendix D.



**Figure 5.** Peak inhalation pressure obtained at each work level during the first three phases of testing



**Figure 6.** Phase 3 subjective ratings of breathing resistance and confidence using the FFM during an emergency

During Phase 4 testing subjective breathing resistance levels remained low, while confidence in the FFM in an emergency remained high (Figure 7). Raw questionnaire rating data are provided in Appendix E.

However, one of the FFM's produced chatter when the diver turned his face up toward the surface, and free-flowed when he looked down at the bottom of the test pool. We found inadequate demand lever free play, and by adjusting it eliminated chatter and free-flow.

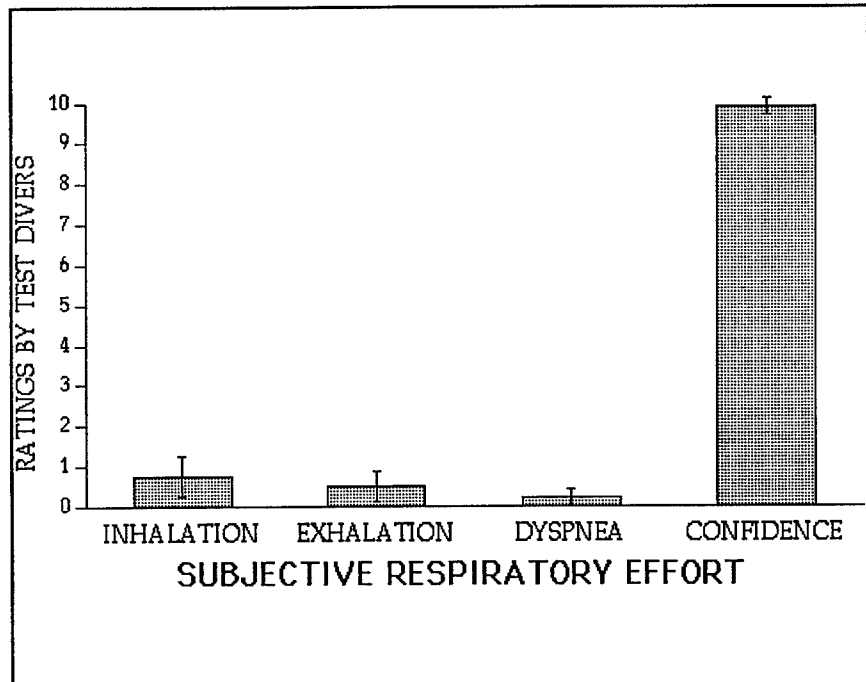

**Figure 7.** Phase 4 subjective ratings of breathing resistance and confidence using the FFM during an emergency

Series 2. Test divers needed to increase cracking pressure between 398 and 996 Pa (1.6 and 4.0 in H<sub>2</sub>O) to eliminate chatter. The average cracking pressure [ $\pm$  95% confidence interval] was  $575 \pm 60$  Pa ( $2.31 \pm .24$  in H<sub>2</sub>O). Raw data are provided in Appendix F.

## DISCUSSION

The original intent of this study was to determine whether reducing MK 24 FFM O/B pressure from 931 to 793 kPa would eliminate chatter while maintaining acceptable levels of breathing resistance. This strategy proved ineffective in reducing chatter, although subsequent adjustments successfully solved the problem. Resetting O/B to 931 kPa and installing a diffuser designed to reduce the venturi effect proved equally ineffective. However, chatter was completely eliminated by properly adjusting the demand lever free play between 1.59 and 3.18 mm, then setting the cracking pressure at 996 Pa (4 in H<sub>2</sub>O).

The latter adjustment is not part of normal set-up. According to the MRC<sup>5</sup>, cracking pressure is set by turning the adjustment plug out until the regulator develops an audible free-flow, turning the plug in until free flow stops, then turning it in an

additional half turn. The actual target cracking pressure expected from employing this strategy is not listed in the MRC<sup>5</sup>.

While chatter was universally eliminated among all divers after we adjusted demand lever free play and set cracking pressure to 996 Pa during Series 1, it is important to note that, during the Phase 1 and the early part of Phase 2 testing, those divers with narrower faces appeared more likely to experience chatter than divers with rounder faces, perhaps due to differences in mask fit.

Again, during Series 2 the narrow-faced divers generally required higher cracking pressures to eliminate chatter than their round-faced counterparts. In fact, the diver who required the highest cracking pressure to eliminate chatter in the one FFM also required the highest cracking pressure in the other mask. Both values were similar, i.e., 996 and 946 Pa.

We also found that the performance of the MK 24 FFM can change as a new poppet is "broken in." As the rubber poppet seat is continuously pressed against the metal seat of the regulator body it develops a ring-shaped indentation. Thus, initial adjustments made with a new poppet may require resetting after the FFM has been dived the first time or if it has "soaked" with O/B pressure continuously delivered to the regulator for several hours. After we had adjusted two regulators with "broken in" poppets, they remained free of chatter throughout 19 successive test dives each without requiring additional adjustment.

## **CONCLUSIONS / RECOMMENDATIONS**

1. In order to eliminate chatter at shallow depths, the MK 24 FFM must be properly adjusted so that demand lever free play is between 1.59 and 3.18 mm (.0625 and .125 in), and cracking pressure is set at  $747 \pm 249$  Pa ( $3 \pm 1$  in H<sub>2</sub>O). Some divers may find a lower cracking pressure is sufficient to eliminate chatter, while others may require a slightly higher pressure.
2. A revised form of the MRC<sup>5</sup> has been drafted (Appendix G) to reflect the proper maintenance procedure. Additional adjustments may need to be made after installing a new poppet. If a MK 24 FFM chatters, the demand lever free play and cracking pressure must be checked and appropriately adjusted.
3. While the MK 24 FFM will provide adequate breathing gas to a diver at rest or during short periods of exertion, NEDU cautions against diving the MK 24 FFM open circuit in the swimming mode, as its ability to provide gas to a continuously working diver has not been characterized. In the event such testing is deemed necessary, NEDU will be available to conduct manned FFM testing.

## REFERENCES

1. Jones, K. R. and L. J. Crepeau, *EX 24 Full Face Mask*, NEDU TR 5-93, Navy Experimental Diving Unit, May, 1993 (Unclassified).
2. Crepeau, L. J., *Testing of the SPECWAR Version of the MK 24 Full Face Mask (FFM) REV-1*, NAVSEA Task 94-025, Naval Sea Systems Command, 10560, Ser 00C3B/3632, 21 November 1994.
3. Crepeau, L. J., *Manned Evaluation of the MK 24 Full Face Mask Using Reduced Overbottom Pressure*, NEDU TP 94-47, December, 1994, Navy Experimental Diving Unit (Limited Distribution).
4. Crepeau, L. J., *Manned Evaluation of Chatter Levels in the MK 24 Full Face Mask While Varying Regulator Cracking Pressure*, NEDU TP 95-03, January, 1995, Navy Experimental Diving Unit (Limited Distribution).
5. Maintenance Requirement Card (Draft); MRC Code A-1R, Office of Naval Operations 4790/82 (Rev 2-82).

**APPENDIX A**

**MK 24 FFM PERFORMANCE EVALUATION QUESTIONNAIRE**

DATE: \_\_\_\_\_ TIME: \_\_\_\_\_ RIG NUMBER: \_\_\_\_\_  
NAME: \_\_\_\_\_ CONFIGURATION (A or B): \_\_\_\_\_

CIRCLE ONE: RED DIVER GREEN DIVER

For the following questions, provide a rating according to the following scale

NOTE: FOR QUESTION #5, 0=LEAST CONFIDENCE & 10=MOST CONFIDENCE:

- |     |                   |    |                   |
|-----|-------------------|----|-------------------|
| 0   | Not at all        | 5  | Severe            |
| 0.5 | Very, very slight | 6  |                   |
| 1   | Very slight       | 7  | Very severe       |
| 2   | Slight            | 8  |                   |
| 3   | Moderate          | 9  | Very, very severe |
| 4   | Somewhat severe   | 10 | Maximal           |

**WORK STAGE**

	BASELINE	50 WATTS	100 WATTS	150 WATTS
1. Detectable chatter				
2. Breathing resistance				
3. Breathing resistance				
4. Dyspnea score				
5. Level of confidence diving this rig during				



## APPENDIX B

### RAW DATA FROM SERIES 1, PHASE 1 TESTING

#### PERCEIVED CHATTER LEVELS:

<u>DIVE #</u>	<u>BASELINE</u>	<u>50 WATTS</u>	<u>100 WATTS</u>	<u>150 WATTS</u>
1	0.0	0.0	0.0	2.0
2	0.0	0.0	0.0	5.0
3	1.0	3.0	3.0	5.0
4	0.5	3.0	7.0	7.0
5	0.0	2.0	3.0	5.0
6	0.0	0.0	0.0	1.0
7	0.0	0.5	1.0	1.0
8	0.0	1.0	2.0	2.0
9	0.0	0.5	1.0	3.0
10	1.0	1.0	3.0	7.0
11	0.5	0.0	0.0	0.5
12	5.0	3.0	0.0	5.0
13	0.0	0.5	0.0	2.0
14	0.5	1.0	2.0	2.0
15	0.0	0.5	1.0	4.0
16	0.0	0.0	0.0	2.0
17	0.0	0.0	0.5	2.0
18	0.0	0.0	0.0	0.0
19	0.0	0.0	0.0	0.0
20	0.0	1.0	3.0	7.0

#### PERCEIVED INHALATION RESISTANCE:

<u>DIVE #</u>	<u>BASELINE</u>	<u>50 WATTS</u>	<u>100 WATTS</u>	<u>150 WATTS</u>
1	0.0	0.0	0.5	1.0
2	0.0	0.0	0.0	0.5
3	0.5	0.5	0.5	2.0
4	1.0	1.0	1.0	1.0
5	0.0	0.0	0.5	0.5
6	0.0	0.0	0.0	0.0
7	0.0	1.0	1.0	1.0
8	0.0	0.0	0.0	0.5
9	0.0	0.0	0.0	0.0
10	0.0	0.0	0.5	0.5
11	0.0	0.5	1.0	1.0
12	0.0	0.0	0.5	0.5
13	0.0	0.0	1.0	1.0
14	1.0	1.0	1.0	1.0
15	0.0	0.0	0.0	0.0
16	0.0	0.0	0.0	2.0
17	0.0	0.0	0.0	0.5
18	0.0	0.0	0.0	0.0
19	0.0	0.5	0.5	0.5
20	0.0	0.0	0.5	2.0

## APPENDIX B (Cont)

### PERCEIVED EXHALATION RESISTANCE:

<u>DIVE #</u>	<u>BASELINE</u>	<u>50 WATTS</u>	<u>100 WATTS</u>	<u>150 WATTS</u>
1	0.5	0.5	0.5	0.5
2	0.5	1.0	2.0	2.0
3	0.0	0.0	0.0	0.0
4	1.0	1.0	1.0	1.0
5	0.0	0.0	0.5	0.5
6	1.0	1.0	1.0	1.0
7	0.0	1.0	1.0	1.0
8	0.0	0.0	0.5	0.5
9	0.5	0.5	0.5	0.5
10	0.5	0.5	0.5	0.5
11	0.5	0.5	2.0	1.0
12	0.0	0.0	0.5	1.0
13	0.0	0.5	1.0	1.0
14	1.0	1.0	1.0	1.0
15	0.0	0.0	0.0	0.0
16	0.0	0.0	0.0	0.0
17	0.0	0.5	0.5	0.5
18	0.5	0.5	0.5	0.5
19	0.0	0.0	0.5	0.5
20	0.5	0.5	0.5	0.5

### DYSPNEA RATING:

<u>DIVE #</u>	<u>BASELINE</u>	<u>50 WATTS</u>	<u>100 WATTS</u>	<u>150 WATTS</u>
1	0.0	0.5	0.5	1.0
2	0.0	0.5	1.0	1.0
3	0.0	0.0	1.0	2.0
4	1.0	1.0	1.0	1.0
5	0.0	0.0	0.5	0.5
6	0.0	0.0	0.5	0.5
7	0.0	1.0	2.0	2.0
8	0.0	0.0	0.5	0.5
9	0.5	0.5	0.5	0.5
10	0.0	0.5	0.5	0.5
11	0.5	0.5	2.0	1.0
12	0.0	0.0	0.5	0.5
13	0.0	0.5	1.0	2.0
14	0.5	1.0	1.0	2.0
15	0.0	0.0	0.0	0.0
16	0.0	0.0	0.0	0.0
17	0.0	0.0	0.0	0.5
18	0.0	0.0	0.5	0.5
19	0.0	0.0	0.5	0.5
20	0.0	0.0	0.5	2.0

## APPENDIX B (Cont)

### CONFIDENCE DIVING THIS FFM IN AN EMERGENCY:

<u>DIVE #</u>	<u>BASELINE</u>	<u>50 WATTS</u>	<u>100 WATTS</u>	<u>150 WATTS</u>
1	8	8	8	8
2	8	8	8	7
3	9	9	9	8
4	9	9	8	8
5	10	10	10	10
6	10	10	10	10
7	10	9	9	9
8	10	10	10	10
9	10	10	10	10
10	10	10	10	10
11	10	10	10	10
12	10	10	10	10
13	10	10	10	10
14	8	8	8	8
15	10	10	10	9
16	10	10	10	10
17	10	10	10	9
18	9	9	9	9
19	10	10	10	10
20	10	10	10	8

### PEAK INHALATION LEVELS (cm H2O):

<u>DIVE #</u>	<u>BASELINE</u>	<u>50 WATTS</u>	<u>100 WATTS</u>	<u>150 WATTS</u>
1	12.8	11.2	8.3	10.1
2	13.7	11.0	12.1	11.9
3	9.6	9.4	12.2	10.4
4	9.6	12.3	12.3	12.8
5	8.8	3.6	5.6	3.4
6	7.7	9.3	9.5	12.6
7	6.8	8.3	9.0	9.3
8	10.8	13.3	14.2	15.2
9	5.0	4.1	4.4	13.1
10	11.3	7.7	6.8	7.5
11	13.0	12.0	10.8	11.2
12	7.7	7.7	9.5	9.2
13	14.1	11.0	8.7	11.2
14	14.8	13.6	17.2	10.8
15	8.9	12.3	11.7	10.9
16	7.5	5.2	11.0	9.5
17				
18	7.3	4.6	6.7	4.4
19	14.5	12.4	10.6	11.6
20	12.0	9.7	10.6	14.1

## APPENDIX C

### RAW DATA FROM SERIES 1, PHASE 2 TESTING

#### PERCEIVED CHATTER LEVELS:

<u>DIVE #</u>	<u>BASELINE</u>	<u>50 WATTS</u>	<u>100 WATTS</u>	<u>150 WATTS</u>
1	0.0	0.0	0.0	0.0
2	0.0	1.0	2.0	3.0
3	0.0	0.0	0.0	0.0
4	3.0	3.0	3.0	1.0
5	0.5	0.0	2.0	3.0
6	0.0	0.0	0.0	0.0
7	0.0	0.0	0.0	0.0
8	0.0	0.0	0.0	0.0
9	0.0	0.0	0.0	0.0
10	0.0	0.0	0.0	0.0
11	0.0	0.0	0.0	0.0
12	0.0	0.0	0.0	0.0
13	0.0	0.0	0.0	0.0
14	0.0	0.0	0.0	0.0
15	0.0	0.0	0.0	0.0
16	0.0	0.0	0.0	0.0
17	0.0	0.0	0.0	0.0
18	0.0	0.0	0.0	0.0
19	0.0	0.0	0.0	0.0
20	0.0	0.0	0.0	0.0

#### PERCEIVED INHALATION RESISTANCE:

<u>DIVE #</u>	<u>BASELINE</u>	<u>50 WATTS</u>	<u>100 WATTS</u>	<u>150 WATTS</u>
1	0.0	0.5	0.5	2.0
2	0.0	0.5	0.5	1.0
3	0.0	0.0	0.5	0.5
4	0.0	0.0	0.0	0.0
5	0.0	0.0	0.5	0.5
6	1.0	1.0	1.0	0.5
7	0.0	0.0	0.0	0.5
8	0.0	0.0	0.0	0.0
9	0.0	0.0	0.0	0.5
10	0.5	1.0	1.0	2.0
11	0.5	0.5	0.5	0.5
12	0.5	0.5	1.0	2.0
13	0.0	0.5	0.5	0.5
14	0.0	0.0	0.5	0.5
15	2.0	2.0	2.0	2.0
16	2.0	2.0	2.0	2.0
17	0.0	0.0	0.5	0.5
18	0.0	0.0	0.0	0.0
19	0.0	0.0	0.5	0.5
20	0.0	0.0	0.0	0.0

### APPENDIX C (Cont)

PERCEIVED EXHALATION RESISTANCE:

<u>DIVE #</u>	<u>BASELINE</u>	<u>50 WATTS</u>	<u>100 WATTS</u>	<u>150 WATTS</u>
1	0.0	0.0	0.5	1.0
2	0.0	0.0	0.0	0.5
3	0.0	0.0	0.0	0.0
4	0.0	0.0	0.0	0.5
5	0.0	0.0	0.0	0.0
6	1.0	1.0	1.0	1.0
7	0.0	0.0	0.0	0.5
8	0.0	0.0	0.0	0.0
9	0.5	0.5	0.5	0.5
10	0.0	0.5	0.5	2.0
11	0.0	0.0	0.0	1.0
12	0.0	0.0	0.5	1.0
13	0.5	0.5	1.0	1.0
14	0.5	0.5	1.0	1.0
15	0.0	0.0	0.0	0.0
16	1.0	1.0	1.0	1.0
17	0.0	0.0	0.5	0.5
18	0.0	0.0	0.5	0.5
19	0.5	0.5	1.0	1.0
20	0.5	0.5	0.5	1.0

DYSPNEA RATING:

<u>DIVE #</u>	<u>BASELINE</u>	<u>50 WATTS</u>	<u>100 WATTS</u>	<u>150 WATTS</u>
1	0.0	0.5	1.0	2.0
2	0.0	0.5	0.0	0.5
3	0.0	0.0	0.5	0.5
4	0.0	0.0	0.0	0.5
5	0.0	0.0	0.0	0.0
6	1.0	1.0	1.0	2.0
7	0.0	0.0	0.0	2.0
8	0.0	0.0	0.0	0.0
9	0.0	0.0	0.5	0.5
10	0.0	0.5	0.5	2.0
11	0.0	0.0	0.0	1.0
12	0.0	0.0	0.5	1.0
13	0.5	0.5	1.0	1.0
14	0.0	0.5	0.5	0.5
15	0.0	0.0	0.5	2.0
16	2.0	1.0	2.0	2.0
17	0.0	0.0	0.0	0.5
18	0.0	0.0	0.0	0.5
19	0.0	0.0	0.5	1.0
20	0.0	0.0	0.0	0.5

## APPENDIX C (Cont)

### CONFIDENCE DIVING THIS FFM IN AN EMERGENCY:

<u>DIVE #</u>	<u>BASELINE</u>	<u>50 WATTS</u>	<u>100 WATTS</u>	<u>150 WATTS</u>
1	10	10	10	10
2	10	10	10	9
3	10	10	10	10
4	10	10	10	10
5	10	10	10	9
6	8	8	8	8
7	10	10	10	10
8	10	10	10	10
9	9	9	9	9
10	10	10	10	10
11	10	10	8	8
12	10	10	10	10
13	10	10	10	10
14	8	8	8	8
15	9	9	9	9
16	9	9	9	9
17	10	10	10	10
18	10	10	10	10
19	9	9	9	9
20	10	10	10	10

### PEAK INHALATION LEVELS (cm H2O):

<u>DIVE #</u>	<u>BASELINE</u>	<u>50 WATTS</u>	<u>100 WATTS</u>	<u>150 WATTS</u>
1	10.9	7.5	11.2	13.2
2	8.1	6.9	7.7	10.3
3	10.4	11.1	11.7	10.4
4	14.6	8.6	6.8	8.4
5	10.7	14.1	12.1	12.4
6	15.2	15.0	16.7	15.1
7	15.4	14.0	16.0	14.0
8	17.2	12.5	12.0	12.8
9	7.9	11.1	8.8	10.9
10	16.2	14.2	15.7	16.4
11	12.9	9.7	12.6	11.7
12	13.3	14.3	14.8	16.1
13	9.8	10.6	11.7	13.2
14	15.3	14.3	17.0	18.7
15	12.2	9.1	10.6	11.3
16	14.5	16.2	16.3	15.3
17	10.0	7.7	9.2	8.6
18	13.5	15.8	17.0	20.0
19	8.5	8.7	9.8	11.1
20	9.9	10.8	10.2	10.0

APPENDIX D

RAW DATA FROM SERIES 1, PHASE 3 TESTING

PERCEIVED CHATTER LEVELS:

<u>DIVE #</u>	<u>BASELINE</u>	<u>50 WATTS</u>	<u>100 WATTS</u>	<u>150 WATTS</u>
1	0.0	0.0	0.0	0.0
2	0.0	0.0	0.0	0.0
3	0.0	0.0	0.0	0.0
4	0.0	0.0	0.0	0.0
5	0.0	0.0	0.0	0.0
6	0.0	0.0	0.0	0.0
7	0.0	0.0	0.0	0.0
8	0.0	0.0	0.0	0.0
9	0.0	0.0	0.0	0.0
10	0.0	0.0	0.0	0.0
11	0.0	0.0	0.0	0.0
12	0.0	0.0	0.0	0.0
13	0.0	0.0	0.0	0.0
14	0.0	0.0	0.0	0.0
15	0.0	0.0	0.0	0.0
16	0.0	0.0	0.0	0.0
17	0.0	0.0	0.0	0.0
18	0.0	0.0	0.0	0.0
19	0.0	0.0	0.0	0.0
20	0.0	0.0	0.0	0.0
21	0.0	0.0	0.0	0.0
22	0.0	0.0	0.0	0.0
23	0.0	0.0	0.0	0.0
24	0.0	0.0	0.0	0.0
25	0.0	0.0	0.0	0.0
26	0.0	0.0	0.0	0.0

## APPENDIX D (Cont)

### PERCEIVED INHALATION RESISTANCE:

<u>DIVE #</u>	<u>BASELINE</u>	<u>50 WATTS</u>	<u>100 WATTS</u>	<u>150 WATTS</u>
1	0.0	0.0	0.0	0.0
2	0.0	0.0	0.0	0.0
3	0.0	0.0	0.0	0.0
4	0.5	0.5	0.5	0.5
5	0.0	0.5	0.5	0.5
6	1.0	1.0	1.0	1.0
7	1.0	1.0	1.0	1.0
8	1.0	0.0	0.0	0.0
9	0.0	0.0	0.0	0.5
10	0.0	0.0	0.0	0.0
11	0.0	0.5	0.5	0.5
12	0.5	0.5	1.0	1.0
13	0.0	0.0	0.0	0.0
14	0.0	0.5	0.5	0.0
15	1.0	1.0	1.0	1.0
16	0.0	0.0	0.0	0.0
17	0.5	0.5	2.0	3.0
18	0.0	0.0	0.5	0.5
19	0.0	0.0	0.0	0.0
20	0.0	0.0	0.0	0.0
21	0.0	0.5	0.5	0.5
22	0.0	0.0	0.0	0.0
23	0.0	0.0	0.5	0.5
24	0.5	0.0	0.0	0.5
25	0.0	0.5	1.0	1.0
26	0.5	1.0	1.0	2.0



APPENDIX D (Cont)

PERCEIVED EXHALATION RESISTANCE:

<u>DIVE #</u>	<u>BASELINE</u>	<u>50 WATTS</u>	<u>100 WATTS</u>	<u>150 WATTS</u>
1	0.0	0.0	0.0	0.0
2	0.0	0.0	0.0	0.0
3	0.5	0.5	0.5	0.5
4	0.5	0.5	0.5	0.5
5	0.5	0.5	0.5	0.5
6	1.0	1.0	1.0	1.0
7	1.0	1.0	1.0	1.0
8	0.5	0.0	0.0	0.0
9	0.5	0.5	0.5	1.0
10	1.0	0.5	1.0	0.5
11	0.0	0.0	0.0	0.5
12	0.5	0.5	0.5	0.5
13	0.0	0.5	0.5	0.5
14	0.5	0.5	0.5	0.5
15	0.5	0.0	0.0	0.0
16	0.5	0.5	0.5	1.0
17	0.0	0.0	0.0	0.0
18	0.0	0.0	0.0	0.0
19	0.0	0.0	0.0	0.0
20	0.0	0.0	0.0	0.0
21	0.0	0.0	0.5	0.5
22	0.0	0.0	0.0	0.0
23	0.0	0.0	0.5	0.5
24	0.0	0.0	0.0	0.0
25	0.0	0.0	0.0	0.0
26	0.5	0.5	1.0	1.0

## APPENDIX D (Cont)

### DYSPNEA RATING:

<u>DIVE #</u>	<u>BASELINE</u>	<u>50 WATTS</u>	<u>100 WATTS</u>	<u>150 WATTS</u>
1	0.0	0.0	0.0	0.0
2	0.0	0.0	0.0	0.0
3	0.5	0.5	0.5	0.5
4	0.5	0.5	0.5	0.5
5	0.0	0.0	0.0	0.0
6	1.0	1.0	1.0	1.0
7	1.0	1.0	1.0	1.0
8	0.0	0.0	0.0	0.0
9	0.0	0.0	0.5	0.5
10	0.0	0.0	0.0	0.5
11	0.0	0.0	0.0	0.5
12	0.0	0.0	0.5	0.5
13	0.0	0.0	0.0	0.0
14	0.0	0.5	0.5	0.5
15	0.0	0.0	0.5	1.0
16	0.0	0.0	0.5	0.5
17	0.0	0.0	1.0	2.0
18	0.0	0.0	0.5	0.5
19	0.0	0.0	0.0	0.0
20	0.0	0.0	0.0	0.0
21	0.0	0.5	0.5	0.5
22	0.0	0.0	0.0	0.0
23	0.0	0.0	0.0	0.0
24	0.0	0.0	0.0	0.0
25	0.0	0.0	0.5	0.5
26	0.5	1.0	1.0	2.0

APPENDIX D (Cont)

CONFIDENCE DIVING THIS FFM IN AN EMERGENCY:

<u>DIVE #</u>	<u>BASELINE</u>	<u>50 WATTS</u>	<u>100 WATTS</u>	<u>150 WATTS</u>
1	10	10	10	10
2	10	10	10	10
3	10	10	10	10
4	10	10	10	10
5	10	10	10	10
6	9	9	9	9
7	8	8	8	8
8	10	10	10	10
9	8	8	8	8
10	9	10	10	10
11	10	10	10	10
12	10	10	10	10
13	9	9	9	9
14	10	10	10	10
15	9	9	9	9
16	10	10	10	10
17	10	10	10	9
18	10	10	10	10
19	10	10	10	10
20	10	10	10	10
21	10	10	10	10
22	10	10	10	10
23	10	10	10	10
24	10	10	10	10
25	10	10	10	10
26	9	9	9	10

## APPENDIX D (Cont)

### PEAK INHALATION LEVELS (cm H<sub>2</sub>O):

<u>DIVE #</u>	<u>BASELINE</u>	<u>50 WATTS</u>	<u>100 WATTS</u>	<u>150 WATTS</u>
1	10.2	18.4	10.3	9.6
2	21.4	15.3	13.0	18.4
3	7.8	8.9	10.7	11.8
4	8.9	10.9	11.7	13.1
5	4.3	6.3	10.3	7.2
6	13.9	15.5	16.5	14.7
7	14.3	12.1	13.2	13.0
8	18.0	16.9	12.3	10.6
9	13.4	14.6	12.0	13.0
10	21.4	18.4	18.1	21.4
11	16.8	8.0	9.5	12.3
12	20.5	20.9	16.2	17.3
13	12.0	12.5	12.5	13.1
14	17.7	19.7	18.5	13.0
15	12.5	10.7	13.0	12.5
16	13.9	15.4	14.1	14.6
17	13.9	8.6	9.8	12.4
18	21.8	24.9	22.5	23.0
19	13.2	11.2	14.6	14.9
20	25.8	21.8	22.2	26.0
21	8.9	11.9	15.3	N/A
22	18.9	22.4	21.7	18.9
23	12.6	11.9	11.4	12.6
24	15.2	20.1	20.5	19.4
25	13.2	14.4	12.5	13.9
26	19.3	20.8	21.1	22.4

## APPENDIX E

### RAW DATA FROM SERIES 1, PHASE 4 TESTING

<u>DIVE NUMBER</u>	<u>PERCEIVED CHATTER LEVEL</u>	<u>PERCEIVED INHALATION RESISTANCE</u>	<u>PERCEIVED EXHALATION RESISTANCE</u>	<u>DYSPNEA RATING</u>	<u>CONFIDENCE DIVING FFM DURING EMERGENCY</u>
1	0.0	0.0	0.0	0.0	10
2	0.0	0.5	0.5	0.5	10
3	0.0	1.0	0.5	1.0	10
4	0.0	0.0	0.5	0.0	10
5	0.0	0.5	0.0	0.0	10
6	2.0	2.0	0.0	0.0	10
7	3.0	0.5	0.5	0.0	10
8	0.5	1.0	0.5	0.0	9
9	0.0	0.0	0.0	0.0	10
10	0.0	2.0	2.0	0.5	10

## APPENDIX F

### RAW DATA FROM SERIES 2 TESTING

DIVE #	NUMBER OF ADJUSTMENT PLUG TURNS REQUIRED TO ELIMINATE CHATTER	RESULTING INHALATION CRACKING PRESSURE [in H2O (Pa)]
1	1.25	2.2 (548.0)
2	0.25	1.8 (448.3)
3	2.00	3.0 (747.2)
4	1.00	2.0 (498.1)
5	1.00	2.0 (498.1)
6	1.50	2.8 (697.4)
7	1.00	2.2 (548.0)
8	0.50	2.4 (597.8)
9	0.50	1.6 (398.5)
10	0.75	1.8 (448.3)
11	1.50	2.6 (647.6)
12	2.50	3.6 (896.6)
13	1.25	2.2 (548.0)
14	2.50	4.0 (996.3)
15	0.50	1.8 (448.3)
16	0.75	2.0 (498.1)
17	1.00	2.2 (548.0)
18	1.50	3.0 (747.2)
19	1.25	2.2 (548.0)
20	1.25	1.6 (398.5)
21	0.25	1.6 (398.5)
22	1.00	2.2 (548.0)
23	1.25	2.2 (548.0)
24	1.25	2.4 (597.8)

## APPENDIX G

### DRAFT MAINTENANCE REQUIREMENT CARD FOR MK 24 FFM OPEN CIRCUIT REGULATOR

SHIP SYSTEM	SUBSYSTEM  Full Face Mask Assembly (FFM) MK 24 MOD 0	MRC CODE  A-2R			
SYSTEM  MK 16	EQUIPMENT  Open-Circuit Demand Regulator	NEC  533X/ 532X	M/H  1.0		
MAINTENANCE REQUIREMENT DESCRIPTION  1. Overhaul open-circuit demand regulator.		TOTAL M/H 1.0			
SAFETY PRECAUTIONS  1. Forces afloat comply with Navy Safety Precautions for Forces Afloat, OPNAVINST 5100 series. 2. Observe safety precautions as described in Safety Summary, MK 16 Mod 0 Technical Manual, SS600-AH-MMA-010. 3. Strict cleanliness is imperative in maintaining the FFM. Contamination may cause serious malfunctions and result in diver injury or death.		ELAPSED TIME 1.0			
<p>TOOLS, PARTS, MATERIALS, TEST EQUIPMENT</p> <table style="width: 100%; border: none;"> <tr> <td style="width: 50%; vertical-align: top;"> <p><b>TOOLS</b></p> <ol style="list-style-type: none"> <li>1. [1983] Wrench, open-end, 11/16", 2 ea</li> <li>2. [1194] Screwdriver, flat-tip</li> <li>3. O-ring extraction tool, Parker Hannifin, P/N 887-200</li> <li>4. Regulator retainer wrench, P/N 6696786</li> <li>5. Diaphragm retainer wrench, P/N 6696477</li> <li>6. [2274] Pail, utility plastic</li> <li>7. [0164] Brush, cleaning</li> <li>8. [0294] Cloth, lint free</li> <li>9. [1817] Bottle, plastic, clear</li> <li>10. Regulator test whip, P/N 6696987</li> </ol> <p><b>PARTS</b></p> <ol style="list-style-type: none"> <li>1. Diaphragm assembly, P/N 6696315 (item 16)</li> <li>2. O-ring, P/N M83248/1-011 (item 11)</li> <li>3. O-ring, P/N 6696518-4, 2 ea (item 4)</li> <li>4. O-ring, P/N 6696518-11 (item 21)</li> <li>5. O-ring, P/N 6696518-1 (item 22)</li> </ol> </td> <td style="width: 50%; vertical-align: top;"> <ol style="list-style-type: none"> <li>6. O-ring, P/N 6696518-9 (item 2)</li> <li>7. O-ring, P/N 6696518-3 (item 7)</li> <li>8. Poppet, P/N 6696529 (item 8)</li> <li>9. Gasket, P/N 6696308 (item 19)</li> </ol> <p><b>MATERIALS</b></p> <ol style="list-style-type: none"> <li>1. [1259] Lubricant, silicone compound, MIL-S-8660B</li> <li>2. [0366] Detergent, general purpose (NID), (MIL-D-16791, Type 1). Hazardous Material Group 3</li> </ol> <p><b>TEST EQUIPMENT</b></p> <ol style="list-style-type: none"> <li>1. Clean, LP Diver's regulated air source of air.</li> <li>2. Manometer, P/N 6696792 (item 28)</li> <li>3. Tube, flexible, clear, 3/16" ID, 3 ft, P/N 6696793 (item 30)</li> <li>4. Fitting, adapter, 1/4" tube, 7/16-20, P/N 6696794 (item 29)</li> </ol> </td> </tr> </table> <p><b>NOTE:</b> Numbers in brackets can be referred to Standard PMS Materials Identification Guide (SPMIG) for stock number identification.</p>				<p><b>TOOLS</b></p> <ol style="list-style-type: none"> <li>1. [1983] Wrench, open-end, 11/16", 2 ea</li> <li>2. [1194] Screwdriver, flat-tip</li> <li>3. O-ring extraction tool, Parker Hannifin, P/N 887-200</li> <li>4. Regulator retainer wrench, P/N 6696786</li> <li>5. Diaphragm retainer wrench, P/N 6696477</li> <li>6. [2274] Pail, utility plastic</li> <li>7. [0164] Brush, cleaning</li> <li>8. [0294] Cloth, lint free</li> <li>9. [1817] Bottle, plastic, clear</li> <li>10. Regulator test whip, P/N 6696987</li> </ol> <p><b>PARTS</b></p> <ol style="list-style-type: none"> <li>1. Diaphragm assembly, P/N 6696315 (item 16)</li> <li>2. O-ring, P/N M83248/1-011 (item 11)</li> <li>3. O-ring, P/N 6696518-4, 2 ea (item 4)</li> <li>4. O-ring, P/N 6696518-11 (item 21)</li> <li>5. O-ring, P/N 6696518-1 (item 22)</li> </ol>	<ol style="list-style-type: none"> <li>6. O-ring, P/N 6696518-9 (item 2)</li> <li>7. O-ring, P/N 6696518-3 (item 7)</li> <li>8. Poppet, P/N 6696529 (item 8)</li> <li>9. Gasket, P/N 6696308 (item 19)</li> </ol> <p><b>MATERIALS</b></p> <ol style="list-style-type: none"> <li>1. [1259] Lubricant, silicone compound, MIL-S-8660B</li> <li>2. [0366] Detergent, general purpose (NID), (MIL-D-16791, Type 1). Hazardous Material Group 3</li> </ol> <p><b>TEST EQUIPMENT</b></p> <ol style="list-style-type: none"> <li>1. Clean, LP Diver's regulated air source of air.</li> <li>2. Manometer, P/N 6696792 (item 28)</li> <li>3. Tube, flexible, clear, 3/16" ID, 3 ft, P/N 6696793 (item 30)</li> <li>4. Fitting, adapter, 1/4" tube, 7/16-20, P/N 6696794 (item 29)</li> </ol>
<p><b>TOOLS</b></p> <ol style="list-style-type: none"> <li>1. [1983] Wrench, open-end, 11/16", 2 ea</li> <li>2. [1194] Screwdriver, flat-tip</li> <li>3. O-ring extraction tool, Parker Hannifin, P/N 887-200</li> <li>4. Regulator retainer wrench, P/N 6696786</li> <li>5. Diaphragm retainer wrench, P/N 6696477</li> <li>6. [2274] Pail, utility plastic</li> <li>7. [0164] Brush, cleaning</li> <li>8. [0294] Cloth, lint free</li> <li>9. [1817] Bottle, plastic, clear</li> <li>10. Regulator test whip, P/N 6696987</li> </ol> <p><b>PARTS</b></p> <ol style="list-style-type: none"> <li>1. Diaphragm assembly, P/N 6696315 (item 16)</li> <li>2. O-ring, P/N M83248/1-011 (item 11)</li> <li>3. O-ring, P/N 6696518-4, 2 ea (item 4)</li> <li>4. O-ring, P/N 6696518-11 (item 21)</li> <li>5. O-ring, P/N 6696518-1 (item 22)</li> </ol>	<ol style="list-style-type: none"> <li>6. O-ring, P/N 6696518-9 (item 2)</li> <li>7. O-ring, P/N 6696518-3 (item 7)</li> <li>8. Poppet, P/N 6696529 (item 8)</li> <li>9. Gasket, P/N 6696308 (item 19)</li> </ol> <p><b>MATERIALS</b></p> <ol style="list-style-type: none"> <li>1. [1259] Lubricant, silicone compound, MIL-S-8660B</li> <li>2. [0366] Detergent, general purpose (NID), (MIL-D-16791, Type 1). Hazardous Material Group 3</li> </ol> <p><b>TEST EQUIPMENT</b></p> <ol style="list-style-type: none"> <li>1. Clean, LP Diver's regulated air source of air.</li> <li>2. Manometer, P/N 6696792 (item 28)</li> <li>3. Tube, flexible, clear, 3/16" ID, 3 ft, P/N 6696793 (item 30)</li> <li>4. Fitting, adapter, 1/4" tube, 7/16-20, P/N 6696794 (item 29)</li> </ol>				
LOCATION	DATE				

Page 1 of 5

## APPENDIX G (Cont)

### PROCEDURE

#### CERTIFICATION NOTES:

1. This maintenance involves equipment and/or systems within the scope of certification. Applicable certification procedures must be followed.
2. For the purposes of sustaining system certification, use only replacement parts that are specified in approved documentation and certified for contact magnetic effect requirements.

**NOTE 1:** Accomplish annually or as required.

**WARNING:** Strict cleanliness is imperative in maintaining the FFM. Contamination may cause serious malfunctions and result in diver injury or death.

#### 1. Overhaul open-circuit demand regulator.

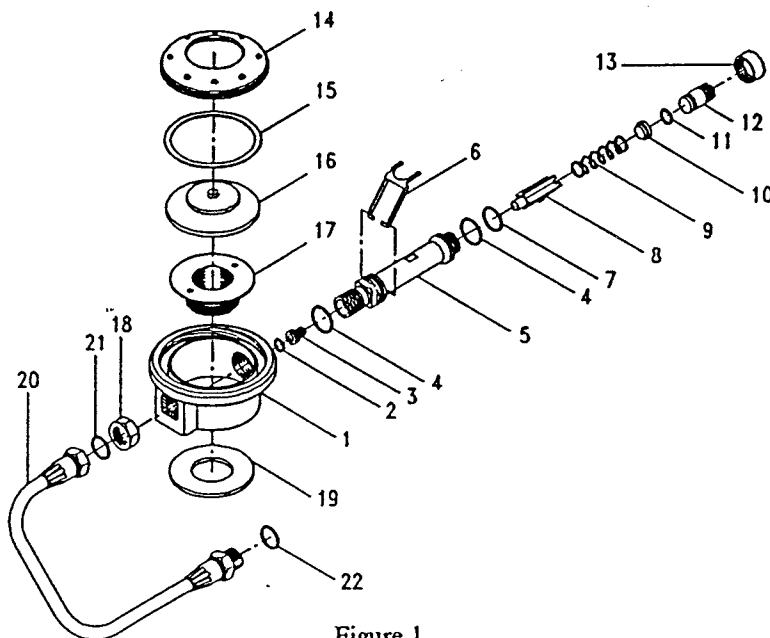

Figure 1

- a. Disassemble open-circuit demand regulator.
  - (1) Place FFM or regulator on clean workbench.
  - (2) Remove demand regulator hose assembly (20). Remove and discard O-rings (21,22).
  - (3) Unscrew and remove diaphragm retainer (14); remove thrust washer (15) and diaphragm assembly (16) from regulator body (1). Discard diaphragm assembly.
  - (4) Unscrew and remove inlet tube nut (18) from inlet tube (5). Fully depress and hold the demand lever (6) and slide inlet tube (5) from the regulator body (1).
  - (5) Unscrew regulator retainer (17) from switchover assembly. Remove regulator body and gasket (19). Discard gasket.
  - (6) Unscrew and remove inlet cap (13), adjustment plug (12), O-ring (11), and spring pad (10) from inlet tube (5). Discard O-ring.

Page 2 of 5



## APPENDIX G (Cont)

### PROCEDURE (Cont)

- (7) Remove demand lever (6) from inlet tube.
  - (8) Remove spring (9) and poppet (8) from inlet tube. Discard poppet.
  - (9) Remove and discard two O-rings (4) and O-ring (7) from inlet tube.
  - (10) Unscrew adjustment orifice (3); insert a pencil at opposite end of inlet tube and push adjustment orifice from inlet tube. Remove and discard O-ring (2).
- b. Inspect and clean open-circuit demand regulator
- (1) Prepare a cleaning solution by mixing 1/2 teaspoon of NID to one gallon of warm fresh water (1 to 750 mixing ratio).
  - (2) Carefully clean all surfaces of the demand regulator assembly and components using the cleaning brush and lint-free cloths. Thoroughly wet all surfaces with cleaning solution and briskly scrub to remove all traces of dirt, corrosion, and old lubricant.
  - (3) Thoroughly rinse all components with warm fresh water. Perform a shake test of a small rinse sample to ensure the absence of detergent residue.
  - (4) Allow components to air dry thoroughly.
  - (5) Using a bright white light, inspect all surfaces and O-ring grooves for nicks, corrosion, contamination, and damage. Replace parts as necessary.
- c. Reassemble open-circuit demand regulator.

**NOTE 2:** Lubricate each new O-ring with silicone compound before installation.

- (1) Install O-ring (2) on adjustment orifice (3) and screw adjustment orifice fully into inlet tube (5). Back out the adjustment orifice one and one-half turns.
- (2) Install demand lever (6) on inlet tube. Ensure demand lever is installed on the top side of the inlet tube (square on top of tube faces lever).
- (3) Hold demand lever up and install poppet (8) in inlet tube. Ensure poppet is installed with protrusions pointed down. Lightly spread legs of the lever and ensure the poppet has dropped down to orifice.
- (4) Install O-ring (11) on adjustment plug (12).
- (5) Install spring (9) and spring pad (10) in inlet tube. Screw adjustment plug into inlet tube until two female threads are showing at end of inlet tube.
- (6) Install two O-rings (4) and O-ring (7) on inlet tube.
- (7) Place regulator retainer (17) through hole in bottom of regulator body (1) and install new gasket (19) around regulator retainer on outside of regulator body.
- (8) Secure regulator body (1) to switchover assembly by screwing regulator retainer (17) into switchover body.
- (9) Fully depress and hold demand lever (6) while sliding inlet tube into regulator body (1). Slowly release demand lever. Slide inlet tube in regulator body until threads protrude. Install inlet tube nut (18) on inlet tube, hand tighten until inlet tube is fully seated into regulator body, and turn with moderate effort to seat nut with wrench.
- (10) Install O-ring (21) in swivel end of regulator inlet hose (20).
- (11) Install O-ring (22) on male end of inlet hose (20).
- (12) Install male end of inlet hose (20) into the switchover plug valve body outlet and tighten.
- (13) Attach swivel end of regulator connecting hose assembly (20) to inlet tube and tighten.

Page 3 of 5

## APPENDIX G (Cont)

### PROCEDURE (Cont)

- d. Check and adjust the demand lever free play.
- (1) Connect the FFM to a first stage scuba regulator which has been adjusted to 135 psig  $\pm$  5 psig or to a suitable scuba test stand. Ensure the switchover handle is in the open-circuit position. Slowly apply air pressure.
  - (2) Check the free play at the top of the demand lever (6) by lightly brushing a finger past the end of the demand lever. If the free play is 1/16 inch to 1/8 inch, the lever is properly adjusted. If the free play is not 1/16 inch to 1/8 inch, secure air supply, vent pressure, and remove the regulator connecting hose from the inlet tube.

**CAUTION:** Whenever the adjustment orifice is turned, the demand lever must be depressed or the poppet will be damaged.

- (3) To decrease free play, turn the orifice (3) counterclockwise with a flat blade screwdriver. To increase free play, turn the orifice clockwise. Make small adjustments. The orifice should not be turned more than 1/8 of a turn in between lever end play checks.
  - (4) Reinstall the regulator connecting hose (20) and tighten.
  - (5) Slowly apply air pressure at 135 psig and check lever free play. Repeat steps 2 through 5 as necessary to obtain the proper lever free play.
  - (6) Install the new diaphragm assembly (16) onto the demand regulator body (1), ensuring it is properly seated.
  - (7) Install the thrust washer (15) with smooth side against the diaphragm assembly (16).
  - (8) Carefully screw down the diaphragm retainer (14) and lightly tighten using the diaphragm retainer wrench.
- e. Adjust demand regulator cracking pressure (Figure 2).
- (1) Prepare manometer (28) by adding clean water to unit until a suitable "zero" level is reached in the middle of the U-tube. Ensure all water is inside clear U-tube and both tube fitting valves are open.
  - (2) See Figure 2 for illustration. Remove drinking tube plug (15) from FFM switchover body and install port adapter (29). Slip flexible tube (30) over port adapter fitting and manometer tube connection. Other manometer tube connection remains open to atmosphere. Ensure vacuum-tight connections.
  - (3) Remove adjustment plug cap (13) from demand regulator. Slowly turn adjustment plug (12) counterclockwise while intermittently pressing purge button until regulator free flow develops. Turn adjustment plug clockwise until free flow stops. Don mask and inhale slowly while observing manometer. The pressure in inches of water is the total height difference in water levels between the two water column levels. This is minimum cracking pressure.
  - (4) Slowly inhale in mask while turning adjustment plug clockwise 1/4 turn at a time. Increase cracking pressure to fall in the range of 3 inches,  $\pm$  1 inch of water. Check mask for proper operation and absence of flutter. Adjust cracking pressure within above range as necessary. Finally, check demand lever freeplay per above procedure. Adjust as necessary and repeat cracking pressure adjustment if required. Remove test equipment and reinstall cap (13) and plug (15).

# APPENDIX G (Cont)

PROCEDURE (Cont)

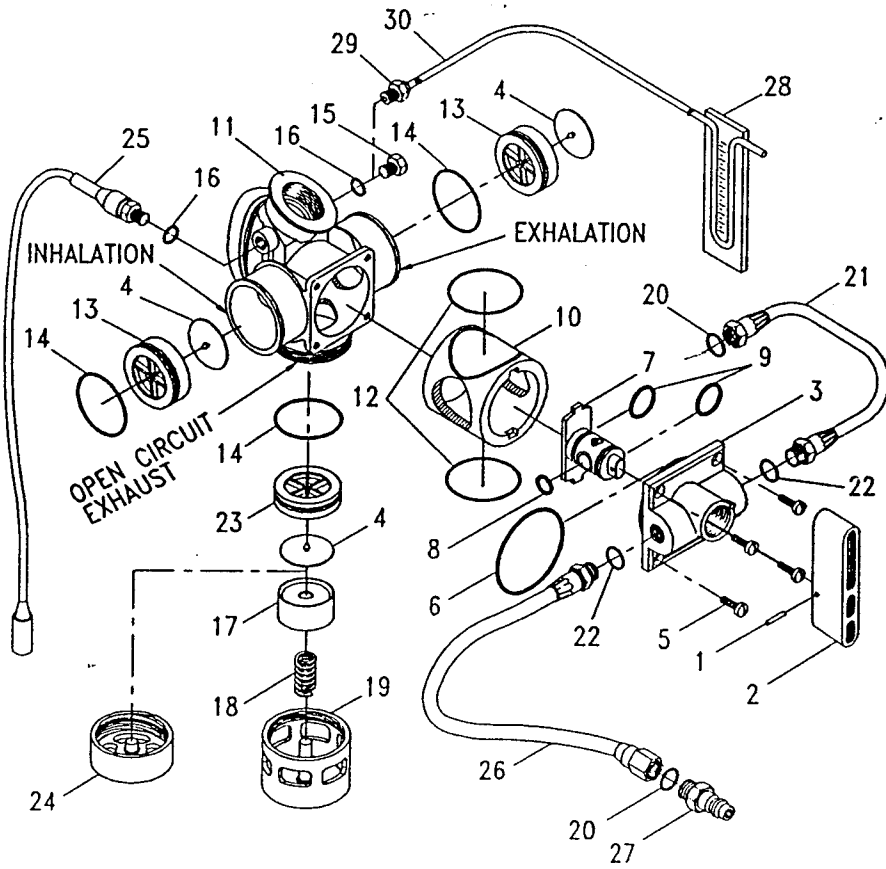

Figure 2

Page 5 of 5