

ate technical note techn

UHF Low Density Radio Communications Link (LDRCL) Operational Test and Evaluation (OT&E) Integration and OT&E Operational Final Test Report

Michael R. Melillo

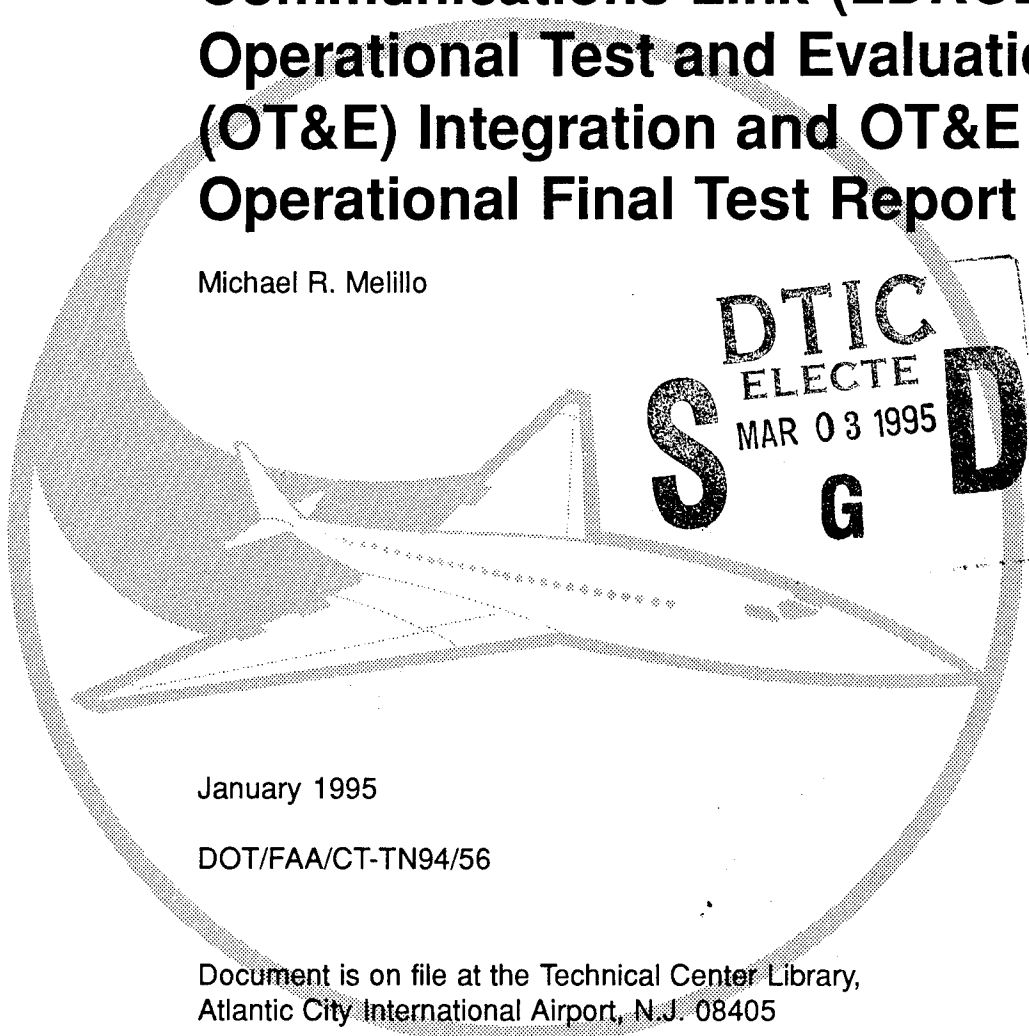

DTIC
ELECTE
MAR 03 1995
S G D

January 1995

DOT/FAA/CT-TN94/56

Document is on file at the Technical Center Library,
Atlantic City International Airport, N.J. 08405



U.S. Department of Transportation
Federal Aviation Administration

Technical Center
Atlantic City Airport, NJ 08405

DISTRIBUTION STATEMENT A
Approved for public release;
Distribution Unlimited

19950227 111

NOTICE

This document is disseminated under the sponsorship of the U.S. Department of Transportation in the interest of information exchange. The United States Government assumes no liability for the contents or use thereof.

The United States Government does not endorse products or manufacturers. Trade or manufacturers' names appear herein solely because they are considered essential to the objective of this report.

1. Report No. DOT/FAA/CT-TN94/56	2. Government Accession No.	3. Recipient's Catalog No.	
4. Title and Subtitle UHF LOW DENSITY RADIO COMMUNICATIONS LINK (LDRCL) OPERATIONAL TEST AND EVALUATION (OT&E) INTEGRATION AND OT&E OPERATIONAL FINAL TEST REPORT		5. Report Date January 1995	
		6. Performing Organization Code	
7. Author(s) Michael R. Melillo		8. Performing Organization Report No. DOT/FAA/CT-TN94/56	
9. Performing Organization Name and Address U.S. Department of Transportation Federal Aviation Administration Technical Center Atlantic City International Airport, NJ 08405		10. Work Unit No. (TRAIS)	
		11. Contract or Grant No.	
12. Sponsoring Agency Name and Address U.S. Department of Transportation Federal Aviation Administration Technical Center Atlantic City International Airport, NJ 08405		13. Type of Report and Period Covered Technical Note	
		14. Sponsoring Agency Code	
15. Supplementary Notes			
16. Abstract <p>This report contains the results of the Operational Test and Evaluation (OT&E) Integration and OT&E Operational Testing of the Commercial-Off-The-Shelf (COTS) Low Density Radio Communications Link's (LDRCL) Ultra-High Frequency (UHF) radio system. The OT&E testing was accomplished by first testing the LDRCL equipment against its equipment specification (FAA-E-2853A), and then performing OT&E testing at the key sites; Mina and Tonopah, Nevada. These tests prove that the UHF LDRCL equipment can fulfill its mission in the National Airspace System (NAS) and that it is suitable and effective.</p> <p>Based on the test results, it is concluded that the UHF LDRCL equipment is qualified for operational deployment.</p>			
17. Key Words Low Density Radio Communication Link (LDRCL) UHF Radio System		18. Distribution Statement Document is on file at the Technical Center Library, Atlantic City International Airport, NJ 08405	
19. Security Classif. (of this report) Unclassified	20. Security Classif. (of this page) Unclassified	21. No. of Pages 40	22. Price

TABLE OF CONTENTS

	Page
EXECUTIVE SUMMARY	v
1. INTRODUCTION	1
1.1 Background	1
1.2 Purpose	1
1.3 Participants	1
1.4 Reference Documents	2
2. TEST APPROACH AND CONCEPT	4
3. TESTS AT FAA TECHNICAL CENTER	5
3.1 Operational User's Requirement Test Verification Requirements Traceability Matrix Tests (Appendix B)	5
3.2 Integration Test Matrix Tests (Appendix C)	6
4. OPERATIONAL TEST AND EVALUATION (OT&E) INTEGRATION TESTS AT KEY SITE	7
4.1 FAA-E-2853A Test Verification Requirements Traceability Matrix Tests (Appendix A)	7
4.2 Operational User's Requirement Test Verification Requirements Traceability Matrix Tests (Appendix B)	7
4.3 Integration Test Matrix Tests (Appendix C)	9
5. TEST RESULTS	9
5.1 Test Results at the FAA Technical Center	9
5.2 Operational Test and Evaluation (OT&E) Integration Test Results	10
6. CONCLUSIONS	
6.1 Test at the FAA Technical Center Conclusions	11
6.2 Operational Test and Evaluation (OT&E) Integration Test Conclusions	12
7. RECOMMENDATIONS	15
8. ACRONYMS AND ABBREVIATIONS	16

Accession For	
NTIS CRA&I	<input checked="" type="checkbox"/>
DTIC TAB	<input type="checkbox"/>
Unannounced	<input type="checkbox"/>
Justification	<i>per form 50</i>
By _____	
Distribution /	
Availability Codes	
Dist	Avail and/or Special
<i>A-1</i>	

APPENDIXES

- A - FAA-E-2853 Test Verification Requirements Traceability Matrix
- B - Operational User's Requirements Test Verification Requirements Traceability Matrix
- C - System Level/Integration Test Matrix

LIST OF ILLUSTRATIONS

Figure		Page
1	LDRCL UHF Subsystem Test Configuration	4
2	Typical System Block Diagram	5
3	Subsystem Block Diagram	6
4	Typical System Block Diagram	8
5	Subsystem Block Diagram	8

LIST OF TABLES

Table		Page
1	UHF System Equipment	4

EXECUTIVE SUMMARY

This test report describes the results of the Operational Test and Evaluation (OT&E) Integration and OT&E Operational testing performed at the Key Site on the Low Density Radio Communications Link (LDRCL) Ultra High Frequency (UHF) radio system installed between the Tonopah, Nevada, Air Route Surveillance Radar (ARSR) site and the Mina Remote Communications Air-to-Ground (RCAG) site. The OT&E effort was first conducted by Federal Aviation Administration (FAA) Technical Center personnel during the period of April 18 through 27, 1994. During this time period, Radio Frequency Interference (RFI) problems were encountered at the Mina RCAG site. After modifications were done to the system (i.e., the system was enclosed in a RFI/Electromagnetic Interference (EMI) cabinet) retesting was accomplished during the period of September 12 through 20, 1994.

The LDRCL is comprised of Nondevelopment Items (NDI) from the manufacturers listed below and integrated into the LDRCL system by Alcatel Communications and Government Systems of Richardson, Texas.

<u>ITEM</u>	<u>MANUFACTURER</u>
UHF Radio	Microwave Data Systems
Analog Multiplexer	Prism Systems
Battery/Charger	Power Conversion Products (PCP)
Remote Alarm	Westronic Systems Corp.

After the radio system was enclosed in a RFI cabinet, the radio system successfully passed all voice quality and data quality tests. In addition, when the system was integrated to a Codex 3600 modem from the Data Multiplexing Network (DMN) program, the system carried modem traffic at a rate of 19,200 bits per second (bps) for 53.2 hours with no bit errors. This is exceptional.

During testing at the Mina to Tonopah test site and the FAA Technical Center, it was found that this equipment did not meet all of the FAA-E-2853 specifications. It must be noted that this equipment is NDI and was not specifically designed to meet all of the LDRCL requirements. FAA Order 1810.6, "Policy for use of Nondevelopmental Items (NDI) in FAA Acquisitions" allows for the deployment of NDI equipment that does not meet all specification requirements, provided the equipment is operationally effective and suitable prior to commissioning of the subsystem.

The following areas are of concern:

1. The LDRCL equipment when equipped with Total Harmonic Distortion (THD) filters meets all of the requirements in Order 6950.2C for the critical Alternating Current (AC) power bus with the exception of the time requirement for the inrush current to return to 110 percent of its normal value.

2. Without THD filters, this equipment exceeds the THD requirement for the input current for equipment connected to the critical AC power bus.

3. A sensing circuit must be added to indicate when the Low Voltage Battery Disconnect (LVBD) has failed.

4. The UHF radio rack must be enclosed in a RFI/EMI enclosure at all sites.

In response to our concerns, the program office has agreed to install THD filters in all systems that will be connected to the critical power bus. A Engineering Change Proposal (ECP) is being prepared to resolve the LVBD failure problem. The program office will request a waiver for the inrush current time specification contained in Order 6950.2C so that LDRCL could be connected to the critical AC power bus.

Deployment is recommended with the conditions noted in section 7 of this report.

1. INTRODUCTION.

This report describes the results of the Low Density Radio Communications Link (LDRCL) Operational Test and Evaluation (OT&E) Integration and OT&E Operational testing performed at the key site, which was Mina and Tonopah, Nevada, and at the Federal Aviation Administration (FAA) Technical Center. The testing was performed in Nevada during the periods of April 18 through 27, 1994, and September 12 through 20, 1994. Additional testing was also performed at the FAA Technical Center to reverify test data or complete testing that could not be performed at the key site.

1.1 BACKGROUND.

The LDRCL procurement (Specification FAA-E-2853) will provide equipment to replace and upgrade existing links, leased systems, and new requirements for data communications for various National Airspace System (NAS) plan projects implemented in 1990 and beyond. Some of the current links that will be replaced are the short haul user access links and leased lines remoting circuits which currently provide connections between operational facilities such as Air Traffic Control Towers (ATCT), Terminal Radar Approach Control (TRACON), and remote sites such as Remote Communications Air-to-Ground (RCAG) Facility, Air Route Surveillance Radar (ARSR), Airport Surveillance Radar (ASR), etc.

1.2 PURPOSE.

The purpose of this report is to describe the OT&E Integration and OT&E Operational testing performed on the Ultra High Frequency (UHF) radio system and ACW-400A's reasons for recommending deployment of the system, at this time.

1.3 PARTICIPANTS.

<u>NAME</u>	<u>ORGANIZATION</u>
Wayne Bell	FAA Technical Center (Associate Program Manager for Test (APMT)
Michael R. Melillo	FAA Technical Center (Lead LDRCL project engineer) ACW-400A
Tom Smith	FAA Tonopah Site
Ted Gutierrez	FAA Mina Site
Jim Wilkinson	Sierra Nevada Sector
Steve Walker	Galaxy
Tuan Tran	FAA Technical Center
Chuck Cummings	Alcatel Networks Systems

1.4 REFERENCE DOCUMENTS

FAA Specifications

FAA-G-2100E Electronic Equipment, General Requirements
FAA-E-2853 Low Density Radio Communications Link
 Specification

FAA Standards

FAA-STD-024A Preparation of Test and Evaluation
 Documentation
FAA-STD-028 NAS Training Guidelines
FAA-STD-013/016/018 Quality Control Program Requirements
FAA-STD-021 Configuration Management
FAA-STD-020B Transient Protection, Grounding, Bonding
 and Shielding Requirements for Equipment

FAA Orders

1810.4B FAA NAS Test & Evaluation Program
1810.6 Policy for use of Nondevelopmental Items
 (NDI) in FAA Acquisitions
OAP 8200.1 U.S. Standard Flight Inspection Manual
6000.3 Maintenance of FAA Communications System
6950.2C Electrical Power Policy Implementation at
 National Airspace Facilities

NAS Documents

NAS-SS-1000 Vol. I NAS System Specification, Functional and
 Performance Requirements for the National
 Airspace System, General
NAS-SS-1000 Vol. III NAS System Specification, (Ground to Air
 Element)
NAS-SS-1000 Vol. I National Airspace System, system
 requirements Specification
NAS-MD-110 NAS Test Terms and Definitions
NAS-IR-44010001 Digital Interface Requirements

NAS-IR-44010002

Analog Interface Requirements

Other Documents.

ISO-7498

Open Systems Interconnection Standards
(Information Processing System)

EIA RS-195

Electrical and Mechanical Characteristics
of Microwave Relay System Antennas and
Passive Reflectors

PUB 62411

Accunet T1.5 Service Description and
Interface Specifications

Bell Labs

American Digital Hierarchy

International Radio
Consultative Committee:
CCIR REC 283-4
CCIR REC 275-3

Radio-Frequency Channel Arrangements for
Radio Relay Systems

Pre-Emphasis Characteristics for Frequency
Modulation Radio-Relay Systems for
Telephony Using FM Multiplexing

2. TEST APPROACH AND CONCEPT.

The test approach and concept was to evaluate the LDRCL equipment in accordance with the "Low Density Radio Communications Link (LDRCL) Master Test Plan" and the "Low Density Radio Communications Link (LDRCL) Operational Test and Evaluation (OT&E) Integration and Operational Test Plan." This involved testing the requirements contained in the LDRCL Specification FAA-E-2853 associated with the UHF radio system which are contained in appendix A of this document, the NAS-SS-1000, Operational User's Requirements which are contained in appendix B of this document, and requirements contained in the Integration Test Matrix contained in appendix C of this document.

The LDRCL subsystem used for the OT&E Integration and OT&E Operational tests was comprised of terminal equipment at the Mina, Nevada RCAG site and the Tonopah, Nevada ARSR site. A block diagram of the test configuration is provided in figure 1 and a list of the equipment that was tested in Mina and Tonopah, Nevada, and/or the FAA Technical Center is listed in table 1.

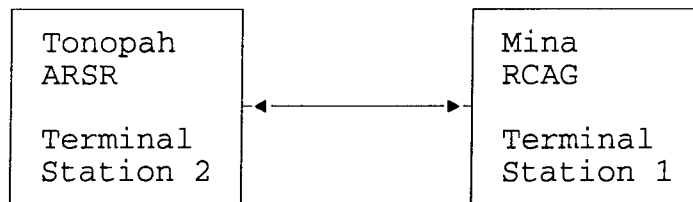

FIGURE 1. LDRCL UHF SUBSYSTEM TEST CONFIGURATION

TABLE 1. UHF System Equipment

Equipment	Terminal 1	Terminal 2
Microwave Data Systems MD-960 Radio	Qty 1	Qty 1
Prism Systems Analog Multiplexer	Qty 1	Qty 1
Westronic Alarm System	Qty 1	Qty 1
202T Modem for above	Qty 1	N/A
12-channel Jackfields	Qty 1	Qty 1
Attenuator Panel	Qty 1	Qty 1
Battery Charger System	Qty 1	Qty 1
4-Wire E&M VF cards	Qty 12	Qty 12

3. TESTS AT THE FAA TECHNICAL CENTER.

The testing done at the FAA Technical Center was used to verify requirements that could not be tested in the field and reverify data collected in the field. The testing that was accomplished at the FAA Technical Center is listed in the following paragraphs.

3.1 OPERATIONAL USER'S REQUIREMENT TEST VERIFICATION REQUIREMENTS TRACEABILITY MATRIX (TVRTM) TESTS (Appendix B).

3.1.1 SYSTEM LEVEL TESTS.

These tests were run to evaluate that the LDRCL equipment can suitably and effectively interface with other NAS subsystems. Figure 2 is a typical system level block diagram of the test configuration used. The Transmission Impairment Measuring Sets (TIMS) simulate users.

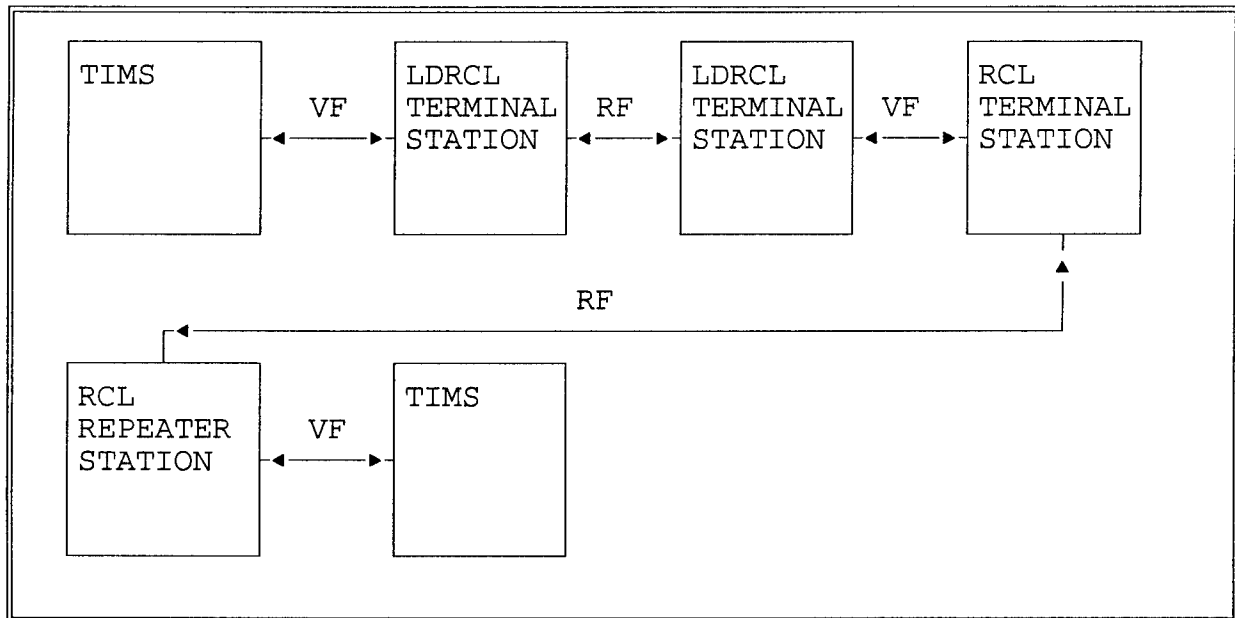

FIGURE 2. TYPICAL SYSTEM BLOCK DIAGRAM

The following system level tests were run at the FAA Technical Center:

- a. Audio Quality Test LDRCL to Radio Communications Link (RCL). (TVRTM test # 1).
- b. LDRCL/RCL critical circuit interface test. (TVRTM # 9).

3.1.2 SUBSYSTEM LEVEL TESTS.

These tests were run to see that the LDRCL subsystem met certain criteria established by the Program Office in the Master Test Plan. (MTP). Figure 3 is a typical block diagram for a subsystem level test.

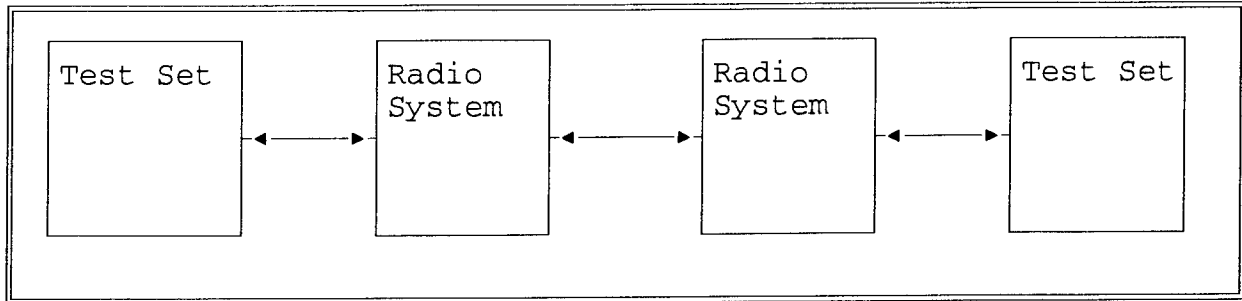

FIGURE 3. SUBSYSTEM BLOCK DIAGRAM

The following subsystem level tests were run at the FAA Technical Center:

- a. Crosstalk. (TVRTM test #2).
- b. Alarms indication test during transients. (TVRTM test #3).
- c. Maintainability Test. (TVRTM test #4).
- d. LRU removal/replacement Test. (TVRTM test #5).
- e. LDRCL Electromagnetic Interference (EMI)/Radio Frequency Interference (RFI) Test. (TVRTM test #11).

3.2 INTEGRATION TEST MATRIX TESTS (Appendix C).

3.2.1 SYSTEM LEVEL TESTS.

These tests were run to evaluate that the LDRCL equipment can suitably and effectively interface with other NAS subsystems. See figure 2 for a typical system level block diagram of the test configuration used. The TIMS simulate users.

The following system level tests were run at the FAA Technical Center:

- a. Modem to LDRCL Test.
- b. Automated Network Monitoring System (ANMS) to LDRCL interface Test.
- c. Total Harmonic Distortion Test.
- d. Inrush Current Test.

3.2.2 SUBSYSTEM LEVEL TESTS.

These tests were run to see that the LDRCL subsystem met certain criteria established by the FAA Technical Center in the LDRCL OT&E Integration and Operational Test Plan. Figure 3 is a typical block diagram for a subsystem level test.

The following subsystem level tests were run at the FAA Technical Center:

- a. Envelope Delay Distortion Test.
- b. Frequency Translation and Level Test.
- c. Channel Amplitude Frequency Response Test.
- d. Phase and Jitter Test.
- e. Voice Frequency Performance Test.
- f. Degraded Operations Test.
- g. Silent Failure Test.

4. OPERATIONAL TEST AND EVALUATION (OT&E) INTEGRATION TESTS AT KEY SITE.

Testing done at the key site is used to verify that the new subsystem can be successfully installed, and operated at a NAS operational site. These tests were run to evaluate that the LDRCL equipment can suitably and effectively interface with other NAS subsystems.

4.1 FAA-E-2853A, TEST VERIFICATION REQUIREMENTS TRACEABILITY MATRIX TESTS (Appendix A).

These tests were run by the contractor during Factory Acceptance Testing (FAT) and/or Site Acceptance Testing and witnessed by the FAA Technical Center personnel. These tests were run to evaluate how well the LDRCL equipment met the LDRCL specification.

4.2 OPERATIONAL USER'S REQUIREMENT TEST VERIFICATION REQUIREMENTS TRACEABILITY MATRIX TESTS (Appendix B).

4.2.1 SYSTEM LEVEL TESTS.

These tests were run to evaluate that the LDRCL equipment can suitably and effectively interface with other NAS subsystems. Figure 4 is a typical system level block diagram of the test configuration used. The Fireberd provides digital data which simulates a user such as radar. The Modem is a Codex 3600 which represents part of the Data Multiplexing Network (DMN) Subsystem and helps simulate the necessary connections for the LDRCL subsystem to DMN subsystem interface.

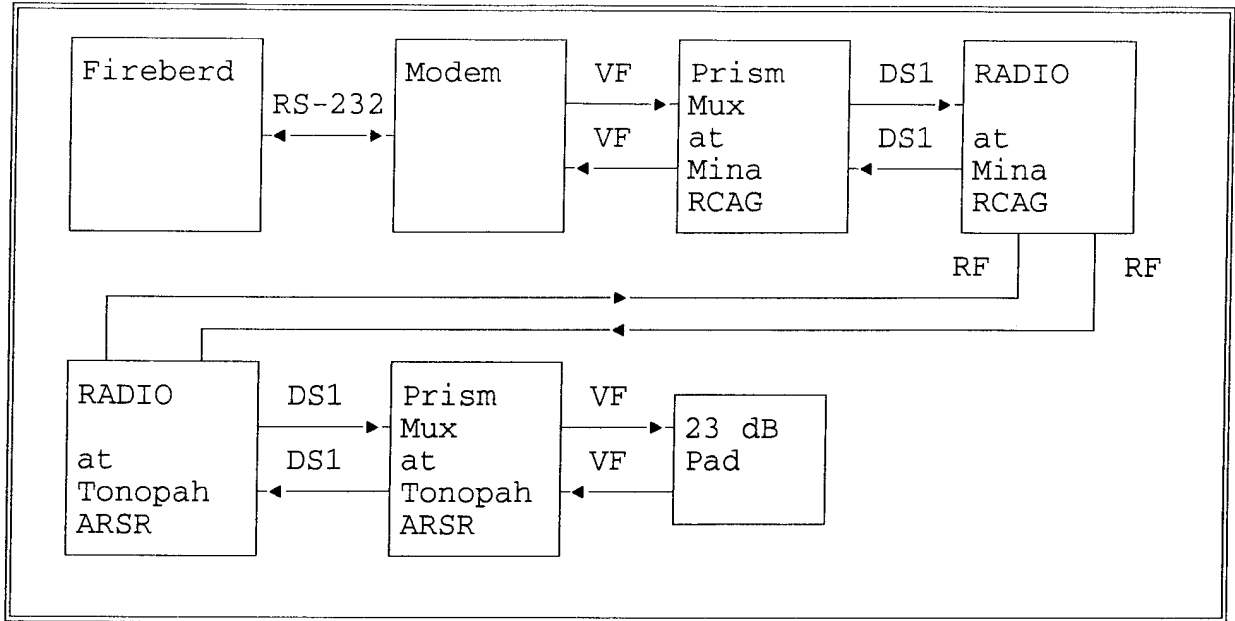

FIGURE 4. TYPICAL SYSTEM BLOCK DIAGRAM

The following system level test was run at the key site:

- a. AC power test. (TVRTM test #7).

4.2.2 SUBSYSTEM LEVEL TESTS.

These tests were run to see that the LDRCL subsystem met certain criteria established by the FAA Technical Center in the LDRCL OT&E Integration and Operational Test Plan. See figure 5 for a typical block diagram for a subsystem level test.

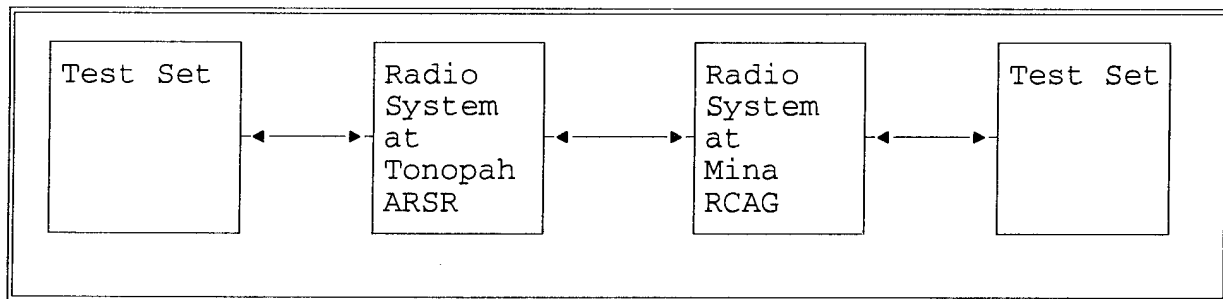

FIGURE 5. SUBSYSTEM BLOCK DIAGRAM

The following subsystem level tests were run at the key site:

- a. Crosstalk. (TVRTM test #2).
- b. Maintainability Test. (TVRTM test #4).
- c. LRU Removal/Replacement Test. (TVRTM test #5).

4.3 INTEGRATION TEST MATRIX TESTS (Appendix C).

4.3.1 SYSTEM LEVEL TESTS.

These tests were run to evaluate that the LDRCL equipment can suitably and effectively interface with other NAS subsystems. See figure 4 for a typical system level block diagram of the test configuration used. The Fireberd provides digital data which simulates a user such as radar, The Modem is a Codex 3600 which represents part of the DMN Subsystem and helps simulate the necessary connections for the LDRCL subsystem to DMN subsystem interface.

The following system level tests were run at the key site:

- a. Modem to LDRCL Test.
- b. Total Harmonic Distortion Test.

4.3.2 SUBSYSTEM LEVEL TESTS.

These tests were run to see that the LDRCL subsystem met certain criteria established by the program office in the MTP. Figure 5 is a typical block diagram for a subsystem level test.

The following subsystem level tests were run at the key site:

- a. Envelope Delay Distortion Test.
- b. Frequency Translation and Level Test.
- c. Channel Amplitude Frequency Response Test.
- d. Phase and Jitter Test.
- e. Voice Frequency Performance Test.
- f. Silent Failure Test.

5. TEST RESULTS.

5.1 TEST RESULTS AT THE FAA TECHNICAL CENTER.

5.1.1 OPERATIONAL USER'S REQUIREMENTS TEST VERIFICATION REQUIREMENTS TRACEABILITY MATRIX TEST RESULTS (Appendix B).

Eleven test requirements are specified in the FAA MTP Operational User's Requirements TVRTM also contained in appendix B of this document. Out of these, seven were requirements to be tested by the FAA Technical Center and four were requirements to be tested by the shakedown test team. Out of the seven tests tested at the FAA Technical Center, six passed and one failed. The one that failed

does affect the operational performance of the radio and is considered a major deficiency. The test that failed was the EMI/RFI test. The equipment was affected by a radiated field between 40 KiloHertz (KHz) and 200 MegaHertz (MHz) at 15 volts per meter. For more details see the notes associated with appendix B of this report.

5.1.2 SYSTEM LEVEL REQUIREMENTS VERIFICATION TEST RESULTS (Appendix C).

Eleven test requirements are listed in the system level/Integration Test Matrix contained in appendix C of this report. Out of the 11 tests, 10 tests passed completely at the FAA Technical Center. One did not pass. It was the Inrush Current Test. This deficiency is characterized as a minor deficiency. For more details see the notes associated with the tests in appendix C.

5.2 OPERATIONAL TEST AND EVALUATION (OT&E) INTEGRATION TEST RESULTS.

5.2.1 FAA-E-2853A, TEST VERIFICATION REQUIREMENTS TRACEABILITY MATRIX TEST RESULTS (Appendix A).

Sixty-five subsystem level test requirements are specified for the UHF system (appendix A). Forty-nine passed, 9 failed, and 7 could not be completely verified. (For more details, see the notes associated with appendix A of this report.) Those tests that did fail, failed because the equipment selected was NDI equipment which did not entirely meet the LDRCL specifications. The failed tests were considered as noncritical to the actual performance of the radio system and are considered minor deficiencies which do not affect the operational performance of the radio system. Of the seven tests that were not completely verified, three will be verified by the shakedown team, one is verified during site frequency assignments, three will be verified at a later date when the equipment becomes available and one needs to be verified as soon as possible. The one that needs to be verified as soon as possible is the ambient temperature requirement. Since the equipment is now enclosed in an EMI cabinet, temperature measurements should be made to ensure that the radio still can meet the requirements contained in the specification. This deficiency is characterized as a Moderate deficiency.

5.2.2 OPERATIONAL USER'S REQUIREMENTS TEST VERIFICATION REQUIREMENTS TRACEABILITY MATRIX TEST RESULTS (Appendix B).

At the OT&E key site, there were 11 Operational User's Requirements Tests (appendix B) which could be performed on the UHF radio system. Three requirements were successfully verified at the key site. Two tests could not to be verified at the key site as the system was not connected into the RCL as required. Four tests will be verified during OT&E Shakedown tests. Two tests could not be

performed at key site and were performed at the FAA Technical Center. See the section titled "Test Results at the FAA Technical Center."

5.2.3 INTEGRATION TEST MATRIX TEST RESULTS (Appendix C).

Eleven test requirements are listed in the system level/Integration Test Matrix contained in appendix C of this report. Out of the 11 tests, 8 tests were tested at the key site. The other three were tested at the FAA Technical Center due to the lack of equipment at the key site. i.e., no RCL ANMS. Of the eight tests completed at the key site, six tests passed completely. One test failed the critical bus criteria for Total Harmonic Distortion (THD); and one test, the silent failure test, passed at the key site with comments. For more details, see the notes associated with the tests in appendix C.

6. CONCLUSIONS.

6.1 TEST AT THE FAA TECHNICAL CENTER CONCLUSIONS.

6.1.1 OPERATIONAL USER'S REQUIREMENTS TEST VERIFICATION REQUIREMENTS TRACEABILITY MATRIX TEST CONCLUSIONS (Appendix B).

Based upon the test results obtained, the conclusion for the requirements that failed at the FAA Technical Center are as follows:

a. Verify that the Low Density Radio Communications Link (LDRCL) is not affected by electromagnetic radiation and does not affect other FAA systems with Electromagnetic Interference (EMI).

This requirement was not met. The Ultra High Frequency (UHF) radio (MDS-960) and the Westronic Alarm System (WS-2000) as configured at the FAA Technical Center (i.e., with no EMI cabinet), experienced interference problems in the presence of a radiated field. This problem is not satisfactory and should be corrected.

6.1.2 INTEGRATION TEST MATRIX TEST CONCLUSIONS (Appendix C).

Based upon the test results obtained, the conclusion for the requirements that failed at the FAA Technical Center are as follows:

a. Inrush Current.

The UHF radio system at the FAA Technical Center does not meet the critical bus criteria contained in Order 6950.2C. Specifically, the time it takes for the inrush current to return to 110 percent of the normal value. The requirement is 8 milliseconds (ms). LDRCL's value is approximately 350 to 400 ms. This is not satisfactory for critical Alternating Current (AC) bus

installations and should be corrected.

The UHF radio does meet the inrush requirements contained in specification FAA-G-2100F. "Electronic Equipment, General Requirements Specification." This is satisfactory for noncritical bus installations.

6.2 OPERATIONAL TEST AND EVALUATION (OT&E) INTEGRATION TEST CONCLUSIONS.

6.2.1 FAA-E-2853A TEST VERIFICATION REQUIREMENTS TRACEABILITY MATRIX TEST CONCLUSIONS (Appendix A).

Based upon the test results obtained, the conclusion for the requirements that failed are as follows:

a. Specification Paragraph 3.1.2.2, Ambient Temperature. Unless otherwise specified, the system shall operate within the specification requirements over the following ambient temperatures 0° C to +50° C.

Although this requirement did not really fail, it is still of concern as the radio's specification is for the radio operating in an open rack. The UHF radio is now enclosed in an EMI cabinet with ventilation holes only at the top of the cabinet. The UHF radio manual states that if the rack cabinet contains any other heat generating equipment, be sure to provide additional air circulation within and through the cabinet to keep the equipment as cool as practical. The UHF radio system as installed in Mina in the EMI cabinet has no free flow of air through the cabinet. It only has the ventilation holes on the top. This may or may not be satisfactory. Additional temperature measurements, along with an analysis on the heat buildup inside the cabinet or air holes on the lower part of the door to provide air circulation, are required.

b. Specification Paragraph 3.1.2.11, Cooling. Equipment will be designed for convection cooling of most of the systems or subparts of a system. Forced air cooling may be allowed to extend the service life of high heat generating subsystems. Air flow shall be monitored and alarmed to detect failure of air flow.

The radio itself contains a fan to move the heat from within the radio to outside the radio. This fan does not have a air flow monitor or alarm to indicate the failure of air flow. According to the manufacturer of the radio the radio, will operate correctly without the fan. The fan was added to extend the service life of some of the modules. Being that this is a Commercial-Off-The-Shelf (COTS) procurement, this is acceptable.

c. Specification Paragraph 3.2.1, General. All performance requirements specified shall be met when the equipment is assembled into a system in the configuration that will be installed for field

operation.

This requirement was not met. This NDI equipment does not completely meet all the requirements specified. This is still satisfactory as the equipment will accomplish its mission in the National Airspace System (NAS).

d. Specification Paragraph 3.2.3, Equipment Configuration. Pilot sensing shall be utilized for detecting analog system failures.

The equipment does not have a pilot to sense analog failures. The equipment switches on the signal to noise level which is adjustable. This is satisfactory as switching on signal to noise is just as good as switching on a loss of pilot.

e. Specification 3.2.8, Receiver/Combiner Switch. The combiner/switch shall not cause interruptions or transients which may degrade the signal.

The radio was not designed with hitless switching; therefore, during a transmitter switch, the radio will experience a loss of signal. This will only happen during a catastrophic failure of the current operating transmitter channel. This is satisfactory as the mean time between failures for the transmitter module is 501,072 hours. This event should rarely happen.

f. Specification Paragraph 3.3.14.11.6 Channel Noise Looped.

- a. 13 dBRNC0 maximum per idle channel
- b. 16 dBRNC0 maximum per loaded channel

The Prism Multiplexer does not meet the loaded channel specification listed above. This is alright as this test is run with the multiplexer looped back on itself. (i.e., multiplexer only). The radio receiver noise is a minimum 10 decibels (dB) greater than the noise in the multiplexer and when connected to the multiplexer, the receiver's noise completely masks the multiplexer noise floor. Since this happens, the noise due to the multiplexer becomes insignificant and does not affect the operation of the system. Therefore, although the multiplexer is not specification compliant, it is still acceptable.

g. Specification Paragraph 3.8.1.1, Battery Protection. A Low Voltage Load Disconnect (LVLD) unit shall be provided that is capable of removing the batteries from the load when a predetermined cell voltage limit has been reached thus preventing damage to the battery bank due to excessive cellular discharge (normally 1.75 volts per cell). The LVLD shall also be equipped for remote control operation that permits control via the LDRCL alarm monitoring and control subsystem. A feature shall be incorporated that allows local and remote override of the switch function. Reset of the switch shall be automatic when the battery

compliment recharges to normal operational voltage.

The automatic reset of switch after the batteries are charged to normal operating voltages is not incorporated. Switch resets once A/C power is restored to power supplies. This is satisfactory as most Nondevelopmental Item (NDI) radio systems are designed this way.

h. Specification Paragraph 3.8.6, Grounding System. The grounding system shall be in accordance with FAA-STD-20B.

The tower installed at the site was not installed in accordance with FAA-STD-B. The tower had one air terminal and one down conductor. The tower should of had two air terminals and two down conductors as per the specification. This is not acceptable and should be corrected.

i. Specification Paragraph 4.3, System Tests. The contractor shall conduct on the first system of each type ordered, factory system end-to-end performance acceptance tests, i.e., the tests required to demonstrate to the government that the system meets the requirements as specified. The tests shall demonstrate that all equipment is operating within the normal operating tolerances as stated in the equipment documentation.

The equipment does not meet all the requirements as specified because it is NDI equipment. All the specification requirements that are not met will not affect the operational performance of the system. For NDI equipment this is satisfactory.

j. Specification Paragraph 4.4, Field System Tests. When site installation of a microwave system is ordered by the government, the contractor shall conduct field system end-to-end performance acceptance tests, i.e., the tests required to demonstrate to the government that the system is installed and operating in accordance with the requirements as specified. The tests shall demonstrate that all equipment is operating within the normal operating tolerances as stated in the equipment documentation.

The equipment does not meet all the requirements as specified because it is NDI equipment. All the specification requirements that are not met will not affect the operational performance of the system. For NDI equipment this is satisfactory.

6.2.2 OPERATIONAL USER'S REQUIREMENTS TEST VERIFICATION REQUIREMENTS TRACEABILITY MATRIX TEST CONCLUSIONS (Appendix B).

After the radio was installed in an EMI cabinet, all the tests associated with this matrix, that could be tested at the key site, were successfully completed. For additional conclusions on testing that could not be completed in the field, see section 6.1.1.

6.2.3 INTEGRATION TEST MATRIX TEST CONCLUSIONS (Appendix C).

After the radio was installed in an EMI cabinet, all the tests associated with this matrix that could be tested at the key site were successfully completed. For additional conclusions on testing that could not be completed in the field, see section 6.1.2.

7. RECOMMENDATIONS.

Based on all test results, it is recommended that the Ultra High Frequency (UHF) radio system be deployed at this time under the following conditions:

- a. The following two items have not been tested and should not be deployed until successful Operational Test and Evaluation (OT&E) testing has been performed.
 1. Seismic Rack.
 2. Optional high powered amplifier.
- b. The UHF radio must be installed in a Radio Frequency Interference (RFI)/Electromagnetic Interference (EMI) cabinet at all locations.
- c. A switch or some kind of sensing circuit will be added to the Low Voltage Battery Disconnect relay to indicate when the relay has failed. Also an alarm should indicate on the Westronics alarm system.
- d. For critical Alternating Current (AC) power bus installations, Total Harmonic Distortion (THD) filters will be installed and a waiver must be granted that releases Low Density Radio Communications Link (LDRCL) from the requirement that the duration of the inrush current shall not exceed 8 milliseconds (ms). (Return to 110 percent of its normal value.) LDRCL exceeds this requirement. For noncritical AC power bus installations, THD filters are not required but the installation of the filters would be beneficial to other equipment connected to the bus. The regions can decide for themselves if they want to install THD filters at these locations.
- e. All voice frequency lines between the attenuator panel and the demarcation blocks (66 blocks) should be shielded.
- f. The attenuator panels should be wired like they currently are at the Mina and Tonopah, Nevada sites. i.e., one voice frequency (VF) channel of the Prism Multiplexer goes to one circuit card in the attenuator panel.
- g. A waiver should be granted to Alcatel for the loaded noise looped requirement contained in the specification. Also, the

test should be deleted from the site acceptance test procedure.

- h. The order wire buzzer should be relocated so that it is outside the EMI cabinet. This way it can be heard.
- i. Either air vents need to be added to the bottom of the doors of the EMI cabinet with proper EMI shielding to help with air flow through the cabinet or someone needs to run a test that proves that the radio will still function when the ambient air temperature reaches 50°C.

8. ACRONYMS AND ABBREVIATIONS

AC	Alternating Current
ANMS	Automated Network Monitoring System
APMT	Appointed Program Manager for Test
ARSR	Air Route Surveillance Radar
ARTCC	Air Route Traffic Control Center
ASR	Airport Surveillance Radar
ATCT	Air Traffic Control Tower
BER	Bit Error Rate
COTS	Commercial Off-the-Shelf
dB	Decibel
DMN	Data Multiplexing Network
E&M	Ear and Mouth
ECP	Engineering Change Proposal
EMI	Electromagnetic Interference
E/R	Extended Range
FAA	Federal Aviation Administration
KHz	KiloHertz
LDRCL	Low Density Radio Communication Link
LRU	Line Replaceable Unit
LVBD	Low Voltage Battery Disconnect
LVLDD	Low Voltage Load Disconnect
MHz	MegaHertz
ms	Milliseconds
MTP	Master Test Plan
NAS	National Airspace System
NDI	Nondevelopmental Item
OT&E	Operational Test and Evaluation
PCP	Power Conversion Products
RCAG	Remote Communications Air to Ground
RCL	Radio Communications Link
RCLR	Radio Communications Link Repeater
RFI	Radio Frequency Interference
TIMS	Transmission Impairment Measurement Set
THD	Total Harmonic Distortion
TOR	Technical Onsite Representative
TRACON	Terminal Radar Approach Control
TVRTM	Test Verification Requirements Matrix

UHF
VF

Ultra High Frequency
Voice Frequency

Appendix A

FAA-E-2853A

Test Verification Requirements Traceability Matrix (TVRTM)

Paragraph No.	Requirement Description	Verification Method		Test Location		Pass/ Fail	NOTE
		Subsystem Level	System Level	FAT	Key Site		
3.1.2.1	Duty Cycle	A	X	*	N/A	P	
3.1.2.2	Ambient Temperature	A	X	N/T	N/A	N/V	1
3.1.2.3	Relative Humidity	A	X	*	N/A	P	
3.1.2.4	Power	A	X	*	N/A	P	
3.1.2.5	Racks	I	X	*	N/A	N/V	2
3.1.2.7	Solid State	I	I	*	N/T	P	
3.1.2.8	Accessibility	I	I	*	N/T	P	
3.1.2.9	Transient Protection	I	I	N/T	*	P	
3.1.2.10	Finishes	I	I	*	N/T	P	
3.1.2.11	Cooling	I	I	*	N/T	F	3

Verification Method: T=Test, D=Demonstration, A=Analysis, I=Inspection, X=Not Applicable
Notes:

* = Verification Method Conducted.

P = Passed, Meets requirement without comment, N/T = Not Tested, N/A = Not Applicable,
N/V = Not completely verified.

1 = The documentation for this radio indicates that the equipment can meet the requirements contained in the specification but this was before the radio was installed in a closed cabinet.

2 = Paragraph Passed with the exception of the seismic rack which was not available.

3 = Radio utilizes a Fan to extend the service life of the equipment. There is no alarm to monitor the air flow as per the specification.

Paragraph No.	Requirement Description	Verification Method			Test Location		Pass/ Fail	N O T E
		Subsystem Level	System Level	FAT	Key Site			
3.1.2.12	Interchangeability	A	X	*	N/A		P	
3.1.2.13	Special Equipment	I	I	*	N/T		P	
3.2.1	General	T	X	*	N/A		F	4
3.2.2.1	Spectrum Design Req'ments	X	I	N/A	N/T		N/V	5
3.2.2.2	Frequency and Antenna Polarization	D	I	*	*		P	
3.2.3	Equipment Configuration	T	T	*	*		F	6
3.2.4	Radio Frequency Coupler	I	I	*	N/T		P	
3.2.5	Radio Freq Connectors	I	I	*	N/T		P	
3.2.6	Antennas	X	I	N/A	*		P	
3.2.7	Transmission Lines	X	I	N/A	*		P	

Verification Method: T=Test, D=Demonstration, A=Analysis, I=Inspection, X=Not Applicable
Notes:

* = Verification Method Conducted.

P = Passed, Meets requirement without comment, N/T = Not Tested, N/A = Not Applicable,

N/V = Not completely Verified.

4 = All performance requirements were not met.

5 = Frequencies are ordered by the Program Office under the advice of the FAA Frequency Management section.

6 = Analog failure is initiated by Signal to Noise ratio not pilot sensing as specified.

Paragraph No.	Requirement Description	Verification Method		Test Location		N O T E
		Subsystem Level	System Level	FAT	Key Site	
3.2.8	Receiver/Combiner Switch	T	T	*	*	F 7
3.2.10.1	General	D	D	*	N/T	P
3.2.10.2	Auxiliary Functions	D	D	*	N/T	P
3.2.11	Jackfields	I	I	*	N/T	P
3.2.12	RF Splitter	I	I	*	N/T	P
3.2.13	Line Conditioning Equipment	T	T	N/T	*	P
3.3.14.11	Analog Multiplexing Equipment	T	T	*	*	P
3.3.14.11.1	Level Stability	T	T	*	*	P
3.3.14.11.2	Channel Amplitude Frequency Response	T	T	*	*	P
3.3.14.11.3	Channel Envelope Delay Distortion	T	T	*	*	P

Verification Method: T=Test, D=Demonstration, A=Analysis, I=Inspection, X=Not Applicable
Notes:

* = Verification Method Conducted.

P = Passed, Meets requirement without comment, N/T = Not Tested, N/A = Not Applicable,
N/V = Not completely Verified.

7 = Transients are produced during a transmitter switch.

Paragraph No.	Requirement Description	Verification Method		Test Location		Pass/ Fail	NOTE
		Subsystem Level	System Level	FAT	Key Site		
3.3.14.11.4	Four Wire Voice Frequency Interface	T	T	*	*	P	
3.3.14.11.5	Baseband Interface	T	T	*	N/T	P	
3.3.14.11.6	Channel Noise Looped	T	T	*	*	F	8
3.3.14.11.7	Phase Jitter	T	T	*	*	P	
3.3.14.11.8	End to End Frequency Translation Error	T	T	*	*	P	
3.4.1	Frequencies of Operation for UHF Equipment	T	X	*	N/A	P	
3.4.2	RF Power	T	T	*	*	P	
3.4.3	Transmitter Frequency Stability	T	T	*	*	P	
3.4.4	Receiver Sensitivity	T	T	*	*	P	
3.4.5	Channel Capacity	T	T	*	N/T	P	

Verification Method: T=Test, D=Demonstration, A=Analysis, I=Inspection, X=Not Applicable
Notes:

* = Verification Method Conducted.

P = Passed, Meets requirement without comment, N/T = Not Tested, N/A = Not Applicable,
N/V = Not completely Verified.

8 = Channel noise looped does not meet the 16 dBrnC0 requirement for a loaded system. The measured results varied between 13 and 19 dBrnC0.

Paragraph No.	Requirement Description	Verification Method			Test Location		Pass/ Fail	N O T E
		Subsystem Level	System Level	FAT	Key Site			
3.4.7	Multichannel UHF Link	T	T	*	*	N/V	9	
3.4.7.1	Multiplexer Equipment	T	T	*	*	P		
3.6	Remote Monitoring/Sensing	I	I	*	*	P		
3.6.1	Reported Alarms	T	T	*	*	P		
3.6.2	Alarm Indication	T	T	*	*	P		
3.6.2.1	Alarm Interfaces with RCL system (TABS)	T	T	N/T	*	P		
3.6.3	Remote Controls	T	T	*	*	P		
3.7.1	Reliability	A	X	*	N/A	P		
3.7.2	Maintainability	A	X	*	N/A	P		
3.7.3	Availability	A	X	*	N/A	P		
3.8.1	Batteries	X	I	N/A	*	P		

Verification Method: T=Test, D=Demonstration, A=Analysis, I=Inspection, X=Not Applicable
Notes:

* = Verification Method Conducted.

P = Passed, Meets requirement without comment, N/T = Not Tested, N/A = Not Applicable,

N/V = Not completely Verified.

9 = Optional Power Amplifier not tested. The rest of the paragraph passes.

Paragraph No.	Requirement Description	Verification Method		Test Location			NOTE
		Subsystem Level	System Level	FAT	Key Site	Pass/Fail	
3.8.1.1	Battery Protection	T	T	N/T	*	F	10
3.8.2	Battery Charger	T	X	N/T	*	P	
3.8.2.1	Optional Battery Charger	X	T	N/A	*	P	
3.8.4	Towers	X	D	N/A	N/T	N/V	11
3.8.4.1	Obstruction Lights	A	I	*	N/T	P	
3.8.5	Antenna Mounts	A	I	*	N/T	P	
3.8.6	Grounding System	X	T	N/A	*	F	12
3.9.2	Instruction Books	X	I	N/A	N/T	N/V	13
3.10.2.1	Site Spares	X	I	N/A	N/T	N/V	13

Verification Method: T=Test, D=Demonstration, A=Analysis, I=Inspection, X=Not Applicable
Notes:

* = Verification Method Conducted.

P = Passed, Meets requirement without comment, N/T = Not Tested, N/A = Not Applicable,
N/V = Not completely Verified.

10 = The system was not configured with a LVBD, therefore this function could not be tested.
The auto reset circuit does not function as per the specification.

11 = There were no new towers at this key site. This requirement did successfully pass at
the first key site for the 1.8 GHz digital radio.

12 = The tower was not installed as per FAA-STD-024B. It was missing the second air terminal
and second down conductor.

13 = Not tested by ACW, AOS responsibility.

Paragraph No.	Requirement Description	Verification Method		Test Location		N O T E	
		Subsystem Level	System Level	FAT	Key Site		Pass/Fail
3.10.2.2	Depot Parts - Peculiar	X	I	N/A	N/T	N/V	13
4.3	System Tests	T	X	*	N/A	F	14
4.4	Field System Tests	X	T	N/A	*	F	14
5.0	Preparation for Delivery	I	X	*	N/A	P	
6.0	Preparation for Installation	X	I	N/A	*	P	

Verification Method: T=Test, D=Demonstration, A=Analysis, I=Inspection, X=Not Applicable
Notes:

* = Verification Method Conducted.

P = Passed, Meets requirement without comment, N/T = Not Tested, N/A = Not Applicable,

N/V = Not Completely Verified.

14 = The equipment does not meet all the requirements as specified, and does not operate within the normal operating tolerances as states in the equipment documentation.

Appendix B

Operational User's Requirement

Test Verification Requirements Traceability Matrix (TVRTM)

Requirement Description	Verification Method		Test Location		Notes
	Integration Level	Shakedown Level	FAATC	Key Site	
1. Verify that the audio quality of any circuit does not become degraded, and that there is no detectable change in voice quality/level as the LDRCL is accessed by signals to and from the RCL links.	D	X	*	N/T	P
2. Verify that crosstalk is not detectable under maximum loading of the LDRCL paths.	D	X	*	*	P
3. Verify that the alarm indicators function properly under electrical transients caused by commercial power changes.	D	X	*	N/T	P
4. Verify that after system failure in LDRCL, the entire path can be restored in 30 minutes. (Maintainability).	D	X	*	*	P
5. Verify that the removal/replacement of any line replaceable unit (LRU) does not affect the normal operation of the LDRCL.	D	X	*	*	P

Verification Method: T=Test, D=Demonstration, A=Analysis, I=Inspection, X=Not Applicable
Notes:

* = Verification Method Conducted

P = Passed, Meets requirement without comment, N/T = Not Tested, N/A = Not Applicable

Requirement Description	Verification Method		Test Location		Notes
	Integration Level	Shakedown Level	FAATC	Key Site	
6. Verify that adequate spare parts exist at each site to support urgent repairs to the LDRCL.	X	D	N/T	*	1
7. Verify that the LDRCL can be integrated with existing FAA facility power and environmental systems with little or no impact on normal operations.	X	D	N/T	*	1
8. Verify that the LDRCL can protect itself from the effects of power outages, fluctuations and harmful transients.	X	D	N/T	*	1
9. Verify that the LDRCL, in the process of accessing the circuits of the RCL paths, will not take down any other specified, critical circuits that would not otherwise have been affected by the problem.	D	X	*	N/T	P

Verification Method: T=Test, D=Demonstration, A=Analysis, I=Inspection, X=Not Applicable
Notes:

* = Verification Method Conducted

P = Passed, Meets requirement without comment, N/T = Not Tested, N/A = Not Applicable

1 = AOS-200 responsibility, see Shakedown Report

Requirement Description	Verification Method		Test Location		Notes
	Integration Level	Shakedown Level	FAATC	Key Site	
10. Verify by random sampling the mechanical and electrical interchangeability among assemblies, subassemblies, and LRUs that are supposed to be identical.	X	D	N/T	*	2
11. Verify that the LDRCL is not affected by electromagnetic radiation and does not affect other FAA systems with EMI	D/T	X	*	*	3

Verification Method: T=Test, D=Demonstration, A=Analysis, I=Inspection, X=Not Applicable
Notes:

* = Verification Method Conducted

P = Passed, Meets requirement without comment, N/T = Not Tested, N/A = Not Applicable

2 = AOS-200 responsibility, see shakedown report.

3 = During testing at the FAA Technical Center, Both the UHF radio and the Westronic Alarm System experienced interference problems below 200 MHz. A report was generated but no real action was taken on the problem. Upon installation of the UHF radio system at the Mina RCAG site, the UHF radio experienced interference from the VHF radio operating at 125 MHz. A change was then made that installed the radio system minus the battery charger system into an EMI cabinet. At the Mina site, no interference problems were experienced after the radio system minus the charger system was installed in the EMI cabinet.

Appendix C

Integration Test Verification
Requirements Test Matrix

Test Description	Verification Method		Test Location		Notes
	System Level	Integration Level	FAATC	Key Site	
1. Envelope Delay Distortion Test	T	X	*	*	P
2. Frequency Translation and Level Test	T	X	*	*	P
3. Channel Amplitude Frequency Response Test	T	X	*	*	P
4. Phase and Jitter Test	T	X	*	*	P
5. Voice Frequency Performance Test	T	X	*	*	P
6. Modem to LDRCL Test	X	T	*	*	P
7. ANMS to LDRCL interface Test	X	T	*	N/T	P
8. Degraded Operations Test	X	T	*	N/T	P
9. Total Harmonic Distortion Test	X	T	*	*	1

Verification Method: T=Test, D=Demonstration, A=Analysis, I=Inspection, X=Not Applicable
Notes:

* = Verification Method Conducted

P = Passed, Meets requirement without comment, N/T = Not Tested, N/A = Not Applicable

1 = With Harmonic Filters, the UHF radio system at the FAA Technical Center passed the THD requirement in LDRCL Specification FAA-E-2853, the Electrical Power Policy Implementation at National Airspace System Facilities, FAA Order 6950.2C, and the Electronic Equipment, General requirements Specification FAA-G-2100F. The THD level was 4.2 percent. Without THD filters, the UHF radio configuration in Tonopah, Nevada passed the "Electronic Equipment, General Requirements Specification" FAA-G-2100F only. The THD level was 43.5 percent.

Test Description	Verification Method		Test Location		Notes
	System Level	Integration Level	FAATC	Key Site	
10. Inrush Current Test	T	N/T	*	N/T	2
11. Silent Failure Test	T	T	*	*	3

Verification Method: T=Test, D=Demonstration, A=Analysis, I=Inspection, X=Not Applicable
Notes:

* = Verification Method Conducted

P = Passed, Meets requirement without comment, N/T = Not Tested, N/A = Not Applicable

2 = Meets Specification FAA-G-2100F. "Electronic Equipment, General Requirements Specification".

Does not meet the time requirement of 8 milliseconds for the inrush current to return to 110 percent of its steady state value for equipment connected to the critical bus as required in FAA Order 6950.2C, but as per the DRR checklist, LDRCL will go on the essential bus.

3 = The configuration tested at the key site had 30-minute backup batteries which are not equipped with a Low Voltage Battery Disconnect (LVBD). This configuration passes the silent failure test. However, when the UHF radio is configured with 8-hour backup batteries, the system will have a LVBD. In this configuration, the system fails this test as the current design has a silent failure mode in which the LVBD can fail and drop out causing the backup batteries to disconnect from the system. When this happens, an alarm should be generated but is not.