

**O
T
S
D**

AR-008-928

DSTO-TR-0065

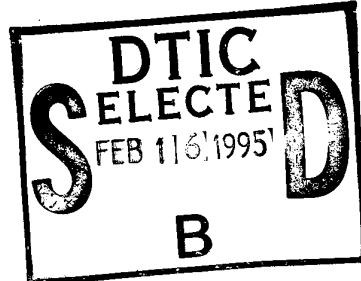

Diffuse Reflectance Spectra of
Energetic Material

Rodney A.J. Borg

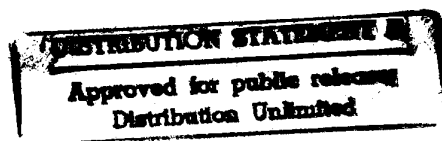

19950214 086

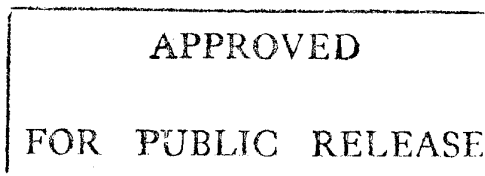
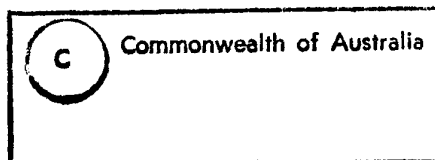

Diffuse Reflectance Spectra of Energetic Material

Rodney A.J. Borg

**Explosives Ordnance Division
Aeronautical and Maritime Research Laboratory**

DSTO-TR-0065

ABSTRACT

The diffuse reflectance spectra of pure, solid HNS, TNT, HMX, RDX and PETN have been recorded. These spectra reveal that all of the high explosives (HE) have strong absorption profiles in the UV region of the spectrum and much weaker absorption in the visible/near infrared. The influence of particle size on the diffuse reflectance spectra has also been investigated. Reducing the particle size leads to a blue shift of the diffuse reflectance spectrum. The strength of the absorption of the pure HE in the UV region obscures details in the absorption profile. Dilution of the HE with a strong reflector was used to reduce the magnitude of the absorption and allow the UV absorption to be revealed in detail. Chemical interaction between the diluent and HE reduces the general applicability of this approach.

DTIC QUALITY INSPECTED

Approved for public release

DEPARTMENT OF DEFENCE

DEFENCE SCIENCE AND TECHNOLOGY ORGANISATION

Published by

*DSTO Aeronautical and Maritime Research Laboratory
GPO Box 4331
Melbourne Victoria 3001*

Telephone: (03) 626 8111

Fax: (03) 626 8999

© Commonwealth of Australia 1994

AR No. 008-928

September 1994

APPROVED FOR PUBLIC RELEASE

Diffuse Reflectance Spectra of Energetic Material

EXECUTIVE SUMMARY

A device based on the direct laser initiation of a secondary high explosive removes the need for sensitive primary explosives. One of the first steps towards achieving this goal is understanding the fundamental process of light absorption by secondary explosives. This report investigates the light absorption characteristics of several high explosives. The influence of particle size on absorption has also been studied. Using diffuse reflectance techniques, we have found that high explosives have stronger absorbances in the UV part of the spectrum and particle size can affect the shape and position of the absorption curves.

Author

Rodney A.J. Borg Explosives Ordnance Division



Rodney Borg graduated from the University of Melbourne in 1987 with a BSc (Hons) in Chemistry. He joined AMRL in 1988 as an Experimental Officer with the Explosives Ordnance Division and in 1989 commenced a PhD at Flinders University. He was awarded a PhD in 1994 for his work on vibrational energy transfer in benzene. Since returning to AMRL in 1992, he has conducted research on the interaction of light with explosives and developing models to predict the performance of explosives.

Contents

1. INTRODUCTION	1
2. EXPERIMENTAL	1
2.1 <i>Materials</i>	1
2.2 <i>Diffuse Reflectance Spectra</i>	2
2.2.1 <i>Apparatus</i>	2
2.2.2 <i>Procedure</i>	2
3. RESULTS AND DISCUSSION	4
3.1 <i>Pure HE Spectra</i>	4
3.1.1 <i>HNS</i>	4
3.1.2 <i>TNT</i>	5
3.1.3 <i>RDX</i>	5
3.1.4 <i>HMX</i>	7
3.1.5 <i>PETN</i>	7
3.1.6 <i>General Features</i>	8
3.2 <i>Particle Size Effects</i>	8
3.3 <i>Dilution studies with MgO</i>	10
3.3.1 <i>HNS</i>	10
3.3.2 <i>HMX</i>	10
3.3.3 <i>RDX, PETN and TNT</i>	10
4. CONCLUSIONS	14
5. ACKNOWLEDGEMENTS	15
6. REFERENCES	15

1. Introduction

Direct laser initiation of energetic materials has attracted considerable research effort world wide for more than 20 years. These studies have demonstrated that secondary high explosives (HE) can be detonated with infrared, visible and UV pulses of electromagnetic radiation. Unfortunately, the relatively high laser power required to effect initiation has precluded the development of a compact fuzing system utilizing laser initiation. Recently it has been shown that the laser initiation of pentaerythritol tetranitrate (PETN) requires less energy and lower power densities when UV radiation is employed [1]. This improved efficiency at shorter wavelengths can be partly attributed to the increasing absorption by PETN as the excitation wavelength is reduced. Knowledge of the UV/visible absorption characteristics of HE provides information that can be used to optimize the laser initiation process. Absorption spectra of solid HE have been obtained using transmission spectroscopy through single crystals [2,3] and HE dispersed in pressed KCl disks [4]. In addition to these transmission experiments, reflectance spectra of solid HE crystals [1, 3, 5, 6] and powders [1] have also been reported.

The diffuse reflectance spectra of pure, solid HNS, RDX, HMX, TNT and PETN are reported in this work. Since HE used in ordnance are typically obtained from powders or fine crystalline material, the HE samples were measured in this form. The influence of particle size on the UV/visible absorption of HE was also investigated. During the course of the experiments it was observed that all of the explosives exhibited very strong absorption at UV wavelengths. This strong absorption may conceal features in the UV absorption of the HE, but by diluting the HE samples with a highly reflective diluent (magnesium oxide) the absorption can be reduced. A series of spectra for the diluted explosives was obtained to examine the UV absorption in detail.

2. Experimental

2.1 Materials

The HE samples 2,2',4,4',6,6'-hexanitrostilbene (HNS) (batch X580, Naval Surface Warfare Center, Whiteoak, MD), RDX BUK Class 5 (mix B5 M038, Royal Ordnance, Bridgewater, UK) and TNT (double sublimed α -TNT, AMRL, DSTO Melbourne) were used as supplied. PETN (ICI Australia) was recrystallised from acetone/water to give a fine powder with an average particle size of 27 μm [7]. Three types of HMX with different particle size distributions were used. The sample designated HMX fine is HMX Grade B (Class 5, Royal Ordnance, Bridgewater, UK) and has a median particle size of 9 μm . The samples designated HMX medium and HMX crystalline were obtained from wet HMX Type A (Lot BGW 364, Royal Ordnance, Bridgewater, UK). The HMX Type A was reduced in particle size using a ball mill, then sieved to yield two fractions

[8]. The finer fraction is designated HMX medium and has a median particle size of 22 μm . The other fraction is labelled HMX crystalline and has a median particle size of 190 μm .

The magnesium oxide (MgO) was ground and then sieved (400 mesh) prior to vacuum heating (3 days at 200 °C). This treatment ensures that all water is removed and any magnesium hydroxide present is converted to magnesium oxide.

2.2 Diffuse Reflectance Spectra

2.2.1 Apparatus

The diffuse reflectance spectra were recorded on a Cary 3 UV/visible spectrophotometer (Varian) fitted with a diffuse reflectance attachment incorporating an integrating sphere (Varian). Sample cells for the HE powders were specially designed and constructed to permit UV/visible measurements. These cells (Figure 1) were made from aluminium, painted matt black to minimize stray light reflections, and fitted with S1-UV commercial quality windows (1" diameter, 1/16" thick).

2.2.2 Procedure

The spectrophotometer is controlled by a PC running the Cary 3 user interface software. Prior to performing a measurement, a baseline scan using two identical reference samples was recorded. The diffuse reflectance attachment was supplied with teflon reference standard disks suitable for this purpose. Alternatively another reference standard could be employed and for some tests MgO was used. One reference sample was placed in the reference port and the other was placed in the sample port of the diffuse reflectance attachment. From the "display" page the option "baseline" was chosen and the baseline was recorded and stored. This baseline will automatically be used in subsequent measurements.

To record the diffuse reflectance spectrum of a HE sample, the sample was packed loosely into a sample cell. Enough powder was added to ensure that a flat, even surface was formed when the quartz window was placed over the sample. After filling, the sample cell was placed in the sample port of the diffuse reflectance attachment and the spectrum recorded.

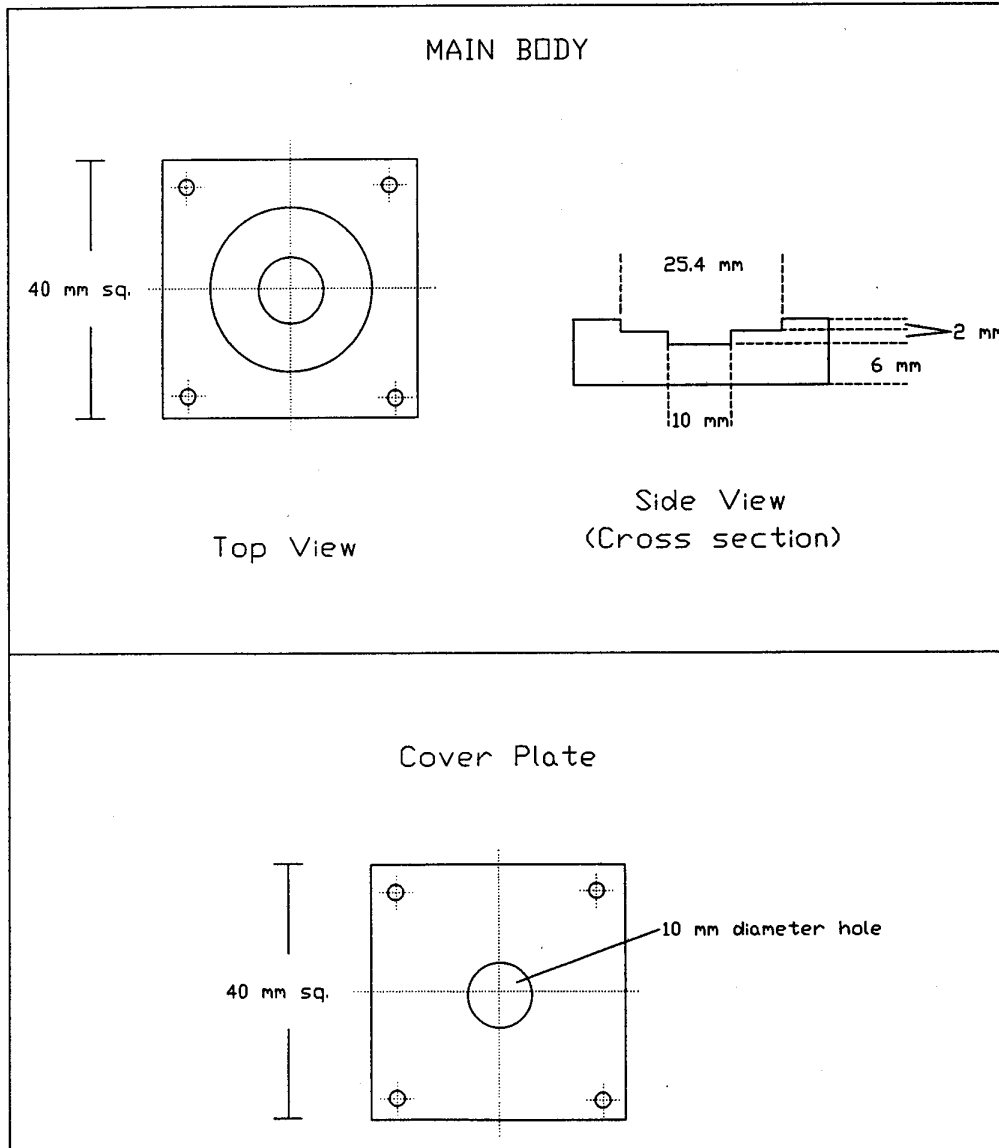

Figure 1: Sample cells.

3. Results and Discussion

3.1 Pure HE spectra

3.1.1 HNS

The diffuse reflectance spectrum of HNS from 200 nm to 800 nm is shown in Figure 2 as % reflectance (relative to teflon) versus wavelength. At 800 nm the % reflectance is approximately 50% implying that half of the incident radiation is absorbed. However, in these experiments the % reflectance is a relative value and in this particular case it is relative to the standard teflon disk. Not only is teflon an excellent reflector of radiation throughout the UV and visible spectrum, but the surface area of the teflon disk presented to the reference port is approximately three times the surface area of the HNS sample presented to the beam. Both of these factors contribute to the low percentage reflectance values in Figure 2. Thus at 800 nm HNS probably absorbs very little, if any, of the incident radiation.

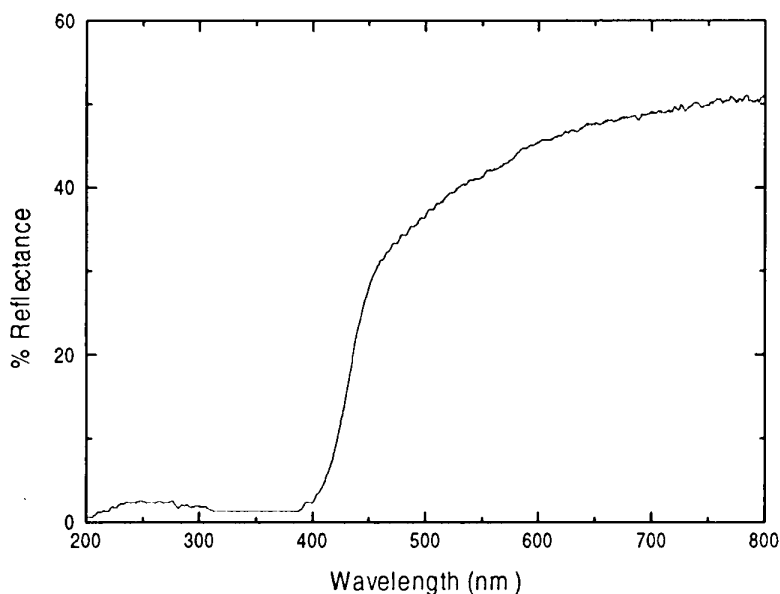

Figure 2: Diffuse reflectance spectrum of solid HNS relative to teflon reference.

The spectrum shows a steadily decreasing reflectance, corresponding to increasing absorption, as the incident wavelength goes from 800 nm down to 460 nm. At 460 nm there is a sharper decrease in reflectance and by 400 nm there is virtually total absorption of the incident light. Between 300 nm and 200 nm there

is a small hump in the reflectance suggesting that there is some band like structure in the absorbance below 400 nm. The exact nature of this structure is obscured by the strength of the absorption in this region but dilution studies presented later will reveal this structure.

The diffuse reflectance spectrum of HNS has been published previously [1] but it is difficult to make close comparisons with this spectrum since the wavelength range extended to 2700 nm. Consequently the region from 200 nm to 800 nm is not particularly clear. Nonetheless the spectra are similar in the 200 to 800 nm range.

The absorption spectrum of HNS dispersed in a KCl disk has been reported [4]. Although it is difficult to determine the peak absorption from our diffuse reflectance spectrum, the peak absorption probably occurs between 300 and 400 nm. This represents a substantial red shift in comparison to the pressed KCl disk spectrum with a maximum at 238 nm. A better estimate of the magnitude of the red shift is facilitated by the dilution studies presented in Section 3.3.

3.1.2 TNT

The diffuse reflectance spectrum of TNT has not been reported previously. Unlike the HNS spectrum, the TNT diffuse reflectance spectrum (Figure 3) is flat from 800 nm down to 600 nm. At 600 nm there is a small dip and then another flat region down to about 450 nm. From 450 nm there is a sharp decrease in reflectance, corresponding to a large increase in absorption, and by 400 nm there is total absorption. As for HNS, there appears to be some structure in the absorption between 200 and 300 nm. It is worthwhile noting that for both HNS and TNT, the sharp increase in absorption occurs between 450 and 400 nm. It seems likely that the trinitrophenyl chromophore is responsible for this feature. Furthermore, the slowly increasing absorption between 800 and 500 nm for HNS is probably due to the stilbene chromophore. Unfortunately a comparison of the TNT diffuse reflectance spectrum and TNT in a pressed KCl disk is not possible since TNT was not one of the explosives studied in the pressed disk work [4].

3.1.3 RDX

The diffuse reflectance spectrum of RDX (Figure 4) is featureless with a strong absorption commencing from 350 nm with total absorption by 300 nm. Like HNS, the diffuse reflectance spectrum of RDX is significantly red shifted in comparison to the absorption spectrum of RDX dispersed in a KCl disk [4].

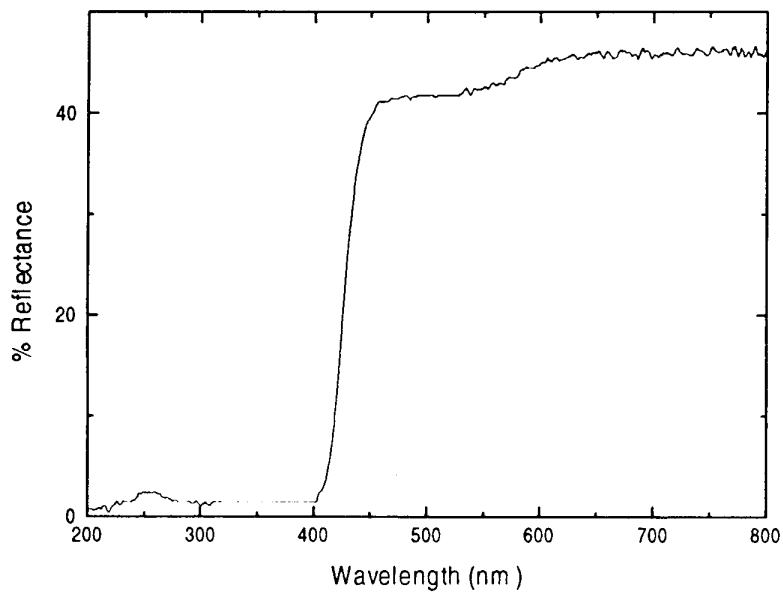

Figure 3: Diffuse reflectance spectrum of solid TNT relative to teflon reference.

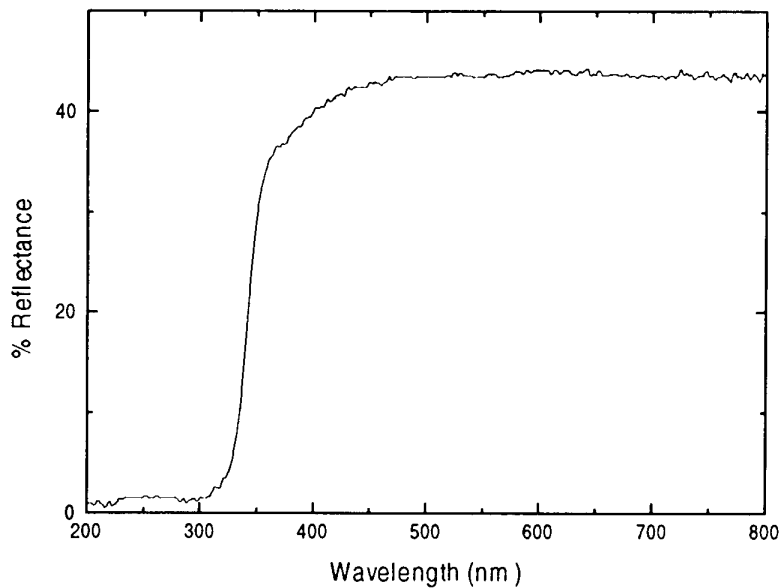

Figure 4: Diffuse reflectance spectrum of solid RDX relative to teflon reference.

3.1.4 HMX

HMX fine was used to record the diffuse reflectance spectrum in Figure 5. The HMX spectrum is almost identical with the RDX spectrum. This is consistent with the fact that RDX and HMX are structurally similar. In particular, the N-NO₂ moieties will be responsible for the majority of the absorption below 350 nm. The diffuse reflectance spectrum of HMX reported by Paisley has a plateau centered near 355 nm that is absent in the spectrum reported in this work. The exact form of the HMX used to record the spectrum reported by Paisley [1], in particular the particle size, was not given. In Section 3.2 we will see that the larger particle size samples of HMX exhibit this plateau whereas the HMX fine sample lacks this feature. Once again the diffuse reflectance spectrum of HMX is red shifted in comparison to the spectrum of HMX dispersed in a KCl disk [4].

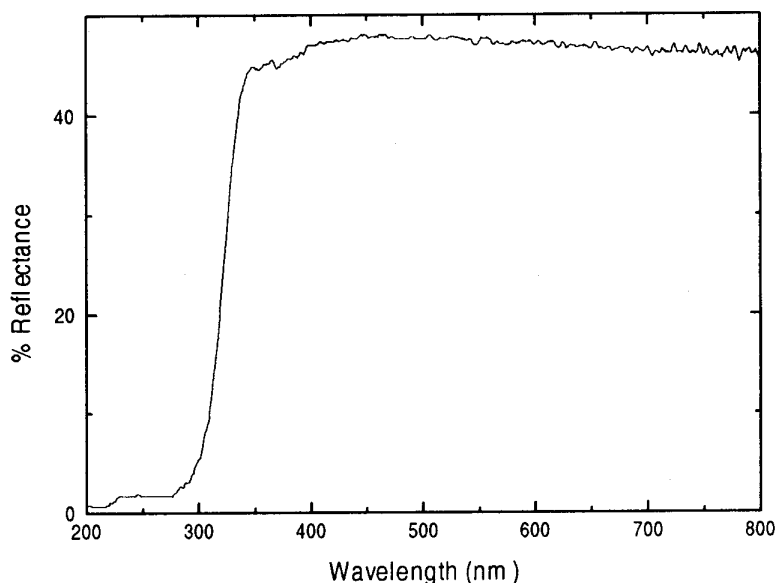

Figure 5: Diffuse reflectance spectrum of solid HMX fine relative to teflon reference.

3.1.5 PETN

The PETN diffuse reflectance spectrum (Figure 6) is similar to both the RDX and HMX spectra. However it is slightly blue shifted relative to the spectra of the nitramines. As with HNS, RDX and HMX, the PETN diffuse reflectance spectrum is red shifted relative to the absorption spectrum of PETN in pressed KCl disks. The previously reported diffuse reflectance spectrum of PETN [1] shows non-linear reflectance in the 800 nm to 400 nm range, unlike the spectrum in Figure 6. It also appears that the absorption edge is blue shifted relative to the spectrum in Figure 6. In Section 3.2 it will be shown that particle size can

influence the shape and position of the diffuse reflectance spectrum. It seems likely that the differences observed between the two diffuse reflectance spectra can be attributed to differences in the particle size distributions of the samples.

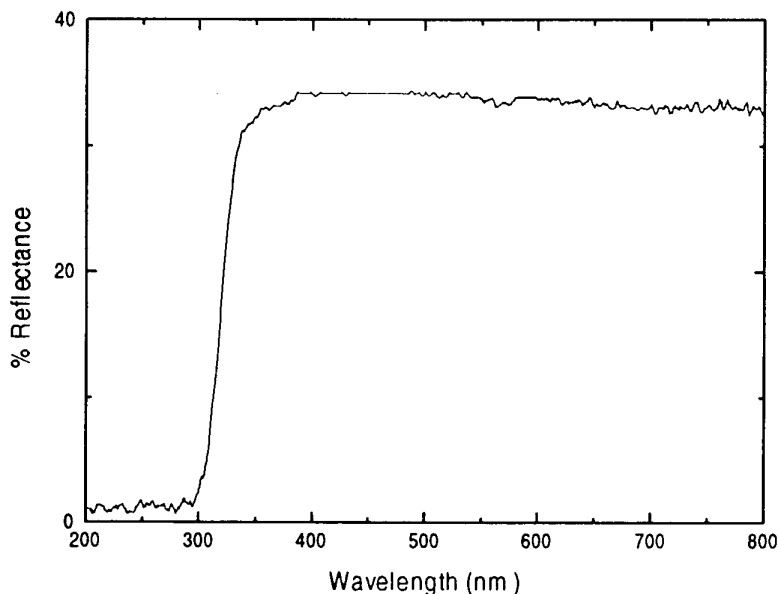

Figure 6: Diffuse reflectance spectrum of solid PETN relative to teflon reference.

3.1.6 General Features

The diffuse reflectance spectra of the pure solid HEs show that all of these HEs have strong absorbances in the UV part of the spectrum. There do not appear to be characteristic frequencies in the UV where any of these explosives has an exceptionally strong resonance. However, since the absorption across the UV is strong, such resonances may be masked. For this reason the dilution studies described in Section 3.3 were undertaken.

3.2 Particle Size Effects

A limited study of the influence of particle size was undertaken since the particle size of the sample can influence the shape of the diffuse reflectance spectrum [9, 10, 11, 12]. HMX was available as a fine powder, a medium powder and as a coarse crystalline solid. The diffuse reflectance spectrum of each of these samples, relative to teflon, is shown in Figure 7. The spectrum of the crystalline material exhibits a substantially lower reflectance for the 450 nm to 800 nm range in comparison to the finer samples. It is likely that the increased scattering caused by the larger particles of the crystalline sample results in the reduced reflection in this range.

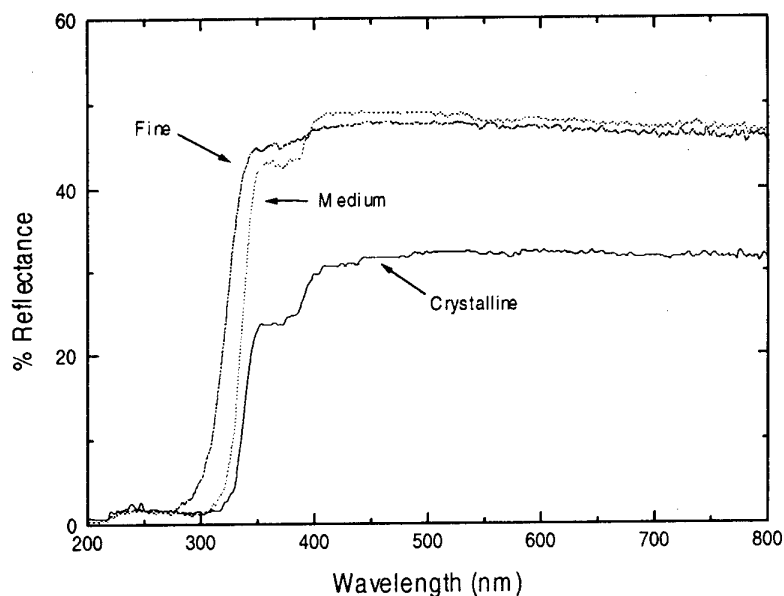

Figure 7: Diffuse reflectance spectrum of solid HMX (fine, medium and crystalline) relative to teflon reference.

The spectra for the medium and crystalline HMX have a different shape in the 300 nm to 400 nm range in comparison to the fine HMX spectrum. The larger particle size samples have a plateau in this range that is absent in the fine HMX spectrum. At this stage we do not have a definitive explanation for this difference. As pointed out in Section 3.1.4, the previously reported diffuse reflectance spectrum of HMX [1] also exhibits the plateau feature. This suggests that the HMX sample employed by Paisley has a particle size distribution similar to the HMX medium or HMX crystalline used in this work. Unfortunately, as mentioned in Section 3.1.4, the particle size of the samples used by Paisley is not provided.

The other influence of particle size concerns the position of the major absorption edge in the spectra. As the particle size of the sample decreases, the corresponding spectra become progressively blue shifted. This effect is not peculiar to HMX. Diffuse reflectance spectra of powdered and crystalline nitrated stilbenes also show that the spectrum of the powder is blue shifted in comparison to the spectrum of the larger particle size crystals [13].

3.3 Dilution studies with MgO

All of the HE samples studied in this work exhibit strong absorption in the UV part of the spectrum. The strength of this absorption obscures any features in the spectra that may be present. The analogy of this situation in solution absorption spectrophotometry occurs when a solution is too concentrated and the remedy in this case is to dilute the solution. When measuring diffuse reflectance spectra of solids the sample can be diluted by using a strongly reflecting, inert diluent. In this work MgO was chosen because it has adequate reflectance throughout the spectral range of interest (ie 200 nm to 800 nm). For the spectra reported in this section each HE was mixed with MgO and the diffuse reflectance of the mixed sample was measured relative to a pure MgO sample held in one of the sample cells.

3.3.1 HNS

The diffuse reflectance spectrum of the mixed sample of HNS and MgO is shown in Figure 8. The sample was diluted to give 33% w/w HNS in MgO. The amount of absorption has been reduced sufficiently to observe the shape of the spectrum in the UV region. The absorption maximum occurs at 382 nm whereas the absorption maximum of HNS dispersed in a KCl disk occurs at 238 nm [4]. This large red shift (144 nm) for the diffuse reflectance spectrum suggests that the KCl disk method may not be the best method for determining the UV absorption characteristics of solid explosives. In fact, the KCl pressed disk spectra bear much more resemblance to the solution spectra than they do to the diffuse reflectance spectra.

3.3.2 HMX

A 19% w/w HMX mixture was used to obtain the diffuse reflectance spectrum of diluted HMX shown in Figure 9. The absorption maximum occurs at 279 nm which represents a red shift of 46 nm relative to the long wavelength maximum at 233 nm observed in a KCl disk [4]. For HMX the KCl disk spectrum is more similar to the solution spectrum than to the diffuse reflectance spectrum.

3.3.3 RDX, PETN and TNT

The diffuse reflectance spectra of MgO mixtures of RDX, PETN and TNT all show spectral features that were absent in the spectrum of the pure HE. The diffuse reflectance spectrum of a 64% w/w RDX mixture (Figure 10) has a weak band centered at 500 nm that does not appear in the pure RDX spectrum. There is another weak band above 550 nm in the mixed sample spectrum that is absent in the pure RDX spectrum. The major absorption feature below 350 nm is similar to the pure RDX spectrum.

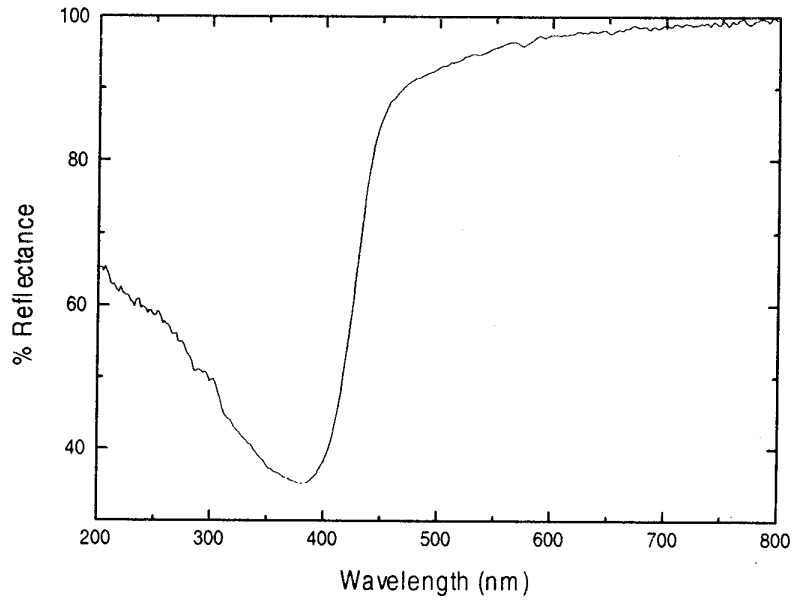

Figure 8: Diffuse reflectance spectrum of HNS diluted with MgO.

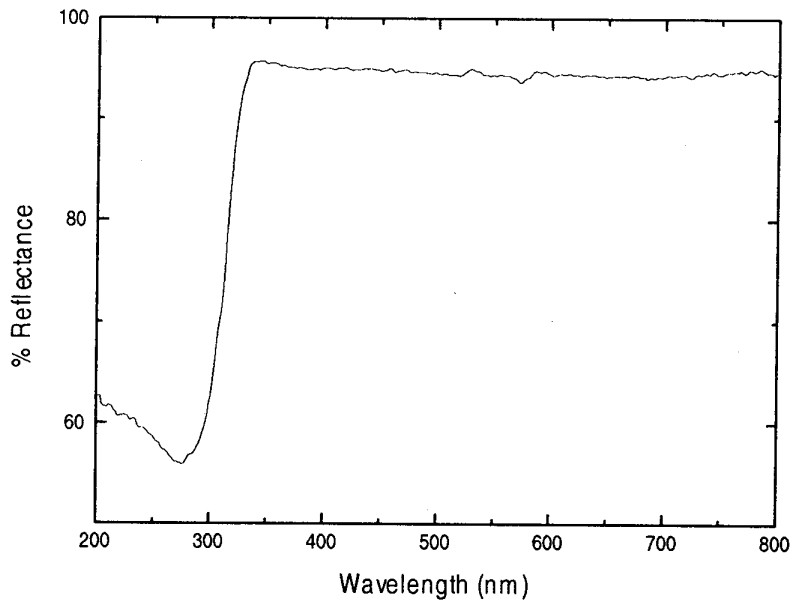

Figure 9: Diffuse reflectance spectrum of HMX diluted with MgO.

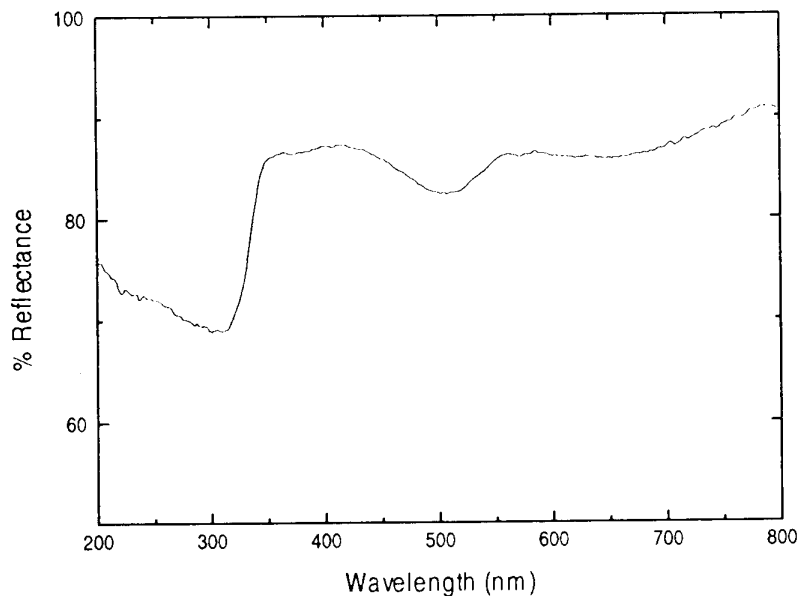

Figure 10: Diffuse reflectance spectrum of RDX diluted with MgO.

The PETN/MgO (39% w/w PETN) diffuse reflectance spectrum (Figure 11) displays a small reduction in absorption near 325 nm. This appears as a small peak in the diffuse reflectance spectrum. This feature does not appear in the diffuse reflectance spectrum of pure PETN.

When TNT was mixed with MgO there was an immediate and readily discernible color change. Pure TNT is a very pale yellow/brown color and MgO is a pure white solid. The mixture of these two solids results in a pale purple color. Obviously the spectral characteristics of this mixture will be significantly different to that of pure TNT. The diffuse reflectance spectrum shown in Figure 12 was obtained with a 44% w/w TNT mixture. This spectrum displays three distinct bands with absorption maxima at 234 nm, 367 nm and 527 nm. This spectrum bears little resemblance to the diffuse reflectance spectrum of pure TNT shown in Figure 3.

For these three HE samples, mixing with MgO has altered their fundamental UV/visible absorption characteristics. This is evident from the appearance of new features in the diffuse reflectance spectra of the mixed samples in comparison to the spectra of the pure HE solids. There are a number of interactions that can occur that will lead to these observed spectral changes. MgO can act as a base and the methyl protons of TNT are relatively acidic. It is therefore likely that the mixing of MgO and TNT results in an acid/base interaction that gives rise to new species. This acid/base interaction between MgO and TNT is supported by solution absorption spectra of TNT. The UV/visible absorption spectrum of TNT in solution with KOH [14] has three absorption bands with maxima at 265 nm, 377 nm and 516 nm. This correlates well with the diffuse reflectance spectrum of the TNT/MgO mixture. Apart from acid/base interactions, other processes can also be responsible for the observation of new features in the spectra of the HE/MgO mixtures. These include charge transfer complex formation and polarization effects [9].

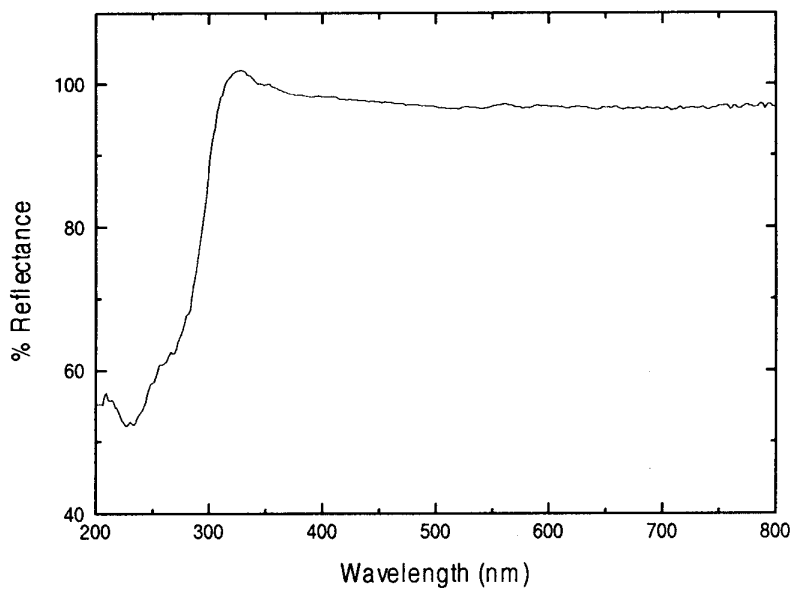

Figure 11: Diffuse reflectance spectrum of PETN diluted with MgO.

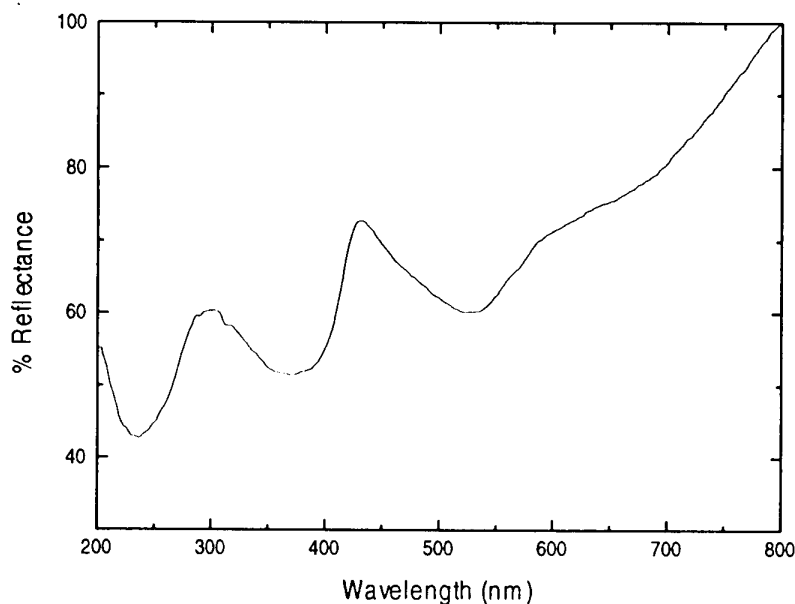

Figure 12: Diffuse reflectance spectrum of TNT diluted with MgO.

4. Conclusions

Diffuse reflectance spectroscopy is a convenient and accurate method for determining the UV/visible absorption characteristics of solid powders. For HNS, HMX, RDX, TNT and PETN, the diffuse reflectance spectra show strong, broad absorption in the UV region of the spectrum. There are no characteristic resonances for any of these explosives in the UV/visible region that may be exploited in a laser initiation application. However, laser initiation may be more efficient at UV wavelengths (as is the case with PETN) due to the strong absorption and the possibility of direct decomposition from electronic excited states. It is important to provide an indication of the particle size when reporting diffuse reflectance spectra since the absorption edge is blue shifted with decreasing particle size.

Dilution of HE samples with MgO can reveal in detail the absorption profile of HNS and HMX in the UV part of the spectrum where the strength of the absorption by the pure HE obscures these details. However, MgO interacts with RDX, PETN and TNT thus changing their fundamental absorption characteristics. For these HEs, dilution with MgO cannot be used to study the UV absorption in greater detail.

5. Acknowledgements

I am grateful to Dr Ken Smit for a number of useful discussions regarding this work.

6. References

- 1 Paisley, D.L. (1989). Prompt Detonation of Secondary Explosives by Laser, 9th Symp. (Int.) on Detonation, Portland, OR. p492
- 2 Bowden, F.P. and Yoffe, A.D. (1958). Fast Reactions in Solids, Academic Press, New York, p 107.
- 3 Marinkas, P.L., Mapes, J.E., Downes, D.S., Kemmey, P.J. and Forsyth, A.C. (1976). Molecular Crystals Liquid Crystals, 35, 15.
- 4 Smit, K.J. (1991). Journal of Energetic Materials, 9, 81.
- 5 Stals, J. (1970). Transactions of the Faraday Society, 67, 1739.
- 6 Marinkas, P.L. (1977). Journal of Luminescence, 15, 57.
- 7 Redman, L. Private communication.
- 8 Dagley, I.J., Montelli, L. and Parker, R.P. (1993). Pressed Booster Compositions with Moderate Cookoff Responses. (MRL Technical Report MRL-TR-93-41). Marybyrnong, Vic: Materials Research Laboratory.
- 9 Frei, R.W. and MacNeil, J.D. (1973). Diffuse Reflectance Spectroscopy in Environmental Problem-Solving, CRC Press, Cleveland, Ohio.
- 10 Zeitlen, H. and Niimoto, A. (1959). Analytical Chemistry, 31, 1167.
- 11 Kortum, G. and Schreyer, G. (1955). Angew. Chem. Int. Ed. Engl., 67, 694.
- 12 Frei, R.W. and Zeitlen, H. (1965). Analytica Chimica Acta, 23, 32.
- 13 Borg, R.A.J. Unpublished results.
- 14 Smit, K. Private communication.

REPORT NO.
DSTO-TR-0065AR NO.
AR-008-928REPORT SECURITY CLASSIFICATION
Unclassified

TITLE

Diffuse reflectance spectra of energetic material

AUTHOR(S)
Rodney A.J. BorgCORPORATE AUTHOR
DSTO Aeronautical and Maritime Research Laboratory
GPO Box 4331
Melbourne Victoria 3001REPORT DATE
September 1994TASK NO.
DSTO 92/296SPONSOR
DSTOFILE NO.
510/207/0175REFERENCES
14PAGES
23

CLASSIFICATION/LIMITATION REVIEW DATE

CLASSIFICATION/RELEASE AUTHORITY
Chief, Explosives Ordnance Division

SECONDARY DISTRIBUTION

Approved for public release

ANNOUNCEMENT

Announcement of this report is unlimited

KEYWORDS

Energetic materials
Hexanitrostilbene
TNTHMX
RDX
ExplosivesAbsorption
Particle size
Electromagnetic radiation

ABSTRACT

The diffuse reflectance spectra of pure, solid HNS, TNT, HMX, RDX and PETN have been recorded. These spectra reveal that all of the high explosives (HE) have strong absorption profiles in the UV region of the spectrum and much weaker absorption in the visible/near infrared. The influence of particle size on the diffuse reflectance spectra has also been investigated. Reducing the particle size leads to a blue shift of the diffuse reflectance spectrum. The strength of the absorption of the pure HE in the UV region obscures details in the absorption profile. Dilution of the HE with a strong reflector was used to reduce the magnitude of the absorption and allow the UV absorption to be revealed in detail. Chemical interaction between the diluent and HE reduces the general applicability of this approach.

Diffuse Reflectance Spectra of Energetic Material

Rodney A.J. Borg

(DSTO-TR-0065)

DISTRIBUTION LIST

Director, AMRL
Chief, Explosives Ordnance Division
Dr B.W. Thorpe
Dr Rodney A.J. Borg
Library, AMRL Maribyrnong
Library, AMRL Fishermens Bend

Chief Defence Scientist (for CDS, FASSP, ASSCM) 1 copy only
Director, ESRL
Head, Information Centre, Defence Intelligence Organisation
OIC Technical Reports Centre, Defence Central Library
Officer in Charge, Document Exchange Centre 7 copies
Senior Defence Scientific Adviser
Air Force Scientific Adviser, Russell Offices
Scientific Adviser - Policy and Command
Senior Librarian, Main Library DSTOS
Librarian, DSD, Kingston ACT
Serials Section (M List), Deakin University Library, Deakin University, Geelong 3217
NAPOC QWG Engineer NBCD c/- DENGRS-A, HQ Engineer Centre, Liverpool
Military Area, NSW 2174
ABCA, Russell Offices, Canberra ACT 2600 4 copies
Librarian, Australian Defence Force Academy
Head of Staff, British Defence Research and Supply Staff (Australia)
NASA Senior Scientific Representative in Australia
INSPEC: Acquisitions Section Institution of Electrical Engineers
Head Librarian, Australian Nuclear Science and Technology Organisation
Senior Librarian, Hargrave Library, Monash University
Library - Exchange Desk, National Institute of Standards and Technology, US
Acquisition Unit (DSC-EO/GO), British Library, Boston Spa, Wetherby, Yorkshire LS23 7BQ, England
Library, Chemical Abstracts Reference Service
Engineering Societies Library, US
Documents Librarian, The Center for Research Libraries, US
Army Scientific Adviser, Russell Offices - data sheet only
Navy Scientific Adviser - data sheet only
Director General Force Development (Land) - data sheet only
DASD, APW2-1-OA2, Anzac Park West, Canberra ACT - data sheet only
SO (Science), HQ 1 Division, Milpo, Enoggera, Qld 4057 - data sheet only
Librarian - AMRL Sydney - data sheet only
Counsellor, Defence Science, Embassy of Australia - data sheet only
Counsellor, Defence Science, Australian High Commission - data sheet only
Scientific Adviser to DSTC Malaysia, c/- Defence Adviser - data sheet only
Scientific Adviser to MRDC Thailand, c/- Defence Attache - data sheet only

Dr Dennis Paisley, Detonation Systems DX-10 Mailstop P950, LANL, Los Alamos, New Mexico 87545
Mr D.J. Hatt, EOD
Dr K.J. Smit, EOD