

DIA

DDB-2680-62-79

S DTIC ELECTE D
G FEB 14 1995

**HANDBOOK
ON THE
CUBAN
ARMED FORCES**



APRIL 1979

DISTRIBUTION STATEMENT A

Approved for public release;
Distribution Unlimited

SUMMARY

Cuba's Ministry of the Revolutionary Armed Forces (MINFAR) is composed of the regular components—the Army, the Navy and the Air and Air Defense Force—plus the paramilitary Youth Labor Army, and Civil Defense. The Ministry of Interior (MININT) has two military units—the Special Troops and the Border Guard Troops—as well as the paramilitary Department of State Security. Fidel Castro and his brother, Raul, who hold the top two positions in the military, the government, and the Cuban Communist Party, clearly control the country. The two have built an unusually united, disciplined, ideologically indoctrinated, and combat-experienced military force which is one of the strongest in Latin America.

At the national level, General Raul Castro, who heads MINFAR, controls all military and paramilitary forces. MINFAR's First Deputy Minister and Chief of the General Staff reports to him and exercises supervision over the General Staff, several national commands such as the Central Political Directorate, the Rear Services Headquarters (Logistics), and the Navy. The First Deputy Minister and Chief of the General Staff exercises direct command over the Army, which is the largest component. The military forces are organized regionally, with the overseas commands reporting directly to MINFAR.

Each Cuban male has a compulsory three-year military service obligation, which can be fulfilled by serving in either MINFAR or MININT. Trained specialists and fighting men are subject to regular recall and can be mobilized individually or en masse through tested mobilization procedures. The reserves are well integrated into the military, and thousands have received combat experience in Africa.

The Cuban military has made major improvements since the mid-1970s. Its organization, strategy and tactics are modeled on those of the Soviet military; however, there are significant differences based on Cuba's less sophisticated equipment and lower manning levels. The repetitive training and strict compartmentalization produces a well-trained but specialized soldier, who follows orders unquestioningly. Cuban tactics are designed to exploit the capabilities of the infantry, although the military is improving its armored capabilities. The military is equipped primarily with conventional Soviet arms, most of which are secondline. However, the Cubans have recently acquired some firstline Soviet equipment, such as a few ZSU-23-4 self-propelled 23-mm Antiaircraft guns and the BM-21 (40-round) Rocket Launchers.

Proud of its past accomplishments, especially its military campaigns in Africa, the Cuban Armed Forces is determined to continue its development.

FOREIGN ABBREVIATIONS

<u>Foreign Abbreviation</u>	<u>Foreign Expansion</u>	<u>English Translation</u>
BME	Base Material de Estudios	Basic Study Materials
CDR	Comites de Defensa de la Revolucion	Committees for the Defense of the Revolution
CPEN	Centro de Preparacion de Especialistas Navales	Center for Naval Specialist Training
CJC	Columna Juvenil del Centenario	Centennial Youth Column
DAAFAR	Defensa Antiaerea y Fuerza Aerea Revolucionaria	Antiair Defense and Revolutionary Air Force (Air and Air Defense Force)
DIP	Divisiones de Infanteria Permanentes	Permanent Infantry Divisions
DSE	Departamento de Seguridad del Estado	Department of State Security
EJT	Ejercito Juvenil del Trabajo	Youth Labor Army
EVMCC	Escuelas Vocacionales Militares Camilo Cienfuegos	Camilo Cienfuegos Military Vocational Schools
FAR	Fuerzas Armadas Revolucionarias	Revolutionary Armed Forces
ITM	Instituto Tecnico Militar	Military Technical Institute
MGR	Marina de Guerra Revolucionaria	Revolutionary Navy
MINFAR	Ministerio de las Fuerzas Armadas Revolucionarias	Ministry of the Revolutionary Armed Forces
MININT	Ministerio del Interior	Ministry of Interior
MPLA	Movimento Popular de Liberacao de Angola	Popular Movement for the Liberation of Angola

MNR	Milicias Nacionales Revolucionarias	National Revolutionary Militia
PCC	Partido Comunista de Cuba	Cuban Communist Party
PNR	Policia Nacional Revolucionaria	National Revolutionary Police
SMG	Servicio Militar General	General Military Service
SNTC-FAR	Sindicato Nacional de Trabajadores Civiles de las Fuerzas Armadas Revolucionarias	National Union of Revolutionary Armed Forces Civilian Workers
TGF	Tropas de Guardafronteras	Border Guard Troops
UJC	Union de Jovenes Comunistas	Union of Young Communists

CHAPTER 1 THE CUBAN ARMED FORCES

Section A—General

1. HISTORICAL DEVELOPMENT

a. *Fidel Castro's Seizure of Power*

Cuba, an island with a population of approximately 9,700,000, is one of the most militarized countries in Latin America. The history of the present Cuban military dates from 26 July 1953, when a group led by Fidel Castro attacked the Moncada Army Barracks in the eastern city of Santiago de Cuba. This act led to the imprisonment of Fidel and Raul Castro. Following their release in 1955, the Castro brothers went to Mexico, reorganized their group and continued plotting to overthrow the government of President Fulgencio Batista. The Castros named their group the "26th of July Movement" in commemoration of the attack on Moncada. In late November 1956, the group sailed from Mexico in the yacht *Granma* intent on creating a revolt in Cuba. Batista's forces intercepted the rebels, decimating the 82-man force within 3 days after it landed on 2 December 1956. The few survivors fled into the nearby Sierra Maestra (a chain of mountains) where the Castros began to rebuild their rebel army. Offensive actions began with hit-and-run tactics and the rebel army gradually grew into a more conventional force which ultimately compelled the Cuban dictator, Fulgencio Batista, to flee the country on 1 January 1959.

b. *Castro's Consolidation of Power*

When Fidel Castro and his guerrilla comrades assumed power, they abolished Batista's military establishment, transferring its duties to the 3,000-man Rebel Army which was soon renamed the Revolutionary Armed Forces (FAR). Some of those who had served in Batista's forces were incorporated into the FAR, but most were released. In October 1959, Fidel Castro created the Ministry of the Revolutionary Armed Forces (MINFAR) with Raul Castro as its head. Because of the shortage of trustworthy, competent and disciplined pro-Castro civilians, many of the "guerrilla elite" became Cuba's leaders and continue to dominate the government today.

Fidel Castro, in establishing a Socialist state, developed two organizations to mobilize popular support. The first was the National Revolutionary Militia (MNR), created in October 1959 and composed primarily of peasants and workers. Citizens were pressured to join the MNR as a patriotic duty. The second organization, founded in September 1960, was the Committees for the Defense of the Revolution (CDR), composed of people in every neighborhood. Originally, the CDR served as local vigilance committees, supporting the security apparatus. Now, it also plays an important propaganda role and is a significant link between Fidel and the people.

In June 1961, Castro established the organization now known as the Ministry of Interior (MININT). Since its founding, MININT has very efficiently implemented its primary mission, that of assuring internal order.

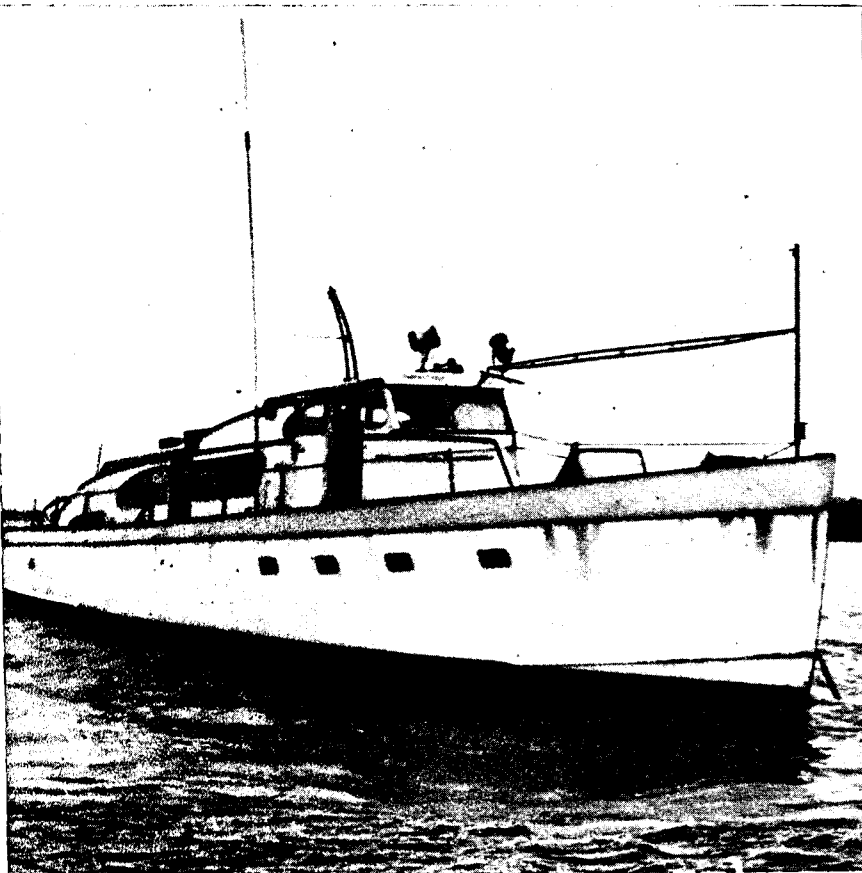

This is the yacht *Granma* that Fidel Castro's 82-man group used to land in Cuba on 2 December 1956. It is now a national monument.

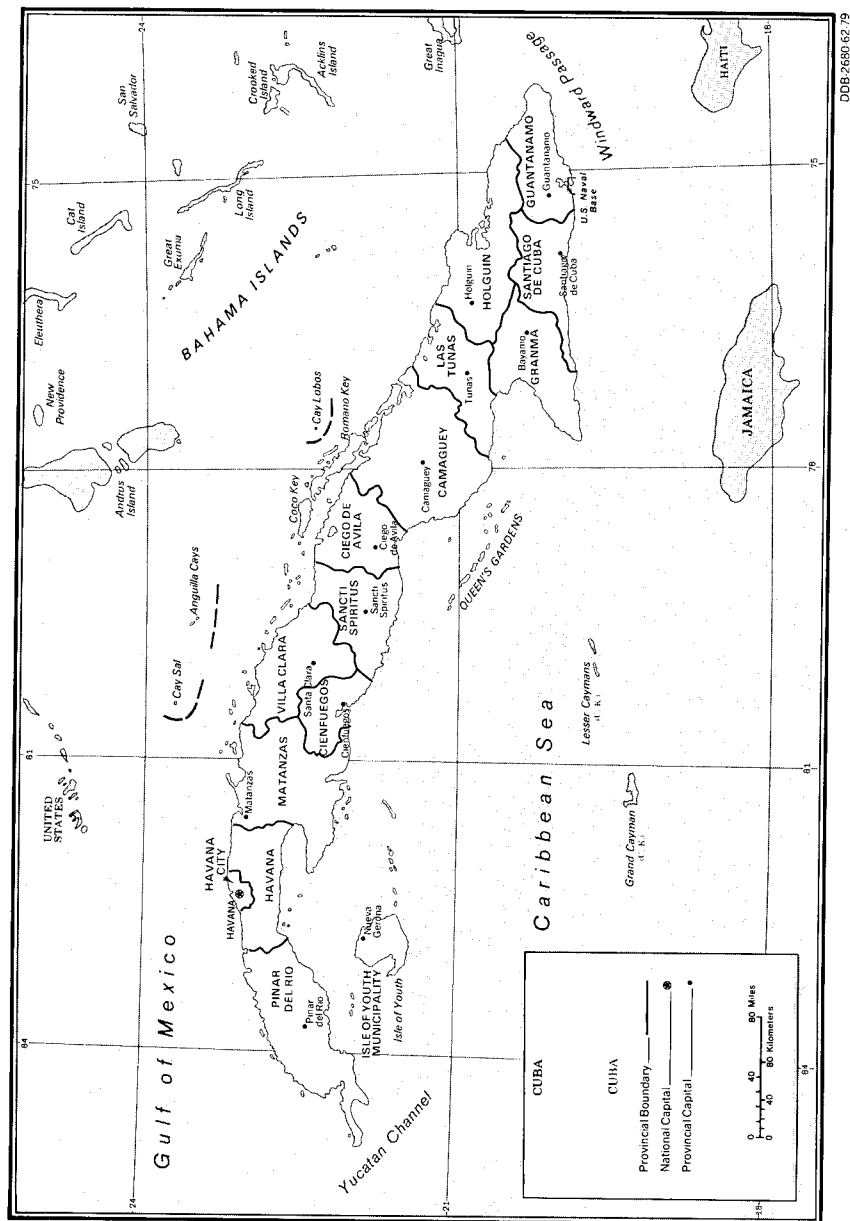

DOB-2680-62-79

Figure 1. Map of Cuba

Following Castro's assumption of power, relations between the United States and Cuba quickly became strained because of Castro's Socialist programs and anti-US actions. In May 1960, Cuba established diplomatic relations with the Soviet Union, and in January 1961, the US broke diplomatic relations with Cuba. Cuba's first real military test occurred in April 1961 when it successfully defeated the 1,200-man exile force which landed at the Bay of Pigs. The following year, US reconnaissance aircraft discovered Soviet intermediate- and medium-range ballistic missiles in Cuba. The October 1962 Missile Crisis occurred when the United States demanded that the Soviet Union withdraw all strategic offensive weapons. The Soviets acceded even though Castro opposed the removal.

As he consolidated his government, Castro improved and expanded his military forces. The first step was the establishment of the Air and Air Defense Force (DAAFAR) during the spring of 1961. Beginning in early 1963, several military schools were founded for infantry, tank, artillery and communications training. In August 1963, Castro formally established the Revolutionary Navy (MGR). That November, the first compulsory military service law was passed, and in December Castro began to establish Cuban Communist Party (PCC) cells within the military to rally support for the regime's policies and to insure unity of control.

The Cuban Government also reorganized and expanded its regular Army at the expense of the National Revolutionary Militia (MNR). The more professional and loyal militia members were transferred to the regular Army; the others were reorganized into the Popular Defense Forces, a new military reserve organization. In 1965, Cuban forces defeated the last remnants of counterrevolutionary forces fighting in the mountains. In June 1966, the Popular Defense Forces were absorbed into the newly established MINFAR Civil Defense units.

c. Reorganization and Modernization of the Military

Since 1970, MINFAR has been restructured and military training has been upgraded in order to strengthen combat readiness. In addition, supply and maintenance methods and facilities have been greatly improved. These changes have been accomplished with considerable Soviet military assistance. MINFAR is still headed by Raul Castro. An excellent administrator, he has improved the overall quality of the military while reducing the active duty strength by transferring thousands to the expanded ready reserve forces, and has thoroughly integrated the ready reservists with the active military forces. In April 1972, the Navy and DAAFAR were separated from the Army and their respective chiefs were elevated to the positions of deputy ministers.

As part of the professionalization effort, the Youth Labor Army (EJT) was established in August 1973 as a paramilitary labor force. The formation of the EJT allowed the regular military, which had devoted a significant part of its manpower to civic action projects since the advent of compulsory service in 1963, to devote full time to military matters. Also in August 1973, the Cuban Government expanded its compulsory service laws to require all male citizens to serve for 3 years in either MINFAR (including the EJT) or in MININT. Those who obtain deferrals for technical or advanced training are obligated to "social service" for up to 3 years in one of several government agencies.

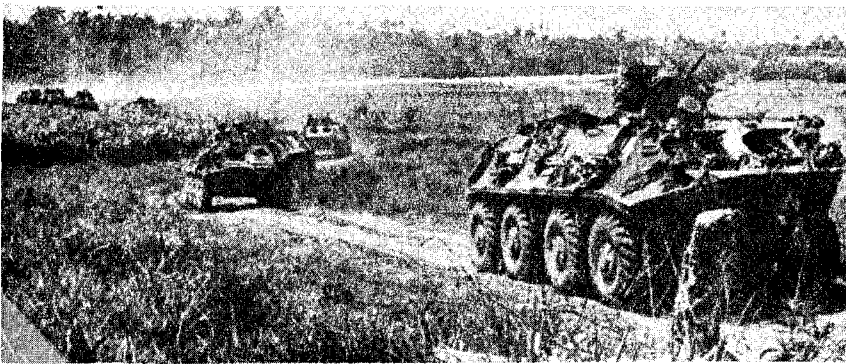

Cuban forces have been increasing their mobility. Here a column of mechanized infantry units advance in BTR-60PB Armored Personnel Carriers.

The Cuban Armed Forces are a powerful, well-trained and united military force. Encouraged by what they perceive as successful encounters with the United States and, more recently, by their successful support of both the Popular Movement for the Liberation of Angola (MPLA) and Ethiopian forces, the Cuban Government and military exude pride and confidence. Looking to the past as a source of inspiration, MINFAR is continuing its modernization and development.

2. MISSIONS AND CAPABILITIES

a. *Missions*

The missions of the Cuban Armed Forces are to provide territorial defense, to maintain internal security and to provide military aid and/or combat assistance to selected foreign countries or groups.

b. *Capabilities*

The Cuban Armed Forces are capable of providing a tenacious defense of the island. They also have a small quick-strike capability off the island; the capability is limited because of insufficient sea and air transport. The Cuban Armed Forces can move rapidly into the nearby Caribbean area, including the countries bordering the Gulf of Mexico, and northern South America as well as the southern United States with small, lightly armed and highly trained units. Cuba depends on Soviet air transport support for large-scale, long-distance troop deployments. However, the experiences in Africa have shown that by using its merchant fleet, Cuba can undertake and sustain a long-term deployment and supply effort.

MINFAR ready-reserve personnel, particularly those assigned to Army units, can be mobilized within 4 hours. MINFAR and MININT personnel are well schooled in individual combat skills, and thousands of troops have now had actual combat experience in Angola and Ethiopia. However, since personnel are rarely cross-trained, units are dependent upon key personnel, particularly in the command structure. Should any key individual be incapacitated, the remaining members of the unit do not have the training necessary to fill the vacated position and to function effectively.

The Cuban Armed Forces are capable of maintaining and repairing most of their equipment. They are, however, dependent on outside sources, primarily the Soviet Union, for almost all military equipment, petroleum, oil and lubricants, and spare parts. Cuba does manufacture some ammunition.

3. NATIONAL ORGANIZATION OF THE ARMED FORCES

a. *General*

In addition to its own forces, the Ministry of the Revolutionary Armed Forces has jurisdiction over the organization, weapons and combat training and, in emergency situations, over deployment of military units in MININT. Both MINFAR's Civil Defense and MININT have military and nonmilitary units. Fidel Castro is Commander in Chief of all armed forces (figure 2).

b. *Staff Organization of the Ministry of the Revolutionary Armed Forces (MINFAR)*

MINFAR is located in Havana. Its national bureaucratic structure (figure 3) is headed by Minister of the Revolutionary Armed Forces General Raul Castro (figure 2) and has three principal groupings: the Office of the Ministry and the units that report directly to it; the General Staff and its components (figure 4); and seven national commands whose chiefs are usually Deputy Ministers. The major troop command organizations—the Isle of Youth Military Region, the Western, Central and Eastern Armies, and the troops deployed overseas—are directly subordinate to the First Deputy Minister, Chief of the General Staff, who is Major General Senen Casas (figure 2).

c. *Staff Organization of the Ministry of the Interior (MININT)*

MININT, a military/paramilitary organization, is responsible for internal security and all related functions. Information on the complete role that MININT plays in the Cuban Armed Forces and MININT's exact relationship with MINFAR is not available. However, MININT does have military units which are employed in Cuba and have been deployed abroad. Two of MININT's military units are the Special Troops, an elite Ranger-type fighting force, and the Border Guard Troops, which are responsible for coastal defense. Most MININT personnel wear uniforms and have military ranks.

MININT is headed by the Minister of the Interior. The present incumbent is Major General Sergio del Valle (figure 2), who is a member of the Cuban



Fidel CASTRO Ruz
First Secretary of the Cuban Communist
Party's Central Committee
General of the Army, Commander in Chief.



Raul CASTRO Ruz
Second Secretary of the Cuban Communist
Party's Central Committee
General, Minister of the Revolutionary
Armed Forces.

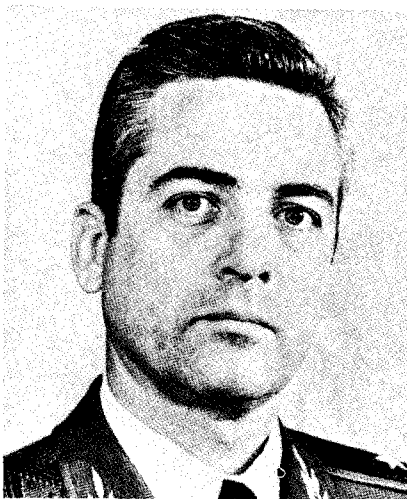

Senen CASAS Regueiro
Member of the Cuban Communist Party's
Central Committee
Major General, First Deputy Minister, Chief
of the General Staff.



Sergio del VALLE Jimenez
Member of the Cuban Communist Party's
Politburo
Major General, Minister of the Interior.

Figure 2. Key Cuban Military Leaders.

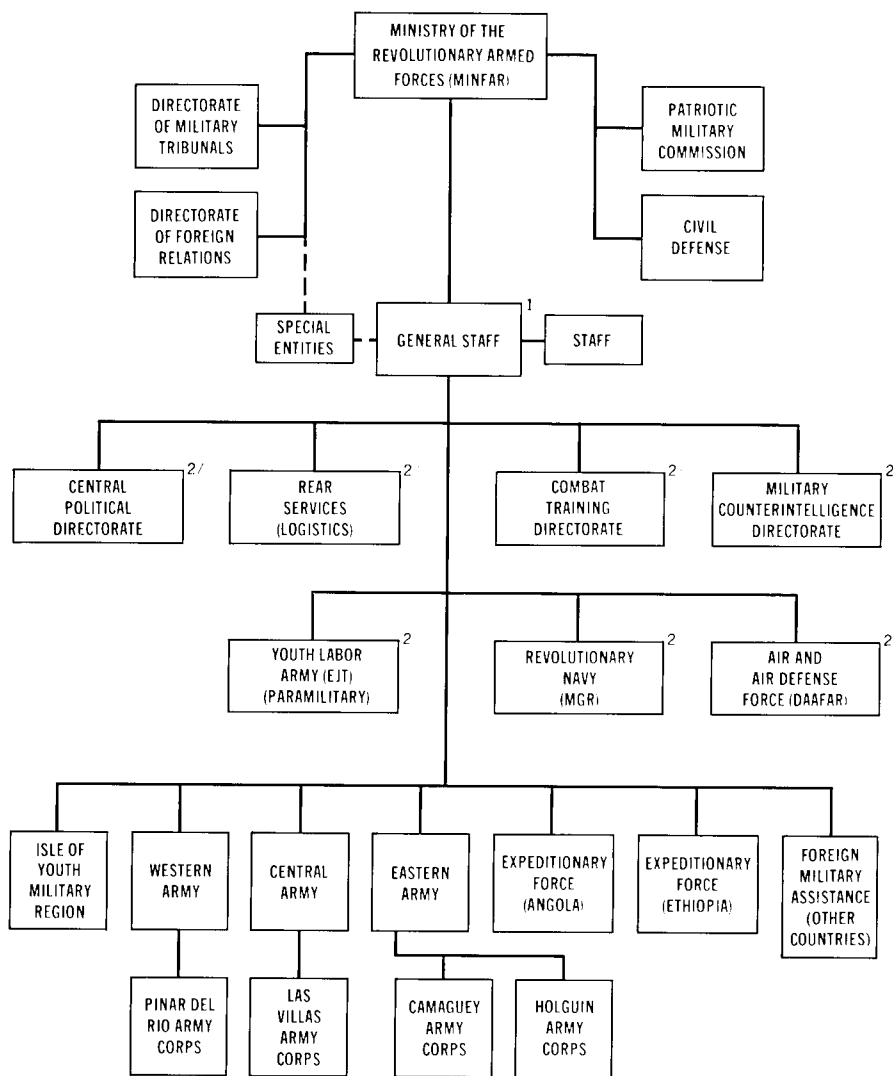

--- Information on subordination of some of the Special Entities is not available.
 1 Headed by the First Deputy Minister, Chief of the General Staff.
 2 Usually headed by Deputy Ministers, who are chiefs of their respective organizations.

Figure 3. Organization of the Ministry of the Revolutionary Armed Forces (MINFAR).

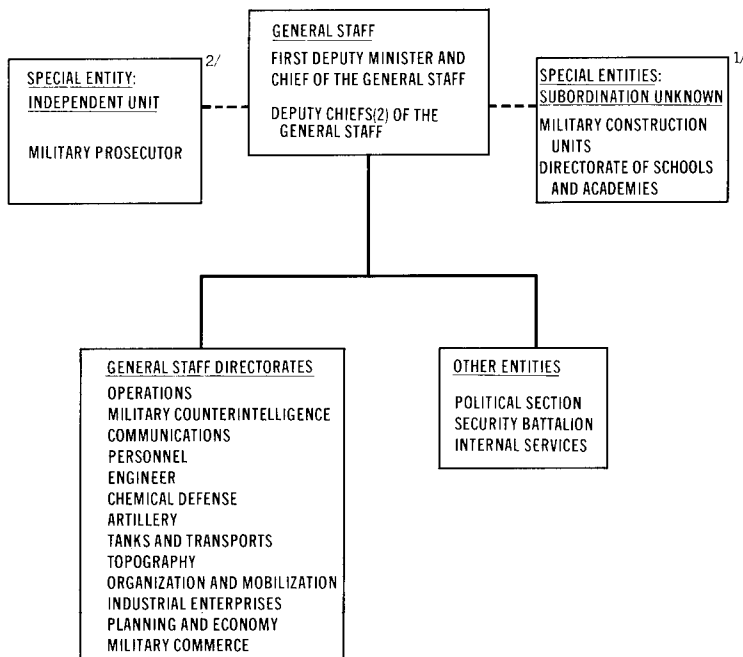

--- Functions probably coordinated by the First Deputy Minister and Chief of the General Staff.

1/ Either or both of these units may be subordinate to the Minister of the Revolutionary Armed Forces.
 2/ Headed by the Vice Attorney General, and subordinate to the Attorney General of the Republic.

Figure 4. Organization of the MINFAR General Staff.

Communist Party's Political Bureau. The Ministry, with central offices located in Havana, has at least five deputy ministers, each of whom head several functional directorates, sections and units charged with implementing policies. MININT activities and personnel throughout Cuba are organized by province and are supervised by Ministry provincial staffs.

4. STRENGTHS AND COMPONENTS OF THE CUBAN ARMED FORCES

MINFAR- and MININT-controlled military and paramilitary forces total approximately between 486,000 and 510,000 (table 1). In addition, MINFAR controls the 100,000 strong Civil Defense forces.

a. MINFAR Forces

The regular and ready-reserve forces in the Army, Revolutionary Navy (MGR), and Air and Air Defense Force (DAAFAR) total between 197,000 and 210,000 personnel. The well-trained ready reserves are included with regular forces because they are combat ready and could be mobilized within 4 hours. A significant portion of Cuban Forces in Africa are ready reserves. The 175,000 to 200,000 other reservists are not as combat ready. The 100,000-strong paramilitary Youth Labor Army (EJT) is a large manpower pool and could aid MINFAR in defending the island. The Civil Defense forces would be responsible primarily for population control, rear area security and disaster relief.

b. MININT Forces

MININT's military and paramilitary forces total 13,800 to 19,000 personnel. The two MININT military units, the Special Troops and the Border Guard Troops (TFG), have been described. The Department of State Security (DSE) would aid especially in internal security and counterintelligence matters.

MININT has several other groups, such as the National Revolutionary Police (PNR), the Firefighting and Fire Prevention Directorate, and the Prison Guard Directorate, which are not counted in the above totals. In addition, there are two civilian auxiliaries which assist the Border Guard Troops: the Border Militia and the Sea Watchers Detachments. Information concerning the number of personnel in these two lightly armed units is not available.

5. METHODS OF UNIT IDENTIFICATION

MINFAR uses several methods of unit identification (MININT unit identification is discussed in chapter 2, section G). Its three armies and the four corps, as well as the principal MGR and DAAFAR commands, usually are identified by a name which corresponds to either a geographical or territorial region or province (examples: Western Army, Las Villas Army Corps, Western Naval Flotilla and Western Air Brigade). The armies and corps in Cuba may also be identified by a one-digit number (example: the First (I) (Eastern) Army). Most of the ground force units below army and corps may also be identified by Arabic numbers of one, two or three digits (example: the 50th Division).



Women officers and NCOs are assigned to combat support and combat service support units in FAR. They are active in MININT and also are an important part of the civilian work forces for both FAR and MININT.

Table 1
Approximate Strength of the Cuban Armed Forces

1. MINFAR Forces

a. Regular and ready reserves:

(1) Army: regular and ready reserves 175,000–185,000

(2) Revolutionary Navy (MGR): regular 10,000

ready reserves unknown

(3) Air and Air Defense Force (DAAFAR):
regular and ready reserves 12,000– 15,000

Total regular and ready reserves: 197,000–210,000

b. Other reservists: 175,000–200,000

c. Youth Labor Army (EJT) (paramilitary) 100,000

MINFAR military and paramilitary forces: 472,000–510,000*

2. MININT Forces

a. Military:

(1) Special Troops 800– 1,000

(2) Border Guard Troops (TGF) 3,000

Total MININT military forces: 3,800– 4,000

b. Others: Department of State Security (DSE) 10,000– 15,000

Total MININT military and other forces: 13,800– 19,000

Total MINFAR and MININT forces: 485,800–529,000*

*In addition, MINFAR controls the Civil Defense force (militia), which has approximately 100,000.

Since about 1975, MINFAR has been awarding honorific names; for example, the Central Missile Brigade, a DAAFAR unit, is also known as the "Santa Clara Battle Brigade." These names are awarded after the designated units achieve predetermined scores in combat and political training.

MINFAR uses another method of unit identification, modeled after the Soviet military system, in which each military unit is assigned a four- or five-digit Arabic numeral called a Military Unit Number (MUN). MUNs are the most common designation used and most of the troops know their unit only by the MUN. Numbers in the 9,000 series are for major combat service support units which MINFAR designates as "paramilitary" units. They are subordinate to units of the General Staff, armies and corps, MGR and DAAFAR. Examples include: the General Staff's Directorate of Military Commerce, and the MGR's General Repair Depot. Numbers below 9,000 are assigned to regular and reserve units which are battalion size or larger, as well as to independent, specialized or headquarters units down to platoon size. Five-digit MUNs are assigned to the paramilitary EJT. In some cases, the only information known about a unit is its MUN.

6. MILITARY OBLIGATIONS

a. *Definitions*

Cuba has a comprehensive and strictly enforced compulsory military obligation law. The August 1973 Law of General Military Service mandates that all Cuban male citizens will serve either in active military service for at least 3 years or in the reserve or in both sometime between the first of January of their 16th year and the 31st of December of their 50th year. Those who are in the active military service are called "military men" and those in the reserves are called "reservists." "Prerecruits" are those aged 16 to 28 who have registered for but have not performed their active military service. Women can enlist after their 16th birthday, and those women who have special training can be incorporated into the reserves until age 40.

The law states that there are two categories of reserve, first reserve and second reserve. In practice, most first reservists train approximately 45 days a year regardless of age, and some may also train a few hours one day a week and all day Sunday once a month. Second reservists usually are not called up for military training. MINFAR has the authority to transfer those in the active military service to the reserve and to call reservists to active military service for as long as is necessary.

The August 1973 Law of Social Service states that those who have attended institutions of higher education for technical, scientific or cultural studies must serve the country for up to 3 years in assignments employing their special skills. These personnel are often assigned to ministries to perform their compulsory government service.

A few are exempted from the military service because they have been declared physically or mentally handicapped by the recruitment board, and some are allowed to defer their military service to complete their studies. Deferments can also be arranged for personnel who are temporarily incapacitated by a serious illness, or if they are the sole supporter of two or more children under 21 years of age.

b. Implementation

An elaborate bureaucratic structure which extends from the national level down to the factories and schools implements the military obligation laws. At the top is the Directorate of Organization and Mobilization on the MINFAR General Staff. Below this level are 14 provincial military committees which control the 168 municipal military committees. The 169th municipality, the Isle of Youth, is directly controlled by the national government. The municipal committees are responsible for registering draftees and for supervising prerecruit training. Municipal committees also control the assignment of reservists to units and supervise the training of reservists who are not assigned to units. Registration sections are also located in schools and factories.

Military obligation for all males is illustrated in figure 5. At the time of registration, each individual is given a military certificate which he must maintain until completion of his military obligation. A municipal military committee determines who will be drafted according to established quotas and the individual's status. Draft calls are held semiannually, during July-August and January-February.

**Section B—Foreign Military Ties;
Cuban Communist Party Control and Indoctrination;
and Civilian-Military Ties**

1. FOREIGN MILITARY TIES

a. Dependence on the Soviet Union

Cuba is dependent on Warsaw Pact countries for military aid, principally the USSR. It has military agreements with the Soviet Union and with other Socialist countries. The Cuban military uses Soviet tactics, doctrines and organizational principles and depends on the Soviets for much of its technical training. As of early 1979, the number of Soviet civilian and military personnel working with the Cuban military as instructors, advisers and technicians is estimated to be 2,000. Thousands of Cubans have also trained in the Soviet Union.

b. International Organizations and Agreements

Cuba is a member of the United Nations but its membership in the Organization of American States (OAS) was suspended in 1964. Although Cuba

Year of 16th Birthday
 Male military obligation begins.
 Every male must register with local
 registration board.
 He receives military certificate.

Active Military

Army/DAAFAR Reserves

Social Service

EJT/MININT

Army, MGR, DAAFAR

Not called to
 active service

Army/DAAFAR
 Reserve Officers

Social Service

Prerecruit tng
 (5-10 mo.) part-
 time while civ.

Prerecruit tng
 (5-10 mo.) part-
 time while civ.

Basic tng
 w/EJT or
 MININT.

45-60 days basic
 tng in Army,
 MGR or DAAFAR.

May be assigned
 to Army or
 DAAFAR reserve
 unit or to man-
 power pool.

Receives military
 tng while
 attending
 selected senior
 high school and
 universities.

Receives civilian
 technical/spe-
 cialized tng (example
 doctors, teachers,
 economists).

Takes Military Oath. Begins
 3-year obligation. Receives
 specialized tng and/or unit
 assignment.

Graduates as
 Reserve Officer.

(If not called up
 for active military
 service).
 Serves up to 3 yrs
 in a Ministry (which
 could be MINFAR) in
 his specialty.
 Completes social
 service obligation.

Completes active mil obligation.

Immediately
 registers w/
 local mil
 board for
 assignment
 to Army or
 MININT 2/
 reserve unit
 or to man-
 power pool.

Immediately
 registers w/
 local mil
 board for
 assignment
 to Army/MGR/
 DAAFAR reserve
 unit or to
 manpower pool.

Immediately
 registers w/
 local mil board
 for assignment
 to reserve Army/
 DAAFAR unit or
 to manpower
 pool.

Immediately
 registers w/local
 mil board for
 assignment to
 reserve unit or
 to manpower pool.

Trains annually.
 May be called to
 active duty.

Year of 50th Birthday
 Male military obligation ends.
 (EXCEPT: No age limit for
 reserve officers).

ratified the 1947 hemispheric Rio Treaty of Reciprocal Assistance in December 1948, the present government does not consider itself bound by the terms of that Treaty. Cuba is not a member of the Warsaw Pact although it has sent military observers to its maneuvers.

On 24 June 1966, Cuba ratified the June 1925 Geneva Protocol prohibiting the use in war of asphyxiating and poisonous gases and of bacteriological agents in warfare. Cuba has also ratified the four international agreements for the protection of war victims signed at the Geneva Convention of 1949. (These four agreements include treatment of the wounded and sick, the treatment and repatriation of war prisoners, and the protection of civilian persons in times of war.) On 21 April 1976, Cuba ratified the Bacteriological (Biological) and Toxin Weapons Convention of 10 April 1972; however, Cuba has refused to ratify the Treaty for the Prohibition of Nuclear Weapons in Latin America, drawn up in Tlalteloco, Mexico, in February 1967.

c. Foreign Military Missions

Cuba has hosted military delegations from various countries. It has sent military advisers to many countries in Africa, Latin America and the Middle East.

Cuba's most notable foreign involvements are in Angola and Ethiopia. Cuban involvement in Angola dates back to 1965 when the Cubans began training members of the Popular Movement for the Liberation of Angola (MPLA) in both Cuba and the Congo. Since late 1975, Cuba, with significant logistical support from the Soviet Union, has stationed as many as 20,000 military personnel, plus several thousand civilian advisers, in Angola. In late 1977, Cuba began to send several thousand military personnel to Ethiopia to aid that country's retrieval of the Ogaden region which Somalia had seized. By March 1978, Cuba had sent approximately 17,000 military personnel, most of whom played a key role in Ethiopia's regaining of the Ogaden region. In view of the Cuban presence in Angola, Ethiopia and other countries, the Cubans are committed to an active involvement especially in Africa for at least several more years.

2. CUBAN COMMUNIST PARTY CONTROL AND INDOCTRINATION

The Cuban Communist Party (PCC), the nation's only political party, is unquestionably the most influential organization in Cuba. The PCC and its youth group, the Union of Young Communists (UJC), are active at all levels of the civilian and military establishments. The leaders believe that a strong military, steeped in Marxist-Leninist ideology, is crucial not only to Cuba's defense against external enemies, but also to the construction of a Socialist society. Political indoctrination at all levels stresses military discipline and the necessity for every person to defend the fatherland in any situation regardless of the cost. The indoctrination and tight PCC control have produced an extraordinary cohesion within the armed forces and unparalleled obedience to the regime.

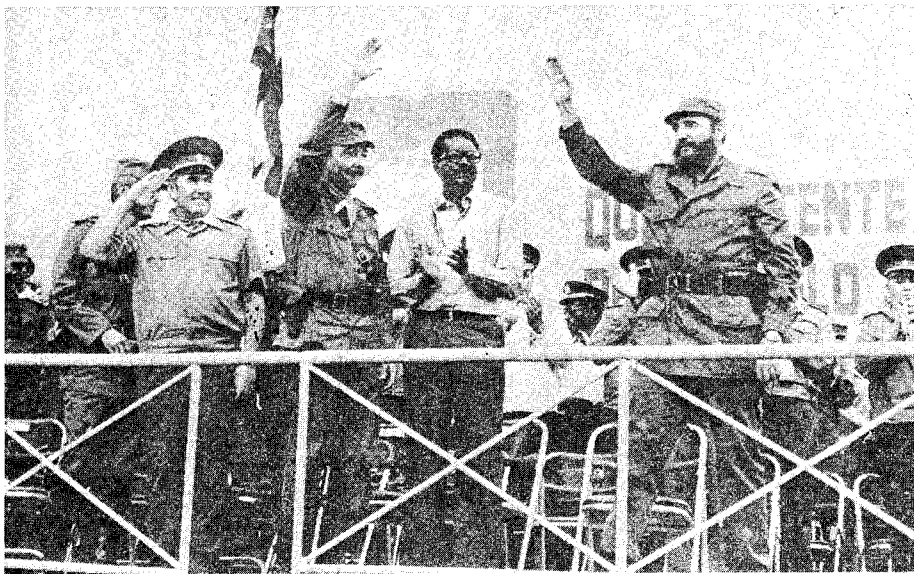

Left to right: (Then) First Deputy Minister of the USSR and Chief of the Soviet Army and Navy Army General Viktor Kulikov, Minister of the Revolutionary Armed Forces General Raul Castro, Angolan Prime Minister Lopo de Nascimento, and Commander in Chief Fidel Castro observe the "20th Anniversary Maneuvers" held in early December 1976 in Camaguey Province.

a. *Interlocking Party and Military Bureaucracies*

The PCC organization within the military parallels the military hierarchy. The Party acts to reinforce the command structure rather than to compete with it. Thus, the Cuban Government, like the Soviet and other Communist countries, have interlocking military and Party bureaucracies in which almost all military officers are also PCC members. This dual structure reaches from the very top of the government military structure down to the squad level. Fidel and Raul Castro hold the top positions in the Party, civilian and military organizations.

Since almost all the military commanders are PCC members, the Party functions as an agency within the military and not as an institution penetrating from the outside. Nonmilitary PCC members have no authority within MINFAR and consequently the military enjoys a great deal of autonomy.

b. *Organization and Functions of the Central Political Directorate*

The MINFAR Central Political Directorate, usually headed by a deputy minister who is a member of the Central Committee, is responsible for political

indoctrination, public relations, propaganda and PCC-MINFAR relations (figure 6). The Central Political Directorate supervises the activities of unit political sections and political officers (oftentimes called Political Commissars). All units down to battalion level have political sections commensurate with the size of the unit. At the company and platoon levels, there are only political officers. Additionally, each squad-size unit has a political representative. The authority of the political section chiefs (from division down to battalion) and political officers (at the lower levels) equals that of the unit commander in all but military decisions. In the event a company or platoon-level unit commander becomes incapacitated, the political officer reportedly has the authority to designate his successor. The political officer, however, cannot designate himself.

At every level the Party and its youth wing, the Union of Young Communists (UJC), directly influence all aspects of troop life. PCC and UJC representatives actively participate in the combat training programs, conduct indoctrination classes, and monitor unit morale. The platoon-level political officers file regular reports on each unit member's behavior. These reports are an important consideration in military promotions.

c. Political Indoctrination

Political indoctrination classes are generally held weekly for about 2 hours. However, those in basic training receive daily instruction. The instructors, who include unit commanders and their deputies as well as political officers,



A Tank (Armored) Division holds a meeting of its Cuban Communist Party members. The Party exercises strong control in the military through its Political Officers.

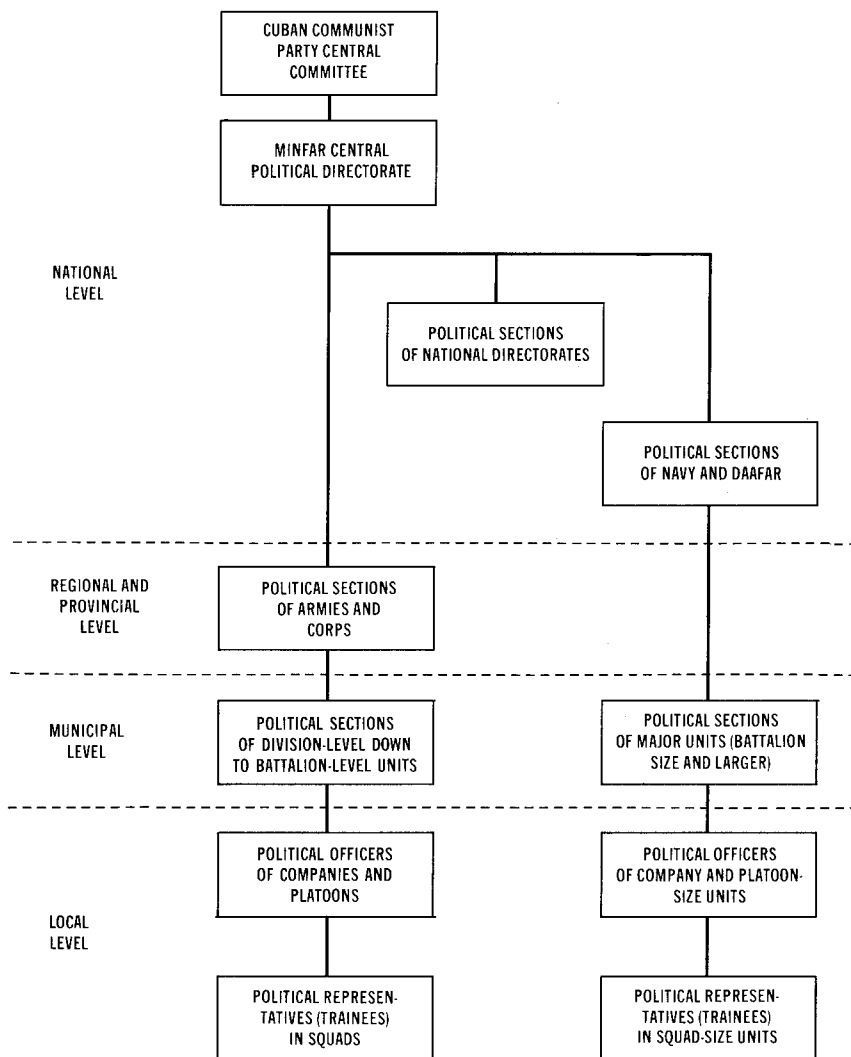

Figure 6. Cuban Communist Party Control in MINFAR.

invariably are members of either the PCC or the UJC. Generally, officers instruct officers, and NCOs teach other NCOs and enlisted personnel. MINFAR's Central Political Directorate determines the programs for the classes.

Instruction is based on speeches made by high-level Cuban and Soviet Party officials, as well as Marxist-Leninist literature. Subjects frequently taught include Marxist-Leninist doctrine, military discipline and loyalty to the regime, the Cuban fight for independence, Cuban foreign policy, and the struggle against Western imperialism.

3. CIVILIAN-MILITARY TIES

The Cuban Government believes that culture, politics and the military are inseparable. Strong civilian-military bonds are stressed to reinforce the Cuban philosophy that all Cuban citizens are soldiers defending their Socialist country. The government has developed extensive ties between the civilian and military sectors to encourage mutual respect.

The principal organization charged with promoting civilian-military ties is the Patriotic Military Commission, an interministerial agency headed by a MINFAR colonel who reports directly to General Raul Castro. MINFAR has a Patriotic Military Work Group, also headed by a colonel, which implements the Commission's policies for the military. The Group has organized about 1,000 military interest clubs for children as well as numerous military sports clubs for teenage youths. The Group also supervises prerecruit training and reserve officer training in selected senior high schools and universities.

The Committees for the Defense of the Revolution (CDR), the largest organization in Cuba with a membership of about one-half of the total population, also promotes ties between the military and its members.

MINFAR and MININT personnel can vote for delegates for the municipal, provincial and national assemblies of People's Power, which are, in theory, the voice of the people. MINFAR and MININT personnel also can be elected as representatives to the assemblies at any of the three levels.



A high ranking Army officer receives his ballot in a local election held in October 1976. All military personnel 16 years of age and older can vote in elections and participate in representative assemblies.

CHAPTER 2 THE CUBAN GROUND FORCES

Section A—Organization of the Cuban Army

1. MISSIONS AND CAPABILITIES

a. *Missions*

The missions of the Cuban Army are to provide territorial defense, to aid in maintaining internal security, and to provide military and/or combat assistance to selected foreign countries or groups.

b. *Capabilities*

The Army is capable of providing a tenacious defense of the island. It has a very limited quick-strike capability off the island because it lacks sufficient sea and air transport mobility. However, the experience in Africa has demonstrated that by using its merchant fleet and with sufficient Soviet support, Cuba can undertake and sustain a long-term deployment and supply effort.

Army personnel are well schooled in individual combat skills, and thousands of troops have now had actual combat experience in Africa. Since personnel are rarely cross-trained, they are very dependent upon key personnel. Should the key personnel be incapacitated, particularly in the command structure, the remaining members of the unit would not have the training necessary to fill vacated positions and to function effectively. The average Cuban soldier has acquired little knowledge outside of that needed for his own specialty.

The Cuban Army is capable of maintaining and repairing almost all of its equipment. It is, however, almost completely dependent upon outside sources, particularly the Soviet Union, for equipment, spare parts and POL. Cuba does produce some ammunition and explosives.

2. STRENGTH

The Cuban Army is composed of 175,000 to 185,000 regular and ready reservists. The ready reservists are included in the regular forces because they are combat ready and can be mobilized within 4 hours. In addition, there is a manpower pool of several tens of thousands of reservists who receive training every year.

3. COMMAND AND CONTROL

The First Deputy Minister and Chief of the General Staff exercises direct control over the Revolutionary Armed Forces (figure 3). He is assisted by the members of his General Staff, the Deputy Ministers, and by the headquarters of the Isle of Youth Military Region, and the Western, Central and Eastern Armies (figure 7). The Isle of Youth Military Region is probably division size. There are four corps. The Western Army controls Pinar del Rio Army Corps, composed of



Cuban infantry troops.

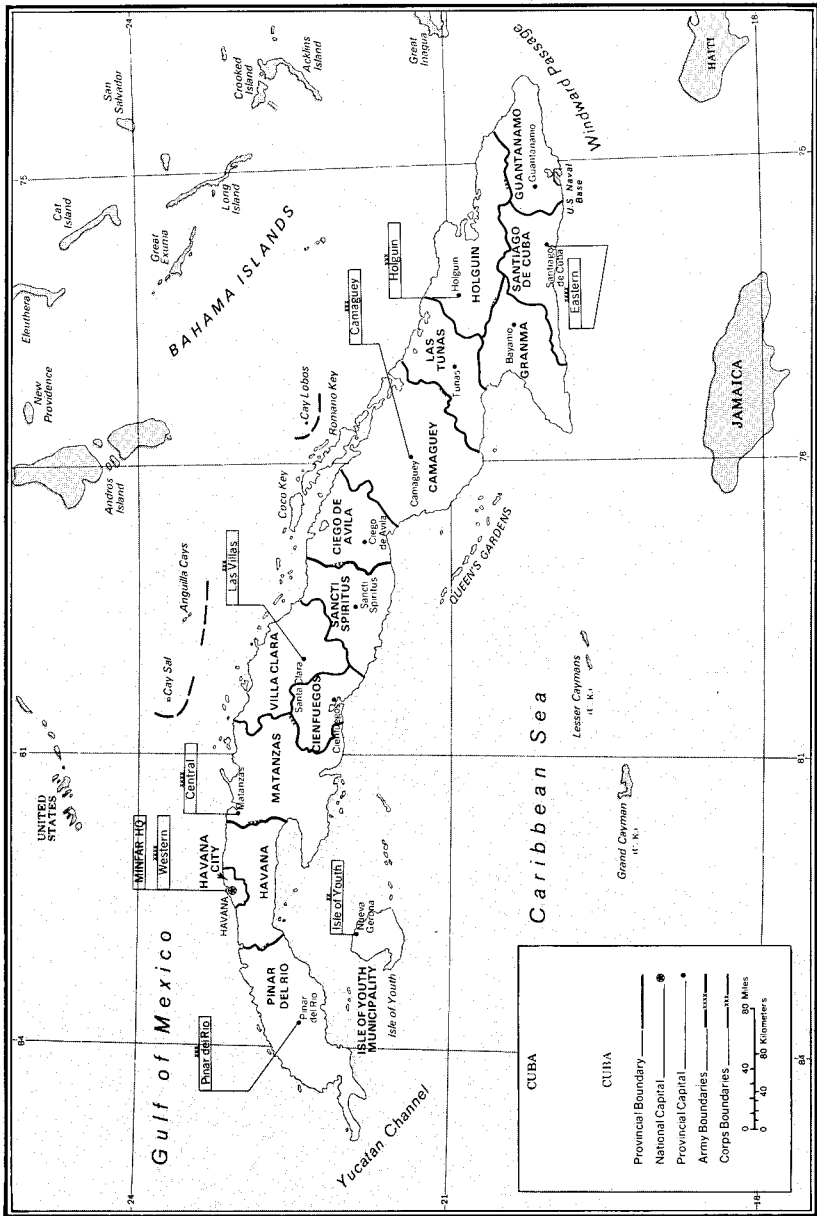

DD82680 62/79

Figure 7. Locations and boundaries of military areas of responsibilities.

units in Pinar del Rio Province. (The Western Army also directs the Havana Garrison, which is an administrative headquarters for units in the Havana City Province area. Since it does not appear to be a combat command, it is not depicted in figures 3 or 7.) The Las Villas Army Corps, subordinate to the Central Army, controls the units in Villa Clara, Cienfuegos and Sancti Spiritus Provinces. The Eastern Army controls the Camaguey Army Corps composed of units in Camaguey and Ciego de Avila Provinces, and the Holguin Army Corps, whose units are located in Holguin and Las Tunas Provinces. All foreign deployments are controlled by MINFAR Headquarters.

In the event of war, or in response to real or perceived threats to its national security, MINFAR Headquarters in Havana would operate through the framework of the three armies (that is, the Western, Central and Eastern Armies) and the Isle of Youth Military Region. Each army and the Isle of Youth Military Region would control all ground forces and most paramilitary units (such as the Youth Labor Army (EJT)) in its area of responsibility. MINFAR Headquarters probably would retain control of Navy and DAAFAR units in order to assign the resources where needed.

The command responsibility during crisis situations for the four corps in Cuba is not clear. Each corps headquarters may report directly to MINFAR Headquarters rather than its present army headquarters.

4. DEPLOYMENT

Most Cuban Army units are located in-country and are deployed generally in conformity with the population distribution. Cuba does have about 37,000 troops in Angola and Ethiopia. Additionally, Cuba is deploying military assistance groups to several other African and Middle Eastern countries.

5. TABLES OF ORGANIZATION AND EQUIPMENT

a. *General*

Cuban tactical formations are modeled on conventional Soviet tactics with significant adjustments for differences in equipment and lower strength levels. The Tables of Organization and Equipment (TOE) of combat and combat support units are illustrated in appendixes A through L. In practice, there are significant variations in the manning, equipment and composition of units. The TOE of units in the five provinces of Havana, Havana City, Santiago de Cuba, Holguin and Guantanamo are better represented by the accompanying appendixes than are the TOE of units in the other provinces. In combat situations, Cubans tailor their units in order to adapt to the local enemy and terrain conditions.

b. *Manning levels*

The Cubans have three manning levels for their units:

Category I – Units manned at full strength by active duty soldiers.

Category II – Units partially manned by active duty soldiers which are augmented by reserve forces.

Category III – Units composed of active duty cadre which are augmented by reserve forces.

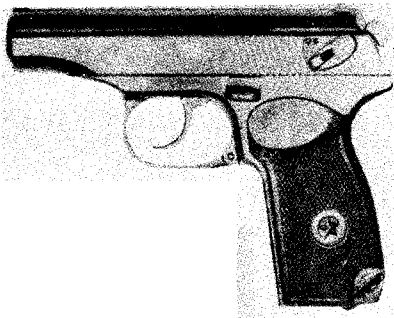

a. 9-mm pistol, Makarov (PM).



b. 7.62-mm Modernized Assault Rifle
Kalashnikov (AKM).

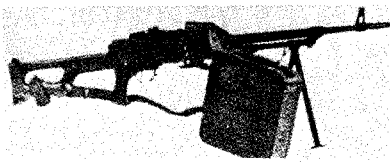

d. 7.62-mm general purpose
machinegun, Kalashnikov (PK).

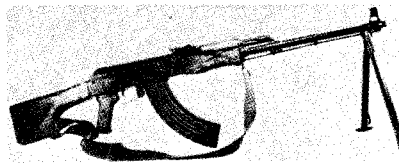

c. 7.62-mm light machinegun, Kalashnikov
(RPK).



e. Antitank grenade launcher (RPG-7).

Principal Cuban small arms

The reserves are well integrated into the regular army and because of this integration, it is often difficult to determine whether units are regular or reserve or a combination of both. Most of the country's active divisions are Category II units.

c. *The Western, Central and Eastern Armies*

The Western, Central and Eastern Armies are the largest units in the Cuban Army. There is no standard organization for the three armies. The Western and Eastern Armies are much larger than the Central Army. The army portrayed in appendix A is constructed to resemble the Western and Eastern Armies. The representative army consists of seven infantry divisions (three of which are reserve), a mechanized infantry division, an armored division, a corps, as well as combat support and combat service support units, totaling about 71,500 personnel.

d. *The Corps*

There does not appear to be any standard organization for the four corps. The representative corps in Cuba is comprised of three infantry divisions, two of which are reserve, plus combat support and combat service support units totaling about 17,300 (appendix A). The forces in Angola and Ethiopia and other units deployed overseas are composed primarily of personnel and units taken from all three armies and their subordinate corps. The majority of the specially organized units in Angola and Ethiopia are probably either regiments or reinforced regiments.

e. *Combat Units*

Combat forces under the control of an army consist of infantry, mechanized infantry and armor units. All combat units are modeled along Soviet organizational principles, but with reduced manning and equipment levels. The organizational structures of representational combat units are depicted as follows:

Infantry Division	Appendix B
Infantry Regiment	Appendix C
Infantry Battalion	Appendix D
Mechanized Infantry Division	Appendix E
Mechanized Infantry Regiment	Appendix F
Mechanized Infantry Battalion	Appendix G
Armored Division	Appendix H
Tank Regiment	Appendix I
Tank Battalion	Appendix J

PREFACE

This publication has two purposes: to provide a concise and readable synopsis of the Cuban Armed Forces, and to provide commanders and staff officers with sufficient information to conduct realistic training exercises for their units. Individual chapters are devoted to the Army, the Navy, the Air and Air Defense Force, Cuban military strategy and tactics, and uniforms, awards and decorations. Information on some of the paramilitary forces is included because of their role in support of the Cuban Armed Forces.

This study is based only on unclassified sources. Users who require more specific information should consult the appropriate classified DIA publications.

Addressees are requested to forward information which will supplement or correct the publication. Questions and comments should be referred in writing to the Defense Intelligence Agency (ATTN: DB-3E), Washington, D.C. 20301.

Accession For	
NTIS CRA&I	<input checked="" type="checkbox"/>
DTIC TAB	<input type="checkbox"/>
Unannounced	<input type="checkbox"/>
Justification	
By	
Distribution /	
Availability Codes	
Dist	Avail and/or Special
A-1	

TABLE OF CONTENTS

	Page
SUMMARY	xiii
FOREIGN ABBREVIATIONS	xv
CHAPTER 1—THE CUBAN ARMED FORCES	1-1
Section A—General	1-1
1. HISTORICAL DEVELOPMENT	1-1
2. MISSIONS AND CAPABILITIES	1-5
3. NATIONAL ORGANIZATION OF THE ARMED FORCES ...	1-6
4. STRENGTHS AND COMPONENTS OF THE CUBAN ARMED FORCES	1-10
5. METHODS OF UNIT IDENTIFICATION	1-10
6. MILITARY OBLIGATIONS	1-13
Section B—Foreign Military Ties; Cuban Communist Party Control and Indoctrination; and Civilian-Military Ties	1-14
1. FOREIGN MILITARY TIES	1-14
2. CUBAN COMMUNIST PARTY CONTROL AND INDOCTRINATION	1-16
3. CIVILIAN-MILITARY TIES	1-20
CHAPTER 2—THE CUBAN GROUND FORCES	2-1
Section A—Organization of the Cuban Army	2-1
1. MISSIONS AND CAPABILITIES	2-1
2. STRENGTH	2-1
3. COMMAND AND CONTROL	2-1
4. DEPLOYMENT	2-4
5. TABLES OF ORGANIZATION AND EQUIPMENT	2-4
6. IDENTIFICATION	2-9
Section B—Equipment	2-9
Section C—Personnel	2-11
1. THE CUBAN SOLDIER	2-11
2. MANPOWER POOL	2-12
3. RANKS AND TERMS OF SERVICE	2-12
4. PROMOTION POLICIES, PAY, ALLOWANCE, AND BENEFITS	2-14
5. LEAVE AND PASSES	2-16
6. RECREATION	2-16
7. INCENTIVES AND DISCIPLINE	2-16

	Page
Section D—Training	2-18
1. GENERAL	2-18
2. PRERECRUIT TRAINING	2-21
3. BASIC TRAINING	2-22
4. SPECIALIST TRAINING	2-23
5. OFFICER TRAINING	2-23
6. YEARLY TRAINING CYCLE	2-26
7. FOREIGN MILITARY TRAINING	2-28
Section E—Logistics	2-28
1. GENERAL	2-28
2. LOGISTICS PRINCIPLES	2-29
3. ORGANIZATION FOR LOGISTICS AND MAINTENANCE	2-30
4. PROCEDURES FOR DISTRIBUTION OF REAR SERVICES ITEMS	2-31
5. MAINTENANCE, REPAIR AND RECOVERY	2-35
6. SUPPLY PROCEDURES FOR AMMUNITION	2-36
7. PRISONERS OF WAR (POWs)	2-37
Section F—The Army Reserves	2-37
1. GENERAL	2-37
2. RESERVE ORGANIZATION AND MOBILIZATION	2-39
3. TRAINING	2-40
Section G—MINFAR Paramilitary and MININT Forces	2-41
1. MINFAR PARAMILITARY UNITS	2-41
2. MININT MILITARY FORCES	2-44
3. DEPARTMENT OF STATE SECURITY (DSE)	2-50
Section H—Civil Defense	2-51
1. GENERAL	2-51
2. MISSIONS AND CAPABILITIES	2-51
3. STRENGTH	2-51
4. COMMAND, CONTROL AND ORGANIZATION	2-51
5. COMPOSITION	2-52
6. TRAINING AND EQUIPMENT	2-52

	Page
CHAPTER 3—THE CUBAN REVOLUTIONARY NAVY	3-1
Section A—Organization	3-1
1. HISTORICAL BACKGROUND	3-1
2. MISSIONS AND CAPABILITIES	3-1
3. STRENGTH	3-4
4. COMMAND AND CONTROL	3-5
5. IDENTIFICATION	3-5
Section B—Equipment and Logistics	3-6
1. NAVAL VESSELS	3-6
2. MAINTENANCE	3-6
Section C—Personnel and Training	3-6
1. PERSONNEL	3-6
2. TRAINING	3-9
Section D—Reserves and Mobilization	3-12
CHAPTER 4—THE CUBAN AIR AND AIR DEFENSE FORCE	4-1
Section A—Organization	4-1
1. COMPOSITION AND STRENGTH	4-1
2. HISTORICAL BACKGROUND	4-1
3. MISSIONS AND CAPABILITIES	4-1
4. COMMAND AND CONTROL	4-3
5. IDENTIFICATION	4-3
Section B—Equipment and Logistics	4-3
1. EQUIPMENT	4-3
2. SUPPLY	4-5
3. MAINTENANCE	4-5
Section C—Personnel and Training	4-5
1. PERSONNEL	4-5
2. TRAINING	4-7
Section D—Reserves and Mobilization	4-8
Section E—Civil Aviation and Air Fields	4-10
1. CIVIL AVIATION	4-10
2. AIRFIELDS	4-10

	Page
CHAPTER 5--MILITARY STRATEGY AND TACTICS	5-1
Section A--Introduction	5-1
1. GENERAL CONCEPTS	5-1
2. TERRAIN AND CLIMATE	5-1
3. SETTLEMENT PATTERNS	5-9
Section B--Basis of Tactics	5-9
1. COMMAND, CONTROL AND COMMUNICATIONS	5-9
2. TACTICAL PRINCIPLES	5-11
3. RECONNAISSANCE	5-13
4. FIREPOWER	5-16
5. PRINCIPLES OF COMBAT	5-22
Section C--Offensive Operations	5-25
1. MANEUVER FORMS AND OFFENSIVE ACTIONS	5-25
2. FORMATIONS AND SCHEMES OF MANEUVER FOR OFFENSIVE TACTICAL SITUATIONS	5-31
3. FRONTAGES	5-31
4. DIVISIONS IN OFFENSIVE OPERATIONS	5-42
Section D--Defensive Operations	5-49
1. GENERAL	5-49
2. FORMS AND TYPES OF DEFENSE	5-51
3. ORGANIZATION OF DEFENSE BELTS	5-52
4. CONDUCT OF THE DEFENSE	5-62
Section E--Retrograde Operations	5-65
1. GENERAL	5-65
2. THE WITHDRAWAL	5-66
3. DELAYING ACTION	5-68
4. RETIREMENT	5-68
Section F--Warfare Under Special Conditions	5-69
1. AMPHIBIOUS OPERATIONS	5-69
2. AIRBORNE AND AIRMOBILE OPERATIONS	5-69
3. FIGHTING IN BUILT-UP AREAS	5-69
4. MOUNTAIN WARFARE	5-73
5. JUNGLE WARFARE	5-73
6. GUERRILLA WARFARE	5-74
Section G--Naval Tactics	5-74

Cuba's inventory probably still includes equipment acquired from the United States prior to 1959, as well as limited amounts of Chinese weapons including the 75-mm recoilless rifle and pistols that were acquired during the 1960s.

The Soviet and East European equipment is usually easy to maintain. Many of the models have interchangeable parts within the model lines. The equipment is maintained at effective operational levels.

The technical characteristics and illustrations of the common equipment presently in the Cuban Army inventory are given in appendix M.

Section C—Personnel

1. THE CUBAN SOLDIER

a. *Enlisted Personnel*

The Cuban soldiers are literate and well trained in their specialty. They are politically indoctrinated, well disciplined and loyal. They are accustomed to simple living conditions.

Morale within the military is believed to be high; however, Cubans do not openly criticize the military for fear of punishment. An elaborate system of civilian-military organizations has been established to reinforce and strengthen the feelings of loyalty and admiration for the military.



A representative cross-section of the racial characteristics of Cuban soldiers. They are loyal, literate, healthy and well trained in their specialty.

Almost all Cubans would defend their homeland without hesitation, particularly against an attack either by the United States or by Cuban exiles. Although the Cuban Government reported that many thousands of Cubans volunteered to fight in Africa, the prospect of service overseas appears to have increased the number of disciplinary problems.

Military service and reserve duty are compulsory for all Cuban males and some females who have special skills. The Cuban Government often penalizes those who do not fulfill their military obligations by restricting their job and promotion opportunities and by preventing them from acquiring some consumer goods, such as refrigerators.

b. *Officers*

The Cuban officer is better educated and more devoted to the military than is the enlisted man. Officers generally are highly motivated, heavily indoctrinated, well trained and accustomed to nonpretentious living conditions. Those who are in their twenties probably have attended military schools since their teenage years, and they are used to an atmosphere of unquestioned obedience. The officer is probably a member of either the Union of Young Communists (UJC) or its parent organization, the Cuban Communist Party (PCC), and is a respected member of the community.

2. MANPOWER POOL

As of 1 January 1978, the total number of Cubans between the ages of 16 and 50 was 4,430,000. Of this total, 2,250,000 were males and 2,180,000 were females. Approximately 1,400,000 of the males and 1,360,000 of the females were fit for military service. The ethnic composition of the armed forces probably reflects that of the general population: 51 percent mulatto, 37 percent white, 11 percent Negro and 1 percent Chinese.

3. RANKS AND TERMS OF SERVICE

a. *Ranks*

Military ranks and chain of command are modeled after the Soviet military system. The rank insignia are illustrated in chapter 6. The highest ranking position is held by Fidel Castro, who is Commander in Chief (equivalent to US General of the Army, see table 2). Raul Castro, the Minister of the FAR, is the second highest; he is the only General. Normally, most of the MINFAR deputy ministers and the commanders of the three armies are major generals. Most of the persons serving their compulsory military service remain privates for their entire 3-year obligation. In print, they are referred to as "S.M.G.," the Spanish initials for "General Military Service," named after the 1973 Law of General Military Service. Also in print, they are often identified by the year they entered the S.M.G.; the 14th calling, for example, refers to personnel entered in 1977 (Cuba instituted Compulsory Military Service in November 1963).

Table 2
Cuban Ground Forces Ranks*

<u>Spanish</u>	<u>Literal Translation</u>	<u>Approximate US Equivalent</u>
Comandante en Jefe	Commander in Chief	General of the Army
General de Ejercito	Army General	General
General de Cuerpo de Ejercito	Army Corps General	Lieutenant General
General de Division	Division General	Major General
General de Brigada	Brigade General	Brigadier General
Coronel	Colonel	Colonel
Teniente Coronel	Lieutenant Colonel	Lieutenant Colonel
Mayor	Major	Major
Capitan	Captain	Captain
Primer Teniente	First Lieutenant	First Lieutenant
Teniente	Lieutenant	Second Lieutenant
Sub-Teniente	Sub-Lieutenant	(No US Equivalent)
Primer Sub-Oficial	First Sub-Officer	Chief Warrant Officer
Sub-Oficial	Sub-Officer	Warrant Officer
Sargento de Primera	First Sergeant	Master Sergeant
Sargento de Segunda	Second Sergeant	Sergeant First Class
Sargento de Tercera	Third Sergeant	Sergeant
Soldado de Primera	First Soldier	Private First Class
Soldado	Soldier	Private

*Ground Forces includes ground elements of DAAFAR, especially the Air Defense Artillery personnel.

The Cubans have adopted branch-of-service insignia as part of the uniform for personnel assigned to several branches including infantry, air force, armor, artillery, and special forces. There are also technical ranks which denote specialization in certain skills, such as engineering, quartermaster, medical, juridical and administrative.

Most Cuban personnel in Africa did not wear ranks on their uniforms. Some officers who insisted on wearing some distinguishing feature were allowed to wrap a piece of red cloth around either the left or right shoulder epaulet.

b. *Terms of Service*

Compulsory military service personnel who decide to become regular enlisted personnel can do so at any time during their 3-year obligatory tour. They are required to sign an agreement to serve 5 years, which includes whatever time they served initially. The compulsory military service personnel are encouraged to become regular enlisted personnel with inducements such as better pay, better uniforms, and more privileges. At least 25 years of service is normally required to qualify for retirement benefits. Officers are also expected to serve a minimum of 25 years. Requests for discharge must be approved by MINFAR headquarters in Havana.

4. PROMOTION POLICIES, PAY, ALLOWANCE, AND BENEFITS

a. *Promotion Policies*

Promotion policies and career development are the responsibility of the Directorate of Personnel (figure 4). Compulsory military service personnel usually are not promoted as long as they remain in that status. Promotions for NCOs are awarded for merit and for completing courses in one's field of specialization. Membership in either the UJC or the PCC often is a consideration in promotions. Promotions are usually awarded to active personnel on 2 December, the anniversary of MINFAR, and to reserves on 16 April, Militia Day (both dates are national holidays).

Direct commission from any enlisted rank is at the initiative of the unit commander, and is based primarily on the individual's outstanding performance. However, these promotions must be approved by MINFAR Headquarters in Havana.

The officer career development program was reorganized and improved in 1975. Presently, lower grade officers are eligible for promotion about every 3 years. Promotions are based on regular efficiency reports which the officer's commander and political officer submit every 6 months. Included in the reports are ratings on political reliability, military competence and advanced schooling. Reportedly, those who have served overseas are promoted more rapidly than those who have not. Membership in either the UJC or the PCC is an unstated requirement for advancement above the rank of captain.

Demotions and discharges can be imposed as punishment for violations of either military or civilian laws.

b. *Pay and Allowance*

Military pay does not include allowances for food or housing (table 3). All privates, many enlisted personnel and some officers are fed, housed and clothed at the military base where they are stationed. Other officers, particularly the higher ranking ones, live off post in apartments or houses.

c. *Benefits*

In late November 1976, the Cuban Government passed the Law of Social Security of the Armed Forces which established guidelines and pay scales for retirement, death and disability benefits for military services. Military service is defined as service by officers and regular enlisted personnel in the FAR, its predecessors, and the EJT. Military personnel assigned to Civil Defense and personnel who are assigned to MININT forces are also covered by the law. Benefits are paid to ex-service members or to their families. Excluded from the law are reservists and civilians working for the FAR who are covered by the civilian social security system.

The amount of the retirement varies according to the combination of years of service (at least 25, reserve time not included), age, rank and position. For example, personnel who retire after age 55 are entitled to 60 percent of

Table 3

Basic Monthly Pay for Selected Ranks of Cuban Ground Forces Personnel

<u>US Equivalent</u>	<u>Basic Monthly Pay</u>	<u>US Equivalent</u>
<i>Rank</i>	<i>(Pesos)*</i>	<i>(Dollars)</i>
Private (S.M.G.)	7	9.24
Private First Class	60	79.20
Staff Sergeant	85	112.20
Sergeant First Class	**	**
Master Sergeant	120	158.40
Warrant Officer	**	**
Senior Warrant Officer	**	**
Sub Lieutenant (No US Equivalent)	**	**
Second Lieutenant	230	303.60
First Lieutenant	**	**
Captain	300	396.00

*One Cuban peso is worth about \$1.32.

**Information not available.

their last pay with an additional 3 percent for each year of active military service beyond the minimum of 25 years. The maximum benefit is 90 percent of the last monthly rate of pay. Personnel who retire before age 55 receive 50 percent of their last pay with an additional 3 percent for each year of additional service beyond 25 years with a maximum benefit of 80 percent of the last monthly rate of pay.

The amount of pay for disability is determined by three factors: the amount of the last monthly pay received for grade and position, the causes and conditions that resulted in the disability, and the degree and type of disability. Pensions paid for reasons of death consist of either a monthly payment or a lump sum payment to the relatives of military or retired personnel. The amount paid is determined by the amount of the last monthly pay received for the grade and position of the deceased, the number of beneficiaries, and the circumstances or causes of death.

5. LEAVE AND PASSES

No leave is permitted during basic training; the recruits, however, are given time off on Sunday afternoon. After completion of basic training, the soldiers are allowed to leave the base from Saturday noon until 0600 Monday morning. Regular personnel are allowed 1 week's vacation every 6 months.

6. RECREATION

During their free time, all military personnel are encouraged to increase their political awareness and maintain their physical condition. To accomplish these goals, MINFAR has established facilities down to at least the battalion level. The facility at the lowest level, sometimes called the "Lenin-Marti Room," is similar to the day rooms at US Army company level. This room contains propaganda posters, books and games such as chess. The next higher facility is the "Regimental Club" which usually is a building that contains game, study and meeting rooms plus some sports facilities. There are also officers and noncommissioned officers clubs. The FAR Main Club, located in Havana City, is open to all MINFAR personnel and their families. The Main Club has facilities for sports, games and studies, and serves as the principal meeting place for important MINFAR conferences.

The Directorate of Combat Training (figure 3) runs the extensive MINFAR sports program. Team sports include baseball, soccer, volleyball, handball and basketball. Other sports include motorcycle racing, track, swimming and scuba diving. Competition in military skills such as rifle and pistol firing and grenade throwing is also encouraged.

7. INCENTIVES AND DISCIPLINE

Commanding officers use a system of incentives and punishment to maintain military discipline. Political officers at all levels hold meetings to encourage self-criticism and to analyze why the unit is or is not meeting its goals.

a. *Incentives*

Incentives and benefits are used to induce the soldier to perform his military services efficiently. Incentives include recognition of outstanding performance and elimination from the soldier's record of previously imposed penalties. Benefits include the awarding of badges, additional leave, and promotions prior to the minimum time established.

b. *Disciplinary Regulations*

FAR disciplinary regulations provide for punishment of officers, NCOs, soldiers and civilian workers. Corrective punishment may be imposed on violators of military discipline and public order only by their superior officers and the said officers may impose only those punishments provided in the regulations. Garrison commanders and commanders of army headquarters are given the right, in certain situations, to impose punishment on soldiers not subordinate to them.

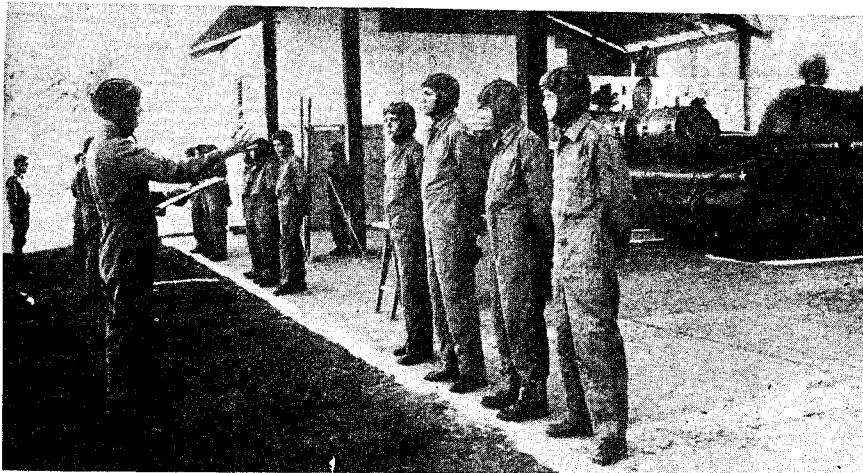

A tank platoon is given instruction; T-54/55s are in the storage shed in the background.
Cuban tankers, like those of the Soviet Union, are generally shorter than average, usually less than 5'6" (1.65 meters).

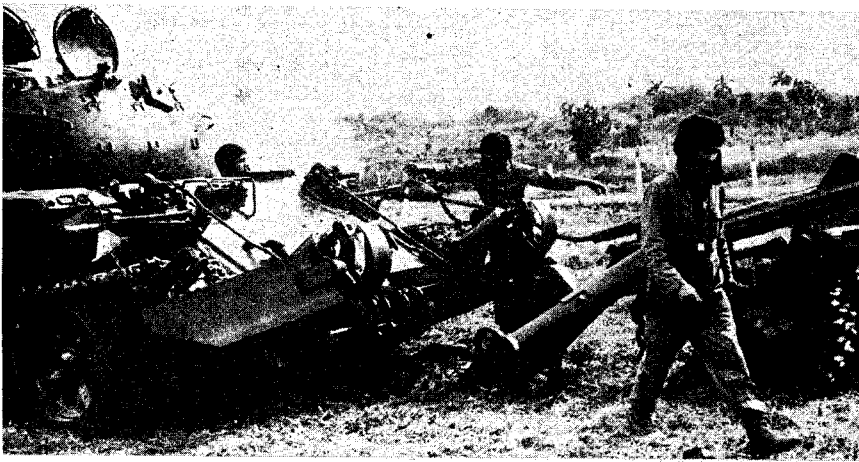

A T-54/55 tank mounted with mine-clearing rollers and plows.

c. Crimes and Punishments

For minor offenses, such as tardiness and laziness, Cuban commanders and political officers first counsel the errant subject to determine the reasons for the offense and to urge improvement in behavior. If the subject does not respond favorably to the counseling, the commander may then impose corrective punishment such as suspension of leave privileges.

Among the most despicable crimes are treason, espionage, murder, cowardice, robbery, bribery, fraud and other crimes that affect the soldier's moral reputation. The principal sentences are:

- death—execution by rifle—for such crimes as treason and murder.
- incarceration for not more than 30 years—for such crimes as robberies, especially those involving violence.
- fine.
- public criticism—a warning.

Alternatives to the above sentences include:

- expulsion.
- demotion.
- loss of military rights and benefits.
- loss of property.

Both the authors and the accomplices of the crime are considered at fault. Sentences depend on the circumstances of the crime. Corrective punishment is put into effect immediately unless there are extenuating circumstances. In these cases, punishment may be delayed for a maximum of 30 days or one may be acquitted of the crime. Implementation of the punishment is not delayed by filing an appeal. An appeal may be submitted only under special circumstances.

Section D—Training

1. GENERAL

Since 1970, the Cuban Army has improved and expanded its training program which is basically Soviet in design and execution. The program emphasized constant repetition. The training produces a physically fit soldier skilled in his specialty, but one who has received practically no information other than that needed to accomplish his mission. Thus, most personnel know little more than what they have been specifically trained to do. Unit training is seldom conducted above platoon level.



Training for fighting in an NBC environment.

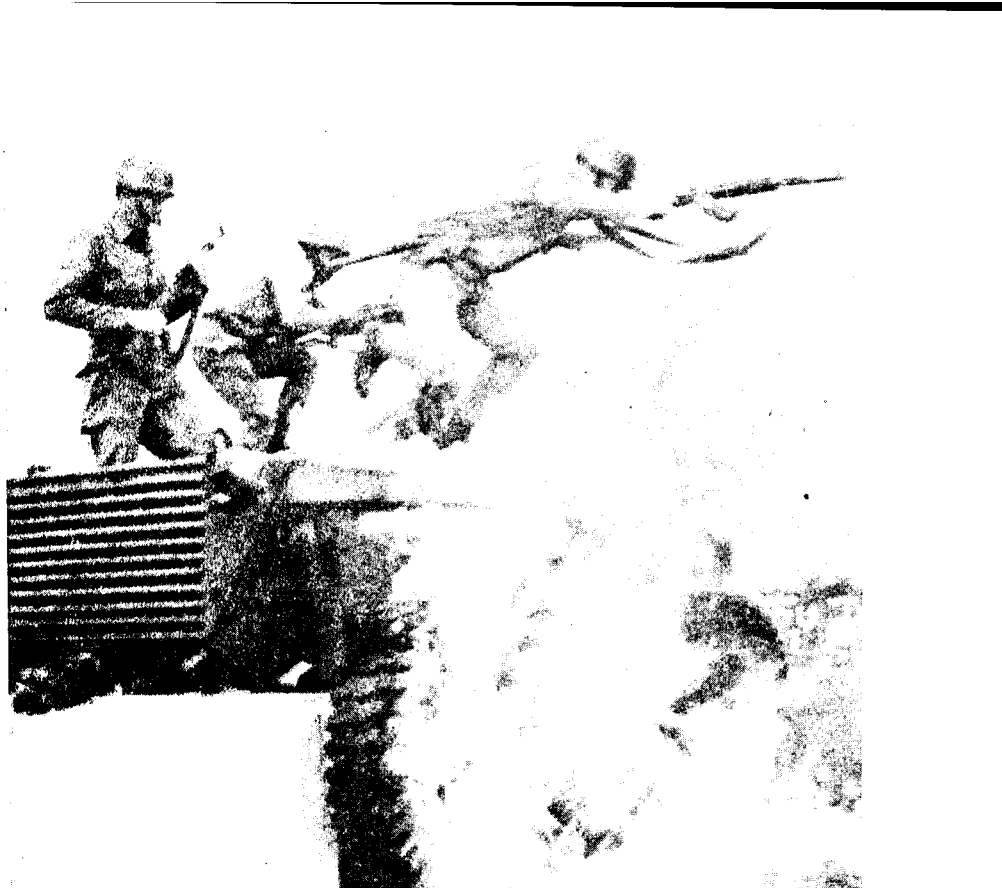

Training in an incendiary environment.



The Model LPO-50 Portable Flamethrower. Cubans have used napalm in exercises.

Most military training is conducted in-country, although every year hundreds of officers and enlisted personnel of all ranks are sent to the Soviet Union and occasionally to other selected Warsaw Pact countries for advanced training. Soviet military advisers are assigned to supervise military training in Cuba.

2. PRERECRUIT TRAINING

According to the 1973 Law of General Military Service, prerecruits are those males, aged 16 to 28, who have registered for the draft but who have not been called to active duty. They are obligated to receive military instruction.

The prerecruit program began in 1972 in the Havana area and has since spread throughout the country. The program is conducted under the direction of the Patriotic-Military Work Group, which is subordinate to the Patriotic Military Commission (figure 3), and in cooperation with civilian government agencies. The courses usually are 5 to 10 months long and are held two to three times a

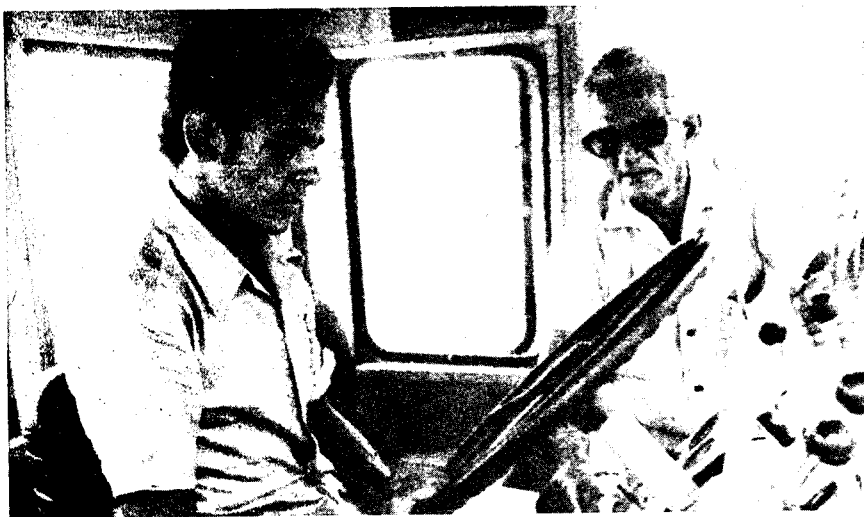

This student, who is learning to operate heavy construction equipment, is undergoing prerecruit training. Most of this training is conducted by civilian government agencies under the auspices of the Patriotic Military Work Group.

week during the evening in 2-hour sessions so as not to interfere with trainees' civilian employment. Mandatory subjects include political indoctrination and military discipline. Specialties taught include: radiotelegraphy, automotive mechanics, operation of heavy construction equipment, truck driving, first aid, firefighting, and logistical procedures. Most of the students report for active duty immediately upon termination of the courses, although some enter the reserves. The prerecruit program has trained thousands of young men between the ages of 17 and 20.

3. BASIC TRAINING

Recruits are inducted twice annually: July-August and January-February. After passing the physical exam, a recruit is sent to one of the camps which conduct training in individual specialties such as armor, artillery and engineers. The training lasts 45 to 60 days, depending upon the specialty. Although a recruit usually is sent to a camp of the army responsible for his area, some are sent farther away.

Basic training consists of a combination of classroom and field training and includes the following subjects: military courtesy, discipline, close order drill, sanitation, small arms firing, physical fitness, nuclear, biological and chemical (NBC) instruction, political indoctrination and small unit (squad and platoon)



Members of a sapper unit learn how to blow up a bridge.

tactics. Those assigned to specialties, such as armor, are also instructed in basic skills of that specialty. The average daily schedule begins at 0500 hours and ends at about 2200 hours. Training is rigorous and is conducted 6 days a week excluding Sunday. Recruits usually are restricted to the base on Sunday.

Upon completion of the basic training, the recruits take the oath of enlistment and begin their 3-year commitment. Personnel are then usually sent to their assigned units for further military training, although some are sent to schools for additional training, especially in technical subjects.

4. SPECIALIST TRAINING

Specialist training for enlisted personnel, including small-unit leaders, is conducted primarily at the division level, although each army also conducts such training. Advanced weapons training is sometimes accomplished through the use of simulators as well as with "hands on" instruction. Most courses are less than a year long.

5. OFFICER TRAINING

Cuba has established a system of military schools for several age groups. These schools are under the Directorate of Schools and Academies (figure 4) which has very close ties with the civilian education ministries. Within the last 4 years, MINFAR has raised the enrollment standards for all schools. Students are generally well trained, dedicated and heavily indoctrinated.

a. *Preuniversity Schools*

The Camilo Cienfuegos Military Vocational Schools (EVMCC), established in September 1966, are the only preuniversity (senior high school) institutions whose mission it is to train the future cadre of the Army, Navy and DAAFAR. Presently, there are at least nine schools located throughout the country with a total enrollment of 5,000 to 7,000 students. Two schools train students for the DAAFAR and two others instruct students for the MGR; the remainder teach



Running through an obstacle course. The military emphasizes physical conditioning.

students for the ground forces. Most of the students are boys, who are called "Camilitos;" the girl students are called "Camilitas." The schools have classes from the 10th through the 13th grades; students can be as old as 20 years of age when they graduate. Most of the students board at the school.

In order to qualify for these schools, students must be at least 16 and not more than 18 years old, be in good physical condition, and have a good scholastic and personal record. In addition to the regular academic courses such as English, Russian, mathematics and chemistry, there are military courses in tactics, small arms instruction, infantry training, topography, chemical defense and military engineering as well as some field exercises.

Students can graduate from the EVMCC in either the 12th or 13th grades (the 13th is equivalent to the last year in the Cuban senior high school). In addition to the officer schools described below, the graduates attend other technical schools and universities. The EVMCC, which first began graduating students in 1971, now accounts for over 75 percent of the students entering the officers schools.

b. *Officer Schools*

Presently, there are three schools which train officers for the Cuban Army: the Military Technical Institute, the Major Camilo Cienfuegos Revolutionary Armed Forces Artillery School, and the General Antonio Maceo Revolutionary Armed Forces Interservice School. General requirements include passing a physical examination and having a good academic record with no repetition of any grade. Candidates must be unmarried and of good character. The three schools offer a variety of courses and yearly field exercises; they award degrees which are recognized by the Ministry of Higher Education. Girls can attend only the Military Technical Institute.

(1) *Military Technical Institute*

The Military Technical Institute (ITM), founded in 1966, is located at Marianao, Havana City. As the principal technical training school for MINFAR, it has trained over 1,000 male and female technical officers for the Army and DAAFAR and possibly for the Navy. Presently, the school offers 5-year courses for mechanical engineers in field artillery, infantry armaments, tanks and transports, as well as 5-year courses for military and civilian construction engineers. Special requirements for applicants for these courses include graduation from a preuniversity and minimum-maximum age of 17 and 21, respectively.

ITM also offers two 4-year courses. One provides training for technical officers as electromechanical technicians in antiaircraft artillery weapons, mechanical technicians, in field artillery and infantry weapons, ammunition, tanks, transports, and fuels and lubricants. The other 4-year course trains construction technicians for military and civilian projects. Candidates for both 4-year courses must have a minimum of a 10th grade education and be at least 16 and not more than 21 years of age.

(2) Major Camilo Cienfuegos Revolutionary Armed Forces Artillery School

Located at the La Cabana Fortress which guards Havana Harbor, the Major Camilo Cienfuegos Revolutionary Armed Forces Artillery School was established in 1963. It is the principal source of all field and anti-aircraft artillery officers. It has a 5-year course for training military engineers in the fields of munitions, armaments and anti-aircraft electronic systems. Candidates must be graduates of a preuniversity, a technical institute or high school and be between the ages of 17 and 21.

The school also offers a 4-year course for training officers to command field, anti-aircraft artillery, reconnaissance and radiotechnical units. It offers courses to train political officers for field and anti-aircraft artillery units. Candidates must have completed a preuniversity and be between the ages of 17 and 21.

(3) General Antonio Maceo Revolutionary Armed Forces Interservice School

The General Antonio Maceo Revolutionary Armed Forces Interservice School, founded in February 1963, is located at Ceiba del Agua, 45 kilometers southeast of Havana City. It has 3- and 4-year courses for training tactical and technical command officers in the following troop specialties: mechanized infantry, tank, engineer, NBC and radio communications. The school also has a program for training political officers. Admission requirements include graduation from the 10th grade with a minimum age of 15 and maximum age of 21.

c. Advanced Officer School

The General Maximo Gomez Revolutionary Armed Forces Academy, established in July 1963, moved to a new location in western Havana Province in early December 1976. It is MINFAR's senior military school and is approximately equivalent to the US military middle and senior-level service schools. It is responsible for training middle and upper-level officers from the Army, DAAFAR, MININT's Special Troops and the Navy. The Academy also provides an extension course program which is open to qualified active officers who are under the age of 40.

d. Other Officer Training

Junior officer training programs, particularly for leadership positions, are conducted at the army level, where there are training regiments. Selected courses are also offered at division level. Each officer school also provides advanced training in the subjects of its specialties.

6. YEARLY TRAINING CYCLE

The Chief of the Combat Training Directorate (figure 3) is responsible for all matters concerning tactics, doctrine and weapons training. The Chief of the Central Political Directorate (figure 3) is responsible for the political indoctrination which is an integral part of the training programs.



Practicing with 120-mm mortars.



Regular and reserve Army units participate in an interservice exercise. The vehicle on the right is a BTR-152 Armored Personnel Carrier.

The yearly training cycle is composed of two 6-month periods: September-February and March-August. The training programs are called "Basic Study Materials" (BME). Initially, training focuses primarily on classroom instruction for the enlistees. Texts used in the classes are principally of Soviet origin, translated into Spanish. Instructional techniques stress repetition. After mastering the basics, the personnel participate in progressively larger exercises from squad to battalion level. Regimental and/or divisional exercises involving several thousand personnel, including reservists, may be conducted two or three times each year. These exercises usually involve Navy and DAAFAR units. The theme of regimental exercises is the repelling of a large-scale enemy (US) landing, and may cover night maneuvers and nuclear, biological and chemical (NBC) scenarios.

Training during the second cycle is more varied: those units which have large numbers of newly inducted personnel focus on learning basic skills while the other units review previous material and conduct additional exercises. A major multiservice exercise, involving as many as 12,000 regular and reserve personnel, is usually held near the end of the calendar year. Other military units, such as those assigned to the Rear Services Headquarters, also conduct exercises in December and early January.

To encourage maximum performance throughout the training year, all personnel and units are urged to compete for "Socialist Emulation" and "Vanguard" awards (illustrated in chapter 6), both of which are presented to outstanding individuals and units at all level. The national winners are brought to Havana where they are honored by the national leaders for their accomplishments.

7. FOREIGN MILITARY TRAINING

Almost all of foreign military training takes place in the Soviet Union, and includes instruction in elementary, specialized, tactical and doctrinal subjects. Those who attend must be able to speak, read and write Russian. Students sent to the Soviet Union include those who just graduated from the Camilo Cienfuegos Military Vocational Schools, or the officer schools, as well as enlisted personnel. The length of the courses varies from several months to 4 years.

Section E--Logistics

1. GENERAL

Since 1970, MINFAR has made major improvements in all aspects of its logistics and maintenance. The government has integrated the civilian and military logistical structures at every level and has stockpiled war materiel throughout the island.

Cuba has no major geographical obstacles to hinder the flow of logistics on its principal landmass. The dominant method of transportation is by surface means. Cuba has generally good surface transportation facilities and networks, especially in the major populated areas. Most of the transportation networks, particularly

the rail, run east-west. Cuba has been expanding its surface transportation system by upgrading its highways and by constructing a high speed railroad from Havana to Santiago de Cuba. The Merchant Marine fleet consists of 72 ships of at least 1,000 gross registered tons totaling approximately 700,000 deadweight tons (dwt) and is capable of providing considerable support, but port congestion prevents quick responses. The fishing fleet, which has about 230 vessels with a total of 168,000 dwt, and especially the refrigerated ships, can supplement the merchant fleet. The country has limited civil and military air transport capabilities (discussed in chapter 4).

Cuba is almost totally dependent on the Warsaw Pact, particularly the Soviet Union, for war materiel, although the Cubans produce some ammunition and explosives. The Cubans can maintain and repair the equipment, but Soviet advisers and technicians render important support on the more sophisticated equipment. Equipment is maintained in effective combat condition. There is a strict system of control over spare parts and there are usually adequate quantities of parts to meet maintenance needs.

Cuba has a small oil-producing capability; the majority of its POL requirements, however, are satisfied by the USSR. Cuba also imports a large share of its basic foodstuffs, such as wheat, corn and its staples of rice and beans.

2. LOGISTICS PRINCIPLES

Cuban logistical principles are modeled after those of the USSR and include:

- *Centralization of planning.* MINFAR executes its logistical requirements in conjunction with appropriate state ministries. The government also provides for coordinated use of logistics facilities, transport, supply bases and medical installations in support of various armed forces components.
- *Command Control.* Within each echelon, logistics is regarded as a function of command.
- *Tailoring rear services to combat operations.* In spite of the high degree of centralization of logistics operations, rear services commanders have enough flexibility and opportunity for initiative to permit them to adjust logistical support as combat conditions and technical demands vary.
- *Priority of combat supplies.* The order of priority is normally: ammunition, POL, supplies and rations.
- *Use of all possible resources.* Exploitation of local resources can be expected. Both friendly and captured materiel is subject to intensive salvage.
- *Forward distribution.* The higher unit is generally responsible for the allocation and delivery of supplies to the lower units.
- *Accountability.* Supply discipline is strict and effective. Personal accountability for equipment and supplies is rigidly enforced to keep waste and loss at a minimum.

3. ORGANIZATION FOR LOGISTICS AND MAINTENANCE

At the national level, the Rear Services Headquarters (figure 3) is responsible for supply and service functions common to military elements and personnel. Included are functions pertaining to food, clothing, personal equipment, POL, medical and veterinary services, post exchanges, transportation, research and development, procurement, storage, issue and maintenance of common-use items. The General Staff's Directorate of Military Commerce (figure 4) is responsible for distributing some industrial and food products and providing recreational and other services.

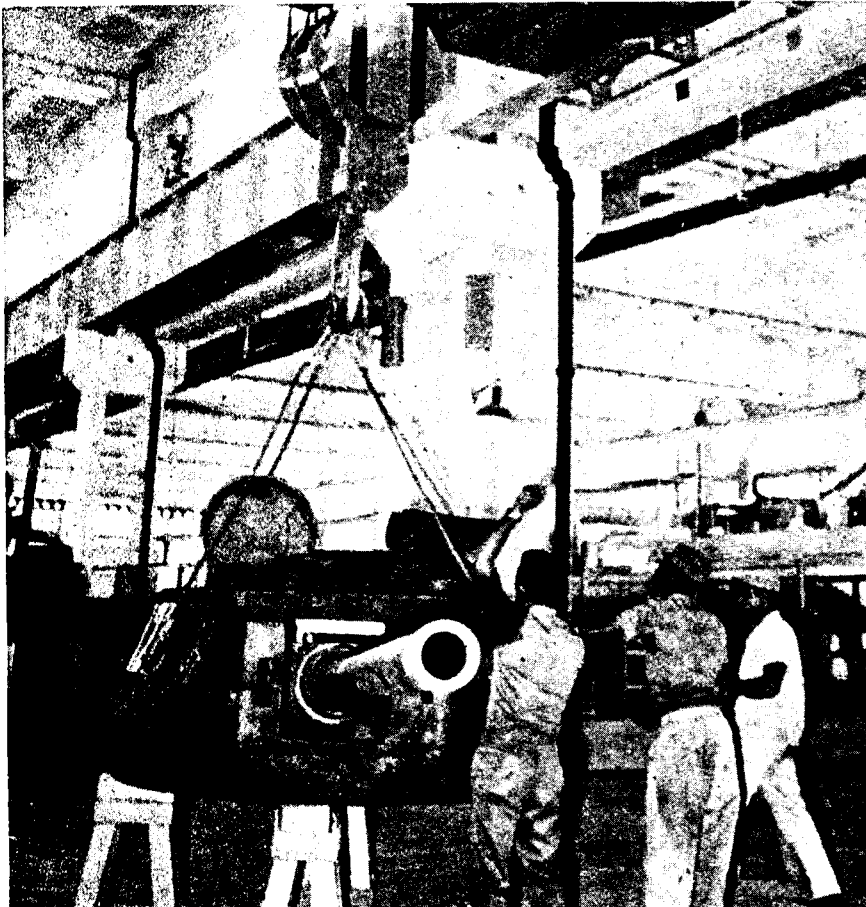

Moving a T-34 tank turret. MINFAR has the capability to accomplish major overhaul and repair on most of its equipment.

The General Staff's Engineer, Chemical Defense, Artillery and Tanks and Transports Directorates (figure 4) probably are responsible for requisitioning and supplying items within their technical fields. For example, the Directorate for Tanks and Transports probably is responsible for all armored vehicles and trucks. The Directorate for Artillery probably has the additional responsibility for requisitioning and supplying all types of ammunition.

Information on the present national organization for major repair facilities is not available, although they probably are under the staff supervision of the General Staff's Industrial Enterprises Directorate (figure 4). Major repair and overhaul of equipment, and probably the manufacture of the more simple components of weapons systems, are carried out by the several general repair depots, most of which are called "FAR Military Industrial Enterprises." The major enterprises include those that handle tanks, artillery, transportation, ammunition and communications.

The organization, procedures and allocation of Cuban maintenance, repair and recovery assets are based on the Soviet system. Supply and service units are divided at the higher echelons and combined at the lower. At the army, corps and division levels and at the artillery, mechanized infantry and armor regiment levels, there are separate units for each. At the battalion level, the supply and maintenance services are combined in one platoon. The individuals who handle rear services are responsible to their tactical commanders, and receive staff supervision from the next higher supply and maintenance units. In joint operations, the chiefs of the rear services and maintenance units at the army and corps levels probably are responsible for coordinating the common rear services and maintenance needs of other forces, such as the Navy and DAAFAR.

4. PROCEDURES FOR DISTRIBUTION OF REAR SERVICES ITEMS

a. General

Within the last 2 years, MINFAR has been a leader in Cuba in modernizing cargo-handling procedures and has learned much from its involvement in Africa. The improvements, which have allowed MINFAR to handle more goods with less personnel, have included constructing better storage facilities, streamlining methods and procedures for the handling of bulk materials, and mechanizing the handling of materials in warehouses. During a mobilization, MINFAR can take over all transportation facilities and networks, integrating them to meet its needs. This procedure is simplified by the fact that MINFAR has many reservists who work in the civilian transportation field. Also, mobilization exercises frequently involve the use of civilian facilities.

Generally, MINFAR employs forward distribution principles. Supplies move from factories, warehouses or arsenals directly to army or corps depots via railway or motorized transport. From the army or corps depots, supplies reach division supply points by transportation organic to either the army or the corps. Supplies then are normally distributed to regiments from division supply points by division transportation. Occasionally, supplies are sent directly to regimental dumps or to the consuming unit to avoid unnecessary handling. Regimental supply points are probably little more than distributing points where incoming supplies are broken down for further distribution.



A reserve railroad unit repairs some railroad tracks. The unit is subordinate to MINFAR's Rear Services Headquarters.

Information concerning average daily resupply requirements for Cuban units in combat or peacetime environments is not available.

MINFAR has constructed many storage facilities throughout the country. These storage facilities range from open areas for such items as trucks to underground storage facilities for ammunition and small arms.

b. *Petroleum, Oil and Lubricants (POL)*

The responsibility for POL in the MINFAR begins at the highest military echelon with the MINFAR Chief of the Rear Services, who is normally a deputy minister. Cuba probably follows the Soviet model with modifications based on the comparatively smaller number of armored and transportation vehicles in most units. Regular infantry divisions probably are responsible for the principal storage and delivery of POL to their subordinate units, and the mechanized infantry and tank regiments each have a POL platoon that delivers POL to the subordinate battalions for distribution. Combat vehicles are refilled as close to the combat as the situation will allow.

The Cubans probably follow the Soviet method of computing fuel stock-age requirements, which is the "refill." For wheeled vehicles (thin-skinned, such as trucks) it is the amount of fuel necessary for a 500-kilometer range at normal rates of consumption. For combat vehicles, the "refill" is the amount of fuel carried in the integral fuel tanks. A unit's fuel allocation is made in numbers of "refills" rather than in liters of fuel. The amount of "refills" issued is determined by the mission and is specified in the plans. Lubricating products are issued in percentages of the "refill."

c. Medical

The Directorate of Medical Services is headed by a colonel who is subordinate to the MINFAR Chief of the Rear Services. He has supervisory responsibilities over all military medical, dental and veterinarian matters. Each army directly controls at least one permanent medical hospital facility which primarily treats long-term or complicated cases from all services and also conducts research. Patients are principally members of the regular armed forces, although certain categories of civilians such as members of families of high ranking officers and some other civilians are probably also treated. The hospitals are staffed by civilian and military doctors, nurses and technicians.

Regular Cuban military personnel receive good medical care, probably better than the average civilian. Immunizations are given to all personnel prior to overseas duty. All doctors have a service obligation. Those who serve their compulsory service in some other government agency are then incorporated into the reserve system. In an emergency, MINFAR's existing military medical facilities would be supplemented by the extensive and expanding civilian medical facilities.

The Cubans probably follow the Soviet model, treatment by stages, in rendering medical support to troops during combat. This provides for the timely administration of emergency medical aid in conjunction with continuous classification (sorting) and evacuation of wounded to the rear by successive stages.

Therapy begins on the battlefield where emergency first aid is administered either by the casualty himself, his fellow combatants, or the company aidmen. The wounded are then evacuated to either the company or battalion medical point. Ambulatory wounded are expected to make their own way to the battalion station. Some medical treatment is rendered at the battalion aid station, which is manned by personnel from the regimental medical unit. After being sorted, the wounded are evacuated to the regimental medical station where the patients first come in contact with a doctor. After further sorting, the wounded are then evacuated to the division mobile field hospital or to a more permanent medical facility.

The mobile field hospital may have a capacity of up to 250 beds dispersed among several wards. Although some major surgery can be performed in the field hospital, most surgery is conducted in the permanent medical facilities.

On 15 April 1954, Cuba ratified the 1949 Geneva Convention concerning the treatment of the wounded and sick of all armed forces in the field.

d. Rations and Water

The Deputy Minister, Chief of the Rear Services, is responsible for providing rations. In both garrison and wartime conditions, the units probably procure most of their food (usually through purchase) and water from local sources. Field rations, which are produced in the USSR, are also available.



Administering oxygen to a "wounded" soldier.



Extinguishing a fire on a soldier.

Meals are served three times a day. The meals are simple, consisting of such staples as rice and beans with small portions of meat. The military diet is generally larger and more nutritious than civilian fare.

The Cuban military possesses the equipment necessary to supply potable water in the field. Water purification is probably the responsibility of the engineers; purification is verified by the medical section. Troops also use water purification tablets.

5. MAINTENANCE, REPAIR AND RECOVERY

Permanent maintenance facilities are located in each army, corps, division and regiment area in Cuba. Facilities at battalion level are supplemented by regimental mobile repair facilities.

There are strict maintenance schedules for all systems based on either hours or mileage. The maintenance schedules must be met or the equipment is dead-lined until the required maintenance is performed. Each crew is responsible for accomplishing "preventive maintenance" both before and after the equipment is used. The crews have specific responsibilities such as maintaining oil and water levels and keeping the equipment clean. The commander of the unit and the chief mechanic both sign the equipment's maintenance checklist and approve any requisition of parts.

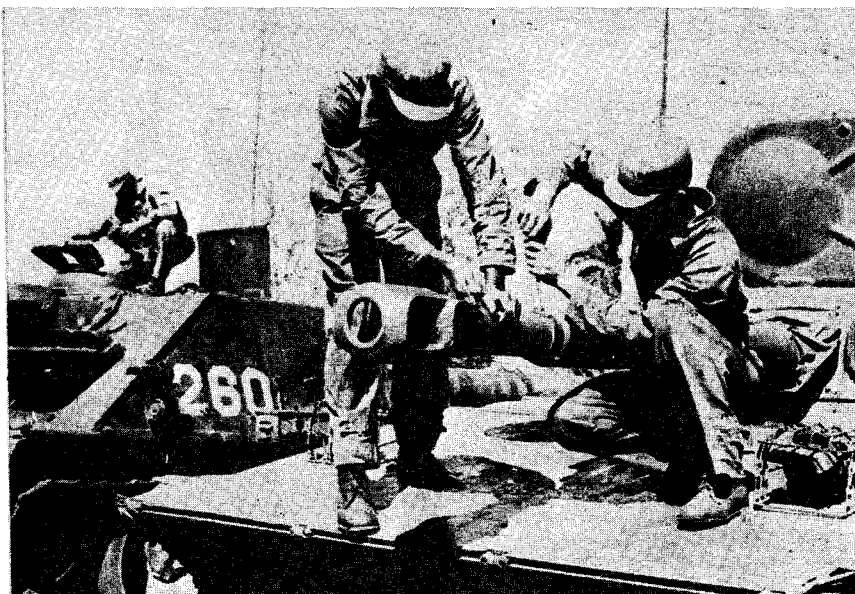

Performing operator maintenance on a PT-76 Light Amphibious Tank. The vehicle in the background is an SU-100 Assault Gun.



Repairing treads on a T-55 tank.

Generally, the extent of repairs is determined by the capabilities of the facilities at any particular level. Usually, repairs are accomplished at the lowest possible level.

Battlefield recovery of both friendly and enemy equipment is stressed; however, information on recovery procedures is not available.

6. SUPPLY PROCEDURES FOR AMMUNITION

Army, corps, division and regiment rear services components maintain ammunition supply dumps. Ammunition stocks to be maintained at each echelon are specified by higher headquarters. Resupply from army or corps to division, from division to regiment, and from regiment to battalion is normally accomplished by organic motorized transport. During combat, resupply of ammunition is facilitated by the establishment of temporary ammunition dumps and frequent shifting of supply points. The stockpiling of ammunition in forward areas is a common practice. In addition, the Cubans have built underground ammunition depots throughout the island.

Cuban higher headquarters most likely follow Soviet procedures and prescribe ammunition stocks on the basis of standard allocations per type of weapon, that is, by the "unit of fire"—the amount of ammunition predetermined as optimal for each individual weapon in the tables of equipment. Normally, the "unit of fire" is based on the practicality of the ammunition accompanying the weapons (the number of rounds it is possible to carry in a tank, with a rifleman, etc.).

The "unit of fire" *does not* exactly equate to the US Armed Forces "basic load," and it is *not necessarily* the amount of ammunition that a given unit will carry for each weapon. The Cubans rarely speak of number of rounds concerning ammunition requirements. The use of "units of fire" also provides additional protection against enemy combat intelligence activity. The number of rounds in a given "unit of fire" is closely held information.

Another factor in determining the "unit of fire" allocations is the mission requirements. For example, if a 152-mm howitzer battery has a "unit of fire" of 360 rounds, then these 360 rounds will normally accompany the unit; however, to support a mechanized infantry regiment on the offensive, the battery commander might receive 1.5 "units of fire." "Unit of fire" allocations may be broken down into specific fire missions. For example, the fire plan of the 152-mm artillery battery in support of a mechanized infantry battalion defending an assigned coastal sector against an enemy amphibious assault force might specify the expenditure rates for an allocated 2.0 units of fire: destruction of reconnaissance of craft and minesweepers—0.2 units of fire; destruction of assault craft approaching the shore—0.7 units of fire; destruction of naval transports at anchorage site—0.3 units of fire; and neutralization of amphibious force upon hitting the beach—0.8 units of fire.

7. PRISONERS OF WAR (POWs)

Information concerning Cuban procedures for handling prisoners of war is not available. Cuba did ratify the 1949 Geneva Convention concerning the treatment and repatriation of POWs, on 15 April 1954. Captured persons are undoubtedly interrogated by military intelligence personnel and then by the Department of State Security (DSE).

Section F—The Army Reserves

1. GENERAL

Cuban reserves consist of a first and a second reserve. The first reserve includes politically reliable personnel who have received active military training. Although male personnel up to the age of 50 (women up to the age of 40) may be retained in the first reserve, those under 35 receive considerably more training and are the first to be mobilized. The second reserve is composed of other personnel, including those considered politically unreliable and criminals. Although these people have military training obligations, they receive less training than those in the first reserve.

The ready reservists are part of the first reserve. They are thoroughly integrated into the Army and account for about 30 percent of the combat-ready force. Since over one-half of the Cuban troops deployed to Angola and Ethiopia were ready reservists, thousands have now had actual combat experience.

The majority of the ready reservists are assigned to units. They are assigned to all positions except possibly some mid-level and most high-level command positions. Ready reservists are trained in most of the same skills as regular personnel. Women reservists are assigned to combat service and combat service support units in specialties such as communications and nursing.

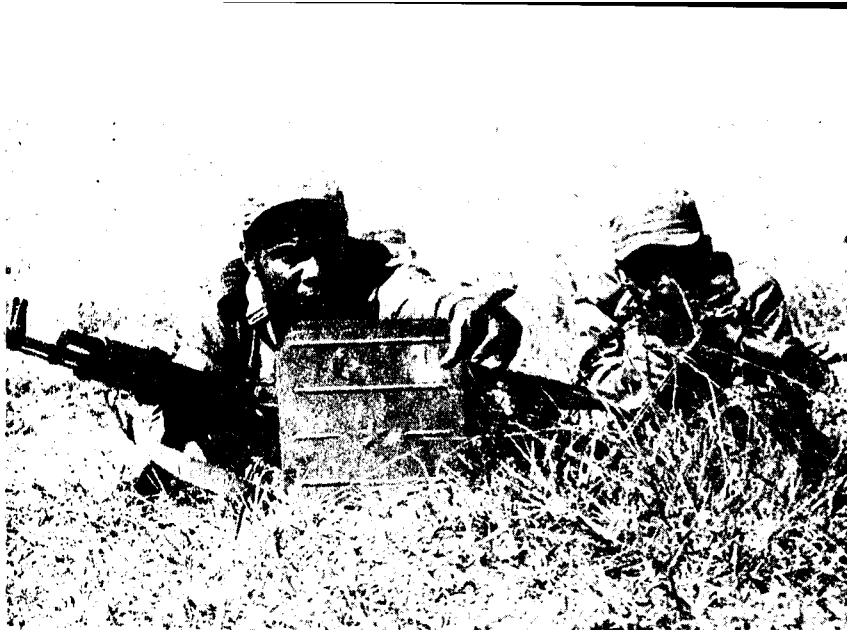

Two reserve infantrymen. The one on the right has a light machinegun. Thousands of reservists have received combat experience in Africa.



A reserve unit practices defending against an enemy landing.

Training for ready reservists and some other selected first reservists may include one 2-hour period each week, and one Sunday each month. Almost all ready reservists and other selected first reservists have about 45 days' extended active duty a year. Reservists can be mobilized for as long as necessary. Reservists are compensated only for long mobilization or training periods, such as the 45 days' annual training. The salary is the responsibility of the civilian government agency for which the reservist works; MINFAR pays only those few who are privately employed. Reservists are guaranteed reemployment rights upon completion of mobilization.

While on military duty, reservists are subject to military discipline and authority. However, should a reservist be injured while training and be partially or totally disabled, benefit payments would be derived from his civilian social security fund. Duty as a reservist does not count towards retirement in the active military.

Reserve officers and noncommissioned officers are distinguished from regular army personnel only by the word "reserve" which is part of their rank in both written and oral communications. Currently, the highest reserve officer rank known to exist is that of colonel. Reserve personnel in positions of command responsibility have authority over lower ranking regular Army personnel. Reservists usually are promoted on Militia Day (16 April).

2. RESERVE ORGANIZATION AND MOBILIZATION

a. *Organization*

The Directorate of Organization and Mobilization (figure 4), is the MINFAR General Staff element responsible for managing the reserve system. Local mobilization sections maintain detailed records on all reservists and are responsible for assigning reservists according to the needs of the military units. The sections are also responsible for assuring that reservists who are not assigned to units accomplish their training obligations.

In military units, there are three principal categories of manning levels (discussed in chapter 2, section A-5). In categories II and III, the principal function of the active duty personnel assigned to the units is to form the cadre and to maintain the unit's equipment. When these units are mobilized for combat or for training, the active duty personnel assume the principal leadership and technical positions while the reservists are assigned as fillers. Reservists can also be mobilized to fill specific vacancies in regular or reserve units.

b. *Mobilization*

All Cuban ministries and other government-owned facilities, such as factories, must identify and maintain, at their own expense, some of their assets and equipment for use by MINFAR in the event of mobilization or a national emergency.

The Cubans have developed a very extensive and effective call-up system which mobilizes ready reserve personnel within 2 to 4 hours at the local level. The mobilization system is used for calling up personnel for specific long-term assignments, such as to Angola and Ethiopia; for regular training exercises;

or to test the response time. Warnings of mobilization exercises are very rarely given. The mobilization system is so refined that thousands of reservists can be called up nationwide without seriously disrupting any one city or town.

Local Military Committees are responsible for notifying civilian employers that their employees have been mobilized. The civilian chief can appeal to the Military Committee for an exemption of a specific individual, but such appeals usually are unsuccessful. Approximately 80 percent of those summoned respond in a timely manner. Generally, the most common excuse for not responding is sickness. Those who chronically avoid mobilization are subject to punishment.

The Cubans have plans for mass mobilization in the case of grave national emergency. Under these circumstances, all available personnel in the first and second reserves—numbering several hundred thousand—as well as the MINFAR paramilitary and MININT forces would be mobilized.

The process of notifying a unit, for example, a reserve division, in an emergency situation involves close cooperation between the military units and the mobilization sections. The military units are responsible for notifying the people assigned to their units. The mobilization sections are responsible for notifying those not assigned to a unit on a permanent basis and for coordinating those civilian agencies that provide equipment such as additional trucks, to the units.

3. TRAINING

a. *General*

Reserve training, like that of the regular Army, has been considerably upgraded since 1970. It is similar to that of the regular Army, except that the training usually is less extensive. Reserve units do have to meet training goals. A few reservists may have weekly evening sessions, which usually are devoted to classroom instruction and activities such as close order drill. Some also may have monthly Sunday sessions, which may take place at a nearby military camp, and includes the handling of small arms and other weapons. Almost all reservists have 45 days' annual training, which takes place at a major military installation, and usually includes field exercises and weapons firing.

b. *Reserve Officer and NCO Schools*

There is some school training for reserve officers and NCOs. There are at least two schools, one in the Western Army and the other in the Eastern Army, that train small unit leaders. Additionally, the General Antonio Maceo Inter-service School and the Military Technical Institute also train reservists. Some reservists, political officers, for example, have received training in the Soviet Union.

c. *Senior High School and University Reserve Officer Training*

Beginning in late 1975, MINFAR introduced compulsory reserve officer training courses at selected senior high schools and universities. The program is directed by MINFAR's Patriotic Military Work Group, which is subordinate to



University of Havana students receive instruction in firing rifles as part of MINFAR's training program at selected senior high schools and universities for potential reserve officers. Even those studying medicine must undergo reserve training.

the Patriotic Military Commission (figure 3). The program, which has trained over 10,000 personnel by mid-1978, has regularly scheduled classroom and field training; subjects include weapons firing, tactics and first aid as well as military discipline. Upon graduation from the senior high school or the university, the graduates are commissioned as reserve officers in the Army and DAAFAR. Most DAAFAR reserve officers are trained in air defense artillery.

Section G—MINFAR Paramilitary and MININT Forces

1. MINFAR PARAMILITARY UNITS

MINFAR refers to two groups of forces in "paramilitary" units: the Youth Labor Army (EJT) and most major combat service support organizations at and above corps level. In case of national emergency, both groups would be mobilized.

a. *Youth Labor Army (EJT)*

(1) *General*

The Youth Labor Army (EJT) is, by law, a paramilitary organization under the direct control of MINFAR. It was formally established on 3 August 1973 by combining two similar organizations: the Centennial Youth Column (CJC) and the Permanent Infantry Divisions (DIP). The consolidation enabled the Cuban Government to eliminate existing duplication and manage the large labor force more efficiently.



Two EJT members collect sugarcane which was cut by machete. Most work for the sugar industry.

(2) *Missions and Capabilities*

The EJT has three missions. The first, and most important, is to contribute to the country's economic development. This is accomplished by having EJT members work in the sugar industry, on the railroads, and in the construction industries. The EJT is accomplishing its assigned economic missions. Its personnel harvest about one-quarter of the sugarcane that is cut by hand.

The EJT's second mission is the indoctrination and education of all its personnel. All EJT members receive indoctrination and are expected to have at least a sixth-grade education upon completion of their EJT service.

The third mission of the EJT is to assist with territorial defense. In wartime, the EJT would supplement the regular and reserve ground forces. However, EJT members have received only training in elementary infantry subjects, and do not participate in military exercises with the regular and reserve forces. Therefore, their potential effectiveness is questionable.

(3) *Strength*

The EJT has approximately 100,000 men and women.

(4) *Command and Control, Organization and Deployment*

The EJT is headed by a MINFAR Deputy Minister who reports directly to the First Deputy Minister and Chief of the General Staff (figure 3). The EJT National Headquarters consists of the MINFAR Deputy Minister, the

Deputy Minister, the Chief of Staff, and the chiefs of several functional directorates and units. The directorates and units in the National Headquarters include: Political, Personnel, Operations (and Training), Instruction (charged with literacy education), Sports, Rear Services, and Construction.

The EJT National Headquarters directs regional headquarters, of which there are at least six. The regional headquarters structure is similar to that of the National Headquarters. Units subordinate to the regional headquarters are organized along military lines; however, units do vary greatly in organization and strength and should not be compared to regular and reserve Army units of the same designations. Most EJT units are stationed in the eastern half of Cuba.

(5) Identification

EJT units use 5-digit Military Unit Numbers (MUN). Some battalion-size units also are identified either by a one-digit ordinal number (example: First Battalion) or by a location (example: the "Jaitibonico Battalion") or both. Units above battalion are also frequently identified by location. The sugarcane-cutting "brigades" (platoons) are named in honor of a Cuban or foreign martyr or after an historic Cuban event (example: the "Victoria de Giron Brigade," commemorating the Bay of Pigs victory in April 1961).

(6) Composition and Ranks

The EJT is composed primarily of personnel inducted under the compulsory service laws. There are also a number of volunteers who are mostly women. Some of the cadre are members of the regular Army. Most of the inductees are less qualified, particularly educationally, than those who enter the regular armed forces. Some of them are required to serve in the EJT because of their "antisocial behavior."

The EJT rank system, modeled after the regular Army, ranges from "EJT private" to "EJT colonel." The EJT, like the regular Army, also has technical ranks. Regular Army officers who are occasionally assigned to the EJT retain their regular rank. The EJT's work uniform is a beige shirt with green pants.

EJT members receive a salary commensurate with the quality and quantity of work performed and comparable to civilian pay scales. They also receive a 1-month vacation each year. Most live in barracks in military camps where they are fed and clothed.

(7) Training and Equipment

The EJT is responsible for its own training. The recruits receive 1 month of military training upon induction and periodic refresher courses thereafter. The training is limited to indoctrination, physical training, military discipline, some small arms instruction and small unit (squad and platoon) tactics.

There are several schools to train cadre as basic education instructors and to teach skills required to work in construction or on the railroads.

EJT members also attend specialized schools run by other ministries to learn additional technical subjects.

The EJT has small arms. They may have some crew-served weapons such as mortars.

(8) *Separation*

Upon completion of service in the EJT, members are required to register for the reserves. Their elementary military training serves as a basis for the more advanced training they receive in the reserves. Those members who are trained in technical skills are expected to continue using them in civilian life.

b. *Major Combat Service Support Units*

Since 1975, MINFAR has designated as "paramilitary" many of the major combat service support organizations above corp level including Navy and DAAFAR elements. These organizations, whose total strength is not known, are supervised by the Rear Services Headquarters (figure 3), by the General Staff's Directorates of Military Commerce and Industrial Enterprises (figure 4) or by a military construction (not combat engineer) unit (figure 4). All of these units employ a significant number of civilians; they are all under military jurisdiction and most of them belong to the National Union of FAR Civilian Workers (SNTC-FAR).

Most, if not all, of these units have Military Unit Numbers in the 9,000 series. Identified paramilitary units include a clothing tailor shop, several military enterprises, general repair depots, construction units and a cement factory. Most military personnel assigned to these units have received formal technical training and most of the officers hold technical ranks.

2. MININT MILITARY FORCES

At least two units of the Ministry of the Interior (MININT) are "military" forces: the Special Troops and the Border Guard Troops (TGF). The organization, weapons, combat training and deployment of these two units are under MINFAR's jurisdiction. MININT's national headquarters is located in Havana. The headquarters is composed of several functional levels grouped under probably four deputy ministers. MININT provincial chiefs command most MININT organizations and personnel in their respective provinces. Most MININT personnel have military ranks.

a. *Special Troops*

(1) *General*

The Special Troops were established during the mid-1960s as a commando-type unit. The Special Troops wear the same camouflage fatigues (illustrated in chapter 6) as MINFAR's paratroopers (Assault and Landing Troops).



MININT's Special Troops were first publicly paraded on 6 June 1976, the 15th anniversary of MININT. They were among the first troops sent to Angola.

(2) *Missions and Capabilities*

The Special Troops serve as a highly mobile shock force available to provide protection to high ranking officials, to support other internal security requirements, and to provide training to selected foreign countries and groups. Some Special Troops have been deployed to Africa. The Special Troops are considered capable of accomplishing their assigned missions.

(3) *Strength*

The Special Troops have an estimated strength of 800 to 1,000.

(4) *Command, Control and Organization*

President Fidel Castro probably directly controls the Special Troops which are assigned to the Minister of Interior.

Headed by a MININT Colonel, the Special Troops are believed to be organized along the lines of an infantry battalion minus some service and combat support-related elements. Probably two battalions comprise the Special Troops.

(5) *Composition*

Personnel in the Special Troops are highly motivated, well educated and thoroughly indoctrinated. They probably are selected from both MINFAR and other MININT units.

(6) *Training and Equipment*

All members are parachute-qualified and at least some are SCUBA-qualified. All are well trained in hand-to-hand combat.

The Special Troops are equipped with small arms such as rifles, pistols and machineguns, as well as 82-mm mortars and light artillery pieces.

b. *Border Guard Troops (TGF)*

(1) *General*

The Cuban coastal protection force was established within MININT on 5 March 1963. It was first called the Coastal and Port Vigilance Department, then the Fight Against the Pirates, and later the Border Guard Force. In March 1975, as part of MININT's reorganization, it was given its present name, the Border Guard Troops (TGF).

(2) *Missions and Capabilities*

The TGF personnel guard the Cuban coastline on foot and motorcycle and in boat patrols. The missions of the TGF are to detect, identify and intercept any illegal infiltration or exfiltration and to repel raids. It is also responsible for monitoring port and fishing activities, patrolling navigation routes, checking crew lists, and monitoring water sports activities to prevent accidents.

With the assistance of Navy and DAAFAR radar support, the TGF is capable of maintaining coastal surveillance. It is also capable of repelling small-scale raids.

(3) *Strength*

The TGF has an estimated strength of 3,000 full-time personnel. It is augmented by two civilian auxiliaries, the Sea Watchers Detachment and the Border Militia. Their strengths are not known.

(4) *Command, Control and Organization*

Normally under the control of MININT, the TGF may come under the operational control of the Navy in time of crisis.

A MININT Colonel heads the Directorate General of the Border Guard Troops (figure 8). Subordinate to the Directorate are three districts—Western, Central and Eastern—which probably coincide with the boundaries of the three armies. The districts probably are further divided into eight territories. The boundaries of four of the eight TGF territories—Pinar del Rio, Las Villas, Camaguey and Holguin—probably are identical to those of the four army corps of the same names; one territory is the Isle of Youth. The remaining three boundaries probably are as follows: Havana Territory—Havana City Province and Havana Province; Matanzas Territory—Matanzas Province; Oriente Territory—Granma, Santiago de Cuba, and Guantanamo Provinces.



A member of MININT's Border Guard Troops (TGF) on patrol. The TGF patrols the shorelines to prevent illegal entry and exit. The man in the background probably is a civilian auxiliary. The TGF also uses dogs and small motorboats.

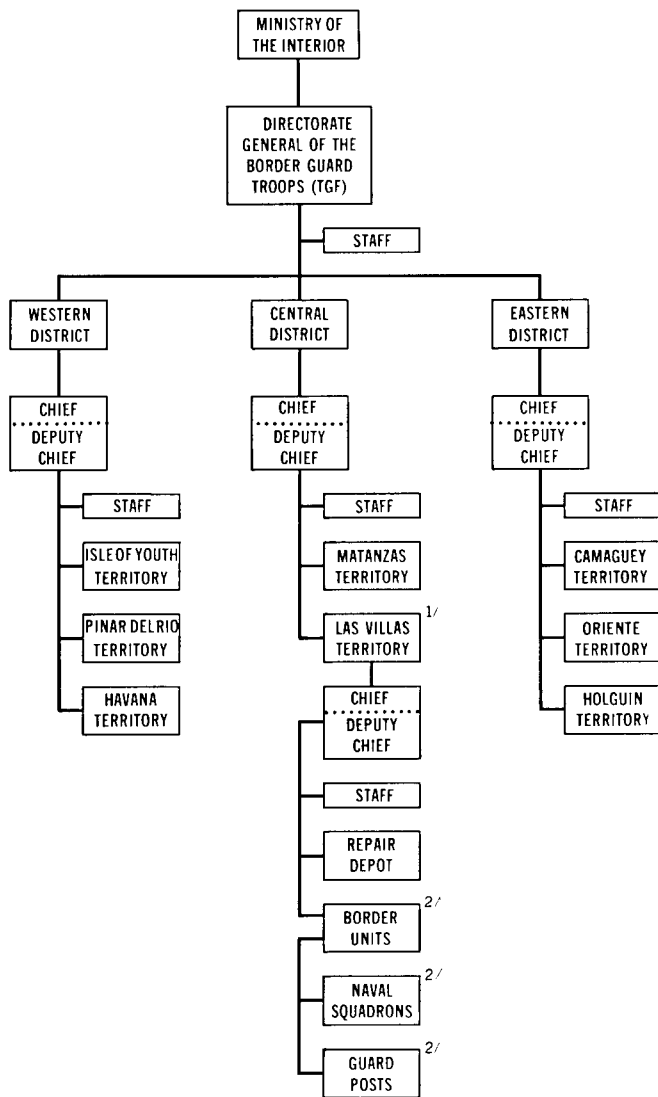

1/ Other territory organizations are probably similar to that of Las Villas.
 2/ Number and size vary.

Figure 8. Probable Organization of the Border Guard Troops (TGF)

Subordinate to each territory are a repair depot and varying numbers of border units further divided into several naval squadrons and guard posts.

(5) *Identification*

Some units, probably the major units directly subordinate to the territorial headquarters, have three-digit numbers (example: Unit 103, located at Esperanzas Port in Pinar del Rio Province). A TGF naval squadron may have a three-digit number (example: Squadron 040). Information on other means of identification is not available.

(6) *Composition and Ranks*

The TGF is composed of a cadre (officers and NCOs) of MININT personnel and draftees, supplemented by two civilian auxiliaries. The regular TGF personnel have military ranks while those serving their compulsory military service and the civilian auxiliaries do not. The TGF has its own uniform (illustrated in chapter 6).

Two civilian auxiliary groups, the Border Militia and the Sea Watcher Detachments, augment the TGF. Although neither is well armed nor well trained, both perform their primary mission, that of serving as the eyes and ears of the units they support. Information on the total strength of the two units is not available. Both have men and women, some over 50 years of age. Both organizations conduct joint patrols under the leadership of the regular TGF cadre. Their training includes rifle instruction and tactics of border patrols, both on land and in the sea.

(7) *Training and Equipment*

Personnel receive training necessary to accomplish their missions. Beginning in 1975, the military training was increased for all personnel. The Olo Panteja Border Guard School, established in 1970, trains chiefs of posts, deputy chiefs and port captains in such subjects as engineering, communications, harbor mastership, law, criminology and border guard tactics. Some personnel have been trained at Mariel Naval Academy; some have been sent to the Soviet Union to learn modern naval techniques and how to use and maintain equipment. MININT has a canine school which trains TGF personnel in dog handling.

The TGF forces conduct joint training exercises with DAAFAR and Navy coastal radar units. The TGF also cooperates with DAAFAR pilots and naval units in capturing Cubans who attempt to escape by boat.

The TGF is equipped primarily with rifles and pistols. It also has metal detectors, motorcycles, jeeps, dogs, communications equipment, mines and a variety of boats. The boats, which range in length from about 5 to 25 meters, are a collection of various types. Some are armed with 12.7-mm or 14.5-mm machineguns.

3. DEPARTMENT OF STATE SECURITY (DSE)

MININT has a third force which would aid MINFAR and other MININT forces during crises situations, the Department of State Security (DSE).

a. *General*

Originally known as the G-2, the Department of State Security (DSE) has been very successful in ferreting out and nullifying domestic opposition to the Cuban Government.

b. *Missions and Capabilities*

The DSE is charged with preventing counterrevolutionary activities, with investigating these activities, and with prosecuting the perpetrators. It also provides overall guidance to the civilian auxiliary forces, most of whom belong to the Committees for the Defense of the Revolution (CDR; see chapter 1, section B-3). The DSE is considered extremely capable of performing its missions.

In crisis situations, the DSE would probably be responsible for finding and neutralizing dissidents and spies. It would also probably be charged with interrogating prisoners of war.

c. *Strength*

The DSE has 10,000 to 15,000 personnel.

d. *Command and Control, Organization and Deployment*

Because of its importance, Fidel and Raul Castro exercise close control over the DSE. Its national headquarters is located in Havana. The DSE has considerable authority to arrest, search, question, and jail suspicious personnel.

The DSE is deployed throughout the country. Agents are assigned to conduct surveillance in collaboration with the local CDR units and the National Revolutionary Police. There is also a DSE unit stationed with the Eastern Army's Frontier Brigade at the US Naval Base at Guantanamo to control the Cuban citizens who work at the Naval Base.

e. *Composition*

The DSE is composed of very dedicated, highly indoctrinated and loyal personnel. Some of the personnel have military ranks. The DSE also employs covert agents.

f. *Training and Equipment*

Most, if not all, DSE personnel have had military training. Personnel are trained to use electronic surveillance equipment and interrogate prisoners. Some members could be used to augment the armed forces in an emergency, particularly in intelligence-related duties.

Section H—Civil Defense

1. GENERAL

The present civil defense organization traces its origins to Fidel Castro's National Revolutionary Militia (MNR). The MNR, established in October 1959, was a volunteer home defense force formed to counter threats to the newly established regime. In the early 1960s, the regular Army was expanded at the expense of the MNR. Some members of the MNR were incorporated into the regular Army while the rest were absorbed into the new military reserve organization, the Popular Defense Force. In June 1966, the Popular Defense Force was disbanded and its personnel was divided between two new groups, Civil Defense and the reserves. The Civil Defense units were then—and still are—trained to provide rear area security, while the reserves assumed the mission of the Popular Defense Force, that of aiding the regular Army.

Although the MNR is no longer functional (it was dissolved in June 1966), it is still recognized as an honorary organization and as a symbol of the Cuban Revolution; its members participate in parades in their dress uniforms (illustrated in chapter 6). Both Civil Defense and MNR members are called militiamen or militiawomen.

In November 1976, Civil Defense was organized into its present structure to conform to the newly proclaimed boundaries and responsibilities of the provinces and municipalities.

2. MISSION AND CAPABILITIES

The mission of the Civil Defense is to protect the population and the economic centers against the effects of all types of natural disasters and warfare. In the event of an emergency, Civil Defense is capable of aiding the population. During war, it would assist in providing for local defense and for rear area security.

3. STRENGTH

Civil Defense forces are estimated to include approximately 100,000 men and women.

4. COMMAND, CONTROL AND ORGANIZATION

As President of the Council of Ministers, Fidel Castro directs Civil Defense through MINFAR. MINFAR has jurisdiction over the organization, training and deployment of Civil Defense military units. The National Civil Defense Staff, which is subordinate to MINFAR (figure 3), is the principal command organ and is headed by the Chief of Staff of Civil Defense. The Chief of Staff, a MINFAR Colonel, is nominated by the Minister of FAR and appointed by the Council of Ministers.

Subordinate to the national level are the civil defense organizations in the provinces and the municipalities. From the national to the local level, individuals in positions of responsibility such as national, provincial and local heads of government and ministries, chiefs of factories and directors of schools, also have civil defense responsibilities. These leaders carry out their responsibilities under the supervision of civil defense staffs at their respective echelons.

Civil defense units oftentimes include representatives of other similar organizations, depending upon the need. For example, First Aid Units are composed of members of the Red Cross and the Ministry of Health.

5. COMPOSITION

Regular military personnel are assigned to Civil Defense staffs at least at the national and provincial levels. Civilian Cuban Communist Party members hold key positions throughout the organization. The remaining members—and by far the majority—are civilians who do not have any military rank. These civilians include both men and women who are not in the ready reserves and some who hold critical civilian production jobs.

Civil Defense is composed of both military and nonmilitary units. Units are established in many types of organizations, such as factories, and schools, as well as local, provincial and national government organs. Civil Defense military-type units are responsible for the protection and defense of the area or installation where they are located. There are several types of nonmilitary units which are grouped according to their functions, including salvaging and repairing damaged installations, rendering first aid, fighting fires, and maintaining production in key industries. Both the military and nonmilitary units cooperate closely with MININT's National Revolutionary Police and Firefighting and Prevention units.

6. TRAINING AND EQUIPMENT

Between 1973 and 1977, the number of Civil Defense training exercises increased. These exercises are held to pinpoint the responsibilities of all citizens in the event of a national emergency and to ascertain the readiness of the Civil Defense system. Scenarios of exercises have included all types of day and night enemy attacks, and have stressed defensive measure against NBC attacks. Soviet advisers have supervised some of these Civil Defense exercises.

The Nico Lopez National School of Civil Defense, located in Havana, is the senior civil defense school. This school provides training courses for civil defense cadre.

Equipment consists of such items as protective masks, protective clothing, decontamination equipment, and small arms, as well as trucks and equipment which have been mobilized from civilian agencies.

CHAPTER 3 THE CUBAN REVOLUTIONARY NAVY

Section A—Organization

1. HISTORICAL BACKGROUND

Prior to 1959, the US-trained and -equipped Cuban Navy effectively performed its primary mission of guarding Cuba's coast. Although the Navy did not actively participate in the anti-Batista, Castro-led revolution, about 400 naval personnel had staged an unsuccessful revolt at the Cienfuegos Naval Base in September 1957. After Castro seized power in January 1959, he initially allowed the Navy to remain relatively intact, largely because he believed that the Cienfuegos revolt was an indication of the Navy's potential loyalty to him. However, when it became apparent that the majority of naval personnel were really anti-Batista rather than pro-Castro, Castro purged the Navy, stripping it of virtually all its trained personnel by the end of 1960. Castro began to rebuild the Navy by restaffing it with a small nucleus of politically reliable personnel.

By mid-1961, Cuban naval personnel were being sent to the USSR for training and a large number of Soviet naval personnel were assigned to Cuba to serve as instructors and to help staff naval ships.

In 1962, the Cubans received 12 KOMAR-class Missile Attack Boats, 6 KRONSHADT-class Submarine Chasers, and 12 P-6 and 4 P-4 Small Torpedo Boats. Also in 1962, the Cuban Navy received its first SAMLET (SSC-2b) cruise missiles. Cuba has continued to receive additional craft and weapons from the Soviet Union over the years.

On 3 August 1963, the Cuban Revolutionary Navy (Marina de Guerra Revolucionaria or MGR) was officially dedicated and Cuba's Western Naval Flotilla was created. It was several years, however, before the MGR was able to assimilate completely its large amount of new equipment. In addition, it was not until after 1965 that Cubans, who had received training in the USSR, reached levels of significant operational responsibility. In April 1972, the Chief of the MGR was elevated to Deputy Minister (as was the Chief of the Air and Air Defense Force (DAAFAR)).

2. MISSIONS AND CAPABILITIES

a. *Missions*

The missions of the MGR are to defend the coast against invasion by sea, to provide Cuban fishing and merchant marine ships with escort protection to provide surveillance of territorial waters, and to prevent infiltration and exfiltration by sea. The MGR works closely with the Border Guard Troops (described in chapter 2, section G-2-b) in performing these functions.

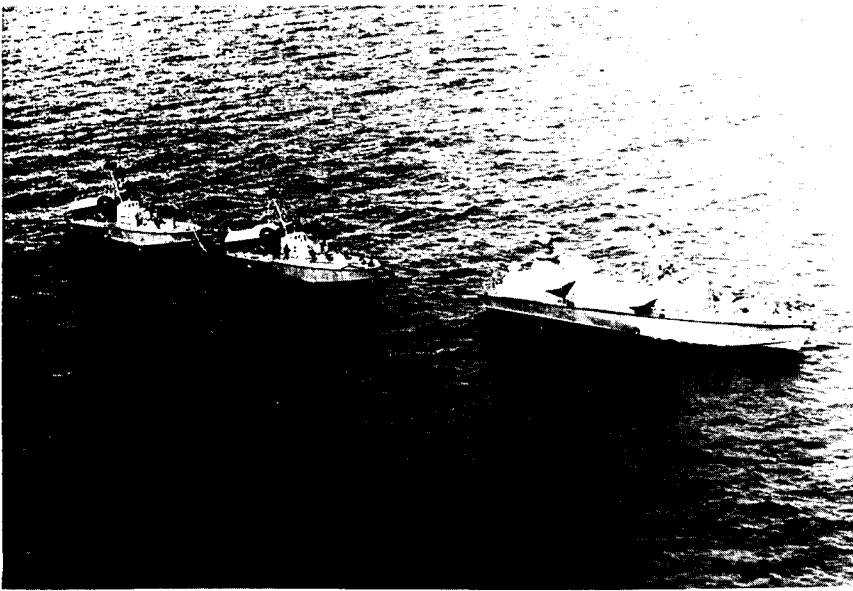

Two Cuban KOMARs (left) and an OSA-I Missile Attack Boat (PTG). Each KOMAR carries two STYX (SS-N-2) surface-to-surface missiles and the OSA carries four STYX missiles. The STYX has a range of approximately 40 km. The PTGs are the Cuban Navy's most potent vessels.



A P-4 Small Torpedo Boat (PTL) apprehending would-be refugees.

b. Capabilities

The MGR is the only significant naval force in the Caribbean, and one of the best-equipped and best-trained navies in Latin America. In terms of equipment and missions, it is a coastal defense force and consequently does not pose a threat to United States territory.

The MGR is capable of defending the island against invasion by other than a major power. Close cooperation by the MGR with the Border Guard Troops enables the Cubans to detect and intercept most seaborne infiltration and escape attempts. Due to the length of the Cuban coastline (3,735 kilometers), however, it is doubtful that Cuban forces are able to prevent all illegal entry and exit.

All of the MGR's ships are small and therefore have operational limitations. A primary problem is their short range, and the lack of an at-sea replenishment capability prevents extending the range. The small size of the vessels also hinders their ability to operate during rough weather.

The KOMAR and OSA Missile Attack Boats form the backbone of the Cuban Navy's defense capability. These craft carry the STYX (SS-N-2) surface-to-surface missiles which have a maximum range of approximately 40 kilometers. The STYX missile proved to be an effective weapon system in both the 1967 Arab-Israeli War, and in the 1973 Indo-Pakistani War.

The primary uses of the Cuban Submarine Chasers are patrol and escort. Since these vessels are the largest in the MGR, their longer range and seakeeping ability enable them to effectively perform these functions. The antisubmarine warfare (ASW) capability of the MGR is restricted due to the age of the KRONSHADT and SO-1 Submarine Chasers, which are more than 20 years old. Since Cuba did not acquire a submarine until early 1979, its ASW proficiency has been limited by the lack of a submarine to provide realistic training. The Cubans relied on occasional joint, rudimentary exercises during Soviet deployments. The Submarine Chasers are at a distinct disadvantage if challenged by nuclear or modern conventionally-powered submarines.

The single FOXTROT Attack Submarine has increased Cuba's antiship capabilities slightly. However, the diesel submarine, which is armed with torpedoes, can be detected by a naval force equipped with modern sonar instruments.

The small (at least 200 strong) marines have very limited ground and over-the-shore capabilities.

The P-6 and P-4 Small Torpedo Boats are also affected by age since their construction dates to the 1950s. The main weaponry carried by the PTL Boats are two "aimed" torpedoes which are used solely in an antisurface ship role. As with other MGR units, the principal peacetime function of the Small Torpedo Boats is patrol.

The MGR has a very modest mine warfare capability. Each KRONSHADT carries two stern-mounted mine racks. In addition, the P-6 Small

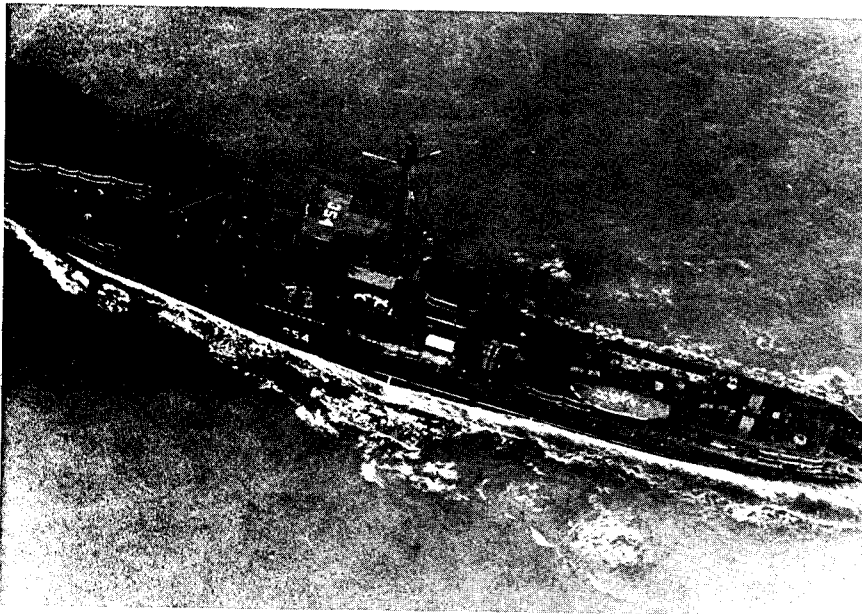

A KRONSHITADT Submarine Chaser (PCS). Cuba's antisubmarine warfare capabilities are limited because of old equipment and lack of realistic training exercises.

Torpedo Boats can be rigged to carry mines instead of torpedo tubes; however, no Cuban P-6s have been observed with this configuration.

To enhance their coastal defense capability, the MGR has an inventory of about 50 SAMLET (SSC-2b) cruise missiles. This weapon, which looks like a scaled-down, pilotless version of the MiG-15 FAGOT fighter, has been in the Soviet inventory since the late 1950s and in Cuba since about 1962. It is believed that this system has been deactivated because of its age but it would likely be deployed if needed to help counter a naval threat to Cuba.

The MGR is very dependent upon DAAFAR for anti-air protection. Its vessels have no fixed surface-to-air missile (SAM) launchers and only a limited number of anti-aircraft guns. Although it is possible that some ships carry the GRAIL (SA-7) shoulder-fired missile, the missile does not greatly upgrade the MGR's anti-air defense.

3. STRENGTH

The strength of the MGR is approximately 10,000 (1,000 officers and 9,000 enlisted). Of these, about one-fourth are believed to be assigned to units afloat; the remainder, to units ashore.

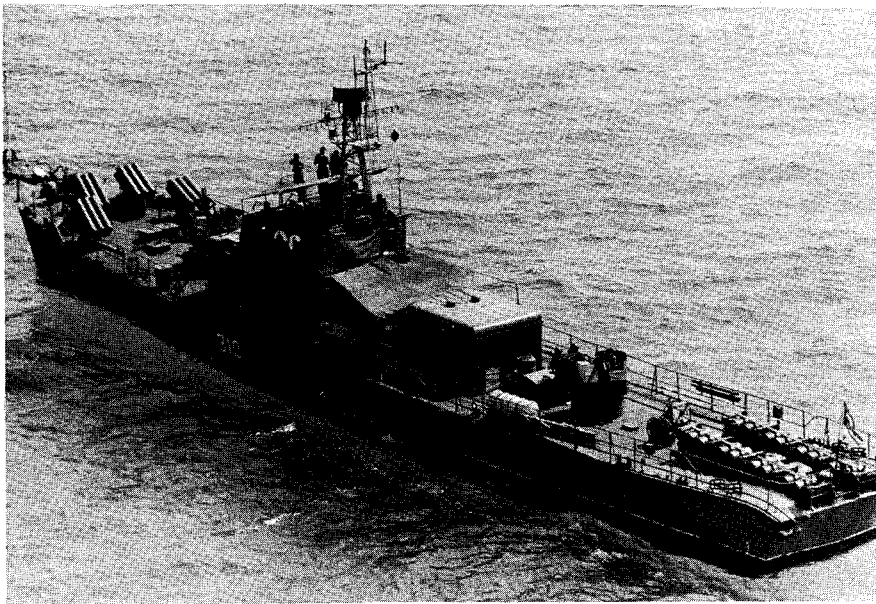

An SO-1 Submarine Chaser (PCS). Note the four 5-barreled antisubmarine warfare rocket launchers on the bow.

4. COMMAND AND CONTROL

Overall command is exercised by the Deputy Minister, Chief of the Revolutionary Navy, who is subordinate to the MINFAR First Deputy Minister, Chief of the General Staff (figure 3). The Cuban Revolutionary Navy is organizationally coequal service with the Air and Air Defense (DAAFAR).

The afloat units of the MGR are divided into separate flotillas according to ship type and these are further subdivided into squadrons. The major shore commands are the Surface-to-Surface Missiles (SAMLET) Forces, the Coastal Surveillance Forces facilities, the Mariel Naval Academy, the Center for Naval Specialist Training at Playa del Solado, and the Naval Support Facilities located at the Casablanca shipyard in Havana.

The MGR has a Western Flotilla, which is called the "Granma Landing Guard Flotilla," but information on other regional flotillas is not available. The regional flotillas may serve as an intermediate command between the MGR Headquarters and the operating forces.

5. IDENTIFICATION

The MGR uses the same Military Unit Number (MUN) systems and honorific names as do the other components of the Ministry of the Revolutionary Armed Forces.

Section B—Equipment and Logistics

1. NAVAL VESSELS

The MGR naval order of battle includes about 99 ships and craft. Expansion of the Cuban fleet depends upon future deliveries from the Soviet Union. The principal units and approximate inventory of the MGR are reflected in the following table.

Attack Submarine (FOXTROT)	1
Missile Attack Boats (OSA II, OSA I, KOMAR)	28
Submarine Chasers (KRONSHADT, SO-1)	14
Other Patrol and Torpedo Types (Soviet types including TURYA P-6, P-4 and former US PRs and PBs)	22
Medium Landing Craft (T-4)	6
Auxiliary Ships	4
Service Craft	<u>24</u>
Total ships (approximate)	99

Cuban naval vessels are depicted in appendix N; the characteristics of these ships are in appendix O.

2. MAINTENANCE

Major overhauls of naval ships are performed at the Casablanca Naval Shipyard in Havana, which is called the "Granma Military Enterprise of the MGR," where there are excellent facilities, highly qualified personnel, and probably Soviet advisers. Normally there is no backup of vessels in need of repairs.

Section C—Personnel and Training

1. PERSONNEL

MGR enlisted personnel are obtained through the General Military Service Law. Some women serve in enlisted and officer technical positions. Terms of service, promotion policies, pay, incentives, and discipline are generally the same

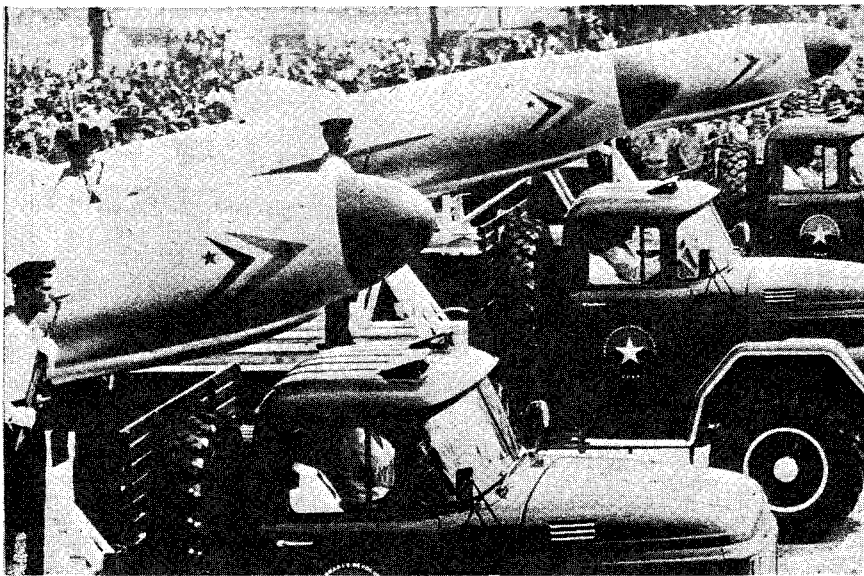

The SAMLET (SSC-2b) cruise missiles resemble a scaled-down, pilotless version of the MiG-15 FAGOT; The missiles have a range of about 80 kilometers.

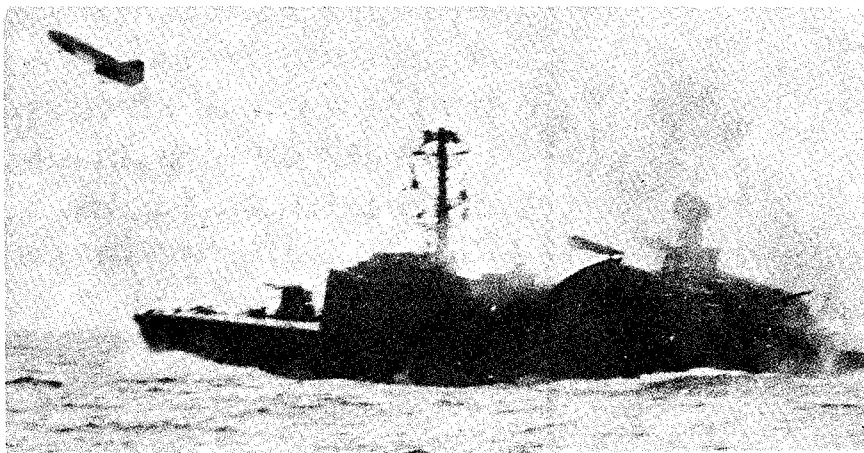

An OSA-I Missile Attack Boat (PTG) firing a STYX (SS-N-2) surface-to-surface missile.

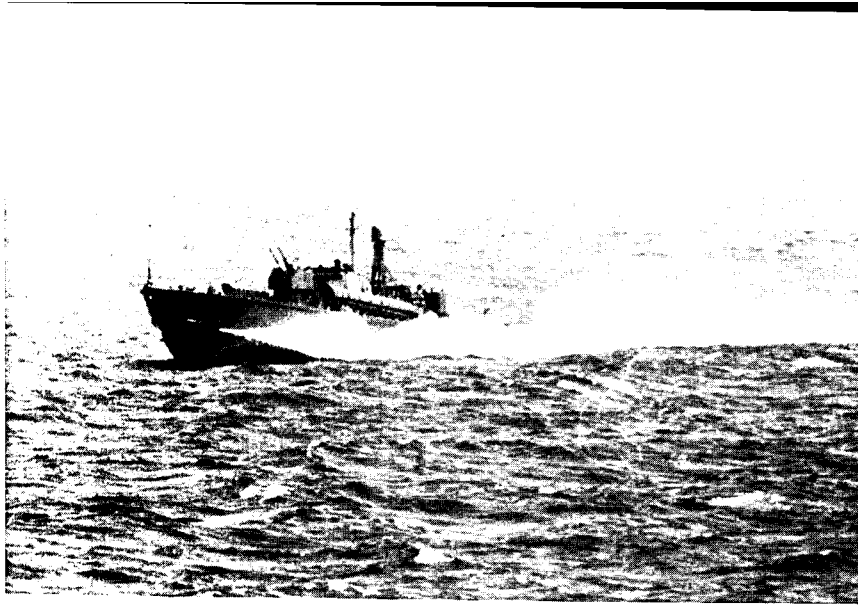

A P-6 Small Torpedo Boat (PTL). It is armed with two 533-mm torpedo tubes and two twin mounts of 25-mm guns, one forward and one aft.

as those for the ground forces. Table 5 presents the Spanish title, the literal translation and the approximate US equivalents of the Cuban naval ranks. Naval ranks and insignia are illustrated in chapter 6. There have been no recent reports of morale problems in the Navy and present esprit de corps is believed to be good. Extensions of active duty tours are solicited by the MGR, but currently available data do not indicate the effectiveness of this solicitation.

Table 5

Cuban Naval Ranks

<u>Spanish</u>	<u>Literal Translation</u>	<u>Approximate US Equivalent</u>
Almirante	Admiral	Vice Admiral
Vice Almirante	Vice Admiral	Rear Admiral
Contra Almirante	Rear Admiral	Commodore
Capitan de Navio	Frigate Captain	Captain
Capitan de Fragata	Frigate Captain	Commander
Capitan de Corbeta	Corvette Captain	Lieutenant Commander
Teniente de Navio	Navy Lieutenant	Lieutenant
Teniente de Fragata	Frigate Lieutenant	Lieutenant (junior grade)
Teniente de Corbeta	Corvette Lieutenant	Ensign
Alferez	Ensign	(No US Equivalent)
Primer Sub-Oficial	First Sub-Officer	Chief Warrant Officer
Sub-Oficial	Sub-Officer	Warrant Officer
Sargento de Primera	First Sergeant	Senior Chief Petty Officer
Sargento de Segunda	Second Sergeant	Chief Petty Officer
Sargento de Tercera	Third Sergeant	Petty Officer Second Class
Soldado de Primera	First Soldier	Seaman
Soldado	Soldier	Seaman Apprentice

The source for naval officers is the Mariel Naval Academy. Officers have no definite term of service and are released from active duty at the convenience of the MGR based on age, rank, length of service, and needs of the service. Within the officer corps, political loyalty to Castro and to the Party are important prerequisites for advancement. This is reflected by the fact that about 85 percent of the MGR's officers are members of either the Communist Party or Union of Young Communists.

2. TRAINING

As in the other branches of the FAR, the MGR enlisted personnel are generally well trained. Cuba's high literacy rate precludes the need for providing recruits with basic educational skill. Enlisted personnel probably receive 6 to 8 weeks of basic training immediately after induction.

Specialized training for enlisted personnel is conducted at the Center for Naval Specialist Training (Centro de Preparacion de Especialistas Navales—

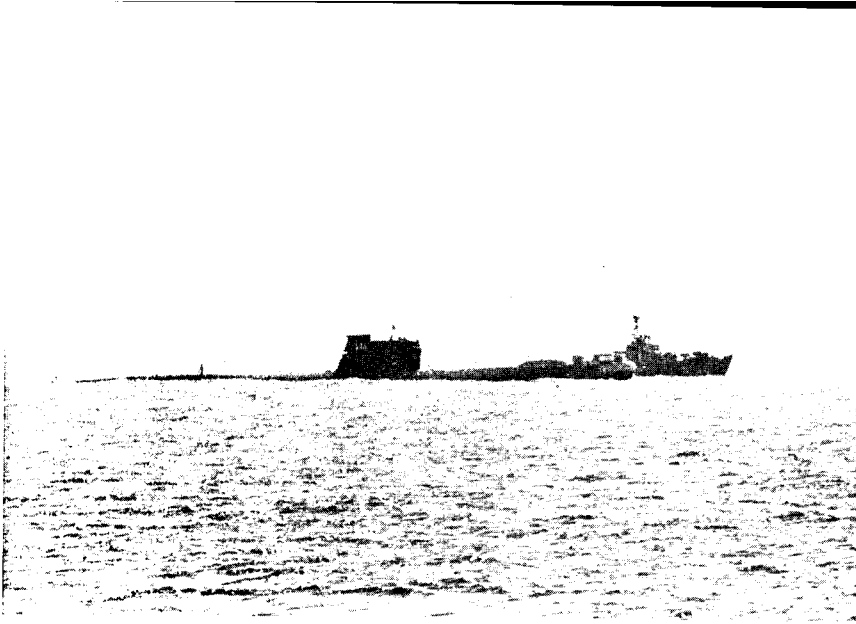

A Soviet FOXTROT Class Submarine, which is a diesel-powered attack submarine that carries 20 nonnuclear torpedos, and a Cuban SO-1 Submarine Chaser (PCS) during a joint antisubmarine warfare exercise.

CPEN) at Playa del Solado. Students specialize in naval missiles, deck seamanship, electronics, naval motors, radio telegraphy, signal training, sonar, radar, and navigation.

Dating back to 1916, the Naval Academy located at Mariel is Cuba's oldest service academy. The current enrollment is 1,300 to 1,700 students; of these, 800 to 1,000 are preparing for the MGR and 500 to 700, for the Merchant Marine.

Beginning with the 1977-78 academic year, the MGR instituted a new curriculum for the midshipmen attending the Naval Academy. These are for 5-, 4-, and 2-year terms of study.

The 5-year course prepares midshipmen to be engineering officers. They specialize in naval engineering, radar directed weapons, and diesel power plants. Candidates must be unmarried males between 17 and 21 years who have successfully completed their preuniversity studies.

The 4-year course is for prospective line officers. These midshipmen study navigation, artillery and missiles, mines, torpedoes, antisubmarine warfare weapons, radio communications, and diesel power plants. Applicants must be single males between 16 and 21 years who have successfully completed preuniversity studies.

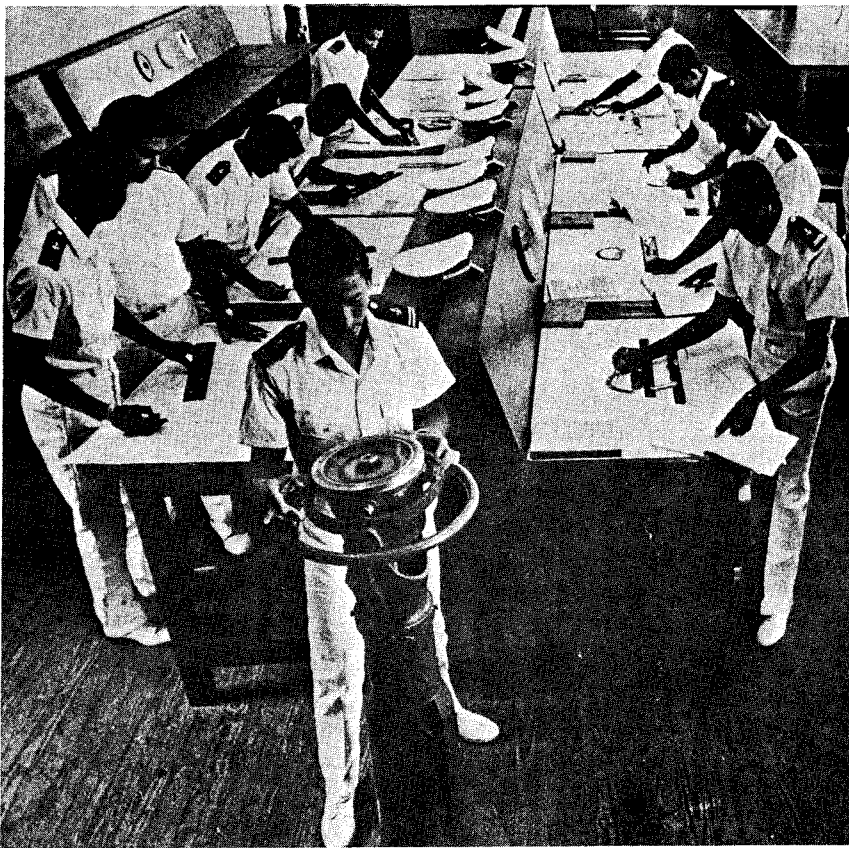

A class on navigation at the Mariel Naval Academy.

The 2-year course is believed to prepare midshipmen as electronics officers. The subjects are the same as those studied by the line officers, except that the course does not include diesel power plants, and probably less time is spent on the other subjects. The entrance requirements are the same as those for line officers.

All midshipmen study Russian, politics, ideological theory, and general academic courses, and participate in end-of-year training cruises. Prior to the curriculum reorganization, the Naval Academy had a 4-year course for prospective Merchant Marine officers to prepare them as line engineering officers. Information is not available concerning the new programs for these students.

In addition to training in Cuba, selected MGR officer and enlisted personnel are schooled in the Soviet Union. Courses offered include a 5-year program for engineering officers.

The MGR usually participates in at least one major interservice exercise a year and conducts joint training exercises with units of the Soviet Navy during their periodic visits to Cuba.

Section D--Reserves and Mobilization

The MGR is believed to have an effective reserve force which would be activated during times of crisis. Former MGR personnel have a reserve commitment until the age of 50; no information is available concerning periodic reserve training.

It is likely that the personnel and vessels of the Border Guard Troops and Institute of Hydrography would come under the command of the MGR during crises. The Border Guard Troops have approximately 3,000 personnel and probably more than 100 small patrol craft. Data regarding the strength of the Institute of Hydrography are not available.

Both the Cuban Merchant Marine and the fishing fleet would probably come under MGR control during a crisis. The Merchant Marine has 72 ships of at least 1,000 gross registered tons, totaling approximately 700,000 deadweight tons (dwt). It is estimated that there are 4,000 to 4,500 seagoing personnel in the Merchant Marine. In addition, the fishing fleet has approximately 10,000 seagoing personnel on some 230 vessels with a total of 168,000 dwt. These fishing craft could be used for coastal patrol if required.

CHAPTER 4 THE CUBAN AIR AND AIR DEFENSE FORCE

Section A—Organization

1. COMPOSITION AND STRENGTH

The Cuban Air and Air Defense Force (Defensa Antiaerea y Fuerza Aerea Revolucionaria or DAAFAR) is estimated to have 12,000 to 15,000 personnel organized in four elements: the Cuban Revolutionary Air Force, Surface-to-Air Missile Forces, Air Surveillance Forces, and Air Defense Artillery (ADA) Forces.

2. HISTORICAL BACKGROUND

Raul Castro established the Rebel Air Force on 12 April 1958 in Eastern Cuba when the Castro guerrillas were fighting ex-dictator Fulgencio Batista. It consisted of one single-engine aircraft, used primarily for communicating with exile groups in Miami. By late 1958, a few additional planes were acquired and at least one bombing mission had been flown. Upon seizing control of Cuba in January 1959, Fidel Castro purged Batista's air force, leaving only a nucleus of loyal personnel. From this core, the new Cuban Air Force was established at San Antonio de los Banos Air Base, Havana Province. This small force, flying aging US aircraft, played a pivotal role in defeating the invaders at the Bay of Pigs; consequently, 17 April 1961 is now observed as DAAFAR organization day.

In mid-1961, the Soviet Union began to supply equipment to DAAFAR. Now, virtually all items of equipment in the DAAFAR inventory are of Soviet manufacture.

Initially an Army element, DAAFAR gained full service recognition in April 1972 with the elevation of the DAAFAR commander to the deputy minister level.

3. MISSIONS AND CAPABILITIES

a. *Missions*

The missions of the Air and Air Defense Force are to provide air defense for Cuba, tactical and airlift support for military forces, and aid or assistance to selected foreign countries and groups.

b. *Capabilities*

The air defense elements of DAAFAR—interceptors, surface-to-air missiles, radar systems and air defense artillery—provide Cuba with a formidable, integrated, and closely coordinated defense against air attack.

The tactical elements of the Air Force are the best equipped and best trained in Latin America. The Air Force also has a well-trained air transport



One UMiG-21 MONGOL (top) and three MiG-21 FISHBEDs flying in formation. All are armed with the pencil-thin ATOLL AA-2b air-to-air missiles. The UMiG-21 MONGOL is an armed two-seater trainer. The MiG-21 FISHBED is the principal Cuban Air Force aircraft.



This is the MiG-23 FLOGGER F, which is a ground attack/interceptor. Cuba has at least 8 FLOGGER Fs and one FLOGGER C, which is a two seater that can be employed for training and combat. Both models were acquired during 1978.

element capable of meeting ordinary day-to-day needs of the Cuban military. As organized and equipped, however, it cannot support long-range, large-scale troop movements even when augmented by the national airline, Cubana.

4. COMMAND AND CONTROL

With headquarters located at Ciudad Libertad Air Base near Havana, DAAFAR is broken down into three zones: Western, Central and Eastern. Information concerning the zone boundaries is not available.

5. IDENTIFICATION

DAAFAR uses the same Military Unit Number (MUN) system and honorific names as do the other components of the Ministry of the Revolutionary Armed Forces.

Section B—Equipment and Logistics

1. EQUIPMENT

The current Air Force inventory includes MiG-15, 17, 21, and 23 aircraft, armed with a combination of weapons systems. The Air Force also has medium- and short-range transport aircraft, as well as attack and medium-lift helicopters.

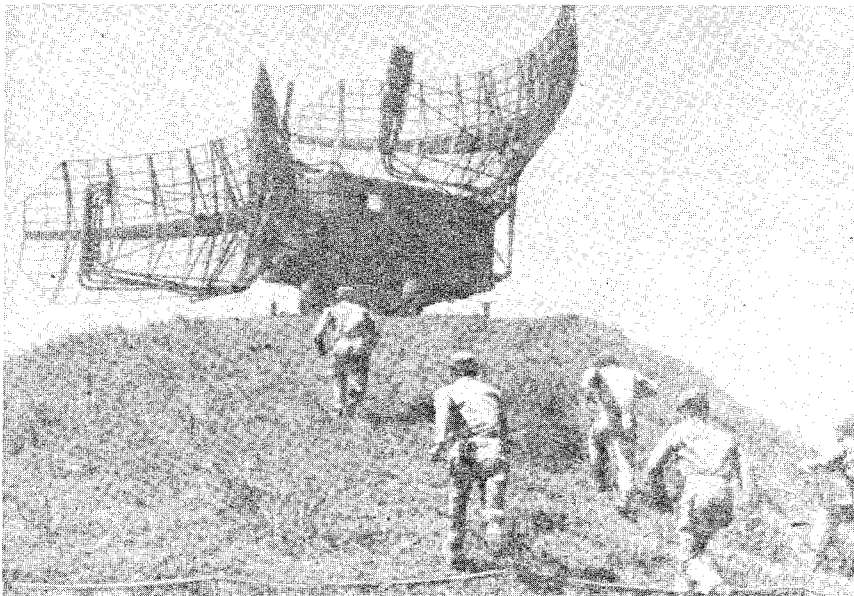

Members of Air Surveillance Forces run to man a BAR LOCK B radar, a ground control intercept (GCI) and search radar, used in conjunction with SA-2 GUIDELINE missiles.

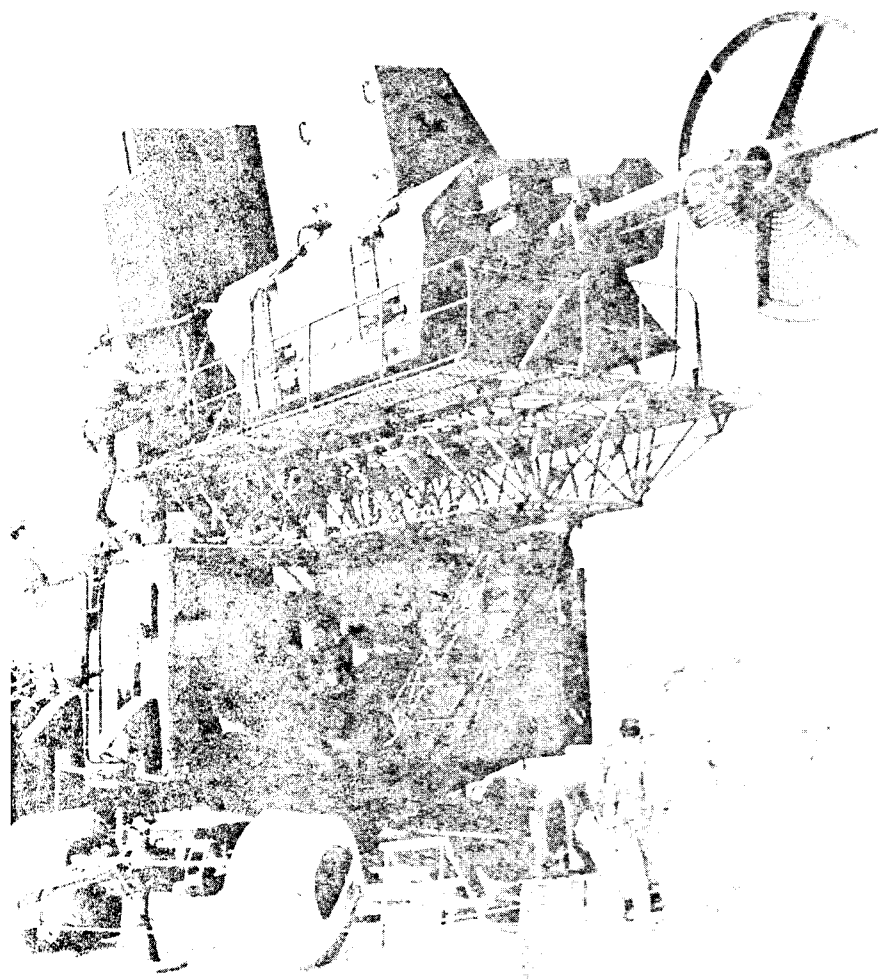

The FAN SONG F radar, used with the SA-2 GUIDELINE missile, is responsible for the detection and tracking of the target, the command guidance of the missile, and the tracking of the missile. It is manned by members of the Air Surveillance Forces.

Illustrations and selected technical characteristics of these aircraft are presented in appendixes P and Q, respectively.

Cuba's operational surface-to-air missiles include SA-2/GUIDELINE and SA-3/GOA with their associated equipment and radars. These are illustrated in appendix R. The shoulder-fired SA-7/GRAIL is illustrated in appendix M.

Air defense weapons vary from 12.7-mm to 100-mm guns and include both towed and mobile systems. They are also illustrated in appendix M.

Cuba's Air Surveillance Forces are equipped with various Soviet radars, including the FAN SONG, TALL KING, FLAT FACE, SPOON REST, and BAR LOCK.

2. SUPPLY

Since its inception, DAAFAR has received the vast majority of its supplies and equipment from the Soviet Union. The Rear Services at MINFAR Headquarters plans and coordinates logistical support for all common items of supply. Supply and distribution of these items and responsibility for all DAAFAR-related items rest with the Rear Services element of DAAFAR.

3. MAINTENANCE

With some Soviet technical support, particularly for the newer and more sophisticated weapons, DAAFAR is capable of maintaining all of its weapons in acceptable operational status. Since 1972, the Air Force maintenance facilities at the "Great October Socialist Revolution" Military Enterprise and the "Yuri Gagarin Friendly Combat" Aviation Repair Depot have been greatly expanded and improved. Additionally, support-level maintenance facilities probably are located in each of the three zones.

Section C—Personnel and Training

1. PERSONNEL

Enlisted personnel for DAAFAR are procured through the Compulsory Military Service Law. Officer candidates are selected on the basis of performance in competitive examinations. DAAFAR personnel, particularly the pilots, are considered the elite of the Armed Forces. Some women serve in enlisted and officer technical positions. Table 6 presents the Cuban Air Force ranks in Spanish, their literal translation and their approximate US equivalents. Other DAAFAR personnel, especially those in Air Defense Artillery, have Army rank and insignia (table 2). The ranks are illustrated in chapter 6. Terms of service, promotion policies, pay, incentives and discipline are generally the same as those for the ground forces personnel.

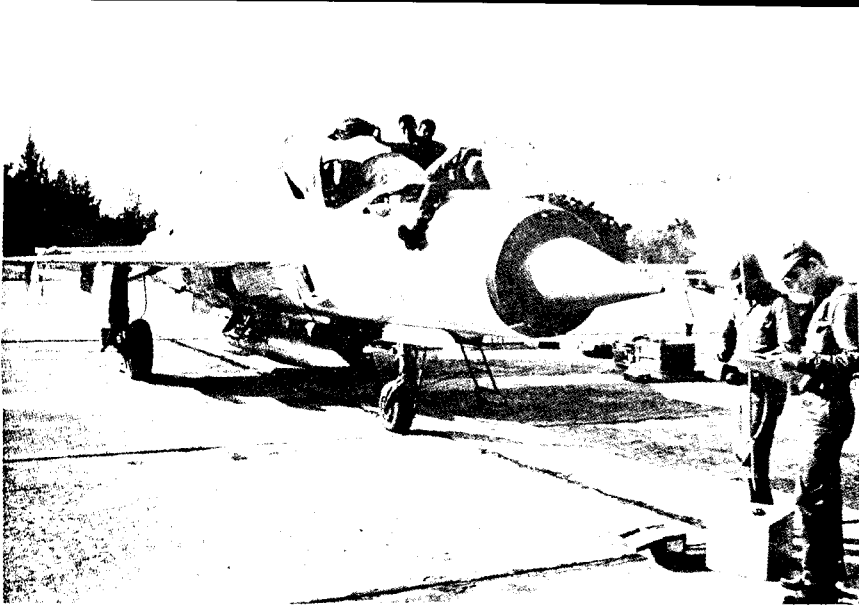

Ground crews perform maintenance on a MiG-21 FISHBED.

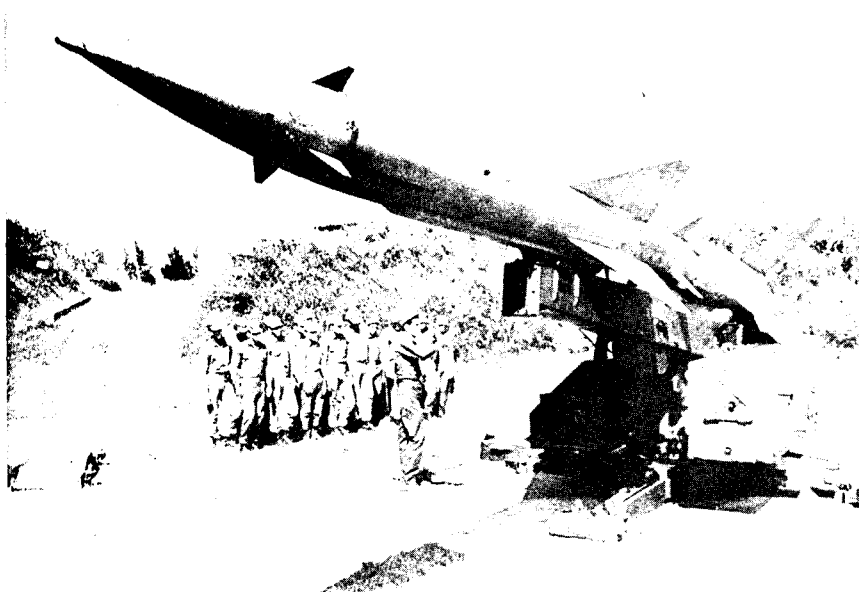

Personnel attend class instruction on the SA-2 GUIDELINE missile.

2. TRAINING

DAAFAR personnel are well trained to carry out their assigned missions; however, there is little cross-training. Although the majority of the training is conducted in Cuba, many enlisted and officer personnel have received training in the Soviet Union.

a. *Enlisted Training*

Enlisted personnel must have at least a sixth-grade education to enter DAAFAR. After basic training, recruits enter one of the DAAFAR specialist schools. The principal enlisted school is the DAAFAR Specialist Training Center in Havana Province which trains personnel for various jobs such as missile technician, engine mechanic and fuselage mechanic. Technical training is also conducted at the unit of assignment. Enlisted air defense artillery training probably is conducted principally at the unit level.

b. *Officer Training*

Prospective officer personnel enter DAAFAR with a minimum tenth-grade education; some programs, such as pilot training, require completion of senior high school (13th grade). Pilots are trained in the Soviet Union and Cuba. The pilot training course in the Soviet Union takes approximately 4 years. An alternative course includes 1 year of aviation training in Cuba followed by 3 years of training in the USSR. The Military Technical Institute at Mariano, Havana City, trains technical personnel in 4- and 5-year courses and graduates receive a degree in their specialty. ADA officers receive training at the Major Camilo Cienfuegos Artillery School, La Cabana Fortress, Havana City. Training for mid- and senior-level DAAFAR officers is provided at the General Maximo Gomez FAR Academy, Havana Province.

c. *Unit Training*

Like that of the Army, DAAFAR training is conducted year-round. At least one major and a few smaller interservice exercises are usually held each



An SA-3 GOA is fired in the field. The SA-3 GOA is a low- to medium-altitude air defense missile.

year. Fighter squadrons spend the majority of their training time on ground-controlled intercept (GCI) proficiency, but also devote some time to their ground support role.

Table 6

Cuban Air Force Ranks

<u>Spanish</u>	<u>Literal Translation</u>	<u>Approximate US Equivalent</u>
Comandante en Jefe	Commander in Chief	General of the Air Force
General de Ejercito	Army General	General
General de Cuerpo de Ejercito	Army Corps General	Lieutenant General
General de Division	Division General	Major General
General de Brigada	Brigade General	Brigadier General
Coronel	Colonel	Colonel
Teniente Coronel	Lieutenant Colonel	Lieutenant Colonel
Mayor	Major	Major
Capitan	Captain	Captain
Primer Teniente	First Lieutenant	First Lieutenant
Teniente	Lieutenant	Second Lieutenant
Sub Teniente	Sub Lieutenant	(No US Equivalent)
Primer Sub-Oficial	First Sub-Officer	Chief Warrant Officer
Sub-Oficial	Sub-Officer	Warrant Officer
Sargento de Primera	First Sergeant	Senior Master Sergeant
Sargento de Segunda	Second Sergeant	Master Sergeant
Sargento de Tercera	Third Sergeant	Staff Sergeant
Soldado de Primera	First Soldier	Airman First Class
Soldado	Soldier	Airman

Section D—Reserves and Mobilization

Personnel who serve in DAAFAR have a reserve obligation. Reservists make up a large part of DAAFAR's air defense artillery force. Additionally, Cubana Airlines personnel and equipment can be integrated into the operation of the Air Force in a matter of hours. The addition of Cubana's pilots, navigators, maintenance personnel and approximately 40 transport aircraft would significantly enhance the Air Force's airlift capability.

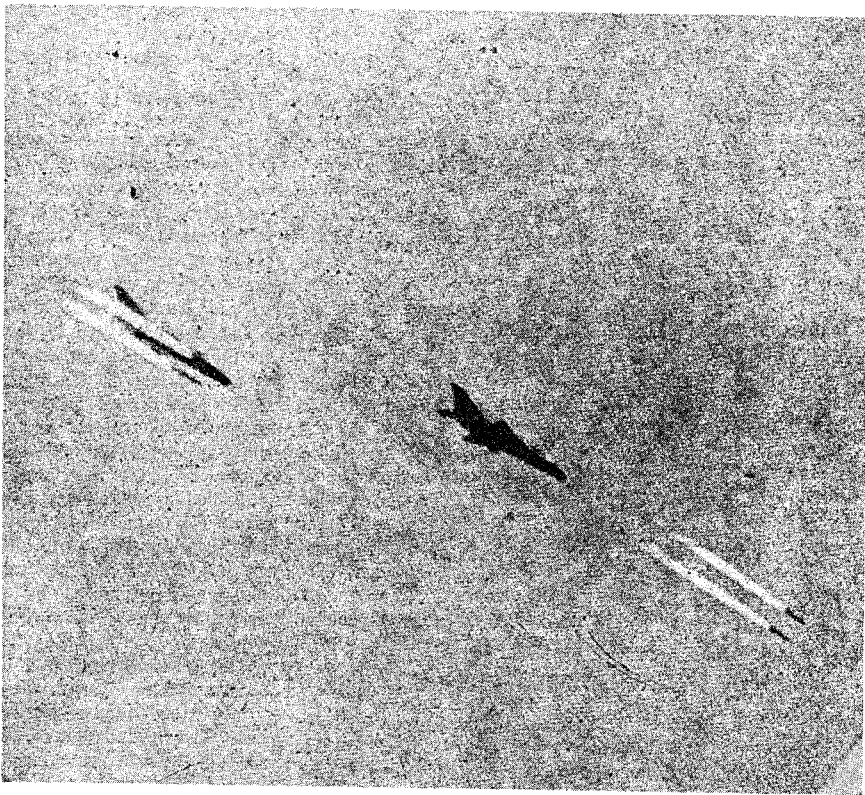

MiG-21 FISHBEDS provide ground support.

Section E--Civil Aviation and Air Fields

1. CIVIL AVIATION

The government-owned civil airlines, Cubana, is subordinate to the Ministry of Transportation. It owns an estimated total of 38 civil transport aircraft, each at least 9,000 kilograms gross weight:

- 4 Bristol (B.A.C.) Britannia 318
- 9 An-24B (COKE)
- 11 I1-14 (CRATE)
- 4 I1-18 (COOT)
- 4 I1-62 (CLASSIC)
- 6 Yak-40 (CODLING)

Cubana employs approximately 1,775 personnel, of which at least 100 are pilots and copilots and about 30 to 50 are navigators and flight engineers. Training for these personnel is the responsibility of the Civil Aeronautics Institute.

Cubana has aircraft repair and maintenance facilities; however, aircraft are returned to the United Kingdom and the Soviet Union, respectively, for major overhaul. The civil air arm, like the military, depends on the USSR for support. Any interruption of Soviet assistance would severely limit the capabilities of civil aviation in a prolonged military emergency.

2. AIRFIELDS

Cuba has approximately 180 useable airfields located throughout the island with the exception of the mountainous areas in western, south-central and southeastern Cuba. Each province and the Isle of Youth have at least one permanent airfield. There are 11 joint civil-military and five military airfields, all of which are major permanent facilities. Only six airfields have permanent runways over 2,500 meters: Guantanamo Airfield; Holguin Airport; Santa Clara Airport; Jose Marti International Airport; San Antonio de los Banos Airport (Havana Province); and San Julian Airport (Pinar del Rio Province).

CHAPTER 5 MILITARY STRATEGY AND TACTICS

Section A—Introduction

1. GENERAL CONCEPTS

Three primary factors have molded Cuban military strategy and tactics. The first was the adoption of Soviet military strategy and tactics, with modifications to suit the smaller and less sophisticated Cuban forces. The second has been the fear of an invasion either by the United States or by Cuban exiles. Although the fear of a US invasion has diminished, particularly since the late 1960s, repelling a large-scale invasion is still the principal theme of all major and most smaller military exercises. The third factor is Cuba's willingness to extend "international support" to viable friendly Socialist countries and movements.

2. TERRAIN AND CLIMATE

a. *Terrain*

Cuba is about 1,200 kilometers long with a maximum width of about 200 kilometers. More than half of the long, narrow island consists of flat or rolling agricultural lands (figure 9). The most extensive mountainous zone of the island lies near its eastern extremity. Smaller mountain zones are located in the midsection and the far west. Numerous short and rapid rivers run from the mountains, and although they provide good drainage, they are, for the most part, not suitable for navigation.

Small low islands or reefs of sand and coral parallel both the northern and southern coasts; however, a number of excellent harbors indent the shoreline. Cuba has a median elevation of no more than 100 meters above sea level, and its three principal mountainous zones are isolated and separated by plains.

The loftiest mountain system is the Sierra Maestra, which skirts the southeastern coast line west of Guantanamo Bay except where it is broken by the small lowland depression on which Santiago de Cuba is located. It is the most heavily dissected and steepest of the Cuban ranges and includes Pico Turquino (Turquino Peak) which, at 2,180 meters, is the country's highest elevation. On the east, the Sierra Maestra ends in the low area just west of the United States Naval Base at Guantanamo Bay. The lowlands around Guantanamo mark the end of the 96-kilometer long Central Valley, which runs west-northwest from Guantanamo to merge with the plains in west-central Cuba.

The mountains of Central Cuba, less extensive and of lower elevation than those of the east, occupy the southern portion of Sancti Spiritus and Cienfuegos Provinces. The two principal systems, the Sierra de Trinidad and the Sierra de Sancti, are separated by the Agabama River.

The principal ranges of the western highlands are the Sierra del Rosario, which begins in western Havana Province and extends southwestward along the

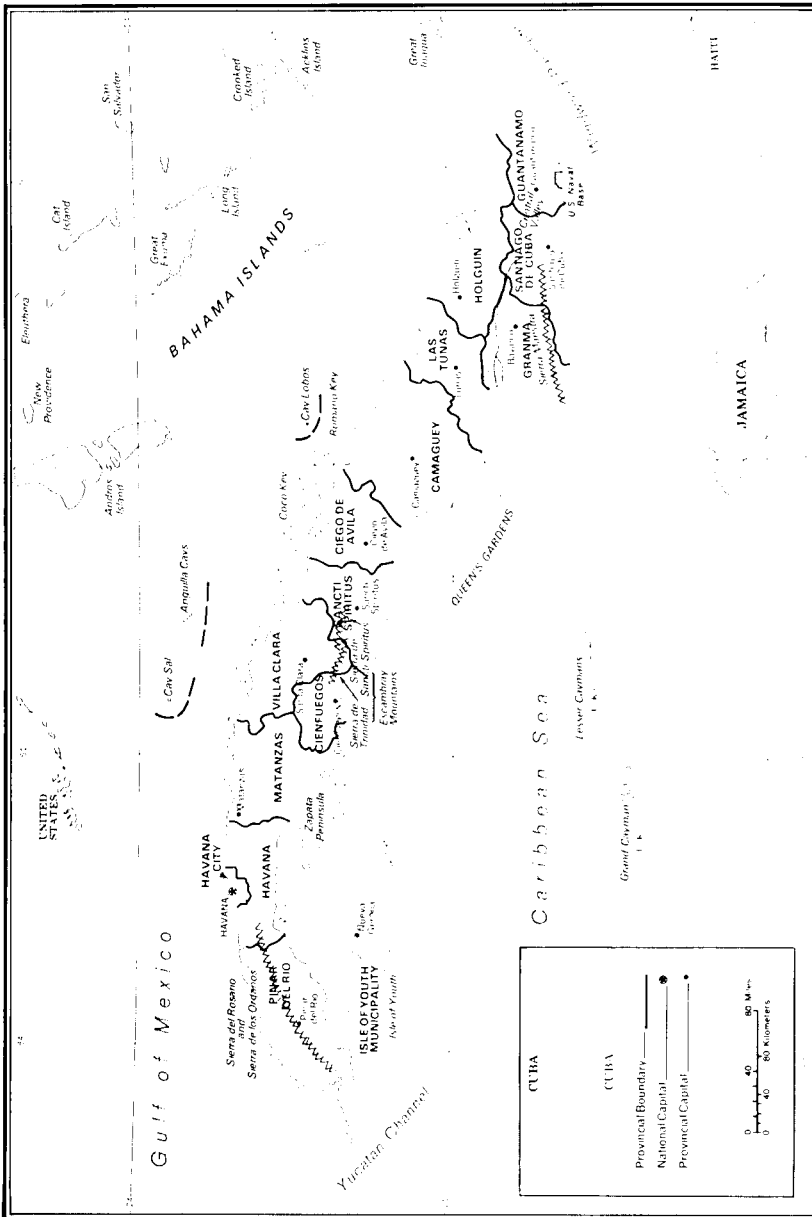

IDR 768062 / 9

Figure 9. Location of Some Cuban Terrain Features.

spine of the island for about 96 kilometers, and the Sierra de los Organos, which also runs from the western tip of the island eastward to the vicinity of Havana Province. These western highlands are limestone, weathered into strange shapes and are dotted with numerous sinkholes, caverns, and underground streams.

Most of the country's more than 200 rivers originate in the interior near the island's watershed and flow northward or southward into the sea. River levels rise significantly during the rainy season, when 80 percent of their flow occurs. Seasonal flooding is common. The longest river in Cuba is the Cauto River which rises in the Sierra Maestra near Santiago de Cuba and flows westward, where it forms part of the border between Granma and Las Tunas Provinces. Rivers are most numerous in the eastern provinces.

Seven subterranean river basins constitute the sources of many surface rivers, and there are extensive reservoirs of underground water. There are no large natural lakes, but the government has built many dams for irrigation. The coastal swamplands are numerous and extensive; the largest covers the Zapata Peninsula in southwestern Matanzas Province. Others are located in both the northern and southern coasts and on the Isle of Youth (Isle of Pines, until its renaming in July 1978).

b. *Climate*

Cuba has a mild tropical climate that is described as trade wind tropical, or, because of its relatively light rainfall, dry tropical. The mean temperature for the country is about 25° C (77° F) in winter and 27° C (80° F) in summer. Summer readings of as high as 38° C (100° F) have been recorded, and occasional freezing temperatures occur in mountain areas. Temperature drops below 10° C (50° F) are fairly frequent.

The relative summer humidity averages 65 percent in the daytime and 85 percent during the night. The winter humidity range is from 65 to 75 percent during the day and from 85 to 90 percent at night. An increase in humidity is observed at higher elevations in combination with relatively lower temperatures. Most of the country experiences a rainy season from May through October, when three-fourths of the annual precipitation occurs. Annual precipitation ranges from about 100 to 180 centimeters in the coastal areas and from about 130 to 150 centimeters in the interior. The amount of rainfall varies substantially from year to year, and droughts have been fairly frequent. The equatorial low-pressure zone influences the quantity and distribution of precipitation during the rainy season. Hurricanes occur as early as May and as late as December; most occur from August through October.

Cloud cover does not vary greatly throughout the year except for a slight increase during the wet season. Skies are seldom completely clear for extended periods of time. Maximum cloudiness generally occurs in the afternoon and is usually cumuliform with bases near 600 meters and tops about 3,000 meters. Thunderstorm tops, however, are considerably higher. Visibility normally ranges between 4 and 7 kilometers.

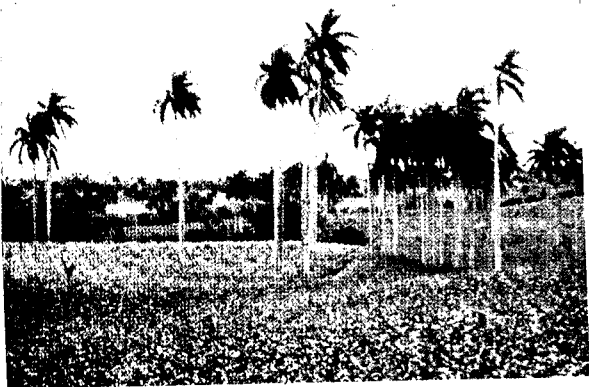

Rolling plains are typical features in Central Cuba. Scattered palm trees and low vegetation afford little cover or concealment; however, surface irregularities would provide some cover from flat-trajectory fire and concealment from ground observation.

Isolated, flat-to-rolling valleys interrupt the steep-sided hills in western Cuba. Hard limestone hills called *mogotes* tower above the softer shale rocks that underlie the cultivated plains and valleys. The *mogotes* usually have near-vertical sides and contain many caves, sinkholes, and underground streams.



The hills and mountains north of Trinidad, Sancti Spiritus Province, are steep-sided and rugged. Good concealment would be provided by surface irregularities and areas of scrub and broadleaf evergreen forest.

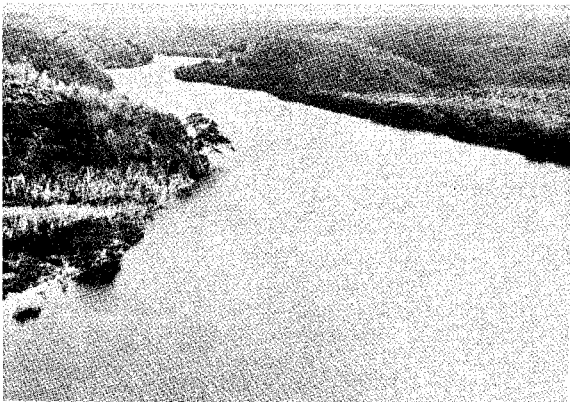

The lower reaches of many of the larger streams throughout the western and central lowlands are similar to this one. High, steep banks and large estuaries are common in areas of dissected plains.

Mangrove swamps border large coastal areas around Cuba and the Isle of Youth. Mangrove trees are generally closely spaced and supported by a thick tangle of prop roots.

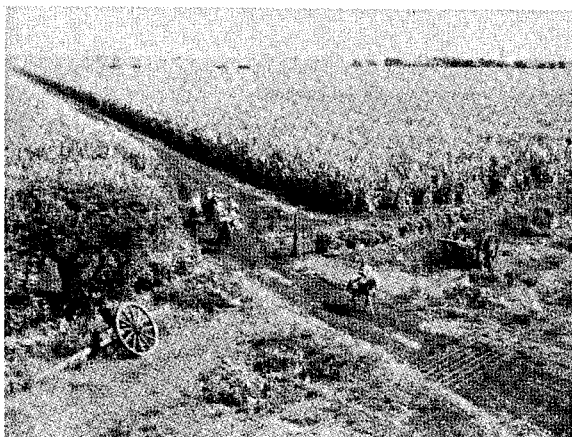

Sugarcane, the predominant crop, occupies about half of the plains. When mature, the cane is about 14 feet high, very dense, and highly susceptible to conflagration.



Rice is cultivated in scattered areas of western and central lowlands. Conventional military operations would be difficult when the fields are flooded.

Reinforced concrete and masonry buildings are prevalent in Havana City.



Rural houses are usually constructed of adobe or wood with thatched roofs and earth floors.



This mountainous terrain north of Guantanamo is covered by thick stands of tall broadleaf evergreen trees which form closed canopies.

Buildings of stucco-coated brick or masonry are common in the towns of Cuba. Most are single story and have tile floors, and tile or metal roofs.





The dwellings in the foreground are typical of most poorer sections in large urban areas in Cuba.

The rugged Sierra Maestra parallels the southern coast west of Guantanamo and contains the highest peaks in Cuba. This is the best area for irregular force operations because of the low population density and the difficult conditions for movement of conventional forces.

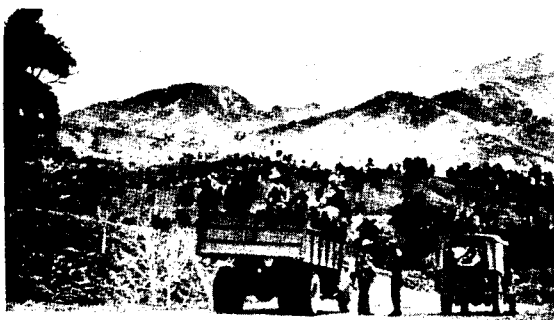

Many streams in the eastern highlands lie in deeply incised valleys. The evergreen and scrub forests in this area would provide good concealment. Conventional military operations would be difficult.

c. *Vegetation*

Crops and grasses cover most of the lowlands and the western and central highlands. Sugarcane is extensively produced throughout the plains. Smaller areas are devoted to tobacco, henequen, bananas, orchards, and rice. The widespread grasslands include natural and seeded pasture; many grasslands are dotted with palms and other trees, with patches of scrub trees. Forests are restricted largely to the highlands and some coastal lowlands. Broadleaf evergreens are the principal tree but pines are abundant, particularly in the west. Undergrowth is generally heavy.

3. SETTLEMENT PATTERNS

As of 1970, well over half of the population was classified as urban. The population of the plains and the western and the central highlands is highly urban, with much of it concentrated in a few large cities, particularly Havana. Cities and large towns are characterized by a central plaza, a rectangular street pattern, and one- to four-story buildings. Havana, however, has several 30-story buildings. Streets are generally wide and paved except in the outskirts. The principal construction materials are stone masonry, wood and stucco-coated brick; some of the more modern structures are of reinforced concrete and glass. Many smaller urban settlements dot the landscape; most are located at or near the country's more than 150 sugar mills. In the majority of the smaller towns, only the plaza and the main street are surfaced, and buildings are single story. Urban concentrations in cooperative and state-owned farms consist of simple wooden or precast concrete dwellings built along narrow, paved streets. Much of the rural population still lives in isolated, thatched dwellings.

Since 1959, the government has encouraged the population to move out of the urban areas, particularly Havana, in order to develop the rest of the country. According to 1975 statistics, Havana City Province has the largest number of people, 1,900,000, or almost 20 percent of the country's entire population. According to 1970 statistics, there are eight municipalities with over 100,000 population; the largest are Santiago de Cuba (324,500), Camaguey (214,500), Holguin (175,500) and Guantanamo (166,000) (A municipality equates approximately to a US county).

Section B—Basis of Tactics

1. COMMAND, CONTROL AND COMMUNICATIONS

a. *Command and Control*

The command and control structure for the Cuban defense establishment from the Commander-in-Chief to the corps level was discussed in chapter 2, section A. Below that level, headquarters and command posts probably are established much like those in US forces at comparable levels. Combat orders and instructions are prepared by staffs based upon doctrine, instructions from higher headquarters, and the commander's guidance. Oral orders, confirmed by fragmentary written orders and overlays, are normally used at division and lower



Inside a mobile command post.

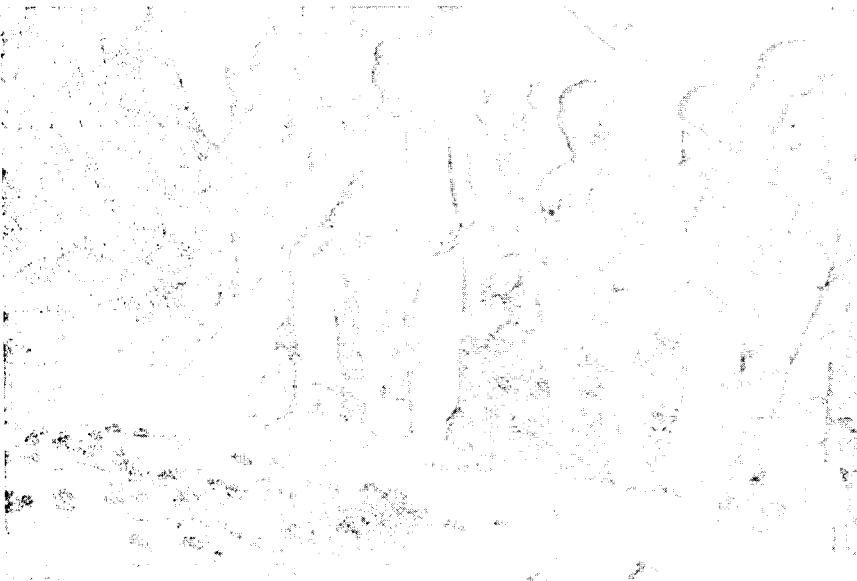

The battalion commander explains the tactical maneuver to his staff and company commanders.

echelons. Continuity of command is assured by providing main, alternate, forward and rear command posts (CPs) at division and higher levels. Division and regimental headquarters would be located well forward in order to maintain control of the battle. A unit commander at regiment or battalion level has very little flexibility in carrying out orders. Company, platoon and squad leaders must follow their orders strictly.

b. *Communications*

The Cuban ground forces use both AM and FM communications equipment, the majority of which probably is mid-1950s to mid-1960s generation equipment. Detailed information concerning Cuban communications procedures is not available; however, the Cubans are very concerned with communications security and employ strict security measures. Extensive use is made of wire. Radio and radioteletype communications are used less than in comparable US units. Radio operators are trained to follow strict procedures. Radio silence is strictly enforced, particularly during movement except to pass important reconnaissance reports and issue warnings. Emphasis is placed on extensive coordination of all operations and visual signals are used to reduce the need for radio communications. Radio antennas are frequently remoted.

2. TACTICAL PRINCIPLES

a. *Overview*

Except for cold weather operations, the Cuban Armed Forces are capable of undertaking all types of conventional operations. They have no known stockpiles of nuclear weapons. They have a very limited capability to employ nuclear weapons (principally through the FROG-5) and a limited capability to employ chemical and biological weapons. Although there has been no evidence that the Cubans would actually employ nuclear, biological and chemical weapons, they practice conducting exercises in a simulated NBC environment.

Until the large-scale involvement in Africa, Cuban military doctrine focused on defending the island from a large-scale enemy invasion. The involvement in Africa, however, has created an emphasis on offensive operations.

b. *General Principles*

(1) *Offensive Action*

Offensive actions are stressed as the principle method of destroying the enemy, and of seizing the initiative.

(2) *Exploitation of Fire Power*

The Cuban military stresses the importance of artillery in combat operations. Regimental and divisional commanders place heavy emphasis on artillery preparations.

(3) *Surprise*

The Cubans stress surprise, which is achieved by secrecy of planning, camouflage, and deception. Additionally, the Cuban Army stresses the use of flanking maneuvers.

(4) *Security*

The Cubans would employ active and passive means to frustrate enemy intelligence efforts while discovering and monitoring enemy intentions and capabilities. Cuban forces are employed in depth and all combat elements are integrated to enhance the overall security effort.

(5) *Reconnaissance*

Reconnaissance forces are deployed well forward to determine enemy intentions, disposition and force composition. Aircraft, airborne reconnaissance parties, and engineer reconnaissance patrols are also employed.

c. *Special Techniques*

(1) *Electronic Warfare*

The Cubans have limited direction finding (DF), intercept and jamming capabilities. They can be expected to employ some DF equipment and



The DDA-53C Decontamination Apparatus mounted on a GAZ-66 Truck. It is used to steam decontaminate clothing and small items of equipment and also provides hot water for showers and personnel decontamination.

jamming devices. They probably will implement deception measures such as establishing dummy radio nets.

(2) *Chemical Warfare*

The Cubans have the capability to employ chemical agents, and they conduct training under simulated chemical warfare conditions for all the troops. Special chemical defense units, responsible for decontamination, are organic at regimental level and above. In addition, each division has a chemical defense company with the following capabilities: personnel decontamination, reconnaissance and observation, and smoke generating and flamethrowing.



The vehicle on the left probably is an ARS-12 Decontamination Apparatus, which is used to decontaminate vehicles, weapons, equipment, terrain and roads. It can also be used to fight fires and provide cold showers for personnel.

(3) *Nuclear Warfare*

The Cubans are not believed to have any nuclear weapons, although some weapons like the FROG could be armed with a nuclear warhead. Between 1975 and 1977, Cuba increased military and civil defense training under simulated nuclear conditions in order to reduce the effects of nuclear weapons.

3. RECONNAISSANCE

The Cuban military is inferior to Western and Soviet forces in certain technological support aspects such as air, fire control, reconnaissance and surveillance equipment. The principal types of reconnaissance are discussed



Two BRDM Armored Reconnaissance Vehicles armed with the 14.5-mm KPVT machinegun.



A motorcycle unit on reconnaissance. The sidecar is armed with a machinegun.

below. Figure 10 summarizes the ranges at which some of the reconnaissance elements operate.

a. *Air Reconnaissance*

Air reconnaissance is an important source of combat intelligence. Pilots can report targets directly by radio to ground forces. The Cuban Air Force probably has tactical photographic and infrared capabilities.

b. *Patrols*

The Cubans can be expected to patrol aggressively, with both vehicular and foot patrols. In addition, the Cubans would not hesitate to employ soldiers in civilian clothing or enemy uniforms for reconnaissance purposes. When operating in Cuba, the military would make extensive use of the informant net which MININT has developed throughout the island. Reconnaissance activities will increase prior to offensive and defensive actions and will be directed all along the front to discover weak points. The activities may include: feints, to induce the enemy to disclose his positions, and raids in strength, to test enemy reactions and to take prisoners.

c. *Observation Posts*

In combat situations, every unit is expected to establish observation posts (OPs). These posts will have wire communications. Division OPs may operate up to 5 kilometers forward of the Forward Edge of the Battle Area (FEBA).

d. *Motorized Reconnaissance*

Cuban units, regiments through armies, have organic motorized reconnaissance organizations equipped with a variety of vehicles from motorcycles to light tanks, depending on their mission. Elements from these units operate up to 20 kilometers from the main body. There are also special reconnaissance elements for engineer, artillery and chemical units.

e. *Artillery Target Acquisition*

Army, corps and division artillery target acquisition elements probably contain counterbattery radars, radio direction finding equipment and sound-ranging devices. Normal reaction time to effectively engage targets located by visual means would be about 30 minutes.

4. FIREPOWER

a. *Artillery*

(1) *Allocation*

MINFAR headquarters probably will allocate FROG and SCC-2a SALISH battalions to the armies or corps, although it will retain direct control

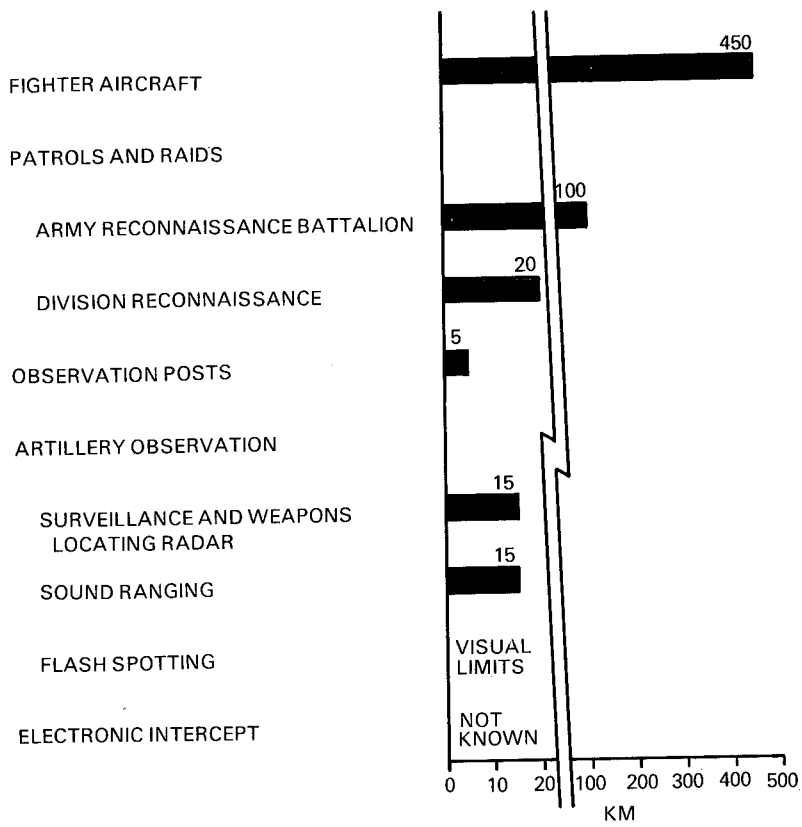

Figure 10. Effective Range of Cuban Reconnaissance Means.

over some elements. Army and corps artillery units will be allocated to support maneuver units as required. Artillery will be placed in direct support of first echelon elements. Second echelon units will not be allocated direct artillery support until they are committed.

(2) *Control*

Formal fire plans are detailed and meticulous, and control is retained at the highest practical headquarters. On completion of initial fires, the control of the artillery units is decentralized.



Plotting fire for artillery pieces. Like the Soviets, the Cubans stress massed artillery under all conditions.

Artillery is organized into temporary tactical groups to provide the fire support required by the tactical situation. These groups are:

- *Regimental Artillery Groups (RAGs)*, in which existing regimental artillery units are augmented by division, corps and/or army artillery assets. A RAG is normally composed of at least two artillery battalions. The RAGs support maneuver battalions or regiments and are located well forward.
- *Division Artillery Groups (DAGs)*, in which division artillery units are augmented by corps and/or army artillery assets. A DAG is normally composed of several artillery battalions. The DAGs, usually composed of long-range artillery and multiple rocket launchers, are located further back than the RAGs and support either regiments or divisions.

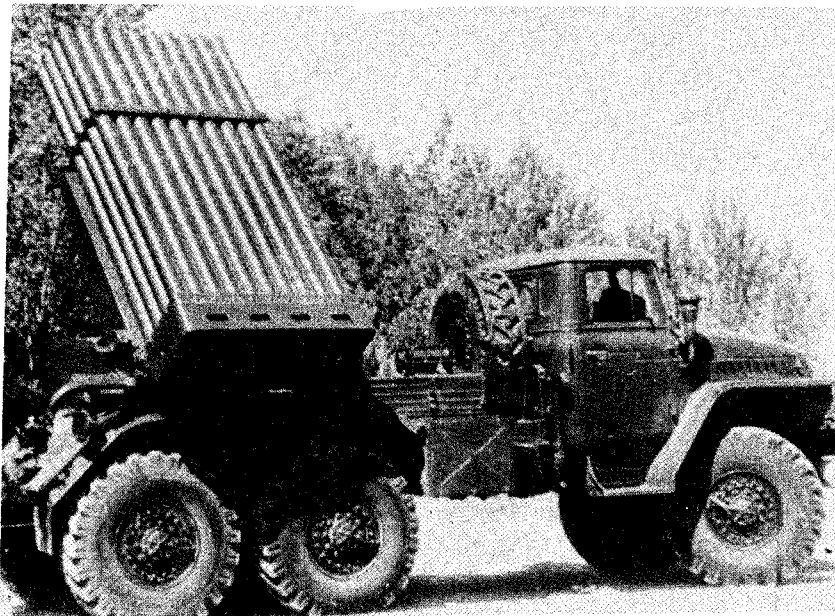

The 122-mm Rocket Launcher (40 round) BM-21 mounted on a URAL-375 truck. This weapon is at division level and higher and can be organized in Division Artillery Groups (DAGs). The Cubans deployed this weapon in Africa.

Six artillery pieces comprise an artillery battery and three artillery batteries comprise a battalion. Each battery is normally positioned in a line along 200 to 300 meters of frontage and the batteries are deployed in a triangle with about 1 kilometer separating each battery.

While artillery communications are adequate, a radio link is seldom established with the supporting unit and the Cubans usually depend instead on the collocation of the artillery commander with the supported commander. Forward observers are deployed well ahead with the front-line battalions.

(3) Deployment

Cuban field and antitank guns, towed by wheeled and tracked prime movers, have a good long-range performance. If warranted by a tank threat, organic artillery will be employed in the antitank role. High velocity guns are equipped with armor-piercing ammunition; lower velocity weapons, with SHAPÉ charge.

b. Tank and Antitank Fire

Antitank fire planning is detailed and coordinated at the highest possible level. Flanks and tank approaches are covered by mutually supporting antitank weapons in depth.

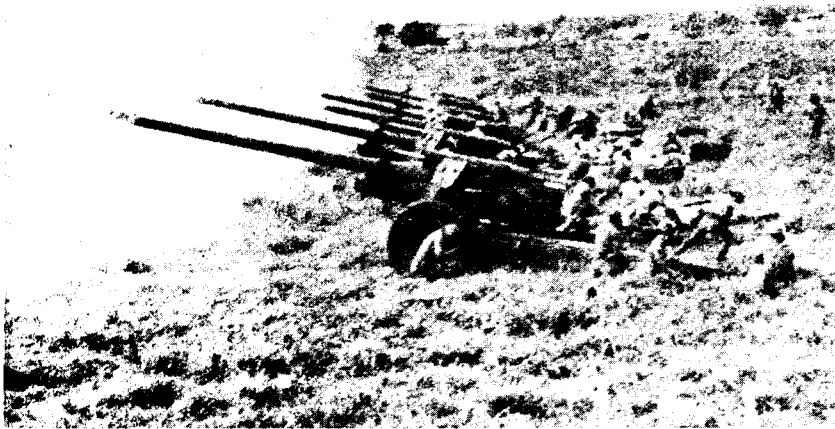

A battery of six 100-mm M1955 Field Guns open fire.

Regiment and division antitank reserves are task-organized for both the offense and the defense. These reserves are normally made up of both guns and tanks and in defensive situations frequently include engineers for obstacle support. The role of an antitank reserve is to deploy rapidly to meet tank threats.

In addition to RPG-7 40-mm antitank grenade launchers, some battalions have SNAPPER and SAGGER antitank guided weapons (ATGW), which are usually mounted on BRDMs.

c. Tactical Air Support

Cuban tactical air support to ground forces, compared with Western and Soviet armies, is limited in quantity and quality but has received increased emphasis during recent years.

(1) Close Air Support

Cuba's close air support aircraft inventory includes both fighter aircraft and armed helicopters. Fighter aircraft normally operate in pairs or in multiples of pairs. Attacks can be made with conventional bombs, napalm, cannon or rockets. Aircraft approach the target at high speeds, and at a readily recognized identification point, the pilot normally will pull up to identify the target. The pilot will then execute a dive, which can be steep or shallow, to release his load.

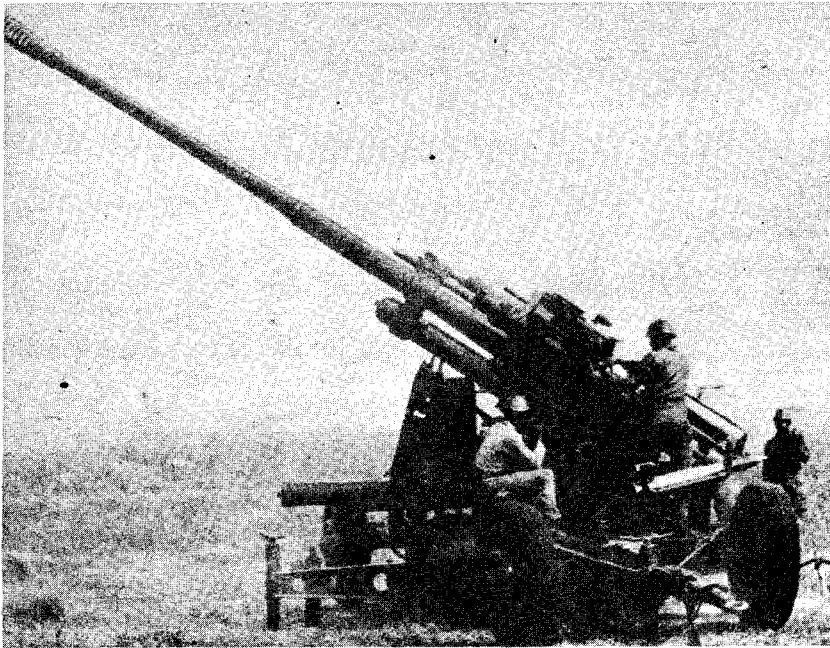

A 130-mm M-46 Field Gun.

Although a pull up at a recognized point is normal procedure, low-level rocket attacks cannot be discounted.

At night, attacks can be made with the assistance of flares dropped by supporting aircraft. Approaches to the target and weapon release would then be made at much higher altitude than during daylight.

(2) Allocation and Control of Close Air Support

The army or corps headquarters will normally retain control of allocated close air sorties, assigning them as necessary. Air liaison officers and forward air controllers are deployed with divisions to coordinate the air support of ground operations. Additionally, helicopters can be used in a forward air control role. Information concerning the communications links between the airplanes and controlling elements, and regarding specific procedures for approving or disapproving requests, is not available.

d. Air Defense

Air defense missions are similar to those assigned to US and Soviet air defense units and include protecting headquarters elements, supply and communications facilities, and major installations.



The Anti-aircraft Fire Control Director PUAZO-6 with the D-49 Rangefinder, which is a World War II generation sighting mechanism used by Cuban anti-air defense units.

Cuba has a target acquisition and warning system which provides air defense units with targets and combat units with early warning. The system, however, is based primarily on older Soviet radars which would have a limited effectiveness against a modern air force.

Air defense officers at regiment and above are responsible for air defense planning. The chief and his men are under the administrative control of DAAFAR for personnel, weapons and training matters, although they are under the operational control of the ground unit commander for deployment and combat control.

Cuba has a wide variety of air defense weapons, which are described in appendix M. In addition to the towed and self-propelled guns, it has the SA-2 GUIDELINE, SA-3 GOA (illustrated in appendix R) and SA-7 GRAIL (illustrated in appendix M) surface-to-air missiles. Furthermore, the Cuban Army has numerous machineguns and other small arms which would be used in an air defense role.

5. PRINCIPLES OF COMBAT

a. *General*

Cuban tactics are based on fire and maneuver. The Cuban Army is predominantly an infantry force and its tactics are designed to exploit the capabilities of the infantry. However, the Cubans have upgraded their armor and mechanized capabilities since 1970 with the acquisition of hundreds of tanks, armored reconnaissance vehicles and armored personnel carriers.



T-54/55 tanks are the primary tanks in the Cuban arsenal.



The T-34 tank has an 85-mm gun. Although it is being replaced by the T-54/55 and T-62, it is still a respectable combat vehicle.

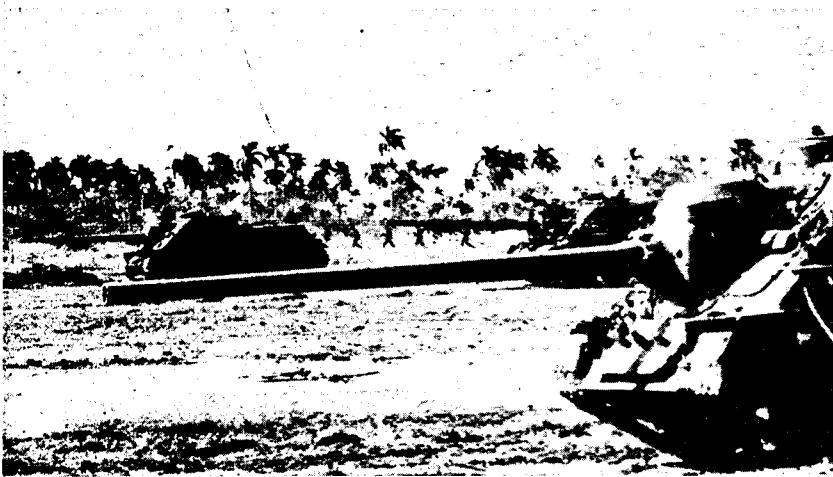

Three SU-100 Assault Guns. These are frequently found in tank units.

Once an attack is launched, the Cubans will try to maintain the momentum until their objectives are seized. The Cubans try to retain freedom of maneuver, and emphasize attacking in depth. They are quick to take advantage of a penetration of their opponent's forward defenses. The Cuban Army also stresses infiltration as a means of gaining a tactical advantage.

Although the Cuban-adopted Soviet doctrine strongly emphasizes night warfare, the average Cuban soldier has had much less training in night warfare than his Soviet counterpart. However, in confronting an enemy which has superior air power, the Cubans most likely will adopt night maneuvers to minimize losses from air attacks. Most of the vehicles in the Cuban inventory are equipped with night-driving devices.

b. *Offense*

In the offense, Cuban units are assigned the following objectives:

- An initial objective, which should be taken by the first echelon.
- A subsequent objective, which may require commitment of the second echelon and which normally coincides with the initial objective of the next higher headquarters.

The Cubans stress detailed planning with emphasis on:

- Rapid and bold offensive action.
- Maintaining the momentum.

c. Defense

In the Cuban tactical doctrine, the defense is undertaken as an interim measure during which preparations are made for resuming the offense. The basic form of the defense is the area defense in which major commanders are ordered to defend within a certain area until relieved by higher authority. It is organized in depth and designed to deny key terrain to the enemy, to halt his attack, and to inflict significant losses. Forward units engage the enemy decisively and hold at all costs with no thought of withdrawing to successive defensive positions.

Any Cuban citizen within an area should be considered supportive of the Cuban Government.

d. Movements

Generally, formations march in tactical order ready for combat. The interval between vehicles is up to 50 meters during road movement and 100 meters during tactical cross-country movement. Since the Cuban Army has increased its mechanized and motorized capabilities, it has placed more emphasis on road movements.

With only limited air cover available, the Cubans probably would stress vehicular movement during periods of darkness or reduced visibility in small columns varying in size to about 25 vehicles. Movements are strictly controlled, with emphasis placed on convoy discipline, and march tables are closely followed. To assist the commander, all units have personnel trained in traffic control duties.

Section C—Offensive Operations

1. MANEUVER FORMS AND OFFENSIVE ACTIONS

The fundamental Cuban military doctrine, like that of the Soviet Union, is that victory can be won only by offensive action. Cuban doctrine calls for numerical and firepower superiority. A ratio of at least 3:1 is considered necessary for offensive operations, and the Cubans are quite prepared to reduce their strength in other sectors to achieve that ratio.

a. Basic Forms of Maneuver

Cuban offensive doctrine is based on two principal maneuver forms: frontal attacks and envelopments (figure 11). The Cubans will employ the frontal attacks to achieve a penetration of an enemy line which does not present an assailable flank. When possible, the Cuban Army will attempt to envelop its enemy. The Cubans stress both a close envelopment, which is a shallow maneuver conducted against the enemy flanks, and a deep envelopment, or turning movement, which is directed at the enemy's rear areas. The Cubans will combine the envelopment with a frontal attack, using the frontal attack to fix the enemy's forces.

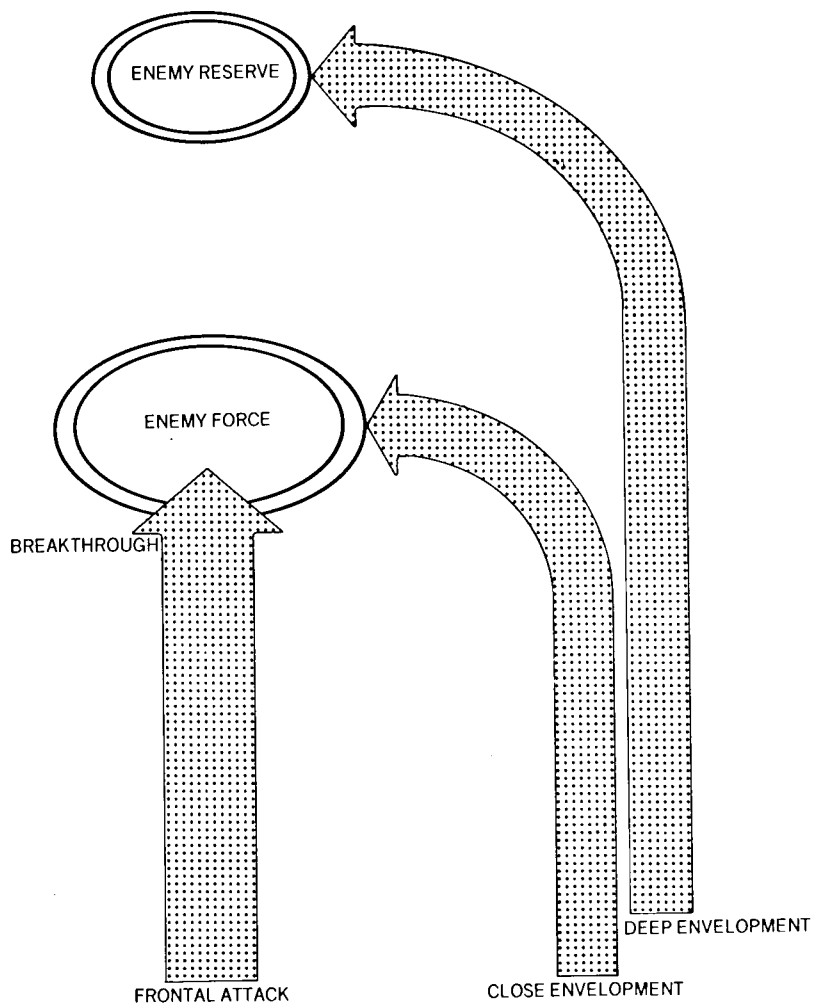

Figure 11. Basic Maneuver Forms.

b. *Movement to Contact*

Movement to contact is a tactical march conducted in a theater of operations preliminary to combat in order to place troops in a position to close with the enemy for combat. The movement to contact terminates when enemy forces are confronted.

c. *Types of Offensive Operations*

The Cubans classify offensive operations into three major types: the *meeting engagement*, the *breakthrough*, and the *pursuit*. The meeting engagement is the combat action which occurs when opposing columns rapidly advance and collide with each other.* The Cubans expect that the *meeting engagement* will be the most common type of combat action. It can occur during several types of combat activities: during a march, after a breakthrough operation as penetrating forces encounter enemy reserves or second echelon troops brought forward to fill gaps, or during pursuit operations when pursuing forces come into contact with reinforcing or counterattacking enemy units.

Through the use of aggressive and detailed reconnaissance, combined with rapid deployment and decisive action by the main body, the Cubans expect to be able to surprise an enemy before it has an opportunity to organize adequately its forces for combat. Throughout a meeting engagement, the situation remains fluid and fast-moving, with advance elements of both sides attempting to seize positions which facilitate the deployment of main force units. Figure 12 illustrates the initial stages of a meeting engagement as conducted by a reinforced mechanized infantry battalion.

The *breakthrough* (figure 13) is the desired result of an attack on either hastily or deliberately prepared enemy positions, achieved by bringing superior forces and firepower to bear against selected sections of the enemy line. The Cuban doctrine usually specifies two echelons in the attacking force. About two-thirds of the total strength is assigned to the first echelon. The main attacking force has the responsibility for achieving the primary objectives. The second echelon, which has no US Army equivalent, follows the first and focuses on the "subsequent" objective or other designated tasks. Some commanders may withhold a small reserve for flexibility in meeting unanticipated requirements or mopping up action. Two echelons are normally employed at regiment or above. Battalions operate as a single echelon.

The *pursuit* (figure 14) is the logical continuation of a successful offensive action. It will be initiated when the Cubans believe that the enemy has either lost his ability to operate effectively and/or is attempting to disengage. Its purpose is the destruction of enemy forces. The Cuban Army can be expected to commit all available units to maintain contact and pressure. Usually, the Cubans will send two forces, one to maintain contact with the retreating enemy, and the

*AR 310-25, *Dictionary of United States Army Terms*, gives a broader definition of a meeting engagement by stating the engagement can occur when the enemy force is static.

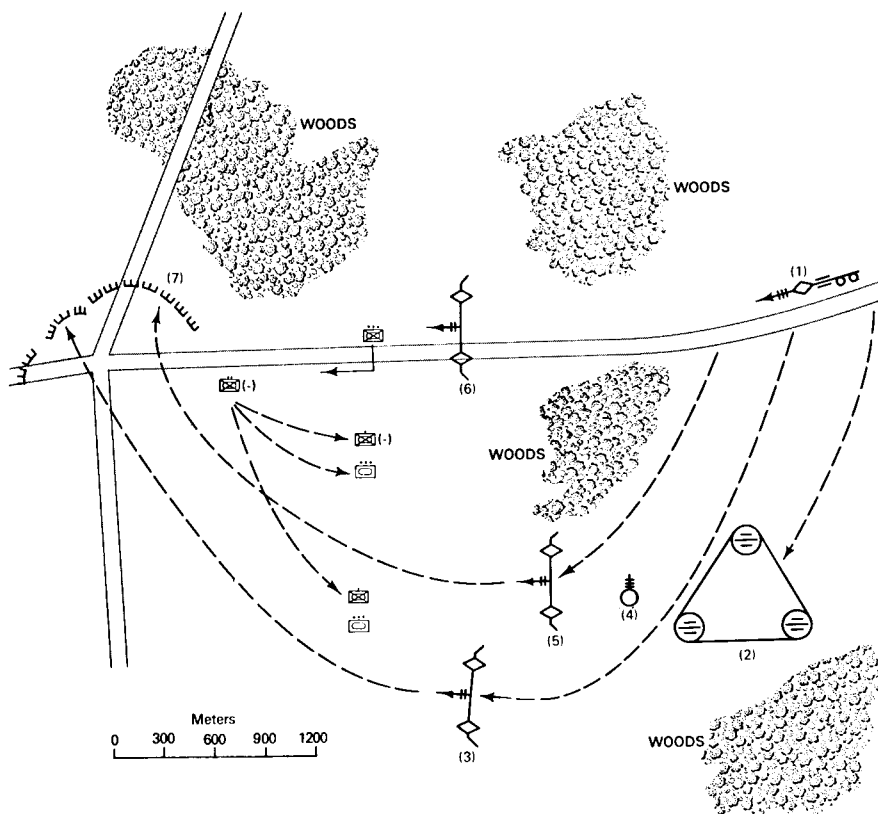

KEY

1. A Cuban mechanized infantry battalion (MIB), reinforced with tanks and artillery, acts as the advance guard of the regiment.
2. Second artillery battalion (in deployed position).
3. Third mechanized infantry company reinforced with a tank platoon.
4. Battalion commander.
5. Second mechanized infantry company reinforced with a tank platoon.
6. First mechanized infantry company with an attached tank platoon acts as the advance guard.
7. Defensive positions.

Figure 12. A Reinforced Mechanized Infantry Battalion in the Initial Stages of a Meeting Engagement.

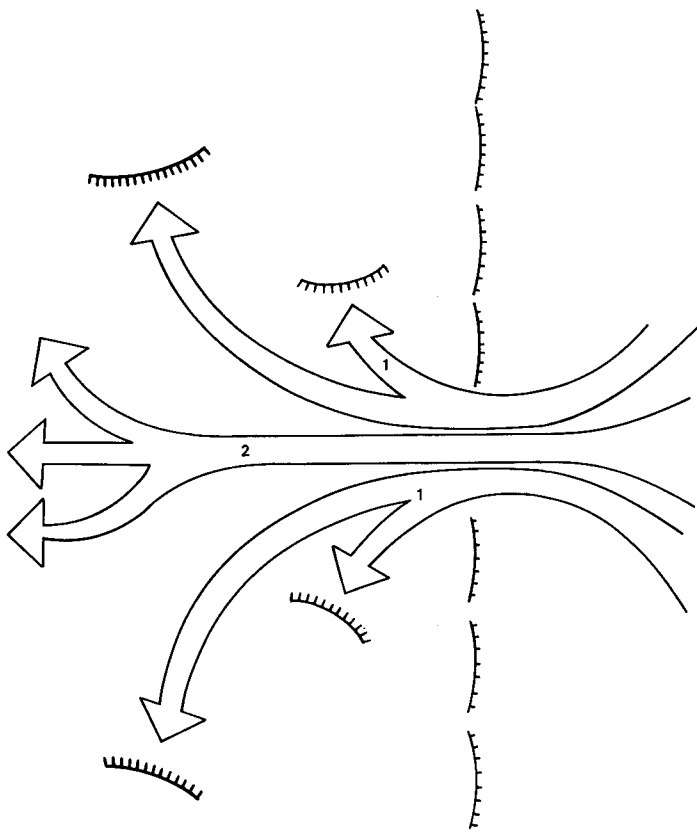

KEY

1. First echelon forces achieve a breakthrough and hold the shoulders of the penetration for exploitation by second echelon forces.
2. Second echelon forces exploit the penetration.

Figure 13. The Breakthrough.

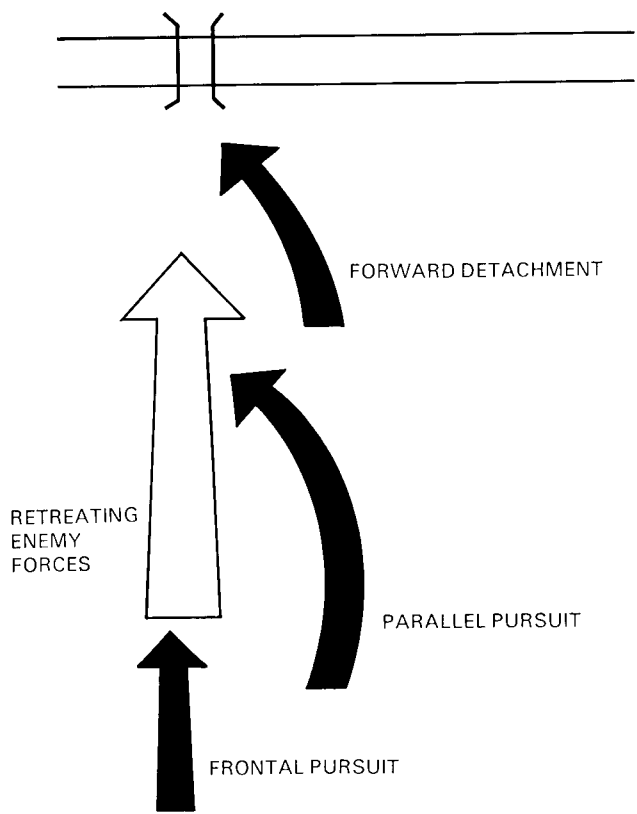

Figure 14. The Pursuit.

other to seize key lines of communications (such as bridges) that the retreating enemy needs to cross, or to attack the fleeing forces from the flanks, or to establish blocking positions.

In the Cuban view, defense against the counterattack is an offensive requirement. Therefore, the Cubans stress aggressive reconnaissance, air defense and antitank defense to identify and neutralize counterattacks. Plans to defend a captured objective are made and carried out with the same urgency given to seizure of the objective in offensive operations. Because the Cubans anticipate long, exposed flanks in offensive operations, they emphasize flank security. In spite of this emphasis, they are vulnerable to counterattack on their flanks.

2. FORMATION AND SCHEMES OF MANEUVER FOR OFFENSIVE TACTICAL SITUATIONS

a. Formation

Formations for mechanized infantry platoons and companies as well as tank platoons, which are used in the forms of maneuver and types of offensive actions discussed in section C-1 above, are illustrated in figures 15 through 20. The platoons and companies attack, mounted or dismounted, on line. Squad fire and maneuver is rare. Normally, the platoon leader is positioned to the rear of his center squad.

b. Schemes of Maneuver for Battalions and Below for Offensive Tactical Situations

Some tactical schemes of maneuver for battalion-size and smaller mechanized infantry and tank units are illustrated in figures 21 through 24. These are used in the forms of maneuver and types of offensive action discussed in section C-1 above.

3. FRONTAGES

Probable typical yardsticks for the corps and subordinate units which are composed mostly of infantry units in conventional offensive operations are shown in figure 25.

Frontages, depth of objectives and rear boundaries from FEBAs (Forward Edge of the Battle Area) for armored and mechanized infantry divisions, regiments and battalions in conventional operations probably would be about 30 to 40 percent more than those for infantry units illustrated in figure 25. In nuclear operations, the distances for all units probably would be double those given in the figure. Figure 26 portrays the attack frontage for an infantry division in conventional operations.

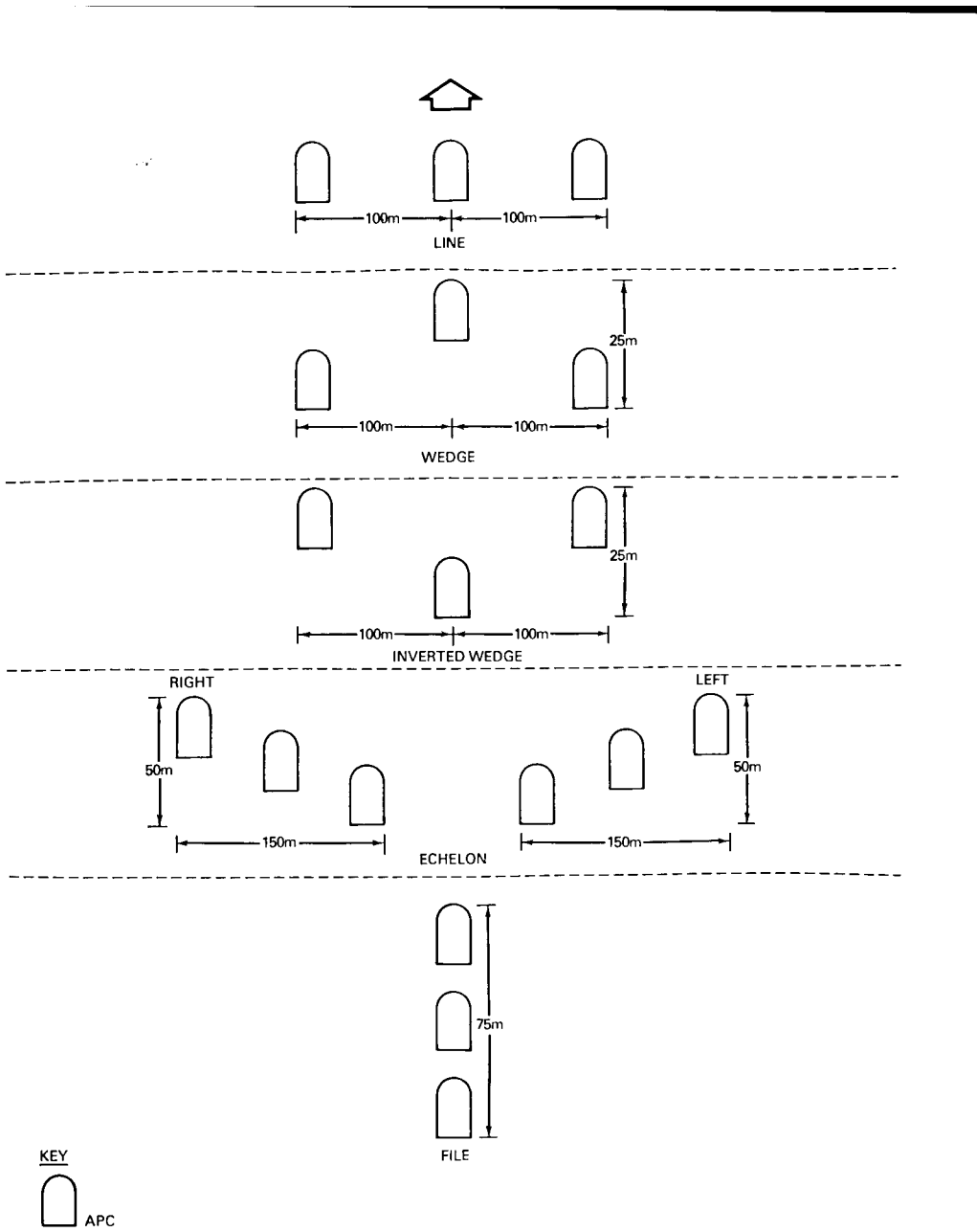

In mounted formations, the platoon and squad leaders will position themselves in the best locations to control their units, which usually is in the center of the unit.

Figure 15. Mounted Mechanized Infantry Platoon Formations.

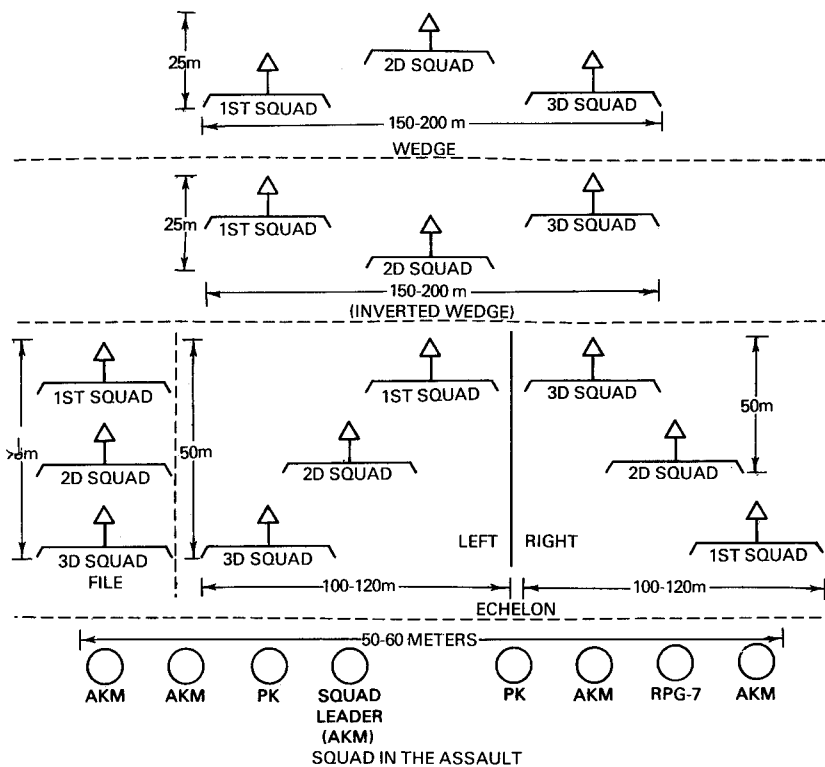

1. In dismounted formations, the squad and platoon leaders will position themselves in the best locations to control their units, which usually is behind the center unit.
2. APCs usually follow their squads and support them by fire at a distance of 100 to 200 meters.

KEY

AKM 7.62-mm assault gun
 PK 7.62-mm machinegun
 RPG-7 40-mm rocket launcher

Figure 16. Dismounted Mechanized Infantry Platoon Formations.

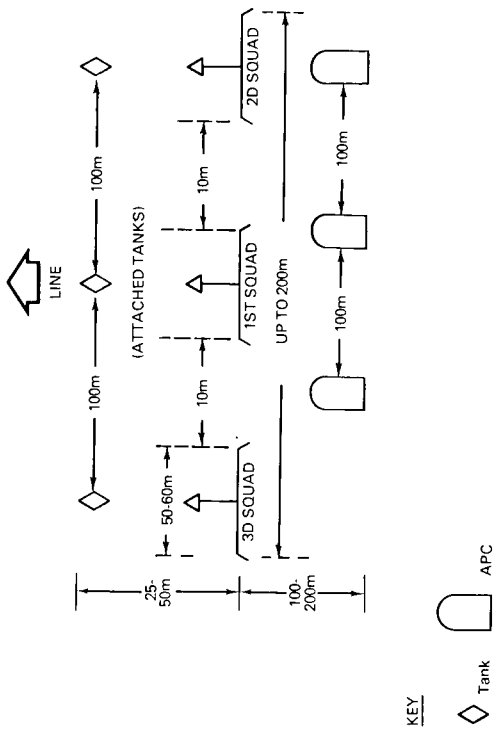

1. In dismounted formations, the squad and platoon leaders will position themselves in the best locations to control their units.
2. APCs usually follow their squads and support them by fire at a distance of 100 to 200 meters.

Figure 17. Dismounted Mechanized Infantry Platoon Supporting a Tank Platoon Attack.

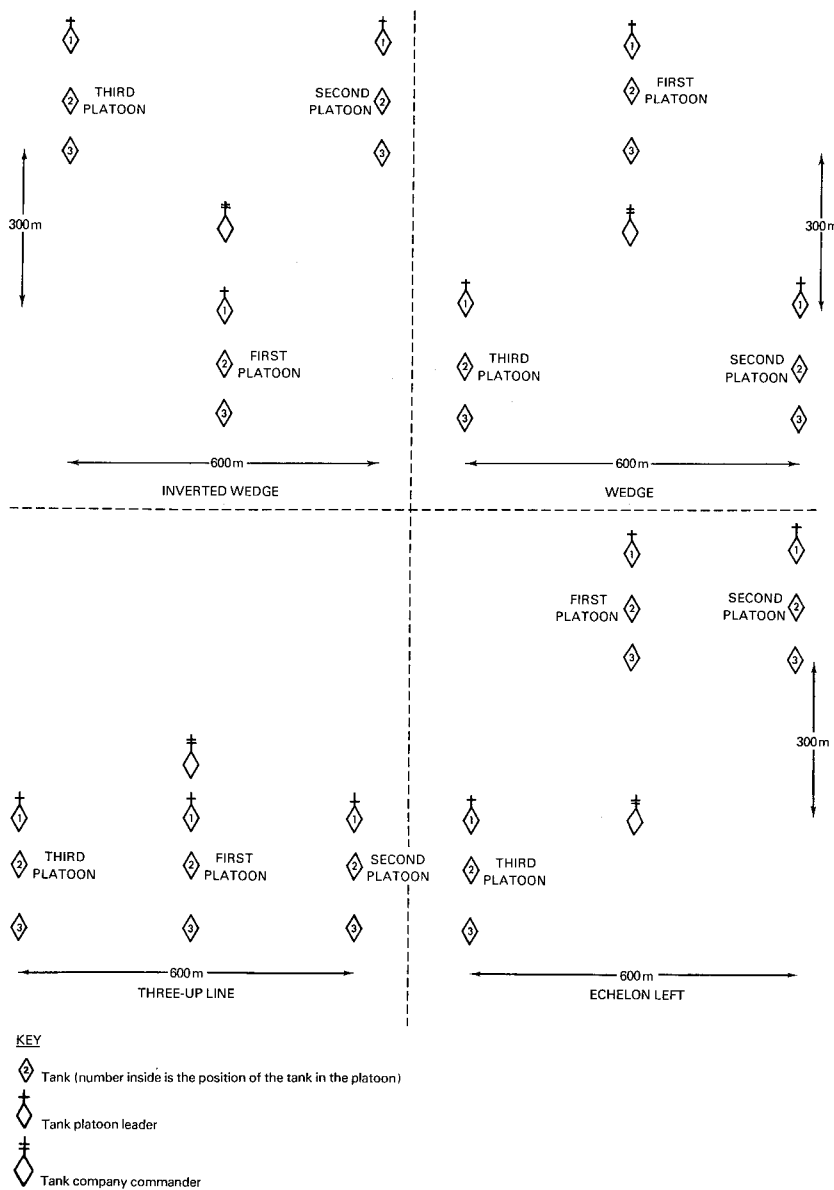

These formations may be used in combat if the Cuban units encounter weak resistance.

Figure 18. Approach March Formations for the Tank Company.

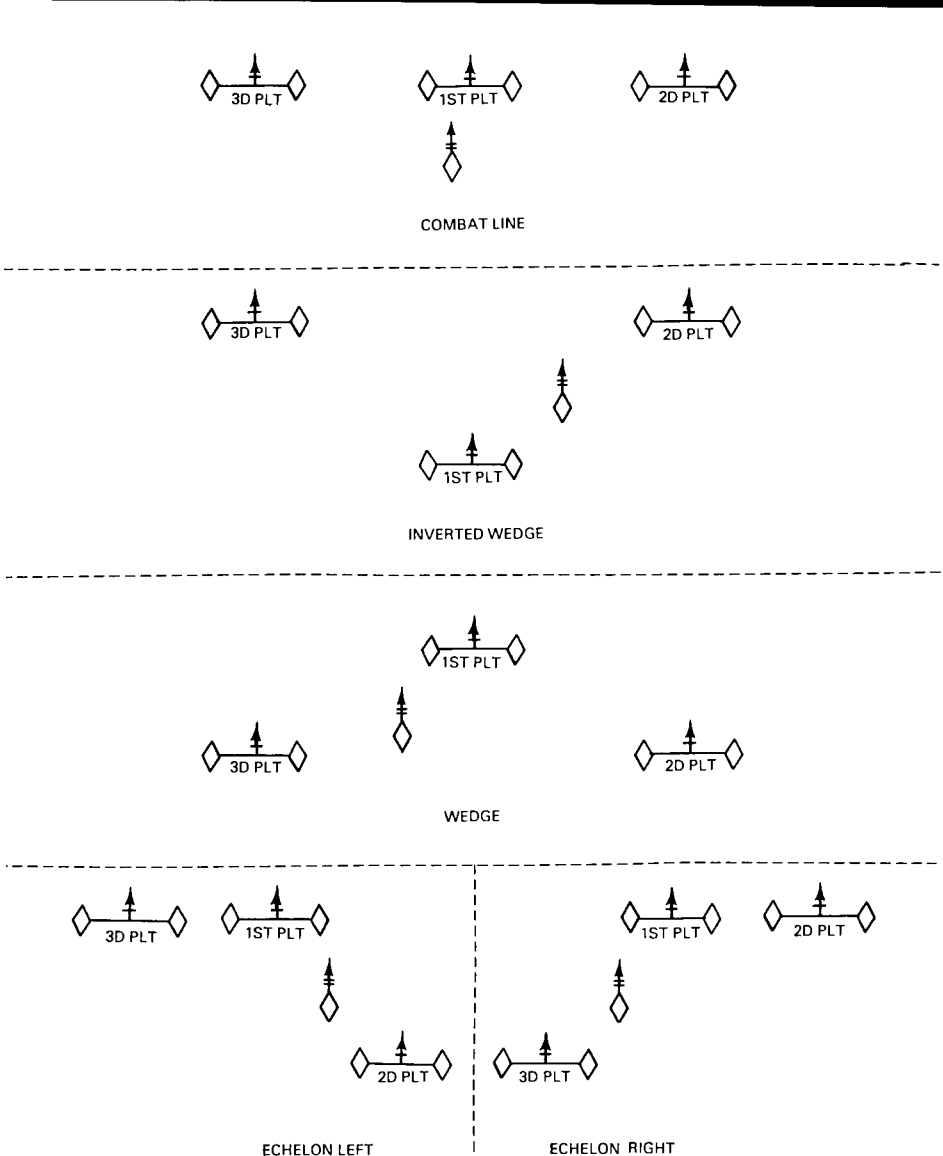

KEY

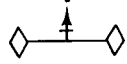
-  Company commander
-  Tank platoon moving abreast in combat formation.

These formations will be used when the Cubans encounter strongly defended positions.

Figure 19. Combat Formations for the Tank Company.

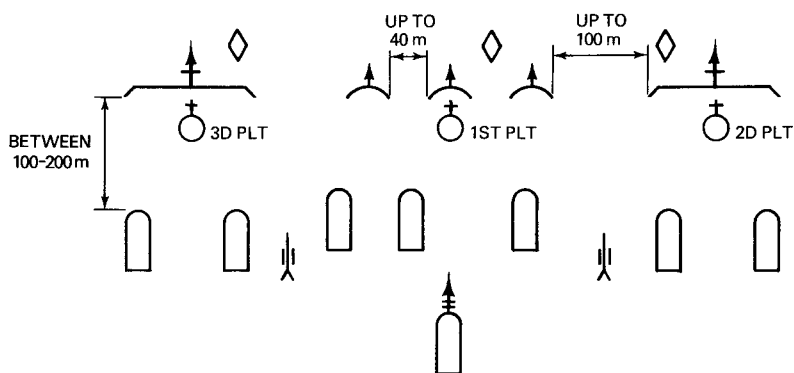
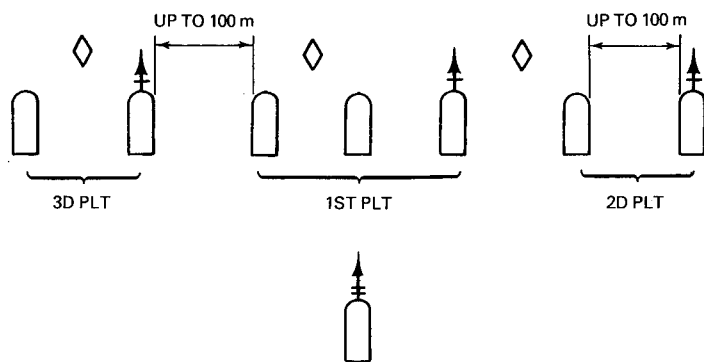

KEY









-  Tank
-  APC
-  Mounted Platoon Leader
-  Company Commander
-  Platoon in Attack Formation (dismounted)
-  Squad (dismounted)
-  Dismounted Platoon Leader
-  Antitank Weapon

Figure 20. Mounted and Dismounted Combat Formations for a Mechanized Infantry Company on Line in the Attack.

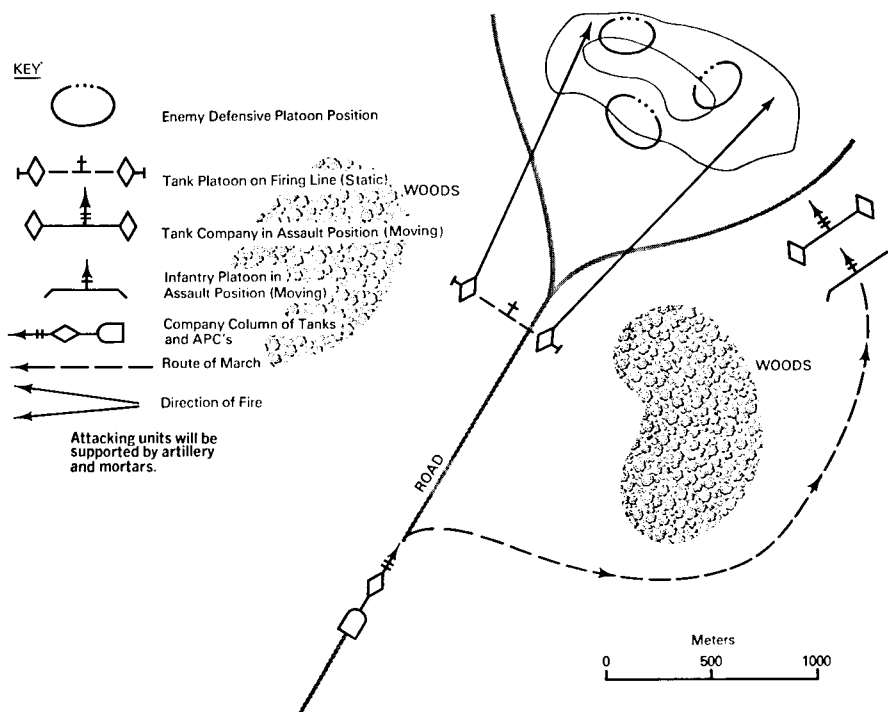

Figure 21. Enveloping Attack by Reinforced Tank Company.

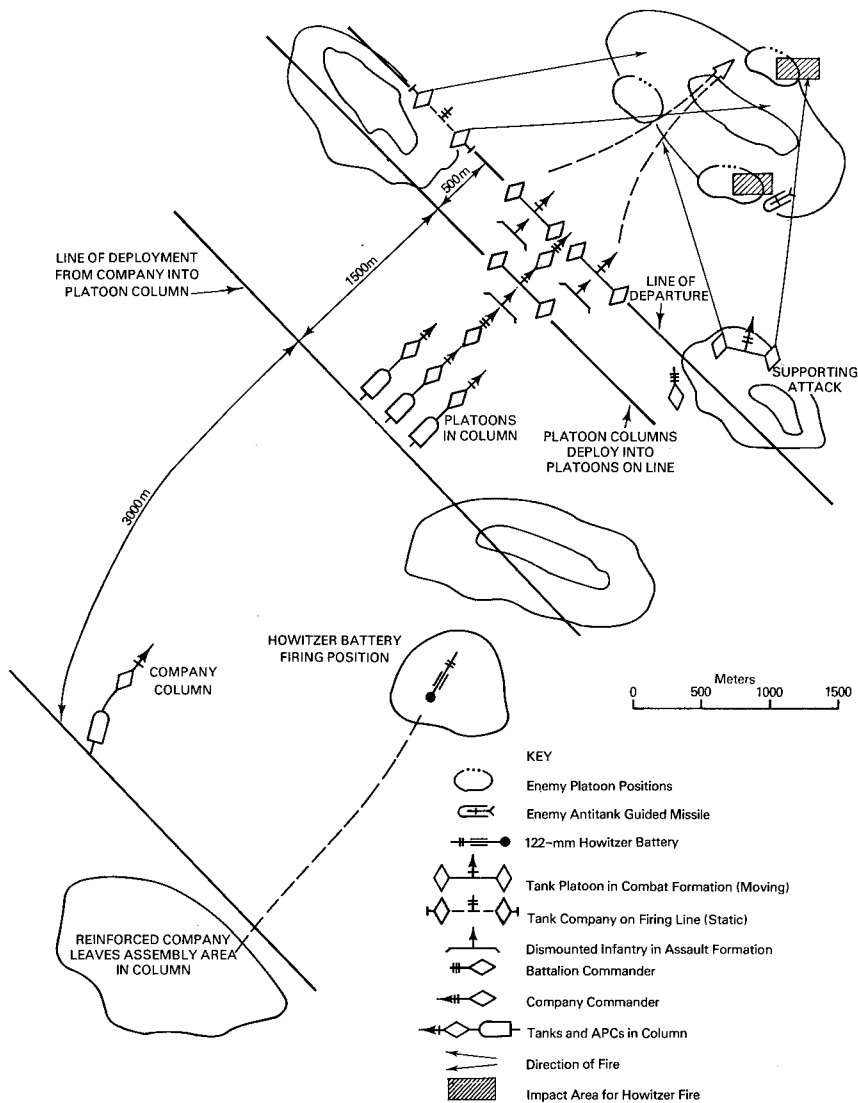

Figure 22. Attack from an Assembly Area by a Reinforced Tank Company Which is Part of a Tank Battalion.

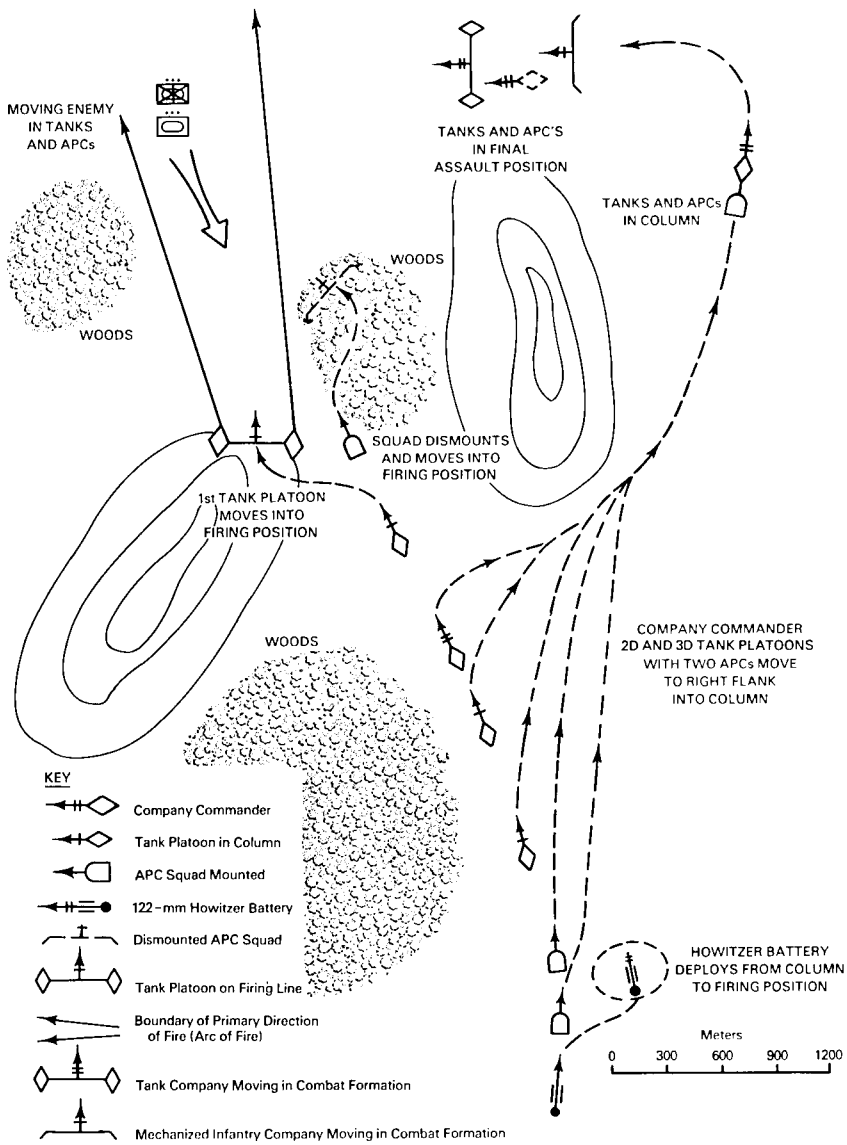

Figure 23. Assault Formations for a Reinforced Tank Company.

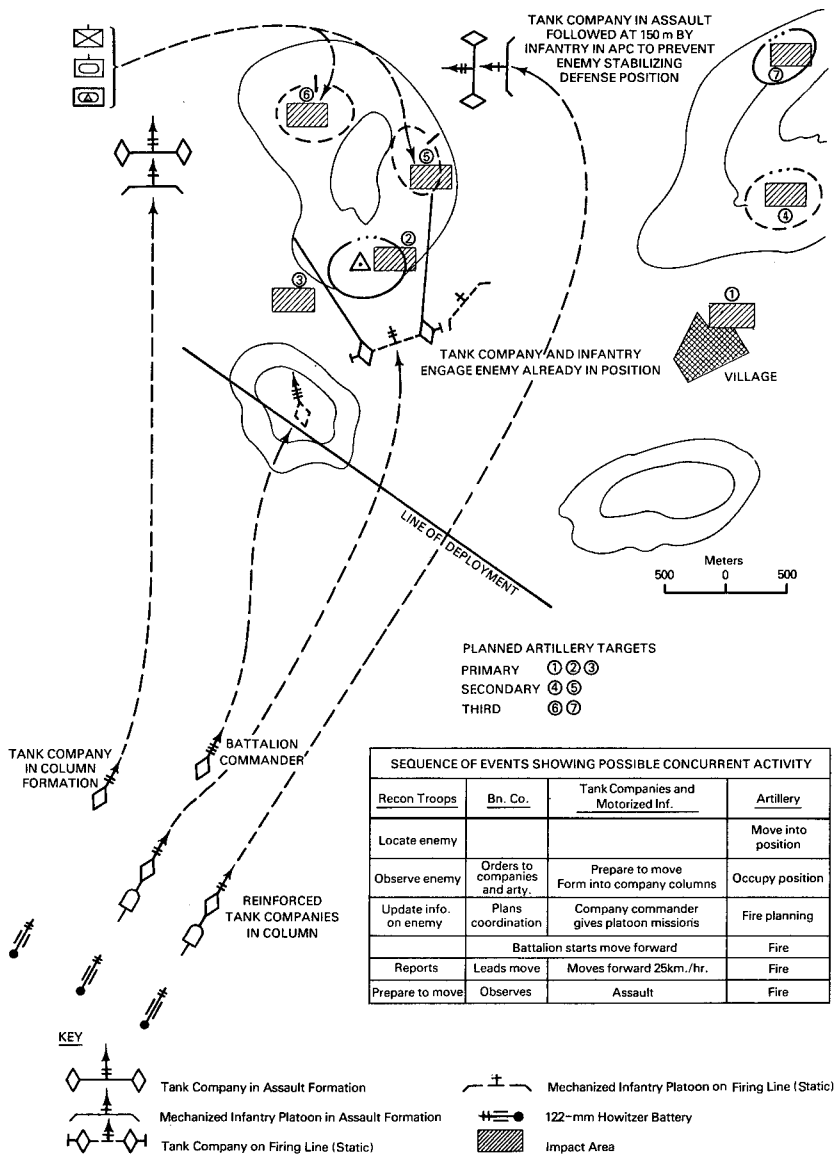

Figure 24. Breakthrough of the Hasty Defensive Position by a Tank Battalion.

4. DIVISIONS IN OFFENSIVE OPERATIONS

a. Movement to Contact

The basic order of march of a Cuban infantry division in a movement to contact is presented in figure 27.

In a movement to contact, tanks and artillery are usually forward and antiaircraft weapons are distributed throughout the columns. Mechanized and motorized reconnaissance elements from division and regiment reconnaissance units will be employed on the routes of advance. The division elements may be employed up to 45 kilometers from the advance guard. The regimental reconnaissance patrols may be deployed as far as 15 kilometers from the advance guard, and are responsible for maintaining contact with the division reconnaissance elements.

	Corps*	Inf. Div.	Inf. Reg.	Inf. Bn.	Company	Platoon
Frontages						
Sector of responsibility	12-30 km	4-8 km	2-4 km	1-2 km	300-500 m	—
Attack frontage	4-8 km	2-3 km	1.5 km	500-750 m	150-200 m	50-100 m
Depth of Objective						
Initial	6-12 km	2-4 km	1-2 km	1/2-1 km	—	—
Subsequent	25-30 km	6-12 km	2-4 km	1-2 km	—	—
Rear Boundaries from FEBA	20 km	12 km	4 km	2 km	—	—

*A corps would have at least 3 infantry divisions.

Figure 25. Frontages and Depths for Infantry Units in Conventional Offensive Operations.

The division usually moves in two or three parallel columns. Each leading regiment is responsible for its own security and has a reinforced infantry battalion as an advance guard.

The division headquarters will be at the head of the main body. Armor elements will be well forward with some artillery and air defense elements. The forward, flank and rear security is the responsibility of the division commander who deploys his combat and combat support elements. Each element is responsible for its own flanks. The composition and size of the flank security will depend on the enemy threat. When possible, flank security is mounted and moves along parallel routes, approximately 10 kilometers from the main body, to give early warning of enemy intentions, to prevent direct fire on the main force, and to give the commander freedom of movement.

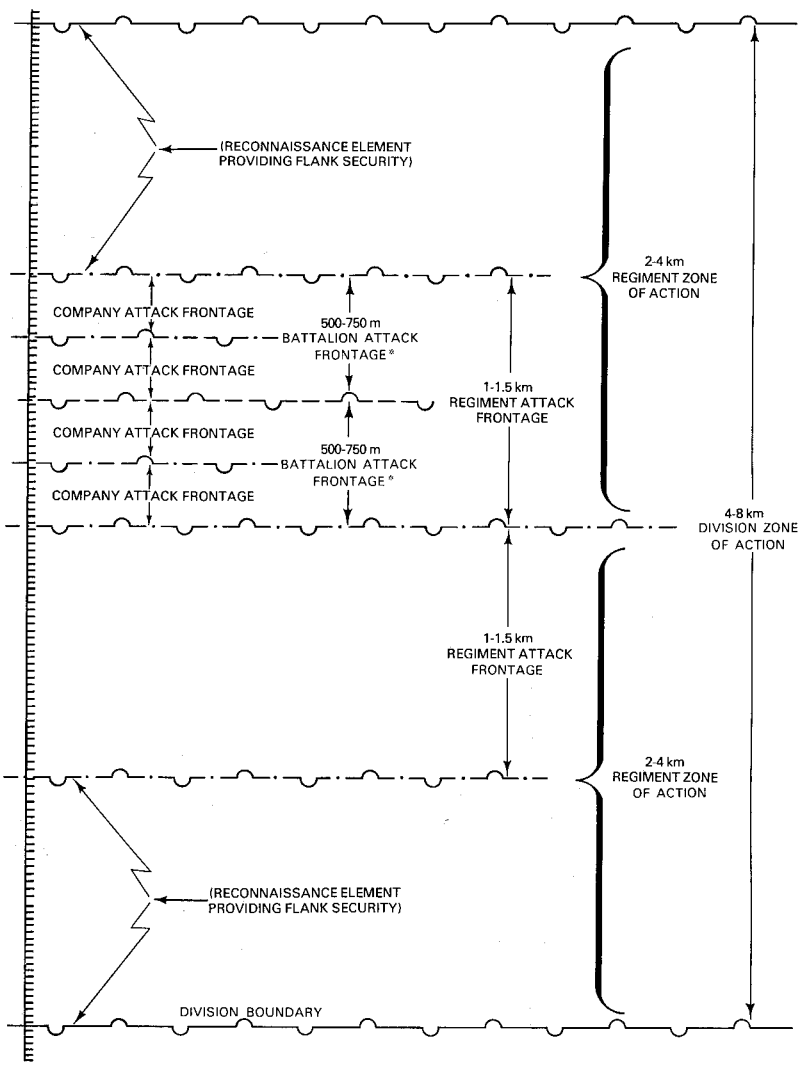





- KEY**
-  Company Boundary
 -  Battalion Boundary
 -  Regiment Boundary
 -  Division Boundary
 -  Direction of Attack. Two Regiments are on Line.
 - *Some battalions may have more companies on line.

Figure 26. Infantry Division Concentration for the Attack.



KEY

- 1 Division and Regiment Reconnaissance
- 2 Forward Detachment*
- 3 Advance Guard**
- 4 Flank Security
- 5 Main Body +
- 6 Rear Services
- 7 Rear Security

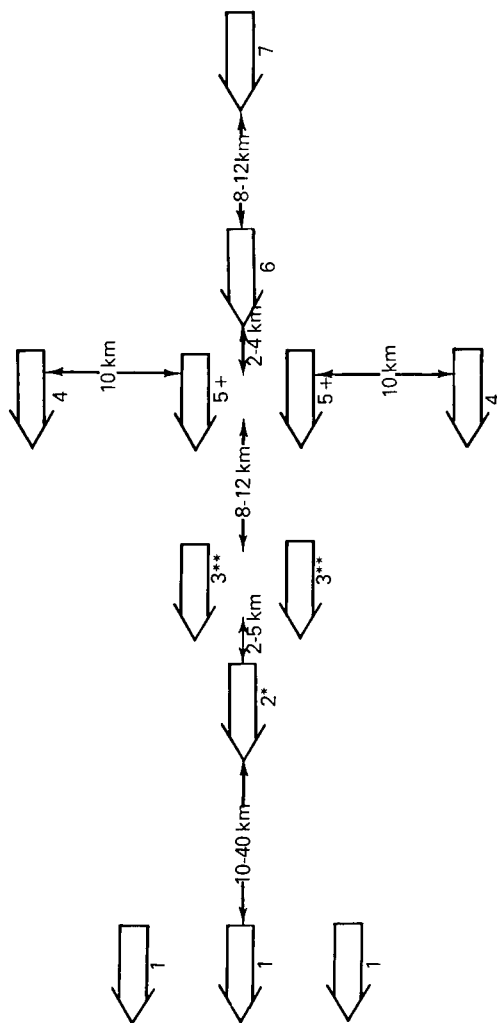
*A forward detachment is formed only when there are specific combat missions to be accomplished, such as the seizure of key lines of communications, raids to capture prisoners, or reconnaissance in force. The forward detachment is formed primarily from the assets of the advance guard.

** An advance guard is established for each lead regiment; normally, it is a reinforced infantry battalion (usually with artillery).

+ The main body usually marches with two or three axes.

Figure 27. Basic Order of March for a Cuban Infantry Division in a Movement to Contact.

Cuban doctrine includes specific active and passive procedures for units against air attack. Additional anti-aircraft guns from the army and/or corps may augment organic anti-aircraft guns which are deployed under division control throughout the echelons. Also, machineguns from infantry units are deployed throughout the columns to assist in this task.

b. *Probable Actions at Contact*

(1) *Action by the Advance Guard*

On contact, the lead elements will engage the enemy and attempt to destroy or fix him. If the point and advance party cannot overcome the resistance, they will maintain contact while the advance guard, which contains artillery and tank elements, attempts to destroy the enemy or force his retirement. The advance guard action gives the appearance of a piecemeal operation, since units are allotted as the situation dictates. This rapid employment is part of the reconnaissance effort to define the enemy's disposition, to locate weapons and gun positions, and to determine the extent of the enemy's defense.

(2) *Action by the Main Body*

The division commander, from the information gained by the advance guard, probably will deploy the main body immediately to annihilate the enemy, since rapid and bold action is considered the key to success, especially against a stronger enemy. The Cubans believe envelopment is the best method of isolating and annihilating the enemy. The division commander, having allotted his commanders their tasks, allows them greater initiative and judgment in the rapidly fluctuating meeting engagement, and the pursuit that may follow, than he does in the more deliberate operations.

(3) *Minefield Breaching*

Engineers organic to the division and regiment clear or supervise the clearing or breaching of obstacles and minefields. Mine detectors and probes are used. Antitank mines are neutralized and removed for possible use elsewhere. Antipersonnel mines may be detonated on the spot. Bangalore torpedos, mine plows and mine rollers are also used to clear paths through obstacles and minefields. Mines may also be detonated by a cable dragged between tanks across a minefield.

c. *Actions in Conducting either a Meeting Engagement or a Hasty Attack*

Actions in both the meeting engagement and the hasty attack are characterized by speed. A meeting engagement was defined in the section above; it is a collision between opposing forces on the move. A hasty attack, whenever possible, is conducted from the march to penetrate thinly occupied and hastily prepared defensive positions by rapid, deep thrusts, disrupting the entire defensive system. The Cubans believe that a hastily prepared defensive position is unlikely to have a fully coordinated defensive plan and that its fire support

will be relatively poor. They emphasize speed in the planning, preparation, and execution of the attack consistent with an adequately coordinated fire plan.

The infantry division normally attacks with two regiments in the first echelon and one regiment in the second. At times, three regiments may be deployed in the line for the attack. For an infantry regiment, the first echelon usually consists of two reinforced battalions and the second, of one battalion. The battalion attacks on a frontage with two reinforced companies in the first echelon and one in the second. Tanks will normally deploy in the second echelon.

d. *The Deliberate Attack*

The deliberate attack requires a relatively long period of preparation. It is characterized by careful and detailed planning, intense reconnaissance activities, and the deployment of numerically superior forces in a specific area. In fact, a Cuban infantry division will generally attack in two echelons, on a narrow front, approximately 2 to 4 kilometers in width. Initial objectives are 2 to 4 kilometers behind the Line of Departure, and final objectives may be up to 15 kilometers deep. If the Cubans attack on a wider front of 4- to 6-km in width, they may employ three echelons. If an assailable flank exists, the division commander will use one or more of his regiments to try to outflank the enemy.

The regiment also attacks in two echelons. Normally, the first echelon will consist of two reinforced battalions on a regiment front of 2 kilometers. Objectives are allocated only to the first echelon battalions; the second echelon, normally consisting of one battalion, follows the first. Both echelons are considered committed.

Battalions and companies normally attack with one echelon and a reserve. Orders to the company commander usually are very specific and give the commander little scope for independent action.

The pattern of a typical deliberate attack by an infantry battalion as part of a regiment attack might be as follows:

- Battalion in division assembly area approximately 8 to 30 kilometers behind the FEBA at D-minus-2 day.
- Battalion moves to the regiment attack position under cover of darkness some 5 to 10 kilometers behind the FEBA at D-minus-1 day.
- Under cover of division artillery, which usually will be reinforced with corps and army artillery, the assault echelon moves forward in close formation to the company assault positions within 200 meters of the objectives.
- At this point, the infantry platoons, with each of their squads divided into two teams, advance in a skirmishing formation with 3 to 5 paces between individuals and 7 or 8 paces between teams. They follow their

own artillery concentrations very closely and are prepared to suffer some casualties in order to take maximum advantage of their own fires. Mechanized infantry platoons will assault either mounted or dismounted, but most likely the latter to maximize firepower. Assault formations are illustrated in figures 15 through 20.

- Depending on the terrain, the tanks will time their movement to lead the infantry in the assault.
- The assault is made in a continuous rush. As soon as the squads are within range, handgrenades are thrown to cause confusion, smoke, dust, and casualties. As the squads reach the enemy positions, all members fire their weapons and close with the enemy to destroy him at pointblank range.
- On clearing the objective, the assault force will continue its attack and exploit beyond the objective while the support echelon consolidates on or near the objective. If the assault echelon has suffered heavy casualties, exploitation will be carried out by the support echelon.
- If the assault should fail, the Cubans will dig in as close as possible to the enemy position and await reinforcements.
- Upon seizure of the objective, the Cubans reorganize rapidly.

e. *The Pursuit*

The pursuit (exploitation) will start when the enemy is routed or attempts to break contact in a preplanned withdrawal. When it becomes apparent through intensified reconnaissance that the enemy is planning or has just begun a withdrawal, an attack is launched immediately to confuse him and to disrupt his plans. Once it is clearly determined that a withdrawal is in progress, pursuit is initiated. All available units are committed immediately, piecemeal if necessary, to insure that contact is maintained with the retreating enemy. Once initiated, pursuit can be terminated only on orders from a higher (usually at least corps) headquarters.

In the pursuit, close and continuous pressure on the enemy is considered necessary to prevent his regrouping or reassuming the defensive. As soon as possible, the Cubans form two or more columns, one to exert direct pressure and the other(s) to move on either flank parallel to the withdrawing enemy in an attempt to overtake, encircle and then destroy him (figure 14). The flanking columns are organized from units of the support echelon and the reserve. They are often mechanized and reinforced with tanks. Speed is emphasized and enemy strong points are bypassed so that critical road junctions and defiles on the enemy withdrawal routes can be seized and destroyed.

f. *Obstacle Crossing*

(1) *General*

Since Cuba has few major natural obstacles, the military has not conducted much training in breaching obstacles. However, apparently as a result of its experience in Angola, where Cuban offensive operations against the anti-Popular Movement for the Liberation of Angola (MPLA) forces were hindered by their inability to cross rivers rapidly, the Cubans have increased their obstacle-crossing capabilities with the introduction of new bridging equipment to complement the amphibious vehicles. The obstacle-crossing capabilities, however, have yet to be tested under combat conditions in a conventional war.

Whenever possible, crossing of obstacles would be made at night or under conditions of poor visibility. If it is necessary to make a crossing by daylight, smoke probably would be used to conceal both the preparations and the operation.

The Cubans consider the following principles as the key to a successful obstacle crossing:

- Reconnaissance.
- Early planning and thorough organization.
- Destruction of the enemy in the area.
- Deception.
- Improvization of crossing aids.
- Speed and surprise.
- Crossing on a broad front.
- Swift development of the attack on the far bank.
- Massing of forces against enemy weak points.
- Air defense.

The Cubans execute two types of river crossings: the hasty crossing and the deliberate crossing. The hasty crossing is a swift, uninterrupted movement normally conducted from the line of march. The deliberate crossing is undertaken only if a hasty crossing has failed or if a large, well-defined water obstacle has to be crossed and breached.

(2) *Nonengineer River Crossing Capability*

The Cubans have a limited capability for nonengineer river crossing. The mechanized infantry units, particularly those equipped with the amphibious BRDMs and the BTR-60s, can swim, whereas all units which have vehicles such as the BTR-40 and the BTR-152, can only wade or need bridging to cross rivers. Of the tanks, only the PT-76 light tank is amphibious. The T-54/55 and the T-62 are capable of snorkeling with special equipment. Cuban guns and prime movers are not amphibious and rely on engineer river crossing facilities. The K-61 (GPT) tracked amphibian, which is not armored, is capable of transporting people and several tons of equipment across water.

(3) *Engineer Equipment for Water Crossing*

Cuban engineer equipment for water crossing is illustrated in appendix M. In addition, the Cubans also have some Soviet assault boats capable of carrying about a squad of men.

Figure 28 illustrates a reinforced mechanized infantry battalion crossing a water barrier. If the Cubans do not use snorkeling equipment, as portrayed here, they will employ bridging equipment utilizing the same general procedures as illustrated.

There are several vulnerabilities during a Cuban water-crossing operation. Exact crossing sites may be prematurely revealed by reconnaissance personnel, thus enabling the defender to take effective countermeasures. Snorkels are vulnerable to hostile fire and may be damaged prior to the crossing. Moreover, once the tank is sealed for a river crossing it cannot fight, since the turret is locked and the main gun tube blocked. Although the snorkel may be quickly blown off once the tank has emerged from the water, the tank cannot engage in sustained combat until de-sealing has taken place—a process that takes about 20 minutes. Because of the vulnerabilities presented by deep fording, in addition to the lack of experience in tank snorkeling operations, the Cubans probably prefer to transfer their tanks to the opposite bank by constructing bridges.

(4) *Dry Gap Crossing*

Cubans also have limited dry gap crossing capabilities. Engineer equipment which is suitable for use for crossing dry gaps is illustrated in appendix M, and includes TMM, KMM, and MTU-20 (T-55) vehicle-launched bridges. The Cubans would also use bulldozers and other earth-moving equipment to fill in gaps where possible.

Section D—Defensive Operations

1. GENERAL

The Cubans—like the Soviets—view defense as an intermediate stage in the overall, broad offensive strategy adopted in order to:

- preserve friendly forces while weakening those of the enemy.
- gain time to concentrate forces for the offensive or counteroffensive.
- economize forces to allow an offensive to be mounted in another area.
- consolidate captured objectives.
- cover a withdrawal.

The defense of the island is based on repelling a large-scale parachute and amphibious landing by enemy forces. Cuban defenses would be under the overall command of the President of the Republic and all the forces, including MININT, would be under operational control of MINFAR. The naval tactics for defending Cuba are outlined in section G below. The DAAFAR would provide close air support as discussed in section B above in support of naval and army forces. The

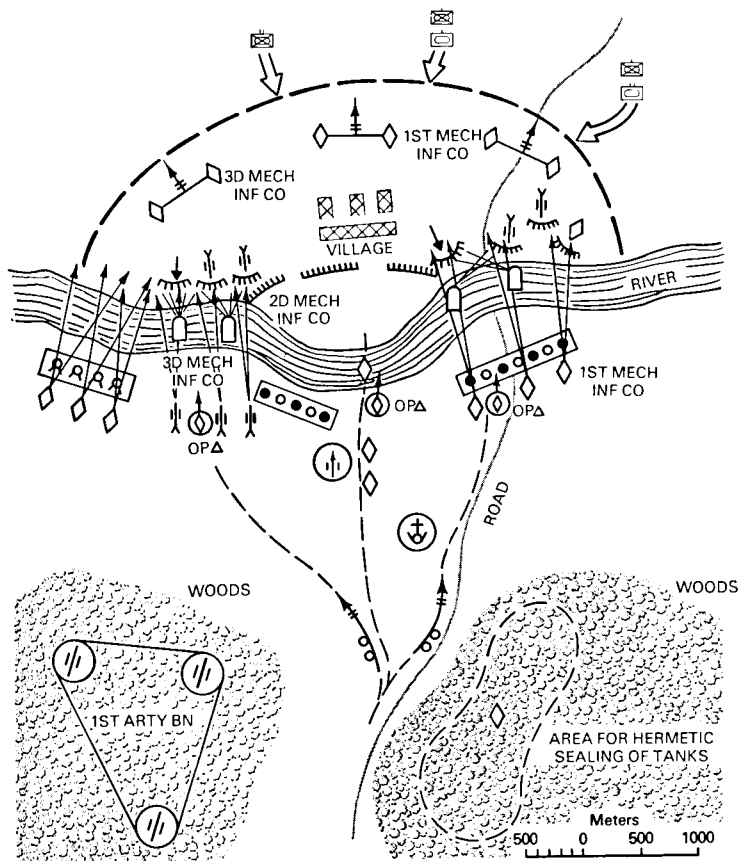

KEY

- | | | | |
|--|-----------------------|--|---|
| | APC | | Mechanized Infantry Company on the March |
| | Tank | | Mechanized Infantry Company, Reinforced With Tanks, in the Attack |
| | Antitank Gun | | Explosives |
| | Reconnaissance Patrol | | Mixed Antitank/Antipersonnel Minefield |
| | Mortar Section | | Light Machinegun |
| | AAA Battery | | |

Figure 28. A Reinforced Mechanized Infantry Battalion Forcing a Water Barrier (with tanks snorkeling) to Execute a Double Envelopment of a Village.

Cuban Army defense of the island would begin at the shoreline, where coastal artillery would fire at the ships offshore and the "antilandings" troops, composed of regulars, reservists and probably members of the Civil Defense and EJT, would join members of the MININT Border Guard Troops (TGF) in attempting to prevent the enemy from landing. Should the enemy succeed in establishing a beachhead, the more mobile forces, such as the mechanized infantry and armor units, would be primarily responsible for containing and pursuing the enemy forces until they are destroyed. The less mobile forces, such as the infantry and EJT personnel, probably would be primarily responsible for defending key areas in static defensive positions. Should the Cubans be unsuccessful in repelling the attackers, many of the most dedicated personnel most likely would turn to guerrilla warfare and persist until they succeed in routing the invaders or are themselves defeated.

2. FORMS AND TYPES OF DEFENSE

a. Area Defense

The basic form of Cuban defense is the area defense in which major commanders (division and above) are ordered to defend within a certain area until relieved by higher authority. The commanders usually are allowed to position their units within the designated area. The area defense is characterized by detailed and extensive planning and defensive positions are planned in depth. It is designed to provide a stubborn defense in order to deny areas which Cuba considers vital to its survival and to halt the enemy while inflicting significant losses on his men and materiel. The infantry units usually are ordered to engage the enemy decisively and almost always are ordered to hold at all costs with no thought of withdrawal. The mechanized infantry and armored divisions usually are held in strategic reserve and are the principal counterattack forces.

Figure 29 gives the average widths and depths under nonnuclear conditions for infantry maneuver units on or near the FEBA. Frontages and depths for mechanized infantry and armored units are about 30 to 50 percent greater than infantry maneuver units at the battalion level and above. Frontages and depths for all maneuver units, battalion and above, under nuclear conditions would be about 50 to 100 percent greater than in conventional operations.

Area Defense		
	Frontage	Depth
Army	20-40 km	20-50 km
Corps	12-30 km	20-30 km
Division	6-12 km	8-10 km
Regiment	3-6 km	2-5 km
Battalion	1.5-3 km	1-2 km
Company	600-800 m	500-700 m
Platoon	300-400 m	300-400 m

Figure 29. Average Frontages and Depths for Infantry Units on the FEBA in Area Defense. (Factors influencing variations include weather, terrain and forces available.)

b. *Deliberate and Hasty Defense*

The Cubans use two types of defense: the deliberate and the hasty. The deliberate defense is organized whenever the Cubans have several hours or more to organize a defensive position or whenever the advance is going to be halted for more than a few hours. The hasty defense is most often utilized when the Cubans have very little time to organize a defense or when the advance guard of the first echelon units are stopped in their offensive action. The major differences are the size of the sectors and the location of the tank assets. In the hasty defense, the width of the front is smaller, with smaller gaps between strong points. Tanks are also located farther back because there is not sufficient time for tanks to dig in. There is also less construction of trenches and obstacles as well as less employment of mines in the hasty defense. The defenses have similar dispositions of units and strongpoints.

3. ORGANIZATION OF DEFENSE BELTS

a. *Organizational Principles*

Cuban defensive doctrine stresses the need to avoid establishing any set pattern and calls for changing the pattern of defensive employment as often as possible. However, because of the extensive preparations, few significant changes are implemented once the units are dug in.

The defense is organized in depth. Each maneuver unit from platoon up to division usually is organized two on line and one in back; that is, a platoon would have two squads on line and one behind (figures 30-32). In some situations, all three maneuver elements may either be on line, or one may be forward and two behind (figure 33). In some cases, platoons and companies may be organized three on line with a small reserve. For maneuver units of the battalions, regiments and divisions which are on the front lines, the units nearest the FEBA are in the first echelon and those units behind them are in the second echelon. Both echelons are considered committed. Thus, a regiment usually would have two battalions in the first echelon and one in the second echelon.

The battalions are the basic component of the defensive organization (figure 33). Reserves and dedicated antitank units are found at battalion level and above. Small reserve forces occasionally are organized at company level.





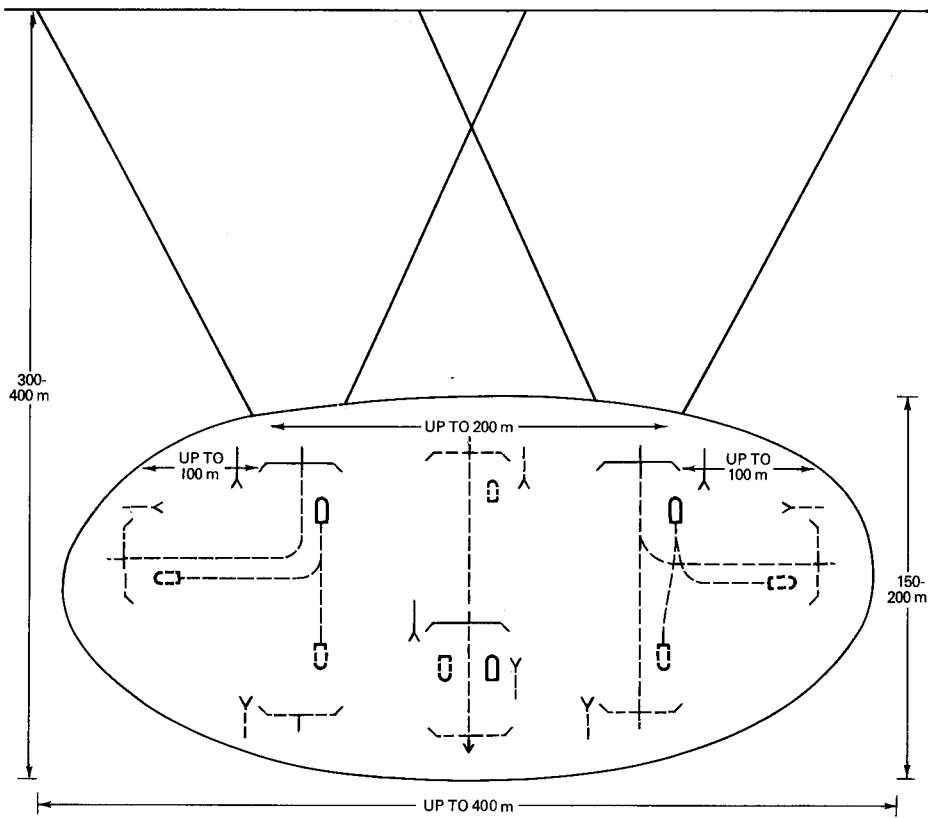

A division usually participates in defensive operations as part of a larger force. Figure 34 illustrates the organization on the FEBA of a typical infantry division which has two regiments in the first echelon (each regiment having three battalions) and one regiment (with three battalions) in the second echelon. Three defense lines are established; two are in the division's first echelon and one is in the second.

b. *Defense Belts*

Normally, the corps will deploy two divisions in the first echelon and one in the second, although it may deploy as many as four in the first echelon and







KEY

-  Primary Position of Squad. There would be up to 10 meters between each squad member.
-  Alternate Position of Squad.
-  Primary Position of APC.
-  Alternate Position of APC.
-  Primary Position of RPG-7.
-  Alternate Position of RPG-7.
-  Sector of Fire.

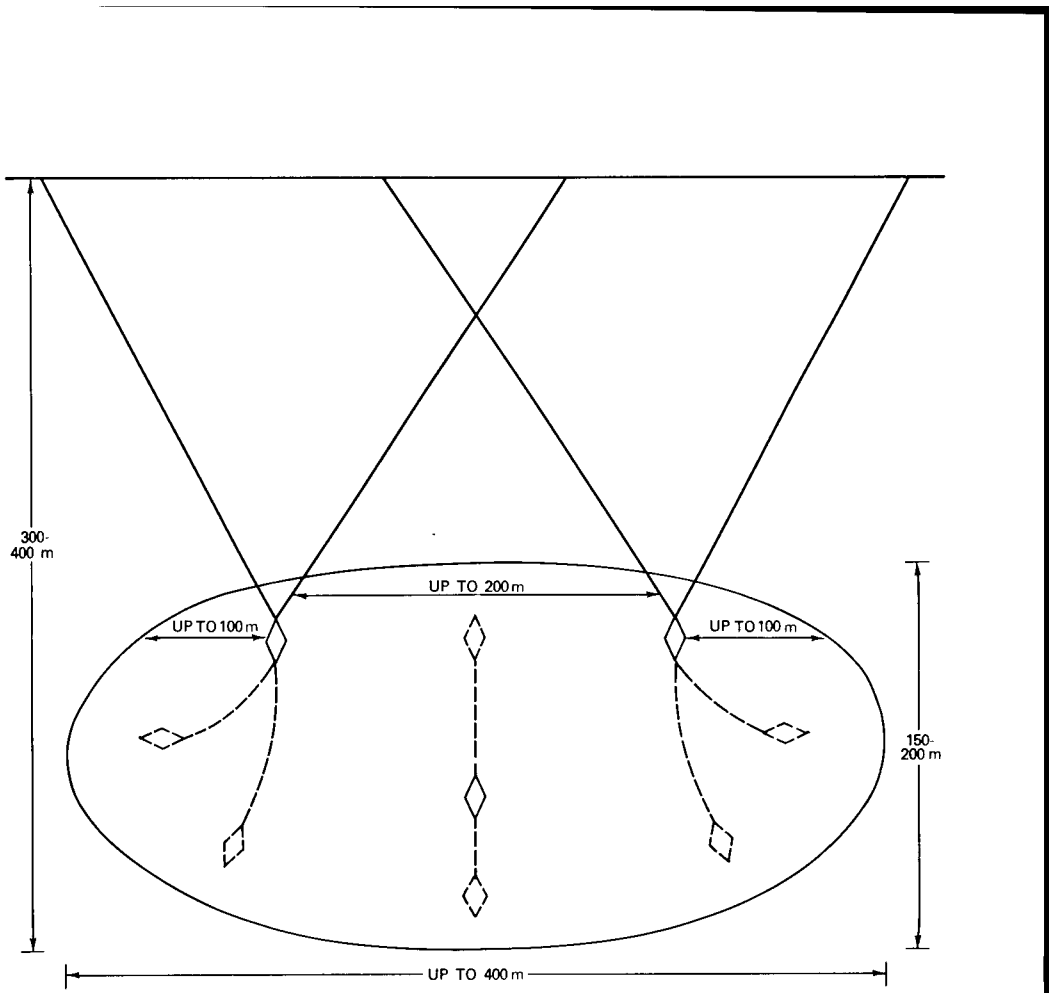
All three squads could be forward. All squads would be in fortified positions. Barbed wire, minefields and other obstacles are placed in front and covered by fire.

Figure 30. Mechanized Infantry Platoon in Position Defense on the FEBA.



- KEY**
-  Primary Position of Tank
 -  Alternate Position of Tank
 -  Sector of Fire

All three tanks could be forward. Tanks would be in defilade. Barbed wire, minefields and other obstacles are placed in front and covered by fire. Tank platoons behind the FEBA probably would not be dug in to retain mobility.

Figure 31. A Tank Platoon in Position Defense on the FEBA.

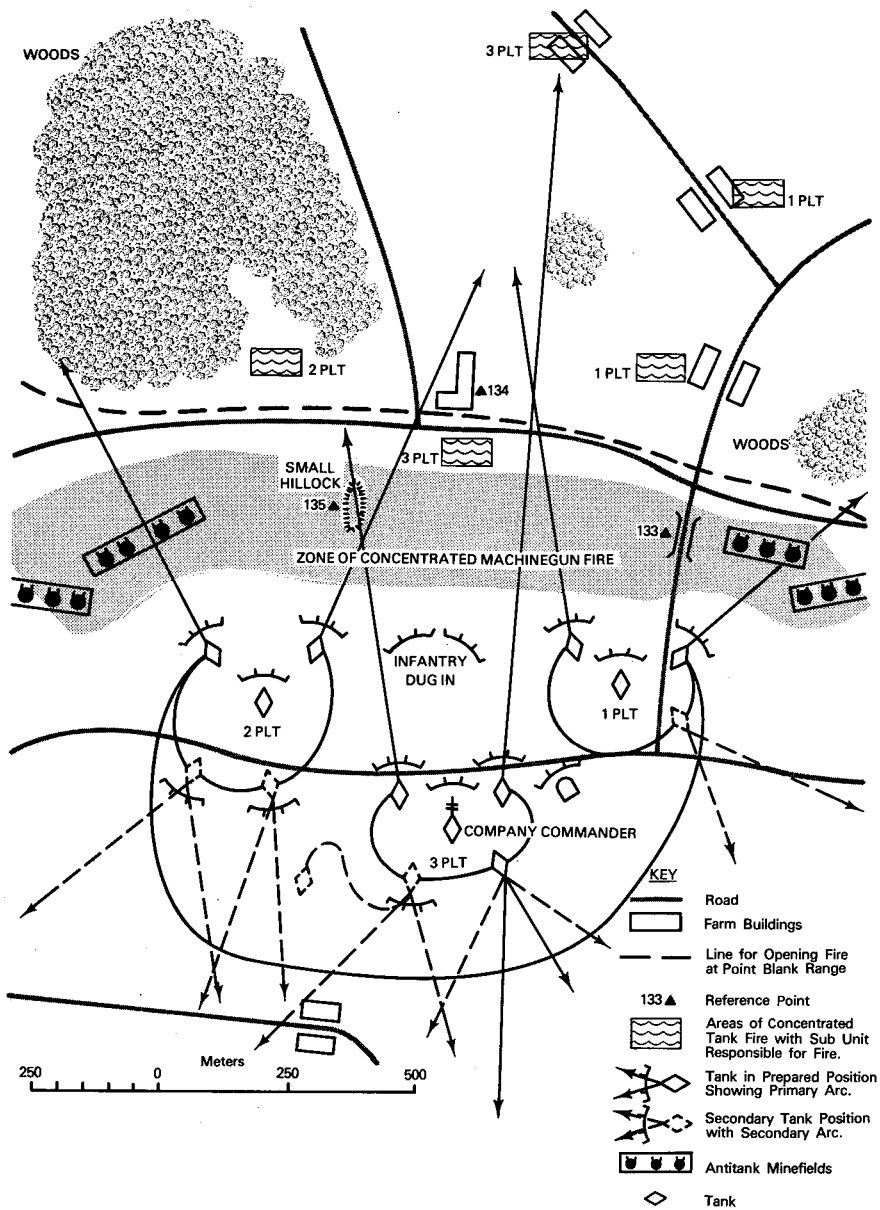

Figure 32. A Reinforced Tank Company's Defensive Positions.

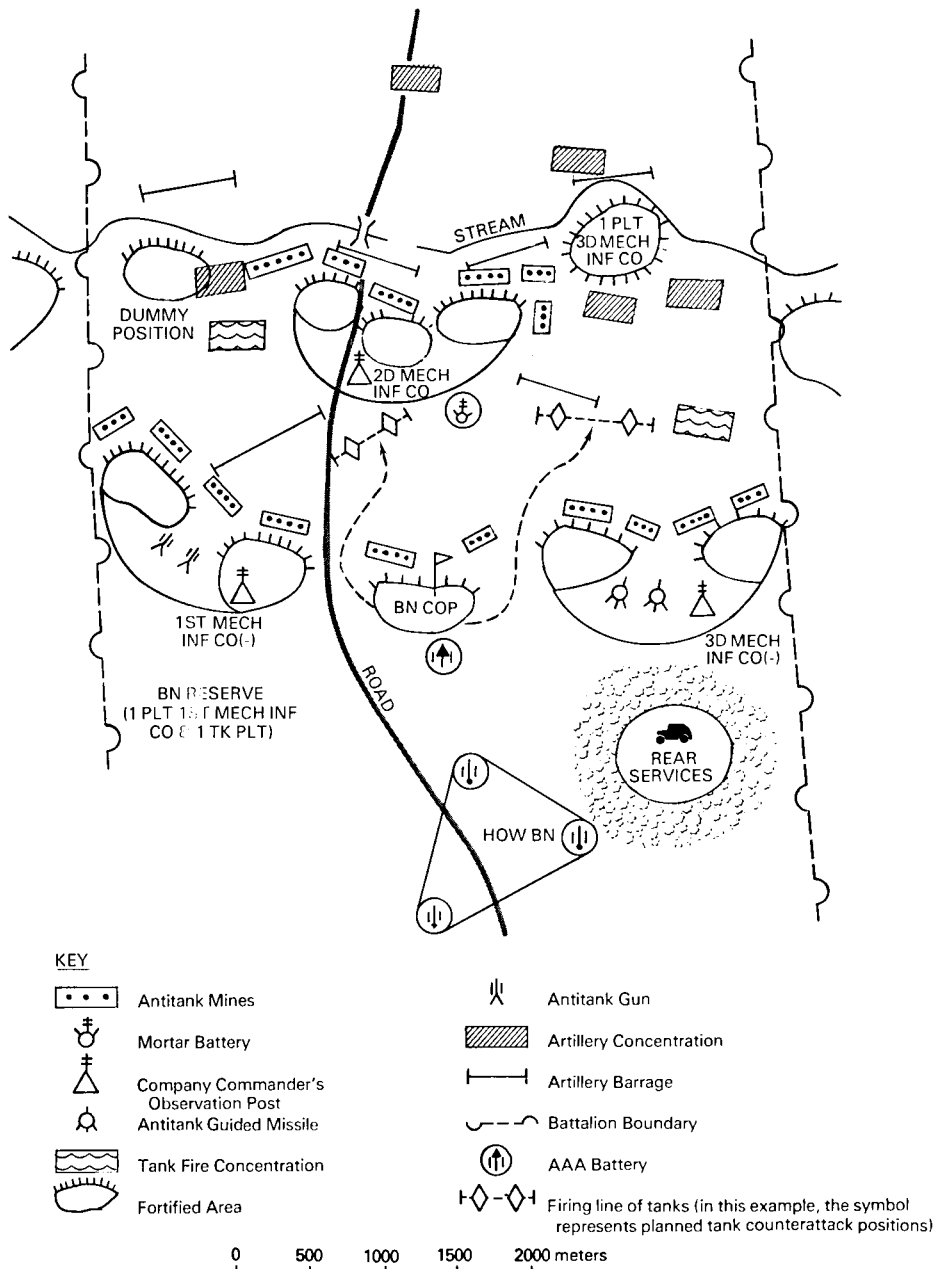
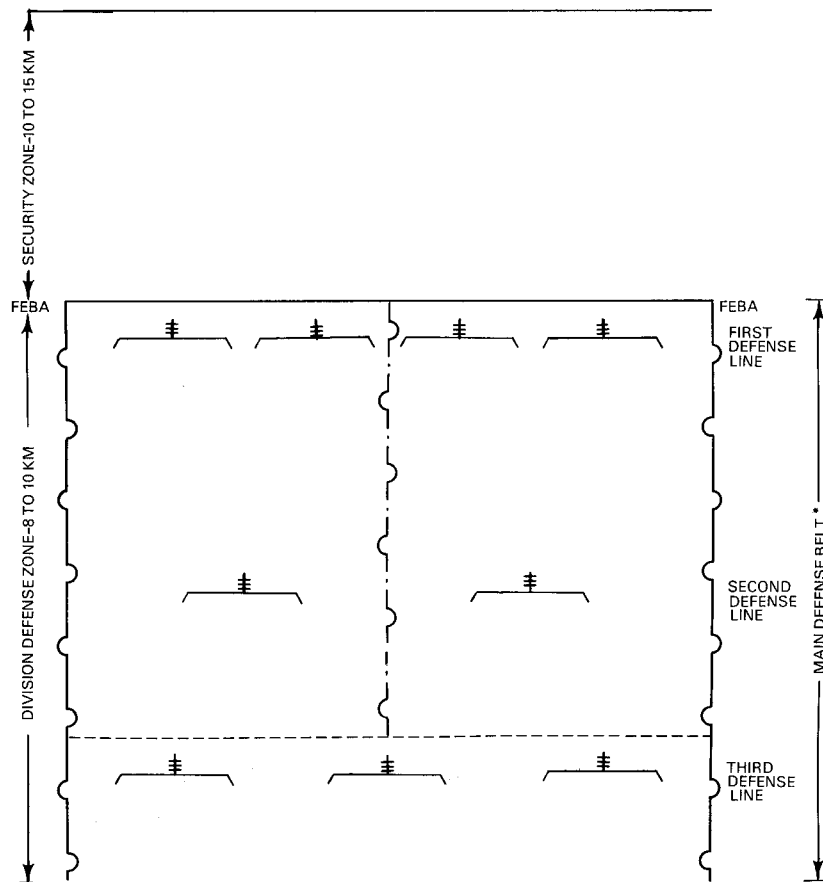
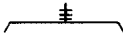
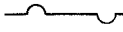



Figure 33. A Reinforced Mechanized Infantry Battalion in the Defense.



KEY

-  Battalion Defense Position
-  Division Boundary
-  Regiment Boundary

*See Chapter 5-D-3-b and Figure 36 for explanation.

Figure 34. Defense Lines in Division Defense Zone.

two in the second. The army probably will deploy two corps in the first echelon and one in the second, although it may employ three or even four in the first echelon and none or one in the second echelon.

At corps and army level, Cuban defenses are organized into defense belts. There are five components of the defense belts: the reconnaissance zone, the security zone, the main defense belt, the second defense belt and the third defense belt (figure 35).

(1) The mission of the troops in the reconnaissance zone is to warn of enemy movements and report on the size and locations of units, troop concentrations, command and control elements, locations of reserves and logistical elements, and probable main thrusts. The reconnaissance zone, which can extend out to 50 kilometers, is manned by the reconnaissance units of the divisions, corps and armies.

(2) The mission of the forces in the security zone is to force the enemy to deploy before reaching the main defense belt. The security zone, which is up to 15 kilometers deep, is established by units from either the second defense belt of corps and/or army units. Units in the security zone are reinforced with artillery and engineer assets. Static delaying positions are established, usually by the corps and/or army units.

Each maneuver unit on the FEBA from company to division establishes at least one security outpost over which it has operational control. For example, the company will establish a reinforced squad outpost within 500 meters of its front line units; a battalion will establish a reinforced platoon outpost within about 2,000 meters of its front line units; a regiment will establish a reinforced company outpost within 3 to 6 kilometers of its front line units; and a division will establish a forward detachment composed of a reinforced battalion up to 10 kilometers from its front line units. The forward detachment is a mobile combined arms team which usually has tanks as well as attached engineer and artillery assets. Unlike the security outposts, which establish static positions, the forward detachment aggressively seeks to engage the enemy. Corps and/or armies may also deploy reinforced combat units in the security zone.

(3) The mission of the forces in the main defense belt is to stop a hostile attack and destroy the enemy forces. The main defense belt, which is up to 10 kilometers deep, is manned principally by infantry and perhaps mechanized infantry divisions comprising the first echelon of the corps and/or army. Within the main defense belt are those forces necessary to conduct the defense, including tank, artillery, antitank and air defense units; and the division main and alternate command posts.

(4) The mission of the forces in the second defense belt is to contain enemy breakthroughs of the main defense belt until a counterattack can be launched. It is about 8 to 10 kilometers to the rear of the main defense belt and is about 10 kilometers deep. It is usually established and defended by the corps or perhaps the army's second echelon infantry, mechanized infantry and

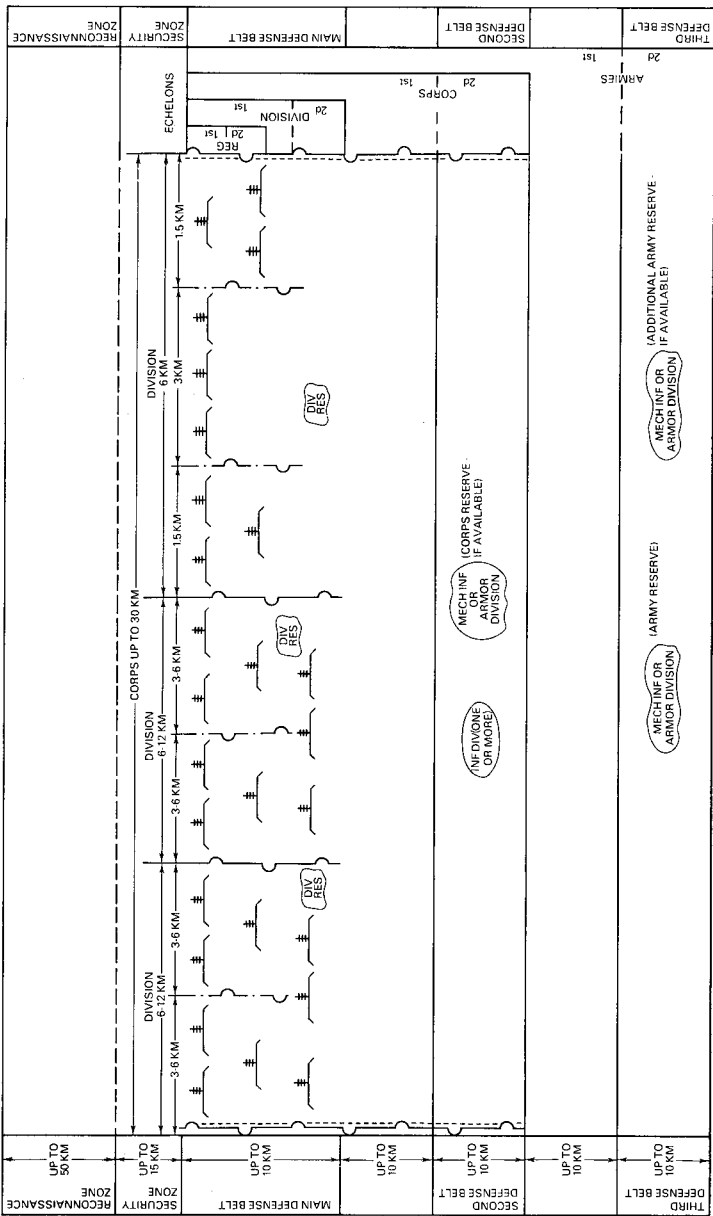

1. This schematic representation of Cuban large-scale defensive operations is not to scale. Primarily it portrays the corps defensive posture, although the third defense belt, that of the army, has been added.
2. The defense is organized on the basis of battalion defense areas located on terrain features covering important avenues of approach and oriented to deliver fire into adjacent battalion defense areas.

Figure 35. Large-Scale Defensive Operations.

armored divisions which deploy to assembly areas in the second defense belt after completing their mission in the security zone. It usually contains prepared, but unoccupied, defense positions in its forward area. The corps and/or army's main and alternate command posts, some artillery, and portions of the corps reserves are located in the second defense belt.

(5) The mission of the forces in the third defense belt is to prepare to mount a counterattack or, if the enemy forces have broken through both the first and second defense belts, to man prepared defensive positions to stop enemy penetrations. It is about 10 kilometers to the rear of the second defense belt and is about 10 kilometers deep. It is manned by the army units, usually its second echelon forces, which is composed of at least one mechanized infantry and/or armored division.

c. Principles for Deployment

(1) Command, Control and Communications

Unit commanders will usually place their forward command post behind the center of the first line (or echelon) of their unit. For example, a division commander normally will locate his forward command post just behind a first echelon regiment. The division main command post will be located with the division's second echelon units. Commanders at all levels are expected to conduct personal reconnaissance. Coordination and communications are established with adjacent, higher and lower units.

(2) Fortified, All-around Defense

Each unit, especially those on or near the front lines, will establish well dug-in, camouflaged, fortified positions with strong points that are capable of 360° defense. Communications trenches connecting frontline positions are usually dug, and overhead cover is normally provided for bunker entrances, troop shelters, individual foxholes, and machinegun emplacements. Minefields and obstacles are established especially in front of the FEBA, and are also emplaced throughout the entire defensive organization (including the areas between the defense belts), and are covered by observation and fields of fire. Alternate and dummy positions are established, too. All units establish interlocking fields of fire and obstacles with adjacent units. Tanks, armored personnel carriers and artillery pieces of the first echelon battalions and regiments normally are dug in; those behind the first echelon regiments are more mobile.

(3) Reserve Forces

Cuban forces retain a small mobile reserve at battalion level and above; the reserve unit is usually a reinforced unit two levels below the parent unit. For example, the battalion normally has a reinforced platoon as its reserve force and the regiment has a reinforced company. The reserve force is usually taken from the second echelon of the parent unit and is composed of tanks and/or mechanized infantry. Reserves at the battalion and regiment level usually

are positioned with or near the second echelon of the parent unit, although they may be placed just behind the first echelon. Some infantry divisions have a tank regiment which usually will supplement the division reserve. The division reserve, which is usually tank heavy, is normally located near the second echelon regiments. Corps and/or army reserve units normally are mechanized infantry or armored divisions, and are located in the second or third defense belt.

(4) *Counterattacks*

Plans for launching counterattack forces are made at every level beginning with companies and are part of the initial defensive planning. Although the reserve unit usually is the principal counterattack force, other units may be used, particularly those in the second echelon. Counterattack forces usually contain tanks and mechanized infantry units.

Normally the authority of the next superior commander is required before counterattacks can be launched. The counterattacks usually consist of fire from all types of weapons followed by infantry attacking from a different direction. In the counterattack, the Cubans will try to gain surprise with a flank attack while the enemy is reorganizing, or will counterattack at night.

(5) *Antitank Defenses*

Each maneuver unit from platoon up to army plans antitank defenses which include obstacles and mines. Antitank weapons include tanks; the RPG-7, which is issued to each squad; SNAPPER and SAGGER antitank guided missiles; and 57-mm, 76-mm, and 85-mm guns which are organic to infantry and mechanized infantry battalions, regiments and divisions. If necessary, field and antiair defense artillery weapons can be used in antitank defense. Antitank defenses and weapons are located along likely avenues of approach into which the Cubans try to channelize the enemy to form "killing zones." The antitank defenses and weapons are emplaced from the security zone back through the third defense belt, with the majority of them in the security zone and main defense belt.

(6) *Artillery*

The Cubans plan for extensive use of artillery in defensive operations. In addition to the artillery organic to mechanized infantry and armored regiments and divisions, the Cubans will assign regiment artillery groups (RAGs) and division artillery groups (DAGs) composed of artillery pieces from corps and army assets.

Fire plans are carefully organized and control is highly centralized. Artillery fire is concentrated against the enemy's most important forces, against key targets in the enemy's rear, and to cover the flanks of Cuban units. The Cubans stress the ability to shift fires rapidly. They believe that effectiveness of fire in the defense is achieved by surprise, and accurate, massed use of artillery fires.

The Cubans use five sequences, or phases, for defensive fire planning.

- Sequence I consists of long-range fires planned to disorganize and weaken enemy forces.
- Sequence II involves fires massed against assembly areas, command posts, and artillery positions prior to the attack.
- Sequence III consists of barrage and final protective fires planned in depth throughout the main battle area.
- Sequence IV consists of direct fires against tanks that have broken through the forward defenses.
- Sequence V consists of fires in support of counterattacks.

(7) *Rear Services*

Most major division, corps and/or army rear service units are positioned at or behind the third defense belt, with unit field and combat trains located as close to the FEBA as possible. Usually, however, field and combat trains are located in well-camouflaged positions near the second echelon positions. POL, ammunition and other important supplies will be pre-positioned throughout the defensive zones. The Rear Services headquarters usually is located about 20 to 40 kilometers behind the FEBA.

d. *Basic Organization of the Cuban Infantry Division in the Defense*

Figure 36 illustrates a probable deployment of a Cuban infantry division in the defense.

4. CONDUCT OF THE DEFENSE

a. *In the Division Security Position*

(1) *Screening Force*

Troops from the division reconnaissance battalion will make contact with the enemy about 8 to 16 kilometers in front of the FEBA. They will fall back under pressure without becoming decisively engaged and will pass through the regimental security forces. Screening forces will direct long-range artillery and air strikes against attacking forces.

(2) *Security Forces*

After withdrawal of the screening force, the regimental security force, supported by air and artillery strikes, will conduct a stubborn holding action. When further resistance is considered unprofitable, the division commander will order a withdrawal through the first echelon regiments to the second regiment echelon. As the enemy pressure increases, the battalion and company security forces will also be withdrawn.

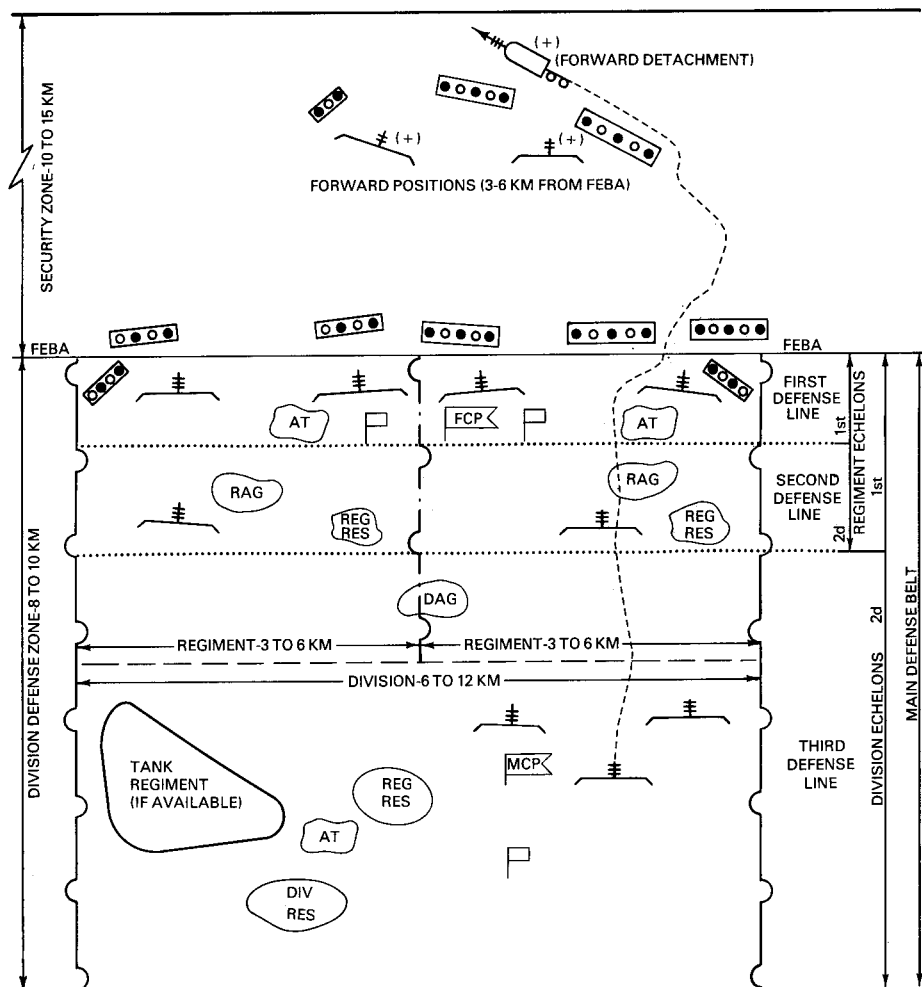

KEY

- | | | | |
|--|---|--|---|
| | Division Boundary | | Division Reserve Disposition Area |
| | Regiment Boundary | | Regiment Artillery Group (RAG) |
| | Battalion Defense Position | | Division Artillery Group (DAG) |
| | Reinforced Battalion in Forward Detachment Role | | Antitank Reserve Unit (antitank guns, SAGGER Missiles and/or Tanks) |
| | Reinforced Company Defensive Position | | Regiment Command Post |
| | Antipersonnel/antitank Minefield | | Division Main Command Post |
| | Regiment Reserve Disposition Area | | |

Figure 36. Basic Organization of the Infantry Division in the Defense.



The Cubans usually deploy infantry with tanks. These are T-54/55s tanks.

b. *In the Division Main Defense Belt*

(1) *Preassault*

An intense counterbattery fire plan will be fired to preempt and, if possible, neutralize the enemy's preparatory bombardment. Likely enemy assembly areas and lines of departure will be targeted to disrupt his attack. Troops in the defensive positions will occupy shelters to protect them against nuclear, chemical and conventional fires. Radio silence will be maintained.

(2) *The Assault*

As soon as the enemy launches his assault on the division main defense belt, fires from all available weapons and supporting artillery will be used to separate hostile tanks from their accompanying infantry. The first echelon battalions of the frontline regiments in the division main defense belt, in accordance with doctrine, will not withdraw even if bypassed or surrounded. As enemy penetrations are made, the second echelon battalions of the regiments will either launch previously prepared counterattacks in an attempt to destroy the penetration and restore the integrity of the FEBA or endeavor to contain the penetration from alternate positions prepared in depth.

c. In the Division Second Echelon

The principal mission of the second echelon forces is to launch counterattacks to destroy enemy penetrations which have survived various counterattacks delivered by the regiments in the three defense lines. At division level, a counterattack force is formed which is normally a mobile combined arms group and is usually deployed behind the second echelon position. The counterattack force is under the control of the division commander. Those commanders having a tank regiment will employ the regiment as an additional counterattack force. If the second echelon forces are unable to stop the enemy, the division commander will inform the corps and/or army commanders who will then direct him to commit his entire second echelon either to:

(1) destroy the enemy penetration and restore the FEBA, or

(2) strengthen and defend the division second echelon defensive positions in order to contain the penetration and cover the withdrawal of the division first echelon.

At this point, the corps and/or army commander assumes command of the forces. The commander either will commit the reserve forces from the second and/or third defense belts, or order a withdrawal of the frontline divisions.

Section E—Retrograde Operations

1. GENERAL

Cuban-adopted Soviet doctrine stresses that the overall objective of retrograde operations is to create a more favorable situation for the initiation or resumption of the offensive. Retrograde operations are employed by the Cubans in both the offense and defense, either voluntarily or as a result of enemy pressure, to preserve their forces and to gain or maintain the initiative.

Retrograde operations fall into three categories:

- Withdrawal, an operation, either voluntary or as a result of enemy pressure, in which a force in contact disengages from the enemy.
- Delaying action, an operation in which a force under enemy pressure trades space for time. The Cubans fight a delaying action only when the enemy force has the initiative and they are unable to fall back in any other way.
- Retirement, a voluntary movement to the rear by forces not in contact with the enemy.

Retrograde operations are undertaken for one or more of the following reasons:

- To maintain the integrity of one's own forces.
- To harass, exhaust, resist, delay and inflict punishment on the enemy.
- To disengage from combat.
- To gain time without becoming decisively engaged.
- To permit the use of elements of a force elsewhere.
- To avoid combat under undesirable conditions.

Whenever possible, retrograde operations take place at night. If the Cubans are forced to conduct a retrograde operation by day, they employ smoke to screen their movement. Retrograde operations are covered by intense artillery fire and air strikes and may be preceded by local counterattacks. Maximum use is made of the engineers to construct obstacles.

2. THE WITHDRAWAL

The withdrawal (figure 37) is initiated when units in contact with the enemy are ordered to disengage and begin their movement to the rear. The division commander issues a very detailed plan which covers the following actions:

- Small parties from all subunits are sent out to reconnoiter and plan the rendezvous areas and defensive positions prior to the start of the withdrawal.
- Field trains, nonessential supplies, equipment and personnel are sent to the rear.
- Covering forces, normally consisting of no more than one-third of a unit's total strength, are formed especially at the battalion and regiment levels to cover the withdrawal. These forces usually are tank-heavy, and their size depends on anticipated enemy pressure. If the enemy pressure is expected to be light, then the covering force may be composed of a reinforced unit two echelons below the parent unit (example: a reinforced platoon from a battalion). If the enemy pressure is expected to be heavy, then the covering force will be composed of a reinforced unit one level below the parent unit (example: a reinforced company from a battalion).

In conducting the withdrawal, the division commander orders the quickest possible withdrawal of each unit and minimizes the number of rendezvous areas. Each unit will be ordered to march as far towards the division rendezvous area as possible without stopping. The rendezvous areas usually are areas in which larger units, such as the battalion or regiment, wait for the subordinate elements to consolidate. As soon as the subordinate elements are accounted for, then the major unit marches to the next area. Normally, company rendezvous areas are not established, and the battalion rendezvous areas may not be established either.

The following illustrates the principles of a probable withdrawal by a mechanized infantry regiment. Within each frontline battalion, one of the

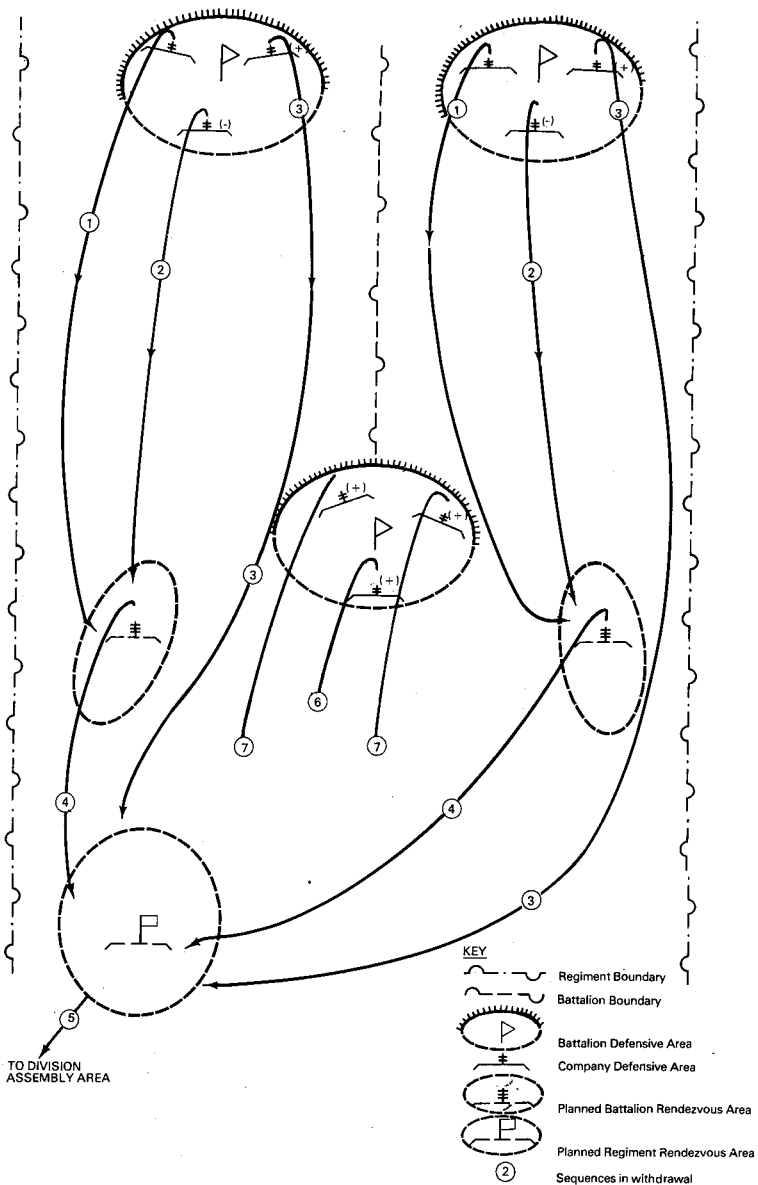

Figure 37. The Withdrawal for a Mechanized Infantry Regiment.

frontline companies (phase 1 of figure 37) withdraws and then is followed by the second echelon company (phase 2). The other frontline company (phase 3), which is reinforced, acts as the covering force for the battalion and remains in the positions occupied by both frontline companies in order to confuse the enemy. It will also attempt to conduct the same type of combat operations as those which preceded breaking off of combat. The units in phases 1 and 2 may either meet at the battalion rendezvous area and then continue immediately to the regiment rendezvous area, or march directly to the regiment rendezvous area (phase 4). Meanwhile, the other frontline company (phase 3) holds its position for either a specified time or until it is notified that the units in phases 1 and 2 have passed the regiment's second echelon battalion. About the time that the units in phases 1 and 2 pass the regiment's second echelon battalion, that battalion, which is reinforced, then assumes the role of the covering force and rear guard. When this battalion assumes those roles, then the reinforced company in phase 3 withdraws to at least the regiment rendezvous area.

The regiment's second echelon battalion then becomes the rear guard for the regiment. It begins its withdrawal after the units in the regiment rendezvous area have begun their march towards the division assembly area (phase 5). It withdraws by phases, with one reinforced company establishing a defensive line one or so kilometers from its original position (phase 6). It maintains this line until the remaining units establish another line about one or so kilometers from its position (phase 7) and then it leapfrogs to another position. The second echelon battalion normally remains as the regiment rear guard even after the regiment arrives at the division assembly area.

The division withdraws as quickly as possible to its new defensive position without occupying intermediate defensive positions. Each regiment is assigned a route of march. At this point, each regiment rear guard is aided by the rear and flank guards formed from either the field army or the corps second echelon. These field army or corps units occupy defensive positions astride the withdrawal routes before the main body of the division begins to move.

3. DELAYING ACTION

While the Cubans carry out delaying actions similar to those of other armies, they do not consider they are fighting a delaying action per se unless the enemy has the initiative and is exerting such pressure that the Cubans have no other way by which to fall back.

4. RETIREMENT

The Cubans will execute a retirement when they wish to avoid combat. If the forces carrying out the retirement are in contact, the initial phase of the operation is in fact a withdrawal. After contact with the enemy is broken, the retirement becomes a tactical march away from the enemy.

Section F--Warfare Under Special Conditions

1. AMPHIBIOUS OPERATIONS

The Cubans have a very limited capability to carry out amphibious operations. They have only a few old Soviet LCM-type craft, but in an emergency, Cuban merchant and fishing vessels could supplement the LCMs. The Cubans probably could support about one infantry battalion with supporting artillery and light armor equipment. The amphibious operations probably would be under the operational control of the Minister of FAR.

2. AIRBORNE AND AIRMOBILE OPERATIONS

Cuba has at least two airborne units: MINFAR's Assault and Landing Troops, which are organized into at least one brigade, and MININT's Special Troops. Both are small, well trained and highly motivated. They could be effectively employed in such operations as seizing either key targets in rear areas or lines of communications, or as the lead elements in amphibious operations. DAAFAR has limited airlift capabilities. The Assault and Landing Troops are subordinate to DAAFAR, but probably would come under the operational control of either the Minister of FAR or the army and/or corps commanders. Cuba has conducted airborne operations in its major exercises.

The FAR is also capable of conducting airmobile operations. The airmobile troops, which are a component of the Assault and Landing Troops, are subordinate to DAAFAR but also probably would come under the operational control of either the Minister of FAR or the army and/or corps commanders. The airmobile troops could be employed in the same type of operations as the airborne troops and, in addition, they could be used for reconnaissance and raiding missions behind the FEBA. Cuba has practiced conducting airmobile operations in several military exercises using armed Mi-4 HOUND and Mi-8 HIP helicopters. There are at least 12-Mi-8 HIPs which are configured as attack/antitank helicopters.

3. FIGHTING IN BUILT-UP AREAS

With the exception of a little urban fighting in Angola, the Cubans have had very little experience in combat in built-up areas. Fighting in built-up areas differs in several important respects from field combat. First, the fighting quickly becomes a series of small-scale battles at squad to company level, which often means that there is little central control. This forces small unit commanders to exercise a great deal of independence, which they are not trained to do. Second, the restricted space reduces the unit's ability to maneuver and restricts their observations and fields of fire. Third, the destruction and obstacles in urban areas make it very difficult to maintain rapid rates of advance and also increases the demands for ammunition. Fourth, effective reconnaissance of an urban area is often difficult to achieve, thus necessitating reconnaissance by fire. Within Cuba, the attacks and defenses of urban areas would be aided by government sympathizers.



Cuba has been increasing its airmobile capabilities. DAAFAR has some armed Mi-4 HOUND (shown) and Mi-8 HIP helicopters. It has at least 12 Mi-8 HIPs, each of which is armed with 6 antitank guided missiles and six 57-mm rocket pods.

a. *Attack*

The Cubans probably would prefer to avoid fighting in built-up areas, particularly in Cuba, because of the high civilian casualty rates. However, if the built-up area could not be bypassed, they would attempt to seize it. If a division is advancing rapidly, as it would be in movement to contact or in an exploitation of breakthrough, it probably will have an infantry battalion, strongly reinforced by engineers, tanks and artillery, several kilometers in front of the main body of the division. The mission of this battalion would be first to bypass and, failing that, to attempt to seize at least the outer perimeter of the town. If the town is defended, the leading regiment would be ordered to take the built-up area by attacking from the line of march. The storming, which exacts a high combat loss, usually is preceded by an intense artillery and/or air bombardment. If the attack fails, then the commander establishes a blockade and initiates preparations for a deliberate attack, which normally consists of several converging attacks initiated in different sectors of the town to split the enemy defense into several segments for subsequent piecemeal destruction. This attack also would be preceded by an intensive artillery and/or air bombardment.

The battalion's frontage in the attack is generally less than in field conditions. In a town, a battalion usually will attack in one echelon along several parallel streets over a frontage of approximately 300 to 400 meters. A company

usually attacks down one street. Engineers usually are attached to companies and platoons with the principal missions of clearing the approaches to the town, breaching minefields, clearing areas and fortifying them for command posts, and constructing obstacles to protect against counterattacks. Where possible, tanks lead dismounted infantry units into the town streets for mutual protection (figure 38). These units would be followed by a platoon with antitank weapons and mortars and then a fire support team. Figure 39 illustrates a reinforced motorized infantry company in an attack in a built-up area.

b. Defense

Within Cuba, the defense of built-up areas probably would be the primary responsibility of the less well-trained regular and reserve forces supported by significant numbers of personnel from the EJT and Civil Defense military units. The best-trained units would probably be used to defend only the built-up areas which the Cubans consider to be critical.

Far fewer troops are needed to defend a town or city than to seize it. A company can defend a sector up to 600 meters wide and would create strong points in key buildings manned by platoons. Defensive combat techniques are the same as those used in the offensive, although more rear and engineer support are required. Patrols and ambushes probably would be used. If there is sufficient time available, radio and line command and control communications can be organized.

The defense of a town or city is organized for all-round defense based on outer and inner defense zones. The outer, or first echelon, would be established within or near the buildings on the edge of the town or city. The inner, or second echelon, would consist of strong points and alternative sites positioned to halt an enemy breakthrough. The first priority of the defending units is to destroy infantry who accompany tanks, because without the infantry, the tanks are much easier targets. Tanks used in the defensive would be utilized as platoon strong points.

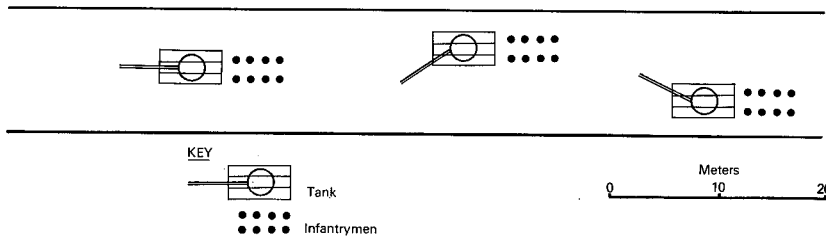

Figure 38. Combined Tank-Infantry Unit Proceeding Down a Street.

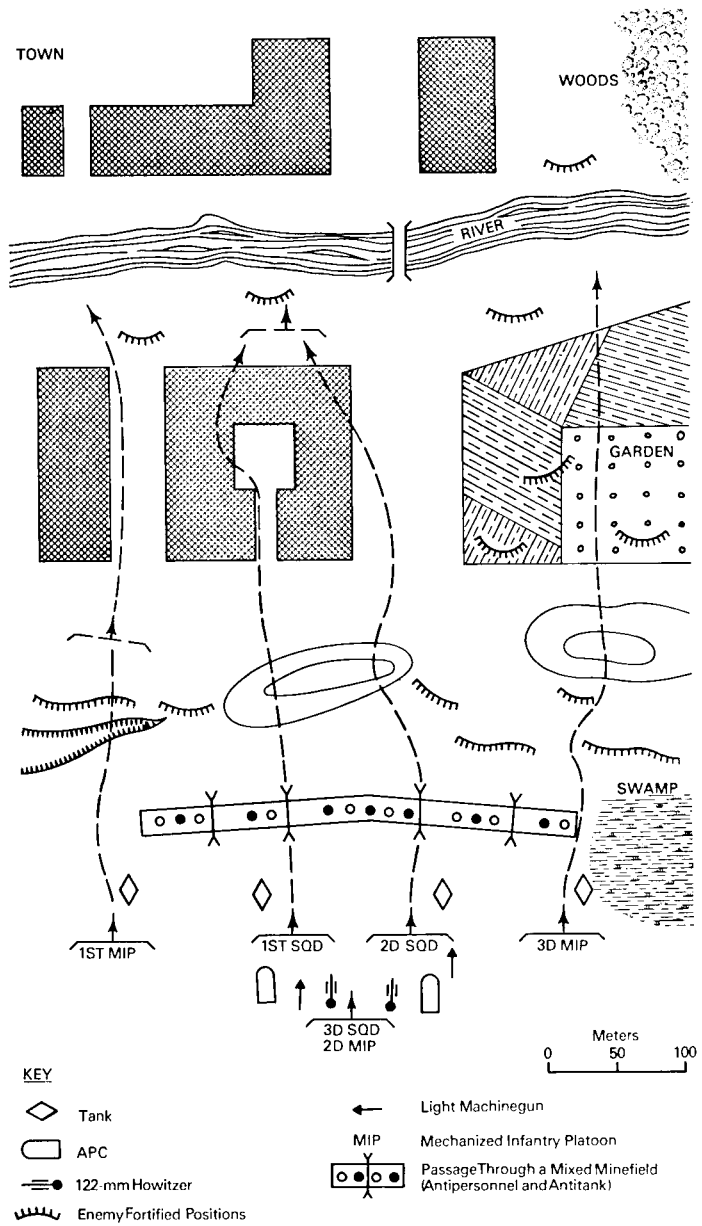

Figure 39. The Reinforced Motorized Infantry Company in the Attack in a Built-up Area.

4. MOUNTAIN WARFARE

Although Cuba has only three small mountain systems (discussed in this chapter, section A), the mountains have played an important role in Cuban revolutionary history. In December 1956, Fidel Castro and his band took refuge in the Sierra Maestra in southeastern Cuba, and from there launched their successful revolution. Between 1959 and 1965, anti-Castro bands fought in the Escambray Mountains in central Cuba. They were opposed by units known as "Fight Against the Bandits," composed of MINFAR and MININT personnel. The Cubans reportedly still have specially trained units known as "Mountain Troops" stationed in hilly areas throughout Cuba.

a. *The Offensive*

The usual type of offensive maneuver is a frontal attack on the enemy with regiment- or, more likely, battalion-size units operating on independent axes along roads, valleys and ridges in conjunction with enveloping movements across adjacent mountains. Enveloping forces are employed to seize commanding heights, passes and road intersections on the flanks and rear of the enemy position while the main force carries out the frontal attack. If the enveloping forces succeed in making the enemy withdraw before the main frontal attack is initiated, the main force will immediately carry out a pursuit to prevent the enemy from occupying another defensive position. The Cubans would also probably deploy highly trained, small unit mountain troops for reconnaissance.

b. *The Defense*

The defense is organized as a series of strong points on the commanding heights, each mutually supporting and capable of all-round defense. Gaps are covered by patrols. In the event of strong points being surrounded, they will continue to fight without any thought of withdrawal. Constant observation and patrollings are carried out to prevent outflanking movements.

c. *Fire Support*

Fire support for Cuban forces in mountainous country does not differ greatly from the support afforded in offensive and defensive operations under normal terrain conditions.

d. *Armor*

Every effort is made to employ tanks in areas where the enemy will not expect them; in the defense, tanks are sometimes deployed in forward infantry strong points.

5. JUNGLE WARFARE

Since Cuba has very little jungle-like conditions, the principal jungle experience has been gained in northern Angola. Probably, Cuba's highly trained "Mountain Troops" (discussed above) could best adapt to fighting in jungle conditions.

The jungle, especially mountainous terrain, has a leveling effect on the relative capabilities of opposing forces since it limits sharply the employment of armor, heavy artillery, and vehicular traffic, and also restricts aerial observation.

Under such conditions, the Cubans would resort to tactics utilizing full advantage of natural cover, extensive use of infiltration, ambushes and guerrilla warfare, secrecy and speed of movement, continuous reconnaissance, and well-coordinated planning. The jungle conditions would make it difficult to utilize large units and would also complicate commanders' control over their own and subordinate units.

6. GUERRILLA WARFARE

Cubans undoubtedly would use guerrilla warfare tactics extensively, particularly in defending their island. The guerrilla troops would continue to fight even if the government were defeated. These forces, which would include some of the most dedicated and motivated personnel, would have the advantage of being very knowledgeable about the terrain and population. The largest tactical units probably would be of battalion-size, although company- and platoon-size units probably would be the principal attacking forces, particularly for hit-and-run raids. The forces would try to avoid defensive battles.

Section G--Naval Tactics

The Cuban Navy (MGR) is essentially a defensive force and has a very limited transport capability; its primary mission is the protection of the island against seaborne assaults. It has had a very restricted role in Cuba's deployment of forces overseas. The MGR has sufficient naval combatants and skilled personnel to counter all except large-scale naval attacks.

If Cuba were assaulted by sea, naval coastal surveillance units would help to locate the attacking forces. The Border Guard Troops (TGF) would supplement the MGR with additional personnel and small craft. The MGR probably would employ an in-depth defense with three of its principal weapons systems: the SAMLET cruise missiles, the Missile Attack Boats, and the Small Torpedo Boats.

The SAMLETs, which are believed to be deactivated, probably would be used to attack enemy ships out to their range of about 80 kilometers if they could be activated in time. Even if they were activated, the SAMLETs probably would not be very effective against a modern naval task force because of the age of the SAMLET's electronics.

The Missile Attack Boats, consisting of OSA-Is, OSA-IIs, and KOMARs, are Cuba's most effective deterrent. They most likely would operate within the range of the SAMLET's 80-kilometer radius, although they may also be deployed beyond the SAMLET's radius. The boats probably would also be protected to the extent possible by close air support and coastal artillery. The boats, deployed in squadrons, are armed with antiship SS-N-2 STYX surface-to-surface missiles, which have a range of approximately 40 kilometers.

The Torpedo Boats, consisting of P-4s and P-6s, would be reinforced by the TURYAs. They probably would be deployed closer to shore than the Missile Attack Boats. Their principal weapons systems, the torpedos, probably would have limited effectiveness against a modern navy.

The approximately 14 Submarine Chasers would be relatively ineffective. Their submarine detection equipment is old and would not be effective against present countermeasures. The ships also lack a strong offensive capability. They could possibly serve as a last line of defense with the TGF craft. Cuba's single FOXTROT Attack Submarine is vulnerable to ASW measures of a sophisticated navy.

CHAPTER 6 UNIFORMS, INSIGNIA AND AWARDS

Section A—Uniforms and Insignia

1. BACKGROUND

The austere uniform consisting of an olive-green shirt, trousers and field cap adopted for wear on all occasions by members of the Cuban FAR immediately after the Revolution has been replaced by a number of conventional uniforms styled along Soviet lines. The new uniforms also resemble those of other Latin American countries.

New uniform regulations became effective on 2 December 1976, authorizing some 20 different uniforms for all services. A new military rank system, considerably altering the previous standard rank insignia, also became effective. And, finally, the December 1976 regulations authorized 23 new branch and service insignia.

All armed forces personnel, with the exception of some navy enlisted members, wear the same basic style of uniform. The major differences are in material and color. Ground forces uniforms are basically olive drab, air force personnel wear blue, and the naval uniforms are blue-black. Summer uniforms are worn from 16 March to 15 November; winter uniforms are worn the rest of the year. This may vary in some localities due to seasonal periods; changes are authorized by the major regional commanders.

Rank is denoted by using various sizes and numbers of stars for the officers and stripes for enlisted personnel. Branch of service is indicated by the use of colored piping on the shoulder boards and cap bands, collar tabs, and metallic insignia.

Uniforms and insignia are shown in figures 40 through 54.

2. GROUND FORCES UNIFORMS

There are four basic types of ground forces uniforms: (a) parade, including (b) ceremonial parade—for formal reviews, special military occasions, state occasions, and official visits of foreign dignitaries; (c) service—for duty, but also worn during off-duty hours; and (d) field—for training, maneuvers, exercises, and unit line duty.

a. *Male Officers*

Male ground forces officers wear several types of parade uniforms (figure 40). Each consists primarily of an olive-drab coat and trousers, white shirt, dark tie, brown leather belt and shoulder harness, white gloves, service cap, and black shoes. The ceremonial parade uniform, worn only by personnel of the Honor Guard Unit and the General Staff Band, is of the same style as the parade

uniform except that it has red collar tabs, red piping on the sleeves, red stripes on the sides of the legs, and a gold belt in place of the brown leather belt and shoulder harness.

Several versions of the service uniform are similar to the conventional US Army green uniform. The primary differences are in tailoring. One style (figure 40) consists of an olive-drab coat or jacket and trousers, light-colored shirt, dark tie, service cap with visor, and black shoes. Another type (figure 41) calls for a waist-length light-green open-collar shirt-jacket, olive-drab trousers, service cap with visor, and black shoes. A fur cap with earflaps and a full-length double-breasted overcoat complement the service uniform during visits to cold climate areas (figure 41).

Field uniforms consist of an olive-green shirt and trousers, belt, helmet or soft cap, and boots or low quarters (figure 41).

b. *Female Officers*

The parade uniform (figure 40) consists of an olive-drab coat and knee-length skirt, white blouse with a black necktab, olive-drab beret with short visor, and black loafer-type shoes. Female officers apparently do not have ceremonial parade uniforms.

Two service uniforms (figure 41) have been observed. One consists of an olive-drab jacket and skirt, light-green shirt with an olive-drab necktab, olive-drab beret with short visor, and black shoes. The other is a light-green shirt-jacket, olive-drab skirt, no headgear, and black shoes.

The field uniform (figure 41) is the same as that worn by the male except that generally the female wears neither belt nor headgear.

c. *Male Enlisted*

The parade uniform is authorized for career personnel who reenlist after completing their obligatory service and for warrant officers. There are variations in the parade uniforms (figure 42). One version consists of an olive-green shirt and trousers, white belt and shoulder harness, helmet, and black combat boots. The trousers are bloused and tucked into the boots. Career personnel wear inverted chevrons of gold braid on the lower part of the left sleeve. The ceremonial parade uniform is similar to that worn by officers except that it has a white belt and shoulder harness in place of the gold belt.

The enlisted service uniform (figure 42) is worn both on and off duty. It consists of an olive-green shirt-jacket and trousers, olive-green soft cap with visor, and black shoes. A short-sleeve shirt-jacket may be substituted for the long-sleeve version.

The enlisted field uniform (figure 42) is similar to that of the officers. The uniform illustrated with the olive-green helmet and accouterments is authorized for career personnel only.

d. *Female Enlisted*

The parade uniform for enlisted females is similar to that for officers as illustrated in figure 40. Ceremonial parade uniforms have not been observed on enlisted female personnel.

The service uniform (figure 42) consists of an olive-green coat and knee-length skirt, no headgear, and black shoes. It is similar to the green cord uniform worn by female members of the US Army.

Field uniforms (figure 42) are the same as those authorized for female officer personnel except that the shirt is tucked into the trousers.

3. AIR FORCE UNIFORMS

There are four basic types of air force officer uniforms: (a) parade, including (b) ceremonial parade—for reviews, special military occasions, and official visits of foreign dignitaries; (c) service—for duty; and (d) field—for training and work details. Air defense and enlisted air force personnel probably wear uniforms like those worn by members of the ground forces.

a. *Male Officers*

The air force officers have two parade uniforms (figure 43). One consists of a blue coat and trousers, white shirt, black tie, blue service cap with visor, and black shoes. The other is the same except that a gold belt and aiguillette and white gloves are added.

The service uniform (figure 43) is similar in color and style to one of the ground forces versions. It consists of an open-collar olive-green shirt-jacket, olive-drab trousers, blue-banded service cap, and black shoes (figure 43).

The air force field uniform is the same as that for the ground forces (figure 41).

b. *Female Officers*

Women in the air force are known to have only two uniforms. The parade uniform (figure 43) is similar to its ground forces counterpart except that it is blue instead of olive drab.

The field uniform (figure 43) consists of a blue shirt and trousers, blue beret with short visor, and black shoes.

4. NAVY UNIFORMS

There are three basic types of navy uniforms: (a) parade—for formal reviews, special military occasions, state occasions, and official visits of foreign dignitaries; (b) service—for duty and informal social occasions; and (c) work—for training and work details.

a. *Male Officers*

The winter parade uniform consists of a blue-black double-breasted coat and trousers, white shirt, black tie, white service cap with visor, and black shoes. The accouterments worn with this uniform are a gold belt and aiguillette and white gloves. Two parade uniforms are authorized for summer wear. Each consists of a white coat, one with four pockets and the other with two, white trousers, white shirt, black tie, white service cap with visor, and black shoes. Gloves are optional. (Figure 44.)

The two service uniforms worn during the winter period are the same except that one has a waist-length jacket in lieu of a coat. Each consists of a blue-black coat or jacket and trousers, white shirt, black tie, white service cap with visor, and black shoes. One of the two service uniforms worn during the summer season is distinctly Soviet in appearance. It consists of a beige shirt-jacket, blue-black trousers, white service cap with visor, and black shoes. The other uniform is a white shirt, trousers and service cap with visor, and black shoes. (Figure 44.)

The work uniform consists of an olive-green short-sleeve shirt and trousers, olive-green garrison cap, and black shoes (figure 44).

b. *Female Officers*

The winter parade uniform consists of a blue-black coat and knee-length skirt, white blouse, blue-black beret with a short visor, and black loafer-type shoes. The summer parade uniform is identical to the winter uniform except that it is all white, including the beret and shoes. A dark necktab is worn with both uniforms. (Figure 45.)

The winter service uniform consists of a blue-black coat and knee-length skirt, white blouse, black tie, and black shoes. The summer service uniform includes a beige open-collar shirt-jacket, knee-length blue-black skirt, and black shoes. Headgear is not worn with either of these uniforms. (Figure 45.)

Female officers have not been seen in work uniforms.

c. *Male Enlisted*

The parade uniform (figure 46) consists of a white jumper tucked into blue-black trousers, white round cap, black belt, and black shoes.

Winter and summer service uniforms (figure 46) are patterned after the traditional sailor's uniforms. Differing only in color, the winter uniform is predominantly blue-black and the one for summer is white.

The work uniform (figure 46) consists of an olive-green shirt and trousers, garrison cap, and black boots. Variations of this uniform include a blue and white striped long/short sleeve shirt, black shoes or tennis shoes.

The marines' parade uniform (figure 46) consists of a blue-black shirt-jacket with an open collar and two pockets worn over blue-black trousers bloused into black boots. The uniform includes a black beret, white belt and white gloves.

d. *Female Enlisted*

Only two uniforms, both summer service type, have been observed for enlisted females (figure 46). The first consists of a white coat, skirt and blouse, black tie, and black shoes (no headgear). The second is the same as the open-collar olive-drab service uniform without headgear authorized for women in the ground forces.

5. SPECIAL UNIFORMS

a. *Paratroopers* wear a green and brown camouflage coverall, with black boots and a helmet (figure 47).

b. The uniform for *MININT Special Troops* is the same as that for paratroopers except that a black beret replaces the helmet.

c. *Chemical warfare* gear includes a green rubberized one-piece protective suit, protective mask, gloves, and rubber boots (figure 47).

d. Two types of field uniforms are worn by *tankers* (personnel assigned to tank units). One is an olive-green coverall and the other is similar to the ground forces field uniform. A tanker's helmet is worn with both uniforms (figure 47).

e. Three varieties of *pilot* uniforms have been observed: conventional, antigravity, and pressurized (figure 47).

f. The *ground and Air Force cadet* uniform consists of an olive-green coat and trousers, green shirt, black tie, service cap, and black shoes (figure 48).

g. *Naval cadets* wear a white double-breasted coat, with a standup collar, blue-black trousers, white service cap, black belt and black shoes (figure 48).

h. *Militiamen* wear a light-gray coat, olive-green trousers, light shirt, dark tie, service cap with visor, white belt and shoulder harness, and black shoes (figure 47). *Militiawomen* wear the same style and color uniform with a beret but without the belt and shoulder harness (figure 48). A knee-length skirt may be worn in lieu of the trousers.

i. The uniform worn by *MININT Border Guards* consists of a beige shirt, olive-green trousers, a campaign-style hat, and black shoes (figure 48).

6. INSIGNIA

Military personnel wear a variety of insignia to indicate rank, branch of service, and specialty. Table 2 (chapter 2), table 5 (chapter 3) and table 6

(chapter 4) present Cuban ranks in Spanish, a literal translation, and approximate US equivalents. Insignia of rank in this chapter are given in approximate US equivalents.

a. *Rank Insignia*

Officer ranks for all services are indicated by varying the number and size of stars that are displayed on Soviet-patterned shoulder boards. The shoulder boards are basically olive green with red longitudinal stripes for the ground forces (figure 49) and with blue stripes for the Air Force (figure 50). The rank of General of the Army, held by Fidel Castro, is denoted by a large silver star on a diamond-shape background which is half red and half black. General and flag officers display crossed olive and laurel branches in gold on the shoulder end of the shoulder board. Navy shoulder boards are gold color with black longitudinal stripes (figure 51) and ranks are similar to the other two services except that flag rank stars have a red center and black background.

On 28 July 1978, the regulations in effect since December 1976 were amended: stars were substituted for chevrons in the junior grade officer rank insignia for all services.

These new regulations added another rank, that of chief warrant officer, to the warrant officer (sub-official) class for the three services. Warrant officer insignia are displayed by small stars on olive-green shoulder boards with red piping for ground forces, blue piping for the air force, and black piping on gold colored shoulder boards for the navy. One to four gold stripes on olive-green shoulder boards or, for career personnel, on tan shoulder boards denote ground and air forces enlisted ranks. The initials FAR are displayed on the shoulder end of the shoulder board. Navy enlisted ranks are similar except that the stripes are yellow on blue-black shoulder boards and the FAR initials are omitted.

b. *Branch of Service Insignia*

Branch of service insignia is worn on the collar tabs by general and senior officers, on the shoulder boards and on the cap band by other officers, and on the left shirt sleeve and on the semisoft caps of enlisted personnel. National emblems are worn on service caps, lapels, and belt buckles (figures 49, 50, 51 and 52).

c. *Specialties*

Sleeve patches are sometimes worn to indicate service specialties (figure 51). One patch, identified as that worn by General Military Service (SMG) personnel, is a shield-shaped shoulder patch with diagonal blue and white stripes, the initials FAR in white on a red background, and the numeral 1, 2, or 3 indicating the years of service. Air force rated officers have been observed wearing pilot wings with the initials FAR displayed below the insignia, above the right breast pocket. The Combined Arms Specialist Badge is awarded to officer and enlisted personnel who have successfully completed a series of proficiency tests. These badges are awarded in Master, 1st, 2d, and 3d class. Only officers

and career enlisted personnel are eligible to receive the Master class. This badge is worn above the right breast pocket.

Section B—Awards and Decorations

After Castro seized power in January 1959, the laws establishing Cuban awards and decorations were abrogated. Some of the invalidated decorations, however, were later reinstated and new ones were introduced. These more recent decorations for military personnel are merit awards for training or achieving goals rather than awards for combat action or heroism.

The following is the most current available information on Cuban awards and decorations.

National Order of Merit Carlos Manuel de Cespedes. Awarded in six classes to Cuban and foreign military and civilian personnel for outstanding service to the nation or to mankind and for contributions to the arts, letters, and science (figure 53).

Jose Marti National Order. Awarded to foreign heads of state and political leaders who have distinguished themselves through their solidarity with the struggle against imperialism, colonialism and neocolonialism and by their support of the Cuban Socialist Revolution (not illustrated).

National Order Playa Giron (Bay of Pigs). Awarded to Cuban and foreign military and civilian personnel for outstanding participation in the struggle against imperialism or colonialism and for extraordinary deeds contributing to peace and to the progress of humanity (not illustrated).

Twentieth Anniversary Commemorative Medal. Awarded to individuals of international fame in the arts and sciences who have expressed their solidarity with the Cuban cause, to Cubans who have demonstrated their solidarity with other peoples in need, and to persons who have contributed to the development and to the defense of the Socialist Fatherland (not illustrated).

Twentieth Anniversary of the Revolutionary Armed Forces Commemorative Medal. Awarded to Cuban and foreign military personnel, to members of the Youth Labor Army and Interior Ministry, to those who took part in the *Granma* expedition, and to peasants who aided the Rebel Army (figure 53).

Revolutionary Armed Forces Vanguard Merit Awards. Consisting of at least 15 different badges, these awards are issued to military personnel and units, armed forces civilian employees, and military school students who have earned an outstanding rating in socialist emulation. Three types are issued to commanders, officers, and enlisted personnel; the 12 remaining types are unit badges. It is believed that five different badges may be awarded to ground force units from platoon through army; four to the navy units from platoon level through squadron; and three to DAAFAR units (figure 54).

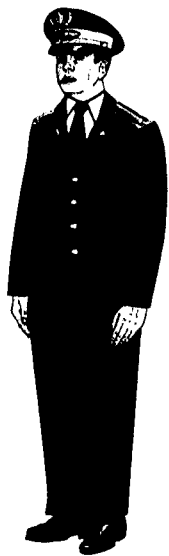

PARADE
UNIFORM



PARADE
UNIFORM

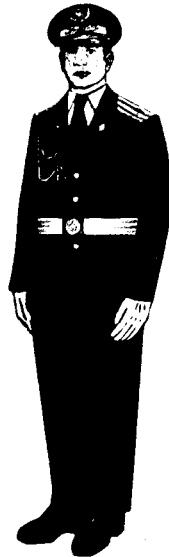

CEREMONIAL
PARADE UNIFORM



PARADE
UNIFORM



SERVICE
UNIFORM

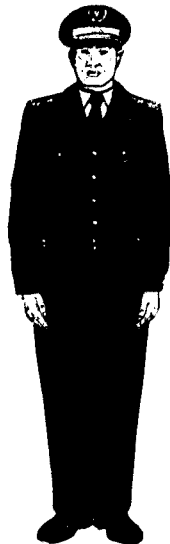

SERVICE
UNIFORM

Figure 40. Ground Forces and Air Force Officers Uniforms.

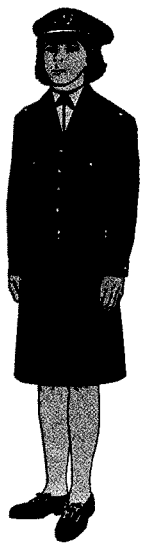

SERVICE UNIFORM

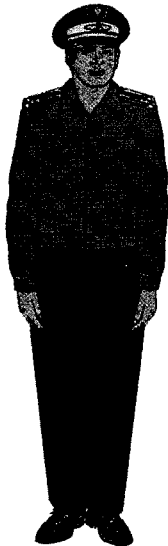

SERVICE UNIFORM



SERVICE UNIFORM

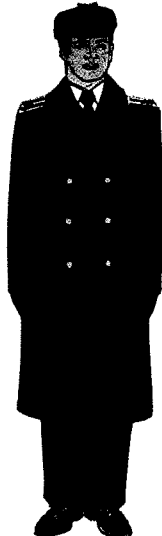

SERVICE UNIFORM

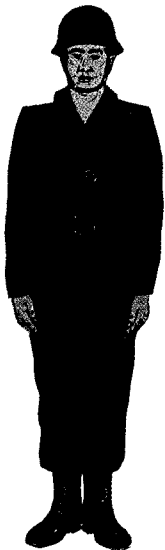

FIELD UNIFORM



FIELD UNIFORM



FIELD UNIFORM

Figure 41. Ground Forces and Air Force Officers Uniforms.

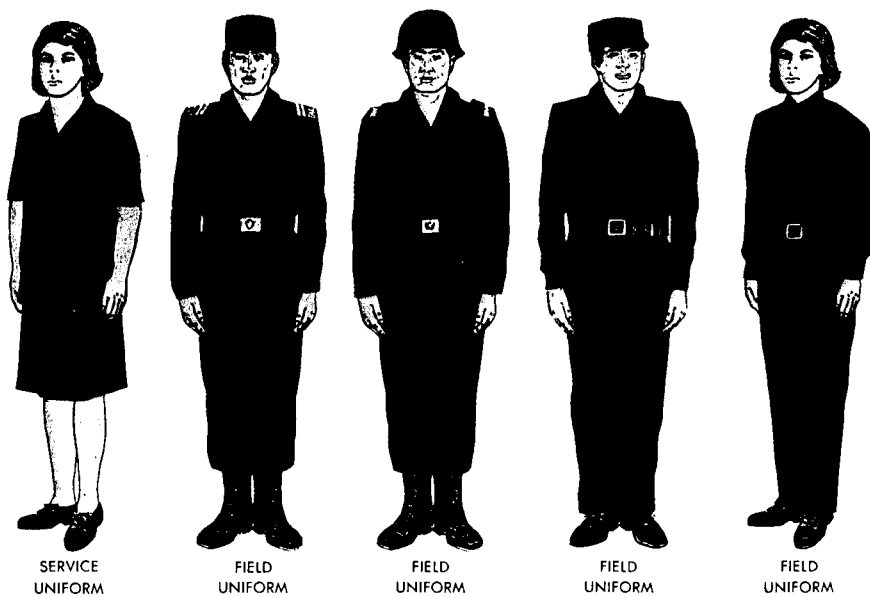
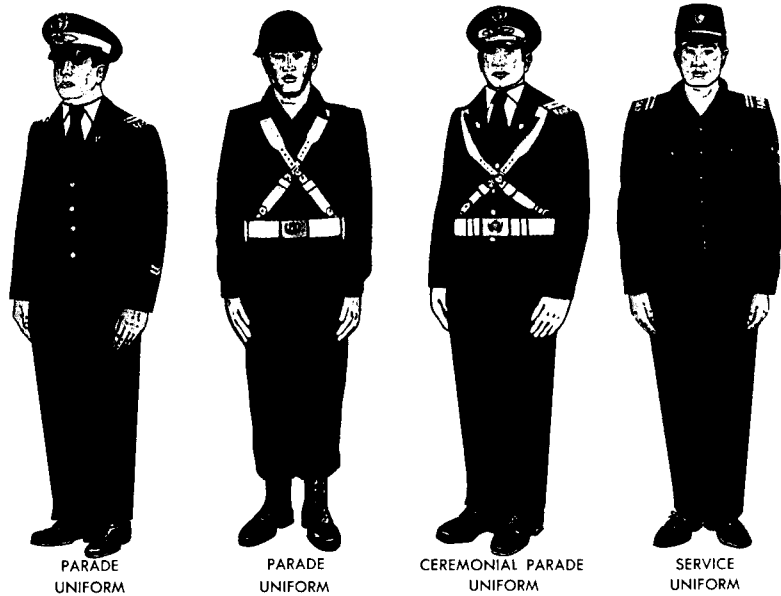
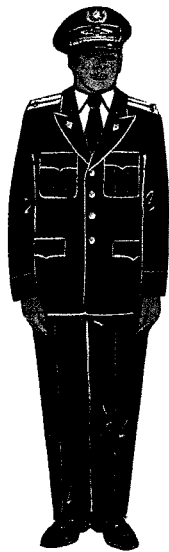

Figure 42. Ground Forces and Air Force Enlisted Uniforms.



PARADE
UNIFORM



PARADE
UNIFORM



PARADE
UNIFORM

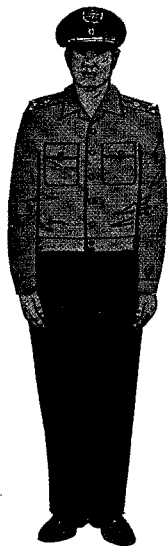

SERVICE
UNIFORM



FIELD
UNIFORM

Figure 43. Air Force Officers Uniforms.



WINTER PARADE UNIFORM

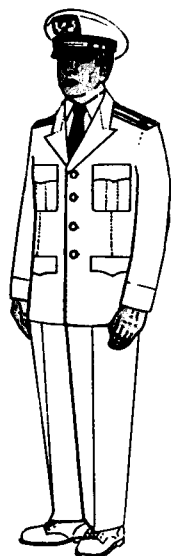

SUMMER PARADE UNIFORM

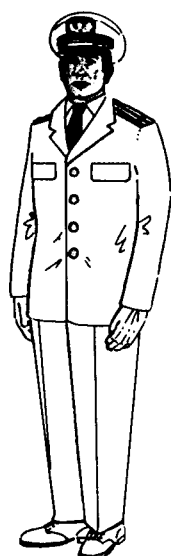

SUMMER PARADE UNIFORM

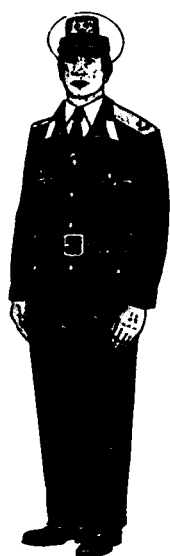

WINTER SERVICE UNIFORM

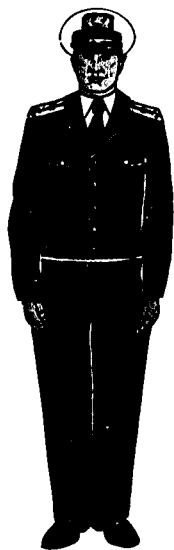

WINTER SERVICE UNIFORM



SUMMER SERVICE UNIFORM

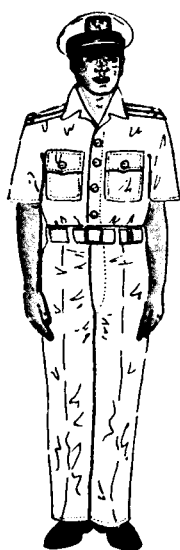

SUMMER SERVICE UNIFORM

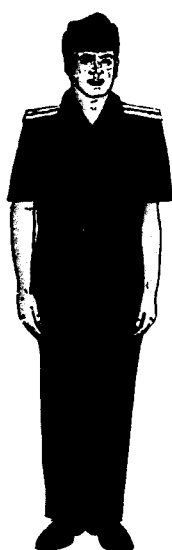

SUMMER WORK UNIFORM

Figure 44. Naval Officers Uniforms.



WINTER PARADE
UNIFORM

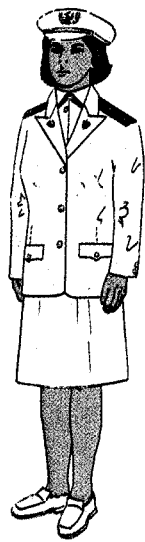

SUMMER PARADE
UNIFORM



WINTER SERVICE
UNIFORM



SUMMER SERVICE
UNIFORM

Figure 45. Naval Officers Uniforms.

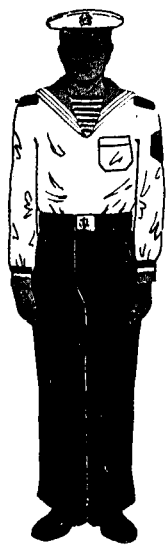

PARADE
UNIFORM

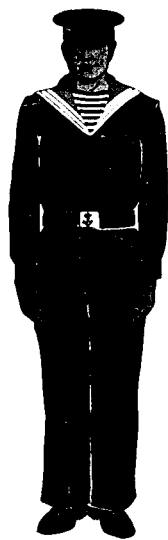

WINTER
SERVICE OFF DUTY
UNIFORM

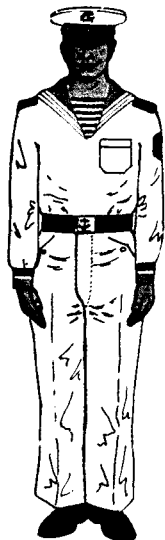

SUMMER
SERVICE OFF DUTY
UNIFORM



SUMMER SERVICE
UNIFORM



MARINE
PARADE UNIFORM

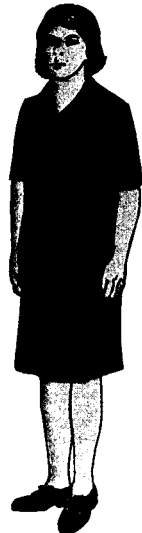

SUMMER SERVICE
UNIFORM



WORK
UNIFORM



WORK
UNIFORM

Figure 46. Naval Enlisted Uniforms.

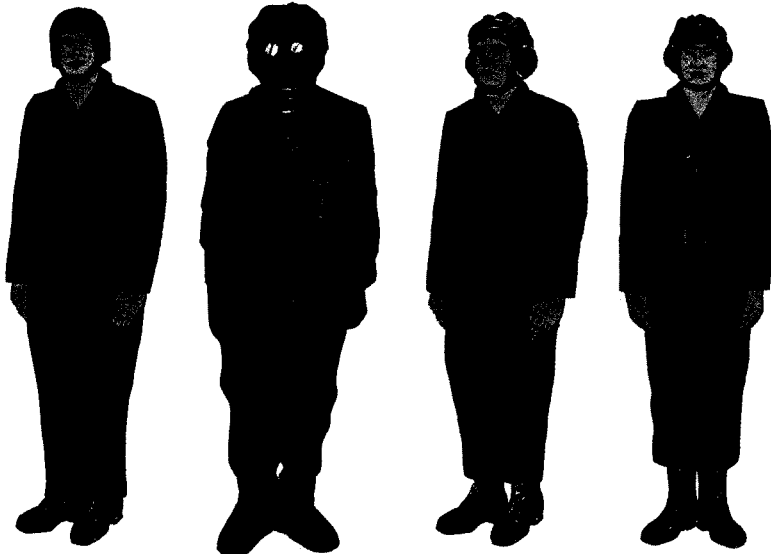

PARATROOPER
UNIFORM

CHEMICAL WARFARE
UNIFORM

TANKER
UNIFORM

TANKER
UNIFORM



PILOT UNIFORM
(CONVENTIONAL)



PILOT UNIFORM
(ANTIGRAVITY)



PILOT UNIFORM
(PRESSURIZED)

Figure 47. Ground Forces and Air Force Special Uniforms.

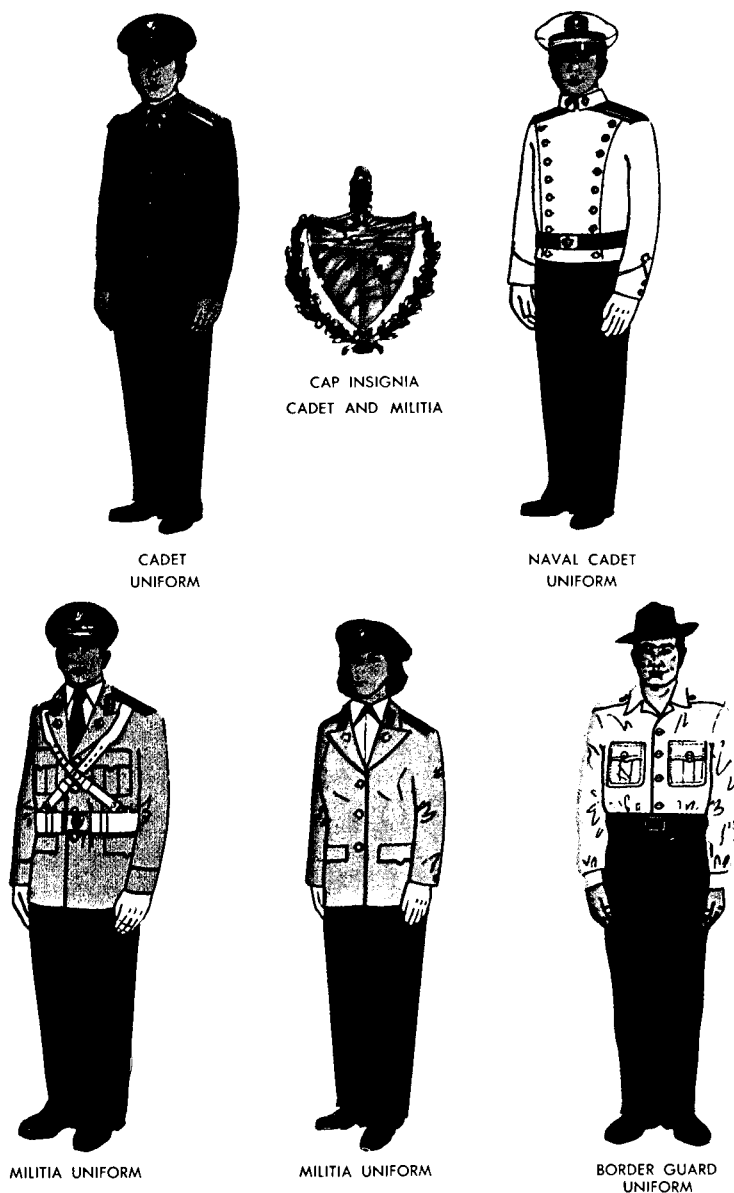
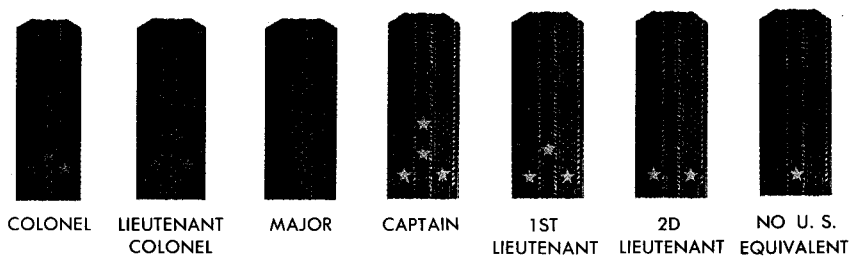
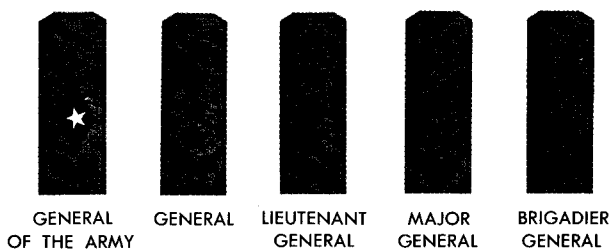

Figure 48. Cadet and Paramilitary Uniforms and Insignia.

OFFICERS



WARRANT OFFICERS AND ENLISTED MEN

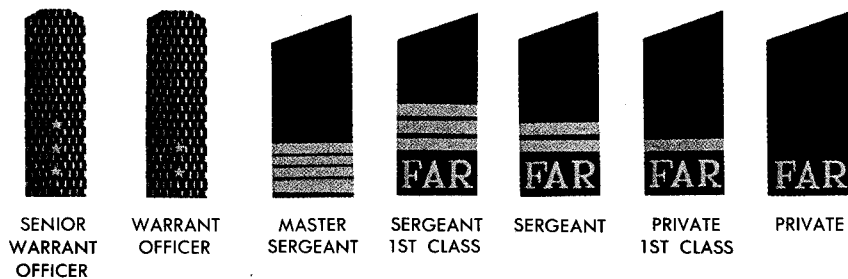

Figure 49. Ground Forces Officers, Warrant Officers and Enlisted Rank Insignia.

OFFICERS



GENERAL OF THE AIR FORCE



GENERAL



LIEUTENANT GENERAL



MAJOR GENERAL



BRIGADIER GENERAL



COLONEL



LIEUTENANT COLONEL



MAJOR



CAPTAIN



1ST LIEUTENANT



2D LIEUTENANT



NO U. S. EQUIVALENT

WARRANT OFFICERS AND ENLISTED MEN



SENIOR WARRANT OFFICER



WARRANT OFFICER



SENIOR MASTER SERGEANT



MASTER SERGEANT



STAFF SERGEANT



AIRMAN 1ST CLASS



AIRMAN

Figure 50. Air Force Officers, Warrant Officers and Enlisted Rank Insignia.

OFFICERS

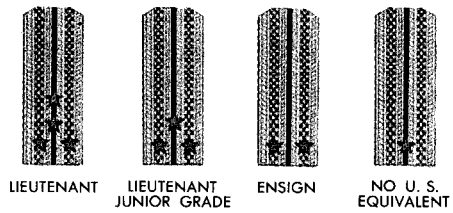
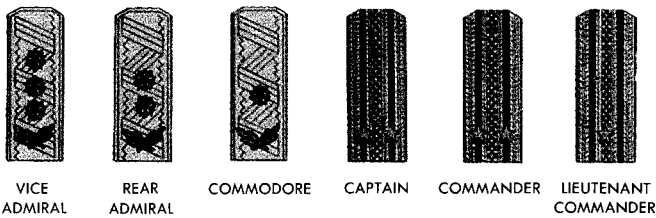

WARRANT OFFICERS AND ENLISTED MEN

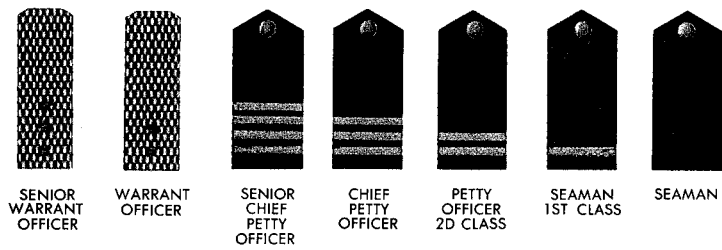

CAP INSIGNIA OFFICERS



CAP INSIGNIA ENLISTED



ENLISTED CAP BAND

Figure 51. Naval Officers, Warrant Officers and Enlisted Rank and Cap Insignia.

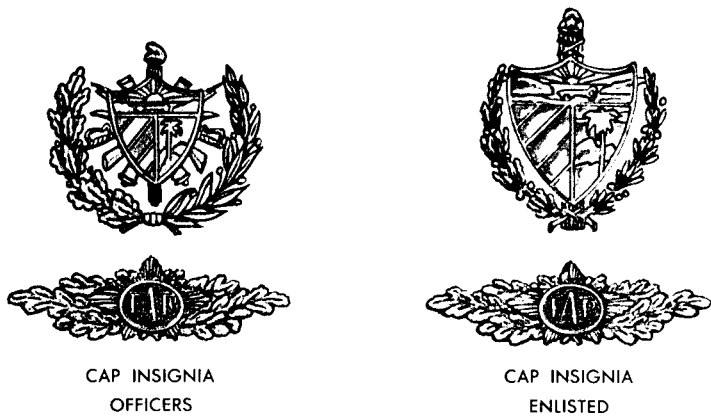
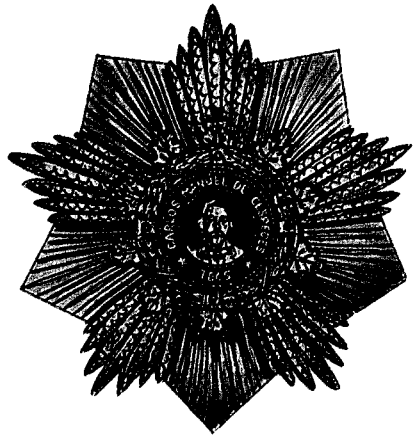

Figure 52. Ground Forces and Air Force Insignia.



NATIONAL ORDER OF MERIT
CARLOS MANUEL DE CESPEDES



TWENTIETH ANNIVERSARY
OF THE REVOLUTIONARY
ARMED FORCES
COMMEMORATIVE MEDAL

Figure 53. Decorations.

JEFE VANGUARDIA FAR
EMULACION SOCIALISTA



SOCIALIST EMULATION
(COMMANDERS)



SOCIALIST EMULATION
(OFFICERS)



VANGUARD
(ENLISTED)



VANGUARD
(ARMY)



SOCIALIST EMULATION
(PLATOON)



OUTSTANDING SERVICE
(ARMY)

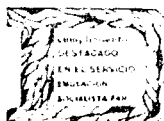

OUTSTANDING SERVICE
IN SOCIALIST EMULATION

Figure 54. Revolutionary Armed Forces (FAR) Vanguard Merit Awards.

Appendix A

ORGANIZATION OF A REPRESENTATIVE ARMY

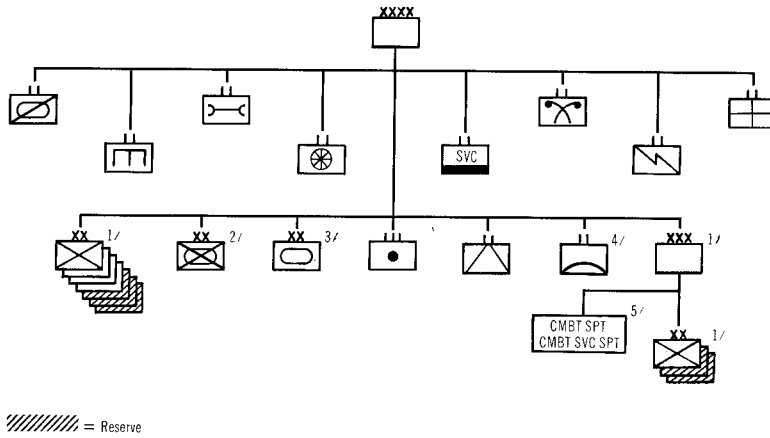

- 1/ Number of divisions in armies and corps vary; the number of corps also vary.
- 2/ Not all armies have a mechanized infantry division.
- 3/ Not all armies have an armored division.
- 4/ Probably a Category II or III unit.
- 5/ Corps have the same combat support and combat service support units as an army. These units are staffed at levels consistent with the number of divisions they support.

TABLE OF PERSONNEL AND MAJOR EQUIPMENT

Personnel/Equipment	Total Army	Armd Recon Bn	Engr Bn	Maint Bn	Trnsp Bn	Svc Bn	Chem Def Bn	Sig Bn	Med Bn	Seven Inf Div (Total)	Mech Inf Div	Armd Div	Arty Reg	Anti-tank Bn	ADA Bn	Corps
Total Personnel	71,500	350	X	300	X	X	X	250	200	32,200	8,200	5,200	975	200	X	17,300
Mortars	408+									252	36-54	12-18				108
Self-propelled/Towed ADA Guns	X									X	48+	30+	X		X	X
Antitank Guided Missiles on BRDMs	X	X								X	X	X				
Medium Tanks/SU-100 Assault Guns	460+									X	126+	116+				X
PT-76 Light Tanks	45+	X								21	12+	12+				X
Light (Antitank) Guns	546+									300+	30	22	18	X		198
Medium/Heavy Guns/Howitzers	208+									100+	18-36	18-24	18			54
Multiple Rocket Launchers	208+									100+	18	18	18			54
Armored Recon Vehicles	X	X	X				X			X	X	X	X			X
Armored Personnel Carriers	X	X	X				X			X	X	X	X			X

X - Specific data not available.

Appendix B

ORGANIZATION OF A REPRESENTATIVE INFANTRY DIVISION^{1/}

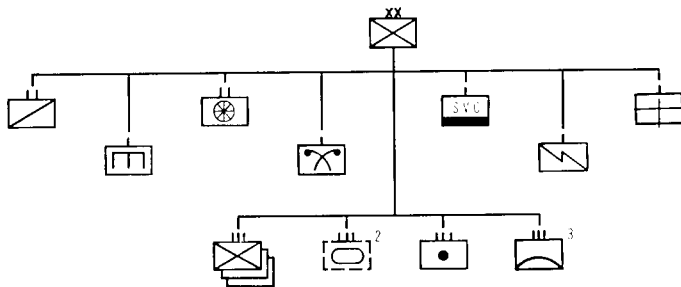

- 1/ Regular infantry divisions are composed primarily of Category I units.
- 2/ Probably does not exist in most regular infantry units. Does not exist in any reserve divisions.
- 3/ ADA equipment probably is Category III unit. Manning and equipment require to the ADA elements vary greatly from division to division. Maximum strength is 600 with four firing batteries and no battalions.

TABLE OF PERSONNEL AND MAJOR EQUIPMENT

Personnel/Equipment	Total Inf Div	Recon Bn	Chern Def Co	Eng Co	Truce Bn	Suppl. & Ser Co	Sig Co	Art Co	Total Inf Regt	Inf Regt	Art. Regt	ADA Regt
Total Personnel	5,900	200	X	X	X	X	X	X	6,037	720	975	600
Machineguns	X	X							X	X		
RPG 7 Anti-tank Grenade Launchers	X	X							X			
82/120 mm Mortars	36								36			
Airborne Craft MGs - Towed ADA Guns	24+								18		6	X
Medium Tanks - SU-100 Assault Guns	65									65		
PT 76 Light Tanks	3									3		
Light (Anti-tank) Guns	48								36		18	
Medium/Heavy Guns - Howitzers	18										18	
Multiple Rocket Launchers	18										18	
Bridging Equipment	X			X						X		
Mine Clearing Devices	X			X						X		
Motocycles w. Sidecars	X	X							X	X	X	X
Armored Recon Vehicles	X								X	X	X	
Armored Personnel Carriers	X								X	X	X	

X - Specific data not available

Appendix C

ORGANIZATION OF A REPRESENTATIVE INFANTRY REGIMENT^{1/}

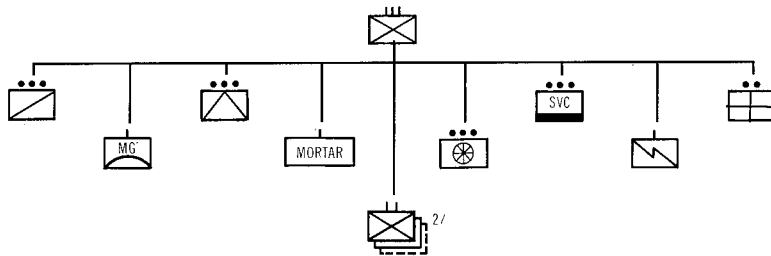

----- = possible

1/ Regular infantry regiments are composed primarily of Category I units. Reserve infantry regiments are a mixture of Categories II and III units.
 2/ If present, may exist as a Category III unit. Not counted in strength total.

TABLE OF PERSONNEL AND MAJOR EQUIPMENT

Personnel/Equipment	Total Inf Reg	Recon Plt	AAMG Co	Anti-tank Plt	Mort Btry	Trnsp Plt	Supply & Svc Plt	Sig Co	Med Sec	Two Inf Bn (Total)
Total Personnel	1,010	X	X	X	X	X	X	X	X	720
Machineguns	X	X								X
RPG-7 Antitank Grenade Launchers	X	X								X
Antiaircraft MGs	6		6							
57/76-mm Light (Antitank) Guns	6			2						4
82/120-mm Mortars	18				6					12
Motorcars w/Sidecars	X	X								
Armored Recon Vehicles	X									X
Armored Personnel Carriers	X									

X - Specific data not available.

Appendix D

ORGANIZATION OF A REPRESENTATIVE INFANTRY BATTALION^{1/}

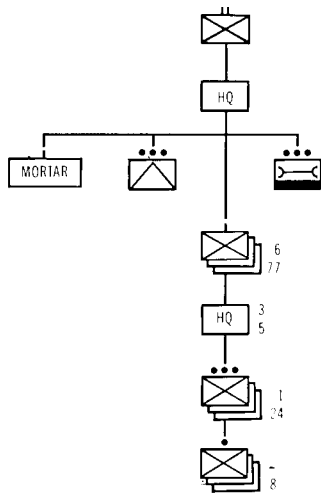

1/ Regular infantry battalions are composed primarily of Category I units. Reserve infantry battalions are a mixture of Categories II and III units.

TABLE OF PERSONNEL AND MAJOR EQUIPMENT

Personnel/Equipment	Total Inf Bn	Bn Hq	Mortar Btry	Anti-tank Plt	Supply & Maint Plt	Three Inf Co (Total)
Officers	X	X	X	X	X	18
Enlisted Personnel	X	X	X	X	X	231
Total	365	X	X	X	X	249
9-mm Pistols	18+	X	X	X		18
7.62-mm Assault Rifles	231+	X	X	X	X	231
Machineguns	X					X
RPG-7 Antitank Grenade Launchers	X					X
82/120-mm Mortars	6		6			
57/76-mm Antitank Guns	2		2			
Armored Recon Vehicles	X					
Armored Personnel Carriers	X	X				

X - Specific data not available.

Appendix E

ORGANIZATION OF A REPRESENTATIVE MECHANIZED INFANTRY DIVISION

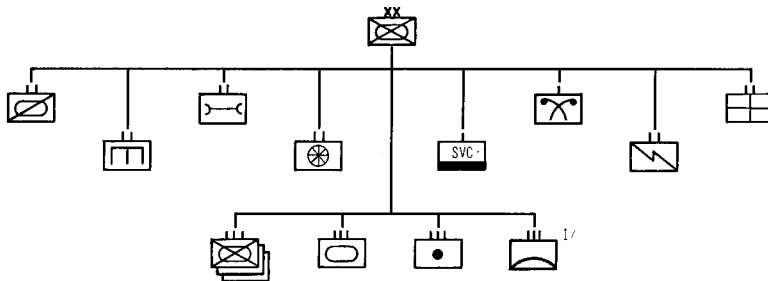

1/ ADA regiment probably a Category II or III unit. Maximum strength is 600 with four firing batteries and no battalions. Some batteries may have self-propelled AA guns.

TABLE OF PERSONNEL AND MAJOR EQUIPMENT

Personnel/Equipment	Total Mech Inf Div	Armd Recon Bn	Engr Bn	Maint Bn	Trnsp Bn	Chem Def Co	Supply & Svc Co	Sig Bn	Med Bn	Three Mech Inf Regt (Total)	Tank Regt	Arty Regt	ADA Regt
Total Personnel	8,200	X	300	150	X	45	X	250	140	4,320	720	975	600
Machineguns	X	X								X	X		
RPG-7 Antitank Grenade Launchers	X	X								X			
Mortars	36-54									36-54			
Self-Propelled/Towed ADA Guns	48+									36	12		X
Antitank Guided Missiles on BRDMs	X	X								X			
Medium Tanks/SU-100 Assault Guns	126+									63	63+		
PT-76 Light Tanks	12+	X								9	3		
Light (Antitank) Guns	30									12		18	
Medium/Heavy Guns/Howitzers	18-36									0-18		18	
Multiple Rocket Launchers	18											18	
Mine-Clearing Devices	X		X							X	X		
Bridging Equipment	X		X							X	X		
Motorcycles w/Sidecars	X	X								X	X	X	
Armored Recon Vehicles	X	X								X	X		
Armored Personnel Carriers	X	X	X							X	X	X	

X - Specific data not available.

Appendix F

ORGANIZATION OF A REPRESENTATIVE MECHANIZED INFANTRY REGIMENT

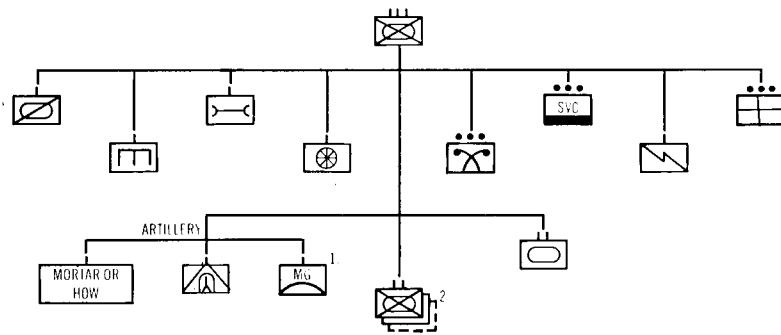

- 1/ Some AA batteries have SP AA guns
- 2/ If present, may exist as a Category III unit. Not counted in strength total

TABLE OF PERSONNEL AND MAJOR EQUIPMENT

Personnel/ Equipment	Total Mech Inf Regt	Armd Recon Co	Engr Co	Maint Co	Trnsp Co	Chem Def Plt	Supply & Svc Plt	Sig Co	Med Plt	Mort or How Btry	ATGM Btry	AA MG Btry	Two Mech Rifle Bn (Total)	Tank Bn
Total Personnel	1,440	X	50	X	X	X	X	X	X	X	X	70	860	110
Machineguns	X												114	
RPG 7 Antitank Grenade Launchers	X	X											54	
82/120-mm Mortars	12-18									0.6			12	
Self-Propelled/Towed ADA Guns	18											6		12
Antitank Guided Missiles on BRDMs	X													
57/76-mm Light (Antitank) Guns	4												4	
Medium/Heavy Guns/Howitzers	0-6									0.6				
Medium Tanks /SU-100 Assault Guns	21													21
Pt-76 Light Tanks	3	3												
Mine Clearing Devices	X													X
Motorcycles w/Sidecars	X	X												X
Armored Recon Vehicles	X	X									X			X
Armored Personnel Carriers	X									X				X

X - Specific data not available.

Appendix G

ORGANIZATION OF A REPRESENTATIVE MECHANIZED INFANTRY BATTALION

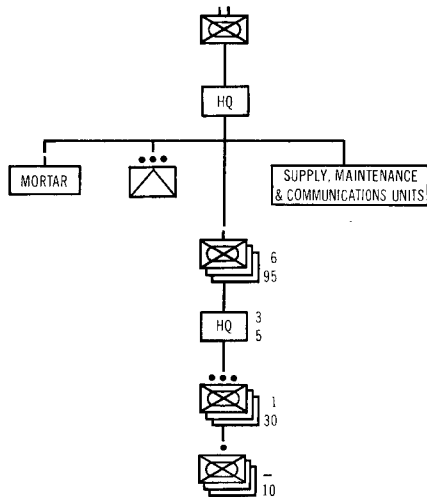

TABLE OF PERSONNEL AND MAJOR EQUIPMENT

Personnel/ Equipment	Total Mech Inf Bn	Bn Hq	Mort Btry	Anti-tank Plt	Supply, Maint & Comm Units	Three Mech Rifle Co (Total)
Officers	X		X	X	X	18
Enlisted	X		X	X	X	285
Total Personnel	430		X	X	X	303
9-mm Pistol	18+	X				18
7.62-mm Assault Rifles	285+		X	X	X	285
Machineguns	X					X
RPG-7 Antitank Grenade Launchers	27					27
82/120-mm Mortars	6		6			
57/76-mm Light (Antitank) Guns	2			2		
Armored Recon Vehicles	X	X				
Armored Personnel Carriers	30+	X				30

X - Specific data not available.

Appendix H

ORGANIZATION OF A REPRESENTATIVE ARMORED DIVISION

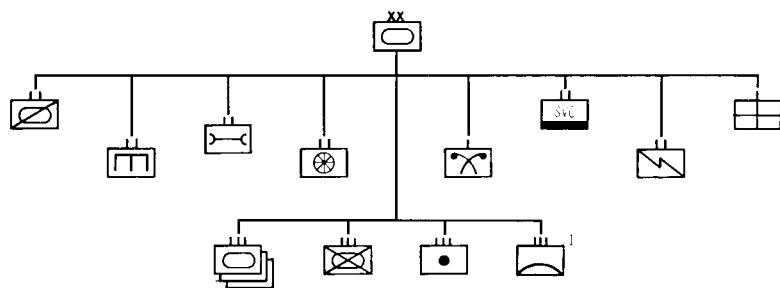

1/ ADA regiment probably a Category II or III unit.
 Maximum strength is 600 with four firing batteries and no battalions.
 Some batteries may have self propelled AA guns.

TABLE OF PERSONNEL AND MAJOR EQUIPMENT

Personnel/Equipment	Total Arm'd Div	Arm'd Recon Bn	Engr Bn	Maint Bn	Insp Bn	Chem Def Co	Supp & Svc Bn	Sig Bn	Med Co	Intra Tank Reg* (Total)	Mech Inf Reg*	Arty Reg*	ADA Reg*
Total Personnel	6,200	230	270	140	X	45	X	220	60	2,160	1,440	975	600
Medium Tanks/SU-100 Assault Guns	116+									195	21		
PT 76 Light Tanks	12+	X								9	3		
Self-Propelled/Towed ADA Guns	30+									18	6	6	X
RPG 7 Antitank Grenade Launchers	X	X									X		
Antitank Guided Missiles on BRDMs	X	X									X		
Mortars	12-18										12-18		
Light (Antitank) Guns	22										4	18	
Medium/Heavy Guns/Howitzers	18-24										0-6	18	
Multiple Rocket Launchers	18											18	
Bridging Equipment			X							X			
Mine Clearing Devices			X							X			
Motorcycles w/Sidecars	X	X								X	X	X	
Armored Recon Vehicles	X	X	X							X	X	X	
Armored Personnel Carriers	X	X	X							X	X	X	

X - Specific data not available.

Appendix I

ORGANIZATION OF A REPRESENTATIVE TANK REGIMENT

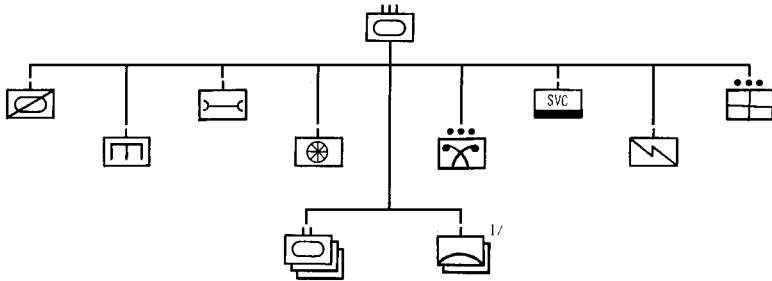

1/ In some units, the two ADA batteries may have only towed ADA guns; in others, one or both batteries may have SP ADA guns.

TABLE OF PERSONNEL AND MAJOR EQUIPMENT

Personnel/Equipment	Total Tank Regt	Armd Recon Co	Engr Co	Maint Co	Trnsp Co	Chem Def Plt	Supply & Svc Co	Sig Co	Med Plt	Three Tank Bn (Total)	Two ADA Btry (Total)
Total Personnel	720	X	50	X	X	X	X	X	X	330	X
Medium Tanks/SU-100 Assault Guns	63+									63	
RPG-7 Antitank Grenade Launchers	X	X									
PT-76 Light Tanks	3	3									
Self-Propelled/Towed ADA Guns	12										12
Bridging Equipment	X		X								
Mine-Clearing Devices	X		X							X	
Armored Recon Vehicles	X	X								X	
Armored Personnel Carriers	X									X	

X - Specific data not available.

Appendix J

ORGANIZATION OF A REPRESENTATIVE TANK BATTALION

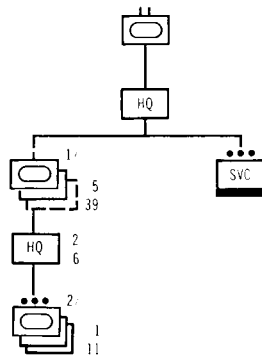

- 1/ The possible third tank company would be a Category III unit. Not counted in strength total.
- 2/ A tank platoon has three medium tanks. Some companies may have one platoon of SU-100 Assault Guns instead of medium tanks.

TABLE OF PERSONNEL AND MAJOR EQUIPMENT

Personnel/Equipment	Total Tank Bn	Bn Hq	Two Tank Co (Total)	Supply & Svc Plt
Officers	X	X	10	X
Enlisted Personnel	X	X	78	X
Total	110	X	88	X
Medium Tanks/SU-100 Assault Guns	21	1	20	
Mine-Clearing Devices	X		X	
Armored Recon Vehicles	X			
Armored Personnel Carriers	X			X

X - Specific data not available

Appendix K

PROBABLE ORGANIZATION OF THE ARTILLERY DIVISION^{1/}

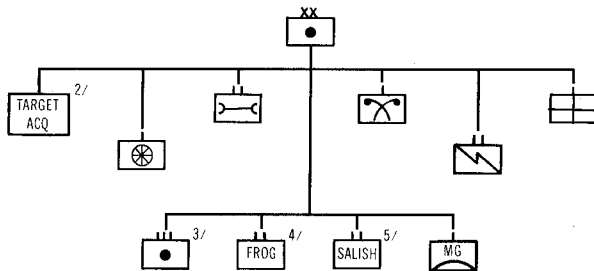

- 1/ Subordinate directly to MINFAR. Strength unknown. Functions like a US artillery group.
- 2/ Information on size, location and organization of the target acquisition unit is not available.
- 3/ Information on number of artillery regiments is not available.
- 4/ Information on number of FROG battalions is not available. Each battalion has four rocket launchers.
- 5/ Information on number and composition of SALISH battalions is not available.

TABLE OF PERSONNEL AND MAJOR EQUIPMENT

Personnel/Equipment	Total Arty Div	Tgt Acq Unit	Trnsp Co	Maint Bn	Chem Def Co	Sig Bn	Med Co	Arty Regt	FROG Bn	SALISH Bn	ADA Btry
Total Personnel	UNK	X	X	X	X	X	X	X	X	X	X
Light (Antitank) Guns	X							X			
Medium/Heavy Guns/Howitzers	X							X			
Multiple Rocket Launchers	X							X			
FROG-5s	X								X		
SSC-2a SALISH	X									X	
Air Defense Machineguns	6										6
Motorcycles w/Sidecars	X	X						X			
Armored Recon Vehicles	X										
Armored Personnel Carriers	X										

X - Specific data not available.

Appendix L

ORGANIZATION OF A REPRESENTATIVE ARTILLERY REGIMENT

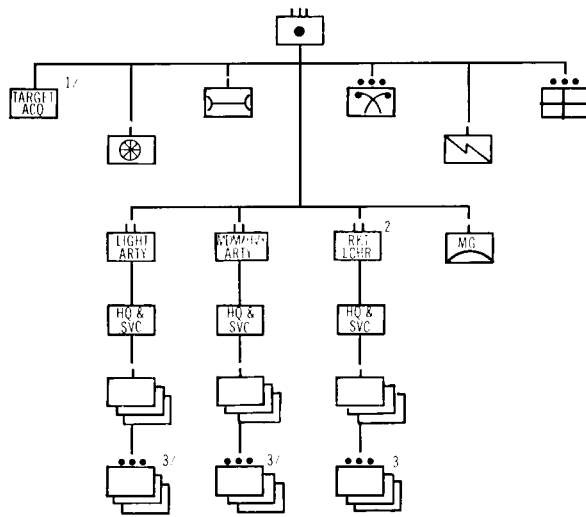

1/ Information on the size, location and organization of the target acquisition unit is not available

2/ This capability exists in Cuban divisions. The most logical controlling HQ is the artillery regiment.

3/ Each platoon has two weapons

TABLE OF PERSONNEL AND MAJOR EQUIPMENT

Personnel / Equipment	Total Artillery Regt	Tgt Acq Unit	Insp Co	Maint Co	Chem Def Plt	Sig Co	Med Plt	Light Art Bn	Med Hvy Art Bn	Multi Rkt Lchr Bn	ADA Btry
Total Personnel	975	X	X	X	X	X	X	200	300	210	X
Light (Antitank) Guns	18							18			
Medium/Heavy Guns/Howitzers	18								18		
Multiple Rocket Launchers	18									18	
Air Defense Machineguns	6										6
Motorcycles w/Sidecars	X	X									
Armored Recon Vehicles	X										
Armored Personnel Carriers	X										

X - Specific data not available.

APPENDIX M

Army Equipment

This appendix presents the technical characteristics of the principal Cuban Army equipment; the sketches are not to scale. The Cubans possess additional equipment and some of the older or less common items in the inventory are not listed. Unless otherwise stated, the equipment is of Soviet origin.

The following types of equipment are described:

	Page
Armored Vehicles	A-14
Tanks	A-14
Assault Gun	A-15
Armored Personnel Carriers	A-15
Amphibious Armored Infantry Combat Vehicle	A-16
Armored Reconnaissance Vehicles	A-16
Infantry Weapons	A-17
Small arms	A-17
Antitank	A-19
Man-portable Antiaircraft Missile	A-19
Field Artillery	A-20
Mortars	A-20
Field Guns and Howitzers	A-21
Antitank Guns	A-23
Multiple Rocket Launchers	A-23
Tactical Rocket and Missile	A-24
Air Defense Artillery	A-25
Towed Antiaircraft Guns	A-25
Self-propelled Antiaircraft Guns	A-27
Engineer Equipment	A-28
Vehicle Launched Bridges	A-28
Tracked Self-Propelled Ferry	A-28
Bridging	A-28
Tracked Tractors	A-29
Load-Carrying, Wheeled Vehicles	A-30
Trucks	A-30
Chemical Equipment	A-31
Flamethrower	A-31
Smoke munitions	A-31
Decontaminants and Equipment	A-31

ARMORED VEHICLES

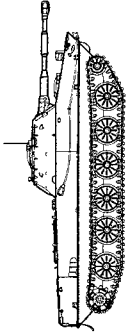
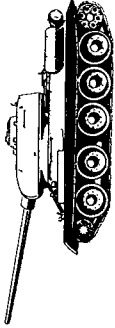
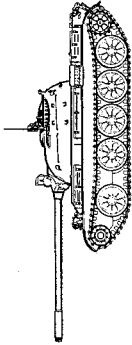
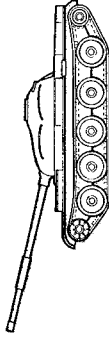
Equipment	Technical Characteristics	Role	Remarks
<p>Tanks</p> <p>PT-76</p> 	<p>Crew: 3 Combat weight: 14 tons Main armament: 76mm Basic load: 40 rounds Coaxial: 7.62mm SGMT MG Speed—land: 44 km/hr —water: 10 km/hr Cruising range: 260 km</p>	<p>Recon (light tank)</p>	<p>Two different models of tank gun; both ballistically identical and fire the same ammunition. Lightly armored but has excellent amphibious characteristics.</p>
<p>T-34(85)</p> 	<p>Crew: 4-5 Combat weight: 32 tons Main armament: 85mm Basic load: 56-60 rounds Bow: 7.62mm DTM MG Coaxial: 7.62mm DTM MG Speed: 55 km/hr Cruising range: 300 km</p>	<p>Main battle tank (medium)</p>	<p>Being replaced by T-54/55 and T-62.</p>
<p>T-54/55</p> 	<p>Crew: 4 Combat weight: 36 tons Main armament: 100mm Basic load: T-54, 34 rounds T-55, 43 rounds Antiaircraft: T-54, 12.7mm DShK MG Bow: 7.62mm SGMT or PKT MG Coaxial: 7.62mm SGMT or PKT MG Speed: T-54, 48 km/hr T-55, 50 km/hr Cruising range: T-54, 400 km T-55, 500 km</p>	<p>Main battle tank (medium)</p>	<p>T-55 has improved snorkeling arrangements and later models can operate in contaminated areas.</p>
<p>T-62</p> 	<p>Crew: 4 Combat weight: 36.5 tons Main armament: 115mm smooth bore Basic load: 40 rounds Coaxial: 7.62mm PKT MG Speed: 50 km/hr Cruising range: 500 km</p>	<p>Main battle tank (medium)</p>	<p>115mm ammunition is fin-stabilized. First seen in Cuba in late 1976.</p>

ARMORED VEHICLES

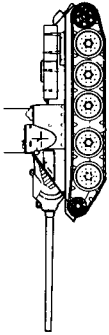
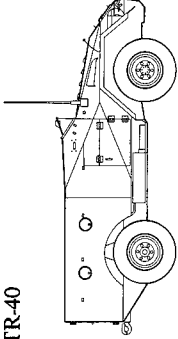
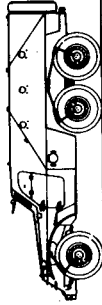
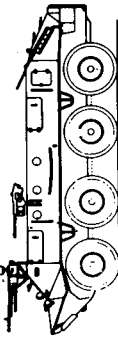
Equipment	Technical Characteristics	Role	Remarks
<p>SU-100</p> 	<p>Crew: 4 Combat weight: 31.6 tons Main armament: 100mm Basic load: 34 rounds Speed: 55 km/hr Cruising range: 300 km</p>	<p>Assault</p>	<p>Some SU-100s are organic to tank companies.</p>
<p>Armored Personnel Carriers</p> <p>BTR-40</p> 	<p>Crew: 2 Passengers: 8 Combat weight: 5.3 tons Armament: 7.62mm SGMB MG Wheels: 4 Speed: 80 km/hr Cruising range: road, 285 km</p>	<p>APC</p>	<p>Not amphibious. Principal use: command and reconnaissance vehicle. Being replaced by BRDM and BRDM-2 (armored reconnaissance vehicles).</p>
<p>BTR-152</p> 	<p>Crew: 2 Passengers: 17 Combat weight: 8.95 tons Armament: 7.62mm SGMB MG Wheels: 6 Speed: 75 km/hr Cruising range: road, 650 km</p>	<p>APC</p>	<p>Not amphibious.</p>
<p>BTR-60P BTR-60PA</p> 	<p>Crew: 2 Passengers: 16 Combat weight: 9.98 tons Armament: 7.62mm SGMB MG Wheels: 8 Speed: land, 80 km/hr water, 10 km/hr Cruising range: road, 500 km</p>	<p>APC</p>	<p>BTR-60P (shown) has no overhead armored cover. Some have two additional MGs (shown). BTR-60PA has overhead armored cover.</p>

ARMORED VEHICLES

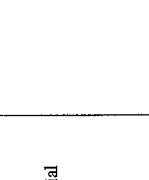
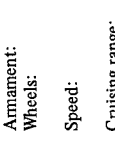
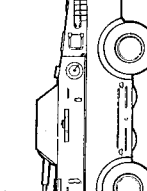
Equipment	Technical Characteristics	Role	Remarks
<p>Armored Personnel Carriers (cont)</p> <p>BTR-60PB</p> 	<p>Crew: 2 Passengers: 14 Combat weight: 10.3 tons Armament: Main: 14.5mm KPVT MG Secondary: 7.62mm PKT MG Wheels: 8 Speed: land, 80 km/hr water, 10 km/hr Cruising range: road, 500 km</p>	<p>APC</p>	
<p>Amphibious Armored Infantry Combat Vehicle</p> <p>BMP</p> 	<p>Crew: 3 Passengers: 8 Combat weight: 12.5 tons Armament: AT-3 SAGGER Missile 73mm smoothbore gun PKT 7.62mm MG coaxial Tracked Speed: land, 60 km/hr water, 8 km/hr Cruising range: 500 km</p>	<p>APC</p>	<p>Maximum range of SAGGER, about 3,000 meters. Minimum range of SAGGER, about 500 meters. 73mm smoothbore gun fires fir-stabilized HEAT projectiles; effective range, about 800 m. Probably used by Cubans in Ethiopia in 1977/78. First displayed in Cuba in January 1979.</p>
<p>Armored Reconnaissance Vehicles</p> <p>BRDM</p> 	<p>Crew: 5 Combat weight: 5.6 tons Armament: 7.62mm SGMB MG Wheels: 4 (plus 4 rough terrain wheels) Speed: land, 80 km/hr water, 9 km/hr Cruising range: road, 500 km</p>	<p>Command/reconnaissance</p>	<p>Also called BTR-40P. Some may be equipped with antitank guided missiles (not shown).</p>
<p>BRDM-2</p> 	<p>Crew: 4 Combat weight: 7 tons Armament: Main: 14.5mm KPVT MG Secondary: 7.62mm PKT MG Wheels: 4 (plus 4 rough terrain wheels) Speed: land, 100 km/hr water, 10 km/hr Cruising range: road, 750 km</p>	<p>Command/reconnaissance</p>	<p>Also called BTR-40P-2. BRDM-2 armament same as that used in BTR-60PB. As a command vehicle, BRDM-2 has no armament. It has a rectangular box on top.</p>

ARMORED VEHICLES

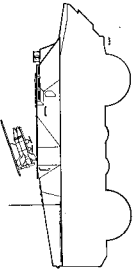
Equipment	Technical Characteristics	Role	Remarks
Armored Reconnaissance Vehicle (cont) 	Characteristics probably the same as BRDM-2 (without armament).	Antitank/reconnaissance	Maximum range of SAGGER, about 3,000 meters. Minimum range of SAGGER, about 500 meters. First seen in Cuba in late 1975.



INFANTRY WEAPONS

Weapons	Technical Characteristics							Remarks
	Caliber	Type of Fire	Weight (kg)	Feed	Effective Range (meters)	Practical Rate of Fire (rpm)	Ammunition	
Small Arms								
Pistol, Makarov (PM)	9mm	semiauto	loaded: 0.81	8-round magazine	50	30	9x18mm	---
Pistol, Stechkin (APS)	9mm	semiauto; auto	loaded: 1.22	8-round magazine	50	semiauto: 40 auto: 90	9x18mm	With holster-stock, it can be used as a small submachinegun.
Assault Rifle, Kalashnikov (AK-47)	7.62mm	semiauto	loaded: about 4.3	30-round box magazine	400	40-100	7.62x39mm	Several versions including one with folding stock and bayonet. Being replaced by AKM.
Modernized Assault Rifle, Kalashnikov (AKM)	7.62mm	semiauto	loaded: about 3.86	30-round box magazine	400	40-100	7.62x39mm	Sometimes with bayonet. With folding stock, called AKMS. AKM replacing AK-47.
Assault Rifle, F.A.L.	7.62mm	semiauto; auto	loaded: 5.06	20-round box magazine	600	semiauto: 60 auto: 120	7.62x51mm (NATO)	Belgian.
Sniper Rifle, Dragunov (SVD)	7.62mm	semiauto	loaded: 4.52	10-round magazine	800	30	7.62x54mm	---
Submachinegun, Shpagin, M1941 (PPSh)	7.62mm	semiauto; auto	with loaded drum magazine: 5.3	71-round drum magazine or 35-round box magazine	short burst: 200 long burst: 100	semiauto: 30 auto: 100	7.62x25mm	---

INFANTRY WEAPONS

Weapons	Technical Characteristics							Remarks
	Caliber	Type of Fire	Weight (kg)	Feed	Effective Range (meters)	Practical Rate of Fire (rpm)	Ammunition	
Small Arms (cont)								
Submachinegun, M23	9mm	semiauto; auto	with loaded 24-round magazine: 3.7	24-round or 40-round box magazine	150	semiauto: 50 auto: 80-100	9mm Para- bellum	Czech.
Semiautomatic Rifle, M52	7.62mm	semiauto	loaded: 4.45	10-round maga- zine	400	25	7.62x45mm	Czech.
Light Machinegun, F.A.Lo.	7.62mm	semiauto; auto	loaded with bipod: 6.2	20-round box magazine	1,200		7.62x51mm	Belgian.
Light Machinegun, Modernized Degtyarev (DPM)	7.62mm	auto	with loaded drum: 11.9	47-round flat drum magazine	800	80	7.62x54mm	---
Company Machinegun, M1946 (RP-46)	7.62mm	auto	with loaded drum: 15.8	47-round flat drum magazine or 250-round belt	1,000	230-250	7.62x54mm	Can use DPM drum magazine. Being replaced by PK/PKS.
Light Machinegun, Degtyarev (RPD)	7.62mm	auto	with loaded drum: 9.0	100-round drum	800	150	7.62x39mm	Being replaced by RPK.
Light Machinegun, Kalashnikov (RPK)	7.62mm	semiauto; auto	with loaded drum: 7.1	75-round drum or 40-round box magazine	800	semiauto: 50 auto: 150	7.62x39mm	RPK is basically AKM Assault Rifle. RPK can also use AK-47/AKM magazines. Replacing RPD.
Machinegun, Kalashnikov (PK/PKS/PKT/PKB)	7.62mm	auto	PK, with bipod un- loaded: 9.0 PKS, with tripod un- loaded: 16.5	3 belts: 100, 200 and 250 rounds	1,000	250	7.62x54mm	PK, bipod-mounted with 100- round boxed belt. PKS, PK with tripod. Other versions: PKT for armored vehicles; PKB for APCs. Replacing SGM series.
Machinegun, Modernized Goryunov M1943 (SGM/SGMT/SGMB)	7.62mm	auto	gun only: 13.5	250-round belt (five 50-round metallic belts)	1,000	250-300	7.62x54mm	SGMT, SGM mounted on tanks. SGMB, SGM mounted on APCs. SGM series being replaced by PK series.
Heavy Machinegun, Degtyarev-Shpagin M1938/46 (DShKM)	12.7mm	auto	gun only: 34.0 gun and tripod: 131.5	50-round box	horizontal: 1,500 antiaircraft: 1,000	80	12.7x108mm	DShKM mounted on T54/55 called DShKT. Also used as antiaircraft weapon. Basic weapon for Quad 12.7mm Heavy Machinegun M-53 (towed aircraft gun).

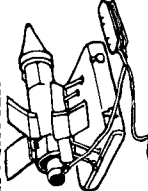
INFANTRY WEAPONS

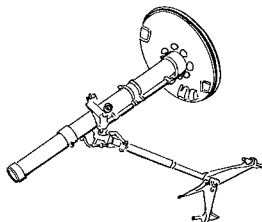
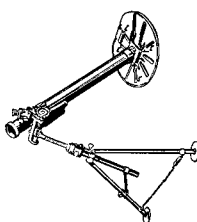
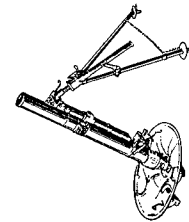

Weapons	Technical Characteristics							Remarks
	Caliber	Type of Fire	Weight (kg)	Feed	Effective Range (meters)	Practical Rate of Fire (rpm)	Ammunition	
Small Arms (cont)								
Heavy Machinegun, Vladimirov (KPV/KPVT)	14.5mm	auto	gun only: 51.0	metallic link belt	horizontal 2,000 antiaircraft 1,400	150	14.5x114mm	KPV on BTR-60PB (APC) and BRDM-2 (armored recon vehicle) called KPVT. Also used as antiaircraft weapon. Basic weapon for ZPU-2 and ZPU-4 (towed antiaircraft gun).
Antitank (AT)								
Antitank Grenade Launcher (RPG-7/RPG-7V)	Tube: 40mm Launcher: RPG-7, 80mm RPG-7V, 85mm		Loaded RPG-7, 8.2 RPG-7V, 9.0		Standing targets, 500 Moving targets, 300	4-6	HEAT and HE	RPG-7V is improved RPG-7.
AT-1 SNAPPER			N/A		Out to 2,000			Wire-guided.
AT-3 SAGER 			11		500-3,000			Wire-guided. Map-pack: 3-man crew. Also mounted on BRDM-2 and BRDM.
Man-Portable Antiaircraft Missile								
SA-7 (GRAIL) 			N/A		Slant range: 3,000-5,000			Shoulder-fired weapon. Used against low-flying fixed and rotary wing aircraft. Used by Cubans and Soviet/Cuban-supported forces in Angola.

FIELD ARTILLERY

Mortars	Technical Characteristics						Remarks
	Caliber	Firing Position Weight (kg)	Ammunition (type; weight) (kg)	Effective HE Range (max-min) (meters)	Practical Rate of Fire (rpm)	Crew	
Mortar M1941 	82mm	52	HE:3.05	3,040-100	15-25	5	Man-portable. Not stable in firing position.
Mortar M1937 	82mm	56	HE:3.05	3,040-100	15-25	5	Man-portable.
Mortar M1938 Mortar M1943 	120mm	274.8	HE:15.4	5,700-460	12-15	6	Drawing and data for M1943. M1938 ballistically identical with M1943. M1943 has longer shock absorber cylinders. Can be drop- or trigger-fired.

FIELD ARTILLERY

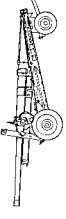

Mortars	Technical Characteristics						Remarks
	Caliber	Firing Position Weight (kg)	Ammunition (type; weight) (kg)	Effective HE Range (max-min) (meters)	Practical Rate of Fire (rpm)	Crew	
Mortar M1943 	160mm	1,170	HE-40.8	5,150-630	3	7	Breechloaded.
Mortar M-160	160mm	1,300	HE-41.5	8,040-750	2-3	7	Breechloaded. Very similar in design to 160mm M1943 but has a longer tube.

Field Guns and Howitzers	Technical Characteristics						Remarks	
	Crew	Rate of Fire (rpm)	Maximum Range (meters)	Ammunition	Projectile Weight (kg)	Point Blank Range at 2-m-high Target (meters)		Armor Penetration at 0° (mm)
100mm Field Gun M1955 	6	7	15,400	HE APHE HEAT	15.7 15.9 12.2	Not available 1,080 1,000	Not available Not available 380 (at any range)	Fires same ammunition as 100mm tank guns.
122mm Howitzer M1938 (M-30) 	7	5-6	11,800	HE HEAT	21.8 13.3	Not available 630	Not available 200 (at any range)	---
122mm Corps Gun M1931/37 (A-19) 	8	5-6	20,800	HE APHE	25.5 25.0	Not available 160	Not available 160 (at 1,000m)	---

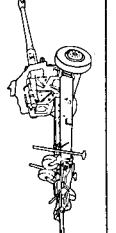
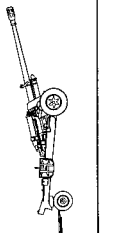
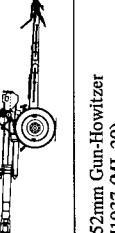
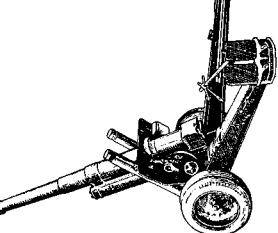
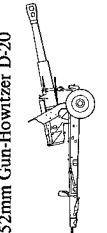
FIELD ARTILLERY



Field Guns and Howitzers	Technical Characteristics							Remarks
	Crew	Rate of Fire (rpm)	Maximum Range (meters)	Ammunition	Projectile Weight (kg)	Point Blank Range at 2-m-high Target (meters)	Armor Penetration at 0° (mm)	
122mm Field Gun D-74 	10	6-7	24,000	HE APHE	27.3 25.0	Not available 1,070	Not available 185 (at 1,000m)	--
130mm Field Gun M-46 	9	5-6	27,000	HE APHE	33.4 33.6	Not available 1,170	Not available 230 (at 1,000m)	--
152mm Howitzer M1943 (D-1) 	7	3-4	12,400	HE semi-AP	39.9 51.1	Not available 510	Not available 82 (at 500m)	Semi-AP: naval projectile has a larger HE burst than in normal APHE.
152mm Gun-Howitzer M1937 (ML-20) 	9	3-4	17,265	HE APHE	43.6 48.8	Not available 800	Not available 124 (at 1,000m)	Ammunition is similar to but not interchangeable with 152mm Gun-Howitzer D-20.
152mm Gun-Howitzer D-20 	10	5	18,500	HE APHE	43.6 48.8	Not available 850	Not available 130 (at 1,000m)	Ammunition is similar to but not interchangeable with 152mm Gun-Howitzer (ML-20).

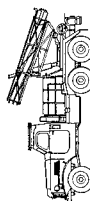
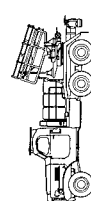

FIELD ARTILLERY

Field Guns and Howitzers	Technical Characteristics						Remarks	
	Crew	Rate of Fire (rpm)	Maximum Range (meters)	Ammunition	Projectile Weight (kg)	Point Blank Range at 2-m-high Target (meters)		Armor Penetration at 0° (mm)
Antitank Guns 57mm Antitank Gun M1943 (ZIS-2) 	7	25	8,400	HE APHE HVAP	2.8 3.1 1.8	Not available 1,150 1,250	Not available 106 140 (at 500m)	---
76mm Division Gun M1942 (ZIS-3) 	7	15-20	13,290	HE APHE HVAP HEAT	6.2 6.5 3.1 4.0	Not available 820 1,000 500	Not available 69 92 120 (at 500m)	---
85mm Division Gun D-44 	8	15-20	15,650	HE APHE HVAP	9.5 9.3 5.0	Not available 950 1,150	Not available 102 130 (at 1,000m)	---

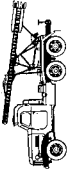
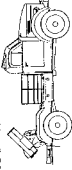
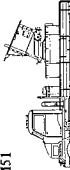
Multiple Rocket Launchers	Technical Characteristics				Remarks	
	Number of Tubes	Maximum Range (meters)	Weight per Rocket (kg)	Time to Reload (minutes)		Crew
200mm Rocket Launcher BMD-20 	4	20,000	91.4	6-10	6	Probably being phased out.
240mm Rocket Launcher BM-24 	12	10,200 6,575	109 112	3-4	6	Top line of range and weight is for rocket with a longer rocket motor and a smaller warhead.

FIELD ARTILLERY

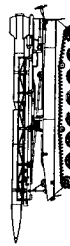
Multiple Rocket Launchers	Technical Characteristics				Remarks
	Number of Tubes	Maximum Range (meters)	Weight per Rocket (kg)	Time to Reload (minutes)	
130mm Rocket Launcher BM-13 	16	9,000	42.5	5-10	6 Probably being phased out.
140mm Rocket Launcher BM-14-17 	17	9,810	39.6	1.5-2	6 ---
130mm Rocket Launcher M51 	32	8,200	24.2	2	6 Czech. Sometimes called RM-130. Mounted on Czech PRAGA V3S Truck.
122mm Rocket Launcher BM-21 	40	20,500 11,000	77.5 45.8	10	6 Top line of range and weight is for longer rocket. A third type of rocket is a short rocket with two rocket motors; it has a range almost as great as the long rocket. In Cuba and used in Angola by late 1975.

Tactical Rocket and Missile	Technical Characteristics			Remarks
	Range (km)	Type of Warhead	Crew	
Surface-to-Surface Free Rocket Over Ground (FROG-5) 	35	HE Chemical Atomic	Not available	Cuba is not known to have either chemical or atomic warheads.
Surface-to-Surface Guided Missile SSC-2A SALISH 	Not available	Not available	Not available	---

AIR DEFENSE ARTILLERY

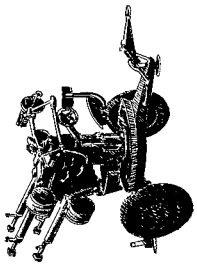
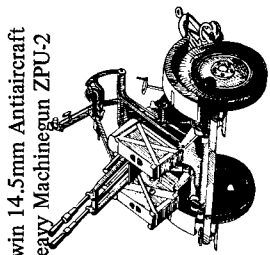
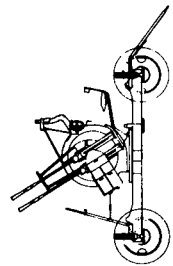
Towed Antiaircraft Guns	Technical Characteristics						Remarks
	Cyclic Rate of Fire per Barrel (rpm)	Practical Rate of Fire per Barrel (rpm)	Fire Control	Maximum AA Range Horizontal Vertical (meters)	Effective AA Range (meters)	Crew	
Quad 12.7mm Heavy Machinegun M-53 	540-600	80	Optic	6,500 5,600	1,000	6	Czech. Quad mount of 12.7mm Heavy Machinegun M1938/46 (DSHKM).
Twin 14.5mm Antiaircraft Heavy Machinegun ZPU-2 	600	150	Optic	8,000 5,000	1,400	2	Twin mount of 14.5mm Heavy Machinegun Vladimirov (KPV).
Quad 14.5mm Antiaircraft Heavy Machinegun ZPU-4 	600	150	Optic	8,000 5,000	1,400	5	Quad mount of 14.5mm Heavy Machinegun Vladimirov (KPV). Used in Angola.

AIR DEFENSE ARTILLERY

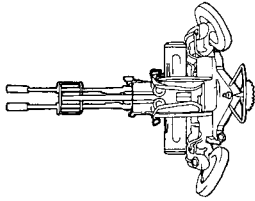
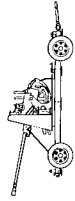
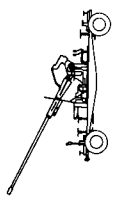
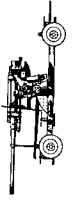
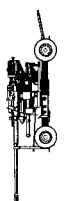
Towed Antiaircraft Guns	Technical Characteristics					Remarks	
	Cyclic Rate of Fire per Barrel (rpm)	Practical Rate of Fire per Barrel (rpm)	Fire Control	Maximum AA Range Horizontal Vertical (meters)	Effective AA Range (meters)		Crew
23mm Automatic Antiaircraft Gun ZU-23 	800-1,000	200	-	7,000 5,100	2,500	5	Same basic 23mm gun is used on self-propelled ZSU-23-4 (below). First seen in Cuba in early 1977.
37mm Automatic AA Gun M1939 	160-180	80	Optic	9,500 6,700	3,000	8	---
57mm Automatic AA Gun S-60 	105-120	70	Optic/ Radar	12,000 8,800	Off-carriage control: 6,000 On-carriage control: 4,000	7	Can be used in antiarmor role.
85mm AA Gun M1939 (KS-12) and M1944 (KS-12a) 	rate of fire: 15-20 rpm		Radar	15,650 10,500	8,382	7	Data and picture are for KS-12. KS-12A has improved ballistic performance. Can be used in antiarmor role. Ammunition interchangeable with 85mm field and tank guns.
100mm AA Gun (KS-19) 	rate of fire: 15 rpm		Radar	21,000 15,400	13,700	Not available	Can be used in antiarmor role.

AIR DEFENSE ARTILLERY

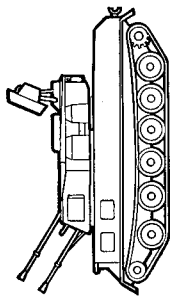
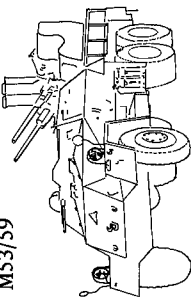
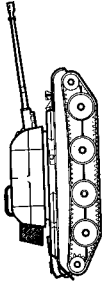
Self-propelled Antiaircraft Guns	Technical Characteristics							Remarks
	Combat Weight (ton)	Speed (km/hr)	Cruising Range (km)	Main Armament	Basic Load (rounds)	Traverse	Crew	
Twin 14.5mm Self-propelled Antiaircraft Machinegun on BTR-152A	9.6	65	650	Twin 14.5mm KPV	Not available	360°	4	Vehicle is modified open top wheeled BTR-152 (armored personnel carrier).
ZSU-23-4 	14	44	260	Quad 23mm	Not available	360°	4	On-carriage radar control. Radar has target acquisition and fire control capabilities. Same 23mm gun is used in ZU-23, towed antiaircraft gun (above).
Twin 30mm Self-propelled Antiaircraft Machinegun M53/59 	9.5	60	500	Twin 30mm M53/59	Not available	360°	3	Czech. Vehicle is armored version of PRAGA V3S (6x6) truck. Guns can be removed and fired from the ground. Some twin 30mm guns are also inserted on BTR-60 (armored personnel carrier).
ZSU-57-2 	28.1	48	400	Twin 57mm S-68	316	360°	6	Chassis is greatly modified T-54. S-68 gun has same performance charac- teristics as the single-towed 57mm S-60 when using on-carriage fire control. ZSU-57-2 has no provision for off- carriage fire control.

ENGINEER EQUIPMENT

Appendix M (cont)

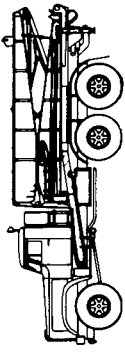
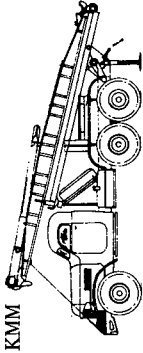
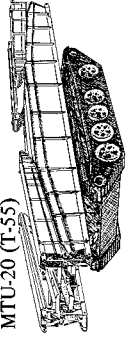
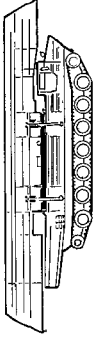
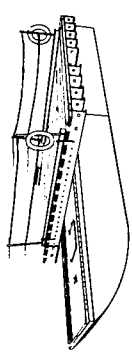
Equipment	Technical Characteristics	Role	Remarks
<p>Vehicle Launched Bridges</p> <p>TMM</p> 	<p>Load class: 60 Span unit: 10.5m Span set (4 units): 41.6m Launch time: day: 45-60 minutes night: 60-80 minutes Retrieval time: same as launch time</p>	<p>Truck-mounted scissors bridge</p>	<p>Launch time can be halved by well-trained crews. Can be laid under water. First seen in Cuba in late 1976.</p>
<p>KMM</p> 	<p>Load class: 15 Span unit: 7.0m Span set (5 units): 35m Launch time: day: 45-60 minutes night: 60-80 minutes Retrieval time: same as launch time</p>	<p>Truck-mounted scissors bridge</p>	<p>Launch time can be halved by well-trained crews. Can be laid under water.</p>
<p>MTU-20 (T-55)</p> 	<p>Load class: 60 Span: 20m (18m clear) Launch time: not available Retrieval time: not available Crew: 2</p>	<p>Cantilever tank bridge</p>	<p>First seen in Cuba in late 1976.</p>
<p>Tracked Self-propelled Ferry</p> <p>GSP</p> 	<p>Load class: not available Speed: water, without load: 10.8 km/hr water, with load: 7.7 km/hr</p>	<p>Heavy amphibious ferry</p>	<p>Capable of carrying medium and heavy tanks. Under favorable circumstances, a tank can fire its main armament when it is on the ferry. Two GSPs (one for left side, another for right) needed to form ferry. Sides are similar but not interchangeable. First seen in Cuba in late 1976.</p>
<p>Bridging</p> <p>TMP</p> 	<p>Load class: 70 Length of bridge: 109m Assembly time: 3 hours</p>	<p>Heavy pontoon bridge</p>	<p>---</p>

TRACKED VEHICLES

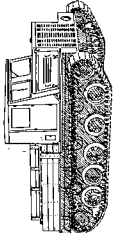
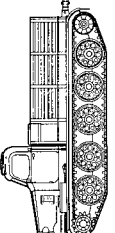
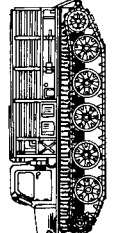
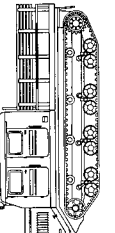
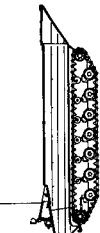
Vehicle	Technical Characteristics							Remarks
	Weight (kg)	Speed (km/hr)	Cruising Range (km)	Crew	Passengers	Payload (kg)	Towed Load (kg)	
Light Tracked Artillery Tractor Ya-12 or Ya-13F 	Ya-12: 6,500 Ya-13F: 5,700	Ya-12: 37 Ya-13F: 23	Ya-12: 290 Ya-13F: 210	2	Not available	2,000	Ya-12: 8,000 Ya-13F: 5,000	Ya-12 and Ya-13F are identical in appearance. Ya-12 is diesel-powered; Ya-13F is gasoline-powered.
Light Tracked Artillery Tractor AT-L and AT-LM 	6,300	42	300	3	8	2,000	6,000	AT-LM identical to AT-L except that AT-LM has only five large road wheels and no track support.
Medium Tracked Artillery Tractor ATS-59 	13,000	39	350	2	14	3,000	14,000	---
Medium Tracked Artillery Tractor AT-S 	12,000	35	380	7	10	3,000	16,000	---
Tracked Amphibian K-61 (GPT) 	9,550	land: 36 water: 10	260	2	60	land: 3,000 water: 5,000	Not available	Not armored.

LOAD-CARRYING, WHEELED VEHICLES

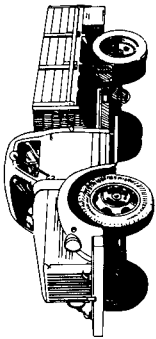
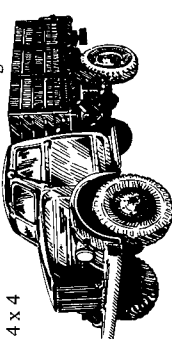
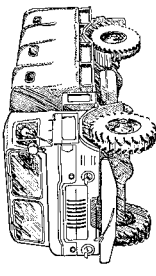
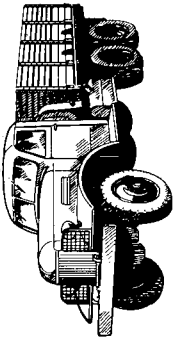
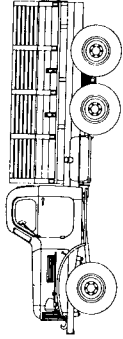
Trucks	Technical Characteristics				Remarks
	Weight (kilograms)	Maximum Payload (kilograms)	Towed Load (kilograms)	Cruising Range (kilometers)	
GAZ 51 2-1/2-ton Cargo Truck, 4 x 2 	2,500	2,500	2,500	450	Cargo and prime mover use.
GAZ 63 and GAZ-63A 2-ton Cargo Truck, 4 x 4 	3,200	2,000	2,000	780	Drawing and data for GAZ-63; GAZ-63A improved version of GAZ-63. Used to tow mortars and to carry multiple rocket launchers such as BM-14-17. GAZ-63 series being replaced by GAZ-66 series.
GAZ-66A Truck, 4 x 4 	3,700	2,000	2,000	525	Replacing GAZ-63 series. Several versions with specialized bodies.
ZIL-151, 5-ton Cargo Truck, 6 x 6 	5,580	4,500	3,600	600	Used as cargo truck, prime mover for artillery pieces and for several multiple rocket launchers. Also has specialized bodies. Being replaced by ZIL-157.
ZIL-157 2-1/2-ton Cargo Truck, 6 x 6 	5,800	4,500	3,600	430	Replacing ZIL-151 in all its roles.

LOAD-CARRYING, WHEELED VEHICLES

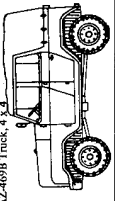
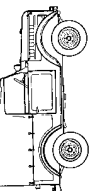
Trucks	Technical Characteristics			Remarks	
	Weight (kilograms)	Maximum Payload (kilograms)	Towed Load (kilograms)		
UAZ-469B Truck, 4 x 4 	1,540	two persons and 600-kg cargo or seven persons and 100-kg cargo	850	750	---
UAZ (GAZ) 69 Truck, 4 x 4 	1,525	900	800	530	Several versions of UAZ (GAZ) 69 Trucks. Used for light cargo and personnel carrier, sometimes as prime mover for mortar and also as a communications vehicle. UAZ 69A is a 5-man passenger vehicle only.

CHEMICAL EQUIPMENT

Equipment	Technical Characteristics	Remarks
Flamethrower		---
LPG-50 Portable Flamethrower	Not available.	
Smoke Munitions		
Smoke Handgrenade RDG-1	Filled with either a white or a black smoke mixture.	Can float on water.
Smoke Handgrenade RDS-2	Weight: about 500 grams. Burns for about 1.5-2 minutes.	---
Decontaminants and Equipment		
IDP Individual Armament Degasifier	Decontamination kit for individual weapons (rifles, light machineguns, pistols, etc.). Decontaminates zarin, mustard gas, and Vx gases. Contains two vials of liquid.	---
ARS-12	Decontamination apparatus, truck-mounted, for weapons, vehicles, other equipment and terrain.	Two versions: ARS-12D (on ZIL-151 chassis); ARS-12L (on ZIL-157 chassis). Has fuel-type tank on body.
DDA-53	Decontamination apparatus. Steam decontaminates clothing and small items and provides hot water for showers and personnel decontamination.	Mounted on either GAZ-51, GAZ-63 or GAZ-69 chassis. Has one boiler in front and two chambers.

APPENDIX N: ILLUSTRATIONS OF CUBAN NAVAL CRAFT

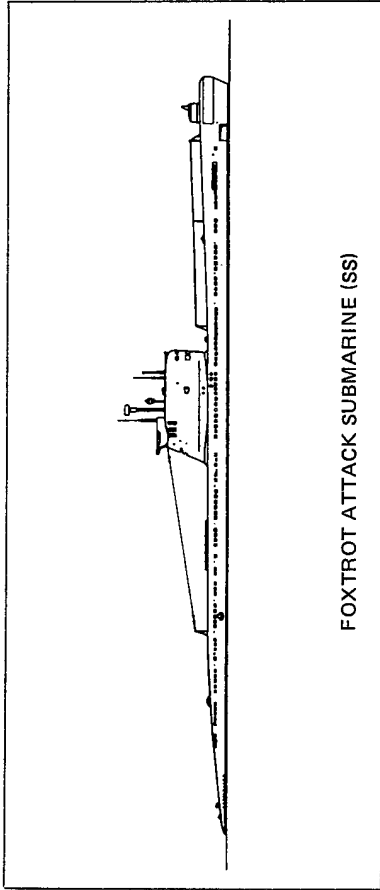

FOXTROT ATTACK SUBMARINE (SS)

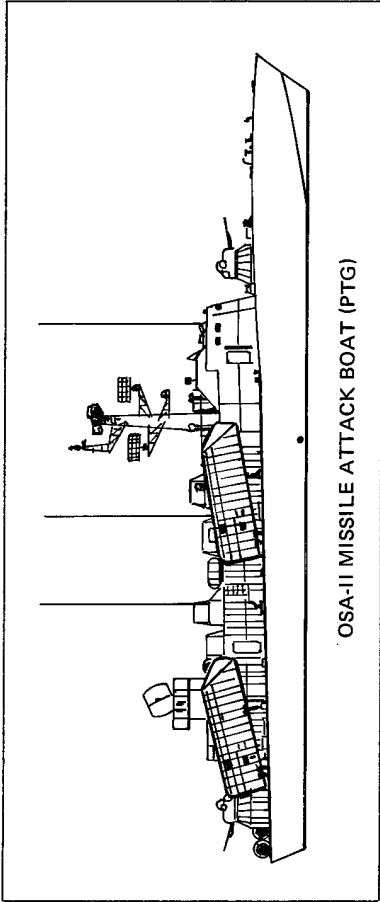

OSA-II MISSILE ATTACK BOAT (PTG)

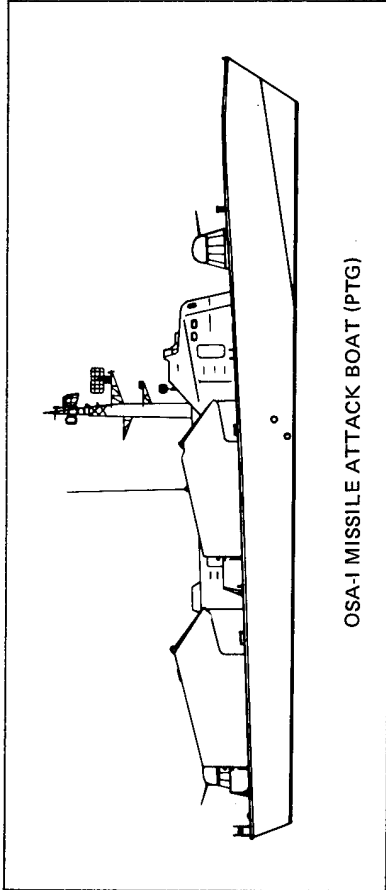

OSA-I MISSILE ATTACK BOAT (PTG)

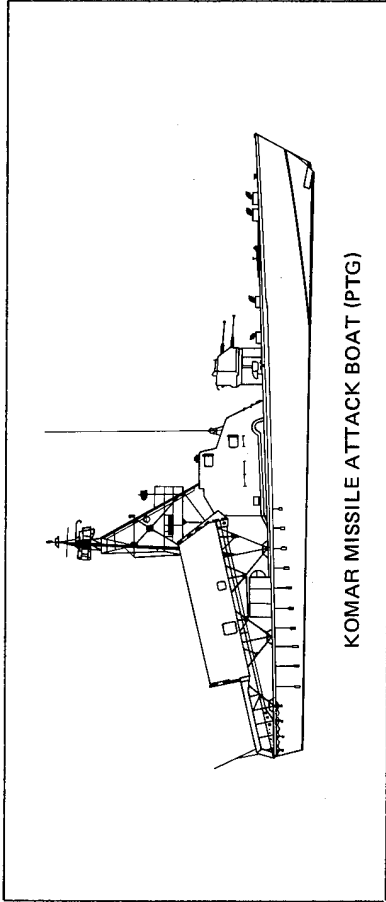

KOMAR MISSILE ATTACK BOAT (PTG)

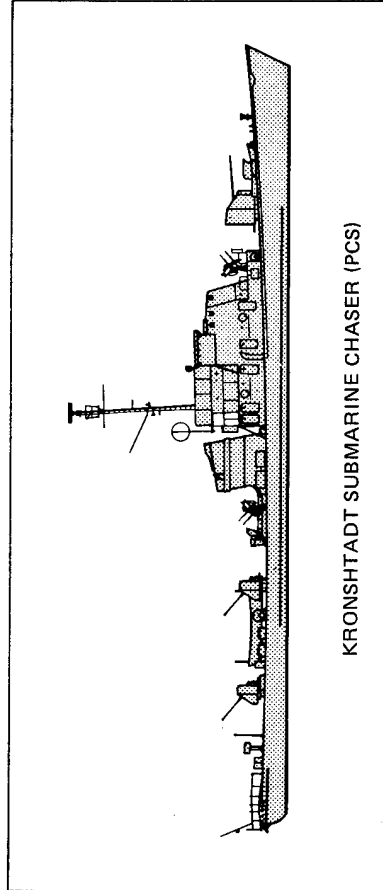

KRONSHITADT SUBMARINE CHASER (PCS)

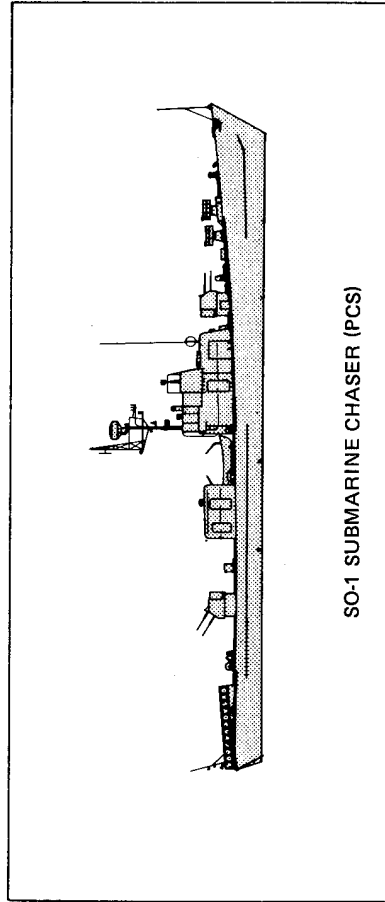

SO-1 SUBMARINE CHASER (PCS)

APPENDIX N: ILLUSTRATIONS OF CUBAN NAVAL CRAFT (cont)

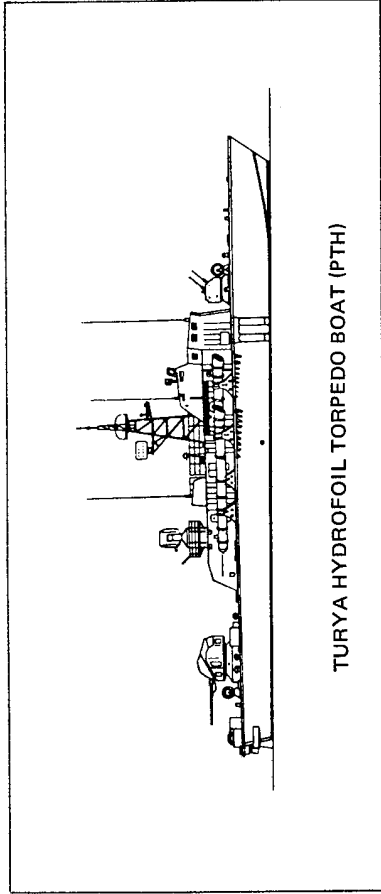

TURYA HYDROFOIL TORPEDO BOAT (PTH)

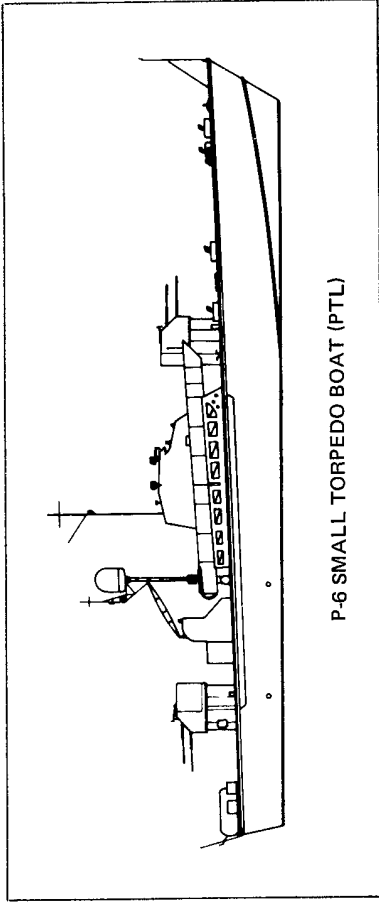

P-6 SMALL TORPEDO BOAT (PTL)

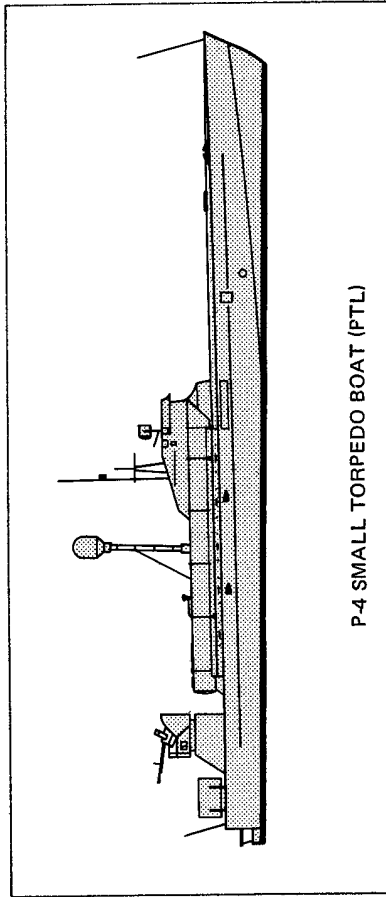

P-4 SMALL TORPEDO BOAT (PTL)

Appendix O

SELECTED CHARACTERISTICS OF PRINCIPAL NAVAL CRAFT

TYPE (US Navy Designator)	CLASS	Displace- ment-tons	Length (m)	Beam (m)	Draft (m)	Armament	Max speed (Knots)	Range	Engines BHP	Comple- ment
Attack Submarine (SS)	FOXTROT	2,100 surfaced 2,400 submerged	91	8	5	Six 533-mm torpedo tubes forward Four 400-mm torpedo tubes aft (total: 22 torpedoes or 44 mines)	18 surfaced 17 submerged	20,000 km surfaced, cruising	3 Diesels 6,000	70
Missile Attack Boat (PTG)	OSA-II	160 standard 200 full	39.3	7.7	1.8	Four SS-N-2 STYX Missiles Four 30-mm Guns (two twin mounts, one forward, one aft)	32	1,280 km at 25 knots	3 Diesels 13,000	25 - 30
Missile Attack Boat (PTG)	OSA-I	160 standard 200 full	39.3	7.7	2.0	Four SS-N-2 STYX Missiles Four 30-mm Guns (two twin mounts, one forward, one aft)	35	1,280 km at 25 knots	3 Diesels 13,000	25 - 30
Missile Attack Boat (PTG)	KOMAR	70 standard 80 full	25.5	6.0	1.8	Two SS-N-2 STYX Missiles Two 25-mm Guns (one twin mount forward)	40	640 km at 30 knots	4 Diesels 4,800	20
Submarine Chaser (PCS)	KRONSHADT	310 standard 380 full	52.0	6.5	2.7	One Depth-Charge Thrower One 88.9-mm Gun forward Two 37-mm Guns Aft (single mount) Four 25-mm Guns Aft (two twin mounts)	24	2,400 km at 12 knots	3 Diesels 3,030	65
Submarine Chaser (PCS)	SO-1	215 standard 250 full	42.3	6.1	2.8	Four 5-Barreled rocket launchers (ASW) Four 25-mm Guns (two twin mounts, one forward, one aft)	29	1,740 km at 13 knots	3 Diesels 6,000	30
Hydrofoil Torpedo Boat (PTH)	TURYA	200 standard 230 full	39.3	7.7	1.8	Four 533-mm torpedo tubes Two 25-mm Guns (twin mount, forward) Two 37-mm Guns (twin mount, aft)	40	Information not available	3 Diesels 14,000	30
Small Torpedo Boat (PTL)	P-6	66 standard 75 full	25.5	6.0	1.8	Two 533-mm torpedo tubes Four 25-mm Guns (two twin mounts, one forward, one aft)	40	720 km at 30 knots	3 Diesels 4,800	25
Small Torpedo Boat (PTL)	P-4	21 standard 25 full	19.1	3.5	1.7	Two 457-mm torpedo tubes Two 25-mm Guns (one twin mount aft)	50	Information not available	2 Diesels 2,200	12

APPENDIX P: ILLUSTRATIONS OF CUBAN AIRCRAFT

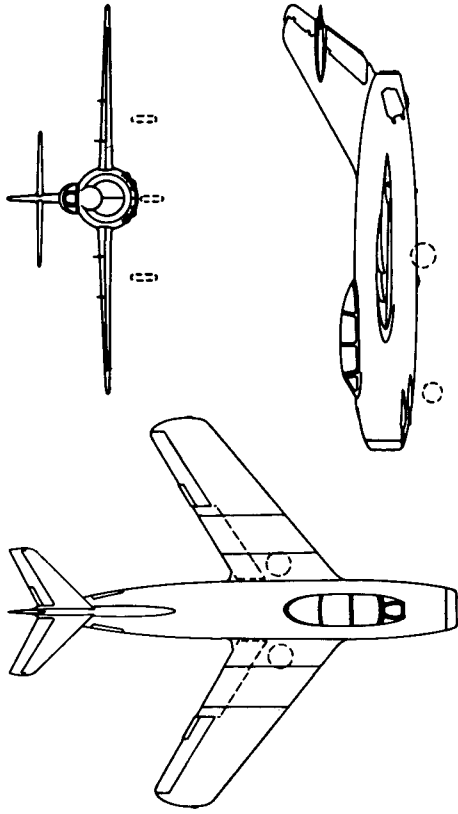

FAGOT/MIG-15

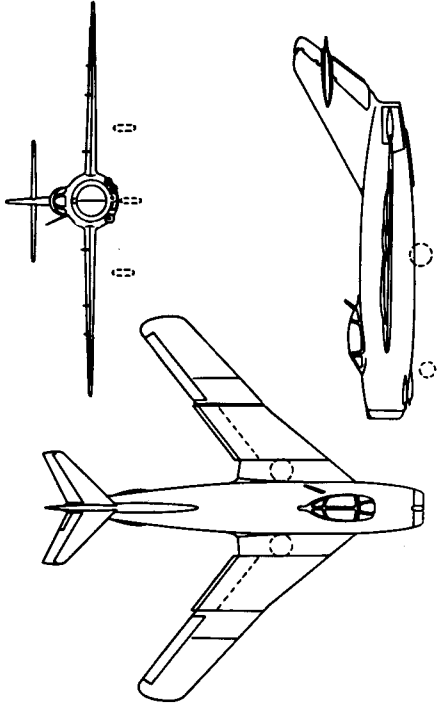

FRESCO/MIG-17

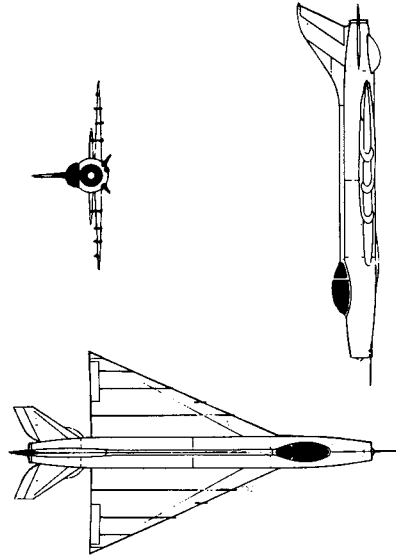

FISHBED/MIG-21

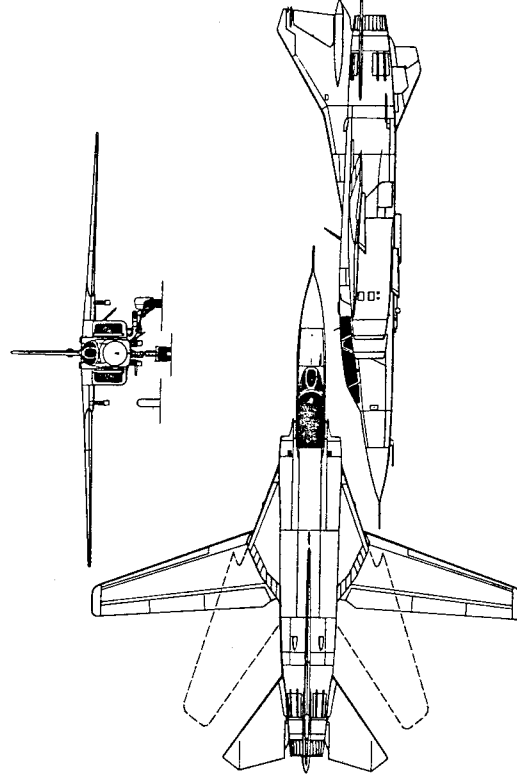

FLOGGER/MIG-23

APPENDIX P: ILLUSTRATIONS OF CUBAN AIRCRAFT (cont)

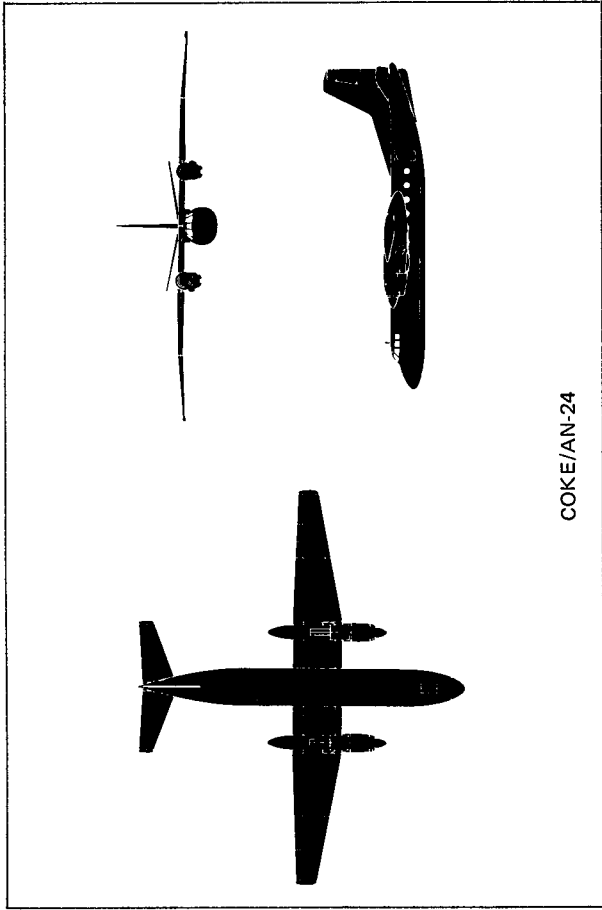

COKE/AN-24

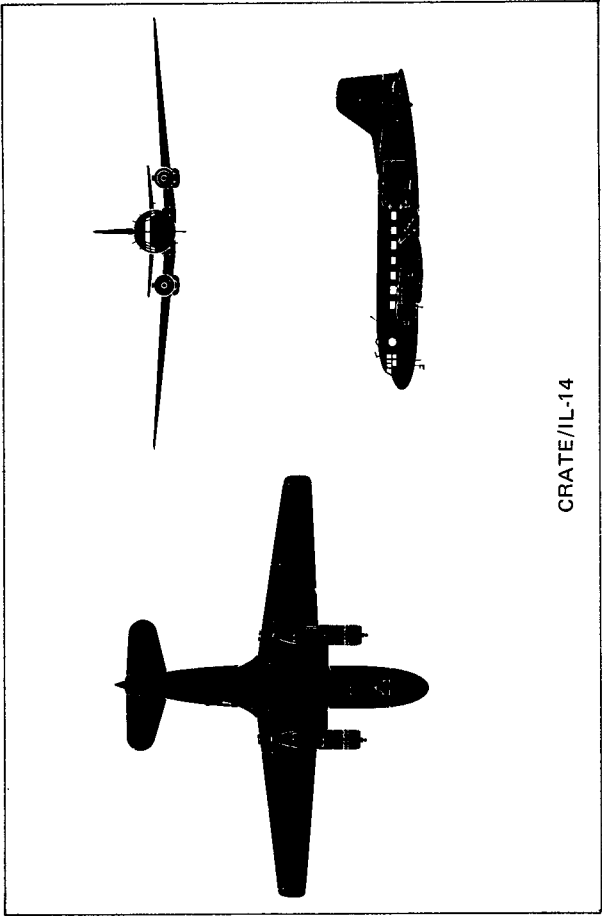

CRATE/IL-14

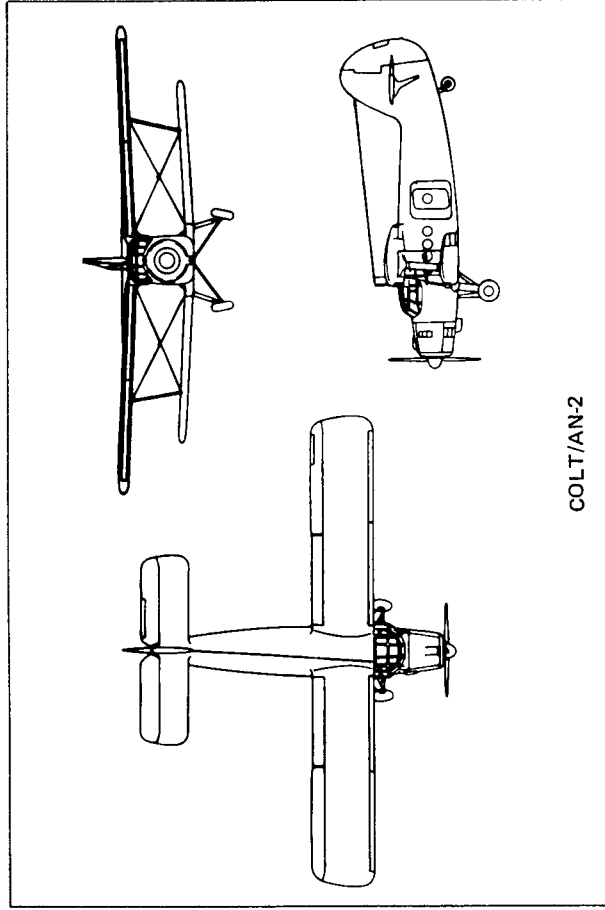

COLT/AN-2

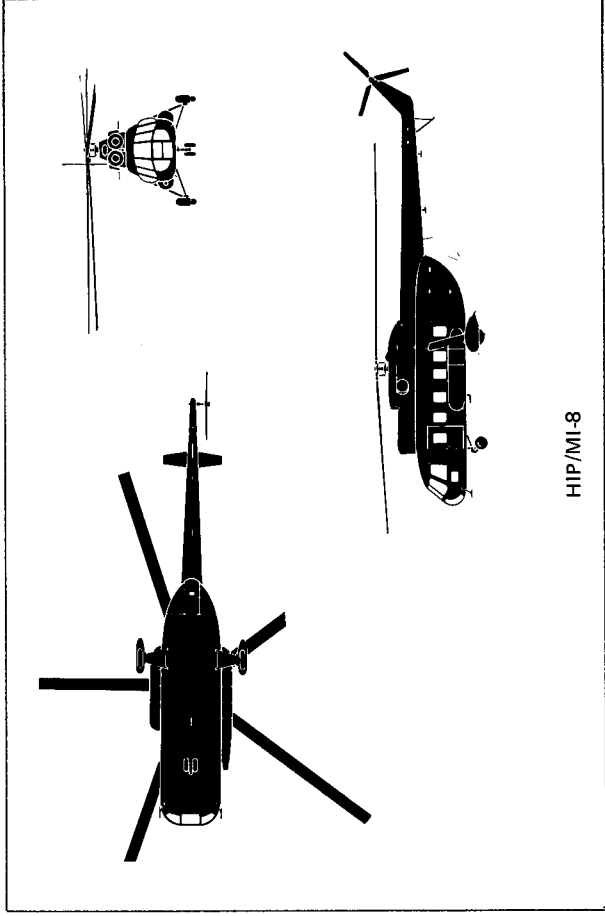

HIP/MI-8

APPENDIX P: ILLUSTRATIONS OF CUBAN AIRCRAFT (cont)

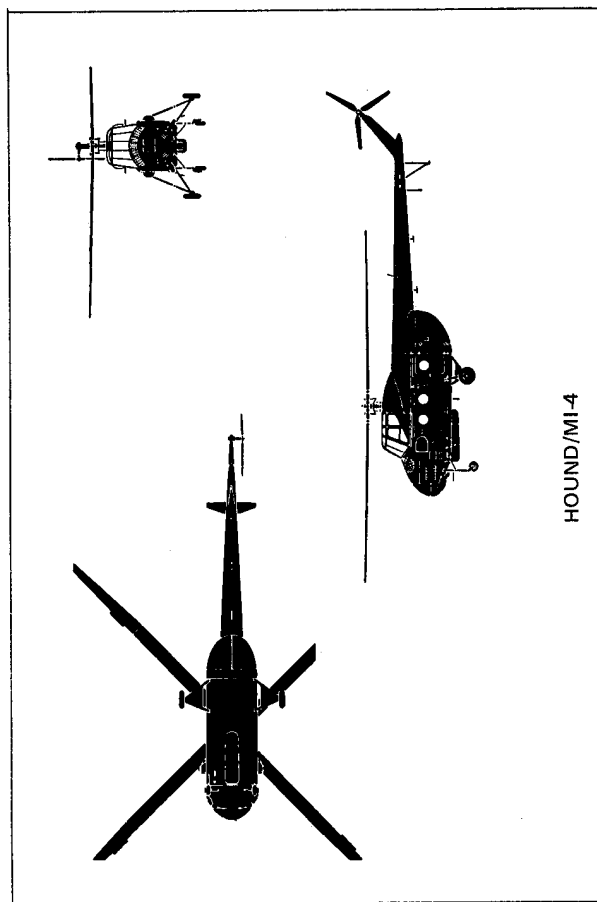

SELECTED TECHNICAL CHARACTERISTICS OF CUBAN AIR FORCE AIRCRAFT

Aircraft	Role	Length (meters)	Wing Span or Rotor Diameter (meters)	Engines	Range (km) (nm)	Radius (km) (nm)	Speed (km/hr) (kn/hr)	Maximum Mission Payload (kg)
<u>Fighters</u> FAGOT/MIG-15	Fighter-bomber	10.1	10.1	1 turbojet	2,129 1,150	278 150	1,083 585 maximum	Cannon and two 250-kg bombs.
FRESCO/MIG-17	Interceptor	11.5	9.5	1 turbojet	1,148 620	519 280	1,055 570 maximum	Cannon and two 250-kg bombs.
FISHBED/MIG-21	Interceptor/ ground attack	13.5	7.2	1 turbojet	1,574 850	667 360	2,230 1,205 maximum	Cannon and two 250-kg bombs.
FLOGGER/MIG-23	Ground attack/ interceptor	16.8	fully spread: 14.3 fully swept: 8.2	1 turbojet	— —	960 520	—	1,900
<u>Transports</u> COKE/AN-24	Short-range	23.5	29.2	2 turboprop	2,398 1,295	— —	450 243 cruise	5,712
CRATE/IL-14	Short-range	22.3	31.7	2 piston	2,165 1,169	— —	323 175 cruise	4,090
COLT/AN-2	Short-range	13.0	18.2	1 piston	904 488	— —	200 108 cruise	1,364
<u>Helicopters</u> HIP/MI-8	Medium-lift/assault	18.3	21.4	2 shaft turbine	424	—	220 119 maximum	4,008
HOUND/MI-4	Medium-lift	16.8	21.0	1 piston	498 269	— —	185 100 maximum	1,602
<u>Trainers</u> MIDGET/UMIG-15	2-seater	10.1	10.1	1 turbojet	—	—	Similar to MIG-15	
MONGOL/UMIG-21	2-seater	13.5	7.2	1 turbojet	—	—	Similar to MIG-21	
ZLIN 326 TRENER-MASTER (Czech)	2-seater	7.8	10.6	1 piston	580 313	— —	243 131 maximum	975

Appendix R
CUBAN SURFACE-TO-AIR MISSILES

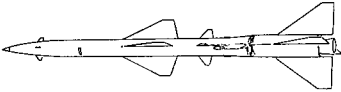
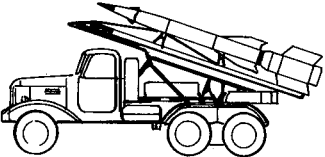
System	Characteristics	Role
<p>SA-2 GUIDELINE</p> 	<p>Transportable medium- to high-altitude SAM system. Six missile launchers per site. One missile per launcher.</p> <p>Approximate slant range: 40 km.</p> <p>Ceiling: 24,400 m.</p>	<p>Air defense</p>
<p>SA-3 GOA</p> 	<p>Transportable low- to medium-altitude SAM system. Carried in pairs on trucks.</p> <p>Approximate slant range: 24 km.</p> <p>Ceiling: 8,000-12,000 m.</p>	<p>Air defense</p>

DISTRIBUTION LIST (PAPER COPY)

DOD AND JOINT AGENCIES

A009 OASD ATOM ENERGY
A048 DEF CIV. PREP AGCY
A117 OASD PA&E
A133 OASD ISA/INTER-AM
A310 JCS/J-3 (SP OP DIV)
A355 US DEL IA DEF BD
A342 JCS/J-5 SAP

DIA

B040 DIA/DIO
B080 DIA/SWS
B100 DIA/DB
B138 DIA/DE-4
B155 DIA/RDS-3A4 PP
B160 DIA/DT-1B
B163 DIA/DT-1A3
B167 DIA/DT-2B
B168 DIA/DT-2C
B169 DIA/DT-2D
B351 DIA/RDS-3D2
B486 DIA/RDS-3A3 ANAC (4)
B545 DIA/VP
B553 DIA/DM-2
B571 DIA/DB-4G1
B594 DIA/DB-1F (2)
B612 DIA/DB-4D2
B617 DIA/DB-3
B629 DIA/DB-3E
B630 DIA/DB-3E2
B631 DIA/DB-3E1 (2)
B632 DIA/DB-4G2
B633 DIA/DB-4G3
B639 DIA/DN-2D2
B649 DIA/DB-4F2
B737 DIA/RDS-3B3 (LIB) (5)
B252 DIA/RSS-3B
B542 DIA/DB-4E2
B544 DIA/DB-4E4
B728 DIA/DB-5D
B800 DIA/DL-1 LONDON
B810 DIA/DL-2 OTTAWA

DIA (CONT'D)

B811 DIA/DL-3 CANBERRA
B812 DIA/DL-4 FRG

ARMY

C020 DCS-OPS & PLANS (4)
C227 101ST AIRBORNE DIV
C231 2ND ARM DIV
C239 11TH MI CO
C301 193RD INF BDE (CZ)
C303 4TH PSYOP GROUP
C305 18TH ABN CORPS
C306 82ND ABN DIV
C307 24TH INF DIV
C419 9TH INF DIV
C428 OP TEST&EVAL AGCY
C454 FLD ARTY SCH
C461 INFANTRY SCH
C464 ACADEMY HEALTH SCI
C470 ARMY WAR COL
C507 GIPD
C513 ARRADCOM
C515 CHEMICAL SYS LAB
C535 AVRADCOM/TSARCOM
C539 TRASANA
C557 USAITAC (IAX-OI-I)
C590 TARDC
C591 FSTC (3)
C605 JFK CTR MIL ASSIST
C619 MIA REDSTONE
C620 USAITAC (IAX-OT-C)
C632 ORD&CHEM CTR & SCH
C641 AVIATION SCHOOL
C646 CMBARMSCMBTDEVACTY
C683 INTEL CTR&SCH
C759 DO INSCOM
C763 HQDA DAMI-FIT
C765 USAITAC (IAX-TA-C)
C766 USAITAC (IAX-OI-D)
C768 USAITAC (IAX-SO-I)
C786 HQDA DAMI-FIW
C414 4TH INF DIV
C553 COMMUNICATIONS CMD

NAVY

D007 NIS HQ (CODE 27)
D008 NISC (2)
D035 OP-09BH-AR
D150 CMC (INT)
D151 NAVEODFAC IND HEAD
D152 NISC CBD DET 0003
D153 PACMISTESTCEN
D159 NAVAIRDEVCCEN
D202 NAVWARCOL
D220 ONR
D248 NAVSEASYSYSCOM
D249 NAVPGSCOL
D261 NUSC NPT
D263 NOSC
D275 OP-951D2
D510 CHNAVMAT (MAT-09I)
D511 NAVAIRSYSCOM
D560 NMEDRSCHINST BETH
D605 NAVELECSYSCOM
D700 CGMCDEC
D766 NAVCOASTSYSCEN
D911 NOSIC
D941 OP-955D
D971 OP-009F
D972 OP-009U
D058 OP-604
D218 NRL WASH DC
D562 NISCSPAWEP 0108

AIR FORCE

E010 AFIS/INDOC
E046 7602 AINTELG/INIC
E054 AF/INER
E100 TAC (460 RTS/LDD) (7)
E104 USAF TFWC/IN
E226 AFOSI/IVOA
E293 AF/XOORE
E317 AF/PACRI
E323 AF/XOXXW
E411 ASD/FTD/NIIS
E420 FTD/NIIS
E429 SAMSO (IND)
E436 AFEWC/EST
E451 AUL/LSE
E560 6944 SCTYW

AIR FORCE (CONT'D)

E561 6947 SCTYS
E562 6947 SCTYS (OL BB)
E401 AFLC/IN (2)

U & S COMMANDS

J005 CINCLANT
J006 COMLANTCOMELINTCEN
J009 JUWTFA
J500 CINCLANTFLT
J501 USCOMSOLANT
J515 FICEURLANT
J517 COMNAVSURFLANT
J522 COMNAVBASE GTMO
J525 COMNAVFORCARIB
J575 FMFLANT
J576 COMPHIBGRU 2
J650 AIRTEVRON 1

K300 IPAC (LIBRARY)
K315 IPAC (CODE I-4)
K500 CINCPACFLT
K516 FIRST MAF
K605 FMFPAC
K610 FIRSTMARDIV
K650 COMNAVSURFPAC

L043 544 IAS/IAT

M005 USCINCSO
M310 SEC ASST FOR LA
M500 NAVSTA PANAMA CANL
M100 24 COMPW/IN

N005 USREDCOM

OTHER

P005 DOE/DDI
P055 CIA/OCR/ADD/SD (14)
P085 STATE (7)
P090 NSA (5)

OTHER (CONT'D)

S030 FRD LIB OF CONG (10)

TOTAL DIA DISTRIBUTION:	<u>214</u>	COPIES
DIA STOCK:	<u>151</u>	COPIES
TOTAL PRINT:	<u>365</u>	COPIES

DISTRIBUTION LIST (MICROFICHE)

DIA

B352 DIA/RDS-3A2C STOCK (5)
B331 DIA/RDS-3A2
B788 DIA/DN-2C1

ARMY

C202 III CORPS
C303 4TH PSYOP GROUP
C305 18TH ABN CORPS
C454 FLD ARTY SCH
C591 FSTC
C619 MIA REDSTONE
C562 TRANS SCH

NAVY

D258 DTNSRDC
D914 OP-944C

AIR FORCE

E420 FTD/NIIS (4)
E401 AFLC/IN

U & S COMMANDS

G113 24TH AIR DIVISION

J501 USCOMSOLANT
J515 FICEURLANT
J575 FMFLANT

K516 FIRST MAF
K650 COMNAVSURFPAC

L042 544 IAS/IAE
L043 544 IAS/IAT
L044 544 IAS/IATR

TOTAL PRINT: 30 COPIES