

ADR

87016 R04

106-850816

Contract DAAK11-83-D-0007
Task Order 0006

**ROCKY MOUNTAIN ARSENAL OFFPOST CONTAMINATION ASSESSMENT
TECHNICAL PLAN
A003**

ENVIRONMENTAL SCIENCE AND ENGINEERING, INC.
7332 S. Alton Way, Suite H
Englewood (Denver), Colorado 80112

August 16, 1985
Revision A

Distribution limited to U.S. Government Agencies only for protection of privileged information evaluating another command: September 1984. Requests for this document must be referred to: Commander, U.S. Army Toxic and Hazardous Material Agency, Aberdeen Proving Ground, Md. 21010

Prepared for:

U.S. ARMY TOXIC AND HAZARDOUS MATERIALS AGENCY
Assessments Division
Aberdeen Proving Ground, Md. 21010

19950118 041

THE VIEWS, OPINIONS, AND/OR FINDINGS CONTAINED IN THIS REPORT ARE THOSE OF THE AUTHOR(S) AND SHOULD NOT BE CONSTRUED AS AN OFFICIAL DEPARTMENT OF THE ARMY POSITION, POLICY, OR DECISION, UNLESS SO DESIGNATED BY OTHER DOCUMENTATION.

THE USE OF TRADE NAMES IN THIS REPORT DOES NOT CONSTITUTE AN OFFICIAL ENDORSEMENT OR APPROVAL OF THE USE OF SUCH COMMERCIAL PRODUCTS. THIS REPORT MAY NOT BE CITED FOR PURPOSES OF ADVERTISEMENT.

REPORT DOCUMENTATION PAGE

Form Approved
OMB No. 0704-0188

Public reporting burden for this collection of information is estimated to average 1 hour per response, including the time for reviewing instructions, searching existing data sources, gathering and maintaining the data needed, and completing and reviewing the collection of information. Send comments regarding this burden estimate or any other aspect of this collection of information, including suggestions for reducing this burden, to Washington Headquarters Services, Directorate for Information Operations and Reports, 1215 Jefferson Davis Highway, Suite 1204, Arlington, VA 22202-4302, and to the Office of Management and Budget, Paperwork Reduction Project (0704-0188), Washington, DC 20503.

1. AGENCY USE ONLY (Leave blank)		2. REPORT DATE 08/16/85	3. REPORT TYPE AND DATES COVERED	
4. TITLE AND SUBTITLE ROCKY MOUNTAIN ARSENAL, OFFPOST CONTAMINATION ASSESSMENT, TECHNICAL PLAN A003 (REVISION A)			5. FUNDING NUMBERS	
6. AUTHOR(S)			DAAK11 83 D 0007	
7. PERFORMING ORGANIZATION NAME(S) AND ADDRESS(ES) ENVIRONMENTAL SCIENCE AND ENGINEERING DENVER, CO			8. PERFORMING ORGANIZATION REPORT NUMBER 87016R04	
9. SPONSORING/MONITORING AGENCY NAME(S) AND ADDRESS(ES) ROCKY MOUNTAIN ARSENAL (CO.). PMRMA COMMERCE CITY, CO			10. SPONSORING/MONITORING AGENCY REPORT NUMBER	
11. SUPPLEMENTARY NOTES				
12a. DISTRIBUTION / AVAILABILITY STATEMENT APPROVED FOR PUBLIC RELEASE; DISTRIBUTION IS UNLIMITED			12b. DISTRIBUTION CODE	
13. ABSTRACT (Maximum 200 words) <p>THE OBJECTIVES OF THE OFF-POST CONTAMINATION ASSESSMENT ARE TO DETERMINE:</p> <ol style="list-style-type: none"> 1. EXISTENCE AND/OR EXTENT OF CONTAMINATION MIGRATION 2. EFFECTS OF SUCH CONTAMINATION ON THE HUMAN ENVIRONMENT. <p>THIS TECHNICAL PLAN DESCRIBES THE PROCEDURES, EQUIPMENT, AND RATIONALE FOR THE FOLLOWING WORK ELEMENTS:</p> <ol style="list-style-type: none"> 1. GEOTECHNICAL DATA COLLECTION AND EVALUATION 2. SURFACE AND GROUND WATER SAMPLING 3. CHEMICAL ANALYSIS 4. DATA ANALYSIS 5. CONTAMINATION ASSESSMENT 6. DOCUMENT PREPARATION. <p>GROUND WATER MONITORING IS THE MAJOR TASK UNDER THIS PLAN OF STUDY, AND THE KEY ELEMENT OF THE TECHNICAL PLAN WILL BE TO DETAIL PROCEDURES FOR ESTABLISHING AND OPERATING THE GROUND WATER NETWORK. THIS WILL INCLUDE:</p>				
14. SUBJECT TERMS GEOPHYSICAL PROGRAM, SOIL SAMPLING, CHEMICAL ANALYSIS			15. NUMBER OF PAGES	
			16. PRICE CODE	
17. SECURITY CLASSIFICATION OF REPORT UNCLASSIFIED	18. SECURITY CLASSIFICATION OF THIS PAGE	19. SECURITY CLASSIFICATION OF ABSTRACT	20. LIMITATION OF ABSTRACT	

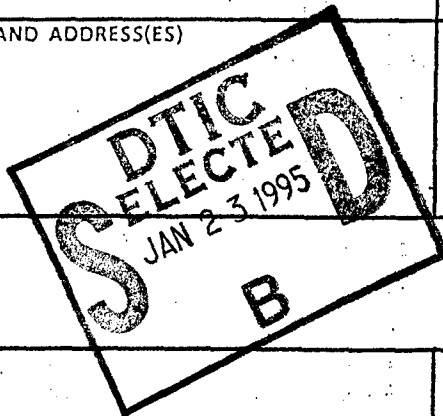

T06-850816

Contract DAAK11-83-D-0007
Task Order 0006

**ROCKY MOUNTAIN ARSENAL OFFPOST CONTAMINATION ASSESSMENT
TECHNICAL PLAN
A003**

ENVIRONMENTAL SCIENCE AND ENGINEERING, INC.
7332 S. Alton Way, Suite H
Englewood (Denver), Colorado 80112

August 16, 1985
Revision A

Distribution limited to U.S. Government Agencies only for protection of privileged information evaluating another command. September 1984.
Requests for this document must be referred to: Commander, U.S. Army Toxic and Hazardous Material Agency, Aberdeen Proving Ground, Md. 21010

Prepared for:

U.S. ARMY TOXIC AND HAZARDOUS MATERIALS AGENCY
Assessments Division
Aberdeen Proving Ground, Md. 21010

DISCLAIMER NOTICE



THIS DOCUMENT IS BEST QUALITY AVAILABLE. THE COPY FURNISHED TO DTIC CONTAINED A SIGNIFICANT NUMBER OF PAGES WHICH DO NOT REPRODUCE LEGIBLY.

TABLE OF CONTENTS

<u>Section</u>		<u>Page</u>
1.0	INTRODUCTION AND BACKGROUND	1-1
1.1	<u>STATEMENT OF THE PROBLEM</u>	1-3
	1.1.1 CONTAMINANTS	1-5
	1.1.2 CONTAMINATION SOURCES	1-5
	1.1.3 RESPONSES ACTIONS	1-8
	1.1.4 STUDY AREA	1-12
	1.1.5 TOPOGRAPHY AND SURFACE WATER HYDROLOGY	1-15
	1.1.6 GEOLOGY AND GEOHYDROLOGY	1-15
	1.1.7 WATER QUALITY	1-21
	1.1.8 METEOROLOGY AND AIR QUALITY	1-26
	1.1.9 BIOTA	1-27
1.2	<u>GENERAL APPROACH</u>	1-27
1.3	<u>ORGANIZATION OF THE TECHNICAL AND MANAGEMENT PLANS</u>	1-29
2.0	CONSUMPTIVE USE WATER WELL SAMPLING	2-1
2.1	<u>SAMPLING NETWORK</u>	2-1
	2.1.1 CONSUMPTIVE USE WATER WELL SAMPLING	2-1
	2.1.2 FIELD VERIFICATION OF CANDIDATE WELLS	2-19
2.2	<u>FIELD SAMPLING OF CONSUMPTIVE USE WELLS</u>	2-21
2.3	<u>SAMPLE SHIPMENT/CHAIN OF CUSTODY</u>	2-26
3.0	GEOTECHNICAL PROGRAM	3-1
3.1	<u>MONITOR WELL NETWORK AND RATIONALE</u>	3-1
	3.1.1 WELL LOCATION RATIONALE	3-1
3.2	<u>ANTICIPATED CONDITIONS</u>	3-5
3.3	<u>SURFACE GEOPHYSICS</u>	3-29
3.4	<u>INITIATION OF FIELD PROGRAM</u>	3-29
3.5	<u>SOIL SAMPLING</u>	3-32
	3.5.1 BOREHOLE DESCRIPTION	3-33
	3.5.2 DRILLING TECHNIQUES	3-41
3.6	<u>BOREHOLE GEOPHYSICS</u>	3-42
3.7	<u>ABANDONMENT</u>	3-43
3.8	<u>WELL INSTALLATION</u>	3-45
	3.8.1 WELL SCREENS, CASINGS AND FITTINGS	3-47
	3.8.2 GRANULAR BACKFILL	3-48

For	
I	<input checked="" type="checkbox"/>
d	<input type="checkbox"/>
ion	<input type="checkbox"/>

Availability Codes	
Dist	Avail and/or Special
A-1	

TABLE OF CONTENTS
(Continued, Page 2 of 3)

<u>Section</u>	<u>Page</u>
3.8.3 BENTONITE SEAL	3-51
3.8.4 GROUT SEAL	3-52
3.8.5 PROTECTIVE CASING	3-52
3.8.6 WELL DEVELOPMENT	3-55
3.8.7 WELL ACCEPTANCE CRITERIA	3-60
3.8.8 WELL CONSTRUCTION DIAGRAMS	3-61
3.9 <u>CLEANING PROCEDURES AND MATERIAL DISPOSAL</u>	3-62
3.10 <u>SURVEYING</u>	3-63
3.11 <u>HYDROGEOLOGIC DATA AQUISITION</u>	3-64
3.11.1 WATER LEVELS	3-64
3.11.2 PERMEABILITY TESTING	3-64
3.11.3 AQUIFER TESTING	3-65
4.0 GROUND WATER SAMPLING	4-1
4.1 <u>SAMPLING NETWORK</u>	4-1
4.2 <u>SAMPLE SHIPMENT/CHAIN OF CUSTODY</u>	4-4
5.0 SURFACE WATER AND STREAM SEDIMENT SAMPLING	5-1
5.1 <u>SAMPLE STATION LOCATIONS</u>	5-1
5.2 <u>FLOW MEASUREMENT</u>	5-3
5.3 <u>SAMPLE COLLECTION</u>	5-4
5.3.1 SURFACE WATER	5-4
5.3.2 SEDIMENTS	5-5
5.4 <u>SAMPLE PRESERVATION PROCEDURES</u>	5-6
6.0 CHEMICAL ANALYSIS PROGRAM	6-1
6.1 <u>CHEMICAL ANALYSIS SCHEDULE</u>	6-1
6.2 <u>CHEMICAL ANALYSIS METHODS</u>	6-1
7.0 QUALITY ASSURANCE	7-1
7.1 <u>FIELD LABORATORY QA PROGRAM</u>	7-1
7.2 <u>SPECIFIC RMA REQUIREMENTS</u>	7-2
7.2.1 FIELD PROCEDURES	7-2
7.2.2 SAMPLE PREPARATION AND BATCHING	7-2
7.2.3 HOLDING TIMES	7-3
7.2.4 DETECTION LIMITS, ACCURACY, PRECISION AND CERTIFICATION	7-3
7.2.5 ANALYTICAL CONTROLS	7-3
7.2.6 REVIEWING AND REPORTING REQUIREMENTS	7-6

TABLE OF CONTENTS
(Continued, Page 3 of 3)

<u>Section</u>		<u>Page</u>
8.0	BIOTA MONITORING	8-1
	8.1 <u>PILOT STUDY</u>	8-2
	8.2 <u>CAPTURE PHASE</u>	8-3
	8.3 <u>FALL MONITORING</u>	8-4
	8.4 <u>WINTER MONITORING</u>	8-5
	8.5 <u>DATA PROCESSING AND REPORT PREPARATION</u>	8-6
9.0	CONTAMINATION ASSESSMENT	9-1
10.0	REPORT PRODUCTION	10-1
	10.1 <u>ADMINISTRATIVE REPORTS</u>	10-1
	10.2 <u>TECHNICAL REPORTS</u>	10-1
	10.3 <u>QUALITY ASSURANCE/QUALITY CONTROL</u>	10-2
	BIBLIOGRAPHY	
	APPENDIX A-- ESE FIELD LABOTATORY AND QUALITY ASSURANCE PROGRAM PLAN	A-1

LIST OF FIGURES

<u>Figure</u>		<u>Page</u>
1.1-1	Location Map	1-4
1.1-2	Sources of Contamination	1-7
1.1-3	Study Area Boundaries	1-13
1.1-4	Drainage Basins	1-16
1.1-5	Geologic Setting of Rocky Mountain Arsenal	1-17
1.1-6	Upper Stratigraphic Section of Denver Basin	1-19
1.1-7	Potentially Contaminated Offpost Areas	1-20
2.1-1	Potential Consumptive Use Sample Locations	2-8
2.1-2	Parcels Identifications and Areas of Elevated Concern	2-16
2.1-3	RMA Offpost Field Data Sheet	2-22
2.1-4	USATHAMA Data Management System Information Requirements	2-23
3.1-1	Proposed Monitor Well Locations	3-2
3.5-1	Field Log of Boring	3-34
3.5-2	Record of Activities at Drill Site	3-36
3.7-1	Borehole or Well Abandonment Report	3-46
3.8-1	Shallow (Alluvial) Monitor Well Construction	3-49
3.8-2	Deep (Denver Formation) Monitor Well Construction	3-50
3.8-3	Surface Protection for Monitor Well	3-54
3.8-4	Post Placement Around Wells	3-56
3.8-5	Well Development Field Data	3-58
5.0-1	Proposed Surface Water Sampling Sites	5-2
10.3-1	Deliverable Review Sheet	10-3

LIST OF TABLES

<u>Table</u>		<u>Page</u>
1.1-1	Chemical Analysis Methods	1-22
2.1-1	Original 360° Program Analytical Schedule	2-3
2.1-2	360° Program Wells	2-5
2.1-3	Army Deep Wells	2-9
2.1-4	Well Sampling Priority by Parcel	2-11
2.1-5	Numerical Distribution of 125 Consumptive Use Wells	2-18
2.1-6	Bedrock/Multi-Use Well Sampling Locations	2-20
3.2-1	Land Ownership at Proposed Well Locations	3-24
3.2-2	List of Property Owners Adjacent to Proposed Well Drilling Sites	3-25
3.2-3	Listing of Buried Utility Lines Adjacent to Drilling Sites	3-28
6.0-1	Contaminants to be Analyzed During Assessment	6-2
6.1-1	Chemical Analysis Schedule	6-3
6.2-1	Analytical Methods and Certification Status for Aqueous Samples	6-4
6.2-2	Analytical Laboratory Performing Analysis of the Drilling and Consumptive Use Ground Water Samples	6-6
6.2-3	Present and Anticipated Certified Detection Limits	6-7
6.2-4	Compounds Considered as Contaminants for RMA Study and Status of Toxicology Data Availability	6-8
7.2-1	Sample Containers, Preservation and Holding Times	7-4
7.2-2	QC Data Reporting Requirements for RMA	7-5

LIST OF ACRONYMS AND ABBREVIATIONS

(Page 1 of 3)

ASTM	American Society for Testing Materials
CDH	Colorado Department of Health
CDOW	Colorado Department of Wildlife
CDWR	Colorado Division of Water Resources
CEO	Colorado State Engineers Office
CERCLA	Comprehensive Environmental Response, Compensation, and Liability Act of 1980
CF&I	Colorado Fuel and Iron Corporation
cm	Centimeters
COE	U.S. Corp of Engineers
°C	degrees Centigrade
DBCP	Dibromochloropropane
DCPD	Dicyclopentadiene
DDT	Dichlorodiphenyltrichloroethane
DIMP	Diisopropylmethylphosphonate
DMMP	Dimethylmethylphosphonate
DMS	Data Management System
DOD	U.S. Department of Defense
DOT	U.S. Department of Transportation
EPA	U.S. Environmental Protection Agency
ESE	Environmental Science and Engineering, Inc.
FDI	Fox Drilling, Inc.
FIT	Field Investigation Team
g	grams
gal	gallon(s)
GSA	Geological Society of America
ha	hectares
ITECH	International Technology Limited
km	kilometers

LIST OF ACRONYMS AND ABBREVIATIONS

(Continued, Page 2 of 3)

km/h	kilometers per hour
lb	pounds
m	meters
μ	micron
$\mu\text{g/g}$	microgram per gram
MER	Master Extract Register
ml	milliliter
mm	millimeters
MOA	Memorandum of Agreement
MRI	Midwest Research Institute
NCP	National Contingency Plan
OD	outside diameter
PCPMS	p-chlorophenylmethysulfide
PCPMSO	p-chlorophenylmethysulfoxide
PPLV	Preliminary Pollutant Limit Value
PCPMSO ₂	p-chlorophenylemethysulfone
PM-CDIR	Project Manager Chemical Demilitarization Installation Restoration
ppm	parts-per-million
psi	pounds-per-square-inch
PVC	polyvinyl chloride
QA	Quality Assurance
QC	Quality Control
RCRA	Resource Conservation and Recovery Act
RMA	Rocky Mountain Arsenal
SACWSD	South Adams County Water and Sanitation District
Shell	Shell Oil Company
SRSD	Stratified Random Sampling Design
TCDHD	Tri-County District Health Department

LIST OF ACRONYMS AND ABBREVIATIONS

(Continued, Page 3 of 3)

USAEHA	U.S. Army Environmental Hygiene Agency
USAMBRDL	U.S. Army Medical and Bioengineering Research and Development Laboratory
USATHAMA	U.S. Army Toxic and Hazardous Materials Agency
USGS	U.S. Geological Survey
UTM	Universal Transverse Mercator
WES	Waterways Experiment Station
WSSI	Western States Surveying, Inc.
WWII	World War II

1.0 INTRODUCTION AND BACKGROUND

The primary authorization for an offpost assessment at the Rocky Mountain Arsenal (RMA) is the Army's response authority under the Comprehensive Environmental Response, Compensation, and Liability Act of 1980 (CERCLA). As delegated by Executive Order 12316, the Army is responsible for determining response measures, consistent with the National Contingency Plan (NCP), deemed necessary to protect public health, welfare, or the environment from releases of hazardous substances, pollutants, or contaminants from Army facilities. This authority includes the responsibility under Section 104(b) of CERCLA to undertake such investigation, monitoring, surveys, testing, and other information gathering as necessary to identify the extent of a release, the source and nature of contamination, and the extent of danger to the public health, welfare, or the environment. Army actions under CERCLA are required to be consistent with the NCP, 40 C.F.R. Part 300, and the Memorandum of Understanding between the U.S. Department of Defense (DOD) and the U.S. Environmental Protection Agency (EPA) for implementation of CERCLA.

To promote consultation and cooperation in implementing its CERCLA responsibilities at RMA, the Army entered into a Memorandum of Agreement (MOA) on December 6, 1982, with the EPA, Colorado Department of Health (CDH), and Shell Oil Company (Shell). The MOA committed the Army to provide an initial offsite contamination assessment report based on existing monitoring data.

RMA prepared the assessment as required by Section 300.64 of the NCP and Section II.A of the MOA. That report was distributed to MOA parties in June 1983. Further Army offpost responsibilities are determined by Section 300.68 of the NCP. Under this section, the Army is required to conduct a remedial investigation and a feasibility study, if offsite remedial action is determined to be appropriate.

The U.S. Army Toxic and Hazardous Materials Agency (USATHAMA) has issued Contract No. DAAK11-83-D-0007, Task Order 0006 to Environmental Science

and Engineering, Inc. (ESE) to perform tasks at RMA to determine the existence and/or extent of contaminant migration, and the effect of such contamination on the human environment. The technical plan is presented in this document and describes the details, procedures, methodology, equipment and rationale for the technical effort in the work elements of geotechnical data collection and evaluation, surface and ground water sampling, chemical analysis, data analysis and contamination assessment, and document preparation.

Sections 1.0 through 10.0 present the technical plan that is specific to the RMA Contamination Assessment. As support to the plan, Appendix A has been added that addresses general procedures under Contract No. DAAK-83-D-0007. Specific work items in the work plan (Section 1.0 through 10.0) supercede methodology presented as general overall procedures described in this Appendix.

When completed and approved, the Technical Plan will serve as a reference document for personnel conducting field activities, data analysis, and report preparation. Ground water monitoring is the major task under this plan of study, and thus, the key element of the Technical Plan will be to detail procedures for establishing and operating the ground water network. This will include site selection, drilling, logging, borehole geophysics, well installation, well development, surveying, water sampling, and water level measurements. Other plan elements will describe shipping protocol, chain of custody, and analysis procedures.

The objective of the technical evaluation of data collected during implementation of the Technical Plan include:

1. Determination of the persistence and rate of movement of the contaminants;
2. Assisting U.S. Army Medical and Bioengineering Research and Development Laboratory (USAMBRDL) in the establishment of preliminary pollutant limit values (PPLVs) for contaminants of concern;
3. Identification of the contaminant transport pathways that might result in significant human exposure; and

4. Determination of the quantity of contaminants present in environmental media to which humans are exposed.

When complete this study will play an integral role in determining whether offsite remedial actions are required and, if so, provide a sufficient data base for the development of remedial action alternatives.

This Technical Plan is supported by the Management Plan, which details the project organization and management procedures to be used to ensure the cost-effective and timely achievement of the technical objectives.

1.1 STATEMENT OF THE PROBLEM

RMA occupies over 6,880-hectares (ha) in Adams County, Colorado (Figure 1.1-1). RMA is located approximately 14- to 16-kilometers (km) northeast of the center of downtown Denver.

The property occupied by RMA was purchased by the government in 1942. Throughout World War II (WW II), RMA manufactured and assembled chemical intermediate and toxic end-item products and incendiary munitions.

During the period 1945 to 1950, RMA distilled available stocks of Levinstein mustard, demilitarized several million rounds of mustard-filled shells, and test-fired 10.7 centimeters (cm) mortar rounds filled with smoke and high explosives. Also, many different types of obsolete WW II ordinance were destroyed by detonation or burning.

In 1947, certain portions of RMA were leased to the Colorado Fuel and Iron Corporation (CF&I) for chemical manufacturing. CF&I manufactured chlorinated benzenes and dichlorodiphenyltrichloroethane (DDT). Julius and Company assumed the CF&I lease in 1950 and Hyman produced several pesticides. Shell later assumed the pesticide and herbicide manufacturing operations.

Later, RMA was selected as the site for construction of a facility to produce GB agent. This facility was completed in 1953, with the manufacturing operation continuing until 1957, and the munitions filling operations continuing until late 1969.

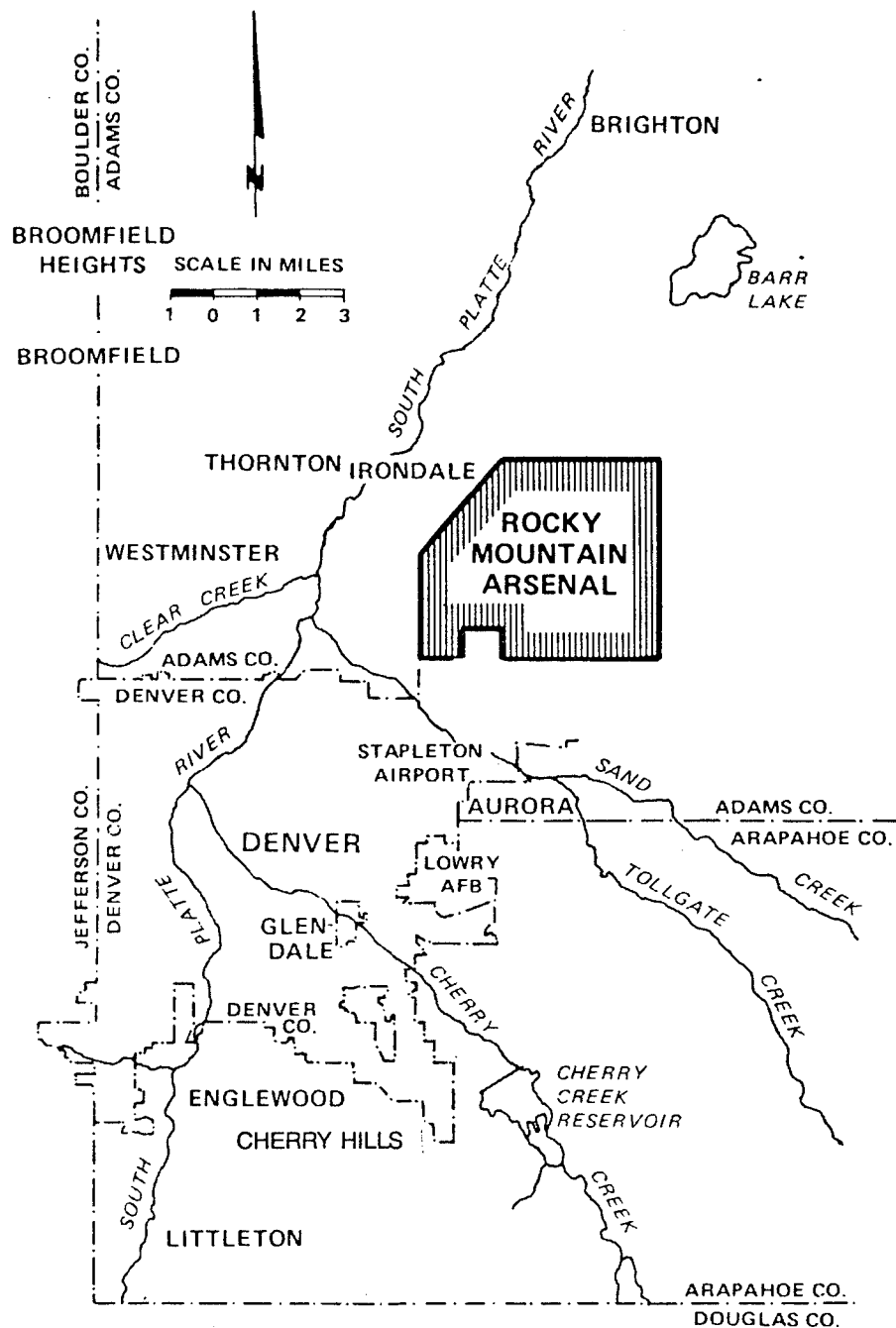

Figure 1.1-1
Location Map

Source: RMA, 1983

Prepared for:
**U.S. Army Toxic and Hazardous
Materials Agency**
Aberdeen Proving Ground, Maryland

Since 1970, RMA has been involved primarily with the disposal of chemical warfare material. This disposal included the incineration of TX anti-crop agent, mustard agent, explosive components, and the destruction of GB agent and related munitions casings by caustic neutralization and incineration.

There are numerous sites on RMA where hazardous wastes have been deposited. Industrial waste effluents generated at RMA were routinely discharged to unlined evaporation basins. Solid wastes have been buried at various locations throughout RMA. Unintentional spills of raw materials, intermediate and final products have occurred within the manufacturing complexes at RMA. Contaminants from these sites have occasionally entered mobile media (ground water, surface water, air or wildlife) and have been transported off the RMA limits.

1.1.1 CONTAMINANTS

Presented below is a listing of the compounds and chemical species that have been identified as ground water contaminants on RMA by the U. S. Army Corps of Engineers (COE) Waterways Experiment Station (WES) (Spaine and Thompson, 1983).

- o Volatile Organics
- o Chlorinated Pesticides (aldrin, dieldrin, endrin, isodrin)
- o Dibromochloropropane (DBCP)
- o Diisopropylmethylphosphonate (DIMP)
- o Dicyclopentadiene (DCPD)
- o Chloride
- o Fluoride
- o 1,4-Dithiane/1,4-Oxathiane
- o p-Chlorophenylmethyl Sulfone (PCPMSO₂)/Sulfoxide (PCPMSO)/Sulfide (PCPMS)

This Technical Plan will focus on detection of these contaminants.

1.1.2 CONTAMINATION SOURCES

As a result of RMA ground water flow studies and chemical analyses of soil and water samples, a series of contaminant sources on RMA have been

identified (Thompson, et al, 1983). Figure 1.1-2 shows the locations of these areas. The following description summarizes each area in general terms as to the types of chemicals found:

Basin A/South Plants - contains wastes and raw chemical from Army and lessees production operations. Typical chemicals include: benzene, DCPD, DBCP, DIMP, heavy metals, various solvents, pesticides, unexploded ordnance, and surety materials.

Basin F - an industrial, lined (but leaking) waste basin containing Army and lessees waste material. Chemicals found include DIMP, chloride, dieldrin, endrin, sulfate, sodium, dyes, heavy metals (such as copper), and many unidentified organic chemicals.

Rail Classification Yard - a suspected source of DBCP that possibly resulted from leaking rail tank cars.

Sanitary Sewer System - has interacted with contaminated ground water and serves as a transport mechanism for chemicals found in the Basin A/South Plants Area.

Chemical Sewer System - has presumably allowed chemical contaminants to enter the ground water in manufacturing areas, near waste storage basins, and along vitrified clay pipes.

Lower Lakes - were used as part of the industrial cooling water and were the site of a spill of aldrin and dieldrin. In addition, mercury has been identified in the sediments. Most of the contamination residues in the lake sediments are in parts-per-million (ppm) concentrations.

Basins C, D, and E - received discharge from the overflow of Basin A. Analysis has shown high concentrations of DIMP, PCPMSO₂ compounds, and high salt concentrations.

Rod and Gun Club Pond - a pond formed in a low area when the lower lakes and an adjacent stream were breached by flood. Contamination is the same

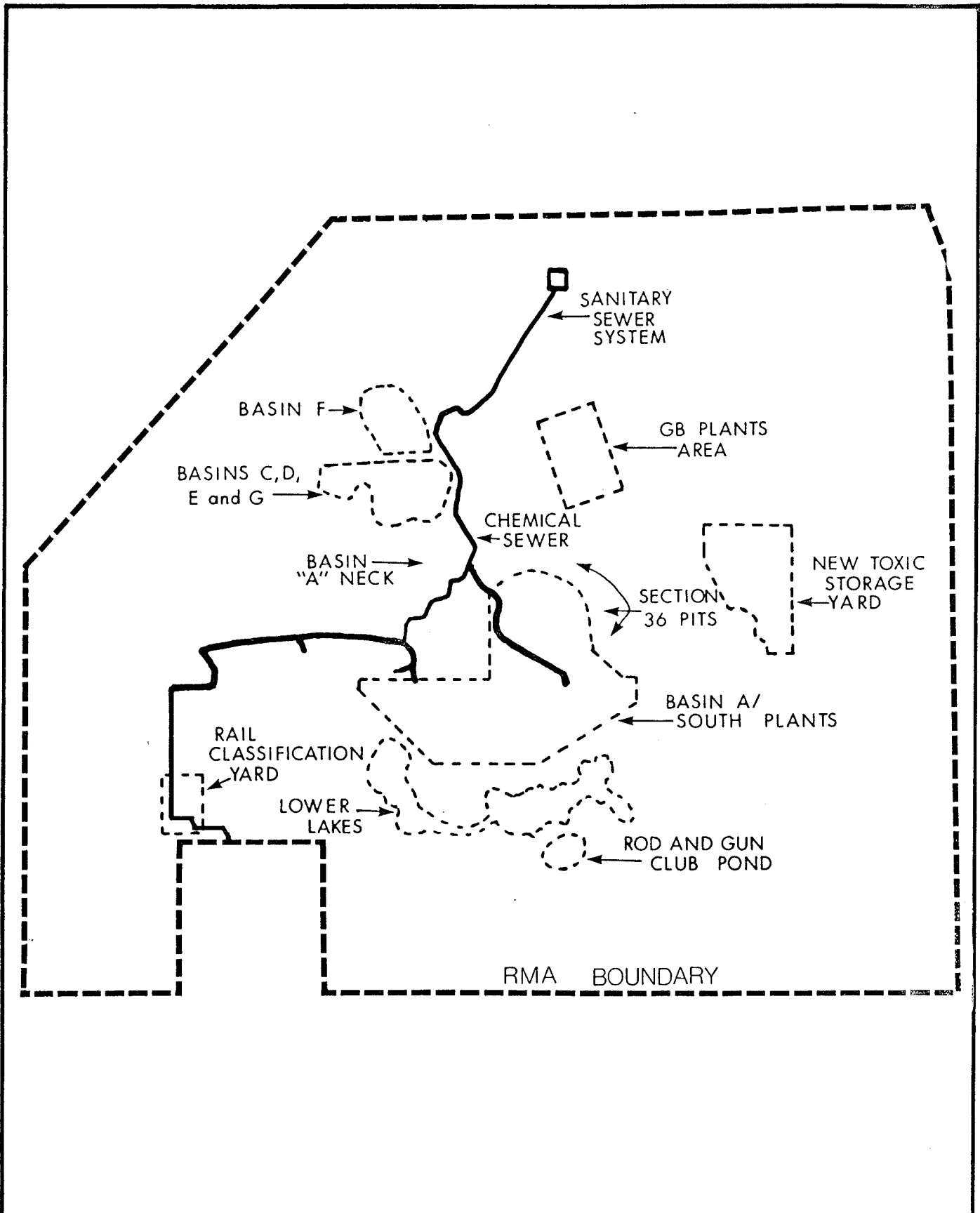

Figure 1.1-2
Sources of Contamination

Source: RMA, 1983

Prepared for:
**U.S. Army Toxic and Hazardous
Materials Agency**
Aberdeen Proving Ground, Maryland

as the lower lakes area, with the exception that mercury has not been detected.

GB Plants - were the site of GB nerve agent production and have the potential for DIMP contamination.

Section 36 Pits - were used to burn, bury, and test various ordnance for the Army. Compounds found include insecticides and their raw materials, and dithiane. Potential exists for mustard, arsenic, mercury, and high salt concentration.

New Toxic Storage Yard - past storage of chemical munitions and materials occurred here. Potential for contamination is small, but phthalates and cyclohexanone have been found.

1.1.3 RESPONSE ACTIONS

A number of contamination control measures have been implemented at RMA, and additional control measures have been planned. Individual components of the overall contamination control strategy as they were documented (RMA, 1983) are discussed briefly in the following paragraphs.

North Boundary: Expanded Containment/Treatment - Ongoing Action

The containment system installed at the north boundary of RMA consists of:

(1) a physical barrier (slurry wall); (2) dewatering wells to intercept the natural flow of ground water exiting along the northern boundary; (3) organic contaminant removal through a ground water treatment facility; and (4) recharge wells to reinject treatment water on the downgradient side of the slurry wall.

Basin F: Enhanced Evaporation and Contaminated Sewer Removal

- Evaporation Ongoing/Contaminated Sewer Removal Complete

The enhanced evaporation system consists of: (1) construction of dikes on the dry surface of the partially evaporated basin, and (2) spreading of the liquid over the entire surface of Basin F to maintain a maximum solar evaporation rate for the Basin. This measure is intended to enhance the

evaporation of liquid in the Basin and minimize surface water inflow. Construction of this system was recently completed. The removal of the contaminated chemical sewer was completed in June 1982.

Irondale: Containment/Treatment - Ongoing Action

The hydrologic control system installed at the southern part of the northwest boundary (referred to as Irondale area) is conceptually different from the physical containment facility installed at the north boundary, although the functional objective of each system is to stop migrating contaminants from exiting RMA boundaries. The control system consists of two rows of dewatering wells, one row of recharge wells beyond the dewatering wells, and a treatment facility. The treated water is pumped through a distribution system to the recharge wells.

Northwest Boundary: Containment/Treatment - Programmed Action

The northwest boundary control system is currently being constructed and is scheduled to be implemented during 1984. When the installation is complete, it will intercept the only known migrating plume of contamination presently uncontrolled at the boundaries. The containment system selected for design at the northwest boundary uses the technologies of a hydrologic barrier/bentonite slurry wall and a ground water treatment facility. The proposed ground water treatment plant is similar to the one installed at the north boundary system. The technologies chosen for the water treatment consists of filtration and carbon adsorption.

Sanitary Sewer: Removal/Upgrade - Planned Action

Three projects are being considered to correct the problems encountered with the sanitary sewer system. The first action includes repair of the South Plants Area sewer lines to include lining and replacement; the second addresses the repair of the North Plants sewer lines; and the third will deal with the removal of the lines that link the North and South Plants Areas and the Administration area. Implementation of this remedial action will eliminate the rapid transport of contaminants presently entering the deteriorated sewers along the line extending from

the South Plants Area, through Basin A, and north to the north boundary treatment facility.

Basin A: Windblown Dust Control - Ongoing Action

RMA has historically experienced periods of high winds and dry conditions which result in dust storms and wind erosion. Hazardous materials within Basin A have been found to be transported away from Section 36 to other locations on RMA. Application of a synthetic polyvinyl acetate dust palliate is being evaluated on approximately 28-ha of Basin A. The sprayed areas will be monitored for effectiveness and additional acreage will be covered, if successful. Reapplication of the surface stabilizer will be required every 5 years to provide a long-term solution to the problem.

Lower Lakes Sediment Removal - Planned Action

Aldrin and dieldrin have been found to be present in the lower lakes sediment in concentrations in excess of levels that permit safe wildlife habitat. Funding has been requested to excavate and dispose of the sediments.

Plugging of Deep Well - Planned Action

The injection well in Section 26 was briefly used in the early 1960's for high pressure injection of contaminated waste. Due to a series of small earthquakes in the area, disposal through this well was discontinued. The Army plans to clear the well casing, run pipe analysis/cement bond logs through the well and plug the well. This method will maintain isolation between aquifers and create a stable hole condition. The well may then be completely abandoned with no possibility of problems arising in the future.

Inactive Secondary Source Monitoring - Planned Action

Inactive disposal sites with a potential to release pollutants to the surrounding environment (secondary sources) must be continually monitored to permit early detection of contaminant release that may pose an imminent and substantial danger to public health or welfare. If contaminant migration is detected, a reassessment must be made by the

Army to determine what additional remedial action is necessary. Current monitoring programs at RMA have been structured for the primary source areas. These programs are being reviewed to assess whether modifications in sampling locations, frequency, or parameters are needed. If changes are required, funding requests will be expeditiously submitted.

Basin F: Onsite Landfill - Proposed Action

The closure scenario for Basin F involves solidification of the liquid and overburden, removal of contaminated soil underlying the liner, disposal of the waste material in a Resource Conservation and Recovery Act (RCRA) designed landfill, and regrading and revegetation of the reconstructed basin area.

Basin A "Neck": Containment/Treatment - Proposed Action

The containment system selected for a Basin A "Neck" control system will consist of a physical barrier with upstream dewatering, water treatment, and downstream recharge wells. The location of the barrier has been chosen to intercept contaminated ground water migrating through the only alluvial exit out of Basin A.

South Plants: Mound Dewatering - Proposed Action

To control further migration of contaminated ground water from the plants areas, a dewatering well array will be placed within the South Plants Area to reduce the anomalous ground water mound. This mound acts as a driving force of ground water away from contaminated zones beneath the manufacturing complex.

South Plants Area: Surface Water Management - Proposed Action

The concept of surface water control is being developed to be compatible with the previous control strategy components for Basin A and the South Plants Area which provide for containment of ground water contaminant migration. Surface water controls in the South Plants Area will divert clean water away from contaminated zones in Basin A and the South Plants Area to acceptable outfall points while at the same time isolating contaminated runoff within the plant complex. A proposed scheme includes construction of surface conduits to collect runoff and retention basins

to hold surface flows that may be contaminated until the water can be sampled.

Rail Classification Yard: Soil Removal - Proposed Action

The source of DBCP being treated by the Irondale system is located in the Rail Classification Yard. This strategy component entails excavation of leachable contaminated soils within the yard and disposal in the on site RCRA landfill used for Basin F wastes. All surface structures will be temporarily removed during excavation operations. Once all contaminated material is removed, clean backfill will be installed. To complete the effort, surface structures will be replaced following any required decontamination. Ground water monitoring will be continued for three years to assure cleanup was complete.

1.1.4 STUDY AREA

Previous investigations on and in the vicinity of RMA have determined that contaminants either were or could potentially move offsite by ground water movement through shallow aquifers, by flooding of surface features at RMA, or by air movement. Ground and surface water movement from RMA is generally to the northwest in the direction of the South Platte River. Natural surface drainages have been modified as a result of land development between RMA and the South Platte River. O'Brian Canal carries water northeast and intercepts surface flow from First and Second Creeks.

The Woodbury Chemical Site and Sand Creek Site, EPA Superfund sites, are located immediately south of Sand Creek and only 3-km west of RMA. Offsite monitoring of contamination from RMA must consider the potential influence of these contamination sources.

Offsite study area boundaries were selected on the basis of the aforementioned consideration and on the presence of unambiguous surface features. In general, the study area is confined to the area between the South Platte River and the west, northwest, and north boundaries of RMA (Figure 1.1-3). The area chosen is considered quite conservative in that it includes areas that, based on hydrologic and hydrogeologic

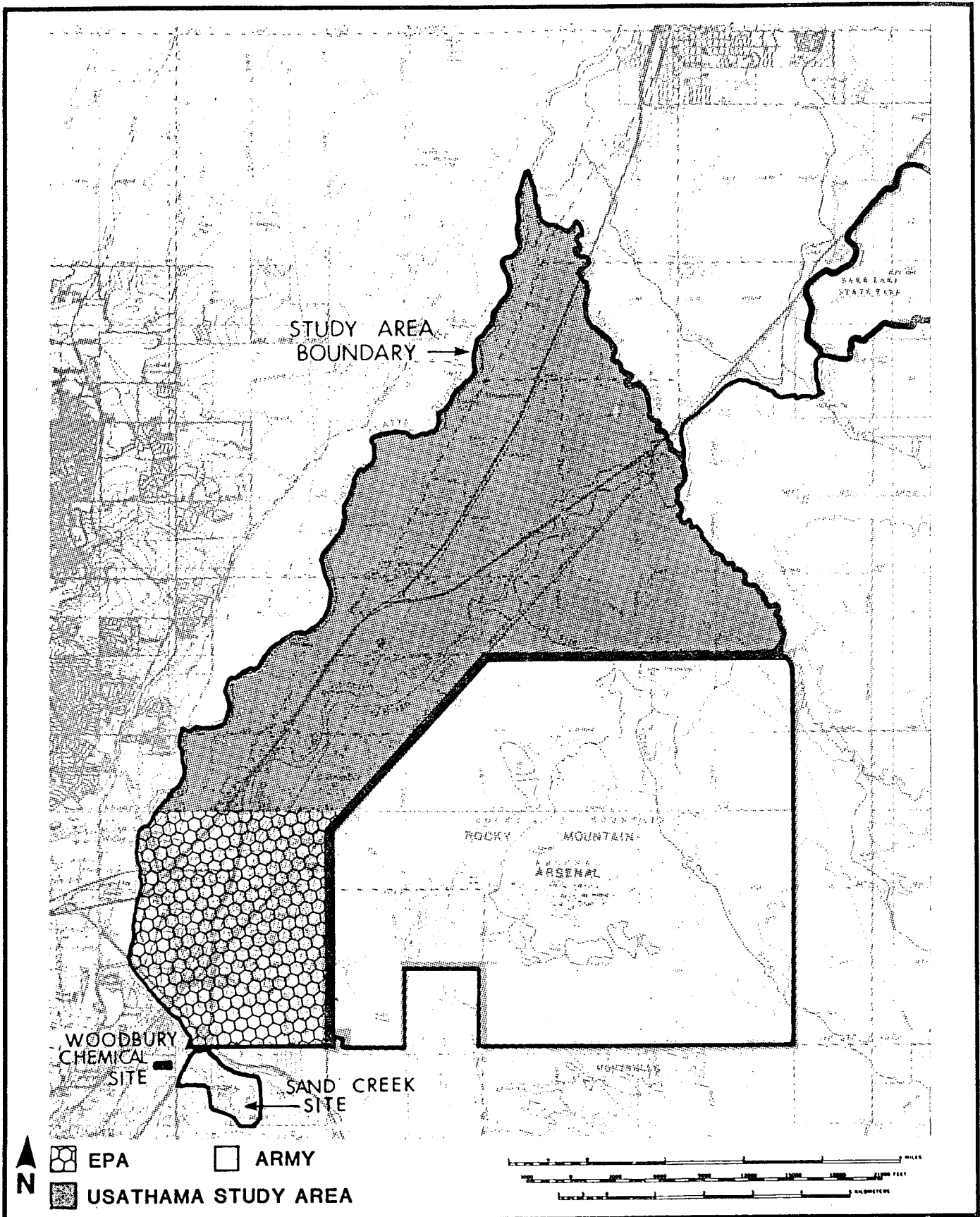

Figure 1.1-3
 Study Area Boundaries

Source: ESE, 1984

Prepared for:
 U.S. Army Toxic and Hazardous
 Materials Agency
 Aberdeen Proving Ground, Maryland

considerations, are not expected to be contaminated by materials originating from RMA.

The study area boundaries are defined as follows:

1. South Boundary - a line extending east to west along East 56th Avenue from the southwest corner of RMA to Sand Creek, then along Sand Creek to its confluence with the South Platte River;
2. West and Northwest Boundary - the South Platte River, and
3. Northeast Boundary - Second Creek from the northeast corner of RMA to its confluence with the South Platte River.

Because of potential contamination of surface waters which are intercepted by the O'Brian Canal, the study area will include an extension of the O'Brian Canal from its junction with Second Creek to Barr Lake.

The study area encompasses residential and industrial areas located to the northwest and north of RMA. The area north of RMA is primarily dryland farming with some rural residential areas and scattered patches of intensive agricultural use.

Ground water located to the west of RMA, has been identified (SACWSD, 1983) as potentially contaminated. The nature and extent of this contamination is currently being investigated by EPA's Field Investigator Team subcontractor. RMA has been referenced as a possible source of contamination in this area; however, the regional ground water flow patterns suggest that ground water contamination occurring southwest of RMA could not have originated on RMA. Additional ground water data are required from this area in order to better define the contamination sources. EPA should remain the lead agency in these investigations as required by the DOD/EPA MOA. Any work undertaken by the Army in this area will be coordinated with both EPA and South Adams County Water and Sanitation District (SACWSD) prior to implementation to avoid duplication of work.

1.1.5 TOPOGRAPHY AND SURFACE WATER HYDROLOGY

The topography of RMA consists of stream-valley lowlands separated by gently rolling uplands. The maximum local topographic relief in the area is about 91-meters (m); the elevation above mean sea level ranges from about 1,615-m at the southern boundary of RMA to about 1,524-m north of RMA.

The overall surface drainage in the region is toward the northeast and all of RMA is drained by the South Platte River and its tributaries. The South Platte River originates in the Rocky Mountains southwest of Denver, and then flows in a general north-northeast direction to the vicinity of Greeley, where it swings toward the east.

RMA contains parts of five different drainage basins as shown in Figure 1.1-4. Proceeding from southwest to northeast, these basins are Sand Creek, Irondale Gulch, Basin A, First Creek, and Second Creek. All these areas are sub-basins in the South Platte River drainage. The South Platte River flows northeasterly at a distance of approximately 4.8-km from the RMA northwest boundary.

Two major irrigation canals, O'Brian Canal, Burlington Ditch, and several smaller ditches run southwest to northeast between RMA and the South Platte River. O'Brian Canal and Burlington Ditch receive drainage from RMA by interception of First and Second Creeks. These flows are either stored in the reservoir at Barr Lake State Park or distributed into one or more of many irrigation ditches downstream, depending on the season and the quantity of water available.

1.1.6 GEOLOGY AND GEOHYDROLOGY

RMA is located in the Denver Basin, a structural depression underlying a 1,735,000-ha area from Greeley in the north, to Colorado Springs in the south, and from the Rocky Mountain Front Range in the west, to near Limon in the east (Figure 1.1-5). This oval-shaped basin is approximately 193-km long by 113-km wide and filled to a depth of 4,572-m with sediment composed of limestone, sandstone, shale, and conglomerate.

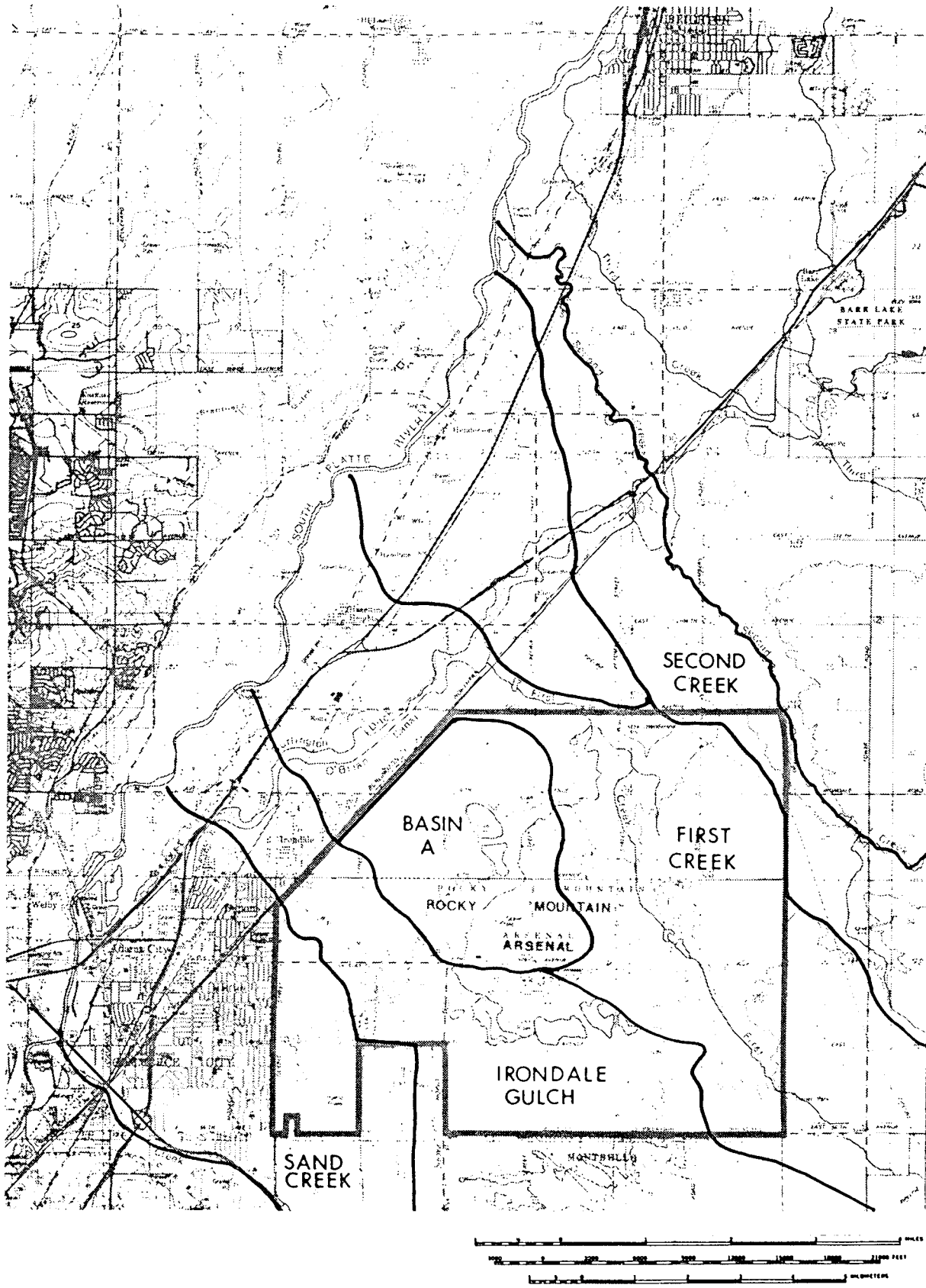
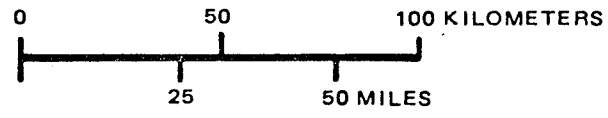
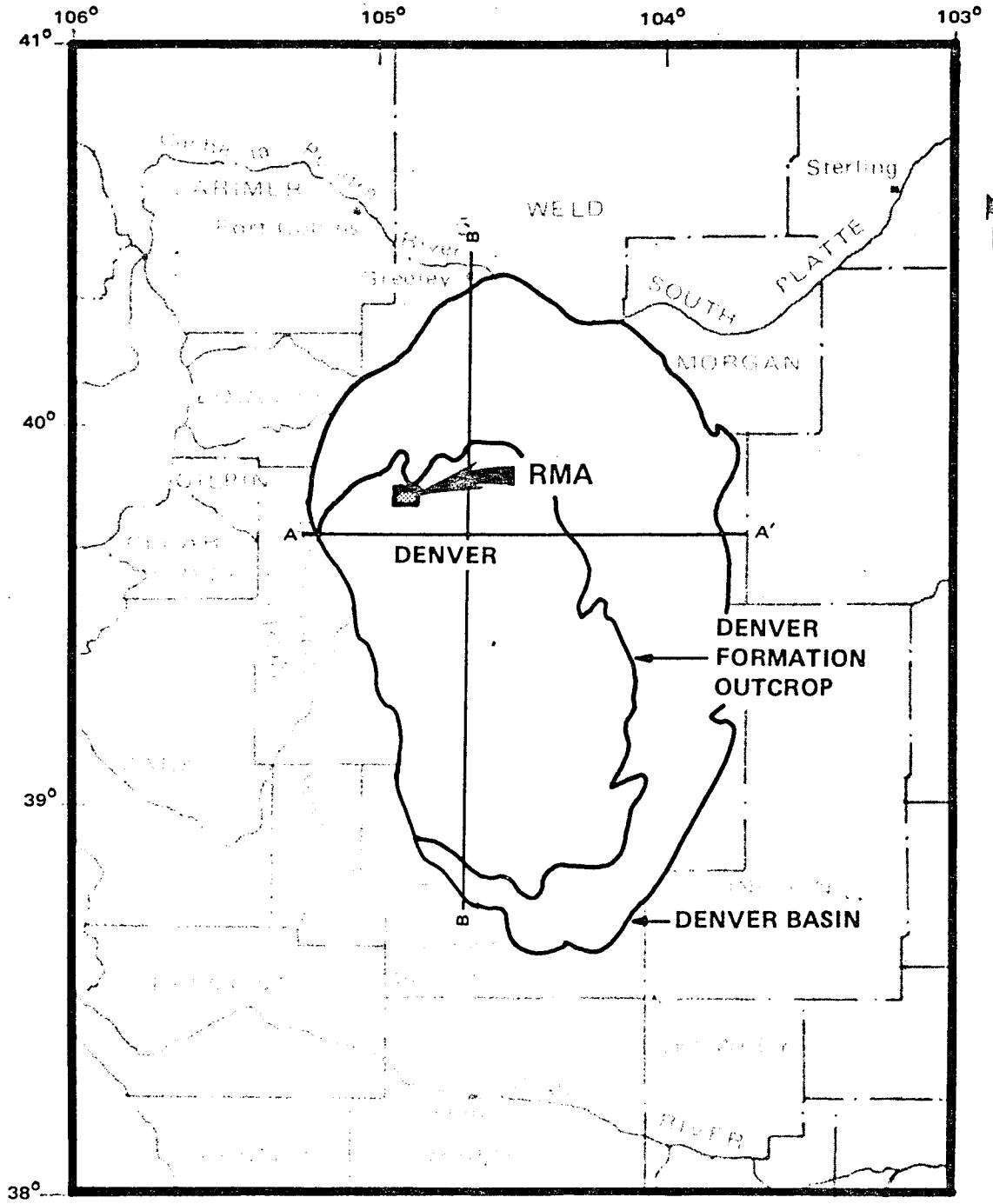

Figure 1.1-4
 Drainage Basins

Source: Resource Consultants, 1981

Prepared for:
**U.S. Army Toxic and Hazardous
 Materials Agency**
 Aberdeen Proving Ground, Maryland



Note: Cross Sections A-A' and B-B' are shown on Figure 1.1-6.
Source: ROBSON, 1981

Figure 1.1-5
Geologic Setting of Rocky Mountain Arsenal

Prepared for:
U.S. Army Toxic and Hazardous Materials Agency
Aberdeen Proving Ground, Maryland

Generalized upper stratigraphic sections of the Denver Basin are shown in Figure 1.1-6. Ground water is obtained from unconsolidated alluvial deposits in the South Platte River Valley and from several bedrock aquifers. The four major deep aquifers in the Denver Basin are located in the Fox Hills Sandstone, the Laramie and Arapahoe formations of Late Cretaceous and Early Tertiary age, and the Dawson Arkose of Tertiary age.

The artesian, or in some cases semi-artesian conditions, observed in the Denver aquifer at RMA result from the fact that a large area of outcropping Denver formation material occurs at an elevation over 1,981-m above sea level near Colorado Springs. The outcropping Denver formation at RMA (overlain by alluvium in many areas) is at a lower elevation. The ground water in the Denver formation to the south, because of its higher elevation, has the pressure needed to drive water through the Denver formation underneath RMA. Although the Denver formation has many local areas of low permeability, considerable lateral ground water movement occurs on a regional scale. From the regional viewpoint ground water moves slowly underneath RMA through the Denver formation toward the South Platte River.

Locally heavy pumping from the Denver formation, or mounding of water in alluvium, has modified or masked the historic artesian pressure. However, in many areas of RMA the water table mirrors closely the potentiometric heads in the shallow Denver. Flow rates of ground water vary greatly throughout RMA. Where the water table is in saturated alluvial channels, the flow is usually several orders of magnitude greater than in the Denver formation.

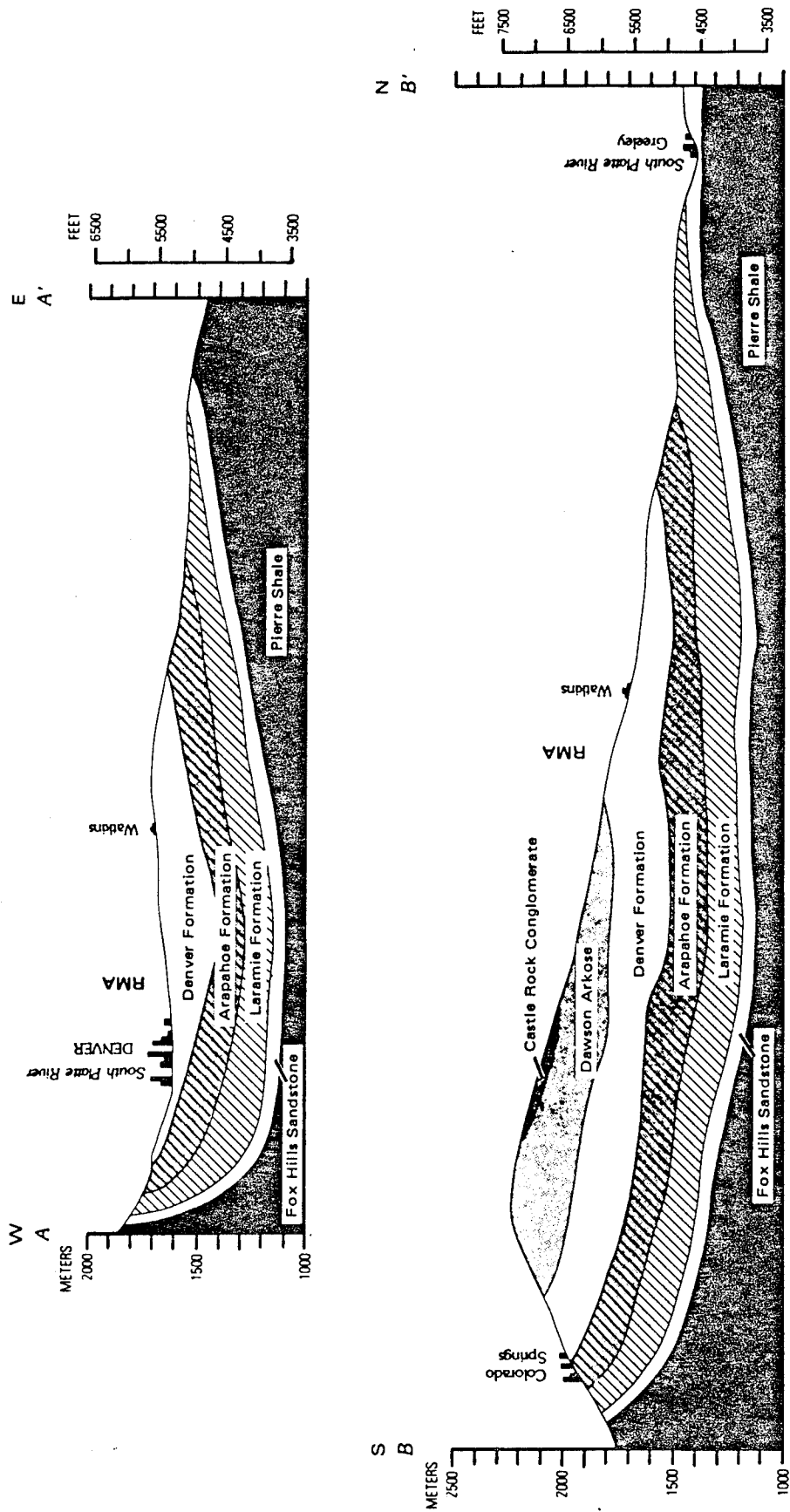

Offpost areas with the highest potential to be contaminated by RMA ground water are indicated in Figure 1.1-7. These areas were estimated using onpost water quality data and the 1982 ground water contour map and have not been verified with actual data in the potentially contaminated plume areas.

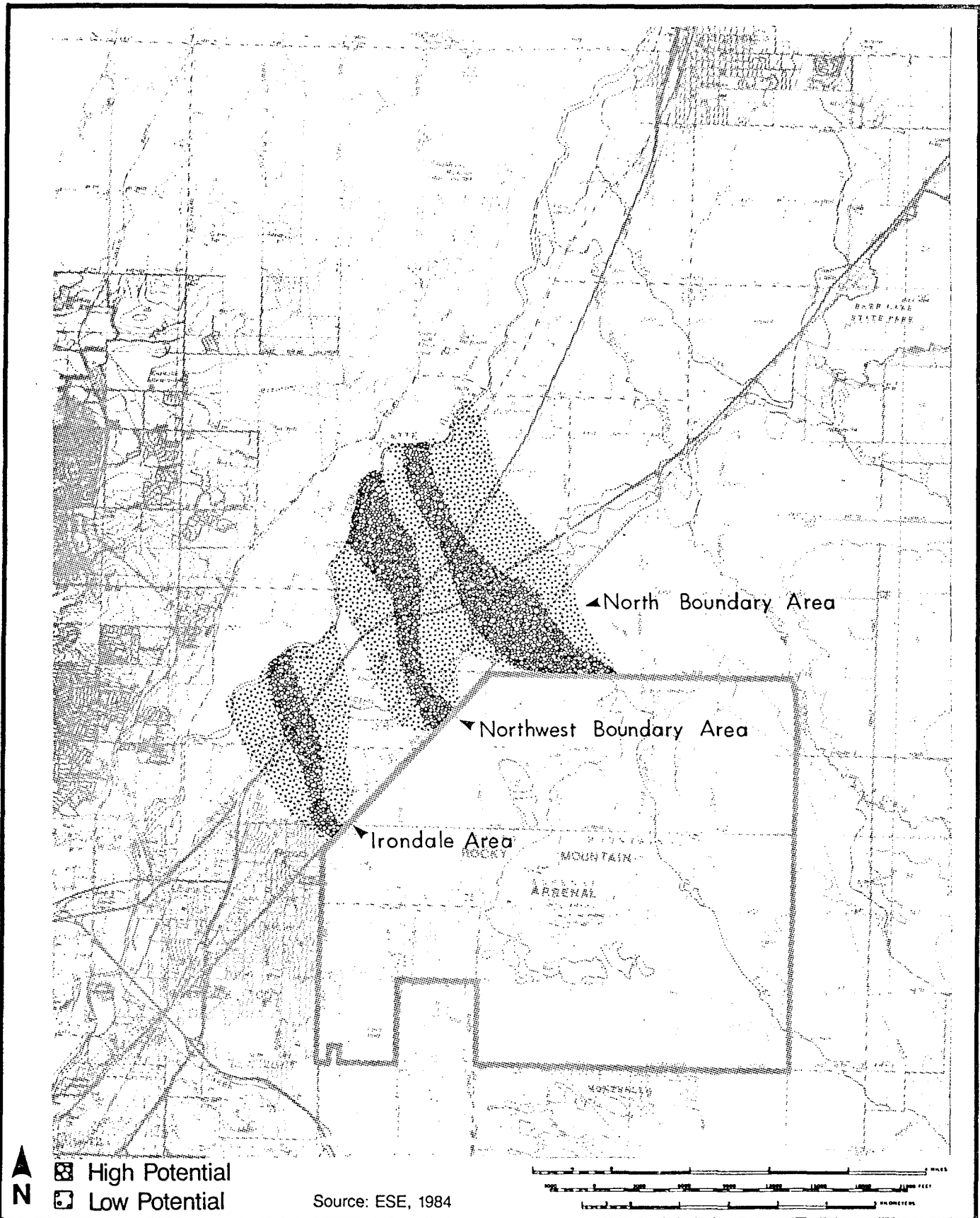

Prepared for:
**U.S. Army Toxic and Hazardous
 Materials Agency**
 Aberdeen Proving Ground, Maryland

Figure 1.1-6
Upper Stratigraphic Sections of Denver Basin
Note: Locations of Cross Sections are shown on Figure 2.2-1
 Source: ROBSON, 1981



 N
 High Potential
 Low Potential

Source: ESE, 1984

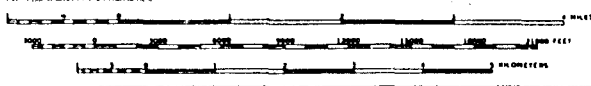

Figure 1.1-7
 Potentially Contaminated
 Offpost Areas

Prepared for:
 U.S. Army Toxic and Hazardous
 Materials Agency
 Aberdeen Proving Ground, Maryland

Generally, the soils at RMA and the study site are well-drained, loamy upland soils. A low percentage of the soils, primarily along river beds, are represented by saturated, poorly-drained silt loams.

1.1.7 WATER QUALITY

Surface Water Quality

Surface water in the study area has been analyzed for many of the RMA migrating contaminants (Table 1.1-1) on numerous occasions since approximately 1976. This sampling and analysis has been performed as part of several different monitoring efforts, including various segments of the 360° Monitoring Program.

The data derived from surface water monitoring programs to date have not been compiled or analyzed to the degree required for identification of long term trends. The dominant contaminant in ground water reaching the north and northwest boundaries is DIMP. This constituent has been included in all the surface water monitoring to date. Using DIMP as an indicator, it appears that First Creek was being contaminated by ground water inflows when monitoring began. Contamination enters the surface flows as the stream crosses the discharging ground water plume between the RMA boundary and the O'Brian Canal. The South Platte River watershed in the study area contains numerous potential contamination sources. The Woodbury Chemical and Sand Creek "Superfund" sites are on Sand Creek, just above the South Platte River confluence, causing potential masking of data and limiting the conclusions that can be drawn concerning sources of contamination in the western portion of the study area.

Ground Water Quality

Ground water concentrations of RMA migration contaminants exceeding criteria have been observed only within about 2-km of the RMA boundary. Although there are little data characterizing deeper aquifers, the available data indicate that to the north and northwest of RMA, the alluvial aquifer is the only significantly contaminated aquifer. Available data, by and large, are consistent with inferences which can be drawn based on a knowledge of onpost contamination distribution, history of activities onpost, ground water flow patterns, and the chemical

Table 1.1-1. Chemical Analysis Methods (Page 1 of 3)

Analyte(s)	Matrix	Available Analytical Methods	Technique	Approximate Method Detection Limits†††
Aldrin, Endrin, Dieldrin, Isodrin	Water	EPA Method 617	GC/EC	0.010 µg/l
		EPA Method 608	GC/EC	0.010 µg/l
	Sediment	RMA Method 1*	GC/EC	0.20 µg/l
		EPA Region V-CRL (198-207)	GC/EC	1-3 µg/g
Dibromochloropropane (DBCP)	Water	EPA Method 608.1	GC/EC	0.04 µg/l
		RMA Method 2*	GC/EC	0.2 µg/l
		CDH Method 1**	GC/EC	0.2 µg/l
Dicyclopentadiene (DCPD)	Sediment	***	---	---
		RMA Modified Method 624*	GC/MS	---
		EPA Method 624	GC/MS	---
		CDH Method 2**	GC/FID	20 µg/l
Diisopropylmethylphosphonate (DIMP)	Sediment	***	---	---
		EPA Method 625	GC/MS	---
		RMA Method 3*	GC/FPD	4.6 µg/l
		CDH Method 3**	GC/FPD	0.5 µg/l
Dimethylmethylphosphonate (DMMP)	Sediment	***	---	---
		RMA Method 3*	GC/FPD	---
		EPA Method 625	GC/MS	---

Table 1.1-1. Chemical Analysis Methods (Continued, Page 2 of 3)

Analyte(s)	Matrix	Available Analytical Methods	Technique	Approximate Method Detection Limits†††
p-Chlorophenylmethylsulfone (PCPMSO ₂)	Water	RMA Method 4*	GC/FPD	20 µ/l (all)
p-Chlorophenylmethylsulfoxide (PCPMSO)		EPA Method 625	GC/MS	---
p-Chlorophenylmethylsulfide (PCPMS)	Sediment	***	---	---
1,4-Dithiane, 1,4-Oxathiane	Water Sediment	RMA Method 4* ***	GC/FPD ---	20 µg/l (all) ---
Benzene	Water	EPA Method 602, 624	GC/PID, GC/MS	0.2 µg/l, 4.4 µg/l 0.2 µg/l, 6.0 µg/l
Toluene				---
Xylene				---
Chlorobenzene	Sediment	EPA SW-846 Manual†† Method 8240	GC/MS	0.2 µg/l, 6.0 µg/l 1 µg/g (all)
Chloroform	Water	EPA Method 601, EPA Method 624	GC/HALL, GC/MS	0.05 µg/l, 1.6 µg/l 0.12 µg/l, 2.8 µg/l 0.10 µg/l, 2.8 µg/l 0.12 µg/l, 1.9 µg/l 0.03 µg/l, 4.1 µg/l 0.25 µg/l, 6.0 µg/l
Carbon Tetrachloride				
Dichloroethylene				
Trichloroethylene				
Tetrachloroethylene				
Chlorobenzene	Sediment	EPA SW-846 Manual†† Method 8240	GC/MS	---

Table 1.1-1. Chemical Analysis Methods (Continued, Page 3 of 3)

Analyte(s)	Matrix	Available Analytical Methods	Technique	Approximate Method Detection Limits†††
Chloride Fluoride	Water	EPA Methods 325.3, 340.2	Titration Electrode	5 µg/l 0.1 µg/l
	Sediment	EPA Region IV Methods† CRL-380, 378; Modified EPA Water Proc.	--- --- ---	--- --- ---

* Rocky Mountain Arsenal Analytical Methods (see Appendix C).

† Chemistry Laboratory Manual for Bottom Sediments and Elutriate Testing
U.S. EPA, Region V, EPA-905/4-79-014, March 1979.

** Colorado Department of Health Analytical Methods (See Appendix C).

†† Test Methods for Evaluating Solid Waste, U.S. EPA Office of Solid Waste,
SW-846, July 1982.

*** Specific analytical methods not located. Suitable extraction and analysis
procedures may be developed or are available in above references.

††† Indicated detection limits are those provided in the referenced available analytical method.

11/09/84

properties of the contaminants related to mobility and persistence in ground water.

The Irondale Plume is characterized by DBCP; DIMP and DCPD are not found. The Irondale Plume is limited in lateral extent perpendicular to the ground water flow direction, but it may extend more than 1.13-km from the RMA boundary, the farthest downgradient sampling point.

The Northwest Boundary Plume offpost is not well characterized by available data. Fluoride and chloride are the only analytes which exceeded standards in samples taken from the Northwest Boundary Plume. Available data do not characterize the area within 0.97-km of the RMA boundary, and this area may be contaminated by aldrin and DBCP.

The North Boundary Plume is the most complex in terms of the number of potentially toxic contaminants, their distribution, and trend, especially in the context of the effectiveness of the north boundary containment. The North Boundary Plume area is also the most intensively monitored. The spatial and temporal patterns of the sulfur compounds as well as DBCP, DCPD, and DIMP are complex.

DCPD concentrations in the near north boundary area (within 1.1-km) are above applicable criteria. DCPD concentrations have fallen steadily since 1975 at the only well in this area with sufficient sampling intensity and duration to detect trends. Although DCPD levels are high in the near north boundary area, DCPD is consistently and distinctly absent at all locations more than 2-km from the boundary. Chloride, fluoride, and DIMP contamination extends much farther away from the RMA boundary, consistent with their expected mobility and persistence. Since chloride and fluoride concentrations in the contaminated plume are not much above background levels, DIMP is the clearest indicator of the extent of RMA contamination. DIMP extends north to the South Platte River as far as 8-km, although it is well below applicable criteria beyond 2-km from the RMA boundary.

1.1.8 METEOROLOGY AND AIR QUALITY

The RMA area is generally classified as mid-latitude semi-arid. This indicates an area with hot summers, cold winters, and relatively light in fall. Mean maximum temperatures range from 6 degrees Centigrade (°C) in January to 31°C in July. The mean minimum temperatures are -9°C in January and 15°C in July. Precipitation in the general region is approximately 30-to 40-cm per year with approximately 80 percent falling between April 1 and September 30. Snow and sleet usually occur from September to May with the heaviest snowfall in March and possible trace accumulations as late as June. Thunderstorms occur frequently in the region. They are generally accompanied by heavy showers, severe gusty winds, frequent thunder and lightning with occasional hail. There are approximately 93.1 days per year with a cloud cover of 30 percent or less. Early morning inversions over the Denver Metropolitan Area are common, but they rarely persist through the day. Inversions occur when cooler air is trapped near the earth's surface by warmer air above. This prevents mixing and causes accumulation of pollutants.

The prevailing winds at RMA are from the south and south-southwest, paralleling the foothills west of Denver. Occasional winds are also out of the north-northwest, north, and east. Wind speeds average about 14-kilometers per hour (km/h) annually. The windy months are March and April, with gusts as high as 105-km/h. These months come immediately after the driest months of the year (November through February). Therefore, March and April have high potential for dust storms.

The Denver Metropolitan Area has experienced chronic air quality problems in recent years. During stagnant and/or inversion conditions, ozone and carbon monoxide concentrations sometimes create extremely poor air quality. This problem has generally been associated with motor vehicles, and the area impacted includes the study area.

RMA's potential influence on air quality includes wind-borne migration of contamination-bearing particulates from dry waste basins and volatile organic emissions from Basin F. Because of these concerns, the U.S. Army Environmental Hygiene Agency (USAEHA) was requested to examine potential

air quality problems and recommend appropriate precautions. A suspended particulate study of the dry basins was conducted in 1981 by USAEHA to evaluate the health hazard posed by low level contamination effects of fugitive dust (USAEHA, 1981). The contaminants studied are arsenic, mercury, cadmium, copper, lead, aldrin, dieldrin, and endrin.

Concentrations of the various contaminants monitored in the fugitive dust were considered not to pose a significant hazard to members of the general population around RMA or to individuals occupationally exposed to wind-blown dust emanating from disposal basins at RMA. An additional study to determine the impact of volatile organic emissions from Basin F was completed (USAEHA, 1981). The study concluded that operation of the enhanced evaporation system at Basin F will not affect the overall lifetime cancer risk to the general population.

1.1.9 BIOTA

Most of the land within the study area has undergone considerable disturbance as a result of human occupation and development. The municipality of Commerce City is located immediately west of RMA and is currently in industrial, commercial, and residential use. North of RMA most of the land is developed for dryland agriculture. Livestock grazing, dryland crops, feedlots, and rural residential uses predominate. The area northeast of Commerce City is a major transportation corridor. Although natural areas are small and most are highly disturbed, the area offers suitable habitat for a variety of wildlife species.

1.2 GENERAL APPROACH

The general approach to the contamination assessment (Phase I) is to develop data adequate to determine:

1. Ground water quality in potentially affected population centers;
2. Delineation of expected ground water plumes; and
3. Characterization of background water quality.

Based on a review of available data a geotechnical program has been developed that incorporates existing information into the rationale for the contamination assessment program.

Phase I will result in the development of a report summarizing and evaluating information on offsite movement of contaminants and identifying the types, concentrations, and locations of these contaminants in offsite areas. Information on PPLVs obtained during Phase I will be used to determine the potential hazard posed by RMA contaminants offsite. The combination of information from these sources will permit the identification of important contaminants, delineate important pathways of movement offsite, define those compounds which pose potential health risks, and determine the offsite areas of potential concern. Evaluation of these data may lead to the design and implementation of additional studies during Phase II.

Phase II studies would obtain additional information on selected pathways and risk factors for selected contaminants sufficient for the development of appropriate mitigation procedures. Phase II, if implemented, would result in the development of a comprehensive remedial action plan which addresses all pathways of movement of contaminants off RMA which have an impact on the human population offsite.

The contamination assessment program consists of two discrete evaluations. Samples from representative potable water supplies will be taken and analyzed. The analyses will then be evaluated in reference to drinking water standards, water quality criteria or USAMBRDL health criteria to produce a preliminary exposure assessment.

In addition to the exposure assessment, a monitor well installation program may be conducted to provide data for contaminant plume delineation, for identification of exposed populations, as input to the remedial action determination, and to assist in determining the effectiveness of the boundary control systems. The well installation program will consist of completion of 30 monitor wells, collection of surface water flow data, collection of ground water and surface water chemistry samples, and soil sampling and aquifer testing.

Based on the results of the potable water sample analyses and installation and testing of 30 monitor wells, a contamination assessment

will be made to define those areas of concern with regard to offsite contamination and to identify any additional data that will be required to address tasks of this contamination assessment study.

1.3 ORGANIZATION OF THE TECHNICAL AND MANAGEMENT PLANS

Section 2.0 describes the sampling of active consumptive use wells in the study area. Well selection criteria and sampling methodology are discussed. Section 3.0 of this plan describes the specific geotechnical program required to meet the objectives of the Contamination Assessment (Phase I). This section contains detailed procedural guidelines for well installation, development and testing, soil sampling, geophysical logging and surveying of well sites. Section 4.0 describes the sampling procedure for surface water, ground water and Section 5.0 describes sampling procedures for surface water and sediment sampling.

The chemical analysis procedures and method certification are addressed briefly in Sections 6.0 and 7.0, respectively.

Section 8.0 describes the biota guidelines for direct data gathering activities such as mark and recapture/resight techniques of cottaintail rabbits and measuring the rate of uptake of contaminants by waterfowl.

Section 9.0 describes the contaminant assessment methodology which will be required to determine site specific contamination and migration and to determine the effectiveness of the boundary control systems, and to provide possible recommendation for further survey.

Section 10.0 outlines the reports deliverables under this contract, the procedures used for document production and the anticipated scheduling of the reports.

Management support for the conduct of the technical activities described in Sections 2.0 through 10.0 of this plan is contained in the Management Plan. The Management Plan describes the following: Project Organization and Management Procedures (Section 2.0); Data Management Plan (Section 3.0);

Safety Plan (Section 4.0); and Reporting and Administration Requirements. These management elements describe the specific details and procedures to control the conduct of technical activities and ensure accurate, timely transmission of data and reports required in the survey and provide the operational procedures required to ensure that all activities are conducted in a safe manner.

2.0 CONSUMPTIVE USE WATER WELL SAMPLING

Ground water sampling for the offpost contamination assessment program consists of sampling a representative number of active consumptive use water wells within the study area and two quarterly sampling periods of monitor wells as discussed in Section 3.0. Results of the consumptive use and first quarter samples will be discussed in the Quarterly Data Reports in order to identify any immediate human health risks. Sequential sampling periods and anticipated dates of task initiation are presented in Figure 2.5-1 of the Management Plan.

2.1 SAMPLING NETWORK

The distribution of the consumptive use water well sampling network has been designed to provide initial data on areas considered to have a high potential for significant amounts of the RMA migrating contaminants. Sampling points were selected randomly from available points within specified areas. These areas and their importance to the contamination assessment are described below.

2.1.1 CONSUMPTIVE USE WATER WELL SAMPLING

Consumptive use water well sampling is being conducted to determine the nature and extent of such contamination. These data will assist in the identification of overall water flow, water quality and possible human health risks. The Army, State and county health officials have an ongoing quarterly sampling program involving 43 wells. These 43 wells were identified in previous studies as the 360° Program wells and the Army-deep (Shell) wells. For general discussion of the consumptive use sampling program, these 43 wells will be referenced as the 360° Program wells. In order to provide a large data base in which to determine health risks under this task, an additional 82 wells used for consumptive use wells and located within the study area will be sampled. These 82 wells will be separated between wells completed into unconsolidated materials (shallow wells) and those completed into bedrock (bedrock wells). Seventy-six shallow wells and 6 bedrock wells will be sampled. This will increase the ongoing sampling program to 125 wells.

360° Program

The 360° Program dates back to 1975. In May of 1975, two water sampling plans were initiated at RMA. One plan was in response to a series of lawsuits against RMA and Shell by residents north of the Arsenal complaining of contaminated domestic water supplies. The other plan was in response to a Cease and Desist Order issued by the State of Colorado ordering that RMA and Shell stop contaminating the State waters of Colorado. Two months later, these two plans were consolidated into one, resulting in the establishment of 42 sampling sites on and off the Arsenal.

The design and implementation of this sampling scheme was carried out in coordination with the Project Manager Chemical Demilitarization Installation Restoration (PM-CDIR) and with the cooperation of Shell and CDH. It was intended that these 42 sites would be sampled on a monthly basis for the 15 parameters shown in Table 2.1-1. In October 1975, the CDH detected the presence of organic solvents and phthalate esters in isolated RMA well water samples.

The discovery of these organic compounds in well samples led to a major shift in the water quality monitoring program. It was felt that because these newly detected compounds are associated with materials available to the public, these contaminants detected in ground water from RMA could come from sources off the Arsenal. The initial sampling program was restricted to the central and north part of RMA, as well as offpost to the north. In order for RMA to unequivocally declare what has been contributed to ground water contamination the antecedent water quality flowing on to the Arsenal had to be determined. A program was developed to monitor water well and surface water sites including the RMA and offpost sites to the north and west of RMA perimeter.

Phase I of the program, initiated in January 1976, included 124 sampling sites (surface and subsurface) on RMA and 24 offpost sites selected by the Tri-County District Health Department (TCDHD). Water samples from onpost wells were collected monthly and analyses were performed by CDH and Shell, as well as RMA. The offpost samples were collected quarterly

Table 2.1-1. Original 360° Program Analytical Schedule

Analyte	Reported Lower Level or Range of Values	Units
DIMP	10	µg/l
DCPD	30	µg/l
DBCP	0.2	µg/l
Calcium	0.2	mg/l
Chloride	20	mg/l
Fluoride	0.2	mg/l
Hardness (Total)	20	mg/l
Alkalinity (Total)	10	mg/l
Potassium	2.0	mg/l
Magnesium	0.5	mg/l
Sodium	20	mg/l
Nitrate (Total)	0.5	mg/l
Sulfate	50	mg/l
pH	0-14	units
Specific Conductance	0-10 ⁵	mho

11/09/84

and analyzed by all three parties for the same parameters as onpost sites.

Phase II began in November 1976, after review indicated that sampling methods used required better quality control (QC). For many of the previous wells in use, the bore logs were incomplete and in some cases not maintained. In other instances, sampling wells were so close to each other as to be redundant.

This new program (Phase II) set up 55 well sites and 12 surface sites on the Arsenal to be sampled on a quarterly basis. The offpost sites remained the same, using 22 wells and 10 surface sites. The RMA Geohydrology Division was responsible for collecting and analyzing the onpost samples. TCDHD took responsibility for offpost site sampling.

Since the closing of Shell's facilities at RMA, the Army and CDH, along with TCDHD have assumed responsibility for carrying out the tasks of sampling and analysis. The Army has been responsible for program management, data management, program review and data evaluation.

Wells currently included in the 360° Program are listed in Table 2.1-2 and shown in Figure 2.1-1. Wells currently identified as Army-deep monitor wells (considered to be a part of the 360° Program) are listed in Table 2.1-3 and shown on Figure 2.1-1.

Shallow Wells

As indicated above, an additional 76 shallow wells will be included in a one-time sampling of consumptive use wells. Potential candidate wells to be included in the sampling were identified by a review of a Master Extract Register (MER) obtained from the Colorado Division of Water Resources (CDWR), Ground Water Section. The MER lists are permitted wells in a specified area. From the MER, wells that were permitted for consumptive purposes were identified. Photocopy documentation of potential candidate wells were obtained. A substantial variation in the quality of data was noticed among permits. In order to insure and maintain the integrity of the study and circumvent information disparity,

Table 2.1-2. 360° Program Wells.

Identification Number	Owner Address	Location	Comments
IV	Gerald Sitsman 13990 E. 136th St.	T1S, R66W, S30	
VI	Victor Amdahl 16291 E. 136th St.	T1S, R66W, S20	
VIII	Loren E. Snyder 12240 Peoria	T1S, R67W, S36	
XII	Jack Salthouse 12201 E. 120th	T1S, R67W, S1	
XIX	Marie Anderson 10371 E. 123rd Ave.	T1S, R67W, S34	
XX	Joseph R. Himes 11721 Brighton	T2S, R67W, S3	
XXI	G. P. Murray 11010 Havana	T2S, R67W, S11	
XXIV	Robert V. Redding 12600 N. Sable	T1S, R66W, S31	
XXVIII	Denver Products Terminal 8581 E. 96th	T2S, R67W, S16	
XXXII	Sam Dean 8610 Verbena	T2S, R67W, S28	
LIII-B	George Hall 9610 Peoria	T2S, R67W, S13	
LIV	George Hall 9610 Peoria	T2S, R67W, S13	
LV	Jessie Powers 9339 E. 96th	T2S, R67W, S15	

Table 2.1-2. 360° Program Wells (Continued).

Identification Number	Owner Address	Location	Comments
LVII	DM & H Cattle 10700 Peoria #1	T2S, R67W, S12	
LVIII	Mr. Wagoner 11810 E. 136th	T1S, R66W, S26	
LVIX	Mr. Donate 12930 E. 104th	T2S, R67W, S12	
LXIII	Mr. Kallsen 11850 Chambers	T2S, R66W, S5	
LXIV	Mr. Murata 14151 Potomac	T1S, R67W, S4	
C	Owner Unknown 84th & Quebec	T2S, R67W, S28	
CI	Owner Unknown 7711 E. 81st Ave	T2S, R67W, S28	
CII	Owner Unknown 7425 E. 86th Ave.	T2S, R67W, S28	
CIII	Owner Unknown 8340 Pontiac	T2S, R67W, S29	
CIV	Owner Unknown 8356 Syracuse	T2S, R67W, S28	
BOLLERS	Owner Unknown 105th & Hwy 2	T2S, R67W, S12	
OP 304	Army 37304	T2S, R67W, S14	
OP 305	Army 37305	T2S, R67W, S14	
OP 306	Army 37306	T2S, R67W, S14/23 Boundary	

Table 2.1-2. 360° Program Wells (Continued).

Identification Number	Owner Address	Location	Comments
OP 307	Army 37307	T2S, R67W, S14/23 Boundary	
OP 308	Army 37308	T2S, R67W, S13	
OP 309	Army 37309	T2S, R67W, S14/13 Boundary	
OP 310	Army 37310	T2S, R67W, S14/13 Boundary	
OP 311	Army 37311	T2S, R67W, S13	
OP 312	Army 37312	T2S, R67W, S13/34	
OP 313	Army 31313	T2S, R67W, S14	
OP 58	Army 37058	T2S, R67W, S14	

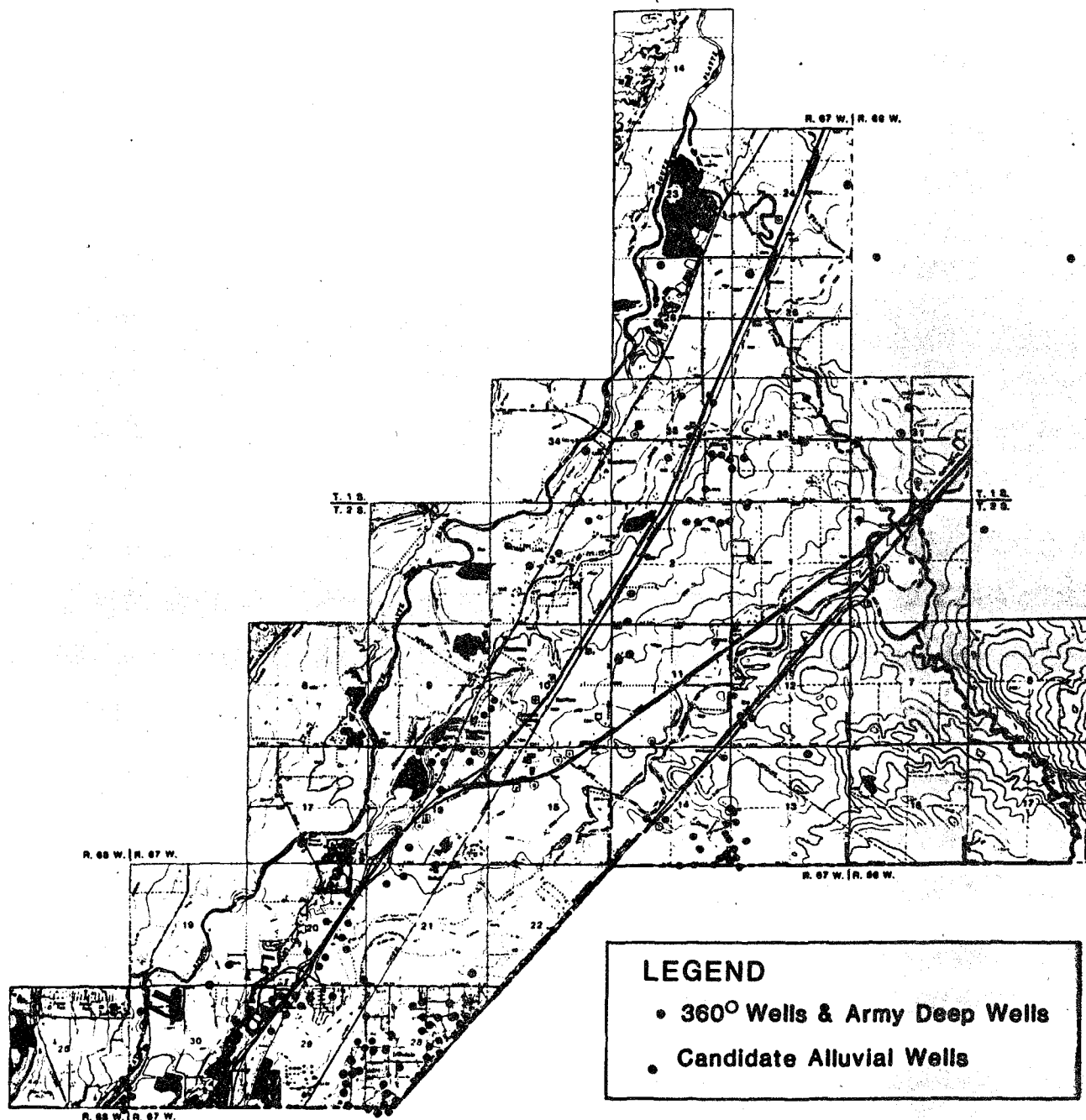

LEGEND

- 360° Wells & Army Deep Wells
- Candidate Alluvial Wells

N

0 1/2 1 2 MILES

SCALE

SOURCE: ESE, 1984.

Figure 2.1-1
Potential Consumptive
Use Sample Locations

Prepared for:
U.S. Army Toxic and Hazardous
Materials Agency
Aberdeen Proving Ground, Maryland

Table 2.1-3. Army Deep Wells

Identification Number	Owner Address	Location	Comments
9755	Army 9755 Peoria	T2S, R67W, S14	No Data Available
9760	Army 9760 Peoria	T2S, R67W, S13	No Data Available
9925	Army 9925 Peoria	T2S, R67W, S14	No Data Available
9955	Army 9955 Peoria	T2S, R67W, S14	No Data Available
10021	Army 10021 Peoria	T2S, R67W, S14	No Data Available
10390	Silver Saddle 10390 Hwy 2	T2S, R67W, S14	No Data Available
11515	Army 11515 E. 96th	T2S, R67W, S14	No Data Available
11921	Army 11921 E. 96th	T2S, R67W, S14	No Data Available

wells were rated according to reliability and completeness of permit data. Emphasis was placed on (1) permit data that would enable hydrologic evaluation and (2) suitability of the well for study purposes. The rating criteria emphasized included location, geology, well completion, pump data, and available quality data. Potential candidate wells are listed in Table 2.1-4 and shown in Figure 2.1-1.

A consumptive use sampling network was designated to prioritize parcels within the study area so that the maximum amount of data would be collected with the specified 76 shallow additional samples. Prioritization of wells was accomplished by assigning random numbers to every candidate well and ranking each well according to random numbers with each parcel. In order to prioritize parcels, the network was constructed taking into account certain geographic areas of elevated concern. Areas of elevated concern include the following types:

1. High population density areas;
2. Pathways of postulated contamination (Irondale Plume, First Creek and Second Creek);
3. Areas proximal to the RMA property boundary (within 1,830-m of the RMA boundary).

Each type of area of elevated concern was plotted on a map of the study area, resulting in a graphical representation of equal hazard areas. The procedure identified four hazard areas:

1. Areas of three elevated concern types (2 parcels);
2. Areas of two elevated concern types (8 parcels);
3. Areas of one elevated concern type (9 parcels);
4. Areas of no elevated concern type (3 parcels);

Each area of elevated concern has been identified alphabetically, and these individual areas have been designated as parcels within the study area. The areas of elevated concern overlap, and these areas and parcel identifications are presented in Figure 2.1-2.

Table 2.1-4. Well Sampling Priority by Parcel. (Page 1 of 5)

Well Number	Random Number	Priority
PARCEL A		
No Alluvial Candidate Wells		
PARCEL B		
2-67-28-50	001	1
2-67-29-32	007	2
2-67-29-25	009	3
2-67-29-29	010	4
2-67-28-46	011	5
2-67-28-45	012	6
2-67-28-22	019	7
2-67-28-11	020	8
2-67-28-47	032	9
2-67-28-13	033	10
2-67-28-27	035	11
2-67-28-49	038	12
*2-67-29-6	040	13
2-67-28-48	041	14
2-67-28-20	044	15
2-67-29-35	046	16
2-67-28-26	048	17
2-67-29-14	049	18
2-67-28-14	057	19
2-67-29-8	054	20
2-67-29-9	068	21
2-67-28-43	075	22
2-67-29-24	084	23
2-67-29-15	086	24
2-67-28-56	089	25
2-67-29-27	090	26
2-67-29-26	095	27
2-67-28-7	096	28
2-67-29-16	100	29
2-67-29-20	101	30
2-67-28-52	102	31
2-67-29-22	105	32
2-67-29-5	110	33
2-67-29-17	115	34
2-67-28-12	118	35
2-67-28-35	122	36
*2-67-28-23	124	37
2-67-28-51	126	38
2-67-28-18	128	39

Table 2.1-4. Well Sampling Priority by Parcel. (Page 2 of 5)

Well Number	Random Number	Priority
PARCEL C-1		
2-67-13-2	025	1
PARCEL C-2		
2-67-14-4	053	1
2-67-15-1	134	2
PARCEL C-3		
*2-67-15-2	055	1
*2-67-21-5	073	2
*2-67-16-2	098	3
PARCEL D		
2-67-21-9	018	1
*2-67-20-18	027	2
2-67-20-3	039	3
*2-67-20-27	052	4
*2-67-20-5	056	5
2-67-21-4	066	6
*2-67-20-6	087	7
*2-67-21-8	099	8
2-67-20-14	109	9
*2-67-20-30	111	10
PARCEL E		
2-67-28-16	023	1
2-67-28-57	030	2
2-67-28-42	042	3
2-67-28-33	045	4
2-67-28-40	057	5
2-67-28-21	063	6
2-67-28-3	065	7
2-67-28-8	071	8
2-67-28-32	076	9
2-67-28-37	083	10
2-67-28-24	092	11
2-67-28-2	097	12
2-67-28-29	106	13
2-67-28-25	113	14
2-67-28-30	139	15
2-67-28-34	140	16
2-67-28-6	148	17
2-67-28-5	150	18

Table 2.1-4. Well Sampling Priority by Parcel. (Page 3 of 5)

Priority	Well Number	Random Number
PARCEL F		
2-67-9-22	031	1
2-67-9-9	070	2
2-67-9-21	074	3
2-67-9-27	112	4
2-67-9-19	117	5
2-67-9-8	130	6
2-67-9-25	132	7
2-67-9-16	135	8
2-67-9-17	144	9
2-67-9-11	147	10
PARCEL G		
2-67-3-7	059	1
1-67-34-4	093	2
PARCEL H		
2-67-29-30	029	1
2-67-29-31	043	2
2-67-29-18	061	3
2-67-29-21	082	4
2-67-29-4	085	5
2-67-29-1	137	6
PARCEL I		
2-67-21-3	026	1
PARCEL J		
No Alluvial Candidate Wells		
PARCEL K		
*2-66-17-1	021	1
2-67-12-3	067	2
*2-67-12-2	149	3
PARCEL L		
2-67-16-9	005	1
2-67-16-10	022	2
2-67-11-1	024	3
2-67-3-10	047	4
*2-67-16-11	050	5
2-67-9-29	060	6

Table 2.1-4. Well Sampling Priority by Parcel. (Page 4 of 5)

Priority	Well Number	Random Number
2-67-2-4-	079	7
2-67-3-3	103	8
2-67-2-2	109	9
*2-67-16-13	138	10
2-67-16-8	143	11
PARCEL M		
No Alluvial Candidate Wells		
PARCEL N		
No Alluvial Candidate Wells		
PARCEL O		
2-67-2-2	002	1
2-67-2-11	013	2
1-67-13-58	036	3
1-67-35-23	037	4
1-67-35-9	077	5
1-67-35-2	078	6
1-67-36-1	080	7
2-67-1-16	088	8
2-67-2-5	091	9
2-67-2-10	094	10
1-67-35-1	119	11
1-67-35-21	127	12
1-67-35-24	133	13
2-67-2-1	142	14
2-67-2-9	145	15
PARCEL P		
1-67-36-15	006	1
PARCEL Q		
2-67-20-10	015	1
2-67-20-23	072	2
2-67-20-20	104	3
2-67-17-1	114	4
2-67-10-4	116	5
*2-67-19-7	123	6
2-67-20-2	146	7

Table 2.1-4. Well Sampling Priority by Parcel. (Page 5 of 5)

Priority	Well Number	Random Number
PARCEL R		
2-67-1-14	008	1
*1-67-35-28	016	2
2-66-6-1	034	3
1-67-35-22	058	4
*1-67-35-3	062	5
2-67-12-6	064	6
1-67-36-4A	107	7
1-67-35-26	121	8
1-67-25-3	125	9
*2-67-11-5	138	10
PARCEL S		
2-67-16-3	108	1
PARCEL T		
*2-67-30-3	003	1
*2-67-30-10	004	2
2-67-19-1	014	3
*2-67-30-11	017	4
*2-67-30-24	028	5
*2-67-30-12	069	6
*2-67-30-2	081	7
*2-67-30-4	120	8
*2-67-30-17	129	9
*2-67-30-5	136	10
PARCEL U		
No Alluvial Candidate Wells		

* - Designated Multi-Use Wells.

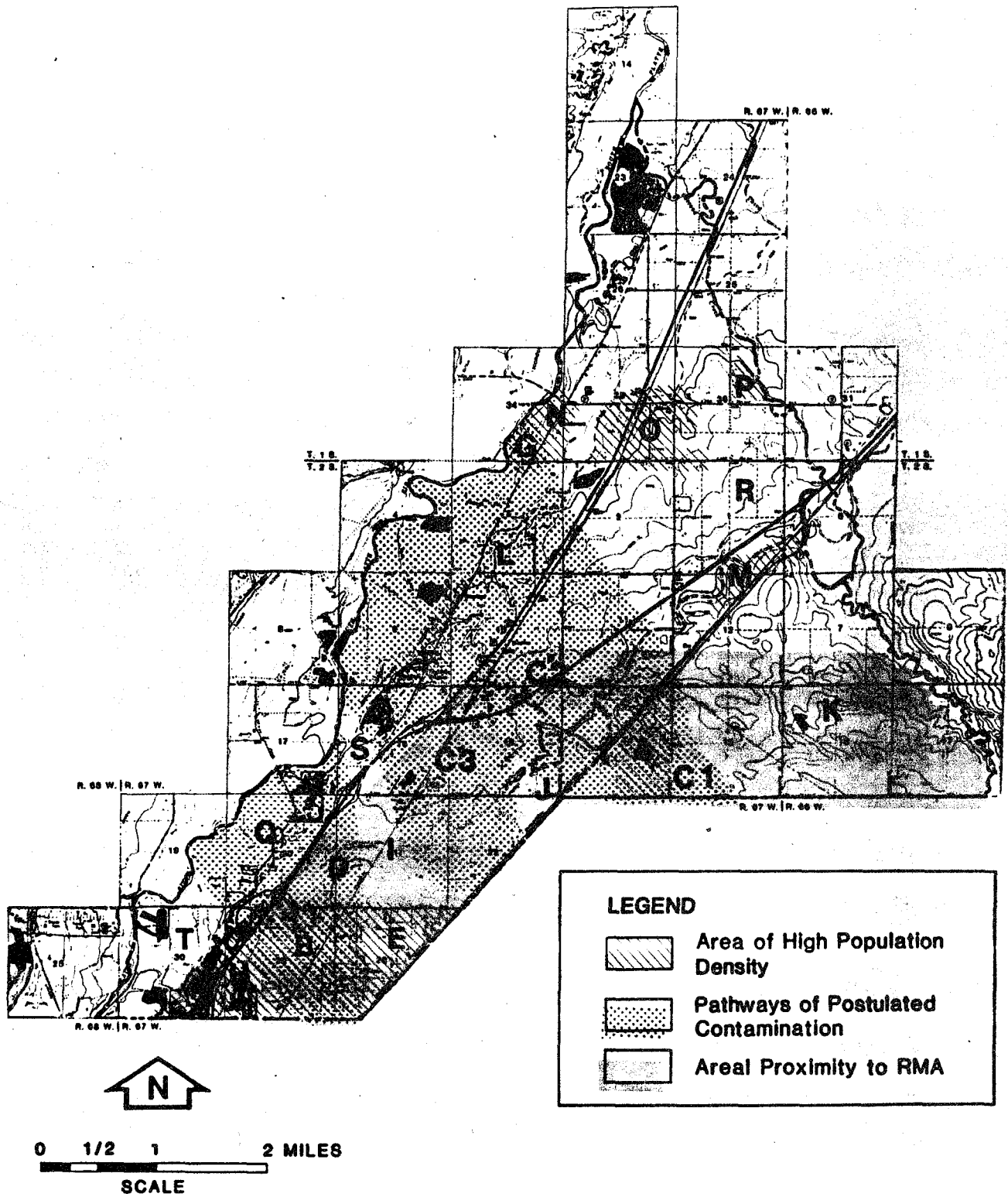

Figure 2.1-2
Parcels Identifications and
Areas of Elevated Concern

Prepared for:
U.S. Army Toxic and Hazardous
Materials Agency
Aberdeen Proving Ground, Maryland

Due to the highly variable nature of the data to be incorporated into the consumptive use sampling network design, a Stratified Random Sampling Design (SRSD) was utilized. The SRSD incorporates the concern areas identified above with a random selection of potential candidate wells. In essence the method employs the principle of random sampling, but because of considerable statistical variation, the sampling points (potential candidate wells) are grouped into parcels in such a way that variation within parcels is less than variation among parcels. The procedure allows any method to be used in selecting how many sampling points are to be used in each parcel.

Once the parcels were defined, the number of sampling units in each individual parcel was determined. The number of wells was based primarily on the premise of imminent public health concern and the size of the parcel. In addition, the 360° Program wells in each area were considered as they represented a predetermined selection. One hundred fifty potential candidate wells were assigned priorities using a random number ranking. Table 2.1-5 lists the numerical distribution of the number of candidate wells to be sampled in each parcel.

Upon field verification (Section 2.1.2) of information contained in the permit application and the MER, the candidate well will be accepted into the consumptive use well sampling network. This procedure will continue until all parcels have been occupied to the predetermined number (Table 2.1-5).

Bedrock Wells

Bedrock consumptive use wells identified during evaluation of the MER that are considered as candidate wells are listed in Table 2.1-6. These wells are incorporated into the sampling program to identify any potential contaminants in water supplies deriving water from the Denver Formation (bedrock).

Review of the MER records indicates that each of the candidate bedrock wells is considered to be a multi-use well. Sampling of these multi-use

Table 2.1-5. Numerical Distribution of 125 Consumptive Use Wells

Potential Wells in Parcel	Parcel A	Parcel Elevated Concern Ranking	Parcel Adjusted Priority Well Numbers	Parcel Area (Acres)	Parcel Ranking	Adjusted Areal Wells	360° Program Wells	Deep Multi-Use Wells	Total Wells
0	A	1	0	164	14	0	11	0	11
39	B	2	3	447	7	3	5	1	12
1	C-1	3	1	131	15	0	8	0	9
2	C-2	4	2	713	4	0	2	1	5
3	C-3	5	2	711	5	1	2	1	6
10	D	6	3	184	13	4	0	1	8
18	E	7	2	195	12	4	1	0	7
10	F	8	3	128	16	3	0	0	6
2	G	9	2	72	20	0	0	0	2
6	H	10	3	240	10	3	0	0	6
1	I	11	1	220	11	0	0	0	1
0	J	12	0	83	18	0	0	0	0
3	K	13	3	1,486	3	0	2	0	5
11	L	14	3	1,605	2	4	2	0	9
0	M	15	0	125	17	0	0	1	1
0	N	16	0	66	21	0	1	0	1
15	O	17	2	280	9	4	2	1	9
1	P	18	1	48	22	0	0	0	1
7	Q	19	2	530	6	4	0	0	6
10	R	20	2	2,696	1	4	2	0	8
1	S	21	1	77	19	0	0	0	1
10	T	22	2	359	8	4	0	0	6
0	U	Outside Project Area	NA	NA	NA	NA	5	0	5
Totals			38			38	43	6	125

Source: ESE, 1984.

wells will provide data on potential contamination exposure of several households.

These wells are categorized such that a representative sampling will provide data that is distributed throughout the project area. Wells will be field checked for acceptance into the sampling program in the order in which they are listed in Table 2.1-6.

Numerical Distribution

The number of consumptive use wells assigned to each parcel was determined from the prioritization of elevated concern ranking and parcel size. A total of 76 shallow consumptive use well sample locations will be sampled.

These 76 locations were distributed according to areal size and elevated concern ranking of each parcel. Thirty-eight were distributed according to areal size and 38 were distributed according to elevated concern ranking. In determining the number of well sample locations within each parcel, highest priority was given to parcels with highest elevated concern ranking and largest parcel size.

2.1.2 FIELD VERIFICATION OF CANDIDATE WELLS

Verification of the candidate wells will be conducted during an initial field visit. The following is a list of the data that will be obtained during this visit to each potential candidate well, the 360° Program wells, and the Army-deep wells.

1. The exact location as described in the well permit will be verified and described in detail.
 - a. Owners Name
 - b. Street Address
2. Is the well presently used as a domestic water supply?
Drinking, washing, or cooking?
3. Location of the well head on the property: i.e., in the basement, pumphouse, behind garage, or in the southwest corner of the back yard, etc.
4. Pump type.

Table 2.1-6. Bedrock/Multi-Use Well Sampling Locations.

Well Number	Priority
2-67-29-11	1
2-67-22-1	2
2-67-21-6	3
2-67-16-4	4
2-67-20-12	5
2-67-29-12	6
2-67-1-17	7
2-67-10-5	8
2-67-9-5	9
2-67-19-4	10

5. Annular space in casing around standpipe: i.e., ability to obtain a water level measurement.
6. Casing type.
7. Treatment, storage, or pressure systems to avoid.
8. Closest sampling point possible near the well head.
9. Is sufficient flushing of the system possible?
10. Ability to properly dispose of evacuated water prior to sampling.
11. Comments on the potential for a representative sample from the well.

Figure 2.1-3 is an example of a data sheet to record information obtained from the site verification visit and the sampling visit. Figure 2.1-4 presents the information requirements of the USATHAMA Data Management System (DMS). The system and abbreviations are described in the IR Data Management User's Guide (USATHAMA, 1984).

2.2 FIELD SAMPLING OF CONSUMPTIVE USE WELLS

The procedures below will be followed on the second visit to sites verified as acceptable using verification criteria discussed in Section 2.1.2. During this second visit, data will be gathered and a sample taken for each of the 125 verified consumptive use wells:

1. The depth to the water will be measured from the top of casing (if assessible).
2. If a pump is not located in the well, the depth to the water/sediment interface will be sounded and recorded. The volume of the water in the well will be calculated. If the well bore is occupied, the volume of water will be calculated from the permit information.
3. Samples will be taken after the fluid in the screen, well casing, and saturated annulus has been exchanged five times. After a review of the water distribution system with respect to the sampling point, an additional volume of water will be discharged to compensate for sample travel and mixing from the well head to the sample point. The optimum volume of additional purged water will be equal to five times the volume

RMA OFFPOST FIELD DATA SHEET

Well Number (ESE system) _____ Date _____
State Permit Number _____ 360° Prg Number _____
Permitted Use Code _____ Present Use _____
Location: Address _____
Resident/Owner _____
Phone # _____
Well Access _____

Producing Horizon: Alluvial _____ Bedrock _____ Formation Name _____
Date Installed _____ Pump Location/Type _____
Casing _____ Annular space at well head _____
Treatment, storage or pressure systems to avoid _____

Closest/Best Sampling point _____
Well Depth _____ Source _____
Screened Interval _____ Source _____
Static Water Level _____ Source _____
Five (5) Annular space/casing volumes= _____ Gallons
Ability to dispose of 5 casing volumes _____
Comments _____

SAMPLING

Weather Conditions (including Precipitation in previous 24 hrs.) _____

Date _____ Time _____

Collected by _____

Sampling Method _____

Container material _____ size _____ number of bottles _____

Temperature _____ pH _____

Specific conductance _____

Visual appearance _____

Storage Conditions _____

Significant Chemical Analyses _____

Comments _____

Figure 2.1-3
RMA Offpost Field Data Sheet

Prepared for:
U.S. Army Toxic and Hazardous
Materials Agency
Aberdeen Proving Ground, Maryland

	COLUMN
a. Installation	1
b. Functional Area	3
c. File Name	5
d. Site Type	8
e. Site Identification	12
f. Sample Date	22
g. Sample Program	27
f. Sample Depth	30
g. Sampling Technique	36
H. Analysis Date	37
i. Laboratory	42
j. Analysis Number	44
k. Test Name	50
l. Method Code	56
m. Measurement Boolean	60
n. Measurement Mantissa	62
o. Exponent	67
p. Units	70
q. Accuracy	74
r. Precision	78
s. Instrument Number	82
t. Initials Analyst	84
u. International Standard Code	87

Figure 2.1-4
 USATHAMA
 DATA MANAGEMENT SYSTEM
 INFORMATION REQUIREMENTS

Prepared for:
 U.S. Army Toxic and Hazardous
 Materials Agency
 Aberdeen Proving Ground, Maryland

of the system actually distributing water from the well head to the point of sample capture. In the event of low well yields (e.g., in the presence of fine-grained sediments), some wells may have slow recovery rates. Also, a large discharge of water may not be allowed by the well owner. Therefore, a decision to reduce the well purging to less than five volumes will be recommended by the ESE Geologist if excessive time would elapse while attempting to collect 1 or 2 samples from low-yielding wells or if a significant water discharge would pose a problem. The amount of actual fluid purge will be measured and recorded. Conductivity, pH, and temperature will be measured at the start, once during, and at the end of the fluid purging procedure. Temperature will be measured as required for instrument calibration. These data will be forwarded to USATHAMA at the end of sampling. Sampling will be accomplished by the owner's purging system or a stainless steel bailer. Care will be taken not to agitate the sample.

4. To protect the wells from contamination during sampling procedures, the following guidelines will be followed:
 - a. The stainless steel bailer will be flushed with distilled water prior to and after sample collection.
 - b. All sampling equipment will be protected from ground water contact by polyethylene plastic sheeting to prevent soil contamination from tainting the ground water samples. Plastic sheeting will not be moved from site to site in order to prevent cross-contamination.
 - c. Materials incidental to sampling such as bailer ropes (monofilament line) and tubing will be flushed with distilled water. Sampling equipment will be protected from ground surface contamination by clean plastic sheeting. No sampling will be accomplished when wind blown particles may contaminate the sample or sampling equipment.
5. Onsite measurements of water quality obtained during the sampling trip will consist of conductivity, temperature, and pH. These data will be presented in the Contamination

Assessment Reports. Calibration standards will be run and recorded prior to, during, and after each sampling day.

During sampling of each consumptive use well, information regarding the sampling will be kept in a notebook. The following data will be collected:

1. Well number;
2. Date;
3. Time;
4. Static water level (if accessible);
5. Depth of well;
6. Number of bailer volumes removed (if applicable);
7. Pumping rate (if applicable);
8. Time of pumping (if applicable);
9. Drawdown water level (if accessible);
10. In situ water quality measurements such as pH, specific conductance, and temperature;
11. Fractions sampled and preservatives;
12. Weather conditions and/or miscellaneous observations; and
13. Signature of sampler and date.

Samples will be collected in a manner which will minimize aeration and prevent oxidation of reduced compounds. The sample bottle should be partially filled with the water to be sampled, and the contents should be agitated and discarded prior to filling the bottle with sample. Volatile samples will be collected in duplicate directly from the discharge point and placed in the canisters containing activated carbon provided to prevent contamination. Volatile fractions will not be filtered. If the preserved volatile sample bottle containing the volatile fraction is contaminated by dropping the septum or touching the septum or lips of the bottle, it will be discarded and a clean bottle issued and labeled. Under no circumstances will volatile fractions be transferred from other sampling containers. All samples for organic chemical analyses should be placed in amber glass bottles with teflon lined lids. The bottles will be filled to the top and capped securely.

11/09/84

Samples for inorganic chemical analyses will be placed in polyethylene bottles. The bottles will be filled to the top and capped securely. In between samples, any sampling equipment will be rinsed and cleansed, as described in the QC plan (ESE, 1984).

Each sample will be carefully labeled and will be shipped in styrofoam ice chests and will be kept below 4°C from time of sample collection until analysis. The products of ground water sampling will be:

1. A water sample from each well;
2. A replicate water sample from one of the wells;
3. Onsite measurements of conductivity, temperature, and pH; and
4. Depth-to-water and depth-to-sediment/water interface readings at each well.

All field data will be recorded in a format directly compatible with the USATHAMA DMS input requirements. All field log books will be provided to USATHAMA at the termination of the study.

2.3 SAMPLE SHIPMENT/CHAIN OF CUSTODY

The ESE Site Geologist will serve as a Sampling Team Leader and will supervise and assist in the sampling of all ground water and surface water sampling stations. Samples will be labeled and preserved in the field. A log sheet will be filed and signed in by the Site Geologist to serve as a check that all samples and operations are complete. Samples will be packed in styrofoam ice chests with sufficient ice to maintain $\leq 4^{\circ}\text{C}$ during transport to the laboratory. The ice will be double-bagged to prevent contact of the melt water with the samples. All samples will be checked for integrity and lid closure to prevent leakage.

The sampling logistics will occur as follows. The time elapsed between the first sample collection and initiation of processing in the laboratory will be approximately 24 to 30 hours, based on transportation schedules.

The Chemical Analysis Supervisor will be notified of the shipment of samples and the estimated time of arrival of the samples being given.

The Chemical Analysis Supervisor or a designate will receive the samples, verify the contents, and sign the log sheet. Samples are stored at ESE in the 4°C-refrigerator under control of the Data Management Supervisor in the Sample Control Center. The procedures for sample fraction control during analysis are described in the Data Management Plan.

Any samples which are leaking, any situations in which holding times are not met, or other problems which may compromise the data, are noted at the time of receipt of the samples and reported to the Quality Assurance (QA) Supervisor for development of corrective action. The QA Supervisor verifies the chain-of-custody record of each sample set.

3.0 GEOTECHNICAL PROGRAM

3.1 MONITOR WELL NETWORK AND RATIONALE

The proposed monitoring well network includes the installation of 30 new wells (29 alluvial and 1 bedrock), and is designed to meet the following objectives:

1. Characterization of ground water quality in population centers and other locations of ground water use by human, food chain crops, and livestock;
2. Delineation of expected contaminated ground water plume boundaries;
3. Hydrogeologic description of the aquifer systems affecting contaminant transport;
4. Characterization of background water quality in areas unaffected by RMA sources;
5. Characterization of discharge from the Denver aquifer in contaminated areas near the RMA boundary; and
6. Characterization of ground water/surface water interactions for potentially contaminated offpost surface water.

Twenty-nine ground water monitoring wells (twenty-eight alluvial and one bedrock) will be installed in the Offpost Contamination Study Area to the north and northwest of RMA (see map pocket). One background shallow monitor well will be installed near the southeast corner of RMA. The wells will be constructed to maximize the probability of obtaining representative hydrogeologic data, intercepting the contamination plume; and determining the interaction of irrigation ditches, surface water, shallow ground water and deep bedrock ground water.

3.1.1 WELL LOCATION RATIONALE

Proposed monitor well sites are identified in Figure 3.1-1. The specific location of each well is flexible within a radius of 60 meters (m) [200 feet (ft)] from the proposed identified site. This flexibility may be needed in obtaining easements and avoiding powerlines and other utility structures. Each well site has been identified to define at least one of the following:

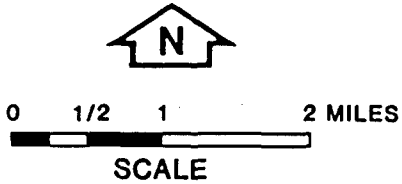
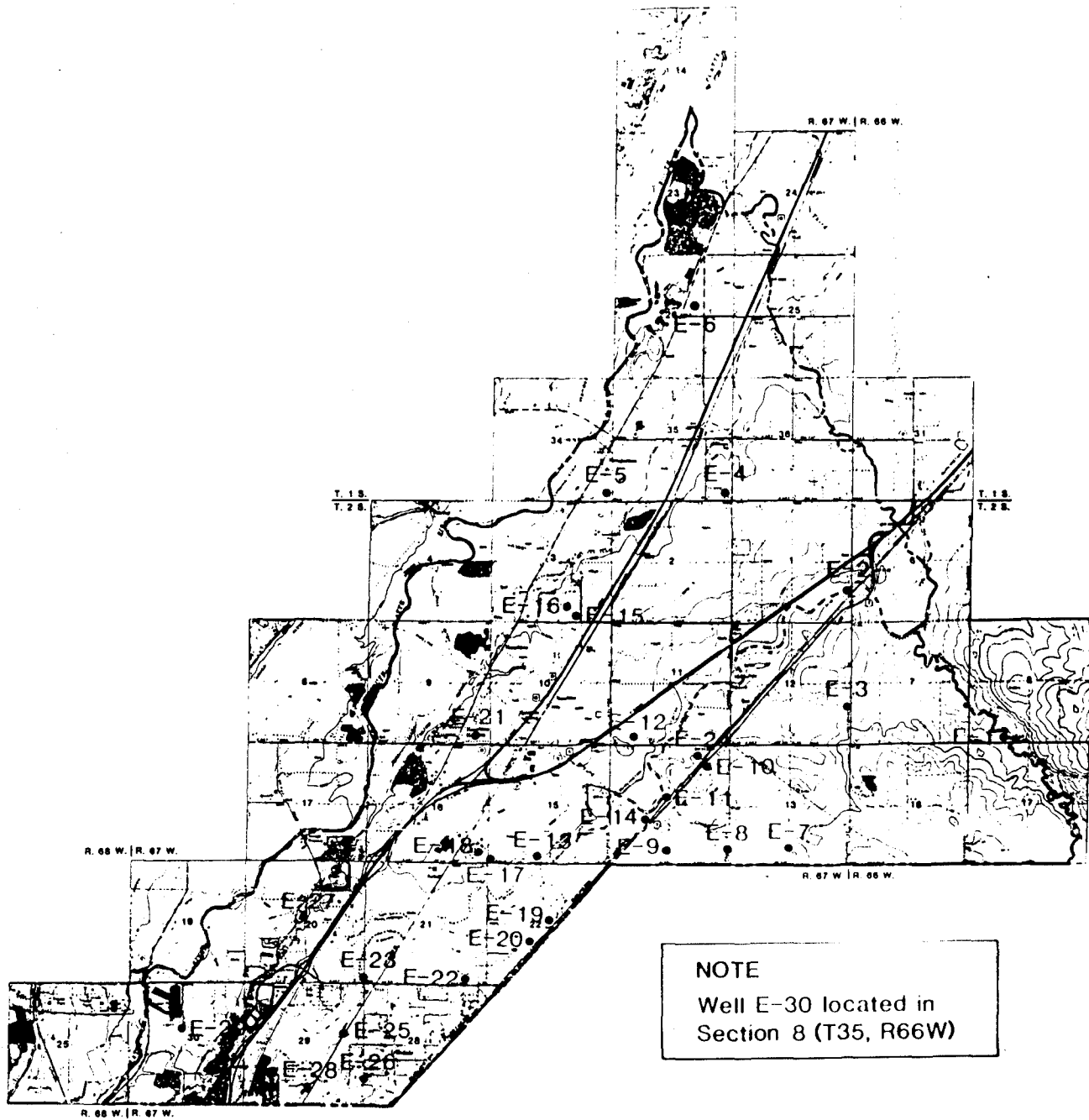

SOURCE: ESE, 1984

Figure 3.1-1
Proposed Monitor Well Locations

Prepared for:
**U.S. Army Toxic and Hazardous
Materials Agency**
Aberdeen Proving Ground, Maryland

1. Surface water and shallow ground water relationships;
2. Local hydrogeology;
3. Ground water quality beneath populated areas;
4. Bedrock hydrogeology;
5. Irrigation ditch and shallow ground water relationships;
6. Contaminant plume delineation; and
7. Background ground water quality.

Generally a site was chosen that might provide more than one category of the information listed above. Proposed well site locations and the siting rationale for selecting each site is listed in Section 3.2. A description of the siting rationale addressed in Section 3.2 is given below.

Surface Water and Shallow Ground Water Relationships

The interaction of surface water and shallow ground water defines how contaminants move from either ground water to surface water or surface water to ground water. The flow time and potential attenuation of contaminants is governed by the rate and direction of this interaction.

Local Hydrogeology

The hydrogeology of the study area needs to be defined over the entire project area so that impacts of offsite hydrogeologic water systems can be specifically defined. Minor variations in hydrologic properties, formation composition and the degree of saturation may cause significant variation in contaminant migration. Some sites were located to address water quality in the areas adjacent to First and Second Creeks.

Ground Water Quality Beneath a Specific Populated Areas

Identification of impacts to consumptive use supplies is the primary reason for conducting this offsite contamination assessment. Some sites are located immediately up gradient from populated areas to provide site specific water quality data for population exposure assessment.

Bedrock Hydrogeology

The interaction of shallow ground water with bedrock ground water is related to the potential impact of migrating contaminants to the regional bedrock (Denver and Arapahoe) water quality. If hydraulic gradients in

the offsite area are towards the bedrock (downward), degradation of Denver and Arapahoe formation waters may occur. In addition, subsurface conditions might exist such that contaminated water may be entering the alluvium from the Denver and Arapahoe Formations (upward degradation). Paleotopographic lows resulting from erosion prior to deposition of the alluvium and the subsequent infilling of these bedrock lows with alluvium could possibly create a hydrogeologic situation conducive to interformational migration of contaminated ground water from the bedrock aquifers to the alluvial aquifer. Such conditions most likely exist in the area north of RMA and south of Boller's well. This is one of the areas where wells in the Denver will be required to properly define this contaminant migration and geohydrologic conditions. The Denver and Arapahoe Formations are used for consumptive use throughout the Denver Basin.

Irrigation Ditch and Shallow Ground Water Relationships

Water quality and flow relationships between surface water systems crossing irrigation ditches relate directly to the migration potential of contaminants to Barr Lake and other locations outside of the study area. Some sites will be used to determine the possibility of contaminated ground water entering the irrigation ditch system.

Contaminant Plume Delineation

There are three probable plumes identified from previous studies in the project area. These three areas have not been delineated in the previous studies. Several sites will help to identify the spatial distribution of contaminants in these plume migration pathways. These paths of suspected contaminant migration were determined from the location of contaminant sources, locations of contaminant plumes on RMA, bedrock contour maps of the area, and flow directions derived from ground water contour maps.

Background Ground Water Quality

One site will be located near the southeast corner of RMA. This site will assist in the identification of water quality prior to water entering the RMA hydrologic system. Impacts due solely to RMA can only be determined upon assessing impacts by other users upgradient from RMA.

3.2 ANTICIPATED CONDITIONS

3.2.1 WELL SITE DESCRIPTION

Proposed Well E-1

Location: 780 meters (m) (2,550 ft) north of the south section line, and 655 m (2,150 ft) west of the east section line of Section 10 (T2S, R67W). The well will be located on the east side of the Union Pacific Railroad access road.

Siting Rationale: 1) Contaminant plume delineation; and 2) Local hydrogeology.

Expected Site Conditions: The total depth of the well is anticipated to be 14 m (45 ft). Depth to the water table has been estimated to be 9 m (28 ft). Lithologic units present include a Holocene-Pleistocene Age eolian sand overlying Pleistocene alluvial deposits. The overlying eolian units are composed of fine to medium grained sand. The alluvium is expected to be composed of silty to clayey sands interlayered with fine to coarse grained gravelly sands. The uppermost bedrock unit in the area is the Arapahoe Formation.

The borehole will be drilled to the alluvial-bedrock contact. The well will be completed in alluvium, with a screened interval extending from within 3 m of the top of the water table to the top of the bedrock.

Proposed Well E-2

Location: 290 m (950 ft) north of the south section line, and 3 m (10 ft) east of the west section line of Section 6 (T2S, R66W). The well will be located on the east side of Potomac Street, south of the Burlington Northern Railroad tracks.

Siting Rationale: 1) Irrigation ditch and shallow ground water relationships; 2) Ground water quality beneath populated areas; and 3) Local hydrogeology.

Expected Site Conditions: The total depth of the well is anticipated to be 14 m (45 ft). Depth to the water table has been estimated to be 10 m (32 ft). Lithologic units present include upper eolian sands of Holocene-Pleistocene Age and a lower alluvial Pleistocene unit. The eolian unit is composed of fine to medium grained wind blown sand. These sands

overlie alluvial sediments composed of fine to coarse grained sands interlayered with silty and clayey sands. The uppermost bedrock unit in this area is the Denver Formation.

The borehole will be drilled to the top of the alluvial-bedrock contact. The well will be completed in alluvium, with a screened interval extending from within 3 m of the top of the water table to the top of the bedrock.

Proposed Well E-3

Location: 358 m (1,175 ft) north of the south section line and 3 m (10 ft) west of the east section line of Section 12 (T2S, R67W). The well will be located on the west side of Potomac Street, north of 104th Avenue.

Siting Rationale: 1) Contaminant plume delineation; and 2) Local hydrogeology.

Expected Site Conditions: The total depth of the well is anticipated to be 11 m (35 ft). Depth to the water table has been estimated to be 7 m (23 ft). Lithologic units present include eolian sands overlying Pleistocene alluvium. Unconsolidated deposits (soils) encountered will be fine to medium grained wind blown sands at the surface. Below these sands, alluvium composed of sands ranging from silty and clayey to coarse grained will be encountered. The uppermost bedrock unit in this area is the Denver Formation.

The borehole will be drilled to the alluvial-bedrock contact. The well will be completed in the alluvium, with the screened interval extending from within 3 m of the top of the water table to the top of the bedrock.

Proposed Well E-4

Location: 3 m (10 ft) north of the south section line, and 884 m (2,900 ft) west of the east section line of Section 2 (T2S, R67W). The well will be located on the north side of 112th Avenue, east of Havana Street.

Siting Rationale: 1) Contaminant plume delineation; and 2) Local hydrogeology.

Expected Site Conditions: The total depth of the well is anticipated to be 18 m (60 ft). Depth to the water table has been estimated to be 8 m (25 ft). Lithologic units present include Holocene-Pleistocene Age eolian sands overlying Pleistocene alluvium. The eolian unit is composed of well sorted, fine to medium sands. The alluvium is expected to be composed of coarse sand intermixed with silty sands. There may be some gravelly sand. The uppermost bedrock unit in this area is the Arapahoe Formation.

The borehole will be drilled to the alluvial-bedrock contact. The well will be completed in the alluvium, with the screened interval extending from within 3 m of the top of the water table to the top of the bedrock.

Proposed Well E-5

Location: At the intersection of the north and east section lines of Section 3 (T2S, R67W). The well will be located on the north side of east 120th Avenue.

Siting Rationale: 1) Ground water quality beneath populated areas; 2) Contaminant plume delineation; 3) Local hydrogeology; and 4) Irrigation ditch and shallow ground water relationships.

Expected Site Conditions: The total depth of the well is anticipated to be 12 m (40 ft). Depth to the water table has been estimated to be 2 m (6 ft). Lithologic units present include the Post-Piney Creek and Piney Creek alluvium, and Pleistocene alluvium. The upper alluvium (Piney Creek) is composed of gravel, sand, silt, and clay. The lower Pleistocene alluvium is composed of similar to slightly coarser material. The uppermost bedrock unit in this area is the Arapahoe Formation.

The borehole will be drilled to the alluvial-bedrock contact. The well will be completed in the alluvium, with the screened interval extending from within 3 m of the top of the water table to the top of the bedrock.

Proposed Well E-6

Location: 1,120 m (3,675 ft) north of the south section line and 3 m (10 ft) west of the east section line of Section 11 (T2S, R67W). The well will be located on the west side of Peoria street, north of the O'Brian Canal.

Site Rationale: 1) Contaminant plume delineation; 2) Irrigation ditch and shallow ground water relationships; and 3) Local hydrogeology.

Expected Site Conditions: The total depth of the well is anticipated to be 14 m (45 ft). Depth to the water table has been estimated to be 6 m (20 ft). Lithologic units present include a Holocene-Pleistocene eolian sand unit overlying Pleistocene alluvium. The eolian sand is a well-sorted, fine to medium-grained, windblown sand. The alluvium is composed of coarse gravelly sands with some silt layers. This site is located along the northern edge of the Denver Formation.

The borehole is anticipated to be completed at the Denver Formation, however, the borehole may be completed at the top of the Arapahoe Formation. The well will be completed in the alluvium, with the screened interval extending from within 3 m of the top of the water table to the top of the bedrock.

Proposed Well E-7

Location: 3 m (10 ft) north of the south section line and 805 m (2,640 ft) east of the west section line of Section 13 (T2S, R67W). The well will be located along East 96th Avenue, north of the road, and south of First Creek.

Siting Rationale: 1) Contaminant plume delineation; and 2) Local hydrogeology.

Expected Site Conditions: The total depth of the well is anticipated to be 9 m (30 ft). Depth to the water table has been estimated to be 1 m (3 ft). Lithologic units present include the Upper Holocene to Post Piney Creek and Piney Creek alluvium and an underlying Pleistocene alluvium. The upper alluvium is composed of gravel, silt and clay of stream flood plains. The lower alluvium is a somewhat coarser gravelly

sand with some silty and clayey sands interspersed. The uppermost bedrock unit in this area is the Denver Formation.

The borehole will be drilled to the alluvial-bedrock contact. The well will be completed in the alluvium, with the screened interval extending from 1 m below the land surface to the top of the bedrock.

Proposed Well E-8

Location: 3 m (10 ft) north of the south section line and 1,067 m (3,500 ft) east of the west section line of Section 13 (T2S, R67W). The well will be located along East 96th Avenue, north of the road, and east of First Creek.

Siting Rationale: 1) Contaminated plume delineation; and 2) Local hydrogeology.

Expected Site Conditions: The total depth of the well is anticipated to be 6 m (20 ft). Depth to water table has been estimated to be 3 m (9 ft). Lithologic units present include the Post-Piney Creek and Piney Creek alluvium overlying Pleistocene alluvium. The upper alluvial sediments are composed of coarse sand, sands with silt and clay layers. The lower Pleistocene alluvium is composed of medium to coarse sands, with some gravel interspersed with silty and clayey layers. The uppermost bedrock unit in this area is the Denver Formation.

The borehole will be drilled to the alluvial-bedrock contact. The well will be completed in the alluvium, with the screened interval extending from within 3 m of the top of the water table to the top of the bedrock.

Proposed Well E-9

Location: 15 m (50 ft) north of the south section line and 808 m (2,650 ft) east of the west section line of Section 14 (T2S, R67W). The well will be located north of East 96th Avenue, and midway between Havana Street to the west of Peoria Street to the east.

Siting Rationale: 1) Contaminant plume delineation; and 2) Local hydrogeology.

Expected Site Conditions: The total depth of the well is anticipated to be 6 m (20 ft). Depth to the water table has been estimated to be 1 m (3 ft). The lithologic units present is the Slocum alluvium of Pleistocene Age overlying the Denver Formation. The Slocum alluvium is a cobble gravel which may contain boulders. This unit is expected to contain mostly coarse, gravelly sand with some cobbles. There may be finer grained silty sands and clayey sands underlying the gravels.

The borehole will be drilled to the alluvial-bedrock contact. The well will be completed in the alluvium, with the screened interval extending from approximately 1 m below the land surface to the top of the bedrock.

Proposed Well E-10

Location: 411 m (1,350 ft) west of the east section line and 305 m (1,000 ft) south of the north section line of Section 14 (T2S, R67W). The well will be located along Colorado Route 2, west of the road.

Siting Rationale: 1) Contaminant plume delineation; 2) Bedrock hydrogeology; and 3) Local hydrogeology.

Expected Site Conditions: The total depth of the well is anticipated to be 3 m (10 ft). Depth to the water table has been estimated to be 1.5 m (5 ft). Lithologic units present include the Holocene-Pleistocene eolian sand overlying a Pleistocene alluvium. The windblown sand is fine to medium grained. The alluvium is composed of a gravelly sand with some silt and clay layers. The uppermost bedrock unit in this area is the Denver Formation.

The borehole will be drilled to the alluvium-bedrock contact. The well will be completed in the alluvium, with the screened interval extending from 1 m below the land surface to the top of the bedrock.

Proposed Well E-11

Location: 732 m (2,400 ft) east of the west section line and 625 m (2,050 ft) south of the north section line of Section 14 (T2S, R67W).

The well will be located along Colorado Route 2, on the west side of the road, at First Creek.

Siting Rationale: 1) Contaminant plume delineation; 2) Irrigation ditch shallow ground water relationships; 3) Surface water and shallow ground water relationships; and 4) Local hydrogeology.

Expected Site Conditions: The total depth of the well is anticipated to be 11 m (35 ft). The depth to the water table has been estimated to be 0 to 1.5 m (0-5 ft). The lithologic units present are the Post-Piney Creek and Piney Creek alluvium, which cover Pleistocene alluvium.

Gravel, sand, silt and clay overlie the alluvial channel deposits which should contain coarser sands and gravels. The uppermost bedrock unit in this area is the Denver Formation.

The borehole will be drilled to the alluvium-bedrock contact. The well will be completed in the alluvium, with the screened interval extending from approximately 1 m below the land surface to the top of the bedrock.

Proposed Well E-12

Location: 389 m (1,275 ft) east of the west section line and 3 m (10 ft) north of the south section line of Section 11 (T2S, R67W). The well will be located along East 104th Avenue, north of the road.

Siting Rationale: 1) Contaminant plume delineation; 2) Irrigation ditch and shallow ground water relationships; and 3) Local hydrogeology.

Expected Site Conditions: The total depth of the well is anticipated to be 14 m (45 ft). The depth to the water table has been estimated to be 10 m (33 ft). The lithologic units present include Holocene-Pleistocene eolian sands overlying Pleistocene alluvium. Surface deposits will be fine to medium grained, well sorted sands of the eolian unit overlying coarser alluvial sediments. The alluvial sediment will be composed of gravelly sands, interbedded with silts and clays. The uppermost bedrock unit in this area is the Denver Formation.

The borehole will be drilled to the alluvium-bedrock contact. The well will be completed in the alluvium, with the screened interval extending from within 3 m of the top of the water table to the top of the bedrock.

Proposed Well E-13

Location: 701 m (2,300 ft) east of the west section line, along the south section line of Section 15 (T2S, R67W). The well will be located north of east 96th Avenue between the Burlington Ditch and the O'Brian Canal.

Siting Rationale: 1) Contaminant plume delineation; 2) Irrigation ditch and shallow ground water relationships; and 3) Local hydrogeology.

Expected Site Conditions: The total depth of the well is anticipated to be 11 m (35 ft). The depth to the water table has been estimated to be 6 m (18 ft). The lithologic units present include the Slocum alluvium of Pleistocene Age which overlies an earlier Pleistocene alluvium. The Slocum alluvium is a very coarse alluvial unit, composed of gravelly sands and cobbles. The uppermost unit in this area is the Denver Formation.

The borehole will be drilled to the alluvium-bedrock contact. The well will be completed in the alluvium, with the screened interval extending from within 3 m of the top of the water table to the top of the bedrock.

Proposed Well E-14

Location: 549 m (1,800 ft) east of the west section line and 488 m (1,600 ft) north of the south section line of Section 14 (T2S, R67W). The well will be located along Colorado Route 2, on the east side of the road.

Siting Rationale: 1) Contaminant plume delineation; 2) Ground water quality beneath populated areas; and 3) Local hydrogeology.

Expected Site Conditions: The total depth of the well is anticipated to be 15 m (50 ft). The depth to the water table has been estimated to be 16 m (53 ft). The lithologic units present include Holocene-Pleistocene eolian sands which cover Pleistocene alluvial deposits. The fine to medium grained well sorted eolian sands overlie the coarse sands and gravels of alluvial deposits. This borehole will also intersect layers of silts, clays and fine grained sands. The uppermost bedrock unit in this area is the Denver Formation.

The borehole will be drilled to the alluvium-bedrock contact. The well will be completed in the alluvium, with the screened interval extending from within 3 m of the top of the water table to the bedrock.

Proposed Well E-15

Location: 3 m (10 ft) east of the west section line and 960 m (3,150 ft) north of the south section line of Section 14 (T2S, R67W). The well will be located along Havana Street, east of the road, between the Burlington Ditch and the O'Brian Canal.

Siting Rationale: 1) Irrigation ditch and shallow ground water relationships; 2) Contaminant plume delineation; and 3) Local hydrogeology.

Expected Site Conditions: The total depth of the well is anticipated to be 9 m (30 ft). The depth to the water table has been estimated to be 2 m (6 ft) below the surface. The lithologic units present include the Holocene Post-Piney Creek and Piney Creek alluvium which is underlain by Pleistocene alluvium. Gravels, silts, sands and clays of the upper alluvium overlie the medium to coarse gravelly sands in the lower alluvial deposits. These sands may be interbedded with layers of silts and clays. The uppermost bedrock unit in this area is the Denver Formation.

The borehole will be drilled to the top of the alluvium-bedrock contact. The well will be completed in the alluvium, with the screened interval extending from 2 m below the land surface to the top of the bedrock.

Proposed Well E-16

Location: 411 m (1,350 ft) west of the east section line and 3 m (10 ft) south of the north section line of Section 10 (T2S, R67W). The well will be located along East 112th street, south of the road, along an old railroad spur line.

Siting Rationale: 1) Contaminant plume delineation; and 2) Local hydrogeology.

Expected Site Conditions: The total depth of the well is anticipated to be 17 m (55 ft). The depth to the water table has been estimated to be 7 m (23 ft). The lithologic units present include Holocene-Pleistocene eolian sands which overlie Pleistocene alluvium. Fine to medium grained, well-sorted wind blown sands overlie the alluvium which is composed primarily of coarse, gravelly sands interbedded with silty and clayey sands. The uppermost bedrock unit in the area is the Arapahoe Formation.

The borehole will be drilled to the top of the alluvium-bedrock contact. The well will be completed in the alluvium, with the screened interval extending from within 3 m of the top of the water table to the top of the bedrock.

Proposed Well E-17

Location: 625 m (2,050 ft) west of the east section line and 3 m (10 ft) north of the south section line of Section 10 (T2S, R67W). The well will be located along East 104th Avenue, on the north side of the road.

Siting Rationale: 1) Contaminant plume delineation; and 2) Local hydrogeology.

Expected Site Conditions: The total depth of the well is anticipated to be 14 m (45 ft). The depth to the water table has been estimated to be 9 m (30 ft) below the surface. Lithologic units present include Post-Piney Creek or Piney Creek alluvium overlying Pleistocene alluvium. The surface deposits (soils) are composed of sands and gravels with layers of silts and clays. The underlying alluvium is composed of gravelly medium to coarse grained sands. This lower alluvium may also contain some layers of silty and clayey sands. The uppermost bedrock unit in the area is the Arapahoe Formation.

The borehole will be drilled to the top of the alluvium-bedrock contact. The well will be completed in the alluvium, with the screened interval extending from within 3 m of the top of the water table to the top of the bedrock.

Proposed Well E-18

Location: 91 m (300 ft) east of the west section line and 381 m (1,250 ft) north of the south section line of Section 2 (T2S, R67W). The well will be located along the west side of Havana Street, north of East 112th Avenue.

Siting Rationale: 1) Contaminant plume delineation; and 2) Local hydrogeology.

Expected Site Conditions: The total depth of the well is anticipated to be 21 m (70 ft). The depth to the water table has been estimated to be 4 m (14 ft). Lithologic units present include Post-Piney Creek or Piney Creek alluvium overlying Pleistocene alluvium. The gravels, sands, silts, and clays of the Piney Creek layer overlie somewhat coarser sediments in the Pleistocene alluvium. The basal layers will probably be medium to coarse gravelly sands with some cobbles. The uppermost bedrock unit in this area is the Arapahoe Formation.

The borehole will be drilled to the top of the alluvium-bedrock contact. The well will be completed in the alluvium, with the screened interval extending from within 3 m of the top of the water table to the top of the bedrock.

Proposed Well E-19

Location: 6 m (20 ft) east of the west section line and 808 m (2,650 ft) north of the south section line of Section 11 (T2S, R67W). The well will be located along Havana street, east of the road.

Siting Rationale: 1) Contaminant plume delineation; and 2) Local hydrogeology.

Expected Site Conditions: The total depth of the well is anticipated to be 20 m (65 ft). The depth to the water table has been estimated to be 9 m (30 ft). Lithologic units present include Holocene-Pleistocene eolian sands which overlie Pleistocene alluvium. The upper strata are composed of fine to medium grained, well sorted, windblown sands. The underlying alluvium is composed of medium to coarse grained sands and gravelly sand with silty and clayey sand layers interspersed. The uppermost bedrock formation in the area is the Arapahoe Formation.

The borehole will be drilled to the top of the alluvium-bedrock contact. The well will be completed in the alluvium, with the screened interval extending from within 3 m of the top of the water table to the top of the bedrock.

Proposed Well E-20

Location: 518 m (1,700 ft) west of the east section line and 610 m (2,000 ft) north of the south section line of Section 34 (T2S, R67W). The well will be located west of the South Platte River, south of East 124th Avenue, and west of the levy road. A USGS stream gaging station is located across the stream from this location.

Siting Rationale: 1) Contaminant plume delineation; 2) Local hydrogeology; and 3) Surface water and shallow ground water relationships.

Expected Site Conditions: The total depth of the well is anticipated to be 15 m (50 ft). The depth to the water table has been estimated to be 0 to 2 m (0-6 ft). Lithologic units present include Post-Piney Creek or Piney Creek alluvium which overlies Pleistocene alluvium. The sands, gravels, silts and clays overlie alluvial sediments composed of coarse gravelly sands. The uppermost bedrock formation in the area is the Arapahoe Formation.

The borehole will be drilled to the top of the alluvium-bedrock contact. The well will be completed in the alluvium, with the screened interval extending from within 1 m of the top of the water table to the bedrock.

Proposed Well E-21

Location: 488 m (1,600 ft) east of the west section line and 15 m (50 ft) north of the south section line of Section 10 (T2S, R67W). The well will be located on east 104th Avenue, north of the road, and west of U.S. Highway 85.

Siting Rationale: 1) Ground water quality beneath populated areas; 2) Contaminant plume delineation; and 3) Local hydrogeology.

Expected Site Conditions: The total depth of the well is anticipated to be 12 m (40 ft). The depth to water table has been estimated to be 6 m

(21 ft). Lithologic units present include the Post-Piney Creek or Piney Creek alluvium which overlies Pleistocene alluvium. The gravels, sands, silts and clays of the alluvium overlie alluvial deposits composed of silty and clayey sands underlain by coarser sands and gravels. The uppermost bedrock formation in the area is the Arapahoe Formation.

The borehole will be drilled to the top of the alluvium-bedrock contact. The well will be completed in the alluvium, with the screened interval extending from within 3 m of the top of the water table to the top of the bedrock.

Proposed Well E-22

Location: 709 m (2,325 ft) east of the west section line and 793 m (2,600 ft) south of the north section line of Section 3 (T2S, R67W). The well will be located along Brighton Road, on the west side of the road.

Siting Rationale: 1) Contaminant plume delineation; and 2) Local hydrogeology.

Expected Site Conditions: The total depth of the well is anticipated to be 12 m (40 ft). The depth to the water table has been estimated to be 2 m (5 ft). Lithologic units present include the Piney Creek alluvium which overly Pleistocene alluvium near the surface of the drill location. The overlying alluvium consists of sands, gravels, silts, and clays. The underlying alluvial sediments are composed of coarse gravelly sands and silty and clayey sands. The uppermost bedrock formation in the area is the Arapahoe Formation.

The borehole will be drilled to the top of the alluvium-bedrock contact. The well will be completed in the alluvium, with the screened interval extending from within 2 m of the top of the water table to the top of the bedrock.

Proposed Well E-23

Location: 290 m (950 ft) west of the east section line and 427 m (1,400 ft) north of the south section line of Section 9 (T2S, R67W). The well will be located along the west side of Brighton Road.

Siting Rationale: 1) Ground water quality beneath populated areas; 2) Contaminant plume delineation; and 3) Local hydrogeology.

Expected Site Conditions: The total depth of the well is anticipated to be 11 m (35 ft). The depth to the water surface has been estimated to be 6 m (21 ft). Lithologic units present include the Upper Pleistocene Louvier's alluvium which is underlain by early Pleistocene alluvium deposits. The upper alluvium is composed of sand, gravel and clay and may contain some calcium carbonate (CaCO_3). The lower alluvium will consist of gravelly sands with some cobbles overlain by siltier sands and clayey sands. The uppermost bedrock formation in the area is the Arapahoe Formation.

The borehole will be drilled to the top of the alluvium-bedrock contact. The well will be completed in the alluvium, with the screened interval extending from within 3 m of the top of the water table to the top of the bedrock.

Proposed Well E-24

Location: 549 m (1,800 ft) east of the west section line and 488 m (1,600 ft) north of the south section line of Section 14 (T2S, R67W). The well will be located along Colorado Route 2, on the east side of the road. This well is located at the same site as well E-14, however, it will be completed into the Denver Formation.

Siting Rationale: 1) Ground water quality beneath populated areas; 2) Shallow ground water and bedrock ground water quality relationships; 3) Local hydrogeology; and 4) Contaminant plume delineation.

Expected Site Conditions: The total depth of the well is anticipated to be 40 m (130 ft). The depth to the water table has been estimated to be 16 m (53 ft). Lithologic units present include Holocene-Pleistocene eolian sand which overlies Pleistocene alluvium. Depth to bedrock is approximately 15 m (50 ft). Fine to medium grained windblown sand

overlies coarse grained alluvium composed of gravelly sands with some silt and clay. During core drilling of the Denver Formation, interbedded soft shales and harder sandstone units will be encountered.

This borehole will be drilled down through the alluvium-bedrock contact and will extend approximately 24 m (78 ft) into the lower Denver Formation. The well will be completed in the first water bearing sandstone (aquifer) encountered in the Denver Formation with the screened interval within the sandstone interval.

Proposed Well E-25

Location: 594 m (1,950 ft) east of the west section line and 3 m (10 ft) south of the north section line of Section 16 (T2S, R67W). The well will be located along East 104th Avenue, on the south side of the road between Bull Seep Ditch and Fulton Ditch.

Siting Rationale: 1) Contaminant plume delineation; 2) Ground water quality beneath populated areas; 3) Irrigation ditch and shallow ground water relationships; and 4) Local hydrogeology.

Expected Site Conditions: The total depth of the well is anticipated to be 12 m (40 ft). The depth to the water surface has been estimated to be 2 m (5 ft). Lithologic units present include the Piney Creek alluvium which overlies Pleistocene alluvium at the drill site. The Piney Creek alluvium consists of sands, gravels, silts and clays. The Pleistocene alluvium at this location is expected to contain some cobbles in a matrix of coarse gravelly sands overlain by silty and clayey sands. The uppermost bedrock formation in the area is the Arapahoe Formation.

The borehole will be drilled to the top of the alluvium-bedrock contact. The well will be completed in the alluvium, with the screened interval extending from within 2 m of the top of the water table to the top of the bedrock.

Proposed Well E-26

Location: 3 m (10 ft) east of the west section line and 30 m (100 ft) south of the north section line of Section 21 (T2S, R67W). The well will be located along East 96th Avenue, on the south side of the road between the I-76 Frontage Road (Old Brighton Road) and the south bound interchange for I-76.

Siting Rationale: 1) Contaminant plume delineation; and 2) Local hydrogeology.

Expected Site Conditions: The total depth of the well is anticipated to be 30 m (100 ft). The depth to water surface has been estimated to be 12 m (40 ft). Lithologic units present include the Broadway alluvium of upper Pleistocene Age, underlain by Lower Pleistocene alluvium. The Broadway alluvium is composed of gravel, sand, silt and clay which overlies earlier much thicker alluvial sequence consisting of about 25 m of sandy clays and clayey sands, grading to gravelly sands and gravels with cobbles with depth. Sediments are expected to be much coarser relative to the other wells. The uppermost bedrock formation in the area is the Arapahoe Formation.

The borehole will be drilled to the top of the alluvium-bedrock contact. The well will be completed in the alluvium, with the screened interval extending from within 3 m of the top of the water table to the top of the bedrock.

Proposed Well E-27

Location: 183 m (600 ft) west of the east section line and 30 m (100 ft) north of the south section line of Section 20 (T2S, R67W). The well will be located along East 88th Avenue on the north side of the road, west of the Burlington Ditch.

Siting Rationale: 1) Ground water quality beneath populated areas; 2) Contaminant plume delineation; and 3) Local hydrogeology.

Expected Site Conditions: The total depth of the well is anticipated to be 30.5 m (100 ft). The depth to the water surface has been estimated to be 8 m (26 ft). Lithologic units present include the Post-Piney Creek or Piney Creek alluvium overlying early Pleistocene alluvium. The sands, gravels, silts, and clays of the Piney Creek alluvium overlie a very

thick (23 m) alluvial sequence of coarse channel sediments. These consist of finer grained sands and silty, clayey sands grading into coarse gravelly sands, and gravels containing cobbles with depth. The uppermost bedrock in the area is the Denver Formation.

The borehole will be drilled to the top of the alluvium-bedrock contact. The well will be completed in the alluvium, with the screened interval extending from 2 m below the land surface to the top of the bedrock.

Proposed Well E-28

Location: 335 m (1,100 ft) east of the west section line and 762 m (2,500 ft) north of the south section line of Section 29 (T2S, R67W). The well will be located along Brighton Road, on the east side of the road, just south of East 84th Avenue.

Siting Rationale: 1) Ground water quality beneath populated areas; 2) Irrigation ditch and shallow ground water relationships; 3) Contaminant plume delineation; and 4) Local hydrogeology.

Expected Site Conditions: The total depth of the well is anticipated to be 12 m (40 ft). The depth to the water surface has been estimated to be 12 m (40 ft). Lithologic units present include the Post Piney Creek alluvium overlies Piney Creek alluvium. The overlying alluvium contains gravelly sands, silts and clay deposits which overlie channel deposits of gravels and coarse sands and silts. The uppermost bedrock formation in the area is the Denver Formation.

The borehole will be drilled to the top of the alluvium-bedrock contact. The well will be completed in the alluvium, with the screened interval extending from 3 m below the land surface to the top of the bedrock.

Proposed Well E-29

Location: 183 m (600 ft) west of the east section line and 274 m (900 ft) north of the south section line of Section 29 (T2S, R67W). The well will be located along Potomac Street, on the west side of the road.

Siting Rationale: 1) Ground water quality beneath populated areas; 2) Contaminant plume delineation; and 3) Local hydrogeology.

Expected Site Conditions: The total depth of the well is anticipated to be 30 m (100 ft). The depth to the water surface has been estimated to be 14 m (47 ft). Lithologic units present include Halocene-Pleistocene eolian sands which overlie early Pleistocene alluvium. The fine to medium grained eolian deposits overlie a thick sequence of alluvial sediments (25+ m) (82+ ft) consisting of fine grained sands interbedded with clayey sands and silty sands. These grade into coarse, gravelly sands, and gravels with cobbles at depth. There is a good possibility of cobbles being present near the base of the drill hole which may pose a problem in drilling. The uppermost bedrock formation in the area is the Denver Formation.

The borehole will be drilled to the top of the alluvium-bedrock contact. The well will be completed in the alluvium, with the screened interval extending from 3 m below the land surface to the top of the bedrock.

Proposed Well E-30

Location: On the east section line, 823 m (2,700 ft) north of the south section line of Section 8 (T2S, R67W). The well will be located along Buckley Road, across from the trailer park, and south of First Creek where First Creek crosses the eastern boundary of RMA.

Siting Rationale: 1) Background ground water quality; and 2) Local hydrogeology.

Expected Site Conditions: The total depth of the well is anticipated to be 6 m (20 ft). The water surface is very shallow at this location, being near the ground surface. Lithologic units present include eolian sand derived from the alluvium of major streams which is underlain by alluvium. Alluvium between bedrock and the surface sand deposits is gravelly coarse grained sands containing silt and clay layers. The uppermost bedrock formation in the area is the Denver Formation.

The borehole will be drilled to the top of the alluvium-bedrock contact. The well will be completed in the alluvium, with the screened interval extending from 1 m below the land surface to the top of the bedrock.

3.2.2 WELL LOCATION

The exact location of each monitoring well will depend on access and the location of overhead and buried utility lines. The extents of highway and railroad right-of-ways and easements, has been defined and listed in Table 3.2-1. Highway right-of-way information was obtained from the State of Colorado Department of Highways and the Adams County Highway Department. A list of adjacent landowners was prepared (Table 3.2-2) to assist in obtaining limited site access during drilling. This information was obtained from the Adams County Assessor's Office records.

Table 3.2-3 was prepared to assist in identify any hazardous situations which may exist due to overhead power lines telephone lines, etc. at each well site. The following utilities and gas line companies will be contacted during installation of the monitoring wells.

- o Union Rural Electric Association;
- o Public Service Company of Colorado;
- o Mountain Bell, Adams City Office;
- o South Adams County Water and Sanitation District; and
- o Public Utility Commission.

3.2.3 REQUIRED PERMITS AND UTILITY COMPANY COORDINATION

ESE will be responsible for securing and complying with any documentation or drilling permits required by agencies and regulations regarding the submission of well logs, samples, etc. However, COE will be responsible for obtaining right-of-way permits for each well site and ESE will be responsible for additional permits as required by the Colorado State Engineers Office (CSEO), etc. ESE will immediately, upon identification, notify USATHAMA by telephone in the event of any discrepancy between contractual and state or local requirements. ESE will establish and maintain contacts with all utility companies which may have service lines adjacent to the proposed monitoring wells.

Table 3.2-1. Land Ownership at Proposed Well Locations

Well Number	Ownership of Right-of-Way
E-1	Union Pacific Railroad
E-2	Adams County
E-3	Adams County
E-4	Adams County
E-5	Adams County
E-6	State of Colorado
E-7	Adams County
E-8	Adams County
E-9	Adams County
E-10	Burlington Northern Railroad
E-11	Burlington Northern Railroad
E-12	Adams County
E-13	Adams County
E-14	State of Colorado
E-15	Adams County
E-16	Adams County
E-17	Adams County
E-18	Union Pacific Railroad
E-19	Adams County
E-20	Adams County
E-21	State of Colorado
E-22	Adams County
E-23	Adams County
E-24	State of Colorado
E-25	State of Colorado
E-26	State of Colorado
E-27	Adams County
E-28	Adams County
E-29	Adams County
E-30	Adams County

Table 3.2-2. List of Property Owners Adjacent to Proposed Well
Drilling Sites (Page 1 of 3)

Well Number	Owner
E-1	Shelter D.G. Products (Digorgio) One Maritime Plaza San Francisco, California
E-2	Patricia & Johnie Vaughn 12650 Tucson St. Henderson, Colorado 80640
E-3	Potomac Farms Ltd 14991 E. Hampden, #380 Aurora, Colorado
E-4	Glen P. Murray, Trustee Louise Murray, Trustee Rt 3 - Box 177 Brighton, Colorado
E-5	Richard C. Frost Geraldine H. Frost Box 23 Henderson, Colorado 80640
E-6	Daniel L. Slanovich Gus J. Slanovich 1590 Bryant St. Denver, Colorado
E-7, E-8	Antonio Palizzi Jr. Rt. 1, Box 302 Brighton, Colorado
E-9	On Arsenal
E-10	MJP Services 10150 E. Hiway 2 Commerce City, Colorado
E-11	Charles Hickey Michael Hickey 3240 Jay St. Wheatridge, Colorado
E-12	Pioneer Steel & Tube Distributors, Inc. 9520 E. 104th Avenue Henderson, Colorado 80640

Table 3.2-2. List of Property Owners Adjacent to Proposed Well
Drilling Sites (Page 2 of 3)

Well Number	Owner
E-13	Mollie Heinze Dave Heinze 10131 E. 96th Avenue Henderson, Colorado 80640
E-14	Charles Hickey Michael Hickey 3240 Jay St. Wheatridge, Colorado
E-15	Timothy McManus 1515 Arapahoe St. - #1600 Aurora, Colorado
E-16	Shelter D.G. Products (Digorgio) One Maritime Plaza San Francisco, California or Edward Jersin John Yelenick 2 S. Dahlia St. Denver, Colorado
E-17	Hazeltine Company 1515 Arapahoe St. - #1600 Denver, Colorado
E-18	Glen P. Murray, Trustee Louise Murray, Trustee Rt 3 - Box 177 Brighton, Colorado
E-19	Robert W. Derr et al P. O. Box 27 Henderson, Colorado 80640
E-20	Adams County
E-21	Northside: Myer J. Schaffner 11405 Quivas Way Westminster, Colorado 80234

Table 3.2-2. List of Property Owners Adjacent to Proposed Well
Drilling Sites (Page 3 of 3)

Well Number	Owner
	Southside: Joseph M. Monson William E. Monson P.O. Box 56 Greeley, Colorado 80632 (Land farmed by Priola: 104th & Havana)
E-22	George Fagler Dolly M. Fagler 800 Pennsylvania St. - #802 Denver, Colorado Resident: Wilhelm 11651 Brighton Rd. Henderson, Colorado
E-23	Walt Flanagan & Co. 373 W. Evans Denver, Colorado
E-24	MJP Services 10150 E. Hiway 2 Commerce City, Colorado
E-25	Brannan Sand & Gravel Co. and Western Paving Construction Co. 4800 Brighton Blvd. Denver, Colorado
E-26	State of Colorado Highway Right of Way
E-27	Charlene Faden Mantel Jane Faden Hubbell 4275 S. Forest Ct. Englewood, Colorado
E-28	The Archdiocese of Denver c/o Bill McCook 200 Josephine St Denver, Colorado
E-29	School District 14 Pontiac St.

Table 3.2-3. Listing of Buried Utility Lines Adjacent to Drilling Sites

Well Number	Water	Sewer	Public Service Gas	Service Electric	U.R.E.A. Electric	Phone Trunk Lines	Gas Lines
E-1	P	N	N	N	E	N	N
E-2	N	N	N	N	N	N	N
E-3	N	N	N	N	E	N	N
E-4	P	P	N	N	E	E	N
E-5	N	N	N	N	N	N	N
E-6	P	N	N	N	N	N	N
E-7	N	N	N	N	E	E	N
E-8	N	N	N	N	E	E	N
E-9	N	N	N	N	E	E	N
E-10	N	N	N	N	N	N	N
E-11	N	N	N	N	N	E	N
E-12	P	P	N	N	E	N	E
E-13	P	E	N	N	E	N	N
E-14	N	N	N	N	N	E	N
E-15	E	N	N	N	E	E	E
E-16	E	E	N	N	E	N	N
E-17	E	E	E	N	E	E	E
E-18	N	N	N	N	N	E	N
E-19	E	N	N	N	E	E	N
E-20	N	N	N	N	N	N	N
E-21	P	E	E	N	E	E	N
E-22	N	N	E	N	N	N	N
E-23	P	P	E	N	P	N	N
E-24	N	N	N	N	N	E	N
E-25	N	N	N	N	N	N	N
E-26	P	P	N	N	P	E	N
E-27	P	N	N	N	N	E	N
E-28	E	E	N	N	E	E	N
E-29	E	P	N	N	P	E	N
E-30			E	N			

E = Lines exist near the drill site.

P = Line proposed for placement near the drill site.

N = No existing or proposed lines are near the drill site.

U.R.E.A. = Union Rural Electric Association.

3.3 SURFACE GEOPHYSICS

The applicability of surface geophysical techniques as an aid to siting monitor wells in zones of ground water contamination has been reviewed and is considered not to be as useful as the information to be gained from the potable water monitoring program. Such techniques are, therefore, not included in this Geotechnical Program.

3.4 INITIATION OF FIELD PROGRAM

The primary purpose of the Offpost Contamination Assessment Program is to evaluate offsite impacts from possible migrating contaminants.

Therefore, several precautions must be taken to minimize the possibility of cross-contamination between field sites during soil boring, drilling and well construction operations.

The steam cleaning of all drilling equipment to include rigs, water tanks (inside and out), augers, drill casings, rods, samplers, tools, recirculation tank, etc., will be completed prior to project site arrival, following by washing with approved water between boring/well sites. Prior to use, all casings, augers, and recirculation and water tanks, etc., will be devoid both inside and out of any asphaltic, bituminous, or other encrusting or coating materials, grease, grout, soil, etc. Paint, applied by the equipment manufacturer, may not be removed from drilling equipment.

The source of water to be used in drilling, grouting, sealing, purging, well installation or equipment washing will come from the approved water sources as agreed upon by the Contracting Officer. The approved water source to be used in the offpost RMA decontamination will be from Brighton City well #17. This well is located north of the project area. The well is a Brighton City municipal supply well which was sampled by ESE and Tri-County District Health Department.

Well contamination will also be controlled by introducing into the borehole only approved contaminant free material, including drill stem lubricants, bentonite and sand.

Only Teflon® tape or USATHAMA approved lubricants such as petroleum jelly will be used on the threads of downhole drilling equipment.

Air systems, including bottled gas, will not be used for drilling, well installation, well development, presample purging, or sampling unless specified herein. However, when an alternative drilling method using air is required, information regarding the alternative method will include:

- o Situation prompting action;
- o Recommendation;
- o The effect of the use of air on ground water and soil chemical analyses; and
- o Alternatives with cost sampling or increases, as appropriate.

The above items will be quantified, costed and will incorporate the appropriate criteria discussed below.

In general, air system plans will:

- o Specify the type of air compressor and lubricating oil and require a pint sample of type and lot to be retained for characterization in the event of future problems;
- o Require an air line oil filter and that filter be changed per manufacturer's recommendation during operation with a log kept of associated maintenance. More frequent changes will be made if oil is visibly detected in the filtered air;
- o Prohibit the use of any additive except approved water for dust control and cuttings removal; and
- o Detail the use of any downhole hammer/bit with emphasis upon those procedures to be taken to preclude residual ground water sample contamination caused by the lubrication of the downhole equipment.

Air usage will be fully described in the log or associated geotechnical report to include equipment description(s), manufacturer(s), model(s), air pressures used, frequency of oil filter change, and evaluation of the system performance, both design and actual.

Bentonite is the only drilling fluid additive that will be used. No organic drilling fluids or additives will be used. The use of any

bentonite will be approved by the Contracting Officer prior to the arrival onsite of the drilling equipment (rigs). This includes bentonites (powders, pellets, etc.) intended for drilling mud, grout seals, etc. The following data will be submitted in writing through USATHAMA to the Contracting Officer as part of the approval request:

- o Brand name(s);
- o Manufacturer(s);
- o Manufacturer's addresses(ee) and telephone number(s);
- o Product description(s) from package label(s)/manufacturer's brochure(s); and
- o Intended use(s) for this project.

Six working days will be allowed from the time of receipt by USATHAMA for request evaluation and recommendation.

When drilling fluid is used, fluid losses, quantities lost, and the intervals over which they occur will be recorded. The drilling equipment used will be described generally on each log, including such information as rod size, bit type, pump type, rig manufacturer, and model.

If antifreeze is added to any pump, hose, etc., in an area in contact with drilling fluid, this antifreeze will be completely purged prior to the equipment's use in drilling, mud mixing, or any other part of the overall drilling operation. Only antifreeze without rust inhibitors and/or sealants will be used. ESE will not on the borehole log the dates, reasons, quantities, and brand names of antifreeze usage.

Surface runoff; e.g., precipitation, wasted or spilled drilling fluid, and miscellaneous spills and leaks, will not enter any borehole or well either during or after drilling/well construction. To help preclude this, the use of starter casing, recirculation tanks, berms around the borehole, and/or surface bentonite packs will be used as appropriate.

Accurate record will be kept of water introduced into well during development. When water is used in diluting drilling fluid in a monitoring well during development, five-times the volume of water used will be added to the volume of water which must be purged from the well during development.

Tracers or dyes will not be used or otherwise introduced into borings, wells, grout, backfill, ground water, or surface water.

A geologist will be present and responsible at each monitoring drill rig for the logging of samples, monitoring of drilling operations, recording of water losses/gains and ground water data, preparing the boring logs and well diagrams, and recording the well installation procedures of that rig. Each geologist will be responsible for only one operating rig. Each geologist will have onsite, as a minimum: his/her own copy of the geotechnical portion of the statement of work, these "Geotechnical Requirements", and the approved Safety Plan. Each geologist will also have onsite his/her own 10X hand lens; a weighted steel tape, heavy and long enough to sound all depths and small enough to be readily fit within the annulus between the well and drill casing; an electrical water level measuring device, Muncel soil color chart; GSA Rock Color Chart; photographic color chart; field forms; and sample bottles, etc.

The geologist will wear safety glasses, hard hat, and steel-toed shoes when working in the vicinity of the drill rig. The geologist will wear reflective safety vest when drilling is conducted along a road right-of-way.

3.5 SOIL SAMPLING

ESE will be responsible for securing and complying with any documentation or drilling permits required by agencies and any regulations regarding the submission of well logs, samples, etc. However, COE will be responsible for obtaining right-of-way permits for each well site and ESE will be responsible for additional permits as required by the Colorado State Engineers Office (CEO), etc. ESE will immediately, upon identification, notify USATHAMA by telephone in the event of any discrepancy between contractual and state or local requirements.

Soil borings at each of the monitor well locations will be completed as the initial step in the drilling operation. The ESE Project Geologist will maintain regular contact with USATHAMA during the drilling program and will inform USATHAMA in the event that unique geohydrologic

conditions dictate variation of the plans presented in this Technical Plan.

3.5.1 BOREHOLE DESCRIPTION

Each borehole will be fully described on a borehole log (Figure 3.5-1) as it is being drilled. Only the original borehole log will be submitted from the field to fulfill the above requirement. Transcription of the log from a field notebook to log form will not be permitted. This technique reduces offsite work hours for the geologist, lessens the chance for errors of manual copying, and allows the completed document to be field-reviewed closer to the time of drilling. Normal day-to-day activities will be recorded by the geologist on the Record of Activities at Drill Site form as shown in Figure 3.5-2.

Each original borehole log will be submitted directly from the field to the Contracting Officer's designated office within 3 working days after the borehole is completed. In those cases where a monitor well is to be installed both the log for that borehole and the installation diagram must be submitted within 3 working days after well completion. Submission will not be delayed while awaiting the installation of protective casing.

Data included in the logs are listed here. These requirements and procedures conform to USATHAMA's Geotechnical Requirements (USATHAMA, 1983).

1. Depths will be recorded in feet and fractions thereof (tenths of feet). Metric measurements only will be entered on the data entry forms.
2. Soil descriptions, in accordance with the Unified Soil Classification System, (equivalent to American Society for Testing and Materials (ASTM) D 2487-69) will be prepared in the field by the Field Geologist.
3. Soil samples will be fully described on the log in the field by the Field Geologist. For split-spoon and Shelley tube samples, the description will include:

**ENVIRONMENTAL SCIENCE
AND ENGINEERING, INC.**

FIELD LOG OF BORING

SITE TYPE SITE ID
 BORE

SHEET _____ OF _____

PROJECT NAME AND LOCATION		PROJECT NUMBER		ELEVATION AND DATUM				
DRILLING COMPANY		DRILLER		DATE AND TIME STARTED		DATE AND TIME COMPLETED		
DRILLING EQUIPMENT: METHOD				COMPLETION DEPTH		TOTAL NO. OF SAMPLES		
SIZE AND TYPE OF BIT				NUMBER OF SAMPLES	BULK	SS	DRIVE	PITCHER
DRILLING FLUID				WATER LEVEL FIRST		AFTER _____ HOURS		
SAMPLER HAMMER TYPE		DRIVING WT.		DROP		HYDROGEOLOGIST/DATE		CHECKED BY/DATE

DEPTH- FEET	SAMPLES					DESCRIPTION	WELL COMPLETION
	TYPE AND NUMBER	INTERVAL	RECOVERY	BLOW COUNT	USCS SYMBOL		
2							
1							
0							
1							
2							
3							
4							
5							
6							
7							
8							
9							
10							

Figure 3.5-1
 FIELD LOG OF BORING
 (PAGE 1 OF 2)

Prepared for:
 U.S. Army Toxic and Hazardous
 Materials Agency
 Aberdeen Proving Ground, Maryland

<u>Parameter</u>	<u>Example</u>
Classification	Sandy Clay
Unified Soil Classification	CL
Secondary Components and Estimated Percentages	Sand: 25% (Fine Sand 5%, Coarse Sand 20%)
Color (using Munsell Soil or Geological Society of America (GSA) Rock Color Chart), give both narrative and numerical description and note which chart used.	Gray: 7.5 YR 5/0 Munsell
Plasticity	Low Plasticity
Consistency (cohesive soil)	Stiff
Density (non-cohesive soil)	Loose
Sorting	Well to Poor
Moisture Content, (do not express as a percentage unless a lab value)	Dry, moist, wet, etc.
Texture/Fabric/Bedding and Orientation	No apparent bedding; numerous vertical, iron-stained, tight fractures
Depositional Environment and Formation, if named	Broadway alluvium, eolian sands

4. In the field, visual numeric estimates shall be made of secondary soil constituents; e.g., "silty sand with 20 percent fines" or "sandy gravel with 40 percent sand". If such terms as "trace", "some", "several", etc., are used, their quantitative meaning will be defined on each log or within a general legend.
5. The length of the sample recovery will be recorded.
6. Blow counts, hammer weight and length of fall for split-spoon and Shelley tube samples will be recorded.
7. Each rock core shall be visually described for the following parameters:

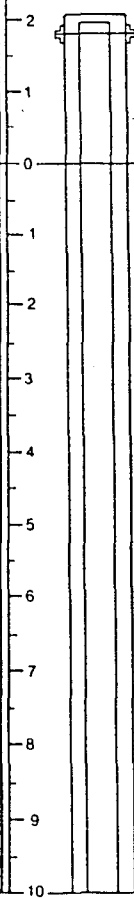
<u>Parameter</u>	<u>Example</u>
Classification	Limestone, Sandstone, Granite
Lithologic Characteristics	Shaly, Calcareous, Siliceous, Micaceous
Bedding/Banding Characteristics	Laminated, Thin Bedded, Massive, Cross Bedded, Foliated
Color (using Munsell Soil or GSA Rock Color Chart), give both narrative and numerical description and note which chart was used	Mod. Brown: 5 YR 3/4 GSA
Hardness	Soft, Very Hard
Degree of Cementation	Poorly Cemented, Well Cemented
Texture	Dense, Fine-, Medium-, Coarse-grained, Glassy, Porphyritic, Crystalline
Structure and Orientation	Horizontal Bedding, Dipping Beds at 30°, Highly Fractured, Open Vertical Joints, Healed 30° Faults, Slickensides at 45°, Fissile
Degree of Weathering	Unweathered, Badly Weathered
Solution or Void Conditions	Solid, Cavernous, Vuggy with partial infilling by clay
Primary and Secondary Permeability, include estimates and rationale	Low Primary: Well Cemented High Secondary: Several Open Joints
Lost Core, interval and reason for loss	50-51 ft, Noncemented Sandstone Likely

8. Rock cores shall be stored in covered wooden boxes in such a manner as to preserve their relative position by depth. Intervals of lost core shall be noted in the core sequence with annotated wooden blocks. Boxes shall be marked inside and out to provide borehole number, cored interval, and box number in

cases of multiple boxes. The weight of each fully loaded box shall not exceed 75-pounds (1b). No geotechnical data shall appear on or within the box that is not already specified on the borehole log.

The core within each completed box shall be photographed after the core surface has been cleaned/peeled and wetted. Photos shall be taken using color film (ASA as appropriate), 35mm camera, 55mm (minimum) lens, light meter, with one box per frame. Each photo shall be in sharp focus and contain both a legible scale in feet and tenths of feet (or centimeters) and a photographic color chart for color comparison. The core shall be oriented so that the top of the core is at the top of the photo. One set of 3 x 5-inch glossy color prints plus all negatives shall be sent to USATHAMA via registered mail within 2-weeks of the last coring. Each photo shall be annotated on the back as to the bore/well designation, box number, and cored depths denoted in the photograph. The photos shall be used to enhance the interpretation of core sketches and corresponding narrative descriptions.

At a minimum, the estimated number of boxes required for each borehole will be at the site prior to the initiation of coring procedures. All cores will be kept from freezing for a minimum of 12 months and/or until all analyses have been conducted. A heated storage secured area has been approved and is located on the RMA.

9. Representative soil samples from each sampler will be placed in half or one-pint wide-mouth amber glass bottles which have been placed in individual compartments in cardboard boxes. A single box shall not contain more than 24 one-pint jars or 48 half-pint jars. The jars will have airtight, screw type lids and will be thoroughly cleaned according to procedures outlined in Section 3.2. Sample containers will be marked to indicate sampling date, time and location. Additional samples taken from Shelby tube samplers, will be collected in large plastic bags for sieve analysis and permeability measurements.

10. The depth of first encountered free water will be measured and recorded along with the method of determination; e.g., "11.5-m from direct measurement after drilling to 12-m"; or "12-m from direct measurement in 18-m hole when boring left overnight, hole dry at end of previous shift"; or "7.6-m based on saturated soil sample while sampling 7- to 8-m". Allow the first encountered water to partially stabilize for 5 to 10 minutes. This secondary level and time between measurements will be recorded before proceeding. Also describe any other distinct water bearing zones and measured water levels.
11. When drilling fluid is used, quantitative records will be taken on fluid losses and/or gains and the interval over which they occur. Fluid losses will be adjusted for spillage and intentional wasting (e.g., recirculation tank cleaning) to more accurately estimate the amount of fluid lost to the subsurface environment. The deepest depth of drilling or sampling will be noted and recorded as the total depth.
12. The drilling equipment used will be generally described either on each log or in a general legend. Such information as rod size, bit type, pump type, rig manufacturer and model will be recorded.
13. The drilling sequence will be recorded on each log: e.g.,
 1. Open hole with 20-cm auger to 2.7-m.
 2. Set 20-cm casing to 3-m.
 3. Cleaned out and advanced hole with 20-cm roller bit to 5-m (cleanwater, no water loss).
 4. Drove standard sampler to 5-m.
 5. Advanced with 20-cm roller bit to 10-m, 15-gallon (gal) water loss.
 6. Drove standard sampler to 10-m.
 7. Hole heaved to 6-m.
 8. Mixed 25-lb of ABC bentonite in 100-gal of water for hole stabilization and advanced with 20-cm roller bit to 14-m, etc.
14. Record all special problems and their resolution on the log; e.g., hole squeezing, recurring problems at a particular depth,

grout in wells, excessive grout takes, drilling fluid losses, unrecovered tools in hole, lost casings and screens, etc. The dates for the start and completion of boreholes shall also be recorded on the log along with notation by depth for drill crew shifts and individual days.

15. Various soils and individual lithologic boundaries will be noted on the log by depth. When depths are estimated, the estimated range will be noted.

3.5.2 DRILLING TECHNIQUES

To ensure plumbness of the borehole, the drill rig will be carefully leveled prior to commencement of the drilling. When a borehole is completed, the ESE Site Geologist will visually inspect the hole to ensure plumbness and cleanliness. The drilling will proceed in an efficient and controlled manner to eliminate wobble and chatter in the drill stem.

Hollow-stem augers [6.25-in inside diameter (ID) and 10.25-in outside diameter (OD)] and split spoon or Shelby tube samplers will be used to drill and sample the soil. A Fox Drilling, Inc. (FDI) rig owned by FDI will be utilized. Soil samples will be obtained continuously from 0- to 3-m and thereafter at 1.5-m intervals or at each major lithologic change until bedrock refusal. The solid samples will be collected during split-barrel or Shelby tube sampling. Weight of hammer, diameter of sampler, number of blows, drop distance, penetration distance, and length of sample recovered will be recorded. If saturated materials are located in the borehole, the hole will be completed as a monitoring well before the drill rig leaves the site. No boring will be left open for more than 24-hours without installation of a casing-screen assembly. If abandoned, boreholes will be grouted as required by the USATHAMA Geotechnical Requirements, and the rules and regulations of the Colorado statues governing construction of water wells and installation of pump equipment.

For the Denver (deep) well, continuous cores will be obtained to assist in the generation of detailed borehole sample descriptions. The cores will consist of representative samples of most of the rock types expected

to be encountered in the offpost area. In this deep well, rotary drilling utilizing conductor casing may be required to keep the hole open.

The cores will serve as a model to enable the geologist to calibrate the types of response on downhole geophysical logs against known rock types or zones. The downhole geophysical data will be used to infer subsurface characteristics in the wells at which no core is taken.

Should any of the drilling and sampling methods prove infeasible under local conditions, the site geologist along with the task manager immediately will contact USATHAMA. This contact will be to discuss alternative methods and gain approval before proceeding.

3.6 BOREHOLE GEOPHYSICS

Borehole geophysics has been widely used in the exploration for ground water during the last 20 years, and more recently, in ground water contamination studies. Correlation vertically within boreholes, correlation horizontally between boreholes estimation of formation lithologies, and the quantitative measurement of porosity, permeability, and water quality are the prime ground water uses of borehole geophysics. Geophysical logging units available to the Field Geologist are designed for shallow small-diameter holes, saturated with fresh water. The equipment is portable and can log up to 300-m holes. All tools fit in 7.6-cm holes, and many fit in 5-cm holes.

After completion to total depth, the borehole will be geophysically logged using at a minimum natural gamma ray and resistivity. The geophysical logs provide valuable information on subsurface clay content (natural gamma). Natural gamma radiation emanates in measurable doses from ^{40}K decay. Therefore, clay minerals which contain high concentrations of potassium yield a relatively high gamma response. If other detrital minerals in a stratigraphic sequence originate from the same source, then deviation in gamma response from various soil factors is not as distinct. However, under most circumstances, measurement of

natural gamma is a valuable tool for distinguishing between silts and clay and will aid in correlating strata across the study area.

Downhole resistance or resistivity logs provide an excellent tool for stratigraphic correlations and porosity determinations. Resistivity is a characteristic of a material as is the materials color, taste, density, etc. Resistance of a materials, however, is determined by its size, shape, and resistivity. In general however, both measurements reflect the ability of a substance to resist a flow of electrical current.

3.7 ABANDONMENT

The abandonment of any boreholes or wells will be approved by the Contracting Officer prior to any casing removal, sealing, or backfilling. Abandonment requests will be submitted by telephone through USATHAMA to the Contracting Officer with the following data:

1. Designation of borehole or monitor well in question;
2. Current status (depth, contents of hole, stratigraphy, water level, etc.);
3. Reason for abandonment;
4. Recommendation.

Four consecutive hours will be allowed from the time of receipt by USATHAMA for a request of evaluation and recommendation. Frequently, resolution is made within minutes. Infrequent circumstances may preclude a 4-hour resolution. A written follow-up request shall be made by ESE within 5 working days of the telephone request. This document shall be forwarded through USATHAMA to the Contracting Officer.

Once approved, the borehole or monitor well to be abandoned shall be sealed by grouting from the bottom of the bore/well to ground surface. This shall be conducted by placing a grout pipe to the bottom of the bore/well (i.e., to the maximum depth drilled/bottom of well screen) and pumping grout through the grout pipe until undiluted grout flows from the bore/well at ground surface. Any open or ungrouted portion of the annular space between the well casing and borehole will also be grouted in the same manner. After grout placement, the grout pipe augers and well casing will be removed. When conditions permit, the grout placement

and casing removal may be completed incrementally so as to constantly maintain 3-m of grout within the borehole.

After 24 hours, the contractor will check the abandoned site for grout settlement. That day, any settlement depression shall be filled with grout and rechecked 24 hours later. This process shall be repeated until firm grout remains at ground surface.

For each abandoned borehole or monitor well, a record will be prepared to include the following:

1. Borehole/well designation.
2. Location with respect to the replacement borehole or well (e.g., 6-m north and 6-m west of Well 14).
3. Open depth prior to grouting and depth to which grout pipe was placed. This includes the depth of open hole, open depth to the bottom of the well, and the open depth in the well-borehole annulus.
4. Casing left in hole by depth, composition, and size.
5. Copy of borehole log.
6. Diagram of abandoned well.
7. Drilled and sampled depth prior to decision to abandon site.
8. Items left in hole by depth, description, and composition.
9. Description and total quantity of grout used initially.
10. Description and daily quantities of grout used to compensate for settlement.
11. Date of grouting.
12. Water or mud level (specify) prior to grouting and date measured.
13. Remaining casing above ground surface: height above ground, size, and composition.

All depths/heights will be reported from ground surface.

Grout will be composed by weight of 10 parts portland cement to one-half part bentonite, with a maximum of 10-gal of approved water per 94-lb bag of cement. Bentonite will be added after mixing of the cement and water.

Information concerning the bentonite will be submitted to USATHAMA for approval, as specified by the Geotechnical Requirements (USATHAMA, 1983).

The original record shall be submitted to the Contracting Officer's designate office 3 days after abandonment is completed. A record of abandonment is presented in Figure 3.7-1).

Ideally, replacement wells/borings will be offset at least 6-m from any abandoned site in a presumed up- or cross-gradient ground water direction. Site specific conditions may necessitate variation to this placement.

3.8 WELL INSTALLATION

Monitor wells will be constructed at the study area to investigate both near-surface stratigraphy and ground water characteristics. The wells will be constructed to maximize the probability of obtaining a representative sample of ground water.

The installation of each monitor well will begin within 24 consecutive hours of borehole completion for uncased or partially cased holes. Installation will begin within 48 consecutive hours in fully cased holes. Once installation has begun, no breaks in the installation process will be made until the well has been grouted and drill casing removed. Exceptions will be requested in writing by the ESE to the Contracting Officer through USATHAMA for consideration prior to drilling. Data to be include in this request are:

1. Well(s) in question.
2. Circumstances.
3. Recommendations and alternatives.

Three working days will be allowed from the time of receipt by USATHAMA for request evaluation and recommendation.

In cases of unscheduled delays such as personal injury, equipment breakdowns, sudden inclement weather, or scheduled delays such as borehole geophysics, no advance approval of delayed well installation is needed. In those cases, installation will be resumed as soon as practical. In cases where a partially cased hole into bedrock is to be somewhat developed prior to well insertion the well installation will begin within 12 consecutive hours after this initial development.

Once begun, well installation shall not be interrupted due to the end of the contractor's/driller's work shift, darkness, weekend, or holiday. The ESE Site Geologist and the contractor will ensure that all materials for a given well are available and onsite prior to drilling that well.

Well depths and screen lengths for each of the monitor wells will be determined after inspection and/or assessment of all the geotechnical data obtained from the drilling and logging program. The Site Geologist will maintain regular contact with USATHAMA during the drilling program and make recommendations for well placement to USATHAMA in the event that unique geohydrologic conditions dictate variation of the plans presented in this report.

3.8.1 WELL SCREENS, CASINGS AND FITTINGS

The specific locations and/or depths and screened intervals will be refined and minor changes made as necessary based on the subsurface conditions observed during drilling. The wells in the alluvium will be screened throughout the water column above the top of bedrock. Denver wells will be screened across the first transmissive stratum encountered. The assumed depths of the alluvial and Denver wells are 15-m (50-ft) and 30-m (100-ft), respectively.

The well screens will only consist of PVC casings. All well screens will be commercially fabricated, 20 (0.020-in) slot, and have an inside diameter of 3.9-in. PVC screens will be used with Schedule 40 PVC well casing. The PVC casing will be located above the water table. No fitting (coupling) will restrict the inside diameter of the joined casing and/or screen. All screens, casings and fittings will be new. All well

screens and well casings will be free of foreign matter (e.g., adhesive tape, labels, soil, grease, etc.) and washed with approved water prior to use. Washed screens and casings will be stored in plastic sheeting prior to insertion. Well screens will be placed no more than 0.9-m (3-ft) above the bottom of the drilled borehole. All screen bottoms will be securely fitted with a PVC cap. This cap/plug will be within 0.15-m (6-in) of the open portion of the screen.

Joints within the casing and screen will be threaded. Heat welded joints, gaskets, solvent welds, or slip couplings shall not be used. Figures 3.8-1 and 3.8-2 depict schematic well construction.

When a borehole, made with or without the use of drilling fluid, contains an excessively thick, particulate-laden fluid which would preclude or practically hinder contractural well installation, the bore may be purged with approved water. This purging is intended to remove or dilute the thick fluid and thus allow the proper placement of well, granular backfill and seal. Fluid losses in this operation will be initially recorded on the well diagram or borehole log.

Well centralizers, when used, will be attached to the casing via stainless steel. Centralizers will not be attached to the well screen or to that part of the well casing exposed to granular backfill.

The tops of all well casings will be fitted with undersized plugs or oversized caps both of which shall be easily removed by hand.

3.8.2 GRANULAR BACKFILL

All granular backfill must be approved by the Contracting Officer prior to drilling. A one-pint representative sample of each proposed granular backfill (sand/gravel or filter pack) accompanied by the data below will be submitted by the contractor to the Contracting Officer through USATHAMA for consideration prior to drilling. Each sample will be described, in writing, in terms of:

1. Lithology.
2. Grain size distribution.

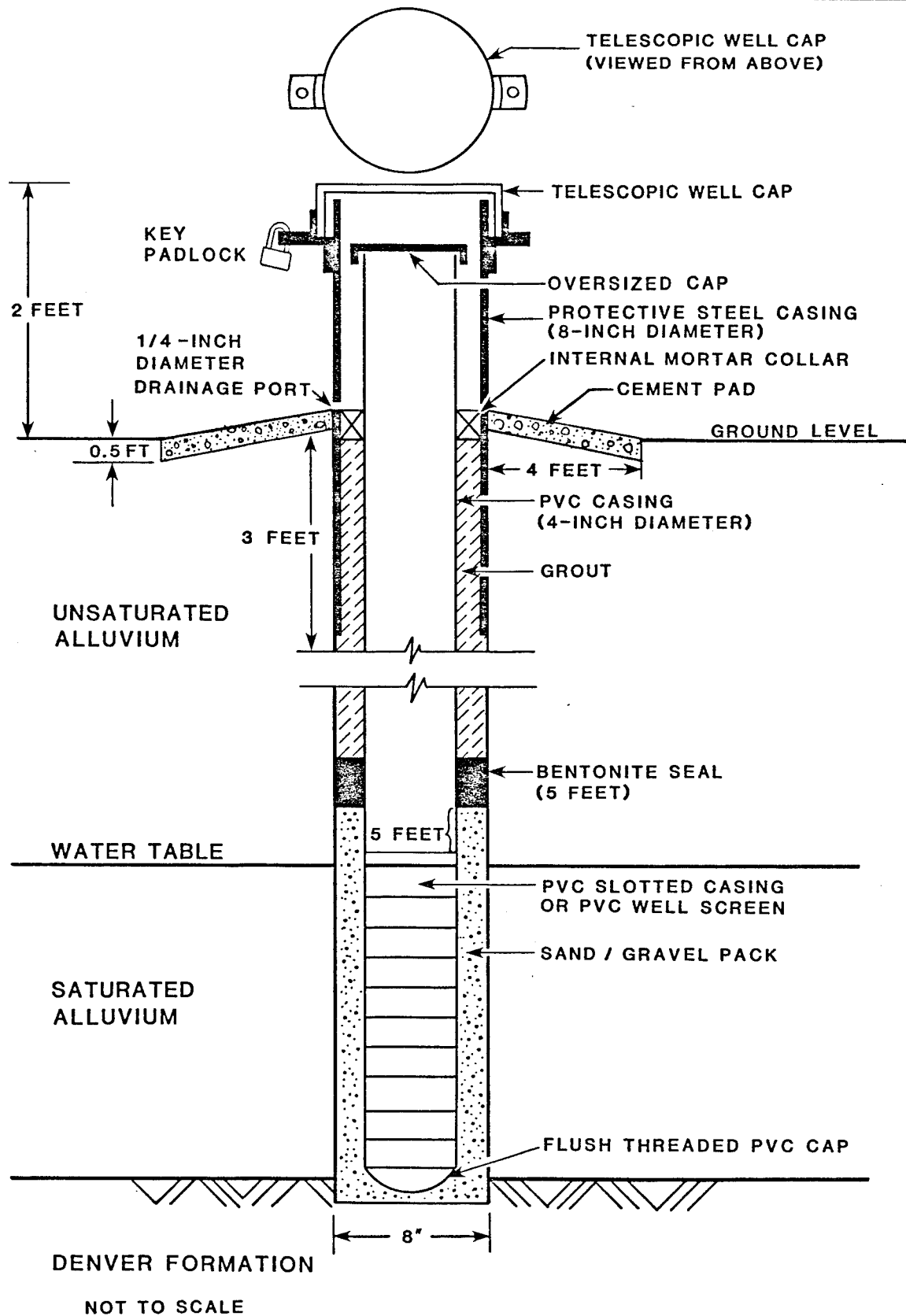
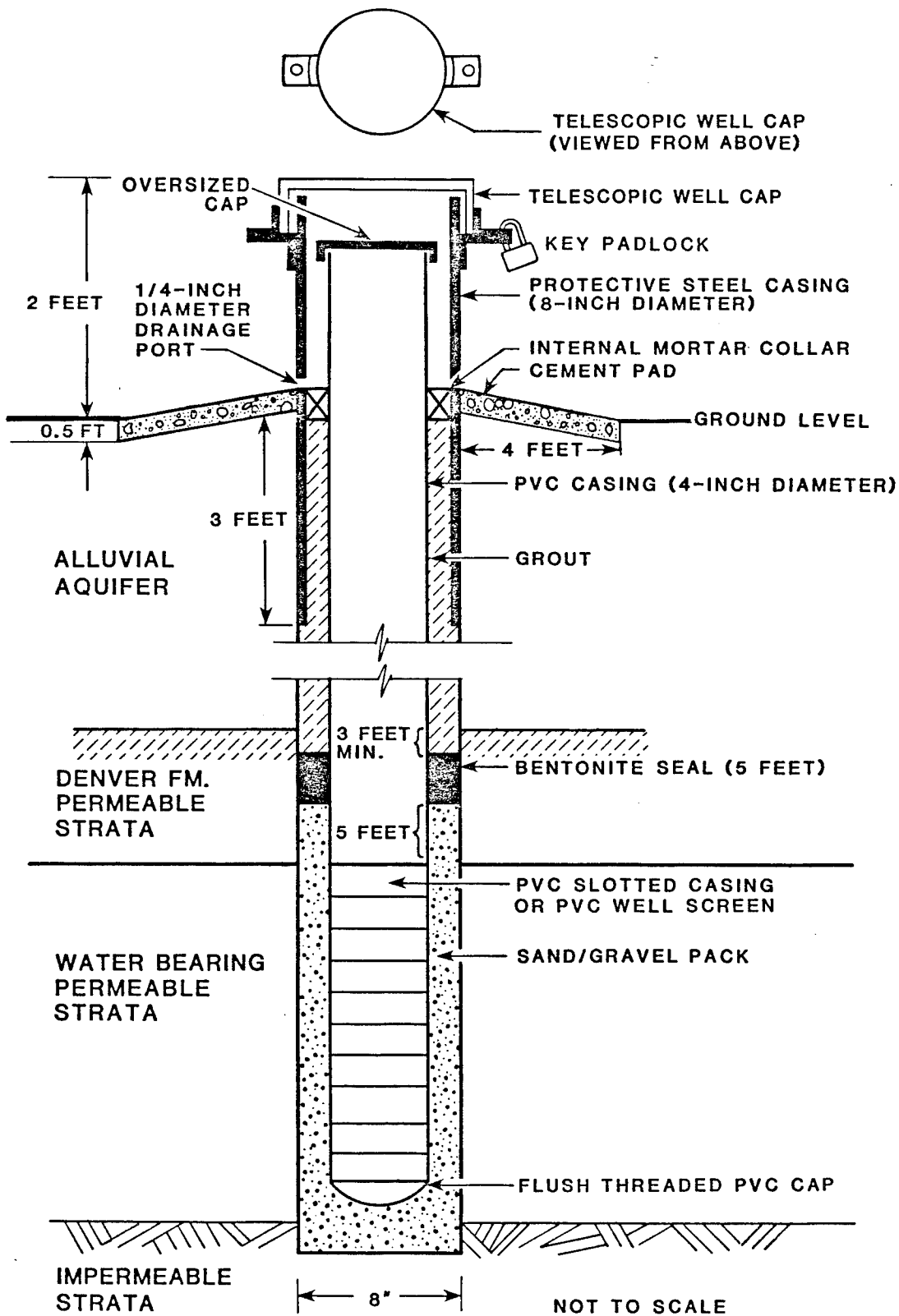

Figure 3.8-1
SHALLOW (ALLUVIAL) MONITOR WELL
CONSTRUCTION

Prepared for:
U.S. Army Toxic and Hazardous
Materials Agency
Aberdeen Proving Ground, Maryland



SOURCE: ESE, 1985

Figure 3.8-2
DEEP (DENVER FORMATION)
MONITOR WELL CONSTRUCTION

Prepared for:
U.S. Army Toxic and Hazardous
Materials Agency
Aberdeen Proving Ground, Maryland

3. Trade name, if any.
4. Source, both company from whom purchased and location of pit or quarry of origin.
5. Processing method; e.g., pit run, screened and unwashed, screened and washed with water from well/river/pond, etc.
6. Slot size of intended screen.

Eight working hours will be allowed for evaluation and recommendation once all of the above data are received by USATHAMA.

Granular backfill will be chemically and texturally clean (as seen through a 10X hand lens), inert, siliceous, and of appropriate size for the well screen and host environment.

The granular backfill will extend above the top of the screen by at least 2-m (6-ft) except in cases where the water table is close to the land surface.

3.8.3 BENTONITE SEAL

Bentonite seals will be composed of commercially available pellets. Pellet seals will be a minimum of 2-m (6-ft) thick as measured immediately after placement, without allowance for swelling. Slope Indicator Company bentonite pellets or their equivalent will be used after approval by USATHAMA.

Slurry seals will be used only as a last resort, as when the seal location is too far below water to allow for pellet or containerized-bentonite placement within a narrow well-borehole annulus. Slurry seals will have a thick, batter-like consistency with a placement thickness of 2-m (6-ft) maximum.

In wells designed to monitor bedrock, the bentonite seal will be located at least 0.9-m (3-ft) below the top of firm bedrock, as may be determined by drilling refusal. "Firm bedrock" refers to that portion of solid or relatively solid, moderately to unweathered bedrock where the frequency of loose and fractured rock is markedly less than in the overlying, highly weathered bedrock. The interval between the top of the bentonite

seal and the top of the highly weathered bedrock will be filled with grout.

3.8.4 GROUT SEAL

The gel-cement grout seal will fill the annulus from the top of the bentonite seal to the land surface. Grouting will be completed as a continuous operation in the presence of the ESE Field Geologist. The grout will be pumped into the annular space under pressure using a tremie pipe placed at the top of the bentonite seal to ensure a continuous grout seal. The protective casing will be sealed in the grout.

At 24-hour intervals following the completion of a borehole, a grouted borehole will be checked for settlement, and grout of approved composition will be added, if necessary, to attain pre-drilling surface contours.

Grout will be composed by weight of 10 parts portland cement to one-half part bentonite, with a maximum of 10-gal of approved water per 94-lb bag cement. Bentonite will be added after mixing of the cement and water. Information concerning the bentonite will be submitted to USATHAMA for approval, as specified by the Geotechnical Requirements (USATHAMA, 1983).

3.8.5 PROTECTIVE CASING

Protective casing will be installed around each monitor well within 24-hours of initial grout placement around the well. Requests for exceptions in usage, design, and timing of placement will be considered on a case-by-case basis by the Contracting Officer. Requests in writing will be made through USATHAMA prior to drilling. Included in the request are:

1. The well(s) involved;
2. Reason for request;
3. Cost savings;
4. Recommendation; and
5. Alternatives.

Six working days will be allowed for evaluation and recommendation after the request is received by USATHAMA.

All protective casing will be steam cleaned prior to placement, free of extraneous openings, devoid of any asphaltic, bituminous, encrusting, and/or coating materials (except the black paint or primer applied by the manufacturer).

Minimum elements of protection design include:

1. A 1.4-m (5-ft) minimum length of new, black iron/steel pipe extending about 0.76-m (2-ft) above ground surface and set in grout (see Figure 3.8-3).
2. A 20-cm protector pipe for 10.16-cm (4-in) wells.
3. A hinged cover or loose fitting telescoping cap to keep precipitation and runoff out of the casing.
4. All protective casing covers/caps secured to the casing by means of a padlock from the date of protective casing installation.
5. All padlocks at a given site (project area) open by the same key.
6. No more than 0.1-m (2.5-in) from the top of protective casing to the top of well casing.
7. The outside only of the protective casing, hinges (if present), and covers/caps painted fluorescent orange (with a paint brush, not aerosol can) after installation. Painting will be required to be completed and dry prior to development.
8. The painting of the well designation on the outside of the protective casing, using white paint and a brush. This identification shall be done after the casing is painted as described above. Painting will be required to be completed and dry prior to development.
9. The 0.7-m (2-ft) radial placement of 4 posts with 3-strand barbed wire as livestock guards in grazing areas (Figure 3.8-4). Each post shall be 10-cm x 10-cm wood or 7.6-cm diameter steel and placed about 0.9-m below ground, rising 0.9-m minimally above ground. This use of barbed wire replaces the requirements of the paragraph above. Installation required prior to sampling.

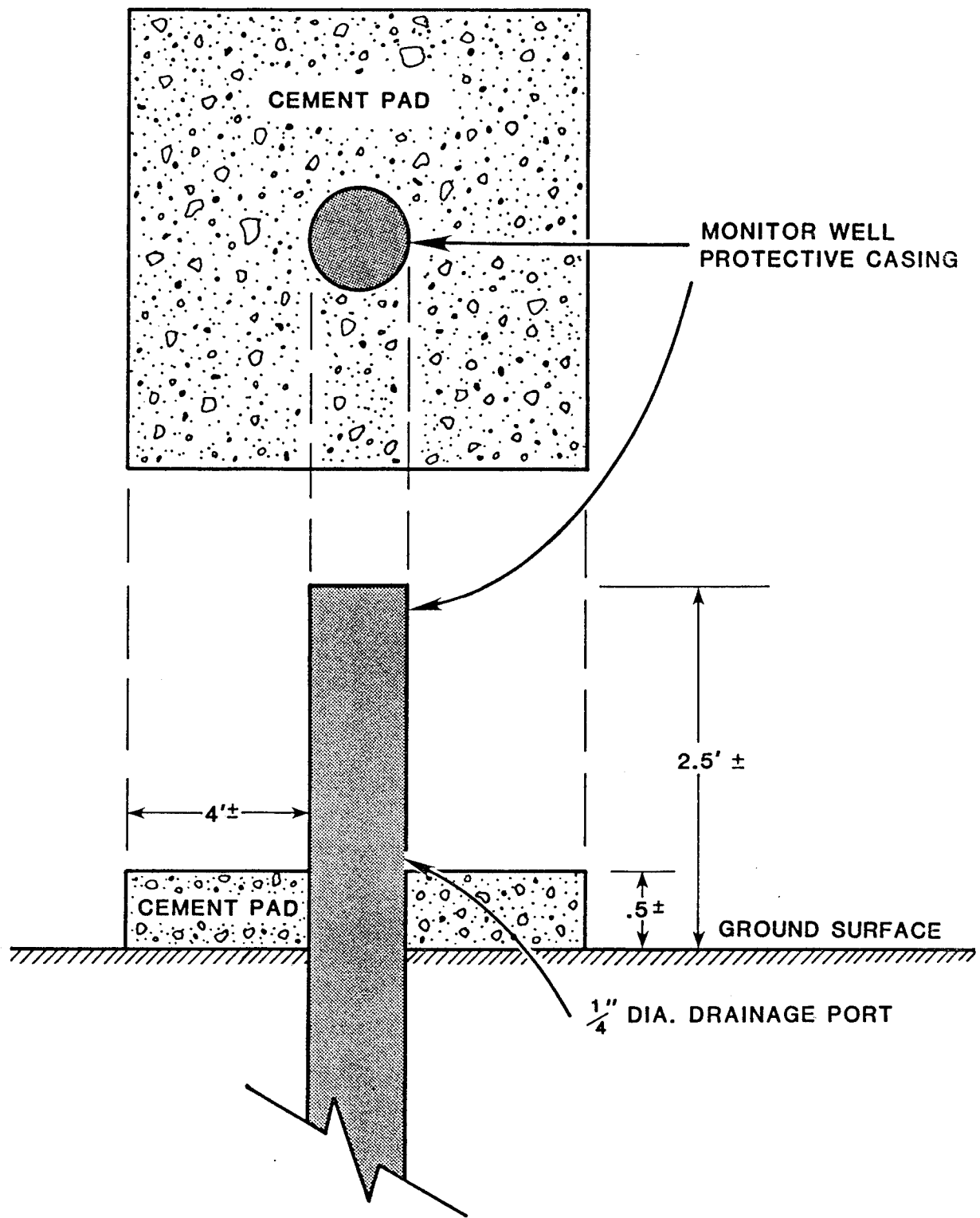

Figure 3.8-3
 SURFACE PROTECTION FOR
 MONITOR WELL

Prepared for:
**U.S. Army Toxic and Hazardous
 Materials Agency**
 Aberdeen Proving Ground, Maryland

10. The placing of an internal mortar collar within the well-protective casing annulus from ground surface to 0.15-m (6-in) above ground surface with a 0.63-cm (0.25-in) diameter hole (drainage port) in the protective casing centered 0.32-cm (1.5-in) above this level (see Figure 3.8-3). The mortar mix shall be (by weight) of one part cement to two parts sand (the granular backfill used about the well screen), with minimal water for placement. Placement required at least 48 consecutive hours prior to well development.
11. The application of an approximately 0.15-m (6-in) thick cement pad extending 0.7-m (2.5-ft) radially from the protective casing (see Figure 3.8-4 for layout and dimensions). Application required prior to development.
12. Unique specifications for flood protection, if applicable, will be submitted for approval.

3.8.6 WELL DEVELOPMENT

Upon completion of the well installation, all monitoring wells will be developed according to procedures described in the USATHAMA Geotechnical Requirements. The development of monitor wells will be performed as soon as practical after well installation, but no sooner than 48 consecutive hours after internal mortar collar placement. The record of well development will be submitted to the Contracting Officer's designated office within 3 working days after development.

Well development will be conducted by means of either a submersible pump or a bottom discharge bailer, with or without a surge block. Development will proceed in the manner described within and continue until the following are met:

1. The well water is clear to the unaided eye.
2. The sediment thickness remaining within the well is less than 5 percent of the screen length.
3. At least 5 well volumes have been removed from the well, (to include the well screen and casing plus saturated annulus, assuming 30 percent porosity).

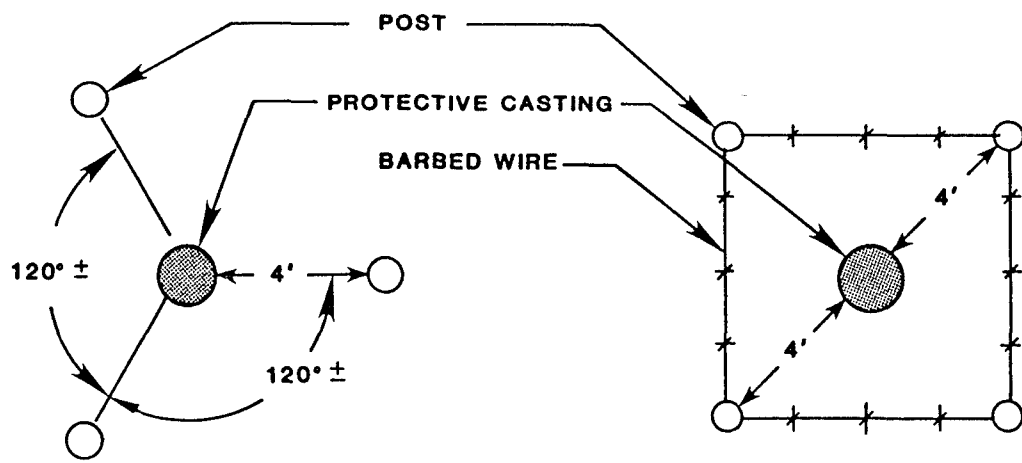

THREE-POST CONFIGURATION

FOUR-POST CONFIGURATION

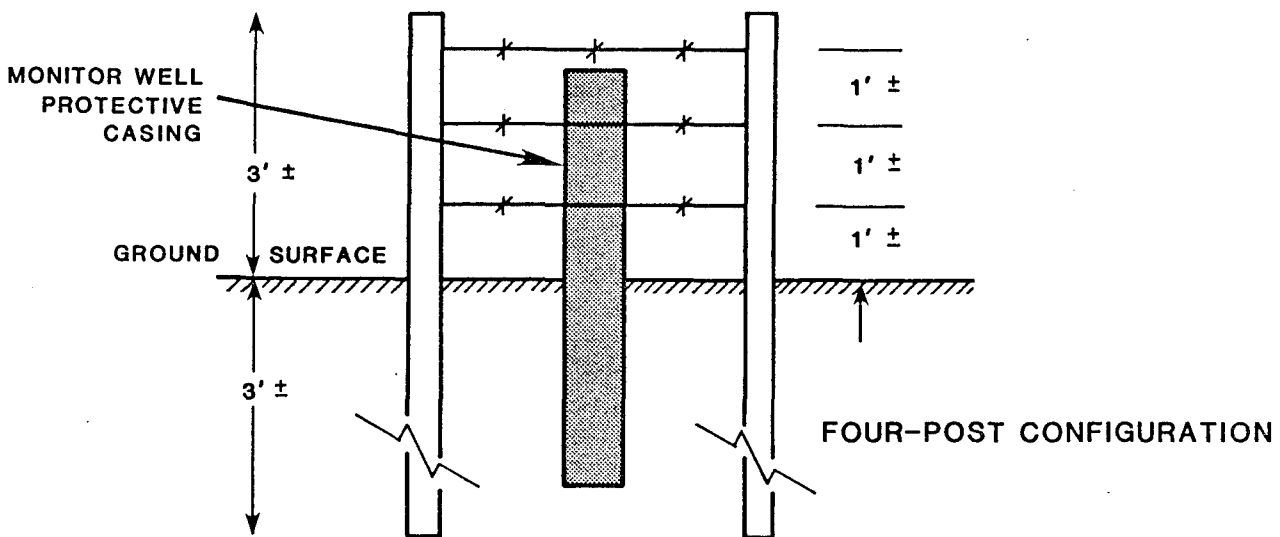
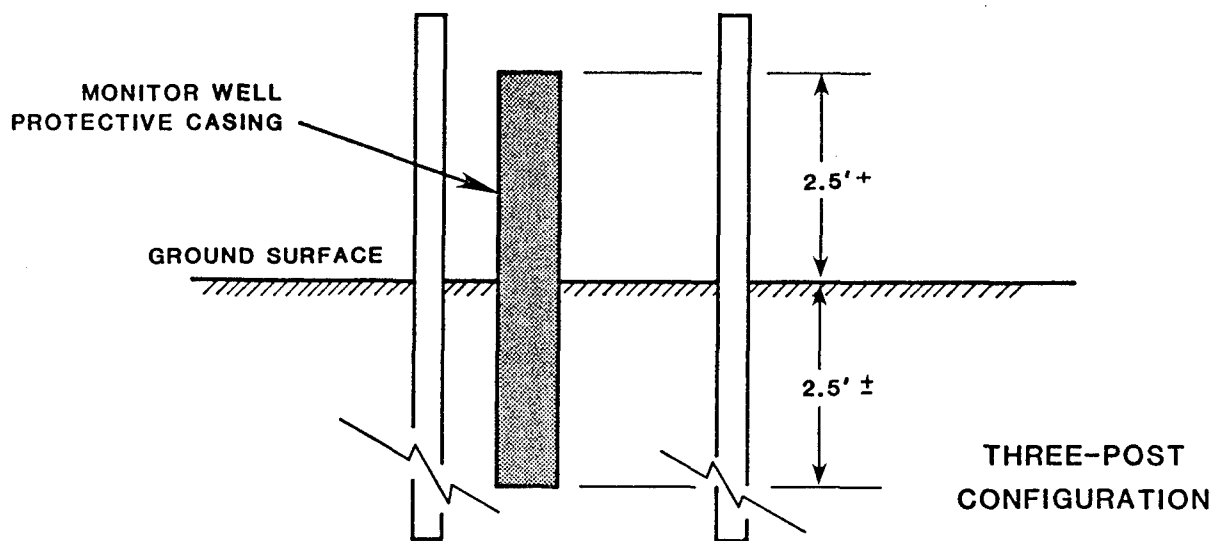

FIGURE 3.8-4
Post Placement Around Wells

Prepared for:
U.S. Army Toxic and Hazardous
Materials Agency
Aberdeen Proving Ground, Maryland

The field hydrogeologist will record field pH and conductivity measurements before, during, and after development of each well. Static water levels will be measured and recorded both before and after well development. The Well Development and Field Data Form (Figure 3.8-5) and data will be submitted to the Contracting Officer or his authorized representative in accordance with the USATHAMA Geotechnical Requirements.

Water will not be added to a well as part of development once the initial seal is placed. However, when a bore, made with or without the use of drilling fluid, contains an excessively thick, particulate-laden fluid which would preclude or practically hinder contractual well installation, the contractor may purge or dilute this fluid with clean water from the approved source. A record of purging fluid losses will be made on the log or diagram, and five times the volume of this loss will be added to the other volumetric removal requirements for well development.

No dispersing agents, acids, disinfectants, or other additives will be used during development or at any other time introduced to the well. During development, water will be removed throughout the entire water column by periodically lowering and raising the pump intake (or bailer stopping point).

Well development will be completed at least 14 consecutive days before well sampling. For each well, a one-pint sample of the last water to be removed during development will be obtained and kept onsite for visual inspection in an area where it will not freeze.

Part of well development will be the washing of the entire well cap and the interior of the well casing above the water table using only water from that well. The result of this operation will be a well casing free of extraneous materials (grout, bentonite, sand, etc.) inside the riser, well cap, and blank casing between the top of the well casing and the water table. This washing will be conducted before and/or during development, not after development.

If problems are encountered during development, the Contracting Officer's designated office will be contacted within 24 consecutive hours for guidance.

The following data will be recorded as part of development:

1. Well designation.
2. Date(s) of well installation.
3. Date(s) and time of well development.
4. Static water level from top of well casing before and 24 consecutive hours after development.
5. Quantity of mud/water lost:
 - a. During drilling.
 - b. During fluid purging.
6. Quantity of fluid in well prior to development:
 - a. Standing in well.
 - b. Contained in saturated annulus (assume 30 percent porosity).
7. Field measurement of pH before, twice during, and after development using an electrometric device (EPA 150.1-Methods for Chemical Analysis of Water and Wastes, EPA 600/4-79-020). Obtain conductance and pH readings concurrently. Calibration standards will be run prior to, during, and after each day's operation in the field.
8. Depth from top of well casing to bottom of well (from diagram).
9. Screen length (from diagram).
10. Depth from top of well casing to top of sediment inside well, before and after development.
11. Physical character of removed water, to include changes during development in clarity, color, particulates, and odor.
12. Type and size/capacity of pump and/or bailer used.
13. Description of surge technique, if used.
14. Height of well casing above ground surface.
15. Quantity of fluid/water removed and time for removal (present both incremental and total values).

Well development will be completed at least 14 consecutive days before well sampling.

For each well, a one-pint sample of the last water to be removed during development will be obtained and kept at the RMA storage facility for visual inspection in an area where it will not freeze. Water removed from the well for development will not be counted toward the volumetric removal requirements of any pre-sample purging (see "Sampling and Chemical Analysis Quality Assurance Program for USATHAMA", April 1982, page 54).

3.8.7 WELL ACCEPTANCE CRITERIA

Wells must be acceptable to the Contracting Officer. Well acceptance will be on a case-by-case basis. The following criteria will be used along with individual circumstances in the evaluation process:

1. The well and backfill will meet the construction and placement specifications of this contract.
2. Wells/boreholes will be clean. No foreign materials (bit chips, drill steel or tools) will permanently remain in the hole prior to well completion.
3. All well casing and screen materials will be free of any unsecured couplings, ruptures or other physical breakage/defects before and after installation.
4. Any casing or screen deformation or bending will be minimal to the point of allowing the insertion and retrieval of the pump and/or bailer optimally designed for that size casing (e.g., a 4.6-cm pump in a 10-cm schedule 40, polyvinyl chloride (PVC) casing is optimal; a 5-cm pump in a 10-cm casing is not optimal).
5. All joints will be constructed to provide a straight, non-constricting, and water-tight fit.
6. Well backfill materials (e.g., filter pack, bentonite, and grout) will form a continuous annular filling around the well casing.
7. Installed wells will be free of extraneous objects or materials (e.g., tools, pumps, bailers, soils, grout, etc.).
8. At least 75 percent of the well screen will be below water at the time of measurement for those screen depths determined by the contractor.

Wells not meeting these criteria are subject to rejection.

Approval Summary

<u>Items Requiring Approval</u>	<u>Time for Approval</u>	<u>Turn Around Time for Evaluation and Recommendation at USATHAMA</u>
Bentonite	Prior to Drilling Equipment Arrival Onsite	6 Working Days
Water	Prior to Drilling Equipment Arrival Onsite	6 Working Days
Abandonment	Prior to Casing Removal or Backfilling	4 Consecutive Hours
Air Usage	Prior to Contract Award	During Proposal/Bid Evaluation
Time of Well Installation	Prior to Drilling	3 Working Days
Granular Backfill	Prior to Drilling	8 Working Hours
Protective Casing	Prior to Drilling	6 Working Days

3.8.8 WELL CONSTRUCTION DIAGRAMS

Each installed well will be depicted in a well diagram. This diagram will be attached to the bore log for that installation and will graphically denote, by depth from ground surface (unless otherwise specified);

1. The bottom of the borehole (that part of the borehole most deeply penetrated by drilling and/or sampling).
2. Screen location(s).
3. Coupling/joint locations.
4. Granular backfill.
5. Seals.
6. Grout.
7. Cave-in.
8. Centralizers.
9. Height of riser without cap/plug (above ground surface).
10. Protective casing detail:
 - a. Height of protective casing without cap/cover (above ground surface).

- b. Base of protective casing.
- c. Drainage port location and size.
- d. Internal mortar collar location.
- e. Gravel blanket height and extent.
- f. Wood/steel post configuration.

Describe on the diagram or on an attachment thereto:

1. The actual quantity and composition of the grout, seals, and granular backfill used for each well.
2. The screen slot size (inches), slot configuration, total open area per foot of screen, outside diameter, nominal inside diameter, schedule/thickness, composition, and manufacturer.
3. The coupling/joint design and composition.
4. Centralizer design and composition.
5. Protective casing composition and nominal inside diameter.
6. The use of solvents, glues, and cleaners to include manufacturer and type (specification).
7. Dates for the start and completion of well installation.

Each diagram will be attached to the borehole log and submitted from the field to the Contracting Officer's designated office within 3 working days after well installation. This submission will not be delayed until all elements of well protection have been installed. A supplemental diagram will be submitted for well protection elements to the same designated office within 3 working days after all elements of well protection are installed. Only the original well diagram and log will be submitted to fulfill the above requirement. Carbon, typed, or reproduced copies will not suffice. A legible copy of the well diagram may be used as a base for the supplemental protection diagram.

3.9 CLEANING PROCEDURES AND MATERIAL DISPOSAL

The steam cleaning of all drilling equipment to include rigs, water tanks (inside and out), auger, drill casings, rods, samplers, tools, recirculation tanks, etc., will be completed prior to project site arrival, followed by washing with approved water between borehole/well sites. Prior to use, all casings, augers, and recirculation and water tanks, etc., will be devoid both inside and out of any asphaltic,

bituminous, or other encrusting or coating materials, grease, grout, soil, etc. Paint, applied by the equipment manufacturer, may not be removed from drilling equipment.

All soil materials encountered, water produced during drilling and water introduced from the approved water source is considered to contain no chemical constituents that require special handling or disposal.

All work areas around the monitor wells sites installed as part of this contract will be restored to a physical condition equivalent to that of pre-installation. This includes the spreading of cuttings, removal of ruts, and reseeding the disturbed areas.

3.10 SURVEYING

Each monitor well installed during this study will be surveyed by a professional land surveyor registered in the State of Colorado. International Technology Limited (ITECH) of Englewood, Colorado, is the designated surveying subcontractor for this RMA task order.

Each monitoring well will be surveyed to establish its map coordinates using a Universal Transverse Mercator (UTM), State Planar, or latitude and longitude grid to within +1-m. Additionally, elevations for the natural ground surface at each sampling well and the top of the well casing will be determined to within +3-cm using the National Geodetic Vertical Datum of 1929.

All survey field data will be recorded and submitted to USATHAMA according to the procedures outlined in the Geotechnical Requirements (USATHAMA, 1983).

All well drilling, installation development, and surveying procedures/materials will be designed and conducted so that the well-acceptance criteria listed in the Geotechnical Requirements (USATHAMA, 1983) will be satisfied. This will ensure that water well sampling tasks will proceed in a timely manner following well installation.

3.11 HYDROGEOLOGIC DATA AQUISITION

Hydrogeologic data will be required in order to determine the direction of water movement, the interaction of ground water with surface water and irrigation ditches, the rate of ground water movement and the quantities of potentially contaminated water moving toward the South Platte River. This data will also be used in evaluation of exposure assessment and in recommended remedial measures.

3.11.1 WATER LEVELS

In order to determine the gradient of shallow ground water and seasonal variations at each monitor well site, at least one complete set of static water level measurements will be made over a single, consecutive 10-hour period for all monitor wells installed for the project. Static levels in borehole not converted to wells will be included if they are determined to be practical and technically appropriate.

All water level measurements will be obtained using a Powers Electric Well Sounder that has been calibrated against a USGS steel tape. Calibration of the electric sounder will be completed on a monthly basis prior to taking monthly water levels. The tape and probe will be rinsed with water from the approved source, wiped with a fresh cloth, and allowed to air dry between consecutive water level measurements. In the event only substances are found on the water surface, water level measurements will be taken with a steel tape prior to purging the well during sampling operations. This procedure will eliminate the possibility of water soluble markers contaminating the well.

The relative elevation difference between any streams, lakes, or major open water bodies within a 90-m radius of a monitor well will be determined and reported to within ±0.15-m.

3.11.2 PERMEABILITY TESTING

Laboratory permeameter tests will be conducted on small samples obtained from the drilling program. Selected samples based on the variability of materials encountered during the drilling program will be tested to obtain a range of permeability values for individual lenticular borehole

materials. This information will be incorporated into the evaluation of the slug test data as a reference for identifying the possible variations in data from the slug test analyses.

A minimum of twenty-one samples will be tested. Groupings of samples will include at minimum sandstone, siltstone, and unconsolidated sands, silts and clays.

3.11.3 AQUIFER TESTING

To determine the hydraulic conductivity and transmissivity of material in the vicinity of the well bore, slug tests will be conducted on the 30 monitor wells. Other methods of determining hydraulic conductivity include an evaluation of grain size distribution and, lab permeability tests. Grain size distribution comparisons are made from comparing the overall distribution of particles against standard curves. An alternative approach is to evaluate the distribution according to relative percent of grain sizes ranges and then calculate a representative hydraulic conductivity. The difference between the actual hydraulic conductivity of the formation in the field and values obtained from grain size distribution are due to disturbance of the sample which eliminates any horizontal variations. Lab permeability tests are also to be used for comparison to other test methods, however this method is conducted on a disturbed sample and may not be characteristic of field conditions. The slug test is the preferred method of aquifer testing because under contaminated aquifer conditions disposal of large volumes of water is not necessary, the method stresses the aquifer for several feet surrounding the well bore and the test is conducted on undisturbed formation material. Grain size distribution analyses and lab permeability tests will also be conducted as a check on the reliability and variation of calculated hydraulic conductivity values from the slug testing.

In the slug test, the water level in a well is lowered or raised essentially instantaneously by rapidly removing or adding a fixed volume of water followed by observation of the change in water level with time.

All sudden water level changes associated with testing will be recorded by use of electronic instrumentation.

Data from the slug tests will be evaluated using analytical procedures that allow the field boundary conditions to be approximated to the maximum possible extent. The field conditions encountered are as follows:

1. Semiconfined and confined flow conditions in the Denver sands.
2. Multiple aquifers of finite thickness and infinite extent (with respect to the radius of the wells).
3. Fully penetrating well screens, and
4. Transient or nonsteady state flow conditions (during tests).

Three analytical procedures considered appropriate for evaluation of the test data are: Hvorslev (1951), Bouwer and Rice (1976), Cooper et al. (1967). Hvorslev addressed conditions 1. (partially) and 3. (partially) of the above list, whereas Bouwer and Rice addressed conditions 1. (partially), 2, and 3. Cooper et al. addressed each of the four boundary conditions, either directly or indirectly, by using a nonsteady flow differential equation to provide an exact solution for the heads in and around a well after a known volume of water is instantaneously withdrawn from the well. The Cooper et al. method for the remaining test data involves the assumption that well storage, aquifer storage, and nonsteady-state flow must be considered to accurately evaluate an aquifer's response to a slug test (Cooper et al. 1967; Black, 1978; Walton, 1978; and Boulton and Streltsova, 1976).

The advantages of the slug test method are numerous:

1. Long-term pumping of a contaminated well is not necessary. Typically, no water is removed or added during the slug test. Water is displaced using a pipe of known volume. This eliminates the problem of disposing of contaminated well water upon completion of the test and eliminates introduction of foreign water to the well during the test.
2. Low cost per test. This method results in an aquifer test which is completed in less than hour. The test may be repeated at each site to ensure accurate results.

3. High precision is possible as a result of the fast-reacting electronics of the equipment and the ability to run several tests at each well in a short amount of time to eliminate spurious results.
4. Hydraulic parameters are derived for each well rather than a selected few wells.

4.0 GROUND WATER SAMPLING

4.1 SAMPLING NETWORK

Ground water sampling will begin after the 30 new monitor wells have been allowed to reach equilibrium (no less than 14 days after well development in accordance with USATHAMA requirements). All field data will be recorded in a format directly compatible with the USATHAMA DMS input requirements. All field log books will be provided to USATHAMA at the termination of the study.

The following procedures will be followed on the day of sampling for the 30 monitor wells:

1. The depth to water will be measured from the top of casing.
2. The depth to the water/sediment interface will be sounded and recorded. The volume of the water in the well will be calculated.
3. Samples will be taken after the fluid in the screen, well casing, and saturated annulus has been exchanged 5 times. In the event of low well yields (e.g., in the presence of fine-grained sediments), some wells may have slow recovery rates. A decision to reduce the well purging to less than 5 volumes will be recommended by the contractor only if excessive time would elapse attempting to collect 1 or 2 samples from low-yielding wells. This decision is subject to approval by USATHAMA. The amount of fluid purge will be measured and recorded. Conductivity, pH, and temperature will be measured at the start, once during, and at the end of the fluid purging procedure. These data will be forwarded to USATHAMA at the end of sampling. Sampling will be accomplished by a dedicated stainless steel bailer for each well. Care will be taken not to agitate the sample.
4. To protect the wells from contamination during sampling procedures, the following guidelines will be followed:
 - a. A separate bailer will be supplied for each well. The bailer will be stored in each well between sampling to minimize contamination.

11/09/84

- b. All sampling will be performed by the disposable bailer or a positive action piston pump. If a pump is used to purge the standing water from the well, the pump and the hoses will be thoroughly cleaned between the samples, using the approved drilling water source.
 - c. All sampling equipment will be protected by using polyethylene plastic sheeting to prevent soil contamination from tainting the ground water samples.
 - d. Materials incidental to sampling such as bailer ropes (monofilament line) and tubing must also be flushed with distilled water. Sampling equipment must be protected from ground surface contamination by clean plastic sheeting. Plastic sheeting is discarded after each use. No sampling should be accomplished when wind blown particles may contaminate the sample or sampling equipment.
5. Onsite measurements of water quality obtained during the sampling trip will consist of conductivity, temperature, and pH. These data will be presented in the quarterly and annual reports. Calibration standards will be run and recorded prior to, during, and after each sampling day.

During sampling of each monitor well, information regarding the sampling will be kept in a notebook. The following data will be collected:

1. Well number;
2. Date;
3. Time;
4. Static water level;
5. Depth of well;
6. Number of bailer volumes removed, if applicable;
7. Pumping rate, if applicable;
8. Time of pumping, if applicable;
9. Drawdown water level;
10. In situ water quality measurements such as pH, specific conductance, and temperature;
11. Fractions sampled and preservatives;

12. Weather conditions and/or miscellaneous observations; and
13. Signature of sampler and date.

Samples will be collected in a manner which will minimize aeration and prevent oxidation of reduced compounds. The sample bottle should be partially filled with the water to be sampled, and the contents should be agitated and discarded prior to filling the bottle with sample. Volatile samples will be collected in duplicate directly from the bailer at each well and placed in the canisters containing activated carbon provided to prevent contamination. Volatile fractions will not be filtered. If the preserved sample bottle containing the volatile fraction is contaminated by dropping the septum or touching the septum or lips of the bottle, it will be discarded and a clean bottle issued and labeled. Under no circumstances will volatile fractions be transferred from other sampling containers. All samples for organic chemical analyses will be placed in amber glass bottles with teflon lined lids.

Samples for inorganic chemical analyses will be placed in polyethylene bottles. The bottles will be filled to the top and capped securely. Samples for metals analysis will be filtered in the field using a 0.45- μ membrane filter which has been rinsed with ultrapure atomic-absorption-grade nitric acid. In between samples, the equipment is rinsed and cleansed, as described in the QC plan for metals equipment/glassware. After the filtration apparatus is set up for the next sample, three 25-ml aliquots of distilled water are filtered to purge and rinse the equipment, followed by two 25-ml aliquots of the next sample which are discarded.

Each sample will be carefully labeled and will be shipped in styrofoam ice chests and will be kept below 4°C from time of sample collection until analysis. The products of ground water sampling will be:

1. A water sample from each well;
2. A replicate water sample from one of the wells;
3. Onsite measurements of conductivity, temperature, and pH; and
4. Depth-to-water and depth-to-sediment/water interface readings at each well.

11/09/84

Each replicate sample will be identified in accordance with labeling procedures for each site. Replicate sample identification will be indistinguishable from other sample sets.

All field data will be recorded in a format directly compatible with the USATHAMA DMS input requirements. All field log books will be provided to USATHAMA at the termination of the study.

4.2 SAMPLE SHIPMENT/CHAIN OF CUSTODY

The ESE Site Geologist will serve as Sampling Team Leader and will supervise and assist in the sampling of all ground water and surface water sampling stations. Samples will be labeled, filtered, and preserved in the field. A log sheet will be filed and signed in by the Site Geologist to serve as a check that all samples and operations are complete. Samples will be packed in styrofoam ice chests with sufficient ice to maintain $\leq 4^{\circ}\text{C}$ during transport to the laboratory. The ice will be double-bagged to prevent contact of the melt water with the samples. All samples will be checked for integrity and lid closure to prevent leakage.

The sampling logistics will occur as follows. The time elapsed between the first sample collection and initiation of processing in the laboratory will be approximately 24 to 30 hours, based on transportation schedules.

The Chemical Analysis Supervisor will be notified of the shipment of samples and estimated time of arrival of the sample being driven. The Chemical Analysis Supervisor or a designate will receive the sample, verify the contents, and sign the log sheet. Samples are stored at ESE in a 4°C -refrigerator under the control of the Data Management Supervisor in the Sample Control Center. The procedures for sample fraction control during analysis are described in the Data Management Plan.

Any samples which are leaking, any situations in which holding times are not met, or other problems which may compromise the data, are noted at the time of receipt of the samples and reported to the QA Supervisor for

development of corrective action. The QA Supervisor verifies the chain-of-custody record of each sample set.

5.0 SURFACE WATER AND STREAM SEDIMENT SAMPLING

5.1 SAMPLE STATION LOCATIONS

The offsite sampling locations for surface water and sediments are shown in Figure 5.0-1. Quarterly sampling at each station will consist of one water sample and one sediment sample.

The station locations are described as follows:

1. South Platte River at I-270 below the Sand Creek confluence. This station will represent the South Platte River main stem as it enters the study area.
2. Burlington Ditch at 64th Avenue. This station will establish water quality in the Burlington Ditch and O'Brian Canal before any influence of RMA and water quality in the South Platte River before the influence of Sand Creek.
3. South Platte River at Highway 7 in Brighton. When compared with Station 1, analysis from this site will monitor changes in the South Platte River within the study area.
4. O'Brian Canal at 112th Avenue, above the Second Creek confluence. This station will monitor the impacts on water quality due to RMA ground water plumes.
5. Second Creek above the confluence with O'Brian Canal. Samples from this point are required to determine the influence of contaminants in Second Creek on O'Brian Canal.
6. Burlington Ditch at Highway 2. Data from this station will be compared to Station 2 in order to determine what contaminants enter the Ditch as it crosses the study area.
7. Barr Lake at mid-pool. This station will be used to evaluate the extent to which Barr Lake may operate as a "sink" for RMA contaminants.
8. Barr Lake near the inlet from O'Brian Canal. This station will provide additional data on Barr Lake. Two stations are included to account for undefined circulation and sediment deposition patterns.
9. First Creek at Highway 2. Data from this station will establish the contaminant load First Creek is contributing to

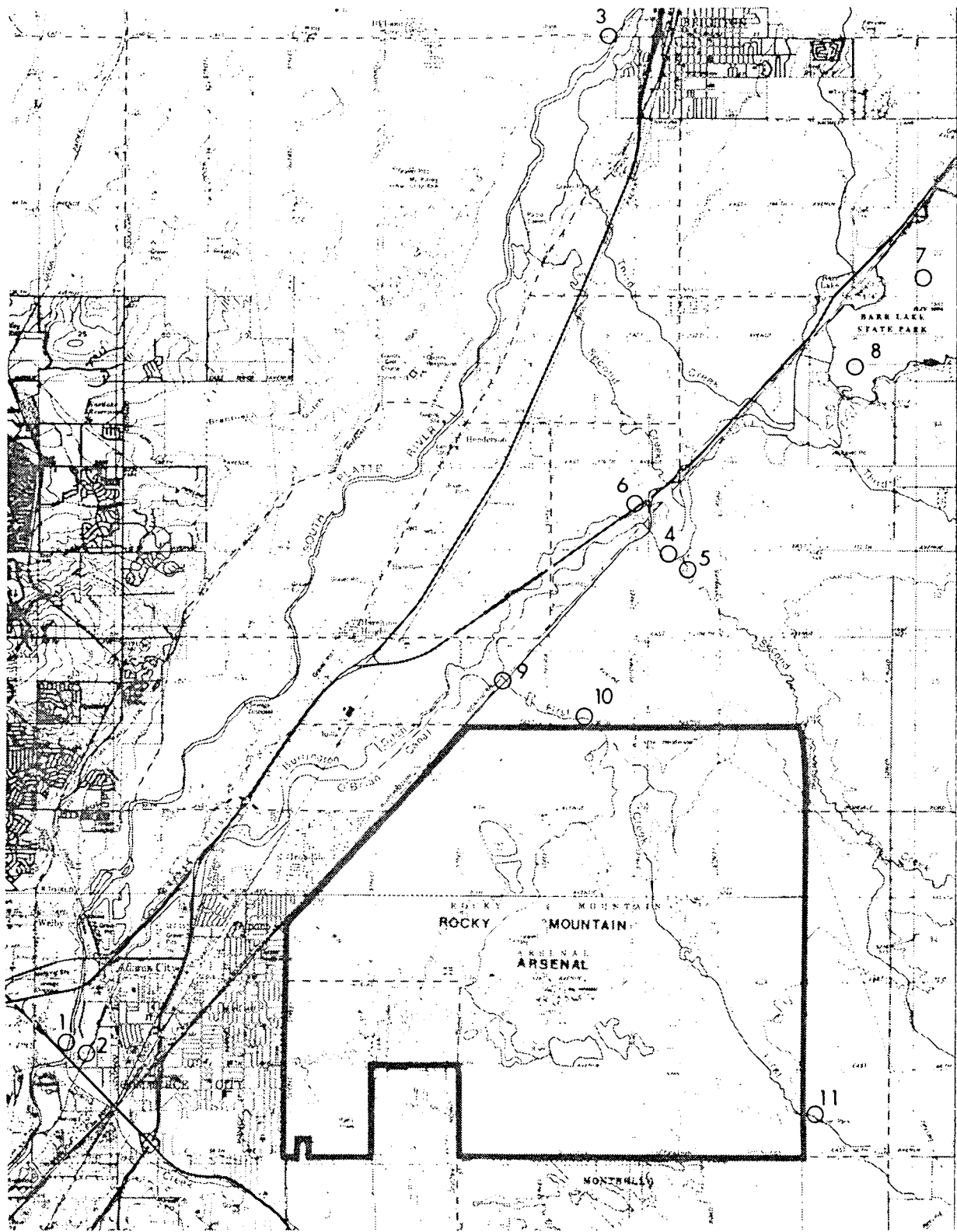

Source: ESE, 1984

Figure 5.0-1
Proposed Surface Water
Sampling Sites

Prepared for:
**U.S. Army Toxic and Hazardous
Materials Agency**
Aberdeen Proving Ground, Maryland

O'Brian Canal and/or Burlington Ditch. This station will be equipped with a continuous water level recorder so that variations in flow may be calculated for variable time periods and as a comparison to recorded daily flows in irrigation canals diverting water from First Creek.

10. First Creek at 96th Avenue. This station will establish the quality of First Creek as it exits RMA.
11. First Creek at Buckley Road. This station will monitor First Creek as it enters RMA.

5.2 FLOW MEASUREMENT

Flows on the South Platte River will be obtained from USGS gaging data. Flows on other streams will be calculated each time samples are taken by measuring and drawing a cross-section and measuring velocity with a current meter. The channel at the point of measurement should be straight with a regular cross-section. There should be at least ten velocity measurements made across the channel at right angles to the direction of flow and spaced an equal distance apart. At each measuring point, if the depth of flow is 1-m or more, the velocity is measured at 0.2 and 0.8 of the depth from the water surface, and the velocity at the measuring point is taken as the average of these two values. If the depth of flow is less than 1-m, one reading at 0.6 of the depth from the water surface will be taken.

The depth at each measuring point will be multiplied by the sectional width, which extends halfway to the preceding measuring point and halfway to the following measuring point to compute a cross-sectional area. The product of sectional area and stream velocity produces a sectional flow, and the sum of the sectional flows is the desired stream flow.

Data collected from the continuous recorder at station location 9 (First Creek at Highway 2) will be reduced and tabulated. Flows will be calculated for average daily flow, average monthly flow, maximum monthly flow, and minimum monthly flow. These data will then be evaluated against ditch records to assist in determining the amount of flow

directed into the irrigation canals. These data will also be used to assist in an evaluation of water balance for the project area. Stream gaging data on First Creek entering and leaving RMA have been collected over the past several years. Any pertinent data collected from these programs will in the future be used as a check on calculations. It is also possible that a Parshall flume on First Creek at the O'Brian Canal could be used to obtain flow measurements during sampling or be fitted with a recorder to provide continuous flow records. This possibility will be discussed with the canal operators.

In order to ensure consistent procedures, it is important that continuity be maintained in sampling teams. Whenever new personnel are introduced, they should be thoroughly trained, including participation in one full quarterly sampling along with existing personnel.

5.3 SAMPLE COLLECTION

5.3.1 SURFACE WATER

At most stations, these samples can be obtained by entering the stream downstream, wading to the sample point, and filling the water a sediment containers directly as grab samples. Water will be taken as a grab sample from mid-channel by holding the container just under the water surface and allowing it to fill.

These sampling procedures will be modified as necessary for stations on the South Platte River and during high flow conditions on other streams, when wading of mid-channel may be impossible. Any changes in procedure will be documented in the sampling report.

For those sample points in Barr Lake, a boat will be required. Water will be taken with a depth integrated sampler by lowering it to near bottom depth without disturbing the bottom and raising it to the surface at a uniform rate. Sediment will be taken using a dredge and will be emptied directly into the sample container.

Surface water samples may be obtained under varying circumstances. The sampling procedures in EPA 600/4-77/039, "Sampling of Water and

Wastewater" will be considered in obtaining surface water samples. USATHAMA QA Guidelines will take precedence over EPA Guidelines whenever conflicts in techniques exist. Sampling will be avoided immediately after extreme precipitation events or during other unusual circumstances.

5.3.2 SEDIMENTS

Sediment will generally be collected using a dredge at mid-channel and emptying the dredge directly into the sample container. Prior to sampling sediments in a stream, the sampling device will be rinsed with stream water at a point downstream from the sampling location to avoid disturbing the sediments at the sampling point. Also, sampling will be accomplished upstream of any disturbances in the stream caused by the sampler or sampling team. Prior to sampling sediments in a pond or lagoon, the sampling device will be rinsed with water near the sampling point. However, caution must be exercised to avoid disturbing the sediments at the sampling point by the rinsing activities.

The type of sampler used will be dictated by the nature and the accessibility of the sediments. In addition, the type of sampler will be appropriate for obtaining the desired sample, i.e., a core sampler should not be used to obtain top sediment.

Sampling devices will be carefully rinsed with water from the sampled stream, pond or lagoon prior to sampling and with water from a USATHAMA designated source after each set of samples is collected in a particular sampling area.

Each sample obtained during the first quarterly sampling will be analyzed for all RMA migrating contaminants (see Section 1.1-7). Based on these results, the sampling network and analytical parameters may be altered for subsequent quarters. At least once each year, all samples should be analyzed for all RMA migrating contaminants. The data obtained from first quarter samples will be used to adjust the surface water sediment monitoring station locations as necessary for subsequent quarterly sampling events.

5.4 SAMPLE PRESERVATION PROCEDURES

To prevent or retard the degradation/modification of chemicals in samples during transit and storage, the samples will be preserved and stored as outlined in Appendix A for the compounds of interest. Efforts to preserve the integrity of the samples will be initiated at the time of sampling and will continue until analyses are performed. Those samples containing organic compounds will be preserved immediately by refrigeration at or below 4°C and stored in amber glass bottles with teflon-lined lids. These bottles and lids will be cleaned as outlined in Section 4.0. Those samples containing inorganic compounds will be stored in plastic polyethylene containers and immediately preserved by refrigeration at or below 4°C.

6.0 CHEMICAL ANALYSIS PROGRAM

The chemical analysis program in the RMA contamination assessment consists of the quantitative analysis of ground water, surface water, and sediment samples for the organic and inorganic contaminants given in Table 6.0-1. These specific parameters have been identified as contaminants on RMA by the COE WES (Spain et al, 1983). These contaminants will be collectively referred to as "RMA migrating contaminants" in sections of this document.

6.1 CHEMICAL ANALYSIS SCHEDULE

The number of samples and anticipated date of analysis for each matrix type are summarized in the schedule in Table 6.1-1. The schedule includes the analysis of 125 consumptive use ground waters from existing wells, 30 ground waters from new monitor wells (twice at quarterly intervals), and 11 surface water/sediment samples (twice at quarterly intervals). All samples will be analyzed for the parameters in Table 6.0-1. A water supply sample will be analyzed to determine its suitability as a drilling water source. This sample will be analyzed to determine if it is free from the RMA migrating contaminants.

6.2 CHEMICAL ANALYSIS METHODS

Table 6.2-1 is a summary of the analytical methods required for the contamination assessment at RMA. The consumptive use water analysis program occurs early in the survey and requires expeditious certification of certain analytical methods. Table 6.2-1 also summarizes the current quantitative certification status in water for all of the contaminants included in the offpost RMA survey. ESE will subcontract the analysis of the consumptive use water samples for certain analytes to Midwest Research Institute (MRI) of Kansas City, Missouri. These analytes consist of several organic compounds for which MRI is quantitatively certified and ESE is not, and include aldrin, endrin, dieldrin, isodrin, DCPD, DBCP, and organosulfur compounds. ESE will conduct all other analyses for the consumptive use water samples including DIMP, DMMP, toluene, benzene, xylene, the chlorinated organic solvents, and the anions. Prior to consumptive use water sampling, ESE will certify

Table 6.0-1. Contaminants to be Analyzed During Assessment

Aldrin
Endrin
Dieldrin
Isodrin
Dicyclopentadiene (DCPD)
Dibromochloropropane (DBCP)
Diisopropylmethylphosphonate (DIMP)
Dimethylmethylphosphonate (DMMP)
P-Chlorophenylmethylsulfone (PCPMSO₂)
P-Chlorophenylmethylsulfoxide (PCPMSO)
P-Chlorophenylmethylsulfide (PCPMS)
1,4-Dithiane
1,4-Oxathiane
Toluene
Benzene
Xylene
Chlorobenzene
Chloroform
Carbon Tetrachloride
trans-1,2-Dichloroethylene
Trichloroethylene
Tetrachloroethylene
Chloride
Fluoride

Source: ESE, 1984.

Table 6.1-1. Chemical Analysis Schedule

Sample Type	Number of Samples	Date of Analysis
Drilling water	1	February, 1985
Consumptive Use Ground Water	125	November, 1984 - January, 1985
Ground Water	30	April - May, 1985
Surface Water	11	April - May, 1985
Sediment	11	April - May, 1985
Ground Water	30	July - August, 1985
Surface Water	11	July - August, 1985
Sediment	11	July - August, 1985

Source: ESE, 1984.

Table 6.2-1. Analytical Methods and Certification Status for Aqueous Samples

RMA Migrating Contaminants	Analytical Method	Certification Status ()†	USATHAMA Method Number
<u>Chlorinated Purgeables</u>			
Chlorobenzene	Purge and Trap GC/Hall*	1 (ESE)	7D
Chloroform	Purge and Trap GC/Hall	1 (ESE)	7D
Carbon Tetrachloride	Purge and Trap GC/Hall	1 (ESE)	7D
Dichloroethylene	Purge and Trap GC/Hall	1 (ESE)	7D
Trichloroethylene	Purge and Trap GC/Hall	1 (ESE)	7D
Tetrachloroethylene	Purge and Trap GC/Hall	1 (ESE)	7D
<u>Organosulfur Extractables</u>			
P-Chlorophenylmethylsulfone (PCPMSO ₂)	Solvent Extraction GC/FPD††	2 (MRI)	NC**
P-Chlorophenylmethylsulfoxide (PCPMSO)	Solvent Extraction GC/FPD	2 (MRI)	NC
P-Chlorophenylmethylsulfide (PCPMS)	Solvent Extraction GC/FPD	2 (MRI)	NC
1,4-Dithiane	Solvent Extraction GC/FPD	2 (MRI)	NC
1,4-Oxathiane	Solvent Extraction GC/FPD	2 (MRI)	NC
<u>Pesticide Extractables</u>			
Aldrin	Solvent Extraction GC/ECD†††	2 (MRI)	NC
Endrin	Solvent Extraction GC/ECD	2 (MRI)	NC
Dieldrin	Solvent Extraction GC/ECD	2 (MRI)	NC
Isodrin	Solvent Extraction GC/ECD	2 (MRI)	NC
<u>Non-Chlorinated Aromatics</u>			
Toluene	Solvent Extraction GC/PID***	2 (ESE)	NC
Benzene	Solvent Extraction GC/PID	2 (ESE)	NC
Xylene	Solvent Extraction GC/PID	2 (ESE)	NC
<u>Anions</u>			
Chloride	Direct Injection IC††††	2 (ESE)	NC
Fluoride	Direct Injection IC	2 (ESE)	NC
<u>Organophosphorus Extractables</u>			
Diisopropylmethylphosphonate (DIMP)	Solvent Extraction GC/NPD****	2 (ESE)	NC
Dimethylmethylphosphonate (DMMP)	Solvent Extraction GC/NPD	2 (ESE)	NC
<u>Miscellaneous Extractables</u>			
Dibromochloropropane (DBCP)	Solvent Extraction GC/ECD****	2 (MRI)	NC
Dicyclopentadiene (DCPD)	Solvent Extraction GC/FID†††††	2 (MRI)	NC

†() = Name in parentheses refers to organization whose status is described. Status numbers refer to the following:
 1. Certified quantitatively.
 2. Quantitative method submitted to USATHAMA for review.

* GC/Hall = Gas Chromatograph equipped with a Hall Detector.
 †† GC/FPD = Gas Chromatograph equipped with a Flame Photometric Detector.
 ** NC = Not Certified.
 ††† GC/ECD = Gas Chromatograph equipped with an Electron Capture Detector.
 *** GC/PID = Gas Chromatograph equipped with a Photoionization Detector.
 †††† IC = Ion Chromatograph.
 **** GC/NPD = Gas Chromatograph equipped with a Nitrogen Phosphorus Detector.
 ††††† GC/FID = Gas Chromatograph equipped with a Flame Ionization Detector.

methods for DIMP and DMMP, toluene, benzene, xylene, and the anions. Table 6.2-2 lists the analytes and the laboratory scheduled to perform the specific analysis for the drilling water and consumptive use ground water samples. Table 6.2-3 lists the detection limits of those methods presently certified, or the anticipated detection limits for those methods either under review or under certification procedures along with their corresponding health criteria. The health criteria were obtained from various sources which are outlined in Table 6.2-4. The method for aldrin, dieldrin, endrin, and isodrin will be recertified to achieve a detection limit of approximately 0.1 µg/L. The anticipated detection limits in Table 6.2-4 will be deemed acceptable for this project even though they are not all below recommended criteria.

ESE will certify quantitatively for all the RMA migrating contaminants in both water and sediment and will be performing all analyses on the two quarterly sampling events occurring in April 1985 and July 1985. Although there are no known health criteria for the RMA migrating contaminants in sediments, ESE proposed to certify for the RMA migrating contaminants in sediment with an anticipated detection limit of approximately 1 to 5 microgram per gram (µg/g).

Table 6.2-2. Analytical Laboratory Performing Analysis of the Drilling and Consumptive Use Ground Water Samples

Analyte	ESE	MRI
Aldrin		X
Endrin		X
Dieldrin		X
Isodrin		X
Dicyclopentadiene (DCPD)		X
Dibromochloropropane (DBCP)		X
Diisopropylmethylphosphonate (DIMP)	X	
Dimethylmethylphosphonate (DMMP)	X	
P-Chlorophenylmethylsulfone (PCPMSO ₂)		X
P-Chlorophenylmethylsulfoxide (PCPMSO)		X
P-Chlorophenylmethylsulfide (PCPMS)		X
1,4-Dithiane		X
1,4-Oxathiane		X
Toluene	X	
Benzene	X	
Xylene	X	
Chlorobenzene	X	
Chloroform	X	
Carbon Tetrachloride	X	
trans-1,2-Dichloroethylene	X	
Trichloroethylene	X	
Tetrachloroethylene	X	
Chloride	X	
Fluoride	X	

X = Laboratory is Performing Analysis.

Source: ESE, 1984.

Table 6.2-3. Present and Anticipated Certified Detection Limits

Analyte	Detection Limit (µg/l)	Recommended Health-Related Guideline (µg/l)
Aldrin	0.1†	0.015
Endrin	0.1†	0.2
Dieldrin	0.1†	0.014
Isodrin	0.1†	1
Dicyclopentadiene (DCPD)	24**	540
Dibromochloropropane (DBCP)	0.11	0.2
Diisopropylmethylphosphonate (DIMP)	1.7**	500
Dimethylmethylphosphonate (DMMP)	16**	7,000
P-Chlorophenylmethylsulfone (PCPMSO ₂)	25**	0.34
P-Chlorophenylmethylsulfoxide (PCPMSO)	25**	0.23
P-Chlorophenylmethylsulfide (PCPMS)	10**	0.32
1,4-Dithiane	10**	1
1,4-Oxathiane	25**	NA*
Toluene	5.0†	19,000
Benzene	5.0†	8.4
Xylene	5.0†	30,000
Chlorobenzene	0.58**	488
Chloroform	1.4**	2.4
Carbon Tetrachloride	2.4**	5.3
trans-1,2-Dichloroethylene	1.2**	NA
Trichloroethylene	1.1**	35
Tetrachloroethylene	1.3**	8
Chloride	4,800**	250,000
Fluoride	1,200**	2,400

* NA = Not Available
 † Detection Limit Goal
 ** Currently Achieved Detection Limit

Source: ESE, 1984.

Table 6.2-4. Compounds Considered As Contaminants For RMA Study And Status Of Toxicological Data Availability

Compound Name (Status)*	Baseline Document	Recommended PPLV (ug/L)	Notes
1,2-Dibromo-3-Chloropropane † (1)	NCI Bioassay (NIH 82-1762)	0.2 (10 ⁻⁵ risk)	CDH agreement
Diisopropylmethylphosphonate (2)	USAMBRDL Contract DAMD 17-77-C-7003	500	CDH agreement
Dicyclopentadiene (2)	USAMBRDL Contract DAMD 17-77-C-7003	540	USAMBRDL estimate
Dimethylmethylphosphonate (2)	USAF Contract AFAMRL-TR-82-87	7,000	USAMBRDL estimate
P-Chlorophenylmethyl sulfide † (3)	USAMBRDL Contract DAMD 17-77-C-703B	0.32 (10 ⁻⁵ risk)	USAMBRDL estimate
P-Chlorophenylmethyl sulfoxide † (3)	USAMBRDL Contract DAMD 17-77-C-703B	0.23 (10 ⁻⁵ risk)	USAMBRDL estimate
P-Chlorophenylmethyl sulfone † (3)	USAMBRDL Contract DAMD 17-77-C-703B	0.34 (10 ⁻⁵ risk)	USAMBRDL estimate
1,4 Dithiane (4)	No Information	1	conservative default estimate
Aldrin † (1)	EPA WQC Report PB81-117301	0.015 (10 ⁻⁵ risk)	From water quality criteria (WQC)
Dieldrin † (1)	EPA WQC Report PB81-117301	0.014 (10 ⁻⁵ risk)	From WQC
Endrin (1)	EPA WQC Report PB81-117301	0.2	Drinking water std
Isodrin (3)	Review, DAMD 17-77-C-7037	1	Drinking water std for endrin
Toluene (1)	EPA WQC Report PB81-117855	19,000	
Xylene (2)	Documentation, TLV 1980	30,000	TLV 435 mg/m ³
Benzene † (1)	EPA WQC Report PB81-117293	8.4 (10 ⁻⁵ risk)	From WQC
trans-1,2-Dichloroethylene		NA	
Trichloroethylene † (1)	EPA WQC Report PB81-117871	35 (10 ⁻⁵ risk)	From WQC
Tetrachloroethylene † (1)	EPA WQC Report PB81-117830	8 (10 ⁻⁵ risk)	From WQC
Chloroform † (1)	EPA WQC Report PB81-117442	2.4 (10 ⁻⁵ risk)	From WQC
Carbon Tetrachloride † (1)	EPA WQC Report PB81-117376	5.3 (10 ⁻⁵ risk)	From WQC
Fluoride Salts (1)	Review, DAMD 17-77-C-7037	2,400	Drinking water standard
Chloride		250,000	Drinking water standard
Chlorobenzene	EPA WQC Report PB81-117376	488	From WQC

* Category 1 - Extensive information.
 Category 2 - Sufficient information from which to extrapolate dose estimates.
 Category 3 - Sparse information from which to extrapolate dose estimates.
 Category 4 - No information found.
 † Compounds that, on the basis of mammalian studies, may be potentially carcinogenic to humans.
 NA - Not Available

Source: USAMBRDL, 1984.

7.0 QUALITY ASSURANCE

7.1 FIELD LABORATORY QA PROGRAM

A necessary and integral part of the Technical Plan for RMA is the project-specific QA Plan describing the application of ESE procedures to control and monitor USATHAMA sampling and analysis efforts. ESE has developed a Field Laboratory QA Plan applicable to any survey task under this contract, to control sampling and analysis activities on RMA and all other contracted survey tasks. This plan has been based on USATHAMA April 1982 QA Program requirements and complies with ESE policy.

MRI will serve as a subcontractor to ESE for partial analysis of potable water samples and will comply with the ESE Field Laboratory QA Plan. A laboratory QA coordinator will be appointed in the MRI and ESE laboratories to ensure compliance with USATHAMA QA program and perform the QA duties in that laboratory.

Prior to analysis of samples, a briefing visit will be made by the ESE Chemical Analysis Manager and the Project QA Supervisor to MRI. The purpose of this visit will be to review analytical procedures and the QC requirements of the Field Laboratory QA plan. This meeting will also establish procedures for transmission and documentation of data to the ESE laboratory for entry into the USATHAMA IR-DMS. In addition, the Project QA Supervisor will visit the MRI laboratory during the consumptive use water analysis effort to ensure compliance with the Field Laboratory QA Plan.

The Field Laboratory QA Plan will be employed to ensure the production of valid, properly formatted data defining the precision, accuracy, and sensitivity of each method used for USATHAMA sampling and analysis efforts. Specific RMA QC requirements are described in the following sections.

7.2 SPECIFIC RMA REQUIREMENTS

7.2.1 FIELD PROCEDURES

Two separate field sampling QA audits of the ground water and surface water sampling procedures for RMA will be conducted by the Project QA Supervisor. Samples must be collected in properly cleaned containers, promptly and properly preserved, and transported to the ESE laboratory. The ESE Field Laboratory QA Plan describes the procedures to monitor adherence to approved sampling QC practices.

Field operations to be audited include: (1) sample handling; (2) use of sample containers for the particular analysis; (3) use of approved sampling techniques to minimize loss of volatiles; and (4) field documentation practices. The Field Sampling Audit Checklist will be completed, and a QA Field Audit Report will be submitted to the Project Site Manager within 30 days of the QA field audit trip. Any procedures not complying with USATHAMA and ESE sampling QC practices will be identified to the ESE Site Manager within 24 hours of observation, and proper corrective actions will be taken.

7.2.2 SAMPLE PREPARATION AND BATCHING

The Project QA Supervisor will monitor the sample preparation procedures to assure compliance with USATHAMA requirements. These procedures include proper selection of container materials and preservation techniques.

The Laboratory QA Coordinator will establish Army lots after the samples have been logged into the laboratory. The ground water and surface water samples will be batched into groups of approximately 10 to 14 samples per lot. The size of the lot will depend on the particular chemical analysis to be performed and the rate of sampling and chemical analysis. The field sampling effort rate and shipment of samples will be coordinated to ensure that the laboratory capacity and minimum lot size requirements are met.

Blank samples and QC control spike samples will be analyzed along with each lot for all analytes. As required by USATHAMA, when the concentrations of target analytes are greater than the upper limit of the

certified range, the sample or sample extract will be diluted to within the certified range and reanalyzed. All data will be corrected for dilution factors and spike recovery.

The Laboratory QA Coordinator will also assign the QC Control Samples for each lot and monitor the sample analyses to assure compliance with USATHAMA requirements.

7.2.3 HOLDING TIMES

Holding times and preservation requirements for the RMA sampling effort are described in Table 7.2-1. The Project QA Supervisor and Laboratory QA Coordinator will monitor the chemical analysis and sampling effort to assure compliance with USATHAMA holding time and preservation requirements. Any problems will be identified by the Project QA Supervisor to the Site Manager, and the appropriate corrective action will be instituted.

7.2.4 DETECTION LIMITS, ACCURACY, PRECISION, AND CERTIFICATION

The certification status and analytical methods to be used for the analysis of water samples from RMA are given in Table 6.2-1. ESE will be certifying methods for DIMP and DMMP, toluene, benzene, xylene, chloride, and fluoride prior to potable water sampling. Also, all sediment methods will be certified prior to sediment sampling. All methods will be certified as described in Section 4.0 of Appendix A.

The specific USATHAMA requirements for reporting the RMA chemical data are summarized in Table 7.2-2.

7.2.5 ANALYTICAL CONTROLS

Daily QC of the analytical systems ensures that accurate and reproducible results are produced. Careful calibration and the introduction of control samples (control spikes and blanks) are prerequisites for obtaining accurate and reliable results. Both manual and automated data checks will be performed to assure compliance with instrumental and analytical lot QC requirements as specified in Section 4.0 of the ESE Field Laboratory QA Plan.

Table 7.2-1. Sample Containers, Preservation and Holding Times

RMA Migrating Contaminant	Container	Preservation*	Maximum** Holding Time
<u>Extractable Organics</u>			
Aldrin	G, (Amber) Teflon®-lined cap	Cool, 4°C	7 days (until Extraction)
Endrin	"	0.0087% Na ₂ S ₂ O ₃ †	30 days (after Extraction)
Dieldrin	"	"	"
Isodrin	"	"	"
Dicyclopentadiene (DCPD)	"	"	"
Dibromochloropropane (DBCP)	"	"	"
Diisopropylmethylphosphonate (DIMP)	"	"	"
Dimethylmethylphosphonate (DMMP)	"	"	"
P-Chlorophenylmethylsulfone (PCPMSO ₂)	"	"	"
P-Chlorophenylmethylsulfoxide (PCPMSO)	"	"	"
P-Chlorophenylmethylsulfide (PCPMS)	"	"	"
1,4-Diothiane	"	"	"
1,4-Oxathiane	"	"	"
<u>Volatile Organics</u>			
Toluene (MEC ₆ H ₅)	G, (Amber) Teflon®-lined septum cap	Cool, 4°C	14 days
Benzene (C ₆ H ₆)	"	0.008% Na ₂ S ₂ O ₃ †	"
Xylene	"	"	"
Chlorobenzene (CLC ₆ H ₅)	"	"	"
Chloroform (CHCL ₃)	"	"	"
Carbon Tetrachloride (CCL ₄)	"	"	"
trans-1,2-Dichloroethylene (DCE)	"	"	"
Trichloroethylene (TRCLE)	"	"	"
Tetrachloroethylene (TCLEE)	"	"	"
<u>Anions</u>			
Chloride	P	None Required	28 days
Fluoride			

* Polyethylene (P) or Glass (G).

† Samples of drinking water which contain residual chlorine only.

Source: ESE, 1984.

Table 7.2-2 QC Data Reporting Requirements for RMA

Type of Analysis	IR-DMS Requirements
Quantitative	<p data-bbox="868 378 1404 478">Detection Limit: Detection limit obtained during method certification.</p> <p data-bbox="868 510 1429 670">Accuracy: Slope of the least-squares regression line of found-versus-target values for spiked standard or natural samples obtained during certification.</p> <p data-bbox="868 702 1429 893">Precision: Standard error of the estimate of the least-squares regression line of found-versus-target values of spiked standards or natural spikes on the date of analysis.</p>

IR-DMS - Installation Restoration Data Management System.

Source: ESE, 1984.

11/09/84

The Project QA Supervisor will monitor the analytical controls. Failure to pass the instrumental calibration or control sample QC criteria represents an out-of-control situation. Written notification of the QC failure will be provided to the Project Site Manager, and the proper corrective action will be implemented by the Project QA Supervisor.

7.2.6 REVIEWING AND REPORTING REQUIREMENTS

The Project QA Supervisor is responsible for reviewing and approving all field and sampling analytical data before transmittal of data to USATHAMA. ESE, as prime contractor, will review and approve all data processed by MRI. MRI will mail data to ESE lot by lot for the first three lots and then bimonthly thereafter. This data package will include copies of logsheets of sample receipt, analysts' notebook pages, extraction logsheets, raw data; including chromatograms, calibration curves, concentration of standards, calculations, and final data. The QC data (including method blanks, target versus found values from the control spikes, and control charts) will also be submitted. Furthermore, all data transmitted to USATHAMA must be validated by the Project QA Supervisor or validated by his representative and approved by the QA Supervisor. The number of data points validated will be selected based on "Sampling and Procedures and Tables for Inspection of Attributes, Military Standard" (MIL STD-105D, April 19, 1963). As described in Section 3.4.1 of the Management Plan, all chemical data are processed through the USATHAMA Chemical Data Checking Program. Rejected data are corrected and reviewed by the QA Supervisor.

Section 6.0 of Appendix A details the reviewing and reporting functions of the Project QA Supervisor. The formal review and sign-off sheet (Figure 6.1-1 of Appendix A) will accompany all chemical analysis results for each completed Army lot of samples. It is the responsibility of the Project QA Supervisor to check the sign-off sheet periodically to ensure that the review process is complete.

During the active conduct of chemical analyses, the QA Supervisor will submit a QA Program status report upon completion of each analytical lot. As described in Section 5.0 of the Management Plan, this report is

submitted to DMXTH-TE-A and DMXTH-AS. This submittal will include a hard copy of the lot QC charts. All points which indicate an out-of-control situation will be evaluated and explained and necessary corrective action to prevent recurrence described.

8.0 BIOTA MONITORING

Four of the seven direct human exposure pathways involve elements of the biotic environment. Three of these pathways (wildlife, plants, and livestock) are potentially significant because contaminated organisms may be consumed by humans. Investigations of plants and livestock will await the collection of data on the distribution and concentrations of contaminants in the physical environment (e.g. soil, surface water) during Phase I in order to assess the need for and/or more efficiently scope investigation of these pathways during Phase II (see Section 1.2). Basic data will be collected on the wildlife pathway during Phase I because of the mobility of these species in the vicinity of RMA and because contaminant uptake by game species has been demonstrated.

As wildlife species move freely across the boundaries of RMA they pose a potential risk to hunters and their families which may consume contaminated animals. Waterfowl, mourning dove, ring-necked pheasant, and cottontail are game species which can become contaminated on RMA and disperse offpost where they may be shot and consumed by hunters. Waterfowl and mourning dove are migratory species which may become contaminated onpost, but move several hundred miles from RMA. This dispersal makes it less likely that a hunter or group of hunters would consume substantial numbers of contaminated individuals.

Resident species such as ring-necked pheasant and cottontail remain in the vicinity of RMA. Hunting of these species near RMA and subsequent consumption could create a potential human health hazard if several contaminated animals were consumed by an individual, thus increasing the contaminant concentrations in human subjects.

Data on contaminant levels in resident game species on RMA has been documented for the past several years (Thorne, 1982), but data on the movement of these animals on and near RMA is needed in order to determine the offpost distribution of animals which may have become contaminated on RMA.

Cottontails will be studied because of their abundance in habitats on and near RMA and because they may provide a regular food source for some area residents (Ron Howard, Colorado Division of Wildlife (CDOW), pers. comm., April 1984). Ring-necked pheasant will also be investigated because of the potentially higher levels of contaminants in chicks raised on RMA. Because chicks eat large numbers of insects, a higher level in the food chain (Baxter and Wolfe, 1973), they may contain higher contaminant concentrations than adults pheasants or other species which primarily feed on vegetation. As these chicks mature and disperse from the nesting area they may carry significant levels of contaminants offpost.

The home range and seasonal movements of both species will be investigated during Phase I in the northern portion of RMA and in the adjacent offpost study area. These studies are necessary due to the lack of pertinent information on these species in the vicinity of RMA and in the general region. Mark and recapture/resight methods (Lord, 1963) and radiotelemetry will be employed to study cottontails. Radiotelemetry and banding will be used to investigate the movements of pheasants. The field sampling program will be conducted in three phases: 1) a pilot study to define biota study area and evaluate sampling techniques; 2) the capture/marking phase to mark/band individuals and attach radio transmitters to selected individuals; and 3) the monitoring phase where the movement and distribution of individuals are determined.

8.1 PILOT STUDY

A pilot study will be conducted during the spring of 1985 to determine the limits of the biota study area. Potential offpost migration of contaminants via resident wildlife is greatest along the northern and northwestern boundaries of RMA. Habitats on the northern portion of RMA and in adjacent areas of the offpost study area (Figure 1.1-3) will be mapped in order to develop a detailed sampling plan for deployment of traps and transects used to collect and observe pheasants and cottontails. The precise location of distinctive landmarks will also be mapped to provide a guide for determining the location of marked individuals during the monitoring phases.

Some trapping will be conducted in order to test marking techniques and perfect procedures for attaching transmitters. Transmitter range limits will also be tested in order to identify and correct potential problems prior to implementation of the full sampling program. One and two stage transmitters will be tested to determine which will be more suitable for use in tracking cottontails during the monitoring phase. Details of the sampling methods (radiotelemetry and mark recapture/resight) are provided in Section 8.3.

8.2 CAPTURE PHASE

Cottontails and pheasants will be captured and marked during mid-summer of 1985. Annual population levels are highest at this time which is the end of the breeding season, and which precedes population losses due to hunting and natural causes. Both species produce young during the summer which feed in the vicinity of the nest. As the young mature, they disperse from the nesting area during late summer and fall. It is therefore important to mark individuals found on and in the immediate vicinity of RMA prior to this dispersal in order to determine where these potentially contaminated individuals are located during the fall and winter hunting seasons.

Pheasant will be captured using nightlighting procedures (Labisky, 1968). A field vehicle equipped with floodlights will be driven through predetermined portions of the capture area at dusk and during early evening on several nights during the mid-summer. Once an individual is spotted the floodlights are turned off and the driver maintains a strong spotlight on the bird. The combination of engine noise and strong light momentarily confuse the pheasant, allowing the other member of the capture team to collect it using a long-handled net. Nightlighting will also be used to collect some cottontails, but the success rate is lower for rabbits because of their habit of retreating to dense cover in the presence of motor vehicles.

The sex, age, date of capture, and precise location will be recorded for each pheasant captured. Each bird will be individually marked with a non-toxic dye, and selected birds will also be equipped with a

radiotransmitter attached to their back by a harness (Cochran, 1980). Although the number of birds captured will depend on the population density at the time of sampling, a minimum of 10 birds will be equipped with radiotransmitters. Both sexes will be tracked, but young males will be more intensively studied because of their potential for greater dispersal and because legal hunting is restricted to males which are hence the primary pathway for contaminants to humans. Pheasants will also be equipped with reward bands to obtain additional location data and determine the fate of male birds.

The principal capture method for cottontails will be live trapping. Wire mesh traps (Tomahawk collapsible traps 23 x 23 x 81-cm) will be set during the evening and checked early in the morning over a period of four weeks during the mid-summer capture period (July and August, 1985). Traps will be baited and placed in selected locations on the northern portion of RMA and in immediately adjacent offpost areas.

The sex, age, date of capture, and precise location will be recorded for each cottontail. Each rabbit will be individually marked using metal ear tags (Schwartz, 1941) and/or dye methods (Keith et al., 1968). Individuals will be released at point of capture. The date, time, location, and individual identity of animals recaptured or resighted will be recorded for future determination of home range/movement patterns.

8.3 FALL MONITORING

Recapture/resight studies and radiotracking of cottontails and pheasants will be conducted for a total of four weeks during September and October, 1985. Deployment of live traps will be conducted both day and night during periods of favorable weather (absence of precipitation, low wind conditions, and moderate temperatures). Day and night radiotracking surveys will also be conducted, but will not be limited to periods of favorable weather.

Resight studies will consist of driving and walking transects through the biota study area and noting the individual identification and location of observed animals. Collection of individuals during the trapping phase

and subsequent recapture studies will not include onpost areas of potentially high contamination. Data on wildlife movements in these areas may be obtained from radiotelemetry data and/or retrieval of animals found dead in these areas. Locations will be determined from compass sightings to landmarks and established survey markers indicated on maps developed during the pilot study.

Recapture studies of cottontails will require placement of the wire mesh traps used in the summer capture program. Traps will be placed at secure locations throughout the northern portion of RMA and an extensive segment of the offpost study area adjacent to RMA. Locations will be recorded in tabular form and displayed on a map for future calculation of dispersal distances and home range sizes and locations.

Radiotracking will employ a light weight portable TRX 24 receiver equipped with a folding directional antenna which is capable of monitoring up to 48 individuals. Subminiature two stage transmitters with a range of 4.8 to 6.4-km, battery life of 150 days, and weight of 20-22 grams (g) will be mounted on pheasants. Light weight one stage transmitters with a range of 0.8 to 1.2-km will be tested during the pilot study for use on cottontails. Both one and two stage transmitters may be used in cottontails studies, depending on the results of test made during the pilot study. Each transmitter will produce a different radio signal so that individuals can be distinguished without the necessity of visual observation.

8.4 WINTER MONITORING

Winter surveys involving live trapping, resight transects, and radiotracking will be conducted in order to detect possible habitat shifts and/or changes in distribution as a result of winter conditions (Hanson and Progulske, 1973). Winter monitoring will focus on cottontails because cottontail hunting season remains open through February. Individuals which have moved away from the boundaries of RMA during the winter are still subject to hunting and subsequent human consumption.

Approximately three weeks of field surveys will be conducted during January and February, 1986. The same survey methods will be employed as were used during fall surveys. Wire mesh traps will be placed under protective cover so that mortality due to exposure does not occur as a result of severe winter conditions. At the conclusion of field studies radiotracking methods and nightlighting techniques will be used in order to retrieve functional radiotransmitters.

8.5 DATA PROCESSING AND REPORT PREPARATION

Location data from mark and recapture/resight studies and from radiotracking will be compiled in tabular form and graphically displayed to determine maximum and mean dispersal distance and home range size for pheasants and cottontails. A minimum of six observations per individual will be used to compute home range (Stickel, 1950; Wierzbowska, 1975). Data will be analyzed according to age, sex, and season to determine the significance of these variables.

Radiotracking data will be compared with information acquired by mark and recapture/resight methods. Individual home ranges will be mapped to indicate their relationship to potential areas of contamination and to offpost locations. The combined results should produce useful information in determining the potential movement of contaminants off of RMA via resident small game species.

Additional information from existing chemical analyses of resident wildlife collected on and near RMA (Thorne, 1979; Thorne, 1982) and from reward banding may provide some useful information for evaluating potential human risk via the wildlife pathway. Data collected during field studies will be augmented with information from published and unpublished sources and contacts with regional experts to produce the Final Phase I Biota Report.

9.0 CONTAMINATION ASSESSMENT

The primary objective of this work element is the preparation of an exposure assessment. Exposure assessment is the evaluation of the exposure of humans, or other organisms, to environmental contaminants. Environmental criteria developed by the preliminary pollutant limit value (PPLV) Method are used to insure human exposure is within safe limits. Consistent with standard practice in environmental analysis, and in the context of this study, exposure or dosage levels should be traced to their source, or point of release to the ambient environment. Exposure assessment is a tool for evaluating alternative actions intended to reduce exposure to toxicants, and requires tracing the toxicant from source to exposed population (receptors). Actions may be taken at any point along the source-receptor pathway to reduce levels of exposure, so the assessment methodology must provide the flexibility to evaluate actions along the route.

To accomplish these objectives, exposure assessment is comprised of four major components:

1. Source quantification,
2. Contaminant fate and transport,
3. Distribution and behavior of exposed population, and
4. Evaluation of exposure mechanisms.

At RMA, sources are relatively well-quantified. In the context of the offpost contamination assessment, evaluation of many proposed alternative actions may permit consideration of the arsenal boundary as the "sources". Such an approach would not be effective in evaluating source-specific controls such as capping of Basin A or Basin F. In the context of the offpost assessment, however, it will still be useful to consider the boundary as the source, while relying on other onsite-studies to quantify the "boundary effect" of a source control.

Source quantification will primarily be identified by evaluating water chemistry results along the boundary. The evaluation will include lateral quantification along the north and northwest boundaries with a

comparison to background water chemistry. Background water chemistry will be determined by evaluating shallow ground water chemistry samples collected along the south and southeast boundaries.

Zone of contamination leaving RMA will be identified by analyte transport pathway, method of transport (biota, water) and magnitude of the analyte to zones of contamination will be affected by the efficiency of the remedial action programs already instituted. The effectiveness of these remedial action programs will be determined by reviewing the changes in the hydrologic system over the period in which reliable hydrologic data and procedural data exist.

The contaminant fate and transport feature of the offpost exposure assessment will ultimately rely on the distribution of hydrologic data and the use of some sort of environmental model. The evaluation of collected data and to some extent previously available data, will focus on the distribution, magnitude and mobility of pollutants in the ground water system. The evaluation will identify the distribution of analytes in each previously determined pathway (i.e., First Creek or Second Creek). Unexplained cases of pollutants being detected outside of the anticipated migration pathways will be reviewed to determine the probable origin of the anomaly and its impact on the assumed distribution of contaminants and their expected transport method.

Hydrologic properties of surficial and bedrock materials will be evaluated to determine the mechanisms by which contaminants are mobilized and transported throughout the hydrologic system associated with this study. The magnitude of contamination in relation to its areal extent will be determined mathematically by evaluating the chemical distribution of contaminants. In the study area, constituents will be contoured and their probable mobility identified. Hydrologic test data will be analyzed to determine the local variability of permeabilities, gradient and saturated thickness of the saturated zone.

Review of soil samples will help in the identification of the fate of contaminants in the system. Mobility of the contaminants will depend on

the hydraulic interaction of soil particles with each individual contaminant. The duration of each contaminant will depend on the chemical and hydraulic interaction of each contaminant.

Since exposure assessments are usually predictive, the distribution of exposed populations must often account for expected changes in land use, growth, etc. Exposure assessment implicitly concludes that environmental contamination is not harmful unless someone or something is exposed to this contamination. For example, contamination of unused and of unusable aquifers would not result in exposure. Thus, probable exposure mechanisms, e.g., ingestion of contaminated well water or inhalation of contaminated air should be quantified.

To be effective (particularly cost-effective), an exposure assessment must focus quickly on the dominant exposure pathways. This requires careful planning and review of available data to hypothesize the dominant pathways and critical uncertainties in each pathway to focus further investigation.

Health criteria studies and investigations of contaminant pathways during Phase I will be integrated to produce a preliminary exposure assessment. Data on the extent, distribution, and identification of offsite contaminants will be evaluated in order to determine what, if any, additional information will be required to develop adequate remedial action plans. This additional information (if required) will be gathered during Phase II and used in a more detailed exposure assessment prior to the development of remedial action plans.

10.0 REPORT PRODUCTION

This element consists of the activity required to produce all written deliverables. The project schedule calls for the preparation of the following administrative and technical reports.

10.1 ADMINISTRATIVE REPORTS

These reports include:

1. Performance of Cost Report--will be required on a monthly basis and submitted to USATHAMA within 10 working days after the completion of each project month.
2. Contractor's Progress and Status Report--this report is due on a monthly basis following completion of each project month. It will be the responsibility of the Project Manager to initiate a telephone call to USATHAMA on the progress and status of the project to date.
3. Progress Status Meeting Report--these reports will be required following the initiation of a meeting. This report will be submitted to USATHAMA within 5 working days after the scheduled meeting.

10.2 TECHNICAL REPORTS

These reports include:

1. Consumptive Use Water Sampling and Exposure Assessment Report--this report will be submitted after the completion of the consumptive use water sampling effort.
2. Augmentation Report--this report will be submitted to refine the distribution of the anticipated installation of 30 monitor wells throughout the study area. This report will identify any revisions required to the technical and management plans derived from the additional information gathered during consumptive use sampling effort.
3. Preliminary Contamination Assessment Report--this report will be submitted to USATHAMA after the completion of the first quarterly ground water, surface water/sediment sampling effort.

4. Contamination Assessment II Final Report--this report will be a comprehensive program review report which will be submitted to USATHAMA upon completion of all sampling activities. This report will be delivered at the completion of the project, after all field studies have been completed.

The technical and administrative reports required for this project will be prepared using ESE's document production facilities. These facilities include:

- o Dictaphone 6000 Word Processors with Full Communication Links;
- o Kenro 241 Mark II Vertical Process Camera;
- o Compugraphic Editwriter; and
- o Canon 400 Automatic Feed Copier.

ESE's Document Coordinator will be responsible for the production of project copy deliverables which include technical and administrative reports. The Document Coordinator will be responsible for report formats, editing for clarity and consistency; coordination among technical authors and project management; coordination of graphics production; coordination with USATHAMA editing staff regarding report structure; and report printing and distribution.

All reports will conform with USATHAMA formats following MIL-STD-847A guidelines and Government Printing Office Style Manual, 1973.

10.3 REPORT QUALITY ASSURANCE/QUALITY CONTROL

All project deliverables will be reviewed by a qualified individual for QA/QC. The Denver regional office will maintain a technical peer review system for project deliverables. The Regional Office Manager will be responsible for enforcement of the peer review process, and subject to periodic audit by the QA Manager. The primary record of this peer review process is a QC deliverable review sheet. A copy of the completed deliverable review sheet (Figure 10.3-1) must be maintained by the Project Manager for his project deliverables. The peer review process is audited and coordinated by the ESE QA Manager.

BIBLIOGRAPHY
(Page 1 of 3)

- Baxter, W.L. and C.W. Wolfe. 1973. Life History and Ecology of the Ring-necked Pheasant in Nebraska. Nebraska Game and Parks Comm., Lincoln, Nebraska.
- Black, J.H. 1978. The Use of the Slug Test in Ground Water Investigations. Water Services, 82(985):174-178.
- Boulton, N.S. and Streltsova, T.D. 1976. The Drawdown Near an Abstraction Well of Large Diameter Under Non-Steady Conditions in an Unconfined Aquifer. Journal of Hydrology, 30:29-26.
- Bouwer, H. and Rice, R.C. 1976. A Slug Test for Determining Hydraulic Conductivity of Unconfined Aquifers with Completely or Partially Penetrating Wells. Water Resources Research, 12(3):423.
- Cooper, H.H., Bredehoeft, J.D., and Papadopulos, I.S., 1967. Response of a Finite-Diameter Well to an Instantaneous Charge of Water. USGS, Water Resources Research, 3(1). Washington, D.C.
- Cochran, W.W. 1980. Wildlife Telemetry. In S.D. Shemnitz (ed.). Wildlife Management Techniques Manual. The Wildlife Soc., Washington, D.C.
- ESE, 1984. Rocky Mountain Arsenal Offpost Contamination Assessment Concept Plan - Draft Final Report.
- Hanson, L.E. and Progulske, D.R. 1973. Movement and Cover Preferences of Pheasants in South Dakota. Journal Wildlife Management. 37(4):454-461.
- Hvorslev, M.J. 1951. Time Lag and Soil Permeability in Ground Water Observations. Bulletin No. 36. Waterways Experiment Station. Corps of Engineers, U.S. Army. Vicksburg, Mississippi.
- Keith, B.B., Meslow, E.C., and Rongstad, O.J. 1968. Techniques for Snowshoe Hare Population Studies. J. Wildlife Mgmt. 32:801-812.
- Labisky, R.F. 1968. Nightlighting: Its Use in Capturing Pheasants, Prairie Chickens, Bobwhites, and Cottontails. Biol. Notes No. 62, Illinois Nat. Hist. Survey, Urbana, Illinois.
- Little, A.D. 1982. Problem Definition Study on Selected Chemicals. Volume IV. Site Specific Evaluation of Selected Organic Pollutants at Rocky Mountain Arsenal, Final Report. A.D. Little, Inc., Cambridge, MA. DAMD 17-77-C-7037.
- Lord, R.D. 1963. The Cottontail Rabbit in Illinois. Ill. Dept. Conservation Tech. Bull. No. 3.

BIBLIOGRAPHY
(Continued, Page 2 of 3)

- Robson, S.G. and Romero, J.C. 1981. Geologic Structure, Hydrology, and Water Quality of the Denver Aquifer in the Denver Basin, Colorado. USGS HA#646.
- Rocky Mountain Arsenal (RMA). 1983. Installation Restoration at Rocky Mountain Arsenal: Selection of a Contamination Control Strategy for RMA Volume I and II. Final Report Prepared for: USATHAMA and RMA. DRXTH-SE-83206.
- Rosenblatt, D.H. 1975. Problem Definition Study on Potential Environmental Pollutants: Vol. I, Toxicology and Ecological Hazards of 16 Substances at Rocky Mountain Arsenal, and Vol. II, Physical, Chemical, Toxicological, and Biological Properties of 16 Substances. USAMBRDL, Fort Detrick, MD. Technical Reports 7508 and 7509.
- Rosenblatt, D.H. 1983. Application of the Preliminary Pollutant Limit Value (PPLV) Environmental Risk Assessment Approach to Selected Land Uses. Chapter 14. In: Fate of Chemicals in the Environment, R.L. Swann and A. Eschenroeder, Eds. Symposium Series 225, American Chemical Society, Washington, D.C.
- Schwartz, E.W. 1941. Home Range of the Cottontail in Central Missouri. J. Mammalogy. 22(4):386-392.
- South Adams County Water and Sanitation District (SACWSD). 1983. Preliminary Assessment Report.
- SACWSD. 1984. Draft Sampling Plan for South Adams County Water and Sanitation District, Commerce City, Colorado.
- Spaine, P.A., Thompson, D.W., and Dildine, J.H. 1983. Regional Ground Water Study of RMA, Report 2: Contamination Distribution. July, 1983. Ground Water and Surface Water S&A Methods.
- Stickel, L.F. 1950. Populations and Home Range Relationships of the Box Turtle, Terrapene c. carolina (Linnaeus). Ecol. Monogr. 20(4):351-378.
- Thorne, D.S. 1979. Biological Monitoring of Pesticides, Heavy Metals, and Other Contaminants at RMA, Phase I. July, 1979.
- Thorne, D.S. 1982. Contaminants in Fish and Game Animals on Rocky Mountain Arsenal 1977-1982. Rocky Mountain Arsenal Information Center, Commerce City, Colorado.
- USAEHA. 1981. Ambient Air Quality Assessment #43-21-0170-81, Rocky Mountain Arsenal, Denver, Colorado. June, 1981.
- USATHAMA. 1983. Geotechnical Requirements for Drilling, Monitor Wells, Data Acquisition, and Reports. Aberdeen Proving Ground, MD.

BIBLIOGRAPHY
(Continued, Page 3 of 3)

- USATHAMA. 1984. Installation Restoration (IR) Data Management User's Guide Version 84.1. Edgewood, MD.
- Walton, W.C. 1978. Comprehensive Analysis of Water Table Aquifer Test Data. Ground Water, 16(5):311.
- Wierzbowska, T. 1975. Review of Methods for Estimating the Parameters of Home Range of Small Forest Rodents from the Aspect of Sample Size. Acta Theriologica (20(1):3-22.

APPENDIX A

ESE FIELD LABORATORY AND QUALITY ASSURANCE PROGRAM PLAN

APPENDIX A
ESE FIELD LABORATORY QUALITY ASSURANCE PROGRAM PLAN

TABLE OF CONTENTS

<u>Section</u>		<u>Page</u>
1.0	INTRODUCTION	A-1-1
2.0	RESPONSIBILITIES FOR QA	A-2-1
2.1	<u>OVERALL PLAN FUNCTION</u>	A-2-1
2.2	<u>QA/QC RESPONSIBILITIES</u>	A-2-3
	2.2.1 USATHAMA CENTRAL LABORATORY QA COORDINATOR	A-2-3
	2.2.2 ESE PROJECT QA SUPERVISOR	A-2-5
	2.2.3 ESE SITE MANAGER	A-2-7
	2.2.4 CHEMICAL ANALYSIS SUPERVISOR	A-2-7
	2.2.5 ESE ANALYTICAL OR FIELD TEAM LEADER	A-2-7
	2.2.6 ESE ANALYSTS AND SAMPLING PERSONNEL	A-2-7
3.0	ANALYTICAL SYSTEMS CONTROLS	A-3-1
3.1	<u>SAMPLE MANAGEMENT</u>	A-3-1
3.2	<u>SAMPLING</u>	A-3-3
	3.2.1 VOLATILES	A-3-4
	3.2.2 GROUND WATER	A-3-8
	3.2.3 SURFACE WATER	A-3-9
	3.2.4 AIR	A-3-10
	3.2.5 SOIL	A-3-11
	3.2.6 SEDIMENTS	A-3-11
3.3	<u>SAMPLE PRESERVATION</u>	A-3-13
3.4	<u>SAMPLE PREPARATION</u>	A-3-19
	3.4.1 WATER SAMPLES	A-3-19
	3.4.2 SOIL SAMPLES	A-3-20
	3.4.3 SEDIMENT SAMPLES	A-3-20
	3.4.4 STANDARD SAMPLES	A-3-21
3.5	<u>SUBSAMPLING</u>	A-3-21
3.6	<u>CONTROL SAMPLES</u>	A-3-21
3.7	<u>REFERENCE MATERIALS</u>	A-3-21

APPENDIX A
ESE FIELD LABORATORY QUALITY ASSURANCE PROGRAM PLAN

TABLE OF CONTENTS
(Continued, Page 2 of 2)

<u>Section</u>		<u>Page</u>
3.8	<u>ANALYTICAL METHODS AND CERTIFICATION</u>	A-3-22
	3.8.1 RATIONALE	A-3-22
	3.8.2 METHOD CERTIFICATION	A-3-23
3.9	<u>ANALYST CERTIFICATION</u>	A-3-26
4.0	ANALYSIS OF SAMPLES	A-4-1
4.1	<u>LABORATORY INSTRUMENTAL QC CONTROLS</u>	A-4-1
4.2	<u>CONTROL SAMPLES</u>	A-4-3
5.0	INSTRUMENT CALIBRATION AND MAINTENANCE	A-5-1
5.1	<u>FIELD INSTRUMENT CALIBRATION</u>	A-5-3
5.2	<u>ANALYTICAL NOTEBOOKS AND INSTRUMENT LOGBOOKS</u>	A-5-3
5.3	<u>SPECIFIC ANALYTICAL SYSTEMS CONTROL</u>	A-5-5
	5.3.1 METALS SYSTEM CONTROL	A-5-5
	5.3.2 NITRITE PLUS NITRATE, SULFATE, AND PHOSPHATE ANALYSES	A-5-6
	5.3.3 GC ANALYSIS	A-5-6
	5.3.4 GC/MS ANALYSIS	A-5-7
6.0	AUDITING AND REPORTING OF DATA	A-6-1
6.1	<u>SEMIQUANTITATIVE ANALYSES</u>	A-6-1
6.2	<u>QUANTITATIVE ANALYSES</u>	A-6-3
REFERENCES		A-Bib-1

LIST OF TABLES

<u>Table</u>		<u>Page</u>
3.3-1	Containers, Preservation, and Holding Times	A-3-14
3.3-2	Sample Container Cleaning Procedures	A-3-17
4.1-1	Summary of Instrumental Systems Control Requirements	A-4-2
4.2-2	QC Requirements by Sample Lot	A-4-4

LIST OF FIGURES

<u>Figure</u>		<u>Page</u>
2.1-1	Laboratory QA/QC Organization and Function	A-2-2
2.1-2	Field QA/QC Plan Organization and Function	A-2-4
3.2-1	USATHAMA Field Sampling Audit Checklist	A-3-5
3.2-2	Surface Soil Composite Sampling Method	A-3-12
3.9-1	Typical Certification Audit Page	A-3-27
6.1-1	Army Data Review Form	A-6-2

1.0 INTRODUCTION

This document is the overall Project Quality Control (QC) Plan for sampling and analyses performed during environmental survey tasks assigned under the Multi-Installation Eastern Sites Environmental Survey Contract (DAAK11-83-D-0007). This plan complies with the U.S. Army Toxic and Hazardous Materials Agency (USATHAMA) Quality Assurance (QA) Program. Specific details and deviations from this general plan, if any, for a certain task or survey will be described in detail in the Task Sampling and Analysis Plan. Because of the detailed nature of the USATHAMA QA Program Plan, this Project QC Plan includes sections that are very similar to those in the USATHAMA QA Program Plan.

The specific objectives of this plan are to describe in general detail the processes for controlling the validity of the data generated in the sampling and analysis efforts; the methods and criteria for detection of out-of-control situations; steps to be taken to provide timely corrective action; and how such actions will be reported and documented. The Project QA Plan also supports the Data Management Plan by providing documentation of the limits of precision, accuracy, and sensitivity of all analytical systems generating data and by providing mechanisms for documentation of the validity of all reported data.

Some environmental surveys and other tasks assigned under this contract may require the development and documentation of certain semiquantitative and quantitative analytical methods for all phases of the project. The analytical systems controls and data validation procedures described in this QC Plan will be employed to ensure valid, properly formatted data defining the precision, accuracy, and sensitivity of each method.

2.0 RESPONSIBILITIES FOR QA

The QC Plan functions according to the USATHAMA central-laboratory/field-laboratory concept. Environmental Science and Engineering, Inc. (ESE) acts as the field laboratory, which is monitored by the USATHAMA Central Laboratory QA Coordinator. The overall QA/QC organization to provide valid data to the Commander of USATHAMA is shown in Fig. 2.1-1. The function of the plan and QA responsibilities of each of the project participants are outlined in the following subsections.

2.1 OVERALL PLAN FUNCTION

Fig. 2.1-1 depicts the manner in which the ESE Project QA Supervisor monitors the conduct of the sampling and analytical effort. In this position, the QA Supervisor is not directly subordinate to anyone responsible for sampling and analysis; the supervisor reports to the ESE Project Manager and the USATHAMA Central Laboratory QA Coordinator. Within the flow of the project scheme, the QA Supervisor controls the receipt of samples, organizes the samples into analytical lots, ensures that appropriate QC samples are included, and supervises any necessary subsampling. The specific responsibilities of the QA Supervisor are detailed in Par. 2.2.2.

The analyst performs the analyses and preliminary QC checks and submits results to the Analytical Team Leaders for approval. The Data Assistant enters the data into the ESE data handling system, preprogrammed QC checks are run, and a printout is generated. The QA Supervisor monitors the QC results, approves results which are in control, and updates QC criteria and control charts. At this point, any analytical problems and out-of-control situations are identified by the QA Supervisor and corrective action is recommended. Subsequently, data are reviewed by the ESE Project Manager within the overall context of the sampling and

analysis program. If questions are encountered, they are resolved before further data processing.

Approved data are transcribed into the U.S. Army format and entered at Level 1. The Project QA Supervisor validates the Level 1 data by verifying the accuracy of the analysis and transcription of a data subsample. This is represented in Fig. 2.1-1 by the dotted lines passing back from the validation step to the sample. Military Standard (MIL-STD)-105D for inspection of sampling procedures and tables by attributes is used to validate Level 1 data.

The manner in which the Project QA Supervisor monitors the field effort is shown in Fig. 2.1-2. This figure shows that the Project QA Supervisor monitors the logging-in of samples, checks copies of field notebook entries and logsheets, and reports any inconsistencies and/or omissions to the Field Team Leader. The QA Supervisor also monitors the QC and calibration data submitted to support field tests and analysis.

The field data will consist of three types of data files: (1) the field drilling file, (2) the ground water stabilized file, and (3) the map file. In addition, certain field sampling information must be collected and entered into the chemical data files.

Field data which have passed the QC checks are passed to the Data Assistant for direct entry to the U.S. Army system via the Tektronix 4051. Validation of field data is performed by the QA Supervisor in the same manner as for laboratory results.

2.2 QA/QC RESPONSIBILITIES

2.2.1 USATHAMA CENTRAL LABORATORY QA COORDINATOR

The Central QA Laboratory will monitor the QA/QC activities of the field laboratory to ensure the quality of the generated data. The USATHAMA

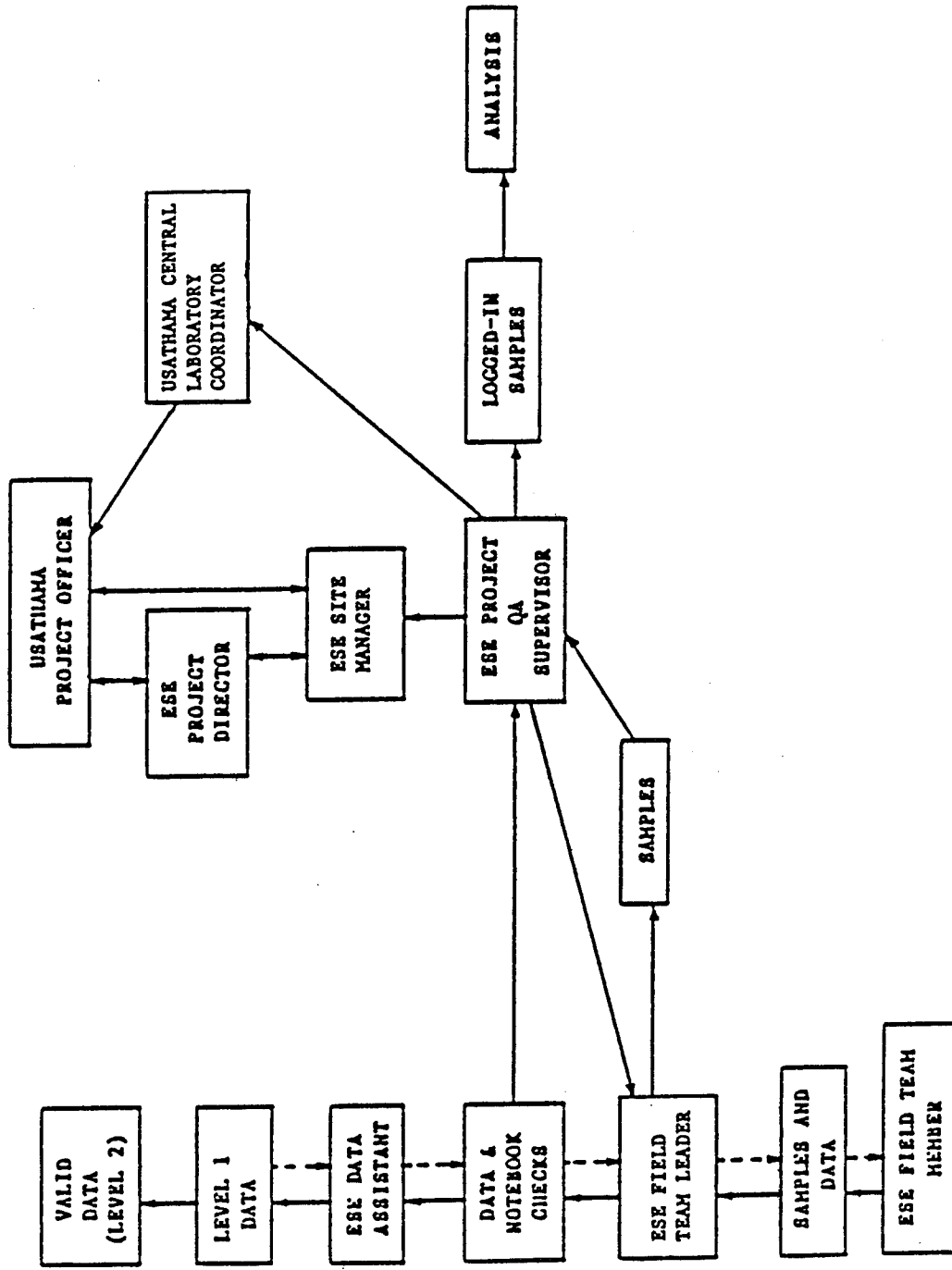

Prepared for:
 U.S. Army Toxic and Hazardous
 Materials Agency
 Aberdeen Proving Ground, Maryland

Figure 2.1-2
 FIELD QA/QC PLAN
 ORGANIZATION AND FUNCTION

Central Laboratory QA Coordinator therefore has the following responsibilities in fulfilling this objective:

1. Provide technical evaluations of QC plans submitted by performers, as required. QC plans are to be developed according to this USATHAMA QA Program.
2. Provide technical evaluations of laboratory facilities and capabilities, as required.
3. Manage the QA activities required for the preparation of standards and the evaluation of methods.
4. Maintain the analytical reference material repository.
5. Provide analytical reference materials with supporting documentation to field laboratories.
6. Notify the Field Laboratory Chief, USATHAMA Project Officer, and Analytical Branch when a situation exists at a field laboratory that precludes statistical control of results.
7. Provide a systematic review of how the USATHAMA QA Program is being implemented at each field laboratory by conducting visits to the field laboratory and reporting the findings to the USATHAMA Analytical Branch and Project Officer.
8. Provide QC samples and data analysis program tapes to field laboratories.

2.2.2 ESE PROJECT QA SUPERVISOR

The ESE Project QA Supervisor is responsible to the ESE Site Manager and the USATHAMA Central Laboratory QA Coordinator to monitor and document the quality of all data reported to USATHAMA. The supervisor's specific responsibilities are:

1. To provide an independent overview of the QC practices of the Project Team from the beginning of the project through acceptance of the final report, to ensure that the team completes all QC requirements of the project plan;
2. To maintain and review all QC records, including control charts, and to provide copies of QC records to USATHAMA on a weekly basis:

3. To prepare those sections of all interim and final project reports dealing with QC data;
4. To establish testing lots (batches) in coordination with the Analytical Team Leader and/or Site Manager and to introduce appropriate control samples in each lot;
5. To monitor the logging-in of samples, as well as sample preservation, handling, subsampling, and transport throughout the project;
6. To audit data files for correct entry of all data and approve all data before transmittal to Level 2;
7. To obtain and maintain records on Standard Analytical Reference Material (SARM) or interim reference materials;
8. To establish and maintain liaison between the ESE Project Team and the USATHAMA Central QA Coordinator;
9. To maintain a vigil of the entire laboratory and field operation to detect conditions which might jeopardize control of the various analytical and sampling systems;
10. To ensure by field visits that appropriate sampling, field testing, and field analysis procedures are followed and that correct QC checks are being made;
11. To inform the ESE project management and the USATHAMA Central QA Coordinator concerning nonconformance with the QA program and provide documentation of said nonconformance, to recommend the corrective actions that are to be taken, and to document their completion;
12. To maintain and update records of the qualifications of the analysts and field team members; and
13. To update QA/QC procedures as new developments occur. This includes new developments in the QA/QC field and specifically any proposed changes in the project QA Plan. Any proposed revisions will be approved by both ESE project management and the USATHAMA Central QA Coordinator and Project Officer.

2.2.3 ESE SITE MANAGER

The ESE Site Manager is responsible for effective day-to-day management of the total project staff, as well as direct communication and liaison with the USATHAMA Project Officer. The Site Manager's responsibility specific to QA/QC is to approve all QA/QC procedures to be used in the conduct of the project, to provide additional authority when required to support the ESE Project QA Supervisor, and to approve of any revisions to the project QC Plan.

2.2.4 CHEMICAL ANALYSIS SUPERVISOR

The Project Chemical Analysis Supervisor is responsible for effective day-to-day coordination of all USATHAMA analytical activity. The Chemical Analysis Supervisor's QA/QC responsibility is to provide guidance and technical support in resolution of QC problems; to support QA/QC preparation of control samples; and to provide guidance in preparation of analytical lots to ensure efficient, comprehensive analysis of all required parameters. This supervisor also provides additional authority, when needed, to support the QA Supervisor in analytical matters and must approve all revisions of the QC Plan regarding analytical activities.

2.2.5 ESE ANALYTICAL OR FIELD TEAM LEADER

ESE Team Leaders are responsible for provision of accurate field or laboratory data produced by analysts and sampling personnel under their supervision. They are responsible to the ESE Project QA Supervisor to ensure that all QC procedures are followed and documentation provided. The QA role of the Team Leader is, therefore, to assist the QA Supervisor in enforcing QA/QC procedures.

2.2.6 ESE ANALYSTS AND SAMPLING PERSONNEL

It is the responsibility of the analysts and field team members to perform the required QA/QC procedures and to document all observations in logbooks in permanent ink. It is the responsibility of the analyst to perform preliminary QC checks to ensure that each batch of data being

generated meets all analytical criteria. The field team member or analyst must also bring any unusual observation or analytical problem to the immediate attention of his/her Team Leader or the ESE Project QA Supervisor.

Each analyst is responsible for ensuring that sufficient quantities of reagents of adequate quality are available for the performance of the required analyses.

3.0 ANALYTICAL SYSTEMS CONTROLS

3.1 SAMPLE MANAGEMENT

A critical step in the processing of samples involves the initial check-in and preparation for analysis. Proper chain-of-custody, efficient processing to meet holding times, and avoidance of cross-contamination are vital to the integrity of the final data. ESE's sample management and data management systems are integrated into ESE's Chemical Laboratory Analysis and Scheduling System (ESE-CLASS), which is fully described in the Project Data Management Plan.

Samples are received by the Chemical Analysis Supervisor. They are unpacked and the logsheets compared with the contents. Samples are scheduled for processing, and the log sheets are given to the Data Management Coordinator, who activates the sample numbers for analysis. Army lot designations and printouts are generated with updated site identifications (IDs) and sample dates. If any sample processing is required, it will take place immediately.

Sample log-in at the laboratory will be monitored by the QA Supervisor. The QA Supervisor signs the computer logsheet after verification of complete conformance of the log to the sample set and verification of the information contained on the sample labels. Any inconsistencies or unusual circumstances, such as broken or leaking containers, improper preservation, or noncompliance with holding or shipping requirements will be identified in writing to the ESE Site Manager and the Field Team Leader. Corrective action will be recommended and approved by the ESE Site Manager and the USATHAMA Project Officer. When such corrective action involves resampling, this activity may occur based on ESE Project Manager approval, only to expedite the field effort.

Establishment of Army lots will be performed by the Project QA Supervisor after the samples have been logged into the ESE computerized data management system. The QA Supervisor will place samples into analytical lots based on analysis and sample matrix type. The number of samples per lot will depend on the number of samples which can be conveniently and efficiently analyzed as a group. The factors which will be taken into consideration in establishing lot size include: (1) the type of analysis; (2) the analysis complexity; (3) the holding time for the sample; and (4) the time constraints imposed by well development, sampling, and shipping considerations. The batch lot will be optimized to provide efficient analysis while meeting the holding time criteria for the samples.

The anticipated minimum lot size for sample analysis will be 10 samples. Smaller lot sizes may be necessary due to the limited number of samples being collected at any particular installation, especially complex sample analysis or extraction procedures, or holding time constraints. Every attempt will be made to maximize the number of samples per lot.

The following QA procedures will be implemented to monitor sample management. The management of samples, up through the point of designating the aliquot to be analyzed, is under the supervision of the QA Supervisor.

- The QA Supervisor will make a trip to each site to inspect the sampling. The QA Supervisor will document the sampling procedures and ensure that procedures described in the scope of work are followed.
- The QA Supervisor will ensure that samples are being labeled, preserved, stored, and transported according to the prescribed methods.
- If the QA Supervisor determines that significant deviations from the sampling protocol have occurred, resulting in a compromise of the sample integrity, all samples taken prior to the inspection,

subsequent to any previous inspection, will be discarded and fresh samples taken.

- The QA Supervisor will introduce control samples (duplicates, spikes, and blanks) into the sample flow in an inconspicuous fashion.
- The QA Supervisor will assign internal laboratory identification numbers to all incoming samples and QC samples. The identification numbers will be sequential and will be maintained in a bound logbook to associate the number with the sample. During the assignment of the internal identification numbers, the Project QA Supervisor will establish the sample lots and sample order within each lot ensuring that QC samples are included within each lot. Identification numbers within a lot will be sequential.

3.2 SAMPLING

This section describes the QC procedures to be followed during environmental matrix sampling. To ensure samples representative of the system under study, samples must be collected in properly cleaned containers, promptly and properly preserved, and transported to the laboratory in a manner which minimizes the chance for significant change in constituents. The type of sample (grab, composite, etc.) and the location rationale of the sample point are described in the task Technical Plan. Proven sampling, preservation, and shipping methods which comply with USATHAMA and U.S. Environmental Protection Agency (EPA) specifications will be used to the extent possible. The Field Team Leader is responsible for proper sample collection, documentation, preservation, and shipment. The QA Supervisor controls the receipt of samples, audits the field sampling procedures, and monitors compliance with preservation and holding time specifications.

At least one site visit will be performed by the QA Supervisor during each sampling effort to audit sampling performance. The QA Supervisor may require new samples to be collected if the sample collection

procedures are unsatisfactory. Fig. 3.2-1 shows an example of the USATHAMA Field Sampling Audit Checklist, which should be filled out by the QA Supervisor during the site visit.

Pre-printed field notebooks will be made available to sampling personnel. Notebook pages will describe all the information that is required and the format that is consistent with entry into Installation Restoration Data Management System (IR-DMS). Many qualitative observations (e.g., sketches) that cannot be entered into IR-DMS and that must be used for preparation of later project reports should be retained in permanent record.

Field notebooks will be reviewed and signed by the appropriate Field Team Leader on a daily basis and reviewed by the QA Supervisor at the end of the sampling effort to ensure that each page is accurate, understandable, and complete. A copy of the computerized sample logsheet will accompany the samples as a part of the chain-of-custody record.

The following QC practices (consistent with the USATHAMA QA Program) will be used during field sampling

3.2.1 VOLATILES

Air sampling for volatile compounds is highly dependent on sampling time, flow rate, and collection device. The collection procedure is considered an integral part of the analytical method for air samples and will be included in the method documentation.

Loss of volatile compounds from water samples can occur through evaporation. Care should be taken to preclude aeration of the sample with any gas, to fill bottles completely with the samples allowing no air space, and to analyze within the specified holding times.

Section Number 6
Revision Number 1
Date of Revision 11/6/80

Project _____ Project Number _____
Date _____ Auditor _____
Project Location _____ Title of Auditor _____

Item	Yes/No	Comment
1. Does each member of the field team clearly understand his/her role and position in both the project and field team structure?		
2. Has a Field Sampling Plan been filed in the proper manner?		
3. Does each team have in its possession a copy of the Sampling and Analysis Plan and Section 6.0 of the QA Plan?		
4. Is a permanent field notebook being kept?		
5. Does the notebook contain all required information?		
6. Has the Field Team Leader signed all pages in the notebook at the end of each day?		
7. Has all field instrument calibration information been placed in the notebook?		
8. Are samples taken from representative locations?		

Figure 3.2-1
USATHAMA FIELD SAMPLING
AUDIT CHECKLIST
(Page 1 of 3)

Prepared for:
U.S. Army Toxic and Hazardous
Materials Agency
Aberdeen Proving Ground, Maryland

Section Number 6
Revision Number 1
Date of Revision 11/6/80

Item	Yes/No	Comment
9. Does the field team have a copy of detailed calibration and operation instructions for every instrument?		
10. Are instruments properly calibrated at least daily?		
11. Are replicate samples taken at 10 percent of the sample sites?		
12. Are samples preserved in the proper manner?		
13. Are sample containers appropriate for the parameters to be studied?		
14. Are preservative acids and reagents of known, high purity and appropriate for the analysis?		
15. Are samples shipped so that they arrive at the laboratory within holding times?		
16. Are labels with all required information affixed to each sample container?		
17. Has back-up identification of each sample container been made?		
18. Are proper preservation codes used on the sample labels?		

Figure 3.2-1
USATHAMA FIELD SAMPLING
AUDIT CHECKLIST
(Page 2 of 3)

Prepared for:
U.S. Army Toxic and Hazardous
Materials Agency
Aberdeen Proving Ground, Maryland

Section Number 6
Revision Number 1
Date of Revision 11/6/80

Item	Yes/No	Comment
19. Has a standard shipping form been included in <u>each</u> package?		
20. Are samples properly logged in on arrival at the lab?		
21. Are the samples collected in a safe and legal manner?		
22. Were field instrumentation and supplies properly requested?		
23. Have a Receiving Clerk and alternates been appointed?		

Source: Environmental Science and Engineering, Inc., 1980.

Figure 3.2-1
USATHAMA FIELD SAMPLING
AUDIT CHECKLIST
(Page 3 of 3)

Prepared for:
U.S. Army Toxic and Hazardous
Materials Agency
Aberdeen Proving Ground, Maryland

Analyses for volatiles in soils and sediments are not normally performed in USATHAMA programs, since the required sample handling (drying and homogenation) presents an opportunity for analyte loss.

3.2.2 GROUND WATER

Ground water sampling should not be performed until after newly installed monitor wells have been allowed to reach equilibrium (no less than 14 days after well development). All observations and pertinent data developed during ground water sampling will be recorded in a field notebook similar to the field notebook used for surface water sampling (see Sec. 3.2.3). The following procedures will be followed on each sampling day.

1. The depth to water will be measured and recorded in the field notebook.
2. Samples will be taken after the fluid in the screen, well casing, and annulus has been exchanged five times. The amount of fluid exchanged will be measured and recorded in the field notebook. All sampling will be accomplished by a dedicated bailer constructed of polyvinyl chloride (PVC). No glue will be used in the construction of these bailers.
3. To protect the wells from contamination during sampling procedures, the following guidelines will be followed.
 - a. A separate bailer will be supplied for, and attached to, each well. This bailer will remain in place in the well during the monitoring phases.
 - b. When a pump is used to purge the standing water from the well, the pump and associated hoses will be thoroughly cleaned between the samples using water from an approved source.
 - c. All sampling equipment will be placed on disposable polyethylene plastic sheeting spread on the ground at the well to prevent soil contamination from tainting the ground water samples.

4. The sample will be collected in a manner which will minimize its aeration and prevent oxidation of reduced compounds in the sample. The container will be filled to overflowing without air bubbles and tightly capped.
5. Samples for metal analyses will be vacuum filtered in the field through a 0.45-micron (u) filter, chilled to 4 degrees Celsius (°C), appropriately preserved, and immediately transported to the laboratory.
6. Each sample bottle and cap will be rinsed with a minimum of 25 milliliters (ml) of filtered (0.45-u filter) water from the well at the time of sampling.
7. Onsite measurements of water quality will include conductivity, pH, and temperature. Calibration standards will be run prior to each set of measurements.

3.2.3 SURFACE WATER

Prior to surface water sampling, the following data will be noted and recorded in the field notebook:

1. Site number or location;
2. Date;
3. Time (24-hour system);
4. Antecedent weather conditions, if known;
5. In situ parameter measurements;
6. Fractions and preservatives;
7. Any other pertinent observations (odor, fish, etc.); and
8. Signature of sampler and date.

At the conclusion of each day in the field, the Field Team Leader will review each page of the notebook for errors and omissions. He/she will then date and sign each reviewed page.

All field instrument calibrations will be recorded in a designated portion of the notebook at the time of the calibration. Adverse trends in instrument calibration behavior will be corrected.

A single mid-current sampling point will be used for most streams where lateral mixing is complete. Sampling will take place at approximately 1/2 to 2/3 of the water depth at its deepest point.

Sampling the edge of a stream from the bank will be avoided if possible. If unavoidable, sampling will be on the outside of a bend where the current flows along the bank. This will avoid collection of quiet or even stagnant water of a quality that does not represent that of the main flow. Care will be taken to sample at a point on the stream with complete vertical and lateral mixing. Samples will not be taken immediately below a waste source or tributary, unless there is a specific reason to do so.

Sampling in shallow lakes with good vertical mixing (as indicated by in situ measurements) will be accomplished with surface grab samples. Care will be taken that oil or gasoline leakage from the boat motor, if used, does not affect the water being sampled.

In rivers, streams, and very shallow lakes, fractions will be taken as a grab sample. The sample container will be held just beneath the surface of the water and allowed to fill.

Prior to the sample collection, each sample bottle will be rinsed with the stream water immediately downstream from the sampling point.

3.2.4 AIR

To avoid contamination when air sampling, air will be passed through the collection device before it is passed through the pump. All observations during the air sampling effort will be recorded in the field notebook, including the time of sampling initiation and

completion. Sampling rates will be measured in the complete sampling train, with the measurement process not altering the flow through the sampling train. Neither sampling time nor rate will exceed the time or rate determined during method certification.

3.2.5 SOIL

Prior to sampling, surface vegetation, rocks, leaves, and debris will be removed. Appropriate point sampling or compositing techniques, as defined in the task Technical Plan, will be used to ensure that the sample is representative of the area sampled and the type of information (e.g., depth of contamination) desired. Soil samples will be placed in an amber or foil-wrapped glass wide-mouth jar with Teflon®-lined lid. Sample containers will be labeled with a preprinted label, chilled to 4°C, and shipped to the laboratory for analysis. Sampling equipment will be thoroughly cleaned between sampling locations with water from an approved source. Sampling equipment will be rinsed and scrubbed with acetone and hexane after the water rinse and allowed to air dry. If a composite sample is required, a suitable compositing technique, such as that shown in Fig. 3.2-2, will be used. Each composite soil sample will consist of a homogenized composite of five subsamples taken within a 3- to 10-meter (m) radius at the selected sampling point. Each point sample taken from the surface to a specified depth should be quartered to approximately 0.5 kilogram (kg) and placed in the sample container.

Mixing of subsamples in the field to form a composite sample should be performed by placing the subsamples in a steel or aluminum tray lined with aluminum foil (dull side up). No plastic should be allowed to contact soil samples requiring organic analysis.

3.2.6 SEDIMENTS

All sediment samples will be collected with a hand piston sampler or other appropriate device. After sampling, depth of water at each sampling point will be measured and recorded. Sampling equipment will

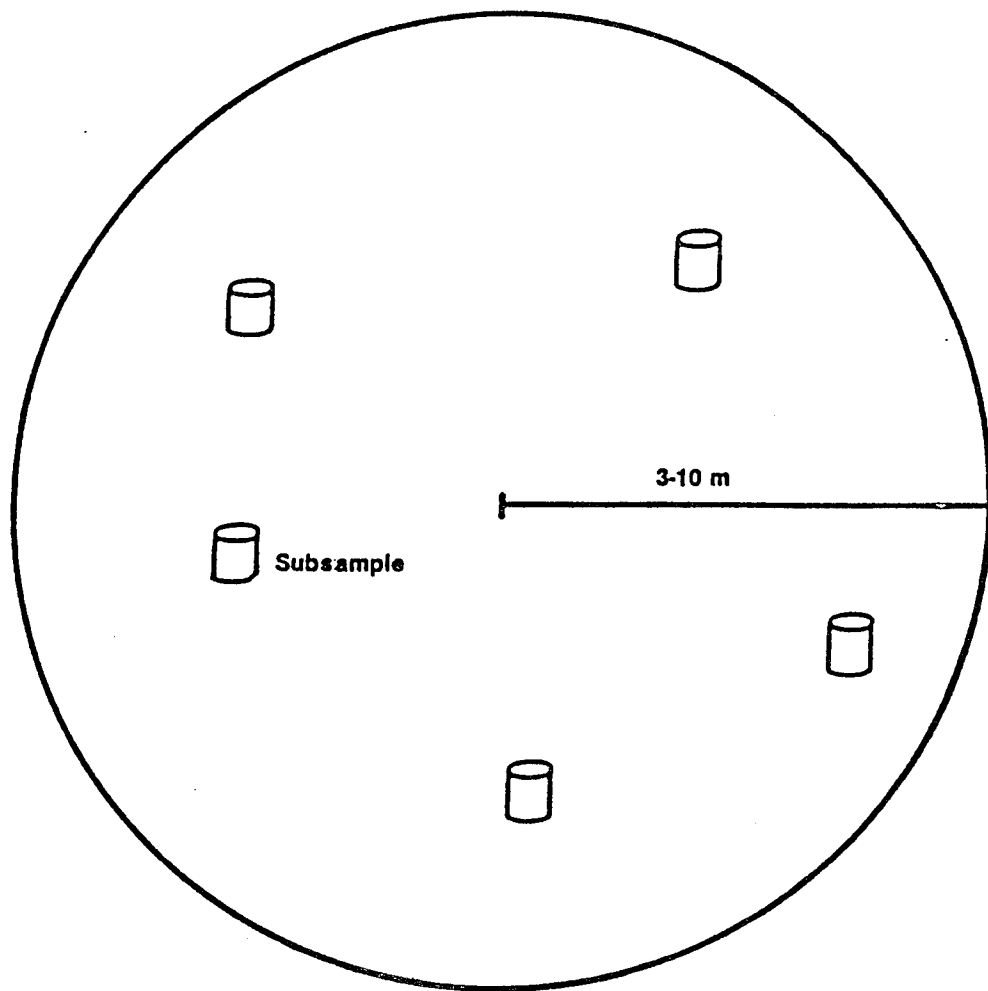

Figure 3.2-2
SURFACE SOIL COMPOSITE
SAMPLING METHOD

Prepared for:
U.S. Army Toxic and Hazardous
Materials Agency
Aberdeen Proving Ground, Maryland

be thoroughly cleaned with water from an approved source and solvent rinsed with acetone and hexane and allowed to air dry.

Sediment samples will be placed in amber glass or foil-wrapped containers with Teflon[®]-lined lids, shipped under ice, and stored at 4°C.

Observations recorded in the field notebook at time of soil sampling will consist of:

1. Site identification;
2. Description of location, including distance from surveyor's stake to sample point;
3. Date;
4. Time (24-hour system);
5. Description of vegetation;
6. Characteristics of soil;
7. Sample number;
8. Fractions and preservations;
9. Other observations; and
10. Signature of sampler.

3.3 SAMPLE PRESERVATION

The Field Team Leader is responsible for proper sampling, labeling of samples, preservation, and shipment of samples to the laboratory in a proper manner to meet required holding times. Table 3.3-1 identifies the proper container, preservation, and holding times that will be used for USATHAMA projects. Amber-glass bottles will be used for organic species that are susceptible to photodegradation. Plastic containers will be constructed from linear polyethylene. The holding times in Table 3.3-1 will apply to both water and soil/sediment samples.

Table 3.3-2 identifies the proper preparation of sampling containers to ensure that all samples properly represent constituents within the environmental matrix sampled. Responsibility for properly prepared

Table 3.3-1. Containers, Preservation, and Holding Times

Measurement	Container	Preservative	Maximum Holding Time
Acidity	P	Cool, 4°C	14 days
Alkalinity	P	Cool, 4°C	14 days
Ammonia	P	Cool, 4°C H ₂ SO ₄ to pH<2	28 days
<hr/>			
Biochemical oxygen demand	P	Cool, 4°C	48 hours
Biochemical oxygen demand Carbonaceous	P	Cool, 4°C	48 hours
Bromide	P	None required	28 days
Chemical oxygen demand	P	Cool, 4°C H ₂ SO ₄ to pH<2	28 days
Chloride	P	None required	28 days
Chlorine, total residual	P	Determine on site	2 hours
Color	P	Cool, 4°C	48 hours
Cyanide, total and amenable to chlorination	P	Cool, 4°C NaOH to pH>12 0.008% Na ₂ S ₂ O ₃ ^f	14 days
Dissolved oxygen			
Probe	G bottle & top	Determine on site	1 hour
Winkler	G bottle & top	Fix on site	8 hours
Fluoride	P	None required	28 days
Hardness	P	HNO ₃ to pH<2	6 months
Hydrogen ion (pH)	P	Determine on site	2 hours
Kjeldahl and organic nitrogen	P	Cool, 4°C H ₂ SO ₄ to pH<2	28 days
<hr/>			
<u>Metals^d</u>			
Chromium VI	P	Cool, 4°C	48 hours
Mercury	P	HNO ₃ to pH<2	28 days
Metals except above	P	HNO ₃ to pH<2	6 months
<hr/>			
Nitrate	P	Cool, 4°C	48 hours
Nitrate-nitrite	P	Cool, 4°C H ₂ SO ₄ to pH<2	28 days
Nitrite	P	Cool, 4°C	48 hours
Oil and Grease	G	Cool, 4°C H ₂ SO ₄ to pH<2	28 days
Organic Carbon	*G	Cool, 4°C H ₂ SO ₄ to pH<2	28 days

Table 3.3-1. Containers, Preservation, and Holding Times (Continued, Page 2 of 3)

Measurement	Container	Preservative	Maximum Holding Time
Organic Compounds ^e Extractables (including phthalates, nitrosamines organochlorine pesticides, PCB's, nitroaromatics, isophorone, polynuclear aromatic hydrocarbons, haloethers, chlorinated hydrocarbons and TCDD)	*G, teflon-lined cap	Cool, 4°C 0.008% Na ₂ S ₂ O ₃ ^f	7 days (until extraction) 30 days (after extraction)
Extractables (phenols)	*G, teflon-lined cap	Cool, 4°C 0.008% Na ₂ S ₂ O ₃ ^f	7 days (until extraction) 30 days (after extraction)
Purgeables (halocarbons, aromatics, Acrolein, and Acrylonitrile)	*G, teflon-lined septum	Cool, 4°C 0.008% Na ₂ S ₂ O ₃ ^f	14 days
Orthophosphate	P	Filter on site Cool, 4°C	48 hours
Pesticides	*G, teflon-lined cap	Cool, 4°C 0.008% Na ₂ S ₂ O ₃ ^f	7 days (until extraction) 30 days (after extraction)
Phenols	*G	Cool, 4°C H ₂ SO ₄ to pH<2	28 days
Phosphorus (elemental)	G	Cool, 4°C	48 hours
Phosphorus, total	P,G	Cool, 4°C H ₂ SO ₄ to pH<2	28 hours
Residue, total	P	Cool, 4°C	14 days
Residue, filterable	P	Cool, 4°C	14 days
Residue, nonfilterable	P	Cool, 4°C	7 days
Residue, settleable	P	Cool, 4°C	7 days
Residue, volatile	P	Cool, 4°C	7 days
Silica	P	Cool, 4°C	28 days
Specific conductance	P	Cool, 4°C	28 days
Sulfate	P	Cool, 4°C	28 days
Sulfide	P	Cool, 4°C Zinc Acetate	28 days

Table 3.3-1. Containers, Preservation, and Holding Times (Continued, Page 3 of 3)

Measurement	Container	Preservative	Maximum Holding Time
Sulfite	P	Cool, 4°C	48 hours
Surfactants	P	Cool, 4°C	48 hours
Temperature	P	Determine on site	Immediately
Turbidity	P	Cool, 4°C	48 hours

a - Polyethylene (P) or Glass (G).

b - Sample preservation should be performed immediately upon sample collection. For composite samples each aliquot should be preserved at the time of collection. When use of an automatic sampler makes it impossible to preserve each aliquot, then samples may be preserved by maintaining at 4°C until compositing and sample splitting is completed.

c - Samples should be analyzed as soon as possible after collection. The times listed are the maximum times that samples may be held before analysis and still considered valid. Samples may be held for longer periods only if the laboratory has data on file to show that the specific types of samples under study are stable for the longer time. Some samples may not be stable for the maximum time period given in the table. A laboratory is obligated to hold the sample for a shorter time if knowledge exists to show this is necessary to maintain sample integrity.

d - Samples should be filtered immediately on site before adding preservative for dissolved metals.

e - Guidance applies to samples to be analyzed, by GC, LC, or GC/MS for specific organic compounds.

f - This should only be used in the presence of residual chlorine.

(Compounds not found on Table 3.3-1 should be preserved at 4°C: storage: 1 week).

*Amber-glass bottle.

H₂SO₄ = Sulfuric acid.

NaOH = Sodium hydroxide.

Na₂S₂O₃ = Sodium thiosulfate.

HNO₃ = Nitric acid.

PCB = Polychlorinated biphenyls.

TCDD = Tetrachlorodibenzo-p-dioxin.

GC = Gas chromatography.

LC = Liquid chromatography.

GC/MS = Gas chromatography/mass spectrometry.

Source: EPA, 1979.

Table 3.3-2. Sample Container Cleaning Procedures

Analysis/ Parameter	Container Type	Matrix	Cleaning Procedure*
GC/MS Analyses Organic Compounds	Amber-Glass Bottle with Teflon®-Lined Cap	Water	1
	Glass Mason Jar-- Foil-Wrapped with Teflon®-Lined Cap	Soil/Sediment	1
Volatile Organics	Amber Septum Vial with Teflon®-Lined Septum	Water	2
GC/HPLC Analyses Organic Compounds	Amber Glass Bottle with Teflon®-Lined Cap	Water	1
	Glass Mason Jar-- Foil-Wrapped with Teflon®-Lined Cap	Soil/Sediment	1
Total Phenols	Amber-Glass Mason Jar with Teflon®- Lined Cap	Water	1
Oil and Grease	Amber-Glass Mason Jar with Teflon®- Lined Cap	Water	5
		Soil/Sediment	
Organic Carbon	Amber-Glass Mason Jar with Teflon®- Lined Cap	Soil/Sediment	1
Metals	Linear Polyethylene Cubitainer	Water	3
		Glass Mason Jar with Teflon®-Lined Cap	Soil/Sediment

Table 3.3-2. Sample Container Cleaning Procedures
(Continued, Page 2 of 2)

Analysis/ Parameter	Container Type	Matrix	Cleaning Procedure*
Anions:			
Cyanide, Nitrates, Sulfate, Phosphate, Fluoride, Chloride, Other Inorganics	Linear Polyethylene Cubitainer	Water	4
	Glass Mason Jar with Teflon®-Lined Cap	Soil/Sediment	1

- * 1--Thoroughly wash container with hot detergent and water; triple rinse with tap water; triple rinse with D.I. water; rinse with (nanograde) acetone; rinse with (nanograde) hexane; air-dry.
- 2--Thoroughly wash container with hot detergent and water; triple rinse with tap water; triple rinse with D.I. water; rinse with (nanograde) methanol; air-dry; bake at 100°C for several hours; soak septa for several hours in methanol; bake at 100°C for 10 to 15 minutes.
- 3--Rinse with 2 to 3 ml of ultrex nitric acid and drain thoroughly.
- 4--No cleaning procedure required; use new cubitainer.
- 5--Thoroughly wash container with hot detergent and water; triple rinse with tap water; triple rinse with D.I. water; rinse with nanograde freon; air dry.

Abbreviations

GC/HPLC = Gas chromatography/high-pressure liquid chromatography.
D.I. = Deionized.

Source: ESE, 1983.

sampling containers and preservation reagents rests with the Chemical Analysis Supervisor, based on the notification of the sampling schedule by the Field Team Leader and/or ESE Site Manager.

3.4 SAMPLE PREPARATION

The following paragraphs describe the preparation of water, soil, sediment, and standard samples for analysis. The Project QA Supervisor will monitor the sample preparation procedure to assure compliance with USATHAMA requirements.

3.4.1 SOIL SAMPLES

Percent moisture for soils and sediments will be determined prior to analysis by American Society for Testing and Materials (ASTM) Method D2216-71 (ASTM, 1981) on sieved and air-dried soils and wet sediments.

Soils will be dried and sieved before analysis. Samples will be placed in 13-inch (in) by 15-in aluminum trays, which are lined with aluminum foil (dull side up) and labeled with the sample number and air dried at room temperature. While drying, soil samples will be crushed gently with a mortar or the bottom of a small beaker. After soils are dried and thoroughly crushed, aliquots undergoing metals analyses will be sifted through a US Series 600 polyethylene sieve, and those undergoing organic analyses will be sifted through a US Series 600 brass sieve to remove rocks and vegetative material. Before every sample is sifted, the sieve will be thoroughly scrubbed with soap and water and rinsed with D.I. water, acetone, and hexane. Brass sieves are used for organics analysis to avoid phthalate contamination which occurs with polyethylene sieves, and, conversely, the plastic sieves are used for metals analysis to avoid trace metal contamination. Because the soils may be heavily contaminated with hazardous chemicals, appropriate safety precautions (as established in the Project Safety Plan), which may include the use of gloves, respirators, or a dust mask, will be taken during sieving. The unused and unsifted portion of the soil sample will be returned to its original container. The sifted sample will be placed in a clean, labeled glass jar with a Teflon®-lined lid.

3.4.2 SEDIMENT SAMPLES

Because of the long drying times involved in processing and sieving very wet sediments, sediments will be analyzed in their "wet" condition. The sediment sample will be made as homogeneous as possible by vigorous mixing with a spatula before a subsample is taken.

3.4.3 STANDARD SAMPLES

Preparation of standard soil and water for methods development and analytical systems control is described in Sec. 3.8.2. Standard samples for soil analysis consist of samples of an approved uncontaminated soil obtained from the installation or survey area of interest.

3.5 SUBSAMPLING

Subsampling the field soil sample to size will be performed by the analyst upon arrival of the sample at the ESE laboratory. All subsampling must be accomplished with the aid of the riffle or by proper quartering techniques, according to ASTM D346.

3.6 CONTROL SAMPLES

Control samples will be introduced into the train of actual samples as a monitor on the performance of the analytical system. Control samples will consist of a spiked standard or natural matrix samples and blanks. Results from spiked standard or natural matrix samples will be used to construct control charts to monitor variations in the precision and accuracy of routine analyses. The specific type and number of control samples and the construction of control charts are described in Sec. 4.2.

3.7 REFERENCE MATERIALS

All materials used to prepare calibration standards and spiking standards must be SARMS supplied by USATHAMA. SARMS or interim SARMS are materials that have undergone extensive purity and stability checks. Interim reference materials may be used when analyses must be run before a SARM is available. However, the following precautions must be taken:

1. The reference material will be stored at 0°C and a portion retained for a comparison with the approved SARMS when available;

2. The following data will be recorded as a minimum description of the material:
 - a. Infrared spectrum;
 - b. Melting point, decomposition point, or boiling point;
 - c. Nuclear Magnetic Resonance (NMR) spectrum;
 - d. Elemental analysis; and
 - e. GC or LC (by difference) analysis.

In cases where SARMS are difficult to obtain or only small amounts are available, interim SARMS or standards may be used for all calibration and spiking work, provided the purity and response of such materials can be compared to the purity of the SARMS. All reference compounds used in the USATHAMA projects will be stored at 0°C and protected from light. The QA Supervisor will request SARMS as required. The QA Supervisor maintains a record of receipt of SARMS and monitors their use. A written record of use of SARMS material which identifies the analyst and date of use is maintained.

3.8 ANALYTICAL METHODS AND CERTIFICATION

3.8.1 RATIONALE

Two different types of analyses recognized by the USATHAMA QA program (semiquantitative and quantitative analysis) may be conducted during tasks assigned under these contracts. Each type of analysis requires a different level of documentation, including precision and accuracy data and a different set of daily or batch-related QC criteria. The following sections outline the testing procedures which will be used to define the detection limit, precision, and accuracy of each analytical method.

Method certification in standard media will certify the laboratory to run semiquantitative or quantitative analyses for a given analyte. Documentation of the analytical testing certification will be submitted

to USATHAMA for approval before use of the analytical method for analysis.

3.8.2 METHOD CERTIFICATION

The following paragraphs describe the procedures to be used to certify analytical methods. All methods certification and documentation data will be developed in standard matrices.

The standard matrix for documentation of inorganic analyses (e.g., sulfate, nitrate, or metals) in water will be deionized water conforming to ASTM Type II grade water. The standard matrix for documentation of organic analysis will be deionized, organic-free (ASTM Type IV) water containing 100 milligrams per liter (mg/l) each of sulfate and chloride prepared as follows:

1. Add 1.48 grams (g) of dried reagent grade anhydrous sodium sulfate to a 1-liter (l) volumetric flask and dilute to volume.
2. Add 1.65 g of dried reagent grade sodium chloride to a 1-l volumetric flask and dilute to volume.
3. Transfer 100 ml of each (1 and 2) to a 1-l flask and dilute to volume.

The resulting solution is 100 mg/l each of chloride and sulfate ions. These two types of water will be used as blanks or will be spiked with the compound(s) of interest prior to processing through the complete analytical protocol.

The data for documentation of both inorganic and organic analyses in soils and aquatic sediments will be developed using an uncontaminated "standard" soil matrix from the installation. An aliquot of sieved (see Sec. 3.4.2) "standard" soil will be carried through each set of documentation samples to act as a blank. Added concentrations of the subject analyte(s) will be dissolved in a volume of solvent just sufficient to wet the soil. This solution is poured over the subsample

of soil and allowed to stand for 1 hour prior to beginning analysis, and the solvent is allowed to evaporate.

The "standard" soil will consist of a homogeneous sample of sufficient size to provide a single continuous source for all method documentation and subsequent analytical system control. The "standard" soil will be selected to conform with the type of soil to be encountered. However, any natural soil which contains no, or a very low level of, analytes to be detected may be used with the approval of the ESE Site Manager, QA Supervisor, USATHAMA Project Officer, and Central Laboratory QA Coordinator.

If, and only if, a column is to be used for the extraction, the analyte may be dissolved in the minimum quantity of the solvent consistent with volumetric transfer. The solution is placed on the column and allowed to soak in before additional extracting solvent is introduced.

Certain compounds or elements (e.g., nitrate or iron) will be present as a natural component of the soil. This background will be accounted for where it exists, and the detection limit for the particular method will be considered as the statistically resolvable quantity above the background concentration.

Semiquantitative Analyses

Semiquantitative analytical methods are used in USATHAMA programs to screen samples for the presence of unknown, as well as known, contaminants.

The detection limit of the total method will be estimated by spiking standard matrices of interest (water, soil, etc.) with the specific analytes or surrogate analytes at 0 (blank), 0.5X, X, 2X, 5X, and 10X, where X is the desired or required detection limit. The analyte should be dissolved in a water-miscible solvent to prepare the spiking solution. The spiked levels should be as close as possible to those

listed, but a reasonable attempt at producing these levels will be considered acceptable. The spiked samples will be analyzed through the entire analytical method. After analysis, the detection limit will be calculated using the USATHAMA detection limit program. The detection limit determined by this process will be reported as the detection limit of the semiquantitative method.

In summary, certification of a semiquantitative method requires the following:

1. One spiked standard matrix sample at each of five concentration levels, plus a blank analyzed in a single day.
2. The detection limit calculated using the USATHAMA detection limit program.
3. The precision of semiquantitative analyses will be reported as "999." on data management entries.
4. The accuracy will be the slope of the best-fit linear regression line of found versus target concentration.
5. The best-fit linear regression line must have a minimum correlation coefficient of 0.996 for the calculation of the detection limit and accuracy. Exceptions to this criterion must be approved by the USATHAMA Analytical Branch.
6. Documentation of the procedures in USATHAMA format.

Semiquantitative certification for the GC/MS analysis will be performed using a mixture of actual analytes and surrogate standards.

Quantitative Analyses

Requirements for certification of a quantitative method are as follows:

1. One spiked standard sample at each of five concentration levels, plus a blank analyzed each day for 4 separate days.
2. The detection limit will be calculated using the USATHAMA detection limit program.

3. The precision of the quantitative analyses will be the standard error of the best-fit linear regression line of found-versus-target concentration values for the data generated during the certification testing.
4. The accuracy of the quantitative analyses will be the best-fit linear regression line of found-versus-target concentration.
5. Documentation of the procedures in USATHAMA format.

3.9 ANALYST CERTIFICATION

A list of qualified personnel for each sampling and analytical task will be provided by the appropriate Group Leaders to the Project QA Supervisor. The QA Supervisor will keep a logbook arranged by type of analysis (e.g., Autoanalyzer, atomic absorption, GC, GC/MS, etc.). Analysts' names will be entered under the qualified headings with the Group Leader's initials and date certified (Fig. 3.9-1). At regular intervals, each Group Leader will review the capabilities of each analyst and recommend whether certification should be continued. A similar log will be maintained for the field sampling team members.

During the conduct of this project, the QA Supervisor will inspect the laboratory periodically to determine if analyses are being performed only by certified analysts. Data reports require the name of the analyst on the report sheet. All sample lots will be checked to verify that certified analysts performed the analyses. Reruns of samples will be required if certified analysts did not perform the analysis.

Analysts will demonstrate their proficiency in conducting a particular chemical analysis by showing evidence of acceptable performance on past routine QC samples analyzed with each batch of samples.

In addition, for any analytical method, analysts or an analytical team consisting of specific individuals will be considered to be certified to run a particular analysis, if they have been involved in developing the precision and accuracy data needed for method documentation. The precision and accuracy data generated during method documentation must

ANALYSIS TYPE _____

AUDITOR _____

Analyst	Analysis	Certified		Date	Comment
		Yes	No		

Figure 3.3-3
TYPICAL CERTIFICATION
AUDIT PAGE

Prepared for:
U.S. Army Toxic and Hazardous
Materials Agency
Aberdeen Proving Ground, Maryland

be acceptable to the Analytical Team Leader and the QA Supervisor. New analysts performing an established analytical procedure will be considered to be conditionally certified until the first set of QA/QC data are generated. These QC data are required for every lot of samples analyzed. If these QC data meet the criteria of precision and accuracy established during method documentation, the analyst or analytical team will be considered to be certified to run that particular analysis. QC data which do not meet established QC requirements will be rejected, and corrective action which may include reanalysis of the lot of samples and further training of the analytical team, will be taken.

4.0 ANALYSIS OF SAMPLES

The following describes the QC procedures and requirements for sample analyses conducted during this project. These QC requirements are in addition to any specific calibration requirements presented in Sec. 5.0. All samples will be analyzed within the certified range of the analytical method. For water samples, dilution of the original sample matrix with distilled/deionized water should be performed if the concentration of analyte is greater than the certified range of the method. For soil and sediment samples, a smaller aliquot of sample should be analyzed if the concentration of analyte is greater than the certified range. The minimum sample size will be 1.0 ml for water samples [except volatile organics analysis (VOA)] and 1.0 g for soil and sediment samples.

4.1 LABORATORY INSTRUMENT QC CONTROLS

Daily QC of the analytical systems ensures that accurate and reproducible results are produced. A sophisticated data check program described in the Data Management Plan will automatically check instrumental calibration data for compliance with QC requirements. Out-of-control data will be automatically flagged and brought to the analyst's attention. Table 4.1-1 describes the instrumental checks to be implemented by ESE for USATHAMA projects.

Initial calibration should be performed under the following conditions: (1) when an analysis is first set-up or prior to the first set of samples, (2) when the instrument has been idle for long periods of time, (3) when the instrument detector has been subject to major maintenance, or (4) when the instrument fails the daily calibration QC checks.

Deviations from the USATHAMA instrumental QC requirements will occur for certain analyses. The requirement for recalibration of the instrumental

Table 4.1-1. Summary of Instrumental Systems Control Requirements

Requirement	Analytical Control Limits
<ul style="list-style-type: none"> Initial Calibration (using actual analytes or surrogates) (GC/MS uses surrogates and actual analytes) 	<ul style="list-style-type: none"> Calibration curve--concentration series 0 (blank), 0.5X, X, 2X, 5X, and 10X, where X is the concentration of analyte in the instrumental standard corresponding to an analyte concentration in the sample at the desired detection limit
<ul style="list-style-type: none"> Daily Calibration (except GC/MS, ICAP) 	<ul style="list-style-type: none"> Calibration curve--concentration series 0 (blank), X, 5X, and 10X minimum All samples analyzed must be bracketed by standards above and below and be within the established certified range of the method Calibration standard is repeated at end of day or analytical run, and response of the standard must agree with previous response within <u>+15%</u> Correlation coefficient of standard curve <u>>0.995</u>
<ul style="list-style-type: none"> Daily GC/MS Calibration 	<ul style="list-style-type: none"> One calibration standard is run and calculated response factor for surrogate analytes must agree with initial calibration response factors within <u>+25%</u> or new calibration curve run All samples analyzed must be within the linear range of the instrument and the certified range of the method
<ul style="list-style-type: none"> Daily ICAP Calibration 	<ul style="list-style-type: none"> Instrument calibration with DFTPP or BFB One calibration standard is run at the beginning and the end of the analytical run. Response at end of run must be within <u>+5%</u> of the beginning of run standard. All samples analyzed must be within the linear range of the instrument and the certified range of the method

ICAP = Inductively coupled argon plasma.
DFTPP = Decafluorotriphenylphosphine.
BFB = Bromofluorobenzene.

system at the end of each day's run is not practical or necessary for certain analyses using standard EPA procedures because of the excessive time required for calibration. For most analyses (cyanide, phenols, GC, HPLC, nutrients, etc.), only one calibration standard will be repeated at the end of the day. For metals determination by ICAP, the daily calibration (after the initial multi-point calibration curve has been established) will be a one-point standard at the beginning and at the end of the analytical run. This procedure is consistent with EPA recommendations. All samples analyzed will be bracketed by calibration standards.

4.2 CONTROL SAMPLES

Control samples are spiked samples of standard water, natural water, or a "clean" background soil from the particular installation being surveyed, which are run with each lot of samples. As part of the automated QC checks, the ESE data management system checks the results of control spikes run with each Army lot and flags all data that are out of control. Table 4.2-2 summarizes the control samples and control charts required for the USATHAMA projects.

In applying the QC requirements presented in Table 4.2-2 to quantitative analyses and parameters, at least three control samples will be run on each day of instrumental analysis. In applying the QC requirements presented in Table 4.2-2 to some analyses and parameters, modifications to these requirements may be necessary. For certain GC, high-pressure liquid chromatography (HPLC), and GC/MS analyses, the daily throughput of samples is severely limited by the instrument analysis runtime. In these cases, ESE will define a group of samples which are extracted in 1 day as a lot and apply the control spike requirements to this extraction lot. At least one control spike extract will be analyzed on each day of instrument analysis. USATHAMA approval of this deviation will be required prior to sample analysis, and this deviation will be specified in the Site Project Plan of Study.

Since certification for semiquantitative analyses only requires that one target-versus-found curve be established, the designation of control limits for accuracy based upon the standard deviation of the slopes of a number of target-versus-found curves is not possible. In this case, ESE will use historical data from previous analyses (if any) or will set up temporary control limits on the slope of the control sample curves of +20 percent. As the number of control samples analyzed increases, criteria based on +3 (standard deviation of slope) will be established.

The Laboratory QA Coordinator is responsible for introducing the control samples into each analytical lot before analysis. Subsequent to analysis, the Project QA Supervisor reviews and approves all control sample data by Army lots before the results are transmitted to USATHAMA as Level 1 data. Precision, accuracy, and the detection limit for each analytical lot which passes QC criteria are automatically entered into the appropriate chemical analysis file for weekly transmission to USATHAMA. The QC results for the QC control samples also are included in the format required by the Installation Restoration (IR) Data Management User's Guide (USATHAMA, 1981).

Failure to pass the instrumental calibration or control sample QC criteria represents an out-of-control situation and calls for corrective action as required by the USATHAMA QA Plan, which may require rerunning and/or resampling and rerunning the entire lot samples. Written notification of QC failure is provided to the ESE Site Manager and the Chemistry Supervisor.

5.0 INSTRUMENT CALIBRATION AND MAINTENANCE

A calibration procedure establishes the relationship between an accurately known calibration standard and the measurement of that standard by an instrument or analytical procedure. Calibration is not to be confused with standardization. Standards are run each time an instrument or procedure is used, while instrument calibration is performed only at specified intervals.

Operating procedures must be available for all equipment and analytical instrumentation. Such procedures are generally provided by the manufacturer.

Written procedures for the operation and calibration of instrumentation are provided to the analyst in the laboratory to help minimize possible measurement inconsistencies due to differing techniques, conditions, and choice of standards. The procedures include the following information:

1. The specific instrument (or group of instruments) and analysis for which the procedure is applicable;
2. An explanation of theoretical considerations pertinent to the understanding of both the calibration procedure and the analysis;
3. Fundamental calibration specifications;
4. A list of requisite standards and equipment for the procedure;
5. Complete presentation of the procedure in a clear, step-by-step manner; and
6. Specific instructions for obtaining and recording calibration information.

An up-to-date report for each calibration standard used in the calibration system should be provided. If calibration services are performed

by a commercial laboratory on a contract basis, copies of reports issued by them should be maintained on file.

All contractor calibration reports are kept in a suitable file by the QA Supervisor and contain the following information:

1. Report number;
2. Identification or serial number of the calibration standard to which the report pertains;
3. Conditions under which the calibration was performed (temperature, relative humidity, etc.);
4. Accuracy of calibration standards (expressed in percentage or other suitable terms);
5. Deviation or corrections; and
6. Corrections that must be applied if standard conditions of temperature, etc., are not met or differ from those at place of calibration.

Contracts for calibration services should require the contractor to supply records on traceability of their calibration standards.

All equipment to be calibrated should have affixed to it, in plain sight, a tag bearing the following information:

Description: _____
Identification No.: _____
Last Calibrated: _____
Calibrated By: _____
Calibration Expires: _____

NOTE: Use of this instrument beyond the calibration expiration date is prohibited.

When the equipment size or its intended use limits the application of labels, an identifying code should be applied.

Equipment past due for calibration should be removed from service either physically or, if this is impractical, impounded by tagging or other means.

5.1 FIELD INSTRUMENT CALIBRATION

Instruments used to perform field measurements (e.g., pH, temperature, conductivity, water level) will be calibrated in accordance with procedures outlined in the appropriate operating manual. All equipment will be calibrated daily or after every 20 observations. Calibration checks will be performed after measurements are made at each sampling site. All calibration data and calibration checks will be entered into the field notebook. Failure of an instrument to maintain accurate calibration will be reported to the Field Team Leader, who must take immediate corrective action to ensure that accurate field data accompany any samples. The faulty instrument is tagged and cannot be used until repaired and until recalibration is verified by the Project QA Supervisor.

In the event that field measurements must be made using instruments having questionable accuracy or calibration, the Field Team Leader must immediately identify the problem to the QA Supervisor. If recommended corrective action involves including suspected measurements in the sampling record, this must be approved in writing by the ESE Site Manager, USATHAMA Project Officer, and Central Laboratory QA Coordinator. Generally, if proper field measurements cannot be performed, alternative means will be employed to verify the field data, which will be discarded, or the system will be resampled when accurate field measurements can be performed. These corrective actions will be agreed upon by the QA Supervisor, ESE Site Manager, USATHAMA Project Officer, and USATHAMA Central Laboratory QA Coordinator.

5.2 ANALYTICAL NOTEBOOKS AND INSTRUMENT LOGBOOKS

The ultimate repository for information concerning analyses performed in the laboratory is the analyst's personal laboratory notebook and the instrument logbooks.

Each analyst is required to have a personal notebook designated by a unique number. Responsibility for maintaining complete laboratory notes lies with each analyst. The ESE QA Supervisor may audit laboratory notebooks without notice. The list of assigned notebooks is maintained by the Department Secretary and contains the following information:

1. Notebook number,
2. Assignee,
3. Responsible Group Leader, and
4. Disposition or location and date.

Laboratory notebooks will not be taken from ESE without written permission of the Chemical Analysis Supervisor and the ESE Site Manager. Every entry into the notebook should be dated and signed. Entries in the personal notebook will vary depending on the role of the individual in the laboratory and the type of work being performed. At a minimum, the personal notebook should contain:

1. A reference to or a description of the procedures used for sample work-up or analysis,
2. A summary of the samples extracted or analyzed,
3. Weighings and calculations of standard concentrations, and
4. Information on spiking procedures and observations and comments on the procedures or samples.

An instrument logbook will be maintained for certain analyses. Each time an instrument is used for sample analysis, the following information is entered:

1. Date of analysis;
2. Project name and number;
3. Number of samples analyzed, type of sample;
4. Time spent on analysis (start to finish);

5. Preventive maintenance performed, if any;
6. Time spent on preventive maintenance;
7. Instrument calibration performed, if any; and
8. Name of analyst.

Additional notes are made in the instrument logs when required. These notes are particularly important when abnormal instrument or analytical performance is observed. It is the analyst's responsibility to ensure that instrument logs are properly filled out and kept up to date. The QA Supervisor monitors and audits the status of instrument logbooks.

5.3 SPECIFIC ANALYTICAL SYSTEMS CONTROL

5.3.1 METALS SYSTEM CONTROL

The following are the routine QC procedures required for flame and graphite furnace atomic absorption analysis (AAS):

1. Instrument calibration is checked using standard solutions. Instrument response is plotted (using a hand calculator) against concentration. The slope is compared to historical slope data to verify that the performance of the instrument is satisfactory. The control charts are kept in the instrument logbook, which also contains a record of routine maintenance and documentation relating to any downtime due to instrument malfunctions. If readings are excessively low, the analyst will check gas flows, burner or cell alignment, wave length, slit width, photomultiplier voltage, and lamp intensity for problems.
2. Blanks, sample duplicates, and spiked samples are analyzed with each batch of samples.
3. Strip chart recorder tracings for standard solutions, samples, spikes, and duplicates are all stamped for identification and filed in the instrument room.

Analyses run on the ICAP system will require specific instrument calibration and maintenance controls. Routine maintenance on the

Jerrill-Ash ICAP system by the manufacturer's representatives is performed on an annual basis. In addition, a quarterly service contract is maintained on the minicomputer.

Monthly, the analyst will dismantle, clean, and reassemble the torch and nebulizer to prevent serious sensitivity problems. Calibration with selected standards will be performed daily to ensure that the instrument performance has not deteriorated. The failure to achieve standardization could require cleaning, including changing the tubing of the sample delivery system. Spare parts are available for the system components most likely to experience failure.

5.3.2 NITRITE PLUS NITRATE, SULFATE, AND PHOSPHATE ANALYSES

The following are the routine QC procedures required for nitrate and sulfate analysis using Technicon Autoanalyzer and Hach Turbidimeter:

1. Standard calibration setting must be within specified limits for each standard range and each parameter;
2. Color and turbidity blanks must be run on all samples with visible color; and
3. A notebook containing strip charts, sample logs, instrument maintenance and standard conditions will be kept by parameter. All deviations from the standard conditions must be recorded and corrected, with all corrective action explained.

Additional maintenance of the Technicon Autoanalyzers will include daily inspection of pump tubes for deterioration and replacement. The temperature of the instrument room and reagent will be controlled to maintain equipment stability.

5.3.3 GC ANALYSIS

GC septa will be replaced on a weekly basis or more frequently as needed when symptoms of septum deterioration are noted. Frequent injections will require replacement on a daily basis. When the supply of gas in the cylinders falls below 100 psi, carrier and detector gases will be

changed to prevent contaminants from reaching the detector or columns. Molecular sieves and oxygen traps used in the gas lines will be replaced on a regular basis. GC detectors will be removed and cleaned at least every 6 months to remove accumulations, which can affect instrument performance.

Instrument calibration curves will be monitored and compared to historical performance criteria. Excessive noise, low response, and poor precision are indicators of a dirty detector and may cause more frequent detector cleaning. Spare columns, packing materials, instrument cables, and PC boards will be available in case of breakage or malfunction to minimize instrument downtime.

5.3.4 GC/MS ANALYSIS

Daily instrument control will be practiced to ensure that the instrument is calibrated and in proper working condition. The GC/MS will be tuned daily with perfluorotributylamine to calibrate the mass axis and to ensure proper relative abundances. The instrument performance will be monitored with a reference compound such as decafluorotriphenylphosphine and/or with a composite mixture of compounds representative of the samples being analyzed. An instrument tuning log will be maintained to identify any deterioration of instrument performance. The composite reference mixture will be particularly useful for monitoring the relative sensitivity of the mass spectrometry (MS) and the integrity of the chromatographic column. Failure to achieve calibration will require implementation of source cleaning procedures.

In addition, all routine analytical systems controls performed for GC will also be performed for the GC/MS equipment. The ionizing source will be periodically dismantled, thoroughly cleaned, and reassembled to prevent serious sensitivity problems.

6.0 AUDITING AND REPORTING OF DATA

The Project QA Supervisor is responsible for reviewing and approving all field and sampling analytical data before transmittal of data to USATHAMA. Further, all data transmitted to USATHAMA must be validated by the Project QA Supervisor or his representative according to procedures specified in "Sampling and Procedures and Tables for Inspection by Attributes, Military Standard" (MIL-STD-105D, April 29, 1963) before elevating the data to Level 2.

For the efficient flow of laboratory data to USATHAMA, it is critical that the QA and supervisory reviews of data be organized in a planned methodology which includes successful interface with the data management program. ESE has developed a USATHAMA project data review and transmittal procedure which requires that a formal review and sign-off sheet accompany chemical analysis results of each completed lot of samples. The data are routed to several individuals for approval. This form is presented in Fig. 6.1-1. ESE will use this review procedure for the proposed project.

6.1 SEMIQUANTITATIVE ANALYSES

Results will be reported in terms of concentrations in the original matrix and will be corrected for recoveries, moisture, systematic errors, etc., if these are known. Lack of indications of the presence of specific compounds to be reported should be reported as "less than" the detection limit. Estimates of concentrations of species which have not been subjected to the detection limit procedure, as in the GC/MS screening procedure, may be reported based on the response compared to the response of a reference compound or internal standard provided that: (1) the instrumental response of the species is not less than one-tenth of the response at the documented detection limit of the reference

ENVIRONMENTAL SCIENCE AND ENGINEERING, INC.

ARMY DATA REVIEW AND TRANSMITTAL FORM

ARMY LOT: _____

PROJECT NAME: _____

ESE BATCHES: _____

PROJECT NUMBER: _____

	Date	Initials	Comments
1. Group Leader (Army Batch Complete-All ESE Batches Grouped in Army Batch)			
2. Data System Coordinator (MARSQC, ESE Report)			
3. Group Leader Review and Approval			
4. Chemical Supervisor Review and Approval			
5. Data System Coordinator (Corrected ESE Report/ MARSQC USATHAMA Report)			
6. Chemical Supervisor Approval			
7. QA Supervisor (ESE Report, USATHAMA Report, MARSQC)			
8. Data System Coordinator Review and File			
9. Transmittal to Army (WTC)			

Note: Data may be released to the ESE Project Manager as preliminary data subject to revision after the review of the QA Supervisor in Step 7.

COMMENTS: _____

Figure 6.1-1
 ARMY DATA REVIEW FORM
 (Reduced)

Prepared for:
 U.S. Army Toxic and Hazardous
 Materials Agency
 Aberdeen Proving Ground, Maryland

compound; (2) the detection limit of the reference compound has been estimated; (3) the estimated concentration contains only one significant figure; (4) the estimated concentration is annotated as based on the reference compound; and (5) the estimated concentration is reported as the concentration in the original matrix assuming 100 percent recovery.

Results of the semiquantitative analyses will be entered into the Data Management System of USATHAMA, as outlined in the IR Data Management User's Guide (USATHAMA, 1981) with the following conditions:

1. Four characters (3 digits plus a decimal) to represent the slope of the least squares regression line of found-versus-target concentration values for QC standard additions data in spiked standard or natural samples obtained on the date of analysis will be entered in the "Accuracy" columns.
2. For semiquantitative analyses in which estimates are based on a reference compound, the 3 digits for accuracy will be "000."
3. The precision of semiquantitative analysis will be reported as "999." on data management entries.

6.2 QUANTITATIVE ANALYSES

Estimates of concentration levels in quality control and actual samples will be reported to USATHAMA according to the guidance as outlined in the program tasking and the Data Management Users Guide. Reported values will be corrected for recoveries and moisture over the total analytical method to offer the best estimate of the actual concentration in the original matrix. Values less than the average detection limit will be reported as "less than" the detection limit. Conversely, detection limits higher than the average detection limit (as in the case of a sample with high background levels) will be reported as "less than" the higher detection limit.

The accepted slope of the best-fit linear regression line of found-versus-target concentration values from QC standard additions data in

spiked standard or natural samples obtained on the date of analysis will be reported as the accuracy.

The standard error of the best-fit linear regression line of found-versus-target concentration values for QC standard additions data in spiked standard or natural samples obtained on the date of analysis will be reported as the precision of the measurements for that day.

The documented detection limit will be used to report data for the quantitative method. The documented detection limit is obtained by combining data obtained during the method documentation certification to generate detection limit using the USATHAMA detection limit program with 90-percent confidence limits.

BIBLIOGRAPHY

- American Society for Testing and Materials (ASTM). 1981. Laboratory Determination of Water (Moisture) Content for Soil/Rock/Soil-Aggregate Mixtures (D2216-71). In: Annual Book of ASTM Standards: Part 19, Natural Bedding Stones; Soil and Rock; Peats, Mosses, and Humus. Philadelphia, Pa.
- U.S. Army Toxic and Hazardous Materials Agency (USATHAMA). 1981. Installation Restoration (IR) Data Management User's Guide, Volume 1, General Procedures, Edgewood, Md.
- U.S. Environmental Protection Agency (EPA). 1979. Guidelines Establishing Test Procedures for the Analysis of Pollutants; Proposed Regulations; Correction. Federal Register 44(244):75050-75052.