

BUSINESS PROCESS RE-ENGINEERING APPLIED TO
THE AIR FORCE INSTITUTE OF TECHNOLOGY
OFFICE OF THE REGISTRAR, RECORDS MANAGEMENT

Thesis

Captain Connie C. Hutchinson
Captain Alison F. McCoy

AFIT/GIR/LAR/94D-5

This document has been approved
and its contents are
unclassified.

DEPARTMENT OF THE AIR FORCE
AIR UNIVERSITY
AIR FORCE INSTITUTE OF TECHNOLOGY

Wright-Patterson Air Force Base, Ohio

19941221 130

AFIT/GIR/LAR/94D-5

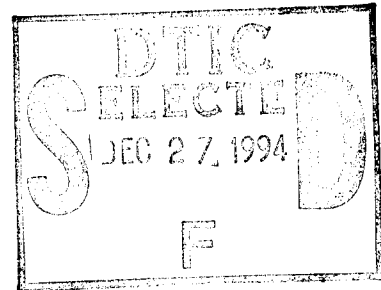

**BUSINESS PROCESS RE-ENGINEERING APPLIED TO
THE AIR FORCE INSTITUTE OF TECHNOLOGY
OFFICE OF THE REGISTRAR, RECORDS MANAGEMENT**

Thesis

Captain Connie C. Hutchinson
Captain Alison F. McCoy

AFIT/GIR/LAR/94D-5

Accession For	
DTIC UNCLASSIFIED	<input checked="" type="checkbox"/>
DTIC RESTRICTED	<input type="checkbox"/>
DTIC CONFIDENTIAL	<input type="checkbox"/>

A-1

Approved for public release; distribution unlimited

The views expressed in this thesis are those of the authors and do not reflect the official policy or position of the Department of Defense or the U. S. Government.

AFIT/GIR/LAR/94D-5

BUSINESS PROCESS RE-ENGINEERING APPLIED TO
THE AIR FORCE INSTITUTE OF TECHNOLOGY
OFFICE OF THE REGISTRAR, RECORDS MANAGEMENT

THESIS

Presented to the Faculty of the Graduate School of Logistics and Acquisition Management
of the Air Force Institute of Technology
Air University
in Partial Fulfillment of the
Requirements for the Degree of
Master of Science in Information Resource Management

Connie C. Hutchinson, B.A.
Captain, USAF

Alison F. McCoy, B.S.
Captain, USAF

December 1994

Approved for public release; distribution unlimited.

Acknowledgments

We would like to take this opportunity to recognize those individuals whom were major contributors and supporters of this research effort. First, our thesis advisors, Major Steve Teal and Captain Dave Morgan, were very supportive throughout the entire study and were always ready to lend additional assistance when needed. Captain Morgan's assistance was especially appreciated since he came to the team while he was still a graduate student at AFIT. We also appreciate the efforts of Major Gordon Wishon, USAF Retired, for his input prior to his retirement and relocation to Georgia. In addition, we could not have accomplished this research without the pledged support from the AFIT Registrar, Ms Maria Vasquez. All of the personnel within the Records Management section and Counseling Services were vital elements, and special appreciation is extended to Mr Randy Baker, Ms Donna Collins, and SrA Shelia Thompson for their insightful inputs. Last, but certainly not least, we wish to publicly thank our husbands and children, David and Casey Hutchinson and Mark McCoy for their understanding and support during the last 18 months. Without your caring, concern, and understanding we would not have been able to accomplish this formidable task. Thank you.

Connie C. Hutchinson
Alison F. McCoy

Table of Contents

	Page
Acknowledgements	ii
List of Figures	v
List of Tables	vi
Abstract	vii
I. Introduction	1
Overview/Background	1
Operational Definitions	3
Specific Problem	4
Scope of Research	4
Investigative Questions	5
Significance of Research	5
Preview	6
II. Literature Review	7
Introduction	7
Business Process Re-engineering and IDEF	7
Method of Treatment and Organization	9
Discussion of Literature	9
The Department of Defense	13
Conclusion	15
III. Methodology	17
Introduction	17
Methodology	17
Applications	18
Team Design	24
Data Collection Plan	24
Data Analysis Plan	24
Time Constraint	25
Summary	25
IV. Data Analysis	26
Introduction	26
Functional/Technical Expert Team	26
Objectives of the Records Management Process	27

	Page
Baseline As-Is Modeling	27
Activity Based Costing	29
Process Time Duration	29
Process Frequency	29
Pay Grades	30
Cost Centers	30
"To-Be" Modeling	33
Investigative Questions	42
Summary	43
V. Conclusions and Recommendations	44
Introduction	44
Conclusions: Lessons Learned	44
Exploratory Interviews	44
Functional/Technical Team	45
"As-Is" Baseline Modeling	46
"To-Be" Modeling	47
Recommendations	47
Summary	48
Appendix A: IDEF0 "AS-IS" Model with Costs	49
Appendix B: Flow Charts/Models for Duration	71
Appendix C: Glossary for "AS-IS" Model	81
Appendix D: IDEF0 "TO-BE" Model	95
Appendix E: Glossary for "TO-BE" Model	105
Appendix F: Exploratory Interviews	112
Bibliography	123
Vitas	125

List of Figures

Figure	Page
1. IDEF0 Format	21

List of Tables

Table	Page
1. BPR Methodology Summary	18
2. Initial Baseline "As-Is" Activities and Sub-Activities	28
3. Hourly Pay Rates	30
4. Costs Centers	31
5. Initial Baseline "As-Is" Activities and Sub-Activities	32
6. Session 1--Group Comments	35
7. Session 1--Expanded Group Comments: List B	36

Abstract

This study analyzed the processes performed by the Officer Academic Education Repository at the Air Force Institute of Technology at Wright-Patterson Air Force Base, Ohio. Business Process Re-engineering (BPR) methodology was used to define the existing processes. IDEF0 (Integrated Computer Aided Manufacturing Definition Language) and Activity Based Costing techniques were used to map the flow of activities and to determine the costs for handling one education record. The cost for processing one education record averaged approximately \$69.95. Under BPR, the functional expert team evaluates the existing processes to determine which processes are value-added and which are non-value added and generate "to-be", or improved process model. The original intentions of this study were to comply with traditional BPR methodologies to develop the "to-be" model, however this did not occur due to various factors. The thesis team developed the "to-be" model and received validation from one of the functional team members. Because of the difficulties encountered by the thesis team in developing the "to-be" model, the conclusions presented include a section on "lessons learned" to assist future BPR efforts.

BUSINESS PROCESS RE-ENGINEERING APPLIED TO
THE AIR FORCE INSTITUTE OF TECHNOLOGY
OFFICE OF THE REGISTRAR, RECORDS MANAGEMENT

I. Introduction

Overview/Background

The United States Government is facing a major task: create "a government that works better and costs less" (Gore, 1993:124). To meet this challenge, Department of Defense (DoD) functional managers are taking a critical look at organizational processes and making major renovations to the way they do business. The concept of Business Process Re-engineering (BPR) has been adopted by the DoD and incorporated in the guidelines found in *DoD 8020.1-M, Functional Process Improvement*. Air Force functional managers are tasked to follow the procedures outlined in this manual to re-engineer the processes in their organizations.

The application of BPR to DoD functions was initiated under the Bush administration by the Deputy Secretary of Defense Memorandum, *DoD Corporate Information Management (CIM)*. According to former Deputy Secretary of Defense, Mr. Atwood, a top priority for the DoD was ". . . to realize major improvements in internal DoD business processes" (Strassmann, 1992:12). The result was the development of CIM, whose mission is to assist DoD organizations in operating more like civilian businesses by focusing on optimizing cost and performance excellence (CIM, 1993:5). Since its introduction, BPR has earned a respected reputation as a crucial management tool. The former Director of Defense Information, Paul A.

Strassmann, recognized the value of using BPR in the DoD: ". . . we are committed to the idea that CIM is primarily a functional improvement process. . . . We have now put into place process improvement policies, manuals, and tools" (Strassmann, 1992:14). In 1991, the Defense Information Systems Agency (DISA) awarded a 200 million dollar contract to BPR consultants to initiate improvement programs for the DoD (Moore, 1993:4). As of October 1992, Mr. Strassmann reported that the DoD had completed almost 100 BPR programs, including tactical fire support, fleet maintenance, OSD staff activities, and health services activities (Strassmann, 1992:15). As part of the CIM initiative to implement BPR projects, a large-scale BPR effort involving the 20 degree-granting institutions--which includes AFIT-- generally described as the "DoD Universities" has emerged in response to a Congressional and General Accounting Office investigation of the service academies' costs and business practices. One of the primary areas targeted for study are the registrar/student records departments (Moore, 1993:8-9).

While investigating possible topics for thesis research, the AFIT Registrar suggested a study evaluating recent manpower cuts and optimizing the use of the remaining personnel. Additionally, they noted that the Records Management section is in the process of integrating electronic records through optical disk storage. This technology acquisition is a concern to this BPR effort because BPR experts agree that technology should be added only after business processes have been re-engineered (Corbin, 1993:28). According to Michael Hammer, an enthusiastic advocate of BPR, the application of technology serves as an "essential enabler," but warns that ". . . the misuse of technology can block re-engineering altogether and reinforce old ways of thinking and old behavior patterns" (Hammer, 1993:83). Also, according to Bureau of Labor Statistics, increased spending on information technology does not guarantee increased productivity (Corbin, 1992:46). Taking these cautions and the current business environment of this organization into consideration, the aim of this thesis is to document

processes as they currently exist, identify areas for process improvement, and propose re-engineering alternatives to optimize the existing manpower. In conjunction with these proposed re-engineering alternatives, the role of the optical disk storage system will be discussed.

Operational Definitions

Due to the widespread success of BPR in many business domains, the emergence of variations of this strategy have subsequently produced variations of the terms used to describe and define BPR. Because this research is DoD driven, the following definitions have been taken from *DoD 8020.1-M* and the *CIM Process Improvement Methodology for DoD Function Managers*.

1. Functional Process Improvement (FPI): The application of a structured methodology to define a function's "as-is" environment, its objectives and strategy for achieving those objectives, and a program of incremental improvements made through functional, technical, and economic analysis and decision making. Also known as Business Process Improvement (BPI) and Business Process Re-engineering (BPR).
2. Functional Area: A major, broad area of responsibility within an enterprise. Example: The Office of the Registrar (AFIT/RR) is a functional area within the Air Force Institute of Technology.
3. Functional/Technical Team: Composed of one or more technical experts drawn from each of the functional areas involved in the re-engineering project.
4. Activity: A major business element or operation within a functional area. Example: The maintenance of officer education records is an activity within the Officer Academic Education Repository (AFIT/RRA).
5. Process: A subset of the enterprise activity. Example: The creation of officer education records is a process within the Officer Academic Education Repository, a functional area of AFIT/RR.
6. Tasks/Steps: Individual actions and/or decision points within each process, which taken in aggregate comprise that process. Example: Retrieving a record

from the files, evaluating transcripts, and updating the computer database are some of the tasks within the creation of officer education records process.

7. "As-Is": The baseline processes.
8. "To-Be": The target processes.
9. Value added processes: Those which support the mission.
10. Non-value added processes: Those which support neither the mission of the functional activity, nor mission-supporting requirements established by another functional activity.
11. Limited value added processes: Those which contain non-value added tasks or steps.
12. IDEF Modeling Technique: A combination of graphic and narrative symbols and rules designed to capture the processes and structure of information in an organization. IDEF modeling techniques were derived from the Integrated Computer Aided Manufacturing (ICAM) program sponsored by the U. S. Air Force. The acronym IDEF (pronounced eye-deaf) was formed from the term ICAM Definition Languages.
13. IDEF0: An activity, or behavior, modeling technique.

Specific Problem

The purpose of this research is to document processes in AFIT/RRA as they currently exist, identify areas for process improvement, and propose re-engineering alternatives. After accomplishing these goals, the role of the optical disk storage system will be discussed in conjunction with the re-engineered processes.

Scope of Research

The scope of research for this thesis is to document the processes of the Officer Academic Education Repository Office (i.e., Records Management section) within the Office of the Registrar, which has responsibility for maintaining records on all active duty Air Force officers, as well as Air National Guard and Air Force Reserve officers. The

interactions of this office with their internal and external customers will also be documented. This will include, but is not limited to, the AFIT counselors, the Civilian Institutions Programs office, and the Air Force Military Personnel Center.

Investigative Questions

To address the problem stated above, the following questions will be answered:

1. What are the current processes ("as-is")?
2. What are the activity costs incurred in the processing and handling of education records?
3. What, if any, non-value added processes exist?
4. To what extent can the processes be improved ("to-be")?

After the above questions have been answered:

5. How should the new information technology be integrated to optimize these processes?

Significance of Research

The conclusions reached by this research will provide a business process model, that will attempt to optimize manpower and improve customer service, for AFIT/RR to consider for adoption. The efforts of the thesis team and the functional/technical team could also serve as an example format for conducting BPR studies in the rest of the Office of the Registrar. Additionally, in light of the taskings facing the DoD Universities, these results could serve as a benchmark for subsequent studies.

Preview

Chapter II is a literature review of Business Process Re-engineering and how it has been used by other commercial and DoD functions. In Chapter III, the research methodology will be discussed, followed by Chapter IV which will be an analysis of the data obtained. Conclusions derived from the research and recommendations for additional research are covered in the final chapter, Chapter V.

II. Literature Review

Introduction

The purpose of this literature review is to investigate how BPR has assisted organizations towards success. The scope of this review first covers a discussion on the IDEF0 and Activity Based Costing (ABC) tools used in BPR and then will examine organizations that have incorporated BPR methodologies and the successes or problems experienced as a result of this decision. This will be accomplished by discussing two different viewpoints--those of the business community and the Department of Defense. This review also includes an example of an organization that could benefit from BPR, but currently does not use the methodology.

Business Process Re-engineering and IDEF

Business Process Re-engineering, or FPI within DoD, is a methodology that is used "in analyzing the business process and finding alternatives for improvement" (CIM, 1993:11).

According to the CIM manual, some key elements of BPR are:

- Building a model and establishing cost and performance measures of the baseline to be able to demonstrate improvements.
- Identifying and eliminating non-value added activities.
- Simplifying, integrating, and streamlining value added activities.
- Emphasizing reuse of assets wherever possible.
- Automating only after the underlying business processes have been cleaned up.

- Aligning goals, policies, and procedures within the CIM Integration Architecture (*the reference model that guides all information systems implementation activities providing a strategic framework for making decisions that affect the DoD information infrastructure*).
- Integrating processes, physical assets, organizations, and data as appropriate to gain economies of cumulative volume and limited redundancy. (CIM, 1993:11)

IDEF0 is one of the tools that is used within this methodology. This tool is important because:

. . . [it] was created to define advanced concepts, techniques, and procedures for developing logical models that display semantic characteristics of business transactions and business rules. (Business rules are a set of declarative statements describing the meanings of things and concepts and their relationships within an enterprise.)

Within a business environment, these semantic models support TQM/TQL [Total Quality Management/Total Quality Leadership], business process improvement, management of data as a resource, integration of information systems. . . . The need for semantic models for performance improvement was first recognized by the U. S. Air Force in the mid-1970s as a result of the Integrated Computer-Aided Manufacturing (ICAM) Program. ICAM identified a need for better analysis and communication techniques for improving manufacturing productivity. The objective of ICAM was quite similar to that of CIM; it aimed to improve the manufacturing process through the systematic application of information technology to improved engineering and manufacturing processes. (CIM, 1993:62)

Activity Based Costing, another tool used in BPR ". . . recognizes traditional financial information so that it can be used for decision making by a non-accounting oriented functional manager. Traditional financial information tells managers how they spend money; ABC shows them what they do with the money." (CIM, 1993:12)

Method of Treatment and Organization

The literature review will begin with a discussion of the conditions that motivated the development of BPR strategies in the civilian business community. This will be followed by a similar discussion from the DoD viewpoint. The DoD will be treated separately from the business community as a whole because, although it is in fact a business, it is unique and has only recently been forced to comply with normal business constraints--such as limited budgets and competitors.

Discussion of Literature

The motivation for implementing Business Process Re-engineering stems from a compelling need to re-create the processes of an organization, not simply refine tasks by incremental steps as with methods such as Total Quality Management (Hammer, 1993:30). For many businesses, tasks are conducted with principles and procedures that date back to the Industrial Revolution. These antiquated methods diminish productivity and require the company to re-engineer the way they do business and not simply try to polish outdated methods. The radical changes recommended through BPR encourage organizations not to ". . . pave over the cowpaths, but tear up the road and start over" (Corbin, 1993:26).

Thomas H. Davenport and James E. Short provide the basic concepts of BPR in an article published by the MIT Sloan School of Management, *The New Industrial Engineering: Information Technology and Business Process Redesign*. They believe that organizations are failing because

. . . most processes in major corporations have not been subject to rigorous analysis and redesign. Indeed, many of our current processes result from a series of ad hoc decisions made by functional units, with little attention to effectiveness across the entire process. . . Even fewer business processes have been analyzed with the capabilities of information

technology in mind. Most business processes were developed before modern computers and communications even existed. When technology has been applied, it is usually to automate or speed up isolated components of an existing process. (Davenport, 1990:13)

These organizations use computers to speed up existing processes, "But speeding up those processes cannot address their fundamental performance deficiencies . . . they are geared toward efficiency and control" (Hammer, 1990:104). Today, however, the goals are not efficiency and control, but innovation, speed, service, and quality. Thus, organizations are working toward the wrong goals and they fail to succeed in an environment that increasingly has more competitors, less time to recover from mistakes, and smarter, more-demanding customers.

Scholars agree that BPR can help failing organizations succeed by forcing them to break away from the old rules and ways of doing business and finding imaginative new rules and means. This is the way to achieve large leaps in performance (Hammer, 1990:104). Business Process Re-engineering can assist organizations to "maximize interdependent activities within and across the entire organization . . . [and] develop more flexible, team-oriented, coordinative and communication-based work capability" (Davenport, 1990:12). The business community and the DoD have taken this conceptual foundation and applied it to their real-world situations. These real-world applications highlight the potential values and difficulties of BPR to all businesses.

The business community as a whole agrees that businesses are failing because

. . . we have organized work as a sequence of separate tasks and employed complex mechanisms to track its progress. This arrangement can be traced to the Industrial Revolution, when specialization of labor and economies of scale promised to overcome the inefficiencies of cottage industries. (Hammer, 1990:107)

To achieve these economies of scale

. . . most organizations have organized themselves in vertical functioning groups. Experts of similar background are grouped together to provide a

pool of knowledge and skill capable of completing any task in that discipline. . . . Unfortunately, most work activities do not flow vertically; they flow horizontally. The horizontal workflow and vertical organization result in many voids and overlaps. It encourages sub-optimization, which negatively impacts...the operation. (Harrington, 1991:42)

But,

Japanese competitors and young entrepreneurial ventures prove every day that drastically better levels of process performance are possible. They develop products twice as fast, utilize assets eight times more productively, respond to customers ten times faster. (Hammer, 1990:105)

In order to obtain these levels of process performance several industry leaders such as Ford, Mutual Benefit Life, and Federal Express have undertaken BPR projects with impressive results.

If done correctly, BPR allows managers to break loose from outmoded business processes and paradigms and create new ones. An example of this can be seen in the following case study involving the Ford Motor Company (Hammer, 1993:39-41). In the early 1980s, Ford's North American accounts payable department employed over 500 people. The executives at Ford believed they could reduce the number of employees by 20 percent by integrating automation in the accounts payable department. In accordance with their incumbent TQM methodology, they focused on incremental improvements and were optimistic that they could achieve their goal. While these quality improvements were being implemented, the Ford executives had an opportunity to observe the operations of Mazda's accounts payable department. Although Mazda is a smaller organization, the Ford representatives were shocked to find that Mazda's accounts payable department employed only five people. The dramatic contrasts in department size caused Ford to reconsider their selection of redesign methodology. Mazda recognized the compelling need to totally restructure the way they did business and produced impressive results. Ford made the assumption the accounts payable processes were sound, but the productivity of the various tasks needed improvement (Hammer,

1993:39-41). By incorporating BPR, Ford Motor Company re-engineered its accounts payable processes and was able to achieve a 75 percent reduction in office staff and made material control simpler and financial information more accurate (Hammer, 1990:105).

Prior to re-engineering the processes for handling insurance applications, it took Mutual Benefit Life Insurance Company anywhere from 5 to 25 days to process an application. A typical application was passed between 19 people in 5 different departments. There were over 30 individual steps involved that resulted in processing errors and customer dissatisfaction. The BPR solution to this problem was to abolish departmental boundaries and job definitions and create a new position called "case manager". Individual case managers were assigned responsibility for specific cases, and processed applications from time of receipt to conclusion. Empowering employees with autonomous responsibility produced dramatic results: application time was cut to two to five days and case managers could handle over twice the volume of applications as before (Hammer, 1990:106-107).

Similarly, Federal Express analyzed their delivery process to minimize unexpected disruptions to deliveries. As a result, they developed a new system that "models and predicts incoming package volumes and also considers dynamic criteria such as weather conditions . . . [and now they can] notify the customer [of delays] before the customer calls" (Carr, 1993:59).

One of the goals of BPR is to avoid the suboptimization of processes. One way to avoid suboptimization is for managers to organize work horizontally around outcomes, not tasks (Corbin, 1993:28). An example of the hazards of focusing on tasks is demonstrated in one pharmaceutical company's efforts to abide by the government's process for approving a new drug.

A pharmaceutical company needed field study results on just one week's dosing of thirty different patients. Obtaining this information took the company two years. A company scientist spent four months developing

the study and specifying the kind of data to be collected. Actually designing the study took only two weeks, but getting other scientists to review the design took fourteen. Next, a physician spent two months scheduling and conducting interviews in order to recruit other doctors who would identify appropriate patients and actually administer the trial drug. Collecting the forms that the doctors filled out took two months. Next, the study administrator sent the forms to data entry, where errors were discovered on about 90 percent of them. Back they went to the protocol designer, who sent them to the study administrator, who returned them to the physicians, who tried to correct the mistakes. (Hammer, 1993:10)

This scenario involved several vertically-organized functional groups in the pharmaceutical company that all shared a portion of the process: protocol design, protocol review, study administration, and data entry. The tasks performed by each group were acceptable (within the limited view of each functional group), but because of the vertical orientation, no one held responsibility for conducting the process "field studies", problems in the process were not recognized. By re-engineering this process into a horizontal process, the process owner could conduct or monitor the flow of progress and intervene when necessary. "When one person performs all steps in a process, bottlenecks are eliminated, and work is generally completed in a shorter period of time, with fewer errors and higher overall quality" (Corbin, 1993:28).

When BPR efforts are not successful, the causes are not with the technique itself but due to several external influences (Moad, 1993:23). Contributing factors to failing BPR efforts are "faltering support from upper management, . . . because top management thinks they [projects] involve reengineering when they really don't, . . . and plain old resistance to change" (Moad, 1993:23).

The Department of Defense

"The DoD is currently facing major reductions in resources due to the current shift in national defense strategy" (CIM, 1993:v). The DoD has been a major force in the world with an abundance of resources so there has been a lack of concern for cost

and competition. Now, however, the DoD has officially stated that "the Department must improve the way in which DoD conducts its functions and mission activities to reduce overall costs, provide more use of scarce resources, and better support our joint and combined forces" (DoD 8020.1-M, 1992:8). Vice President Gore is leading the entire federal government along this path as well. He states that we must make a "government that works better and costs less" (Gore, 1993: 124). This is necessary because "the federal government isn't going to get [more money] out of its customers, the taxpayers" (Shoop, 1993:28).

Thinking like a "business" is a new way of operating for the DoD. In doing so, however, the DoD, like industry as a whole, has found that "most [of its] current processes are the products of accretion . . . work methods designed, added to, tweaked, and reconfigured over dozens, sometimes hundreds of years" (Gulden, 1992:10). The DoD cannot sustain a superior world position if it doesn't change with a changing world. As President Clinton stated in his inaugural address, we must "make change our friend" (CIM, 1993:v).

In order to change and improve productivity and regain a position of global leadership the DoD has "committed to achieving the necessary savings through specific programs focused on business process improvement. . . ." (CIM, 1993:v). The DoD has already conducted over 100 BPR projects in fiscal years 1992 and 1993 (Strassmann, 1992:14). The Defense Investigative Agency conducted a BPR study to re-evaluate one of their most time consuming and expensive procedures: security clearances for contractor personnel (Strassman, 1992:14).

Many BPR projects have been facilitated through the use of Integrated Computer Aided Manufacturing Definition languages (IDEF) and Activity Based Costing (ABC) methods, which will be discussed in detail in Chapter III. For example, these methodologies were, and continue to be used by the Department of Defense's service

academies and other degree-granting institutions--the so-called DoD Universities--to improve the way they conduct business. This project was led by representatives from the U. S. Military Academy, U. S. Naval Academy, U. S. Air Force Academy and the Office of the Deputy Assistant Secretary of Defense for Information Management, which sponsors DoD's Functional Process Improvement Program. The DoD Universities project initially targeted the three service academies and the National Defense University, but eventually will cover all the 20 or so degree-granting institutions operated by the military (Moore, 1993:8-9). The service academy portion was broken into segments: financial management, admissions, registrar/student records, development/alumni and facilities/community services. The first area examined and modeled was the financial management operations at West Point. The resulting "as-is" model and proposed "to-be" model led to the recommendation that West Point create an integrated system for their appropriated, non-appropriated and gift financial management. This and other recommendations could generate annual savings of \$1 million according to a preliminary DoD projection (Moore, 1993:9).

Conclusion

This review examined civilian businesses and DoD organizations that have incorporated BPR methodologies and the successes or problems experienced as a result of their decision. In addition, the problems encountered by a pharmaceutical company that did not use BPR were examined. The conceptual foundation for process reengineering was developed by the scholastic world, but the real benefits of BPR were demonstrated by the industrial and corporate domains. Commercial organizations and the DoD have used BPR methodologies to identify outdated processes that served as impediments towards achieving their organizational goals. Business Process Reengineering has failed to help some organizations due to lack of management support,

organizational commitment, and resistance to change. Overall, however, BPR has been able to assist businesses to achieve success. Proponents of BPR are committed to their efforts because they believe BPR "will be a major factor in being competitive in the twenty-first century" (Harrington, 1991:16).

III. Methodology

Introduction

This chapter examines the methodology used to analyze the processes of the Records Management section as they currently exist, identify areas for process improvement and propose re-engineering alternatives. It will begin with the methodology, including an examination of the application and functional/technical team design. Next, the data collection and data analysis plans are covered. Finally, the time constraint for conducting this research and a summary will conclude the chapter.

Methodology

This research effort will apply Business Process Re-engineering to conduct the study. Specifically, IDEF0 will be used to develop activity models and Activity Based Costing (ABC) will be used to provide a quantitative basis for evaluating current and proposed operating methods (DoD 8020.1-M, 1992:52).

Activity modeling, and the use of IDEF0, was chosen as one of the areas of focus for this research because

IDEF0 is a proven technique widely used in government, business, and industry to improve efficiency, improve quality, improve flexibility, and facilitate integration within a functional organization . . . [and] an activity model is used to describe business activities and their relationships. The aim of the IDEF0 activity modeling technique is to support the specification of the positive changes in business processes. . . . A completed activity model graphically depicts the specific steps, operations and information needed to perform an activity. [Also] these models show how specific activities relate to one another. (CIM, 1993:62)

Tying costs to the activities through ABC was chosen as the second focus of this research because ABC can, in concert with IDEF0 activity modeling, be used to enable more effective business process redesign decisions (CIM, 1993:102).

DoD managers need to fully understand the cost, time, and quality of activities performed by people or machines throughout an entire organization if they are to achieve the major goals of business process improvement [or BPR]. ABC methods can enable managers to attach financial measurements to business simplification and process improvement. (CIM, 1993:102)

Applications

The DoD manual, *Functional Process Improvement*, and the *CIM Process Improvement Methodology for DoD Functional Managers* text provide the process improvement modeling steps that will be followed. The following table presents the steps in a BPR study:

TABLE I	
BPR METHODOLOGY SUMMARY	
STEP	TASKS PERFORMED
1	Assemble functional/technical expert team and gather initial data.
2	Establish baseline "as-is" activity model.
3	Validate baseline "as-is" model with functional/technical team.
4	Identify non-value added and limited value added processes.
5	Develop "to-be" activity model and supporting data model.
6	Validate "to-be" model with functional/technical team.
7	Perform Activity Based Costing and link costs to activity models.
8	Eliminate non-value added processes and related activity costs. Streamline limited value added processes and related activity costs.
9	Update baseline "as-is" activity model with each change. Validate changes with functional/technical team.

TABLE 1 (Continued)	
BPR METHODOLOGY SUMMARY	
STEP	TASKS PERFORMED
10	Continue until all non-value added processes are eliminated and streamlining limited value added processes no longer results in significant savings.
11	Streamline all remaining value added processes. Construct new "as-is" activity model.
12	Question existing business assumptions, rules, and procedures and design new "to-be" target model.
13	Develop time-phased implementation plan, measures of activity based cost, and measures of quality, productivity and time-based performance. Validate with functional/technical team.
14	Prepare evaluation, planning and selection documents for improvements alternatives.
15	Prototype improvement alternatives (optional).
16	Prepare preliminary Functional Economic Analysis (FEA), Data Management Plan (DMP), and Technical Management Plan (TMP).
17	Evaluate proposals and prepare final FEA.
18	Approve proposed change. Manage implementation using FEA, DMP, and TMP.

(McDowell and Morgan, 1993:31)

This study will not complete all of the steps, but will focus on those involving activity modeling and ABC, steps 1-13.

As the first step in collecting data for this study, an exploratory set of interviews will be conducted in order to obtain data necessary to establish a tentative baseline "as-is" model and also to provide a background of "technical knowledge" about the organization for the researchers. The instrument chosen to conduct these interviews is a questionnaire adapted from one presented in the book *Business Process Improvement*, by James Harrington, who tested and validated it for his use. The following questions will be asked:

- What are the required inputs?
 - How were you trained?
 - What do you do?
 - How do you know your output is good?
 - What feedback do you receive?
 - Who are your customers?
 - What keeps you from doing error-free work?
 - What can be done to make your job easier?
 - How do you let your suppliers know how well they are performing?
 - How is your output used?
 - What would happen if you did not do your job?
 - Have you reviewed your job description?
 - What would happen if each of your suppliers stopped providing you with input?
 - What would you change if you were the manager?
- (Harrington, 1991:117)

The conclusion of the exploratory interviews will lead into Step 1 from the Methodology Summary chart presented earlier. The functional/technical team will be established from the various activities/offices that participate in the process. As noted by Harrington, the team "is the center of our improvement activity" (Harrington, 1991:62). This team will be the primary source for identifying the inputs, outputs, constraints, mechanisms, and relationships involved in the processes which will be modeled in the IDEF0 format. Figure 1 represents the basics of an IDEF0 model, which is composed of an activity and its related inputs, controls, outputs, and mechanisms (collectively known as "ICOM"). An input is defined as any data or material that is used by an activity to produce an output. A control is any data that regulates or constrains how the activity uses the input. An output is the end product of the input that has been transformed by the activity. A mechanism is any resource (people, machines, or systems) that gives energy to the activity (CIM, 1993:158). This data will be collected by the researchers during weekly meetings with the functional/technical team.

Next, the "as-is" or baseline model will be built from the information collected from the functional/technical team. This model is used to document the processes as they exist from the start date of 3 Mar 94. The baseline process model will be analyzed and validated by the functional/technical teams in an iterative manner. When the team concurs that the developed "as-is" model accurately represents the baseline processes,

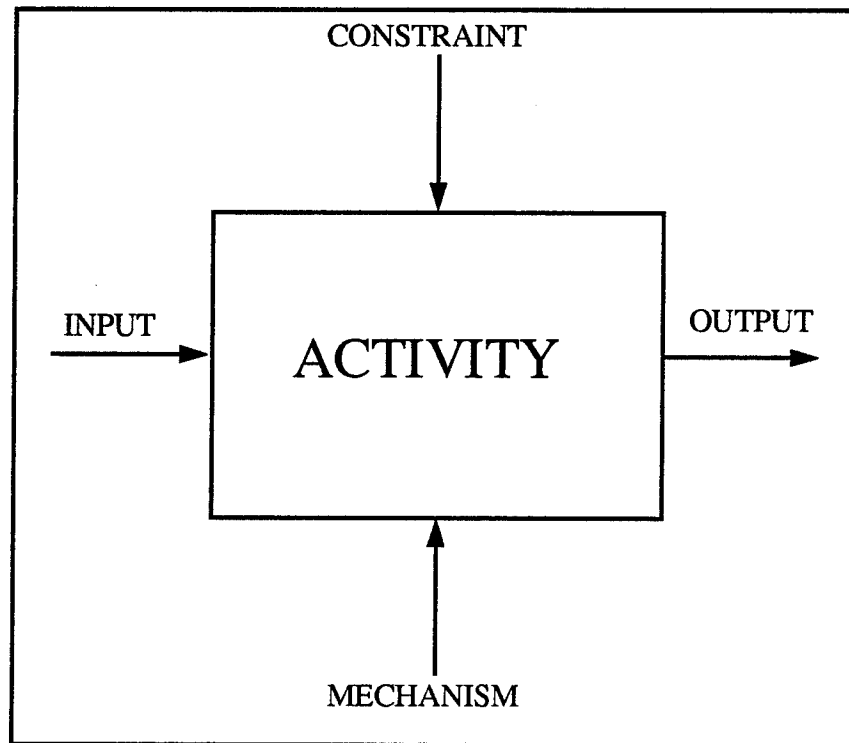

Figure 1. IDEF0 Format

additional information will be collected from the team to assess the Activity Based Costing for managing one education record. This will include determining the average pay rates for the identified cost centers and determining the average time for each process. The team will also be used to identify value added, non-value added, and limited value added processes in the model. Value added processes are those processes that support the mission. Non-value added processes are those which support neither the mission of the functional activity, nor mission-supporting requirements established by

another functional activity. Limited value added processes are those which contain non-value added tasks or steps.

At this point, each proposed process improvement change will be evaluated by the functional/technical team. The value of adding a changed processes to the "to-be" model will be evaluated by the team. Using the information gathered from the team, the activity costs will be compiled and linked to the activity model to support the process re-engineering "to-be" activity model.

Further reviews of the model will then focus on eliminating non-value added processes previously identified and thereby eliminating the related costs. Additional reviews will simplify and streamline the limited value added processes to eliminate their related costs.

The process of developing, validating or revising the model will continue until:

- 1) All non-value added processes are eliminated; and/or
- 2) Further streamlining of limited value added processes involves insignificant savings.

The "to-be" activity modeling will be accomplished using both a different setting and different techniques from those used with the "as-is" modeling. The setting the functional/technical team will use the Group Research Laboratory for Logistics (GRLL) available through Armstrong Laboratory at Wright Patterson AFB, Ohio. The GRLL is a facility created to explore ways to improve the effectiveness and efficiency of various types of group work. It is a conference-type meeting room, with networked computers for up to 15 participants to work together on goal oriented tasks of many types with the aid of a group support system (GSS). A GSS is a combination of networked computers and special software, Group Systems V, that is used in a facility like the GRLL to support group work. Some characteristics of a GSS are:

- The ability to work in parallel. People work in parallel, thus working more quickly while being able to build on each other's ideas.

- The ability to work anonymously. People are thus able to focus attention on what is said, not who said it.

- The ability to record group's work. Complete files are available both as computer files and hard copy.

The GRLL and GSS may provide several benefits like better quality outcome, time savings, fuller participation by group members, and better group buy-in. In addition to the Group Systems V software that is available for the GSS, the GRLL has begun using Group IDEF, a tool that can be used to achieve interactive modeling. The techniques used will be drawn from several proposed in a recent paper, *Business Process Re-Engineering with IDEF and Electronic Meeting Systems*, which was presented at the May 1994 IDEF Users Conference in Richmond, Virginia. This paper proposes the use of

. . . soft thinking [or] highly creative, non-rational, open-ended, and ambiguous [thinking] . . . [and] hard thinking [or] logical, rational, analytical, and precise [thinking] . . . [and] begin with soft thinking followed by hard thinking, because soft thinking is more open-ended and creative. Once the group of experts has become closely focused on the IDEF model, as occurs during hard thinking, it becomes more difficult to move them to more open-ended creative thinking. (Dennis, 1994:100-101)

Although there are several different hard and soft thinking techniques offered in this paper, only one soft thinking technique will be used--*future thinking*.

[With this technique] The group begins by assuming it is the future and that the re-engineering effort has been very successful. They are asked to describe the conditions, either in concrete detail (e.g., what can you see, hear, feel, taste) or by analogy or metaphor. (Dennis, 1994:102)

The use of this technique will constitute one session in the GRLL. The second session will use the newly installed Group IDEF software. The use of the Group IDEF software

to achieve interactive modeling with the functional/technical group will constitute the second and final session at the GRLL.

Team Design

The team will be drawn from the Officer Academic Education Repository office and other process participants throughout AFIT. It will include process experts from AFIT/RRA and the Evaluation and Admissions Division (AFIT/RRE).

Data Collection Plan

As stated previously, data will initially be collected through personal interviews of staff members from the Officer Academic Education Repository Office. These interviews will provide the initial framework for the tentative baseline model and guide the formation of the functional/technical team. Once the functional/technical team is formed, data will be collected through the team for the remainder of the research effort. The functional/technical team will hold regular meetings for data collection and, later, inputs for model validation. Initial data from the team meetings will be used to develop the actual baseline model. Subsequent data will be used to validate the baseline model and initiate revisions. The development, validation, and revision of the baseline model will continue as a loop as the process improvements occur.

Data Analysis Plan

Data analysis will be conducted according to the DoD IDEF0 Modeling guidelines. Validation of the model and revisions will be complete when the functional/technical team achieves consensus. Consensus will be achieved when:

- 1) The majority of the functional/technical team concurs with the proposed

models and/or revisions, and

2) Reasons for non-concurring with the proposed models and/or revisions are found insufficient to dissuade the majority of the functional/technical team from concurring with the proposed changes. (McDowell and Morgan, 1993:37-38)

Time Constraint

A realistic timeline must be established due to the constraints of the thesis process. The interviews, functional/technical team meetings, and corresponding data collection will be allotted six months. At that point, results of the BPR process to date will be compiled, validated with the experts and analyzed. The project is scheduled for completion in mid-August. Any remainder of the BPR process will be recommended for further study.

Summary

This chapter examined the methodology used to analyze the processes that are presently occurring within the Officer Academic Education Repository Office. Standard DoD BPR methodology using IDEF0 and ABC was chosen to conduct this research. Data collection and data analysis plans were presented to establish procedures according to the DoD BPR methodology. Finally, a timeline for conducting the research was presented to allow for data compilation and presentation.

IV. Data Analysis

Introduction

This chapter presents the data compiled during the six month time period allotted for the research. The presentation will begin with coverage of the composition of the functional/technical team, the objectives of the AFIT Officer Academic Education Repository's records management process as identified by the functional/technical team and the baseline "as-is" modeling. Later sections concern Activity Based Costing (ABC), "to-be" modeling and IDEF0 modeling where "as-is" modeling and ABC data are linked. Finally, the data related to some of the investigative questions will be addressed.

Functional/Technical Expert Team

Business Process Re-engineering--and specifically the IDEF modeling tool--used for this study requires the knowledge and cooperation of the "process experts." In theory it would be valuable to obtain inputs from all process experts, but in practice this is not always feasible. The acting AFIT Registrar--and subsequently the new incumbent Registrar--with the guidance of the Chief, Officer Academic Education Repository Office--as the research sponsors provided insight in choosing which process experts were best qualified, and available, for the functional/technical team. The Registrar recommended that the team be composed of process experts from the Officer Academic Education Repository Office and other process participants throughout AFIT. The team eventually included process experts from AFIT/RRA and the Evaluation and Admissions Division (AFIT/RRE).

Initial functional/technical team meetings identified the objectives of the Officer Academic Education Repository's records management process and produced the baseline "as-is" model.

Objectives of the Records Management Process

Initially, an exploratory set of interviews were conducted in order to collect data necessary to obtain a tentative understanding of the objectives of the records management process. The instrument chosen to conduct these interviews was a questionnaire adapted from one given in the book, *Business Process Improvement*, by James Harrington, who tested and validated it for his uses. The results of these interviews are listed in Appendix F. The results of the exploratory interviews concluded that the objectives of the Officer Academic Education Repository's records management process were to uphold its responsibilities in maintaining records on all active duty Air Force officers, as well as Air National Guard and Air Force Reserve officers.

Baseline "As-Is" Modeling

Baseline "as-is" modeling was accomplished on a large, classroom-type, dry erase board that was positioned at the front end of a large conference table. This positioning enabled facilitated communication and participation among the team members and made changes and updates quick and easy for the facilitators. The baseline "as-is" model initially identified three activities in the records management process shown in Table 2.

After several subsequent meetings to further define this process, the functional/technical team identified sub-activities, and other further decompositions, for the three initial activities. These sub-activities, and some further decompositions, are also shown in Table 2. Once the baseline "as-is" modeling was completed, the current processes were documented and defined.

TABLE 2

INITIAL BASELINE "AS-IS" ACTIVITIES AND SUB-ACTIVITIES

ACTIVITY	SUB-ACTIVITIES
CONTROL RECORDS	<ul style="list-style-type: none"> Retrieve Records Create/Correct Records <ul style="list-style-type: none"> Establish Physical Record Correct Record Update Data in PDS Refile Records Distribute Records <ul style="list-style-type: none"> Place in "In-Basket" Place in Staging Area
MAINTAIN RECORDS	<ul style="list-style-type: none"> Counseling Services <ul style="list-style-type: none"> Record Screening Record Evaluation Status Check Prepare Outgoing Mail Coding <ul style="list-style-type: none"> Board Updates Student Status Updates New Records Accession AD Record Updates Guard/Reserve Updates Process HPSP Selections
PROVIDE CUSTOMER SERVICE	<ul style="list-style-type: none"> Inquiry Assessment On-the-Spot Inquiry <ul style="list-style-type: none"> Retrieve Record Pull SURF Answer Inquiry Resolution of Referral <ul style="list-style-type: none"> Reviews Need Research Available References

Activity Based Costing

Activity Based Costing (ABC) is one of the tools used in BPR that ". . . recognizes traditional financial information so that it can be used for decision making by a non-accounting oriented functional manager" (CIM, 1993:12). Used in conjunction with the IDEF0 models, ABC ". . . provides functional users with the capability to characterize the value of, or need for, each activity...[by]determining the cost of business outputs" (CIM, 1993:102). As applied to the BPR project conducted for the AFIT Records Management section, ABC was used to determine the costs associated with the "as-is" processes identified by the functional group. The processing and handling of a single education record was used as the cost driver. In order to determine this cost, several factors must be included in the calculation. These factors include identifying the process time duration, determining the process frequency, identifying pay grades, and identifying cost centers.

Process Time Duration

The time duration for each process was based on information from the functional group and on times extracted from the 1992 Air University manpower study. The significant portions of the manpower study are included in Appendix B. The duration times are represented in average total minutes required to complete each process. The times were entered into the IDEF ABC function for each process (Table 5).

Process Frequency

The majority of processes apply to all education records; however, for those processes that applied to only a portion of records, the frequency multiplier option was used to assign an accurate cost to the process. For example, approximately 50 percent of the education records are processed by the Selections section. When the costs are

calculated by the IDEF software, the duration (137 minutes) is multiplied by the cost center rate (\$0.23). The product is then multiplied by the frequency (50 percent of education records processed) to arrive at the total cost of \$15.76 per record.

Pay Grades

The military and civilian pay rates used were based on the rates listed in AFR 177-101, *General Accounting and Finance Systems at Base Level* and the *GS Hourly Pay Rate Table, 1993*. The applicable hourly wage rates were converted into minute equivalents, and are listed in Table 3.

TABLE 3 Hourly Pay Rates		
Pay Grade	Hourly Rate	Minute Rate (rounded to 0.01)
E-3	\$11.81	\$0.20
E-4	\$14.18	\$0.24
E-5	\$17.20	\$0.29
GS-4/Step 6	\$9.16	\$0.15
GS-4/Step 7	\$9.42	\$0.16
GS-5/Step 10	\$11.42	\$0.19
GS-7/Step 9	\$13.79	\$0.23
GS-9/Step 4	\$14.65	\$0.24
GS-11/Step 4	\$17.72	\$0.30
GS-12/Step 6	\$22.53	\$0.38

(AFR 177-101, 1993:337; Office of Personnel Management, Hourly Pay Rate Table, 1993)

Cost Centers

The IDEF ABC function requires the identification of "cost centers" for calculation of costs. In this project, the cost centers are defined as either the person or persons primarily responsible for performing a particular process. Six different cost

centers were identified during the "as-is" modeling process. In most cases, these are functional areas that perform processes unique to their area. For example, within Counseling Services, there are two counselors who divide the workload. In order to arrive at a pay rate for each cost center, an average rate was calculated by dividing the sum of the pay rates for all personnel performing the process by the number of personnel involved. The following example demonstrates how the average pay rate for the Counseling Services cost center was calculated:

Cost Center Pay Rate Calculation:

	Pay grade	Minute rate
	GS-9/Step 4	\$0.24
	GS-11/Step 4	\$0.30
Totals	2 personnel	\$0.54

Cost Center pay rate: $\$0.54/2 = \0.27

This information plus the other five cost centers are listed in Table 4.

TABLE 4		
COSTS CENTERS		
Cost Center	Pay Grades	Cost Center Rate
Administration	E-4, E-5, GS-4/Step 6, GS-4/ Step 7	\$0.21
Coding	E-3, E-4, E-5	\$0.24
Counseling Services	GS-9/Step 4, GS-11/Step 4	\$0.27
Counseling Services Secretary	GS-5/Step 10	\$0.19
Chief of Counseling Services	GS-12/Step 6	\$0.38
Selections	GS-7/Step 9	\$0.23

The IDEF program calculates the total cost of higher level activities by "rolling-up" the costs of the sub-activities at each layer. The total cost calculated for the Manage Education Records process therefore is an aggregate of all its sub-activities and totals \$69.95 per education record. Table 5, presented on the following page, expands the

initial baseline "as-is" activities and sub-activities identified in Table 2 to indicate the associated cost centers and the costs.

TABLE 5				
INITIAL BASELINE "AS-IS" ACTIVITIES AND SUB-ACTIVITIES				
ACTIVITY	SUB-ACTIVITIES	DURATION	COST CENTER	COST
CONTROL RECORDS		<u>38.8 min.</u>		<u>\$8.21</u>
	Retrieve Records	3 min.	Coding	\$0.63
	Create/Correct Records	25.5 min.		\$5.43
	Establish Physical Record	21.5 min.	Admin	\$4.50
	Correct Record	1 min.	Coding	\$0.21
	Update Data in PDS	3 min.	Coding	\$0.71
	Refile Records	3 min.	Admin	\$0.63
	Distribute Records	7.3 min.		\$1.52
	Place in "In-Basket"	2.3 min.	Admin	\$0.47
Place in Staging Area	5 min.	Admin	\$1.05	
MAINTAIN RECORDS		<u>234.5 min.</u>		<u>\$57.75</u>
	Counseling Services	113 min.		\$29.27
	Record Screening	4 min.	Secretary	\$0.76
	Record Evaluation	84 min.	Couns Serv	\$22.69
	Status Check	7 min.	Couns Serv	\$1.89
	Prepare Outgoing Mail	18 min.	Couns Serv/ Sec	\$3.93
	Coding	53 min.		\$12.72
	Board Updates	16 min.	Coding	\$3.84
	Student Status Updates	9 min.	Coding	\$2.16
	New Records Accession	9 min.	Coding	\$2.16
	AD Record Accession	4 min.	Coding	\$0.96
	Guard/Reserve Updates	6 min.	Coding	\$1.44
	Process HPSP	9 min.	Coding	\$2.16
Selections	137 min. (times 50% frequency)	Selections	\$15.76	

INITIAL BASELINE "AS-IS" ACTIVITIES AND SUB-ACTIVITIES (Continued)				
ACTIVITY	SUB-ACTIVITIES	DURATION	COST CENTER	COST
PROVIDE CUSTOMER SERVICE		15.5 min.		\$3.99
	Inquiry Assessment	3 min.	Admin/ Couns Sec	\$1.20
	On-the-Spot Inquiry	7 min.	Admin	\$1.47
	Retrieve Record	3 min.	Admin	\$0.63
	Access Computer	3 min.	Admin	\$0.63
	Answer Inquiry	1 min.	Admin	\$0.21
	Resolution of Referrals	5.5 min.	Admin/ Coding/Select /Couns Serv	\$1.32

"To-Be" Modeling

Traditionally, the "to-be" modeling is developed entirely by the functional group using a methodology similar to the "as-is" modeling. This involves group discussion and consensus of how processes should be changed, if at all. The traditional approach was the intended methodology for developing the "to-be" model for the Manage Education Records process, however several factors arose that altered this initial plan. During the final "as-is" development sessions, it seemed to the thesis team that the functional group was losing interest in the project. This conclusion was based on the failure of several group members to consistently attend meetings. Another difficulty encountered was a change in group membership due to the retirement and reassignment of two members, and only one member was replaced. The poor attendance and attrition of group members created a loss of continuity and a lack of understanding of IDEF modeling for the replacement member.

For these reasons, and to help expedite the "to-be" modeling process, an alternate plan was selected. This involved two group sessions at the Armstrong Laboratory Group Research Laboratory for Logistics (GRL). The focus of the first group session was to develop a vision of future processes. On the basis of this data, the thesis team developed the "to-be" model. The "to-be" model would then be entered into the Group IDEF program for presentation and refinement by the group at the second group session.

Prior to convening the group at GRL, the thesis team and Mr. Randy Baker from the Registrar's Office met with the GRL facilitator, Dr. Alan Heminger, to discuss a strategy for the group session. The decisions made during the pre-planning meeting are described in the discussion of the group sessions that follows.

The first session involved seven members from the AFIT Registrar's Office (four original functional group members, one functional group member replacement, and two interested parties (the AFIT Registrar and the Chief of Counseling Services)). The group session was facilitated by Dr. Alan Heminger. On the basis of the "future thinking" concept suggested by Alan Dennis, the group was told to assume that it is a year in the future and that the BPR effort has been completed (Dennis, 1994:102). The Group Systems V group support system software available at the GRL was selected for this session because it allowed the collection ideas through anonymous brainstorming. Dr. Heminger opened the brainstorming session by posing the question: "Imagine it's 1995 and all the things you wished for have come to pass. What are they? What has changed? Don't worry about how to make it happen, just explain what has happened." Anonymous comments were entered by the individual participants at their workstations using the "Topic Commentor" function. Using this function, participants entered as many comments as they wanted, and they could read and respond to other anonymous comments entered into the system. The initial brainstorming phase lasted approximately

20 minutes and concluded when each participant indicated that they were done (either verbally or by being idle for several minutes).

At the conclusion of the initial brainstorming phase, Dr. Heminger assisted the group in consolidating the inputs by eliminating duplicate topics and combining related topics. The refined list was then divided into two categories:

List A: "Items that will happen regardless." These processes were identified by the group as items that the group had no influence over because they were already scheduled to happen.

List B: "Need to make this happen." These processes were identified as items that would require a change in the existing process structure. Table 6 is the refined list of items generated by the group during the initial brainstorming phase and divided by the group into the two lists (items not presented in any rank order).

TABLE 6	
SESSION I--GROUP COMMENTS	
List A: "Items that will happen regardless"	List B: "Need to make this happen"
Optical disk records are operational	Counseling teams are functioning well
Education records are updated with less steps	Have all computer systems within AFIT user-friendly
Optical record displays official transcript copy	Ability to receive information comments from the schools
	Computer related training is increased
	Staff members support new technology
	More ADAMS workstations
	Improve telephone process
	Staff levels have increased to the level needed to accomplish document conversion to optical disk

The second brainstorming phase began with Dr. Heminger asking the group to provide anonymous comments in response to the question: "What needs to happen to make List B a reality?". The Topic Commentor function was again used and idea

generation lasted for approximately 30 minutes and concluded when participants indicated verbally that they were finished or they were observed as being idle for several minutes. This phase generated many comments, which are listed in Table 7.

The comments are presented as they were entered by the participants, with corrections made for spelling . Each bullet indicates the comments entered by one participant.

TABLE 7	
SESSION 1--EXPANDED GROUP COMMENTS: LIST B	
List B Item	Anonymous comments
Counseling teams are functioning well	<ul style="list-style-type: none"> - Composed of one counselor, one coder and one admin person. - We'll need training in group dynamics, goal setting, interpersonal conflict resolution. - Train all parties on the complete purpose of actions, not just their own input. - Need more counselor to process the heavy workload and telephone calls. - Everyone needs to be able to work together and also need to be in one work area. Train everyone as to what they are expected to do. We need one extra person to pick up the slack and help wherever they are needed. - Need to update all continuity books, OIs, etc. These are years old and different personnel are doing the functions differently. - It is vital that ALL personnel doing the same function be trained to do it the same way. - Work together as a team and be sensitive to one another. For example if someone is not feeling well be a little more kind and patient than you would normally be. - It will be necessary to streamline the work so that if a team member is absent, the equivalent member from the other team picks up for the day. - Need to work out duties of each team member, responsibilities of the team leader and all members of the team. - Need to explore ways to streamline evaluation process. Perhaps move some programs...CI for those programs that are only offered in civilian institutions, perhaps have students obtain admission independently. Ed offices could assist more in evaluation process with training.

List B Item	Anonymous comments
Counseling teams are functioning well, (continued)	<ul style="list-style-type: none"> - The one problem with moving the evaluation process is records. If something like this was done, CI would have to have ADAMS. I don't like moving the evaluation process to all bases - lack of continuity. - Although there is a Reduction-In-Force taking place, there is not a reduction in workload. Let's make sure we have enough people to do the job and do it right the first time.
Have all computer systems within AFIT user-friendly	<ul style="list-style-type: none"> - Have computers up and running all the time. Too often the computers are down - and even with the limited computer use of today it becomes a work stoppage. If we use even more computer programs to do our work (i.e. ADAMS), there will be days nothing gets done and it will put us even further behind. - Request that SC not implement new software just because it's new. We seem to be in a constant "learning curve." Just when we begin to learn the present system they "upgrade," change, etc.; and we go back to "square one." - Currently, information (class rosters) for PCE transcribing is located in several locations within AFIT. The use of processing paperwork instead of using available computer systems is time consuming and possibly more errors. - Automation is wonderful; however, the limitations we encounter when the computer system is not functioning can really impact the accomplishment of our mission. Is it possible to have a back up system? How would this work? I've been close to panic when I've needed to print a document that I will need in a short while and the printers aren't working or the server is down. What's the answer? Is it all or nothing? - Redundancy is built in our system. Not all computers are connected to the AFIT network. Some printers, Betty's, Randy's, Maria's, Cel's will work regardless of network status.
Ability to receive information comments from the schools	<ul style="list-style-type: none"> - The schools can offer guidance via computer instead of hard copy. - Would help us communicate with faculty members who are assisting us in the evaluation of students' records; would save time and perhaps minimize misunderstandings. - Conference calls via e-mail or phone for review of problem evaluations. And or program changes or updates. - Begin by meeting various faculty members personally and then begin communicating through e-mail, fax, telephone, etc.

List B Item	Anonymous comments
Computer related training is increased	<ul style="list-style-type: none"> - It is vital to know how to use the tools. I recommend more and increased length of computer training. Often the 1 or 2 days are just enough to frustrate a person - not encourage them to use the computer. - Agree. Hands on training in the office is important. - Perhaps staff members could volunteer to become the resident "expert" in a particular application and serve as coach/trainer for the rest of the staff. - Agree with this. More training is needed. - Once trained will be able to use the training.
Staff members support new technology	<ul style="list-style-type: none"> - Staff members have to be comfortable with new technology before they can support it. Much training is going to be required on the new technology as well as being kept informed on the changes, how its going, etc. Frequent updates are needed. - We need to demonstrate to the staff that the new technology will help them do their job better before we can expect their support. - Show staff how technology can make their job easier and faster - Need updates from the Optical Disk team on how it appears to be working - are transcripts readable, what is the time line till we can work on ADAMS, what transcripts will be entered first, etc. - Have personnel involved in the whole process of setting up system. So the individuals have a chance to have in-put as the system develops not after the fact. That way they may bring out things that are important to their specific area of focus, that programmer, consultant might not have been aware of, or might not have realized the importance of. - It would very helpful to contract out the initial process of loading the education records into optical disk. - I agree, this would assist the implementation and user ability of the system more quickly. - Contracting out is the ideal solution. We are limited by the availability of funds...it's VERY expensive.

List B Item	Anonymous comments
More ADAMS workstations	<ul style="list-style-type: none"> - I would want to be careful before we give CI and the schools access to ADAMS. All RR needs trained on this before moving to other areas. - I'm not sure I know what ADAMS is. - What would the schools and CI do with ADAMS? How will it help them/us? - Currently a paper folder is moved to CI for CI programs. Thus, they will need access to the electronic record - Do the schools really need ADAMS with the fax involved? Could we not just pull up the record and fax it to them. SAVES \$\$. - In order to fax the record on line, the schools and specific faculty members would need to have the capability in their computers. Or do you mean to fax a hard copy? - RE: Schools need ADAMS? Fax could work for them, however they have the basic platform needed (a 486 computer) for ADAMS - RE: Hard copy? In-system fax to computer screen would be best. Hard copy an alternative for those who do not have SatisFaction software - I thought we could fax the record from the screen to any fax number and they received a hard copy
Improve telephone process	<ul style="list-style-type: none"> - Have the telephone system designed to direct phone calls to the appropriate section. - Limit phone calls to certain processes; require others to come through e-mail or fax. - We don't want to go to voice mail! - I agree!!! Voice mail is very frustrating and ineffective. I would not want to make our customers as angry and frustrated as I get when I call other AFIT shops who have voice mail. I want a human being to direct my calls. - Email/Fax addresses instead of so many telephone calls. - Telephone calls currently control our day. If we could correspond with the officers by either Email or fax, we could control when our routine work permitted correspondence with officers. - Students should be able to call their local or base education office for information concerning their education records. - The e-mail/fax connection is excellent; it would permit us to establish priorities more efficiently as well as providing better answers to officers' questions.

List B Item	Anonymous comments
Improve telephone process (continued)	<ul style="list-style-type: none"> - Would like to see the telephones cut down to only 3 lines. - 3 lines would not handle all the calls - thus decrease of customer service. We'd have to have another method of correspondence before this could happen, i.e. Email or fax. - Would an answering service be helpful - something like we had a few years ago - but maybe put some options on - if counseling or coding is needed. - No, the answering service just placed a large call back list on the sections, often spending hours trying to reach the officer. FAX or Email is better. - There is too much information in RR, coding, medical, civilians, registrar, etc. to use this type of answering service. I think it would only frustrate the customer and make us look bad. - I agree, this is one area in which automation hinders communication instead of helping.
Staff levels have increased to the level needed to accomplish document conversion to optical disk	<ul style="list-style-type: none"> - Shifting personnel to met the actual needs of work flow. Train people in more than one area, so there is flexibility in how they can be used. - Since we know we won't be getting additional manpower, we'll need to take a long, hard look at the entire RR staff and see where we can save steps and manpower to augment other areas that need more help. - Cross-training in diverse functions would help, so that when one area's workload is lighter, these persons can help in other areas. - Teamwork will be very important.

The final task for the group was to rank order the eight items in List B based on two criteria, importance and easiest to make changes in order to adopt. The Group Systems V software has the ability to collect and sort the anonymous votes made by the participants. The results of the first voting session, rank ordering based on degree of importance, are as follows: (Items sorted by total descending order):

- 1 Counseling teams are functioning well
- 2 Staff levels have increased to accomplish document conversion to optical disk
- 3 Improve telephone process
- 4 Staff members support new technology

- 5 Computer related training is increased
- 6 Have all computer systems within AFIT user-friendly
- 7 Ability to receive information comments from the schools
- 8 More ADAMS workstations

The results of the second voting session, rank ordering based on ease of implementation, are as follows (in descending order):

- 1 Computer related training is increased
- 2 Ability to receive information comments from the schools
- 3 Staff members support new technology
- 4 Improve telephone process
- 5 More ADAMS workstations
- 6 Counseling teams are functioning well
- 7 Staff levels have increased to accomplish document conversion to optical disk
- 8 Have all computer systems within AFIT user-friendly

On the basis of the data gathered during the first group session at the GRLI and the observations made during the "as-is" modeling, the thesis team then developed a set of "to-be" model for the group to review and refine at the second GRLI session. The Group IDEF software contained no supporting documentation on its use and proved to be extremely difficult to manipulate. After several hours of experimentation, the thesis team was able to enter the developed "to-be" model, but the graphic layout was very cluttered and confusing and concerns arose about presenting the model to a group who were novices to IDEF modeling. The thesis team decided to present the group with the Group IDEF node tree option that displays the processes and their associated ICOMs in an outline format.

The decision to proceed with this option turned out to be academic because the second group meeting was never held. All attempts to reconvene the group failed, and after spending a month trying to coordinate the meeting, the thesis team was advised to try a different course of action for validating the "to-be" model. This involved meeting individually with as many of the original functional group members to collect his/her comments on the "to-be" model. After attempting to schedule one-on-one meetings with

three of the group members, only one member was available for model validation. She validated the model developed by the thesis team with one minor change. The "to-be" model validated by the group member, with her minor change, is presented in Appendix D.

Investigative Questions

During the initial phase of identifying the specific problem to be addressed by this thesis research, a set of five investigative questions were developed as guidelines for conducting the research. The following section provides responses to these questions. As previously stated, the data collected was not complete, and therefore some questions must be left unanswered by this research effort.

Investigative Question 1: What are the current processes ("as-is")?

The current processes identified and validated by the functional team have been divided into three activities: Control Records, Maintain Records, and Provide Customer Service. These activities and their sub-activities are listed in Table 2 and are represented through IDEF0 modeling in Appendix A.

Investigative Question 2: What are the activity costs incurred in the processing and handling of education records?

The activity costs were calculated using the AFR 177-101, *General Accounting and Finance Systems at Base Level* and the *GS Hourly Pay Rate Table, 1993*. The pay rates of the personnel involved in each activity were combined to develop an average pay rate for the cost center. The cost center pay rates were multiplied by the duration times for each activity to develop the activity cost. Tables 3, 4, and 5 detail these calculations and Appendix A displays the activity costs with the IDEF0 model.

Investigative Question 3: What, if any non-value added or redundant processes exist?

This question was not addressed by the functional team due to time constraints.

Investigative Question 4: To what extent can the processes be improved ("to-be")?

As previously discussed, the functional group was unable to reconvene to develop the "to-be" model. The "to-be" IDEF0 model presented in Appendix D was developed by the thesis team and validated by only one functional team member.

Investigative Question 5: How should the new information technology be integrated to optimize these processes?

Due to the fact that the optical record storage technology was being installed while the "as-is" and "to-be" models, it was not possible to re-engineer processes prior to integrating new technology, as recommended by BPR experts. As a result, the "to-be" model in Appendix D primarily reflect changes that occurred due to the newly installed optical record technology and not through the identification of non-value added processes.

Summary

This chapter presented the data compiled during the six month research period. The composition of the functional/technical expert team was discussed, as well as the objectives of the records management process. The evolution of the baseline "as-is" model was outlined, with expanded explanations of how the Activity Based Costing results were calculated. The alternative methodologies selected for the "to-be" modeling were discussed and the results of the functional team session held at the Group Research Laboratory for Logistics were provided. This chapter concluded by answering the investigative questions presented in Chapter I, when possible.

V. Conclusions and Recommendations

Introduction

This chapter presents the conclusions and recommendations stemming from this research. The conclusion section discusses the outcomes of the Business Process Re-engineering effort with respect to the investigative questions. Also, a discussion of problems encountered during the research that had a direct impact on the overall study is included in this section. The recommendations section details suggestions for further research as well as addressing BPI methodology.

Conclusions: Lessons Learned

An analysis of the difficulties encountered during the BPR effort reveal a variety of situations that occurred over the entire course of the study. Each problem would not necessarily degrade the success of a BPR effort on its own, however the combination of these problems occurring during this study proved to be detrimental to completing the re-engineering project. The identification of these pitfalls is important to possibly facilitate future BPR efforts. The following discussion categorizes the problems encountered during specific stages of the study.

Exploratory Interviews. Before establishing the functional team and launching into the "as-is" modeling, the thesis team conducted exploratory interviews with all assigned personnel to become familiar with the mission and duties of the Records Management section. It was during these interviews that it became clear that there were several personnel problems inherent in the section. Overall, the personnel interviewed believed that they were overworked and undermanned, and our presence was viewed as a distraction. One individual spent more time explaining to us why they didn't have the time to answer our questions than it took to answer the questions. As a result, the

information collected during this interview was not particularly useful. Another individual openly expressed their dissatisfaction with their job and co-workers. This overt negativism carried over to their participation on the functional team and resulted in little or no meaningful contributions. There also seemed to be problems between the Records Management section and other co-located sections stemming from perceived inequities of the responsibilities assigned to each section. This resentment at first inhibited the interactions of the functional group members, and it was difficult to tell whether a suggestion was made with re-engineering goals in mind or simply to unload some of the work to another section. Over time, however, a positive outcome was detected by the Registrar who noticed better working relations between the sections, which she contributed to the participation in the weekly functional group meetings.

The information gathered during the exploratory interviews was also intended to allow the thesis team to develop a skeleton "as-is" model to use as a foundation for initiating the functional group meetings. The data collected was useful, but not entirely conducive to model building due to a failure to gather some key elements. The interviews introduced the thesis team to the daily processes at a very macro level, but due to our ignorance of the processes, it was difficult to know what questions to ask to draw out more information. On the other hand, because the interviewees perform the processes dozens of times everyday, it was easy for them to forget bits of information or to leave out information because it seemed too trivial.

Functional/Technical Team. The functional team is one of the most important factors contributing to the success (or failure) of a BPR effort. While this BPR effort had the support of the Registrar, there was no BPR "champion" to communicate the importance of the project and to ensure all team members were able to attend every meeting. The onus for generating enthusiasm and communicating the importance of the study was on the thesis team. Additionally, the functional team must believe their ideas

could have an impact on the future design of the organization. This belief did not exist in this functional group, which is possibly one reason why they lost interest in the study.

The team saw that the integration of the new optical disk storage system was a foregone conclusion, so it was difficult for them to envision the future (and the present tense) without including the technology when developing the IDEF models. James Harrington states that the members of the functional team must possess process knowledge, process ownership, and the power to change the process (Harrington, 1991:46-47). The members of the Records Management team were assigned based on availability and did not meet Harrington's criteria. This frequently resulted in inaccurate information and a lack of participation by those who did not feel qualified to offer inputs. The composition of the team changed frequently due to reassigned personnel and absences due to illness, authorized leave, and heavy workload. Every time a new member joined the team, time had to be taken away from model production to quickly teach the newcomer how to interpret the IDEF models. This resulted in a loss of continuity and momentum that hindered progress and over time affected the team's interest in completing the study.

"As-Is" Baseline Modeling. At the initial functional team meeting the thesis team explained the purpose and methodology of the planned BPR effort. It was explained that the current date would be used as the baseline for modeling the "as-is" processes. As the weeks progressed, the processes of the Records Management section changed periodically as a result of managerial decisions made outside the BPR effort. These frequent changes made it difficult for the functional team to develop the "as-is" model based on the original starting date. This problem was further confounded by the addition of new (and occasionally transient) team members who were new to the organization and did not have knowledge of the baseline processes.

At every weekly meeting the functional team was presented copies of the IDEF model developed by the thesis team based on the previous week's discussion. The

intention was to have the team validate or change the model, but the validation varied every time the group's composition varied. After several months, the team was able to arrive at a consensus of the "as-is" model, which is presented in Appendix A.

"To-Be" Modeling. Due to our perceived decrease of interest in the BPR effort by the functional team, an alternate plan for developing the "to-be" model was chosen. Additionally, during the initial team meetings, the thesis team stressed the importance of disregarding the recent acquisition of the optical record storage technology when developing the "as-is" and "to-be" models. The optical record technology was in the process of being purchased and installed during the "as-is" modeling and some team members occasionally tried to include the developing technology in the model. In spite of warnings from BPR experts to automate only after re-engineering was completed, the existence of the new technology could not be ignored and modeling the "to-be" processes around it could not be avoided. As a result, many of the re-engineered processes are not truly re-engineered, but simply reformatted to include the optical records technology.

Recommendations

Even though the data collected was insufficient to meet the goals of the thesis, valuable insight for conducting other Business Process Re-engineering efforts has been presented to assist any future BPR project. A careful review of the methodology presented and the "Lessons Learned" section could prevent similar outcomes. Within the AFIT domain, the efforts put forth by the thesis team and the functional team have attracted the interest of the AFIT Registrar, who is interested in sponsoring future BPR projects for the other sections under her supervision.

Additionally, a continuation of this thesis research is highly recommended. Given the foundation provided by this study, further exploration of the following incomplete Investigative Questions could be undertaken:

Investigative Question 3: What, if any non-value added or redundant processes exist?

Investigative Question 4: To what extent can the processes be improved ("to-be")?

Investigative Question 5: How should the new information technology be integrated to optimize these processes?

The most important factor that can be recommended as a result of this thesis study is to confirm sponsorship from top management prior to launching into a BPR effort. If possible, it would be beneficial to make the sponsor a member of the thesis committee or in some way a more integral thesis team member. Again, it must be stressed that it is mandatory for top management to confirm their pledge of support, communicate the importance of the study to all involved, and to ensure dedicated involvement of personnel assigned to the functional team. Failure to establish these requirements from the onset will increase the potential for failure.

Summary

This chapter presented the conclusions and recommendations drawn from this research. The conclusions were presented in the form of "Lessons Learned", and were categorized by the specific stage of the study. The recommendations were presented with respect to BPR efforts in general, and with respect to follow-on research for this thesis study.

Appendix A: IDEF0 "AS-IS" Model with Costs

This IDEF0 model shows the costs associated with each activity to manage each education record. Costs for each lowest-level activity are automatically combined to attain the activity costs for their parent.

USED AT:	AUTHOR: Capt Hutchinson/Capt McCoy PROJECT: AFIT/RA	DATE: 26 September 1994 REV:	WORKING DRAFT	READER	DATE	CONTEXT:
NOTES: 1 2 3 4 5 6 7 8 9 10			RECOMMENDED			Top
			X PUBLICATION			

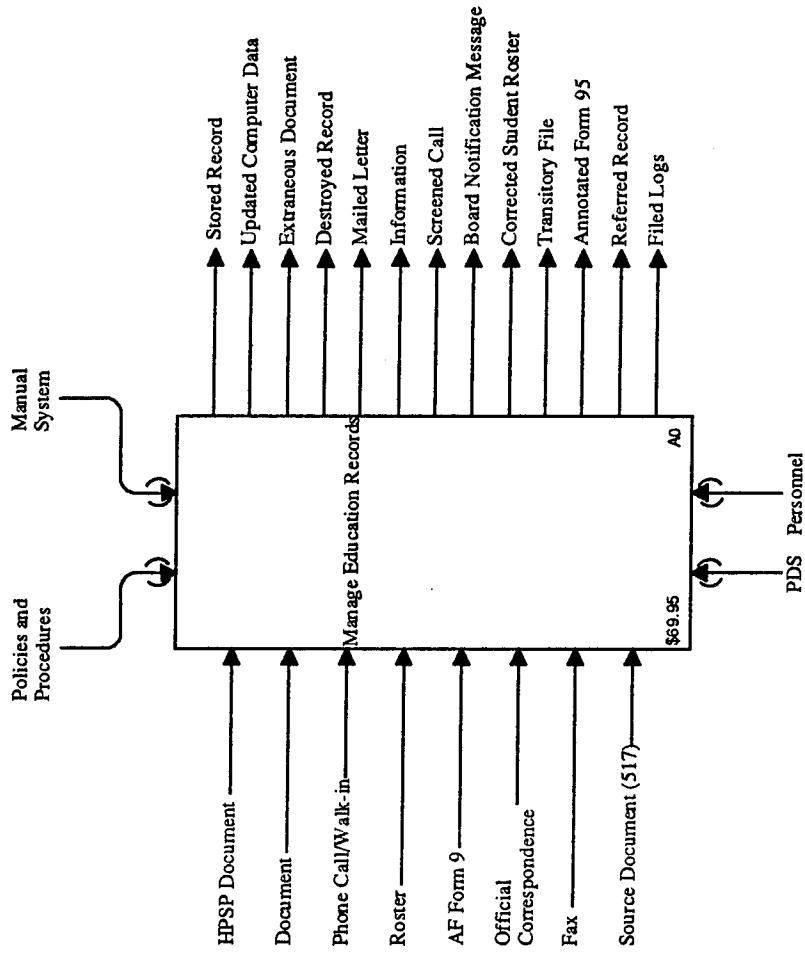

Viewpoint: Chief, Officer Academic Education Repository

NODE: A-0	TITLE: Context Diagram	NUMBER:
-----------	------------------------	---------

USED AT:	AUTHOR: Capt Hutchinson/Capt McCoy	DATE: 26 September 1994	READER	DATE	CONTEXT:
PROJECT: AFIT/RA	REV:		WORKING		
NOTES: 1 2 3 4 5 6 7 8 9			DRAFT		<input type="checkbox"/>
			RECOMMENDED		<input type="checkbox"/>
			X PUBLICATION		<input type="checkbox"/>

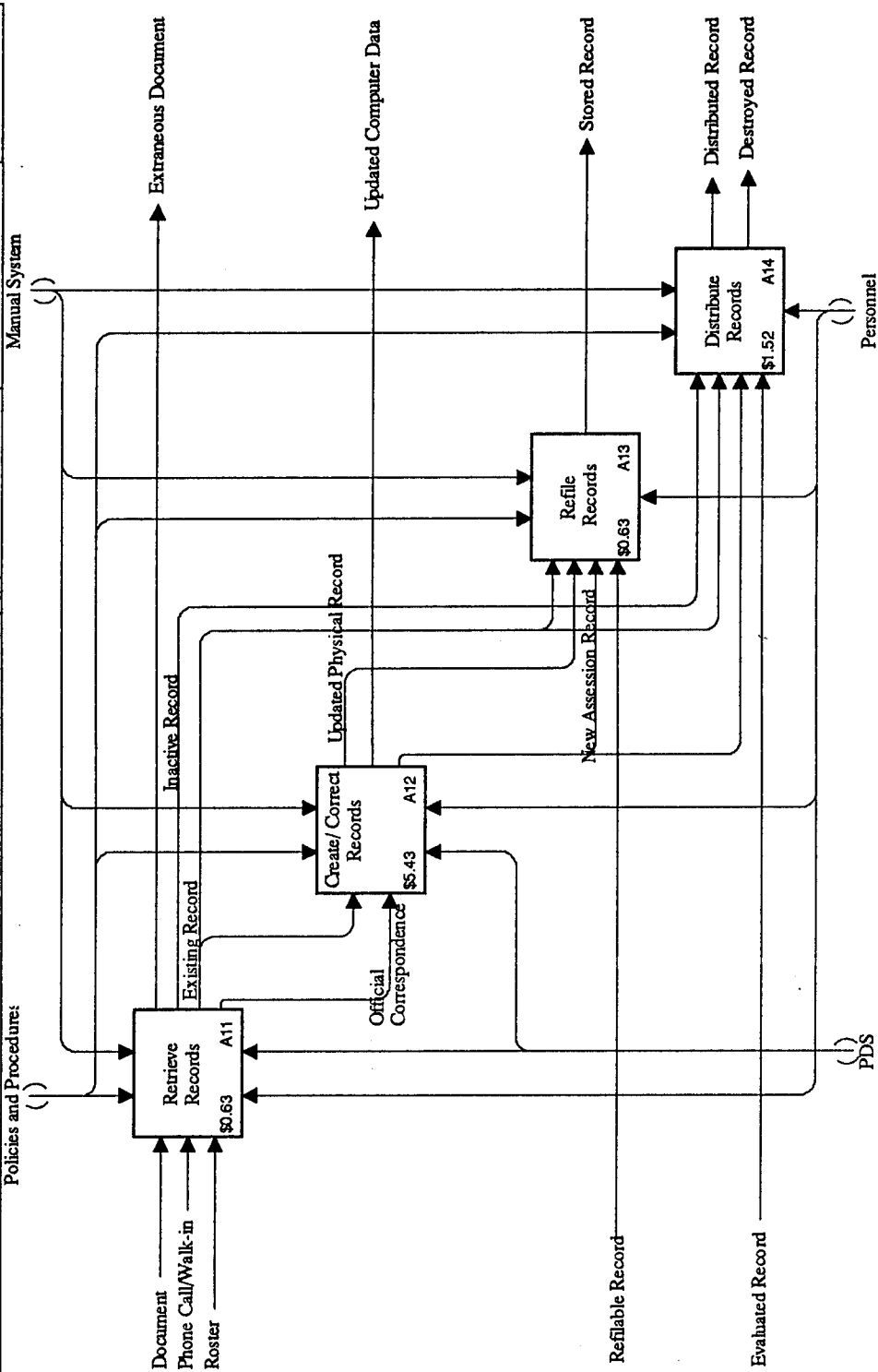

NODE: A1	TITLE: Control Records
	NUMBER:

USED AT:	AUTHOR: Capt Hutchinson/Capt McCoy	DATE: 26 September 1994	READER:	DATE:	CONTEXT:
PROJECT: AFT/RRR	REV:		WORKING		<input type="checkbox"/>
NOTES: 1 2 3 4 5 6 7 8 9			DRAFT		<input type="checkbox"/>
			RECOMMENDED		<input type="checkbox"/>
			PUBLICATION	X	<input type="checkbox"/>

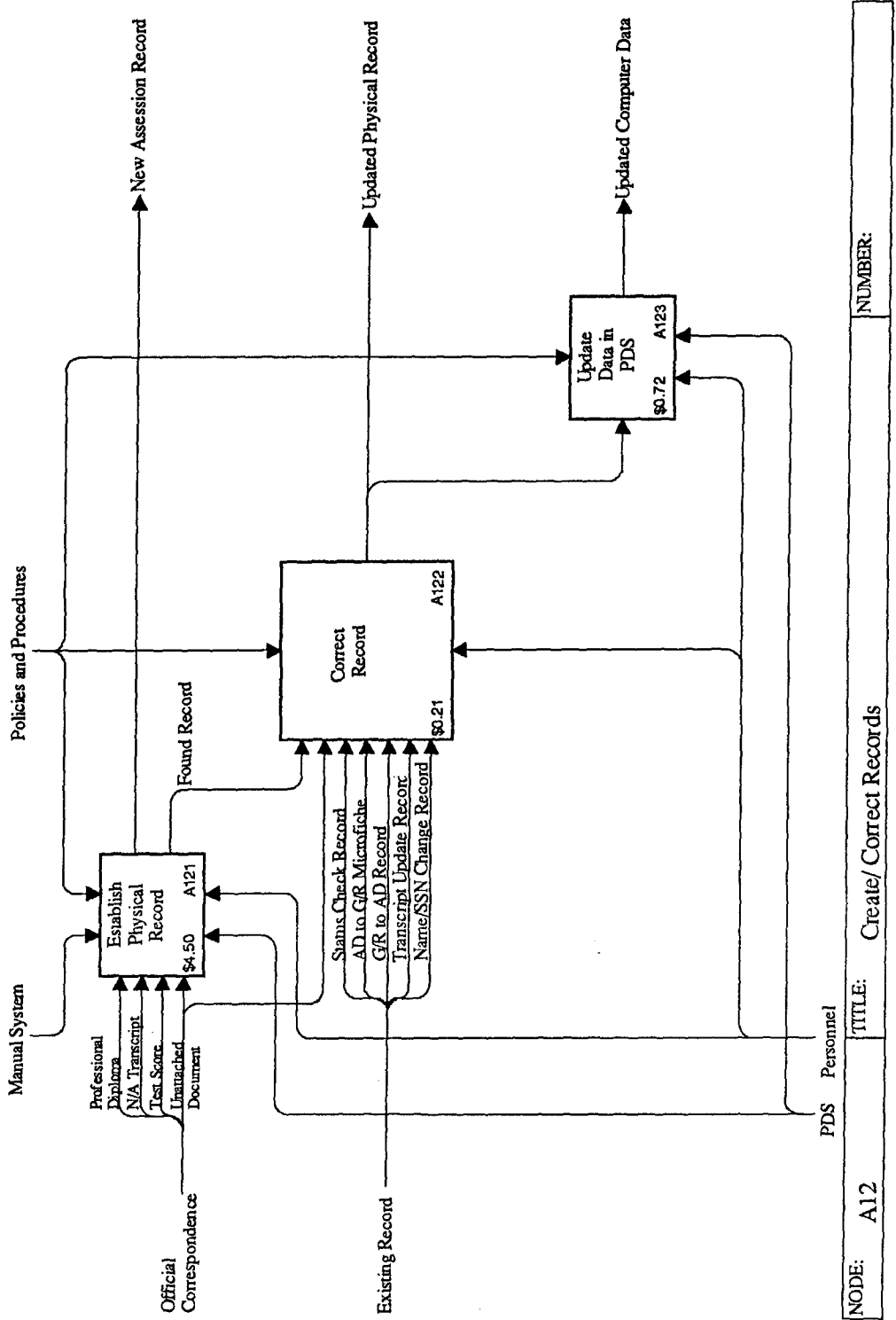

NODE: A12	TITLE: Create/Correct Records	NUMBER:
-----------	-------------------------------	---------

USED AT:	AUTHOR: Capt Hutchinson/Capt McCoy	DATE: 26 September 1994	WORKING	READER	DATE	CONTEXT:
PROJECT: AFTI/RA	REV:		DRAFT			<input checked="" type="checkbox"/>
NOTES: 1 2 3 4 5 6 7 8 9			RECOMMENDEI			<input type="checkbox"/>
			X PUBLICATION			<input type="checkbox"/>

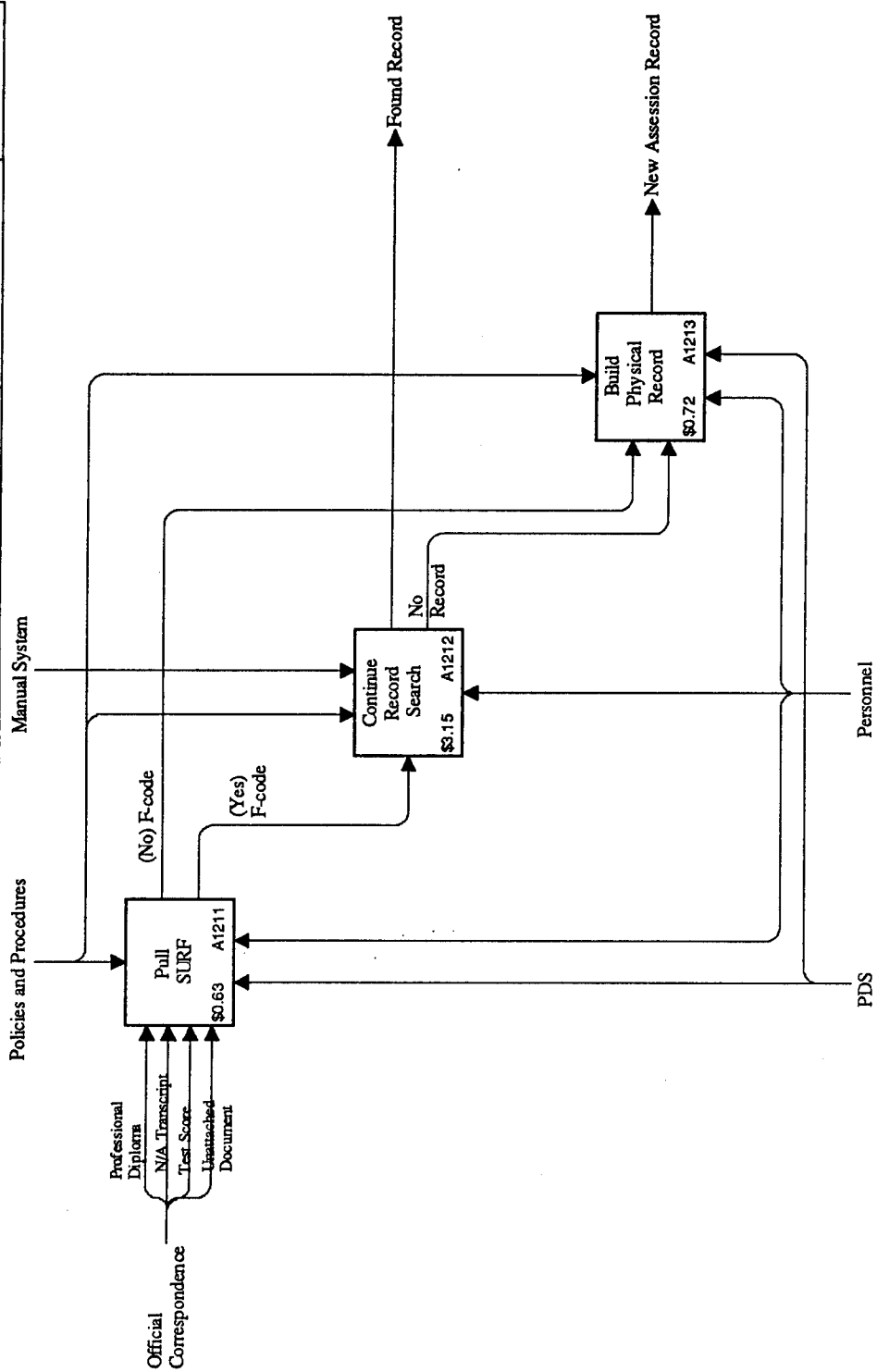

NODE: A121	TITLE: Establish Physical Record	NUMBER:
------------	----------------------------------	---------

USED AT:	AUTHOR: Capt Hinchinson/Capt McCoy	DATE: 26 September 1994	WORKING	READER	DATE	CONTEXT:
	PROJECT: AFTT/RRA	REV:	DRAFT			<input type="checkbox"/>
	NOTES: 1 2 3 4 5 6 7 8 9		RECOMMENDED			<input type="checkbox"/>
			PUBLICATION			<input checked="" type="checkbox"/>

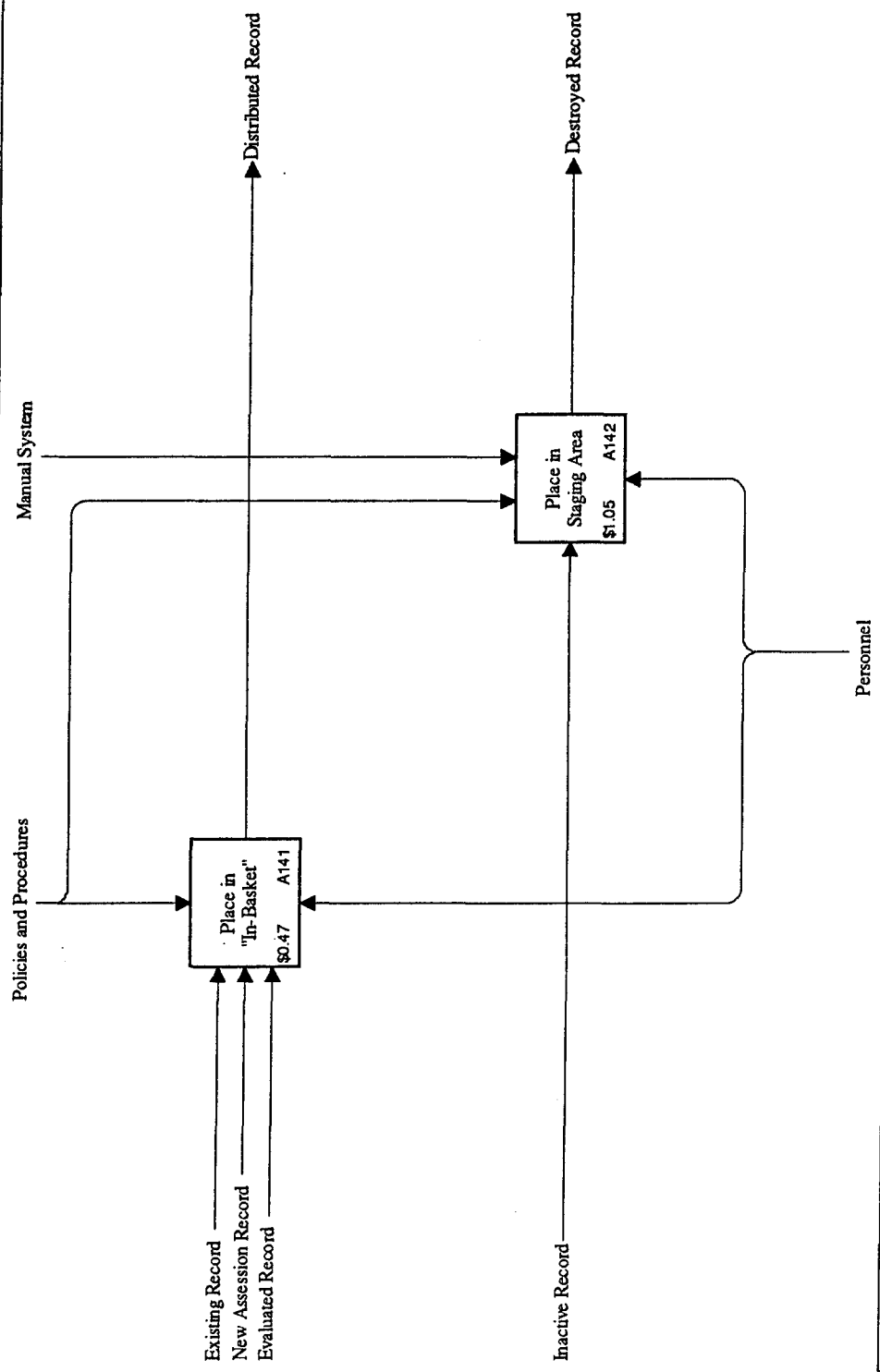

NODE: A14	TITLE: Distribute Records	NUMBER:
-----------	---------------------------	---------

USED AT:	AUTHOR: Capt Hutchinson/Capt McCoy	DATE: 26 September 1994	WORKING	READER	DATE	CONTEXT:
PROJECT: AFT/RA	REV:		DRAFT			<input type="checkbox"/>
NOTES: 1 2 3 4 5 6 7 8 9			RECOMMENDED			<input checked="" type="checkbox"/>
			X PUBLICATION			<input type="checkbox"/>

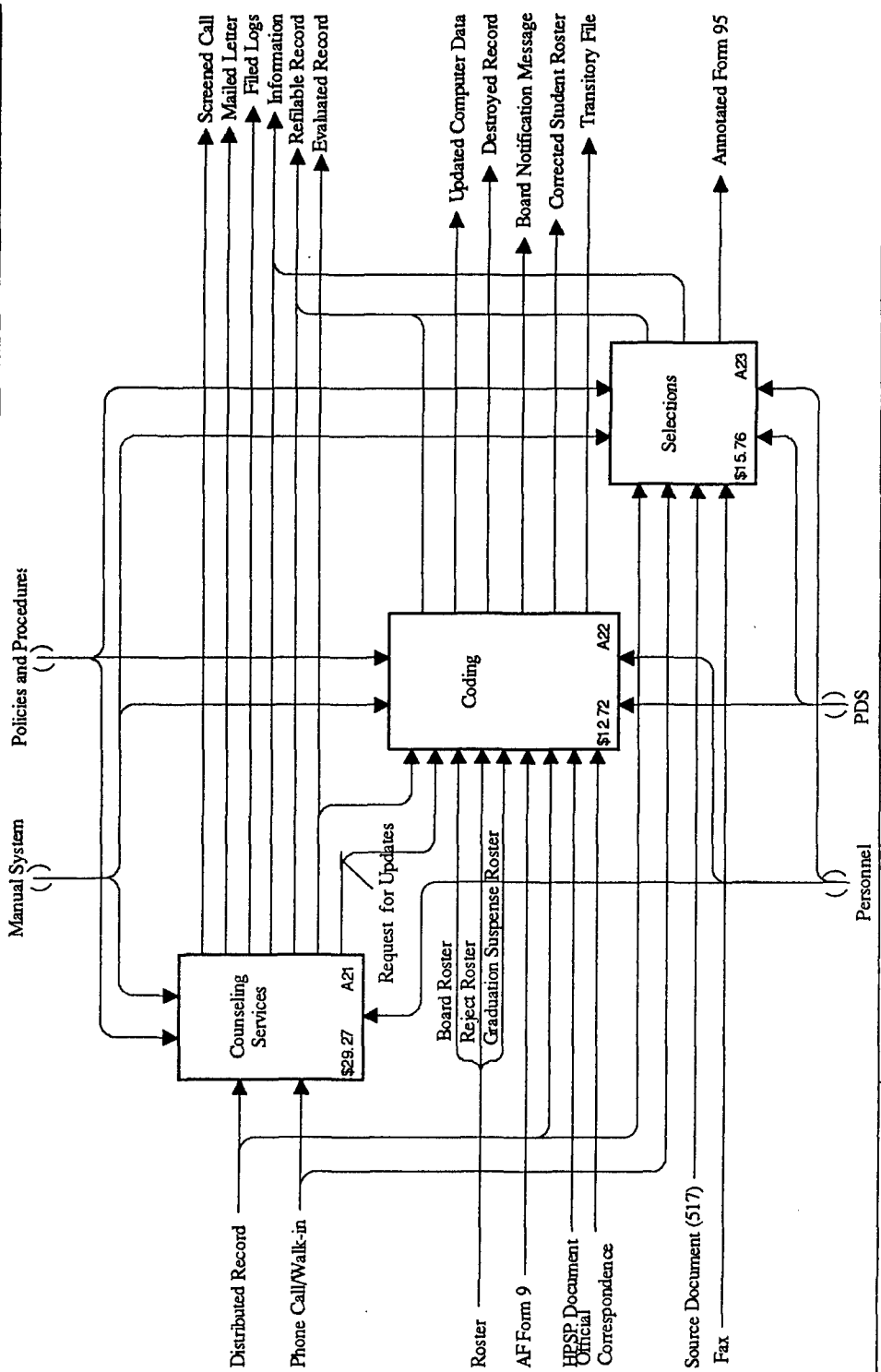

NODE: A2	TITLE: Maintain Records	NUMBER:
----------	-------------------------	---------

USED AT:	AUTHOR: Capt Hutchinson/Capt McCoy	DATE: 26 September 1994	WORKING	READER	DATE	CONTEXT:
PROJECT: AFIT/RRR	REV:		DRAFT			<input type="checkbox"/>
NOTES: 1 2 3 4 5 6 7 8 9			RECOMMENDEL			<input type="checkbox"/>
			X PUBLICATION			<input type="checkbox"/>

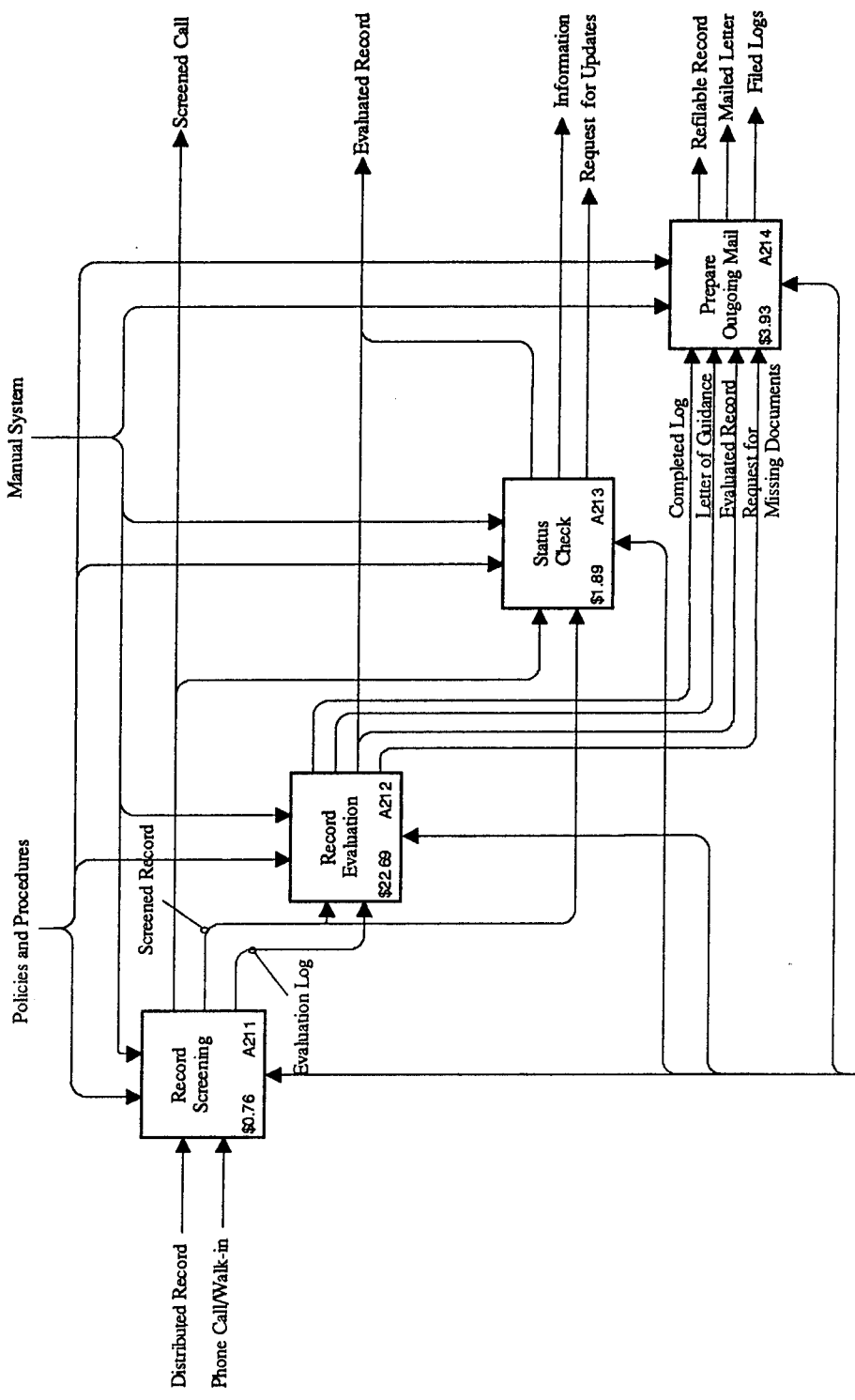

PERSONNEL	TITLE: Counseling Services	NUMBER:
NOTE: A21		

USED AT:	AUTHOR: Capt Hutchinson/Capt McCoy	DATE: 26 September 1994	WORKING	READER	DATE	CONTEXT:
PROJECT: AFT/RRR	REV:		DRAFT			<input type="checkbox"/>
NOTES: 1 2 3 4 5 6 7 8 9			RECOMMENDED			<input type="checkbox"/>
			X PUBLICATION			<input type="checkbox"/>

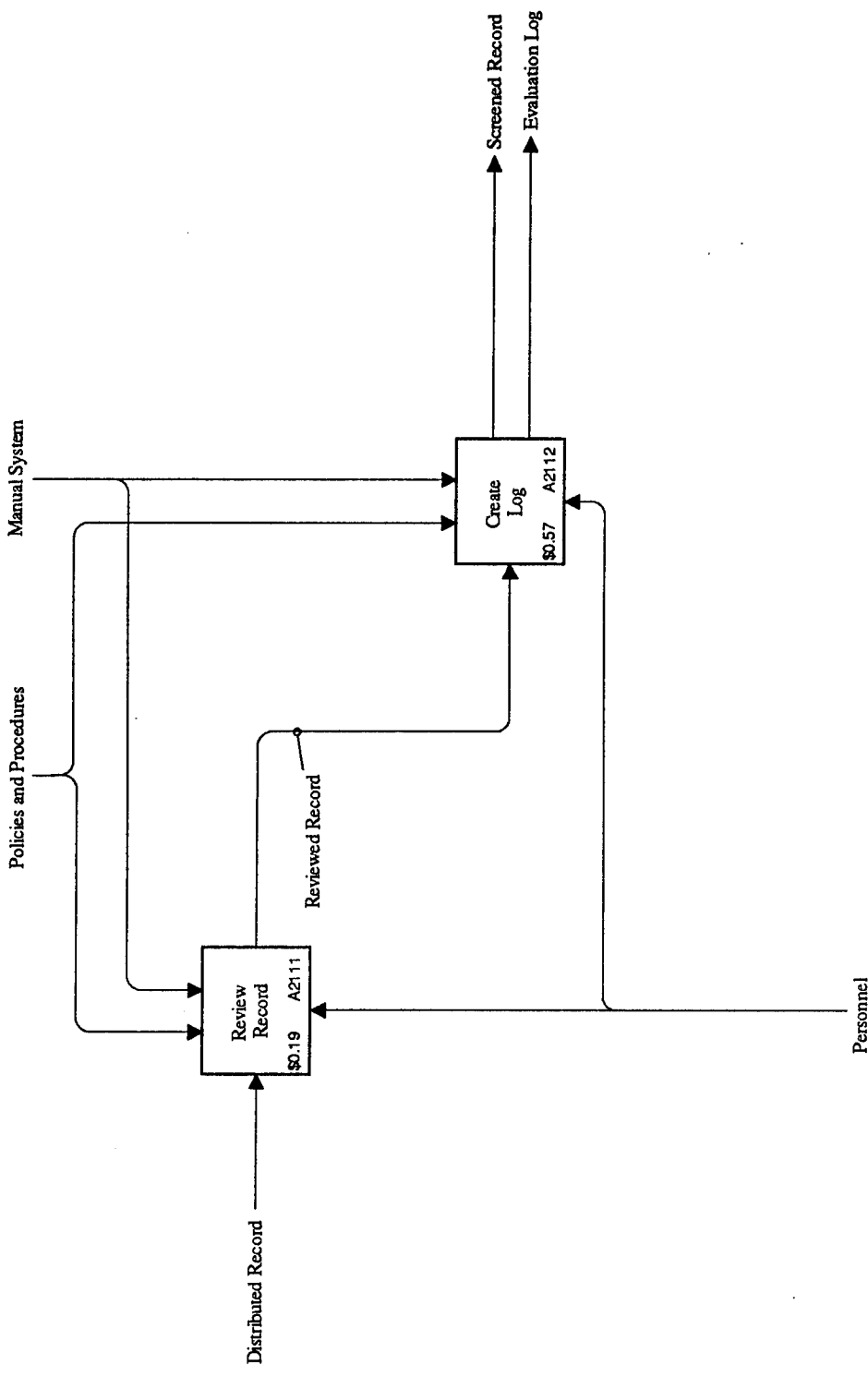

NODE: A211	TITLE: Record Screening	NUMBER:
------------	-------------------------	---------

USED AT:	AUTHOR: Capt Hutchinson/Capt McCoy	DATE: 26 September 1994	READER	DATE	CONTEXT:
PROJECT: AFIT/RRR	REV:		DRAFT		<input type="checkbox"/>
NOTES: 1 2 3 4 5 6 7 8 9			RECOMMENDED		<input type="checkbox"/>
			X PUBLICATION		<input type="checkbox"/>

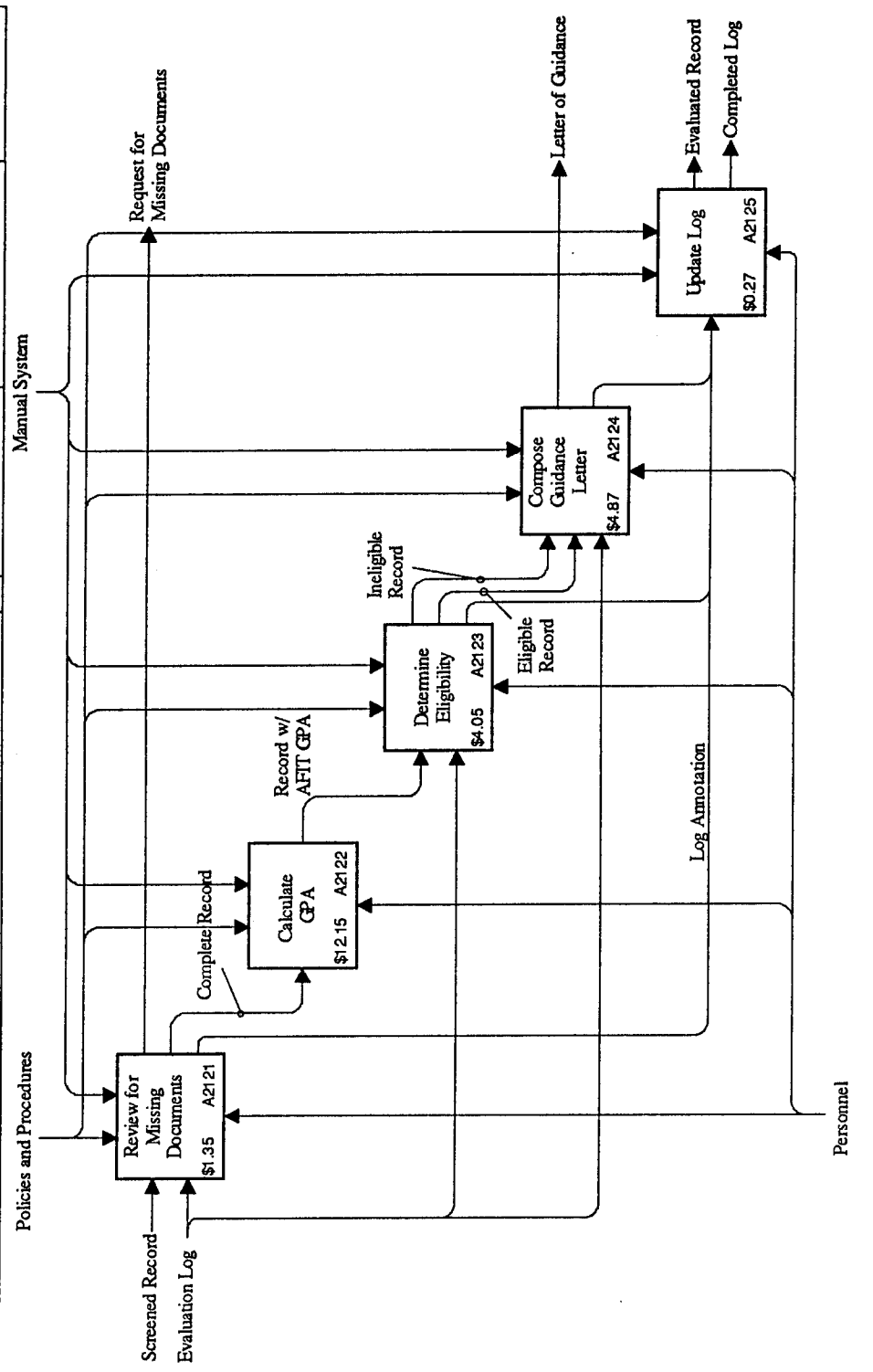

NODE: A212	TITLE: Record Evaluation	NUMBER:
------------	--------------------------	---------

USED AT:	AUTHOR: Capt Hutchinson/Capt McCoy PROJECT: AFTI/RAA	DATE: 26 September 1994 REV:	WORKING DRAFT RECOMMENDEC PUBLICATION	READER	DATE	CONTEXT:
NOTES: 1 2 3 4 5 6 7 8 9			X			<input type="checkbox"/> <input type="checkbox"/> <input checked="" type="checkbox"/> <input type="checkbox"/>

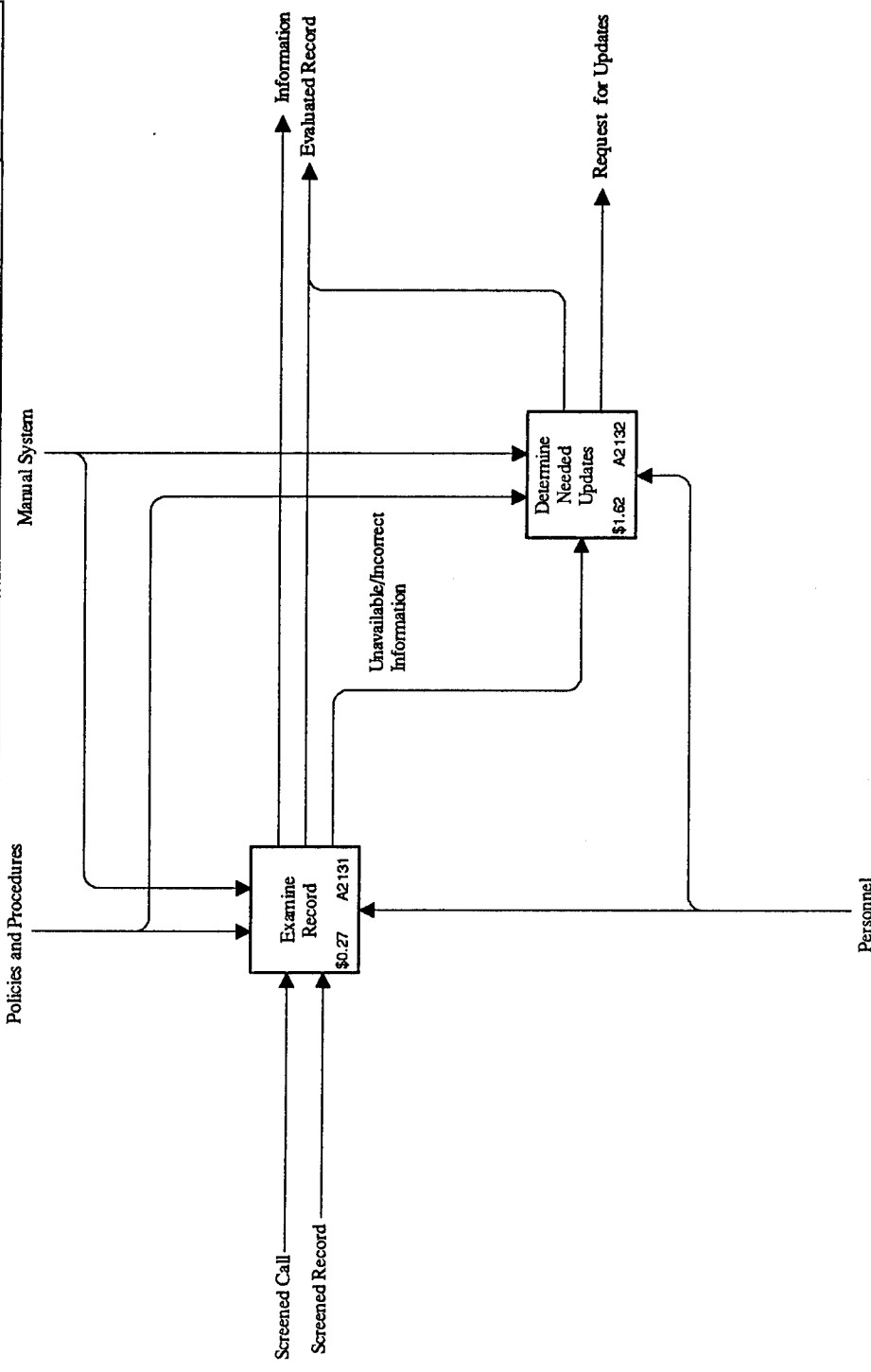

NODE: A213	TITLE: Status Check	NUMBER:
------------	---------------------	---------

USED AT:	AUTHOR: Capt Hutchinson/Capt McCoy	DATE: 26 September 1994	WORKING	READER	DATE	CONTEXT:
PROJECT: AFIT/RRR	REV:		DRAFT			<input type="checkbox"/>
NOTES: 1 2 3 4 5 6 7 8 9			RECOMMENDED			<input type="checkbox"/>
			X PUBLICATION			<input checked="" type="checkbox"/>

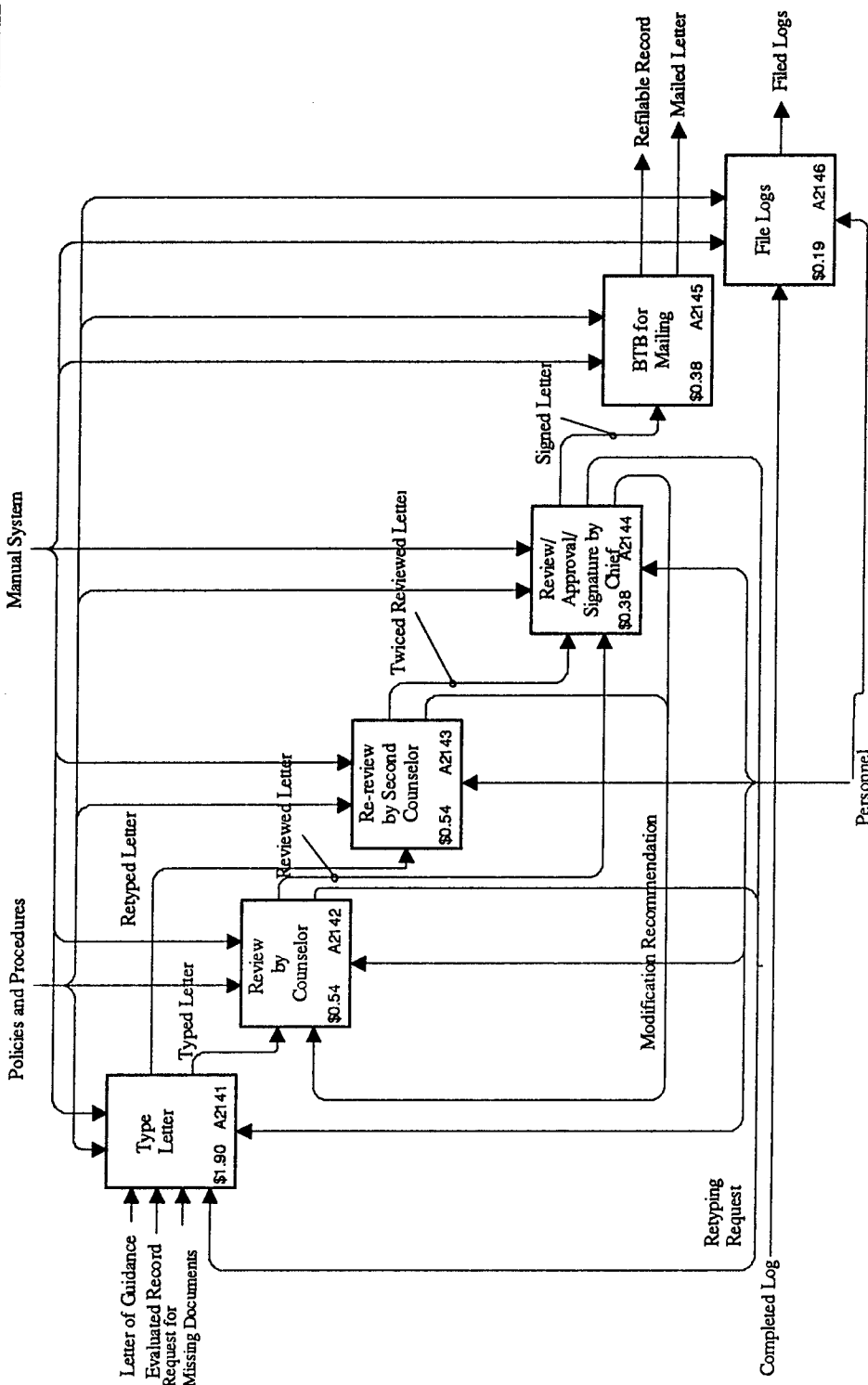

NODE: A214	TITLE: Prepare Outgoing Mail	NUMBER:
------------	------------------------------	---------

USED AT:	AUTHOR: Capt Hutchinson/Capt McCoy	DATE: 26 September 1994	WORKING	READER	DATE	CONTEXT:
PROJECT: AFIT/RA	REV:		DRAFT			<input type="checkbox"/>
NOTES: 1 2 3 4 5 6 7 8 9			RECOMMENDEE			<input type="checkbox"/>
			X PUBLICATION			<input type="checkbox"/>

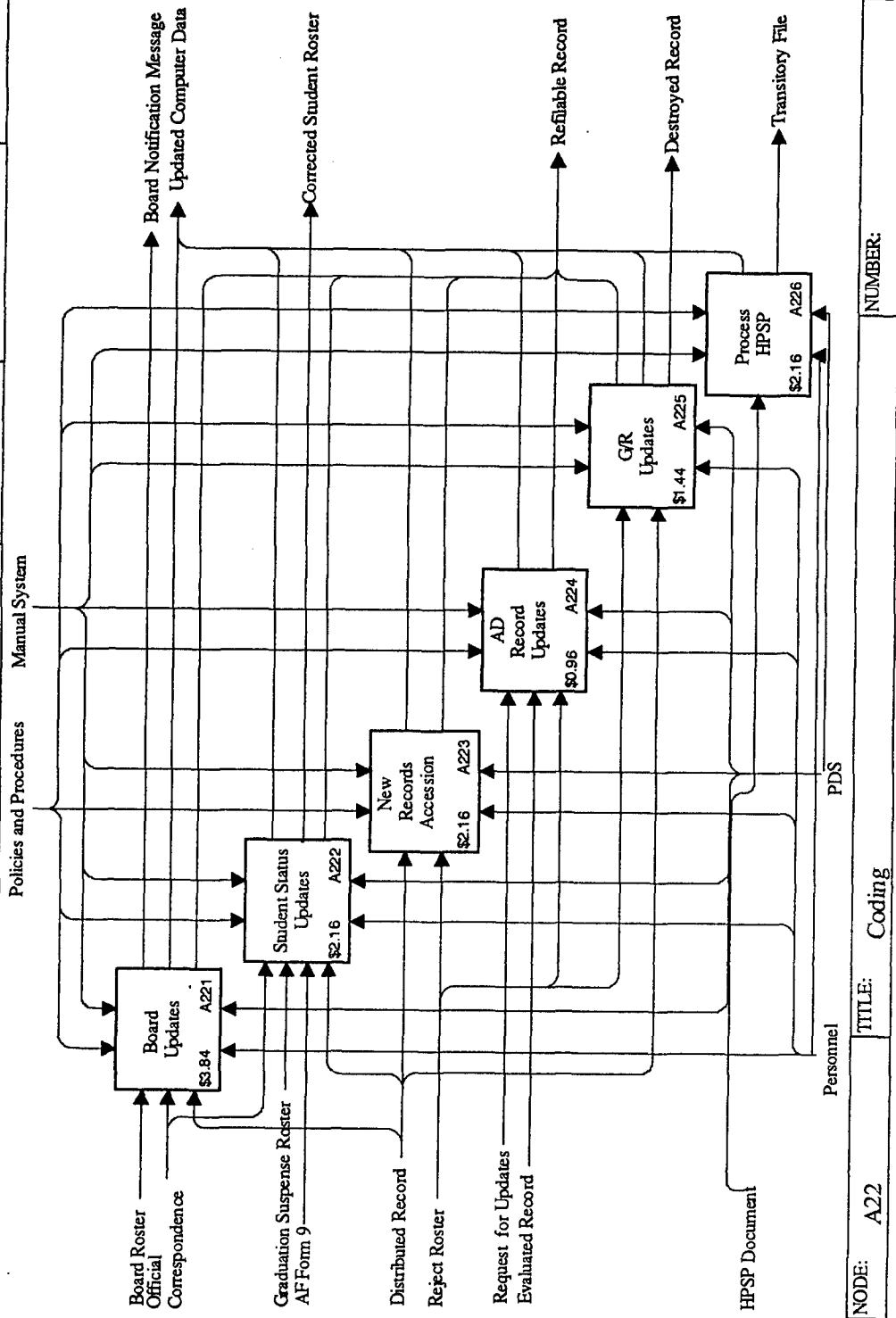

NODE: A22	TITLE: Coding	NUMBER:
-----------	---------------	---------

USED AT:	AUTHOR: Capt Hutchinson/Capt McCoy	DATE: 26 September 1994	WORKING	READER	DATE	CONTEXT:
PROJECT: AFIT/RRA	REV:		DRAFT			
NOTES: 1 2 3 4 5 6 7 8 9			RECOMMENDED			
			X PUBLICATION			

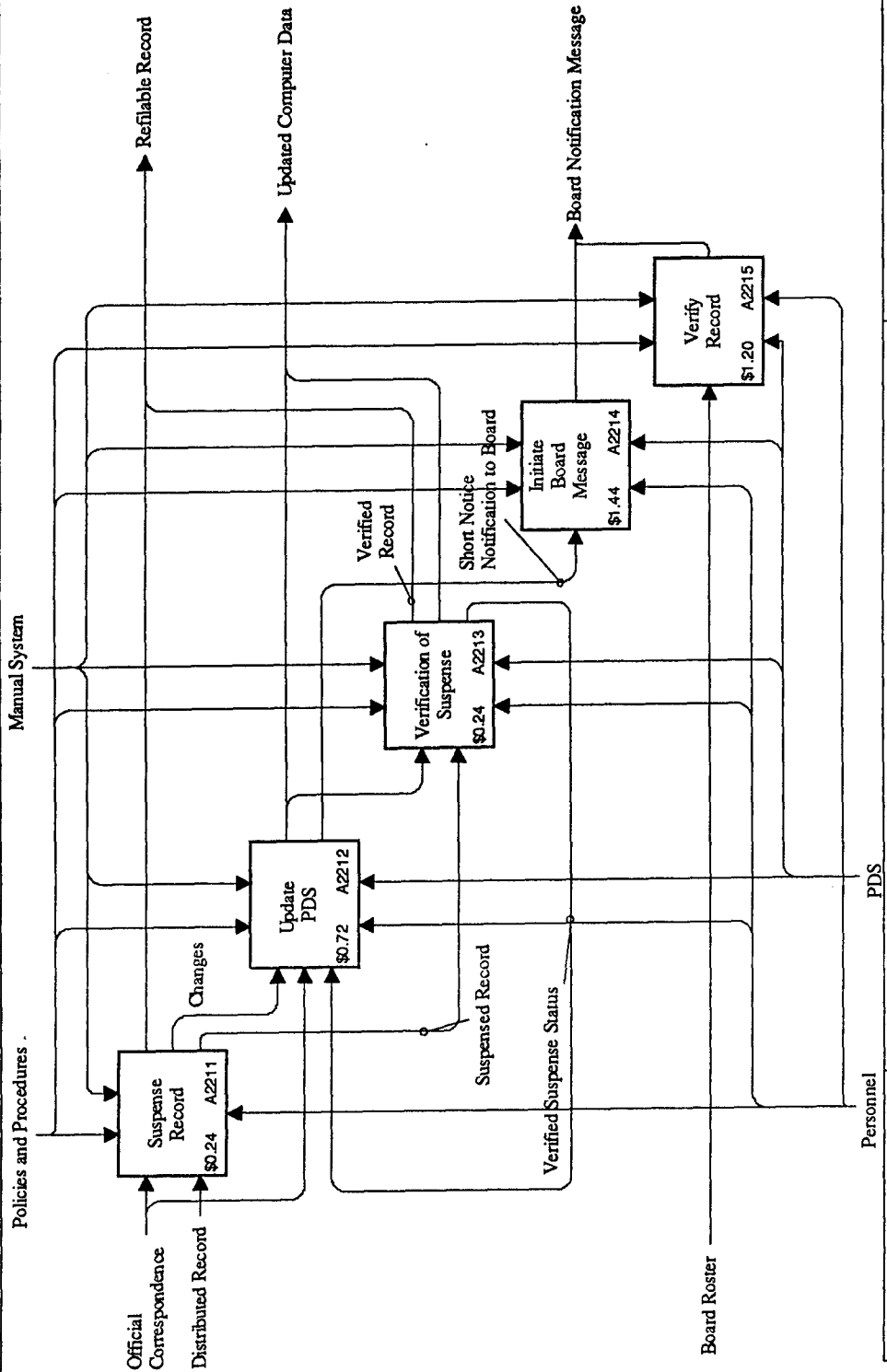

NODE: A221	TITLE: Board Updates	NUMBER:
------------	----------------------	---------

USED AT:	AUTHOR: Capt Hutchinson/Capt McCoy	DATE: 26 September 1994	READER	DATE	CONTEXT:
PROJECT: AFTI/RRR		REV:			
NOTES: 1 2 3 4 5 6 7 8 9			WORKING		
			DRAFT		
			RECOMMENDED		
			PUBLICATION		

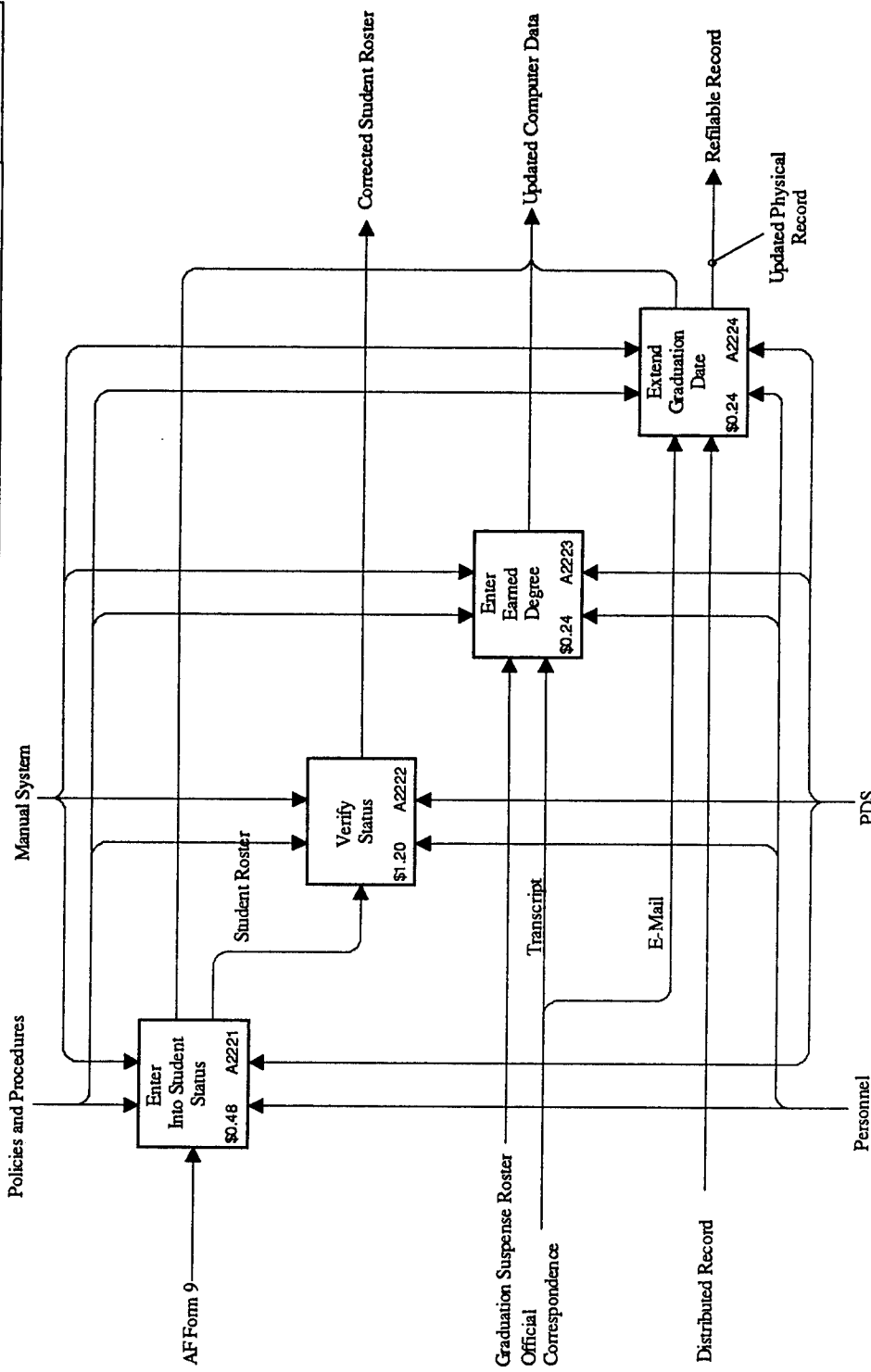

NODE: A222	TITLE: Student Status Updates	NUMBER:
------------	-------------------------------	---------

USED AT:	AUTHOR: Capt Hutchinson/Capt McCoy PROJECT: AFIT/RA	DATE: 26 September 1994 REV:	WORKING	READER	DATE	CONTEXT:
	NOTES: 1 2 3 4 5 6 7 8 9		DRAFT			<input type="checkbox"/>
			RECOMMENDED			<input type="checkbox"/>
			PUBLICATION			<input type="checkbox"/>
			X			<input type="checkbox"/>

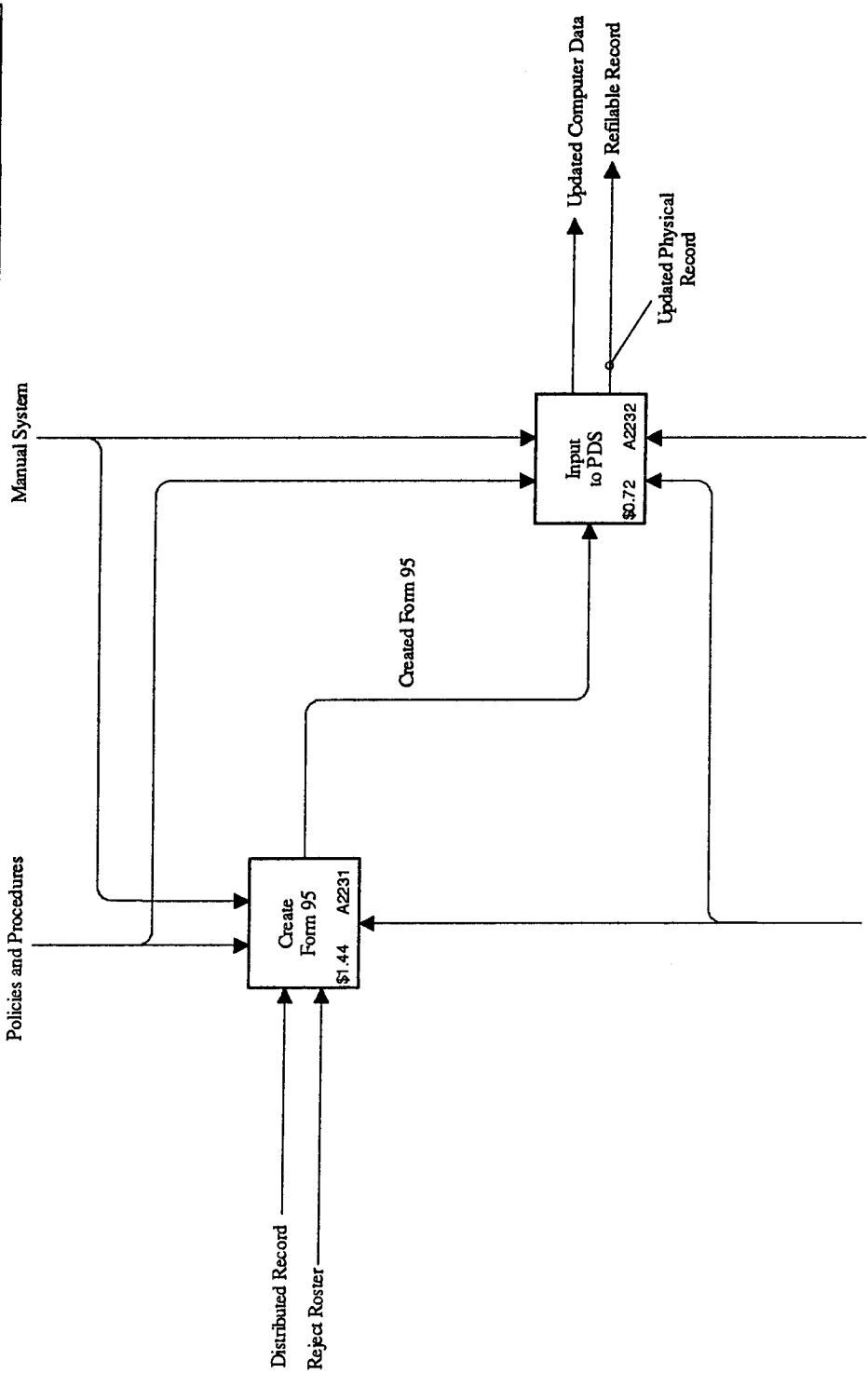

NODE: A223	TITLE: New Records Accession	NUMBER:
------------	------------------------------	---------

USED AT:	AUTHOR: Capt Hutchinson/Capt McCoy PROJECT: AFT/RRR	DATE: 26 September 1994 REV:	WORKING	READER	DATE	CONTEXT:
	NOTES: 1 2 3 4 5 6 7 8 9 1C		DRAFT			<input type="checkbox"/>
			RECOMMENDED			<input type="checkbox"/>
			<input checked="" type="checkbox"/> PUBLICATION			<input type="checkbox"/>

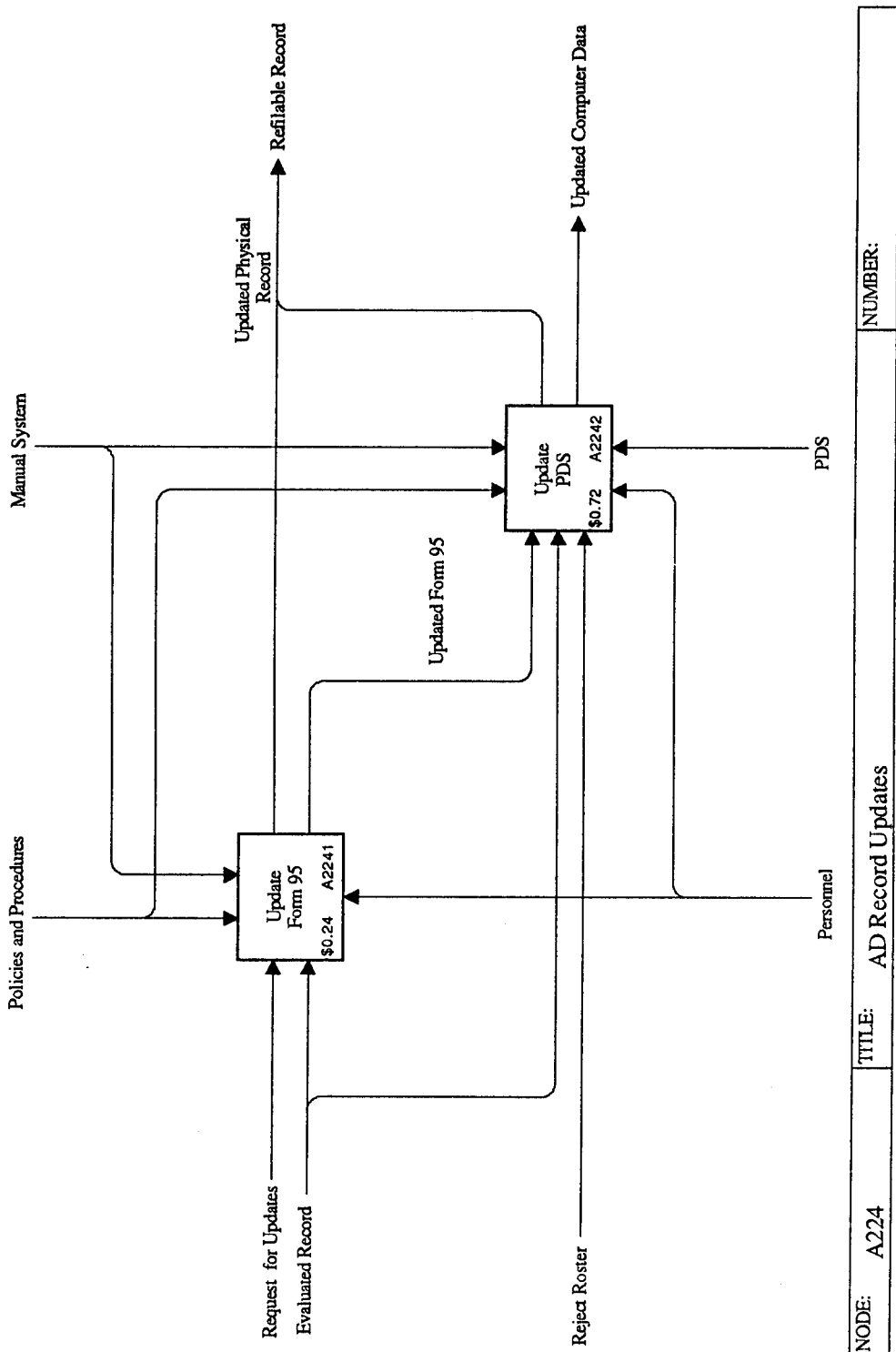

NODE: A224	TITLE: AD Record Updates	NUMBER:
------------	--------------------------	---------

USED AT:	AUTHOR: Capt Hutchinson/Capt McCoy	DATE: 26 September 1994	WORKING	READER	DATE	CONTEXT:
PROJECT: AFIT/RA	REV:		DRAFT			<input type="checkbox"/>
NOTES: 1 2 3 4 5 6 7 8 9			RECOMMENDED			<input type="checkbox"/>
			X PUBLICATION			<input type="checkbox"/>

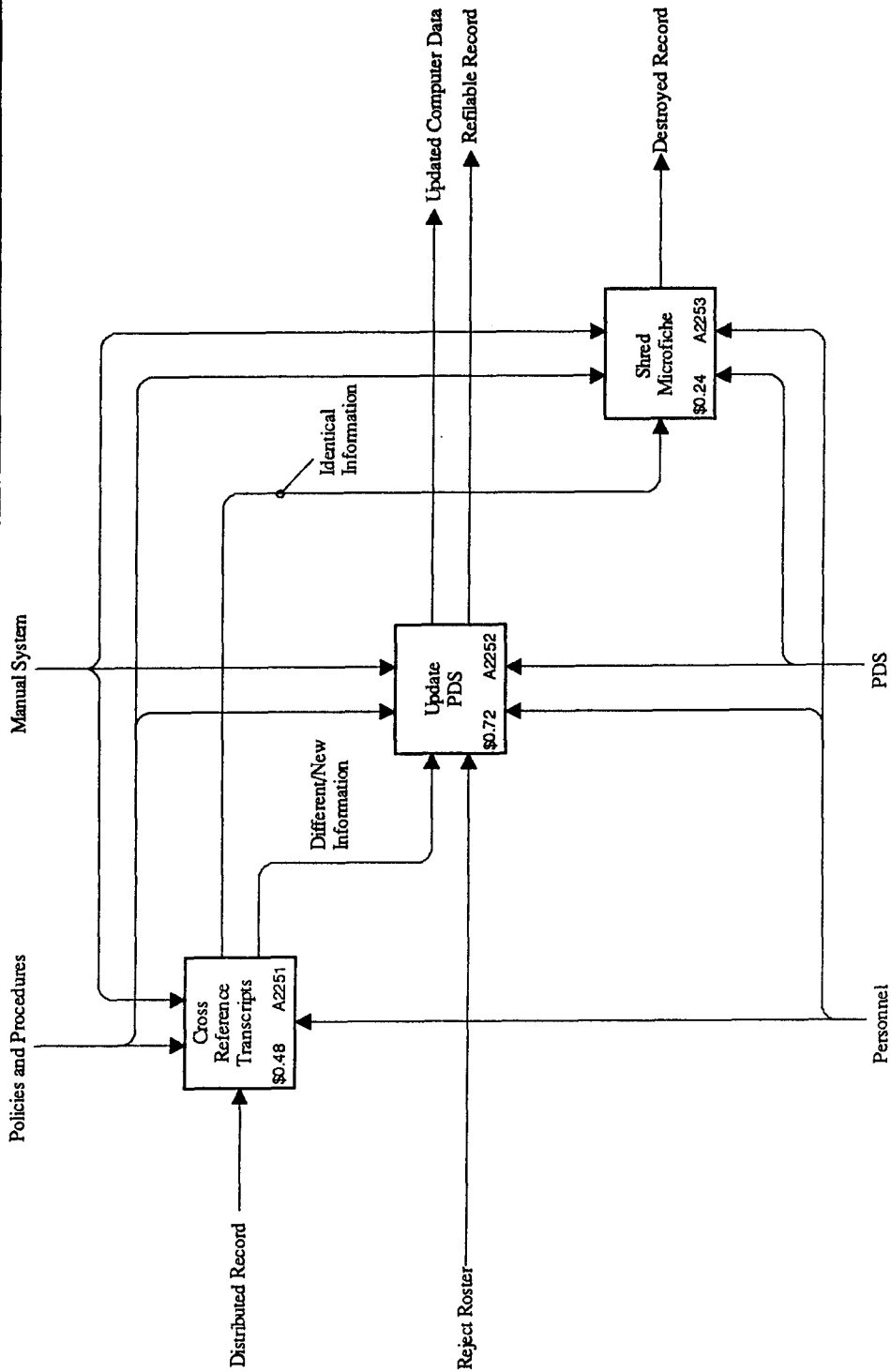

NODE: A225	TITLE: G/R Updates	NUMBER:
------------	--------------------	---------

USED AT:	AUTHOR: Capt Hutchinson/Capt McCoy	DATE: 26 September 1994	WORKING	READER	DATE	CONTEXT:
	PROJECT: AFT/RRR	REV:	DRAFT			<input type="checkbox"/>
	NOTES: 1 2 3 4 5 6 7 8 9		RECOMMENDED			<input type="checkbox"/>
			PUBLICATION			<input checked="" type="checkbox"/>

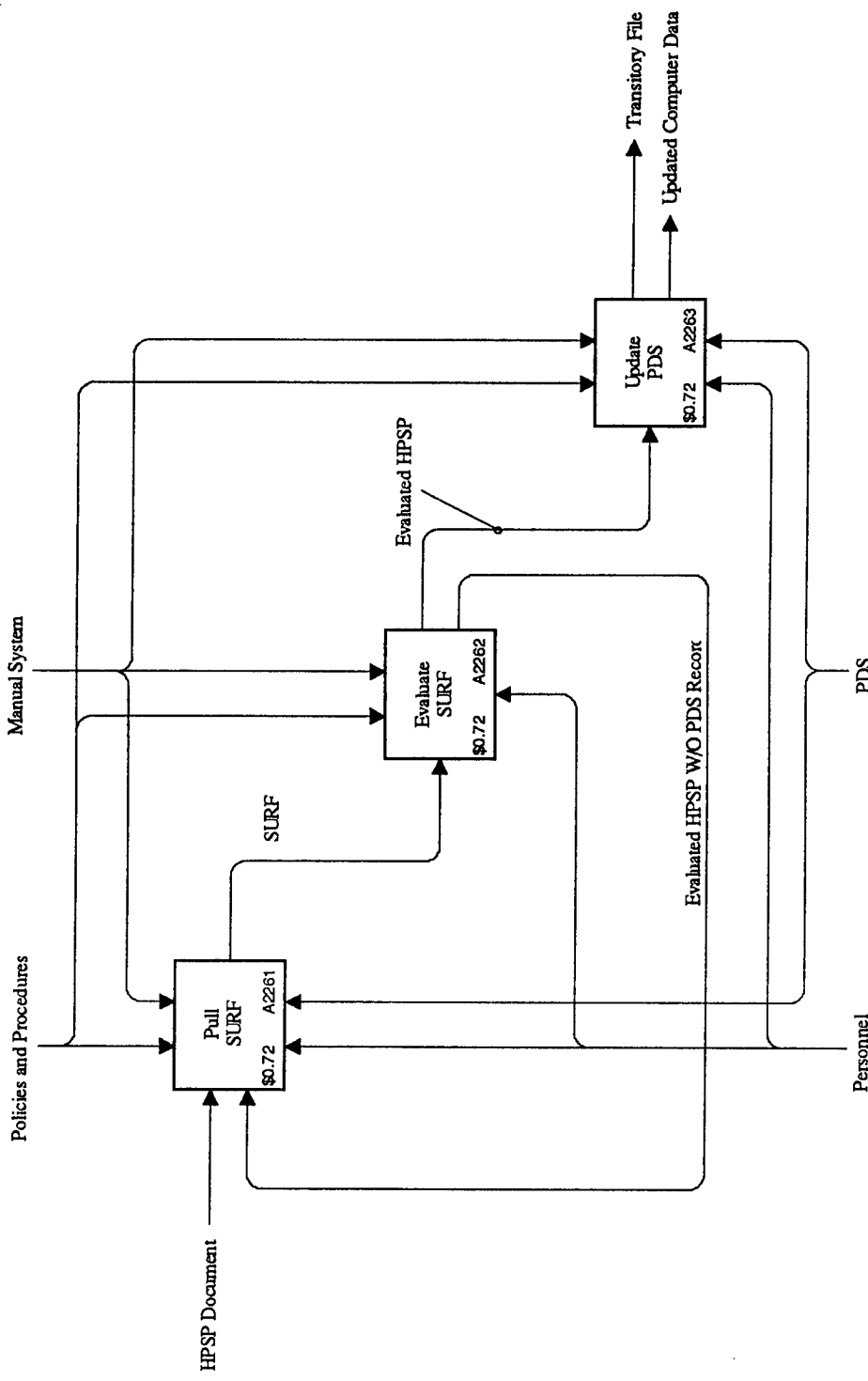

NODE: A226	TITLE: Process HPSP	NUMBER:
------------	---------------------	---------

USED AT:	AUTHOR: Capt Hinchinson/Capt McCoy	DATE: 26 September 1994	WORKING	READER	DATE	CONTEXT:
	PROJECT: AFTI/RRR	REV:	DRAFT			<input type="checkbox"/>
	NOTES: 1 2 3 4 5 6 7 8 9		RECOMMENDEE			<input type="checkbox"/>
			X PUBLICATION			<input checked="" type="checkbox"/>

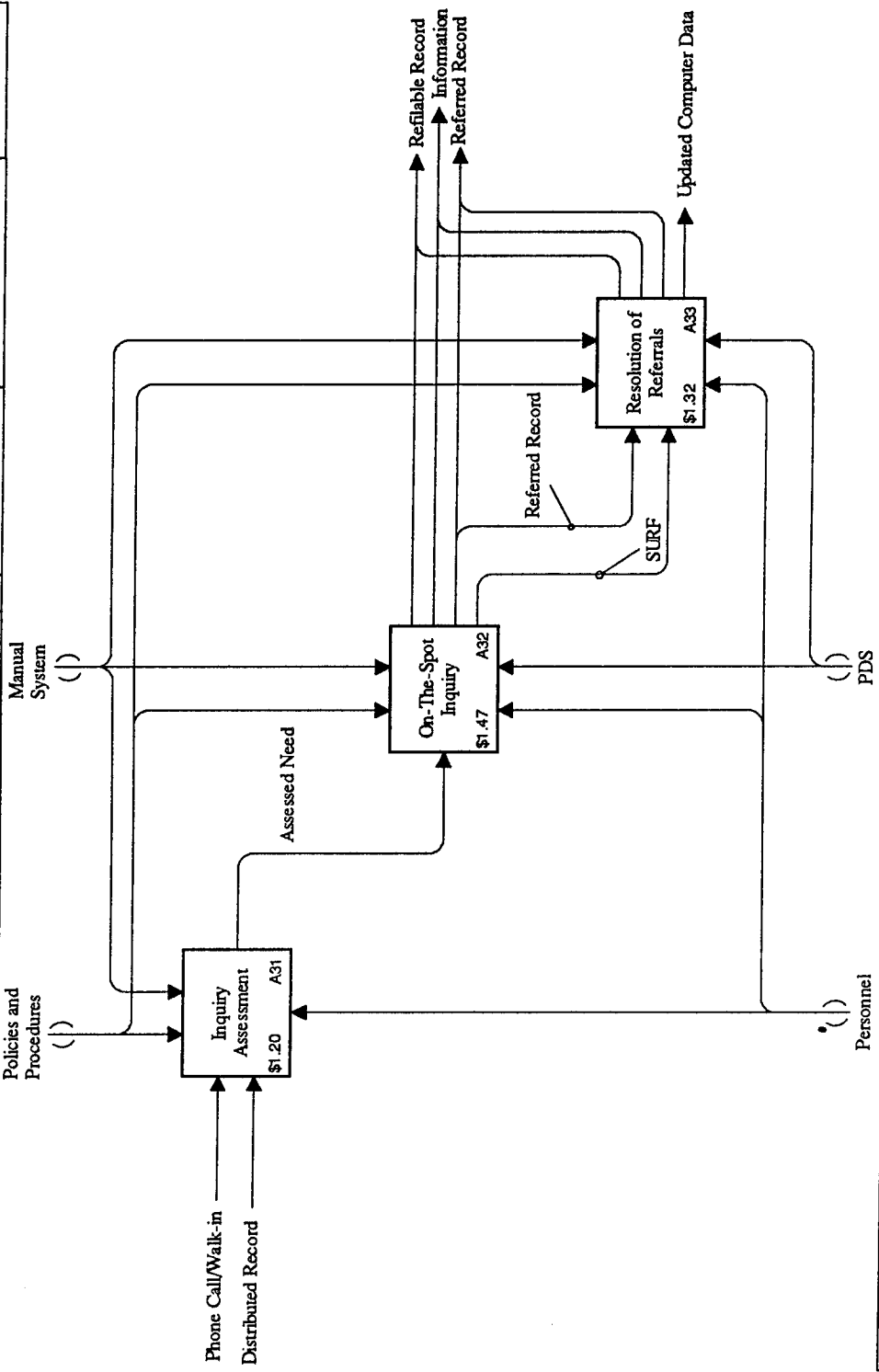

NODE: A3	TITLE: Provide Customer Service	NUMBER:
----------	---------------------------------	---------

USED AT:	AUTHOR: Capt Hutchinson/Capt McCoy	DATE: 26 September 1994	READER	DATE	CONTEXT:
	PROJECT: AFIT/RA	REV:	WORKING		<input type="checkbox"/>
	NOTES: 1 2 3 4 5 6 7 8 9		DRAFT		<input type="checkbox"/>
			RECOMMENDEL		<input checked="" type="checkbox"/>
			PUBLICATION		<input type="checkbox"/>

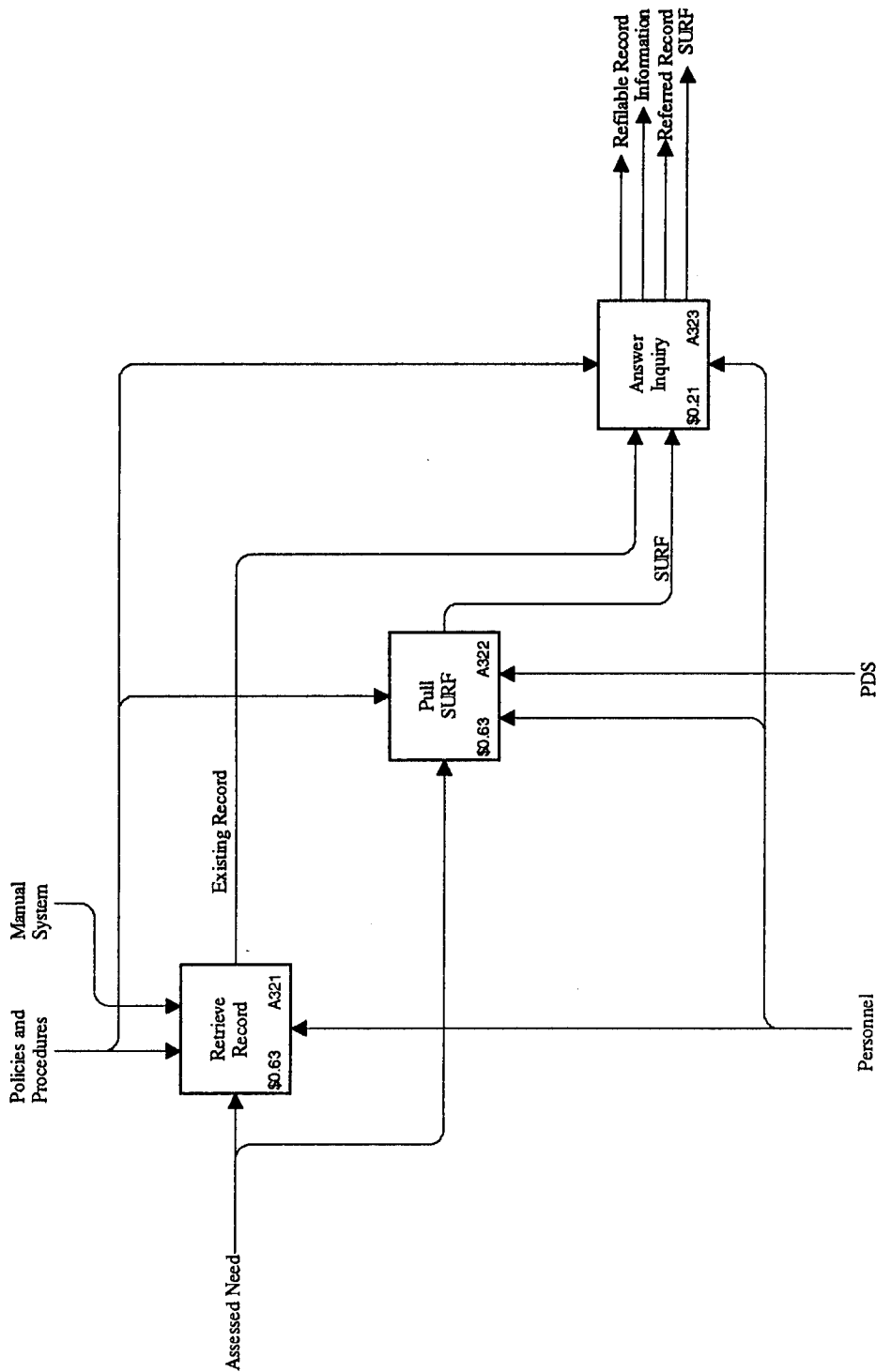

NODE: A32	TITLE: On-The-Spot Inquiry	NUMBER:
-----------	----------------------------	---------

USED AT:	AUTHOR: Capt Hutchinson/Capt McCoy PROJECT: AFTI/RRR	DATE: 26 September 1994 REV:	WORKING	READER	DATE	CONTEXT:
	NOTES: 1 2 3 4 5 6 7 8 9		DRAFT			<input type="checkbox"/>
			RECOMMENDED			<input type="checkbox"/>
			PUBLICATION			<input checked="" type="checkbox"/>

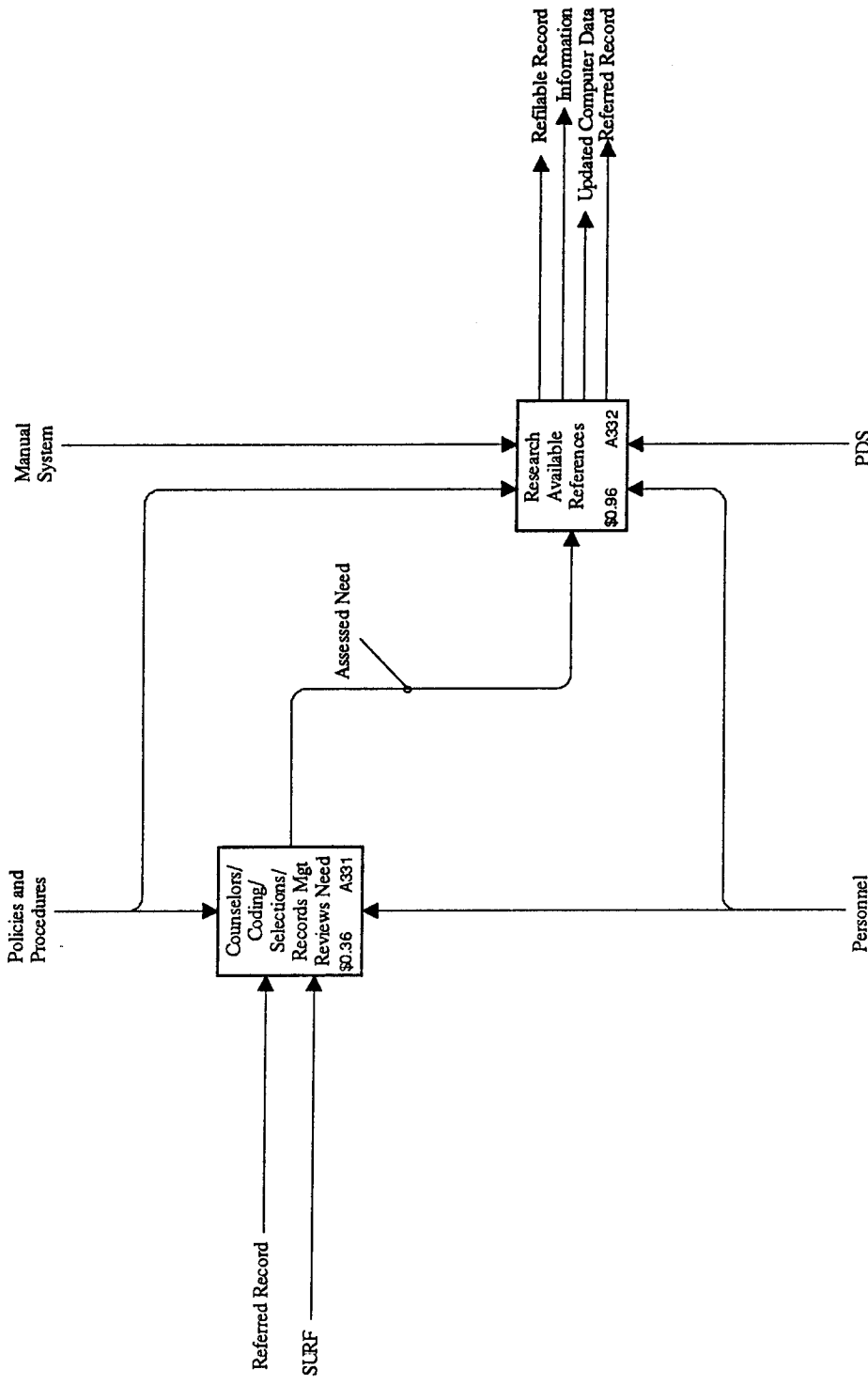

NODE: A33	TITLE: Resolution of Referrals	NUMBER:
-----------	--------------------------------	---------

Appendix B: Flow Charts/Models for Duration

These flowcharts show the duration times associated with each activity to manage an education record. Durations for each lowest-level activity are automatically combined to attain the activity duration for their parent.

RRA Process Active Duty Education-Related Documents

Batch = 50

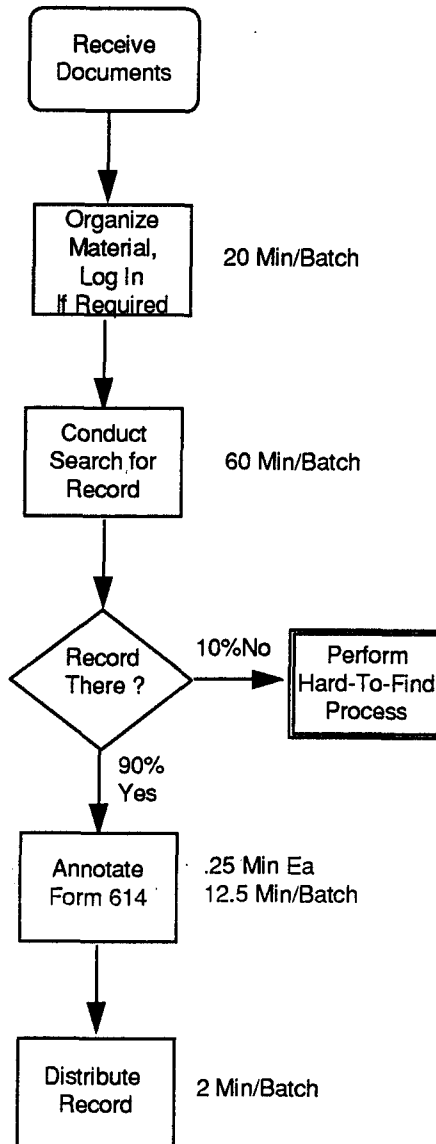

RRA Process Reserve/Guard Education-Related Documents

Batch = 50

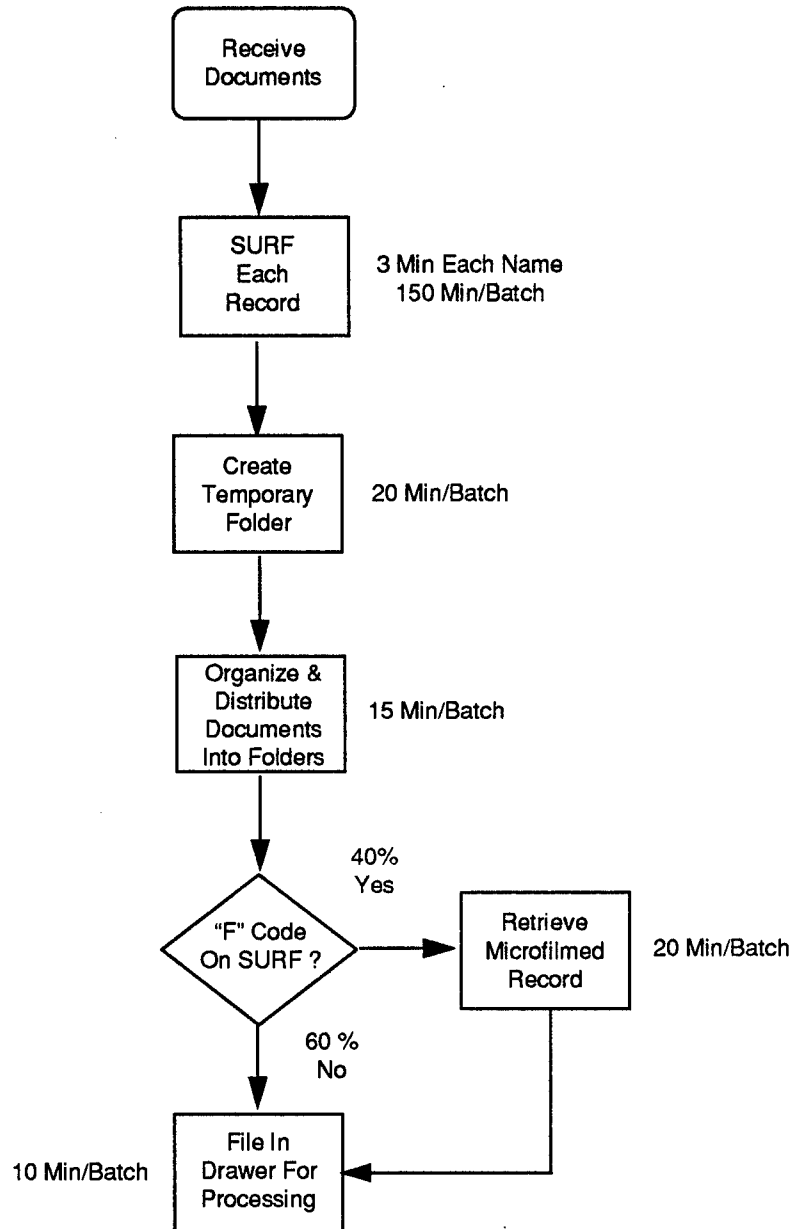

RRA Perform Hard-To-Find Search

10% of Total
Documents Processed

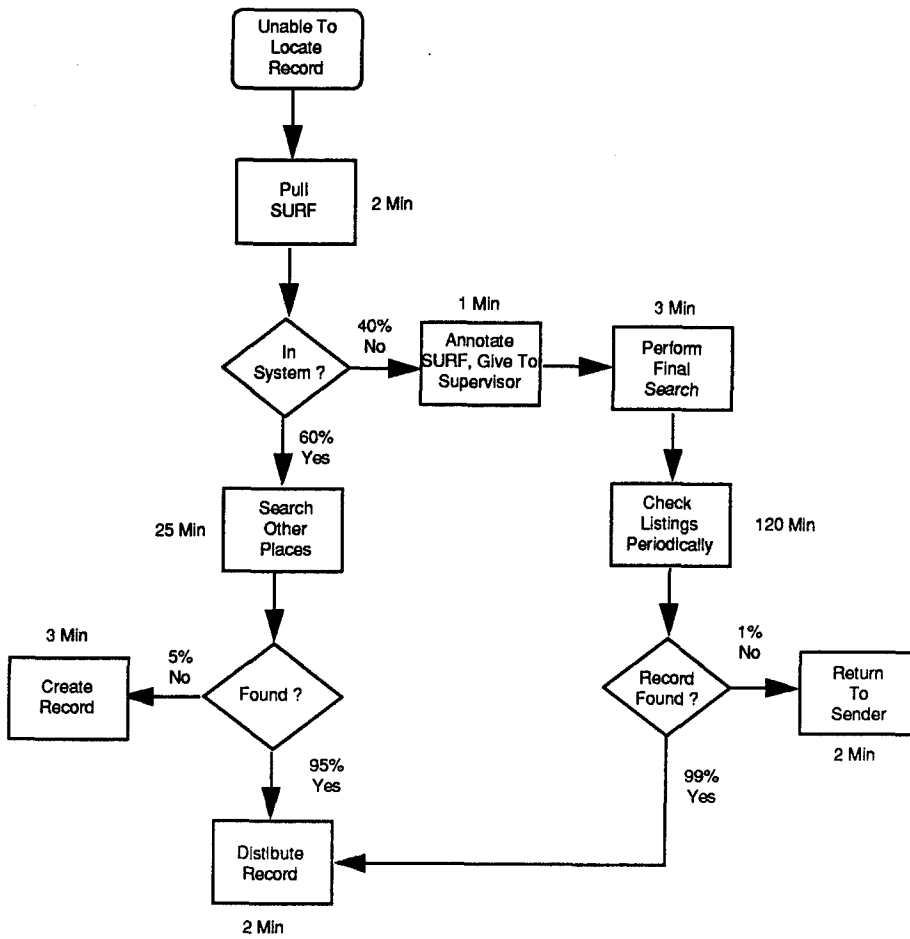

RRA Maintain/Update Permanent Records

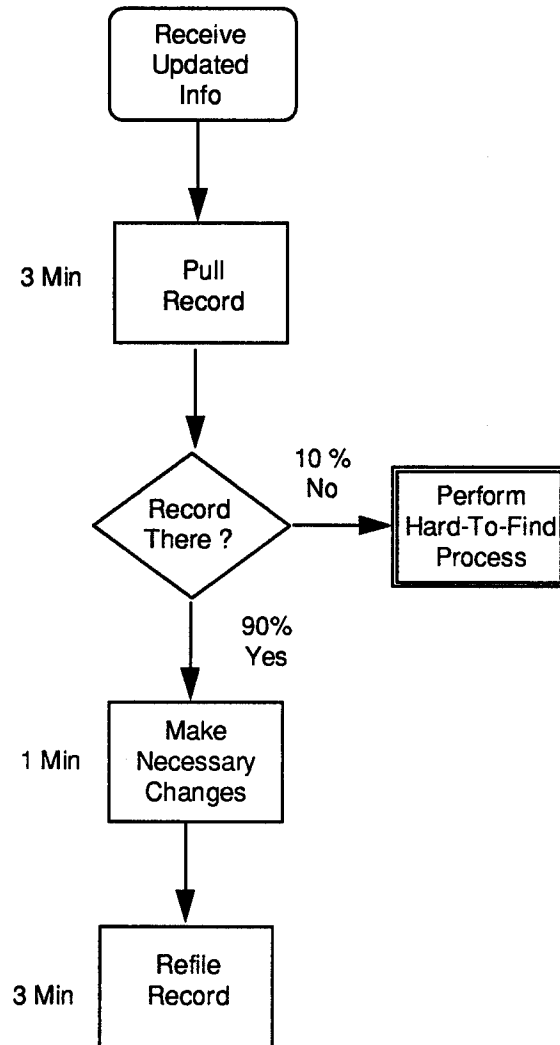

RRA Retrieve Requested Records

Batch = 50

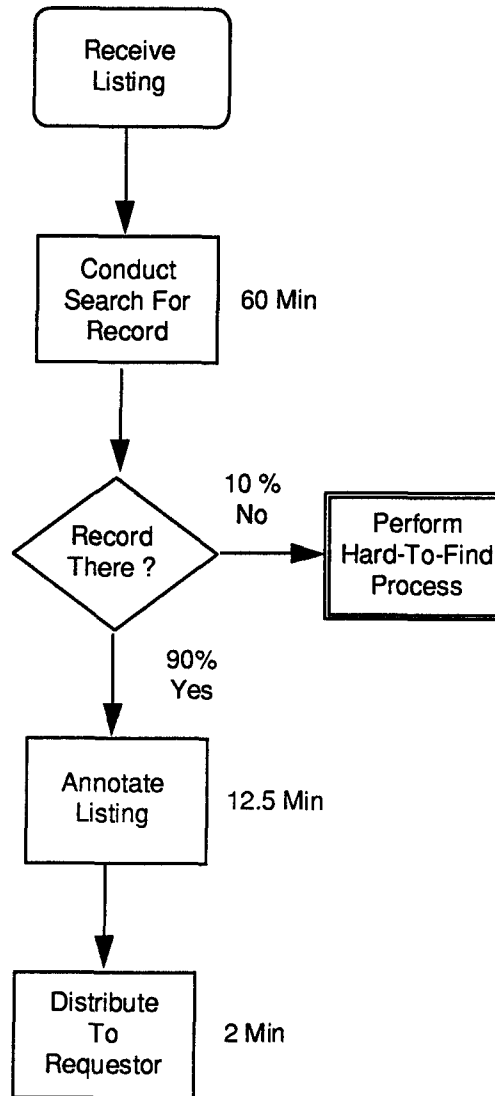

RRA Process Transfer Records

Batch = 50 When Described

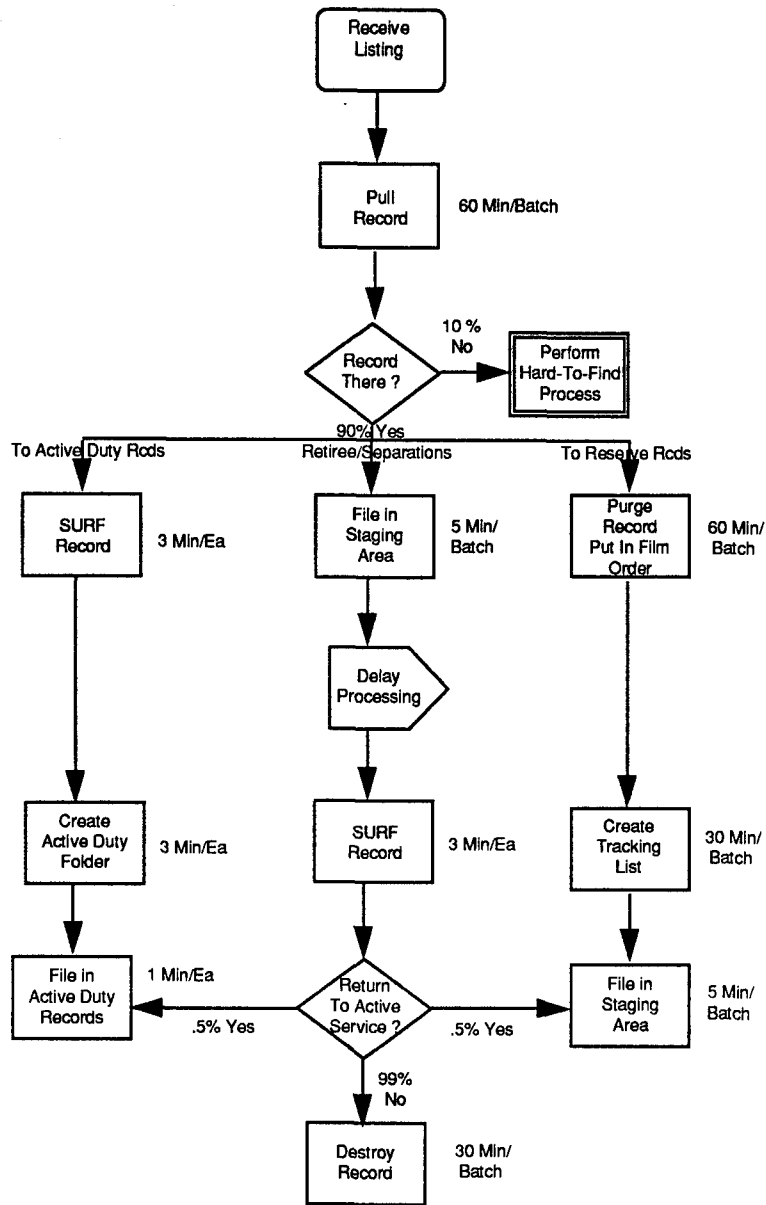

RRA Provide Verbal Info

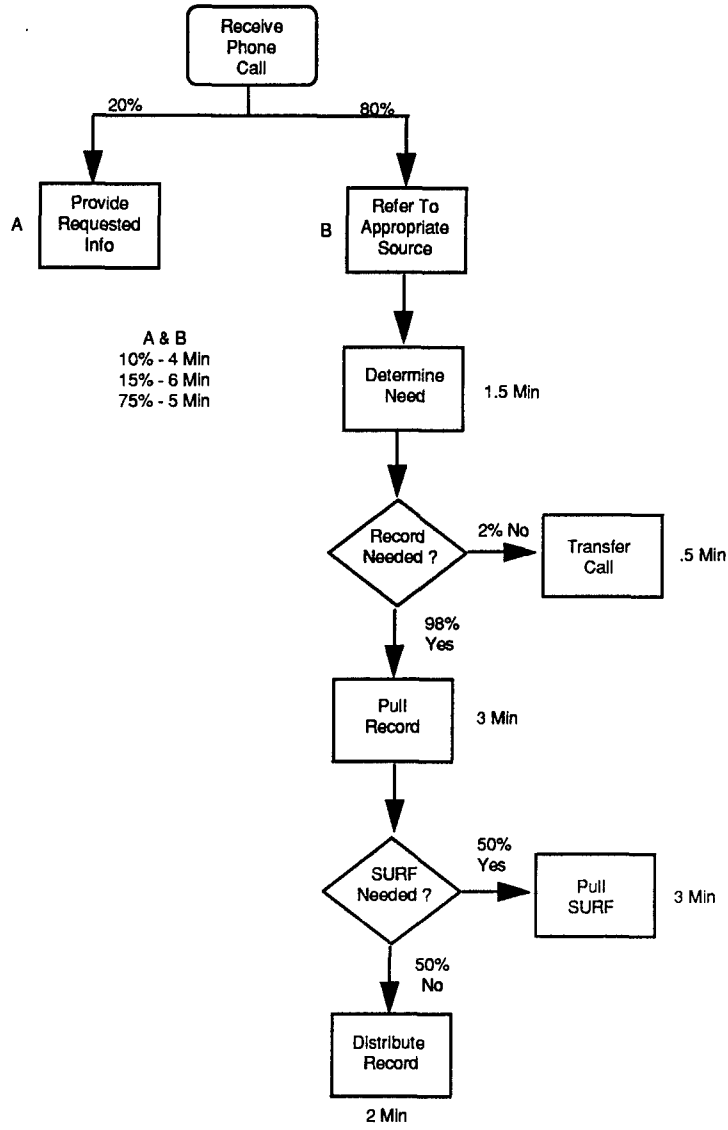

RRA Refile Record

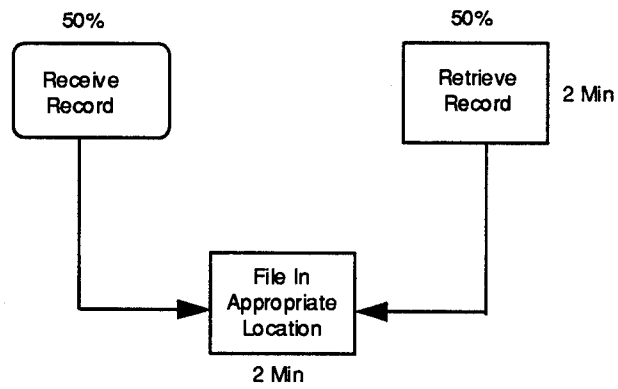

RRA

Perform Annual Purge

80 Hours X 15 People =
1200 Hrs
1/Yr
72,000 Min

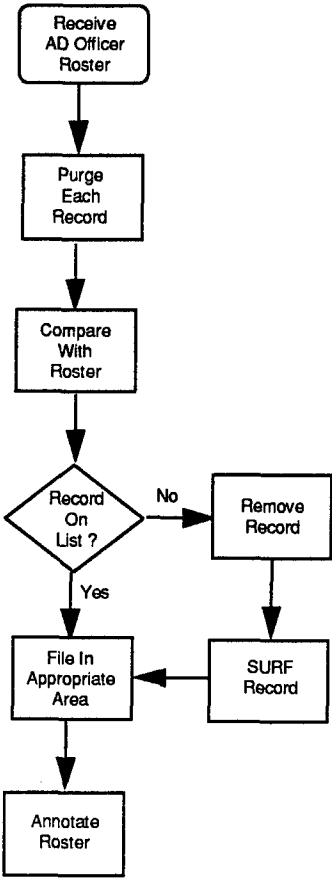

Appendix C: Glossary for "AS-IS" Model

This glossary defines all terms used in the IDEF0 model in Appendix A. All activity and ICOM (inputs, controls, outputs, and mechanisms) names are presented to facilitate communication with individuals wishing to use the previously mentioned IDEF0 models.

AD RECORD UPDATES - The updating of an active duty officer RECORD by CODING.

AD (Active Duty) TO G/R (Guard/Reserve) MICROFICHE - Microfiche that contains data on Air Force Reserve or Air National Guard officers that were previously on active duty.

AF FORM 9 - Air Force form generated by the Civilian Institutes Division that indicates completion of civilian institute-sponsored degrees. Used by CODING to update officer data in the PDS.

ANNOTATED FORM 95 - An Air Force form used by SELECTIONS that reflect AFIT program requirements, current grade point average for officer and memos for record from CODING and COUNSELING SERVICES.

ANSWER INQUIRY - Resolving a CUSTOMER'S ON-THE-SPOT INQUIRY.

ASSESSED NEED - The determined need of a PHONE CALL/WALK-IN customer.

ATLAS LIST - A computer generated report that is initiated both at AFMPC and locally.

BOARD NOTIFICATION MESSAGE - A message prepared by CODING to provide AFMPC officer data used by officer promotion boards.

BOARD ROSTER - A type of ROSTER forwarded from AFMPC for verification of officer data prior to the convening of officer promotion boards.

BOARD UPDATES - The process of providing AFMPC data for officer promotion boards.

BTB (Back to Betty) FOR MAILING - The process of preparing correspondence for mailing by the COUNSELING SERVICES secretary.

BUILD PHYSICAL RECORD - The creation of a "hard" record.

CALCULATE GPA - The conversion of a grade point average to conform to the AFIT standard.

CHANGES - A SUSPENDED RECORD that requires updating in the PDS.

CODING - A child or component activity of the **MAINTAIN RECORDS** activity that updates officer education data in the PDS.

COMPLETED LOG - An **EVALUATION LOG** that is returned to the **COUNSELING SERVICES** secretary after a counselor has evaluate the attached records.

COMPLETED RECORD - A **RECORD** that has been **REVIEWED FOR MISSING DOCUMENTS** by a counselor.

COMPLETED RECORD W/AFIT GPA - A **RECORD** that has been examined and has a GPA officially calculated by a **COUNSELOR** according to guidelines set by Air University and the service academies.

COMPOSE GUIDANCE LETTER - The creation of correspondence (in draft) by a counselor that advises an officer on their eligibility for an AFIT program.

CONTINUE RECORD SEARCH - The process **PULL SURF** indicates that there is an **EXISTING RECORD** therefore the effort to locate the **RECORD** continues until either a **FOUND RECORD** is located or it is determined that **NO RECORD** is present.

CONTROL RECORDS - A child or component activity of the **MANAGE RECORDS** activity. The process which allows for creating, retrieving, refileing, and distributing a record. This process owns the physical substance of a record.

CORRECT RECORD - Could include changing/typing a **LABEL**, combining two records, or updating data in the PDS.

CORRECTED STUDENT ROSTER - A **ROSTER** that has been corrected to reflect a **STUDENT STATUS UPDATE**.

COUNSELING SERVICES - A child or component activity of the **MAINTAIN RECORDS** activity that evaluates officer education records and provides guidance for eligibility for AFIT programs.

COUNSELORS/CODING/SELECTIONS/RECORDS MANAGEMENT REVIEWS NEED - The evaluation of a **CUSTOMER'S** needs by one or more of the named areas.

CREATE/CORRECT RECORDS - A child or component activity of the **CONTROL RECORD** activity. The process which allows for the creation of the initial record; includes initiation of an AF Form 614.

CREATE FORM 95 - The establishment of an Air Force Form 95.

CREATE LOG - The establishment of a list of **DISTRIBUTED RECORDS** created by the **COUNSELING SERVICES** secretary and attached to a group of records given to a counselor for evaluation.

CREATED FORM 95 - An Air Force Form 95 established to condense all educational information on an officer. Used by **CODING** to create a **RECORD** on an active duty officer.

CROSS REFERENCE TRANSCRIPTS - The process of comparing a transcript from an Air National Guard or Air Force Reserve officer against information existing on microfiche.

DESTROYED RECORD - Any **INACTIVE RECORD** that has been shredded after having the appropriate stay in the **STAGING AREA**.

DETERMINE ELIGIBILITY - The evaluation of a **RECORD** by a counselor for eligibility for an **AFIT** program.

DETERMINE NEEDED UPDATES - The review of a **RECORD** by a counselor to determine what required documents are absent or in error.

DIFFERENT/NEW INFORMATION - Information that does not match a record when a **CROSS REFERENCE TRANSCRIPTS** occurs and is therefore forwarded to **UPDATE PDS** by **CODING**.

DISTRIBUTE RECORDS - A child or component activity of the **CONTROL RECORD** activity. The process which allows for the distribution of **EXISTING RECORDS**, **EVALUATED RECORDS**, **NEW ACCESSION RECORDS**, and **UPDATED PHYSICAL RECORDS** to other agencies, both within and outside **AFIT/RR** (includes staging area).

DISTRIBUTED RECORD - A **RECORD** that has been distributed to another agency, either within or outside **AFIT/RR** (includes staging area).

DOCUMENTS - Forms or letters that become part of the **RECORD** or generate actions on the **RECORD**. Includes: AFIT Form 68, AFIT Form 95, official transcript(s), GMAT or GRE test scores, request for evaluation letter(s), and other official correspondence.

ELIGIBLE RECORD - A **RECORD** that has been evaluated by **COUNSELING SERVICES** and the officer has been identified as eligible for an AFIT program.

E-MAIL - A type of **OFFICIAL CORRESPONDENCE**.

ENTER EARNED DEGREE - The process of updating PDS data to reflect completion of an educational degree.

ENTER INTO STUDENT STATUS - The process of converting PDS data to reflect that an officer has become an AFIT student.

ESTABLISH PHYSICAL RECORD - The process which allows for building the physical file and placing any appropriate **DOCUMENT(s)** in side.

EVALUATE SURF - The review of a **SURF** for a **HPSP** student.

EVALUATED HPSP - An **HPSP** student who has data in PDS.

EVALUATED HPSP W/O PDS RECORD - An **HPSP** student who does not have data in PDS.

EVALUATED RECORD - A **RECORD** that has gone through the **MAINTAIN RECORDS** process and whose status is current.

EVALUATION LOG - A list of **DISTRIBUTED RECORDS** created by the **COUNSELING SERVICES** secretary and attached to a group of records given to a counselor for evaluation.

EXAMINE RECORD - An on-the-spot evaluation of an officer's **RECORD** by a counselor in response to a **SCREENED CALL**.

EXISTING RECORD - A **RECORD** that has already been established and which exists in the record repository or has been distributed to another agency. Could be a: status check record; active to guard/reserve record, in microfiche form; guard/reserve to active duty record; transcript update record; or name/social

security number change record. A RECORD that has been retrieved or created and is officially an EXISTING RECORD.

EXTEND GRADUATION DATE - The process of updating a PHYSICAL RECORD and COMPUTER DATA to reflect an extension of a student's graduation date.

EXTRANEIOUS DOCUMENT - Any document that can not or should not be placed in an EXISTING RECORD or can not or should not cause a NEW ACCESSION RECORD to be established. DOCUMENTS that are incomplete/unacceptable or that cannot be matched to an EXISTING RECORD.

F-CODE - Yes or No/present or not present. The presence of an F-CODE helps to determine if there is an EXISTING RECORD on an officer.

FAX - Information transmitted by facsimile to the SELECTIONS section.

FILE LOGS - The process of filing COMPLETED LOGS.

FILED LOGS - A file maintained by COUNSELING SERVICES to store COMPLETED LOGS.

FOUND RECORD - Any RECORD that could be located upon the initial examination of the files in the system.

G/R (Guard/Reserve) TO AD (Active Duty) RECORD - An EXISTING RECORD that requires correction due to the officer's change to Active Duty status from Air National Guard or Air Force Reserve status.

G/R UPDATES - The updating of an Air National Guard or Air Force Reserve officer RECORD by CODING.

GRADUATION SUSPENSE ROSTER - A type of ROSTER that identifies officers pending graduation from an AFIT program.

HPSP DOCUMENT- Health Professional Scholarship Program document used by CODING to place an officer in student status.

IDENTICAL INFORMATION - Information that matches a record completely when a CROSS REFERENCE TRANSCRIPTS occurs and is therefore forwarded to SHRED MICROFICHE by CODING.

INACTIVE RECORD - A RECORD that is no longer active due to retirement, separation or death.

INELIGIBLE RECORD - A RECORD that has been evaluated by COUNSELING SERVICES and the officer has been identified as ineligible for an AFIT program.

INFORMATION - Responses (written or oral) to inquiries.

INITIATE BOARD MESSAGE - The process of creating a BOARD NOTIFICATION MESSAGE in response to a SHORT NOTICE NOTIFICATION TO BOARD.

INPUT TO PDS - The process of entering the information on a CREATED FORM 95 into the PDS.

INQUIRY ASSESSMENT - The determination of a PHONE CALL/WALK-IN CUSTOMER'S needs.

LETTER OF GUIDANCE - Correspondence generated by COUNSELING SERVICES as a result of DETERMINE ELIGIBILITY.

LOG ANNOTATION - The updating of the record log maintained by a counselor. Used to help track DISTRIBUTED RECORDS that have been sent to COUNSELING SERVICES.

MAILED LETTER - Outgoing correspondence.

MAINTAIN RECORDS - A child or component activity of the MANAGE RECORDS activity. This process allows for the update, purging and evaluation of records and the preparation of microfiche. This process owns the "status" of the record.

MANAGE EDUCATION RECORDS - The parent activity which decomposes into the CONTROL RECORDS, MAINTAIN RECORDS, and PROVIDE CUSTOMER SERVICE child activities. This project will only focus on one of the child activities, CONTROL RECORDS.

MANUAL SYSTEM - The present system of manually creating, retrieving, and refilling records.

MODIFICATION RECOMMENDATION - A TYPED LETTER that is returned to a counselor by the Chief of COUNSELING SERVICES for modification. A

MODIFICATION RECOMMENDATION will cause a **RETYPING REQUEST** after the modification is made.

N/A (New Accession) TRANSCRIPT - A transcript received on newly commissioned officers.

NAME/SSN CHANGE RECORD - An **EXISTING RECORD** that requires correction due to a change or error in the officer's name or social security number.

NEW ACCESSION RECORD - An output of the **CREATE/CORRECT RECORD** process that was initiated by an **UNATTACHED DOCUMENT**.

NEW RECORDS ACCESSION - The updating of the **PDS** and **RECORD** by **CODING** of a newly commissioned officer.

NO RECORD - A determination that no record exists after a the **PULL SURF, CONTINUE RECORD SEARCH** process has been completed. File is then forwarded to **BUILD PHYSICAL RECORD**.

OFFICIAL CORRESPONDENCE - A general term that includes **PROFESSIONAL DIPLOMA, N/A (NEW ACCESSION) TRANSCRIPT, TEST SCORE,** and **UNATTACHED DOCUMENT**.

ON-THE-SPOT INQUIRY - The immediate resolution of a **PHONE CALL/WALK-IN CUSTOMER'S** need.

PDS - The Personnel Data System (PDS). **AFIT/RR** is the sole update source for all officer academic data in the PDS. The PDS runs on a Honeywell DPS8 computer system under the **GCOS** operating system.

PERSONNEL - The staff of the **RECORDS AND SYSTEMS MANAGEMENT DIVISION**. Includes the Chief, a Superintendent, Office Automation Clerks (2), Administrative Specialists (2), Education Technicians (4) and a Personnel Systems Manager.

PHONE CALL/WALK-IN - An inquiry from a **CUSTOMER** that is either initiated by telephone or by the **CUSTOMER** in person.

PLACE IN "IN BASKET" - Placing files in drawers in a centrally located filing cabinet that are used to "hold" files until responsible individual(s) pick them up.

PLACE IN STAGING AREA - Placing files in the storage area for inactive files.

POLICIES AND PROCEDURES - The regulations or manuals which provide guidance for the **RECORDS AND SYSTEMS MANAGEMENT DIVISION**. Includes: AFIT/RRA Operating Instruction, AFM 30-130 Volume 1, AFR 35-25, AFR 36-1, AFCAT 36-2223, AURP 53-2 Volume 17 Number 1, and AFR 700-20 Volume I.

PREPARE OUTGOING MAIL - The final preparation by the **COUNSELING SERVICES** secretary of correspondence generated by a counselor.

PROCESS HPSPs - The updating of the PDS to place an officer who has received a Health Professional Scholarship into student status.

PROFESSIONAL DIPLOMA - A medical, legal, or clerical diploma that is categorized as part of **OFFICIAL CORRESPONDENCE**.

PROVIDE CUSTOMER SERVICE - The process that interfaces directly with the customer to attempt to provide on-the-spot information.

PULL SURF - The retrieval of data in the PDS on a specific officer.

RECORD - The final compilation of **DOCUMENTS** and data in the **COMPUTER SYSTEM** on a subject officer.

RECORD EVALUATION - The evaluation of a **RECORD** by a counselor to determine an officer's eligibility for an AFIT program.

RECORD SCREENING - The review of records used to assigned workload to counselors and compile the **EVALUATION LOG**.

RECORD WITH AFIT GPA - A **RECORD** that has had the grade point average converted to the AFIT standard.

RECORDS AND SYSTEMS MANAGEMENT DIVISION - The division of the AFIT Registrar's organization with primary responsibility for the: Officer Educational Transcript Repository (OETR); officer academic updates Air Force wide; and management and maintenance of PDS resources and terminals.

REFERRED RECORD - A **RECORD** that is distributed to another person or department.

REFILABLE RECORD - A RECORD that is ready to be refiled.

REFILE RECORDS - A child or component activity of the CONTROL RECORD activity. A process which allows for the refile of a record once it has been returned to the Administrative Specialists.

REFORMAT INFORMATION - The assembling of EXTRACTED INFORMATION to meet the requirements of an EXTERNAL REQUEST FOR INFO.

REFORMATTED INFORMATION - The assembled EXTRACTED INFORMATION for an EXTERNAL REQUEST FOR INFO.

REJECT ROSTER - A type of ROSTER used by CODING that indicates data input errors.

REQUEST FOR MISSING DOCUMENTS - Correspondence generated by a counselor to notify an officer that evaluation of his/her education record cannot be completed until the officer supplies the requested missing information.

REQUEST FOR UPDATES - A COUNSELOR'S request to CODING to make updates to a record after completing a STATUS CHECK.

RESEARCH AVAILABLE REFERENCES - The consultation of reference materials to answer a CUSTOMER'S ASSESSED NEED.

RESOLUTION OF REFERRALS - The resolution of a CUSTOMER'S needs within the MANAGE EDUCATION RECORDS process.

RETRIEVE RECORDS - A process which allows for retrieving a record when needed by the Administrative Specialist for processing, inquiries or distribution; includes an annotation of the AF Form 614.

RETYPED LETTER - A TYPED LETTER that is retyped due to errors.

RETYPING REQUEST - A TYPED LETTER that is sent back to the COUNSELING SERVICES secretary due to errors.

REVIEW BY COUNSELOR - The review of a TYPED LETTER by the counselor who originated the letter.

REVIEW BY SECOND COUNSELOR - The review of a **REVIEWED LETTER** by another counselor.

REVIEW/APPROVAL/SIGNATURE BY CHIEF - The process of reviewing/approving/signing a correct **TYPED LETTER** by the Chief of **COUNSELING SERVICES**.

REVIEW FOR MISSING DOCUMENTS - The review of a **RECORD** by a counselor to determine if any required documents are absent.

REVIEW RECORD - The cursory screening of a **DISTRIBUTED RECORD** by the **COUNSELING SERVICES** secretary for distribution to a counselor.

REVIEWED LETTER - A reviewed **TYPED LETTER**.

REVIEWED RECORD - A **DISTRIBUTED RECORD** that has been reviewed by the **COUNSELING SERVICES** secretary for distribution to a counselor.

ROSTER- ATLAS LISTS and other computer generated reports that are initiated both at AFMPC and locally. Includes: Transaction Rosters (TRs); purge rosters; name change rosters; quality check rosters; Health Professions Scholarship Program Roster; reject/error rosters.

SCREEN CALLS - The assessment by the **COUNSELING SERVICES** secretary of an incoming **PHONE CALL**.

SCREEN CORRESPONDENCE - The process of reviewing incoming correspondence to **COUNSELING SERVICES** by the secretary for distribution to the proper person.

SCREENED CALL - A **PHONE CALL** that is routed to **COUNSELING SERVICES** or a department outside of those under the process **MANAGE EDUCATION RECORDS**.

SCREENED CORRESPONDENCE - Incoming correspondence to **COUNSELING SERVICES** that has been screened by the secretary for distribution to the proper person.

SCREENED RECORD - A **DISTRIBUTED RECORD** that has been screened by the **COUNSELING SERVICES** secretary for distribution to a counselor.

SELECTIONS - A child or component activity of the **MAINTAIN RECORDS** activity that chooses officers for **AFIT** programs.

SHORT-NOTICE NOTIFICATION TO BOARD - A requirement from **AFMPC** for immediate information on an officer meeting a promotion board.

SHRED MICROFICHE - The destruction of a microfiche record.

SIGNED LETTER - Correspondence that is ready for mailing.

SOURCE DOCUMENT - Air Force Form 517 used by the **SELECTIONS** section for determining officer eligibility for an **AFIT** program.

STATUS CHECK - An on-the-spot evaluation of an officer's **RECORD** by a counselor in response to a **SCREENED CALL**.

STATUS CHECK RECORD - An **EXISTING RECORD** that requires a change in the status of the officer.

STORED RECORD - A **RECORD** that is refiled in the record file.

STUDENT ROSTER - A roster that lists officers recently entered into student status.

STUDENT STATUS UPDATES - The updating of information in the **PDS** to indicate that an officer is enrolled in an **AFIT** program.

SURF (Search Under Record File) - Computer data maintained on an officer.

SUSPENSE RECORD - The flagging of a **RECORD** of an officer who will be meeting a promotion board and the **RECORD** is missing certain **DOCUMENTS**.

SUSPENSED RECORD - A **RECORD** that has been suspended for 45 days because of missing **DOCUMENTS**.

TEST SCORE - Forwarded **GRE** or **GMAT** test results.

TRANSCRIPT - A type of **OFFICIAL CORRESPONDENCE**.

TRANSCRIPT UPDATE RECORD - An **EXISTING RECORD** that requires correction due to the completion of additional education credit.

TRANSITORY FILE - A file that contains temporary documents or correspondence.

TWICE REVIEWED LETTER - A **TYPED LETTER** that has been reviewed by the author and a second counselor.

TYPE LETTER - The preparation of correspondence by the **COUNSELING SERVICES** secretary.

TYPED LETTER - Preparation correspondence by the **COUNSELING SERVICES** secretary.

UNATTACHED DOCUMENT - Any existing or new professional diploma, new accession transcript, test scores, or official correspondence, etc. that has been examined by **PERSONNEL** and initiates the **CREATE/CORRECT RECORDS** process.

UNAVAILABLE/INCORRECT INFORMATION - Information or documents that are not present or incorrect in an officers **RECORD**.

UPDATE DATA IN PDS - Personal data is altered in the **PERSONNEL DATA SYSTEM**.

UPDATE FORM 95 - The addition of education information on an Air Force Form 95.

UPDATE LOG - The process of annotating evaluated **RECORDS** on the distributed **EVALUATION LOG**.

UPDATE PDS - The process of changing data in the **PDS**.

UPDATED COMPUTER DATA - Corrections, changes, and/or updates to a **RECORD** that are entered in to the **PDS** and used by outside organizations.

UPDATED FORM 95 - A amended Air Force Form 95.

UPDATED PHYSICAL RECORD - Includes unofficial records, which are valid for 45 days or until the individual(s) sends new document(s).

VERIFICATION OF SUSPENSE - The review of a **SUSPENDED RECORD** after 45 days to determine if the officer has provided a requested transcript

VERIFIED RECORD - A SUSPENDED RECORD that has received a missing transcript.

VERIFIED SUSPENSE STATUS - Checked status of requested transcript.

VERIFY RECORD - The review of a RECORD by CODING to confirm promotion eligibility information requested by AFMPC.

VERIFY STATUS - The process of confirming information on a STUDENT ROSTER.

Appendix D: IDEF0 "TO-BE" Model

This IDEF model shows the "to-be" model developed by the thesis team and validated by one functional team member.

USED AT:	AUTHOR: Capt Hutchinson/Capt McCoy	DATE: 26 September 1994	WORKING	READER	DATE	CONTEXT:
	PROJECT: AFT/RRR	REV:	DRAFT			
	NOTES: 1 2 3 4 5 6 7 8 9 1C		X RECOMMENDED			
			PUBLICATION			

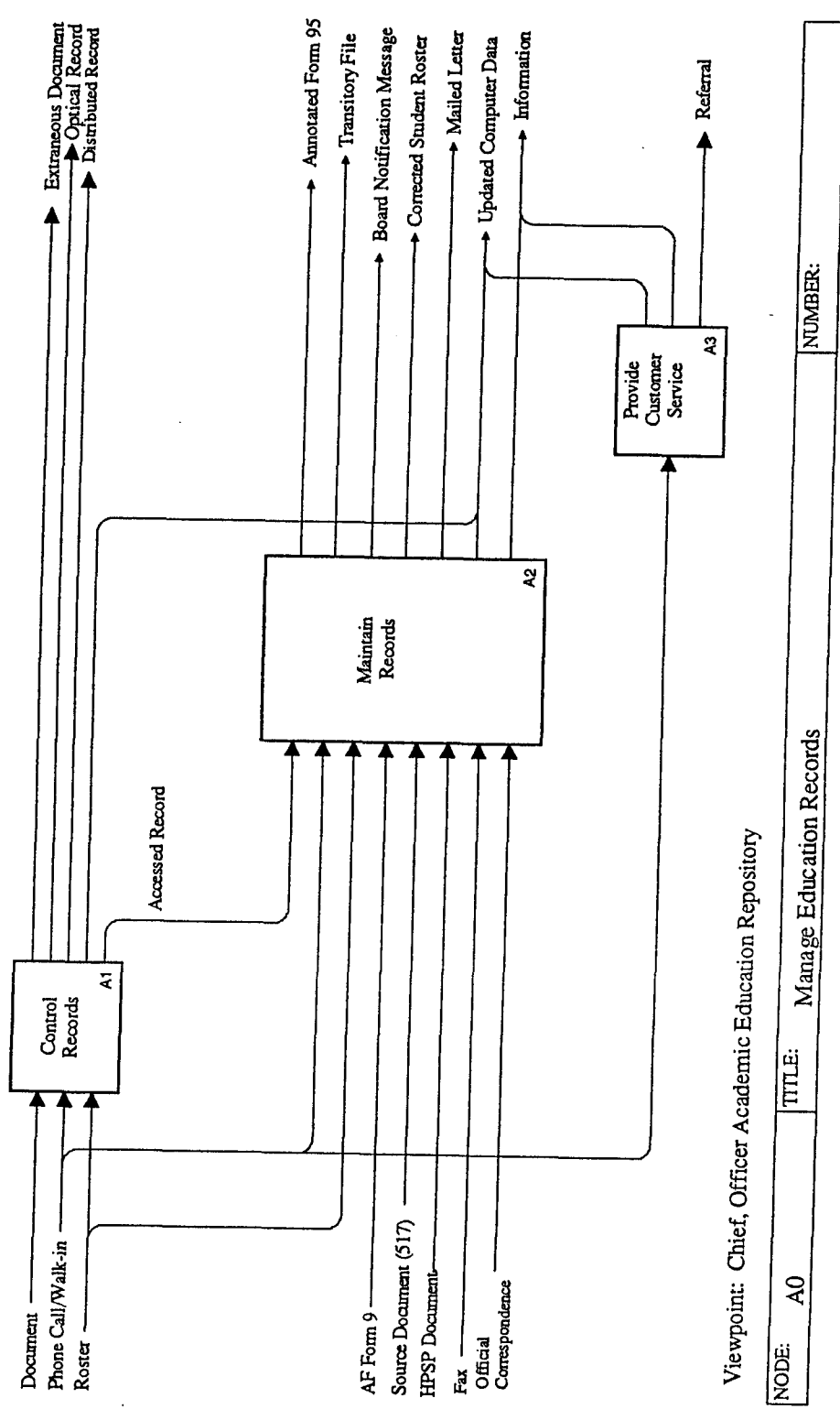

Viewpoint: Chief, Officer Academic Education Repository

NODE: A0	TITLE: Manage Education Records	NUMBER:
----------	---------------------------------	---------

USED AT:	AUTHOR: Capt Hutchinsom/Capt McCoy	DATE: 26 September 1994	WORKING	READER	DATE	CONTEXT:
PROJECT: AFIT/RRR	REV:		DRAFT			<input type="checkbox"/>
NOTES: 1 2 3 4 5 6 7 8 9 10			X RECOMMENDED			<input checked="" type="checkbox"/>
			PUBLICATION			<input type="checkbox"/>

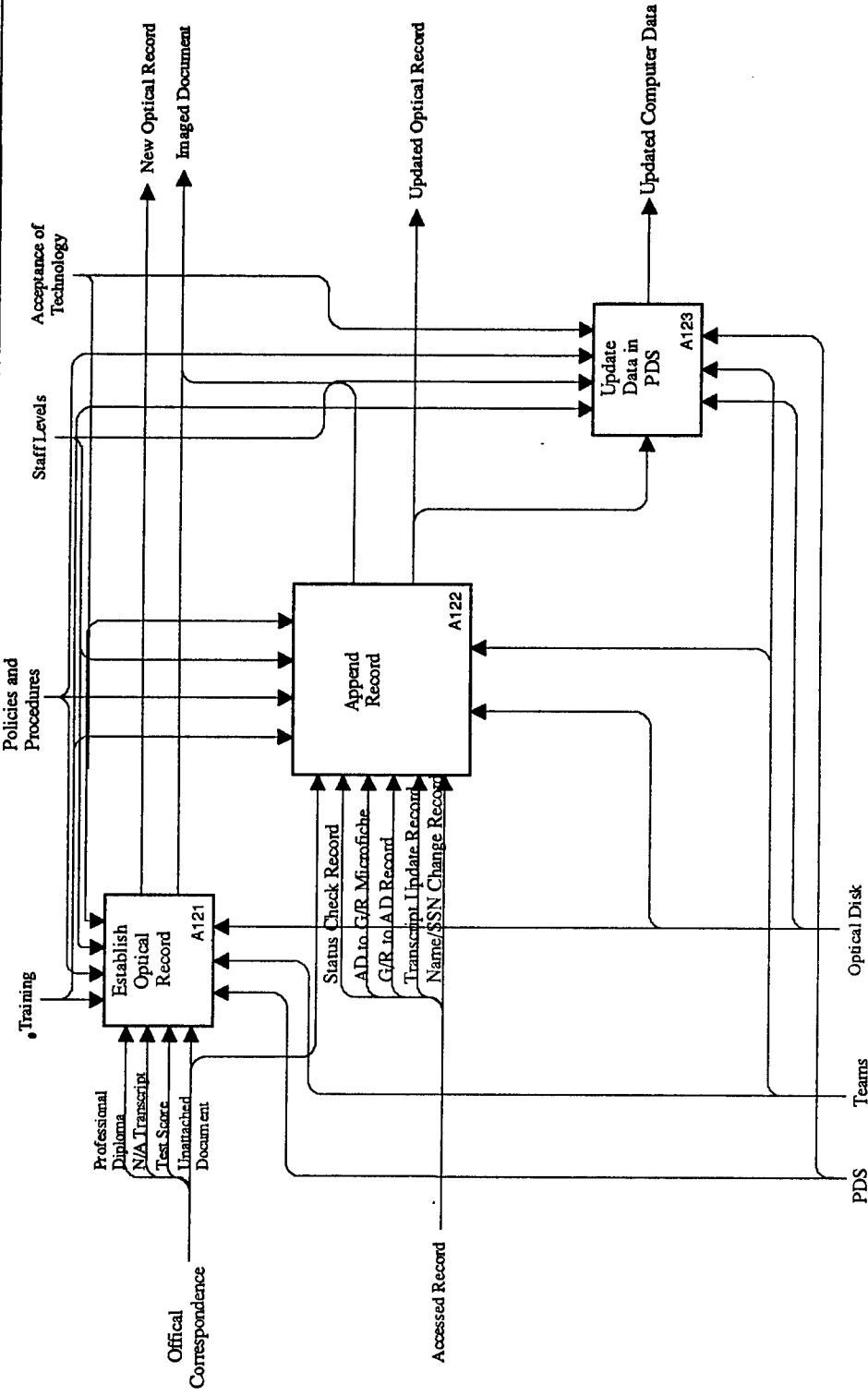

NODE: A12	TITLE: Create/ Correct Records	NUMBER:
-----------	--------------------------------	---------

USED AT:	AUTHOR: Capt Hutchinson/Capt McCoy PROJECT: APT/RAA	DATE: 26 September 1994 REV:	WORKING DRAFT	READER	DATE	CONTEXT:
	NOTES: 1 2 3 4 5 6 7 8 9 1C		X RECOMMENDED			<input type="checkbox"/>
			PUBLICATION			<input type="checkbox"/>

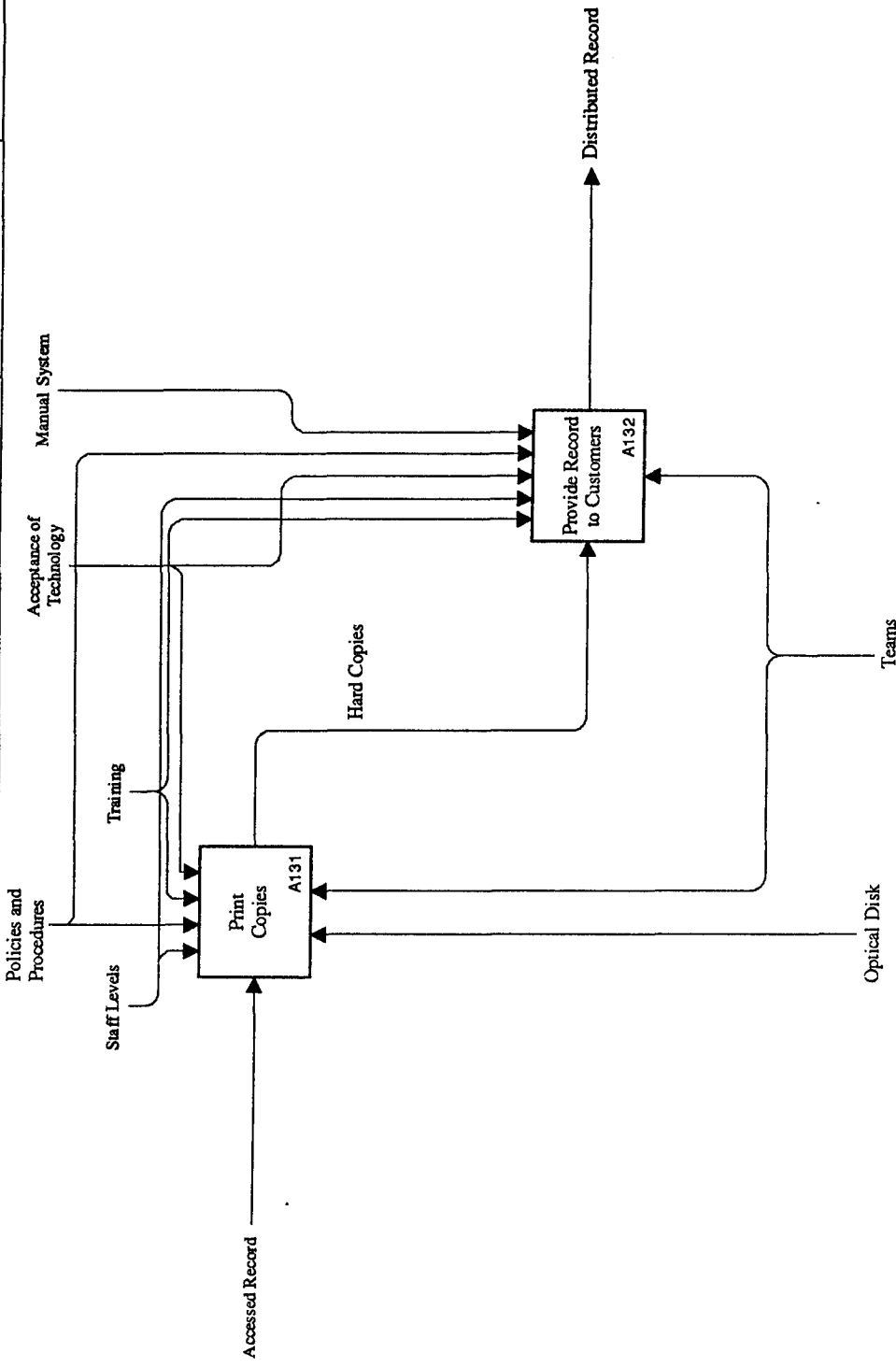

NODE: A13	TITLE: Distribute Records	NUMBER:
-----------	---------------------------	---------

USED AT:	AUTHOR: Capt Hutchinson/Capt McCoy	DATE: 26 September 1994	READER	DATE	CONTEXT:
PROJECT: AFIT/RRR	REV:		WORKING		<input type="checkbox"/>
NOTES: 1 2 3 4 5 6 7 8 9 10			DRAFT		<input type="checkbox"/>
			RECOMMENDED		<input checked="" type="checkbox"/>
			PUBLICATION		<input type="checkbox"/>

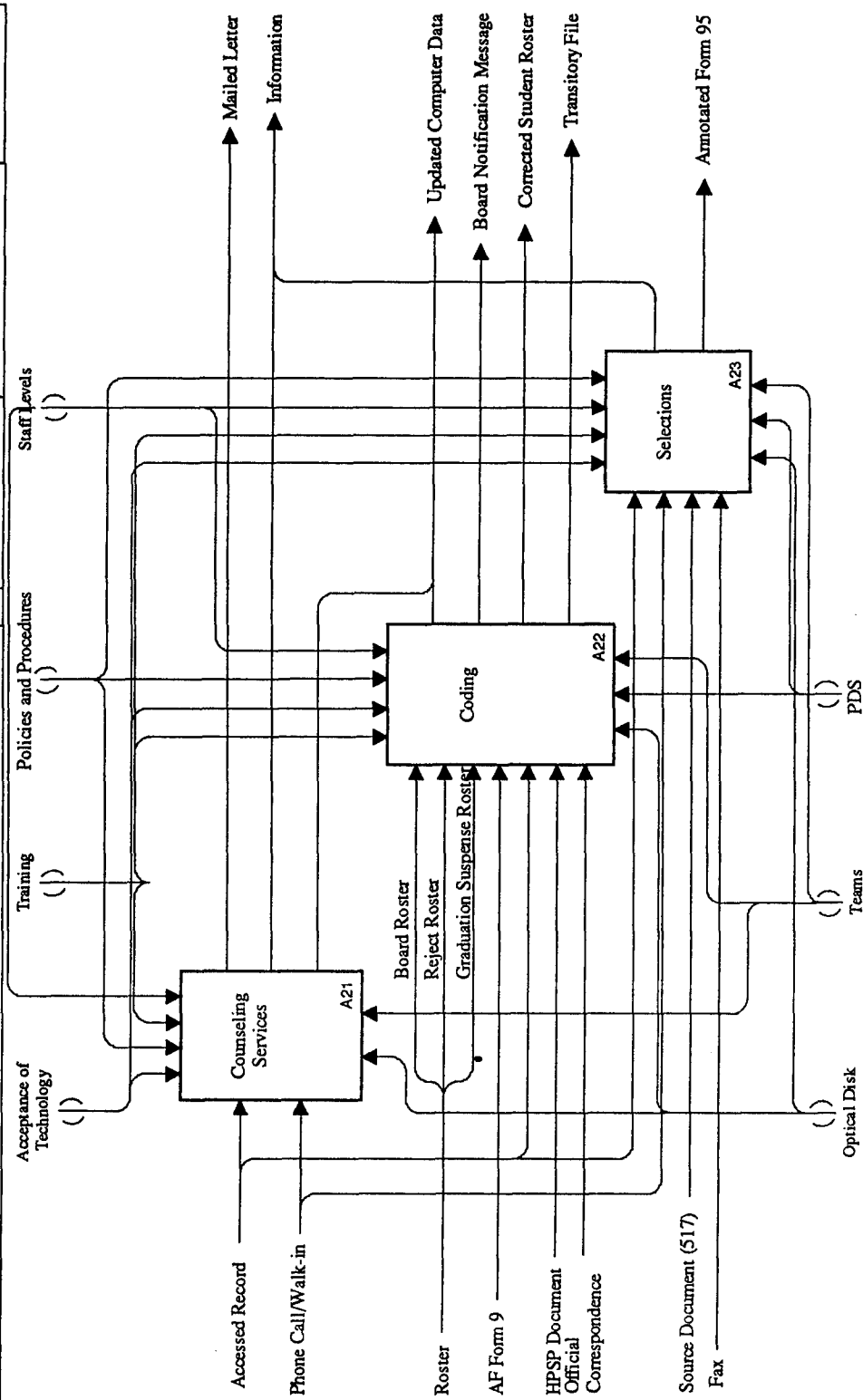

NODE: A2	TITLE: Maintain Records	NUMBER:
----------	-------------------------	---------

USED AT:	AUTHOR: Capt. Huchinson/Capt. McCoy	DATE: 26 September 1994	WORKING	READER	DATE	CONTEXT:
PROJECT: AFIT/RRR	REV:		DRAFT			<input type="checkbox"/>
NOTES: 1 2 3 4 5 6 7 8 9 10			X RECOMMENDED			<input type="checkbox"/>
			PUBLICATION			<input type="checkbox"/>

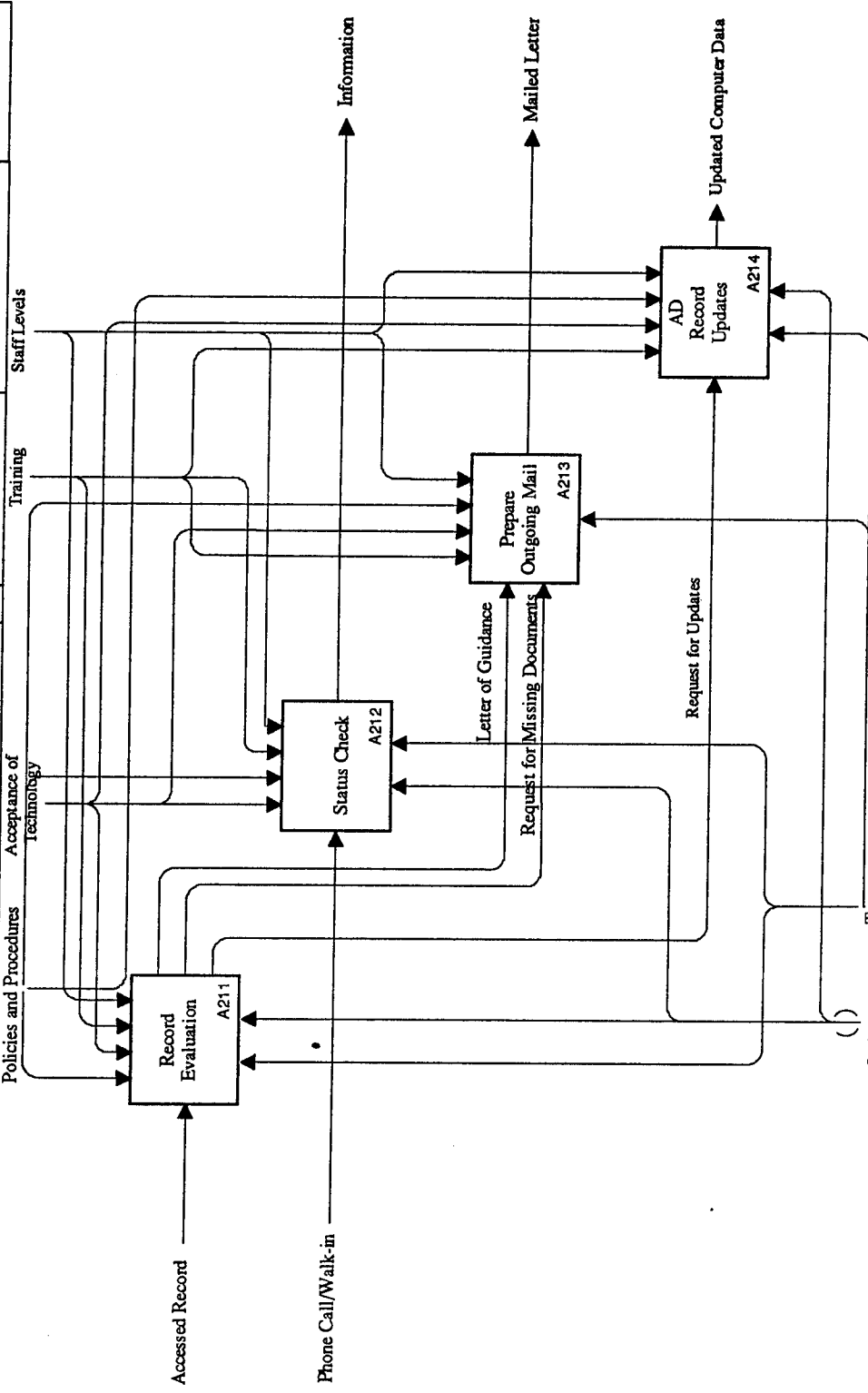

NODE: A21	Optical Disk Teams	NUMBER:
TITLE: Counseling Services		

USED AT:	AUTHOR: Capt Hutchinson/Capt McCoy	DATE: 26 September 1994	READER	DATE	CONTEXT:
PROJECT: AFIT/RRR	REV:				<input type="checkbox"/>
NOTES: 1 2 3 4 5 6 7 8 9 1C			WORKING		<input type="checkbox"/>
			DRAFT		<input type="checkbox"/>
			X RECOMMENDED		<input checked="" type="checkbox"/>
			PUBLICATION		<input type="checkbox"/>

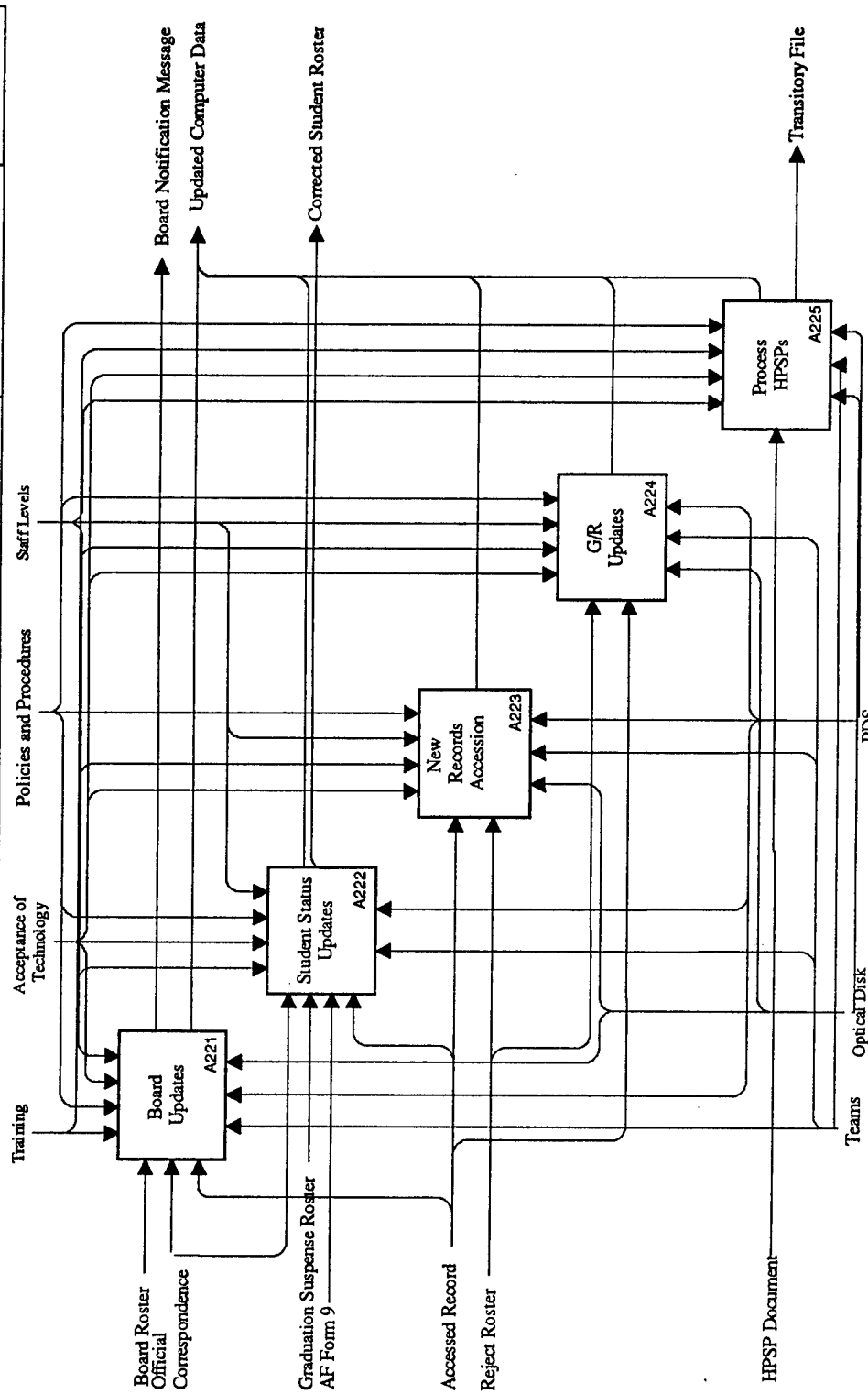

NODE: A22	TITLE: Coding	NUMBER:
-----------	---------------	---------

USED AT:	AUTHOR: Capt Hutchinson/Capt McCoy	DATE: 26 September 1994	WORKING	READER	DATE	CONTEXT:
	PROJECT: AFIT/RRR	REV:	DRAFT			<input type="checkbox"/>
	NOTES: 1 2 3 4 5 6 7 8 9 1C		X RECOMMENDED			<input type="checkbox"/>
			PUBLICATION			<input checked="" type="checkbox"/>

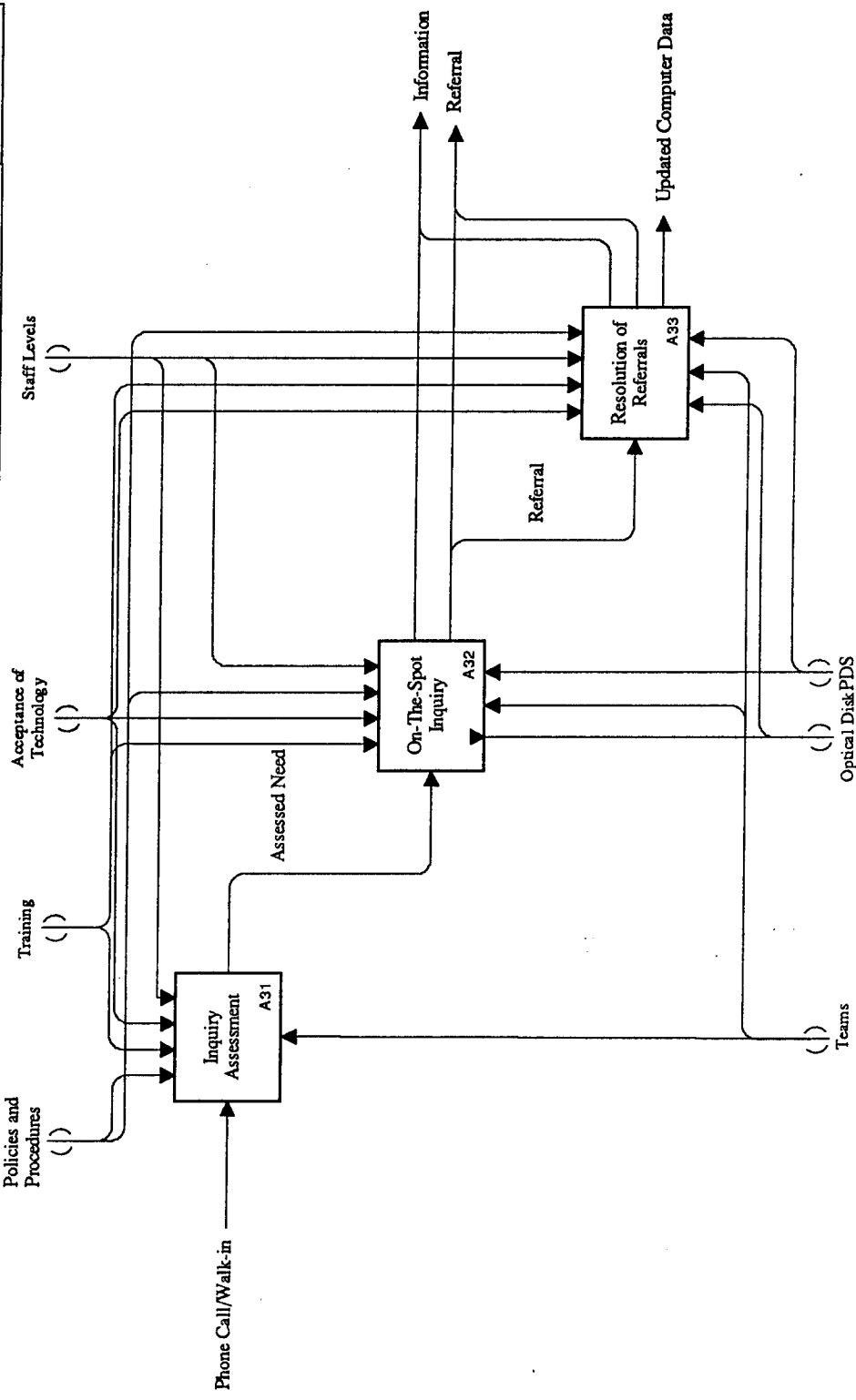

NODE: A3	TITLE: Provide Customer Service	NUMBER:
----------	---------------------------------	---------

USED AT:	AUTHOR: Capt Hutchinson/Capt McCoy	DATE: 26 September 1994	READER	DATE	CONTEXT:
	PROJECT: AFIT/RRR	REV:	WORKING		<input type="checkbox"/>
	NOTES: 1 2 3 4 5 6 7 8 9 10		DRAFT		<input type="checkbox"/>
			X RECOMMENDED		<input checked="" type="checkbox"/>
			PUBLICATION		<input type="checkbox"/>

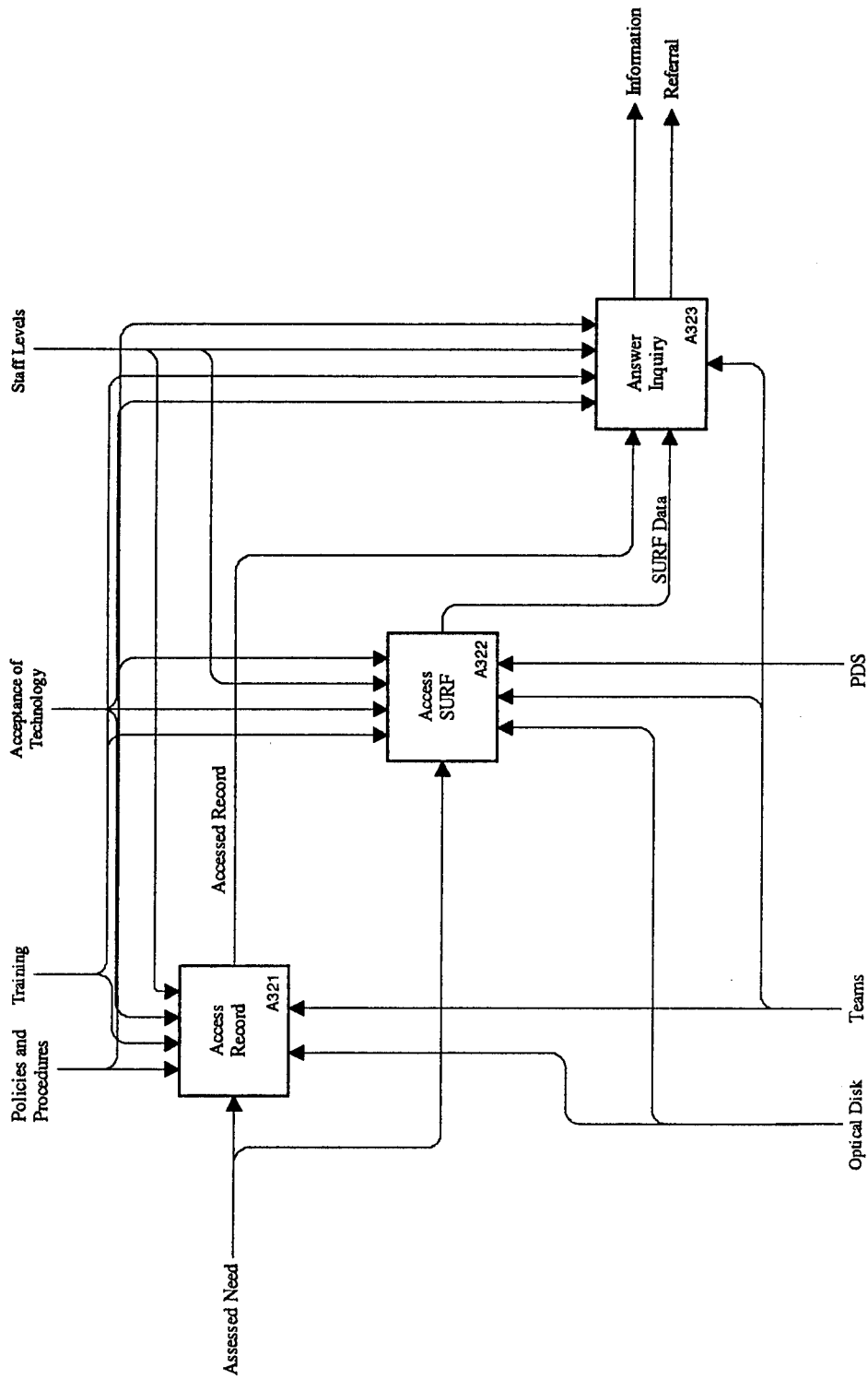

NODE: A32	TITLE: On-The-Spot Inquiry	NUMBER:
-----------	----------------------------	---------

USED AT:	AUTHOR: Capt Hutchinson/Capt McCoy	DATE: 26 September 1994	WORKING	READER	DATE	CONTEXT:
	PROJECT: AFT/RRR	REV:	DRAFT			<input type="checkbox"/>
	NOTES: 1 2 3 4 5 6 7 8 9 10		X RECOMMENDED			<input type="checkbox"/>
			PUBLICATION			<input type="checkbox"/>

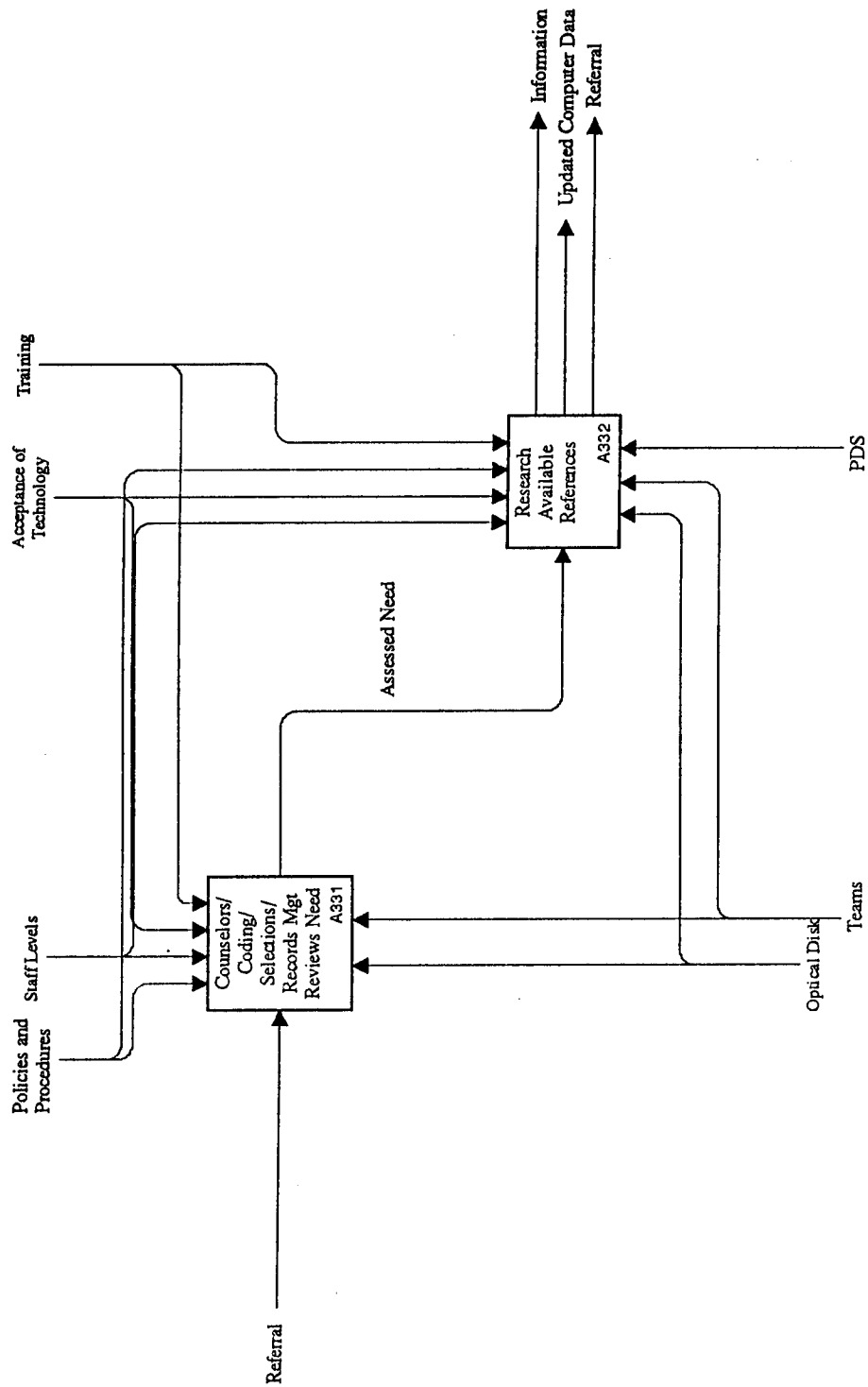

NODE: A33	TITLE: Resolution of Referrals	NUMBER:
-----------	--------------------------------	---------

Appendix E: Glossary for "TO-BE" Model

This glossary defines all terms used in the IDEF0 model in Appendix D. All activity and ICOM (inputs, controls, outputs, and mechanisms) names are presented to facilitate communication with individuals wishing to use the previously mentioned IDEF0 models.

ACCEPTANCE OF TECHNOLOGY - The TEAMS' level of acceptance and willingness to use the new OPTICAL DISK technology.

ACCESS RECORDS - A child or component activity of the CONTROL RECORDS activity. This process allows for opening an OPTICAL RECORD through the OPTICAL DISK system.

ACCESS SURF - The retrieval of data in the PDS on a specific officer.

ACCESSED RECORD - An OPTICAL RECORD that has been accessed through the OPTICAL DISK system.

AD RECORD UPDATES - The updating of an active duty officer OPTICAL RECORD by COUNSELING SERVICES.

AF FORM 9 - Air Force form generated by the Civilian Institutes Division that indicates completion of civilian institute-sponsored degrees. Used by CODING to update officer data in the PDS.

ANNOTATED FORM 95 - An Air Force form used by SELECTIONS that reflect AFIT program requirements, current grade point average for officer and memos for record from CODING and COUNSELING SERVICES.

ANSWER INQUIRY - Resolving a CUSTOMER'S ON-THE-SPOT INQUIRY.

APPEND RECORD - A child or component activity of the CREATE/CORRECT RECORDS activity. This process allows for adding information to an ACCESSED RECORD.

ASSESSED NEED - The determined need of a PHONE CALL/WALK-IN customer.

BOARD NOTIFICATION MESSAGE - A message prepared by CODING to provide AFMPC officer data used by officer promotion boards.

BOARD ROSTER - A type of ROSTER forwarded from AFMPC for verification of officer data prior to the convening of officer promotion boards.

BOARD UPDATES - The process of providing AFMPC data for officer promotion boards.

CODING - A child or component activity of the MAINTAIN RECORDS activity that updates officer education data in the PDS.

CONTROL RECORDS - A child or component activity of the **MANAGE RECORDS** activity. The process which allows for creating, retrieving, refiling, and distributing a record. This process owns the physical substance of a record.

CORRECTED STUDENT ROSTER - A **ROSTER** that has been corrected to reflect a **STUDENT STATUS UPDATE**.

COUNSELING SERVICES - A child or component activity of the **MAINTAIN RECORDS** activity that evaluates officer education records and provides guidance for eligibility for **AFIT** programs.

COUNSELORS/CODING/SELECTIONS/RECORDS MANAGEMENT REVIEWS NEED - The evaluation of a **CUSTOMER'S** needs by one or more of the named areas.

CREATE/CORRECT RECORDS - A child or component activity of the **CONTROL RECORD** activity. The process which allows for the creation of the initial record; includes initiation of an **AF Form 614**.

DISTRIBUTE RECORDS - A child or component activity of the **CONTROL RECORD** activity. The process which allows for the distribution of **HARD COPIES** to other agencies, both within and outside **AFIT/RR**, and individual customers.

DISTRIBUTED RECORD - HARD COPIES that have been distributed to another agency, either within or outside **AFIT/RR**, or an individual customer.

DOCUMENT - Forms or letters that become part of the **OPTICAL RECORD** or generate actions on the **OPTICAL RECORD**. Includes: **AFIT Form 68**, **AFIT Form 95**, official transcript(s), **GMAT** or **GRE** test scores, request for evaluation letter(s), and other official correspondence.

ESTABLISH OPTICAL RECORD - A child or component activity of the **CREATE/CORRECT RECORDS** activity. This process allows for beginning new records upon receipt of the appropriate **OFFICIAL CORRESPONDENCE**.

EXTRANEIOUS DOCUMENT - Any document that can not or should not be placed in an **OPTICAL RECORD** or can not or should not cause a **NEW OPTICAL RECORD** to be established. **DOCUMENTS** that are incomplete/unacceptable or that cannot be matched to an **OPTICAL RECORD**.

FAX - Information transmitted by facsimile to the **SELECTIONS** section.

G/R UPDATES - The updating of an Air National Guard or Air Force Reserve officer **OPTICAL RECORD** by **CODING**.

GRADUATION SUSPENSE ROSTER - A type of ROSTER that identifies officers pending graduation from an AFIT program.

HARD COPIES - Paper copies of records produced for the PROVIDE RECORD TO CUSTOMERS process.

HPSP DOCUMENT- Health Professional Scholarship Program document used by CODING to place an officer in student status.

IMAGED DOCUMENT - A document whose information has been transferred to an OPTICAL RECORD on the OPTICAL DISK system as the result of the ESTABLISH OPTICAL RECORD process.

INFORMATION - Responses (written or oral) to inquiries.

INQUIRY ASSESSMENT - The determination of a PHONE CALL/WALK-IN CUSTOMER'S needs.

LETTER OF GUIDANCE - Correspondence generated by COUNSELING SERVICES as a result of the RECORD EVALUATION process.

MAILED LETTER - Outgoing correspondence.

MAINTAIN RECORDS - A child or component activity of the MANAGE RECORDS activity. This process allows for the update, purging and evaluation of records and the preparation of microfiche. This process owns the "status" of the record.

MANAGE EDUCATION RECORDS - The parent activity which decomposes into the CONTROL RECORDS, MAINTAIN RECORDS, and PROVIDE CUSTOMER SERVICE child activities. This project will only focus on one of the child activities, CONTROL RECORDS.

MANUAL SYSTEM - The present system of manually creating, retrieving, and refilling records.

N/A (New Accession) TRANSCRIPT - A transcript received on newly commissioned officers.

NAME/SSN CHANGE RECORD - An ACCESSED RECORD that requires correction due to a change or error in the officer's name or social security number.

NEW OPTICAL RECORD - A record on the OPTICAL DISK system that has been produced as a result of the ESTABLISH OPTICAL RECORD process.

NEW RECORDS ACCESSION - The updating of the PDS and RECORD by CODING of a newly commissioned officer.

OFFICIAL CORRESPONDENCE - A general term that includes PROFESSIONAL DIPLOMA, N/A (NEW ACCESSION) TRANSCRIPT, TEST SCORE, and UNATTACHED DOCUMENT.

ON-THE-SPOT INQUIRY - The immediate resolution of a PHONE CALL/WALK-IN CUSTOMER'S need.

OPTICAL DISK system - A completely integrated document image storage and retrieval system which provides AFIT/RR the means to scan images, store, retrieve, update, manage work flow, and transmit existing and future academic documents.

OPTICAL RECORD - A digitally stored image of an academic record that is stored on WORM optical disk storage media.

PDS - The Personnel Data System (PDS). AFIT/RR is the sole update source for all officer academic data in the PDS. The PDS runs on a Honeywell DPS8 computer system under the GCOS operating system.

PHONE CALL/WALK-IN - An inquiry from a CUSTOMER that is either initiated by telephone or by the CUSTOMER in person.

POLICIES AND PROCEDURES - The regulations or manuals which provide guidance for the RECORDS AND SYSTEMS MANAGEMENT DIVISION. Includes: AFIT/RRA Operating Instruction, AFM 30-130 Volume 1, AFR 35-25, AFR 36-1, AFCAT 36-2223, AURP 53-2 Volume 17 Number 1, and AFR 700-20 Volume I.

PREPARE OUTGOING MAIL - The final preparation by the COUNSELING SERVICES secretary of correspondence generated by a counselor.

PRINT COPIES - A child or component activity of the DISTRIBUTE RECORDS activity. This process allows for the production of HARD COPIES for the PROVIDE RECORD TO CUSTOMERS process.

PROCESS HPSPs - The updating of the PDS to place an officer who has received a Health Professional Scholarship into student status.

PROVIDE CUSTOMER SERVICE - The process that interfaces directly with the customer to attempt to provide on-the-spot information.

PROVIDE RECORD TO CUSTOMERS - A child or component activity of the **DISTRIBUTE RECORDS** activity. This process allows for delivering the **HARD COPIES** to a customer.

RECORD EVALUATION - The evaluation of a **RECORD** by a counselor to determine an officer's eligibility for an **AFIT** program.

REFERRAL - A referred record that results from the **ON-THE-SPOT-INQUIRY** process.

REJECT ROSTER - A type of **ROSTER** used by **CODING** that indicates data input errors.

REQUEST FOR MISSING DOCUMENTS - Correspondence generated by a counselor to notify an officer that evaluation of his/her education record cannot be completed until the officer supplies the requested missing information.

REQUEST FOR UPDATES - Within **COUNSELING SERVICES**, a request made by the **RECORD EVALUATION** process to the **AD RECORD UPDATES** process to make updates to a record.

RESEARCH AVAILABLE REFERENCES - The consultation of reference materials to answer a **CUSTOMER'S ASSESSED NEED**.

RESOLUTION OF REFERRALS - The resolution of a **CUSTOMER'S** needs within the **MANAGE EDUCATION RECORDS** process.

ROSTER - **ATLAS LISTS** and other computer generated reports that are initiated both at **AFMPC** and locally. Includes: Transaction Rosters (**TRs**); purge rosters; name change rosters; quality check rosters; Health Professions Scholarship Program Roster; reject/error rosters.

SELECTIONS - A child or component activity of the **MAINTAIN RECORDS** activity that chooses officers for **AFIT** programs.

SOURCE DOCUMENT - Air Force Form 517 used by the **SELECTIONS** section for determining officer eligibility for an **AFIT** program.

STAFF LEVELS - The number and training level of personnel in the **RECORDS AND SYSTEMS MANAGEMENT DIVISION**.

STATUS CHECK - An on-the-spot evaluation of an officer's **RECORD** by a counselor in response to a **SCREENED CALL**.

STUDENT STATUS UPDATES - The updating of information in the PDS to indicate that an officer is enrolled in an AFIT program.

SURF (Search Under Record File) DATA- Computer data maintained on an officer.

TEAMS - A work team that is composed on a counselor, a coder, and an administrative clerk.

TEST SCORE - Forwarded GRE or GMAT test results.

TRAINING - Hands-on and classroom instruction on the used of the OPTICAL DISK system.

TRANSITORY FILE - A file that contains temporary documents or correspondence.

UNATTACHED DOCUMENT - Any existing or new professional diploma, new accession transcript, test scores, or official correspondence, etc. that has been examined by PERSONNEL and initiates the CREATE/CORRECT RECORDS process.

UPDATE DATA IN PDS - Personal data is altered in the PERSONNEL DATA SYSTEM.

UPDATED COMPUTER DATA - Corrections, changes, and/or updates to a RECORD that are entered in to the PDS and used by outside organizations.

UPDATED OPTICAL RECORD - Corrections, changes, and/or updates to an OPTICAL RECORD that are entered in to the OPTICAL DISK system. Includes unofficial records, which are valid for 45 days or until the individual(s) sends new document(s).

Appendix F: Exploratory Interviews

At the initiation of the thesis research, exploratory interviews were conducted with a sampling of the personnel involved in the Manage Education Records process. The purpose of conducting these interviews was to obtain a tentative understanding of the objectives of the records management process. The following section contains the comments of the personnel interviewed.

INTERVIEW #1

Position/Job Title	Records Clerk
Rank/Pay grade	GS-4/Step 7
What do you do?	<ul style="list-style-type: none"> - Responsible maintaining records Q-Z - File transcripts (30-40 new/day) <ul style="list-style-type: none"> -- Checks files for existing record -- No record, do a SERF check -- Build record, type label -- Complete charge-out card -- Send record to coding - File records returned from coding or other department. - Pull records, send to coding for updating - Changes name labels on all records - Answers phone calls <ul style="list-style-type: none"> -- 8-9 incoming lines, all go through records -- Transfers calls to other departments -- "Typical" call: check for record update (accomplished by records) <ul style="list-style-type: none"> --- Questions for counselors transferred to counselors --- Record pulled and walked to counselor
How were you trained?	<ul style="list-style-type: none"> - On-the-job training - Read Operating Instructions - Keeps personal notes on items not covered by Operating Instructions - Attended basic computer course
What are the required inputs?	<ul style="list-style-type: none"> - Computer database - Transcripts/mail: GRE/GMAT, AFIT Forms, correspondence - Phone calls - Files for filing - Rosters
How do you know your output is good?	<ul style="list-style-type: none"> - Feedback from customers (phone calls, coding) - Feedback from supervisor and annual appraisal
Who are your customers?	<ul style="list-style-type: none"> - AF officers - Coding section - Counselors - Civilian Institute section - Education offices at other bases
What keeps you from doing error-free work?	<ul style="list-style-type: none"> - Charged out records that are misplaced (5-7 each week) - Rude telephone callers - Down computers

INTERVIEW #1 (continued)

<p>What can be done to make your job easier?</p>	<ul style="list-style-type: none"> - Have other sections answer their own calls <ul style="list-style-type: none"> -- Other sections allowed to leave office unattended during lunch and forwards calls to records, records always manned - Make people more responsible for charged our records <ul style="list-style-type: none"> -- If charged out to another office, that office needs to update card if record taken to another office - New accession evaluations falls behind on coding causing a backlog for others - Other sections should pull own records <ul style="list-style-type: none"> -- Records sections occasionally get requests for 150+ records
<p>How do you let your suppliers know how well they are performing?</p>	<ul style="list-style-type: none"> - Tell them, voice complaints
<p>What would happen if you did not do the job?</p>	<ul style="list-style-type: none"> - There would be a backlog of work <ul style="list-style-type: none"> -- Can't miss more than 2 days without falling behind -- If gone for extended period, slack picked up by others
<p>Have you reviewed your job description?</p>	<ul style="list-style-type: none"> - Yes <ul style="list-style-type: none"> -- Works within guidelines, but would like more challenge
<p>What would happen if each of your suppliers stopped providing you with input?</p>	<ul style="list-style-type: none"> - Would have no work
<p>What would change if you were the manager?</p>	<ul style="list-style-type: none"> - Better Lektrievers (record filing cabinets) - Task other sections to pull their records - Better microfiche reader - Require everyone to do their job

INTERVIEW #2

Position/Job Title	Records Clerk
Rank/Pay grade	GS-4/Step 5
What do you do?	<ul style="list-style-type: none"> - Answer phone calls <ul style="list-style-type: none"> -- 80% of day --- 75% of calls for records, rest for counselors --- 30% of the time multiple calls are handled at once (2-8 lines at once) - Customer service - Maintain records G-P <ul style="list-style-type: none"> -- No record, check computer for record in database - Pull records 20% of time - Receive mail - Sort transcripts - Place records in Coding cabinet, one drawer for AD, one for Reserve and Guard - Create new accession records <ul style="list-style-type: none"> -- Check in computer for status code -- Make record/type label and 614 Charge out card) -- Send record to New Accessions -- File 614 with record charged out to new accessions - Type labels for changed names - Purge records twice a week (150-300 records per week for entire purge, divided among clerks) - Track down lost records <ul style="list-style-type: none"> -- 25% of time -- 10 min. to 3 days per record -- 20 records per week lost -- Usual cause is record routed to another section with out updating 614
How were you trained?	<ul style="list-style-type: none"> - "Common Sense" - On-the-job training - Read Operating Instructions, share information with others - Attended basic computer class - Attended class on telephone etiquette
What are the required inputs?	<ul style="list-style-type: none"> - Transcripts - New accession listings - Files returned from coding - Phone calls
How do you know your output is good?	<ul style="list-style-type: none"> - Telephone calls from customers praising work

INTERVIEW #2 (continued)	
Who are your customers?	<ul style="list-style-type: none"> - Phone callers - Walk-ins - Coding section - Counselors
What keeps you from doing error-free work?	<ul style="list-style-type: none"> - Too many phone calls at once; easy to confuse, easy to get side tracked - Lost records - Too much work
What can be done to make your job easier?	<ul style="list-style-type: none"> - Update 614 when records go to a different office - Work as a <u>TEAM</u> rather than individuals - Focus on service as a team
How do you let your suppliers know how well they are performing?	<ul style="list-style-type: none"> - Go to individual first, then supervisor
What would happen if you did not do the job?	<ul style="list-style-type: none"> - Others would pick up the slack
Have you reviewed your job description?	<ul style="list-style-type: none"> - Yes, accurate
What would happen if each of your suppliers stopped providing you with input?	<ul style="list-style-type: none"> - There would be no work
What would change if you were the manager?	<ul style="list-style-type: none"> - Every 2 weeks hold feedback meetings with staff on how to improve service - Cross-train staff in other sections in order to help pick up slack and get better view of big picture <ul style="list-style-type: none"> -- Would increase job satisfaction and help to understand why others do the things they do - Commented that things get backed up due to being shorthanded. When asked what he would do if he had an extra body to put anywhere he wanted he said he'd use them as back up to help in areas that are falling behind, answer calls, search for lost records.

INTERVIEW #3

INTERVIEW #3	
Position/Job Title	Coding technician (751X0)
Rank/Pay grade	E-4
What do you do?	<ul style="list-style-type: none"> - Updates records into the computer system, 100-125 per day <ul style="list-style-type: none"> -- Record sent from records clerk -- AFIT form 95 (Educational record) manually updated from transcript -- Update data in computer <ul style="list-style-type: none"> --- batch file sent to AFMPC every few days - Quality control: AFMPC sends weekly error listing, 2-3 errors per week - Requests from counselors for updating of record to suggest courses or program <ul style="list-style-type: none"> --AFIT form 68 (Academic screening record) submitted by counselor -- Coding could be done by counselor - Promotion Board updates <ul style="list-style-type: none"> -- 1 week prior and during the board, AFIT can send message (Email) to board. -- Does not Quality control system to check if message flowed -- 3 months prior to board, receives board audit from AFMPC requesting information on incomplete records, coding checks computer for missing information - Answers phones if busy up front - Mission: To make sure the education record of every officer is current
How were you trained?	<ul style="list-style-type: none"> - On-the-job training - Operating Instructions - AFR 35-25
What are the required inputs?	<ul style="list-style-type: none"> - Education record - Error listing
How do you know your output is good?	<ul style="list-style-type: none"> - Error listing from AFMPC - Officers review record and contact office - Exception reports - System will alert if unrecognized codes are entered
Who are your customers?	<ul style="list-style-type: none"> - All AF Officers - AFMPC <ul style="list-style-type: none"> -- Resource managers -- Promotion boards - Base CBPO - Records clerks

INTERVIEW #3 (continued)

What keeps you from doing error-free work?	<ul style="list-style-type: none"> - Human error - Down computer - Lack of complete information
What can be done to make your job easier?	<ul style="list-style-type: none"> - More people in coding to help <ul style="list-style-type: none"> -- Doesn't fall behind but said she could use the extra time to complete upgrade training
How do you let your suppliers know how well they are performing?	<ul style="list-style-type: none"> - Tell them by letter to officers(rarely) - Verbally - Must assume information from counselors is correct
What would happen if you did not do the job?	<ul style="list-style-type: none"> - Records would not be updated - If absent, job will not be picked up by others unless there is an upcoming promotion board <ul style="list-style-type: none"> -- Believes the her work will not be handled during the 6-wk maternity leave
Have you reviewed your job description?	<ul style="list-style-type: none"> - Yes <ul style="list-style-type: none"> -- Enlisted Performance Report doesn't accurately reflect duties
What would happen if each of your suppliers stopped providing you with input?	<ul style="list-style-type: none"> - Job wouldn't exist - Central repository for education records needs to exist
What would change if you were the manager?	<ul style="list-style-type: none"> - Let counselors code (a task they performed at one time) - Have Civilian Institutes enter start/stop dates - Get people that want to do this job (implying that staff is not motivated due to boredom) - Move people around more to avoid burnout

INTERVIEW #4	
Position/Job Title	Personnel Systems Manager (73170)
Rank/Pay grade	E-6
What do you do?	<ul style="list-style-type: none"> - Run ATLAS (retrieval programs) <ul style="list-style-type: none"> -- Can access all AF database -- Selective reports on specific information -- AFIT/CC requests <ul style="list-style-type: none"> --- Thesis studies -- Error rosters for coding - Print daily updates - Establishes code tables for schools and majors <ul style="list-style-type: none"> -- New codes defined and title developed by Civilian Institutes - Troubleshoots problems on computers <ul style="list-style-type: none"> -- Calls Randolph AFB if can't resolve
How were you trained?	<ul style="list-style-type: none"> - On-the-job training - AFSC training - Operating Instructions on downloading and printing
What are the required inputs?	<ul style="list-style-type: none"> - Requests for ATLAS - Weekly and monthly requirements <ul style="list-style-type: none"> -- AFIT Orderly Room <ul style="list-style-type: none"> --- Gain/loss statistics --- Security lists -- Public Affairs <ul style="list-style-type: none"> --- Promotions --- AFIT student lists -- Wright Lab <ul style="list-style-type: none"> --- Lists of personnel that can be used in a lab -- AFIT/XP <ul style="list-style-type: none"> --- Listing of staff/faculty and accomplishments - Requests for changes on codes
How do you know your output is good?	<ul style="list-style-type: none"> - Periodically checks own ATLAS - Asks customers for feedback (do you still need this report?)
Who are your customers?	<ul style="list-style-type: none"> - AFIT <ul style="list-style-type: none"> - Main base - HQAF - AOG (Association of graduates) <ul style="list-style-type: none"> -- Outside agencies must submit letter of request - AFMPC - Students

INTERVIEW #4 (continued)	
What keeps you from doing error-free work?	<ul style="list-style-type: none"> - Requests via letter may not explain exact request - Civilian Institutes requests are a little different, requires a different code
What can be done to make your job easier?	<ul style="list-style-type: none"> - Nothing, work load not that great
How do you let your suppliers know how well they are performing?	<ul style="list-style-type: none"> - Talk to them
What would happen if you did not do the job?	<ul style="list-style-type: none"> - Coders could retrieve errors - AFMC has ATLAS shop (believes her position is redundant)
Have you reviewed your job description?	<ul style="list-style-type: none"> - Yes
What would happen if each of your suppliers stopped providing you with input?	<ul style="list-style-type: none"> - Wouldn't have anything to do
What would change if you were the manager?	<ul style="list-style-type: none"> - Move position to AFIT/DP or delete position entirely (use MAJCOM ATLAS)

INTERVIEW #5

Position/Job Title	Chief, Officer Academic Repository
Rank or Pay grade	GS-12
What do you do?	<ul style="list-style-type: none"> - Knowledge of PDS system, conduct computer record searches and request ATLAS reports - Airman Education Commissioning Program monitor <ul style="list-style-type: none"> -- Monitors 100 applications per year -- Determines if applicant is academically qualified - AFMPC Academic Consultant for AECF board - Creates AFIT Ed Newsletter <ul style="list-style-type: none"> -- Distributed to all Education Services Offices -- Printed 1-2 times a year - Trouble-shoots all kinds of problems, including personnel-oriented - Optical imaging system honcho - Takes phone calls - Develops new codes (school and education codes) - Manages 11 people - Publishes AFIT catalog - AFIT/RR representative for Computer Systems Requirement Board - Receives transaction roster - Reviews computer inputs - Follows up on errors - Makes system inquiries - Interface with promotion boards - Provides information to boards for corrections to military records - Conducts individual training on computers
What are the required inputs?	<ul style="list-style-type: none"> - Access to PDS to do inputs and update records - Phone calls - Walk-in customers (4-5/day) - Correspondence/Email
What are the constraints?	<ul style="list-style-type: none"> - Operating Instructions - AFR 35-25 (Academic Classification and Coding Procedures) - AFR 36-1 (Officer Classification) - AFR 700-20 Vol. I - AF Cat 35-2223 (previously AFR 50-5) - AFR 53-20 (Commissioning Programs)

INTERVIEW #6

INTERVIEW #6	
Position/Job Title	Counselor
Rank or Pay grade	GS-9/Step 4
What do you do?	<ul style="list-style-type: none"> - Prepare Letters of Evaluation <ul style="list-style-type: none"> -- Only responds to requests for specific programs -- DOES NOT suggest programs -- If record short of information, send letter to officer explaining what is missing <ul style="list-style-type: none"> -- Flag record with blue suspense form so when information is received, the record will be returned to counselor - When eligible, letter of eligibility is sent to student with programs designated - Evaluate all new accession records for program eligibility <ul style="list-style-type: none"> -- Overall evaluation is verified by three people (original counselor, one other counselor, final by Chief, Counseling Services) - Evaluation letter typed by secretary and returned to counselor for review - Checks computer codes for accuracy - GPA conversion to equate all transcripts to semester system
What are the required inputs?	<ul style="list-style-type: none"> - Phone calls - Walk-in customers - Correspondence
How were you trained?	<ul style="list-style-type: none"> - Two years of on-the-job training to become a counselor - BA w/teaching certificate
What are the constraints?	<ul style="list-style-type: none"> - AFIT for 68 (Academic Screening Record) - AFIT for 95 (Educational Record) maintained in record - AFR 700-20 Vol. I (AF Data Dictionary) <ul style="list-style-type: none"> --contains all codes and definitions database maintained at Scott AFB- moved from Gunter, has been down for four months <ul style="list-style-type: none"> -- Must work off of 1990 microfiche - AFCAT 36-2223 (USAF Formal Schools)

Bibliography

- Carr, Jeffrey and Gene Tyndall. "Planes, Trains. . . And Trucks," Chief Information Officer Journal, 5: 58-61 (September/October 1993).
- Corbin, Lisa. "Reengineering: The Next Management Revolution," Government Executive, 25: 26-32 (September 1993).
- Davenport, Thomas H. and James E. Short. "The New Industrial Engineering: Information Technology and Business Process Redesign," Sloan Management Review, 31: 11-27 (Summer 1990).
- Dennis, Alan, Gigi Kelly, Glenda Hayes, Robert Daniels, Richard Orwig, and Doug Dean. "Business Process Re-Engineering with IDEF and Electronic Meeting Systems,"
- Department of Defense. Corporate Information Management Process Improvement Methodology for DoD Functional Managers. Washington: GPO, 1993.
- Department of Defense. Interim Management Guidance on Functional Process Improvement. DoD 8020.1-M. Washington: GPO, August 1992.
- Department of the Air Force. General Accounting and Finance Systems at Base Level. AFR 177-101. Washington: HQ USAF. 15 February 1991, with Interim Message Change Effective 1 January 1993.
- Gore, Al. From the Red Tape to Results: Report of the National Performance Review. Washington: GPO, 7 September 1993.
- Gulden, Gary K. and Robert H. Reck. "Combining Quality and Reengineering Efforts for Process Excellence," Information Strategy: The Executive's Journal, 8: 10-16 (Spring 1992).
- Hammer, Michael. "Reengineering Work: Don't Automate, Obliterate," Harvard Business Review: 104-112 (July-August 1990).
- Hammer, Michael and James Champy. Reengineering the Corporation. New York: HarperBusiness [sic], 1993.
- Harrington, H. James. "The Way to World Class Status," Journal for Quality and Participation, 14: 42-47 (March 1991).

Harrington, H. James. Business Process Improvement. New York: McGraw-Hill, Inc., 1991.

McDowell, Phillip W. and David W. Morgan. Business Process Improvement Applied To Written Temporary Duty Travel Orders Within The United States Air Force. MS thesis, AFIT/GIR/LAR/93D-10. School of Logistics and Acquisition Management, Air Force Institute of Technology (AETC), Wright-Patterson AFB OH, December 1993 (AD-A273977).

Moad, Jeff, "Does Reengineering Really Work?" Datamation, 39: 22-28 (1 August 1993).

Moore, John. "Business Process Re-engineering: Fed Go Back to the Drawing Board," Federal Computer Week Supplement, 20 September 1993: 18-28.

Office of Personnel Management (OPM). Civilian Pay Information: January 1993 General Schedule Hourly Pay Rates Table. Washington: OPM. Undated, Effective 1 January 1993.

Shoop, Tom. "Gore's Gamble," Government Executive, 25: 18-28 (July 1993).

Strassmann, Paul A. "The Policies, Processes, and Technologies of CIM," CrossTalk [sic], October 1992: 12-18.

Vita

Captain Connie C. Hutchinson was born in Bridgeport, Nebraska on 31 August 1964. She graduated from Sidney High School in Sidney, Nebraska in 1982 and attended the University of Wyoming, Laramie, graduating with a Bachelor of Arts in Criminology in May 1986. She was commissioned after graduating from Officer Training School in March 1987. She began as a Personnel Officer in the Quality Force Section of the 2d Bombardment Wing Consolidated Base Personnel Office at Barksdale AFB, Louisiana. She then served as the Protocol Officer, Eighth Air Force and as the Operations Officer of the Shreveport Military Entrance Processing Station (MEPS). During her tour at Barksdale AFB she earned a MBA from Louisiana Technical University. Prior to moving to Wright Patterson AFB, she attended Squadron Officer School in residence. She entered the School of Logistics and Acquisition Management, Air Force Institute of Technology, in 1993. Upon graduation, Captain Hutchinson will be assigned to the Air Intelligence Agency located at Kelly AFB, TX.

Permanent Address: 1572 Burns Court
Fairborn, OH 45324

Vita

Captain Alison "Lisa" F. McCoy was born in Los Angeles, California on 23 February 1956. She graduated from Winston Churchill High School in Eugene, Oregon in 1974 and attended Lane Community College in Eugene, graduating with an Associate of Arts Degree in Dental Hygiene. After working for four years as a Registered Dental Hygienist in the Eugene area, she joined the U.S. Air Force as an Airman First Class. While stationed at Misawa AFB, Japan, she completed a Bachelor's Degree in Psychology through the University of Maryland, Asian Division. She received a regular commission in June 1988 after completing Officers' Training School as a Distinguished Graduate. Her first assignment as a commissioned officer was at Robins AFB as the Executive Officer for the 19th Field Maintenance Squadron. She then served as the Chief, Executive Services Division at the Air War College at Maxwell AFB, Alabama. During this time she attended Squadron Officer School in residence. She entered the School of Logistics and Acquisition Management, Air Force Institute of Technology, in 1993. Upon graduation, Captain McCoy will be assigned to Aviano AFB, Italy as the Base Information Manager.

Permanent Address: 3155 SW Quartz Place
Redmond, Oregon 97756

REPORT DOCUMENTATION PAGE

Form Approved
OMB No. 0704-0188

Public reporting burden for this collection of information is estimated to average 1 hour per response, including the time for reviewing instructions, searching existing data sources, gathering and maintaining the data needed, and completing and reviewing the collection of information. Send comments regarding this burden estimate or any other aspect of this collection of information, including suggestions for reducing this burden, to Washington Headquarters Services, Directorate for Information Operations and Reports, 1215 Jefferson Davis Highway, Suite 1204, Arlington, VA 22202-4302, and to the Office of Management and Budget, Paperwork Reduction Project (0704-0188), Washington, DC 20503.

1. AGENCY USE ONLY (Leave blank)		2. REPORT DATE December 1994		3. REPORT TYPE AND DATES COVERED Master's Thesis	
4. TITLE AND SUBTITLE BUSINESS PROCESS RE-ENGINEERING APPLIED TO THE AIR FORCE INSTITUTE OF TECHNOLOGY OFFICE OF THE REGISTRAR, RECORDS MANAGEMENT				5. FUNDING NUMBERS	
6. AUTHOR(S) Connie C. Hutchinson, Captain, USAF Alison F. McCoy, Captain USAF					
7. PERFORMING ORGANIZATION NAME(S) AND ADDRESS(ES) Air Force Institute of Technology, WPAFB OH 45433-6583				8. PERFORMING ORGANIZATION REPORT NUMBER AFIT/GIR/LAR/94D-5	
9. SPONSORING/MONITORING AGENCY NAME(S) AND ADDRESS(ES) AFIT/RR WPAFB OH 45433-6583				10. SPONSORING/MONITORING AGENCY REPORT NUMBER	
11. SUPPLEMENTARY NOTES					
12a. DISTRIBUTION / AVAILABILITY STATEMENT Approved for public release; distribution unlimited				12b. DISTRIBUTION CODE	
13. ABSTRACT (Maximum 200 words) This study analyzed the processes performed by the Officer Academic Education Repository at the Air Force Institute of Technology at Wright-Patterson Air Force Base, Ohio. Business Process Re-engineering (BPR) methodology was used to define the existing processes. IDEF0 (Integrated Computer Aided Manufacturing Definition Language) and Activity Based Costing techniques were used to map the flow of activities and to determine the costs for handling one education record. The cost for processing one education record averaged approximately \$69.95. Under BPR, the functional expert team evaluates the existing processes to determine which processes are value-added and which are non-value added and generate "to-be", or improved process model. The original intentions of this study were to comply with traditional BPR methodologies to develop the "to-be" model, however this did not occur due to various factors. The thesis team developed the "to-be" model and received validation from one of the functional team members. Because of the difficulties encountered by the thesis team in developing the "to-be" model, the conclusions presented include a section on "lessons learned" to assist future BPR efforts.					
14. SUBJECT TERMS Business Process Reengineering, Activity Based Costing, Records Management, IDEF0 Modeling, Activity Modeling				15. NUMBER OF PAGES 136	
				16. PRICE CODE	
17. SECURITY CLASSIFICATION OF REPORT Unclassified		18. SECURITY CLASSIFICATION OF THIS PAGE Unclassified		19. SECURITY CLASSIFICATION OF ABSTRACT Unclassified	
				20. LIMITATION OF ABSTRACT UL	