

1



US Army Corps
of Engineers

DREDGING RESEARCH PROGRAM

MISCELLANEOUS PAPER DRP-94-2

CONTROLLED TESTS OF EDUCTORS AND SUBMERSIBLE PUMPS

AD-A285 387



by

James E. Clausner, Peter J. Neilans,
Timothy L. Welp, Darryl D. Bishop

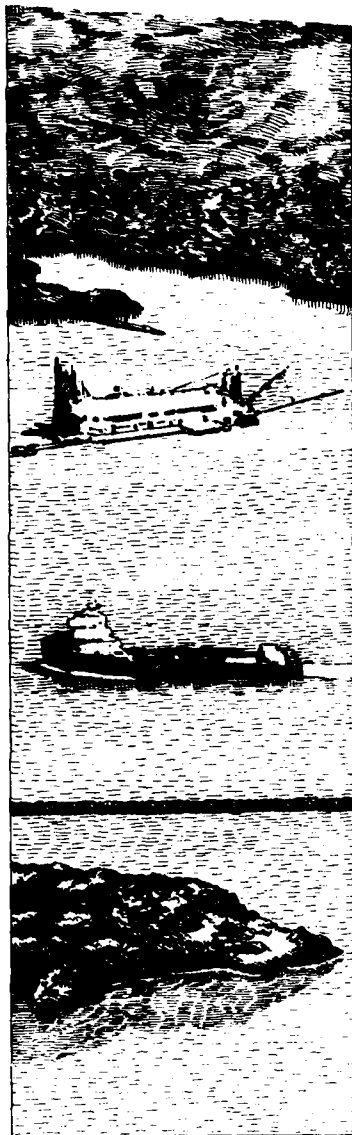

DATE OF PUBLICATION: 1994



September 1994

Final Report

Approved for Public Release; Distribution is Unlimited

13578

94-32001



Prepared for DEPARTMENT OF THE ARMY
U.S. Army Corps of Engineers
Washington, DC 20314-1000
Under Work Unit 32474



The Dredging Research Program (DRP) is a seven-year program of the U.S. Army Corps of Engineers. DRP research is managed in these five technical areas:

- Area 1 - Analysis of Dredged Material Placed in Open Water**
- Area 2 - Material Properties Related to Navigation and Dredging**
- Area 3 - Dredge Plant Equipment and Systems Processes**
- Area 4 - Vessel Positioning, Survey Controls, and Dredge Monitoring Systems**
- Area 5 - Management of Dredging Projects**

The contents of this report are not to be used for advertising, publication, or promotional purposes. Citation of trade names does not constitute an official endorsement or approval of the use of such commercial products.



PRINTED ON RECYCLED PAPER



US Army Corps
of Engineers
Waterways Experiment
Station

Dredging Research Program Report Summary



Controlled Tests of Eductors and Submersible Pumps, MP DRP-94-2

ISSUE: The effectiveness of eductor (jet pump) fixed-plant bypassing systems is often reduced by the presence of debris which reduces the system production rate. Debris can also make the installation and recovery of eductors more difficult. Eductor improvements that increase production in various types of debris and make installation and removal more easily accomplished are desirable.

RESEARCH: A DRP-developed eductor with several features to improve debris resistance was tested in clean sand and a variety of debris combinations to determine production rates. As a comparison, a commercially available eductor with similar hydraulics was also tested. Pull-out forces on the DRP eductor were measured.

Submersible pumps can be alternatives to eductors for sand-bypassing projects. Two commercial eductors, a Toyo Model DP 150B and an H&H PF50x8 were also tested under the same conditions as the eductors.

SUMMARY: In clean sand, both eductors had similar performance, bypassing nearly 400 cu yd/hr. Debris reduced performance of both eductors, but the DRP eductor had improved performance in rock and swim fin/garbage bag debris, while the commercial

eductor had improved performance in wood debris.

Pullout forces on the shrouded DRP eductor stayed low, less than 20,000 lb, when the unit was backflushed for a sufficient period to allow excess water to lubricate the entire outer surface of the eductor.

The larger, more expensive Toyo Pump had the highest production of any unit tested, while the smaller, lighter H&H Pump had the least amount of production. Both submersible pumps required regular operator adjustment of pump elevation to maintain good production and avoid plugging the discharge line. However, both submersible pumps plugged the discharge at least once. The eductors required relatively little operator adjustment and never plugged the discharge line.

AVAILABILITY OF REPORT: The report is available through the Interlibrary Loan Service from the U.S. Army Engineer Waterways Experiment Station (WES) Library, telephone number (601) 634-2355. National Technical Information Service report numbers may be requested from WES Librarians. To purchase a copy of the report, call NTIS at (703) 487-4780.

About the Authors: Messrs. James E. Clausner, Peter J. Neilans, Timothy L. Welp, and Darryl D. Bishop are all members of the WES Coastal Engineering Research Center.

Point of Contact: Mr. James E. Clausner, Principal Investigator for this work unit. For further information about the DRP, contact Mr. E. Clark McNair, Jr., Manager, Dredging Research Program at (601) 634-2020.

Controlled Tests of Eductors and Submersible Pumps

by James E. Clausner, Peter J. Neilans, Timothy L. Welp, Darryl D. Bishop

U.S. Army Engineer Waterways Experiment Station
3909 Halls Ferry Road, Vicksburg, MS 39180-6199

Accession For	
NTIS CRA&I	<input checked="" type="checkbox"/>
DTIC TAB	<input checked="" type="checkbox"/>
Unannounced	<input type="checkbox"/>
Justification
By	
Distribution :	
Availability Codes	
Dist	Avail and/or Special
A-1	

Final report

Approved for public release; distribution is unlimited

Prepared for U.S. Army Corps of Engineers
Washington, DC 20314-1000

Under Work Unit 32474



**US Army Corps
of Engineers**
Waterways Experiment
Station

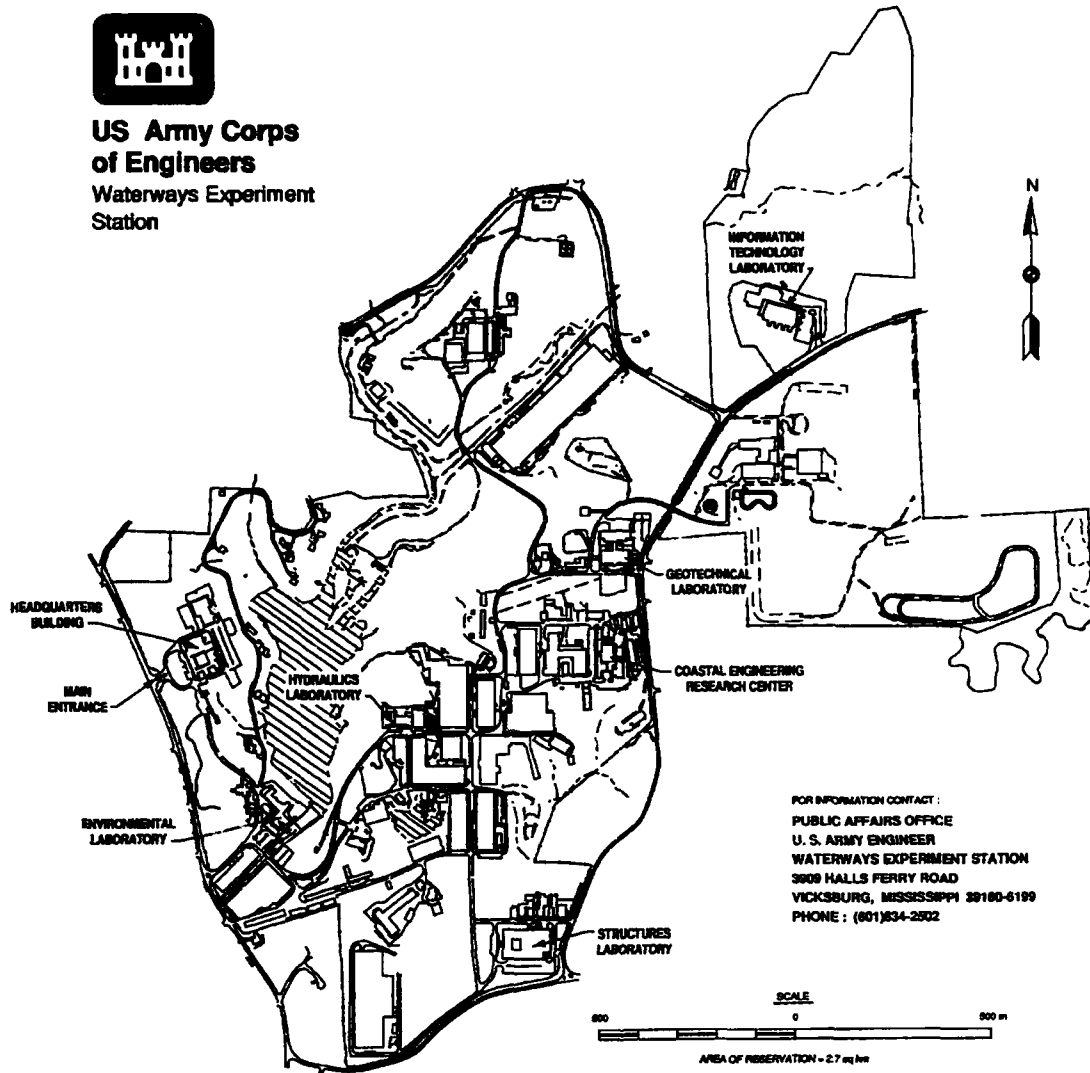

FOR INFORMATION CONTACT :
PUBLIC AFFAIRS OFFICE
U. S. ARMY ENGINEER
WATERWAYS EXPERIMENT STATION
3809 HALLS FERRY ROAD
VICKSBURG, MISSISSIPPI 39180-6199
PHONE : (601)834-2502

Waterways Experiment Station Cataloging-in-Publication Data

Controlled tests of ejectors and submersible pumps / by James E. Clausner ... [et al.] ; prepared for U.S. Army Corps of Engineers.

133 p. : ill. ; 28 cm. — (Miscellaneous paper ; DRP-94-2)

Includes bibliographic references.

1. Ejector pumps — Testing. 2. Jet pumps — Testing. 3. Submersible pumps — Testing. I. Clausner, James E. II. United States. Army. Corps of Engineers. III. U.S. Army Engineer Waterways Experiment Station. IV. Dredging Research Program. V. Series: Miscellaneous paper (U.S. Army Engineer Waterways Experiment Station) ; DRP-94-2. TA7 W34m no.DRP-94-2

Contents

Preface	viii
Conversion Factors, Non-SI to SI Units of Measurement	x
Summary	xi
1—Introduction	1
Background	1
Eductors	3
DRP Eductor Development	4
Submersible Pumps	7
2—Testing Objectives, Location, Equipment, and Procedures	12
Objectives	12
Test Location, Equipment, and Layout	12
Test Procedures	15
Debris Combinations Selected	18
3—Results and Discussion	20
DRP Eductor Deployment and Retrieval Tests	20
Eductor and Submersible Pump Comparison Tests	22
Using Differential Pressure to Measure Specific Gravity	32
4—Conclusions and Recommendations	34
References	36
Appendix A: Submersible Pump Characteristics	A1
Appendix B: Graphical Results from All Tests	B1

SF 298

List of Figures

Figure 1. Eductor	3
-----------------------------	---

Figure 2.	Single pipe, side suction eductor	4
Figure 3.	Eductor with shroud used at Nerang River Entrance, Queensland, Australia	4
Figure 4.	Debris removed from a single eductor crater at the Nerang River Bypass Plant, Queensland, Australia	5
Figure 5.	DRP eductor	6
Figure 6.	Indian River Inlet eductor	6
Figure 7.	Submersible pump with jetting ring	7
Figure 8.	H&H PF50 × 8P submersible pump	9
Figure 9.	Toyo DP150B submersible pump	10
Figure 10.	Toyo DP150B submersible pump agitator	10
Figure 11.	Test site configuration	13
Figure 12.	Control trailer	13
Figure 13.	Processing plant	14
Figure 13a.	Sample test data collected by the computer	16
Figure 14.	Pull-out test of DRP eductor	20
Figure 15.	One-minute average production rates for the DRP and Indian River Inlet eductors	26
Figure 16.	One-minute average production rates for the two eductors with garbage bag and swim fins in the crater	27
Figure 17.	One-minute average production rates for the two submersible pumps in clean sand	28
Figure 18.	One-minute average production rates for the two submersible pumps with garbage bags and swim fins in the crater	30
Figure 19.	Percent solids by weight for one test of each pump in clean sand	31
Figure 20.	Equipment locations for the differential pressure equipment	33
Figure 21.	Comparison of specific gravity of the slurry as measured by the nuclear density meter and differential pressure	33

List of Tables

Table 1.	Eductors and Submersible Pumps Tested	11
----------	---	----

Table 2.	Water Pumps Used During Tests	14
Table 3.	DRP Eductor Pullout Test Summary	21
Table 4.	Tests Conducted	22
Table 5.	Test Results Summary	25

Preface

The study was authorized as part of the Dredging Research Program (DRP) of Headquarters, U.S. Army Corps of Engineers (HQUSACE), and performed under Work Unit 32474, Improved Eductors for Sand Bypassing, which is part of Technical Area 3, Dredge Plant Equipment and Systems Processes. The HQUSACE Chief Advisor for the DRP was Mr. Robert Campbell. Mr. Gerald Greener was HQUSACE Advisor for DRP Technical Area 3 (TA3), which included work unit 32474. Mr. E. Clark McNair, Jr., Coastal Engineering Research Center (CERC), U.S. Army Engineer Waterways Experiment Station (WES), was DRP Program Manager (PM), and Dr. Lyndell Z. Hales, CERC, was Assistant PM. Mr. William D. Martin, Chief, Estuarine Engineering Branch, Estuaries Division, Hydraulics Laboratory, was the Technical Manager of TA3 during the conduct of the study.

This study was performed and the report prepared over the period July 1991 to January 1994 by Messrs. James E. Clausner, Peter J. Neilans, Timothy L. Welp, and Darryl D. Bishop, CERC. Messrs. Clausner and Neilans were under the administrative supervision of Dr. Yen-his Chu, Chief, Engineering Applications Unit, Coastal Structures and Evaluation Branch, Engineering Development Division, CERC. Mr. Welp was under the administrative supervision of Mr. William L. Preslan, Chief Prototype Measurements and Analysis Branch, Engineering Development Division, CERC. Mr. Darryl Bishop was under the administrative supervision of Ms. Joan Pope, Chief, Coastal Structures and Evaluation Branch, CERC. Mr. Thomas W. Richardson was the Chief, Engineering Development Division, CERC. Dr. James R. Houston, was Director, CERC; Mr. Charles C. Calhoun, Jr., was Assistant Director, CERC.

The authors wish to thank the commercial participants. While both submersible pump companies were paid for their efforts, they were also very cooperative and worked hard to accommodate our testing requirements and tight schedule. The H&H Pump company representatives were Mr. Ricky Pollan and Mr. Troy Redwine. The Toyo Pump representative was Mr. R. J. Jukes; Mr. Leslie Cross of Javeler Construction Company provided the Toyo Pump used in the test.

Also greatly appreciated is the support provided by the State of Delaware's Department of Natural Resources and Environmental Control (DNREC) personnel: Mr. John Hughes, Mr. Robert Henry, and especially Mr. Kenneth Melson who came to the site and made a number of good suggestions on equipment and operating procedures. The DNREC also provided the Indian River Inlet eductor and several hundred feet of HDPE pipe for the tests at no cost.

The authors wish to acknowledge the excellent support provided by Dr. Barry McCleave and Mr. Monroe (Joe) Savage of the Instrumentation Services Division of WES. The efforts of the San Diego Parks and Recreation Department in supplying the kelp are also appreciated.

The authors also wish to acknowledge the good work done by the contractor, Standard Gravel Company, headed by Mr. Johnny Green. In particular those who worked long and hard to make these tests a success were Standard Gravel Company's operating crew on this project: Messrs. Lester Spears, Everett Sylvest, and Wayne Thomas.

This report was considerably improved thanks to a thorough review by Messrs. Michael Alexander and Thomas Richardson.

Dr. Robert W. Whalin was Director of WES at the time of publication of this report. COL Bruce K. Howard, EN, was Commander.

The contents of this report are not to be used for advertising, publication, or promotional purposes. Citation of trade names does not constitute an official endorsement or approval of the use of such commercial products.

Conversion Factors, Non-SI to SI Units of Measurement

Non-SI units of measurement used in this report can be converted to SI units as follows:

Multiply	By	To Obtain
cubic yards	0.7645549	cubic meters
feet	0.3048	meters
gallons (U.S. liquid)	3.785412	liters
inches	0.0254	meters
pounds (mass)	453.5924	grams
square inches	6.4516	millimeters
tons (2,000 pounds mass)	707.1847	kilograms

Summary

Eductors have been used as the sand removal device for bypass systems for two decades. The effectiveness of eductor (jet pump) fixed-plant bypassing systems is often reduced by the presence of debris which reduces the system's production rate. Debris can also make the installation and recovery of eductors more difficult. Eductor improvements that increase production in various types of debris and make installation and removal more easily accomplished are desirable.

This report describes a DRP-developed eductor with several features to improve debris resistance (grates, fluidizers) and the results of tests conducted to measure production. The DRP eductor was tested in clean sand and a variety of debris combinations to determine production rates. As a comparison, a commercially available eductor now used at the Indian River Inlet, Delaware, bypass plant, that has hydraulics was also tested. Pullout forces on the DRP eductor were measured. Submersible pumps can be used as alternatives to eductors for sand-bypassing projects. Two commercial eductors, a Toyo Model DP 150B and an H&H PF50x8 were also tested under the same conditions as the eductors.

In clean sand, both eductors had similar performance, bypassing nearly 400 cu yd/hr. Debris reduced performance of both eductors, but the DRP eductor had improved performance in rock and swim fin/garbage bag debris while the commercial eductor had improved performance in wood debris.

Pullout forces on the shrouded DRP eductor stayed low, less than 20,000 lb, when the unit was backflushed for a sufficient period to allow excess water to lubricate the entire outer surface of the eductor.

The larger, more expensive Toyo Pump had the highest production of any unit tested, while the smaller, lighter H&H Pump had the least amount of production. Both submersible pumps required regular operator adjustment of pump elevation to maintain good production and avoid plugging the discharge line. However, both submersible pumps plugged the discharge line at least once. The eductors required relatively little operator adjustment and never plugged the discharge line, in fact, eductor hydraulics make it almost impossible to plug discharge lines.

The immunity of eductors to discharge plugging and the low amount of operator adjustment required continue make them good candidates for fixed-plant sand-bypass systems. Resistance to debris can be improved by selecting the proper combination of grates, fluidizers, etc. Submersible pumps also have application to sand-bypassing projects, but the amount of operator attention required makes them somewhat better-suited to smaller aperiodic applications.

1 Introduction

Background

Interruptions in the shoreline (e.g. inlets and harbors), particularly those with stabilizing structures such as jetties, trap sand moving along-shore. Sand trapped in entrance channels often makes navigation difficult. Sand trapping in accretion fillets, and interior and exterior shoals, frequently causes downdrift beach erosion. Artificial sand bypassing (referred to as bypassing in the remainder of this report) is the transfer of trapped sand across inlets and harbors to assist in maintaining navigable entrances and prevent downdrift beach erosion.

While the majority of sand bypassing is done with conventional dredges (USACE 1991), fixed bypass plants have been used since the 1930's (Jones and Mehta 1980). These early fixed-bypass plants used conventional dredge pumps operating through a suction snout from a pivoting turret attached to the updrift jetty (Watts 1962). In the 1970's the U.S. Army Engineer Waterways Experiment Station (WES) investigated the use of eductors (aka jet pumps) for sand bypassing (McNair 1976), culminating in an instruction report on eductor bypass-system design (Richardson and McNair 1981). During the late 1970's and the 1980's a limited number of U.S. eductor-based bypass plants operated on the East and Gulf Coasts. However, debris often reduced production rate and difficulties in deploying and retrieving the eductors limited effectiveness.

In 1986 a large bypass plant was constructed at the Nerang River entrance in Southport, Queensland, Australia (Clausner 1988). This plant uses 10 eductors spaced at 100-ft intervals along a pier extending through the surf zone and has effectively bypassed large quantities of sand (in excess of 500,000 cu yd/year).¹ However, even in this innovative plant, the operators experienced significant debris problems which often exacerbated difficulties retrieving the eductors.

¹ A table of factors for converting non-SI units of measurement to SI units is presented on page x.

In 1988, the United States Army Corps of Engineers (Corps) started the Dredging Research Program (DRP), a seven year multi-million dollar research effort aimed at saving federal dredging dollars. Partially successful U.S. eductor bypassing efforts, along with the success and problems at the Nerang River Entrance Bypass Project, lead to the creation of the "Improved Eductors for Sand Bypassing" Work Unit as part of the DRP. The goals of the work unit were to design an eductor (referred to as the DRP eductor for the remainder of the report) that maintained good performance in various types of debris and was also more easily deployed and retrieved when used as part of a fixed-bypass plant.

In 1990, the U.S. Army Engineer District, Philadelphia (CENAP) and the State of Delaware completed a cost-shared sand bypass plant at Indian River Inlet (IRI), Delaware (Clausner et al. 1991). This plant uses a single eductor deployed from a crawler crane to mine the updrift fillet. Between the start of bypassing in February 1990 and the controlled tests described in this report (July - August 1991), the plant bypassed over 200,000 cu yd and successfully performed its mission of protecting the bridge approach north of the inlet from undermining due to beach erosion. The eductor used at the IRI bypass plant was designed and manufactured by Genflo America and has nearly identical nozzle, mixer, and diffuser dimensions as the DRP eductor. As such, it provided an excellent baseline for evaluating improvements made in the DRP eductor. The CENAP and the State of Delaware graciously consented to providing their eductor for these tests.

As DRP research on eductors proceeded, it became obvious that submersible pumps should also be considered as an alternative to eductors for the active sand removal portion of fixed-bypassing systems (Clausner 1990). Submersible pumps are relatively small, lightweight centrifugal pumps that are placed directly in the material to be removed. They are described in more detail later in the report. It was decided to include submersible pumps in the tests to allow a direct comparison of performance under essentially identical conditions.

This report summarizes a series of full scale tests of the DRP eductor, the Genflo Eductor used at IRI, and two commercial submersible pumps conducted at the Standard Gravel Company's gravel pit in Enon, LA, during July and August 1991. Included in the report are a description of the eductor concept, a brief history of eductor research conducted by the Corps, descriptions of the DRP and Indian River Inlet Eductors, and a general description of submersible pumps and the Toyo and H&H Submersible Pumps used in the tests. Also included are descriptions of the site, test equipment, material, and procedures used to evaluate the performance of the eductors and submersible pumps in clean sand and a variety of debris types. Finally, results of the tests are presented along with conclusions and recommendations.

Eductors

Eductors are hydraulic pumps with no moving parts (Figure 1). They operate by using a supply (motive) water pump to provide high pressure flow at the eductor nozzle. As the jet contacts the surrounding fluid, momentum is exchanged in the mixer as the jet slows while it accelerates the surrounding fluid, entraining additional fluid into the jet. As the surrounding fluid is entrained by the jet, it pulls in additional fluid from outside the eductor. Placing an operating eductor in saturated sand allows it to bypass a sand/water slurry. Often some of the supply water is diverted to fluidizing nozzles to increase the flow of sand to the eductor. In the diffuser, the excess jet velocity is converted back into sufficient fluid pressure to allow system operation with appropriate hydraulic conditions.

One advantage of eductors over conventional centrifugal pumps is that they are essentially immune to causing blockages in the discharge line. A brief explanation is that as the discharge line starts to clog, the pressure against which the eductor is working increases. This reduces the amount of material the eductor is entraining, thus reducing the potential for clogging the pipe. This is true even when the eductor is used in a hybrid combination with a centrifugal pump. A more detailed description of this phenomenon is given by Wakefield (1992).

WES investigations in the 1970's were based on a commercially available eductor with a single, side suction tube (Figure 2). This type eductor is susceptible to clogging of the side suction duct by debris. The Genflo eductors used at the Nerang River Entrance and at IRI bypass plant have an open annular suction, providing less opportunity for a single small piece of debris to clog the unit (Figure 1). A shroud is added (Figure 3) to reduce the risk of a hemispherical sand bridge forming around the entrainment zone and to reduce the risk of sand feeding back into the eductor nozzle when the eductor is turned off. However, the open annular suction eductor proved to be susceptible to debris, particularly sticks and logs, which could form a filter layer above the eductor. This tangle of sticks (Figure 4) both reduced performance and made retrieval difficult at the Nerang Bypass Plant.

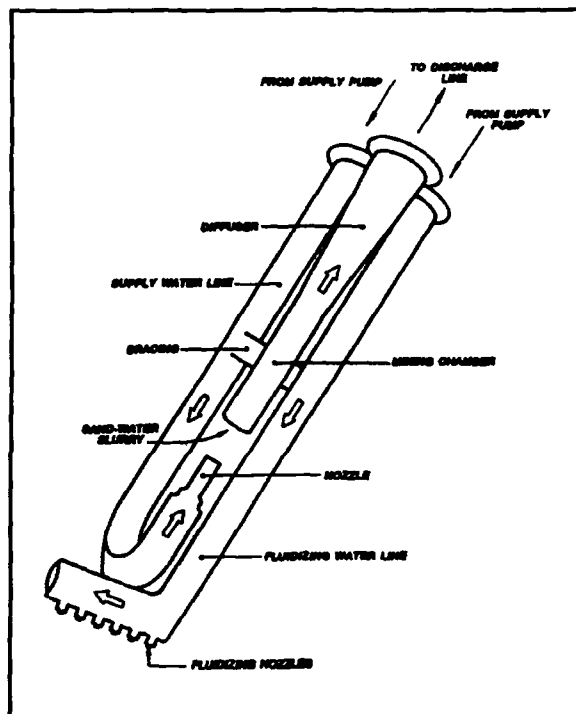

Figure 1. Eductor

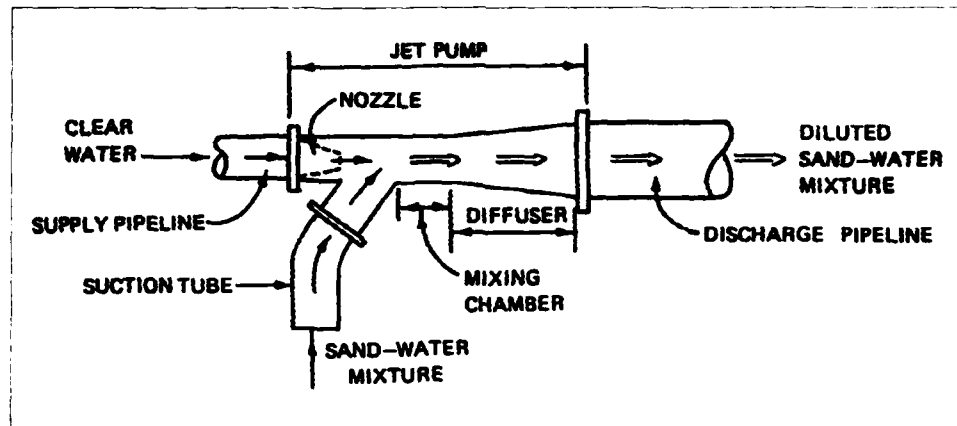

Figure 2. Single pipe, side suction eductor



Figure 3. Eductor with shroud used at Nerang River Entrance, Queensland, Australia

The standard method of handling debris at a plant with fixed eductors (i.e. eductors that are not readily removed) is to backflush, blocking the discharge line, thus forcing the supply water out through suction duct and, hopefully, also flushing out the debris. However, in areas with considerable amounts of debris, the backflushing requirement can become so frequent that it becomes impractical. Therefore, the ability to operate effectively in areas with debris is important and was the driving force behind the DRP eductor development.

DRP Eductor Development

The DRP eductor developed under this work unit was designed to reduce the impact of debris and deployment problems described in the previous section. A number of mechanical and hydraulic devices were considered to solve the problems mentioned. The final configuration selected was designed to have the best combination debris resistance, ease of installation, and simplicity of design and operation.

The DRP eductor was developed under contract to Genflo America. Included in the contract were conceptual



Figure 4. Debris removed from a single eductor crater at the Nerang River Bypass Plant, Queensland, Australia

design, detailed design, construction, controlled comparison tests and field tests. This report describes in detail the controlled comparison tests.

Some of the design features of the DRP eductor include (Figure 5):

- a. A smooth cylindrical outer shape to prevent debris (logs and sticks) from jamming in the eductor framework and making retrieval difficult
- b. A series of fluidizing nozzles around the perimeter of the tip to fluidize the sand for removal and to allow heavy debris to sink below the eductors
- c. A grate over the entrance to prevent debris from entering the suction chamber
- d. A ring jet to reduce pullout forces.

The eductor used at IRI was tested to provide a baseline comparison for the DRP eductor because it has the same basic hydraulic components (2-in.-diam nozzle and 6-in. diam mixer) as the DRP eductor. This eductor, also built by Genflo America, has a simple annular suction duct and a linear manifold of fluidizing nozzles (Figure 6).

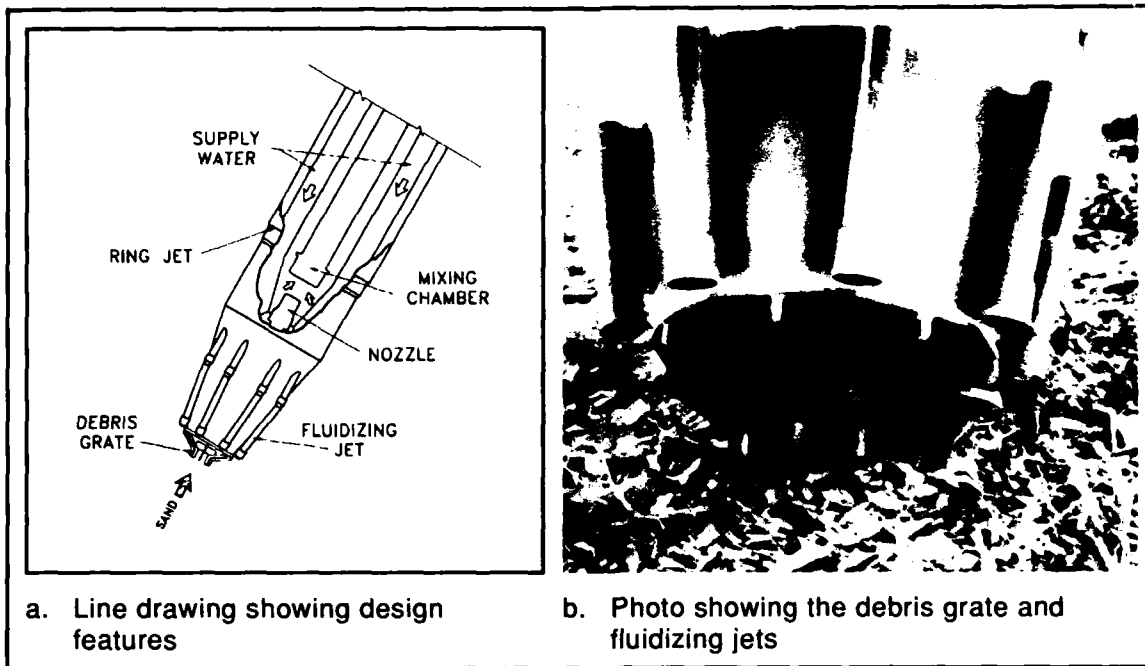

Figure 5. DRP eductor

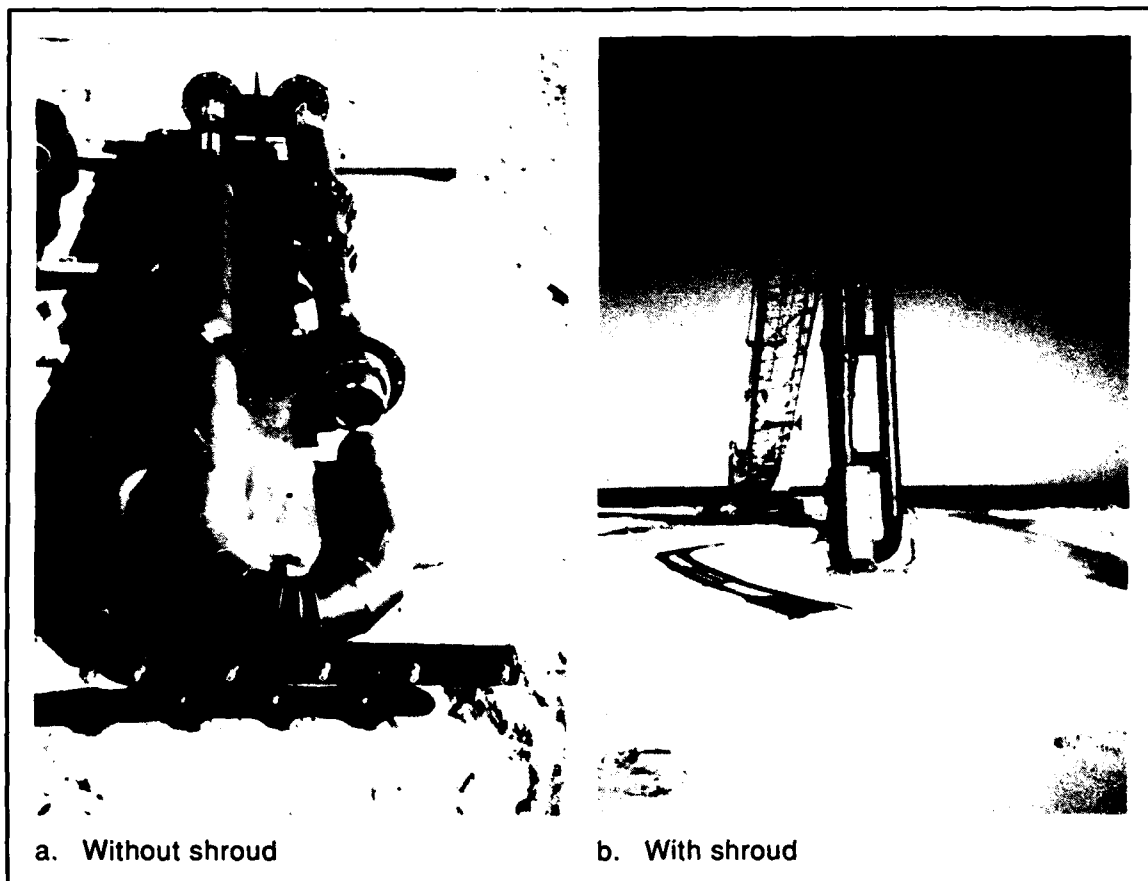

Figure 6. Indian River Inlet eductor

Submersible Pumps

Submersible centrifugal pumps are typically single-stage, vertical pumps, with discharge diameters that range from 4 to 12 in. (Figure 7). Pump sizes are usually based on discharge line diameters. Submersible pumps differ from conventional dredges in that the submersible pump is placed directly in the material to be removed.

Submersible pumps are powered by electrical or hydraulic motors, usually requiring a diesel power source for the hydraulic pump or generator. The power requirements for most of the submersible pumps used in dredging applications are in the 70- to 250-hp range. These pumps can range from a few feet up to 8 ft in height and weigh from under 500 lb to 4 tons. They can be deployed from various platforms such as at the end of a crane or the boom of a backhoe. Obviously, the smaller and lighter the submersible pump, the greater the number of deployment options. Submersible pumps (depending on the deployment method) can be easily maneuvered into areas of limited access.

Submersible pumps operate at a relatively high speed of revolution to produce sufficient pressures and flows. Some submersible pumps have an external agitator on the end of the impeller shaft, which assists in material flow into the pump. In addition, an option to add a jetting ring or small cutterhead to improve material flow to the impeller is available on a number of submersible pumps.

A primary advantage of submersible pumps over eductors is that they do not require a clean water source. In coastal inlet sand-bypassing operations, eductors are often combined with booster pumps to optimize production and efficiency and allow the discharge to be pumped one to several thousands of feet downdrift. Often the supply pump and booster pump are placed in a common pump house adjacent to the inlet which is used as the clean water source. Typically, eductors are placed within 500 to 800 ft of the booster pump due to limited discharge pressures produced by eductors optimized for efficient sand production rate at reasonable pressures. Submersible pumps typically used for bypassing operations often have higher heads than eductors and therefore may not require booster pumps, depending on the distance the material has to be pumped. In the situation where a booster is not needed, the bypassing operation with a submersible pump

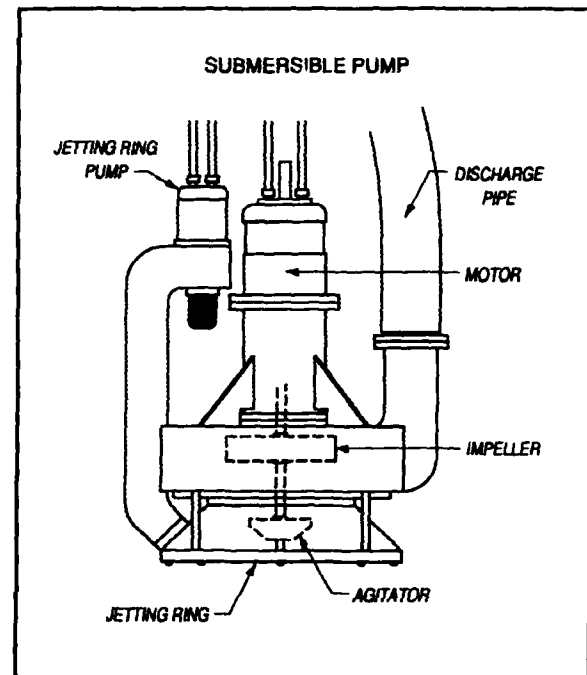

Figure 7. Submersible pump with jetting ring

would consist of the power source, deployment equipment (e.g. a crane), the submersible pump, and discharge pipeline.

An advantage of submersible pumps over conventional hull-mounted dredge pumps is the elimination of the suction line losses (e.g. suction lift and pipe friction) which reduces the potential for cavitation. This advantage is achieved simply by placing the pump directly into the material to be removed.

Some of the major areas of concern for submersible pumps are the life of the pump seals and overall reliability of the mechanical components, motor, and other parts, with much of the concern due to the abrasive nature of the material being pumped. According to manufacturers, this is an area where improvements have been made. Manufacturers recommend checking the pump impellers for wear every 80 hr of operation. For long-term continuous use where it may be difficult to access the pump, manufacturers state that the interval for checking impeller wear can be as long as 300 to 1,000 hr. The electric and hydraulic motors used to power the pumps require overhauls approximately every 2,500 to 7,500 hr.

One disadvantage of submersible pumps is that they tend to dig vertical-sided holes. This operating characteristic can be a particular problem in cohesive material because it makes the pump susceptible to collapse of the hole which can bury and choke the pump and may result in the loss of the unit. Most submersible pumps are not designed for burial and self starting like an eductor, where the water supplied under pressure provides sufficient energy and dilution water to the eductor.

Clean fine sand is the optimum material that submersible pumps can transport. Instantaneous (short-term) effluent solids concentrations from a submersible pump in clean sand can be as high as 60 percent by weight. However, long-term (one to several hours) average solids concentrations would be much lower because the sand will not readily flow to the pump. Instead, the pump must be moved to the material. There is an upper limit of solids concentrations (a function of grain size) that the pump can push through a pipeline without creating the severe risk of plugging the pipeline. In material with any degree of compaction or cohesion, a submersible pump without some type of device to help the material flow (jetting ring or mechanical agitator) could have production as low as 8 to 12 percent solids by weight.

Pumps tested

Two pumps were selected for performance evaluation in the clean sand and debris combinations test series. One pump was a hydraulically powered unit (Model PF 50 × 8 (8-in. discharge)) manufactured by H&H Pump Company and is similar to other very portable, lightweight submersible pumps available for dredging applications (Figure 8). It is also relatively inexpensive, with a 1992 market price of about \$15,000. The H&H

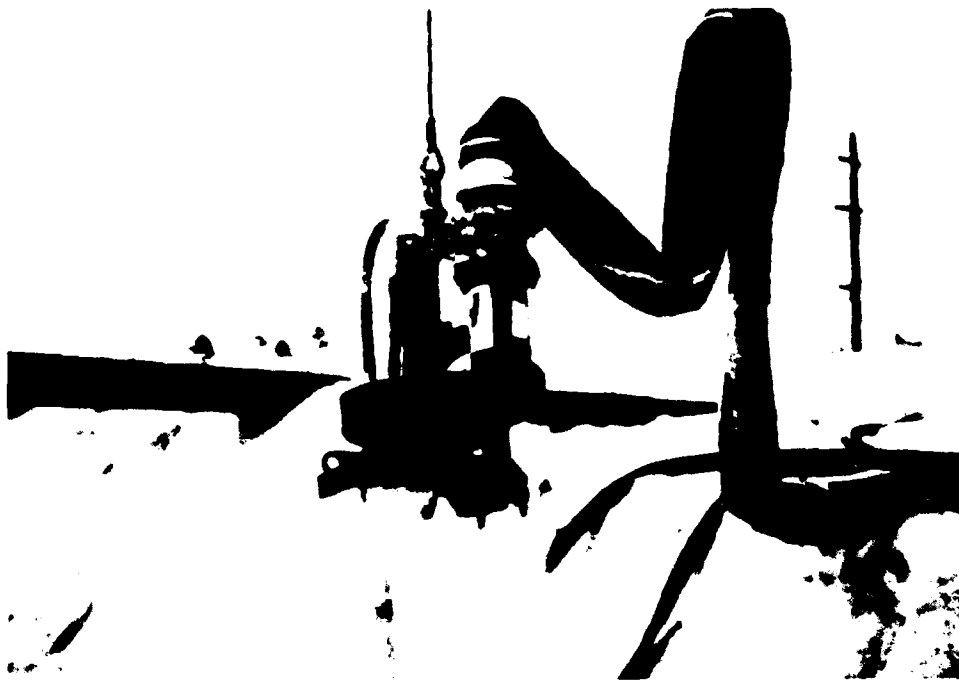

Figure 8. H&H PF50 x 8 P submersible pump (note water jets)

Pump agitator consisted of a jetting ring with 12 water jets. Instrumentation consisted of hydraulic pump pressure gauge along with diesel engine rpm, cooling water temperature, and oil pressure gauges.

The other pump tested was an electrically powered unit manufactured by Toyo, Inc, Model DP-150B (Figure 9). This pump is a much larger, heavier, more expensive unit (market price in 1992 approx \$73,300) designed for continuous use (e.g. mining applications). This pump was equipped with an external mechanical agitator (Figure 10) mounted on the impeller shaft. Pump instrumentation consisted of an ammeter that indicated slurry loading on the electric motor. This reading was monitored and used by the operator as a tool to aid in the unit's placement in the material to optimize the percent solids in the slurry pumped. The physical characteristics for the eductors, submersible pumps, and power sources are presented in Table 1. Additional details on submersible pump characteristics and pump curves are found in Appendix A.

The last column of Table 1 has an estimate of the horsepower required from each power source by each pump during operation. The eductors only require about a 330 hp diesel driven pump for actual operation. The H&H Pump tested is normally supplied with a 150 hp power source; the larger unit used was the only one available at the time of the test. The Toyo Pump requires a high starting horsepower, but only consumes 150-200 hp during operation.

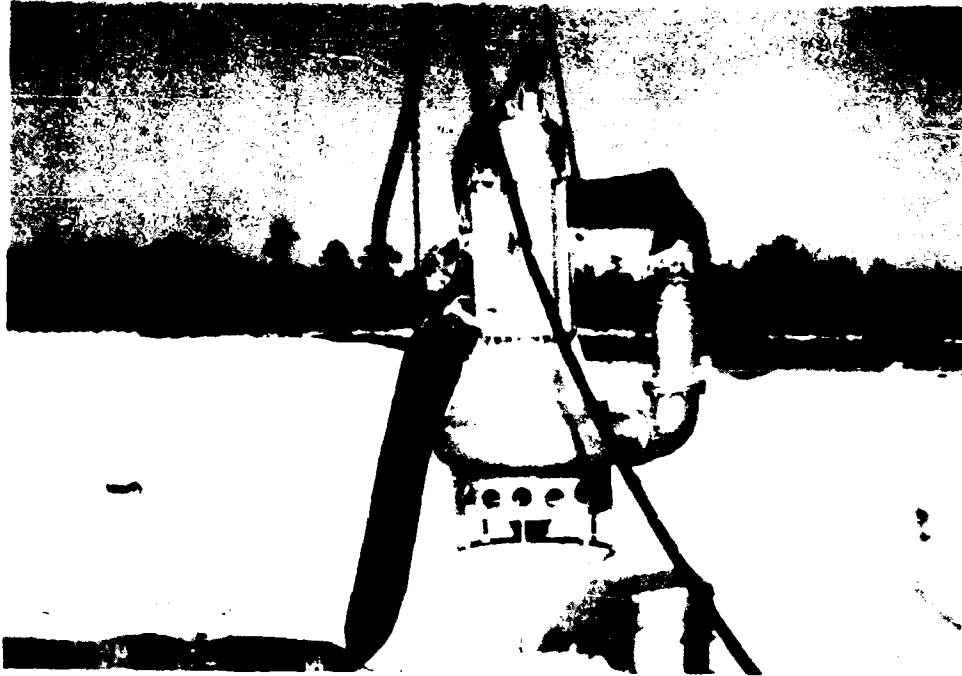

Figure 9. Toyo DP150B submersible pump



Figure 10. Toyo DP150B submersible pump agitator

**Table 1
Eductors and Submersible Pumps Tested**

Item/Manufacturer	Physical Characteristics	Power Source Characteristics	Average Horsepower Consumed
DRP Eductor/Genflo-Standard Gravel Company	20 ft long, 9,000 lb mixer - 6 in. discharge pipe 10 in.	450-hp diesel pump - 3,000 gpm	330 hp
Indian River Inlet Eductor/Genflo Standard Gravel Company	20 ft long, 3,500 lb mixer - 6 in. discharge pipe 10 in.	450-hp diesel pump - 3,300 gpm at 155 psi	150 hp
H&H Model PF 50 x 8 w/20% chrome and nickel inlay liner and jetting ring	3 ft long, 3 ft wide, 724 lb, max spherical solid - 4 in., discharge pipe 8 in.	275-hp diesel/hydraulic pump 75 gpm at 2,000 psi	150 hp
Toyo DP-150B high chrome pump w/external agitator	8 ft long, 3 ft diam, 8,000 lb, max spherical solid, 4.5 in. discharge pipe 10 in.	275-hp diesel generator, 210 kW	150-200 hp

2 Testing Objectives, Location, Equipment, and Procedures

Objectives

The objectives of these tests were to determine the production rate of the DRP eductor under conditions similar to those in a coastal environment. Tests were conducted in clean sand and in a series of different debris combinations similar to those expected on open-ocean coasts. As a baseline, another commercial eductor with nearly identical hydraulics was also tested to show if the DRP eductor modifications to improve debris performance were responsible for the changes in production. Two commercially available submersible pumps were also tested under the same conditions to determine their performance.

Test Location, Equipment and Layout

Tests were conducted at Standard Gravel Company's Enon, Louisiana, gravel pit, where site characteristics were very similar to coastal bypassing locations. The site encompassed an area approximately 300 ft by 450 ft with clean sand (mean diameter 0.3 mm, less than 5 percent fines) in excess of 25 ft thick.

The test site layout was nearly the same for both the eductor and submersible pump tests (Figure 11). A portable, on-site building housed system control instrumentation and monitoring equipment. This "control trailer" was situated between the equipment being tested and the discharge point so there could be visual observation of how each test was progressing (Figure 12). A 30-ft-tall processing plant, an aggregate classification tower with a 1-1/2 in. square grid grizzly (screen), was used to separate debris from the sand (Figure 13). A large crane (110-ton, 100-ft-long boom) was used to deploy the eductors and submersible pumps. A

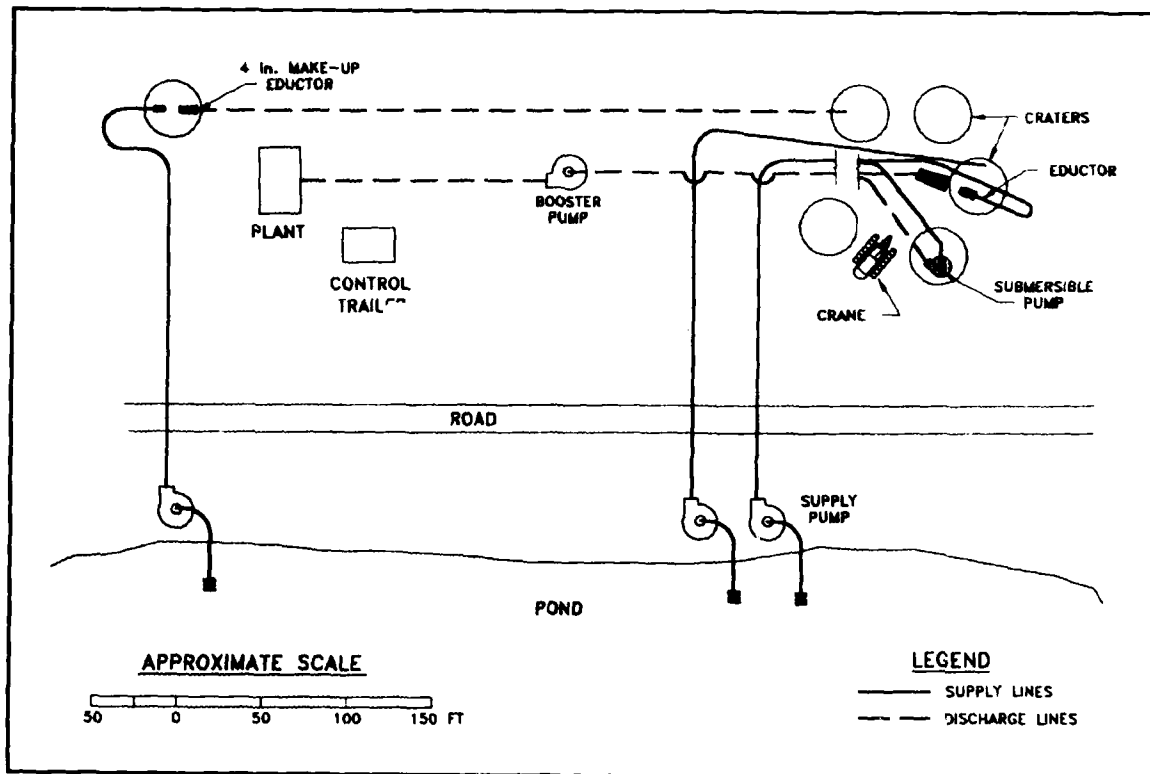

Figure 11. Test site configuration



Figure 12. Control trailer



Figure 13. Processing plant

3-cu-yd backhoe, an 18-ton boom crane, and a bulldozer were also used to move pipe, grade sand, etc.

During the eductor tests, water for the eductors was supplied from an adjacent pond through a 10-in. ID steel pipeline about 250 ft long. Slurry dredged by the eductors and submersible pumps flowed through an 11-in. ID HDPE pipeline to a booster pump, then through a 10-in. steel pipeline to the processing plant. The 30-ft tower minus the 10-ft drop in elevation from the booster pump to the bottom of the tower resulted in a 20-ft vertical lift. Table 2 gives characteristics of the pumps used during the tests.

Table 2 Water Pumps Used During Tests		
Equipment	Horsepower	Flow Rate, gpm
Make-up water to crater	250	3,000
Inline booster	180	3,300
Supply pump for return eductor	180	1,500

Conditions at coastal sites were simulated by saturating the crater test area. This was done by pumping water into the crater before and during tests at a rate sufficient to keep the crater filled with water. To keep the test conditions as repeatable as possible, a 4-inch eductor powered by a separate supply pump was used to recycle the sand separated by the processing plant back to the primary test area. The same few craters were

conveniently used during the clean sand tests. However, during the debris tests, locations of craters from previous tests were determined using survey equipment and were recorded to avoid reuse of a contaminated crater or area.

Instrumentation at the test site included three pressure gauges: one on the discharge side of the supply pump, one at the inlet to the booster pump, and one on the discharge side of the booster pump. A nuclear density meter (measuring slurry specific gravity) was mounted on the vertical section of pipe attached to the processing plant and a doppler flow meter (measuring slurry velocity) was mounted to a horizontal section of pipe near the control trailer. Data from the various gauges and meters were routed through a signal conditioning unit to a personal computer (PC). The PC displayed and recorded pressures, slurry velocity, slurry specific gravity and percent solids by weight, and production (cubic yards per hour). Figure 13a shows a sample of the data collected by the computer during a test.

The hardware and software used to collect the data were originally developed under the DRP Production Meter Technology work unit. For this test, the software was expanded considerably to allow additional data display and more user-friendly operation. WES Instrumentation Services Division developed the software and the signal-conditioning unit and installed the pressure transducers. Overall, the data collection system worked extremely well, with data collected every 10 sec during the tests.

Two video cameras were used during the tests. One camera recorded what occurred in the crater and a second camera recorded the computer screen as a backup in case of failure by the computer to record the test data. No failures of the computer occurred.

Test Procedures

Instruments were calibrated prior to each day's testing. Pressure transducers were calibrated daily using calibration values stored in the computer. The nuclear density meter was allowed to warm-up for 2 hr prior to testing as per manufacturer instructions to insure consistent results. Predetermined supply water and booster pump pressures were established prior to each eductor test to insure that consistent results would be obtained. For the submersible pump tests, only booster pump pressures were predetermined.

Each unit's production capacity for a continuous 30-min performance was tested in "clean" sand and in sand-debris combinations. Three separate trials were conducted for each combination in almost every case. While a larger number of tests for each combination of eductor/pump and debris type would have provided more confidence in the statistical averages, limited funds did not allow additional tests. Three tests for each

This is the first test with the garbage bag combination. 10 garbage bags approximately 58" by 16" (dark colored) and 10 garbage bags approximately 33" by 38" (clear). 4 "swim fins" will be added after the crater is formed.

10 seconds per disk write
 2 seconds per screen update
 10 Channels of Input

DATE	TIME	(1) VELOCITY, FPS	(2) PERCENT SOLID BY WEIGHT	(3) INSTANTANEOUS TRANSPORT RATE, CU YD/HR	(4) SUPPLY PUMP PRESSURE, PSI	(5) JET PUMP PRESSURE, PSI
		(6) SLURRY PUMP PRESSURE, PSI	(7) DIFFERENTIAL PRESSURE, PSI	(8) FLOW 1, FPS	(9) FLOW 2, FPS	(10) TOTAL PRODUCTION, CU YD
7/09/91	13:51:46	13.3908	.4211	2.5512	129.0146	12.2411
		9.9385	.0234	15.0879	8.6147	.0071
7/09/91	13:51:54	13.7625	.4724	2.0629	128.8679	13.0458
		10.6222	.0215	14.8564	8.9048	.0139
7/09/91	13:52:04	13.4860	.4834	.7811	128.8923	12.5338
		10.1583	.0181	14.9414	8.2368	.0185
7/09/91	13:52:14	13.5263	.5640	.7201	128.8190	12.0705
		9.9141	.0156	15.0615	9.0176	.0218
7/09/91	13:52:24	13.9749	.4101	.9642	128.7945	11.9729
		9.4990	.0137	15.0176	9.2856	.0262
7/09/91	13:52:34	13.5318	.5237	.9032	129.2102	12.6557
		9.9385	.0127	15.1348	9.1084	.0295
7/09/91	13:52:44	13.4952	.5713	2.2460	128.9902	12.5581
		10.0606	.0107	15.0469	9.4394	.0367
7/09/91	13:52:54	13.7515	.4101	2.9174	128.8679	12.6801
		10.4269	.0093	15.1040	8.9531	.0454
7/09/91	13:53:04	13.6197	.4248	.3539	128.9413	12.2168
		9.3280	.0083	14.9941	9.2754	.0498

Figure 13a. Sample test data collected by the computer

combination were selected because they allowed a reasonable estimate of average production and provided an opportunity for testing both eductors and submersible pumps in a variety of debris combinations. For a limited number of cases, only two runs were made due to time constraints.

The crane was used to deploy the eductor, or submersible pump, and reposition it as needed during each test. The same crane operator was used for all the tests conducted with different types of pumps and debris combinations to minimize crane operator influence on production results. The debris combinations were laid on clean sand in a random pattern within a radius of approximately 15 feet around the point of application of the pump. As the unit excavated sand, the debris would "fall" into the crater, similar to the manner debris are encountered in sand-bypassing operations.

The eductor tests began by starting the supply and booster pump diesel power units and bringing them up to operating temperature. Then the supply pump was engaged, effectively starting the eductor, followed by engaging the booster pump. Next, the crane operator would lower the eductor into the crater until the eductor tip was at a depth of about 18 ft. By this time the production had usually stabilized and the clock for the 30-min test was started.

For the submersible pump tests, first the submersible pump's diesel-driven power units and the booster pump diesel were started and allowed to reach operating temperatures. Then the submersible pump was lowered into the crater, and the power to the submersible pump was activated, either by starting hydraulic fluid flow to the H&H Pump or engaging the generator on the Toyo Pump. Immediately following this, the booster pump was engaged. Once the submersible pump began to acquire solids at a consistent rate, the 30-min clock was started.

In a fixed-bypass plant, repositioning of eductors is often either difficult or impossible. The typical reaction of an operator to a debris-induced reduced production rate would be to continue operating at a reduced rate until the production was very low or the end of the operating day was reached. Then the operator would backflush to try to clear the debris. When restarting the eductor, the operator would hope that the debris would have moved far enough away that it would not immediately be re-acquired by the eductor. In these tests, stopping to backflush was considered impractical, tests would have to have lasted much longer, greatly reducing the number of tests run. Instead, when the production rate was reduced, the eductor or submersible pump was lifted a few feet then placed back down in the same general area. It was hoped that this would provide some opportunity for the unit to clear itself (perhaps somewhat simulating backflushing), but forced the unit to continue operating in the debris field and, thus, making the tests a reasonably valid simulation of a fixed-plant situation.

During the stone debris tests, it was observed that stones too large to enter the pump would accumulate at the bottom of the crater and form a barrier between the pump and sand, reducing production rates. Repositioning the pump would allow it to excavate sand on the fringes of the consolidated debris barrier and pump slurry at higher rates till the process repeated itself. A video camera recorded the pump in the crater during the trial and documented debris accumulation at various locations (at the grizzly, in the booster pump stone box, or pump suction duct).

Under certain conditions, the submersible pumps acquired slurry at very high percent solids concentrations (sometimes exceeding 60 percent solids by weight). At this point the discharge line was susceptible to being plugged if a slope cave-in temporarily choked the pump or if the pump momentarily lost power. At these times the operator would raise the submersible pump a foot or two to reduce solids concentrations. It was not always possible to give the operator sufficient notice to prevent plugging the line.

At the completion of each test with debris combinations, the crater area would be contaminated by debris that was too large to be transported by the system or that did not come into contact with the pump. Because of this, the contaminated area was surveyed by conventional methods, its position logged, and it was not used again. The flexible plastic HDPE pipe allowed the pumps to be redeployed in uncontaminated areas immediately adjacent to the previous test crater.

Debris Combinations Selected

Based on past experience with eductors, several different combinations of debris were selected. While most types of debris or trash can be found on the bottom in coastal areas, the following basic debris/trash types were selected. Logs and sticks are often found in coastal waters as a result of river transportation. Stones are also common in coastal areas, both from naturally occurring materials (e.g coral), river input, and core stones washed-out or left over from jetty construction. Garbage and ice bags (plastic products) are commonly found in the coastal zone as are more sturdy, but still flexible, items such as swim fins, rubber tires, etc. Aluminum beverage cans are also common in the coastal zone. Finally, kelp is found in the coastal areas of the Pacific. Based on these debris/trash types, the following combinations of materials were selected for testing:

- a. Clean sand with a mean diameter of 0.3 mm and less than 5 percent fines.
- b. Sixteen cubic feet of cut wood that varied in length from 1 to 3 ft and the diameters varying between 1 to 6 in. Prior to the tests, the wood pieces were soaked in water to produce a negative buoyancy which allowed them to sink to the bottom of the crater during the trial.

- c. Sixteen cubic feet of stone riprap ranging in size from 2 to 18 inches with a mean diameter of 7 in.
- d. Sixty garbage-bag-sized plastic liners (weighted with sand) and 15 "swim fins" fabricated from 3/4-in., 4-ply conveyor belt cut into 9-by 24-in. rectangular pieces.
- e. Approximately 500 aluminum beverage cans (punctured to sink) were tested in one eductor trial with no apparent effect on production (small pieces of shredded cans were observed at base of the processing tower) so the use of this debris was discontinued.
- f. Kelp was graciously donated by the San Diego Parks and Recreation Department, but the test runs with this debris were discontinued due to the kelp's increasing rate of deterioration and negligible effect on production rates. Had fresh kelp been available, it likely would have had a measurable impact on production.

One other major type of debris/trash that was considered for testing is rope, both wire rope and synthetic. However, limitations on time and funds and questions on exactly how to deploy it and what type (wire, synthetic) and size to use prevented rope from being tested.

3 Results and Discussion

DRP Eductor Deployment and Retrieval Tests

In addition to the debris tests, the DRP eductor was tested for ease of deployment and retrieval. The deployment tests consisted of measuring the time required to sink the unit to a depth of 18 ft using only the fluidizing jets. By modifying the fluidizing jets so that the rear two jets pointed back toward the deployment frame with the remaining jets pointed straight down, the unit sunk to design depth of 18 to 20 ft in 90 sec or less.

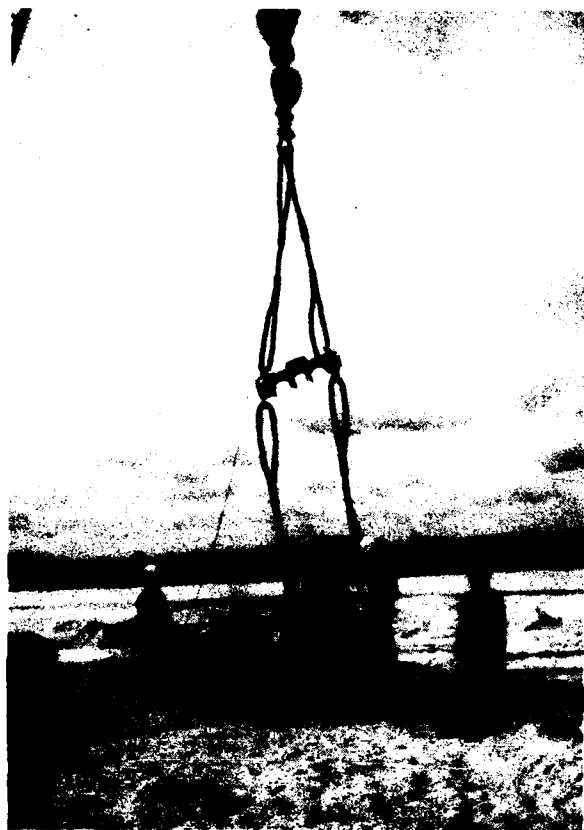

Figure 14. Pull-out test of DRP eductor

During the retrieval tests, the deployment frame was removed, and the eductor sunk vertically into the sand a distance of 18 to 20 ft. Then a series of 17 pull tests were done with the crane acting through an inline load cell (Figure 14). Table 3 summarizes the tests' conditions and results. Variables tested included whether or not the sand was saturated, how long the eductor sat between tests, and the active assistance of two of the hydraulic units - the ring jet, and the eductor itself. For the eductor alone, the discharge line was blocked forcing all the water out the open end of the eductor. Pullout forces required to start the eductor moving ranged from 8,500 to 49,000 lb (the dry weight of the eductor is 7,000 lb). Dry pullout forces with little delay between tests (tests 1-3 and 8) ranged from 16,000 to 20,000 lb. Those tests that only had 15 to 20 min between tests, are labeled as having a "short" time delay.

The highest pullout forces resulted after the sand was allowed to sit for some time, thus becoming more tightly packed around the eductor. Test 12, with saturated sand and a blocked discharge line, sat for 1.5 hr and had a pullout force of 49,000 lb. Test 13, conducted soon after test 12, required 39,000 lb, indicating the sand was still tightly packed around the eductor. For tests 14 and 15, the packed sand had loosened somewhat due to water flowing up around the side of the eductor and resulted in much lower pullout forces, 17,000 and 12,000 lb. The low value for test 15, like test 11, is probably due to performing several tests in a row.

Test Number	Sand Condition/Hydraulic System	Time Delay	Pullout Force, lb
1	Dry	Short	16,000
2	Dry	Short	17,500
3	Dry	Short	17,500
4	Saturated/Ring Jet	Short	16,000
5	Saturated/Ring Jet	Short	19,500
6	Saturated/Ring Jet	Short	19,000
7	Saturated/Ring Jet	Short	20,500
8	Dry	Short	18,000
9	Saturated/Ring Jet	Short	20,000
10	Saturated/Discharge Blocked	Short	16,000
11	Saturated/Discharge Blocked	Short	8,500
12	Saturated/Discharge Blocked	1.5 hr	49,000
13	Saturated/Discharge Blocked	Short	39,000
14	Saturated/Discharge Blocked	Short	17,000
15	Saturated/Discharge Blocked	Short	12,000
16	Dry	1.0 hr	35,000
17	Saturated/Ring Jet 10 min	0.75 hr	19,000

Allowing the sand to sit also increased the pullout forces on the dry sand as evidenced by test 16's pullout force of 35,000 lb. However, operation of the ring jet for 10 min (at which time water could be observed flowing up around the eductor) reduced the pullout load down to 19,000 lb, even after the eductor had been sitting for 45 min.

When used in a fixed location at an actual bypass plant, the eductor would very likely be sitting for a considerable length of time. Here the most important factor for reducing the pullout force is to allow the sand around the whole unit to become fully fluidized, reducing skin friction. This could be accomplished by operating the eductor and blocking the discharge line, and/or using the ring jet. The higher flows achieved by blocking the eductor discharge line (so all the supply water exits the open end of the eductor) should provide the quickest saturation of the sand. However, the ring jet should also be effective. In either case, it is important to allow sufficient time for the sand around the eductor to become fluidized. However, based on these tests, the added cost and complexity needed to include the ring jet do not appear to be justified for reducing pullout forces.

Eductor and Submersible Pump Comparison Tests

A total of 61 tests were run, with 48 of the tests meeting the criteria of 30 min of continuous performance. Table 4 summarizes all the tests run. Several tests were run to confirm that all the pumps, instruments, data logging equipment, etc., were operating properly. Appendix B (Plates B1-B47) provides plots showing test results for each valid test, i.e., tests that meet the 30-min performance criteria. The maximum and average production rates for each set of valid tests are summarized in Table 5. Appendix B (Plates B48-B63) provides plots of production rates for all the valid tests with comparisons of performance between the eductors and submersible pumps for the clean sand and debris combinations.

Table 4 Tests Conducted				
Equipment Tested	Material Tested	Date, yymmdd	Duration, min	Comments
DRP eductor	Clean sand	910702	38	Trial 1
DRP eductor	Water	920702	—	Calibration test
DRP eductor	Clean sand	910702	33	Trial 2
DRP eductor	Clean sand	910702	35	Trial 3
DRP eductor	Water	910703	—	Calibration test
DRP eductor	Cans	910703	45	Trial 1
DRP eductor	Riprap	910709	—	Sank/positioned riprap
DRP eductor	Brick & concrete	910709	30	Trial 1

(Sheet 1 of 3) (Continued)

Table 4 (Continued)				
Equipment Tested	Material Tested	Date, yymmdd	Duration, min	Comments
DRP eductor	Garbage bags & swim fins	910709	36	Trial 1
DRP eductor	Garbage bags & swim fins	910709	33	Trial 2
DRP eductor	Garbage bags & swim fins	910709	33	Trial 3
DRP eductor	Garbage bags & swim fins	910710	35	Trial 4
DRP eductor	Riprap-stone	910710	41	Trial 1
DRP eductor	Riprap-stone	910710	36	Trial 2
DRP eductor	Riprap-stone	910710	30	Trial 3
DRP eductor	—	910715	—	Replaced pressure cell
DRP eductor	Riprap-stone	910715	30	Trial 4
DRP eductor	Sand	910711	32	Only 1 trial
DRP eductor	Wood	910715	30	Trial 2
IRI eductor	Garbage bags	910716	36	Trial 1
IRI eductor	Clean sand	910716	—	Test aborted, kink in hose
IRI eductor	Garbage bags	910718	30	Trial 2
IRI eductor	Garbage bags	910718	30	Trial 3
IRI eductor	Wood	910718	30	Trial 1
IRI eductor	Wood	910718	30	Trial 2
IRI eductor	Wood	910718	30	Trial 3
IRI eductor	Stone	910718	34	Trial 1
IRI eductor	Stone	910719	38	Trial 2
IRI eductor	Stone	910722	31	Trial 3
IRI eductor	Clean sand	910716	33	Trial 2
IRI eductor	Clean sand	910716	30	Trial 3
IRI eductor	Clean sand	910716	31	Trial 4
IRI eductor	Kelp	910722	32	Trial 1
DRP eductor	Wood	910731	56	Trial 3

(Sheet 2 of 3) (Continued)

Table 4 (Concluded)

Equipment Tested	Material Tested	Date, yymmdd	Duration, min	Comments
DRP eductor	Kelp	910724	30	Trial 2
H&H pump	Clean sand	910808	30	Trial 1
H&H pump	Clean sand	910807	30	Trial 2
H&H pump	Clean sand	910807	30	Trial 3
H&H pump	Wood	910815	52	Trial 1
H&H pump	Riprap	910814	43	Trial 1
H&H pump	Riprap	910815	42	Trial 2
H&H pump	Garbage bags	910814	35	Trial 1
H&H pump	Garbage bags	910814	32	Trial 2
H&H Pump	Garbage bags	910814	—	Trial 3; test aborted, line plugged
H&H Pump	Wood	910819	—	3 remaining tests aborted; major pump problems
Toyo Pump	Clean sand, no booster pump	910820	—	Trial 1; test aborted, pump problems
Toyo Pump	Clean sand, no booster pump	910820	—	Trial 2; test aborted, line plugged
Toyo Pump	Clean sand, no booster pump	910820	32	Trial 3
Toyo Pump	Clean sand, no booster pump	910820	35	Trial 4
Toyo Pump	Clean sand w/booster pump	910821	33	Trial 5
Toyo Pump	Garbage bags & swim fins	910821	31	Trial 1
Toyo Pump	Garbage bags & swim fins	910821	30	Trial 2
Toyo Pump	Garbage bags & swim fins	910821	30	Trial 3
Toyo Pump	Wood	910822	30	Trial 1
Toyo Pump	Wood	910822	34	Trial 2
Toyo Pump	Stone	910823	30	Trial 1
Toyo Pump	Stone	910823	31	Trial 2

(Sheet 3 of 3)

**Table 5
Test Results Summary**

Equipment Tested	Debris Type	Production Rates, cu yd/hr			
		Maximum		Average	
		10 sec	1 min	5 min	All ¹
DRP Eductor	Sand	472	461	456	415
	Stone	448	406	400	296
	Garbage bags and swim fins	396	390	351	249
	Wood	410	406	396	316
Indian River Inlet Eductor	Sand	543	535	513	408
	Stone	520	519	494	239
	Garbage bags and swim fins	484	460	442	217
	Wood	507	492	468	379
H&H Submersible Pump	Sand	527	521	391	253
	Stone	479	426	251	97
	Garbage bags and swim fins	415	348	328	215
	Wood	321	214	96	— ²
Toyo Submersible Pump	Sand	751	739	548	444
	Stone	754	720	639	469
	Garbage bags and swim fins	717	673	591	380
	Wood	747	718	668	285

¹ Average of all tests with that type debris and pump meeting the 30 min performance criteria.
² No test met the criteria of 30 min continuous performance.

Eductor tests

The DRP Eductor and the IRI Eductor had very similar performance in clean sand, about 400 cu yards per hour (yd³/hr) (Figure 15). The production is relatively constant throughout each half-hour test period for all tests of both eductors in clean sand, though the first test with the DRP eductor had lower rates which could not be attributed to an obvious cause. These relatively constant production rates are due to the fact that eductors are self-metering. As they pick up more material their ability to pick up additional material is reduced and the reverse is true as they pick up less material. The eductors consistently pumped slurries of 35 to 42 percent solids by weight in clean sand.

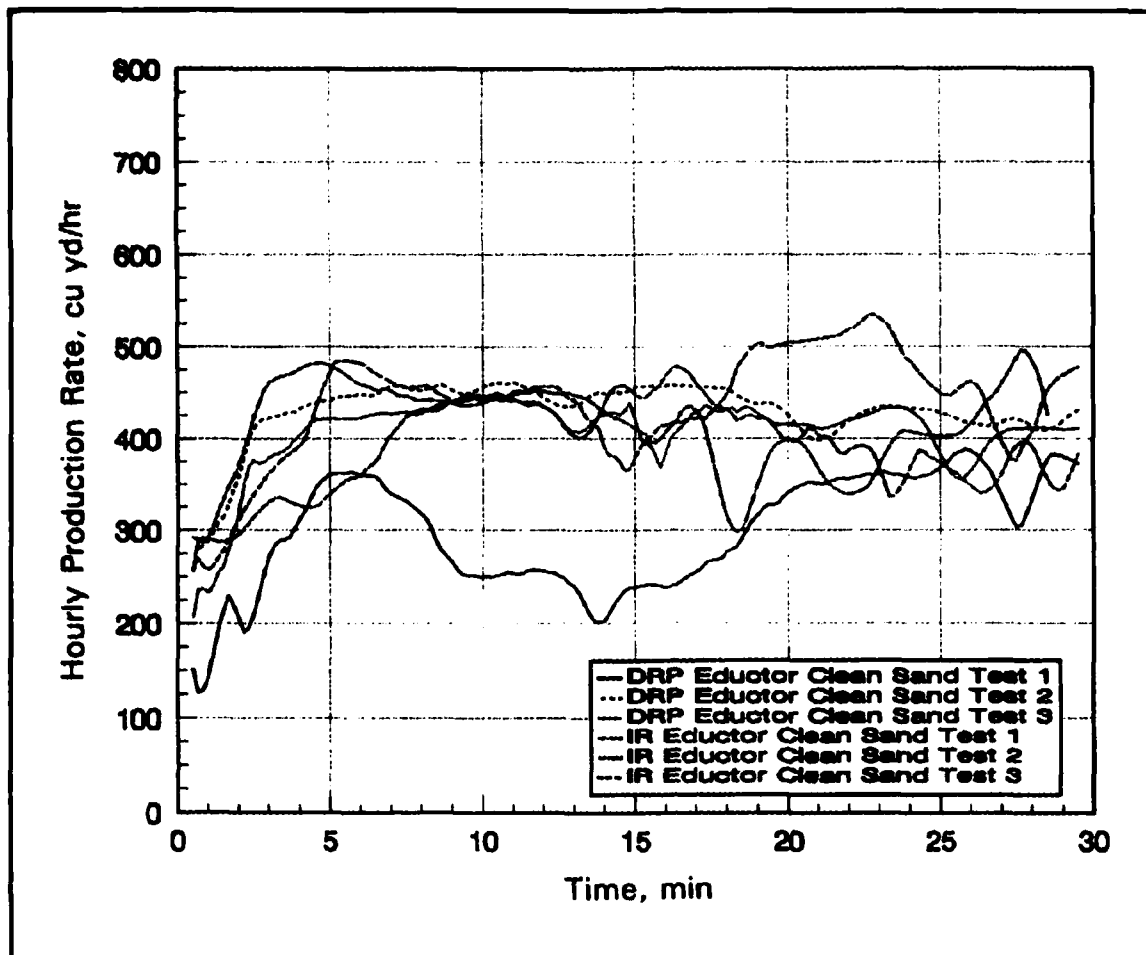

Figure 15. One-minute average production rates for the DRP and Indian River Inlet eductors

As expected, eductor performance was reduced substantially in debris. The DRP eductor was considerably better in stone (296 versus 239 cu yd/hr) and slightly better at bypassing garbage bags and swim fins (249 versus 217 cu yd/hr). The IRI eductor was superior in wood (379 vs 316 cu yd/hr). In the tests with debris, production rates at the beginning of the tests were nearly the same as in clean sand. As the test progressed, debris would accumulate around the eductor at the bottom of the crater causing a reduction in percent solids to below 30 percent, thus reducing production rates. This can be clearly seen in Figure 16 where production drops from rates of 300 to 400 cu yd/hr to rates of only about 100 to 200 cu yd/hr at the end of the 30-min test period. Similar reductions in production rates for the eductors are shown in plots of other tests with debris contained in Appendix B (Plates B48-B63). If the eductors were forced to operate for long periods of time in concentrated debris fields, production would likely have been even lower.

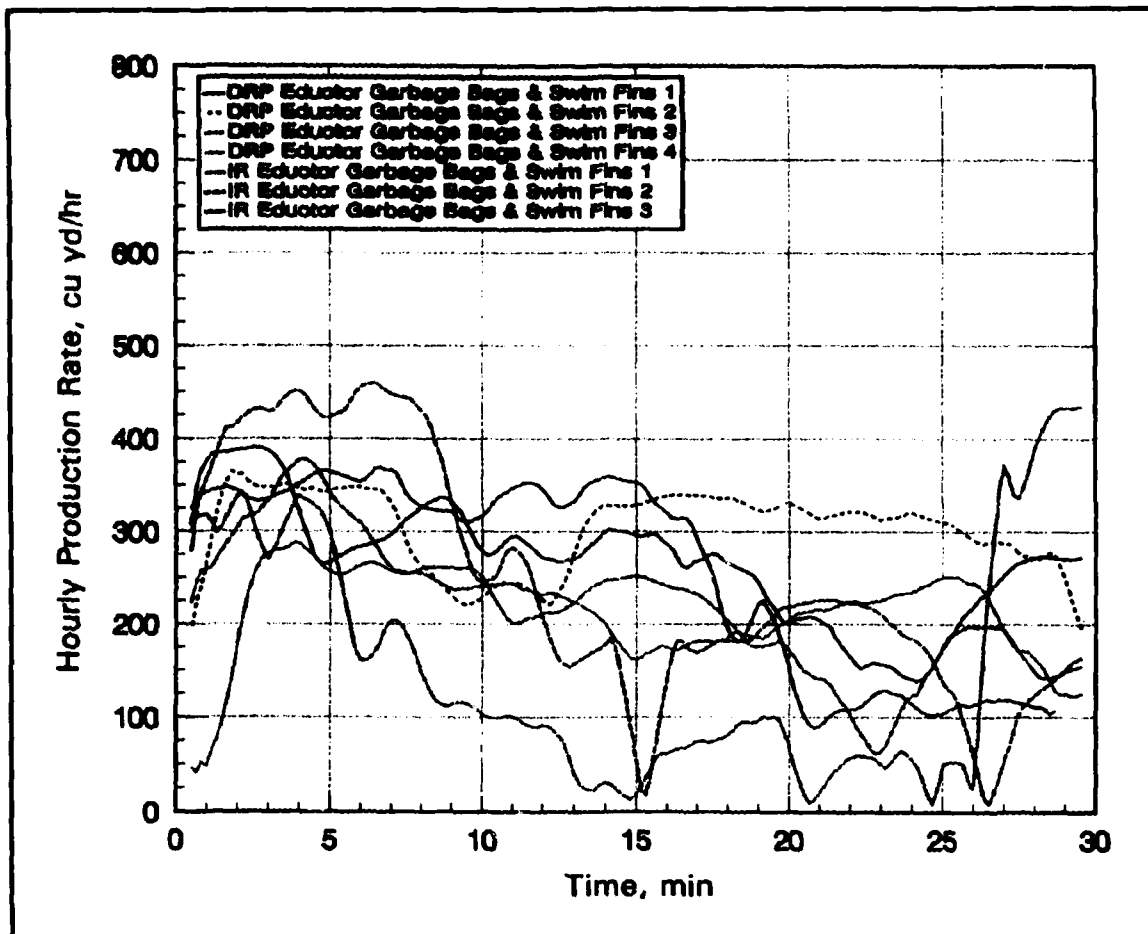

Figure 16. One-minute average production rates for the two eductors with garbage bags and swim fins in the crater

Submersible pump tests

Of the two submersible pumps, the Toyo Pump had consistently higher production in clean sand and all types of debris, while the H&H Pump had the lowest production of any unit tested. Figure 17 is a plot of 1-min average production rates for the two submersible pumps in clean sand. It should be noted that the H&H Pump had only an 8-in. diam discharge pipe, while the eductors and Toyo Pump had 10-in. diam discharge pipes. Had a 10-in. discharge coupling that attached directly to the pump housing been available for the H&H Pump, an increase in production rate of up to 15 percent was possible.¹ This could have potentially raised production rates for the H&H Pump to 292, 112, and 247 cu yd/hr in sand, stone, and garbage bags and swim fins, respectively. The H&H Pump could produce slurries with 60 percent solids for short periods of time, but generally averaged around 30 percent solids in clean sand.

¹ Stovall, H. of H&H Pump Company, Personal communication, 24 January 1992.

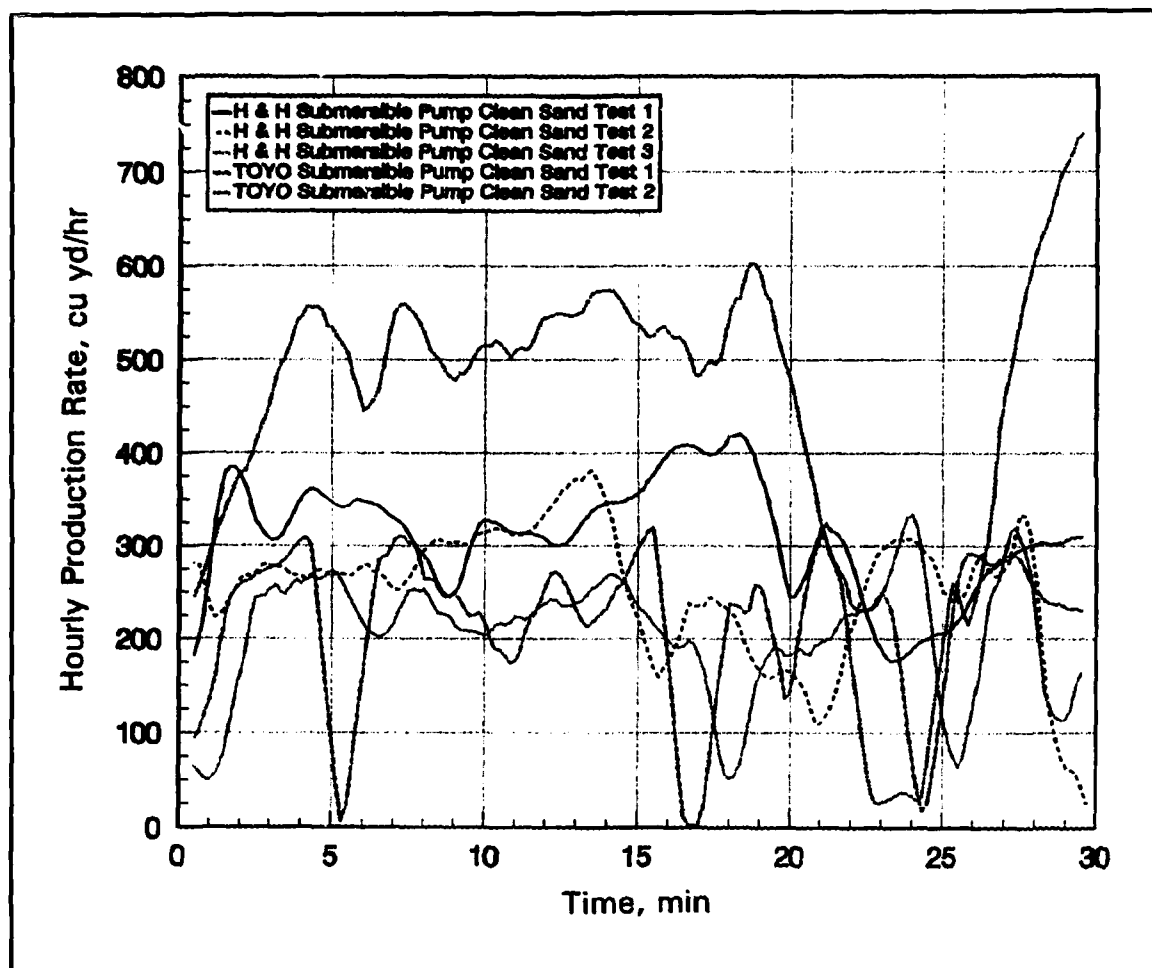

Figure 17. One-minute average production rates for the two submersible pumps in clean sand

The ability to capture very high percent solids made the H&H Pump more prone to plugging of the discharge line than any of the other units tested, with a total of two instances where the line was plugged. A considerable amount of operator attention to raise and lower the H&H Pump was needed to achieve maximum production and still prevent plugging of the discharge line. Part of the line plugging problem was due to the fact that the crane operator could not see the submersible pump instrumentation which was mounted directly on the diesel power unit situated about 100 ft from the crane. The submersible pump operator would first make the decision to raise or lower the unit based on hydraulic pressure and flow readings, and then signal the crane operator to raise or lower the submersible pump. This additional time delay in relaying this information contributed to the line plugging problem.

Initially, the Toyo representatives thought the Toyo Pump could be operated without the booster, thus several tests were run without a booster. However, horsepower limitations caused by the system hydraulics and high percent solids available led the Toyo representatives to start using

the booster. This made results more comparable with the other systems, all of which used the booster pump.

The Toyo Pump had the highest overall production of any unit tested, nearly 500 cu yd/hr, with percent solids often exceeding 45 percent by weight. The improved production in stone versus sand was due to the operator gaining experience with the Toyo Pump during the sand tests which were conducted first. The wood and garbage bags with swim fins had an appreciable impact on production, reducing it to 285 and 380 cu yd/hr, respectively. Like the H&H Submersible Pump, the Toyo Pump was also very sensitive to operator control, with relatively constant raising and lowering of the unit required to maintain high production and prevent plugging of the discharge line. However, unlike the H&H Pump, the amount of load on the pump was nearly instantaneously available to the crane operator. Toyo Pump load is indicated on an ammeter which was on a cable. There was sufficient cable to allow the ammeter to be placed on the crane tracks, in full view of the operator. Thus, when the ammeter read greater than 250 amps, indicating the pump was being excessively loaded, the crane operator could immediately raise the pump, lowering percent solids concentration and reducing the possibility of plugging the discharge line. The 250-amp limit is based on the horsepower capacity of the electric motor powering the Toyo Pump.

The situation that led to plugged lines with the submersible pumps was likely the following. After about 15 to 20 min of operation, the crater had deepened to a point that a side slope failure of the crater would virtually bury the Toyo and H&H Pumps. When this occurred, the submersible pumps would start loading up with high solids concentrations resulting in increased horsepower and head requirements. Both of these situations can be the limiting factors of a pump/pipeline system and can lead to plugged discharge lines. The Toyo Pump appeared to handle these inundation conditions better than the H&H Pump, likely due to a combination of the pump design features and the ability to more quickly display the information to the crane operator.

Probably the prime factor in the increased production and reduced susceptibility to line plugging of the Toyo Pump as compared to the H&H Pump is the combination of the external agitator and perforated shroud that cover the suction inlet (Figure 10). The H&H Pump has an external jetting ring but no protection device over the suction inlet (though one is available). When the H&H Pump was buried due to slope failures as described above, it is possible that jetting ring allowed very high solids concentrations to enter the impeller, causing a mechanical lock up of the impeller with the pump casing or pump shroud. The Toyo Pump's external agitator, combined with the inlet shroud, apparently assists in metering solids into the pump more effectively than the H&H combination and thus contributes to its better performance and reduced risk of line plugging.

The test results for the submersible pumps in debris did not show a trend toward lower production as the test progressed. In several tests the production rate actually increased (see Figure 18). These results, which are contrary to what one would expect, may be due to the crane operator frequently moving the pump to maintain production after learning how to position the pump for maximum production.

Comparing the plots of percent solids by weight as shown in Figure 19, it can be seen that a much more uniform amount of material is acquired by the eductors when compared with the submersible pumps. The rate of production for the eductors is apparently smoothed by their self-metering capability. Conversely, at times when very high concentrations of material are available to the submersible pumps, e.g. immediately after a side slope failure, the submersible pumps will continue to acquire material at very high rates, sometimes resulting in plugging of the discharge line. As a result, the percent solids concentration can vary rapidly, depending on how close the crane operator keeps the submersible pump to the material. An eductor may be placed directly in the material and its self-metering feature will prevent it from acquiring material at too high a rate. Discharge

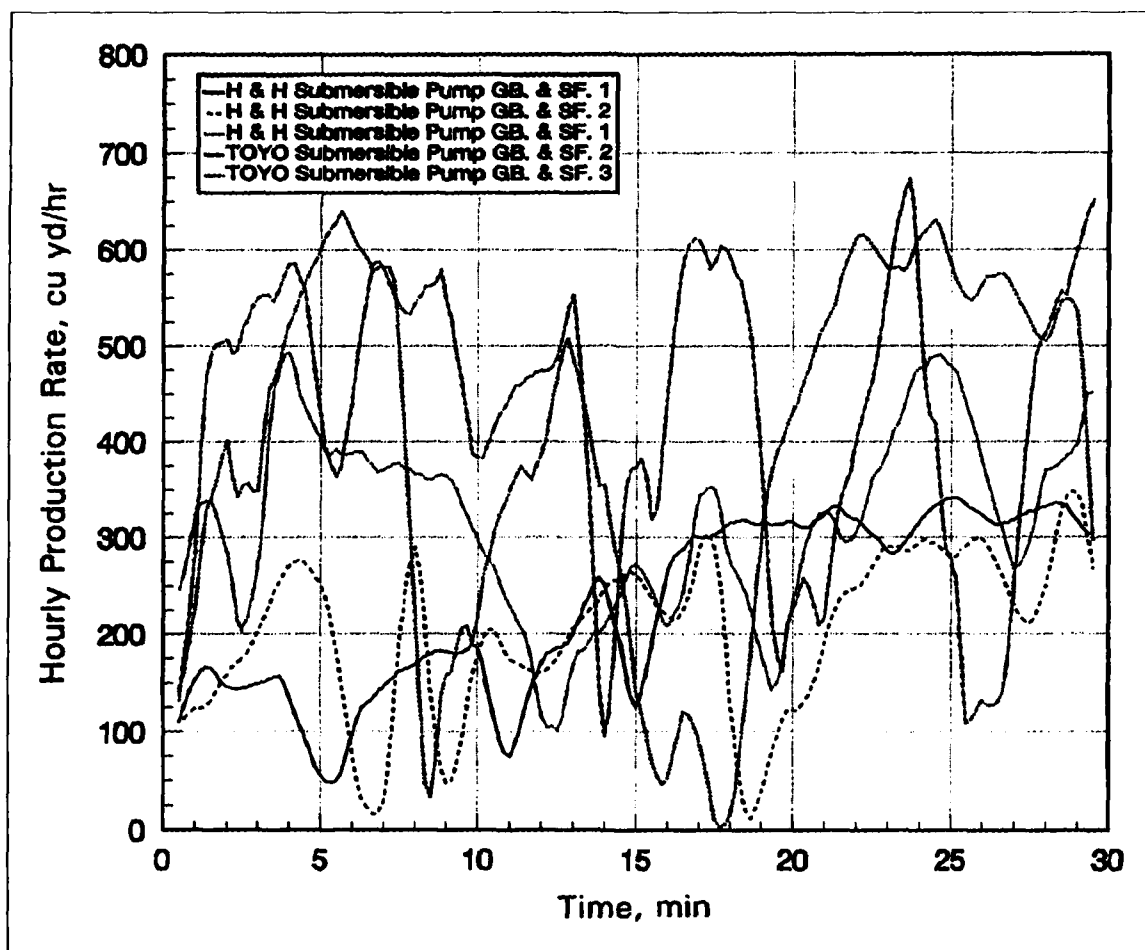

Figure 18. One-minute average production rates for the two submersible pumps with garbage bags and swim fins in the crater

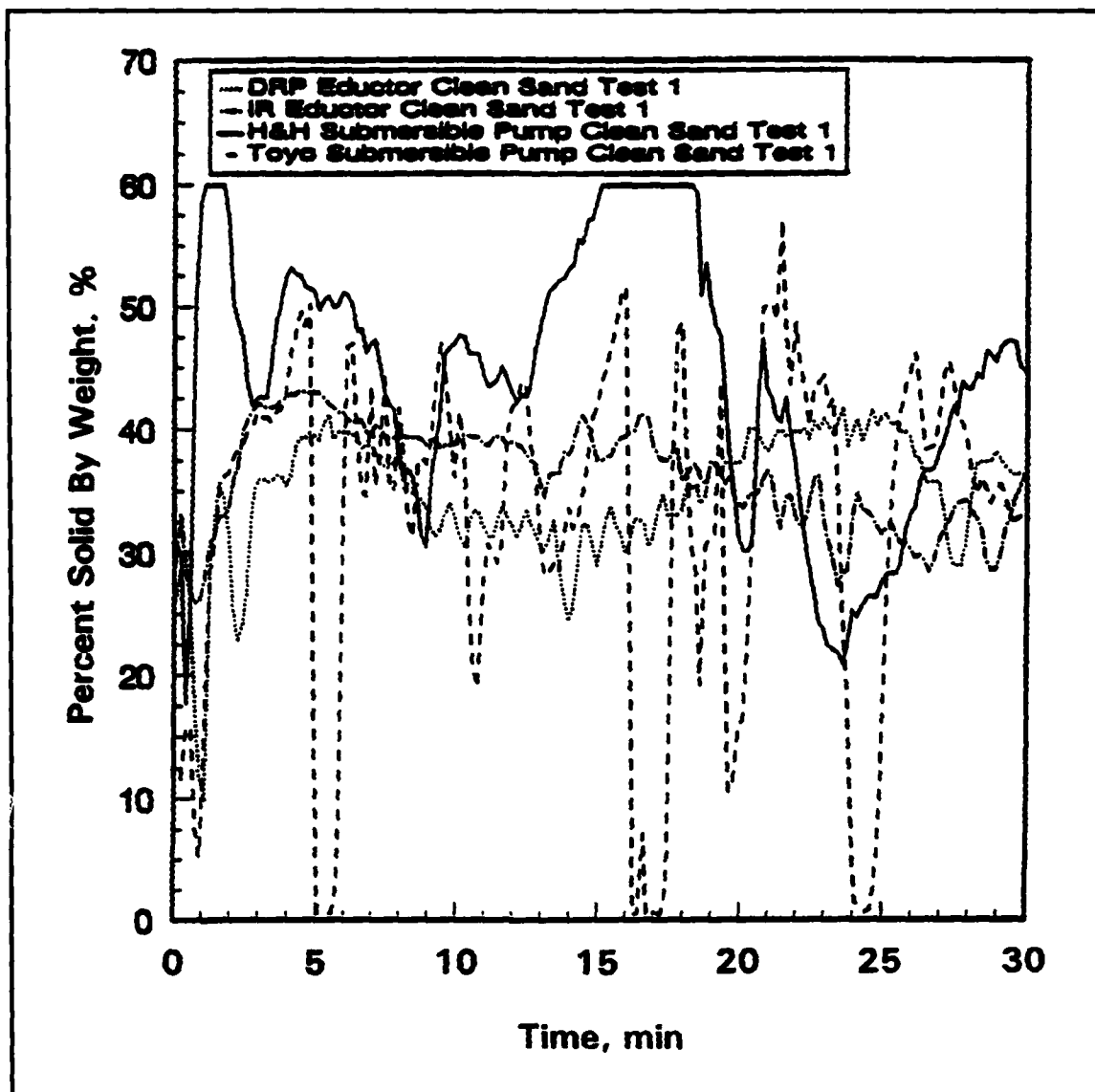

Figure 19. Percent solids by weight for one test of each pump in clean sand

pipe clogging is rarely a problem even when the eductor becomes clogged with debris because there is a rapid reduction in the external flow of material into the eductor.

It is worth noting the relative power consumption of each pump. As listed on Table 1, the eductors require a pump of approximately 330 hp to operate, while the submersible pumps require considerably less, 150 hp and 150 to 200 hp for the H&H Pump and the Toyo Pump, respectively. Consequently, the submersible pumps will require considerably less fuel to operate. At first glance, this may seem to greatly favor the submersible pumps. However, it should be noted that fuel cost may be a relatively low percentage of the total operating cost for a bypassing plant, thus making

other factors (such as easier operation and reduced chance of line plugging) more important.

Using Differential Pressure to Measure Specific Gravity

Due to the safety and regulatory complexities associated with using nuclear density meters, alternative methods of measuring slurry specific gravity are of interest to the Corps. With this in mind, a small experiment was developed to measure slurry specific gravity based on differential pressures. The pressure difference between two points in a vertical pipe is the result of the weight of the fluid in the pipe and any pressure loss due to pipe friction. For these tests, the weight of the slurry is directly related to the amount of sand in the slurry, and thus directly related to the slurry specific gravity.

Pressure differences were measured by a variable reluctance differential pressure transducer with a ± 5 -psi difference (psid) range. Two pipe taps located 10 ft apart on the vertical section of pipe transmitted the pressures back to the pressure transducer via plastic tubing. Figure 20 shows the configuration for the differential pressure experiment along with the location of the nuclear density gauge. Output from the differential pressure transducer was processed through a basic signal-conditioning unit which converted the transducer output into a suitable input for the test computer. The specific gravity of the slurry was calculated from the differential pressure without any adjustment for friction losses in the pipe between the two pressure measurements.

Figure 21 is an example plot of the slurry specific gravity recorded by the nuclear density meter and calculated from the differential pressure measurements during one of the 30-min tests (additional plots are contained in Appendix B, Plates 64-80). The two specific gravities track each other well with the specific gravity from the pressure measurements being about 10 percent larger than from the nuclear density meter. This difference between the two readings is in part due to the friction losses between the two pressure measurements for which no adjustment was made. Additionally, the difference between the two readings could result from the calibration of the pressure transducers or the nuclear density meter.

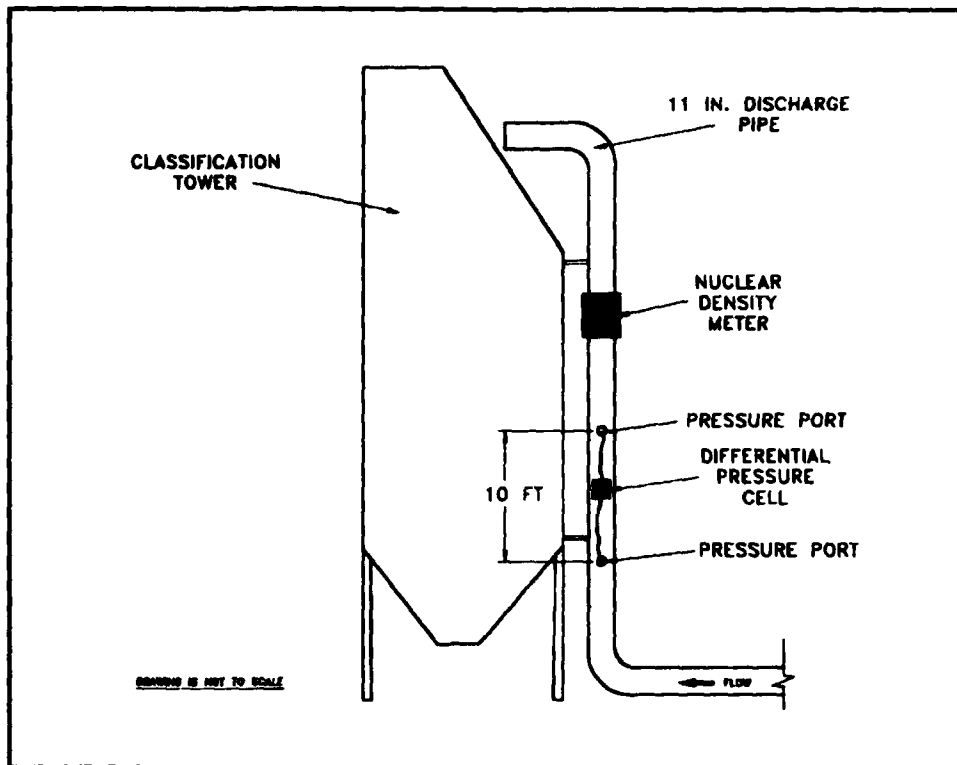

Figure 20. Equipment locations for the differential pressure experiment

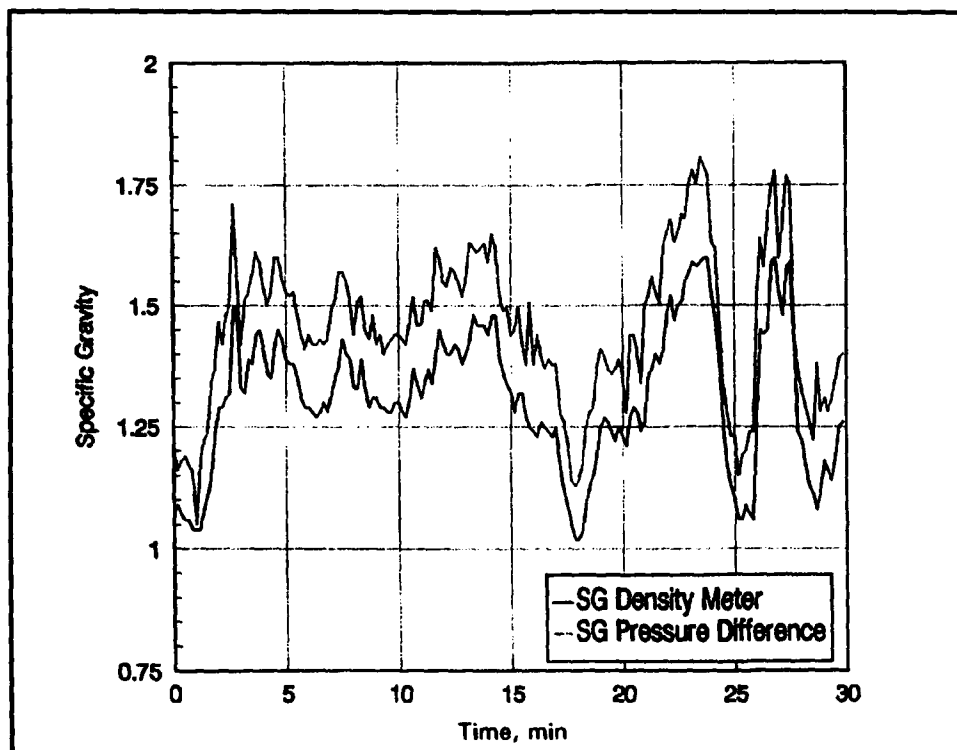

Figure 21. Comparison of specific gravity of the slurry as measured by the nuclear density meter and differential pressure

4 Conclusions and Recommendations

In clean sand, performance of the DRP eductor and the more conventional Indian River Inlet eductor are about the same. Performance in debris is a function of the type of debris. The grate and fluidizers on the DRP eductor allow better production in stone and garbage bags/swim fin debris than the Indian River Inlet eductor; however the DRP eductor grate is more prone to clogging with wood than the Indian River Inlet eductor. The Indian River Inlet eductor is more susceptible to stones entering into the suction chamber, reducing performance. For fixed plants where the eductor cannot be moved, production in a particular debris type can be optimized by selecting the correct combination of intake, grate, and fluidizer. Even with the proper design, production will be considerably lowered as debris accumulates. To achieve maximum production, the ability to move the eductor to a new location and/or remove the accumulated debris from the crater is required.

The H&H Pump as tested was not well suited to the types of debris tested. It was very susceptible to both rocks and wood. A rock guard, relatively easily fabricated (and also available from the manufacturer), could help solve these problems, though possibly reducing performance somewhat.

The Toyo Pump performed the best overall and was only bettered by the Indian River inlet eductor when pumping wood debris.

The lack of a requirement for constant operator control and the relative immunity to line plugging make the eductors well suited to long term bypass operations. The choice of a particular eductor will depend on the type and amount of debris present. For those locations that are consistently saturated with debris, the eductors' ability to operate with debris will become less important, while the ability to remove and reposition the eductor or clean out the debris will become more important. In other words, areas with large amounts of debris will be better suited to a more mobile bypassing system. Submersible pumps do not require a large supply pump, may not require a booster pump, and thus are well suited for mobile bypass systems.

The Toyo Pump's high production and apparent ruggedness make it a possible candidate for bypass operations (particularly those not suited for eductors), but the level of operator control required to achieve the high production rates and the potential for line plugging must be considered. The H&H Pump's low cost and light weight (less than 400 lb) make it well suited for smaller, aperiodic bypass and dredging jobs.

The Vicksburg District's Monroe Navigation Field Office used similar logic before purchasing a lightweight submersible pump to maintain locks and dams on the Red River. For small aperiodic dredging jobs, the purchase price can be a more important factor than production rate. A detailed description of the Monroe Navigation Field Offices' use of submersible pumps on the Red River, is presented in Neilans, Clausner, Coldiron and Corkern (1993).

The DRP Eductor's ring jet is not necessary to achieve low pullout forces during retrieval of the DRP eductor. Operating the eductor with the discharge line blocked for several minutes (i.e. backflushing) should be sufficient to completely fluidize the sand surrounding the eductor, allowing pullout forces of 20,000 lb or less. While the ring jet will also allow fluidization of the sand surrounding the eductor, the additional construction expense and plumbing requirements to use the ring jet do not appear to be justified.

The tests of the differential pressure gauge's ability to measure slurry specific gravity showed that this method appears to give reliable estimates when compared with a calibrated nuclear density meter. Additional work in this area could be worthwhile, however, the need to have the measurements take place on a vertical section of pipe of substantial height (approximately 20 ft) make it somewhat impractical for many dredging operations.

References

- Clausner, J. E. (1988). "Jet pump sand bypassing at the Nerang River Entrance, Queensland, Australia." *Proceedings of the 1988 National Beach Preservation Technology Conference*. Florida Shore and Beach Preservation Association, Gainesville, Florida, 345-355.
- _____. (1990). "Submersible pumps for sand bypassing," *Dredging Research Information Exchange Bulletin* DRP-90-3, August.
- _____. (1991). "Sand bypassing at Indian River Inlet, Delaware." *Proceedings of Coastal Sediments '91*. ASCE, Seattle, Washington, 1177-1191.
- Jones, C. P., and Mehta, A. J. (1980). "Inlet sand bypassing systems in Florida," *Shore and Beach*, 36(1), 27-30.
- McNair, E. C., Jr. (1976). "A sand bypassing system using a jet pump." *Proceedings, Fifteenth Coastal Engineering Conference*. ASCE, 1342-1360.
- Neilans, P., Clausner, J., Coldiron, J., and Corkern, C. (1993). "Maintenance applications of a submersible pump on the Red River Waterway," *World Dredging Mining & Construction*, 29(9), 10-12.
- Richardson, T. W., and McNair, E. C., Jr. (1981). "A guide to the planning and hydraulic design of jet pump remedial sand bypassing systems," Instruction Report HL-81-1, U.S. Army Engineer Waterways Experiment Station, Vicksburg, MS.
- U.S. Army Corps of Engineers. (1991). "Sand bypassing system selection," Engineer Manual EM 1110-2-1616, Washington, D.C.
- Wakefield, A. W. (1992). "Hybrid jet-centrifugal pump systems in dredging and sand bypassing." *Proceedings XIIIth World Dredging Conference*. Eastern Dredging Association, 275-295.
- Watts, G. M. (1962). "Mechanical by-passing of littoral drift at inlets," *Journal, Waterways and Harbors Division*, ASCE, 88(WW1), 88-99.

Appendix A

Submersible Pump Characteristics

H&H Model PF50 × 8 pump

Power source: DH177CT 275-hp diesel/hydraulic pump power unit on a tandem axle trailer capable of pumping 75 gpm at 2,000 psi.

Diesel engine: 6 cylinder Cummins 6BTA5.9 with 90-gal fuel tank

Hydraulic Motor: Type M76 × 5.0, oil hydraulic gear type, 75 gpm at 2,000 psi. Hydraulic motor with direct drive turning a radial flow centrifugal impeller at 900 rpm. No rock guard was installed on the test pump, but they are available.

Pump: 8-in.-diam, maximum capacity of 6,000 gpm, maximum head of 84 ft, capable of passing a maximum spherical solid 4 in. in diameter. Width: 25 in. Length: 34 in. Height: 30 in. Weight: 350 lb

Pump shell and impeller: 20 percent chrome and nickel alloy inlay (for use in sand), capable of running dry, no mechanical seals

Water jets: 12 water jets with 1/2-in.-diam nozzles, 8 nozzles at the perimeter of the base pointed straight down, 4 nozzles located inside the base edge and pointed inward towards the impeller. A small (4 in.) separate hydraulic pump placed at the water surface normally provides water to the nozzles at 35 to 40 psi. Suspended sand in the crater water clogged the jetting pump. Water from the eductor supply pump at about 50 psi was used for the jetting nozzles.

Toyo DP-150B

Power source: 275-hp diesel engine driving a 210-kW (460 v, 300 amp) diesel generator

Electric motor: 150 hp

Pump: 10-in.-diam discharge, maximum capacity 4,240 gpm, maximum head 82.5 ft, capable of passing a maximum spherical solid 4.75 in. in diameter.

Diameter: 5 ft

Height: 9 ft

Weight: 8,500 lb

Pump shell and impeller: Pump has high chrome iron standard wear parts with an external agitator, situated in front of suction intake, maximum 705 rpm.

Pump performance curves, as provided by the manufacturers, are on the following pages.



H & H PUMP CO.
18100 HWY 190 EAST
HAYMOND, LA 70401

TOTAL
HEAD
FEET

MODEL: PF50x8

IMPELLER: CAST

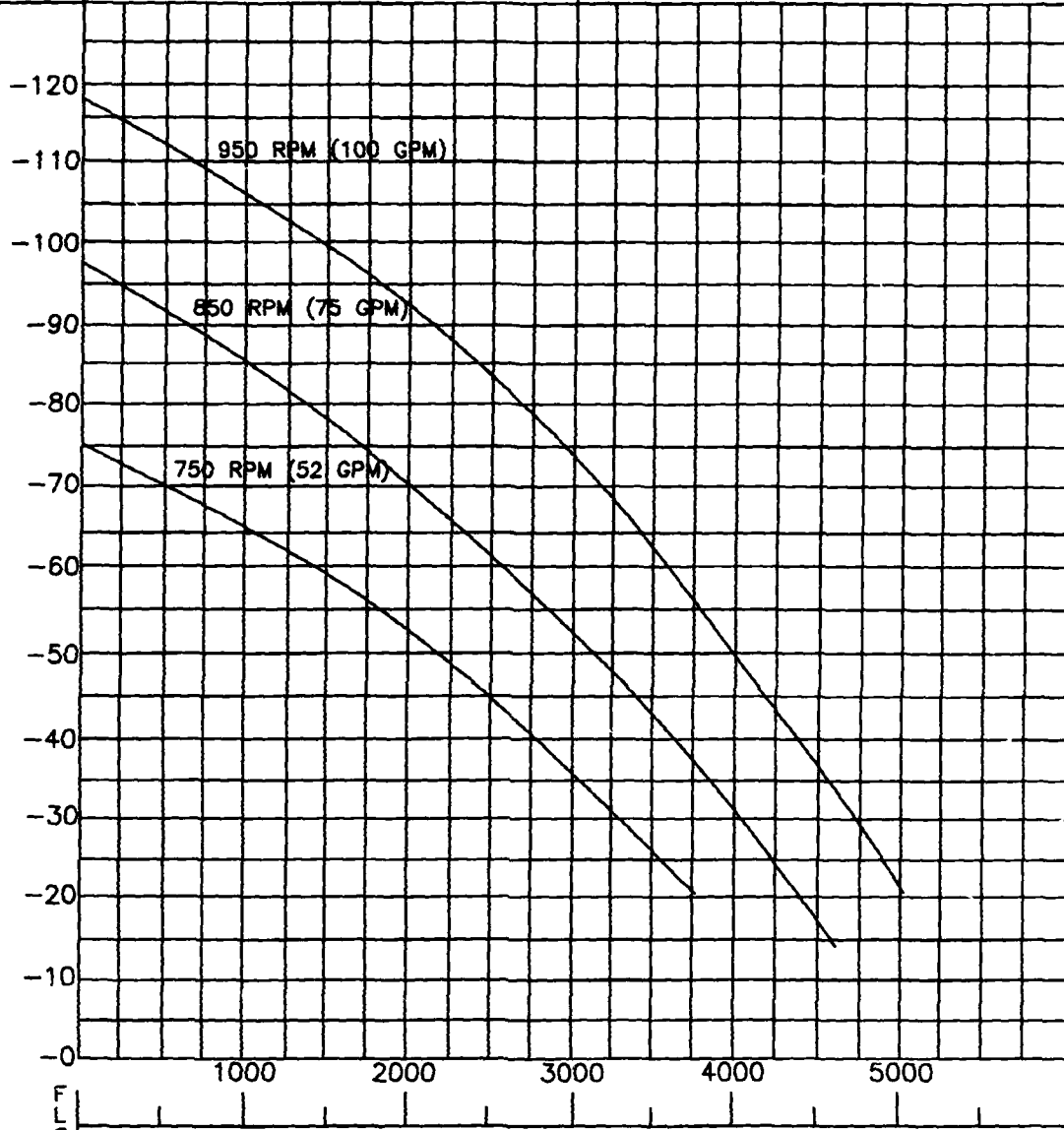

FLOW

GPM WATER

52 GPM M76x4.0 MOTOR
75 GPM M76x5.0 MOTOR
100 GPM M76x6.0 MOTOR

TOYO
PUMPS

HEAVY DUTY SUBMERSIBLE AGITATOR PUMPS

TYPE DP-150B

PERFORMANCE CURVES

The Pumping

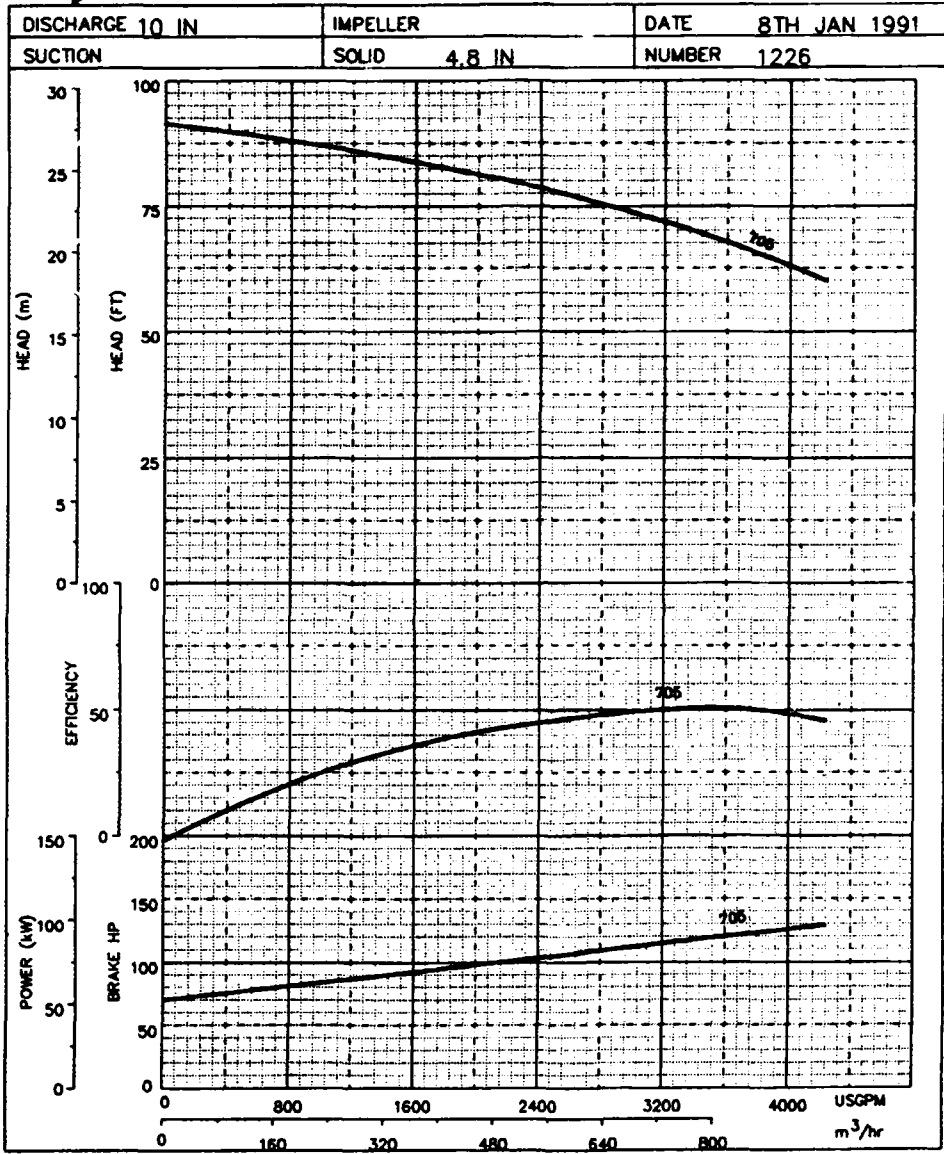

Curves are approximate. Pump is guaranteed for one set of conditions. Capacity, head, and efficiency are based on shop tests when handling clear, cold, fresh water at a temperature of not over 55 degrees and not over 15' suction lift.

Appendix B

Graphical Results From All Tests

The following appendix is divided into three parts. The first part, Plates B1 through B47, are test results from each individual test and include booster pump pressures, percent solids by weight, slurry velocity and production rates. The second part, Plates B48 through B63, are comparisons of production rates for the clean sand tests and debris combination for the eductors and submersible pumps. The third part, Plates B64 through B80, are comparisons of specific gravity measurements between results from the nuclear density meter and the differential pressure gauge.

Test Results DRP Eductor Clean Sand Test 1

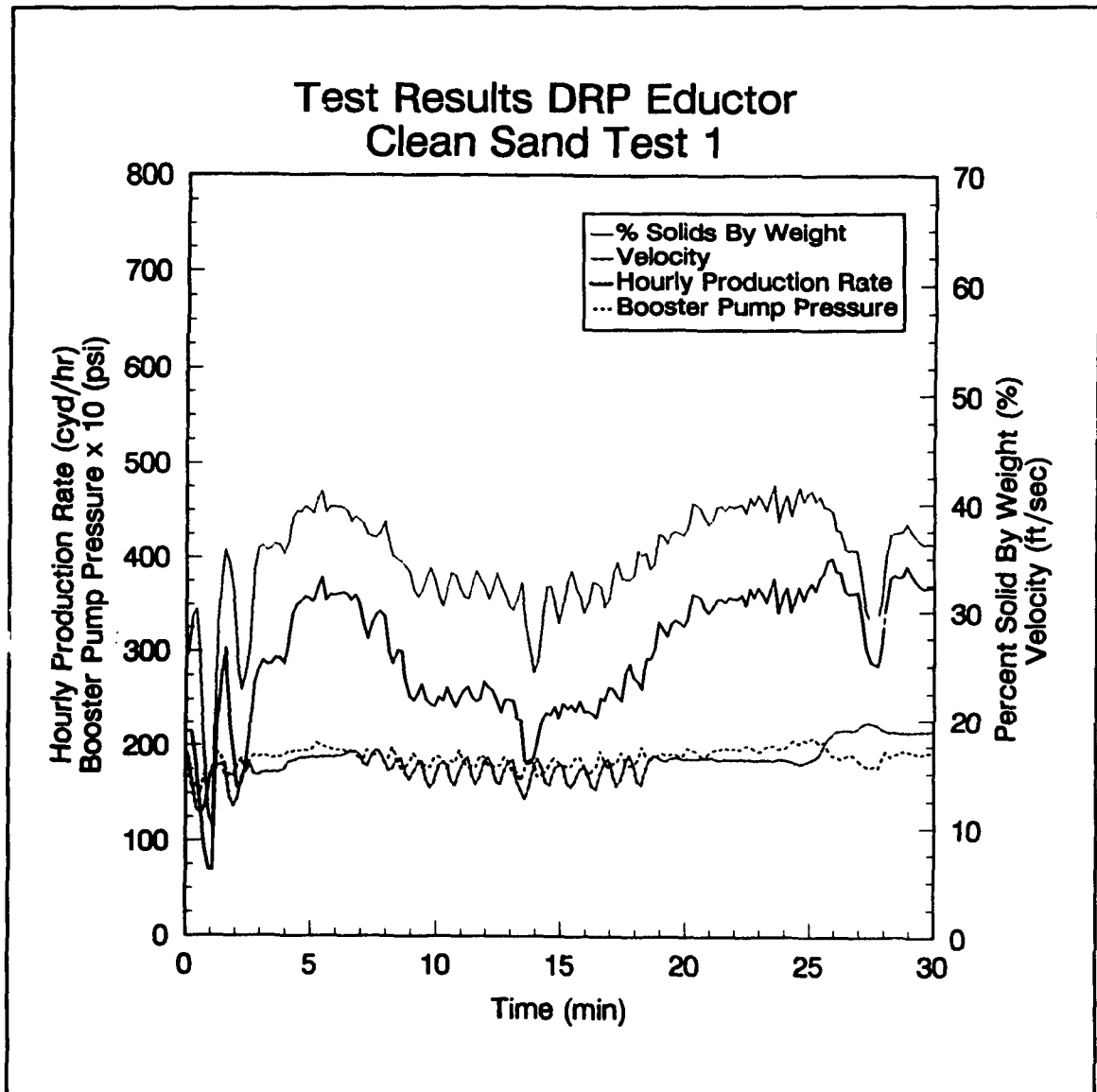

Test Results DRP Educator Clean Sand Test 2

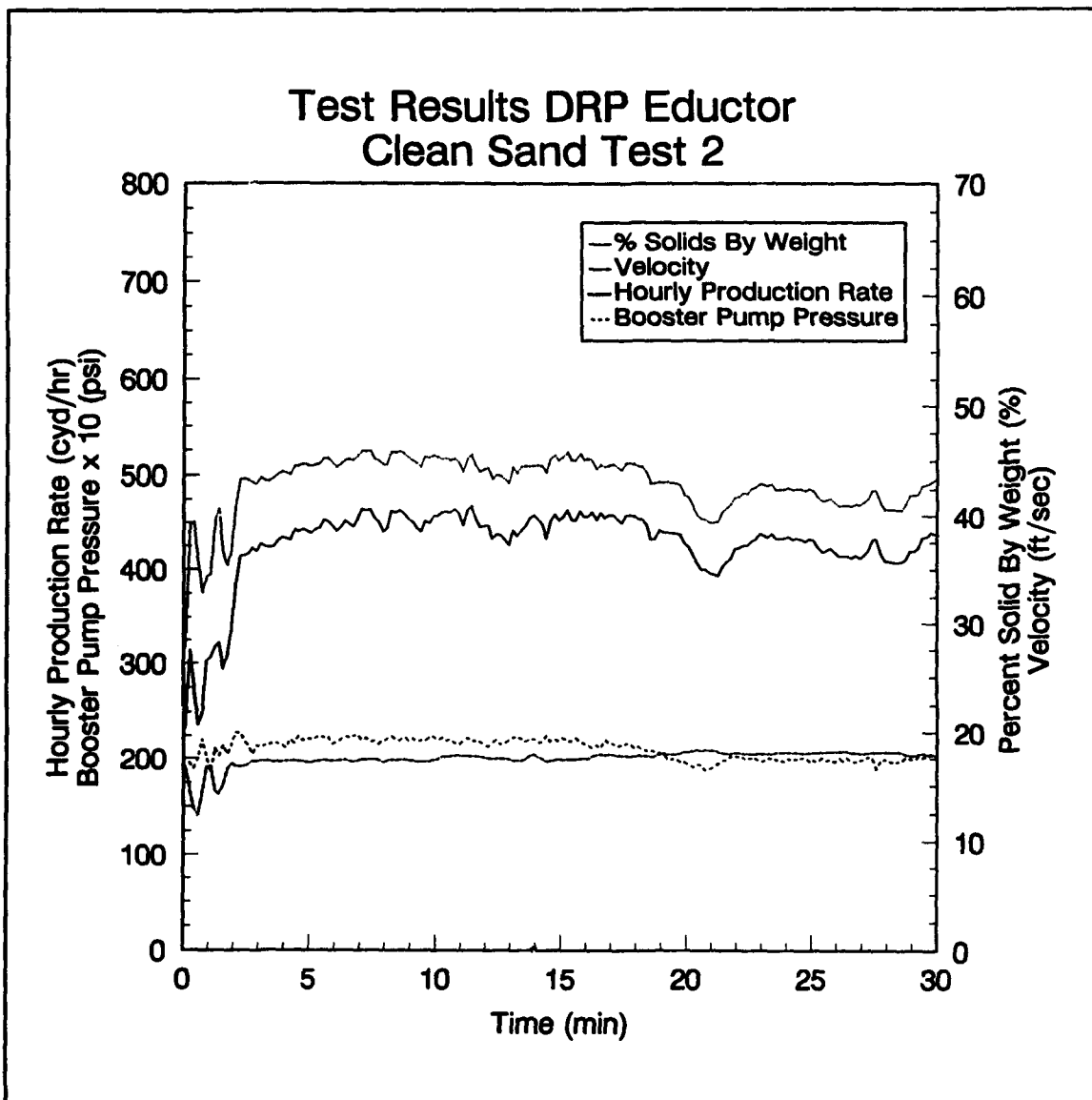

Test Results DRP Educator Clean Sand Test 3

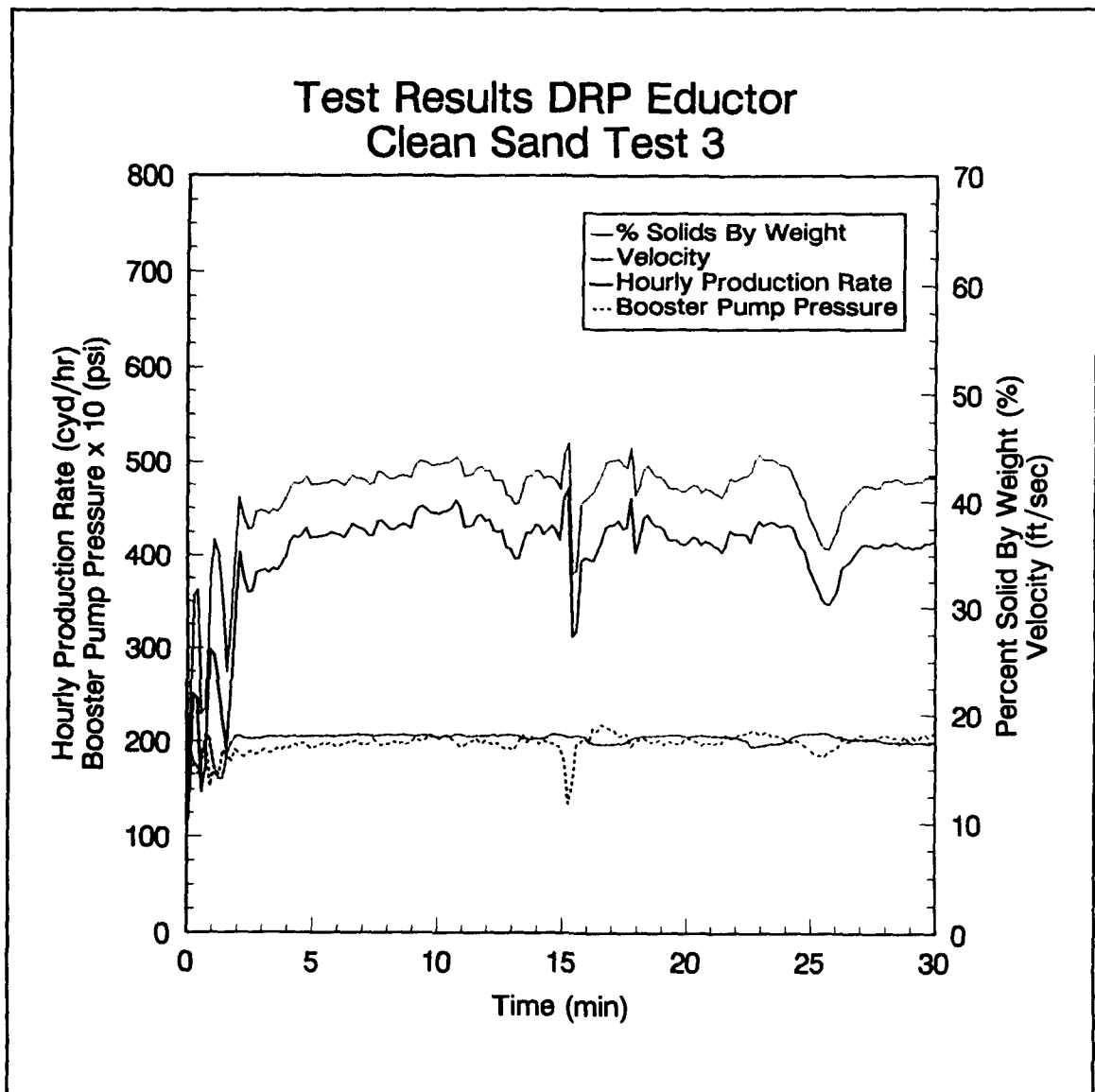

Test Results DRP Eductor Aluminum Cans Test 1

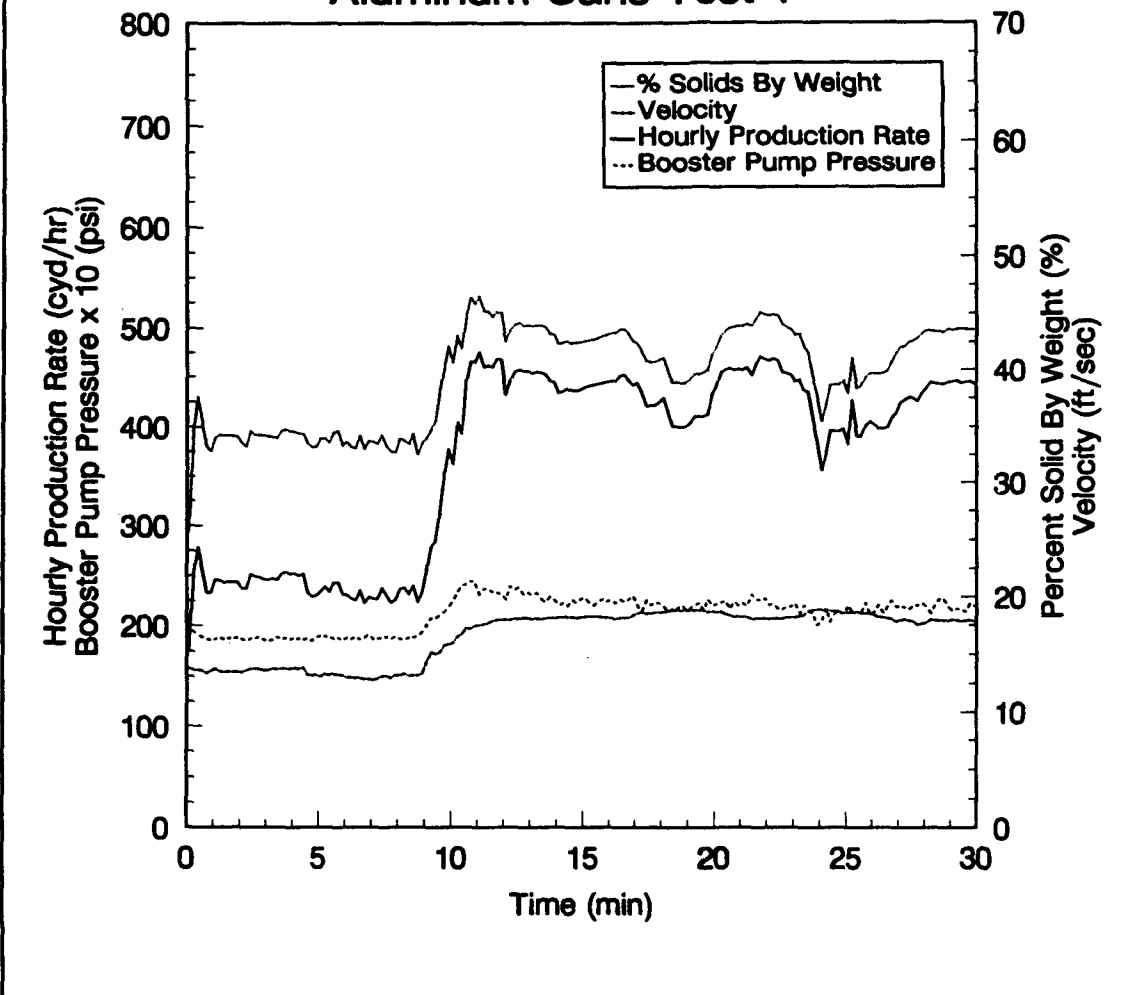

Test Results DRP Educator Brick and Concrete Test 1

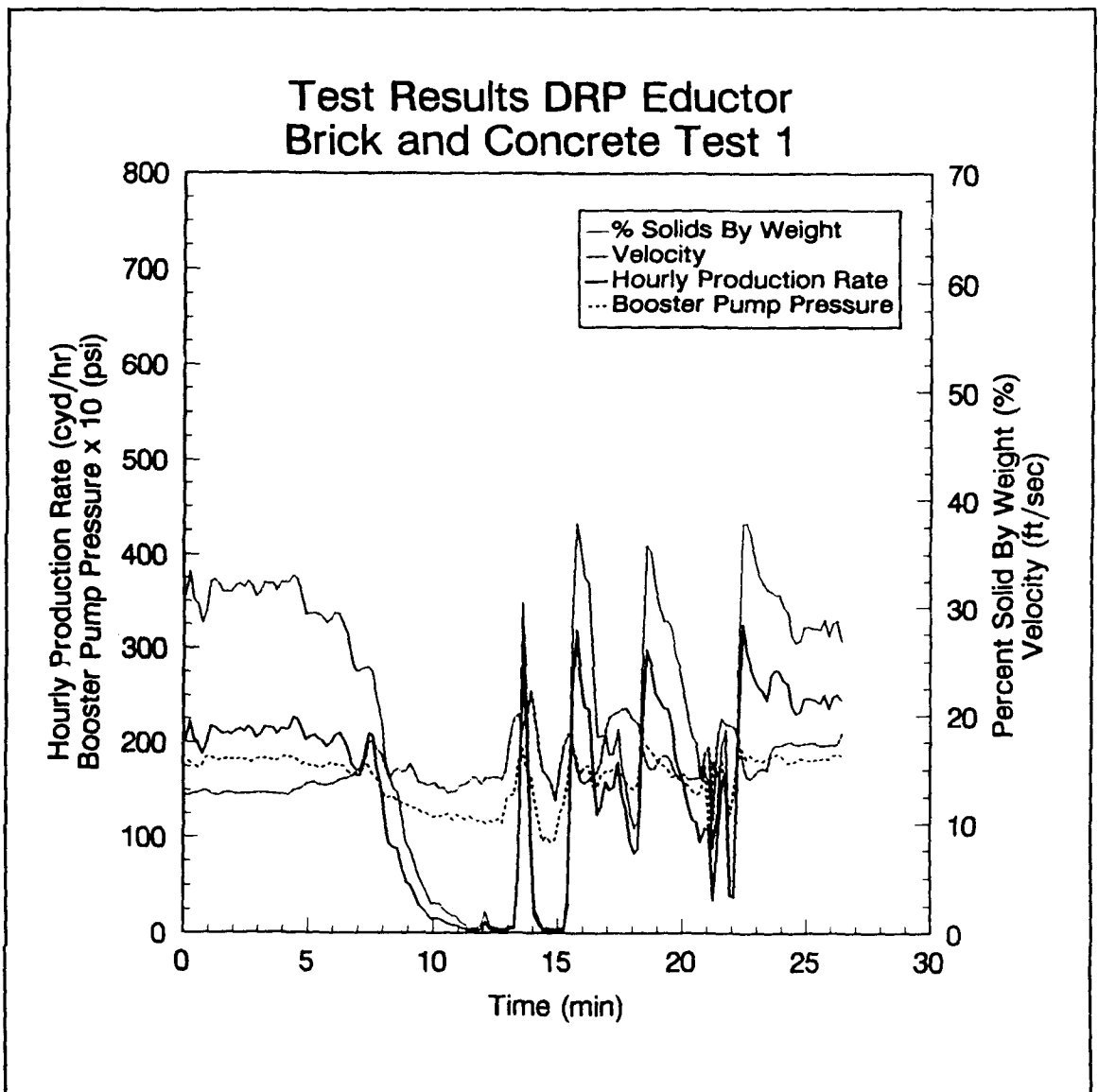

Test Results DRP Educator Garbage Bags & Swim Fins Test 1

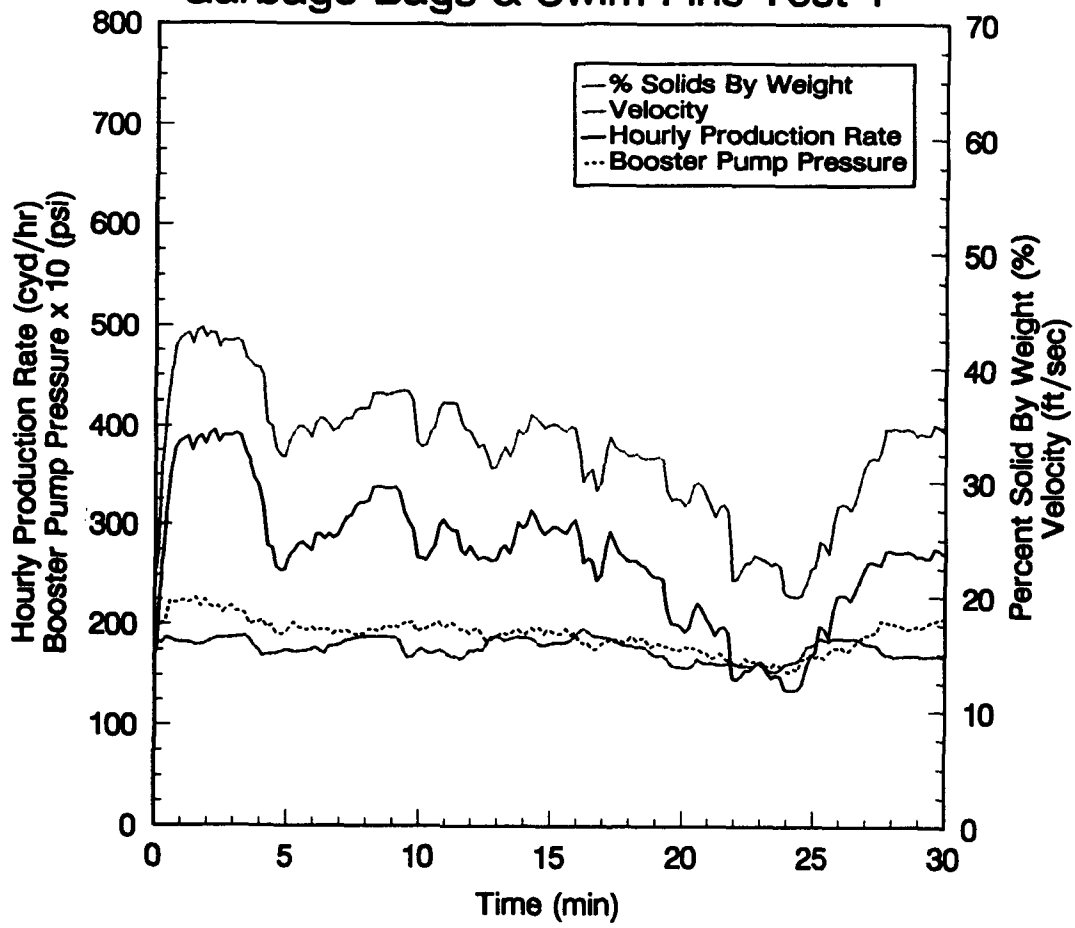

Test Results DRP Eductor Garbage Bags & Swim Fins Test 2

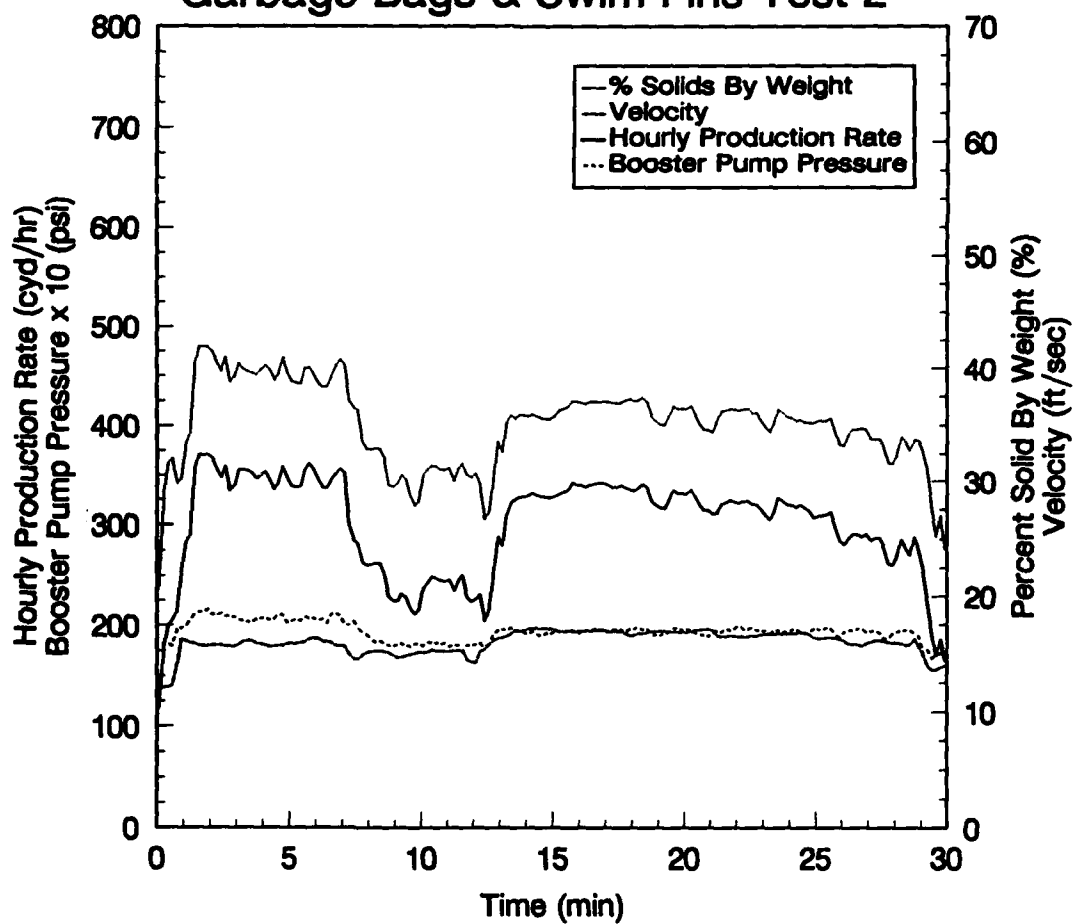

Test Results DRP Eductor Garbage Bags & Swim Fins Test 3

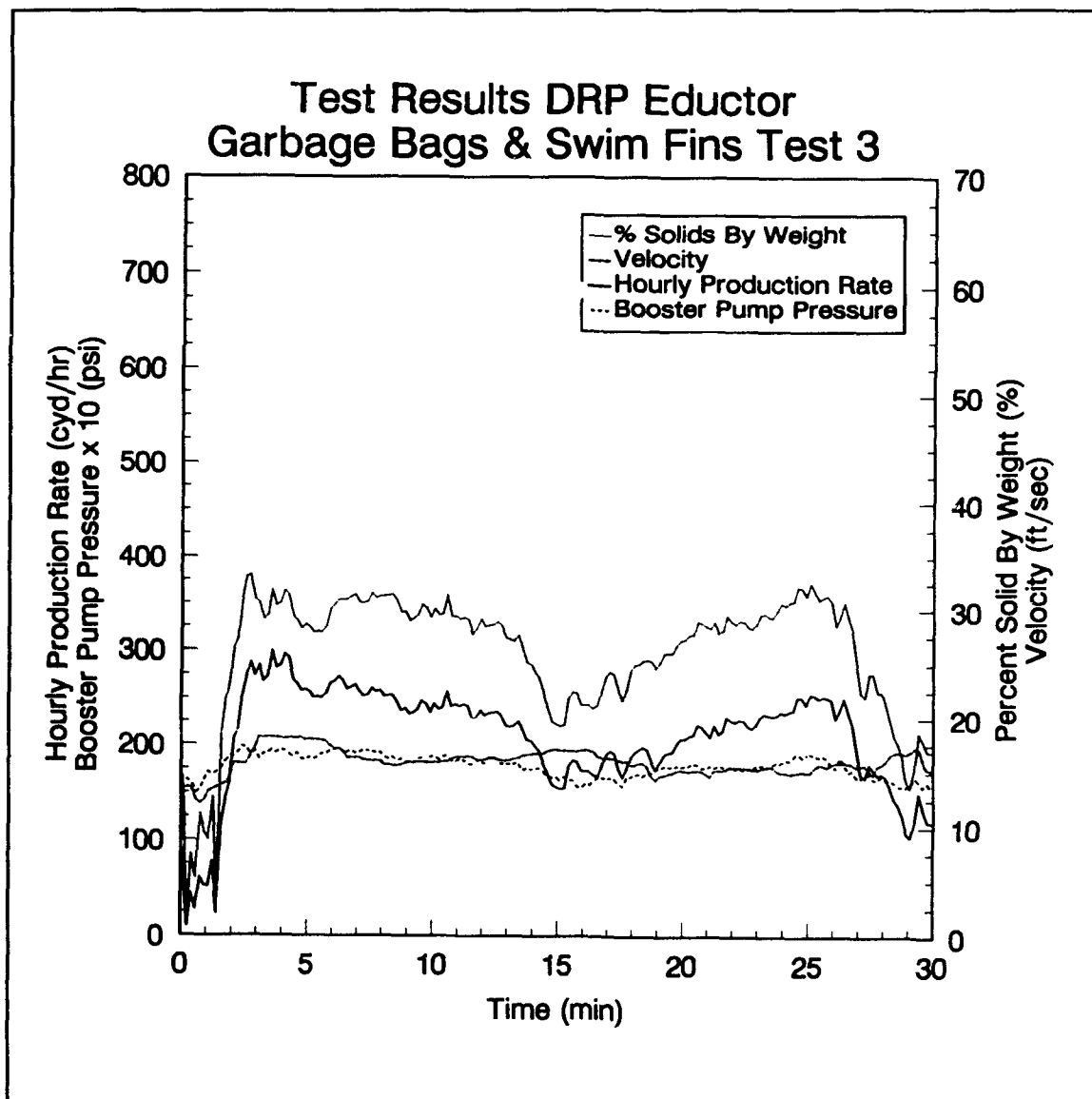

Test Results DRP Educator Garbage Bags & Swim Fins Test 4

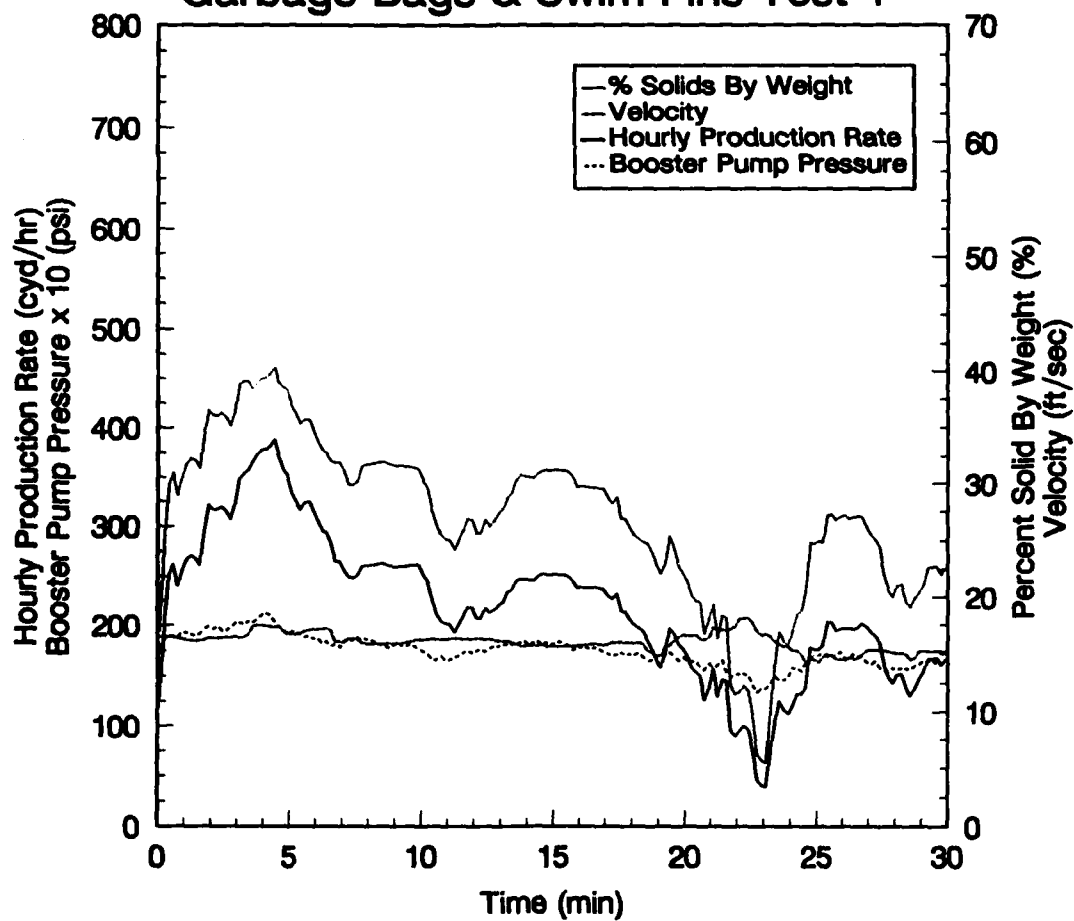

Test Results DRP Eductor Riprap Test 1

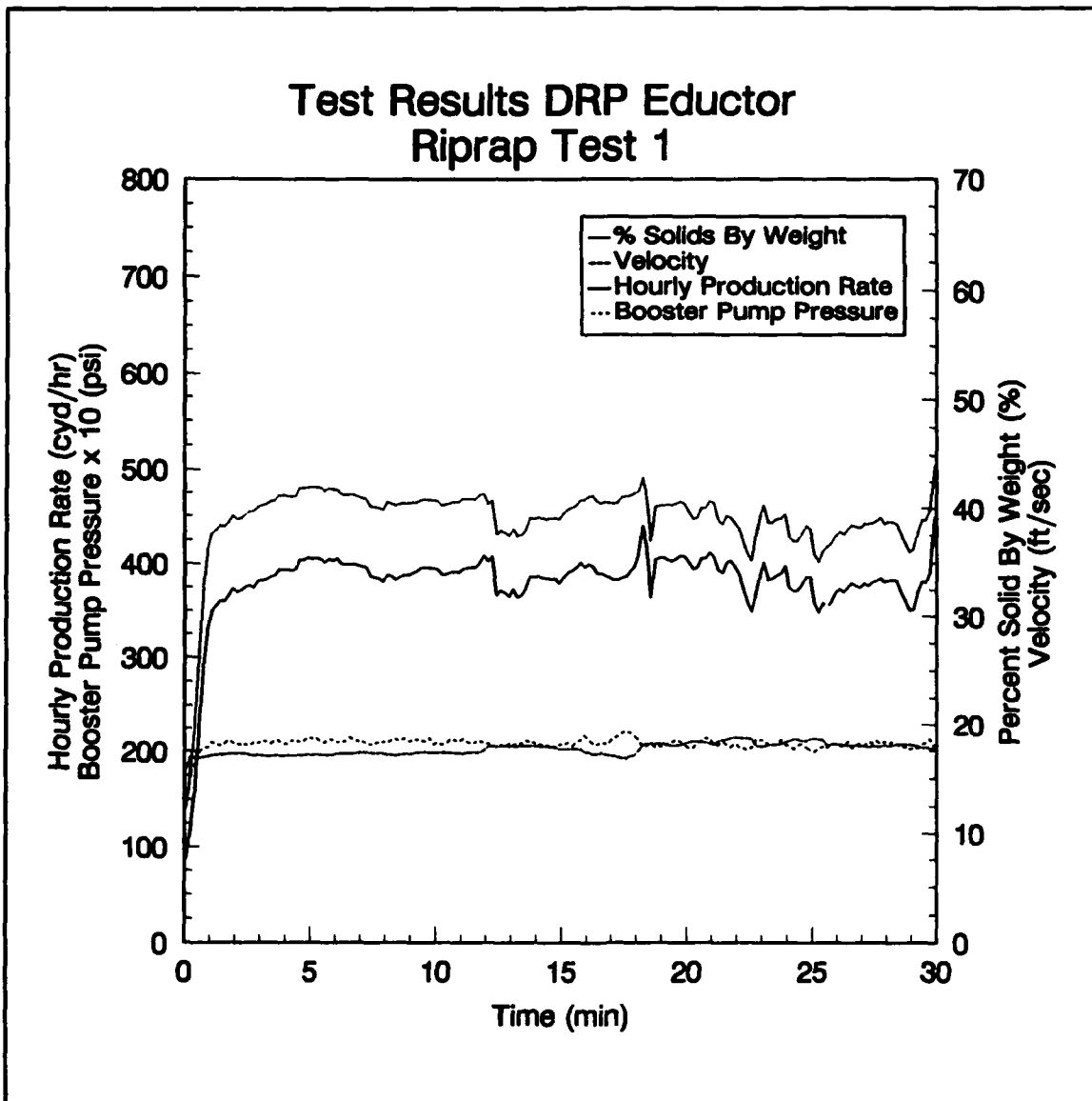

Test Results DRP Eductor Riprap Test 2

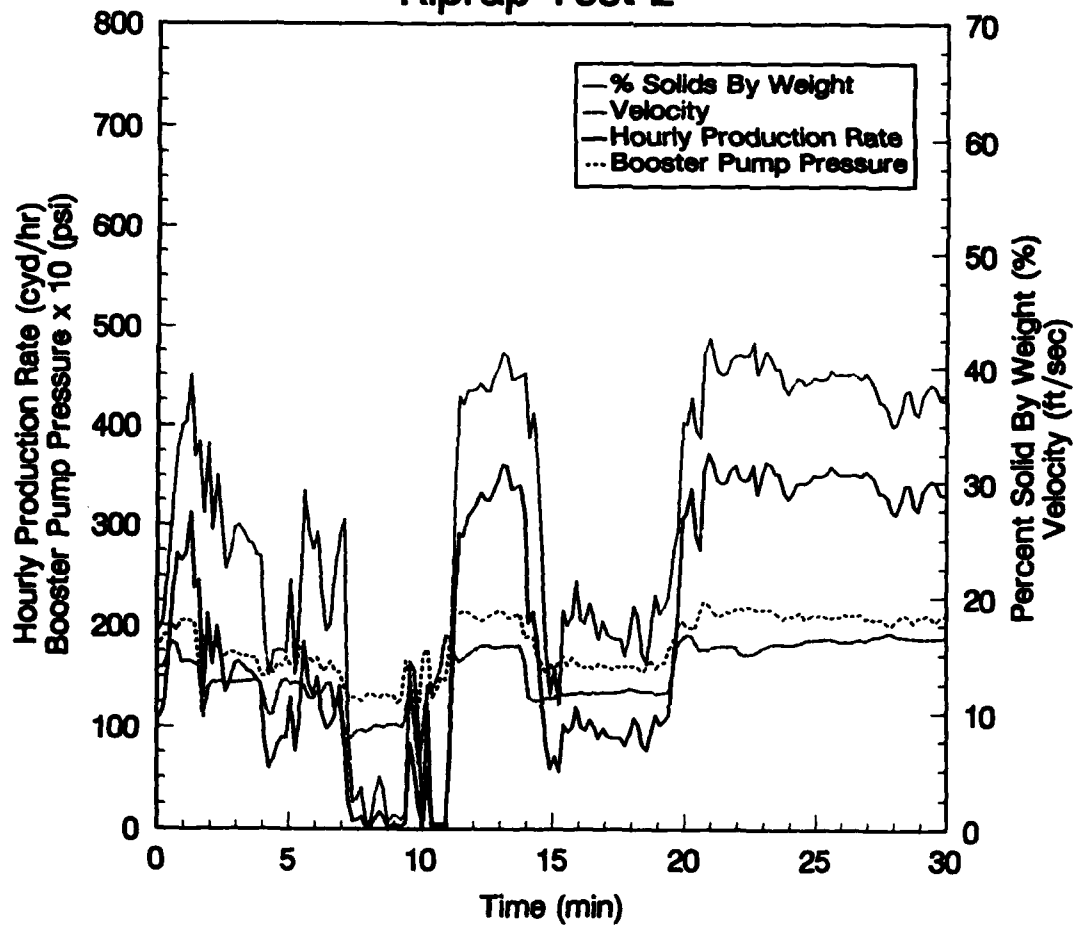

Test Results DRP Eductor Riprap Test 3

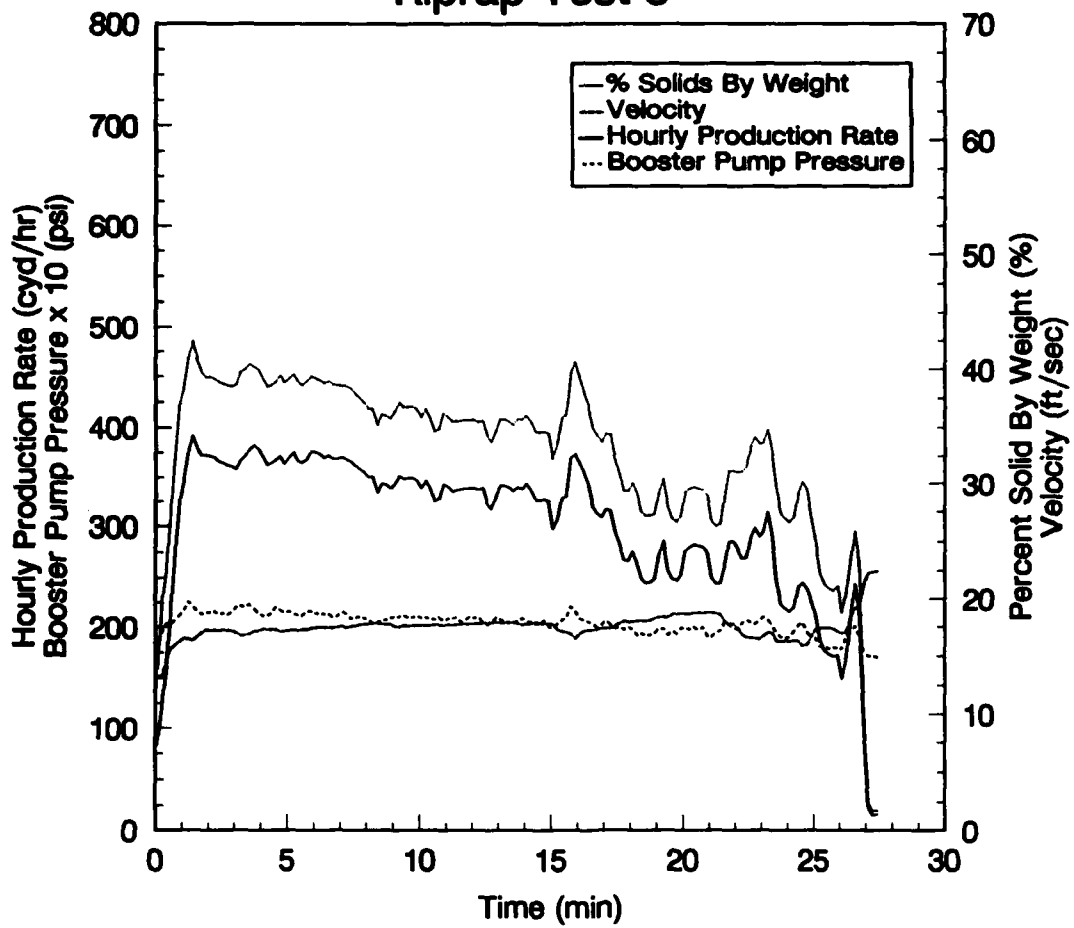

Test Results DRP Educator Riprap Test 4

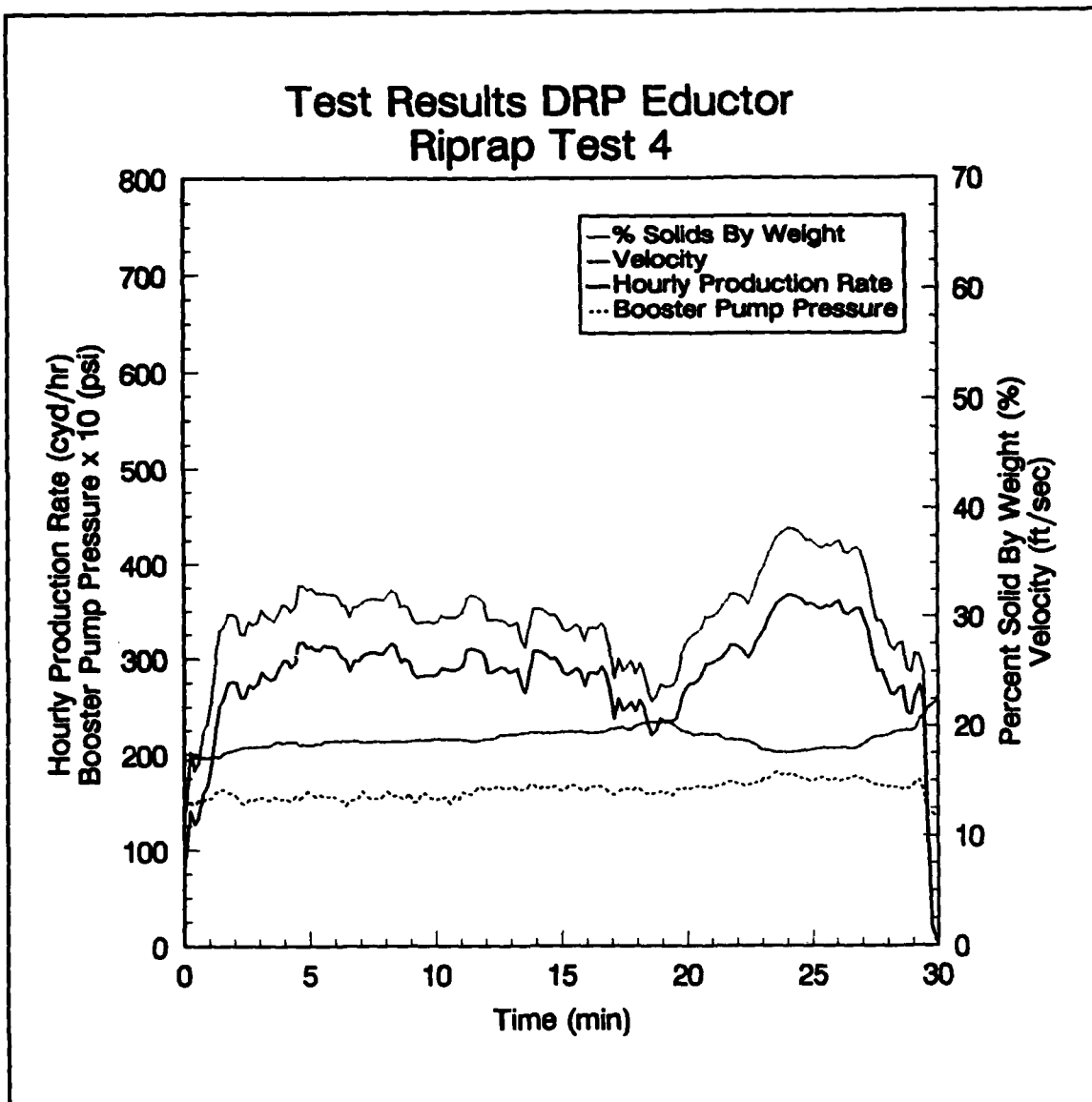

Test Results DRP Educator Pure Sand Test 1

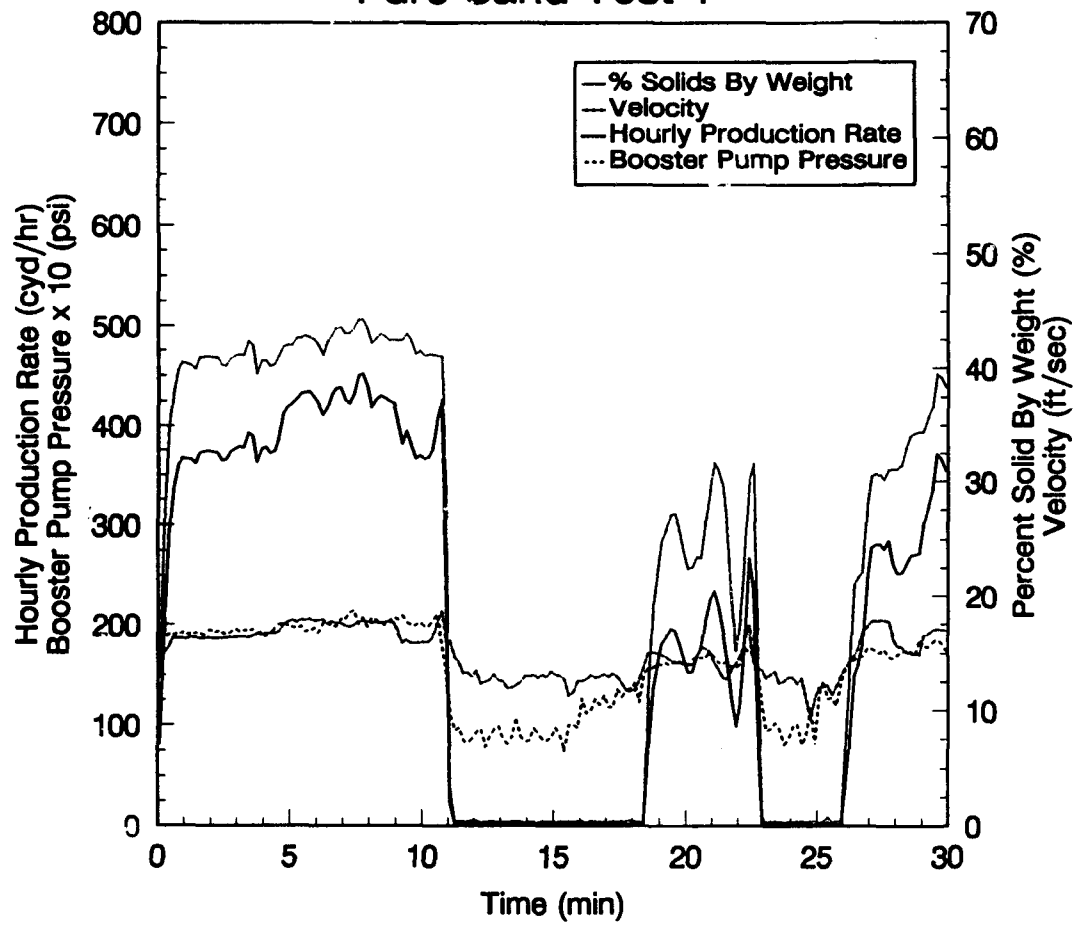

Test Results DRP Educator Wood Test 1

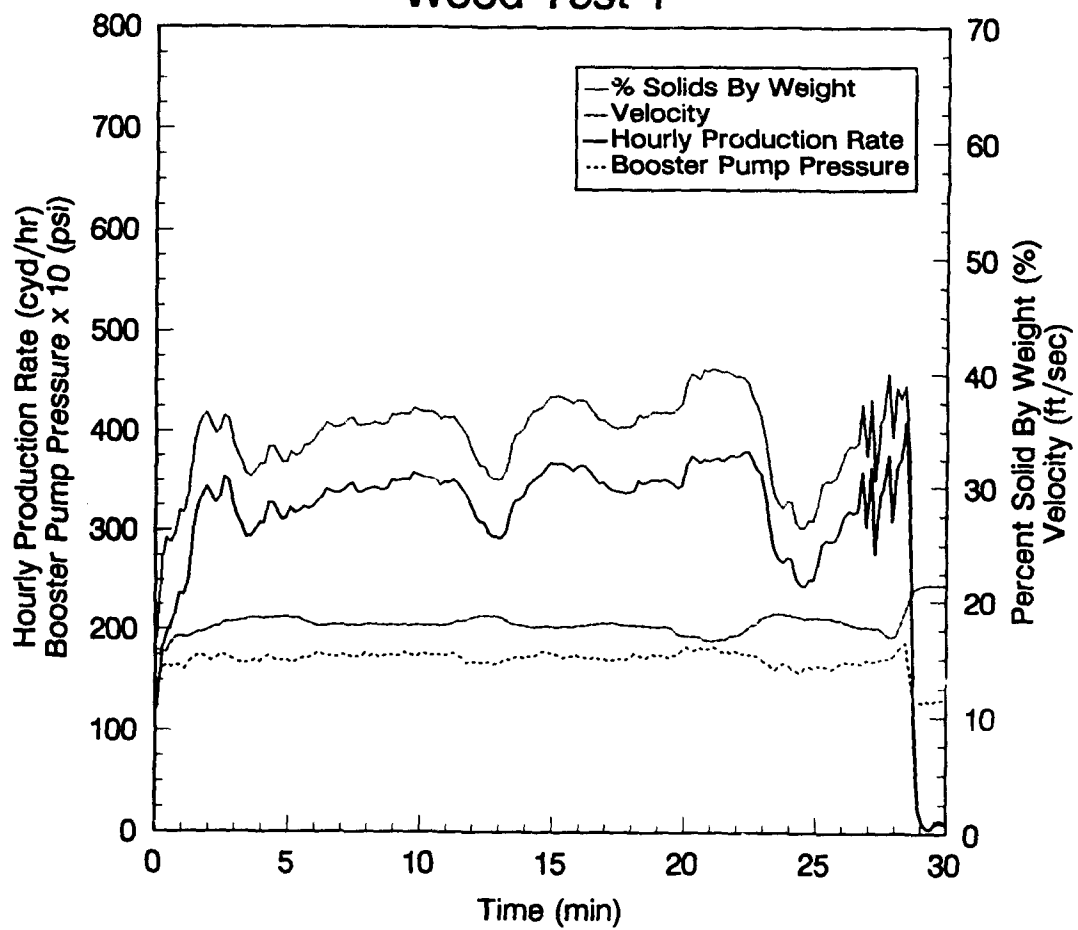

Test Results DRP Educator Wood Test 2

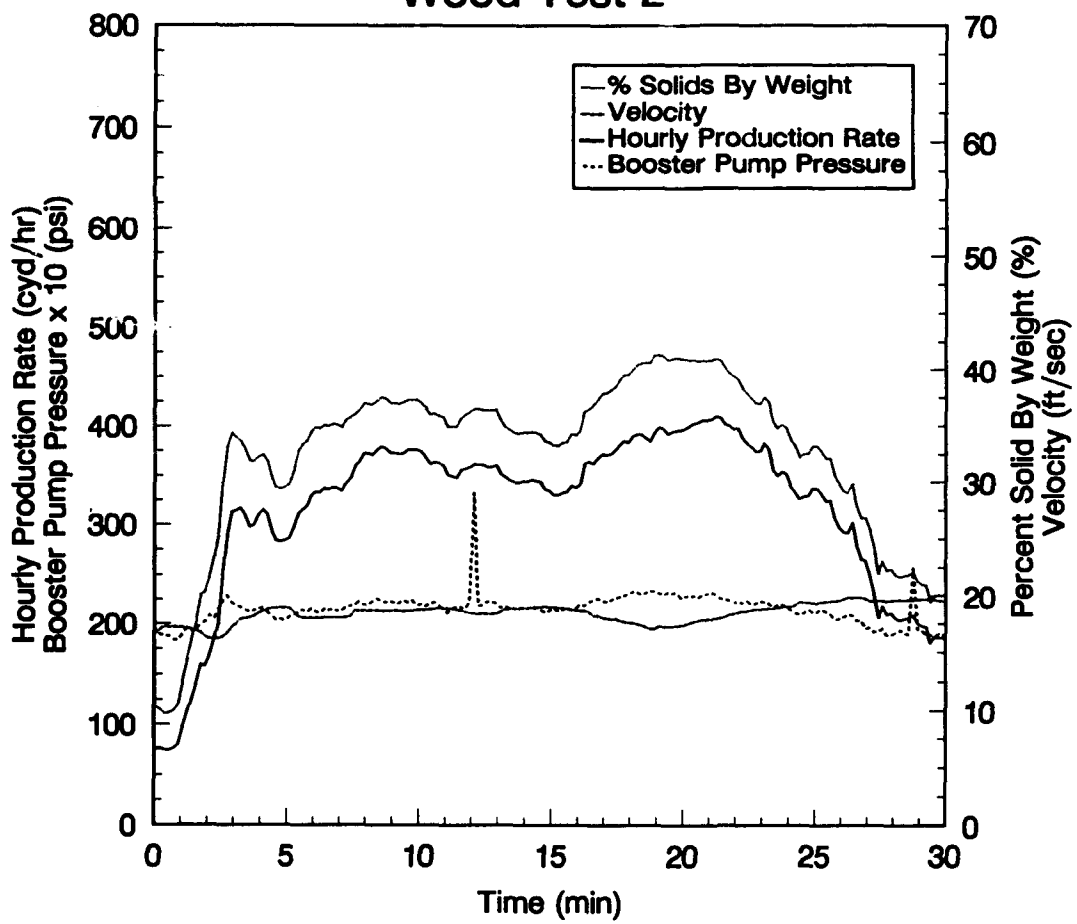

Test Results DRP Eductor Kelp Test 1

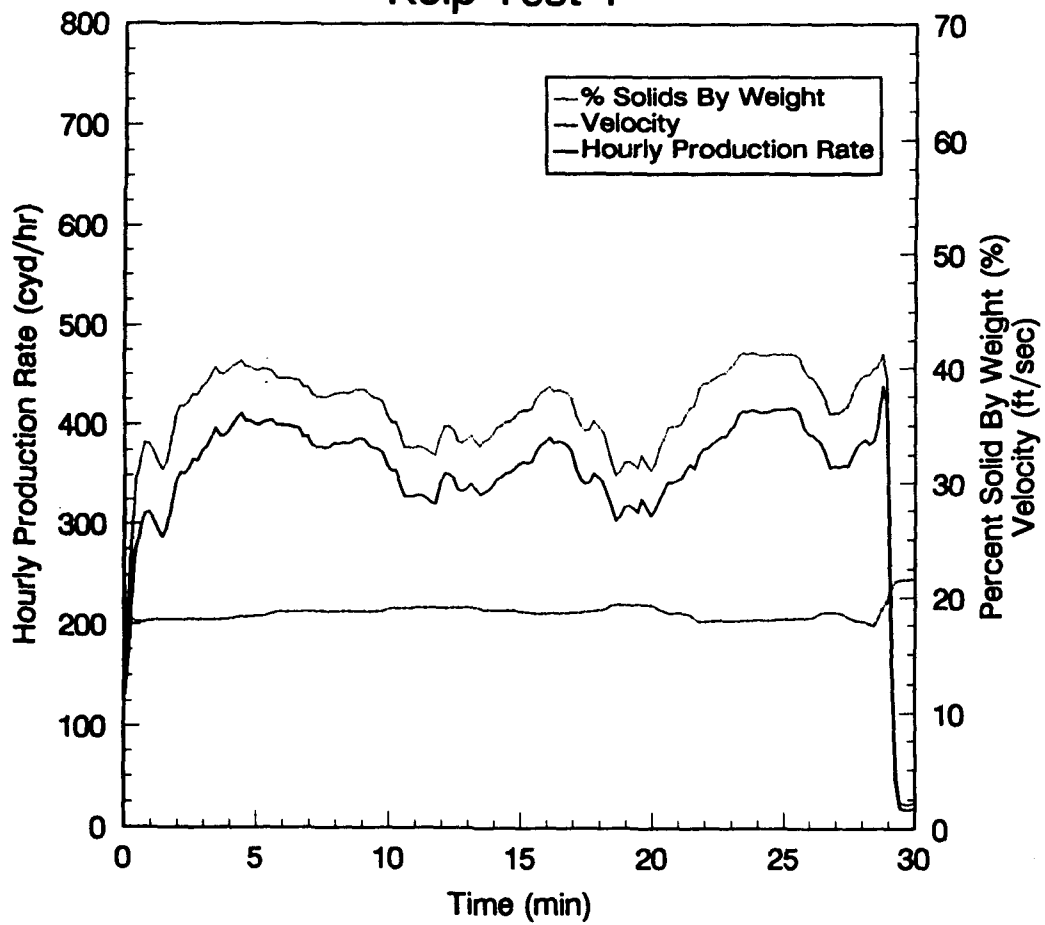

Test Results IR Eductor Garbage Bags and Swim Fins Test 1

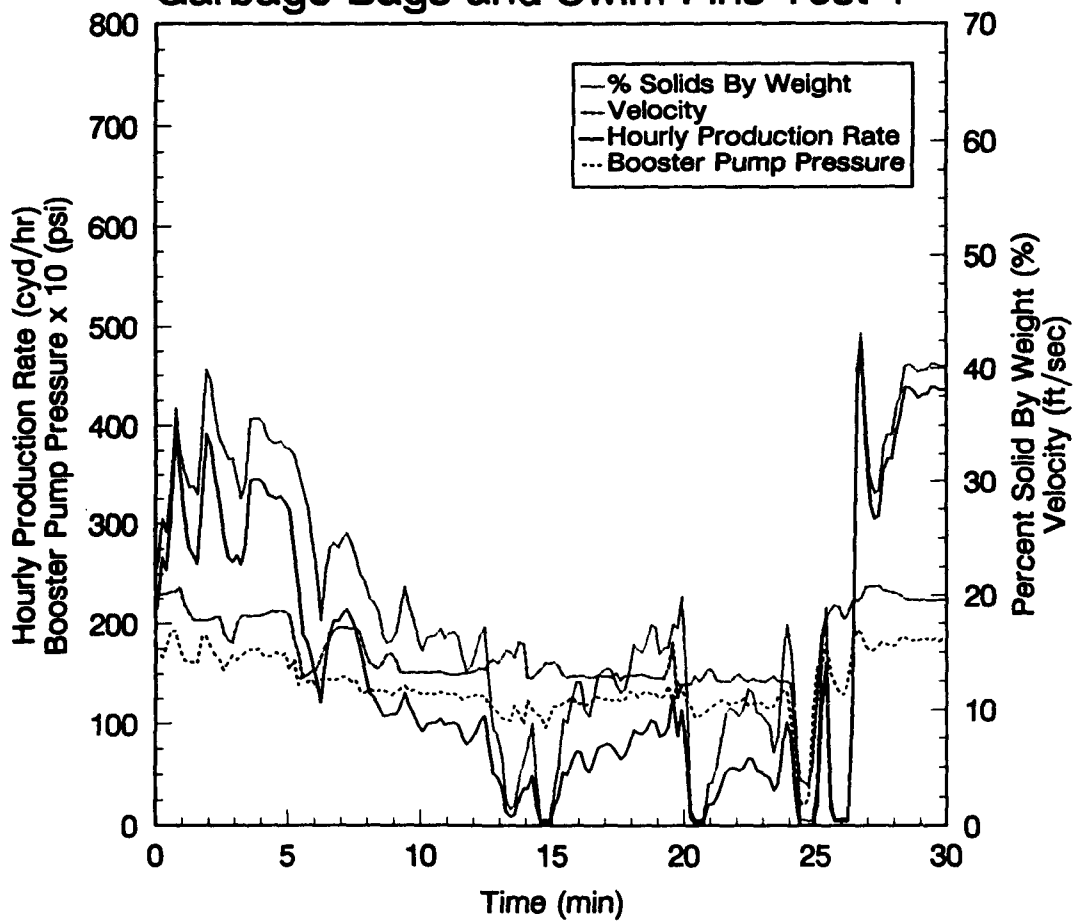

Test Results IR Eductor Garbage Bags and Swim Fins Test 2

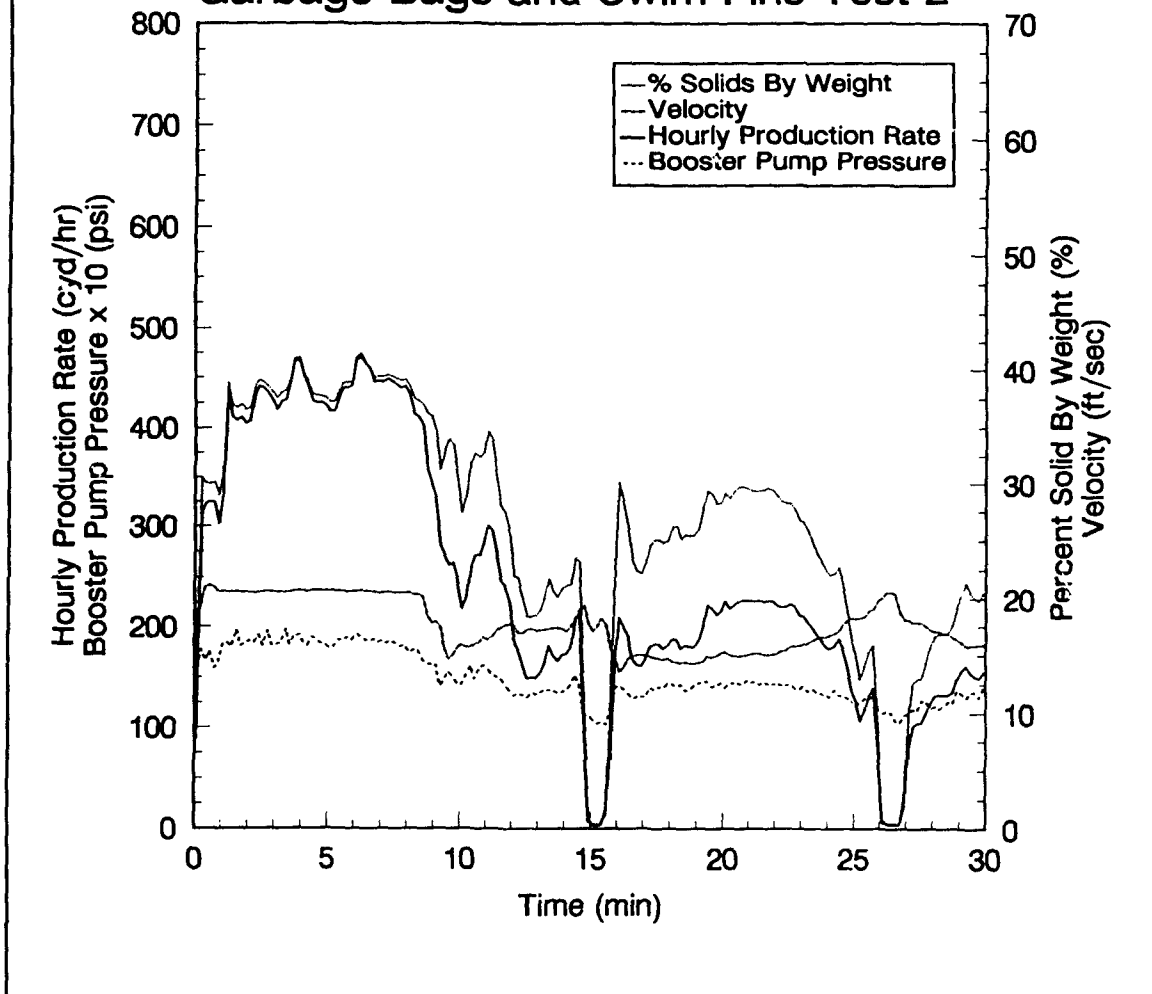

Test Results IR Eductor Garbage Bags and Swim Fins Test 3

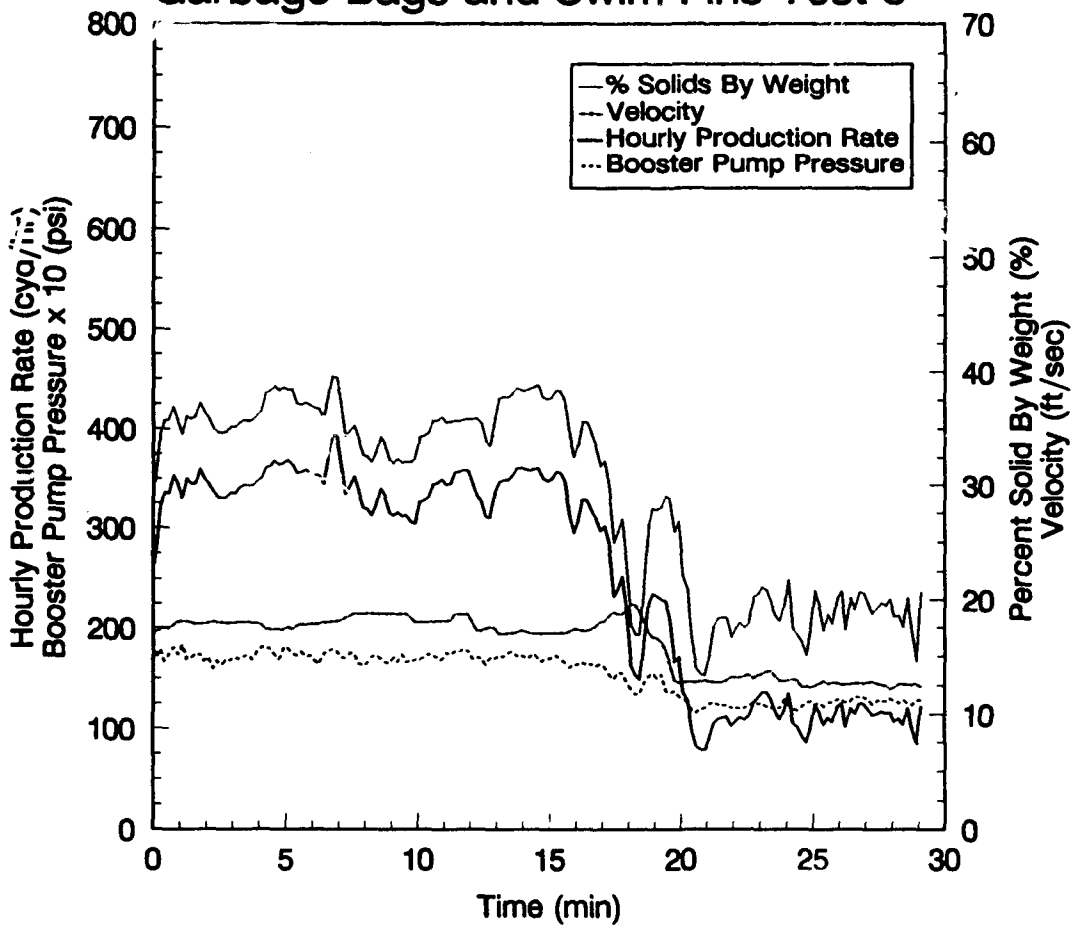

Test Results IR Eductor Wood Test 1

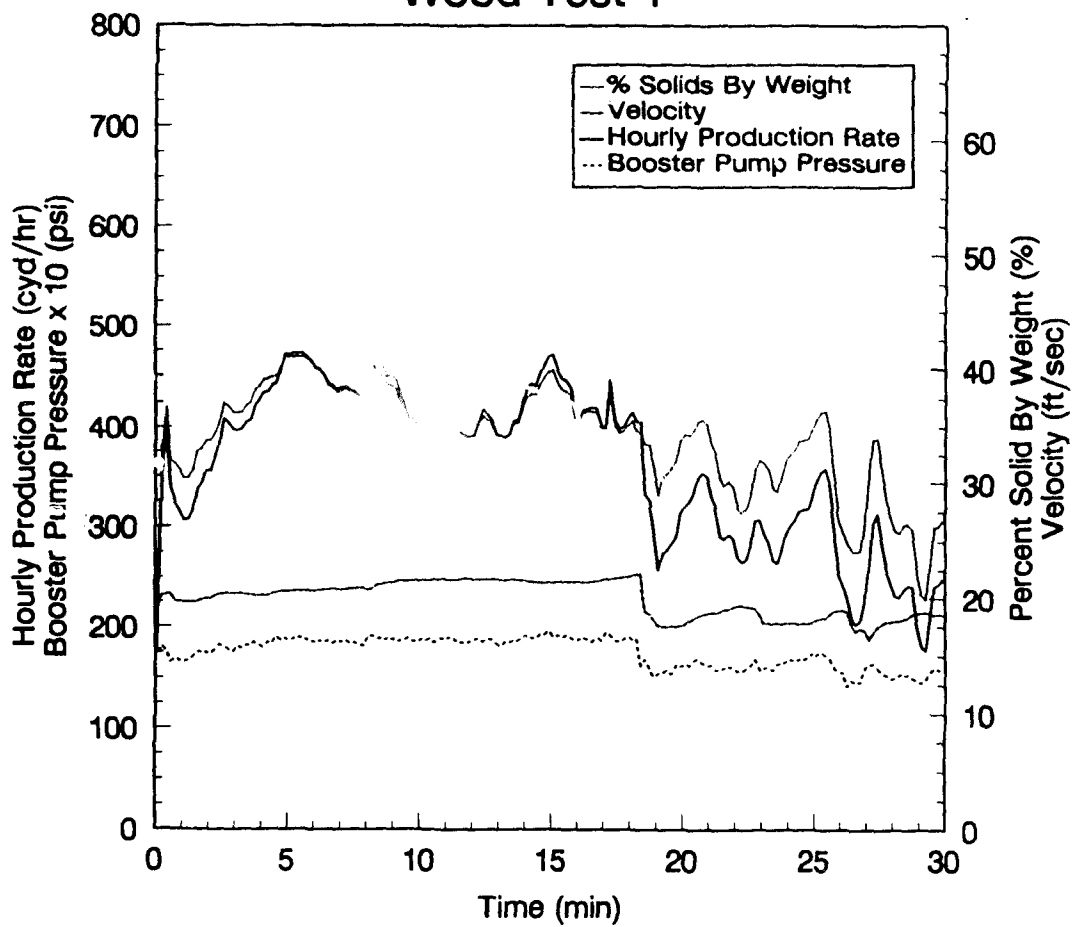

Test Results IR Eductor Wood Test 2

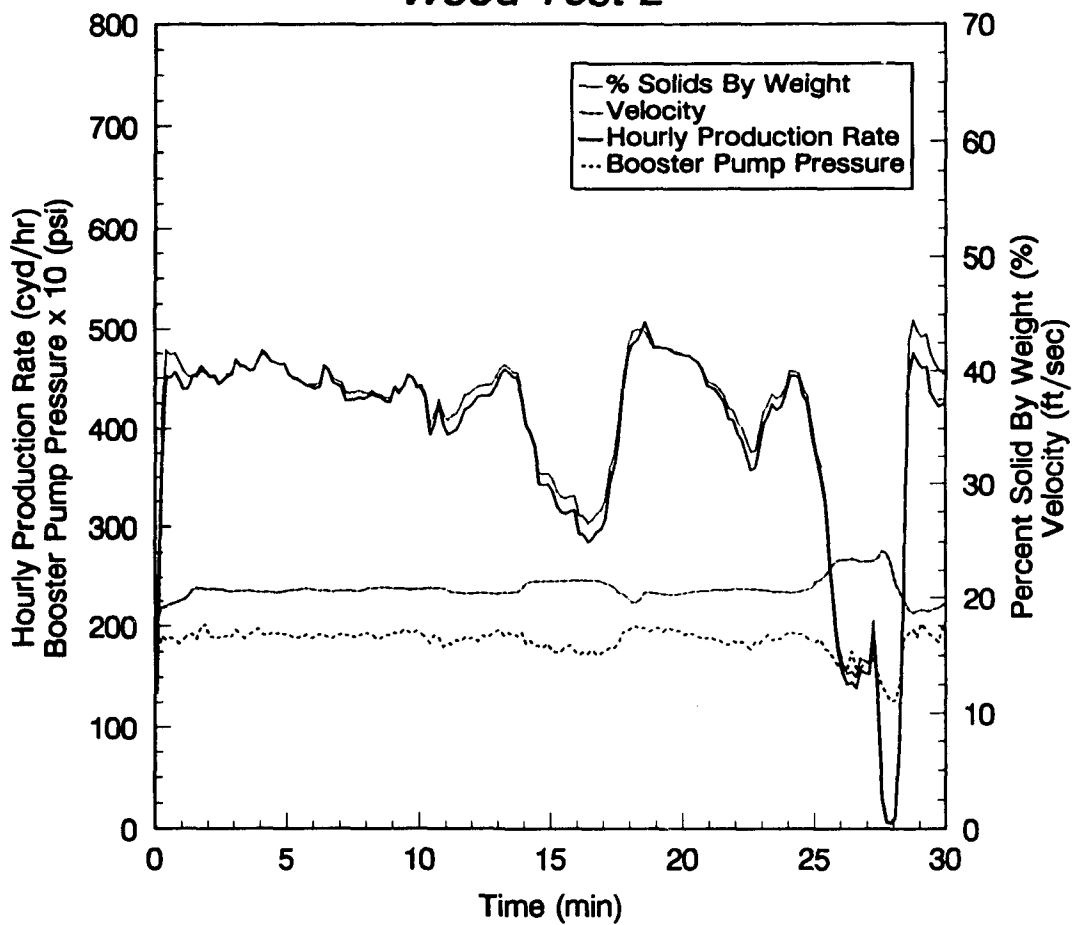

Test Results IR Educator Wood Test 3

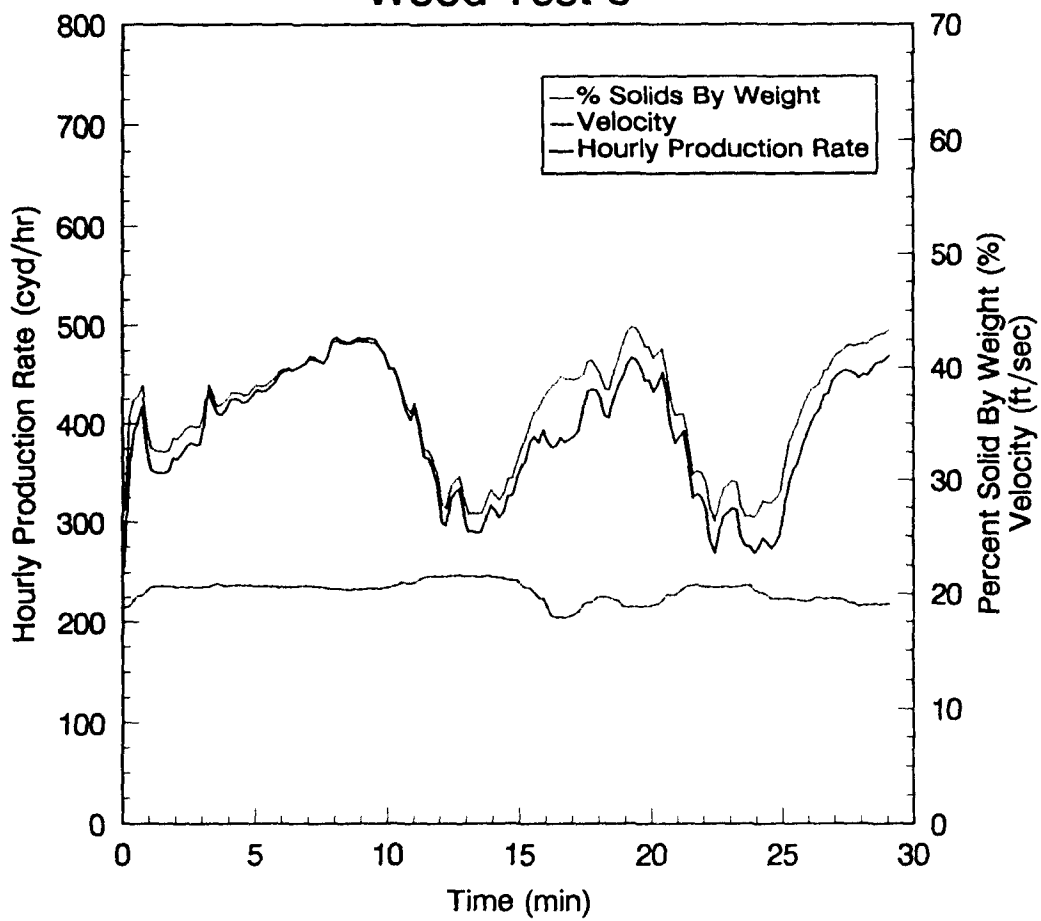

Test Results IR Eductor Riprap Test 1

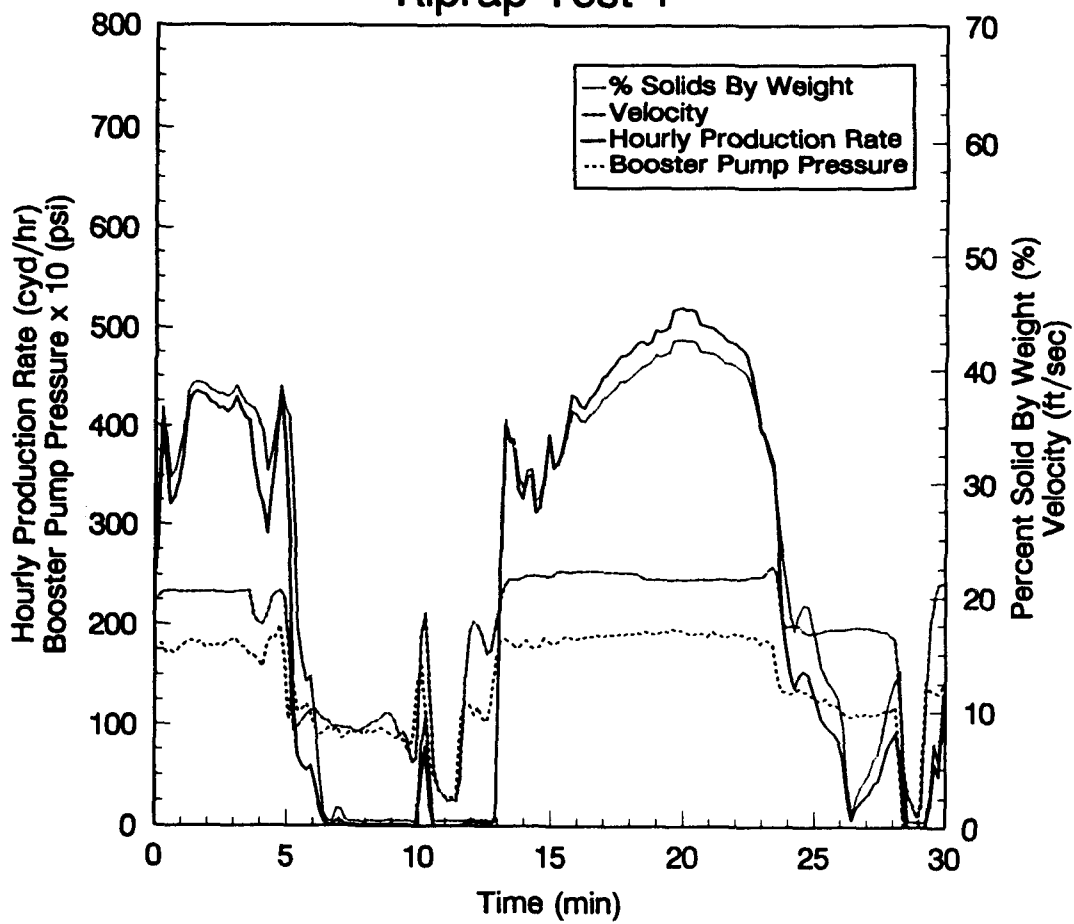

Test Results IR Educator Riprap Test 2

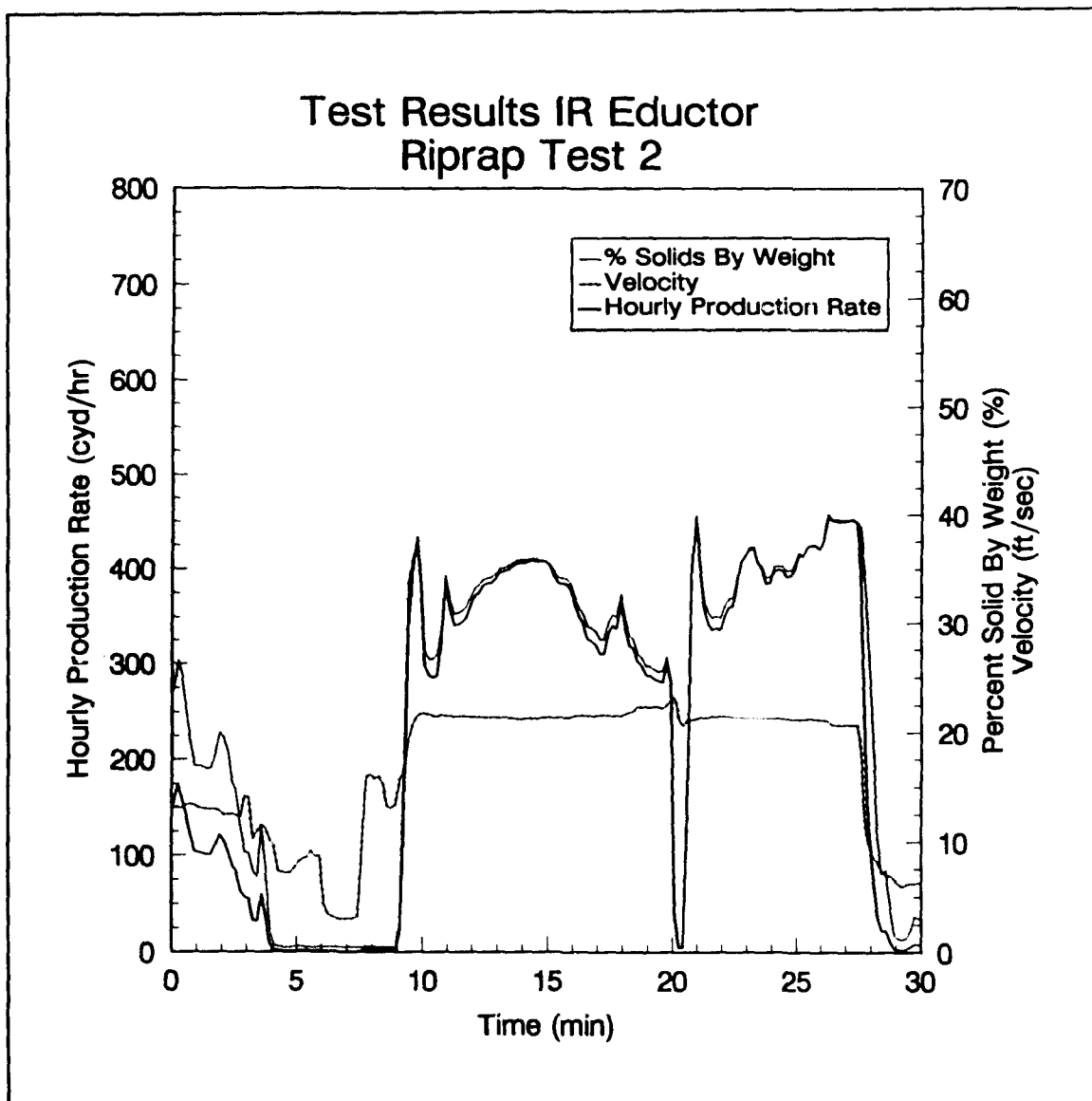

Test Results IR Educator Riprap Test 3

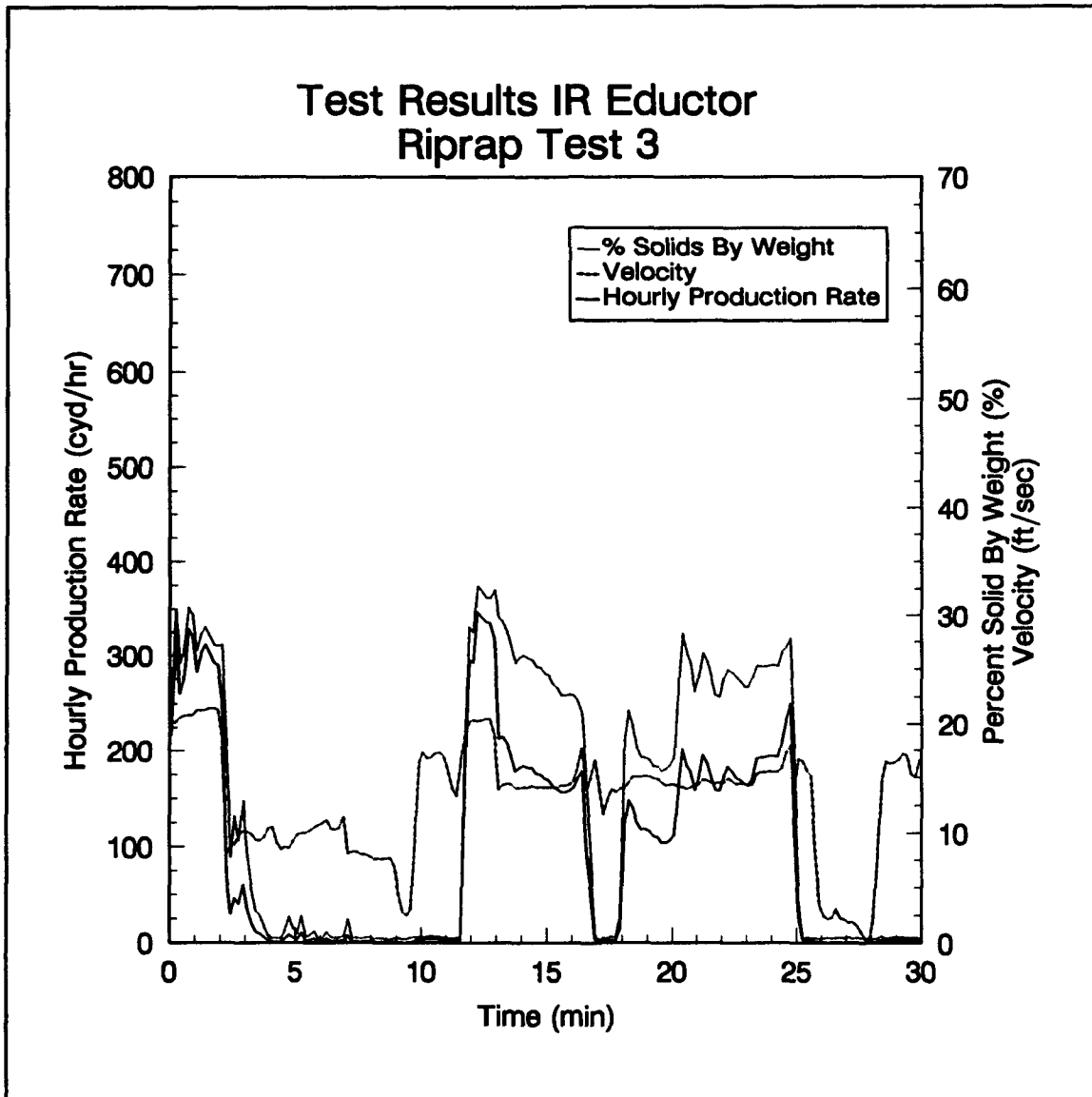

Test Results IR Eductor Clean Sand Test 1

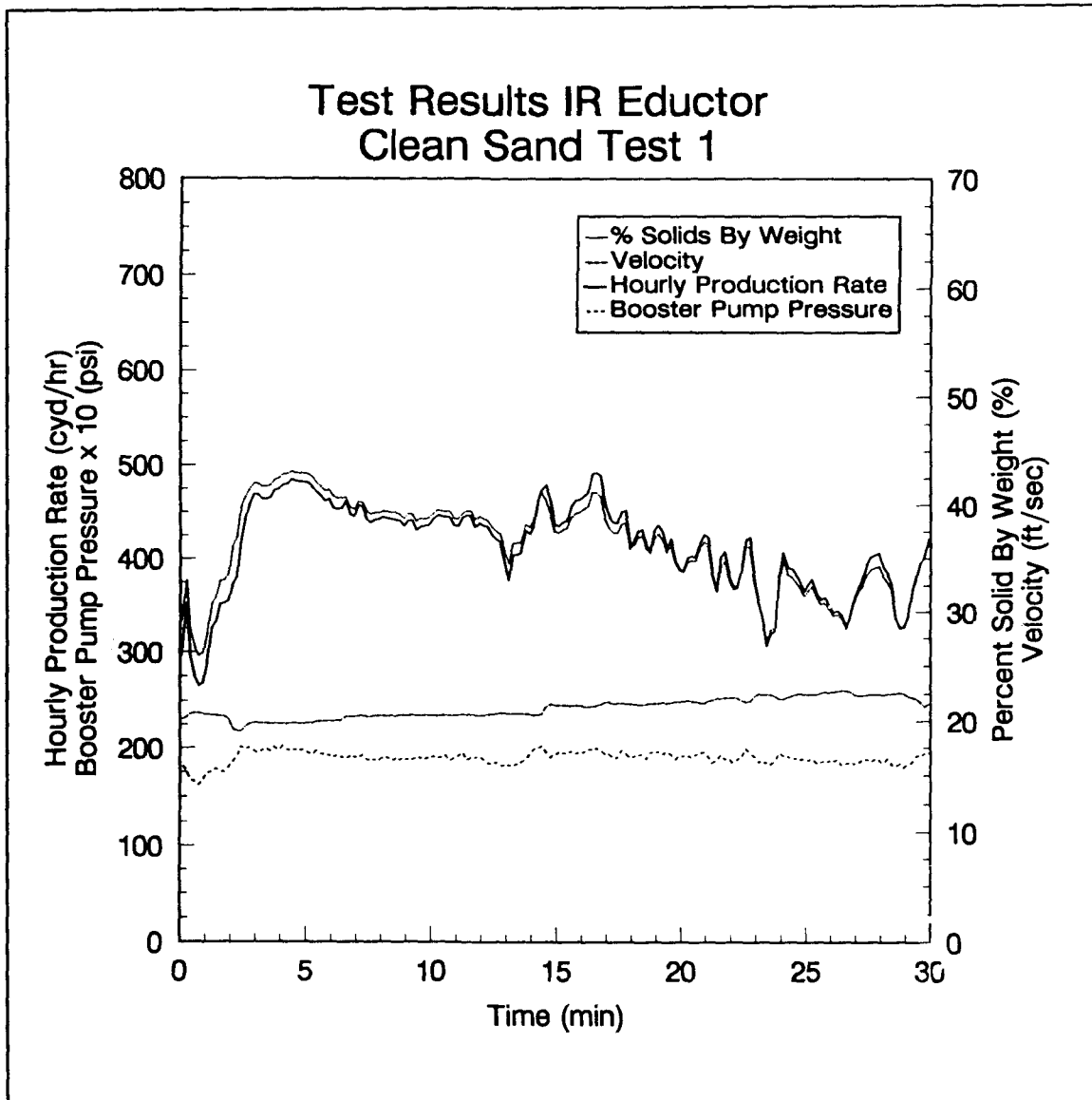

Test Results IR Eductor Clean Sand Test 2

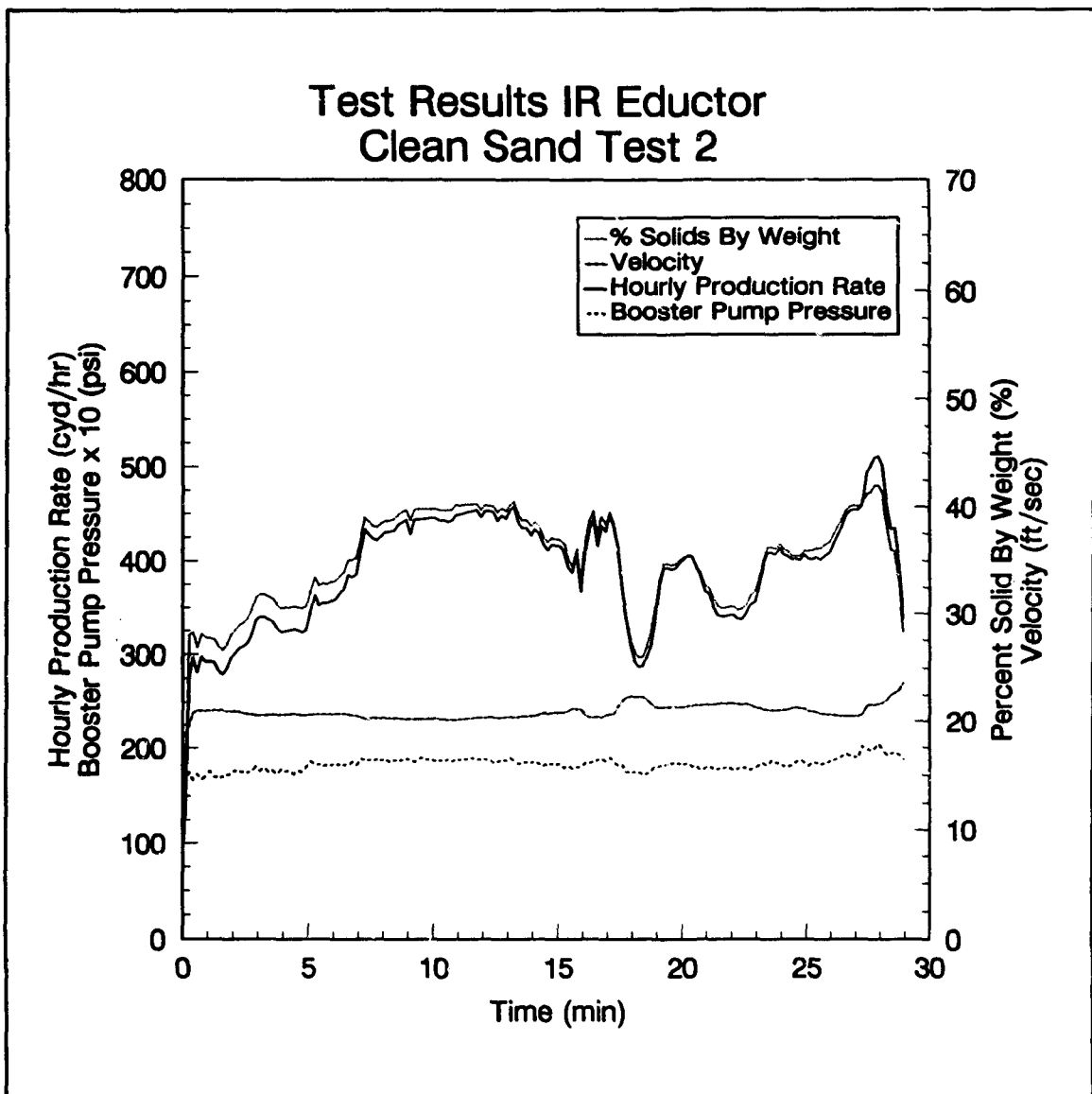

Test Results IR Eductor Clean Sand Test 3

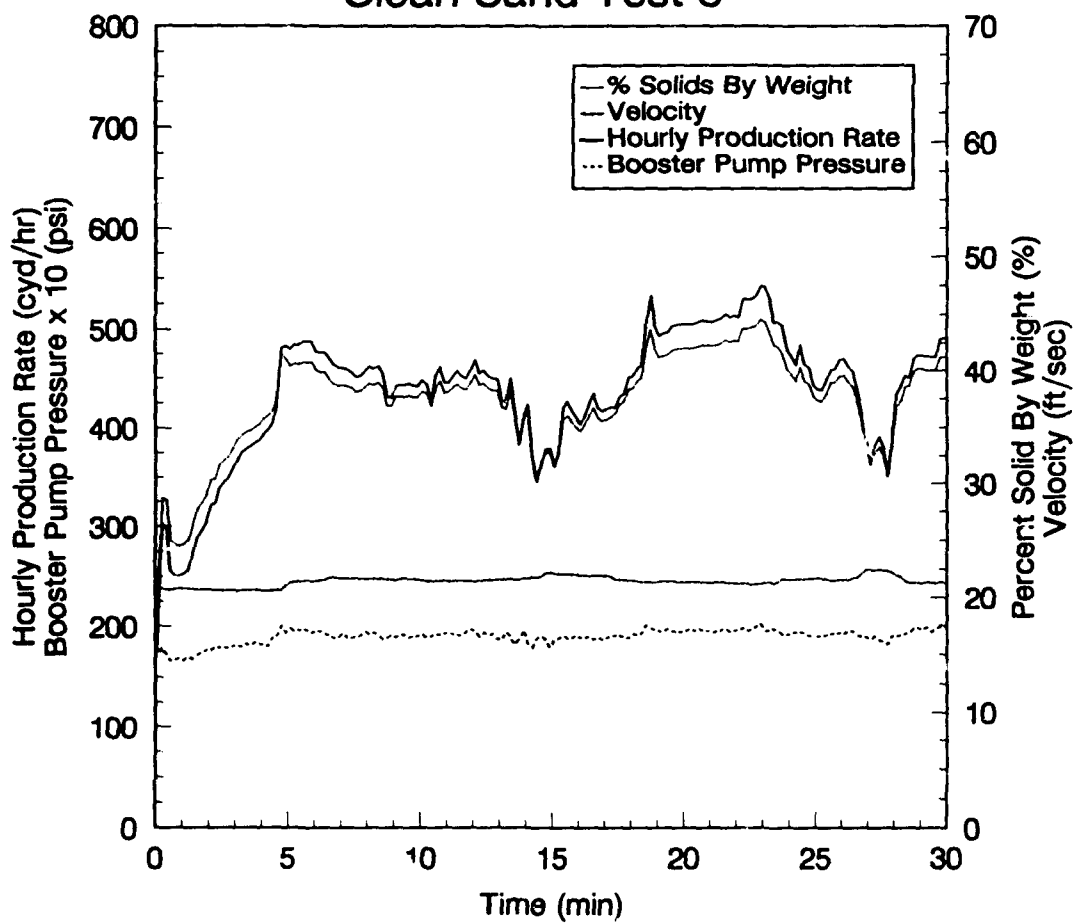

Test Results IR Educator Kelp Test 1

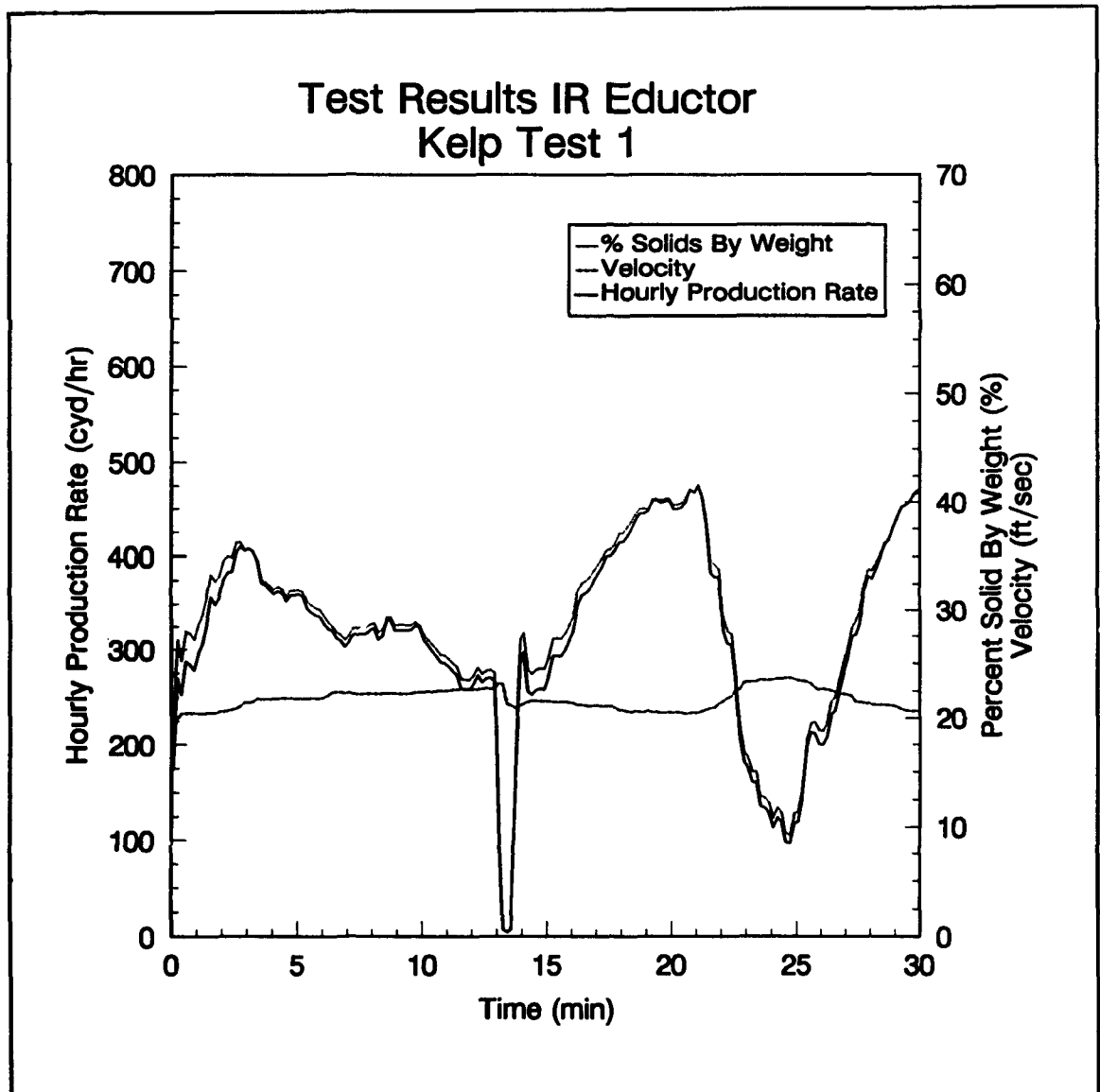

Test Results H & H Submersible Pump Clean Sand Test 1

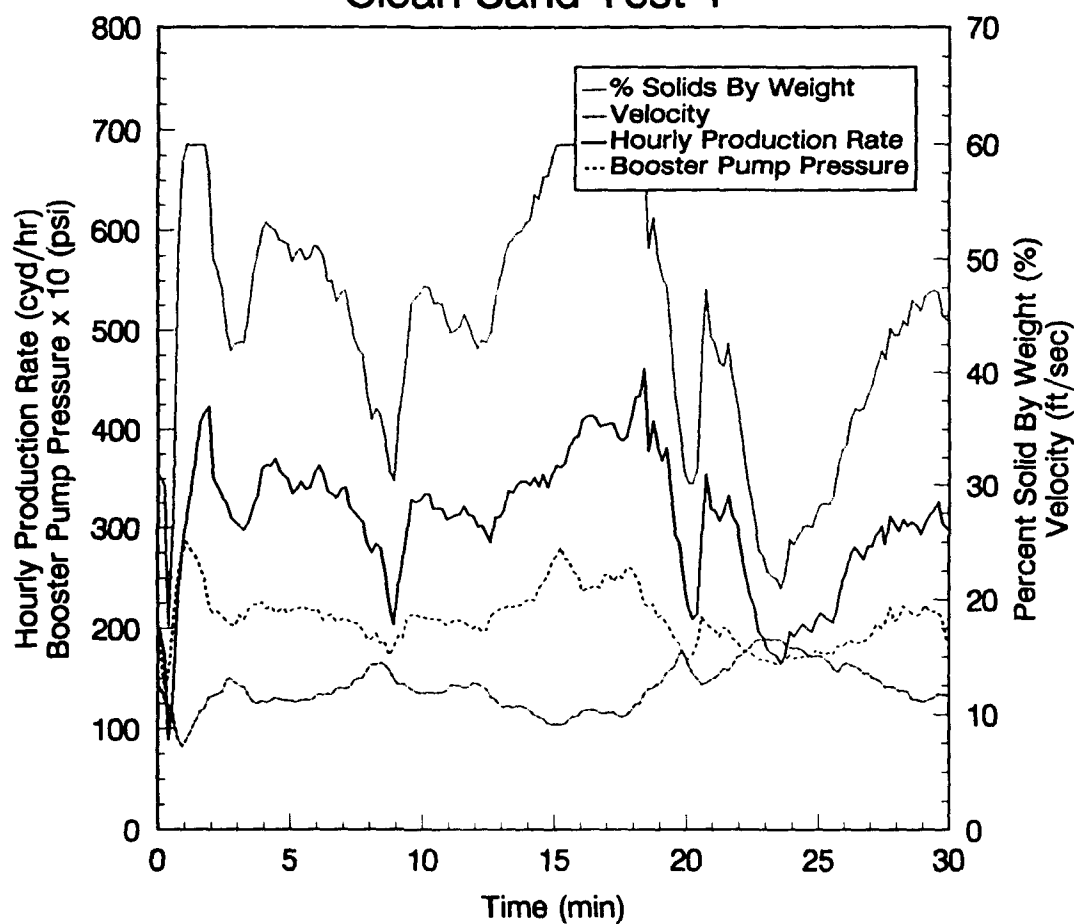

Test Results H & H Submersible Pump Clean Sand Test 2

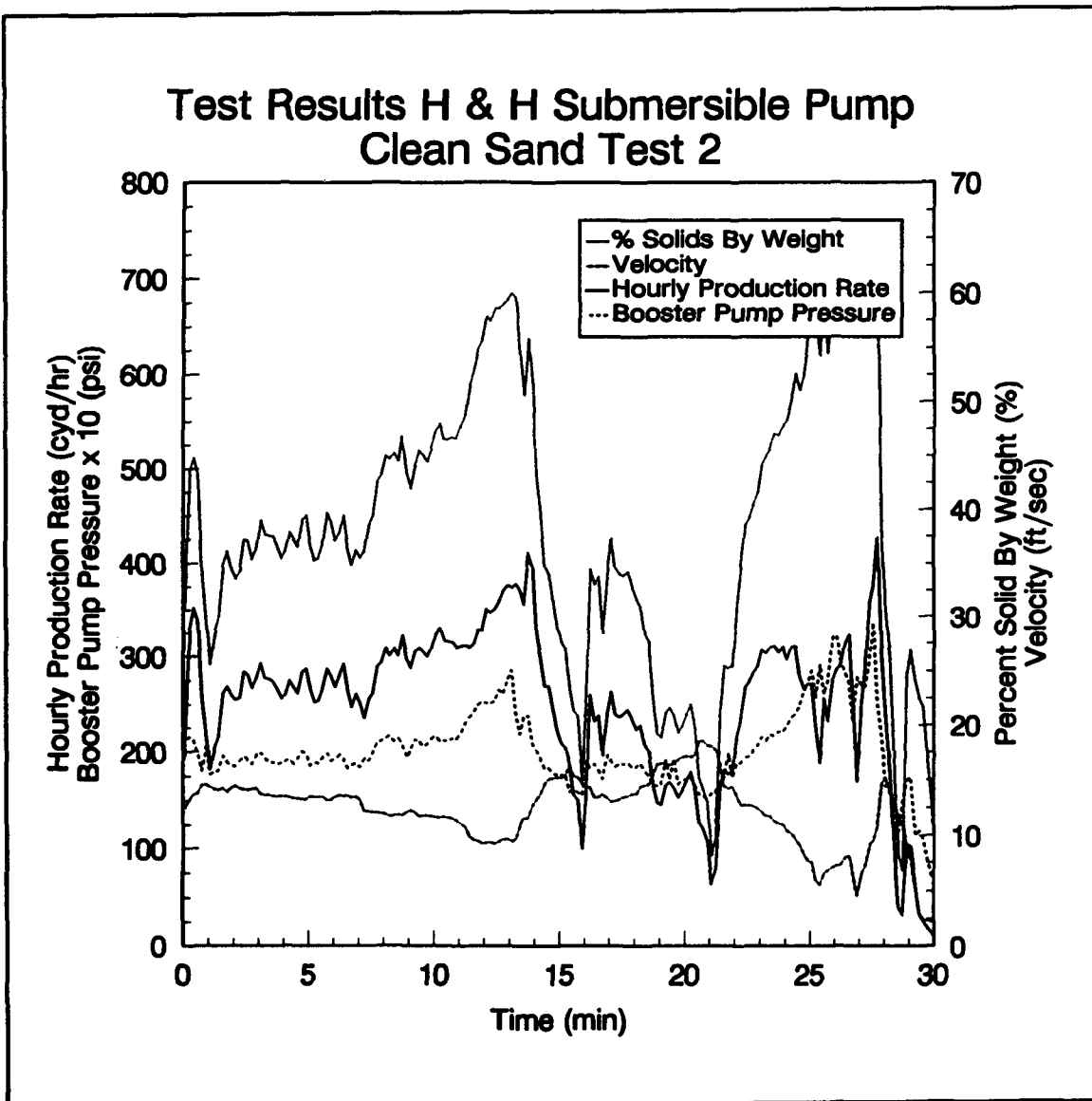

Test Results H & H Submersible Pump Clean Sand Test 3

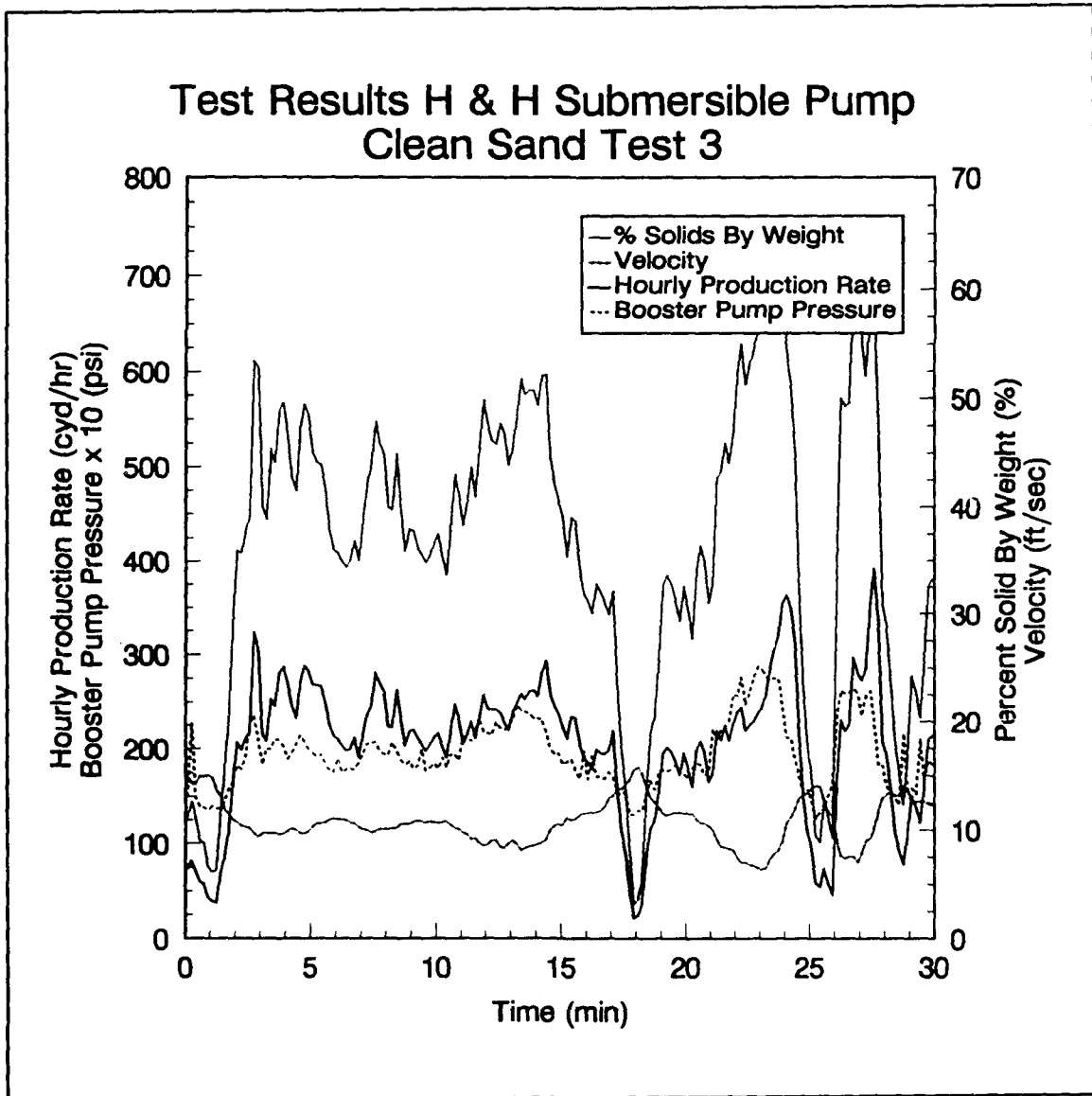

Test Results H & H Submersible Pump Wood Test 1

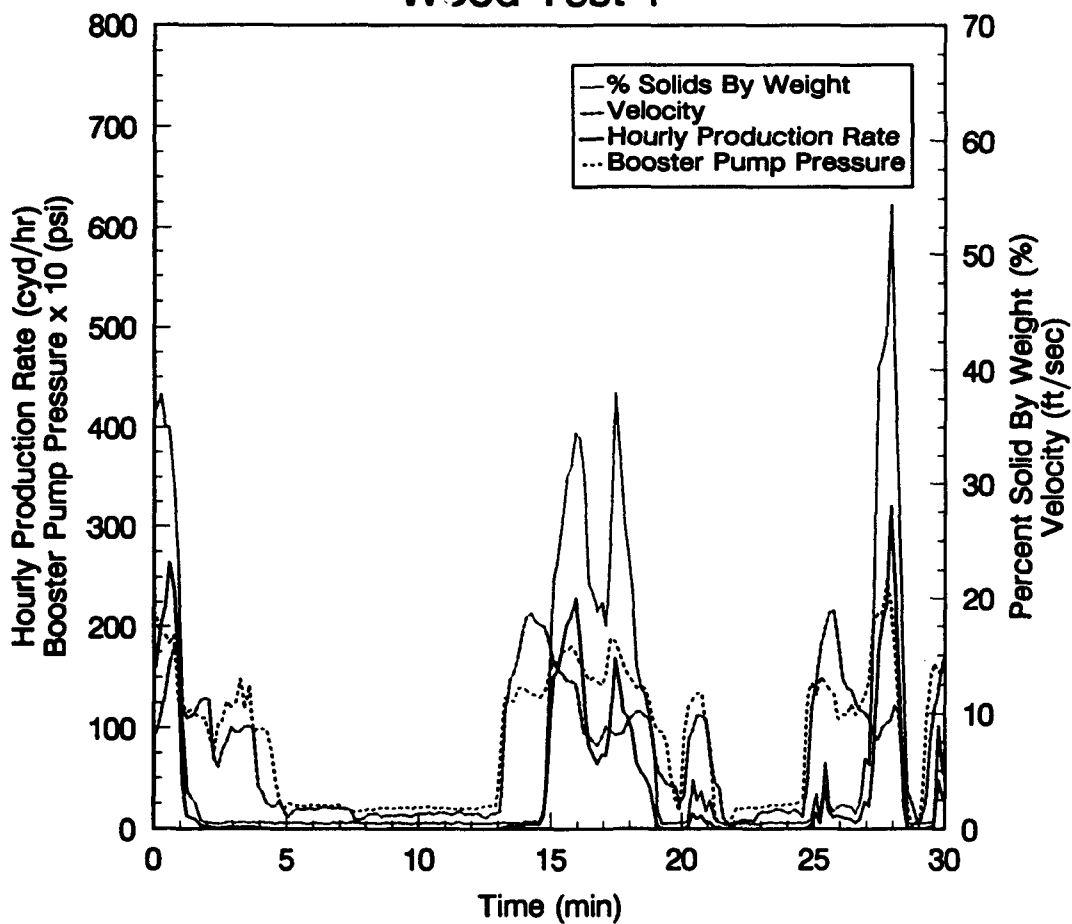

Test Results H & H Submersible Pump Riprap Test 1

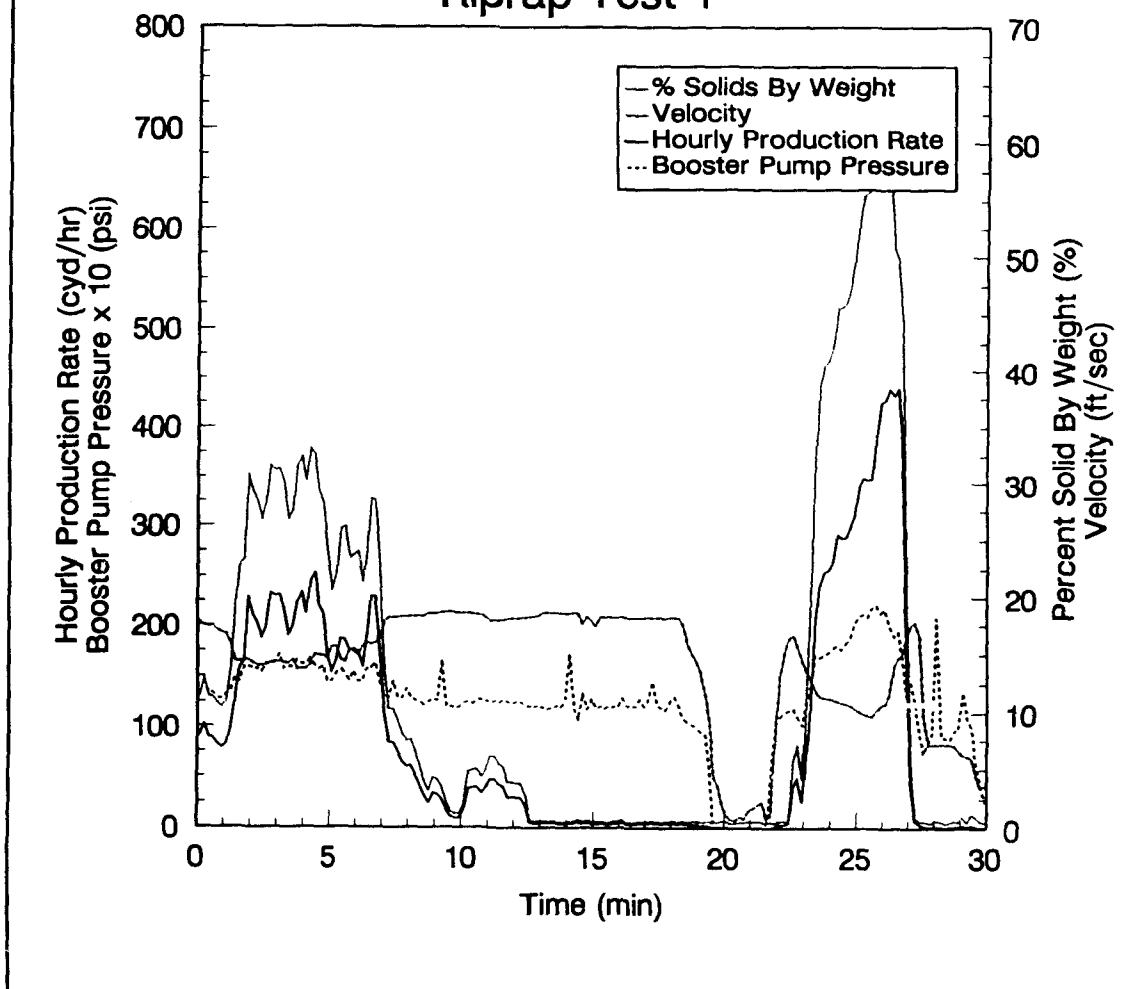

Test Results H & H Submersible Pump Riprap Test 2

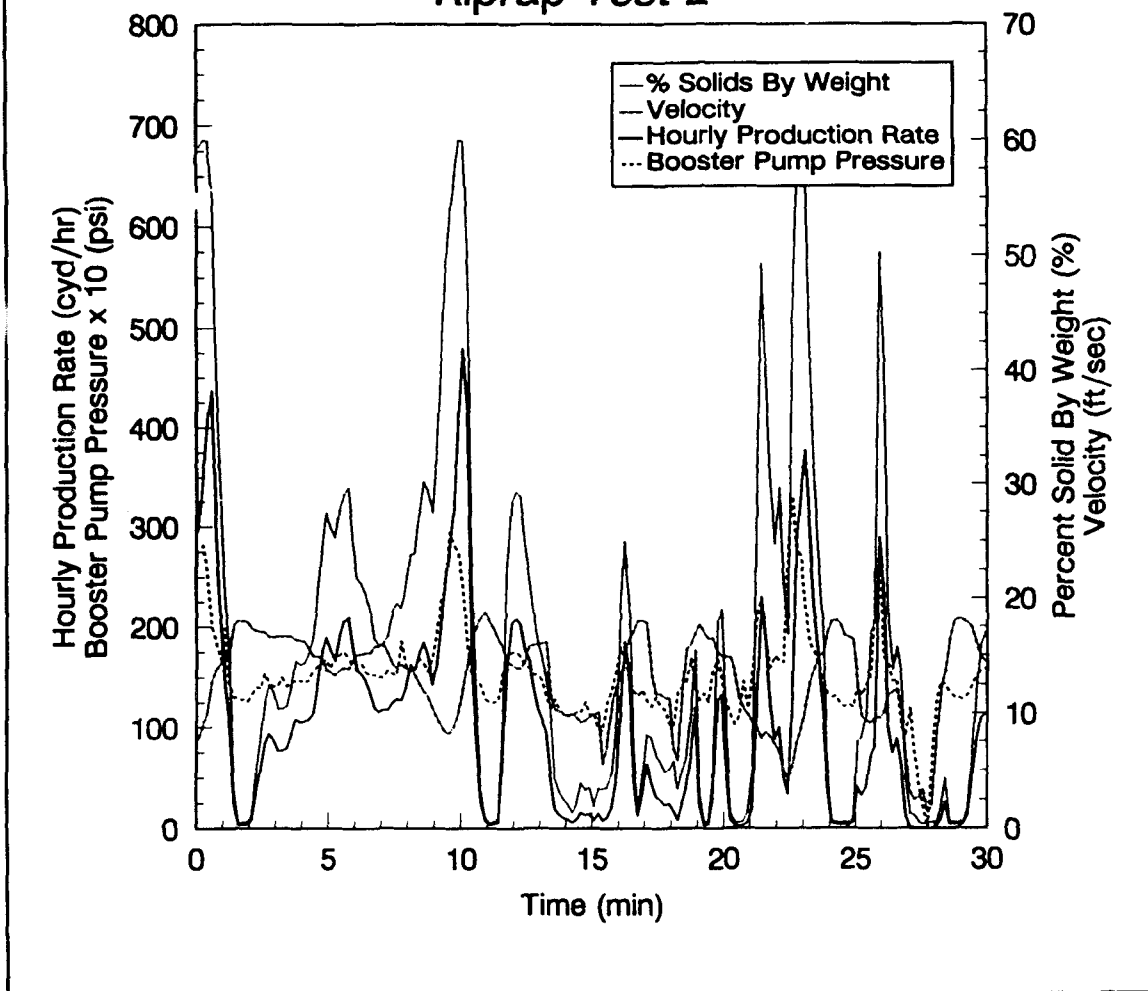

Test Results H & H Submersible Pump Garbage Bags & Swim Fins Test 1

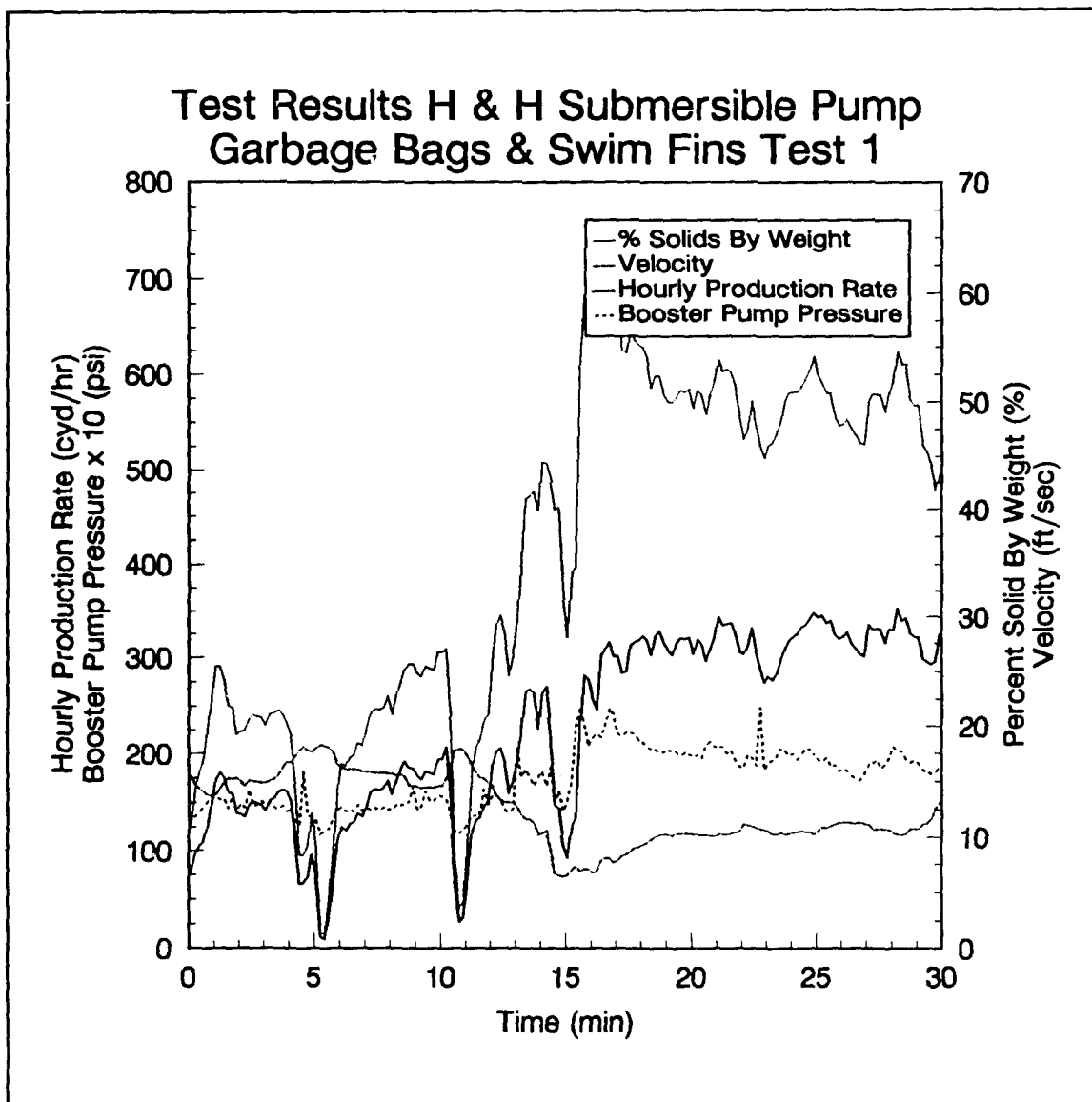

Test Results H & H Submersible Pump Garbage Bags & Swim Fins Test 2

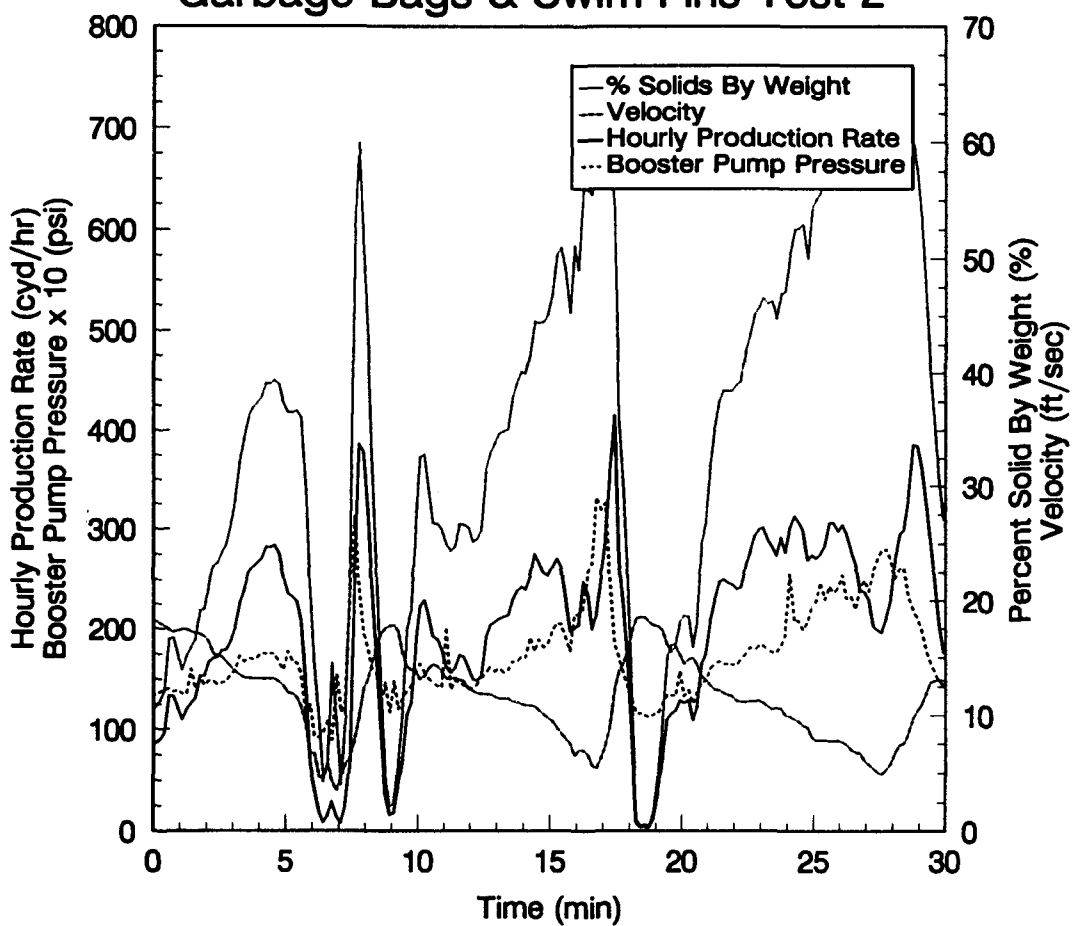

Test Results TOYO Submersible Pump Clean Sand Test 1

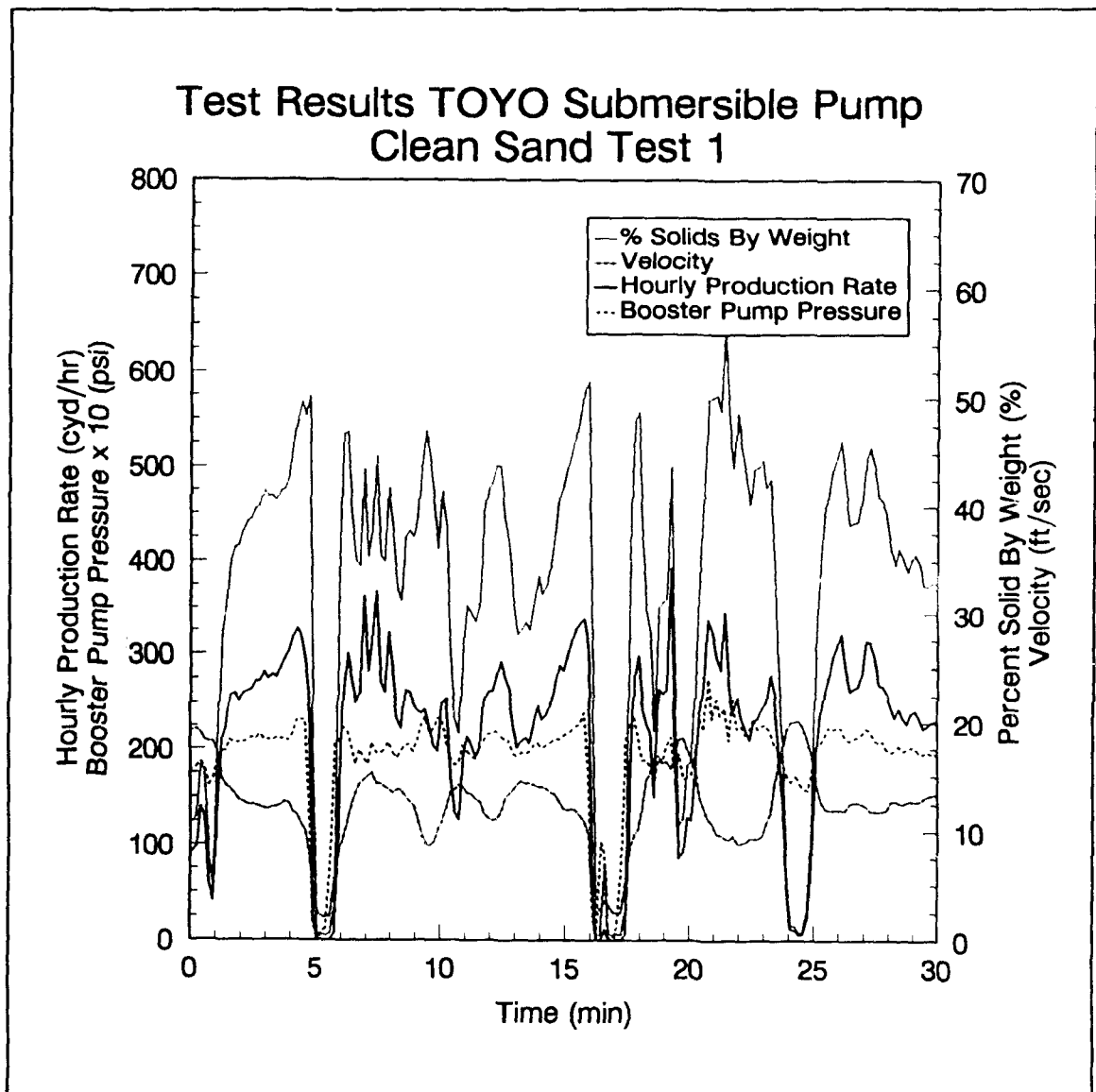

Test Results TOYO Submersible Pump Clean Sand Test 2

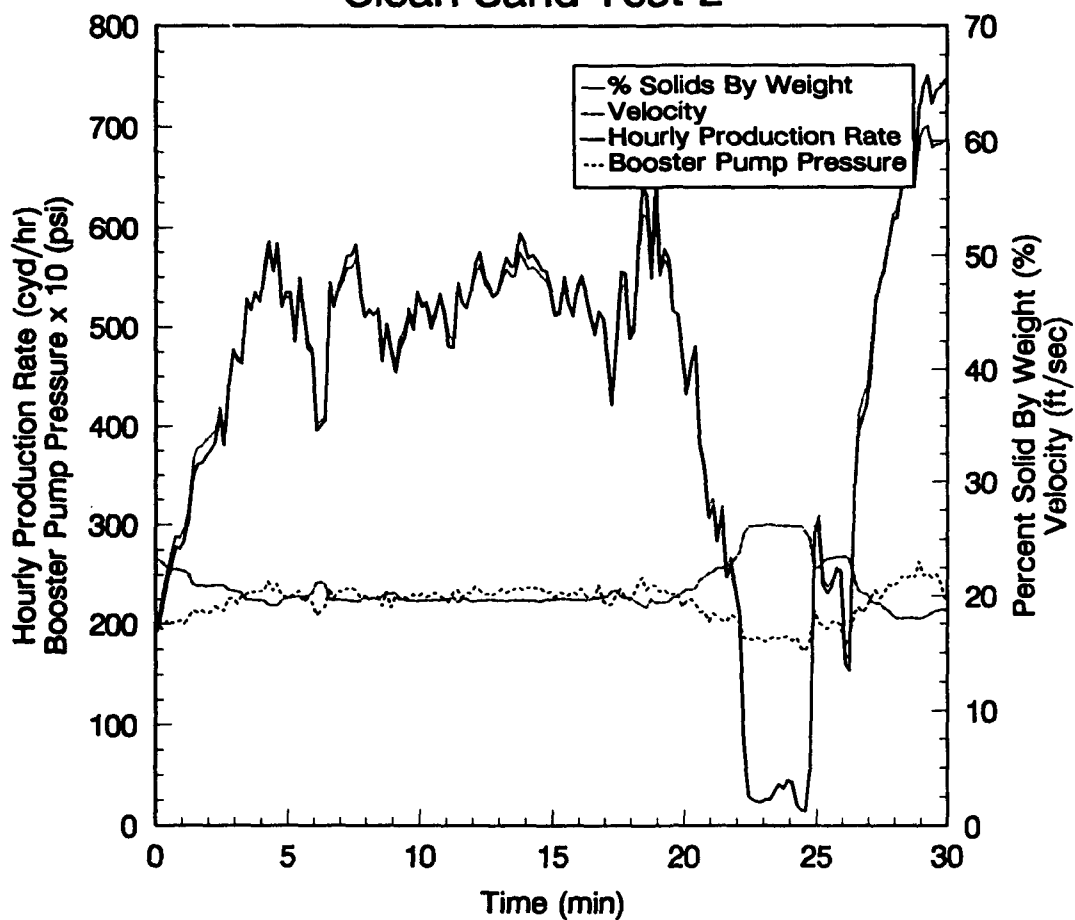

Test Results TOYO Submersible Pump Garbage Bags & Swim Fins Test 1

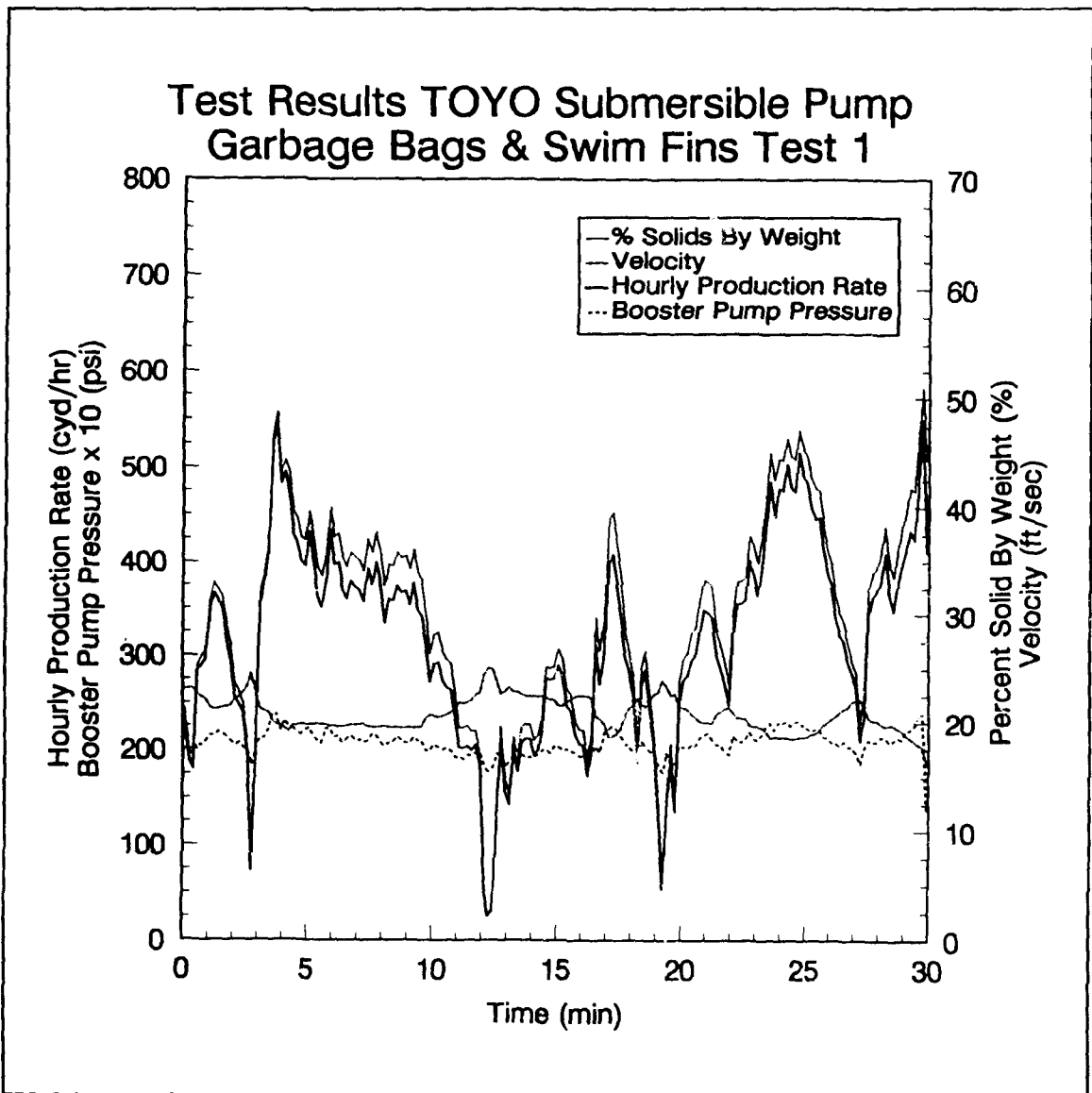

Test Results TOYO Submersible Pump Garbage Bags & Swim Fins Test 2

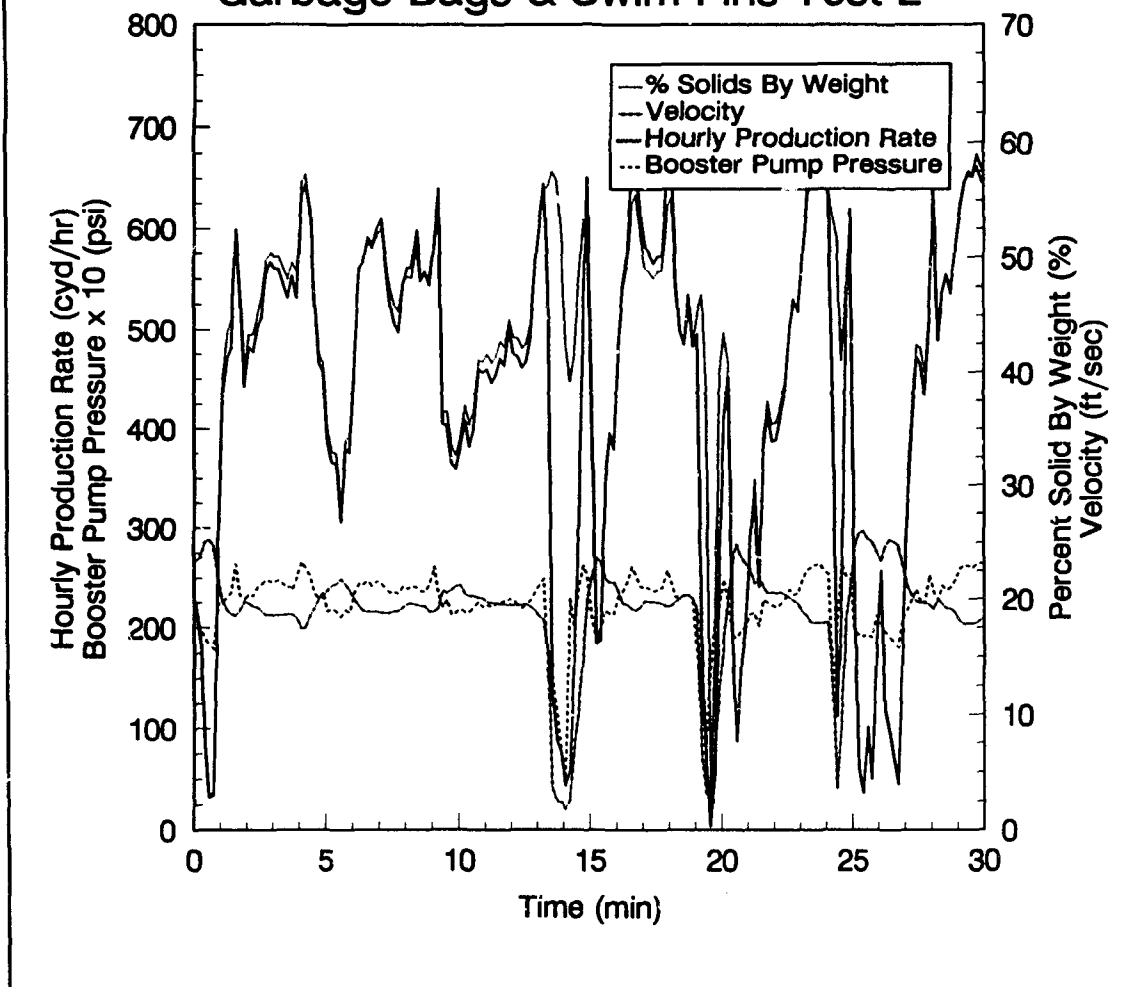

Test Results TOYO Submersible Pump Garbage Bags & Swim Fins Test 3

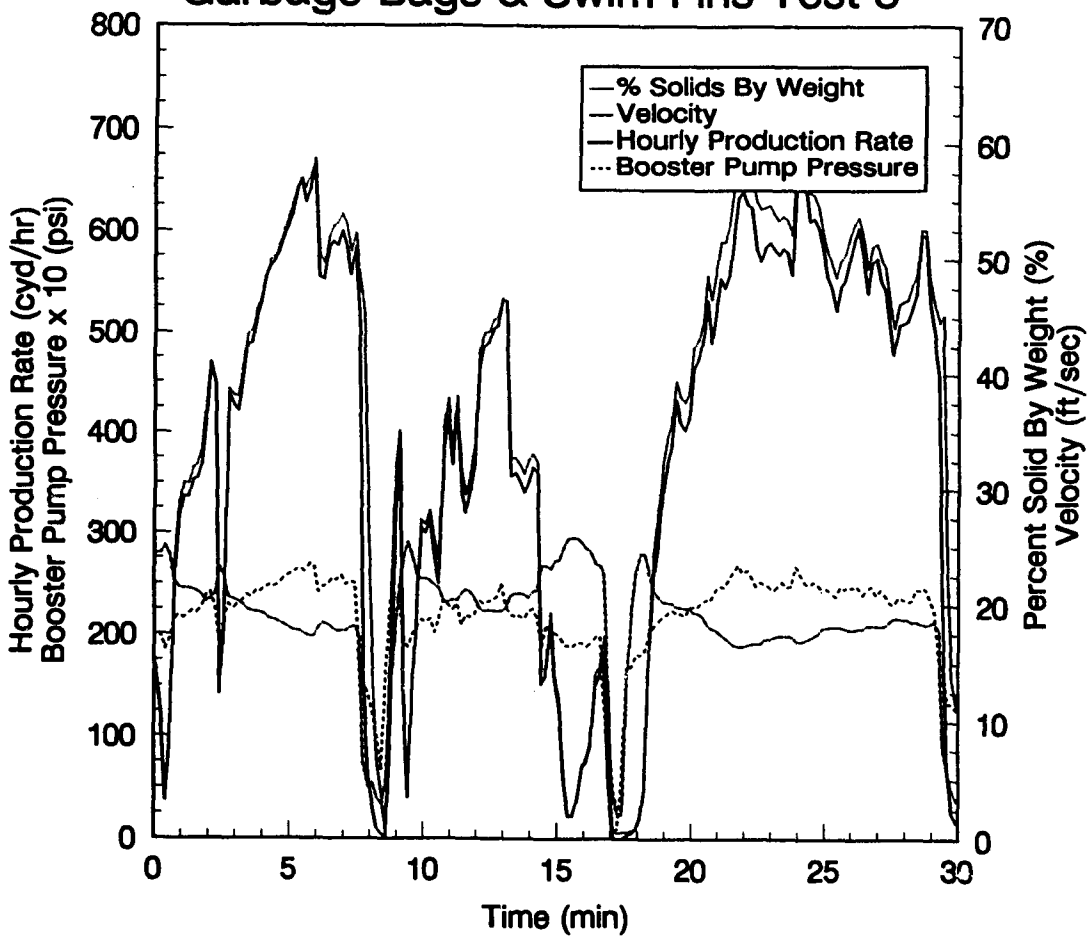

Test Results TOYO Submersible Pump Wood Test 1

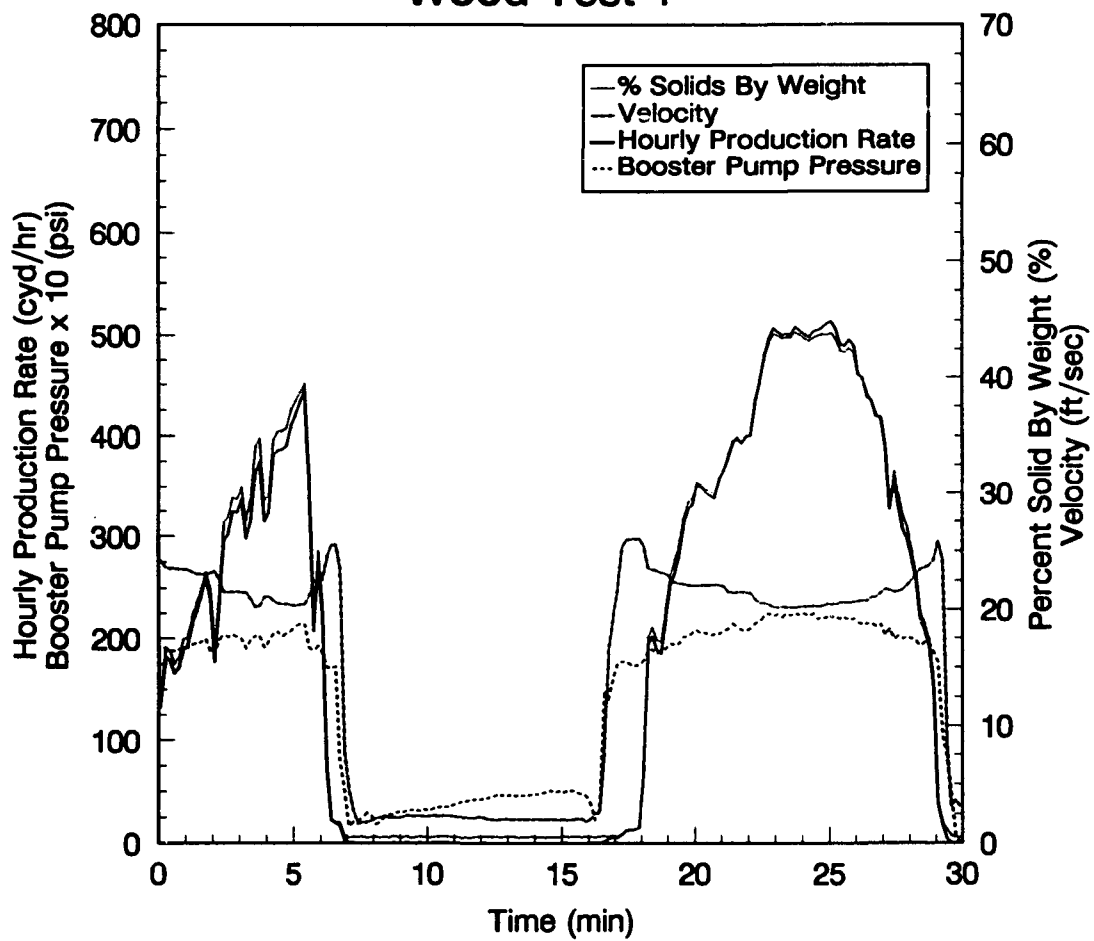

Test Results TOYO Submersible Pump Wood Test 2

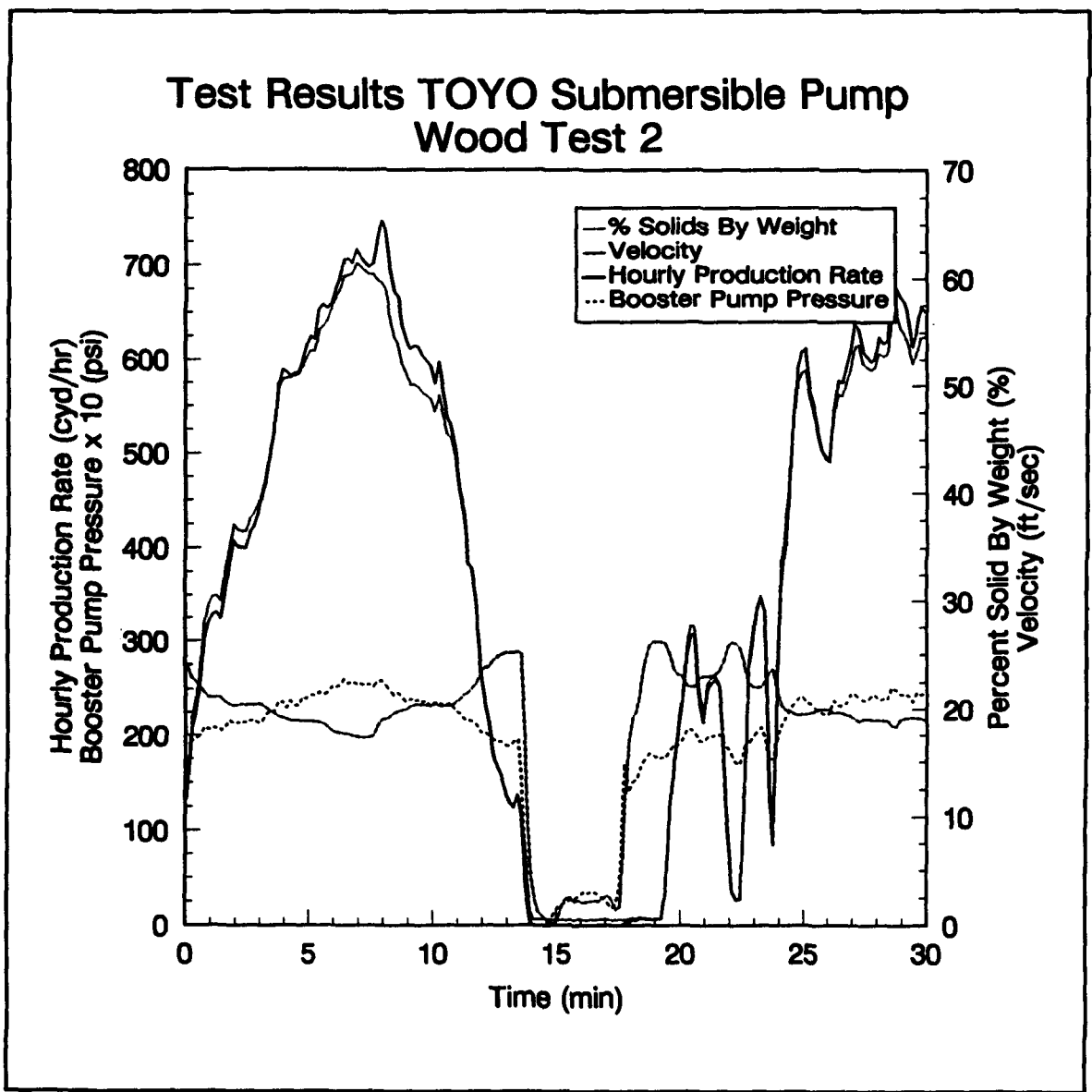

Test Results TOYO Submersible Pump Riprap Test 1

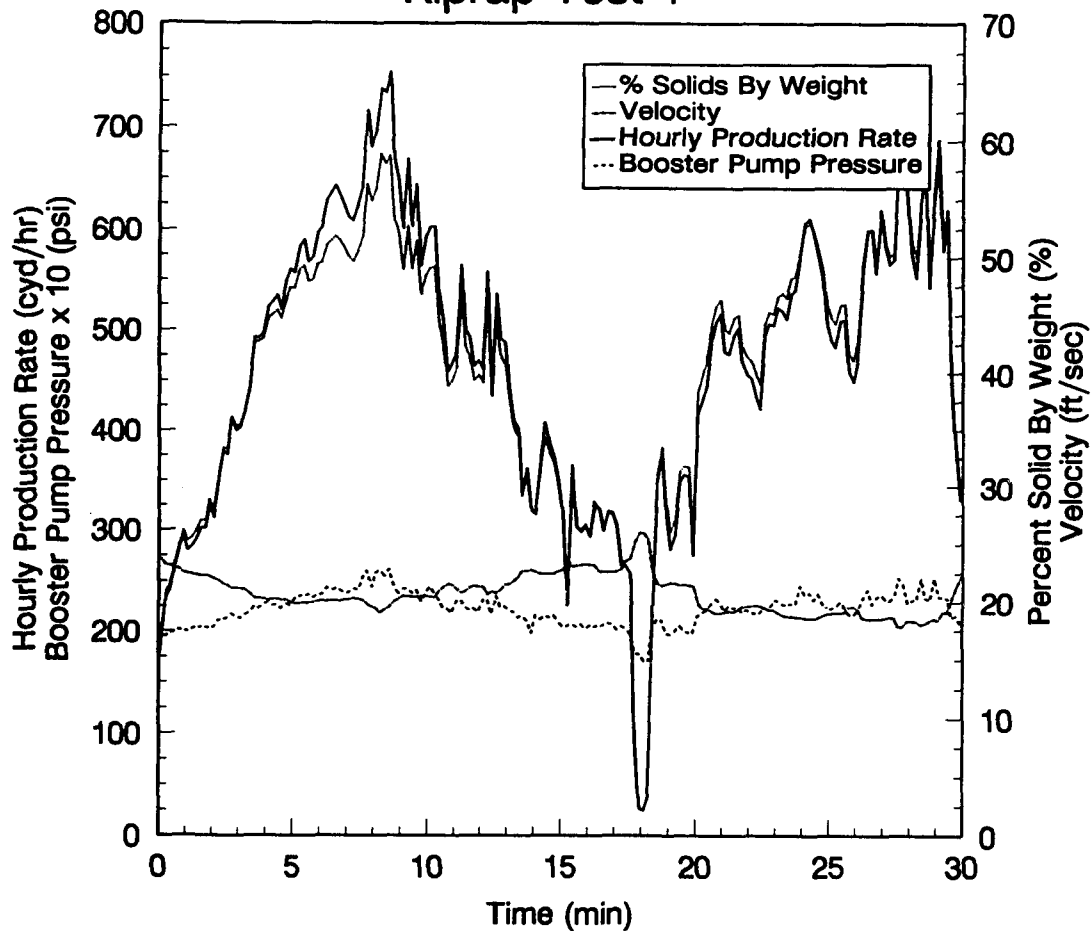

Test Results TOYO Submersible Pump Riprap Test 2

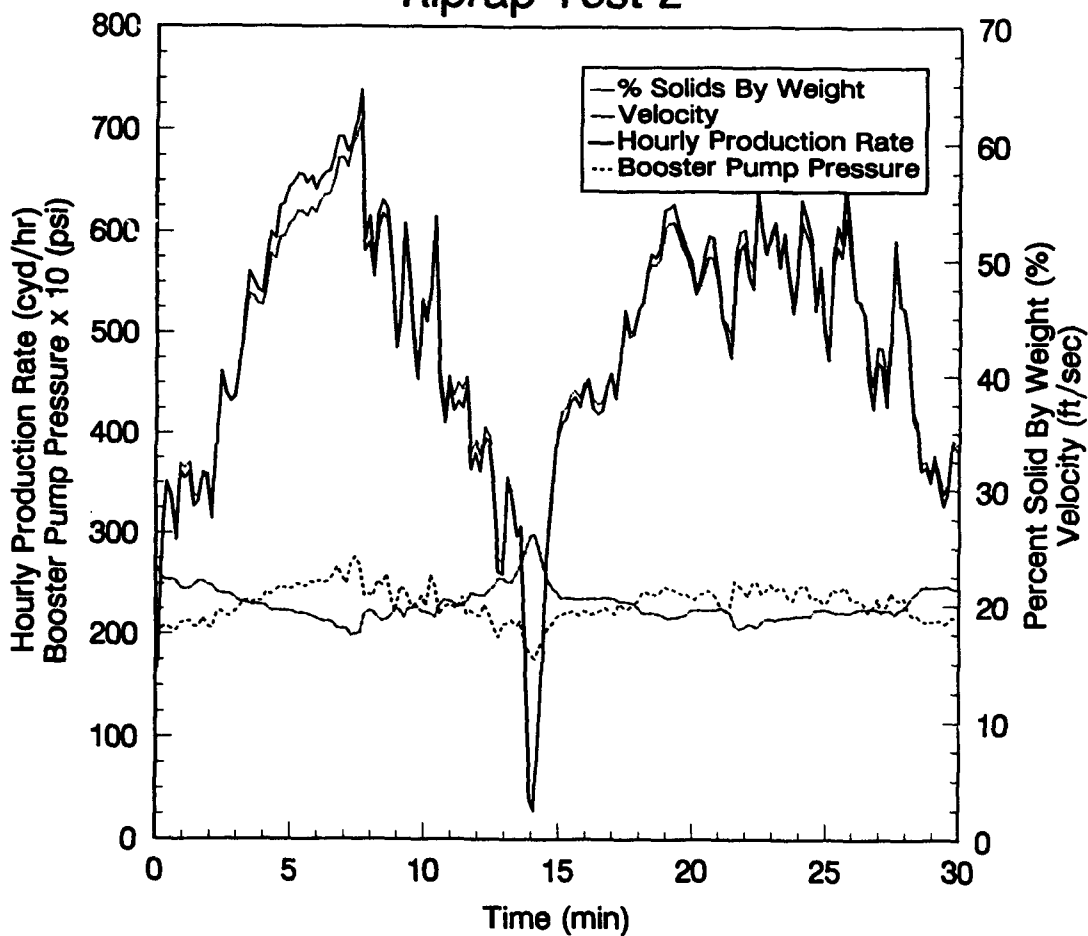

Hourly Production Rate One Minute Averages

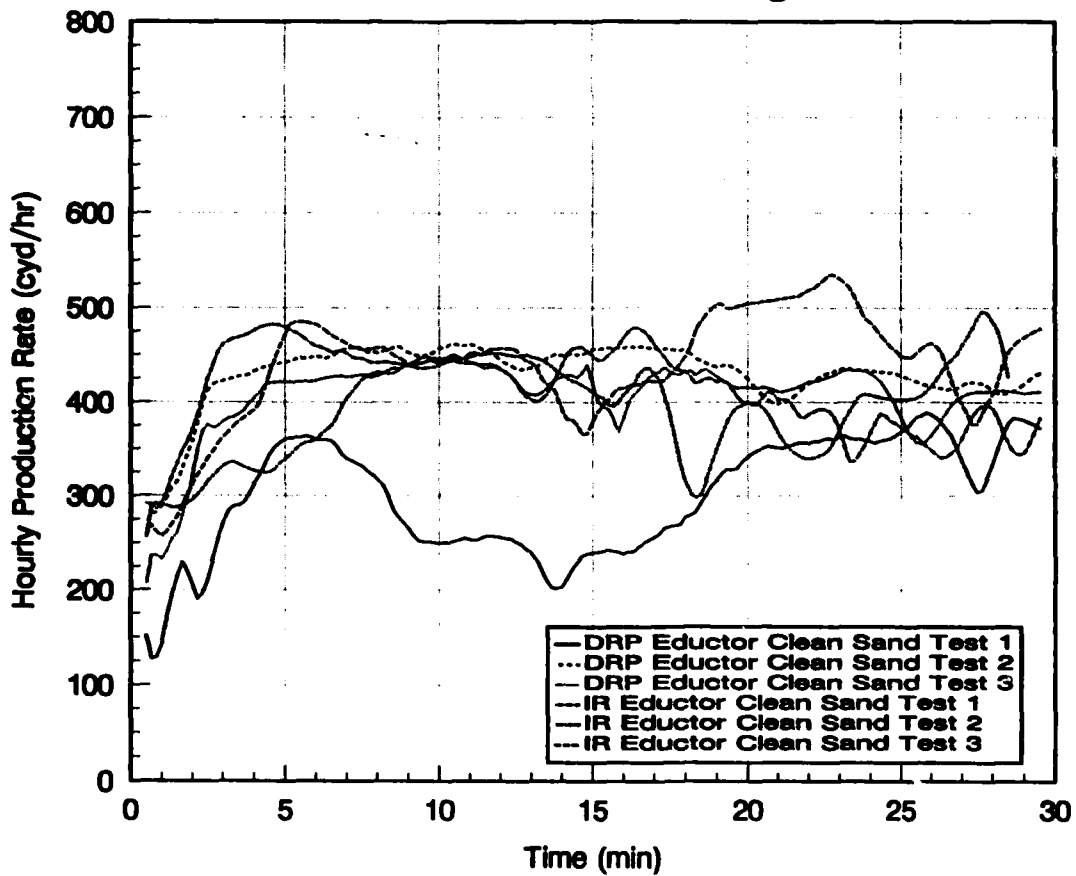

Hourly Production Rate One Minute Averages

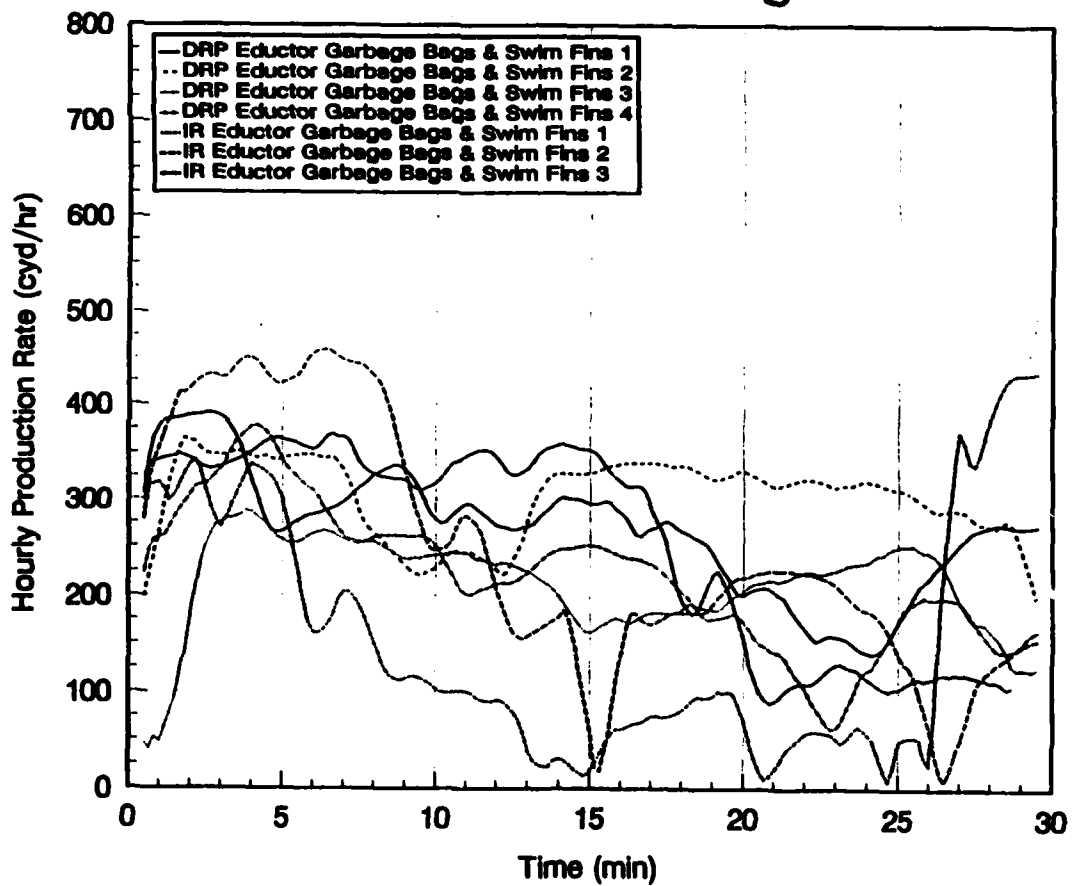

Hourly Production Rate One Minute Averages

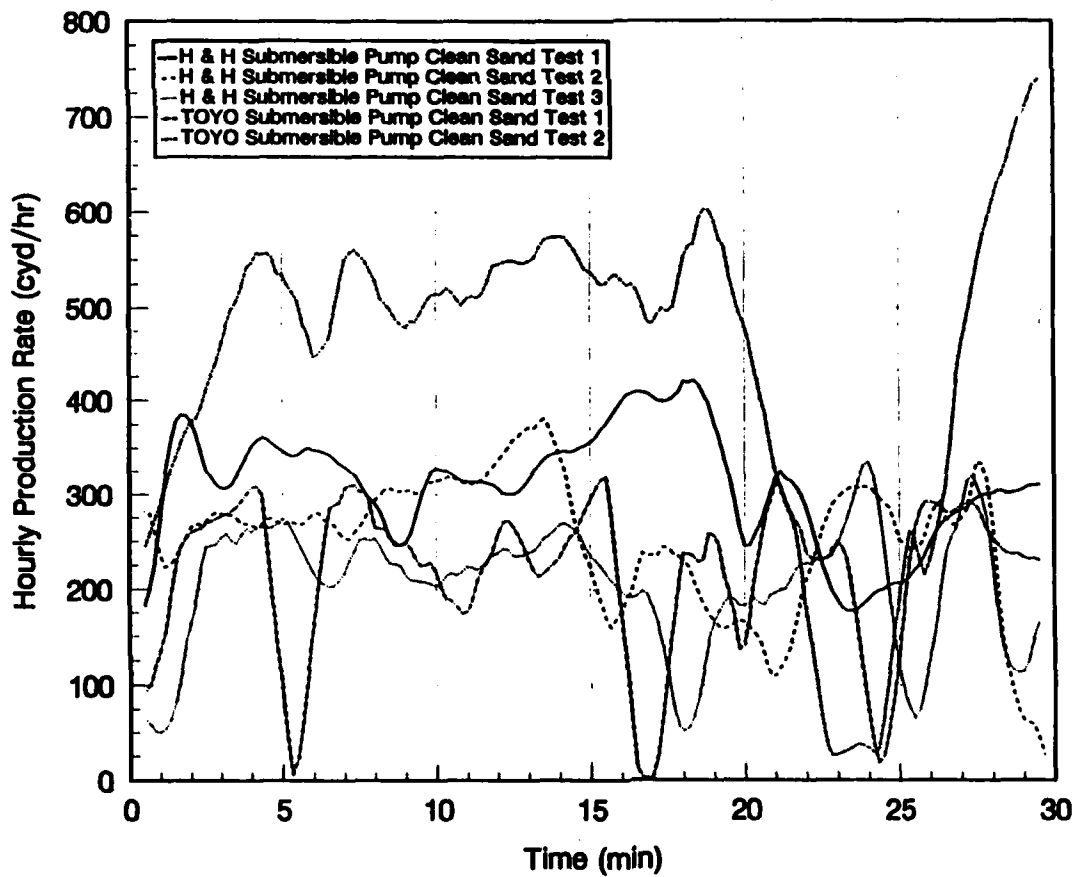

Hourly Production Rate One Minute Averages

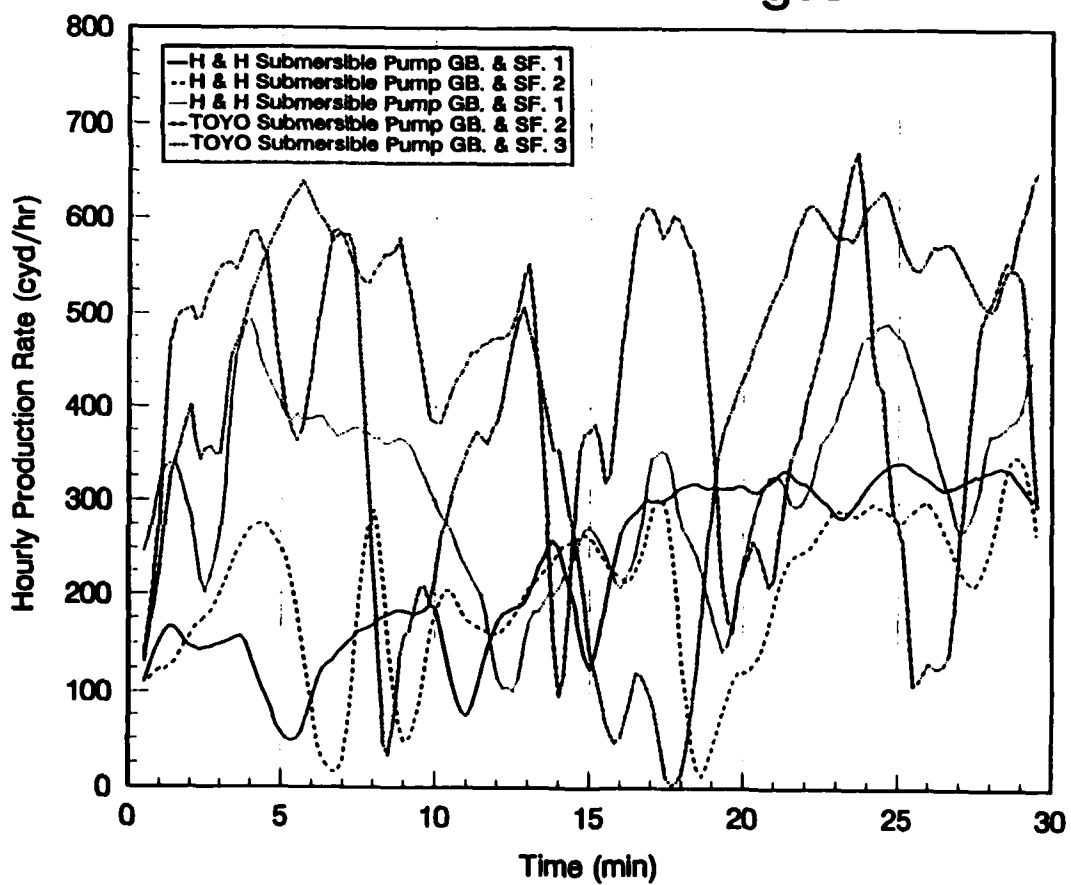

Hourly Production Rate One Minute Averages

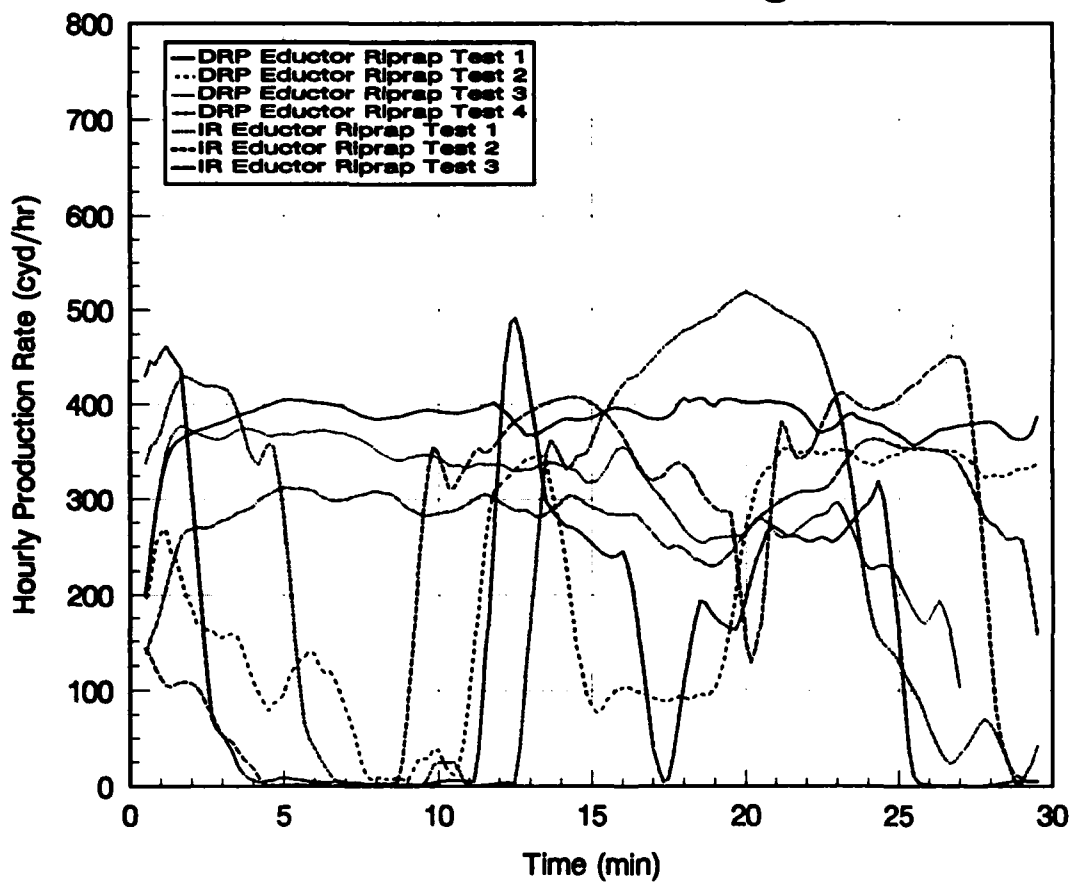

Hourly Production Rate One Minute Averages

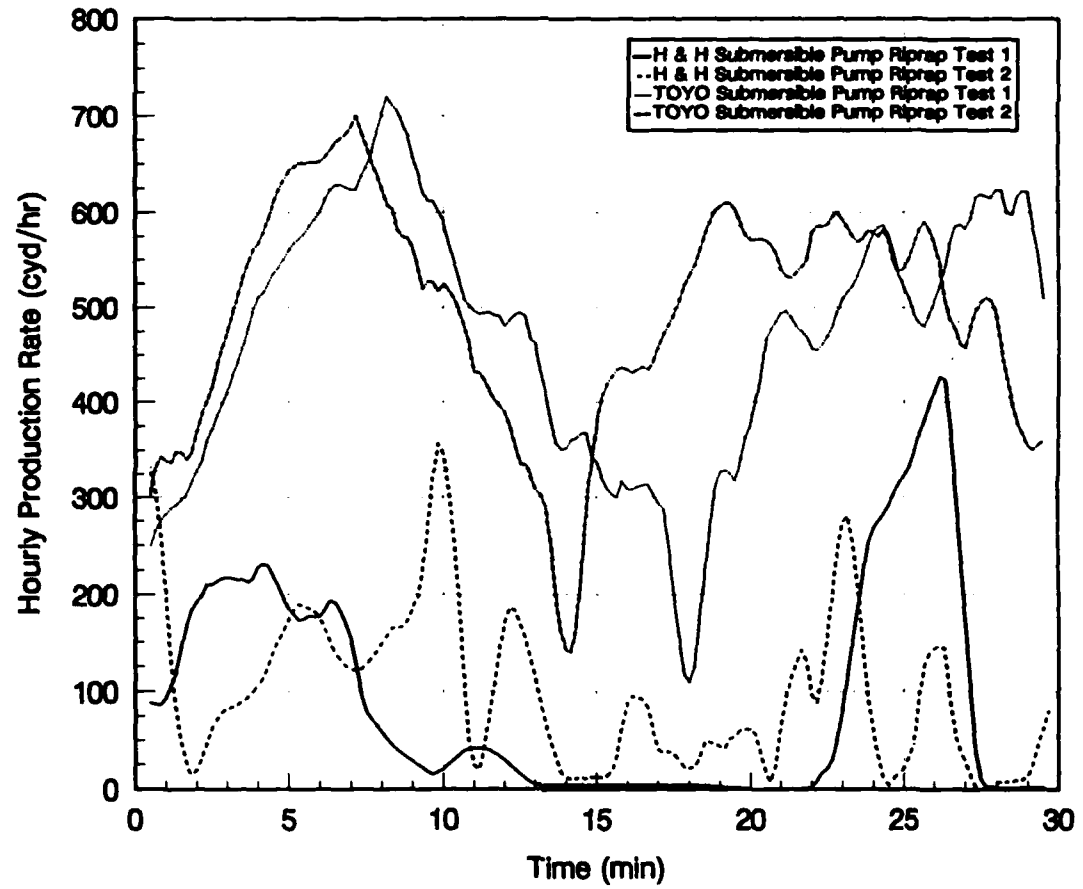

Hourly Production Rate One Minute Averages

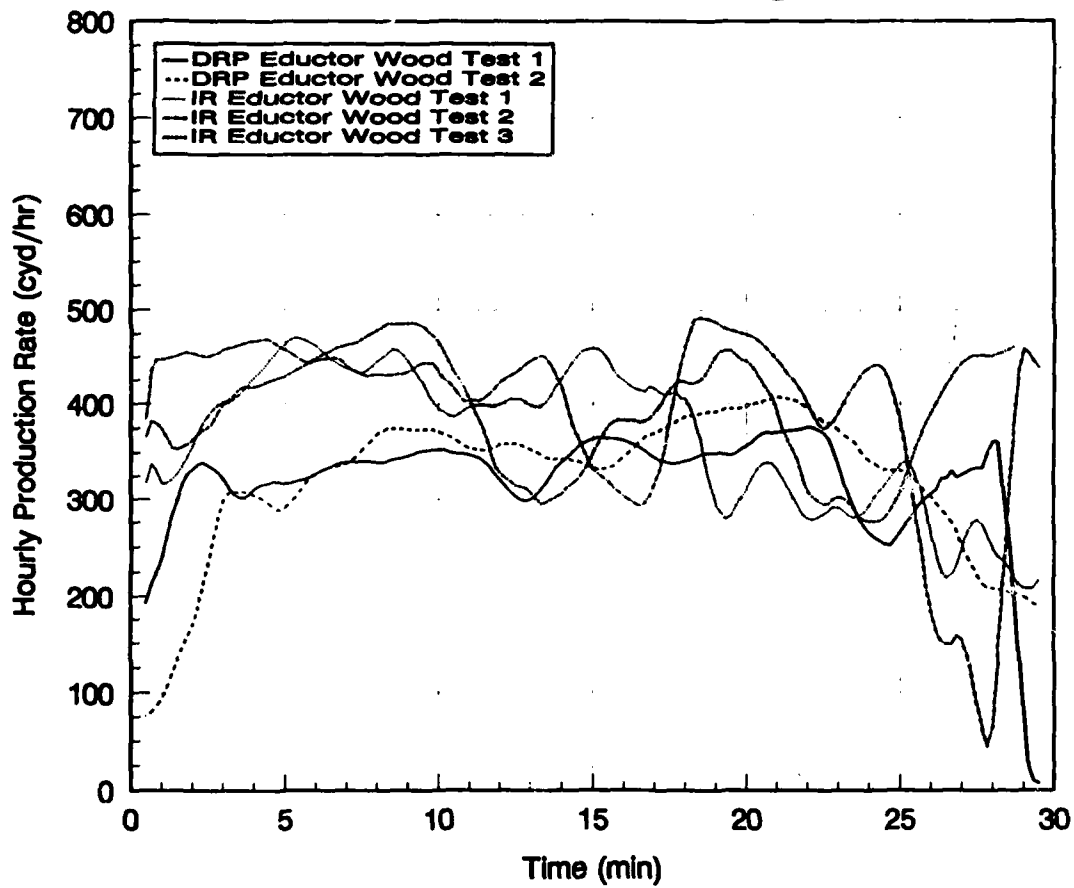

Hourly Production Rate One Minute Averages

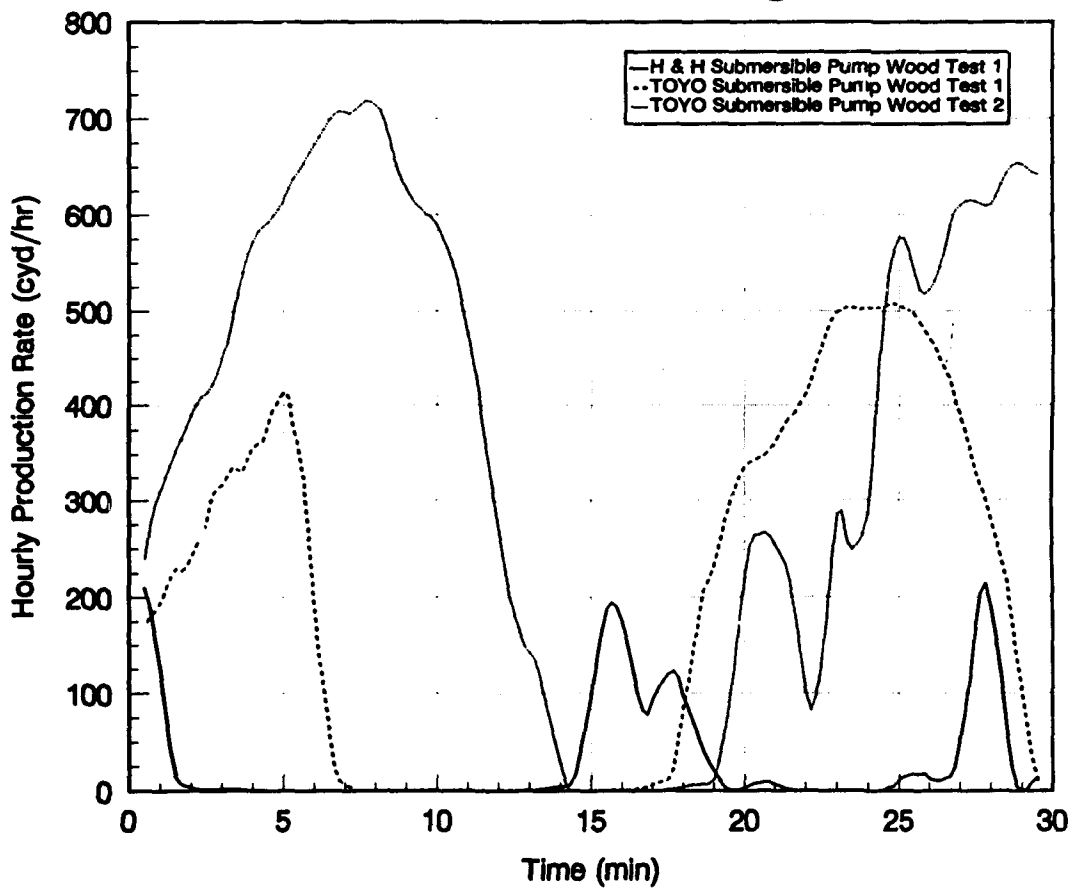

Hourly Production Rate Five Minute Averages

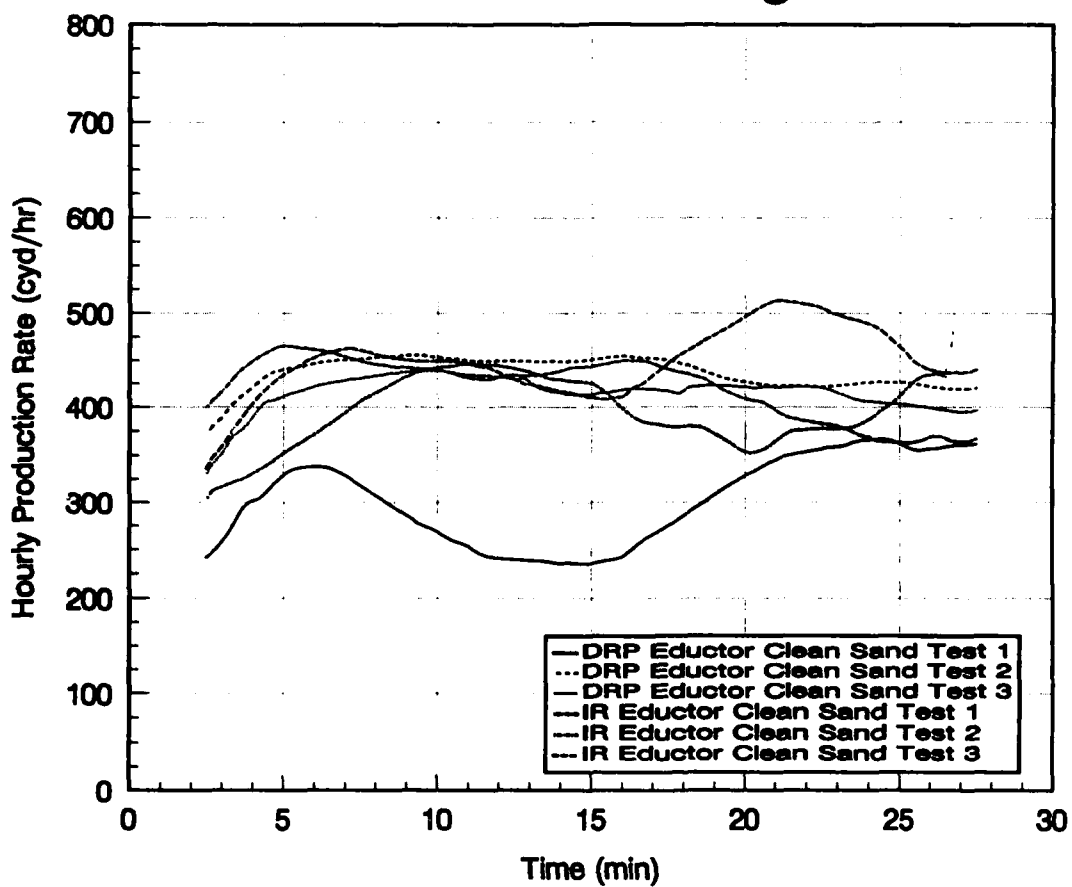

Hourly Production Rate Five Minute Averages

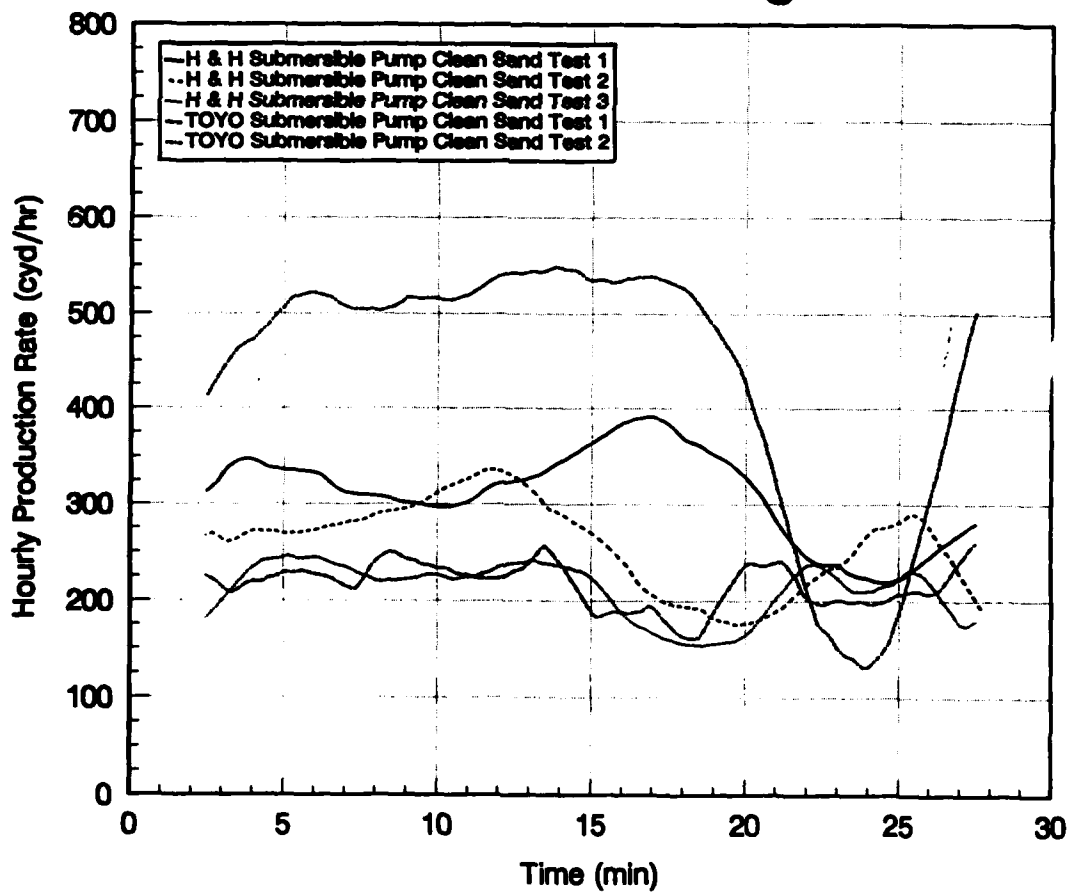

Hourly Production Rate Five Minute Averages

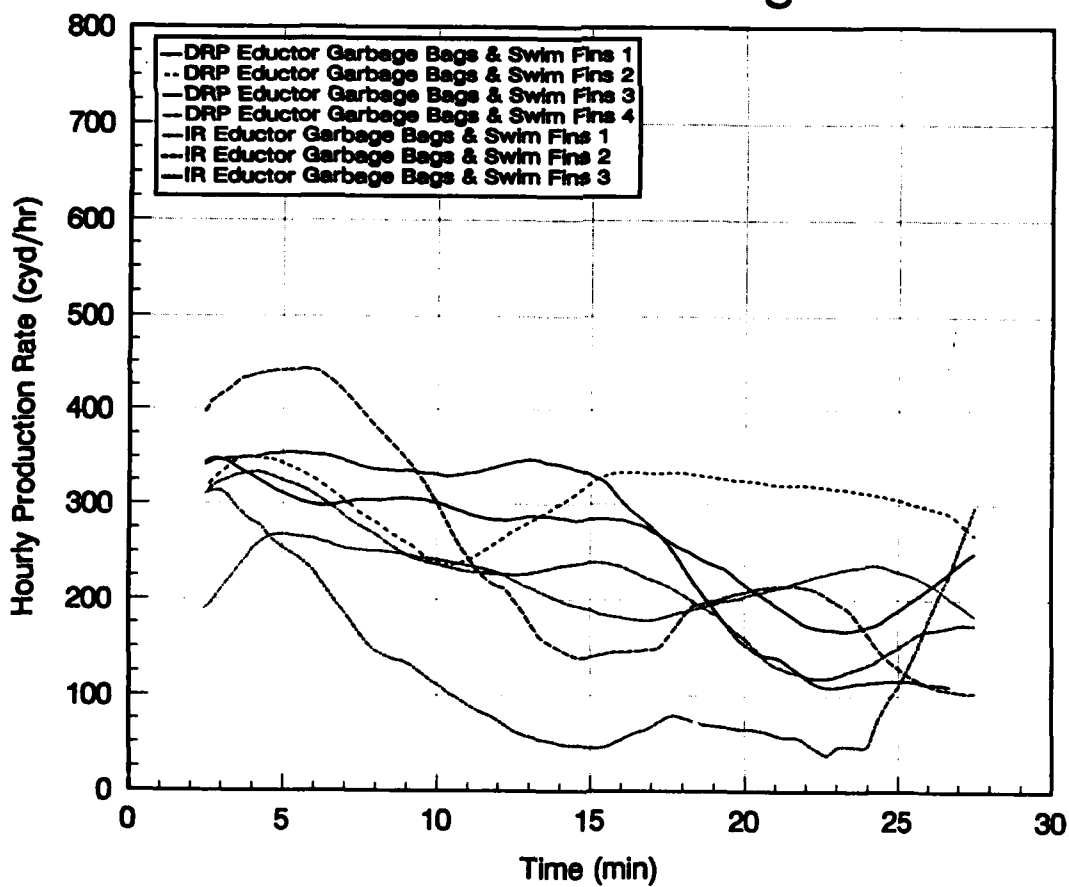

Hourly Production Rate Five Minute Averages

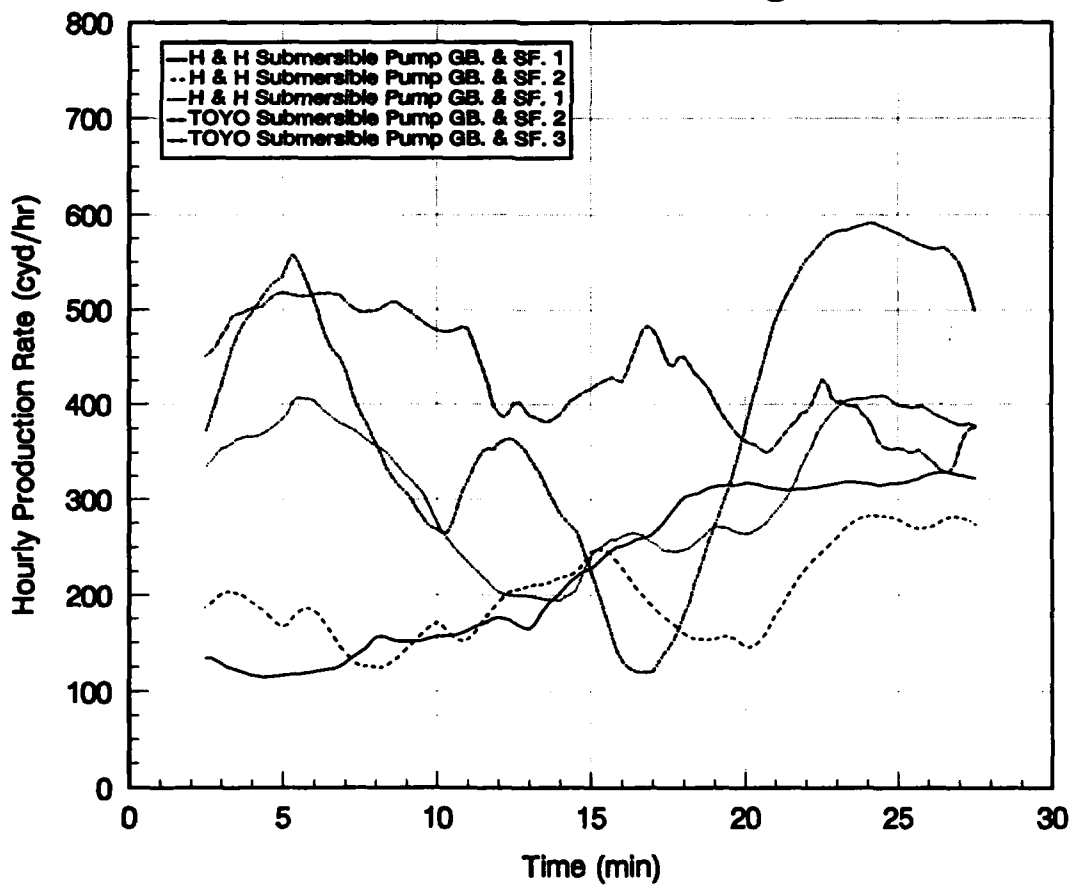

Hourly Production Rate Five Minute Averages

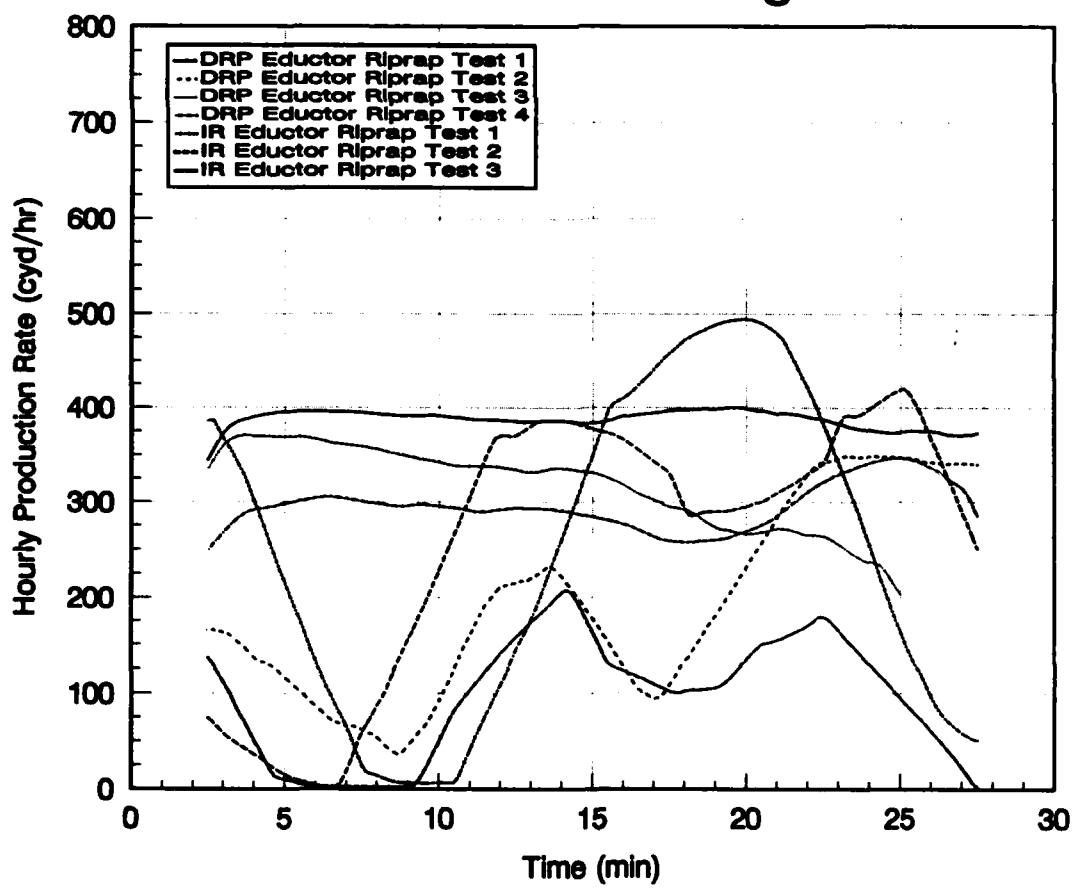

Hourly Production Rate Five Minute Averages

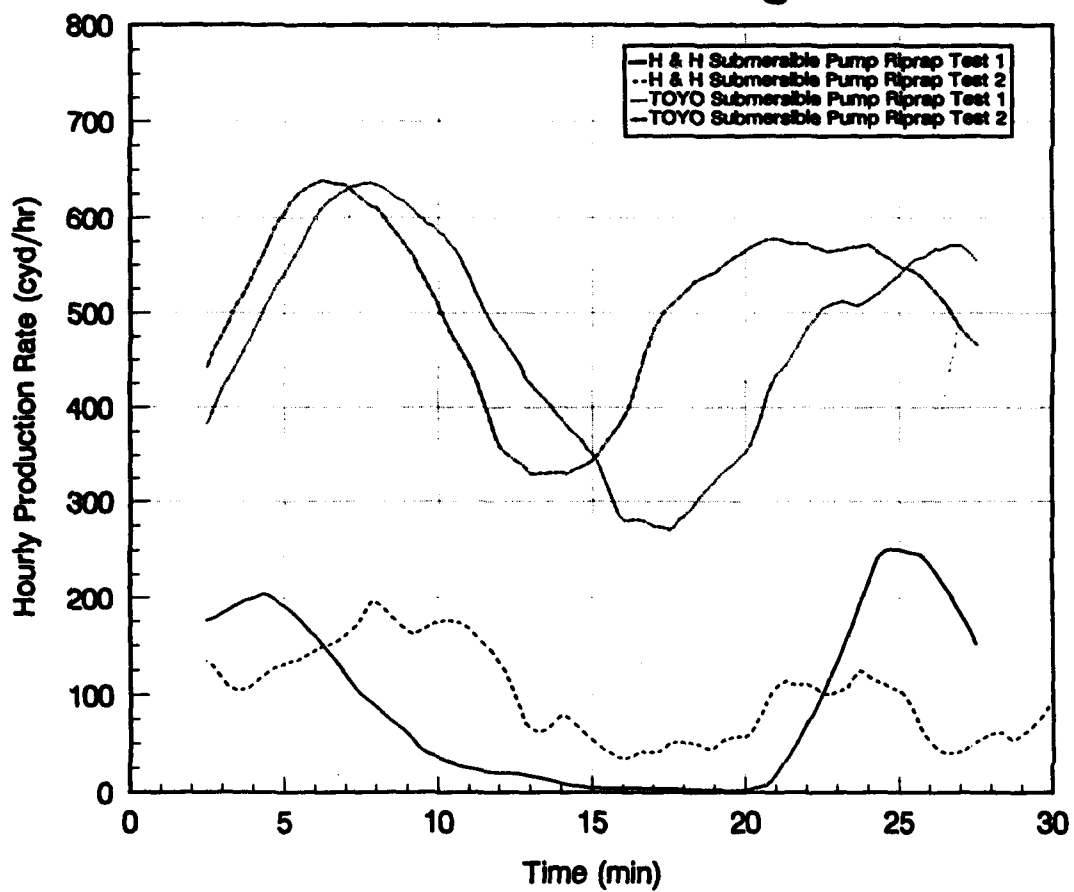

Hourly Production Rate Five Minute Averages

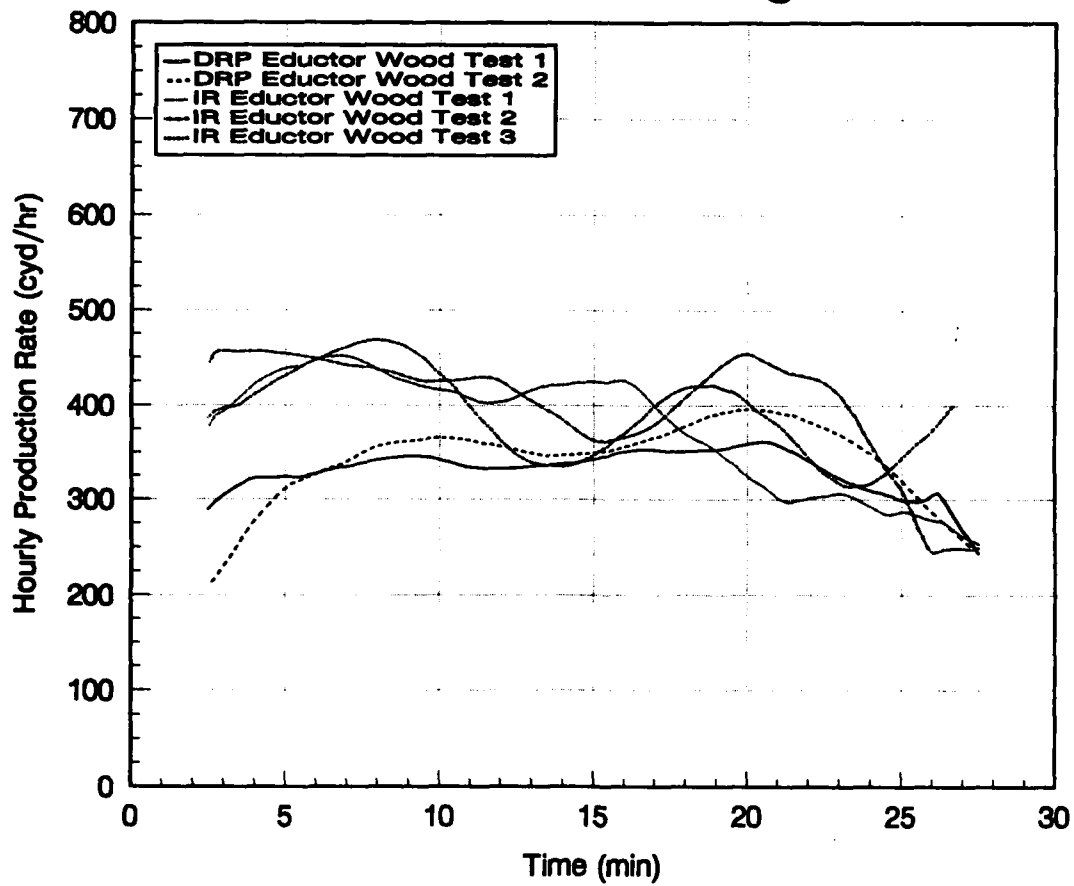

Hourly Production Rate Five Minute Averages

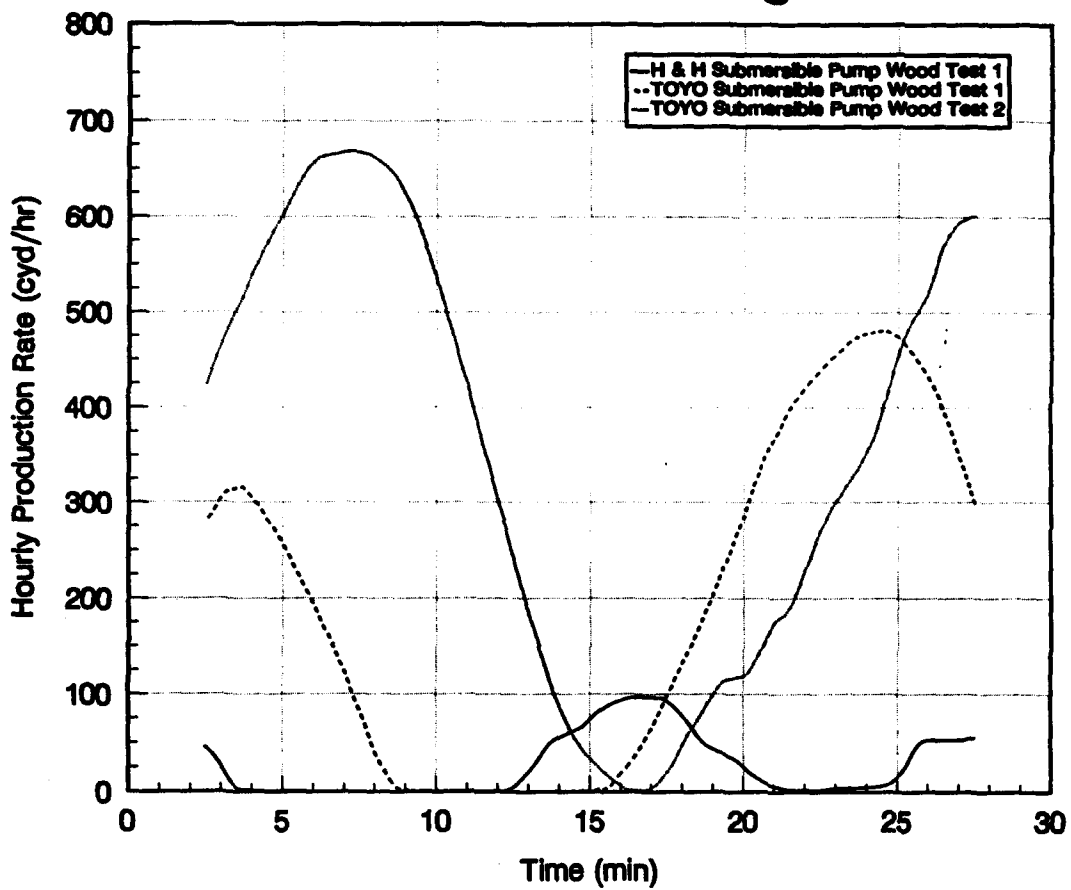

**Slurry Specific Gravity
H & H Submersible Pump
Clean Sand Test 1**

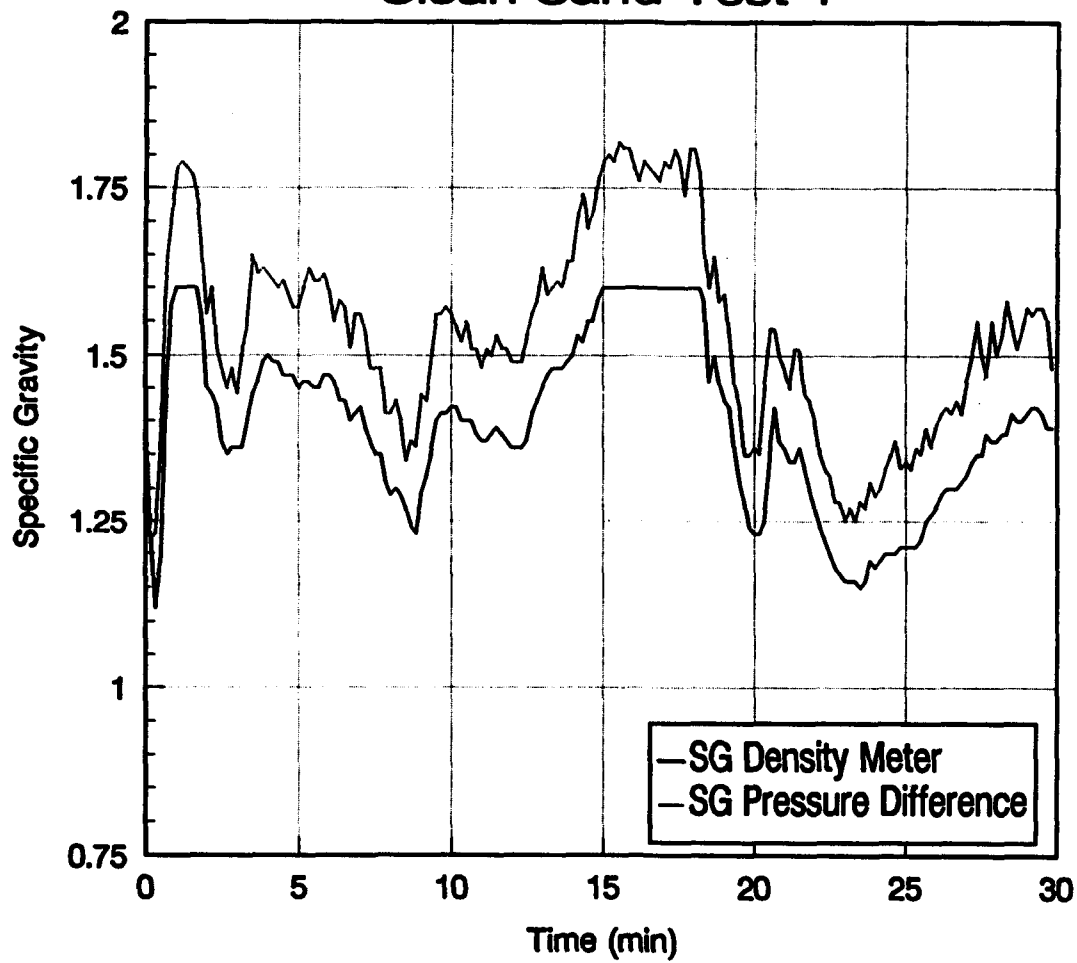

**Slurry Specific Gravity
H & H Submersible Pump
Clean Sand Test 2**

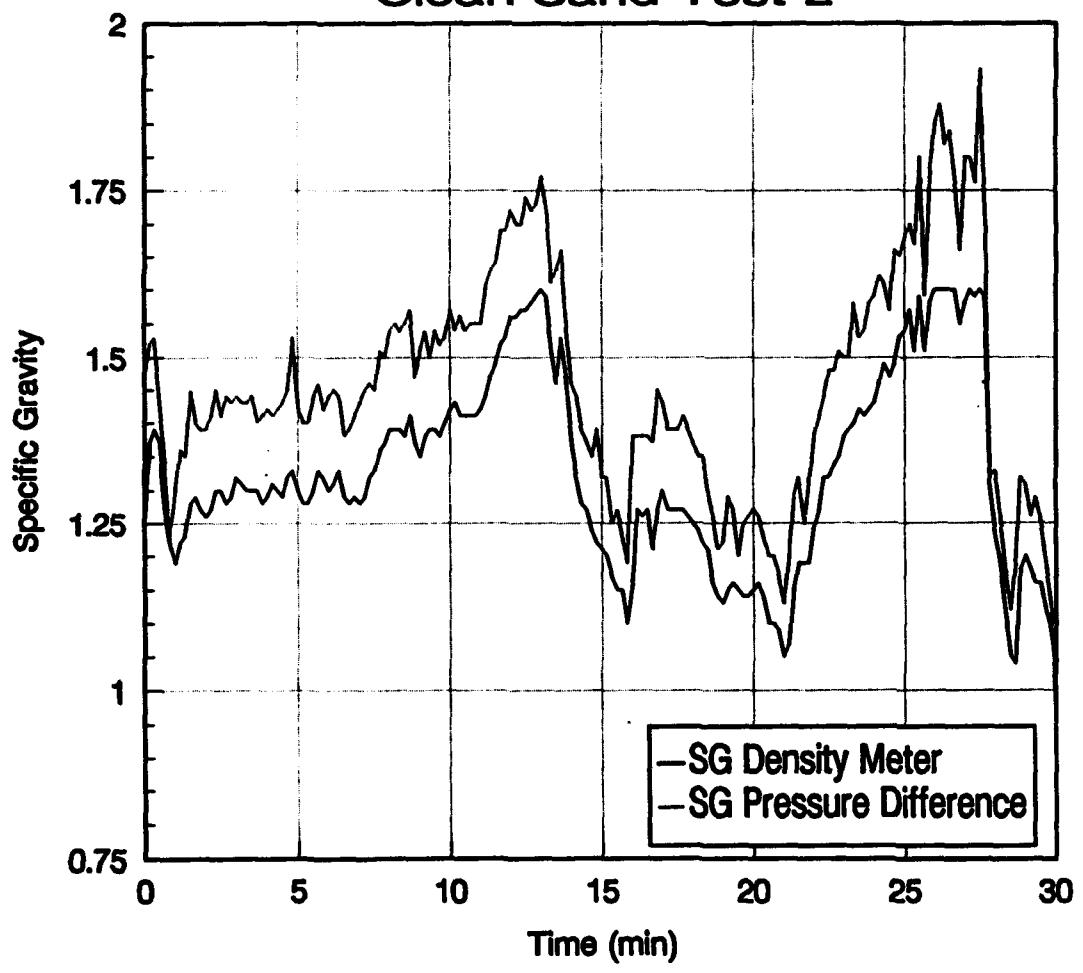

Slurry Specific Gravity
H & H Submersible Pump
Wood Test 1

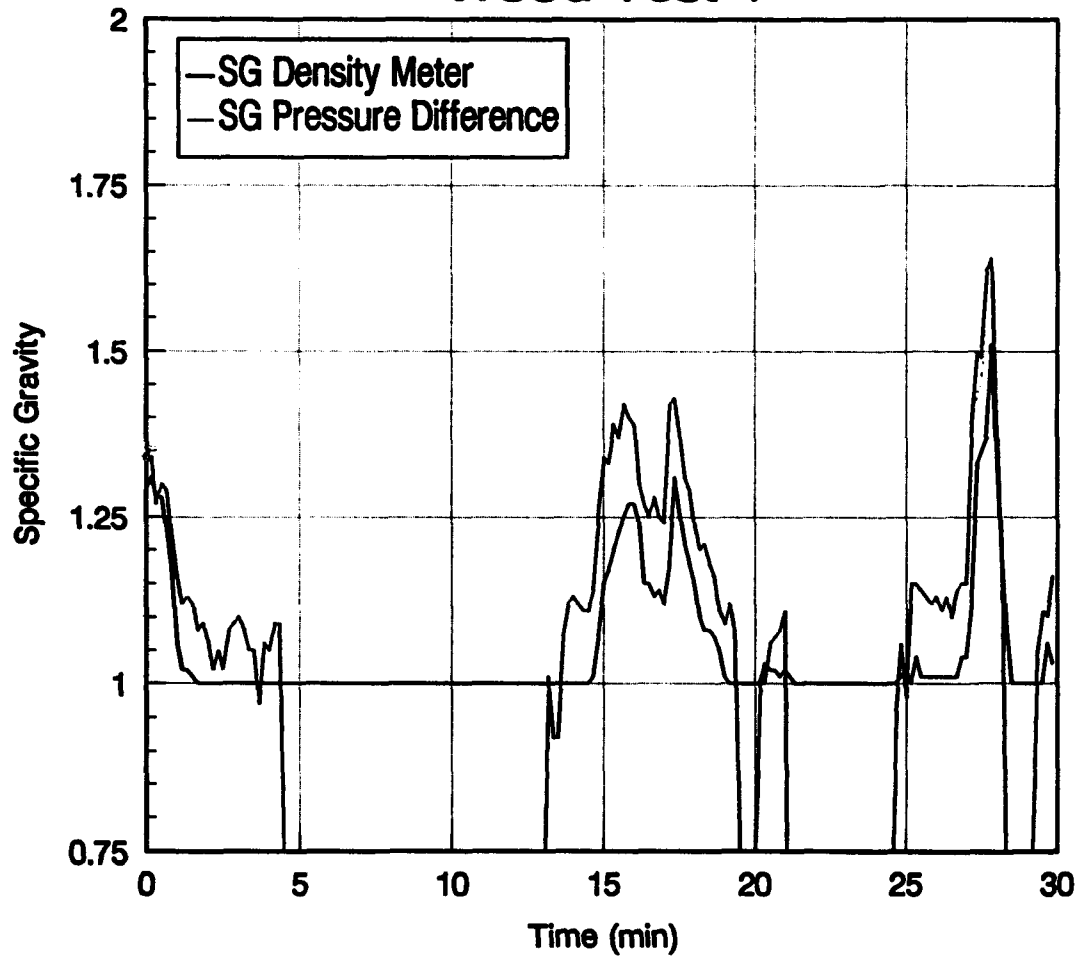

Slurry Specific Gravity H & H Submersible Pump Riprap Test 1

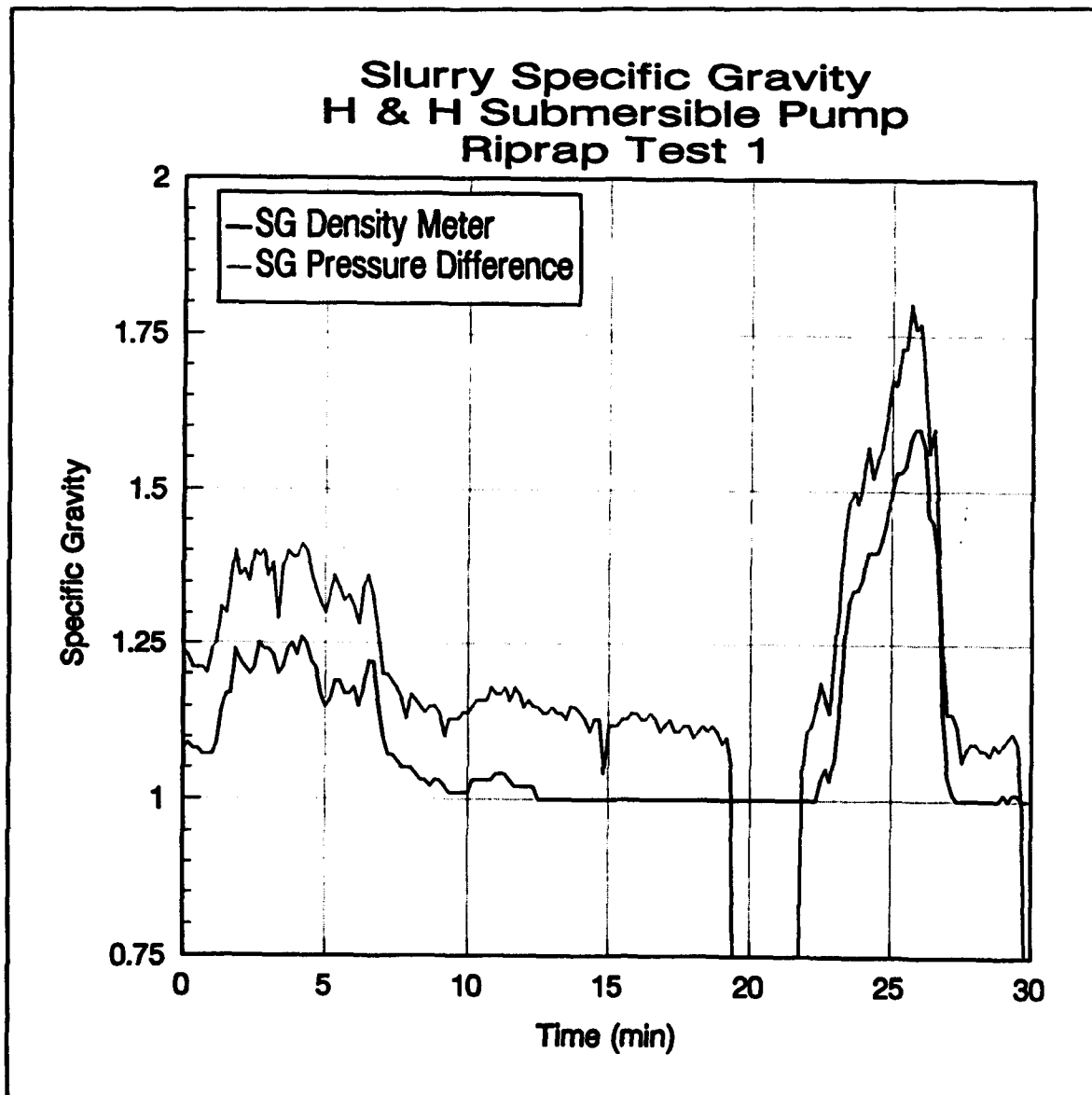

**Slurry Specific Gravity
H & H Submersible Pump
Riprap Test 2**

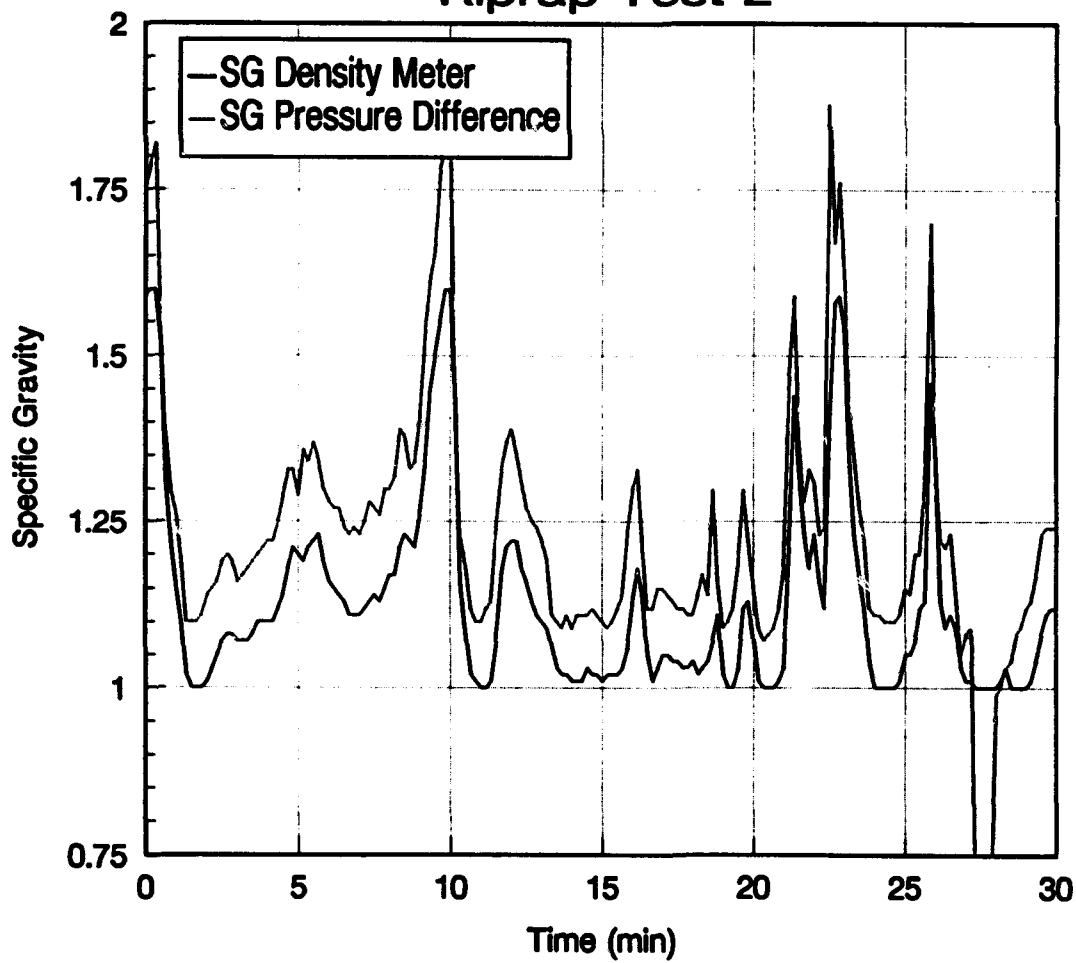

Slurry Specific Gravity
H & H Submersible Pump
Garbage Bags & Swim Fins Test 1

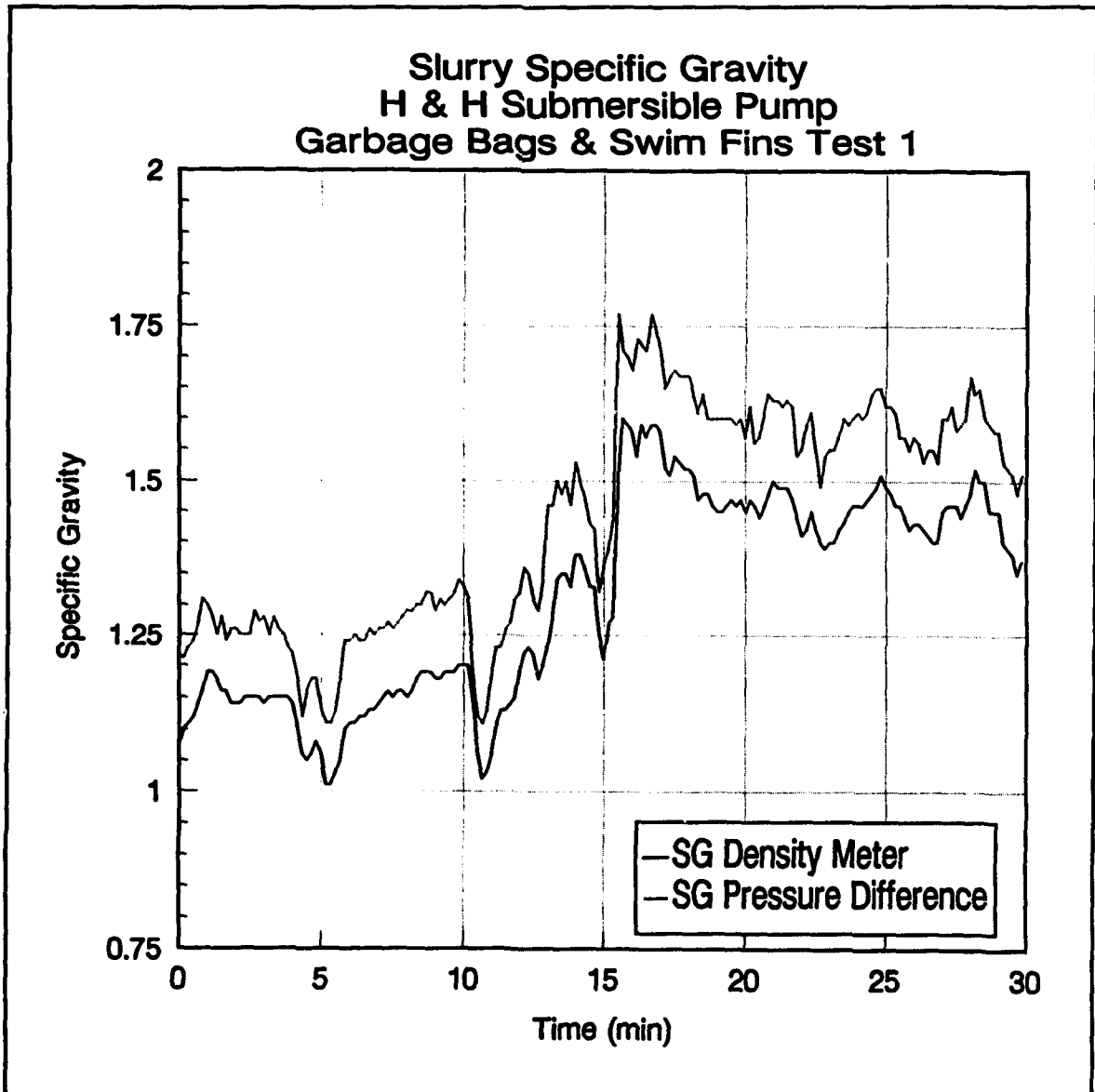

Slurry Specific Gravity
H & H Submersible Pump
Garbage Bags & Swim Fins Test 2

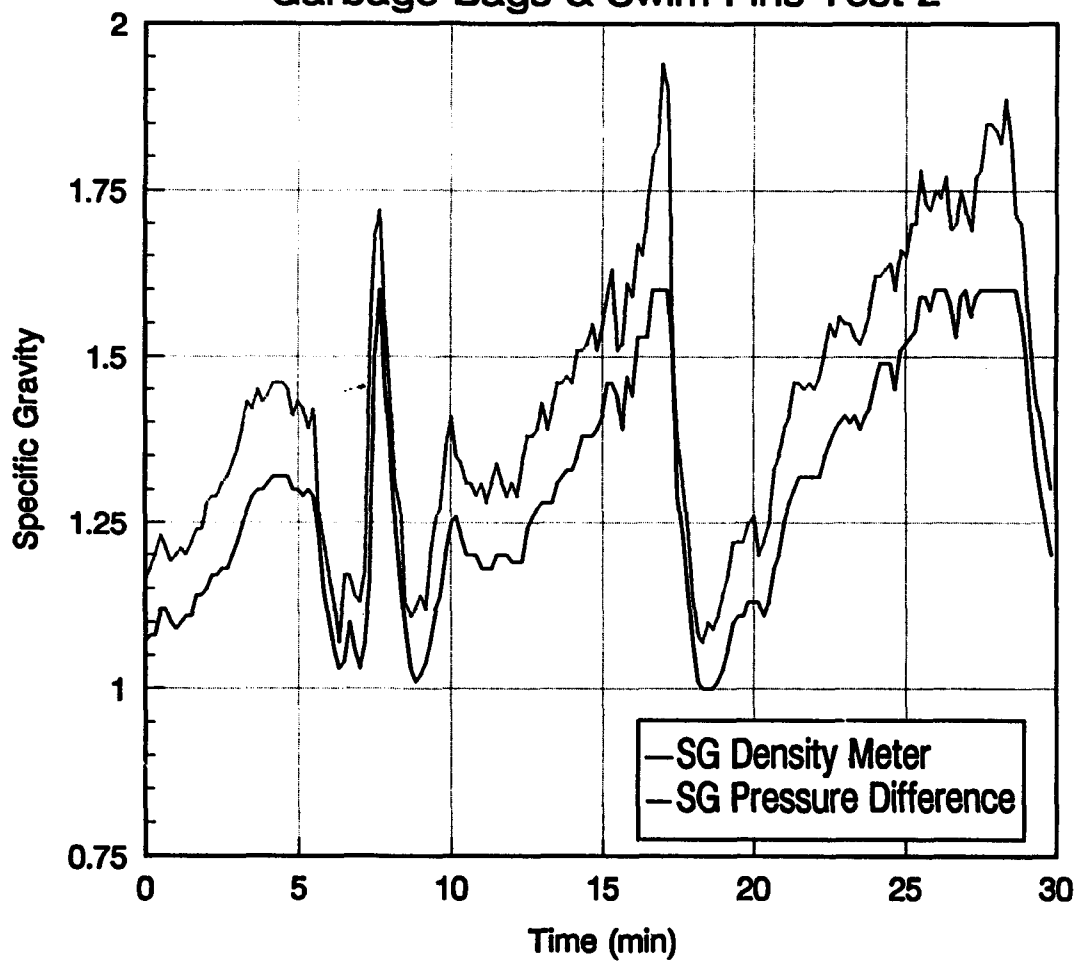

Slurry Specific Gravity
TOYO Submersible Pump
Clean Sand Test 1

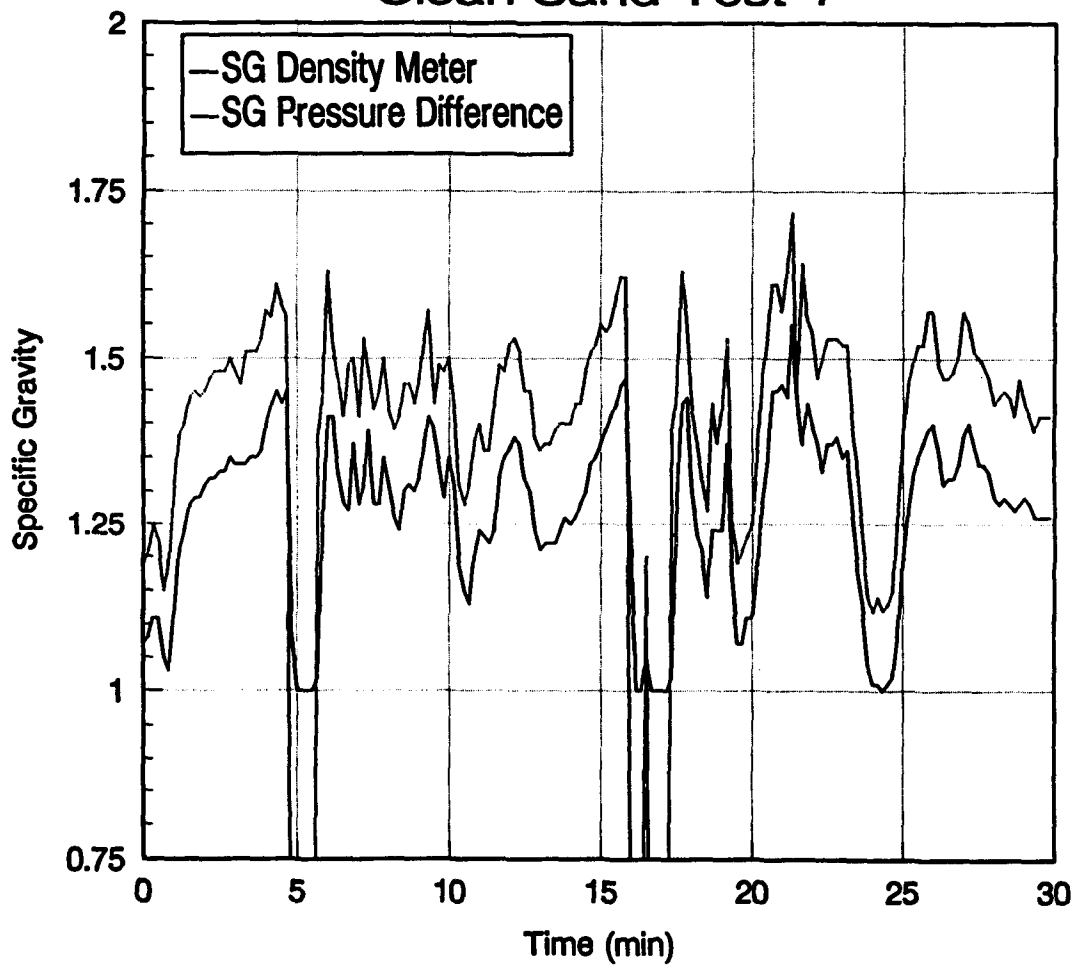

Slurry Specific Gravity
TOYO Submersible Pump
Clean Sand Test 1

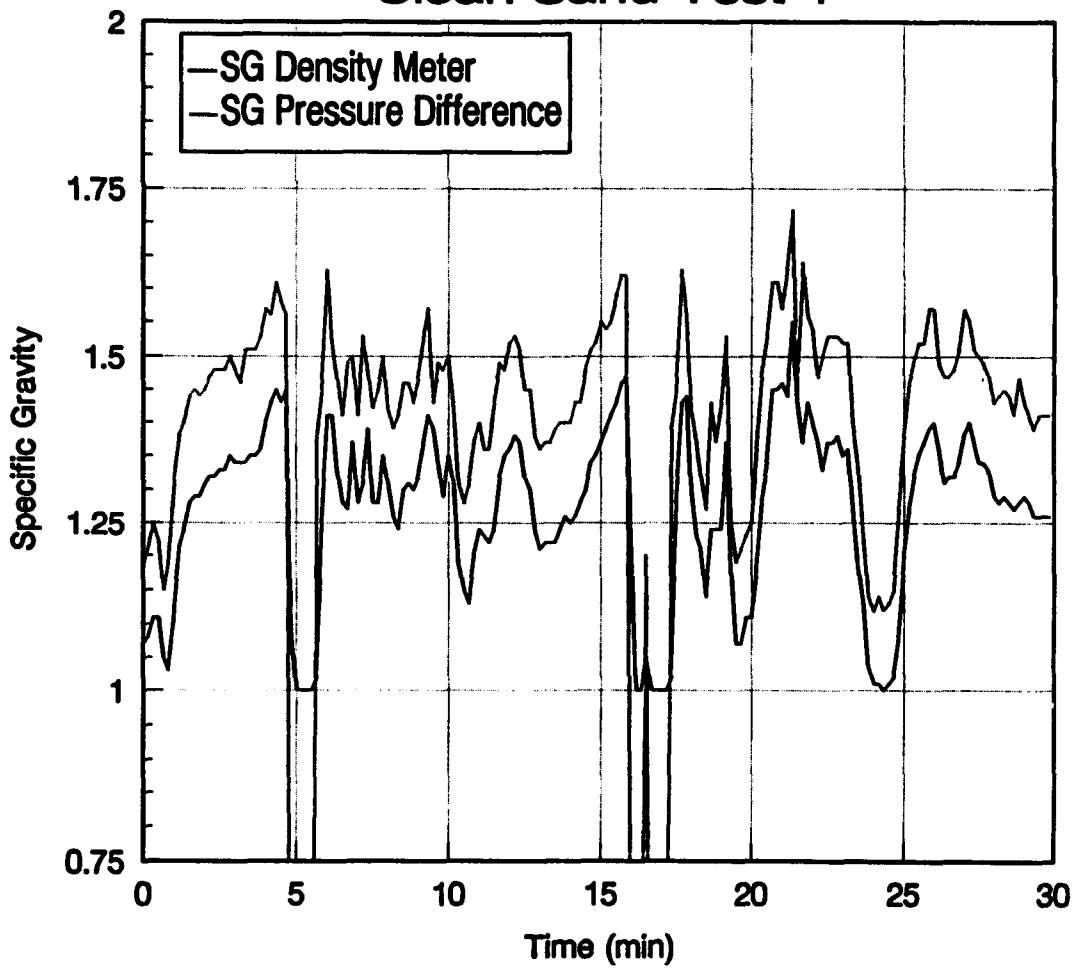

**Slurry Specific Gravity
TOYO Submersible Pump
Clean Sand Test 2**

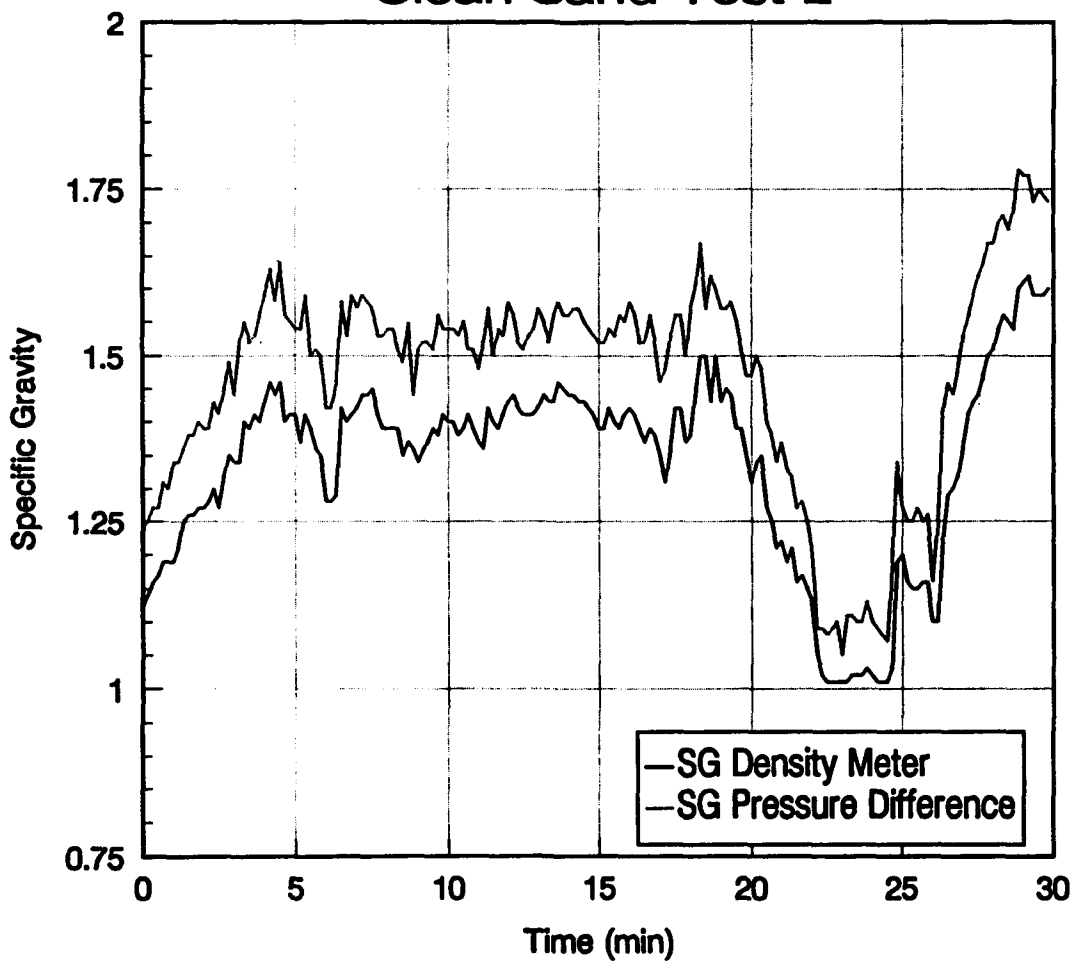

**Slurry Specific Gravity
TOYO Submersible Pump
Garbage Bags & Swim Fins Test 1**

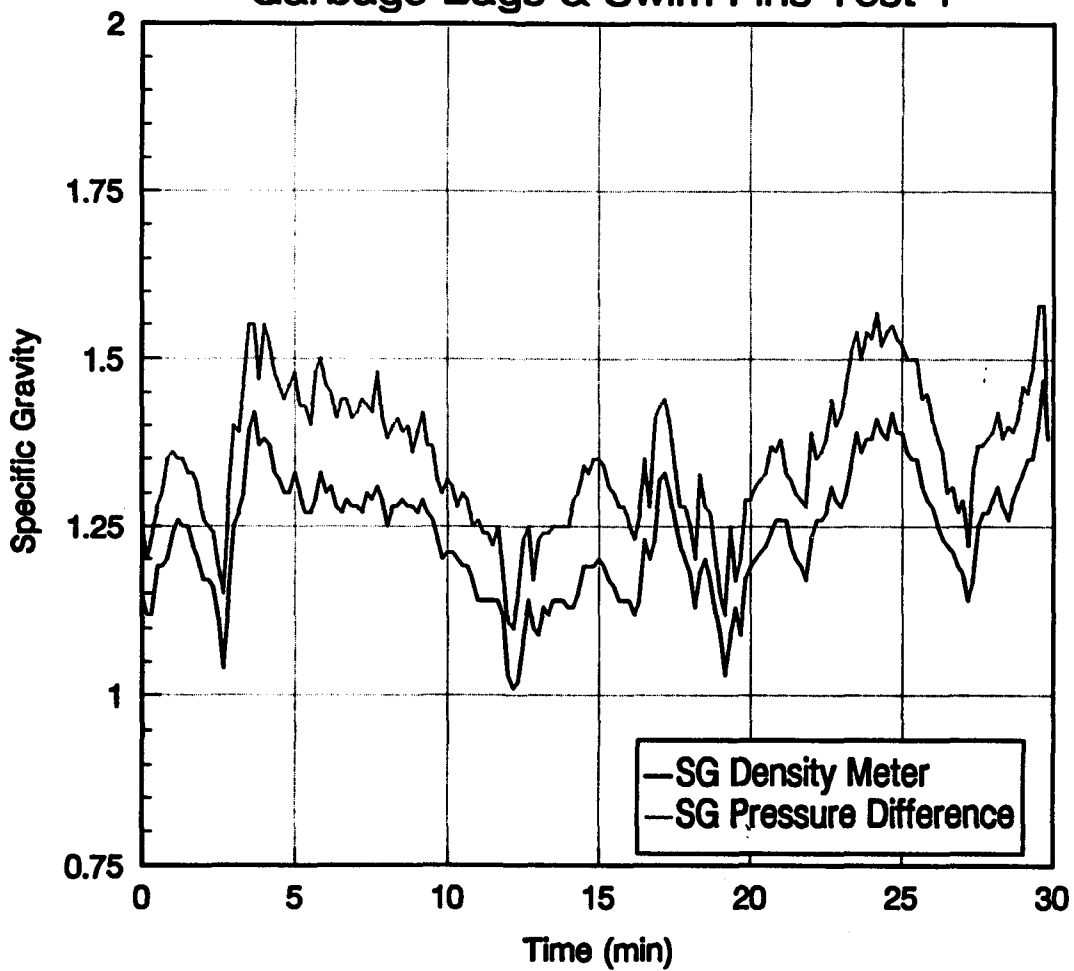

Slurry Specific Gravity
TOYO Submersible Pump
Garbage Bags & Swim Fins Test 2

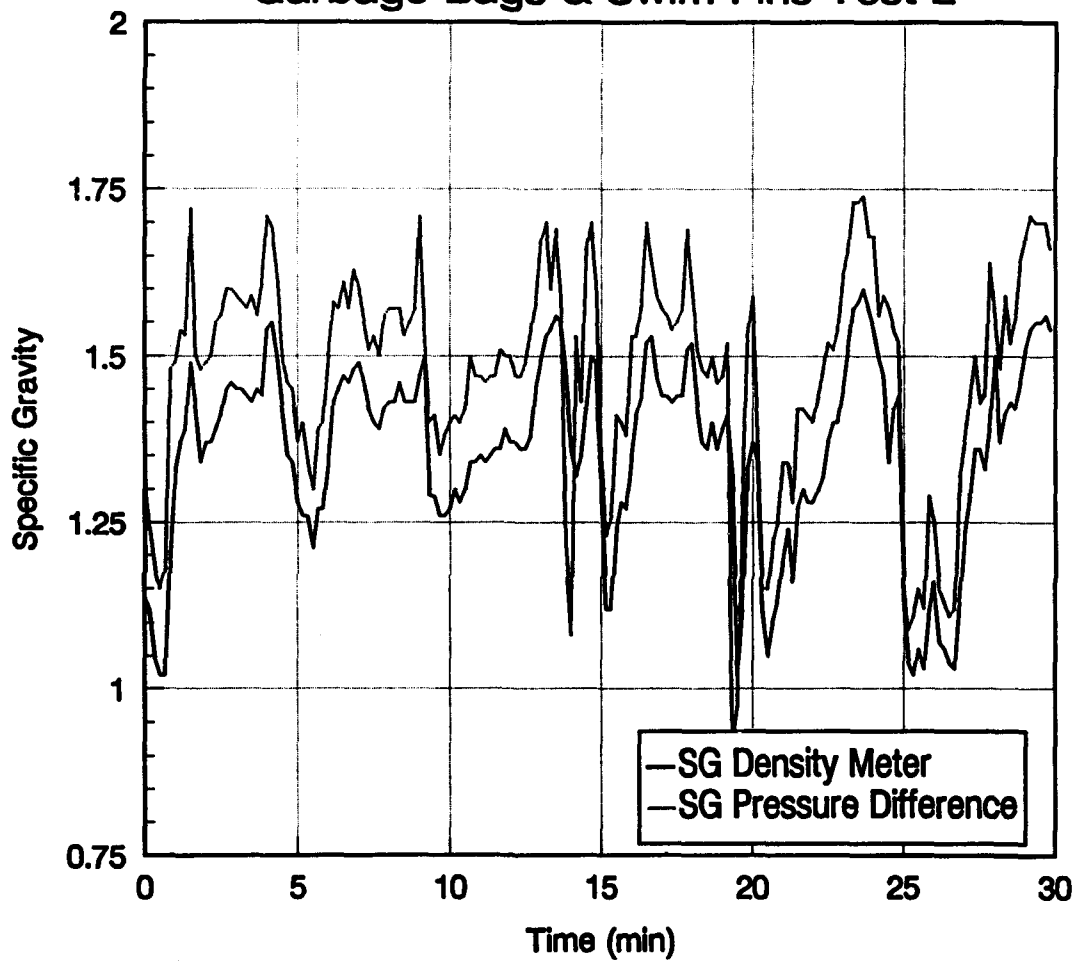

**Slurry Specific Gravity
TOYO Submersible Pump
Garbage Bags & Swim Fins Test 3**

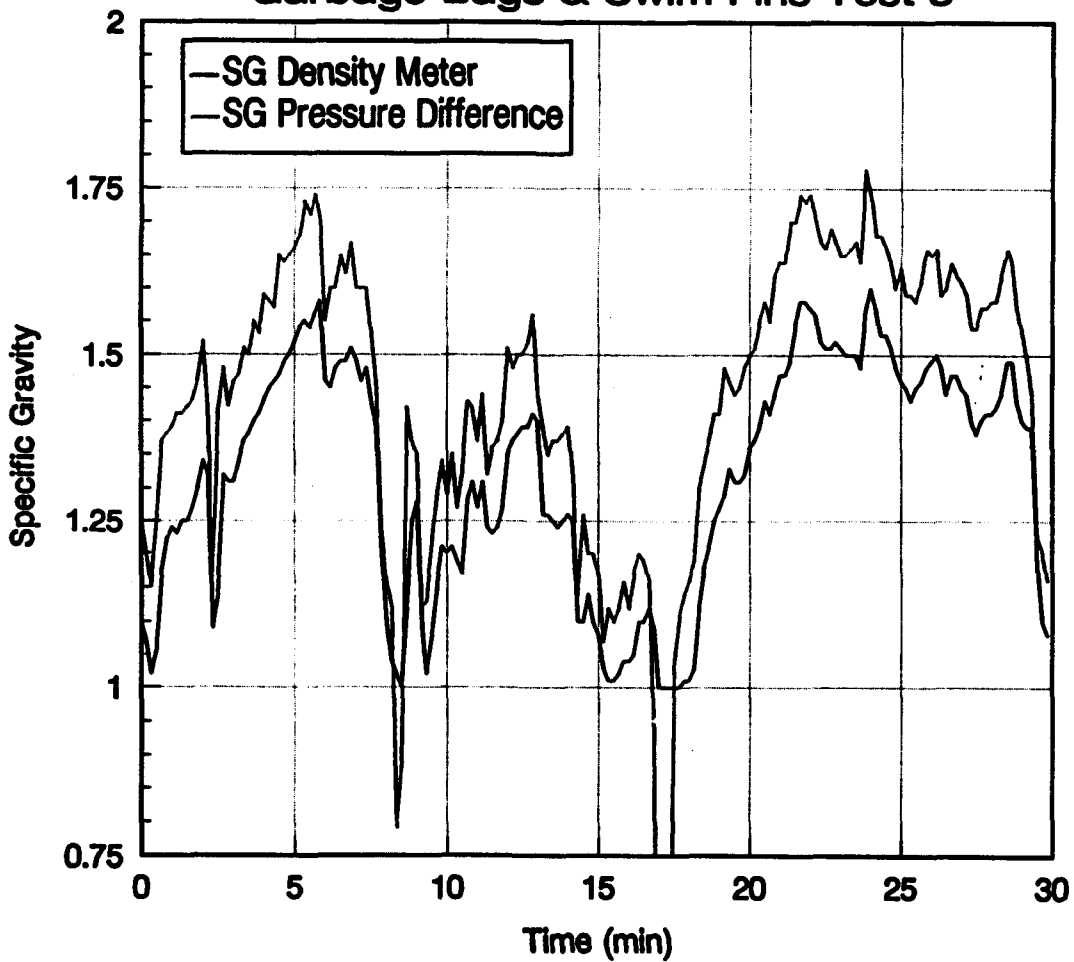

Slurry Specific Gravity
TOYO Submersible Pump
Wood Test 1

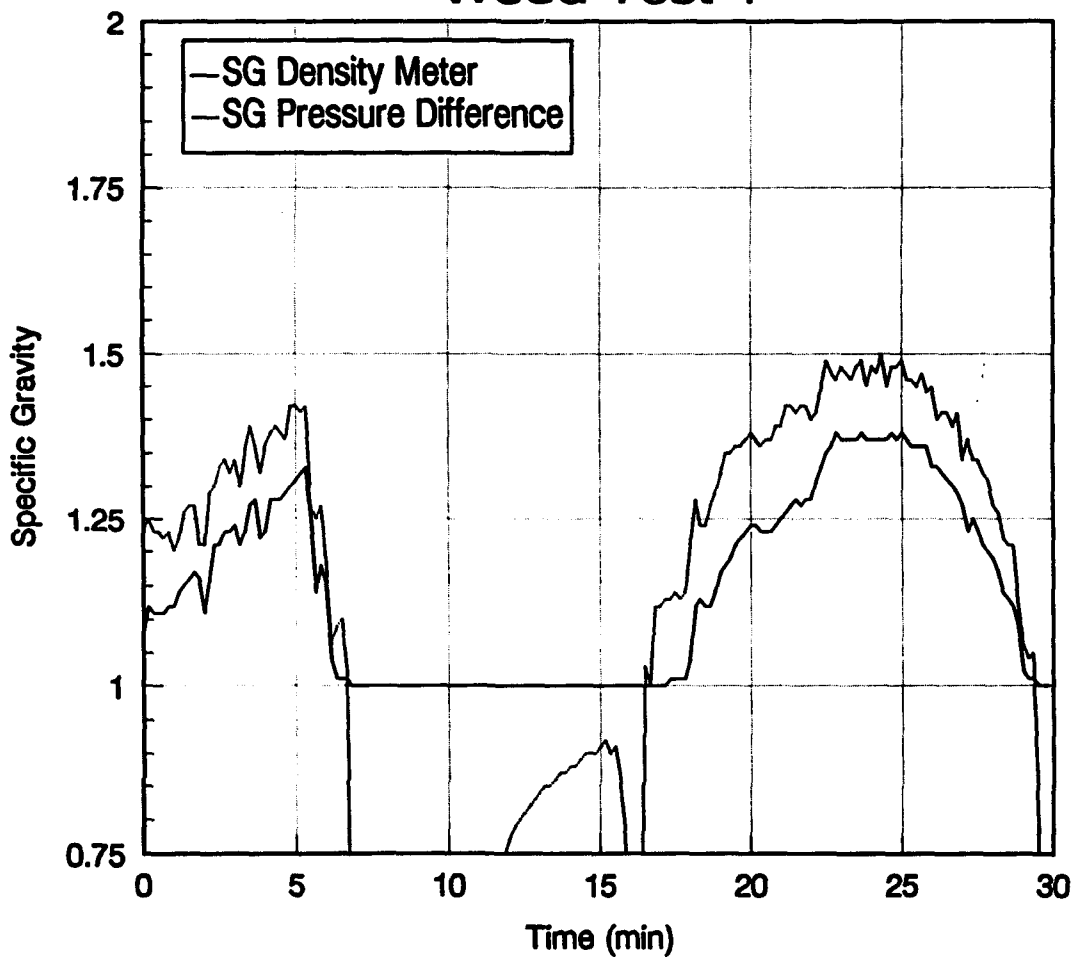

Slurry Specific Gravity
TOYO Submersible Pump
Wood Test 2

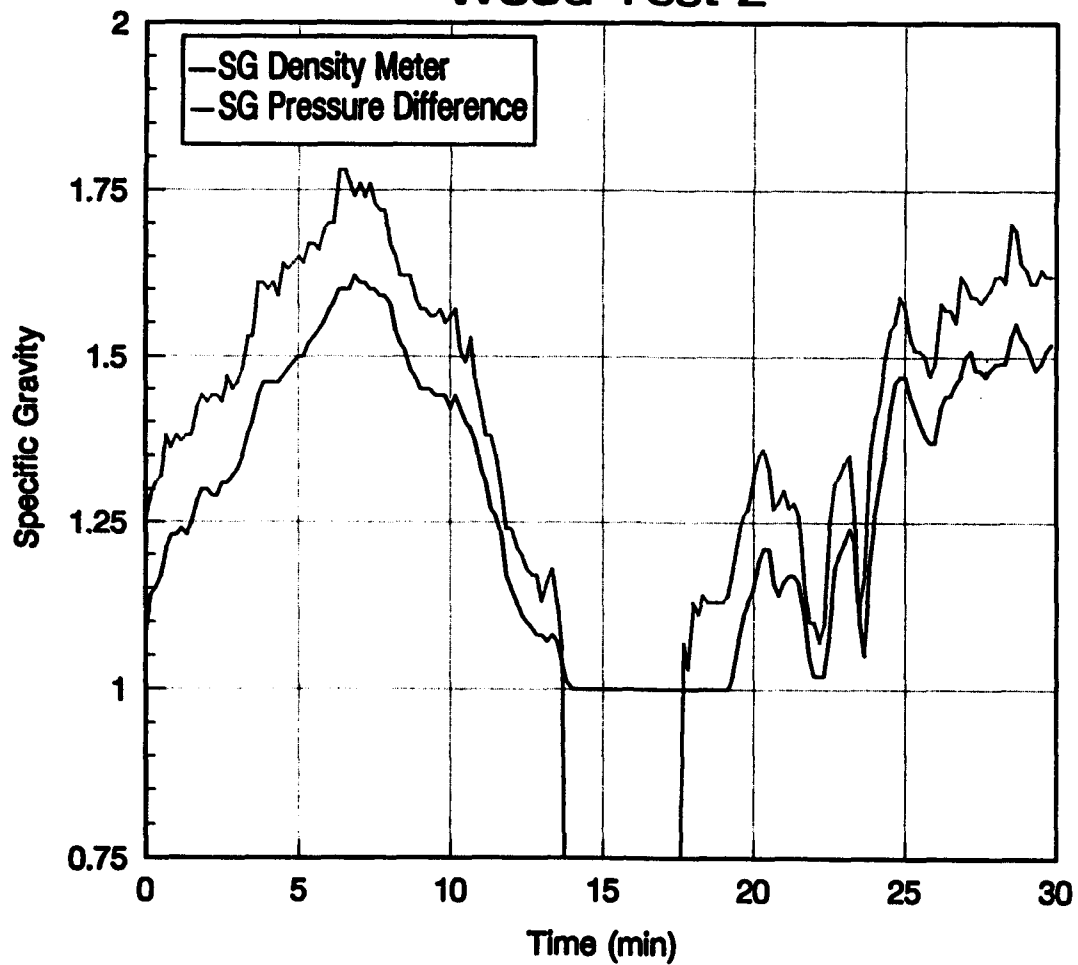

**Slurry Specific Gravity
TOYO Submersible Pump
Riprap Test 1**

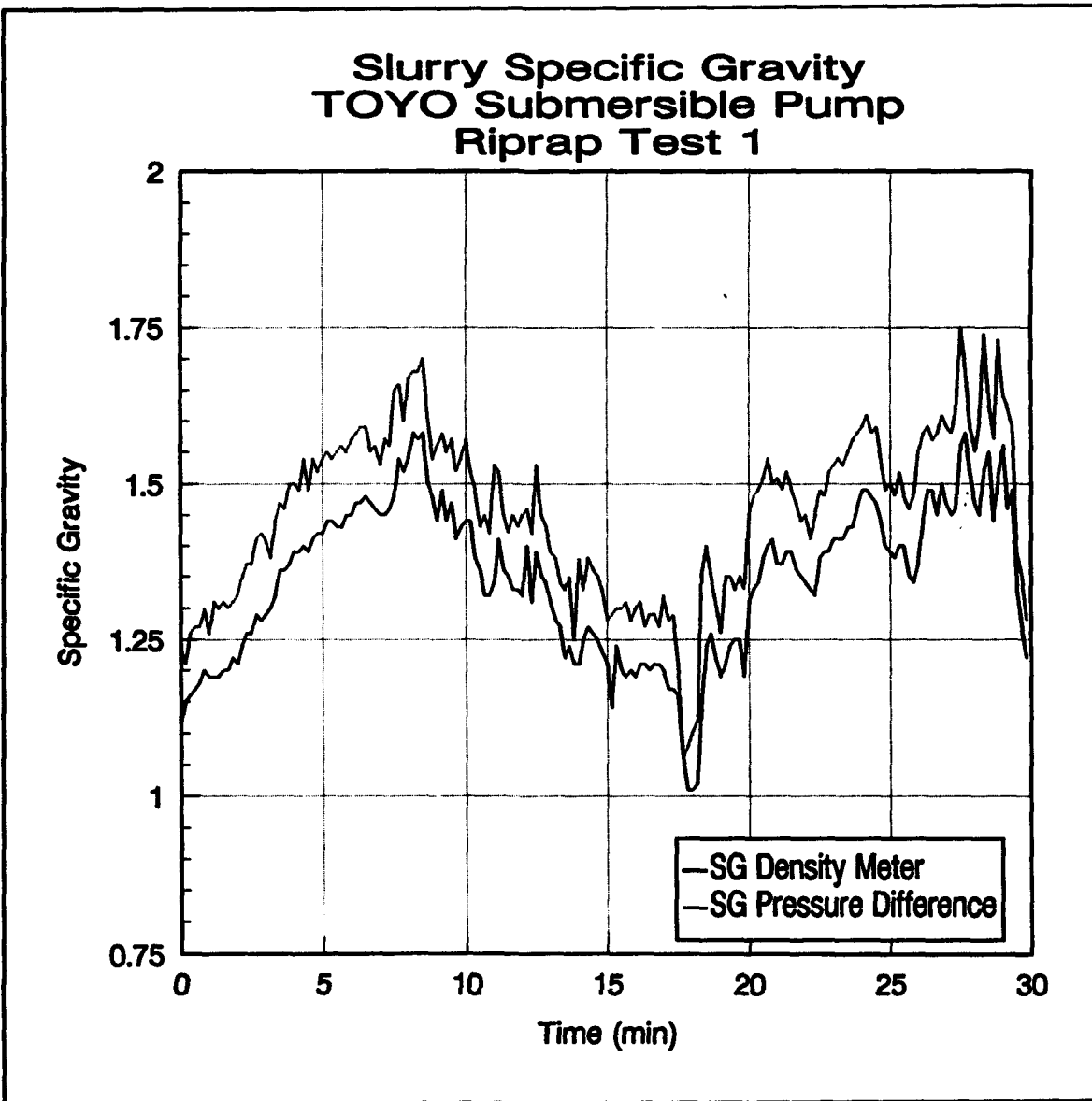

**Slurry Specific Gravity
TOYO Submersible Pump
Riprap Test 2**

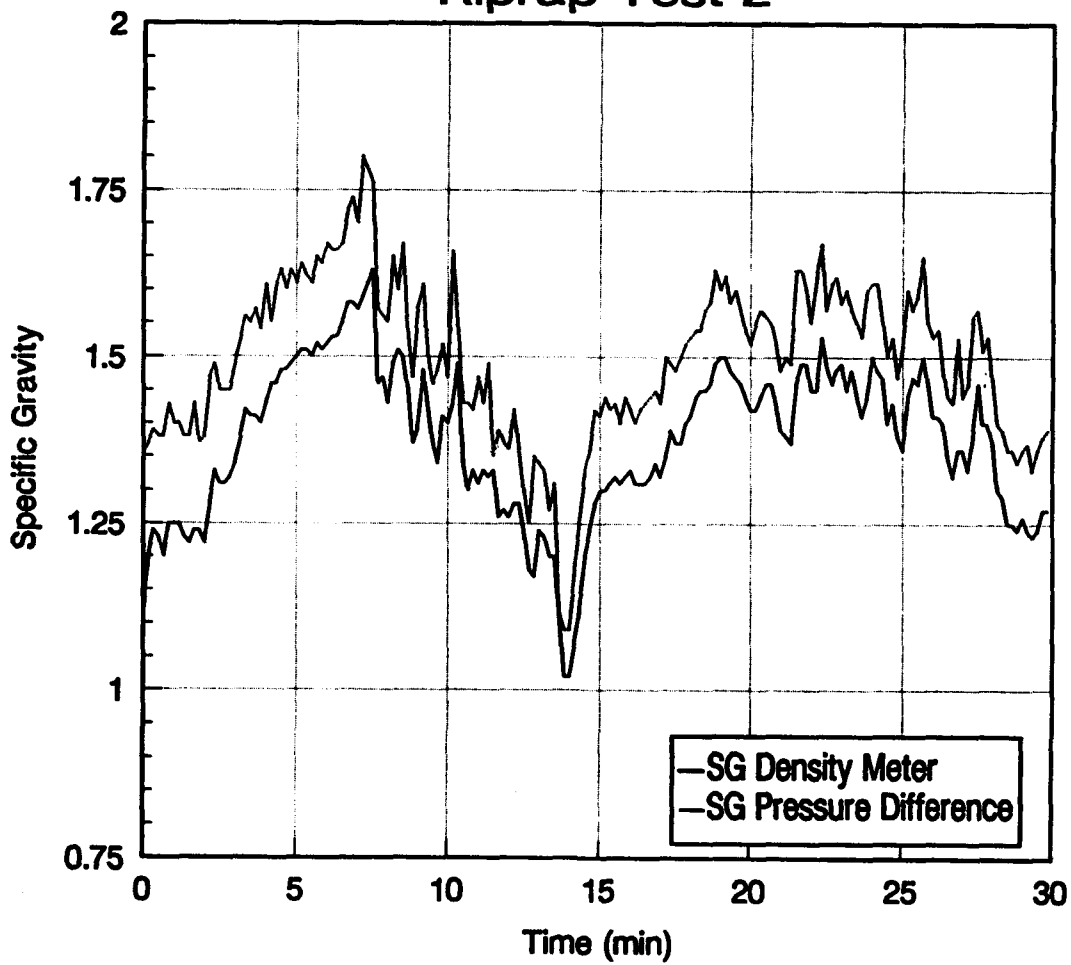

REPORT DOCUMENTATION PAGE

Form Approved
OMB No. 0704-0188

Public reporting burden for this collection of information is estimated to average 1 hour per response, including the time for reviewing instructions, searching existing data sources, gathering and maintaining the data needed, and completing and reviewing the collection of information. Send comments regarding this burden estimate or any other aspect of this collection of information, including suggestions for reducing this burden, to Washington Headquarters Services, Directorate for Information Operations and Reports, 1215 Jefferson Davis Highway, Suite 1204, Arlington, VA 22202-4302, and to the Office of Management and Budget, Paperwork Reduction Project (0704-0188), Washington, DC 20503.

1. AGENCY USE ONLY (Leave blank)		2. REPORT DATE September 1994	3. REPORT TYPE AND DATES COVERED Final report	
4. TITLE AND SUBTITLE Controlled Tests of Eductors and Submersible Pumps			5. FUNDING NUMBERS	
6. AUTHOR(S) James E. Clausner, Peter J. Neilans, Timothy L. Welp, Darryl D. Bishop				
7. PERFORMING ORGANIZATION NAME(S) AND ADDRESS(ES) U.S. Army Engineer Waterways Experiment Station 3909 Halls Ferry Road, Vicksburg, MS 39180-6199			8. PERFORMING ORGANIZATION REPORT NUMBER Miscellaneous Paper DRP-94-2	
9. SPONSORING/MONITORING AGENCY NAME(S) AND ADDRESS(ES) Department of the Army U.S. Army Corps of Engineers Washington, DC 20314-1000			10. SPONSORING/MONITORING AGENCY REPORT NUMBER	
11. SUPPLEMENTARY NOTES Available from National Technical Information Service, 5285 Port Royal Road, Springfield, VA 22161.				
12a. DISTRIBUTION/AVAILABILITY STATEMENT Approved for public release; distribution is unlimited.			12b. DISTRIBUTION CODE	
13. ABSTRACT (Maximum 200 words) <p>An eductor developed under the Dredging Research Program, a commercial eductor with similar hydraulics, and two commercial submersible pumps were tested in clean sand and a variety of debris types to measure performance. A total of 61 tests were run. The two eductors had similar performance in clean sand. In rock and garbage bag/swim fin debris, the DRP eductor had higher production. In wood debris, the commercial eductor performed better. The Toyo Submersible Pump had the highest production of any unit tested, while the H&H pump had the lowest production. Both submersible pumps were susceptible to plugging of the discharge line. They required nearly constant operator adjustment to provide good production without plugging the discharge line. The eductors required much less operator adjustment and did not plug the discharge line. Pullout forces on the shrouded DRP eductor stayed low, less than 20,000 lb, when the unit was backflushed for a sufficient period to allow excess water to lubricate the entire outer surface of the eductor.</p>				
14. SUBJECT TERMS Debris Sand bypassing Eductors Submersible pumps Jet pumps			15. NUMBER OF PAGES 133	
			16. PRICE CODE	
17. SECURITY CLASSIFICATION OF REPORT UNCLASSIFIED	18. SECURITY CLASSIFICATION OF THIS PAGE UNCLASSIFIED	19. SECURITY CLASSIFICATION OF ABSTRACT	20. LIMITATION OF ABSTRACT	