

AD-A283 213



Naval Research Laboratory

Washington, DC 20375-5320



NRL/MR/6180--94-7490

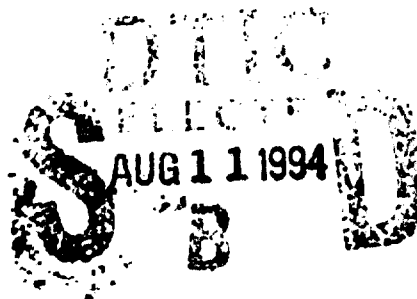

Use of Copper Powder Extinguishers on Lithium Fires

JOSEPH T. LEONARD

*Navy Technology Center for Safety and Survivability
Chemistry Division*

R. BURNS
J. BEITEL
R. OUELETTE

*Hughes Associates, Inc.
Columbia, MD*

R. DARWIN

*Naval Sea Systems Command
Washington, DC*

July 8, 1994

2606
94-25240

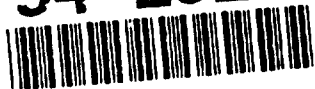

DISCLAIMER NOTICE

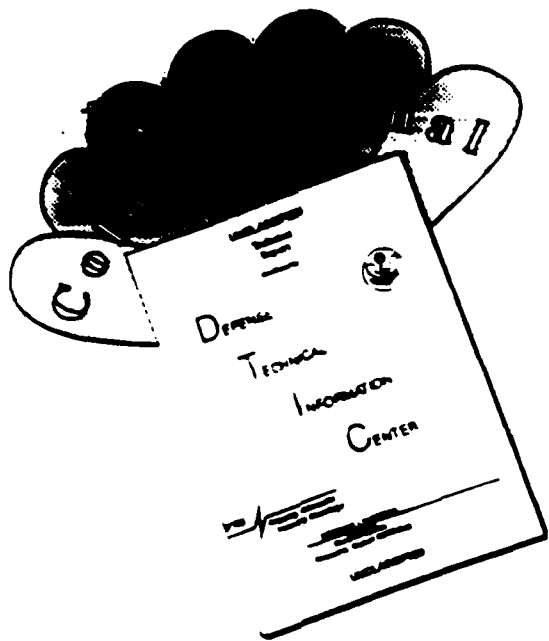

THIS DOCUMENT IS BEST QUALITY AVAILABLE. THE COPY FURNISHED TO DTIC CONTAINED A SIGNIFICANT NUMBER OF COLOR PAGES WHICH DO NOT REPRODUCE LEGIBLY ON BLACK AND WHITE MICROFICHE.

REPORT DOCUMENTATION PAGE

Form Approved
OMB No. 0704-0188

Public reporting burden for this collection of information is estimated to average 1 hour per response, including the time for reviewing instructions, searching existing data sources, gathering and maintaining the data needed, and completing and reviewing the collection of information. Send comments regarding this burden estimate or any other aspect of this collection of information, including suggestions for reducing this burden, to Washington Headquarters Services, Directorate for Information Operations and Reports, 1215 Jefferson Davis Highway, Suite 1204, Arlington, VA 22202-4302, and to the Office of Management and Budget, Paperwork Reduction Project (0704-0188), Washington, DC 20503.

1. AGENCY USE ONLY (Leave Blank)	2. REPORT DATE July 8, 1994	3. REPORT TYPE AND DATES COVERED	
4. TITLE AND SUBTITLE Use of Copper Powder Extinguishers on Lithium Fires		5. FUNDING NUMBERS 61-M259-X3	
6. AUTHOR(S) J. Leonard, R. Burns*, J. Beitel*, Ouelette* and R. Darwin**		8. PERFORMING ORGANIZATION REPORT NUMBER NRL/MR/6180-94-7490	
7. PERFORMING ORGANIZATION NAME(S) AND ADDRESS(ES) Naval Research Laboratory Washington, DC 20375-5320		10. SPONSORING/MONITORING AGENCY REPORT NUMBER	
9. SPONSORING/MONITORING AGENCY NAME(S) AND ADDRESS(ES) Undersea Warfare Systems		11. SUPPLEMENTARY NOTES * Hughes Associates, Inc., Columbia, MD 21045 **Naval Sea Systems Command, Washington, DC 20362-5101	
12a. DISTRIBUTION/AVAILABILITY STATEMENT Approved for public release; distribution unlimited.		12b. DISTRIBUTION CODE	
13. ABSTRACT (Maximum 200 words) The suitability of using copper powder extinguishers for controlling lithium fires resulting from a damaged Mark 50 Torpedo boiler assembly was evaluated. The results indicated that under ideal conditions, i.e., unobstructed access to the fire, copper powder will extinguish burning lithium when applied at the recommended rate of 4.5 kg (10 lb) of copper per 0.45 kg (1 lb) of lithium. However, the presence of obstructions or of high spots on the surface of the burning lithium increases the quantity of copper powder required for extinguishment.			
14. SUBJECT TERMS Lithium fires Copper powder extinguishers Fire extinguishment		15. NUMBER OF PAGES 27	
17. SECURITY CLASSIFICATION OF REPORT UNCLASSIFIED		16. PRICE CODE	
18. SECURITY CLASSIFICATION OF THIS PAGE UNCLASSIFIED	19. SECURITY CLASSIFICATION OF ABSTRACT UNCLASSIFIED	20. LIMITATION OF ABSTRACT UL	

Table of Contents

Background	1
Objectives	1
Approach	2
Experimental	8
Results and Discussions	13
Findings	22
Suitability for Shipboard Use	23
References	25

Accession For	
NTIS GRA&I	<input checked="" type="checkbox"/>
DTIC TAB	<input type="checkbox"/>
Unannounced	<input type="checkbox"/>
Justification	
By _____	
Distribution/Avail _____	
Availability Codes	
Dist	Avail and/or Special
A-1	

USE OF COPPER POWDER EXTINGUISHERS ON LITHIUM FIRES

BACKGROUND

The MK 50 Torpedo is a lightweight antisubmarine warfare (ASW) weapon that can be operationally delivered from fixed-wing aircraft, ASW helicopters, and surface combatants. The torpedo is propelled by a Stored Chemical Energy Propulsion System (SCEPS) which utilizes 7.25 kg (16 lb) of lithium metal fuel housed in a stainless steel boiler assembly. Prior to torpedo launch, the lithium metal is in a solid state. However, hazard assessment tests conducted on the MK 50 Torpedo have indicated that direct mechanical damage to the boiler assembly (such as that caused by a bullet or fragment) can possibly breach the structure and cause molten lithium to leak [1]. This situation would occur only if the boiler assembly is penetrated and the boiler start charge is activated, causing the lithium metal to become molten. When lithium is in its molten state, it will react with both the oxygen and nitrogen in the air causing a fire on the exposed surface of the lithium mass.

Methods to extinguish or mitigate the hazards of lithium fires have been extensively analyzed and tested in various situations. These studies have shown that the risks associated with a lithium fire are acceptably small with one exception, viz, if the lithium fire occurs in a shipboard magazine compartment and the sprinkler system is activated. This is a remote possibility since the MK 50 Torpedoes will be stowed in protected chock locations when in surface combatant torpedo magazines.

OBJECTIVES

The objectives of these tests were as follows:

- to evaluate the effectiveness of commercially-available portable extinguishers using copper powder in extinguishing lithium fires;

- to evaluate the suitability of these extinguishers for shipboard use; and
- to determine what other factors need to be considered when deploying this extinguisher.

APPROACH

Commercially-available copper powder extinguishers were subjected to various inspections and tests to determine their suitability for use aboard ship. While this evaluation emphasized firefighting effectiveness, other features germane to the shipboard environment were examined such as materials of construction, corrosion resistance, maintainability, range (with and without wind), ability to recharge, suitability of mounting brackets, need for special training, size, weight, ease of handling, and other salient human factors.

Currently, there are two, commercially available, portable extinguishers for use on lithium fires: Ansul Model HF-CR-I-AG-CU-20-E and Amerex Model 571. Each extinguisher uses 13.6 kg (30 lb) of copper powder identified as Navy 1255.

Both extinguishers use pressurized argon gas as the propellant for the copper powder. The Amerex extinguisher is precharged with argon while the Ansul extinguisher has a separate argon cartridge that is discharged into the extinguisher just prior to use. Figure 1 is a photograph of the Ansul extinguisher, and Figure 2 is a photograph of the Amerex extinguisher.

The lithium for these tests was obtained from Cyprus Foote Mineral Corporation in 0.9 kg (2 lb) cylindrical ingots, approximately 12.7 cm (5 in.) in diameter and 12.7 cm (5 in.) high. A photo of these ingots in the stainless steel pan used to contain the molten lithium is shown in Figure 3.



Fig. 1 - Ansul extinguisher



Fig. 2 - Amerex extinguisher



Fig. 3 - Test pan with lithium ingot

Pertinent physical properties of the lithium ingots are as follows:

- **Purity:** 99.8% lithium,
- **Melting Point:** 180.5°C (357°F),
- **Flash Point:** 871°C (1600°F), and
- **Density:** 0.534 g/cm³.

It should be noted that although the flash point of lithium is given as 871°C (1600°F), lithium will react spontaneously with air at 180°C (356°F) if the surface of the metal is clean [2].

EXPERIMENTAL

A total of ten tests were conducted of which two were static discharge tests and eight were fire suppression tests of increasing complexity. Table 1 provides a summary of the test matrix.

For Tests 1 and 2, the extinguisher was placed on a load cell and its weight recorded as it was discharged.

Test No. 3 consisted of burning a 0.9 (2 lb) ingot of lithium in a 0.9 m (3 ft) diameter stainless steel pan (5.6 mm (7/32-in.) thick) using a diffusion flame acetylene torch as the ignitor. A single Ansul extinguisher was used to extinguish the fire.

Test No. 4 consisted of an attempt to ignite the lithium using a JP-4 fuel fire. A 0.9 kg (2 lb) lithium ingot was placed in the stainless steel pan, and approximately 4 gallons of JP-4 was placed into the pan and ignited. The JP-4 burned for about 8 minutes at which time, the lithium was melted but only partially ignited. The acetylene torch was used to complete the ignition of the molten lithium.

Table 1. Copper Extinguisher Test Matrix

Test No.	Test Date	Amount of Lithium (kg (lb))	Ignition	Extinguisher	Remarks
1	3/15/94	0 (0)	N/A	Ansul	Static discharge test
2	3/15/94	0 (0)	N/A	Amerex	Static discharge test
3	3/15/94	0.9 (2)	Torch	Ansul	
4	3/23/94	0.9 (2)	JP-4	Ansul	
5	3/23/94	1.8 (4)	Torch	Amerex	
6	3/24/94	3.6 (8)	Torch	Amerex	
7	3/24/94	3.6 (8)	Torch	Amerex	20 cm (8 in.) diameter obstruction over pan
8	3/25/94	1.8 (4) in pan 1.8 (4) in pipe	Torch	Ansul	20 cm (8 in.) diameter pipe with 1.9 cm (0.75 in.) hole over pan with lithium in pipe
9	4/8/94	3.6 (8)	Torch	Amerex/Ansul	Pan in compartment with simulated rack
10	4/8/94	1.8 (4)	Torch	Amerex/Ansul	Aluminum pan and steel pan

Test No. 5 consisted of burning two, 0.9 kg (2 lb) lithium ingots in the stainless steel pan and using the torch as the ignitor. An Amerex extinguisher was used to suppress the fire.

In Tests 6 and 7, four 0.9 kg (2 lb) lithium ingots were used. Test 6 was an unobstructed fire, and in Test 7, an 20.3 cm (8 in.) diameter pipe was placed four inches above the pan to provide an obstruction to firefighting. Extinguishment in both tests was with an Amerex extinguisher.

Test No. 8 consisted a three-dimensional fire. In this test, the 20.3 cm (8 in.) pipe was placed on the pan, an 1.9 cm (0.75 in.) hole was drilled into the pipe, and the hole was oriented such that it was at the 7 o'clock position. Two, 0.9 kg (2 lb) lithium ingots were placed in the pipe near the hole, and two, 0.9 kg (2 lb) lithium ingots were placed in the pan. The lithium ingot in the pan was ignited using the torch, which was then used to ignite the lithium in the pipe.

Test No. 9 consisted of burning four, 0.9 kg (2 lb) lithium ingots of lithium in the stainless steel pan inside an 2.4 x 2.4 x 2.4 m (8 x 8 x 8 ft) compartment. The pan was located as shown in Figures 4 and 5. Over the top of the pan, a simulated torpedo rack was installed. The lithium was ignited via the torch.

Test No. 10 consisted of burning two, 0.9 kg (2 lb) lithium ingots in an aluminum pan that was placed inside a steel pan. The aluminum pan was 36 x 46 x 10 cm (14 x 18 x 4 in.) and constructed of 6.4 mm (0.25 in.) thick aluminum. The carbon steel pan which contained the aluminum pan was 58 x 58 x 10 cm (23 x 23 x 4 in.) and constructed of 4.8 mm (3/16-in.) thick carbon steel. The lithium ingots were placed into the aluminum pan and ignited. The temperature on the underside of the aluminum pan was monitored throughout the test, and after melt through, the underside steel pan temperatures were monitored.

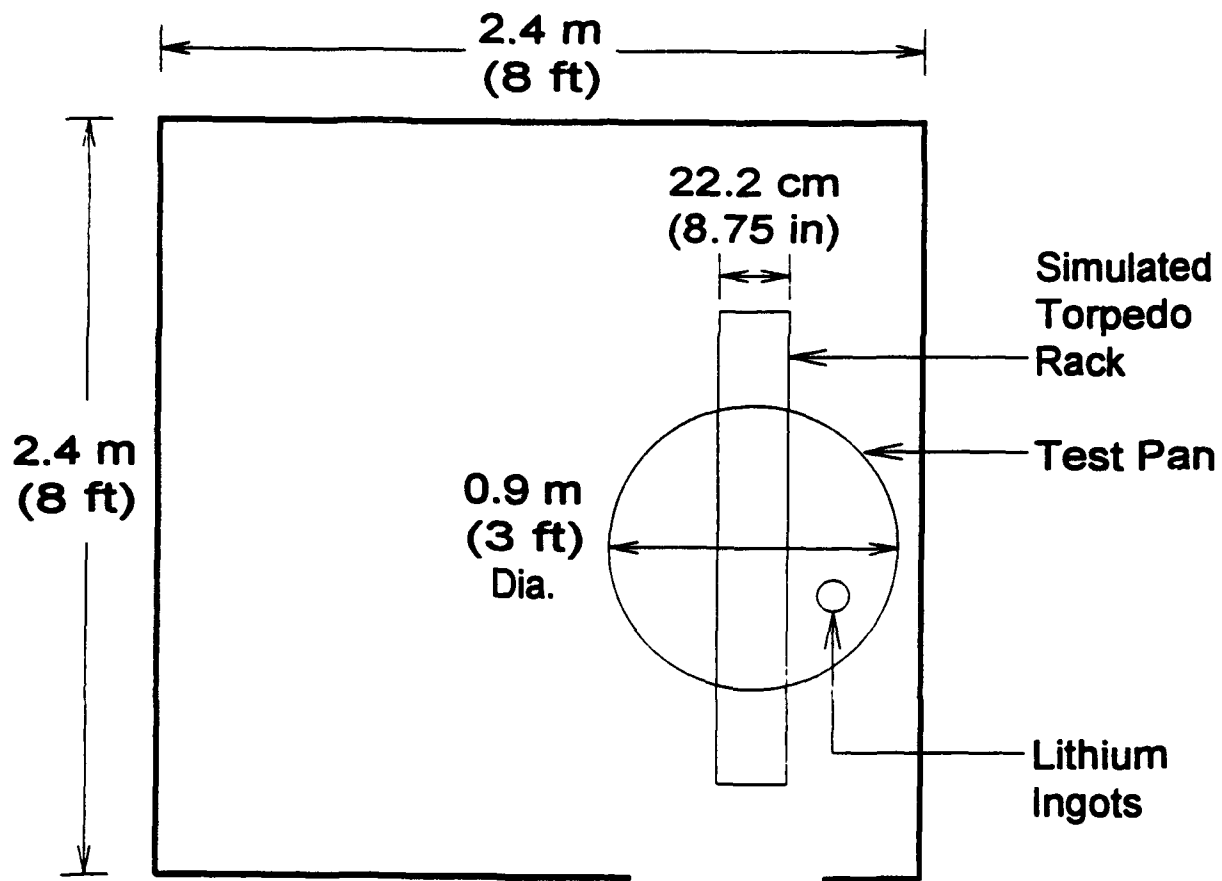

Fig. 4 - Plan view of test compartment showing locations of pan and simulated torpedo

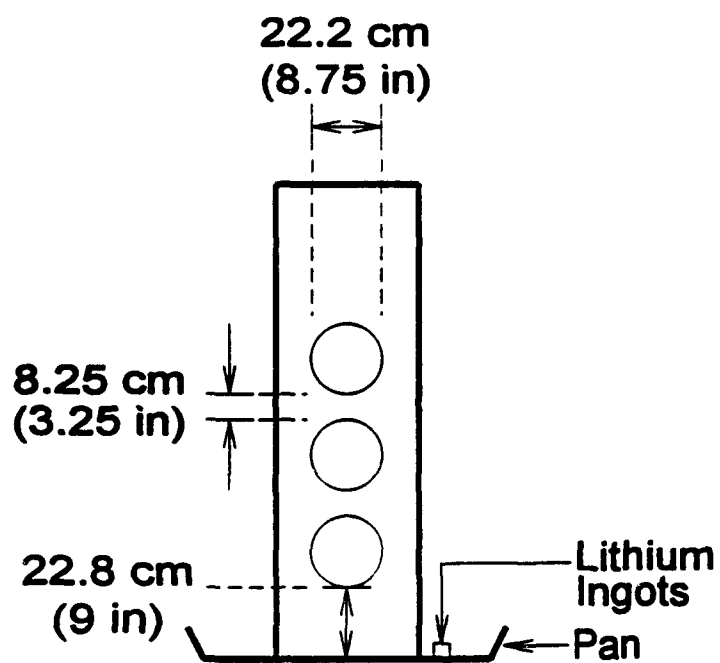

Fig. 5 - Simulated torpedo rack

RESULTS AND DISCUSSION

Tests 1 and 2

The results of the static discharge tests are shown in Figure 6 for the Ansul extinguisher and Figure 7 for the Amerex. With the Ansul extinguisher, which uses an argon cartridge, the copper powder was thrown a distance of approximately 0.9 - 1.8 m (3 - 6 ft). The discharge was not a smooth continuous stream for a set distance, but rather, a succession of puffs of copper powder over the entire 30-second discharge time. The limited throw distance of only 0.9 - 1.8 m (3 - 6 ft), as compared with 4.6 - 6.1 m (15 - 20 ft) for other shipboard extinguishers, and the puffing nature of the discharge highlight the need for special training with a copper powder extinguisher. Otherwise, the operator might conclude that the extinguisher is malfunctioning and go for a replacement.

Initially, the Amerex extinguisher failed to discharge, apparently due to packing of the copper powder. The extinguisher was then dropped onto the concrete surface several times to dislodge the powder, after which it discharged properly. The discharge time for the Amerex extinguisher, as shown in Figure 7, was about 50 percent longer than for the Ansul extinguisher. Also, the discharge of the Amerex extinguisher, which is continuously under argon pressure, was much smoother than the Ansul extinguisher. The wand was in place for this test.

The apparent packing problem with the prepressurized (Amerex) extinguisher as compared with the smooth discharge of the cartridge-type (Ansul) bears further investigation if the copper powder extinguishers are to be adopted for shipboard use.

Ansul
15 Mar 1994

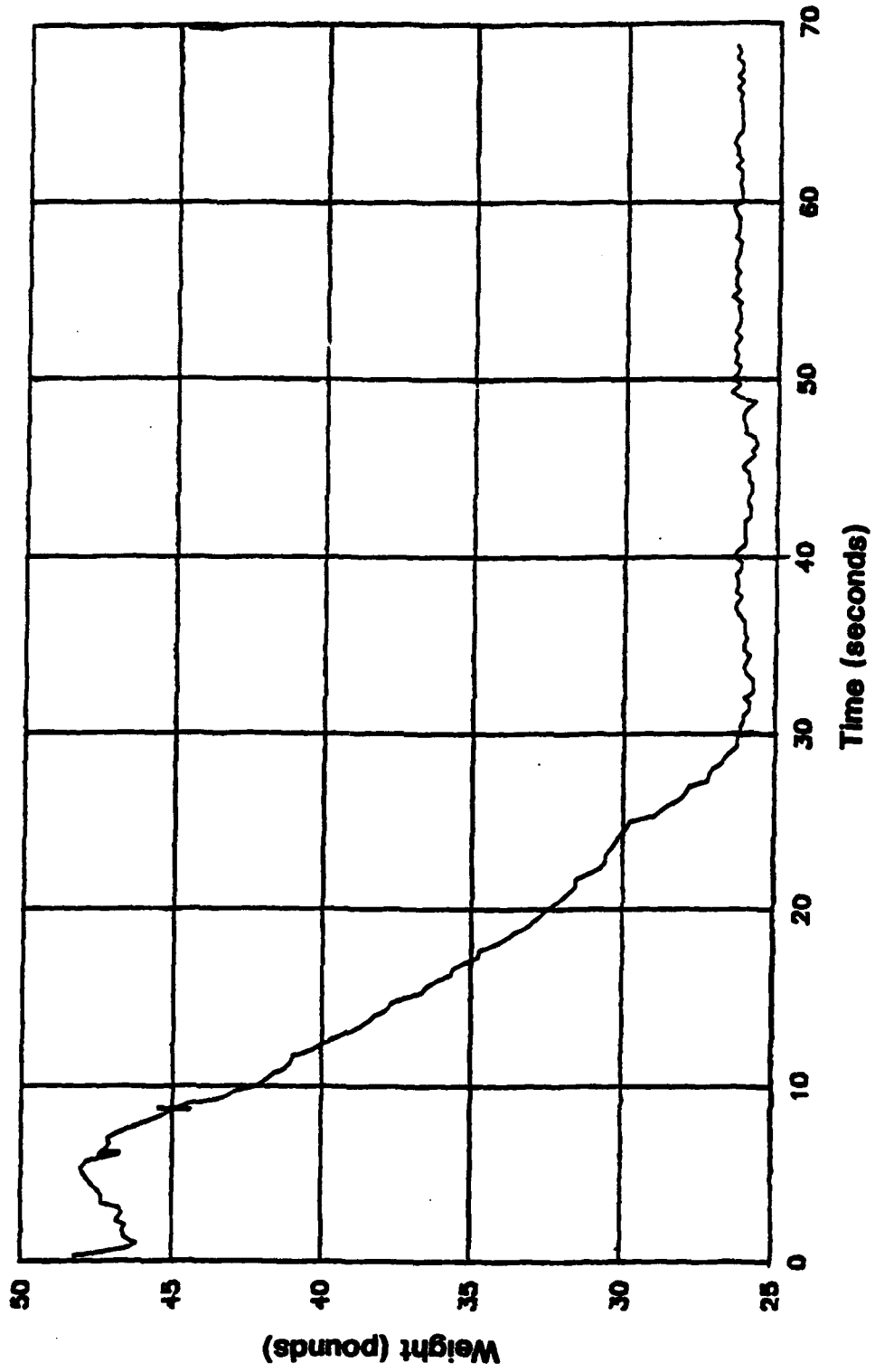

Fig. 6 - Discharge curve for Ansul copper powder extinguisher

Amerex
15 Mar 1994

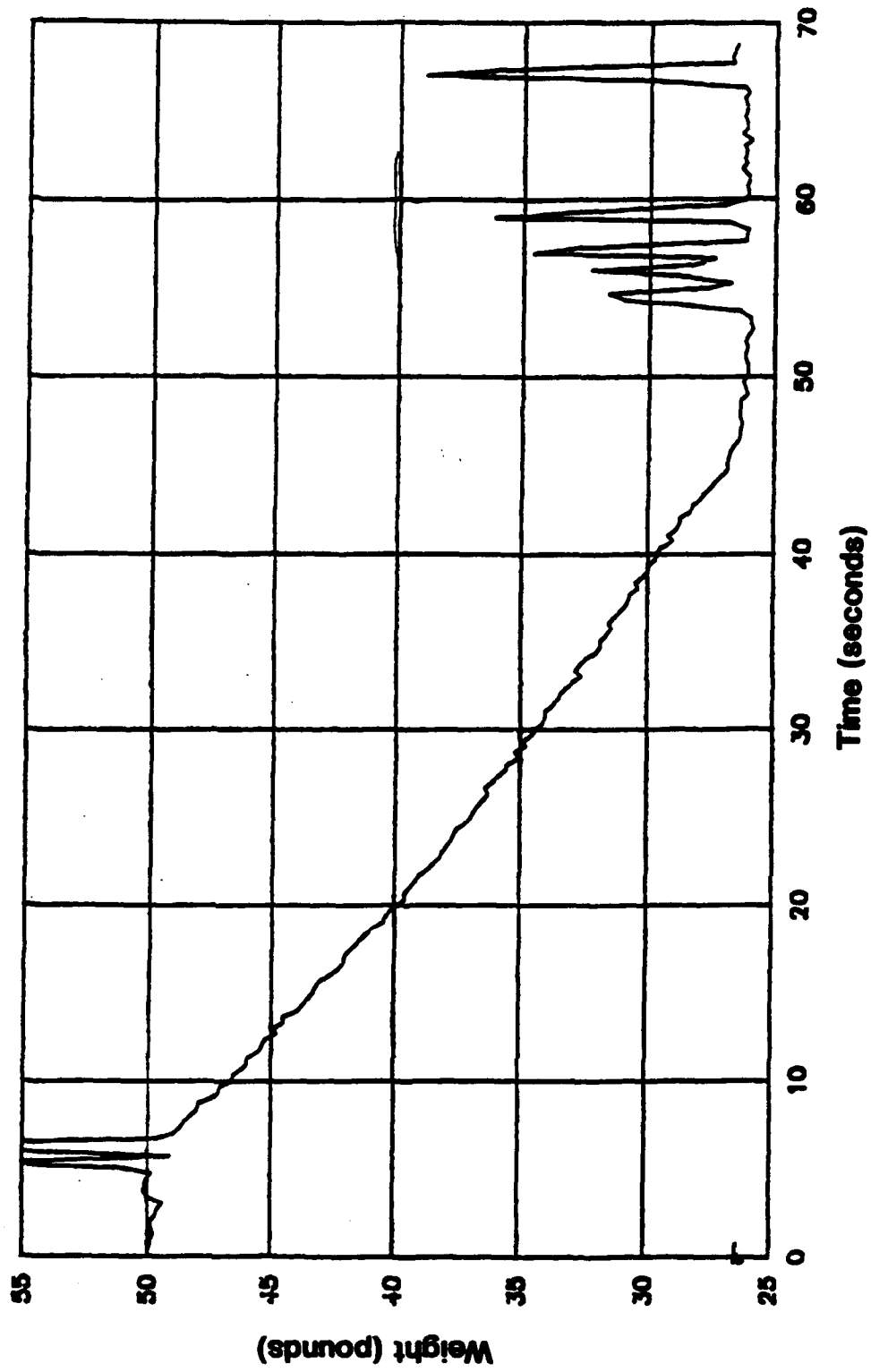

Fig. 7 - Discharge curve for Amerex copper powder gusher

Test 3

In this test, a single, 0.9 kg (2 lb) ingot of lithium was ignited in a steel pan with an acetylene torch. The lithium was melted and ignited in about 22 minutes. Though the burning lithium emitted considerable heat, light and smoke, the flame height was very low, resembling burning charcoal. The products of this combustion, lithium oxide and lithium hydroxide, are toxic [1, 3], and hence, breathing apparatus is required in approaching this fire.

A single Ansul extinguisher was used to extinguish the fire. The extinguishment occurred when the copper powder completely covered the lithium, which took about 30 seconds. The copper formed a hard crust over the burning lithium. A total of approximately 10.4 kg (23 lb) of copper powder was used or about 5.2 kg (11.5 lb) of copper per 0.45 kg (1 lb) of lithium. The recommended application rate is 4.5 kg (10 lb) of copper per 0.45 kg (1 lb) of lithium. Figure 8 provides a photograph of the extinguished lithium.

Test 4

Test No. 4 consisted of an attempt to ignite 0.9 kg (2 lb) of lithium using a JP-4 fuel fire. The JP-4 burned for about 8 minutes at which time, the lithium was melted but only partially ignited. The acetylene torch was used to complete the ignition of the molten lithium. The maximum temperature on the underside of the stainless steel pan prior to extinguishment was $\sim 593^{\circ}\text{C}$ ($\sim 1100^{\circ}\text{F}$). The first Ansul extinguisher immediately extinguished the majority of the lithium, but in some areas, hot spots did recur fairly soon. A second Ansul was used to extinguish these spots. The hot spots appeared to be high areas which needed to have the copper powder built up around the spot to complete extinguishment. A total of ~ 23 kg (~ 50 lb) of copper powder was used, primarily because of the difficulty in extinguishing the hot spots. After a cool down period, small amounts of water were applied to the crust, as well as the torch, and



Fig. 8 - Copper powder over lithium

larger amounts of water simulating a gentle rain. No reignition occurred, and only some small reactions were noted with the initial application of water droplets.

Test 5

In this test, two 0.9 kg (2 lb) lithium ingots were ignited in the stainless steel pan using the torch as the ignitor. A pool of about 0.45 - 0.6 m (1.5 - 2 ft) diameter was formed. The maximum temperature on the underside of the pan prior to extinguishment was $\sim 557^{\circ}\text{C}$ ($\sim 1035^{\circ}\text{F}$). The first Amerex extinguisher immediately extinguished the fire; however, hot spots did occur. A second Amerex was used to extinguish these areas. Approximately 21.8 kg (48 lb) of copper powder was used. After a short cool down, the residue was broken with a shovel, revealing a small amount of unreacted lithium, which then began to react with the air, producing a white smoke (lithium oxide and hydroxide).

Test 6

This test consisted of burning four, 0.9 kg (2 lb) lithium ingots. The resultant pool of burning lithium was about 0.6 m (2.5 ft) in diameter. The first Amerex extinguished about 2/3 of the pool, and the second Amerex extinguished the remaining pool, but five hot spots remained. These spots continued to grow larger with time, and an Ansul extinguisher was used on these areas. The fire appeared out, but about five hot spots recurred after ~ 2 -3 minutes and slowly grew larger, so additional copper powder was applied. A total of 35.4 kg (78 lb) of copper powder was required to complete extinguishment. Temperatures in the white hot areas of the burning lithium were measured to be $\sim 982^{\circ}\text{C}$ ($\sim 1800^{\circ}\text{F}$), which is above the flash point of lithium (871°C (1600°F)), and temperatures in the molten pool were measured to be ~ 316 - 427°C (~ 600 - 800°F).

Test 7

In this test, an 203 mm (8-in.) diameter pipe was used to simulate a torpedo. The pipe was placed 102 mm (4-in.) above a pan containing four 0.9 kg (2 lb) lithium ingots.

The lithium was ignited in the pan, and the first Amerex extinguisher was used. Most of the pool fire was rapidly extinguished; however, the presence of the pipe produced a shadowing effect on the lithium directly under the pipe, effectively limiting the amount of powder reaching the lithium. As a result, the lithium directly under the pipe was not extinguished. A second Amerex was used, but it failed to discharge. An Ansul extinguisher was then used to extinguish the remaining pool, but several hot spots remained. A second Ansul was used; however, a couple of small hot spots remained. Approximately, 4.5 kg (10 lb) of copper powder was applied to the hot spots via a shovel to complete extinguishment. A total of ~ 42 kg (~ 92 lb) of copper powder was used.

Test 8

Test No. 8 consisted of a three-dimensional fire, in which two, 0.9 kg (2 lb) lithium ingots were placed in the pipe above the pan and when ignited were permitted to drip onto the two, 0.9 kg (2 lb) lithium ingots in the pan below. The lithium ingot in the pan was ignited using the torch, and then the lithium in the pipe was melted/ignited. The burning lithium ran out of the hole and onto the burning pool below. The pool fire in the pan was extinguished first followed by the lithium on the underside of the pipe. The lithium inside the pipe was difficult to extinguish due the capability of getting copper powder to the lithium. During the application of an Ansul extinguisher to the inside of the pipe, molten lithium was blown out of the pipe, and the lithium reacted violently with the concrete pad. The lithium inside the pipe was finally extinguished using copper powder applied via a shovel. A total of ~ 69 kg (~ 153 lb) of copper powder was used.

Test 9

In this test, four, 0.9 kg (2 lb) lithium ingots were placed in a steel pan inside a 2.4 x 2.4 x 2.4 m (8 x 8 x 8 ft) compartment. A simulated torpedo rack was installed over the top of the pan, and the lithium was ignited via the torch. After approximately 8 - 9 minutes, the lithium was melted and ignited. The diameter of the burning pool was ~ 0.76 m (~ 2.5 ft). Initially, an Ansul extinguisher was applied to the burning lithium.

The firefighter applied the extinguisher from outside the doorway, although he did lean into the compartment during application. The Ansul extinguisher extinguished about 1/2 of the burning lithium; however, the portion of the pool furthest away was not extinguished. A second Ansul extinguisher was applied, and it extinguished the majority of the lithium; however, hot spots did remain on the far side of the pan. Two Amerex extinguishers were used to complete extinguishment of the remaining hot spots. Approximately five minutes after the last extinguisher was applied, a hot spot appeared, and it was extinguished with copper powder applied via a shovel. During this test, smoke levels due to the burning lithium were such that the firefighter had visibility problems during the initial attack. The maximum temperature on the underside of the test pan was $\sim 556^{\circ}\text{C}$ ($\sim 1033^{\circ}\text{F}$). A total of 52 kg (114 lb) of copper powder was used.

Test 10

Test No. 10 consisted of burning two, 0.9 kg (2 lb) lithium ingots in an aluminum pan that was placed inside a steel pan. The objective was to get a rough determination of how well an aluminum deck would hold up in the presence of a lithium fire. The aluminum pan was 36 x 46 x 10 cm (14 x 18 x 4 in.) and constructed of 6.4 mm (0.25 in.) thick aluminum. The carbon steel pan which contained the aluminum pan was 58 x 58 x 10 cm (23 x 23 x 4 in.) and constructed of 4.8 mm (3/16-in.) thick carbon steel. The lithium ingots were placed into the aluminum pan and ignited. The temperature on the underside of the aluminum pan was monitored throughout the test, and after melt through, the underside steel pan temperatures were monitored. Temperatures of $\sim 1038^{\circ}\text{C}$ ($\sim 1900^{\circ}\text{F}$) were attained at the surface of the burning lithium while temperatures in the lithium pool were $\sim 316^{\circ}\text{C}$ ($\sim 600^{\circ}\text{F}$). Approximately 12 minutes into the test, the aluminum pan began to bow on the sides, and about 14 minutes into the test, the pan melted through and the burning lithium began to fall into the steel pan. Two Amerex extinguishers were used to extinguish the burning lithium. Approximately 23 kg (50 lb) of copper powder were used.

A summary of the test results is given in Table 2.

Table 2. Copper Extinguisher Test Summary

Test No.	Amount of Lithium (kg (lb))	Amount of Copper Powder Applied (kg (lb))	Ratio of Copper Powder to Lithium	Remarks
1	0 (0)	0 (0)	N/A	Static Discharge test
2	0 (0)	0 (0)	N/A	Static Discharge test
3	0.9 (2)	10 (23)	11.5	
4	0.9 (2)	23 (50)	25.0	
5	1.8 (4)	22 (48)	12.0	
6	3.6 (8)	35 (78)	9.8	
7	3.6 (8)	42 (92)	11.5	20 cm (8 in.) diameter obstruction over pan
8	1.8 (4) in pan 1.8 (4) in pipe	69 (153)	19.1	20 cm (8 in.) diameter pipe with 1.9 cm (0.75 in.) hole over pan with lithium in pipe
9	3.6 (8)	52 (114)	14.3	Pan in compartment with simulated rack
10	1.8 (4)	23 (50)	12.5	Aluminum pan and steel pan

FINDINGS

Based on the tests conducted, the following findings are made:

- Under ideal conditions, i.e., unobstructed access to the fire, copper powder will extinguish burning lithium when applied at the recommended rate of 4.5 kg (10 lb) of copper per 0.45 kg (1 lb) of lithium. The copper powder forms a fairly hard crust on the surface of the burning lithium which excludes air, thereby quenching the combustion reaction. The crust can be broken especially while still hot, exposing molten lithium which, if it is still above its flash point, can reignite. If the extinguished residue is allowed to cool, it is very difficult to break the crust, and when it is broken, very little pure lithium remains.
- In areas where there are peaks on the surface of the burning lithium, the copper powder must be built up around the spot. Since the copper powder tends to run off elevated spots, considerably more powder is required for complete extinguishment under these conditions.
- The extinguishment is not just a function of how many pounds of lithium are used, but is also a function of the diameter or size of the molten pool that is formed by the lithium and is dependent upon the formation of elevated areas or peaks.
- Obstructions cause serious problems in extinguishment. The copper powder must be applied directly to the burning lithium, it will not flow or spread by itself. In tests where the firefighter can move around the fire, extinguishment is fairly easy. But, if access to the fire is restricted by obstructions, then extinguishment is more difficult and considerably more copper powder is required than the 4.5 kg (10 lb) per 0.45 kg (1 lb) of lithium recommended by the manufacturer.

The burning lithium produces a white, caustic smoke that, when confined, can obscure the firefighters' vision.

Care must be taken when refilling the copper powder extinguishers. This is especially true with the Amerex extinguishers. It is recommended that O-rings and seal be replaced when refilling and care should be taken to keep moisture away from the copper powder.

Burn through time for aluminum will be a function of the size and depth of the burning lithium pool. The thinner the pool, the sooner the temperature will rise, and the aluminum melt through.

Burning lithium will not burn through carbon or stainless steel.

SUITABILITY FOR SHIPBOARD USE

Materials of Construction/Corrosion Resistance

The Ansul extinguisher is a duplicate of the Ansul PKP portable extinguishers already in the Fleet with the exception that an argon cartridge is used instead of CO₂. Similarity of cartridges could cause confusion with the potential for disastrous results. The Amerex extinguisher is constructed of steel and would appear to be of acceptable construction; however, shipboard vibration would almost surely result in packing of the copper powder.

In considering shipboard use, the primary concern is insuring that the copper powder does not absorb moisture, which will react with the lithium. Therefore, provisions will have to be made for the storage of copper powder aboard ship and precautions taken to preclude moisture when refilling copper extinguishers.

Logistics

These tests have shown that, even under ideal conditions, about 4.6 kg (10 lb) of copper powder is needed to extinguish 0.45 kg (1 lb) of lithium. Accordingly, a minimum of eight extinguishers would be required per torpedo since generally 11 kg (25 lb) is actually discharged from a single extinguisher. With an average loaded weight of 22.7 kg (50 lb), this adds 182 kg (400 lb) for only eight extinguishers. If you add one recharge for each of these, the total weight will be approximately 318 kg (700 lb). Adding this much weight to an already weight critical ship for a minimum protection of one torpedo is a questionable return on the investment.

Range

Under zero wind conditions, the maximum range for the copper extinguishers is 0.9 - 1.5 m (3 - 5 ft). Obviously, for flight deck operations where wind velocities are in the range of 15-30 knots, the tip of the extinguisher would have to be directly above the burning lithium for effective application and extinguishment.

Need for Special Training

Training on the use of this extinguisher is important because, unlike the other portable firefighting extinguishers used by the Navy, this extinguisher does not project the powder 4.6 to 6.1 m (15 to 20 ft) but rather only 0.9 to 1.5 m (3 to 5 ft). An untrained individual would probably conclude that the extinguisher was not operating properly and discard it.

Live fire training would be impractical because of the high cost (\$45/pound) and hazard of handling of the lithium, and the high cost of copper powder (\$2-3/pound) and argon cartridges (\$60 each). Thus, a single, 0.9 kg (2 lb) lithium training fire would cost \$150 to \$175, not including the cleanup costs. If you conduct two demonstrations per

day, five days a week at four schools, the cost would be \$350,000 per year. If you only demonstrate the extinguisher, the cost is still \$250,000 per year.

Size, Weight, and Ease of Handling

The Ansul and the Amerex extinguishers both weigh approximately 20.4 kg (45 lb) when charged. The Ansul, which is a duplicate of the PKP extinguisher, is easy to handle, charge, and use. The Amerex with its longer hose allows more flexibility.

Other Salient Features

Because of the lack of reach necessary for stand-off firefighting, the copper powder portables could be defined as moisture proof containers for the powder. In fact, a barrel of copper powder and two shovels are likely to be more effective in extinguishing a lithium fire than ten portables because they can deliver more powder per minute and deliver powder without the interruption of changing extinguishers.

REFERENCES

1. "Advance Change Notice (ACN) 1/A to Naval Ships Technical Manual, NAVSEA S9086 S3-STM-010, Chapter 555," Naval Sea Systems Command, Ltr Ser 03G2/016, March 11, 1994, p. 138.
2. *Fire Protection Guide on Hazardous Materials*, Tenth Edition, National Fire Protection Association, 1991, pp. 491M - 120.
3. Sax, N.I., *Dangerous Properties of Industrial Materials*, Second Edition, Reinhold Publishing Corporation, New York, 1963, p. 940.