

AD-A281 580



4

2

ADST/WDL/TR-93-003274

ADST
System Test Report
for the
Rotary Wing
Aircraft Airnet Aeromodel and Weapon
Model Merge with the ATAC II Baseline

Loral Advanced Distributed Simulation
12151-A Research Parkway
Orlando, Florida 32826

January 20, 1994

Contract No. N61339-91-D-0001
Delivery Order No. 0014
CDRL A007

Prepared for

Simulation Training and Instrumentation Command
Naval Air Warfare Center
Training Systems Division
12350 Research Parkway
Orlando, FL 32826-3224

DISTRIBUTION STATEMENT A
Approved for public release
Distribution Unlimited

LORAL DTIC QUALITY INSPECTED 1

reduce an
y satisfied
more an
g function

the proble
ammunition

re of am
the impact
performing
of the sim

of the pro
e-armed
for the 20
eful for th
it must be

that the
SM we
of the
n all
le screen
ire. The
type.

COPY

DTIC
SELECTE
JUN 27 1994
S B D

ADST/WDL/TR-93-003274

**ADST
System Test Report
for the
Rotary Wing
Aircraft Airnet Aeromodel and Weapon
Model Merge with the ATAC II Baseline**

**Loral Advanced Distributed Simulation
12151-A Research Parkway
Orlando, Florida 32826**

January 20, 1994

**Contract No. N61339-91-D-0001
Delivery Order No. 0014
CDRL A007**

Prepared for

**Simulation Training and Instrumentation Command
Naval Air Warfare Center
Training Systems Division
12350 Research Parkway
Orlando, FL 32826-3224**

LORAL

REPORT DOCUMENTATION PAGE			Form approved OASD No. 0704-0188
Public reporting burden for this collection of information is estimated to average 1 hour per response, including the time for reviewing instructions, searching existing data gathering and maintaining the data needed, and completing and reviewing the collection of information. Send comments regarding this burden estimate or any other aspect of this collection of information, including suggestions for reducing this burden, to Washington Headquarters Service, Directorate for Information Operations and Reports, 1215 Jefferson Davis Highway, Suite 1204, Arlington, VA 22202-4302, and to the Office of Management and Budget Project (0704-0188), Washington, DC 20503.			
1. AGENCY USE ONLY (Leave blank)	2. REPORT DATE 20 January 1994	3. REPORT TYPE AND DATES COVERED Version "original"	
4. TITLE AND SUBTITLE System Test Report for the Rotary Wing Aircraft Airnet Aeromodel and Weapons Model Merge with the ATAC II Baseline		6. FUNDING NUMBERS Contract No. N61339-91-D-0001 Delivery Order # 0014 CDRL A007	
5. AUTHOR(S) Almaaza, Joe; Thompson, Lynn; Kruck, Mary			
7. PERFORMING ORGANIZATION NAME(S) AND ADDRESS(ES) Loral Systems Company ADST Program Office 12151 - A Research Parkway Orlando, FL 32826		8. PERFORMING ORGANIZATION REPORT NUMBER ADST/WDL/TR-93-003274	
9. SPONSORING/MONITORING AGENCY NAME(S) AND ADDRESS(ES) Simulation, Training and Instrumentation Command STRICOM Naval Air Warfare Center, Training Systems Division 12350 Research Parkway Orlando, FL 32826-3275		10. SPONSORING ORGANIZATION REPORT	
11. SUPPLEMENTARY NOTES			
12a. DISTRIBUTION/AVAILABILITY STATEMENT Approved for public release; distribution is unlimited.		12b. DISTRIBUTION CODE A	
13. ABSTRACT (Maximum 200 words) Documents the results and corrective actions of the AIRNET/ATACII test activities which were conducted at the Ft Rucker, AL Aviation Training Facility during the periods of 8-12 February 1993 and 9-18 August 1993.			
14. SUBJECT TERMS		15. NUMBER OF PAGES	
		16. PRICE CODE	
17. SECURITY CLASSIFICATION OF REPORT UNCLASSIFIED	17. SECURITY CLASSIFICATION OF THIS PAGE UNCLASSIFIED	17. SECURITY CLASSIFICATION OF ABSTRACT UNCLASSIFIED	18. LIMITATION OF ABSTRACT UL

TABLE OF CONTENTS

SECTION 1 - SUMMARY1

1.0 PURPOSE.....1

1.1 APPLICABLE DOCUMENTS.....2

1.2 TEST IDENTIFICATION2

1.3 TEST ATTENDEES.....3

1.4 TEST READINESS REVIEW4

1.5 TEST CONDUCT.....5

SECTION 2 - TEST RESULTS7

2.0 AIRNET/ATAC II FORMAL TEST RESULTS.....7

2.1 Exercise "B" (Test Cases #3 and #5)..... 7

2.2 Exercise "C" (Test Cases #4 and #6)8

2.3 Exercise "A" (Test Cases #1 and #2)9

SECTION 3 - CORRECTIVE ACTIONS11

3.0 ANOMALY IDENTIFICATION11

3.1 STATUS AND CORRECTIVE ACTIONS.....12

APPENDIX14

APPENDIX A A-1

APPENDIX B B-1

APPENDIX C C-1

Accession For	
NTIS GRA&I	<input checked="" type="checkbox"/>
DTIC TAB	<input type="checkbox"/>
Unannounced	<input type="checkbox"/>
Justification	
By _____	
Distribution/	
Availability Codes	
Dist	Avail and/or Special

LIST OF ILLUSTRATIONS

Figure 1.0-1 Combined MIPS/MASSComp MCC and RWA Configuration.....1

LIST OF TABLES

Table 1.4.1 Exercise Requirements Distribution.....4
Table 1.4-2 Problems Prior to Start of Formal Test Phase5
Table 1.5-1 Formal Test Phase Schedule5
Table 1.5-2 Deliverable Software Components.....6
Table 1.5-3 Additional Documented Problems.....6
Table 3.0-1 Category 1 - LADS PMO Direction.....11
Table 3.0-2 Category 2 - Investigation/Debug Required11
Table 3-1 Field Test Report Status/Corrective Action.....13

SECTION 1 - SUMMARY

1.0 PURPOSE

The purpose of this report is to document the results of the AIRNET/ATAC II test activities which were conducted at the Ft. Rucker Aviation Training facility during the periods of 8 Feb. - 12 Feb. 1993, and 9 Aug. - 18 Aug. 1993. The first period of verification was an informal test period in which the AIRNET Upgrades were verified at the Ft. Rucker training facility on the actual RWA training configuration. The second period of verification consisted of formally verifying the AIRNET Upgrades in conjunction with the merge of the upgrades on the ATAC II baseline. The Government witnessed the formal verification period and this report formally documents those events pertinent to this Delivery Order. The AIRNET RWA Acceptance Test Plan, dated 1 Nov., 1992, and the System Integration Plan for the RWA Airnet Aeromodel and Weapons Model Merge With The ATAC II Baseline, dated 26 April, 1993, describe in detail the tests and integration process implemented for completion of this effort. The test was considered successful with only eleven (11) discrepancies noted, none critical, and the new baseline was deemed acceptable and ready for operational use at the Ft. Rucker training facility. Figure 1.0-1 reflects the major components of the Ft. Rucker training facility configuration. The Digital Message Communications Console (DMCC) was not directly connected to the SIMNET network during this test. Only six of the eight RWA units were available during the formal test verification phase at the Ft. Rucker facility.

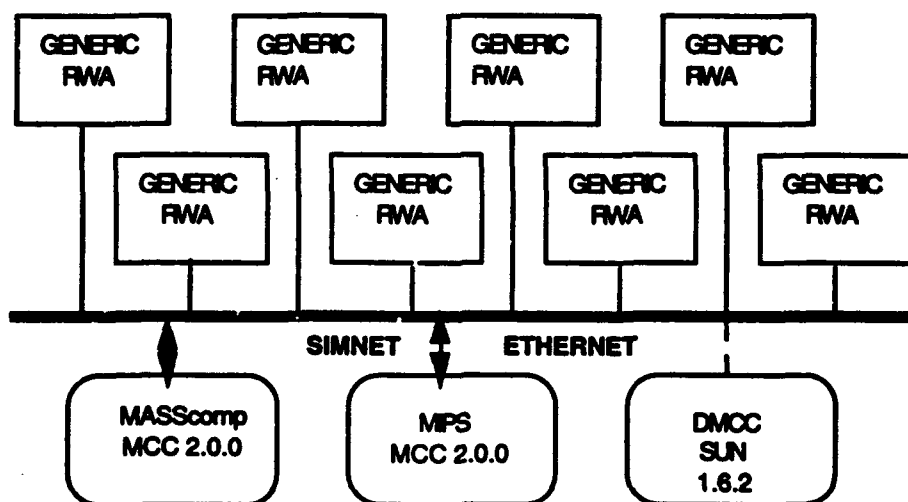

Figure 1.0-1 Combined MIPS/MASSComp
MCC and RWA Configuration

1.1 APPLICABLE DOCUMENTS

The following documents are applicable to the extent referenced herein and where not specifically referenced are used as sources of additional information.

- a. Recommended Spares and Support Equipment, DI-V-30801.
- b. MCC Operator's Manual, DI-MISC-80711.
- c. AIRNET Data Handbook, March 14, 1986.
- d. System Specification for the Rotary Wing Aircraft AIRNET Aeromodel and Weapons Model Conversion, dated 6 June 1992.
- e. Statement of Work for the Acquisition of Rotary Wing Aircraft AIRNET Upgrades, dated 30 March 1992.
- f. DI-DRPR-81002, Developmental Design Drawings and Associated Lists.
- g. AIRNET RWA Acceptance Test Plan, dated 1 Nov. 1992.
- h. ADST/AIRNET RWA Test Procedures (ADST/WDL/TR-92-003029):
 - 1) Procedure No. Exercise "A", Witness Dated 8-18-93.
 - 2) Procedure No. Exercise "B", Witness Dated 8-18-93.
 - 3) Procedure No. Exercise "C", Witness Dated 8-18-93.
- i. Software Requirements Specification for the Air to Air Combat (ATAC II) AIRNET Experiment, Rev. 2.0, dated 4 Oct. 1992.
- j. System Integration Plan For The Rotary Wing Aircraft Airnet Aeromodel and Weapons Model Merge with the ATAC I Baseline, dated 26 April 1993.

1.2 TEST IDENTIFICATION

There were initially a total of six (6) test cases described in the AIRNET RWA Acceptance Test Plan. These were identified as follows based on the functions which were being tested in each and the requirements allocations made to each test case:

- a. Test Case #1 - MCC Comanche Support Upgrade
- b. #2 - MCC Digital Message/Communications
- c. #3 - RWA Flight Model Upgrade
- d. #4 - Improved Collective Mount
- e. #5 - RWA Weapons Model Upgrade
- f. #6 - Kill Communications

During the process of developing the procedures it became obvious that a combing of the test cases in a logical manner could be accomplished to provide for a more effective and efficient test phase. Therefore, an analysis was performed to combine the test cases into defined step-by-step exercises which would better replicate training scenarios used during the Ft. Rucker training operations. This analysis resulted in combining of the above six test cases into three defined exercises.

The exercises and relationship to the test cases were defined as follows:

- a. Exercise "A" - Test Cases #1 and #2
- b. Exercise "B" - Test Cases #3 and #5
- c. Exercise "C" - Test Cases #2 and #4

The requirements allocation for each of the above exercises are listed by test in Appendix A, and correspondingly identified in each test procedure of Appendix C of this document. Appendix A also identifies those requirements which were allocated to the Inspection/Analysis method of verification. The reports supporting the verification of these requirements are also provided as part of each procedure package in Appendix C.

All problems were documented through the ADST SP/CR form and provided to the Government at the end of the test period. These reports are also provided as Appendix B of this document and are identified in the corrective action plan in this document.

1.3 TEST ATTENDEES

The following personnel attended the AIRNET/ATAC II formal tests during the week of 16 August 1993.

- a. Bryant Lafoy (STRICOM)
- b. Major Hawes (U.S. Army)
- c. Capt. Churn (U.S. Army)
- d. Capt. Francesconi (U.S. Army)
- e. W.O. Mason (U.S. Army)
- f. John Miller (LTTS)
- g. Jay Anton (LTTS)
- h. Juan Vela (LTTS)
- i. Randy Kubik (LADS)
- j. Joe Almanza (LWDL)
- k. Peter Desmeules (LWDL)
- l. William Jaques (LWDL)

1.4 TEST READINESS REVIEW

The formal tests were preceded by a Test Readiness Review meeting held on 16 August, 1993. Participants were briefed on the following agenda items:

- a. OBJECTIVE
- b. AIRNET/ATAC II ENHANCEMENTS
- c. TEST CONFIGURATION/TEST TOOLS
- d. REQUIREMENTS ALLOCATION
- e. PROCEDURE REVIEW
- f. TEST SCHEDULE
- g. POST-TEST REVIEW ACTIONS

The Collective Mount modification was installed during the February, 93 time frame and had been in operational use during this interval. A problem had been identified with its performance and subsequently resolved during this final test phase. This problem was documented as SP/CR FTR-1 and closed during this test phase.

The Kill Communications modification was installed in RWA units 82, 83, and 87 during this test phase. The installation yet to be completed was documented as SP/CR FTR-10 and reflects that the remaining 7 RWA units require the installation of the Kill Communications modification.

The allocation of requirements was presented to support the explanation of how the ATAC II requirements were selected for verification during this effort. All requirements were verified through either the demonstration/test method or the inspection/analysis method. The requirements allocated to the inspection/analysis method were verified through the reports prepared and submitted in conjunction with each test procedure. The distribution of the requirements over the three exercises were identified and are presented below in Table 1.4-1:

Table 1.4.1 Exercise Requirements Distribution

Exercise	Demonstration/Test (AIRNET/ATAC II) Req.	Inspection/Analysis Req. (Reports)
"A"	61/29	25(6)
"B"	42/0	18(7)
"C"	17/11	12/10(5)
TOTALS	120/40	55/10(18)

Seven (7) total problems were surfaced and documented during the pre-formal test period conducted during week of 9 August, 1993. These problems were identified and presented at the Test Readiness Review. The seven problems documented prior to the start of the formal test phase (Table 1.4-2) were as follows:

Table 1.4-2. Problems Prior to Start of Formal Test Phase

FTR-#	(SP/CR#)	TITLE
1	(214)	Collective Mount
2	(212)	Bad WYSE Terminal
3	(215)	DMCC Termination
4	(205)	30 MM Re-Supply
5	(206)	20 MM/HYDRA Re-Supply
6	(207)	MIPS SCC Application Size
7	(208)	WYSE Terminal Font

The customer requested that an "in-brief" and "out-brief" be conducted prior to, and upon completion, of each exercise. This was agreed to by all parties and was adhered to during the formal test phase. A joint agreement was also reached in how to address the DMCC portions of the tests. The DMCC functionality is a completely separate function which would be demonstrated outside the RWA cab units. The agreement was made to execute the DMCC portion of each test after the RWA portion of each test was completed. This provided for a smoother test flow and more efficient test schedule.

1.5 TEST CONDUCT

All tests were formally witnessed by the Government and the user of the AIRNET RWA training operation. Section 2 of this report describes each test, test results, and any test anomalies encountered.

The formal test phase was initiated following the TRR on 16 August, 1993. The tests were conducted in accordance with the following schedule (Table 1.5-1):

Table 1.5-1. Formal Test Phase Schedule

DATE	TEST CONDUCTED
8/16/93	Exercise "B"
8/17/93	Exercise "C"
	Exercise "A"
8/18/93	Final Post Test Review

The tests were conducted utilizing the following deliverable software components (Table 1.5-2):

Table 1.5-2. Deliverable Software Components

SOFTWARE IDENTIFIER	VERSION ID
AIRNET MIPS MCC Phantom	2.0.0
AIRNET MAC SCC	2.0.0
SIMNET MASSCOMP MCC	2.0.0
SIMNET MAC SCC	2.0.0
SIMNET MAC Admin/Log	2.0.0
GT Operating System	GT 4.7 (Apr. 9, 1991)
GT Real Time S/W	rttgr 5.7
Rotary Wing Aircraft (RWA)	1.1.0
Digital Message Communications Console (DMCC)	1.6.2
Missile Server S/W	1.0 (Dec. 11, 1992)

Four (4) more problems were documented as a result of the observed tests and following discussions at the "out-brief" reviews. They are identified here and described in more detail, as applicable, in the next Section of this document:

Table 1.5-3. Additional Documented Problems

FTR-#	(SP/CR#)	TITLE
8	(209)	Minimum Placement Distance
9	(211)	New RWA S/W not loaded on all units
10	(213)	Install Remaining Kill Comm Mod
11	(210)	Screen Freeze on Firing HYDRA MPSM

Resolution and closure of all documented problems are provided in Section 3 of this document.

SECTION 2 - TEST RESULTS

2.0 AIRNET/ATAC II FORMAL TEST RESULTS

The AIRNET/ATAC II tests are identified here in the order in which they were executed. A brief description is provided for each test, followed by any problems encountered and a description of the problem. The tests were conducted on 16-17 Aug. 1993, at the Ft. Rucker training facility. All requirements validated during this test phase are identified in Appendix A of this document. The applicable requirements are also identified in each respective test procedure provided as part of Appendix C of this document.

2.1 Exercise "B" (Test Cases #3 and #5)

Test cases #3 and #5 were combined to demonstrate the requirements allocated to these functions in one exercise. The primary functions allocated to these test cases were as follows:

- a. Test Case #3 - RWA Flight Model Upgrade
- b. Test Case #5 - RWA Weapons Model Upgrade

The test consisted of allocating one rotary wing aircraft at a specific location and establishing the baseline flight and weapons model characteristics. The aircraft is then "flown" to a specific location under controlled conditions and weapons fired noting the characteristics of the weapons as they are fired. The simulator is then halted to modify the flight and weapons model files to known values. The flight path and weapons firing sequences are then repeated under the same controlled conditions. The difference in the flight and weapons characteristics between the two "flights" verify that the changes took effect. This verifies the table driven requirements allowing for the parameters of these various files to be modified through keyboard input. This test was successfully completed and all requirements allocated to this exercise were successfully verified.

Problems/Resolutions

None encountered during execution of test steps.

2.2 Exercise "C" (Test Cases #4 and #6)

Test cases #4 and #6 were combined to demonstrate the requirements allocated to these functions in one exercise. The primary functions allocated to these test cases were as follows:

- a. Test Case #4 - Improved Collective Mount
- b. Test Case #6 - Kill Communications

This test consisted of loading the new RWA software on all eight RWA units and verifying they could all be booted and made operational. Three of the aircraft were then utilized in testing flight, kill communications, and weapons fire functionality. At various points throughout the exercise, the aircraft are flown, crashed intentionally, and reconstituted. The communications function is verified for its various states of functionality during this test; ON mode, OFF mode, and AUTO mode. The DMCC portion of this test was conducted out of sequence, at no impact to the test results, and outside the RWA cab compartments. The DMCC functionality was demonstrated utilizing one SUN host terminal and three WYSE terminals connected via their own independent network. The resident Missile Server software was also utilized during this test in demonstrating specific ATAC II requirements related to laser, targeting, and weapons firing involving two different RWA units. This functionality was not demonstrated utilizing the SIMNET network during this test.

The portions of this test requiring all eight RWA units were for the specific following RWA enhancements:

- a. Loading of the new RWA software on all eight units.
- b. Installation of the Kill Communications relay switch on all eight units.
- c. Installation of the Collective Mount on all eight units.

Due to the image generation component of two of the eight RWA units not being available at the Ft. Rucker facility during this time frame, the RWA software was not loaded on the two missing units. This anomaly was documented as FTR-9 and is described below in conjunction with the other problems noted during the execution of this test.

Problems/Resolutions

FTR-08 (SP/CR-209)

This anomaly was noted during this test at step 310 of the procedure. The displacement for two vehicles, when constituted at the same location, is being performed at a distance of 20 meters by the AIRNET software. The requirement 3.2.1.1.1.13 states that the displacement should be at a distance of 33 meters. After discussions with the operations personnel it was concluded that the requirement should be reviewed prior to any planned action on modification to the AIRNET software. The Government has accepted the action to review the requirement before any further direction is provided to resolve this anomaly. This anomaly has been categorized as a minor discrepancy.

Note: Subsequent discussions with the Government in November 1993 resulted in a requirement change to a separation of 20 meters. The test procedures included in this document have been changed to reflect this distance.

FTR-09 (SP/CR-211)

This anomaly was noted prior to the actual execution of the test but has been officially documented as occurring at step 230 of the procedure. The anomaly relates to the actual activation of all eight RWA units, as a Comanche simulator, of which only six were present during the exercise. The two missing RWA units are identified as RWA units ID #84 and #88. The requirement 3.2.1.1.1.10 was therefore only partially verified. The resolution to this anomaly is for the Ft. Rucker personnel to load the new RWA software on the two missing units when they are again resident at the Ft. Rucker facility.

2.3 Exercise "A" (Test Cases #1 and #2)

Test cases #1 and #2 were combined to demonstrate the requirements allocated to these functions in one exercise. The primary functions allocated to these test cases were as follows:

- a. Test Case #1 - MCC Comanche Support Upgrade
- b. Test Case #2 - MCC Digital Message/Communications

The major part of the DMCC functionality was demonstrated during this test. The portions of the test directly related to the DMCC functionality were conducted separately from the "in-cab" portions of the test. The modification to the conduct of this sequence did not affect the results of the test. All remaining DMCC functional requirements were verified during this test.

The RWA "in-cab" portion of this test consisted of first placing ammunition and re-fuel trucks at selected locations. The aircraft is then flown to the selected location where the re-fueling operation takes place and is verified. The aircraft is then flown to a designated target location where weapons are fired and expended in preparation for verification of the re-arming function. The aircraft is then flown to the designated re-arming location. It was at this portion of the test that the anomaly was detected in relation to the re-arming of the 20MM HEI and HYDRAS, weapons types, was noted.

This was officially documented at step 4410 of the test procedure and is formally documented as FTR-5. Requirement 3.2.1.1.2.1 was only partially satisfied as a result of this detected anomaly. Post-test investigations revealed three more anomalies which have been formally documented as related to the re-arming function. These are described below.

Problems/Resolutions

FTR-4 (SP/CR-205)

This problem was documented during the evaluation of the problem associated with FTR-5. It was noted that selections allowed for loading the ammunition carrier no longer reflect the selection for the 30 MM ammunition type. The previous version software allowed for the loading of this type of ammunition and the selection should have remained for the new release. The software defining this selection resides in the MASSCOMP MAC SCC console. The impact is that this ammunition type is not now available for selection when performing the re-supply function. The aircraft must be reconstituted for re-arming of the aircraft for this particular type of weapon.

FTR-5 (SP/CR-206)

This problem was officially documented at step 4410 of the procedure of this exercise. The step identifies four ammunition types to be re-armed during the re-arming process of the vehicle. The re-arming function failed for the 20 MM and the HYDRA ammunition types. The re-arming process was successful for the Hellfire and Stinger missile ammunition types. The impact is that the aircraft must be reconstituted for re-arming of the aircraft for these two types of weapons.

FTR-11 (SP/CR-210)

During the investigative efforts for FTR-5, it was noticed that the screen went into a momentary "freeze", or hesitation, when the HYDRA MPSM weapons type was fired. Further investigation revealed that the "in-air" dispersion of the bombs was not reflected on the screen of the aircraft conducting the firing. The "in-air" dispersion of the bombs was visible when viewing the firing via another vehicle screen which was positioned to view the vehicle performing the HYDRA weapons fire. The explosion of the bombs on the ground was visible as normal for this weapons type.

SECTION 3 - CORRECTIVE ACTIONS

3.0 ANOMALY IDENTIFICATION

The anomalies previously discussed were separated into two categories. The first category (Table 3.0-1) are those anomalies which were addressed by the Ft. Rucker personnel, with LADS PMO direction, and did not require extensive investigative efforts. The second category (Table 3.0-2) are those anomalies which required investigative efforts and were either corrected or left "as is". These actions were discussed with the Government in November 1993. The corrective actions for all items are summarized in Table 3-1 in section 3.1. The Field Test Reports and SP/CR's are listed below for the two categories:

Table 3.0-1. Category 1 - LADS PMO Direction

FTR-#	(SP/CR#)	TITLE
2	(212)	Bad WYSE Terminal
7	(208)	WYSE Terminal Font
9	(211)	New RWA S/W not added on all units
10	(213)	Install Remaining Kill Comm Mod

Table 3.0-2. Category 2 - Investigation/Debug Required

FTR-#	(SP/CR#)	TITLE
4	(205)	30 MM Re-Supply
5	(206)	20 MM/HYDRA Re-Supply
6	(207)	MIPS SCC Application Size
8	(209)	Minimum Placement Distance
11	(210)	Screen Freeze on Firing HYDRA MPSM

3.1 STATUS AND CORRECTIVE ACTIONS

The ATP generated Field Test Reports (FTR) are summarized in Table 3-1 by System Problem/Correction Report (SP/CR). All discrepancies are closed. The Software Maintenance Manual, and Vol's I and II of the Operators Manual have been updated if required, to reflect the corrective actions performed. This test report was also updated to change the test procedure for vehicle separation during placement (SP/CR 209).

SP/CR No.	Submitter Problem Description	Status	Problem Resolution
205	J. Almeraz-FTR 04 The ammo tables reflected on the MASSCOMP MAC (SCC) software does not contain any reference to the SOMM ammo type. Therefore, it cannot be selected for resupply.	Closed	Appropriate files modified (corrected). Discrepancy resolved.
206	J. Almeraz-FTR 05 Masscomp SW does not provide for loading (resupply) of the 20MM or the hydra weapons.	Closed	This discrepancy will be resolved as the newer subsystems-Session Managers-come on line with the DIS Architecture. No significant site operational impacts are evident. The problem is being resolved during operations by reconstituting the simulator. This has the effect of resupplying on-board resources. MCC deliverable documents have been updated to reflect the procedure to resupply via reconstitution.
207	J. Almeraz-FTR 06 The MIPS SCC Software no longer will fit on one floppy disc. The new aimet software application has increased in size and requires 2 floppy discs and therefore a second drive.	Closed	System is presently working with one floppy. Too many Macintosh operating system files were added to the floppy when it was initially set up. The extra files were removed and the application now fits on one floppy. The Software Maintenance Manual was updated to define creation of the floppy disc to define the correct file configuration.
208	J. Almeraz-FTR 07 X-Window server Font is different than the Host DMCC Terminal font.	Closed	Font was changed to -adobe-times-r-normal--140--p-iso8859-1 on line 543 of dmcc/guifcurses/fgon.c
209	J. Almeraz-FTR 08 Aimet Requirement 3.2.1.1.13 states a minimum vehicle placement separation of 33 meters on initialization. The current separation is 20 meters apart.	Closed	The current separation of 20 meters is acceptable to the operational users. The 33 meter requirement was inadvertently used from a requirements document which was developed outside of this Delivery Order. This Aimet Functional Spec was used as a guide only. Since the 20 meter separation is, and has been, the placement separation it is acceptable to the operational users.
210	J. Almeraz-FTR 11 When firing the HYDRA MFSM Ammo type, the screen does not reflect the "in-air" dispersion of the bombs. The screen also heebles and freezes for a split second. The screen does reflect the bombs exploding on the ground.	Closed	Cause of problem was in sub_m73.c file. This is read every time a Hydra rocket is fired. The routine to read a data file for the MFSM munition was in this file, consequently the file read operation conflicted with the real-time operation of the CG. Moved the routine to read the data file out of sub_m73.c to read_hydra.c along with the other data file reads. This causes the data file to be read once on initialization of the simulation.
211	J. Almeraz-FTR 09 The following units were not available during the on-site test phase for verification of the new RWA SW load. GT111 units B09002 and B09003.	Closed	Fully installed on these two units and tested. This discrepancy has been completed by FL Rucker Personnel.
212	J. Almeraz-FTR 02 Wye Terminal (sh OGP11A00167) would not power up correctly. Only makes attempt, screen remains dark.	Closed	Terminal was sent out for repair. Repairs have been completed, terminal has been returned to FL Rucker and was tested and accepted. Power cords were provided and missing keyboard cord replaced.
213	J. Almeraz-FTR 10 No power cords were delivered with Wye terminals. One missing keyboard cord. The IRI Comm Folley Switch has not been installed in the following units: 81, 84, 85, 86, 88	Closed	FL Rucker personnel installed the hardware in the remaining units--complete week ending 21 Aug 93.
214	J. Almeraz-FTR 01 When pulling up on the collective mount, the distances are inconsistent from unit to unit.	Closed	Replaced new "pots" in collective mount mechanism with the original "pots". Completed 21 Aug 93.
215	J. Almeraz-FTR 03 The DMCC X-Window application crashes with a segmentation fault in routine. X Widget to Application Context 0. This occurs randomly--not consistent.	Closed	Problem could not be duplicated.

Table 3-1 Field Test Report Status/Corrective Action

APPENDIX

**System Test Report
for the
Rotary Wing
Aircraft Airnet Aeromodel and Weapon
Model Merge with the ATAC II Baseline**

APPENDIX A

FINAL

VERIFICATION TRACEABILITY MATRIX

APPENDIX A

EXERCISE "A" REQUIREMENTS MATRIX

The following tables are referenced below.

Table 3.2.1.1 - 1

Weapons System	Weapon Quantity	Weapon Weight	Notes:
Hellfire	14*	101 lbs. ea.	
Stinger	18*	22.6 lbs. ea.	
Rocket	62*	20.6 lbs. ea.	all 2.75 in rockets
20 mm ammo	500 rounds	112 lbs. total	PIE or HEI

* For a reconnaissance mission 4 Hellfire may be configured with 2 Stinger. When configuring a maximum missile load the weapon quantities are exclusive of each other.

Table 3.2.1.1 - 2

Configuration	Weight
Max self deployed	17,174 lbs.
Primary mission	10,112 lbs.
Empty	7500 lbs.
Useful load	2612 lbs.
Internal fuel	1820 lbs. (280 gals.)
Self deploy	7670 lbs. (1180 gals.)

REQ NO.	TITLE	REQUIREMENT
3.2.1.1.1.1	Terrain Data Base Definition	The MCC shall specify the terrain database (name and area) to be used by the RAH-66 Comanche simulator.
3.2.1.1.1.2	Simulator Identifier	The MCC shall specify the simulator vehicle identifier to be utilized by the RAH-66 Comanche simulator.
3.2.1.1.1.3	Simulator Placement	The MCC shall specify the location and heading (placement) to be utilized by the RAH-66 Comanche simulator.
3.2.1.1.1.4	Weapons Load	The MCC shall support the definition of the weapons load for the RAH-66 Comanche simulator.
3.2.1.1.1.5	Weapons Weight and Quantity	The MCC shall impose weight and quantity constraints in accordance with table 3.2.1.1.-1 given below
3.2.1.1.1.6	Default Weapons Load	The MCC shall maintain a default weapons load which to be used in the event that the weapons load is not explicitly selected.
3.2.1.1.1.7	Fueling	The MCC shall support the fueling of the RAH-66 Comanche simulator.
3.2.1.1.1.8	Fuel Load Constraint	The MCC shall impose a weight limit on the allowable fuel load in accordance with table 3.2.1.1.-2.

REQ NO.	TITLE	REQUIREMENT
3.2.1.1.1.9	Default Fuel Load Constraint	The MCC shall maintain a default fuel load which shall be used in the event that the fuel load is not explicitly selected.
3.2.1.1.1.10 See Notes (1)	RAH-66 Configuration	The MCC shall allow the configuration of one to eight RAH-66 Comanche simulators engaged in simulated reconnaissance, tactical maneuver, or battle exercises.
3.2.1.1.1.11 See Notes (2)	Configuration Parameters	The MCC shall specify the configuration parameters for the RAH-66 Comanche simulator to include but not be limited to the following:
3.2.1.1.2.1	Rearmament	The MCC shall rearm the RAH-66 Comanche simulator based on current weapons status and weapons load constraints contained in table 3.2.1.1-1.
3.2.1.1.2.2	Resupply Vehicles	The MCC shall use the same armament resupply vehicles for the RAH-66 rearmament as those used for already existing and selectable on the MCC.
3.2.1.1.2.3	Weapons Load Request	The RAH-66 Comanche simulator shall inform the MCC about the current status of weapons load upon request.
3.2.1.1.2.4	Rearm Time	The time of transfer of weapons shall be simulated by the MCC.
3.2.1.1.2.5	Refueling	The MCC shall refuel the RAH-66 Comanche simulator based on current fuel status and fuel load constraints contained in table 3.2.1.1-2.
3.2.1.1.2.6	Refueling Vehicles	The MCC shall use the same armament refueling vehicles for the RAH-66 refueling as those used for ground-based simulators.
3.2.1.1.2.7	Current Fuel Status	The RAH-66 Comanche simulator shall inform the MCC of the current status of fuel remaining in the vehicle upon request.
3.2.1.1.2.8	Fuel transfer Time	The time of transfer of fuel shall be simulated by the MCC.
3.2.1.1.2.10	Placement Upon Activation	Upon activation the simulator shall appear on the terrain database at the site of the 8 digit coordinates entered in the location entry on the SCC console.
3.2.1.1.2.11	Default Heading	The MCC shall default the heading to 0 degrees (Topographic North) should the heading entry be blank at the time of activation
3.2.1.1.3.1	Terminate Exercise	The MCC shall perform the termination of an exercise.
3.2.1.1.3.2	Termination Functions	The MCC shall perform the following during termination of an exercise: <ul style="list-style-type: none"> • Send Deactivation Requests to all simulators • Shutdown all Mac Consoles • Begin initialization state

REQ NO.	TITLE	REQUIREMENT
3.2.1.2.2.1.2	TOC Station Notification	The Computer Digital Message function shall notify the Tactical Operations Center (TOC) of an incoming message and place message contents in the TOC storage queue.
3.2.1.2.2.1.3	FSE Station Notification	The Computer Digital Message function shall notify the Fire Support Element (FSE) of an incoming message and place message contents in the FSE storage queue.
3.2.1.2.2.1.4	TOC Operator Notification of Message Receipt	The TOC station shall display an incoming message icon upon message notification from the MCC host.
3.2.1.2.2.1.5	FSE Operator Notification of Message Receipt	The FSE station shall display an incoming message icon upon message notification from the MCC host.
3.2.1.2.2.1.6	Message Storage	Messages will be automatically stored until either deleted by a station operator or until the maximum message storage limits have been attained.
3.2.1.2.2.1.6.1	Message Queuing	Messages shall be automatically queued upon receipt for either the FSE and/or the TOC.
3.2.1.2.2.1.6.2	Message Quantity	The MCC system shall store a maximum of 15 messages each for the FSE and TOC.
3.2.1.2.2.1.6.3	Most Recent Messages	Only the most recent messages each shall be stored for either the FSE or TOC stations.
3.2.1.2.2.1.6.4	Message Type	Message types received shall consist of either pre formatted text or free text messages.
3.2.1.2.2.2.1 See Note (1)	Pre Formatted Text Messages	The TOC or FSE shall be capable of sending pre formatted messages to the RAH-66 Comanche player(s). A pre formatted message is any previously defined message file.
3.2.1.2.2.2.2 See Note (1)	Free Text Messages	The TOC or FSE shall be capable of sending free text messages to the RAH-66 Comanche player(s). A free text message is any message entered by the station operator within the Access Mode.
3.2.1.2.2.2.3	Sending Messages	The TOC and FSE shall allow a message to be sent, deleted, retrieved for viewing, forwarded, acknowledged and replied to.
3.2.1.2.2.3.1.1	Retrieve Selected Message	The station operator shall be able to select any message for retrieval and display from the station's storage queue.
3.2.1.2.2.3.1.2 See Note (3)	Retrieve Function Transition	The operator shall be able to transition to Access Mode, Reply, Forward, Acknowledge and Delete from within the Retrieve function.
3.2.1.2.2.3.2.a	Message Reply Function	The reply function shall automatically send preformatted or freehand messages to the RWA player whose message has been selected.

REQ NO.	TITLE	REQUIREMENT
3.2.1.2.2.3.2.b	Message Reply Function	The operator shall be able to select Access Mode and the Delete function from within the Reply function.
3.2.1.2.2.3.2.1	Reply to Selected Message	The reply function allows the station operator to send a reply to the originator of the selected message from the storage queue.
3.2.1.2.2.3.2.2	Reply Function Message Type	The operator shall be able to reply to a selected message by either sending a freehand (typed) or a preformatted text message.
3.2.1.2.2.3.2.3	Reply Function Transition	The operator shall transition to Access Mode and the Delete function from within the Reply function.
3.2.1.2.2.3.3	Message Forward Function	The forward function shall allow the selected message to be forwarded to the RWA player or MCC Station. Preformatted or freehand messages can be included.
3.2.1.2.2.3.3.1	Forward Selected Message	The forward function allows the station operator to forward the selected message from the storage queue to another MCC station or RWA player.
3.2.1.2.2.3.3.2	Forward Function Message Type	The operator shall be able to forward the selected message and include either a freehand (typed) or a preformatted text message if desired.
3.2.1.2.2.3.3.3	Forward Function Transition	The operator shall transition to Access Mode and the Delete function from within the Forward function.
3.2.1.2.2.3.3.4	Select Access or Delete Function	The operator shall be able to select Access mode and the Delete function from within the Forward function.
3.2.1.2.2.3.4	Acknowledge Selected Message	Only one Acknowledgment shall be sent for any message in the storage queue.
3.2.1.2.2.3.4.1	Acknowledge Selected Message	The acknowledge function shall automatically acknowledge the selected message from the storage queue.
3.2.1.2.2.3.4.2	Acknowledge function message type	A preformatted text message will automatically be sent to the message originator acknowledging message receipt and display at the receiving station.
3.2.1.2.2.3.4.3	Acknowledge Function Transition	The acknowledge function shall automatically transition to the retrieve function and display the selected message unless the message has already been retrieved (displayed).
3.2.1.2.2.3.4.3.a See Note (3)	Acknowledge Function Transition	If the message has already been displayed, the operator shall transition to Access Mode, Retrieve or Delete functions.
3.2.1.2.2.3.5.1	Message Deletion	The station operator shall be able to delete messages from the station's storage queue.

REQ NO.	TITLE	REQUIREMENT
3.2.1.2.2.3.5.2	Delete Function Transition	The Delete function shall return automatically to Access Mode.
3.2.1.2.2.3.6	Send (originate) a Message	The send function shall allow the station operator to originate and send preformatted or freehand text messages to an RWA player or another MCC station.
3.2.1.2.2.3.6.1	Send Message	The send function allows the station operator to originate a message and send to another MCC station or to an RWA player.
3.2.1.2.2.3.6.2	Send Function Message Type	The operator shall be able to send either a freehand (typed) or a preformatted text message.
3.2.1.2.2.3.6.3	Send Function Transition	The operator shall be able to select Access Mode, Forward, or Delete function from within the Send function.
3.2.1.2.3	Segment capability relationships	Management Command and Control capability relationships are not affected by modifications except as described by the Digital Message/Communications capabilities.
3.2.1.2.4.	Segment External Interface Requirements.	All external interfaces shall remain SIMNET 6.6.1 compliant.
3.2.1.2.4.1	MCC Digital Message/Comm. Upgrades External Interface Description	The external interface for the MCC Digital Message/Communication Upgrade shall be compliant with SIMNET 6.6.1.

ATAC II Requirements

3.2.1	ATAS Symbology	The RWA software shall be modified to display an ATAS reticle model in the Out-the-Window (OTW) views when the ATAS missile is selected.
3.2.2.1	ATAS Symbology	The ATAS reticle shall consist solely of a square "lock-on" reticle.
3.2.2.2	ATAS Symbology	The ATAS reticle shall exhibit screen dimension ratios equivalent to that of the 2d overlay sensor version: horizontal extents occupying ~ 10% of the horizontal screen space, vertical extents occupying ~ 13% of the vertical screen space.
3.2.2.3	ATAS Symbology	The ATAS reticle shall be emulated as a 3d model in the Dynamic Elements Database (DED).
3.2.3	ATAS Symbology	The RWA software shall use the existing ATAS lock-on cone dimensions, i.e. +/- 10 degrees.
3.2.8	ATAS Symbology	The RWA software shall use the existing weapons switchology algorithms.

REQ NO.	TITLE	REQUIREMENT
3.2.9	ATAS Symbology	The 3d ATAS reticle shall be displayed on the OTW visuals only.
3.2.10.1	ATAS Symbology	The RWA DEDs shall be modified to contain a "normal" version of the ATAS reticle in the OTW DED for use in locking on to targets within a range of 3.5 km. or less.
3.2.10.2	ATAS Symbology	The RWA DEDs shall be modified to contain a "modified" version of the ATAS reticle in the OTW DED for use in locking on to targets beyond the OTW 3.5 km. visual range. (Note: The current design concept for the modified reticle is to have it contain a "black dot" in the center to signify that it is locked onto a target.)
3.2.10.3	ATAS Symbology	The RWA DEDs shall be modified to contain a "null" (invisible) version of the ATAS reticle in the Daylight Television (DTV) / Thermal DED (Note: The null version for the DTV/Thermal DED is required in order to avoid having the sensor inadvertently display the pilots 3d reticle model.)
3.2.11.1	ATAS Symbology	The 2d ATAS reticle to be displayed in the sensor channel shall consist of two dashed concentric squares centered on the sensor line of sight when the ATAS missile has been selected, but is not seeking. Neither the aural seek tone nor the aural lock-on tone will be generated.
3.2.11.2	ATAS Symbology	The 2d ATAS reticle to be displayed in the sensor channel shall consist of two dashed concentric squares centered on the sensor line of sight when the ATAS missile is actively seeking. The aural seek tone will be generated.
3.2.11.3	ATAS Symbology	The 2d ATAS reticle to be displayed in the sensor channel shall consist of two solid concentric squares centered on the target coordinates when the ATAS missile is tracking a target. The aural lock-on tone will be generated.
3.2.12	ATAS Symbology	The ATAS reticles (2d in the sensor channel and 3d in the OTW visual) shall be displayed when either the pilot or copilot/gunner (CPG) selects the ATAS missile.
3.3.1.5	Manned Rotary Wing Aircraft	A Missile Server shall not be required for autonomous Hellfire designation (as in the current implementation) functionality to exist. If no Missile Server is present, the Hellfire works as in the current implementation.

REQ NO.	TITLE	REQUIREMENT
3.3.1.10	Manned Rotary Wing Aircraft	The SAD menu shall be modified to allow a target UTM grid coordinate to be manually entered as the Hellfire destination point.
3.3.1.11	Manned Rotary Wing Aircraft	The RWA shall incorporate a random offset, forward of the target UTM grid coordinate, as the destination point which the Hellfire will fly toward.
3.3.1.13 See Note (4)	Manned Rotary Wing Aircraft	The Hellfire impact point shall be determined by the laser designation point, whether local (autonomous fire) or remote.
3.3.1.14	Manned Rotary Wing Aircraft	Automatic range determination shall be displayed as a four digit integer number on the sensor display, as in the current implementation.
3.3.1.15	Manned Rotary Wing Aircraft	Ranges calculated from target UTM grid coordinates shall be displayed in the format NXXXX where XXXX is the range to the coordinate in meters.
3.3.1.17	Manned Rotary Wing Aircraft	The modes of the Hellfire missiles (primary/secondary) and trajectories (LOBL, LOAL direct, LOAL high, LOAL low) shall be implemented only to the extent that they have been implemented in the current version of the RWA.
3.3.1.18	Manned Rotary Wing Aircraft	The laser rangefinder/designator symbology shall be displayed in the upper left corner of the sensor display.
3.3.1.19	Manned Rotary Wing Aircraft	The laser rangefinder mode symbology shall consist of the phrase "RNG".
3.3.1.21	Manned Rotary Wing Aircraft	The laser status symbology OFF/SAFE/ARM shall be displayed in the upper left corner of the sensor display, beneath the rangefinder/designator symbology.
3.3.1.25	Manned Rotary Wing Aircraft	The RWA Hellfire switchology shall remain as it is in the current implementation.
3.3.1.26.1	Manned Rotary Wing Aircraft	The RWA Hellfire constraint symbology shall consist of a solid "in constraint" square (as in the current implementation).
3.3.1.26.2	Manned Rotary Wing Aircraft	The RWA Hellfire constraint symbology shall consist of a dashed "out of constraint" square, the same size and shape as the "in constraint" version.
3.3.1.27	Manned Rotary Wing Aircraft	The RWA Hellfire constraint limits shall remain as they are in the current implementation, i.e., +/- 20 degrees.
3.3.1.30.2	Manned Rotary Wing Aircraft	The following shall be modifiable at any time the RWA is in an active state of simulation: Hellfire target UTM grid coordinates.

Notes:

- (1) This requirement is satisfied for a single RAH-66 Comanche player. The procedures verifying this requirement for multiple players may be found in Exercise "C".
- (2) This requirement is satisfied for all items listed, with the exception of Airframe Time. Refer to AIRNET Inspection/Analysis Report 3 for information related to satisfaction of the airframe portion of this requirement.
- (3) Access Mode is defined as the Message Queue display, and is equivalent to Retrieve.
- (4) This requirement is satisfied for local (autonomous) fire only. The procedures verifying this requirement for remote fire may be found in Exercise "C".

Exercise "A" Requirements Inspection/Analysis Matrix

REQ NO.	TITLE	REQUIREMENT	Report Reference
3.2.1.2.1.1	No Message Processing Required	The MCC Digital Message / Communications function shall operate in a standby state on the MCC system when message processing is not required.	1
3.2.1.2.1.2	Transition to Active State - Operator Request	The MCC Digital Message / Communications function shall transition to the active state upon receipt of an MCC operator request.	1
3.2.1.2.1.3	Transition to Active State - PDU Receipt	The MCC Digital Message / Communications function shall transition to the active state upon receipt of an digital message PDU by the MCC.	1
3.2.1.2.1.4	Transition to Standby State	The MCC Digital Message / Communications function shall transition to the standby state when there is no activity in any of the three active state modes - receive, send and access.	1
3.2.1.2.2.1.1	Activation Upon PDU Receipt	The Receive Mode shall be activated upon receipt of a digital message PDU by the MCC host.	1
3.9.1	MCC Comanche Support Upgrade Segment Qualification	The MCC Comanche Support Upgrade Segment shall be qualification tested at Ft. Rucker.	2
3.9.1.a	MCC Comanche Support Upgrade Segment Qualification	The MCC Comanche Support Upgrade test shall take place during the program integration and test phase (I&T).	2
3.9.1.b	MCC Comanche Support Upgrade Segment Qualification	The MCC Comanche Support Upgrade test shall not exceed 2 working days.	2
3.9.1.c	MCC Comanche Support Upgrade Segment Qualification	The testing shall demonstrate the MCC Comanche Support Upgrade provides the functionality described previously in this document.	2
3.9.2	MCC Digital Message / Communications Segment Qualification	The MCC Digital Message / Communications Segment shall be qualification tested at Ft. Rucker.	2

REQ NO.	TITLE	REQUIREMENT	Report Reference
3.9.2.a	MCC Digital Message / Communications Segment Qualification	The MCC Digital Message / Communications Segment test shall take place during the program integration and test phase (I&T).	2
3.9.2.b	MCC Digital Message / Communications Segment Qualification	The MCC Digital Message / Communications Segment test shall not exceed 1 working day.	2
3.9.2.c	MCC Digital Message / Communications Segment Qualification	The testing shall demonstrate the MCC Digital Message / Communications Segment provides the functionality described previously in this document.	2

ATAC II Requirements

3.1.1	General	Modifications to "RWA" functionality and capabilities shall be made solely to the manned vehicle Generic Rotary Wing Aircraft simulator unless stated otherwise.	4
3.1.2	General	ATAC software shall not be required to communicate via the DIS protocol.	4
3.1.3	General	Network communications shall be made using the current implementation of the SIMNET protocol.	4
3.1.4	General	Where necessary, extensions to the SIMNET protocol shall be allowed.	4
3.1.5	General	All software modifications will be made according to the guidelines and practices of the Kernighan and Ritchie "C" (K & R C) programming language.	4
3.2.4	ATAS Symbology	The RWA software shall use the existing ATAS lock-on algorithms for determining which types of entities it can lock on to.	5
3.2.5	ATAS Symbology	The RWA software shall use the existing ATAS intervisibility algorithms.	5
3.2.6	ATAS Symbology	The RWA software shall use the existing ATAS maximum lock-on range of 7.0 km.	5

REQ NO.	TITLE	REQUIREMENT	Report Reference
3.2.7	ATAS Symbology	The RWA software OTW maximum visual range of 3.5 km. shall remain as its is in the current software.	5
3.2.13	ATAS Symbology	The ATAS reticles shall be displayed for all missiles of type "target_guided" as defined in the RWA data file "reconfig.rwa".	5
3.2.14	ATAS Symbology	The ATAS reticles shall be displayed for any configuration of the RWA which has selected a "target_guided" missile type.	5
3.3.1.12	Manned Rotary Wing Aircraft	The Hellfire range (calculated from the target UTM grid coordinate or from the laser autorangefinder) shall determine the initial value for the Time of Flight (TOF) overlay on the sensor display.	6

Note: The Inspection/Analysis reports were submitted as an appendix to each respective test procedure document.

EXERCISE "B" REQUIREMENTS MATRIX

REQ NO.	TITLE	REQUIREMENT
3.2.1.3.1	Flight Model Initialization State.	The Flight Model Segment Initialization State shall be entered during the System Initialization process after system bootup. System state and status variables uniquely identify the RWA AirNet configuration and state.
3.2.1.3.1.1	Flight Controls Initialization.	Initialization of the Flight Controls Model Sub-Segment configuration shall be done during this state upon command from the system.
3.2.1.3.1.1.1	Flight Controls Data	Parameters to be set shall include maximum pitch, roll and yaw rates, turning radius, flight controls input sensitivity and profile, physical constants, conversion factors, integration constants, gains and limits.
3.2.1.3.1.1.1.1	Flight Controls Data File.	Data values shall be read from a flight controls model initialization file.
3.2.1.3.1.1.1.2	Flight Controls Data Format	The format of the data file shall allow modification of the data using a text editor.
3.2.1.3.1.2	Flight Dynamics Initialization.	Initialization of the Flight Dynamics Model Sub-Segment configuration shall be done during this state upon command from the system. During this mode, configuration flags and variables are set which point to specific submodules and data files for execution and loading.
3.2.1.3.1.2.1	Flight Dynamics Data	Initialization shall include downloading of coefficient tables for the main rotor, fuselage and stabilizers.
3.2.1.3.1.2.1.1	Flight Dynamics Data File.	These values shall be read from a flight dynamics model initialization file.
3.2.1.3.1.2.1.2	Flight Dynamics Data Format	The format of the data file shall allow modification of the data using a text editor.
3.2.1.3.1.3	Engine Initialization.	Initialization of the Engine Model Sub-Segment configuration shall be done during this state upon command from the system.
3.2.1.3.1.3.1	Engine Initialization	Initialization shall include downloading of data tables for the gas and power turbines, fuel consumption, power output, and acceleration coefficients.
3.2.1.3.1.3.1.1	Engine Data.	These values shall be read from an engine model initialization file.
3.2.1.3.1.3.1.2	Engine Data Format	The format of the data file shall allow modification of the data using a text editor.
3.2.1.3.2	Flight Model Run-Time State.	In this mode the Flight Model Segment shall be in stand-by awaiting RWA AirNet Flight model activity.

REQ NO.	TITLE	REQUIREMENT
3.2.1.3.2.1	Flight Model Idle Mode.	During the Flight Model Idle mode, the execution of the flight model functions shall be suspended.
3.2.1.3.2.1.2	Flight Model Idle Mode Change.	Execution shall be started or resumed from this mode.
3.2.1.3.2.1.4	Flight Model Idle Mode Functionality.	The modifications shall have no adverse affects upon the Flight Model Idle mode functionality.
3.2.1.3.2.2	Flight Model Execute Mode.	During the Flight Model Execution mode, the flight model shall be executed in real-time.
3.2.1.3.2.2.3	Flight Model Execute Mode Data Sources.	The source of coefficient data shall be table look ups.
3.2.1.3.2.2.4	Flight Model Execute Mode Functionality.	The modifications shall have no adverse affects upon the Flight Model Execute mode functionality.
3.2.1.3.2.2.5	Flight Controls Model	The Flight Controls Model Sub-Segment shall simulate the flight controls of the aircraft.
3.2.1.3.2.2.6	Flight Dynamics Model	The Flight Dynamics Model Sub-Segment shall provide a simulation of the flight characteristics of the aircraft.
3.2.1.3.2.2.6.b	Flight Dynamics Model	The simulation shall include portions of the flight envelope including cruise, ascent, descent, hover, and low-level flight with ground effect.
3.2.1.3.2.3.2	Flight Model Stop Mode Functionality.	The modifications shall have no adverse affects upon the Flight Model Stop mode functionality.
3.2.1.3.3	Segment Capability Relationships.	Flight Model Segment capability relationships shall not be affected by modifications and restructuring of the flight model functions.
3.2.1.3.3.a	Segment Capability Relationships.	The capability relationships shall remain intact.
3.2.1.3.4	Segment External Interface Requirements.	Flight Model Segment interface requirements shall not be affected by modifications and restructuring of the flight model functions.
3.2.1.3.4.a	Segment External Interface Requirements.	The interface requirements shall remain intact.
3.2.1.5	RWA Weapons Model Upgrade Segment	The intent of the RWA Weapons Model Upgrade is to improve the software by making it table driven.
3.2.1.5.1	Initialize Weapons State	The Initialize Weapons Segment state is entered during the System Initialization process after system bootup.
3.2.1.5.1.1.1	Guided Missile Trajectory Coefficient Data	Trajectory coefficient data associated with guided missiles shall be loaded at mission initialization.

REQ NO.	TITLE	REQUIREMENT
3.2.1.5.1.1.2	Guided Missile Trajectory Coefficient Data Format	Trajectory coefficient data files for Guided Missiles shall be in a format which allow modification through a standard text editor.
3.2.1.5.1.1.3	Ballistic Missiles Trajectory Coefficient Data	Trajectory coefficient data associated with ballistic missiles shall be loaded at mission initialization.
3.2.1.5.1.1.4	Ballistic Missile Trajectory Coefficient Data Format	Trajectory coefficient data files for Ballistic Missiles shall be in a format which allow modification through a standard text editor.
3.2.1.5.1.1.5	Ballistic Rounds Trajectory Coefficient Data	Trajectory coefficient data associated with Ballistic Rounds shall be loaded at mission initialization.
3.2.1.5.1.1.6	Ballistic Rounds Trajectory Coefficient Data Format	Trajectory coefficient data files for Ballistic Rounds shall be in a format which allow modification through a standard text editor.
3.2.1.5.1.2.1	Guided Missiles Characterization	Guided missile characteristics shall be initialized via data files.
3.2.1.5.1.2.2	Ballistic Missiles Characterization	Ballistic missile characteristics shall be initialized via data files.
3.2.1.5.1.2.3	Ballistic Rounds Characterization	Ballistic Rounds characteristics shall be initialized via data files.
3.2.1.5.2.4.1	Guided Missile Flyout	Guided Missile Flyout shall utilize new data structures containing trajectory and control data.
3.2.1.5.2.4.3	Ballistic Missile Flyout	Ballistic Missile Flyout shall utilize new data structures containing trajectory and control data.
3.2.1.5.2.4.4	Ballistic Round Flyout	Ballistic Round Flyout shall utilize new data structures containing trajectory and control data.

Exercise "B" Requirements Inspection/Analysis Matrix

REQ NO.	TITLE	REQUIREMENT	Report Reference
3.2.1.3.2.1.1	Flight Model Idle Mode Integration.	Integration computations shall be pzt in a stable state.	1
3.2.1.3.2.1.3	Flight Model Idle Mode Control.	This mode shall be controlled by the system executive.	1
3.2.1.3.2.2.1	Flight Model Execute Mode Execution.	Execution shall be stopped from this mode.	1
3.2.1.3.2.2.2	Flight Model Execute Mode Execution Rate.	The rate of execution shall be controlled by the system executive.	1
3.2.1.3.2.2.5.	Flight Controls Model	Input shall be used to calculate a resultant movement of a control surface and corresponding output to the flight dynamics model sub-segment.	2
3.2.1.3.2.2.6.	Flight Dynamics Model	The simulation shall include calculation of forces and moments, equations of motion, weight and balance, and aerodynamics.	3
3.2.1.3.2.2.7	Engine Model	The Engine Model Sub-Segment shall provide core engine representation, torque generation, engine fuel system utilization, and transmission representation.	4
3.2.1.3.2.3	Flight Model Stop Mode.	During the Flight Model Stop mode, the execution of the flight model functions shall be suspended.	1
3.2.1.3.2.3.1	Flight Model Stop Mode Control.	This mode shall be controlled by the system executive.	1
3.2.1.5.2.4.2	U Data Tables	Updates required Modification of the source code shall be limited to reference data tables containing data which is read in via data files.	5
3.9.3	RWA Flight Model Upgrade Segment Qualification	The RWA Flight Model Upgrade Segment shall be qualification tested at Ft. Rucker.	6
3.9.3.a	RWA Flight Model Upgrade Segment Qualification	The RWA Flight Model Upgrade Segment test shall take place during the program integration and test phase (I&T).	6

REQ NO.	TITLE	REQUIREMENT	Report Reference
3.9.3.b	RWA Flight Model Upgrade Segment Qualification	The RWA Flight Model Upgrade Segment test shall not exceed 2 working days.	6
3.9.3.c	RWA Flight Model Upgrade Segment Qualification	The testing shall demonstrate the RWA Flight Model Upgrade Segment provides the functionality described previously in this document.	6
3.9.5	RWA Weapons Model Upgrade Segment Qualification	The RWA Weapons Model Upgrade Segment shall be qualification tested at Ft. Rucker.	6
3.9.5.a	RWA Weapons Model Upgrade Segment Qualification	The RWA Weapons Model Upgrade Segment test shall take place during the program integration and test phase (I&T).	6
3.9.5.b	RWA Weapons Model Upgrade Segment Qualification	The RWA Weapons Model Upgrade Segment test shall not exceed 2 working days.	6
3.9.5.c	RWA Weapons Model Upgrade Segment Qualification	The testing shall demonstrate the RWA Weapons Model Upgrade Segment provides the functionality described previously in this document.	6

Note: The Inspection/Analysis reports were submitted as an appendix to each respective test procedure document.

EXERCISE "C" REQUIREMENTS MATRIX

REQ NO.	TITLE	REQUIREMENT
3.2.1.1.1.10	RAH-66 Configuration	The MCC shall allow the configuration of one to eight RAH-66 Comanche simulators engaged in simulated reconnaissance, tactical maneuver, or battle exercises.
3.2.1.1.1.12	Placement Conflict	The MCC shall place simulated vehicles in non-overlapping positions and reposition vehicles that are located in overlapping positions.
3.2.1.1.1.13	Minimum Placement Distance	The MCC shall resolve the placement such that the simulators are at least 33 meters apart.
3.2.1.1.2.9	Placement After Reconstitution	The MCC shall inform the RAH-66 Comanche simulator about its new location and heading (placement) during reconstitution of the vehicle.
3.2.1.2.2.2.1	PreFormatted Text Messages	The TOC or FSE shall be capable of sending preformatted messages to the RAH-66 Comanche player(s). A preformatted message is any previously defined message file.
3.2.1.2.2.2.2	Free Text Messages	The TOC or FSE shall be capable of sending free text messages to the RAH-66 Comanche player(s). A free text message is any message entered by the station operator within the Access Mode.
3.2.1.4	Improved Collective Mount	The delivered hardware shall insure that existing software is compatible.
3.2.1.4.1.5	Compatibility	The Improved Collective Mount shall be compatible with existing generic RWA software.
3.2.1.4.2	Segment Capability Relationships	Improved Collective Mount capability relationships are not affected by modifications and restructuring of the flight model functions. The capability relationships have remained intact.
3.2.1.4.3	Segment External Interface Requirements	Improved Collective Mount interface requirements are not affected by modifications and restructuring of the flight model functions.
3.2.1.6.1	Initialization State	The Kill COMM Initialization state places the communications system into a known state. The Initialization state has no modes.
3.2.1.6.1.1	COMM On Variable	The Kill COMM Initialization shall set the communications "COMM On" variable to enable ownship two-way communications.
3.2.1.6.2.1	Run Time COMM On Mode	The Run Time COMM On mode shall enable two-way communications between the ownship and other AirNet vehicles.

REQ NO.	TITLE	REQUIREMENT
3.2.1.6.2.2	Run Time COMM Off Mode	The Run Time COMM Off mode shall disable two-way communications between the ownship and other AirNet vehicles.
3.2.1.6.3.1	Over-ride_On Mode	The "over-ride_on" mode shall disable S/W control to the communications system and enable two-way communications.
3.2.1.6.3.2	Auto Mode	The "auto" mode shall enable S/W control of the communication system.
3.2.1.6.3.3	Over-ride_Off Mode	The "over-ride_off" mode shall disable S/W control of the communications system and disable communications to other AirNet devices.

ATAC II Requirements

3.3.1.8	Manned Rotary Wing Aircraft	The Situation Awareness Display (SAD) menu shall be modified to allow modification of eight Laser Codes A - H.
3.3.1.9	Manned Rotary Wing Aircraft	The SAD keypad shall allow the user to toggle through the valid laser codes plus the "normal" rangefinder mode for use by the laser range finder/designator.
3.3.1.13 See Note (1)	Manned Rotary Wing Aircraft	The Hellfire impact point shall be determined by the laser designation point, whether local (autonomous fire) or remote.
3.3.1.16.1	Manned Rotary Wing Aircraft	The SAD menu and keypad shall allow the user to select laser code A - H for use as the primary code by the Hellfire missile.
3.3.1.16.2	Manned Rotary Wing Aircraft	The SAD menu and keypad shall allow the user to select laser code A - H for use as the secondary code by the Hellfire missile.
3.3.1.16.3	Manned Rotary Wing Aircraft	The SAD menu and keypad shall allow the user to toggle between primary and secondary laser codes.
3.3.1.20	Manned Rotary Wing Aircraft	The laser designator mode symbology, consisting of the laser code A - H plus the four digit data field shall be displayed for 10 seconds, after which time only the laser code A - H will remain displayed.
3.3.1.22	Manned Rotary Wing Aircraft	The Hellfire laser code A - H shall be displayed near the bottom of the sensor display, in the same row and to the left of the TOF symbology.
3.3.1.30.1	Manned Rotary Wing Aircraft	The following shall be modifiable at any time the RWA is in an active state of simulation: Laser code data for laser codes A - H.
3.3.1.30.3	Manned Rotary Wing Aircraft	The following shall be modifiable at any time the RWA is in an active state of simulation: Laser code to be used by the Hellfire missile

3.3.1.30.4	Manned Rotary Wing Aircraft	The following shall be modifiable at any time the RWA is in an active state of simulation: Laser code or "normal" rangefinder mode to be used by the laser rangefinder/designator.
------------	-----------------------------	------------------------------------------------------------------------------------------------------------------------------------------------------------------------------------

Notes:

(1) This requirement is satisfied for remote fire only. The procedures verifying this requirement for local (autonomous fire) may be found in Exercise "A".

Exercise "C" Requirements Inspection/Analysis Matrix

REQ NO.	TITLE	REQUIREMENT	Report Reference
3.2.1.4.1.1	Smoother Operation	The collective shall rotate smoothly around its pivot axis for all values of angular velocity anticipated in normal operations for the entire 45° range of travel.	1
3.2.1.4.1.2	Friction Mechanism	The friction mechanism shall maintain its setting within 10% of initial pilot adjustment throughout the entire sortie (provided no readjustment is made).	1
3.2.1.4.1.3	Continuous Range Adjustment	The collective friction shall be continuously adjustable to provide a range of 12 to 420 in-lbs of resistive force in both directions of rotation throughout the entire range of travel.	1
3.2.1.4.1.4	Position Sensing Mechanism	The collective sensing mechanism shall increase the travel of the position sensing potentiometer by 30%.	1
3.9.4	Improved Collective Mount Segment Qualification	The Improved Collective Mount Segment shall be qualification tested at Ft. Rucker.	2
3.9.4.a	Improved Collective Mount Segment Qualification	The Improved Collective Mount Segment test shall take place during the program integration and test phase (I&T).	2
3.9.4.b	Improved Collective Mount Segment Qualification	The Improved Collective Mount Segment test shall not exceed 1 working day.	2
3.9.4.c	Improved Collective Mount Segment Qualification	The testing shall demonstrate the Improved Collective Mount Segment provides the functionality described previously in this document.	2
3.9.6	Kill Communications Upgrade Segment Qualification	The Kill Communications Upgrade Segment shall be qualification tested at Ft. Rucker.	2

REQ NO.	TITLE	REQUIREMENT	Report Reference
3.9.6.a	Kill Communications Upgrade Segment Qualification	The Kill Communications Upgrade Segment test shall take place during the program integration and test phase (I&T).	2
3.9.6.b	Kill Communications Upgrade Segment Qualification	The Kill Communications Upgrade Segment test shall not exceed 1 working 1 day.	2
3.9.6.c	Kill Communications Upgrade Segment Qualification	The testing shall demonstrate the Kill Communications Upgrade Segment provides the functionality described previously in this document.	2

ATAC II Requirements

3.3.1.1	Manned Rotary Wing Aircraft	The RWA shall be able to check for the existence of the Missile Server on the simulation network.	3
3.3.1.2	Manned Rotary Wing Aircraft	The RWA shall listen for an acknowledgement from the Missile Server.	3
3.3.1.3	Manned Rotary Wing Aircraft	The RWA shall be able to handoff simulation of the Hellfire missile to the Missile Server.	3
3.3.1.4	Manned Rotary Wing Aircraft	The RWA shall be able to cancel handoff of the Hellfire missile to the Missile Server.	3
3.3.1.6	Manned Rotary Wing Aircraft	A Missile Server must be present in order for remote Hellfire designation functionality to exist.	3
3.3.1.7	Manned Rotary Wing Aircraft	Laser Code Data shall be in the form of a four digit number with digits consisting solely of the numbers 1 thru 8.	4
3.3.1.23	Manned Rotary Wing Aircraft	When laser designating, the RWA shall transmit PDUs onto the simulation network describing the location being designated.	3
3.3.1.24	Manned Rotary Wing Aircraft	When laser designating has stopped, the RWA shall transmit a PDU onto the simulation network signifying this event.	3
3.3.1.28	Manned Rotary Wing Aircraft	The SAD shall allow laser code data for laser codes A - H to be saved to disk.	5

REQ NO.	TITLE	REQUIREMENT	Report Reference
3.3.1.29	Manned Rotary Wing Aircraft	The SAD shall allow laser code data for laser codes A - H to be retrieved from disk.	5

Note: The Inspection/Analysis reports were submitted as an appendix to each respective test procedure document.



APPENDIX B

ADST
SOFTWARE PROBLEM/CHANGE REPORTS
(SP/CR)

APPENDIX B

SP/CR Form		SP/CR NUMBER: 205	
PART I IDENTIFICATION		SITE: FL Rucker	
ORIGINATOR: J. Almanza - FTR 04		DATE: 8/16/93	
TITLE: AIRNET ATP: Masscomp SCC Does not recog 30mm Ammo Resupply			
PRIORITY Serious	PHASE Official release	AREA <input type="checkbox"/> HW <input checked="" type="checkbox"/> SW	
SCOPE Subsystem	DC/CONFIGURATION MCC - Masscomp	<input type="checkbox"/> FW <input type="checkbox"/> Doc	
Software:			
Hardware:			
PROBLEM DESCRIPTION:			
The ammo tables reflected on the MASSCOMP MAC (SCC) software does not contain any reference to the 30MM ammo type. Therefore, it cannot be selected for resupply.			
PROPOSED SOLUTION:			
Propose files on Masscomp MAC SCC be modified to include 30 MM weapons selection option.			
PART II RESOLUTION			
PROBLEM RESOLUTION:			
Appropriate files modified (corrected). Discrepancy resolved.			
PART III STATUS			
ASSIGNEE(S):		STATUS: Closed	
		DISPOSITION: In Baseline	
		METRIC CATEGORY:	
DUE DATE	OPEN APPROVAL	C.M. SIGNATURE	CLOSE APPROVAL
DATE: 9/30/93	NAME: DATE:	NAME: DATE:	NAME: DATE:

SP/CR Form		SP/CR NUMBER: 206	
PART I IDENTIFICATION SITE: Ft. Rucker			
ORIGINATOR: J. Almanza--FTR 06		DATE: 8/19/93	
TITLE: AIRNET ATP: Mescomp SW does not resupply 20MM or Hydra			
PRIORITY Serious	PHASE Official release	AREA <input type="checkbox"/> HW <input checked="" type="checkbox"/> SW	
SCOPE Subsystem	DO/CONFIGURATION MCC - Mescomp	<input type="checkbox"/> FW <input type="checkbox"/> Doc	
Software: Hardware:			
PROBLEM DESCRIPTION:			
Mescomp SW does not provide for loading (resupply) of the 20MM or the hydra weapons.			
PROPOSED SOLUTION:			
Problem occurs because of using the MPS to initialize the simulator. The Mescomp does not know about the initial conditions sent out by the MP's SCC. The Mescomp thinks the initialization value for the specific weapon type is "0". Therefore, it will not resupply.			
PART II RESOLUTION			
PROBLEM RESOLUTION:			
This discrepancy will be resolved as the newer subsystems--Session Managers--come on line with the DIS Architecture. No significant site operational impacts are evident. The problem is being resolved during operations by reconstituting the simulator. This has the effect of resupplying on-board resources. MCC deliverable documents have been updated to reflect the procedure to resupply via reconstitution.			
PART III STATUS			
ASSIGNEE(S):		STATUS: Closed	
		DISPOSITION: Leave As Is	
		METRIC CATEGORY:	
DUE DATE	OPEN APPROVAL	C.M. SIGNATURE	CLOSE APPROVAL
DATE: 9/30/93	NAME: DATE:	NAME: DATE:	NAME: DATE:

SP/CR Form		SP/CR NUMBER: 207	
PART I IDENTIFICATION	SITE: Ft. Rucker		
ORIGINATOR: J. Almaraz-FTR 06		DATE: 8/16/93	
TITLE: AIRNET ATP: MPS SCC Application size			
PRIORITY Minor	PHASE Official release	AREA <input type="checkbox"/> HWB	<input checked="" type="checkbox"/> SWB
SCOPE Subsystem	DO/CONFIGURATION MCC - Airnet	<input type="checkbox"/> FWB	<input type="checkbox"/> D-JC
Software:			
Hardware:			
PROBLEM DESCRIPTION:			
The MPS SCC Software no longer will fit on one floppy disc. The new airnet software application has increased in size and requires 2 floppy discs and therefore a second drive.			
PROPOSED SOLUTION:			
Investigate application size and reconcile the increase in size. Define/Examine alternatives.			
PART II RESOLUTION			
PROBLEM RESOLUTION:			
System is presently working with one floppy. Too many Macintosh operating system files were added to the floppy when it was initially set up. The extra files were removed and the application now fits on one floppy. The Software Maintenance Manual was updated to define creation of the floppy disc to define the correct file configuration.			
PART III STATUS			
ASSIGNEE(S):	STATUS: Closed		
	DISPOSITION: Documentation		
	METRIC CATEGORY:		
DUE DATE	OPEN APPROVAL	C.M. SIGNATURE	CLOSE APPROVAL
DATE: 9/30/93	NAME: DATE:	NAME: DATE:	NAME: DATE:

SP/CR Form		SP/CR NUMBER: 100	
PART I IDENTIFICATION SITE: Ft. Rucker			
ORIGINATOR: J. Almanza-FTR 07		DATE: 8/16/93	
TITLE: AIRNET ATP: Wyse Terminal Font			
PRIORITY Minor	PHASE Official release	AREA <input type="checkbox"/> HW <input checked="" type="checkbox"/> SW	
SCOPE Subsystem	DO/CONFIGURATION DMCC	<input type="checkbox"/> FW <input type="checkbox"/> Doc	
Software: Hardware:			
PROBLEM DESCRIPTION:			
X-Window server Font is different than the Host DMCC Terminal font.			
PROPOSED SOLUTION:			
Investigate if appropriate font file was purchased for the Wyse Terminal. (PMO has action)			
PART II RESOLUTION			
PROBLEM RESOLUTION:			
Font was changed to "adobe-times-r-normal--140--p-iso8859-1" on line 543 of dmcc/guitourc/afgen.c			
PART III STATUS			
ASSIGNEE(S):		STATUS: Closed DISPOSITION: In Baseline METRIC CATEGORY:	
DUE DATE DATE: 8/30/93	OPEN APPROVAL NAME: DATE:	C.M. SIGNATURE NAME: DATE:	CLOSE APPROVAL NAME: DATE:

SP/CR Form		SP/CR NUMBER: 209	
PART I IDENTIFICATION SITE: FL Rucker			
ORIGINATOR: J. Almanza-FTR OS		DATE: 8/16/93	
TITLE: AIRNET ATP: Masscomp MCC SW vehicle placement			
PRIORITY Minor	PHASE Official release	AREA <input type="checkbox"/> NEB	<input checked="" type="checkbox"/> SWB
SCOPE Subsystem	DO/CONFIGURATION MCC - Masscomp	<input type="checkbox"/> FIB	<input type="checkbox"/> Boc
Software:			
Hardware:			
PROBLEM DESCRIPTION:			
Ainet Requirement 3.2.1.1.1.13 states a minimum vehicle placement separation of 33 meters on initialization. The current separation is 20 meters apart.			
PROPOSED SOLUTION:			
Review requirement-determine correct separation distance (20 meters or 33 meters). Note: the Ainet test plan/procedure states 33 m.			
PART II RESOLUTION			
PROBLEM RESOLUTION:			
The current separation of 20 meters is acceptable to the operational users. The 33 meter requirement was inadvertently used from a requirements document which was developed outside of this Delivery Order. The Ainet Functional Spec was used as a guide only. Since the 20 meter separation is , and has been, the placement separation it is acceptable to the operational users.			
PART III STATUS			
ASSIGNEE(S):		STATUS: Closed	
		DISPOSITION: Leave As Is	
		METRIC CATEGORY:	
DUE DATE	OPEN APPROVAL	C.M. SIGNATURE	CLOSE APPROVAL
DATE: 9/30/93	NAME: DATE:	NAME: DATE:	NAME: DATE:

SP/CR Form		SP/CR NUMBER: 210	
PART I IDENTIFICATION		SITE: Ft. Rucker	
ORIGINATOR: J. Almanza-FTR 11		DATE: 8/16/93	
TITLE: AIFNET ATP: FWA:Screen Freezes when fire Hydra			
PRIORITY Serious		PHASE Official release	
SCOPE Subsystem		DO/CONFIGURATION FWA - GT111	
AREA <input type="checkbox"/> NEW <input checked="" type="checkbox"/> SW		AREA <input type="checkbox"/> FW <input type="checkbox"/> Doc	
Software:			
Hardware:			
PROBLEM DESCRIPTION:			
<p>When firing the HYDRA MP3M Ammo type, the screen does not reflect the "in-air" dispersion of the bombs. The screen also hesitates and freezes for a split second. The screen does reflect the bombs exploding on the ground.</p>			
PROPOSED SOLUTION:			
More investigation required.			
PART II RESOLUTION			
PROBLEM RESOLUTION:			
<p>Cause of problem was in sub_m73.c file. This is read every time a Hydra rocket is fired. The routine to read a data file for the MP3M munition was in this file, consequently the file read operation conflicted with the real-time operation of the CIG. Moved the routine to read the data file out of sub_m73.c to rwa_hydra.c along with the other data file reads. This causes the data file to be read once on initialization of the simulation.</p>			
PART III STATUS			
ASSIGNEE(S):		STATUS: Closed	
		DISPOSITION: In Baseline	
		METRIC CATEGORY:	
DUE DATE		OPEN APPROVAL	
DATE: 8/30/93		NAME:	
		DATE:	
		C.M. SIGNATURE	
		NAME:	
		DATE:	
		CLOSE APPROVAL	
		NAME:	
		DATE:	

SP/CR Form		SP/CR NUMBER:	211
PART I IDENTIFICATION		SITE: Ft. Rucker	
ORIGINATOR: J. Almanza-FTR 00		DATE: 8/16/93	
TITLE: AIRNET ATP: SW not tested on all units			
PRIORITY Minor	PHASE Official release	AREA <input type="checkbox"/> HRD	<input checked="" type="checkbox"/> SW
SCOPE Subsystem	DO/CONFIGURATION RWA - GT111	<input type="checkbox"/> FW	<input type="checkbox"/> Doc
Software: RWA Alm			
Hardware:			
PROBLEM DESCRIPTION:			
The following units were not available during the on-site test phase for verification of the new RWA SW load. GT111 units B9002 and B9003.			
PROPOSED SOLUTION:			
Load new software when units are made available to FT Rucker--this is TBD.			
PART II RESOLUTION			
PROBLEM RESOLUTION:			
Fully installed on these two units and tested. This discrepancy has been completed by Ft. Rucker Personnel.			
PART III STATUS			
ASSIGNEE(S):	STATUS: Closed DISPOSITION: None METRIC CATEGORY:		
DUE DATE DATE: 12/30/93	OPEN APPROVAL NAME: DATE:	C.M. SIGNATURE NAME: DATE:	CLOSE APPROVAL NAME: DATE:

SP/CR Form		SP/CR NUMBER: 212	
PART I IDENTIFICATION	SITE: Ft. Rucker		
ORIGINATOR: J. Almanza-FTR 02	DATE: 8/16/93		
TITLE: AIRNET ATP: Wyse Terminal Inop			
PRIORITY Minor	PHASE Official release	AREA <input checked="" type="checkbox"/> HW <input type="checkbox"/> SW	
SCOPE Unit	DO/CONFIGURATION DACC	<input type="checkbox"/> FW <input type="checkbox"/> Doc	
Software:			
Hardware:			
PROBLEM DESCRIPTION:			
<ul style="list-style-type: none"> • Wyse Terminal (s/n OGP11A00167) would not power up correctly. Only makes attempt, screen remains dark. • No power cords were delivered with Wyse terminals. • One missing keyboard cord. 			
PROPOSED SOLUTION:			
LOCAL PMO action.			
PART II RESOLUTION			
PROBLEM RESOLUTION:			
Terminal was sent out for repair. Repairs have been completed; terminal has been returned to Ft Rucker and was tested and accepted. Power cords were provided and missing keyboard cord replaced.			
PART III STATUS			
ASSIGNEE(S):	STATUS: Closed		
	DISPOSITION: None		
	METRIC CATEGORY:		
DUE DATE	OPEN APPROVAL	C.M. SIGNATURE	CLOSE APPROVAL
DATE: 9/30/93	NAME: DATE:	NAME: DATE:	NAME: DATE:

January 20, 1994

SP/CR Form		SP/CR NUMBER:	213
PART I	IDENTIFICATION	SITE: Ft. Rucker	
ORIGINATOR: J. Almanza-FTR 10		DATE: 8/18/93	
TITLE: AIRNET ATP: KII Comm Relay SW Inop			
PRIORITY Minor	PHASE Official release	AREA <input checked="" type="checkbox"/> HW <input type="checkbox"/> SW	
SCOPE Unit	DO/CONFIGURATION RWA	<input type="checkbox"/> FW <input type="checkbox"/> Doc	
Software:			
Hardware:			
PROBLEM DESCRIPTION:			
The KII Comm Relay Switch has not been installed in the following units: 81, 84, 85, 86, 88			
PROPOSED SOLUTION:			
Install KII Comm Hardware in remaining units.			
PART II RESOLUTION			
PROBLEM RESOLUTION:			
Ft Rucker personnel installed the hardware in the remaining units- complete week ending 21 Aug 93.			
PART III STATUS			
ASSIGNEE(S):		STATUS: Closed	
		DISPOSITION: None	
		METRIC CATEGORY:	
DUE DATE	OPEN APPROVAL	C.M. SIGNATURE	CLOSE APPROVAL
DATE: 8/31/93	NAME: DATE:	NAME: DATE:	NAME: DATE:

SP/CR Form		SP/CR NUMBER: 214	
PART I IDENTIFICATION		SITE: Ft. Rucker	
ORIGINATOR: J. Almanza-FTR-1		DATE: 8/16/93	
TITLE: AIRNET ATP: Collective Mount			
PRIORITY Minor	PHASE Official release	AREA <input checked="" type="checkbox"/> HW	<input type="checkbox"/> SW
SCOPE Unit	DO/CONFIGURATION FWA	<input type="checkbox"/> FW	<input type="checkbox"/> Doc
Software:			
Hardware:			
PROBLEM DESCRIPTION:			
When pulling up on the collective mount, the distances are inconsistent from unit to unit.			
PROPOSED SOLUTION:			
Install original "pots" on collective mount mechanism. Has already been accomplished on units 81 and 83			
PART II RESOLUTION			
PROBLEM RESOLUTION:			
Replaced new "pots" in collective mount mechanism with the original "pots". Completed 21 Aug 93.			
PART III STATUS			
ASSIGNEE(S):		STATUS: Closed	
		DISPOSITION: In Baseline	
		METRIC CATEGORY:	
DUE DATE	OPEN APPROVAL	C.M. SIGNATURE	CLOSE APPROVAL
DATE: 8/31/93	NAME: DATE:	NAME: DATE:	NAME: DATE:

SP/CR Form		SP/CR NUMBER: 215	
PART I IDENTIFICATION		SITE: Ft. Rucker	
ORIGINATOR: J. Almanza-FTR-3		DATE: 8/12/93	
TITLE: AIRNET ATP: DMCC X-Window application crashes.			
PRIORITY Minor	PHASE Official release	AREA <input type="checkbox"/> HW <input checked="" type="checkbox"/> SW	
SCOPE Subsystem	DO/CONFIGURATION DMCC	<input type="checkbox"/> FW <input type="checkbox"/> Doc	
Software:			
Hardware:			
PROBLEM DESCRIPTION:			
<p>The DMCC X-Window application crashes with a segmentation fault in routine X Widget to Application Context ().</p> <p>This occurs randomly—not consistent.</p>			
PROPOSED SOLUTION:			
<p>This problem is not re-creatable. Recovery process is to reboot the DMCC Host and / or terminal where the termination occurred.</p> <p>Message in queue are lost.</p> <p>Suspect this might be due to network loading. Recommend the DMCC X-Terms be on a separate ethernet. to thompson.</p>			
PART II RESOLUTION			
PROBLEM RESOLUTION:			
Problem could not be duplicated.			
PART III STATUS			
ASSIGNEE(S):		STATUS: Closed	
		DISPOSITION: Not Reproducible / Can't Fix	
		METRIC CATEGORY:	
DUE DATE	OPEN APPROVAL	C.M. SIGNATURE	CLOSE APPROVAL
DATE: 9/30/93	NAME: DATE:	NAME: DATE:	NAME: DATE:

APPENDIX C

**FINAL
ADST/AIRNET RWA
TEST PROCEDURES
("AS RUN")**

APPENDIX C

APPENDIX C: TABLE OF CONTENTS

EXERCISE A - Test Cases 1 and 2..... CA-1
EXERCISE B - Test Cases 3 and 5..... CB-1
EXERCISE C - Test Cases 4 and 6..... CC-1

ADST/WDL/TR--93-003274

January 20, 1994

THIS PAGE INTENTIONALLY LEFT BLANK



3200 Zanker Rd.
P.O. Box 49041
San Jose, CA 95161-9041

DOC CODE ADST/WDL/TR-92-003029

Procedure No. **EXERCISE "A"**
TEST CASES 1&2

Page 1 of 101

CDRL NO. A009

TABLE OF CONTENTS PAGE NO.

REVISION HISTORY	2
1.0 SCOPE	3
2.0 APPLICABLE DOCUMENTS	3
3.0 TEST ENVIRONMENT REQUIREMENTS	3
4.0 TEST PREPARATION	4
5.0 TEST PROCEDURE	8
6.0 NOTES	78
7.0 TEST FAILURES/INTERRUPTIONS	79
8.0 GLOSSARY	80
APPENDIX A	82
APPENDIX B	89
APPENDIX C	92

Test Start Time/Date		Test Complete Time/Date	
Prepared Under		Program	ADST/AIRNET RWA
Contract Number	N61339-91-D0001	Equipment Serial Number	N/A
Test Engineer	Date	Test Performed By	Date
		<i>[Signature]</i>	8-18-93
Program Engineer	Date	Test Witnessed By	Date
<i>[Signature]</i>	8-15-93	<i>[Signature]</i>	8-18-93
Quality Assurance	Date	Customer Rep	
		Data Reviewed By	Date
Program Office	Date	<i>[Signature]</i>	
		Customer Rep	
Release Date			

LORAL
Micro Development Labs

3200 Zanker Rd.
P.O. Box 49041
San Jose, CA 95161-9041

Procedure No. EXERCISE 'A'
TEST CASES 1&2

Page 2 of 101

CDRL NO. A009

REVISION HISTORY

All revised or amended pages are listed below. Upon receipt, substitute pages of an amendment shall be inserted in the basic document after removal of the superseded pages. Revisions of test procedures shall be used as released.

REVISION	DATE	CHANGED BY	TYPE OF CHANGE OR REASON	PAGES AFFECTED

WDL 2679C

92321m.3a

11-92

[CA-2]

LORAL

3200 Zanker Rd.
P.O. Box 49041
San Jose, CA 95161-9041

Procedure No. **EXERCISE "A"**
TEST CASES 1 & 2

CDRL NO. A009

1.0 SCOPE

This document establishes the test procedure for demonstrating the capabilities as described by the requirements listed in Section 5.0 of this document. This test procedure provides for demonstrating Test Cases No. 1 & 2 as described in the AIRNET RWA Acceptance Test Plan and missile firing capabilities of the ATAC II RWA. Test cases 1 & 2 were combined to be efficiently demonstrated in one exercise, Exercise "A", as performed during this test.

2.0 APPLICABLE DOCUMENTS

The following documents of the issue shown form a part of the test procedure to the extent specified herein.

- a. Recommended Spares and Support Equipment, DI-V-30801
- b. MCC Operator's Manual, DI-MISC-80711
- c. AIRNET Data Handbook, March 14, 1986.
- d. System Specification for the Rotary Wing Aircraft AIRNET Aeromodel and Weapons Model Conversion, dated 6 June 1992.
- e. Statement of Work for the Acquisition of Rotary Wing Aircraft AIRNET Upgrades, dated 30 March 1992.
- f. AIRNET RWA Acceptance Test Plan, dated 1 Nov. 1992.
- g. DI-DRPR-81002, Developmental Design Drawings and Associated Lists.
- h. RWA System Integration Plan, August 5, 1992.
- i. Software Requirements Specification for Air to Air Combat (ATAC) II Airnet Experiment, Revision 2.0, 4/10/92

3.0 TEST ENVIRONMENT REQUIREMENTS

3.1 Test Conditions - Unless otherwise directed, tests shall be performed under ambient laboratory conditions of pressure, temperature, and humidity provided that the temperature is within the range of plus 10 to 40 degrees Celsius.

3.2 Test Witnessing - Test witnessing shall be provided by a representative of the LORAL WDL Quality Assurance and a designated representative of the receiving organization.

3.3 Measurements - Performance measurements are not applicable to this system level test but observations for validation of expected results will be recorded as specified in the test procedure.

3.4 Tolerance - Tolerance measurements are not applicable to this system level test. The tolerances used in the procedures are guidelines and not related to satisfying specific tolerance requirements.

4.0 TEST PREPARATION

4.1 Test Configuration - The following diagram reflects the hardware configuration required for this test. This test configuration is based on the San Jose System Development Facility (SDF) and may require modification when the test is executed at the Ft. Rucker facility. The basic components reflected in this block diagram are required at either facility in support of the execution of this test.

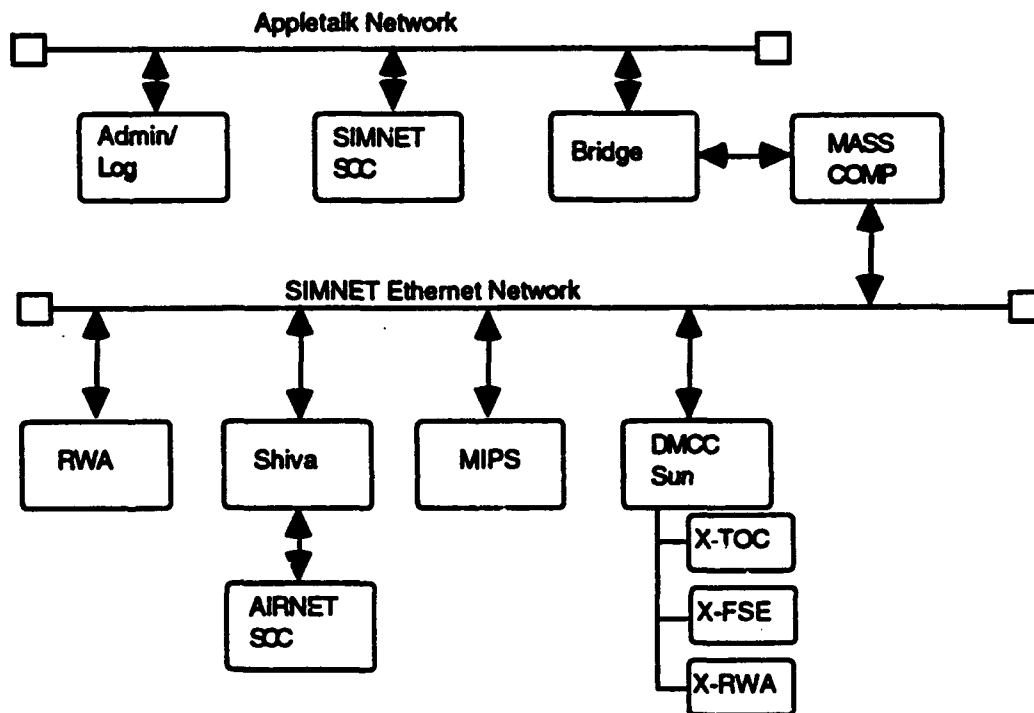

Figure 4.1 - 1 Required System Components

The software configuration required for this test is as follows:

Software	Version
• SIMNET Mescomp MCC	2.0.0
• SIMNET Mac SCC	2.0.0
• SIMNET Mac Admin/Log	2.0.0
• AIRNET MIPS MCC Phantom	2.0.0
• AIRNET Mac SCC	1.0.0
• GT Operating System	GT 4.7 Apr. 9 13:35:35 PDT 1991
• GT Real Time Software	rttgr5.7
• Rotary Wing Aircraft (RWA)	1.1.0
• Digital Message Communications Console	1.6.2

4.2 System Setup

The system set up procedures for this test are shown in Tables 4.2 - 1 through 4.

Table 4.2 - 1 Rotary Wing Aircraft Simulator Set Up

Action	(√)
Boot the RWA GT-111 Simulator	()
Verify the GT Operating System as GT 4.7	()
Download the RWA executable and data files	()
Calibrate the RWA simulator	()
Verify that the collective mount is in its most downward position	()
Verify that the weapons arming switches are in the armed position	()
Initiate the real-time simulation software	()
Initiate the RWA executable with parameter file Knox.par, keyboard control, exercise number 1, and no missile server	()

Table 4.2 - 2 AIRNET Management, Command and Control Console Set Up

Action	(√)
Download the MIPS Phantom process and data files	()
Load the Mac System Control Console software	()
Initiate the network process	()
Initiate the MIPS Phantom process using the Fort Knox Data Base	()
Initiate the AIRNET MCC System Control Console Software	()
Set up the AIRNET MCC to utilize the network	()

Table 4.2 - 3 SIMNET Management, Command and Control Console Set Up

Action	(√)
Load the Mac System Control Console software	()
Load the Mac Admin./Log Console software	()
Initiate the SIMNET MCC System Control Console Software	()
Initiate the SIMNET MCC Administration/Logistics Software	()
Initiate the MASSCOMP MCC process	()

Table 4.2 - 4 Digital Message Console Set Up

Action	(√)
Initiate the DMCC software	()
Initiate a user interface for the TOC, FSE and RAH-66	()
Log into a console as the TOC, exercise number 1	()
Log onto the network, and set up addressees of FSE and RAH-66, a CEOI List of TOC and RAHTOC, and locations of ES960645 and ES967650	()
Log into a console as the FSE, exercise number 1	()
Log onto the network, and set up addressees of TOC, RAH-66 and RAHTOC, a CEOI List of FSE, and a location of ES979700	()
Log into a console as the RAH-66, exercise number 1	()
Log onto the network, and set up addressees of TOC and FSE, a CEOI List of RAH-66 and RAHTOC	()

4.3 Test Requirements

The technical capabilities and skills required for this test are as follows:

- The optimum number of personnel for the conduct of this test is three (3); however it is possible to conduct this test with a single individual.
- The tester(s) are familiar with the operation of the RWA, including its Pilot and Co-Pilot/ Gunner positions.
- The tester(s) are familiar with the operation of the AIRNET (MIPS-based) MCC.
- The tester(s) are familiar with the operation of the SIMNET (Masscomp-based) MCC.
- The tester(s) are familiar with the operation of the DMCC.

5.0 TEST PROCEDURE

Appendix A of this document, Exercise "A" Requirements Matrix, identifies the requirements to be validated during the execution of the test procedure as provided in this section. This step-by-step procedure provides for an indication on the success or failure of each step as it is executed.

5.1 Test Description - The basis for this test procedure is a simple exercise scenario and its set up. This scenario incorporates an RAH-66 Comanche into the existing AIRNET capabilities. A top level description of the exercise follows.

The RAH-66 takes off from a point to the rear of the Battalion Headquarters, flying to a point North where refueling takes place. The aircraft takes off again heading towards a target area designated by the FSE who has fired on the target and requested RAH-66 support. The RAH-66 fires on the target, then returns to an area near Battalion Headquarters for rearming. Digital messages are transmitted/received throughout the scenario.

5.2 Test Procedures - The test procedures which follow demonstrate requirement satisfaction while verifying the use of an RAH-66 Comanche within the existing AIRNET system.

After each step is performed, mark the status of the action as:

- S - Satisfactory with no anomaly.
- SA - Satisfactory with an anomaly indicated and documented.
- U - Unsatisfactory with an anomaly indicated and documented.

Notes:

- (1) Requirements shown in standard face type are partially satisfied at the point within the test that they are referenced.
- (2) Requirements shown in bold face type are wholly satisfied at the point within the test that they are referenced.
- (3) References to 8B FRED are to a specific simulator located at the Loral WDL SDF. Should this test be run elsewhere, 8B FRED references should be replaced with any like device available at that facility.
- (4) References to a Battlemaster password of "foozball" are specific to the Loral WDL SDF. Should this test be run elsewhere, the correct Battlemaster password must be used.
- (5) This procedure does not attempt to follow standard Army operating procedures.
- (6) This exercise is assumed to be exercise 1.

5.2.1 Set Up Exercise at AIRNET System Control Console - The steps in this subparagraph consist of instructions for initializing the exercise number, the role of the Management, Command and Control Console, and the exercise's geographic area.

<u>Step</u>	<u>Operator/System Action</u>	<u>Expected Result</u>	<u>Status</u> (Check One)
10	At the Airnet SCC, start the exercise initialization process by clicking on the START button.	A display appears showing the exercise number, the MCC role, and the terrain to be used in the exercise.	<input checked="" type="checkbox"/> S <input type="checkbox"/> SA <input type="checkbox"/> U
20	Verify that the MCC is participating in Exercise 1.	The MCC is participating in Exercise 1.	<input checked="" type="checkbox"/> S <input type="checkbox"/> SA <input type="checkbox"/> U
30	Select the default role of the MCC to be US.	The display shows the default MCC role to be US.	<input checked="" type="checkbox"/> S <input type="checkbox"/> SA <input type="checkbox"/> U
40	Verify that the terrain to be used for the exercise is Fort Knox 8/14/90, SW corner: ES450550, NE corner: FT200050 Go to the NEXT menu.	An Overview menu is displayed showing the following selectable options: Simulator Allocation Simulator Activation Command Post Initialization Service Element Initialization Battlemaster •3.2.1.1.1.1	<input checked="" type="checkbox"/> S <input type="checkbox"/> SA <input type="checkbox"/> U

5.2.2 Set Up the RWA Simulator as an RAH-66 Comanche - The steps in this subparagraph consist of instructions for initializing a Fully Reconfigurable Device (FRED) as an RAH-66 Comanche.

<u>Step</u>	<u>Operator/System Action</u>	<u>Expected Result</u>	<u>Status</u> (Check One)
50	Select the Simulator Allocation Option and GO to the next menu.	A display appears showing the simulators available for allocation, including one or more FRED simulators. •3.2.1.1.1.2	<input checked="" type="checkbox"/> S <input type="checkbox"/> SA <input type="checkbox"/> U
60	Highlight a FRED (SDF - 8B Fred) entry and click on the ALLOCATE button.	A display appears allowing element assignment.	<input checked="" type="checkbox"/> S <input type="checkbox"/> SA <input type="checkbox"/> U
70	Assign the entity to A Company by double clicking on US Army, then 223rd Attack Helo Battalion, then A Company.	The display shows the entity to be assigned to A Company.	<input checked="" type="checkbox"/> S <input type="checkbox"/> SA <input type="checkbox"/> U

- | | | |
|------------------------------------------------------------------------------------------------------------------------------------------------------------------|-----------------------------------------------------------------------------------------------------------------------------------------------------------------------------------------------------------------------------------------------------------------------------------------------------------------------------------------------------------------------------------------------|----------------------------------------------------------------------------------------------|
| 80 Click on the ASSIGN button. | A display appears showing the simulators available for activation, including 8B FRED which is now shown as assigned to A Company, but not yet placed. | <input checked="" type="checkbox"/> S <input type="checkbox"/> SA <input type="checkbox"/> U |
| 90 Click on the Overview button. | The Overview menu is displayed. | <input checked="" type="checkbox"/> S <input type="checkbox"/> SA <input type="checkbox"/> U |
| 100 Select the Simulator Activation Option and GO to the next menu. | A display appears allowing simulator activation. | <input type="checkbox"/> S <input type="checkbox"/> SA <input type="checkbox"/> U |
| 110 Activate the simulator in A Company by double clicking on US Army, then 223rd Attack Helo Battalion, then A Company. | The display shows the simulator to be activated in A Company. | <input checked="" type="checkbox"/> S <input type="checkbox"/> SA <input type="checkbox"/> U |
| 120 Set a default location of ES950550 and verify that the default force is US. Go to the NEXT menu. | A display appears showing the activated simulators (8B FRED assigned to A Company, not placed)
•3.2.1.1.1.3 (!ocation) | <input checked="" type="checkbox"/> S <input type="checkbox"/> SA <input type="checkbox"/> U |
| 130 Highlight the 8B FRED entry by clicking on the entry and go to the NEXT menu. | A display appears allowing simulator customization. | <input checked="" type="checkbox"/> S <input type="checkbox"/> SA <input type="checkbox"/> U |
| 140 Customize 8B FRED with a tail number of 3, a location of ES95026002, an alignment of US, a maintenance status of New, and a vehicle type of RAH-66 Comanche. | The display reflects the custom selections. Note that the display allows specification of a heading.
•3.2.1.1.1.3
•3.2.1.1.1.11 (tail #, maint. status)
•3.2.1.1.2.11 (def. heading) | <input checked="" type="checkbox"/> S <input type="checkbox"/> SA <input type="checkbox"/> U |
| 150 Verify that the default weapons load is:
4 Hellfire Missiles
2 Stingers
0 Hydra 70 M151 (10 lb.)
320 Rounds 20 mm HEI
0 Round 20 mm PIE | The display reflects the default weapons load. The weapons load is within the quantity and weight requirements as noted below:
4 Hellfires @ 101 lbs. ea.
2 Stingers @ 22.6 lbs. ea.
320 Rounds HEI @ 0.22+ lbs. ea.
Fuel @ 1690 lbs.
2 man crew @ 200 lbs. ea.
Aircraft @ 7500 lbs.
=====
Total Weight: 10,110.88 lbs.
•3.2.1.1.1.5 (weapons wt.)
•3.2.1.1.1.6 | <input checked="" type="checkbox"/> S <input type="checkbox"/> SA <input type="checkbox"/> U |

- | | | |
|-------------------------------------------------------------------------------|-----------------------------------------------------------------------------------------------------------------------------------------------------------------|----------------------------------------------------------------------------------------------|
| 160 Verify that the default fuel load is: 1690 lbs. (260 gals.) | The display reflects the default fuel load. The fuel load is within the weight constraints of 1820 lbs. (280 gals.).
•3.2.1.1.1.8 (fuel wt.)
•3.2.1.1.1.9 | <input checked="" type="checkbox"/> S <input type="checkbox"/> SA <input type="checkbox"/> U |
| 170 Select the fuel entry and specify a fuel load of 1900 lbs. | The display reflects a fuel entry of 1900 lbs. | <input checked="" type="checkbox"/> S <input type="checkbox"/> SA <input type="checkbox"/> U |
| 180 Select the Hellfire missiles entry and specify a weapons load of 16. | The display reflects a Hellfire entry of 16. | <input checked="" type="checkbox"/> S <input type="checkbox"/> SA <input type="checkbox"/> U |
| 190 Select the Stinger entry and specify a weapons load of 22. | The display reflects a Stinger entry of 22. | <input checked="" type="checkbox"/> S <input type="checkbox"/> SA <input type="checkbox"/> U |
| 200 Select the Hydra 70 M151 (10 lb.) entry and specify a weapons load of 78. | The display reflects a Hydra entry of 78. | <input checked="" type="checkbox"/> S <input type="checkbox"/> SA <input type="checkbox"/> U |
| 210 Select the 20 mm HEI entry and specify a weapons load of 600 rounds. | The display reflects a HEI entry of 600 rounds. | <input checked="" type="checkbox"/> S <input type="checkbox"/> SA <input type="checkbox"/> U |
| 220 Select the ACTIVATE button. | The system displays a message indicating that an invalid fuel level value has been entered.
•3.2.1.1.1.8 | <input checked="" type="checkbox"/> S <input type="checkbox"/> SA <input type="checkbox"/> U |
| 230 Click on the OK button. | The display returns to the vehicle customization display. | <input checked="" type="checkbox"/> S <input type="checkbox"/> SA <input type="checkbox"/> U |
| 240 Select the fuel entry and specify a fuel load of 1600 lbs. | The display reflects the custom fuel selection.
•3.2.1.1.1.7
•3.2.1.1.1.11 (fuel) | <input checked="" type="checkbox"/> S <input type="checkbox"/> SA <input type="checkbox"/> U |
| 250 Select the ACTIVATE button. | The system displays a message indicating that an invalid number of 20 mm HEI rounds has been entered.
•3.2.1.1.1.5 | <input checked="" type="checkbox"/> S <input type="checkbox"/> SA <input type="checkbox"/> U |
| 260 Click on the OK button. | The display returns to the vehicle customization display. | <input checked="" type="checkbox"/> S <input type="checkbox"/> SA <input type="checkbox"/> U |
| 270 Select the 20 mm HEI entry and specify a weapons load of 360 rounds. | The display reflects the custom 20 mm HEI selection.
•3.2.1.1.1.4
•3.2.1.1.1.11 (guns) | <input checked="" type="checkbox"/> S <input type="checkbox"/> SA <input type="checkbox"/> U |

- | | | |
|-----------------------------------------------------------------------------------------------------------------------------------------------|-------------------------------------------------------------------------------------------------------------------------------------------------------|----------------------------------------------------------------------------------------------|
| 280 Select the ACTIVATE button. | The system displays a message indicating that an invalid number of Hellfire Missiles has been entered.
•3.2.1.1.1.5 | <input checked="" type="checkbox"/> S <input type="checkbox"/> SA <input type="checkbox"/> U |
| 290 Click on the OK button. | The display returns to the vehicle customization display. | <input checked="" type="checkbox"/> S <input type="checkbox"/> SA <input type="checkbox"/> U |
| 300 Select the Hellfire missiles entry and specify a weapons load of 6 Hellfire missiles. | The display reflects the custom Hellfire selection.
•3.2.1.1.1.4
•3.2.1.1.1.11 (ammo) | <input checked="" type="checkbox"/> S <input type="checkbox"/> SA <input type="checkbox"/> U |
| 310 Select the ACTIVATE button. | The system displays a message indicating that an invalid number of Stinger Missiles <i>Hydra Rockets</i> has been entered.
•3.2.1.1.1.5 | <input checked="" type="checkbox"/> S <input type="checkbox"/> SA <input type="checkbox"/> U |
| 320 Click on the OK button. | The display returns to the vehicle customization display. | <input checked="" type="checkbox"/> S <input type="checkbox"/> SA <input type="checkbox"/> U |
| 330 Select the Stinger <i>Hydra</i> entry and specify a weapons load of 38 <i>39</i> Stingers . <i>Hydra</i> | The display reflects the custom Stinger selection.
•3.2.1.1.1.4
•3.2.1.1.1.11 (ammo) | <input checked="" type="checkbox"/> S <input type="checkbox"/> SA <input type="checkbox"/> U |
| 340 Select the ACTIVATE button. | The system displays a message indicating that an invalid number of Hydra Rockets has been entered.
•3.2.1.1.1.5 | <input checked="" type="checkbox"/> S <input type="checkbox"/> SA <input type="checkbox"/> U |
| 350 Click on the OK button. | The display returns to the vehicle customization display. | <input checked="" type="checkbox"/> S <input type="checkbox"/> SA <input type="checkbox"/> U |
| 360 Select the Hydra 70 M151 (10 lb.) entry and specify a weapons load of 38. | The display reflects the custom Hydra selection.
•3.2.1.1.1.4
•3.2.1.1.1.11 (ammo) | <input checked="" type="checkbox"/> S <input type="checkbox"/> SA <input type="checkbox"/> U |

370 Select the ACTIVATE button.

The display reflects the custom weapons selections. The weapons load is within the quantity and weight requirements as noted below:

S SA U

- 6 Hellfires @ 101 lbs. ea.
- 2 Stingers @ 22.6 lbs. ea.
- 3@ Hydras @ 20.6 lbs. ea.
- 360 Rounds HEI @ 0.224 lbs. ea.
- Fuel @ 1600 lbs.
- 2 man crew @ 200 lbs. ea.
- Aircraft @ 7500 lbs.

=====
Total Weight: 10,973.44 lbs.

A display appears showing the activated simulators, 8B FRED assigned to A Company, placed) After a short time the RWA is activated as an RAH-66 Comanche, the image generator visuals and sound come on.

- 3.2.1.1.1.4
- 3.2.1.1.1.5 (weapons wt.)
- 3.2.1.1.1.7
- 3.2.1.1.1.8 (fuel wt.)
- 3.2.1.1.1.10 (1 sim) See Appendix A, Note 1
- 3.2.1.1.1.11 See Appendix A, Note 2

380 Click on the Overview button.

The Overview menu is displayed.

S SA U

5.2.3 Set Up Tactical Operation Center - The steps in this subparagraph consist of instructions for initializing the Tactical Operation Center.

<u>Step</u>	<u>Operator/System Action</u>	<u>Expected Result</u>
390	Select the Command Post Initialization Option and GO to the next menu.	A display appears showing Command Post selections.
400	Select the Tactical Operation Center (TOC) Option and GO to the next menu.	A Tactical Operations Center display appears.

Status (Check One)
 S SA U

S SA U

- | | | |
|---------------------------------------------------------------------------------------------------------------------------------------------------------|----------------------------------------------------------------------------------------------------------------------|----------------------------------------------------------------------------------------------|
| 410 Specify the Tactical Operation Center's alignment as US, located at ES962648, with a configuration of 4 HUMMVs in a square. Click on the OK button. | A display appears showing the Command Post selections, the Tactical Operations Center (TOC) selection is greyed out. | <input checked="" type="checkbox"/> S <input type="checkbox"/> SA <input type="checkbox"/> U |
| 420 Click on the CANCEL _{OK} button. | The Overview menu is displayed. | <input checked="" type="checkbox"/> S <input type="checkbox"/> SA <input type="checkbox"/> U |

5.2.4 Set Up Targets - The steps in this subparagraph consist of instructions for initializing the Gunnery Targets.

- | <u>Step</u> | <u>Operator/System Action</u> | <u>Expected Result</u> | <u>Status</u>
(Check One) |
|-------------|------------------------------------------------------------------------------------------------------------------------------------------------------------------------------------------------------------------------------------------------------------------------------------------------------------------------------------------------------------------------|-----------------------------------------------------------------------------------------------------------------------------------------------------------------------------------|----------------------------------------------------------------------------------------------|
| 430 | Select the Battlemaster Functions Option and GO to the next menu. | A display appears requesting the Battlemaster password. | <input checked="" type="checkbox"/> S <input type="checkbox"/> SA <input type="checkbox"/> U |
| 440 | Enter the Battlemaster password (foozball) and click on the OK button. | The Battlemaster Overview menu is displayed showing the following selectable options:
Displacement
Reconstitute
Gunnery Targets
Resume Initialization
End Exercise | <input checked="" type="checkbox"/> S <input type="checkbox"/> SA <input type="checkbox"/> U |
| 450 | Select the Gunnery Targets Option and GO to the next menu. | A Gunnery Targets list (empty) is displayed. | <input checked="" type="checkbox"/> S <input type="checkbox"/> SA <input type="checkbox"/> U |
| 460 | Enter the gunnery targets as:
Target 1, Attack RWA, US,
ES979700, Azimuth 0
Target 2, Scout RWA, US,
ES980705, Azimuth 0
Target 3, Tank, US,
ES980710, Azimuth 0
Target 4, Scout RWA, US,
ES980715, Azimuth 0
Target 5, Tank, US,
ES980720, Azimuth 0
Target 6, Tank, US,
ES980725, Azimuth 0
and click on the Overview button. | The Battlemaster Overview menu is displayed. | <input checked="" type="checkbox"/> S <input type="checkbox"/> SA <input type="checkbox"/> U |

5.2.5 Set Up Service Elements - The steps in this subparagraph consist of instructions for initializing the Service Elements.

<u>Step</u>	<u>Operator/System Action</u>	<u>Expected Result</u>	<u>Status</u> (Check One)
470	At the SIMNET SCC, click on the Start button to begin the initialization process.	A display appears showing the exercise types allowed.	<input checked="" type="checkbox"/> S <input type="checkbox"/> SA <input type="checkbox"/> U
480	Verify the selections as: Two forces, each viewing themselves as US and their opponents as threat, and the forces supported by the MCC as Both forces (local force-on-force). Go to the NEXT menu.	A display appears showing the geographic areas available for the exercise.	<input checked="" type="checkbox"/> S <input type="checkbox"/> SA <input type="checkbox"/> U
490	Verify the geographic area to be Ft. Knox 8/14/90, SW corner at ES450550, NE corner at FT200050. Go to the NEXT menu.	A display appears showing the exercise elements which may be included in the exercise.	<input checked="" type="checkbox"/> S <input type="checkbox"/> SA <input type="checkbox"/> U
500	Select/Deselect entries until only the Admin./Logistics Center is selected (denoted by an X in the box). Go to the NEXT menu.	A display appears showing additional exercise elements which may be included in the exercise.	<input checked="" type="checkbox"/> S <input type="checkbox"/> SA <input type="checkbox"/> U
510	Select/Deselect entries until only the Combat Service Support is selected (denoted by an X in the box). Go to the NEXT menu.	A display appears allowing the specification of participation for each company.	<input checked="" type="checkbox"/> S <input type="checkbox"/> SA <input type="checkbox"/> U
520	Specify participation as: A Company - Defense B Company - Offense C Company - Non-Participant D Company - Non-Participant Go to the NEXT menu.	A display appears allowing initiation of the initialization process or parameter redefinition.	<input checked="" type="checkbox"/> S <input type="checkbox"/> SA <input type="checkbox"/> U
530	Click on the OK button to start the initialization process.	An Overview Menu is displayed with the following selectable functions: Combat Service Support Simulator Allocation Admin./Log Center Vehicle Placement Battlemaster	<input checked="" type="checkbox"/> S <input type="checkbox"/> SA <input type="checkbox"/> U
540	Select the Admin./Log Center and GO to the next menu.	An Admin./Log Center Initialization display appears.	<input type="checkbox"/> S <input type="checkbox"/> SA <input type="checkbox"/> U

- | | | |
|------------------------------------------------------------------------------------------------------|---------------------------------------------------------------------------------------------------------------|----------------------------------------------------------------------------------------------|
| 550 Select the role of the ALOC as Shared and the ALOC location as ES964648. Click on the OK button. | The display returns to the Overview menu. The Admin/Log selection is greyed out. | <input checked="" type="checkbox"/> S <input type="checkbox"/> SA <input type="checkbox"/> U |
| 560 Select the Combat Service Support and GO to the next menu. | A Combat Service Support Initialization display appears. | <input checked="" type="checkbox"/> S <input type="checkbox"/> SA <input type="checkbox"/> U |
| 570 Select the Supply Depots and UMCP entry and go to the NEXT menu. | A display appears allowing division and brigade support areas to be defined. | <input checked="" type="checkbox"/> S <input type="checkbox"/> SA <input type="checkbox"/> U |
| 580 Specify all division and brigade locations to be ES953643 and go to the NEXT menu. | A display appears allowing confirmation or change to parameters and invocation of the initialization process. | <input checked="" type="checkbox"/> S <input type="checkbox"/> SA <input type="checkbox"/> U |
| 590 Click on the OK button. | The display returns to the Overview Menu. | <input checked="" type="checkbox"/> S <input type="checkbox"/> SA <input type="checkbox"/> U |
| 600 Select the Combat Service Support and go to the NEXT menu. | A Combat Service Support Initialization display appears. The Supply Depots and UMCP selection is greyed out. | <input checked="" type="checkbox"/> S <input type="checkbox"/> SA <input type="checkbox"/> U |
| 610 Select Battalion Combat Service Support and go to the NEXT menu. | A display appears allowing selection of the train organization type. | <input checked="" type="checkbox"/> S <input type="checkbox"/> SA <input type="checkbox"/> U |
| 620 Select the train type as Unit Trains and go to the NEXT menu. | A display appears allowing specification of the supporting platoon's location. | <input checked="" type="checkbox"/> S <input type="checkbox"/> SA <input type="checkbox"/> U |
| 630 Specify the platoon location as ES954643 and go to the NEXT menu. | A display appears showing the M97 ⁷ ammunition carrier loads. | <input checked="" type="checkbox"/> S <input type="checkbox"/> SA <input type="checkbox"/> U |
| 640 Select Display Load by Ammo Type by clicking on the Ammo Type circle. | The M97 ⁷ ammunition carrier loads are displayed by ammo type. | <input checked="" type="checkbox"/> S <input type="checkbox"/> SA <input type="checkbox"/> U |
| 650 Select a vehicle by clicking on a vehicle entry. | The vehicle's specific data is displayed. | <input checked="" type="checkbox"/> S <input type="checkbox"/> SA <input type="checkbox"/> U |
| 660 Select the vehicle side as Defense. | The display reflects the side selection. | <input checked="" type="checkbox"/> S <input type="checkbox"/> SA <input type="checkbox"/> U |
| 670 Display the initial load details by clicking in the box containing the initial ammunition load. | A display showing the depot contents and the vehicle contents is presented. | <input checked="" type="checkbox"/> S <input type="checkbox"/> SA <input type="checkbox"/> U |

- | | | |
|---------------------------------------------------------------------------------------------------------------------------------------------------------------------------------------------------------|------------------------------------------------------------------------------------------------------------------------|----------------------------------------------------------------------------------------------|
| 680 Unload the ammunition carrier by clicking on the vehicle's ammunition type, clicking on the left arrow, entering the load amount (the total load on the truck) and clicking on the Transfer button. | The selected ammunition is transferred from the truck to the depot. | <input checked="" type="checkbox"/> S <input type="checkbox"/> SA <input type="checkbox"/> U |
| 690 Repeat ammunition transfers until the vehicle is empty. | The ammunition truck load display reflects an empty truck. | <input checked="" type="checkbox"/> S <input type="checkbox"/> SA <input type="checkbox"/> U |
| 700 Select the Hellfire ammunition type from the depot ammunition selection list. | The Hellfire ammunition type entry is highlighted. | <input checked="" type="checkbox"/> S <input type="checkbox"/> SA <input type="checkbox"/> U |
| 710 Enter an amount of 4 and click on the Transfer button. | The specified number of Hellfire missiles is transferred to the ammunition carrier. | <input checked="" type="checkbox"/> S <input type="checkbox"/> SA <input type="checkbox"/> U |
| 720 Repeat the transfer steps for the following ammunition types:
Stinger Missiles - Load 4
Hydras 70 10 lb. M151- Load 4
20 mm HEI Rounds - Load 16 | The specified number of each ammunition type is transferred to the ammunition carrier. | <input checked="" type="checkbox"/> S <input type="checkbox"/> SA <input type="checkbox"/> U |
| 730 Click on the Done button. | The display returns to the vehicle specific data display. | <input checked="" type="checkbox"/> S <input type="checkbox"/> SA <input type="checkbox"/> U |
| 740 Click on the OK button and go to the next menu. | The display returns first to the M977 Ammunition Carrier's display and then to the Pallet Ammunition Carriers display. | <input checked="" type="checkbox"/> S <input type="checkbox"/> SA <input type="checkbox"/> U |
| 750 Verify that 10 pallet ammunition carriers are listed and go to the NEXT menu. | A display appears showing the M978 fuel carrier loads. | <input checked="" type="checkbox"/> S <input type="checkbox"/> SA <input type="checkbox"/> U |
| 760 Verify that 10 M978 fuel carriers are listed and go to the NEXT menu. | A display appears showing the maintenance teams. | <input checked="" type="checkbox"/> S <input type="checkbox"/> SA <input type="checkbox"/> U |
| 770 Verify that 10 maintenance teams are listed and go to the NEXT menu. | A display appears allowing confirmation or change to parameters and invocation of the initialization process. | <input checked="" type="checkbox"/> S <input type="checkbox"/> SA <input type="checkbox"/> U |

780 Click on the OK button.

The display changes to include a smaller display which states that the CSS parameters are being recorded. This display disappears after a short time and the display returns to the Overview Menu. The display on the Admin/Log console shows the pallet carrier status.

S SA U

5.2.6 Verify the Aircraft Position and Fly to the Refueling Point - The steps in this subpara aph consist of instructions for verifying the positional location of the aircraft at activation and for flying to the refueling waypoint.

Step	Operator/System Action	Expected Result	Status (Check One)
790	At the RWA System Console (gt-1), enter < (less than sign) to display the vehicle location at activation. Record the values displayed. X <u>50019.99</u> Y <u>5019.703</u> Z <u>201.464</u> UTM <u>ES950600</u>	The X,Y,Z and UTM coordinates of the aircraft location are displayed. The recorded values are approximately equivalent to: ES95026002 => (50020,5020). UTM 6-digits => ES950600 •3.2.1.1.2.10	<input checked="" type="checkbox"/> S <input type="checkbox"/> SA <input type="checkbox"/> U
800	At the RAH-66 Instrument Display, verify that the lubber line (indicates aircraft heading) is aligned with 0 degrees North.	The lubber line is aligned with N (North, 0 degrees). •3.2.1.1.2.11	<input checked="" type="checkbox"/> S <input type="checkbox"/> SA <input type="checkbox"/> U
810	At the RAH-66 softpanel, enter a waypoint (the refueling location) at ES956655, and select it for navigation.	The Situational Display shows a 1 indicating the waypoint position relative to the aircraft's current location and heading (represented by the center crosshairs). It also identifies the aircraft's current position (grid coordinates ES950600), the bearing to the waypoint (approx. 7 deg.) and the range to the waypoint (approx. 5510 m.).	<input checked="" type="checkbox"/> S <input type="checkbox"/> SA <input type="checkbox"/> U

820 Take off and fly a heading of ~~7~~ degrees (NNE) at an altitude of 200 - 250 feet and an airspeed of 80 - 90 knots. Fly until you reach the waypoint area (grid coordinates ES956655), and come to a hover at an altitude of 100 feet.

The visual displays show a river area similar to that shown below. The waypoint is situated along the river NNE of the "D".

S SA U

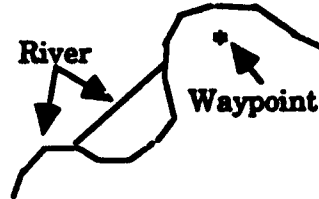

5.2.7 TOC Transmission of a Digital Message to the RAH-66 Requesting Status - The steps in this subparagraph consist of instructions for transmission and receipt of a digital message requesting status.

Step	Operator/System Action	Expected Result	Status (Check One)
830	At the TOC DMCC, select the Report (RPRT) option from the System Main Menu (SYS MAIN) by clicking on the bezel switch.	The Report (RPRT) Menu is displayed identifying the types of messages which may be sent (SPOT, MTO, SHOT, SPLASH, FREE TXT, REQT, and MOVCMO).	<input checked="" type="checkbox"/> S <input type="checkbox"/> SA <input type="checkbox"/> U
840	Select the Request (REQT) message option by clicking on the bezel switch.	A Request message display appears showing the entries which may be made in a Request message.	<input checked="" type="checkbox"/> S <input type="checkbox"/> SA <input type="checkbox"/> U
850	Select the Address (ADRS) of the RAH-66 by clicking on the bezel switch until the entry is highlighted.	The RAH-66 address is highlighted.	<input checked="" type="checkbox"/> S <input type="checkbox"/> SA <input type="checkbox"/> U
860	Select the Type of request being made as STATUS by clicking on the bezel switch until the entry is highlighted.	The request type STATUS is highlighted.	<input checked="" type="checkbox"/> S <input type="checkbox"/> SA <input type="checkbox"/> U
870	Send the Request message by clicking on the Send Routine (SND ROUT) button.	The button is momentarily highlighted. •3.2.1.2.2.2.1 (TOC, 1 player) •3.2.1.2.2.2.3 (TOC, send) •3.2.1.2.2.3.6 (pref-RWA) •3.2.1.2.2.3.6.1 (RWA) •3.2.1.2.2.3.6.2 (pref)	<input checked="" type="checkbox"/> S <input type="checkbox"/> SA <input type="checkbox"/> U

880 Return to the Message Queue Display (Access Mode) by clicking on the CLEAR and RETURN button, and then the MSGS button.

The display returns to the Message Queue Display, which shows an empty queue.
 *3.2.1.2.2.3.6.3 (Access Mode)

S SA U

890 Click on the SYS MAIN button.

The display returns to the System Main Menu (SYS MAIN).

S SA U

900 At the RAH-66 DMCC, verify the display of an incoming message icon box

The incoming message icon disappears.
 *3.2.1.2.2.1.6.4 (pref)

S SA U

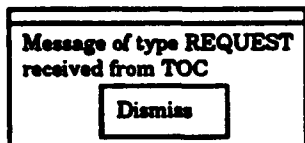

and dismiss the icon by clicking on the Dismiss button.

910 Select the Message (MSGS) option from the System Main Menu (SYS MAIN) by clicking on the bezel switch.

The Message (MSG) Menu is displayed identifying the messages presently in the message queue. The queue shows 1 routine Request Message from the TOC.

S SA U

920 Select the Request message received from the TOC by clicking on the PREV/NEXT bezel switches until the entry is highlighted.

The message entry is highlighted.

S SA U

930 Retrieve and display the Request message by clicking on the READ button.

The selected message is displayed and the message is acknowledged at the TOC.
 *3.2.1.2.2.3.1.2 (ack)
 *3.2.1.2.2.3.4.3

S SA U

940 Verify the message contents:
 REQUEST REPORT ROUTINE
 SENDER TOC
 SENT TO RAH-66
 FWD BY
 MSG SENT (date/time)
 XMIT LCN
 XMIT ALT 0 FEET

 REPORT DESIRED STATUS

The message content is as specified.

S SA U

where date/time is of the format
 26 1745 JUNE 95

950 Return to the Message Queue Display (Access Mode) by clicking on the Read button.

The display returns to the Message Queue Display. The queue shows 1 routine Request Message from the TOC.
 •3.2.1.2.2.3.4.3.a (Access & Retrieve Mode)

S SA U

960 Click on the SYS MAIN button.

The display returns to the System Main Menu (SYS MAIN).

S SA U

970 At the TOC DMCC, verify the display of a Message Acknowledgment

The message acknowledgment disappears.
 •3.2.1.2.2.2.3 (TOC, ack)
 •3.2.1.2.2.3.4.1 (auto ack)
 •3.2.1.2.2.3.4.2 (ack pref)

S SA U

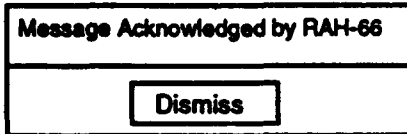

and dismiss the ~~tee~~ by clicking on the Dismiss button.

980 At the RAH-66 DMCC, select the Message (MSG) option from the System Main Menu (SYS MAIN) by clicking on the bezel switch.

The Message (MSG) Menu is displayed identifying the messages presently in the message queue. The queue shows 1 routine Request Message from the TOC

S SA U

990 Select the Request Message received from the TOC by clicking on the PREV/NEXT bezel switches until the entry is highlighted.

The message entry is highlighted.

S SA U

1000 Retrieve and display the Request message by clicking on the READ button.

The selected message is displayed.

S SA U

1010 Click on the SYS MAIN button.

The display returns to the System Main Menu (SYS MAIN).

S SA U

1020 At the TOC DMCC, verify that a second acknowledgment message is not sent.

The TOC display remains the same.
 •3.2.1.2.2.3.4

S SA U

5.2.8 RAH-66 Transmission of a Digital Message to the TOC Providing Status - The steps in this subparagraph consist of instructions for transmission and receipt of a digital message providing status.

<u>Step</u>	<u>Operator/System Action</u>	<u>Expected Result</u>	<u>Status</u> (Check One)
1030	At the RAH-66, record: Fuel Load: _____ lbs. Weapons Load: Hellfires: _____ Stingers: _____ Hydras: _____ 20 mm HEI: _____ Failed Equipment: _____ _____	The recorded information is available from the Situational, Instructional and Caution Displays. <i>Simulated Data was used for this portion of test.</i>	<input checked="" type="checkbox"/> S <input type="checkbox"/> SA <input type="checkbox"/> U
1040	At the RAH-66 DMCC, select the Report (RPRT) option from the System Main Menu (SYS MAIN) by clicking on the bezel switch.	The Report (RPRT) Menu is displayed identifying the types of messages which may be sent.	<input checked="" type="checkbox"/> S <input type="checkbox"/> SA <input type="checkbox"/> U
1050	Select the Free Text (FREE TXT) message option by clicking on the bezel switch.	A Free Text message display appears showing the entries which may be made in a Free Text message.	<input checked="" type="checkbox"/> S <input type="checkbox"/> SA <input type="checkbox"/> U
1060	Select the Address (ADRS) of the TOC by clicking on the bezel switch until the entry is highlighted.	The TOC address is highlighted.	<input checked="" type="checkbox"/> S <input type="checkbox"/> SA <input type="checkbox"/> U
1070	Enter the following text in the free text space, using the information recorded from the RAH-66: Fuel Load: (Fuel Load) lbs. Weapons Load: (Weapons Load) Failed Equipment: (Failed Equipment) Request Additional Fuel	The text is displayed as entered.	<input checked="" type="checkbox"/> S <input type="checkbox"/> SA <input type="checkbox"/> U
1080	Send the Free Text message by clicking on the Send Routine (SND ROUT) button.	The button is momentarily highlighted. •3.2.1.1.2.3 (wpns status) •3.2.1.1.2.7 (fuel status)	<input checked="" type="checkbox"/> S <input type="checkbox"/> SA <input type="checkbox"/> U
1090	Verify the accessibility of the Forward function by clicking on the CLEAR and RETURN button, then the MSGS button.	The REUSE button is available from the Message (MSG) Menu display. •3.2.1.2.2.3.6.3 (forward)	<input type="checkbox"/> S <input type="checkbox"/> SA <input type="checkbox"/> U

1100 Click on the SYS MAIN button.

The display returns to the System Main Menu (SYS MAIN).

<input checked="" type="checkbox"/>	<input type="checkbox"/>	<input type="checkbox"/>
S	SA	U

1110 At the TOC DMCC, verify the display of an incoming message icon box

The incoming message icon box disappears.
 •3.2.1.2.2.1.2 (notify)
 •3.2.1.2.2.1.4 (display msg icon)
 •3.2.1.2.2.1.6.4 (freet)

<input checked="" type="checkbox"/>	<input type="checkbox"/>	<input type="checkbox"/>
S	SA	U

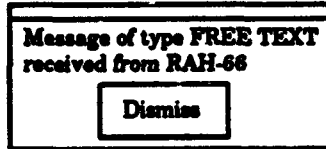

and dismiss the icon by clicking on the Dismiss button.

1120 Select the Message (MSG) option from the System Main Menu (SYS MAIN) by clicking on the bezel switch.

The Message (MSG) Menu is displayed identifying the messages presently in the message queue. The queue shows 1 routine Free Text Message from the RAH-66.

<input checked="" type="checkbox"/>	<input type="checkbox"/>	<input type="checkbox"/>
S	SA	U

1130 Select the Free Text message received from the RAH-66 by clicking on the PREV/NEXT bezel switches until the entry is highlighted.

The message entry is highlighted.
 •3.2.1.2.2.1.2 (msg in queue)
 •3.2.1.2.2.1.6.1 msg queued TOC

<input checked="" type="checkbox"/>	<input type="checkbox"/>	<input type="checkbox"/>
S	SA	U

1140 Retrieve and display the Free Text message by clicking on the READ button.

The selected message is displayed.
 •3.2.1.2.2.3 (TOC, view)

<input checked="" type="checkbox"/>	<input type="checkbox"/>	<input type="checkbox"/>
S	SA	U

1150 Verify the message contents:
 FREE TEXT MESSAGE ROUTINE
 SENDER RAH-66
 SENT TO TOC
 FWD BY
 MSG SENT (date/time)
 XMIT LCN
 XMIT ALT 0 FEET

The message content is as specified.

<input checked="" type="checkbox"/>	<input type="checkbox"/>	<input type="checkbox"/>
S	SA	U

Fuel Load: (Fuel Load) lbs.
 Weapons Load: (Weapons Load)
 Failed Equipment: (Failed Equipment)

Request Additional Fuel

where date/time is of the format
 26 1745 JUNE 95
 and the remaining free text information is that which was entered.

1160 Click on the SYS MAIN button.

The display returns to the System Main Menu (SYS MAIN).

<input checked="" type="checkbox"/>	<input type="checkbox"/>	<input type="checkbox"/>
S	SA	U

1170 At the RAH-66 DMCC, verify the display of a Message Acknowledgment

The message acknowledgment disappears.

<input checked="" type="checkbox"/>	<input type="checkbox"/>	<input type="checkbox"/>
S	SA	U

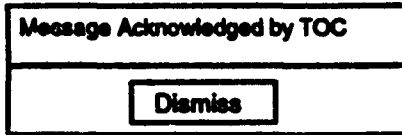

and dismiss the ~~box~~ by clicking on the Dismiss button.

5.2.9 Dispatch Refueling Vehicle - The steps in this subparagraph consist of instructions for dispatching a refueling vehicle.

<u>Step</u>	<u>Operator/System Action</u>	<u>Expected Result</u>	<u>Status</u> (Check One)						
1180	At the Admin./Log console, select the display which allows the control of the refueling vehicles (M977s) by selecting menu displays until the Fuel Truck Status Menu is displayed.	The Fuel Truck Status Menu is displayed.	<table border="0"> <tr> <td><input checked="" type="checkbox"/></td> <td><input type="checkbox"/></td> <td><input type="checkbox"/></td> </tr> <tr> <td>S</td> <td>SA</td> <td>U</td> </tr> </table>	<input checked="" type="checkbox"/>	<input type="checkbox"/>	<input type="checkbox"/>	S	SA	U
<input checked="" type="checkbox"/>	<input type="checkbox"/>	<input type="checkbox"/>							
S	SA	U							
1190	Select any available refueling vehicle (a vehicle is available if it's entry background is white (not patterned)), by clicking on the vehicle entry.	The Vehicle entry is highlighted. 3.2.1.1.2.6 (MCC selectable refueling vehicles)	<table border="0"> <tr> <td><input checked="" type="checkbox"/></td> <td><input type="checkbox"/></td> <td><input type="checkbox"/></td> </tr> <tr> <td>S</td> <td>SA</td> <td>U</td> </tr> </table>	<input checked="" type="checkbox"/>	<input type="checkbox"/>	<input type="checkbox"/>	S	SA	U
<input checked="" type="checkbox"/>	<input type="checkbox"/>	<input type="checkbox"/>							
S	SA	U							
1200	Click on the Dispatch button.	A Dispatch Fuel Truck Menu is displayed.	<table border="0"> <tr> <td><input checked="" type="checkbox"/></td> <td><input type="checkbox"/></td> <td><input type="checkbox"/></td> </tr> <tr> <td>S</td> <td>SA</td> <td>U</td> </tr> </table>	<input checked="" type="checkbox"/>	<input type="checkbox"/>	<input type="checkbox"/>	S	SA	U
<input checked="" type="checkbox"/>	<input type="checkbox"/>	<input type="checkbox"/>							
S	SA	U							
1210	Enter ES956655 as the coordinates and click on the Compute ETA button. Record the ETA <u>0250</u> minutes.	The computed Estimated Time of Arrival is displayed in the format 25 1344 Oct day time month	<table border="0"> <tr> <td><input checked="" type="checkbox"/></td> <td><input type="checkbox"/></td> <td><input type="checkbox"/></td> </tr> <tr> <td>S</td> <td>SA</td> <td>U</td> </tr> </table>	<input checked="" type="checkbox"/>	<input type="checkbox"/>	<input type="checkbox"/>	S	SA	U
<input checked="" type="checkbox"/>	<input type="checkbox"/>	<input type="checkbox"/>							
S	SA	U							
1220	Click on the Dispatch button to dispatch the refueling vehicle.	The display returns to the Fuel Truck Status Menu which shows the selected truck "enroute to" ES95606550 and its ETA.	<table border="0"> <tr> <td><input checked="" type="checkbox"/></td> <td><input type="checkbox"/></td> <td><input type="checkbox"/></td> </tr> <tr> <td>S</td> <td>SA</td> <td>U</td> </tr> </table>	<input checked="" type="checkbox"/>	<input type="checkbox"/>	<input type="checkbox"/>	S	SA	U
<input checked="" type="checkbox"/>	<input type="checkbox"/>	<input type="checkbox"/>							
S	SA	U							
1230	Verify that when the fuel truck arrives a message stating that the truck is ready is displayed. Click on the Roger button.	The notification message disappears.	<table border="0"> <tr> <td><input checked="" type="checkbox"/></td> <td><input type="checkbox"/></td> <td><input type="checkbox"/></td> </tr> <tr> <td>S</td> <td>SA</td> <td>U</td> </tr> </table>	<input checked="" type="checkbox"/>	<input type="checkbox"/>	<input type="checkbox"/>	S	SA	U
<input checked="" type="checkbox"/>	<input type="checkbox"/>	<input type="checkbox"/>							
S	SA	U							

5.2.10 TOC Transmission of a Digital Message Reply to the RAH-66 Stating Refueling Vehicle Status
 - The steps in this subparagraph consist of instructions for transmission and receipt of a digital message reply which states the status of the refueling vehicle.

<u>Step</u>	<u>Operator/System Action</u>	<u>Expected Result</u>	<u>Status</u> (Check One)
1240	At the TOC DMCC, select the Message (MSG) option from the System Main Menu (SYS MAIN) by clicking on the bezel switch.	The Message (MSG) Menu is displayed identifying the messages presently in the message queue. The queue shows 1 routine Free Text Message from the RAH-66.	<input checked="" type="checkbox"/> S <input type="checkbox"/> SA <input type="checkbox"/> U
1250	Select the Free Text message received from the RAH-66 by clicking on the PREV/NEXT bezel switches.	The message entry is highlighted.	<input checked="" type="checkbox"/> S <input type="checkbox"/> SA <input type="checkbox"/> U
1260	Reply to the Free Text message by clicking on the REPLY button.	The Report (RPRT) menu is displayed identifying the types of messages which may be sent as replies. •3.2.1.2.2.3.1.2 (reply)	<input checked="" type="checkbox"/> S <input type="checkbox"/> SA <input type="checkbox"/> U
1270	Select the Free Text (FREE TXT) message option by clicking on the bezel switch.	A Free Text message display appears showing the entries which may be made in a Free Text message. The RAH-66 address is highlighted.	<input checked="" type="checkbox"/> S <input type="checkbox"/> SA <input type="checkbox"/> U
1280	Enter the following in the free text space, using the recorded ETA value: Refueling vehicle will rendezvous at ES956655 in (ETA) minutes.	The text is displayed as entered.	<input checked="" type="checkbox"/> S <input type="checkbox"/> SA <input type="checkbox"/> U
1290	Send the Free Text message by clicking on the Send Urgent (SND URG) button.	The button is momentarily highlighted. •3.2.1.2.2.3.2.a (freet to RWA)	<input checked="" type="checkbox"/> S <input type="checkbox"/> SA <input type="checkbox"/> U
1300	Return to the Message Queue Display (Access Mode) by clicking on the CLEAR and RETURN button, and then the MSGS button.	The display returns to the Message Queue Display. •3.2.1.2.2.3.2.b (Access Mode) •3.2.1.2.2.3.2.3 (Access Mode)	<input checked="" type="checkbox"/> S <input type="checkbox"/> SA <input type="checkbox"/> U
1310	Click on the SYS MAIN button.	The display returns to the System Main Menu (SYS MAIN).	<input checked="" type="checkbox"/> S <input type="checkbox"/> SA <input type="checkbox"/> U

- 1320 At the RAH-66 DMCC, verify the display of an incoming message icon box

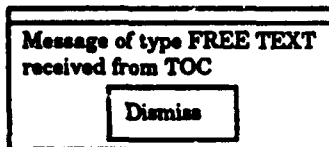

and dismiss the icon by clicking on the Dismiss button.

The incoming message icon disappears.

S SA U

- 1330 Select the Message (MSG) option from the System Main Menu (SYS MAIN) by clicking on the bezel switch.

The Message (MSG) Menu is displayed identifying the messages presently in the message queue. The queue shows 2 messages, 1 urgent Free Text Message from the TOC, 1 routine Request Message from the TOC.

S SA U

- 1340 Select the urgent Free Text message received from the TOC by clicking on the PREV/NEXT bezel switches until the entry is highlighted.

The message entry is highlighted.

S SA U

- 1350 Retrieve and display the Free Text message by clicking on the READ button.

The selected message is displayed.

S SA U

- 1360 Verify the message contents:
 FREE TEXT MESSAGE URGENT
 SENDER TOC
 SENT TO RAH-66
 FWD BY
 MSG SENT (date/time)
 XMIT LCN
 XMIT ALT 0 FEET

The message content is as specified.

S SA U

Refueling vehicle will rendezvous at ES956655 in (ETA) minutes.

where date/time is of the format 26 1745 JUNE 95 and ET is the recorded ETA.

- 1370 Click on the SYS MAIN button.

The display returns to the System Main Menu (SYS MAIN).

S SA U

- 1380 At the TOC DMCC, verify the display of a Message Acknowledgment

Message Acknowledged by RAH-66
Dismiss

and dismiss the icon by clicking on the Dismiss button.

The message acknowledgment disappears.

S SA U

- 1390 At the RAH-66 DMCC, select the Message (MSG) option from the System Main Menu (SYS MAIN) by clicking on the bezel switch.

The Message (MSG) Menu is displayed identifying the messages presently in the message queue. The queue shows 2 messages, 1 urgent Free Text Message from the TOC, 1 routine Request Message from the TOC.

S SA U

- 1400 Verify that the queue contains two messages:
A routine REQUEST message from the TOC
An urgent FREE TEXT message from the TOC

The queue contains the specified messages.

S SA U

- 1410 Select the routine Request message received from the TOC by clicking on the PREV/NEXT bezel switches until the entry is highlighted.

The message entry is highlighted.

S SA U

- 1420 Delete the message by clicking on the DELETE button.

The message is deleted from the queue. The queue shows 1 urgent Free Text message from the TOC.
•3.2.1.2.2.3.1.2 (delete)

S SA U

- 1430 Select the urgent Free Text message by clicking on the PREV/NEXT bezel switches until the entry is highlighted.

The message entry is highlighted.

S SA U

- 1440 Delete the message by clicking on the DELETE button.

The message is deleted from the queue; the queue is empty.
•3.2.1.2.2.3.5.1 (del msg)

S SA U

- 1450 Click on the SYS MAIN button.

The display returns to the System Main Menu (SYS MAIN).

S SA U

5.2.11 Land Aircraft and Refuel - The steps in this subparagraph consist of instructions for landing the aircraft and refueling.

Step	Operator/System Action	Expected Result	Status (Check One)		
			<input checked="" type="checkbox"/> S	<input type="checkbox"/> SA	<input type="checkbox"/> U
1460	When the refueling vehicle (M978) arrives and stops, land the RAH-66 within a 100 meter radius of the vehicle.	The refueling vehicle is visible and stationary.	<input checked="" type="checkbox"/> S	<input type="checkbox"/> SA	<input type="checkbox"/> U
1470	Record the fuel gauge level at the time of landing <u>1450</u> lbs. and the current time <u>2:30</u> .	The fuel level is available from the Instructional Display.	<input checked="" type="checkbox"/> S	<input type="checkbox"/> SA	<input type="checkbox"/> U
1480	Toggle the Master Weapons Arming switch from Armed to Safe.	The weapons arming switches are on safe.	<input checked="" type="checkbox"/> S	<input type="checkbox"/> SA	<input type="checkbox"/> U
1490	Refuel the RAH-66 by monitoring the fuel gauge, recording the time when refueling is complete (i.e. the tank is full 1690 lbs.). at <u>2:30 (less than 30 sec)</u>	The fuel gauge value rises until it shows a full load of fuel, 1690 lbs. •3.2.1.1.2.5 (fuel wt.) •3.2.1.1.2.6	<input checked="" type="checkbox"/> S	<input type="checkbox"/> SA	<input type="checkbox"/> U
1500	Verify the time of transfer against the amount transferred. Fuel is transferred at 30 gals/min. Each gallon weighs 6.5 lbs. Thus 195 lbs. are transferred per minute. Record the transfer rate: _____ lbs/min.	The time of transfer corresponds to the amount transferred. •3.2.1.1.2.8 (xfer time)	<input type="checkbox"/> S	<input type="checkbox"/> SA	<input type="checkbox"/> U
1510	Toggle the Master Weapons Arming Switch from Safe to Armed.	The weapons arming switches are on Armed.	<input checked="" type="checkbox"/> S	<input type="checkbox"/> SA	<input type="checkbox"/> U
1520	At the Admin/Log console, note the display of the following messages and dismiss each message by clicking on the Roger button. Fuel Truck N is servicing at ES95606550. Fuel Truck N is no longer servicing at ES95606550.	The messages are displayed until the Roger button has been selected.	<input checked="" type="checkbox"/> S	<input type="checkbox"/> SA	<input type="checkbox"/> U

5.2.12 TOC Transmission of a Digital Message to the FSE Ordering FSE Movement - The steps in this subparagraph consist of instructions for transmission and receipt of a digital message which orders the FSE to move to a new location.

<u>Step</u>	<u>Operator/System Action</u>	<u>Expected Result</u>	<u>Status</u> (Check One)		
			<input type="checkbox"/>	<input type="checkbox"/>	<input type="checkbox"/>
			S	SA	U
1530	At the TOC DMCC, select the Report (RPRT) option from the System Main Menu (SYS MAIN) by clicking on the bezel switch.	The Report (RPRT) Menu is displayed identifying the types of messages which may be sent.	<input checked="" type="checkbox"/>	<input type="checkbox"/>	<input type="checkbox"/>
1540	Select the Move Command (MOV CMD) message option by clicking on the bezel switch.	A Move Command message display appears showing the entries which may be made in a Move Command Message.	<input checked="" type="checkbox"/>	<input type="checkbox"/>	<input type="checkbox"/>
1550	Select the Address (ADRS) of the FSE by clicking on the bezel switch until the entry is highlighted.	The FSE address is highlighted.	<input checked="" type="checkbox"/>	<input type="checkbox"/>	<input type="checkbox"/>
1560	Select the Task as Move To (MOV TO) by clicking on the bezel switch until the entry is highlighted.	The MOV TO task entry is highlighted.	<input checked="" type="checkbox"/>	<input type="checkbox"/>	<input type="checkbox"/>
1570	Select When as Immediately (IMMED) by clicking on the bezel switch until the entry is highlighted.	The IMMED entry is highlighted.	<input checked="" type="checkbox"/>	<input type="checkbox"/>	<input type="checkbox"/>
1580	Select the Location (LCTN) as ES960645 by clicking on the bezel switch until the entry is highlighted.	The ES960645 location entry is highlighted.	<input checked="" type="checkbox"/>	<input type="checkbox"/>	<input type="checkbox"/>
1590	Select Who as YOU by clicking on the bezel switch until the entry is highlighted.	The YOU entry is highlighted.	<input checked="" type="checkbox"/>	<input type="checkbox"/>	<input type="checkbox"/>
1600	Send the Move Command message by clicking on the Send Routine (SND ROUT) button.	The button is momentarily highlighted. •3.2.1.2.2.3.6 (pref-MCC) •3.2.1.2.2.3.6.1 (MCC)	<input checked="" type="checkbox"/>	<input type="checkbox"/>	<input type="checkbox"/>
1610	Delete the message by clicking on the CLEAR and RETURN button.	The disp'ay returns to the Report (RPRT) menu. •3.2.1.2.2.3.6.3 (delete)	<input checked="" type="checkbox"/>	<input type="checkbox"/>	<input type="checkbox"/>
1620	Click on the SYS MAIN button.	The display returns to the System Main Menu (SYS MAIN).	<input checked="" type="checkbox"/>	<input type="checkbox"/>	<input type="checkbox"/>

1630 At the FSE DMCC, verify the display of an incoming message icon box

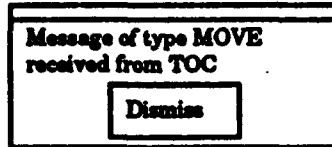

and dismiss the icon by clicking on the Dismiss button. box

The incoming message icon disappears.
 •3.2.1.2.2.1.3 (notify)
 •3.2.1.2.2.1.5 (display msg icon)

S SA U

1640 Select the Message (MSG) option from the System Main Menu (SYS MAIN) by clicking on the bezel switch.

The Message (MSG) Menu is displayed identifying the messages presently in the message queue. The queue shows 1 routine Move Command Message from the TOC.

S SA U

1650 Select the Move Command message received from the TOC by clicking on the PREV/NEXT bezel switches until the entry is highlighted.

The message entry is highlighted.
 •3.2.1.2.2.1.3 (msg in queue)
 •3.2.1.2.2.1.6.1 (msg queued fse)

S SA U

1660 Retrieve and display the Move Command message by clicking on the READ button.

The selected message is displayed.
 •3.2.1.2.2.2.3 (fse view)

S SA U

1670 Verify the message contents:
 MOVCMD REPORT ROUTINE
 SENDER TOC
 SENT TO FSE
 FWD BY
 MSG SENT (date/time)
 XMIT LCN
 XMIT ALT 0 FEET

 TASK MOV TO
 WHO YOU
 WHEN IMMED
 WHERE ES960645

The message content is as specified.

S SA U

where date/time is of the format
 26 1745 JUNE 95

1680 Click on the SYS MAIN button.

The display returns to the System Main Menu (SYS MAIN).

S SA U

1690 At the TOC DMCC, verify the display of a Message Acknowledgment

The message acknowledgment disappears.

S SA U

Message Acknowledged by FSE
Dismiss

and dismiss the icon by clicking on the Dismiss button.

5.2.13 FSE Forward of the Movement Command Digital Message to the RAH-66- The steps in this subparagraph consist of instructions for forwarding the FSE movement command to the RAH-66.

Step	Operator/System Action	Expected Result	Status (Check One)
1700	At the FSE DMCC, select the Message (MSG) option from the System Main Menu (SYS MAIN) by clicking on the bezel switch.	The Message (MSG) Menu is displayed identifying the messages presently in the message queue. The queue shows 1 routine Move Command Message from the TOC.	<input checked="" type="checkbox"/> S <input type="checkbox"/> SA <input type="checkbox"/> U
1710	Select the Move Command message received from the TOC by clicking on the PREV/NEXT bezel switches until the entry is highlighted.	The message entry is highlighted.	<input checked="" type="checkbox"/> S <input type="checkbox"/> SA <input type="checkbox"/> U
1720	Forward the message by clicking on the REUSE button.	A send message display appears allowing an address to be specified. •3.2.1.2.2.2.3 (FSE forward) •3.2.1.2.2.3.3 (pref to rwa) •3.2.1.2.2.3.3.1 (forward - rwa) •3.2.1.2.2.3.1.2 (forward) See Appendix A, Note 3	<input checked="" type="checkbox"/> S <input type="checkbox"/> SA <input type="checkbox"/> U
1730	Select the Address (ADRS) of the RAH-66 by clicking on the bezel switch until the entry is highlighted.	The RAH-66 address is highlighted.	<input checked="" type="checkbox"/> S <input type="checkbox"/> SA <input type="checkbox"/> U
1740	Send the Move Command message by clicking on the Send (SEND) button.	The button is momentarily highlighted.	<input checked="" type="checkbox"/> S <input type="checkbox"/> SA <input type="checkbox"/> U

1750 Return to the Message Queue Display (Access Mode) by clicking on the CLEAR and RETURN button, and then the MSGS button.

The display returns to the Message Queue Display. The queue shows 1 routine Move Command Message from the TOC.

S SA U

*3.2.1.2.2.3.3.3 (Access Mode)
*3.2.1.2.2.3.3.4 (Access Mode)

1760 At the RAH-66 DMCC, verify the display of an incoming message icon box

The incoming message icon box disappears.

S SA U

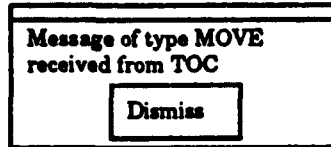

and dismiss the icon by clicking on the Dismiss button.

1770 Select the Message (MSG) option from the System Main Menu (SYS MAIN) by clicking on the bezel switch.

The Message (MSG) Menu is displayed identifying the messages presently in the message queue. The queue shows 1 routine Move Command Message from the TOC.

S SA U

1780 Select the Move Command message received from the TOC by clicking on the PREV/NEXT bezel switches until the entry is highlighted.

The message entry is highlighted.

S SA U

1790 Retrieve and display the Move Command message by clicking on the READ button.

The selected message is displayed.

S SA U

1800 Verify the message contents:
 MOVCMND REPORT ROUTINE
 SENDER TOC
 SENT TO RAH-66
 FWD BY FSE
 MSG SENT (date/time)
 XMIT LCN
 XMIT ALT 0 FEET

The message content is as specified.

S SA U

TASK MOV TO
 WHO YOU
 WHEN IMMED
 WHERE ES960645

where date/time is of the format
 26 1745 JUNE 95

1810 Click on the SYS MAIN button.

The display returns to the System Main Menu (SYS MAIN).

<input checked="" type="checkbox"/>	<input type="checkbox"/>	<input type="checkbox"/>
S	SA	U

1820 At the FSE DMCC, verify the display of a Message Acknowledgment

The message acknowledgment disappears.
•3.2.1.2.2.2.3 (fse ack)

<input checked="" type="checkbox"/>	<input type="checkbox"/>	<input type="checkbox"/>
S	SA	U

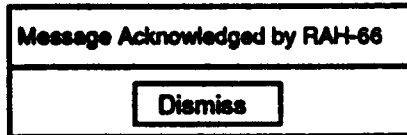

and dismiss the icon by clicking on the Dismiss button.

1830 Select the Move Command message received from the TOC by clicking on the PREV/NEXT bezel switches until the entry is highlighted.

The message entry is highlighted.

<input checked="" type="checkbox"/>	<input type="checkbox"/>	<input type="checkbox"/>
S	SA	U

1840 Delete the message by clicking on the DELETE button.

The message is deleted from the queue; the queue is empty.
•3.2.1.2.2.2.3 (fse delete)

<input checked="" type="checkbox"/>	<input type="checkbox"/>	<input type="checkbox"/>
S	SA	U

1850 Click on the SYS MAIN button.

The display returns to the System Main Menu (SYS MAIN).

<input checked="" type="checkbox"/>	<input type="checkbox"/>	<input type="checkbox"/>
S	SA	U

5.2.14 FSE Transmission of a Movement Command Digital Message to the RAH-66- The steps in this subparagraph consist of instructions for the transmission and receipt of a movement command for the RAH-66.

<u>Step</u>	<u>Operator/System Action</u>	<u>Expected Result</u>	<u>Status</u> (Check One)						
1860	At the FSE DMCC, select the Report (RPRT) option from the System Main Menu (SYS MAIN) by clicking on the bezel switch.	The Report (RPRT) Menu is displayed identifying the types of messages which may be sent.	<table border="0"> <tr> <td><input checked="" type="checkbox"/></td> <td><input type="checkbox"/></td> <td><input type="checkbox"/></td> </tr> <tr> <td>S</td> <td>SA</td> <td>U</td> </tr> </table>	<input checked="" type="checkbox"/>	<input type="checkbox"/>	<input type="checkbox"/>	S	SA	U
<input checked="" type="checkbox"/>	<input type="checkbox"/>	<input type="checkbox"/>							
S	SA	U							
1870	Select the Move Command (MOVCMD) message option by clicking on the bezel switch.	A Move Command Message display appears showing the entries which may be made in a Move Command message.	<table border="0"> <tr> <td><input checked="" type="checkbox"/></td> <td><input type="checkbox"/></td> <td><input type="checkbox"/></td> </tr> <tr> <td>S</td> <td>SA</td> <td>U</td> </tr> </table>	<input checked="" type="checkbox"/>	<input type="checkbox"/>	<input type="checkbox"/>	S	SA	U
<input checked="" type="checkbox"/>	<input type="checkbox"/>	<input type="checkbox"/>							
S	SA	U							
1880	Select the Address (ADRS) of the RAH-66 by clicking on the bezel switch until the entry is highlighted.	The RAH-66 address is highlighted.	<table border="0"> <tr> <td><input checked="" type="checkbox"/></td> <td><input type="checkbox"/></td> <td><input type="checkbox"/></td> </tr> <tr> <td>S</td> <td>SA</td> <td>U</td> </tr> </table>	<input checked="" type="checkbox"/>	<input type="checkbox"/>	<input type="checkbox"/>	S	SA	U
<input checked="" type="checkbox"/>	<input type="checkbox"/>	<input type="checkbox"/>							
S	SA	U							
1890	Select the Task as Hold At (HOLD AT) by clicking on the bezel switch until the entry is highlighted.	The HOLD AT task entry is highlighted.	<table border="0"> <tr> <td><input checked="" type="checkbox"/></td> <td><input type="checkbox"/></td> <td><input type="checkbox"/></td> </tr> <tr> <td>S</td> <td>SA</td> <td>U</td> </tr> </table>	<input checked="" type="checkbox"/>	<input type="checkbox"/>	<input type="checkbox"/>	S	SA	U
<input checked="" type="checkbox"/>	<input type="checkbox"/>	<input type="checkbox"/>							
S	SA	U							

1900 Select When as Immediately (IMMED) by clicking on the bezel switch until the entry is highlighted.

The IMMED entry is highlighted.

<input checked="" type="checkbox"/>	<input type="checkbox"/>	<input type="checkbox"/>
S	SA	U

1910 Select the Location (LCTN) as ES979700 by clicking on the bezel switch until the entry is highlighted.

The ES979700 location entry is highlighted.

<input checked="" type="checkbox"/>	<input type="checkbox"/>	<input type="checkbox"/>
S	SA	U

1920 Select Who as YOU by clicking on the bezel switch until the entry is highlighted.

The YOU entry is highlighted.

<input checked="" type="checkbox"/>	<input type="checkbox"/>	<input type="checkbox"/>
S	SA	U

1930 Send the Move Command message by clicking on the Send Urgent (SND URG) button.

The button is momentarily highlighted.
 *3.2.1.2.2.2.1 (fse, pref, 1 player) See Appendix A, Note 1
 *3.2.1.2.2.2.3 (fse. send)

<input checked="" type="checkbox"/>	<input type="checkbox"/>	<input type="checkbox"/>
S	SA	U

1940 Click on the CLEAR and RETURN button.

The display returns to the Report (RPRT) Menu.

<input checked="" type="checkbox"/>	<input type="checkbox"/>	<input type="checkbox"/>
S	SA	U

1950 Click on the SYS MAIN button.

The display returns to the System Main Menu (SYS MAIN).

<input checked="" type="checkbox"/>	<input type="checkbox"/>	<input type="checkbox"/>
S	SA	U

1960 At the MESSAGE MENU, verify the display of an incoming message icon box

The incoming message icon box disappears.

<input checked="" type="checkbox"/>	<input type="checkbox"/>	<input type="checkbox"/>
S	SA	U

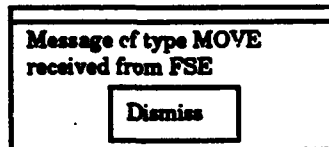

and dismiss the icon by clicking on the Dismiss button.

1970 Select the urgent Message (MSG) option from the System Main Menu (SYS MAIN) by clicking on the bezel switch.

The Message (MSG) Menu is displayed identifying the messages presently in the message queue. The queue shows 2 messages, 1 urgent Move Command Message from the FSE, 1 routine Move Command Message from the TOC.

<input checked="" type="checkbox"/>	<input type="checkbox"/>	<input type="checkbox"/>
S	SA	U

1980 Select the Move Command message received from the FSE by clicking on the PREV/NEXT bezel switches until the entry is highlighted.

The message entry is highlighted.

<input checked="" type="checkbox"/>	<input type="checkbox"/>	<input type="checkbox"/>
S	SA	U

1990 Retrieve and display the Move Command message by clicking on the READ button.

The selected message is displayed.

S SA U

2000 Verify the message contents:
 MOVCMO REPORT URGENT
 SENDER FSE
 SENT TO RAH-66
 FWD BY
 MSG SENT (date/time)
 XMIT LCN
 XMIT ALT 0 FEET

The message content is as specified.

S SA U

TASK HOLD AT
 WHO YOU
 WHEN IMMED
 WHERE ES979700

where date/time is of the format
 26 1745 JUNE 95

2010 Record the location from the Move Command ES979700.

The new location is available from the Move Command WHERE entry.

S SA U

2020 Delete the message by clicking on the DELETE button.

The display returns to the Message Queue display. The queue shows 1 routine Move Command Message from the TOC.
 •3.2.1.2.2.3.4.3.a (delete)
 •3.2.1.2.2.3.5.2
 See Appendix A, Note 3

S SA U

2030 Click on the SYS MAIN button.

The display returns to the System Main Menu (SYS MAIN).

S SA U

2040 At the FSE DMCC, verify the display of a Message Acknowledgment

The message acknowledgment disappears.

S SA U

Message Acknowledged by RAH-66
Dismiss

and dismiss the icon by clicking on the Dismiss button.

5.2.15 Fly the RAH-66 Aircraft towards the Target Area - The steps in this subparagraph consist of instructions for flying the RAH-66 aircraft toward the target area.

<u>Step</u>	<u>Operator/System Action</u>	<u>Expected Result</u>	<u>Status</u> (Check One)
2050	At the RAH-66 softpanel, enter the grid coordinates from the Move Command and select this waypoint as the navigation point.	The Situational Display shows a 2 indicating the waypoint position relative to the aircraft's current location and heading (represented by the center crosshairs). It also identifies the bearing and range to the waypoint.	<input checked="" type="checkbox"/> S <i>used target icon</i> <input type="checkbox"/> SA <input type="checkbox"/> U
2060	Take off again, flying at an altitude of 200 - 250 feet and an airspeed of 80 - 90 knots toward the target area. At approximately 4500 - 4000 meters from the target area, bring the aircraft to a hover at approximately 1200 - 1500 ft.	The aircraft flies to the new location and hovers.	<input checked="" type="checkbox"/> S <input type="checkbox"/> SA <input type="checkbox"/> U

5.2.16 FSE Transmission of a Digital Message to the RAH-66 and TOC Stating FSE Firing Status - The steps in this subparagraph consist of instructions for the transmission and receipt of a firing status message to the RAH-66 and the TOC.

<u>Step</u>	<u>Operator/System Action</u>	<u>Expected Result</u>	<u>Status</u> (Check One)
2070	At the FSE DMCC, select the Report (RPRT) option from the System Main Menu (SYS MAIN) by clicking on the bezel switch.	The Report (RPRT) Menu is displayed identifying the types of messages which may be sent.	<input checked="" type="checkbox"/> S <input type="checkbox"/> SA <input type="checkbox"/> U
2080	Select the Free Text (FREE TXT) message option by clicking on the bezel switch.	A Free Text message display appears showing the entries which may be made in the Free Text message.	<input checked="" type="checkbox"/> S <input type="checkbox"/> SA <input type="checkbox"/> U
2090	Select the Address (ADRS) of the RAH-66 and TOC group (RAHTOC) by clicking on the bezel switch until the entry is highlighted.	The RAHTOC group address is highlighted.	<input checked="" type="checkbox"/> S <input type="checkbox"/> SA <input type="checkbox"/> U

- | | | |
|-------------------------------------------------------------------------------------------------------------------------------------------------------------------------------------------------------------------------------------------------------------------|----------------------------------------------------------------------------------------------------------------------------------------------------------------------------------------------------------------|----------------------------------------------------------------------------------------------|
| 2100 Enter the following in the free text space: | The text is displayed as entered. | <input checked="" type="checkbox"/> S <input type="checkbox"/> SA <input type="checkbox"/> U |
| Firing on Target Ineffective,
Request RAH-66 Support. | | |
| 2110 Send the Free Text message by clicking on the Send Urgent (SND URG) button. | The button is momentarily highlighted.
•3.2.1.2.2.2.2 (FSE free text, 1 player)
•3.2.1.2.2.3.6 (freet - rwa, mcc)
•3.2.1.2.2.3.6.2 (freet) | <input checked="" type="checkbox"/> S <input type="checkbox"/> SA <input type="checkbox"/> U |
| 2120 Click on the CLEAR and RETURN button. | The display returns to the Report (RPRT) Menu. | <input checked="" type="checkbox"/> S <input type="checkbox"/> SA <input type="checkbox"/> U |
| 2130 Click on the SYS MAIN button. | The display returns to the System Main Menu (SYS MAIN). | <input checked="" type="checkbox"/> S <input type="checkbox"/> SA <input type="checkbox"/> U |
| 2140 At the RAH-66 DMCC, verify the display of an incoming message icon box. | The incoming message icon box disappears. | <input checked="" type="checkbox"/> S <input type="checkbox"/> SA <input type="checkbox"/> U |
| <div style="border: 1px solid black; padding: 5px; width: fit-content; margin: 0 auto;"> <p>Message of type FREE TEXT
received from FSE</p> <div style="border: 1px solid black; padding: 2px; display: inline-block; margin: 5px auto;">Dismiss</div> </div> | | |
| and dismiss the icon by clicking on the Dismiss button. | | |
| 2150 Select the Message (MSG) option from the System Main Menu (SYS MAIN) by clicking on the bezel switch. | The Message (MSG) Menu is displayed identifying the messages presently in the message queue. The queue shows 2 messages, 1 urgent Free Text Message from the FSE, 1 routine Move Command Message from the TOC. | <input checked="" type="checkbox"/> S <input type="checkbox"/> SA <input type="checkbox"/> U |
| 2160 Select the Free Text message received from the FSE by clicking on the PREV/NEXT bezel switches until the entry is highlighted. | The message entry is highlighted. | <input checked="" type="checkbox"/> S <input type="checkbox"/> SA <input type="checkbox"/> U |
| 2170 Retrieve and display the Free Text message by clicking on the READ button. | The selected message is displayed. | <input checked="" type="checkbox"/> S <input type="checkbox"/> SA <input type="checkbox"/> U |

2180 Verify the message contents:
 FREE TEXT MESSAGE URGENT
 SENDER FSE
 SENT TO RAHTOC
 FWD BY
 MSG SENT (date/time)
 XMIT LCN
 XMIT ALT 0 FEET

The message content is as specified.

S SA U

Firing on Target Ineffective,
 Request RAH-66 Support.

where date/time is of the format
 26 1745 JUNE 95

2190 Click on the SYS MAIN button.

The display returns to the System
 Main Menu (SYS MAIN).

S SA U

2200 At the FSE DMCC, verify the
 display of a Message
 Acknowledgment

The message acknowledgment
 disappears.

S SA U

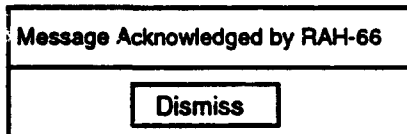

and dismiss the ~~icon~~ ^{box} by clicking on
 the Dismiss button.

2210 At the TOC DMCC, verify the
 display of an incoming message
~~icon box~~

The incoming message ~~icon box~~
 disappears.

S SA U

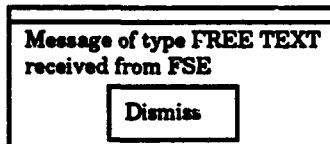

and dismiss the ~~icon~~ ^{box} by clicking on
 the Dismiss button.

2220 Select the Message (MSGS) option
 from the System Main Menu (SYS
 MAIN) by clicking on the bezel
 switch.

The Message (MSG) Menu is
 displayed identifying the messages
 presently in the message queue.
 The queue shows 2 messages, 1
 urgent Free Text Message from the
 FSE, 1 routine Free Text Message
 from the RAH-66.

S SA U

2230 Select the urgent Free Text message received from the FSE by clicking on the PREV/NEXT bezel switches until the entry is highlighted.

The message entry is highlighted.

S SA U

2240 Retrieve and display the Free Text message by clicking on the READ button.

The selected message is displayed.

S SA U

2250 Verify the message contents:
 FREE TEXT MESSAGE URGENT
 SENDER FSE
 SENT TO RAHTOC
 FWD BY
 MSG SENT (date/time)
 XMIT LCN ~~ES06006450~~
 XMIT ALT 0 ft.

The message content is as specified.

S SA U

Firing on Target Ineffective,
 Request RAH-66 Support.

where date/time is of '
 26 1745 JUNE 95

2260 Click on the SYS MAIN button.

The display returns to the System Main Menu (SYS MAIN).

S SA U

2270 At the FSE DMCC, verify the display of a Message Acknowledgment

The message acknowledgment disappears.

S SA U

Message Acknowledged by TOC
Dismiss

and dismiss the icon by clicking on the Dismiss button. *box*

5.2.17 FSE Transmission of a Digital Message to the RAH-66 Requesting Fire on Targets- The steps in this subparagraph consist of instructions for the transmission and receipt of a firing request to the RAH-66.

<u>Step</u>	<u>Operator/System Action</u>	<u>Expected Result</u>	<u>Status</u> (Check One)		
2280	At the FSE DMCC, select the Report (RPRT) option from the System Main Menu (SYS MAIN) by clicking on the bezel switch.	The Report (RPRT) Menu is displayed identifying the types of messages which may be sent.	<input checked="" type="checkbox"/> S	<input type="checkbox"/> SA	<input type="checkbox"/> U
2290	Select the Free Text (FREE TXT) message option by clicking on the bezel switch.	A Free Text message display appears showing the entries which may be made in a Free Text message.	<input checked="" type="checkbox"/> S	<input type="checkbox"/> SA	<input type="checkbox"/> U
2300	Select the Address (ADRS) of the RAH-66 by clicking on the bezel switch until the entry is highlighted.	The RAH-66 address is highlighted.	<input checked="" type="checkbox"/> S	<input type="checkbox"/> SA	<input type="checkbox"/> U
2310	Enter the following in the free text space: Request fire on targets.	The text is displayed as entered.	<input checked="" type="checkbox"/> S	<input type="checkbox"/> SA	<input type="checkbox"/> U
2320	Send the Free Text message by clicking on the Send Urgent (SND URG) button.	The button is momentarily highlighted.	<input checked="" type="checkbox"/> S	<input type="checkbox"/> SA	<input type="checkbox"/> U
2330	Click on the CLEAR and RETURN button.	The display returns to the Report (RPRT) Menu.	<input checked="" type="checkbox"/> S	<input type="checkbox"/> SA	<input type="checkbox"/> U
2340	Click on the SYS MAIN button.	The display returns to the System Main Menu (SYS MAIN).	<input checked="" type="checkbox"/> S	<input type="checkbox"/> SA	<input type="checkbox"/> U
2350	At the RAH-66 DMCC, verify the display of an incoming message icon box	The incoming message icon box disappears.	<input checked="" type="checkbox"/> S	<input type="checkbox"/> SA	<input type="checkbox"/> U

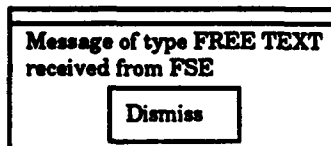

and dismiss the ~~icon~~ by clicking on the Dismiss button. ~~box~~

2360 Select the Message (MSG) option from the System Main Menu (SYS MAIN) by clicking on the bezel switch.

The Message (MSG) Menu is displayed identifying the messages presently in the message queue. The queue shows 3 messages, 2 urgent Free Text Messages from the FSE, 1 routine Move Command Message from the TOC.

S SA U

2370 Select the latest Free Text message received from the FSE by clicking on the PREV/NEXT bezel switches until the entry is highlighted.

The message entry is highlighted.

S SA U

2380 Retrieve and display the Free Text message by clicking on the READ button.

The selected message is displayed.

S SA U

2390 Verify the message contents:
 FREE TEXT MESSAGE URGENT
 SENDER FSE
 SENT TO RAH-66
 FWD BY
 MSG SENT (date/time)
 XMIT LCN
 XMIT ALT 0 FEET

The message content is as specified.

S SA U

Request fire on targets.

where date/time is of the format
 26 1745 JUNE 95

2400 Click on the SYS MAIN button.

The display returns to the System Main Menu (SYS MAIN).

S SA U

2410 At the FSE DMCC, verify the display of a Message Acknowledgment

The message acknowledgment disappears.

S SA U

Message Acknowledged by RAH-66
Dismiss

and dismiss the icon by clicking on the Dismiss button.

5.2.18 RAH-66 Reply to Request for Fire on Targets- The steps in this subparagraph consist of instructions for replying to the FSE's request for fire.

Step	Operator/System Action	Expected Result	Status (Check One)		
2420	At the RAH-66 DMCC, select the Message (MSG) option from the System Main Menu (SYS MAIN) by clicking on the bezel switch.	The Message (MSG) Menu is displayed identifying the messages presently in the message queue. The queue shows 3 messages, 2 urgent Free Text Messages from the FSE, 1 routine Move Command Message from the TOC.	<input checked="" type="checkbox"/> S	<input type="checkbox"/> SA	<input type="checkbox"/> U
2430	Select the latest Free Text message received from the FSE by clicking on the PREV/NEXT bezel switches until the entry is highlighted.	The message entry is highlighted.	<input checked="" type="checkbox"/> S	<input type="checkbox"/> SA	<input type="checkbox"/> U
2440	Reply to the Free Text message by clicking on the Reply button.	The Report (RPRT) menu is displayed identifying the types of messages which may be sent as replies. •3.2.1.2.2.3.2.1 (select msg from queue and reply)	<input checked="" type="checkbox"/> S	<input type="checkbox"/> SA	<input type="checkbox"/> U
2450	Select the Free Text (FREE TXT) message option by clicking on the bezel switch.	A Free Text message display appears showing the entries which may be made in a Free Text message. The FSE address is highlighted.	<input checked="" type="checkbox"/> S	<input type="checkbox"/> SA	<input type="checkbox"/> U
2460	Enter the following in the free text space: Roger	The text is displayed as entered.	<input checked="" type="checkbox"/> S	<input type="checkbox"/> SA	<input type="checkbox"/> U
2470	Send the Free Text message by clicking on the Send Routine (SND ROUT) button.	The button is momentarily highlighted. •3.2.1.2.2.3.2.2 (reply freet)	<input checked="" type="checkbox"/> S	<input type="checkbox"/> SA	<input type="checkbox"/> U
2480	Delete the message by clicking on the CLEAR and RETURN button, then the MSGS button and the DELETE button.	The display returns to the Report (RPRT) Menu, then the Message Queue Display. The queue shows 2 messages, 1 urgent Free Text Message from the FSE, 1 routine Move Command Message from the TOC. •3.2.1.2.2.3.2.b (delete) •3.2.1.2.2.3.2.3 (delete)	<input checked="" type="checkbox"/> S	<input type="checkbox"/> SA	<input type="checkbox"/> U

2490 Click on the SYS MAIN button.

The display returns to the System Main Menu (SYS MAIN).

<input checked="" type="checkbox"/>	<input type="checkbox"/>	<input type="checkbox"/>
S	SA	U

2500 At the FSE DMCC, verify the display of an incoming message icon box

The incoming message icon box disappears.

<input checked="" type="checkbox"/>	<input type="checkbox"/>	<input type="checkbox"/>
S	SA	U

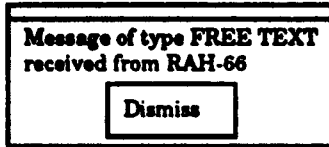

and dismiss the icon by clicking on the Dismiss button.

2510 Select the Message (MSG) option from the System Main Menu (SYS MAIN) by clicking on the bezel switch.

The Message (MSG) Menu is displayed identifying the messages presently in the message queue. The queue shows 1 routine Free Text Message from the RAH-66.

<input checked="" type="checkbox"/>	<input type="checkbox"/>	<input type="checkbox"/>
S	SA	U

2520 Select the Free Text message received from the RAH-66 by clicking on the PREV/NEXT bezel switches until the entry is highlighted.

The message entry is highlighted.

<input checked="" type="checkbox"/>	<input type="checkbox"/>	<input type="checkbox"/>
S	SA	U

2530 Retrieve and display the Free Text message by clicking on the READ button.

The selected message is displayed.
•3.2.1.2.2.3.1.1

<input checked="" type="checkbox"/>	<input type="checkbox"/>	<input type="checkbox"/>
S	SA	U

2540 Verify the message contents:
 FREE TEXT MESSAGE ROUTINE
 SENDER RAH-66
 SENT TO FSE
 FWD BY
 MSG SENT (date/time)
 XMIT LCN
 XMIT ALT 0 FEET

The message content is as specified.

<input checked="" type="checkbox"/>	<input type="checkbox"/>	<input type="checkbox"/>
S	SA	U

Roger

where date/time is of the format
 26 1745 JUNE 95

2550 Click on the SYS MAIN button.

The display returns to the System Main Menu (SYS MAIN).

<input checked="" type="checkbox"/>	<input type="checkbox"/>	<input type="checkbox"/>
S	SA	U

2560 At the RAH-66 DMCC, verify the display of a Message Acknowledgment

The message acknowledgment disappears.

S SA U

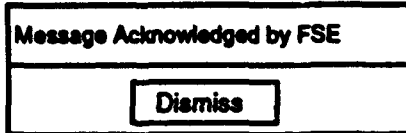

and dismiss the icon by clicking on the Dismiss button.

2570 Select the Message (MSG) option from the System Main Menu (SYS MAIN) by clicking on the bezel switch.

The Message (MSG) Menu is displayed identifying the messages presently in the message queue. The queue shows 2 messages, 1 urgent Free Text Message from the FSE, 1 routine Move Command Message from the TOC.

S SA U

2580 Select the Move Command message received from the TOC by clicking on the PREV/NEXT bezel switch until the entry is highlighted.

The message entry is highlighted.

S SA U

2590 Delete the message by clicking on the DELETE button.

The message is deleted from the queue. The queue shows 1 urgent Free Text Message from the FSE.
•3.2.1.2.2.1.6 (delete)

S SA U

2600 Click on the SYS MAIN button.

The display returns to the System Main Menu (SYS MAIN).

S SA U

5.2.19 Fire on the First Target with the Stinger - The steps in this subparagraph consist of instructions for firing a Stinger missile at the first target.

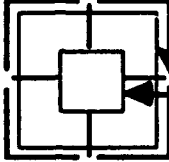
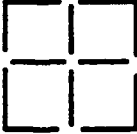
Step	Operator/System Action	Expected Result	Status (Check One)
2610	At the Pilot's position, select the Stinger missile by moving the Weapons Action Switch down.	The Pilot's Weapons Selection Indicator is lit green, the CPG's Weapons Selection Indicator is lit red for pilot control of the Missile (MSL) 2 weapon. ATAS reticles are displayed.  Out the Window Reticle  Sensor Reticle Dashed Box (<i>outside constraints</i>)	<input checked="" type="checkbox"/> S <input type="checkbox"/> SA <input type="checkbox"/> U
2620	Verify that the reticle is approximately equivalent in size to that displayed on the CPG sensor screen, occupying ~ 10% of the horizontal screen space and ~13% of the vertical screen space.	The reticle is the correct size. •ATAC II - 3.2.2.2	<input checked="" type="checkbox"/> S <input type="checkbox"/> SA <input type="checkbox"/> U
2630	Deselect the Stinger missile by moving the Weapons Action Switch down.	The Weapons Selection Indicators are not lit for Missile (MSL) 2. The OTW reticle disappears and the sensor reticle converts to 	<input checked="" type="checkbox"/> S <input type="checkbox"/> SA <input type="checkbox"/> U
2640	Position the aircraft so that it is 15 - 20 degrees off of the heading for the waypoint.	The aircraft is 15 - 20 degrees off of the heading for the waypoint.	<input checked="" type="checkbox"/> S <input type="checkbox"/> SA <input type="checkbox"/> U

2650 At the CPG position, select the Stinger missile by moving the Weapons Action Switch down.

The CPG's Weapons Selection Indicator is lit green, the Pilot's lit red for CPG control of the Missile (MSL) 2 weapon. ATAS reticles are displayed.



Out the Window Reticle

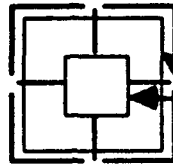

Sensor Reticle

Dashed Box (*outside Constraints*)

- ATAC II - 3.2.10.3
- ATAC II - 3.2.11.1
- ATAC II - 3.2.12 (CPG)

2660 Using the Manual Tracker Controller, move the sensor line of sight until the target (Attack RWA) is within the dashed box of the reticle. Pull the weapons trigger to the first detent.

The movement of the reticle corresponds to the control of the manual tracker. An aural seek tone (buzz type tone) is heard when the weapons trigger is at the first detent.



- ATAC II - 3.2.11.2

2670 Engage the Auto Tracker by pressing the IAT/MAN switch.

The Auto Tracker is engaged, the reticle locks onto the target but the target is not within the firing constraints of the weapon. The target is centered in the reticle.

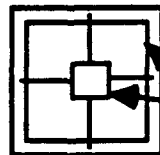

Dashed Box (*outside Constraints*)

2680 At the pilot position, move the aircraft so that it is within 10 degrees of the target heading.

The target is within the lock-on cone dimensions of +/- 10 degrees.



2690 At the (CPG) position, pull the weapons trigger to the first detent.

The sensor reticle converts to

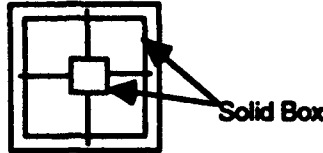

and the OTW reticle moves to frame the target. The OTW reticle has a black dot in its center.

- ATAC II - 3.2.3
- ATAC II - 3.2.10.2

2700 Deselect the Stinger missile by moving the Weapons Action Switch down.

The Weapons Selection Indicators are not lit for Missile (MSL) 2. The Out-The-Window reticle disappears, the sensor reticle goes to

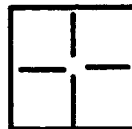

2710 Disengage the Auto Tracker and return the sensor view to fixed forward.

The sensor view returns to fixed forward; the word "FORWARD" is displayed in the lower right hand corner of the display. The reticle goes to



2720 At the pilot position, move the aircraft to within visible (out-the-window) range of the target (Attack RWA) and hover at approximately 1000 - 1200 ft. The visibility range is 3.5 km.

The target comes into view.



2730 Position the aircraft so that it is 15 - 20 degrees off of the heading for the target.

The aircraft is 15 - 20 degrees off of the heading for the target.



2740 At the CPG position, select the Stinger missile by moving the Weapons Action Switch down.

The CPG's Weapons Selection Indicator is lit green, the Pilot's lit red for CPG control of the Missile (MSL) 2 weapon. The reticles are displayed.

S SA U

2750 Using the Manual Tracker Controller, move the sensor line of sight until the target (Attack RWA) is within the dashed box of the reticle. Pull the weapons trigger to the first detent.

The movement of the reticle corresponds to the control of the manual tracker. An aural seek tone (buzz type tone) is heard when the weapons trigger is at the first detent.

S SA U

2760 Engage the Auto Tracker by pressing the IAT/MAN switch.

The Auto Tracker is engaged, the reticle locks onto the target. The target is centered in the reticle.

S SA U

2770 At the pilot position, move the aircraft so that it is within 10 degrees of the target heading. At the CPG position, pull the weapons trigger to the first detent.

Lock-on is achieved and an aural lock-on tone is heard. The normal Out-The-Window reticle tracks to the target location. The sensor reticle changes from dashed boxes to

S SA U

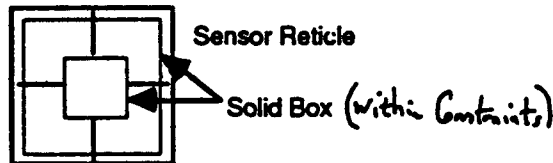

- ATAC II - 3.2.10.1
- ATAC II - 3.2.11.3

2780 Fire a Stinger Missile at the target by pressing the weapons trigger to the second detent.

A missile is fired at the locked-on target. Once the missile is fired, the OTW reticle returns to the center, the sensor reticle remains solid until the trigger is released.

S SA U

2790 At the CPG position, deselect the Stinger missile by moving the Weapons Action Switch down.

The Weapons Selection Indicators are not lit for Missile (MSL) 2. The sensor reticle returns to its standard format (dashed box with line of sight indicators).
•ATAC II - 3.2.8

S SA U

2800 Disengage the Auto Tracker and return the sensor view to fixed forward.

The sensor view returns to fixed forward; the word "FORWARD" is displayed in the lower right hand corner of the display.

S SA U

2810 At the softpanel, enter a new waypoint (target location) at ES980705 and select it for navigation.

The Situational Display shows the entered waypoint, its heading and range.

S SA U

2820 At the pilot position, position the aircraft so that it is 25 - 30 degrees off of the heading for the new target.

The aircraft is 25 - 30 degrees off of the heading for the target.

S SA U

5.2.20 Fire on the Second and Third Targets using the Hellfire - The steps in this subparagraph consist of instructions for firing Hellfire missiles at the second (scout RWA) and third (tank) targets.

Step	Operator/System Action	Expected Result	Status (Check One)
2830	At the CPG position, select the Hellfire missile by moving the Weapons Action Switch to the right.	The CPG's Weapons Selection Indicator is lit green, the Pilot's lit red for CPG control of Missile (MSL) 1. The sensor reticle changes from	<input checked="" type="checkbox"/> S <input type="checkbox"/> SA <input type="checkbox"/> U

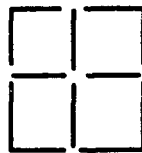

to

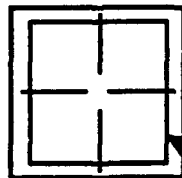

Dashed Box

2840 Using the Manual Tracker Controller, move the sensor line of sight until the target (Scout RWA) is within the box of the reticle.

The movement of the reticle corresponds to the control of the manual tracker.

S SA U

2850 Engage the Auto Tracker by pressing the IAT/MAN switch.

The Auto Tracker is engaged, but the aircraft is outside of the lock-on constraints (+/- 20 degrees). The reticle appears as

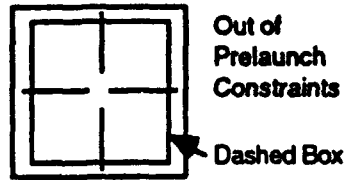

•ATAC II - 3.3.1.26.2

2860 At the pilot position, move the aircraft so that it is within 20 degrees of the target heading.

Lock-on is achieved. The reticle converts from

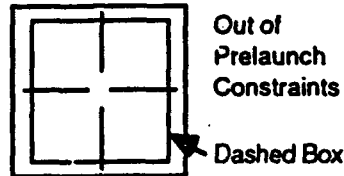

to

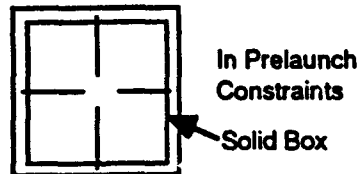

•ATAC II - 3.3.1.26.1

•ATAC II - 3.3.1.27

2870 At the CPG position, pull the laser rangefinder trigger to the second detent.

The laser range finder distance is displayed on the sensor display as a 4 digit integer number with a leading zero (5 digits total).

•ATAC II - 3.3.1.14



2880 Verify that the laser rangefinder mode and status are displayed in the upper left hand corner of the sensor display.

The phrases "RNG" and "ARM" appear in the upper left hand corner of the sensor display in the format:

RNG
ARM

•ATAC II - 3.3.1.18

•ATAC II - 3.3.1.19

•ATAC II - 3.3.1.21



- | | | |
|----------------------------------------------------------------------------------------------------------------------------------------------------------------------------------------------------------|-------------------------------------------------------------------------------------------------------------------------------------------------------------------------------------------------------------------------------------------------|----------------------------------------------------------------------------------------------|
| 2890 At the CPG position, pull the weapons trigger. | The missile is fired and travels to the location indicated by the laser. | <input checked="" type="checkbox"/> S <input type="checkbox"/> SA <input type="checkbox"/> U |
| | <ul style="list-style-type: none"> •ATAC II - 3.3.1.5 •ATAC II - 3.3.1.17 (LOBL) •ATAC II - 3.3.1.13 (local) See Note 4, Appendix A | |
| 2900 Disengage the Auto Tracker and return the sensor view to fixed forward. | The sensor view returns to fixed forward and the word "FORWARD" is displayed in the lower right hand corner of the display. | <input checked="" type="checkbox"/> S <input type="checkbox"/> SA <input type="checkbox"/> U |
| 2910 At the softpanel, enter a target UTM coordinate point as a Hellfire destination point. Enter the UTM coordinates ES980710. | The UTM coordinates are entered as a Hellfire destination point as indicated by the entry Target --> ES980710 following the 18th waypoint. <ul style="list-style-type: none"> •ATAC II - 3.3.1.10 •ATAC II - 3.3.1.30.2 | <input checked="" type="checkbox"/> S <input type="checkbox"/> SA <input type="checkbox"/> U |
| 2920 Verify that the CPG sensor display shows the range to the Hellfire destination point in the format NXXXX where XXXX is the range to the coordinate in meters (with a leading zero, 5 digits total). | The range is displayed. <ul style="list-style-type: none"> •ATAC II - 3.3.1.15 | <input checked="" type="checkbox"/> S <input type="checkbox"/> SA <input type="checkbox"/> U |
| | <i>ND2788</i> | |
| 2930 Using the Manual Tracker Controller, move the sensor line of sight until the target (Tank) is within the box of the reticle. | The movement of the reticle corresponds to the control of the manual tracker. | <input checked="" type="checkbox"/> S <input type="checkbox"/> SA <input type="checkbox"/> U |
| 2940 Engage the Auto Tracker by pressing the IAT/MAN switch. | The Auto Tracker is engaged. The reticle is centered on the target. | <input checked="" type="checkbox"/> S <input type="checkbox"/> SA <input type="checkbox"/> U |
| 2950 At the CPG position, pull the weapons trigger to fire the missile. | The missile is fired and travels to a location forward of the specified UTM grid coordinates/target. <ul style="list-style-type: none"> •ATAC II - 3.3.1.11 | <input checked="" type="checkbox"/> S <input type="checkbox"/> SA <input type="checkbox"/> U |
| 2960 Using the Manual Tracker Controller, move the sensor line of sight until the target (Scout RWA) is within the box of the reticle. | The movement of the reticle corresponds to the control of the manual tracker. | <input checked="" type="checkbox"/> S <input type="checkbox"/> SA <input type="checkbox"/> U |

- | | | |
|-------------------------------------------------------------------------------------------------------------------------------------------------------------------|--------------------------------------------------------------------------------------------------------|----------------------------------------------------------------------------------------------|
| 2970 Engage the Auto Tracker by pressing the IAT/MAN switch. If necessary, at the Pilot position, move the aircraft to within the firing constraints. | The Auto Tracker is engaged. The reticle is centered on the target. | <input checked="" type="checkbox"/> S <input type="checkbox"/> SA <input type="checkbox"/> U |
| 2980 At the CPG position, pull the weapons trigger and then the laser range finder trigger to the second detent. Hold the laser trigger until the weapon impacts. | The missile is fired and travels to the location indicated by the laser.
•ATAC II - 3.3.1.17 (LOAL) | <input checked="" type="checkbox"/> S <input type="checkbox"/> SA <input type="checkbox"/> U |
| 2990 Deselect the Hellfire missile by moving the Weapons Action Switch to the right. | The Weapons Selection Indicators are not lit for Missile (MSL) 1.
•ATAC II - 3.3.1.25 | <input checked="" type="checkbox"/> S <input type="checkbox"/> SA <input type="checkbox"/> U |

5.2.21 Fire on the Fourth and Fifth Targets with the Hydras and Gun - The steps in this subparagraph consist of instructions for firing the Hydra rockets and the gun.

<u>Step</u>	<u>Operator/System Action</u>	<u>Expected Result</u>	<u>Status</u> (Check One)
3000	At the RAH-66 softpanel, enter a waypoint (target 4 location) at ES980720 and select it for navigation.	The Situational Display shows a ^{stat} stat indicating the waypoint position relative to the aircraft's current location and heading.	<input checked="" type="checkbox"/> S <input type="checkbox"/> SA <input type="checkbox"/> U
3010	Fly towards the fourth target until it comes into view.	The fourth target, a scout helicopter, comes into view.	<input checked="" type="checkbox"/> S <input type="checkbox"/> SA <input type="checkbox"/> U
3020	Fire on the target expending 2 Hydra rockets (1 shot).	The rockets flyout and impact.	<input checked="" type="checkbox"/> S <input type="checkbox"/> SA <input type="checkbox"/> U
3030	The fifth target is directly north of the fourth target 500 meters. If it is not already visible, fly north until it comes into view.	The fifth target, a tank, comes into view.	<input checked="" type="checkbox"/> S <input type="checkbox"/> SA <input type="checkbox"/> U
3040	Fire on the target expending 10 - 12 rounds of ammunition. Record the total number of vehicles destroyed <u>4</u> . Return to a hover at 100 ft. <i>two tanks left</i>	The ammunition is fired.	<input checked="" type="checkbox"/> S <input type="checkbox"/> SA <input type="checkbox"/> U

5.2.22 RAH-66 Transmission of a Digital Message to the TOC with Number of Kills- The steps in this subparagraph consist of instructions for transmission and receipt of a message to the TOC giving the number of targets killed.

<u>Step</u>	<u>Operator/System Action</u>	<u>Expected Result</u>	<u>Status</u> (Check One)
3050	At the RAH-66 DMCC, select the Report (RPRT) option from the System: Main Menu (SYS MAIN) by clicking on the bezel switch.	The Report (RPRT) Menu is displayed identifying the types of messages which may be sent.	<input checked="" type="checkbox"/> S <input type="checkbox"/> SA <input type="checkbox"/> U
3060	Select the Free Text (FREE TXT) message option by clicking on the bezel switch.	A Free Text message display appears showing the entries which may be made in a Free Text message.	<input checked="" type="checkbox"/> S <input type="checkbox"/> SA <input type="checkbox"/> U
3070	Select the Address (ADRS) of the TOC by clicking on the bezel switch until the entry is highlighted.	The TOC address is highlighted.	<input checked="" type="checkbox"/> S <input type="checkbox"/> SA <input type="checkbox"/> U
3080	Enter the following in the free text area, using the recorded number of vehicles destroyed: Number of vehicles destroyed: (number destroyed)	The text is displayed as entered.	<input checked="" type="checkbox"/> S <input type="checkbox"/> SA <input type="checkbox"/> U
3090	Send the Free Text message by clicking on the Send Routine (SND ROUT) button.	The button is momentarily highlighted.	<input checked="" type="checkbox"/> S <input type="checkbox"/> SA <input type="checkbox"/> U
3100	Click on the CLEAR and RETURN button.	The display returns to the Report (RPRT) Menu.	<input checked="" type="checkbox"/> S <input type="checkbox"/> SA <input type="checkbox"/> U
3110	Click on the SYS MAIN button.	The display returns to the System Main Menu (SYS MAIN).	<input checked="" type="checkbox"/> S <input type="checkbox"/> SA <input type="checkbox"/> U
3120	At the TOC DMCC, verify the display of an incoming message icon box	The incoming message icon disappears.	<input checked="" type="checkbox"/> S <input type="checkbox"/> SA <input type="checkbox"/> U

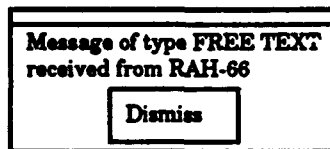

and dismiss the icon by clicking on the Dismiss button. ~~box~~

3130 Select the Message (MSG) option from the System Main Menu (SYS MAIN) by clicking on the bezel switch.

The Message (MSG) Menu is displayed identifying the messages presently in the message queue. The queue shows 3 messages, 1 urgent Free Text Message from the FSE, 2 routine Free Text Messages from the RAH-66.

S SA U

3140 Select the latest Free Text message received from the RAH-66 by clicking on the PREV/NEXT bezel switches until the entry is highlighted.

The message entry is highlighted.

S SA U

3150 Retrieve and display the Free Text message by clicking on the READ button.

The selected message is displayed.

S SA U

3160 Verify the message contents:
 FREE TEXT MESSAGE ROUTINE
 SENDER RAH-66
 SENT TO TOC
 FWD BY
 MSG SENT (date/time)
 XMIT LCN
 XMIT ALT 0 FEET

The message content is as specified.

S SA U

Number of vehicles destroyed:
 (number destroyed)

where date/time is of the format
 26 1745 JUNE 95 and number is
 the number of recorded vehicles
 destroyed.

3170 Click on the SYS MAIN button.

The display returns to the System Main Menu (SYS MAIN).

S SA U

3180 At the RAH-66 DMCC, verify the display of a Message Receive Acknowledgment

The message acknowledgment disappears.

S SA U

Message Acknowledged by TOC
Dismiss

and dismiss the icon by clicking on the Dismiss button. *b>x*

5.2.23 TOC Forward of the Number of Kills to the FSE and Requesting Status - The steps in this subparagraph consist of instructions for forwarding the number of targets killed to the FSE and requesting FSE status.

<u>Step</u>	<u>Operator/System Action</u>	<u>Expected Result</u>	<u>Status</u> (Check One)
3190	At the TOC DMCC, select the Message (MSG) option from the System Main Menu (SYS MAIN) by clicking on the bezel switch.	The Message (MSG) Menu is displayed identifying the messages presently in the message queue. The queue shows 3 messages, 1 urgent Free Text Message from the FSE, 2 routine Free Text Messages from the RAH-66.	<input checked="" type="checkbox"/> S <input type="checkbox"/> SA <input type="checkbox"/> U
3200	Select the latest Free Text message received from the RAH-66 by clicking on the PREV/NEXT bezel switches until the entry is highlighted.	The message entry is highlighted.	<input checked="" type="checkbox"/> S <input type="checkbox"/> SA <input type="checkbox"/> U
3210	Forward the message by clicking on the REUSE and INCLUDE button.	The Report (RPRT) Menu displayed identifying the types of messages which may be included with a forwarded message.	<input checked="" type="checkbox"/> S <input type="checkbox"/> SA <input type="checkbox"/> U
3220	Select the Request (REQT) message option by clicking on the bezel switch.	A Request message display appears showing the entries which may be made in a Request message.	<input checked="" type="checkbox"/> S <input type="checkbox"/> SA <input type="checkbox"/> U
3230	Select the Address (ADRS) of the FSE by clicking on the bezel switch until the entry is highlighted.	The FSE address is highlighted.	<input checked="" type="checkbox"/> S <input type="checkbox"/> SA <input type="checkbox"/> U
3240	Select the Type of request being made as STATUS by clicking on the bezel switch until the entry is highlighted.	The request type STATUS is highlighted.	<input checked="" type="checkbox"/> S <input type="checkbox"/> SA <input type="checkbox"/> U
3250	Send the message to be forwarded and the appended Request message by clicking on the Send Routine (SND ROUT) button.	The button is momentarily highlighted. •3.2.1.2.2.2.3 (toc forward) •3.2.1.2.2.3.3 (freet - mcc) •3.2.1.2.2.3.3.1 (forward mcc) •3.2.1.2.2.3.3.2 (pref)	<input checked="" type="checkbox"/> S <input type="checkbox"/> SA <input type="checkbox"/> U
3260	Click on the CLEAR and RETURN button.	The display returns to the Report (RPRT) Menu.	<input checked="" type="checkbox"/> S <input type="checkbox"/> SA <input type="checkbox"/> U
3270	Click on the SYS MAIN button.	The display returns to the System Main Menu (SYS MAIN).	<input checked="" type="checkbox"/> S <input type="checkbox"/> SA <input type="checkbox"/> U

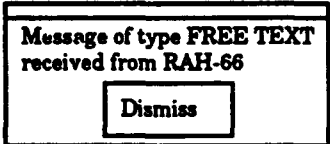
- 3280 Select the Message (MSG) option from the System Main Menu (SYS MAIN) by clicking on the bezel switch. The Message (MSG) Menu is displayed identifying the messages presently in the message queue. The queue shows 3 messages, 1 urgent Free Text Message from the FSE, 2 routine Free Text Messages from the RAH-66. S SA U
- 3290 Select the latest Free Text message received from the RAH-66 by clicking on the PREV/NEXT bezel switches until the entry is highlighted. The message entry is highlighted. S SA U
- 3300 Delete the message by clicking on the DELETE button. The message is deleted from the queue. The queue shows 2 messages, 1 urgent Free Text Message from the FSE, 1 routine Free Text Message from the RAH-66. *3.2.1.2.2.2.3 (toc delete) S SA U
- 3310 Click on the SYS MAIN button. The display returns to the System Main Menu (SYS MAIN). S SA U
- 3320 At the FSE DMCC, verify the display of an incoming message icon box and dismiss the icon by clicking on the Dismiss button.  S SA U
- 3330 Select the Message (MSG) option from the System Main Menu (SYS MAIN) by clicking on the bezel switch. The Message (MSG) Menu is displayed identifying the messages presently in the message queue. The queue shows 3 messages, 1 routine Request Message from the TOC, 2 routine Free Text Messages from the RAH-66. S SA U
- 3340 Select the latest Free Text message received from the RAH-66 by clicking on the PREV/NEXT bezel switches until the entry is highlighted. The message entry is highlighted. S SA U

3350 Retrieve and display the Free Text message by clicking on the READ button.

The selected message is displayed.

S SA U

3360 Verify the message contents:
FREE TEXT MESSAGE ROUTINE
SENDER RAH-66
SENT TO FSE
FWD BY TOC
MSG SENT (date/time)
XMIT LCN
XMIT ALT 0 FEET

The message content is as specified.

S SA U

Number of vehicles destroyed:
(number destroyed)

where date/time is of the format
26 1745 JUNE 95 and number is
the number of recorded vehicles
destroyed.

3370 Return to the message queue by clicking on the READ button.

The display returns to the message queue.

S SA U

3380 Verify the display of an incoming message icon box

The incoming message icon box disappears.

S SA U

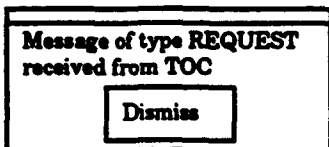

and dismiss the icon by clicking on the Dismiss button.

3390 Select the Request message received by the TOC by clicking on the PREV/NEXT bezel switches until the entry is highlighted.

The message entry is highlighted.

S SA U

3400 Retrieve and display the Request message by clicking on the READ button.

The selected message is displayed.

S SA U

3410 Verify the message contents:
 REQUEST MESSAGE ROUTINE
 SENDER TOC
 SENT TO FSE
 FWD BY
 MSG SENT (date/time)
 XMIT LCN
 XMIT ALT 0 FEET
 REPORT DESIRED STATUS

The message content is as specified.

S SA U

where date/time is of the format
 26 1745 JUNE 95.

3420 Click on the SYS MAIN button.

The display returns to the System
 Main Menu (SYS MAIN).

S SA U

3430 At the TOC DMCC, verify the
 display of a Message
 Acknowledgment (for the
 forwarded message)

The message acknowledgment
 disappears.

S SA U

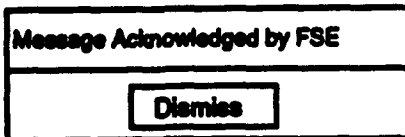

and dismiss the icon by clicking on
 the Dismiss button.

3440 Verify the display of a second
 Message Acknowledgment (for the
 appended message)

The message acknowledgment
 disappears.

S SA U

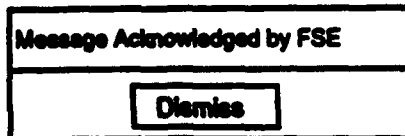

and dismiss the icon by clicking on
 the Dismiss button.

5.2.24 FSE Reply to RAH-66 Firing Status and FSE Status - The steps in this subparagraph consist of instructions for replying to the RAH-66's firing status message.

<u>Step</u>	<u>Operator/System Action</u>	<u>Expected Result</u>	<u>Status</u> (Check One)
3450	At the FSE DMCC, select the Message (MSG) option from the System Main Menu (SYS MAIN) by clicking on the bezel switch.	The Message (MSG) Menu is displayed identifying the messages presently in the message queue. The queue shows 3 messages, 1 routine Request Message from the TOC, 2 routine Free Text Messages from the RAH-66.	<input checked="" type="checkbox"/> S <input type="checkbox"/> SA <input type="checkbox"/> U
3460	Select the Request message received from the TOC by clicking on the PREV/NEXT bezel switches until the entry is highlighted.	The message entry is highlighted.	<input checked="" type="checkbox"/> S <input type="checkbox"/> SA <input type="checkbox"/> U
3470	Reply to the Request message by clicking on the REPLY button.	The Report (RPRT) Menu is displayed identifying the types of messages which may be sent as replies.	<input checked="" type="checkbox"/> S <input type="checkbox"/> SA <input type="checkbox"/> U
3480	Select the Free Text (FREE TXT) message option by clicking on the bezel switch.	A Free Text message display appears showing the entries which may be made in a Free Text message. The TOC address is highlighted.	<input checked="" type="checkbox"/> S <input type="checkbox"/> SA <input type="checkbox"/> U
3490	Enter the following text in the free text space: Good Work FSE Operational	The text is displayed as entered.	<input checked="" type="checkbox"/> S <input type="checkbox"/> SA <input type="checkbox"/> U
3500	Send the Free Text message by clicking on the Send Routine (SND ROUT) button.	The button is momentarily highlighted. •3.2.1.2.2.2.3 (fse reply)	<input checked="" type="checkbox"/> S <input type="checkbox"/> SA <input type="checkbox"/> U
3510	Click on the CLEAR and RETURN button.	The display returns to the Report (RPRT) Menu.	<input checked="" type="checkbox"/> S <input type="checkbox"/> SA <input type="checkbox"/> U
3520	Click on the SYS MAIN button.	The display returns to the System Main Menu (SYS MAIN).	<input checked="" type="checkbox"/> S <input type="checkbox"/> SA <input type="checkbox"/> U

3530 At the TOC DMCC, verify the display of an incoming message icon bar.

The incoming message icon bar disappears.

S SA U

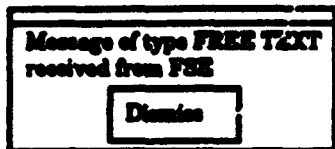

and dismiss the icon by clicking on the Dismiss button.

3540 Select the Message (MSG) option from the System Main Menu (SYS MAIN) by clicking on the bezel switch.

The Message (MSG) Menu is displayed identifying the messages presently in the message queue. The queue shows 3 messages, 1 urgent Free Text Message from the FSE, 1 routine Free Text Message from the FSE, 1 routine Free Text Message from the RAH-66.

S SA U

3550 Select the routine Free Text message received from the FSE by clicking on the PREV/NEXT bezel switches until the entry is highlighted.

The message entry is highlighted.

S SA U

3560 Retrieve and display the Free Text message by clicking on the READ button.

The selected message is displayed.

S SA U

3570 Verify the message contents:
 FREE TEXT MESSAGE ROUTINE
 SENDER FSE
 SENT TO TOC
 FWD BY
 MSG SENT (date/time)
 XMIT LCN
 XMIT ALT 0 ft.

The message content is as specified.

S SA U

Good Work
 FSE Operational

where date/time is of the format
 26 1745 JUNE 95

3580 Click on the SYS MAIN button.

The display returns to the System Main Menu (SYS MAIN).

S SA U

3590 At the FSE DMCC, verify the display of a Message Acknowledgment

The message acknowledgment disappears.

Status
(Check One)

S SA U

Message Acknowledged by TOC

Dismiss

and dismiss the ~~jeer~~ by clicking on the Dismiss button. ~~box~~

5.2.25 TOC Forward of FSE Reply to RAH-66 Firing Status and FSE Status to RAH-66 - The steps in this subparagraph consist of instructions for the TOC to forward the FSE Reply to the RAH-66's Firing Status (which included the FSE Status) to the RAH-66.

<u>Step</u>	<u>Operator/System Action</u>	<u>Expected Result</u>	Status (Check One)
3600	At the TOC DMCC, select the Message (MSG) option from the System Main Menu (SYS MAIN) by clicking on the bezel switch.	The Message (MSG) Menu is displayed identifying the messages presently in the message queue. The queue shows 3 messages, 1 urgent Free Text Message from the FSE, 1 routine Free Text Message from the FSE, 1 routine Free Text Message from the RAH-66.	<input checked="" type="checkbox"/> S <input type="checkbox"/> SA <input type="checkbox"/> U
3610	Select the routine Free Text message received from the FSE by clicking on the PREV/NEXT bezel switches until the entry is highlighted.	The message entry is highlighted.	<input checked="" type="checkbox"/> S <input type="checkbox"/> SA <input type="checkbox"/> U
3620	Forward the message by clicking on the REUSE and INCLUDE button.	The Report (RPRT) Menu is displayed identifying the types of messages which may be included with forwarded message.	<input checked="" type="checkbox"/> S <input type="checkbox"/> SA <input type="checkbox"/> U
3630	Select the Free Text (FREE TXT) message option by clicking on the bezel switch.	A Free Text message display appears showing the entries which may be made in a Free Text message.	<input checked="" type="checkbox"/> S <input type="checkbox"/> SA <input type="checkbox"/> U
3640	Select the Address (ADRS) of the RAH-66 by clicking on the bezel switch until the entry is highlighted.	The RAH-66 address is highlighted.	<input checked="" type="checkbox"/> S <input type="checkbox"/> SA <input type="checkbox"/> U

3650 Enter the following text in the free text space:

Congratulations!!

The text is displayed as entered.

S SA U

3660 Send the Free Text message to be forwarded and the appended Free Text message by clicking on the Send Routine (SND ROUT) button.

The button is momentarily highlighted.
 •3.2.1.2.2.3.3 (forward to rwa, fret)
 •3.2.1.2.2.3.3.2 (fret)

S SA U

3670 Click on the CLEAR and ^{RETURN}ROUTINE button.

The display returns to the Report (RPRT) Menu.

S SA U

3680 Click on the SYS MAIN button.

The display returns to the System Main Menu (SYS MAIN).

S SA U

3690 At the RAH-66 DMCC, verify the display of an incoming message icon box

The incoming message icon box disappears.

S SA U

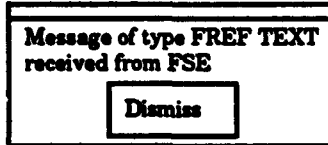

and dismiss the icon by clicking on the Dismiss button. box

3700 Select the Message (MSG) option from the System Main Menu (SYS MAIN) by clicking on the bezel switch.

The Message (MSG) Menu is displayed identifying the messages presently in the message queue. The queue shows 3 messages, 1 urgent Free Text Message from the FSE, 1 routine Free Text Message from the TOC, 1 routine Free Text Message from the FSE.

S SA U

3710 Select the routine Free Text message received from the FSE by clicking on the PREV/NEXT bezel switches until the entry is highlighted.

The message entry is highlighted.

S SA U

3720 Retrieve and display the Free Text message by clicking on the READ button.

The selected message is displayed.

S SA U

3730 Verify the message contents:
FREE TEXT MESSAGE ROUTINE
SENDER FSE
SENT TO RAH-66
FWD BY TOC
MSG SENT (date/time)
XMIT LCN
XMIT ALT 0 FEET

Good Work
FSE Operational

where date/time is of the format
26 1745 JUNE 95

The message content is as specified.

S SA U

3740 Return to the message queue by clicking on the READ button.

The display returns to the message queue.

S SA U

3750 Verify the display of an incoming message icon box

The incoming message icon box disappears.

S SA U

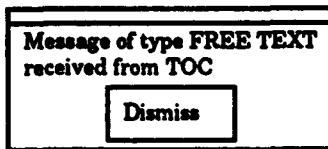

and dismiss the icon by clicking on the Dismiss button.

3760 Select the Free Text message received from the TOC by clicking on the PREV/NEXT bezel switches until the entry is highlighted.

The message entry is highlighted.

S SA U

3770 Retrieve and display the Free Text message by clicking on the READ button.

The selected message is displayed.

S SA U

3780 Verify the message contents:
FREE TEXT MESSAGE ROUTINE
SENDER TOC
SENT TO RAH-66
FWD BY
MSG SENT (date/time)
XMIT LCN
XMIT ALT 0 FEET

Congratulations!!

where date/time is of the format
26 1745 JUNE 95.

The message content is as specified.

S SA U

3790 Click on the SYS MAIN button.

The display returns to the System Main Menu (SYS MAIN).

S SA U

3800 At the TOC DMCC, verify the display of a Message Acknowledgment (for the forwarded message)

The message acknowledgment disappears.

S SA U

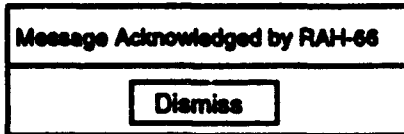

and dismiss the icon by clicking on the Dismiss button. box

3810 Verify the display of a second Message Acknowledgment (for the appended message)

The message acknowledgment disappears.

S SA U

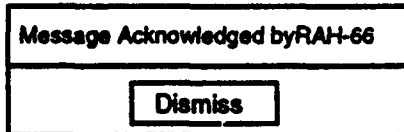

and dismiss the icon by clicking on the Dismiss button. box

5.2.26 TOC Replies to RAH-66 Firing Status with a Move Command Message - The steps in this subparagraph consist of instructions for the TOC to reply to the RAH-66's Firing Status. The reply takes the form of a Move Command with additional orders to rearm.

Step	Operator/System Action	Expected Result	Status (Check One)
3820	At the TOC DMCC, select the Message (MSG) option from the System Main Menu (SYS MAIN) by clicking on the bezel switch.	The Message (MSG) Menu is displayed identifying the messages presently in the message queue. The queue shows 3 messages, 1 urgent Free Text Message from the FSE, 1 routine Free Text Message from the FSE, 1 routine Free Text Message from the RAH-66.	<input checked="" type="checkbox"/> S <input type="checkbox"/> SA <input type="checkbox"/> U
3830	Select the Free Text message received from the RAH-66 by clicking on the PREV/NEXT bezel switches until the entry is highlighted.	The message entry is highlighted.	<input checked="" type="checkbox"/> S <input type="checkbox"/> SA <input type="checkbox"/> U

3840 Reply to the Free Text message by clicking on the REPLY button.

The Report (RPRT) Menu is displayed identifying the types of messages which may be sent as replies.

S SA U

3850 Select the Move Command (MOV CMD) message option by clicking on the bezel switch.

A Move Command message display appears showing the entries which may be made in a Move Command message. The RAH-66 address is highlighted.

S SA U

3860 Select the Task as Move To (MOV TO) by clicking on the bezel switch until the entry is highlighted.

The MOV TO task entry is highlighted.

S SA U

3870 Select When as Immediately (IMMED) by clicking on the bezel switch until the entry is highlighted.

The IMMED entry is highlighted.

S SA U

3880 Select the Location (LCTN) as ES967650 by clicking on the bezel switch until the entry is highlighted.

The ES967650 location entry is highlighted.

S SA U

3890 Select Who as YOU by clicking on the bezel switch until the entry is highlighted.

The YOU entry is highlighted.

S SA U

3900 Enter the following text in the ~~lower~~ free text space:
upper
Standby to Rearm.

The text is displayed as entered.

S SA U

3910 Send the Move Command message by clicking on the Send Urgent (SND URG) button.

The button is momentarily highlighted.
•3.2.1.2.2.2.3 (toc reply)
•3.2.1.2.2.3.2.a (reply pref to rwa)
•3.2.1.2.2.3.2.2 (reply pref)

S SA U

3920 Click on the CLEAR and RETURN button.

The display returns to the Report (RPRT) Menu.

S SA U

3930 Click on the SYS MAIN button.

The display returns to the System Main Menu (SYS MAIN).

S SA U

3940 At the RAH-66 DMCC, verify the display of an incoming message icon

The incoming message icon disappears.

S SA U

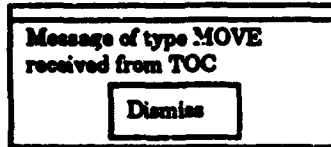

and dismiss the icon by clicking on the Dismiss button.

3950 Select the Message (MSG) option from the System Main Menu (SYS MAIN) by clicking on the bezel switch.

The Message (MSG) Menu is displayed identifying the messages presently in the message queue. The queue shows 4 messages, 1 urgent Move Command Message from the TOC, 1 urgent Free Text Message from the FSE, 1 routine Free Text Message from the TOC, 1 routine Free Text Message from the FSE.

S SA U

3960 Select the Move Command message received from the TOC by clicking on the PREV/NEXT bezel switches until the entry is highlighted.

The message entry is highlighted.

S SA U

3970 Retrieve and display the Move Command message by clicking on the READ button.

The selected message is displayed.

S SA U

3980 Verify the message contents:
 MOVCMD REPORT URGENT
 SENDER TOC
 SENT TO RAH-66
 FWD BY
 MSG SENT (date/time)
 XMIT LCN
 XMIT ALT 0 FEET

The message content is as specified.

S SA U

TASK MOV TO
 WHO YOU
 WHEN IMMED
 WHERE ES967650

Stand by to rearm.

where date/time is of the format
 26 1745 JUNE 95

3990 Record the new grid coordinates
E5967Δ50

The new grid coordinates are available from the Move Command.

S SA U

4000 Click on the SYS MAIN button.

The display returns to the System Main Menu (SYS MAIN).

S SA U

4010 At the TOC DMCC, verify the display of a Message Acknowledgment

The message acknowledgment disappears.

S SA U

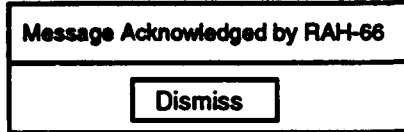

and dismiss the icon by clicking on the Dismiss button.

5.2.27 The RAH-66 Forwards its Move Command Message to the FSE - The steps in this subparagraph consist of instructions for the RAH-66 to forward its Move Command to the FSE.

<u>Step</u>	<u>Operator/System Action</u>	<u>Expected Result</u>	<u>Status</u> (Check One)
4020	At the RAH-66 DMCC, select the Message (MSG) option from the System Main Menu (SYS MAIN) by clicking on the bezel switch.	The Message (MSG) Menu is displayed identifying the messages presently in the message queue. The queue shows 4 messages, 1 urgent Move Command Message from the TOC, 1 urgent Free Text Message from the FSE, 1 routine Free Text Message from the TOC, 1 routine Free Text Message from the FSE.	<input checked="" type="checkbox"/> S <input type="checkbox"/> SA <input type="checkbox"/> U
4030	Select the Move Command message received from the TOC by clicking on the PREV/NEXT bezel switches until the entry is highlighted.	The message entry is highlighted.	<input checked="" type="checkbox"/> S <input type="checkbox"/> SA <input type="checkbox"/> U
4040	Forward the message by clicking on the REUSE button.	A send message display appears allowing an address to be specified.	<input checked="" type="checkbox"/> S <input type="checkbox"/> SA <input type="checkbox"/> U
4050	Select the Address (ADRS) of the FSE by clicking on the bezel switch until the entry is highlighted.	The FSE address is highlighted.	<input checked="" type="checkbox"/> S <input type="checkbox"/> SA <input type="checkbox"/> U
4060	Send the Move Command to be forwarded by clicking on the SEND button.	The button is momentarily highlighted. •3.2.1.2.2.3.3 (forward pref to mcc)	<input checked="" type="checkbox"/> S <input type="checkbox"/> SA <input type="checkbox"/> U

4070 Verify the accessibility of the Delete function by clicking on the CLEAR and RETURN button, then the MSGS button.

The delete function is accessible from the Message (MSG) Menu.
 •3.2.1.2.2.3.3.3 (delete from forward)
 •3.2.1.2.2.3.3.4 (delete from forward)

S SA U

4080 Click on the SYS MAIN button.

The display returns to the System Main Menu (SYS MAIN).

S SA U

4090 At the FSE DMCC, verify the display of an incoming message icon

The incoming message icon disappears.

S SA U

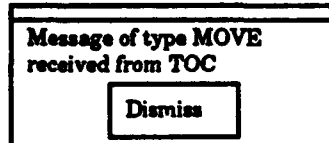

and dismiss the icon by clicking on the Dismiss button.

4100 Select the Message (MSGS) option from the System Main Menu (SYS MAIN) by clicking on the bezel switch.

The Message (MSG) Menu is displayed identifying the messages presently in the message queue. The queue shows 4 messages, 1 urgent Move Command Message, 1 routine Request Message from the TOC, 2 routine Free Text Messages from the RAH-66.

S SA U

4110 Select the Move Command message received from the TOC by clicking on the PREV/NEXT bezel switches until the entry is highlighted.

The message entry is highlighted.

S SA U

4120 Retrieve and display the Free Text message by clicking on the READ button.

The selected message is displayed.

S SA U

4130 Verify the message contents:
 MOVCMO REPORT URGENT
 SENDER TOC
 SENT TO FSE
 FWD BY RAH-66
 MSG SENT (date/time)
 XMIT LCN
 XMIT ALT 0 FEET

The message content is as specified.

S SA U

TASK MOV TO
 WHO YOU
 WHEN IMMED
 WHERE ES967650

Stand by to rearm.

where date/time is of the format
 26 1745 JUNE 95

4140 Click on the SYS MAIN button.

The display returns to the System Main Menu (SYS MAIN).

S SA U

4150 At the RAH-66 DMCC, verify the display of a Message Acknowledgment

The message acknowledgment disappears.

S SA U

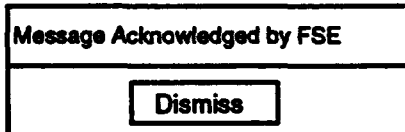

and dismiss the icon by clicking on the Dismiss button.

5.2.28 Dispatch Rearming Vehicle - The steps in this subparagraph consist of instructions for dispatch of a rearming vehicle.

Step	Operator/System Action
4160	At the Admin/Log console, select the display which allows the control of the rearming vehicles (M978s) by selecting menu displays until the Ammunition Truck Status Menu is displayed.

Expected Result
The Ammunition Truck Status Menu is displayed.

Status (Check One)
 S SA U

- | | | |
|-----------------------------------------------------------------------------------------------------------------------------------|-----------------------------------------------------------------------------------------------------------------------|----------------------------------------------------------------------------------------------|
| 4170 Select the rearming vehicle whose ammunition load is compatible with the RAH-66, by clicking on the vehicle entry. | The Vehicle entry is highlighted. (3.2.1.1.2.2 (MCC selectable rearm vehicles)) | <input checked="" type="checkbox"/> S <input type="checkbox"/> SA <input type="checkbox"/> U |
| 4180 Click on the Dispatch button. | The Dispatch Ammunition Truck Menu is displayed. | <input checked="" type="checkbox"/> S <input type="checkbox"/> SA <input type="checkbox"/> U |
| 4190 Enter ES967650 as the coordinates and click on the Compute ETA button. Record the ETA <u>4</u>
<u>0331</u> minutes. | The computed Estimated Time of Arrival is displayed in the format

25 1403 Oct
day time month | <input checked="" type="checkbox"/> S <input type="checkbox"/> SA <input type="checkbox"/> U |
| 4200 Click on the Dispatch button to dispatch the rearming vehicle. | The display returns to the Ammunition Truck Status Menu which shows the truck "enroute to" ES96706500 and its ETA. | <input checked="" type="checkbox"/> S <input type="checkbox"/> SA <input type="checkbox"/> U |
| 4210 Verify that when the rearm truck arrives, a message stating that the truck is ready is displayed. Click on the Roger button. | The truck ready message is displayed and the notification message disappears once the Roger button has been selected. | <input checked="" type="checkbox"/> S <input type="checkbox"/> SA <input type="checkbox"/> U |

5.2.29 TOC Transmission of Digital Message to RAH-66 Stating Rearming Vehicle ETA - The steps in this subparagraph consist of instructions for the transmission and receipt of a message stating the rearming vehicle's ETA.

<u>Step</u>	<u>Operator/System Action</u>	<u>Expected Result</u>	<u>Status</u> (Check One)
4220	At the TOC DMCC, select the Report (RPRT) option from the System Main Menu (SYS MAIN) by clicking on the bezel switch.	The Report (RPRT) Menu is displayed identifying the types of messages which may be sent.	<input checked="" type="checkbox"/> S <input type="checkbox"/> SA <input type="checkbox"/> U
4230	Select the Free Text (FREE TXT) message option by clicking on the bezel switch.	A Free Text message display appears showing the entries which may be made in a Free Text message.	<input checked="" type="checkbox"/> S <input type="checkbox"/> SA <input type="checkbox"/> U
4240	Select the Address (ADRS) of the RAH-66 by clicking on the bezel switch until the entry is highlighted.	The RAH-66 address is highlighted.	<input checked="" type="checkbox"/> S <input type="checkbox"/> SA <input type="checkbox"/> U

4250 Enter the following text in the free text space, using the recorded ETA value:

Rearming vehicle will rendezvous at ES967650 in (ETA) minutes.

The text is displayed as entered.

S SA U

4260 Send the Free Text message by clicking on the Send Routine (SND ROUT) button.

The button is momentarily highlighted.
 •3.2.1.2.2.2.2 (1 RWA, toc)
 See Appendix A, Note 1

S SA U

4270 Click on the CLEAR and RETURN button.

The display returns to the Report (RPRT) Menu.

S SA U

4280 Click on the SYS MAIN button.

The display returns to the System Main Menu (SYS MAIN).

S SA U

4290 At the RAH-66 DMCC, verify the display of an incoming message icon

The incoming message icon disappears.

S SA U

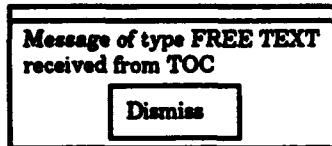

and dismiss the icon by clicking on the Dismiss button.

4300 Select the Message(MSGS) option from the System Main Menu (SYS MAIN) by clicking on the bezel switch.

The Message (MSG) Menu is displayed identifying the messages presently in the message queue. The queue shows 5 messages, 1 urgent Move Command message from the TOC, 1 urgent Free Text Message from the FSE, 2 routine Free Text Messages from the TOC, 1 routine Free Text Messages from the FSE.

S SA U

4310 Select the latest Free Text message received from the TOC by clicking on the PREV/NEXT bezel switches until the entry is highlighted.

The message entry is highlighted.

S SA U

4320 Retrieve and display the Free Text message by clicking on the READ button.

The selected message is displayed.

S SA U

4330 Verify the message contents:
FREE TEXT MESSAGE ROUTINE
SENDER TOC
SENT TO RAH-66
PWD BY
MSG SENT (date/time)
XMIT LCN
XMIT ALT 0 FEET

The message content is as specified.

S SA U

Rearming vehicle will rendezvous at ES967650 in (ETA) minutes.

where date/time is of the format
 26 1745 JUNE 95

4340 Click on the SYS MAIN button.

The display returns to the System Main Menu (SYS MAIN).

S SA U

4350 At the TOC DMCC, verify the display of a Message Acknowledgment

The message acknowledgment disappears.

S SA U

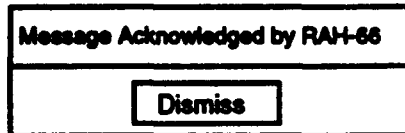

and dismiss the icon by clicking on the Dismiss button.

5.2.30 Fly the RAH-66 Aircraft to Rearming Location and Rearm - The steps in this subparagraph consist of instructions for flying to the rearming location and rearming the RAH-66 aircraft.

Step	Operator/System Action	Expected Result	Status (Check One)
4360	At the RAH-66 softpanel, enter the rearming location grid coordinates (ES967650) and select this waypoint for navigation.	The Situational Display shows the waypoint position relative to the aircraft's current location and heading (represented by the center crosshairs). It also identifies the aircraft's current position, the bearing and range to the waypoint.	<input checked="" type="checkbox"/> S <input type="checkbox"/> SA <input type="checkbox"/> U

4370 Fly towards the rearming location at an altitude of 200 - 250 feet and an airspeed of 80 - 90 knots. When the aircraft reaches the rearming (ES967650) location hover at an altitude of 100 ft.

The aircraft flies to the specified location.

S SA U

4380 When the rearming vehicle (M977) arrives and stops, land the RAH-66 within a 100 meter radius of the vehicle.

The rearming vehicle is visible and stationary.

S SA U

4390 Record the ammunition values

The ammunition values are available from the Instructional Display.

S SA U

Hellfires: 3
Stingers: 0
Hydras: 20
20 mm HEI: 360

and the current time: 3:09

4400 Toggle the Master Weapons Arming Switch from armed to safe.

The weapons arming switches are on safe.

S SA U

4410 Rearm the RAH-66 by monitoring the ammunition levels recording the time when each type's rearming is complete.

The ammunition levels rise until they show a full load.
•3.2.1.1.2.1 (weapons wt.)
•3.2.1.1.2.2 (rearm)

S SA U

Hellfires: 2:42 ^{sec} total time $4 \overline{) 1762} \approx 440 \text{ sec/Hellfire}$
Stingers: 2:40 ^{sec} total time $4 \overline{) 1760} \approx 440 \text{ sec/stinger}$
Hydras: _____
20 mm HEI: _____

FTR-5

4420 Verify each time of transfer against the amount transferred for each ammunition type. Resupply rates are as follows:

Hellfire: 1/40 sec
Stinger: 1/40 sec
Hydra: 19/60 sec
20 mm: 100/60 sec

Record the transfer rates:

Hellfire: _____
Stinger: _____
Hydra: _____
20 mm.: _____

The times of transfer correspond to the amounts transferred.
•3.2.1.1.2.4

S SA U

HYDRAs and 20 mm did not load!

4430 Toggle the Master Weapons Arming Switch from safe to armed.

The weapons arming switches are on armed.

S SA U

4440 At the Admin/Log console note the display of the following messages and dismiss each message by clicking on the Roger button.

The messages are displayed until the Roger button has been clicked.

S SA U

Ammo Truck N is servicing at ES96706500.

Ammo Truck N is no longer servicing at ES96706500.

4450 At the GT System Console, note the display of the following messages. (The messages are repeated for each Stinger loaded.)

The messages are displayed.

S SA U

RWA trying to load 1 Stinger onto (LEFT/RIGHT) WING

RWA saw 1 Stinger loaded onto (LEFT/RIGHT) WING

5.2.31 Test Message Queue - The steps in this subparagraph consist of instructions for filling the message queue to and above required capacity.

Step	Operator/System Action	Expected Result	Status (Check One)		
4460	At the FSE DMCC, use the same message sending procedures to send 12 additional routine messages to the TOC, filling the TCC's message queue (15 messages total).	The TOC message queue reflects the messages sent by the FSE.	<input checked="" type="checkbox"/> S	<input type="checkbox"/> SA	<input type="checkbox"/> U
4470	At the TOC DMCC, verify that the TOC message queue holds the 15 messages.	The message queue holds the 15 messages.	<input checked="" type="checkbox"/> S	<input type="checkbox"/> SA	<input type="checkbox"/> U
4480	Record the first and last entries in the queue: First: <u>1603 U</u> Last: <u>1617 R</u>	The entry information is available from the message queue.	<input checked="" type="checkbox"/> S	<input type="checkbox"/> SA	<input type="checkbox"/> U
4490	At the FSE DMCC, send a 16th message to the TOC.	The 16th message is sent.	<input checked="" type="checkbox"/> S	<input type="checkbox"/> SA	<input type="checkbox"/> U
4500	At the TOC DMCC, verify that only 15 messages are reflected in the message queue, and that the 15 most recent messages are listed. •3.2.1.2.2.1.6 (queue limit) •3.2.1.2.2.1.6.2 (TOC) •3.2.1.2.2.1.6.3 (TOC)	The 15 most recent messages are listed.	<input checked="" type="checkbox"/> S	<input type="checkbox"/> SA	<input type="checkbox"/> U
4510	At the TOC DMCC, use the same message sending procedures to send 11 additional messages to the FSE, filling the FSE's message queue (15 messages total).	The FSE message queue reflects the messages sent by the TOC.	<input checked="" type="checkbox"/> S	<input type="checkbox"/> SA	<input type="checkbox"/> U
4520	At the FSE DMCC, verify that the FSE message queue holds the 15 messages.	The message queue holds the 15 messages.	<input checked="" type="checkbox"/> S	<input type="checkbox"/> SA	<input type="checkbox"/> U
4530	Record the first and last entries in the queue: First: <u>1639 R</u> Last: <u>1608 R</u>	The entry information is available from the message queue.	<input checked="" type="checkbox"/> S	<input type="checkbox"/> SA	<input type="checkbox"/> U
4540	At the TOC DMCC, send a 16th message to the FSE.	The 16th message is sent. most recent messages.	<input checked="" type="checkbox"/> S	<input type="checkbox"/> SA	<input type="checkbox"/> U

4550 At the FSE DMCC, verify that only 15 messages are reflected in the message queue, and that the 15 most recent messages are listed.

The 15 most recent messages are listed.
 *3.2.1.2.2.1.6.2 (FSE)
 *3.2.1.2.2.1.6.3 (FSE)

S SA U

5.2.32 Terminate the Exercise - The steps in this subparagraph consist of instructions for terminating the exercise.

Step	Operator/System Action	Expected Result	Status (Check One)
4560	At the SIMNET SCC, select the Battlemaster Functions Option and GO to the next menu.	A display appears requesting the Battlemaster password.	<input checked="" type="checkbox"/> S <input type="checkbox"/> SA <input type="checkbox"/> U
4570	Enter the Battlemaster password (foozball) and click on the OK button.	The Battlemaster Overview menu is displayed showing the following selectable options: Displacement Reconstitution Gunnery Targets Resume Initialization End Exercise	<input checked="" type="checkbox"/> S <input type="checkbox"/> SA <input type="checkbox"/> U
4580	Select the End Exercise option and GO to the next menu.	An End Exercise Confirmation Menu is displayed.	<input checked="" type="checkbox"/> S <input type="checkbox"/> SA <input type="checkbox"/> U
4590	Respond to the Confirmation Question by clicking on YES.	The Confirmation Display disappears and the display returns to the Mac windows display. The Admin./Log Console display returns to the Mac windows display. *3.2.1.1.3.2 (Mac shutdown, Init State)	<input checked="" type="checkbox"/> S <input type="checkbox"/> SA <input type="checkbox"/> U
4600	At the AIRNET SCC, select the Battlemaster Functions Option and Go to the next menu.	A display appears requesting the Battlemaster password.	<input checked="" type="checkbox"/> S <input type="checkbox"/> SA <input type="checkbox"/> U
4610	Enter the Battlemaster password (foozball) and click on the Ok button.	The Battlemaster Overview menu is displayed showing the following selectable options: Displacement Reconstitute Gunnery Targets Resume Initialization End Exercise	<input checked="" type="checkbox"/> S <input type="checkbox"/> SA <input type="checkbox"/> U
4620	Select the End Exercise option and Go to the next menu.	An End Exercise confirmation menu is displayed.	<input checked="" type="checkbox"/> S <input type="checkbox"/> SA <input type="checkbox"/> U

4630 Respond to the Confirmation Question by clicking on YES.

The Confirmation Display disappears and the display returns to the Macintosh windows screen. The CIG system console displays the message "Deactivating from MCC" and sound and visuals are terminated.

S SA U

- 3.2.1.1.3.1
- 3.2.1.1.3.2
- 3.2.1.2.3
- 3.2.1.2.4
- 3.2.1.2.4.1

6.0 NOTES

Test failures will be noted in the procedure against each test step as necessary where test results do not agree with expected results. Due to the nature of these system level tests, a simulator "crash" due to pilot error will not be constituted as a failure but an acceptable interruption. The system provides the capability for re-starting at the point of where the crash occurred and will be utilized during the execution of this system level test.

7.0 Test Failures/Interruptions

NOTE ANY FAILURES ENCOUNTERED DURING THE TEST IN THIS SECTION.

NO.	FAILURE/INTERRUPTION DESCRIPTION

8.0 Glossary

Admin./Loy	Administration/Logistics
ADRS	Address
AIRNET	Aircraft Simulation Network
ALOC	Administration/Logistics Operations Console
Ammo	Ammunition
BBN	Bolt, Beranek, and Newman
CEOI	Communications and Electronics Operations Instructions
CG	Computer Image Generator
CPG	Co-Pilot/Gunner
DMCC	Digital Message Communications Console
DMS	Digital Message Server
ETA	Estimated Time of Arrival
FRED	Fully Reconfigurable Device
FREE TXT	Free Text
FSE	Fire Support Element
FWD	Forward
GT-111	BBN Computer System/CIG supporting Simulation
HEI	High Explosive Incendiary
HUMMV	High Mobility Multi-Wheeled Vehicle
I & T	Integration & Test
IMMED	Immediately
lbs.	pounds
LCTN	Location
Mac	Macintosh Computer
MCC	Management, Command and Control Console
MIPS	AIRNET MCC Host Computer
MOV TO	Move To
MOV CMD	Move Command
MSG	Message
MSGS	Messages
MTO	Movement to Order
PDU	Protocol Data Unit
PIE	Pyrotechnic Incendiary Explosive
RAH-66	Comanche Helicopter
RECON	Reconnaissance
RECON TYPE	Reconnaissance Type
REQT	Request
RPRT	Report
RWA	Rotary Wing Aircraft
S/W	Software
SCC	System Control Console
SDF	System Development Facility, Loral WDL, San Jose
SIMNET	Simulation Network
SND ROUT	Send Routine
SND URG	Send Urgent
SYS MAIN	System Main Menu
TCC	Tactical Operations Center
UMCP	Unit Maintenance Collection Point
UTM	Universal Transverse Mercator
WDL	Western Development Labs

WHN RDY
XMIT ALT
XMIT LCN

When Ready
Transmit Altitude
Transmit Location

APPENDIX A

EXERCISE "A" REQUIREMENTS MATRIX

The following tables are referenced below.

Table 3.2.1.1 - 1

Weapons System	Weapon Quantity	Weapon Weight	Notes:
Hellfire	14*	101 lbs. ea.	
Stinger	18*	22.6 lbs. ea.	
Rocket	62*	20.6 lbs. ea.	all 2.75 in rockets
20 mm ammo	500 rounds	112 lbs. total	PIE or HEI

* For a reconnaissance mission 4 Hellfire may be configured with 2 Stinger. When configuring a maximum missile load the weapon quantities are exclusive of each other.

Table 3.2.1.1 - 2

Configuration	Weight
Max self deployed	17,174 lbs.
Primary mission	10,112 lbs.
Empty	7500 lbs.
Useful load	2612 lbs.
Internal fuel	1820 lbs. (280 gals.)
Self deploy	7670 lbs. (1180 gals.)

REQ NO.	TITLE	REQUIREMENT
3.2.1.1.1.1	Terrain Data Base Definition	The MCC shall specify the terrain database (name and area) to be used by the RAH-66 Comanche simulator.
3.2.1.1.1.2	Simulator Identifier	The MCC shall specify the simulator vehicle identifier to be utilized by the RAH-66 Comanche simulator.
3.2.1.1.1.3	Simulator Placement	The MCC shall specify the location and heading (placement) to be utilized by the RAH-66 Comanche simulator.
3.2.1.1.1.4	Weapons Load	The MCC shall support the definition of the weapons load for the RAH-66 Comanche simulator.
3.2.1.1.1.5	Weapons Weight and Quantity	The MCC shall impose weight and quantity constraints in accordance with table 3.2.1.1.-1 given below
3.2.1.1.1.6	Default Weapons Load	The MCC shall maintain a default weapons load which to be used in the event that the weapons load is not explicitly selected.
3.2.1.1.1.7	Fueling	The MCC shall support the fueling of the RAH-66 Comanche simulator.
3.2.1.1.1.8	Fuel Load Constraint	The MCC shall impose a weight limit on the allowable fuel load in accordance with table 3.2.1.1.-2.

REQ NO.	TITLE	REQUIREMENT
3.2.1.1.1.9	Default Fuel Load Constraint	The MCC shall maintain a default fuel load which shall be used in the event that the fuel load is not explicitly selected.
3.2.1.1.1.10 See Notes (1)	RAH-66 Configuration	The MCC shall allow the configuration of one to eight RAH-66 Comanche simulators engaged in simulated reconnaissance, tactical maneuver, or battle exercises.
3.2.1.1.1.11 See Notes (2)	Configuration Parameters	The MCC shall specify the configuration parameters for the RAH-66 Comanche simulator to include but not be limited to the following:
3.2.1.1.2.1	Rearmament	The MCC shall rearm the RAH-66 Comanche simulator based on current weapons status and weapons load constraints contained in table 3.2.1.1-1.
3.2.1.1.2.2	Resupply Vehicles	The MCC shall use the same armament resupply vehicles for the RAH-66 rearmament as those used for already existing and selectable on the MCC.
3.2.1.1.2.3	Weapons Load Request	The RAH-66 Comanche simulator shall inform the MCC about the current status of weapons load upon request.
3.2.1.1.2.4	Rearm Time	The time of transfer of weapons shall be simulated by the MCC.
3.2.1.1.2.5	Refueling	The MCC shall refuel the RAH-66 Comanche simulator based on current fuel status and fuel load constraints contained in table 3.2.1.1-2.
3.2.1.1.2.6	Refueling Vehicles	The MCC shall use the same armament refueling vehicles for the RAH-66 refueling as those used for ground-based simulators.
3.2.1.1.2.7	Current Fuel Status	The RAH-66 Comanche simulator shall inform the MCC of the current status of fuel remaining in the vehicle upon request.
3.2.1.1.2.8	Fuel transfer Time	The time of transfer of fuel shall be simulated by the MCC.
3.2.1.1.2.10	Placement Upon Activation	Upon activation the simulator shall appear on the terrain database at the site of the 8 digit coordinates entered in the location entry on the SCC console.
3.2.1.1.2.11	Default Heading	The MCC shall default the heading to 0 degrees (Topographic North) should the heading entry be blank at the time of activation
3.2.1.1.3.1	Terminate Exercise	The MCC shall perform the termination of an exercise.
3.2.1.1.3.2	Termination Functions	The MCC shall perform the following during termination of an exercise: <ul style="list-style-type: none"> • Send Deactivation Requests to all simulators • Shutdown all Mac Consoles • Begin initialization state

REQ NO.	TITLE	REQUIREMENT
3.2.1.2.2.1.2	TOC Station Notification	The Computer Digital Message function shall notify the Tactical Operations Center (TOC) of an incoming message and place message contents in the TOC storage queue.
3.2.1.2.2.1.3	FSE Station Notification	The Computer Digital Message function shall notify the Fire Support Element (FSE) of an incoming message and place message contents in the FSE storage queue.
3.2.1.2.2.1.4	TOC Operator Notification of Message Receipt	The TOC station shall display an incoming message icon upon message notification from the MCC host.
3.2.1.2.2.1.5	FSE Operator Notification of Message Receipt	The FSE station shall display an incoming message icon upon message notification from the MCC host.
3.2.1.2.2.1.6	Message Storage	Messages will be automatically stored until either deleted by a station operator or until the maximum message storage limits have been attained.
3.2.1.2.2.1.6.1	Message Queuing	Messages shall be automatically queued upon receipt for either the FSE and/or the TOC.
3.2.1.2.2.1.6.2	Message Quantity	The MCC system shall store a maximum of 15 messages each for the FSE and TOC.
3.2.1.2.2.1.6.3	Most Recent Messages	Only the most recent messages each shall be stored for either the FSE or TOC stations.
3.2.1.2.2.1.6.4	Message Type	Message types received shall consist of either pre formatted text or free text messages.
3.2.1.2.2.2.1 See Note (1)	Pre Formatted Text Messages	The TOC or FSE shall be capable of sending pre formatted messages to the RAH-66 Comanche player(s). A pre formatted message is any previously defined message file.
3.2.1.2.2.2.2 See Note (1)	Free Text Messages	The TOC or FSE shall be capable of sending free text messages to the RAH-66 Comanche player(s). A free text message is any message entered by the station operator within the Access Mode.
3.2.1.2.2.2.3	Sending Messages	The TOC and FSE shall allow a message to be sent, deleted, retrieved for viewing, forwarded, acknowledged and replied to.
3.2.1.2.2.3.1.1	Retrieve Selected Message	The station operator shall be able to select any message for retrieval and display from the station's storage queue.
3.2.1.2.2.3.1.2 See Note (3)	Retrieve Function Transition	The operator shall be able to transition to Access Mode, Reply, Forward, Acknowledge and Delete from within the Retrieve function.
3.2.1.2.2.3.2.a	Message Reply Function	The reply function shall automatically send preformatted or freehand messages to the RWA player whose message has been selected.
3.2.1.2.2.3.2.b	Message Reply Function	The operator shall be able to select Access Mode and the Delete function from within the Reply function.

REQ NO.	TITLE	REQUIREMENT
3.2.1.2.2.3.2.1	Reply to Selected Message	The reply function allows the station operator to send a reply to the originator of the selected message from the storage queue.
3.2.1.2.2.3.2.2	Reply Function Message Type	The operator shall be able to reply to a selected message by either sending a freehand (typed) or a preformatted text message.
3.2.1.2.2.3.2.3	Reply Function Transition	The operator shall transition to Access Mode and the Delete function from within the Reply function.
3.2.1.2.2.3.3	Message Forward Function	The forward function shall allow the selected message to be forwarded to the RWA player or MCC Station. Preformatted or freehand messages can be included.
3.2.1.2.2.3.3.1	Forward Selected Message	The forward function allows the station operator to forward the selected message from the storage queue to another MCC station or RWA player.
3.2.1.2.2.3.3.2	Forward Function Message Type	The operator shall be able to forward the selected message and include either a freehand (typed) or a preformatted text message if desired.
3.2.1.2.2.3.3.3	Forward Function Transition	The operator shall transition to Access Mode and the Delete function from within the Forward function.
3.2.1.2.2.3.3.4	Select Access or Delete Function	The operator shall be able to select Access mode and the Delete function from within the Forward function.
3.2.1.2.2.3.4	Acknowledge Selected Message	Only one Acknowledgment shall be sent for any message in the storage queue.
3.2.1.2.2.3.4.1	Acknowledge Selected Message	The acknowledge function shall automatically acknowledges the selected message from the storage queue.
3.2.1.2.2.3.4.2	Acknowledge function message type	A preformatted text message will automatically be sent to the message originator acknowledging message receipt and display at the receiving station.
3.2.1.2.2.3.4.3	Acknowledge Function Transition	The acknowledge function shall automatically transition to the retrieve function and display the selected message unless the message has already been retrieved (displayed).
3.2.1.2.2.3.4.3.a See Note (3)	Acknowledge Function Transition	If the message has already been displayed, the operator shall transition to Access Mode, Retrieve or Delete functions.
3.2.1.2.2.3.5.1	Message Deletion	The station operator shall be able to delete messages from the station's storage queue.
3.2.1.2.2.3.5.2	Delete Function Transition	The Delete function shall return automatically to Access Mode.
3.2.1.2.2.3.6	Send (originate) a Message	The send function shall allow the station operator to originate and send preformatted or freehand text messages to an RWA player or another MCC station.
3.2.1.2.2.3.6.1	Send Message	The send function allows the station operator to originate a message and send to another MCC station or to an RWA player.
3.2.1.2.2.3.6.2	Send Function Message Type	The operator shall be able to send either a freehand (typed) or a preformatted text message.

REQ NO.	TITLE	REQUIREMENT
3.2.1.2.2.3.6.3	Send Function Transition	The operator shall be able to select Access Mode, Forward, or Delete function from within the Send function.
3.2.1.2.3	Segment capability relationships	Management Command and Control capability relationships are not affected by modifications except as described by the Digital Message/Communications capabilities.
3.2.1.2.4.	Segment External Interface Requirements.	All external interfaces shall remain SIMNET 6.6.1 compliant.
3.2.1.2.4.1	MCC Digital Message/Comm. Upgrades External Interface Description	The external interface for the MCC Digital Message/Communication Upgrade shall be compliant with SIMNET 6.6.1.

ATAC II Requirements

3.2.1	ATAS Symbology	The RWA software shall be modified to display an ATAS reticle model in the Out-the-Window (OTW) views when the ATAS missile is selected.
3.2.2.1	ATAS Symbology	The ATAS reticle shall consist solely of a square "lock-on" reticle.
3.2.2.2	ATAS Symbology	The ATAS reticle shall exhibit screen dimension ratios equivalent to that of the 2d overlay sensor version: horizontal extents occupying - 10% of the horizontal screen space, vertical extents occupying - 13% of the vertical screen space.
3.2.2.3	ATAS Symbology	The ATAS reticle shall be emulated as a 3d model in the Dynamic Elements Database (DED).
3.2.3	ATAS Symbology	The RWA software shall use the existing ATAS lock-on cone dimensions, i.e. +/- 10 degrees.
3.2.8	ATAS Symbology	The RWA software shall use the existing weapons switchology algorithms.
3.2.9	ATAS Symbology	The 3d ATAS reticle shall be displayed on the OTW visuals only.
3.2.10.1	ATAS Symbology	The RWA DEDs shall be modified to contain a "normal" version of the ATAS reticle in the OTW DED for use in locking on to targets within a range of 3.5 km. or less.
3.2.10.2	ATAS Symbology	The RWA DEDs shall be modified to contain a "modified" version of the ATAS reticle in the OTW DED for use in locking on to targets beyond the OTW 3.5 km. visual range. (Note: The current design concept for the modified reticle is to have it contain a "black dot" in the center to signify that it is locked onto a target.)

REQ NO.	TITLE	REQUIREMENT
3.2.10.3	ATAS Symbology	The RWA DEDs shall be modified to contain a "null" (invisible) version of the ATAS reticle in the Daylight Television (DTV) / Thermal DED. (Note: The null version for the DTV/Thermal DED is required in order to avoid having the sensor inadvertently display the pilots 3d reticle model.)
3.2.11.1	ATAS Symbology	The 2d ATAS reticle to be displayed in the sensor channel shall consist of two dashed concentric squares centered on the sensor line of sight when the ATAS missile has been selected, but is not seeking. Neither the aural seek tone nor the aural lock-on tone will be generated.
3.2.11.2	ATAS Symbology	The 2d ATAS reticle to be displayed in the sensor channel shall consist of two dashed concentric squares centered on the sensor line of sight when the ATAS missile is actively seeking. The aural seek tone will be generated.
3.2.11.3	ATAS Symbology	The 2d ATAS reticle to be displayed in the sensor channel shall consist of two solid concentric squares centered on the target coordinates when the ATAS missile is tracking a target. The aural lock-on tone will be generated.
3.2.12	ATAS Symbology	The ATAS reticles (2d in the sensor channel and 3d in the OTW visuals) shall be displayed when either the pilot or copilot/gunner (CPG) selects the ATAS missile.
3.3.1.5	Manned Rotary Wing Aircraft	A Missile Server shall not be required for autonomous Hellfire designation (as in the current implementation) functionality to exist. If no Missile Server is present, the Hellfire works as in the current implementation.
3.3.1.10	Manned Rotary Wing Aircraft	The SAD menu shall be modified to allow a target UTM grid coordinate to be manually entered as the Hellfire destination point.
3.3.1.11	Manned Rotary Wing Aircraft	The RWA shall incorporate a random offset, forward of the target UTM grid coordinate, as the destination point which the Hellfire will fly toward.
3.3.1.13 See Note (4)	Manned Rotary Wing Aircraft	The Hellfire impact point shall be determined by the laser designation point, whether local (autonomous fire) or remote.
3.3.1.14	Manned Rotary Wing Aircraft	Automatic range determination shall be displayed as a four digit integer number on the sensor display, as in the current implementation.
3.3.1.15	Manned Rotary Wing Aircraft	Ranges calculated from target UTM grid coordinates shall be displayed in the format NXXXX where XXXX is the range to the coordinate in meters.

REQ NO.	TITLE	REQUIREMENT
3.3.1.17	Manned Rotary Wing Aircraft	The modes of the Hellfire missiles (primary/secondary) and trajectories (LOBL, LOAL direct, LOAL high, LOAL low) shall be implemented only to the extent that they have been implemented in the current version of the RWA.
3.3.1.18	Manned Rotary Wing Aircraft	The laser rangefinder/designator symbology shall be displayed in the upper left corner of the sensor display.
3.3.1.19	Manned Rotary Wing Aircraft	The laser rangefinder mode symbology shall consist of the phrase "RNG".
3.3.1.21	Manned Rotary Wing Aircraft	The laser status symbology OFF/SAFE/ARM shall be displayed in the upper left corner of the sensor display, beneath the rangefinder/designator symbology.
3.3.1.25	Manned Rotary Wing Aircraft	The RWA Hellfire switchology shall remain as it is in the current implementation.
3.3.1.26.1	Manned Rotary Wing Aircraft	The RWA Hellfire constraint symbology shall consist of a solid "in constraint" square (as in the current implementation).
3.3.1.26.2	Manned Rotary Wing Aircraft	The RWA Hellfire constraint symbology shall consist of a dashed "out of constraint" square, the same size and shape as the "in constraint" version.
3.3.1.27	Manned Rotary Wing Aircraft	The RWA Hellfire constraint limits shall remain as they are in the current implementation, i.e., +/- 20 degrees.
3.3.1.30.2	Manned Rotary Wing Aircraft	The following shall be modifiable at any time the RWA is in an active state of simulation: Hellfire target UTM grid coordinates.

Notes:

- (1) This requirement is satisfied for a single RAH-66 Comanche player. The procedures verifying this requirement for multiple players may be found in Exercise "C".
- (2) This requirement is satisfied for all items listed, with the exception of Airframe Time. Refer to AIRNET Inspection/Analysis Report 3 for information related to satisfaction of the airframe portion of this requirement.
- (3) Access Mode is defined as the Message Queue display, and is equivalent to Retrieve.
- (4) This requirement is satisfied for local (autonomous) fire only. The procedures verifying this requirement for remote fire may be found in Exercise "C".

Appendix B

Exercise "A" Requirements Inspection/Analysis Matrix

REQ NO.	TITLE	REQUIREMENT	Report Reference
3.2.1.2.1.1	No Message Processing Required	The MCC Digital Message / Communications function shall operate in a standby state on the MCC system when message processing is not required.	1
3.2.1.2.1.2	Transition to Active State - Operator Request	The MCC Digital Message / Communications function shall transition to the active state upon receipt of an MCC operator request.	1
3.2.1.2.1.3	Transition to Active State - PDU Receipt	The MCC Digital Message / Communications function shall transition to the active state upon receipt of an digital message PDU by the MCC.	1
3.2.1.2.1.4	Transition to Standby State	The MCC Digital Message / Communications function shall transition to the standby state when there is no activity in any of the three active state modes - receive, send and access.	1
3.2.1.2.2.1.1	Activation Upon PDU Receipt	The Receive Mode shall be activated upon receipt of a digital message PDU by the MCC host.	1
3.9.1	MCC Comanche Support Upgrade Segment Qualification	The MCC Comanche Support Upgrade Segment shall be qualification tested at Ft. Rucker.	2
3.9.1.a	MCC Comanche Support Upgrade Segment Qualification	The MCC Comanche Support Upgrade test shall take place during the program integration and test phase (I&T).	2
3.9.1.b	MCC Comanche Support Upgrade Segment Qualification	The MCC Comanche Support Upgrade test shall not exceed 2 working days.	2
3.9.1.c	MCC Comanche Support Upgrade Segment Qualification	The testing shall demonstrate the MCC Comanche Support Upgrade provides the functionality described previously in this document.	2

REQ NO.	TITLE	REQUIREMENT	Report Reference
3.9.2	MCC Digital Message / Communications Segment Qualification	The MCC Digital Message / Communications Segment shall be qualification tested at Ft. Rucker.	2
3.9.2.a	MCC Digital Message / Communications Segment Qualification	The MCC Digital Message / Communications Segment test shall take place during the program integration and test phase (I&T).	2
3.9.2.b	MCC Digital Message / Communications Segment Qualification	The MCC Digital Message / Communications Segment test shall not exceed 1 working day.	2
3.9.2.c	MCC Digital Message / Communications Segment Qualification	The testing shall demonstrate the MCC Digital Message / Communications Segment provides the functionality described previously, in this document.	2

ATAC II Requirements

3.1.1	General	Modifications to "RWA" functionality and capabilities shall be made solely to the manned vehicle Generic Rotary Wing Aircraft simulator unless stated otherwise.	4
3.1.2	General	ATAC software shall not be required to communicate via the DIS protocol.	4
3.1.3	General	Network communications shall be made using the current implementation of the SIMNET protocol.	4
3.1.4	General	Where necessary, extensions to the SIMNET protocol shall be allowed.	4
3.1.5	General	All software modifications will be made according to the guidelines and practices of the Kernighan and Ritchie "C" (K & R C) programming language.	4
3.2.4	ATAS Symbology	The RWA software shall use the existing ATAS lock-on algorithms for determining which types of entities it can lock on to.	5
3.2.5	ATAS Symbology	The RWA software shall use the existing ATAS intervisibility algorithms.	5
3.2.6	ATAS Symbology	The RWA software shall use the existing ATAS maximum lock-on range of 7.0 km.	5

REQ NO.	TITLE	REQUIREMENT	Report Reference
3.2.7	ATAS Symbology	The RWA software OTW maximum visual range of 3.5 km. shall remain as its is in the current software.	5
3.2.13	ATAS Symbology	The ATAS reticles shall be displayed for all missiles of type "target_guided" as defined in the RWA data file "reconfig.rwa".	5
3.2.14	ATAS Symbology	The ATAS reticles shall be displayed for any configuration of the RWA which has selected a "target_guided" missile type.	5
3.3.1.12	Manned Rotary Wing Aircraft	The Hellfire range (calculated from the target UTM grid coordinate or from the laser autorangefinder) shall determine the initial value for the Time of Flight (TOF) overlay on the sensor display.	6

Appendix C

Exercise "A" Inspection/Analysis Reports

Report Reference

1. MCC Digital Message Communications Console Requirements
2. MCC Comanche Support and Digital Message Communications Console Qualification Requirements
3. MCC Comanche Configuration Parameters Requirement - Airframe Time
4. ATAC II General Requirements
5. ATAC II ATAS Requirements
6. ATAC II Hellfire Requirements

AIRNET INSPECTION/ANALYSIS REPORT 1

Req. No.: 3.2.1.2.1.1	Spec. Para.: 3.2.1.2.1.1
3.2.1.2.1.2	3.2.1.2.1.2
3.2.1.2.1.3	3.2.1.2.1.3
3.2.1.2.1.4	3.2.1.2.1.4
3.2.1.2.2.1.1	3.2.1.2.2.1.1

Requirement Descriptions:**Req. No.: 3.2.1.2.1.1 No Message Processing Required**

The MCC Digital Message/Communications function shall operate in a standby state on the MCC system when message processing is not required.

Req. No.: 3.2.1.2.1.2 Transition to Active State - Operator Request

The MCC Digital Message/Communications function shall transition to the active state upon receipt of an MCC operator request.

Req. No.: 3.2.1.2.1.3 Transition to Active State - PDU Receipt

The MCC Digital Message/Communications function shall transition to the active state upon receipt of a digital message PDU by the MCC.

Req. No.: 3.2.1.2.1.4 Transition to Standby State

The MCC Digital Message/Communications function shall transition to the standby state when there is no activity in any of the three active state modes - receive, send and access.

Req. No.: 3.2.1.2.2.1.1 Activation Upon PDU Receipt

The Receive Mode shall be activated upon receipt of a digital message PDU by the MCC host.

Inspection Method: As designed, the MCC Digital Message/Communications function executes independently from the AIRNET MIPS-based MCC system. It resides on a SUN workstation, linked to the MIPS-based MCC via the SIMNET Ethernet network (Fig. 1 - 1). This platform provides the functionality for all DMCC consoles and message/communications processing.

The DMCC function operates in a standby state when message/communications functions are not required (3.2.1.2.1.1). When a message is received, either from a console user (Operator Request, 3.2.1.2.1.2) or from the Ethernet network (Digital Message PDU, 3.2.1.2.1.3), the function transitions to an active state to perform the necessary message/communications processing. When there is no activity (send, receive, operator access), the function again transitions to its standby state (3.2.1.2.1.4). The receive mode is activated by the Digital Message/Communications function within the SUN workstation platform, independent of the MCC host, upon receipt of a digital message PDU via the SIMNET Ethernet network (3.2.1.2.2.1.1).

The implemented system, in conjunction with the DMCC operations demonstrated during the Exercise "A" test, can be inspected to comply with the above listed requirements and Fig. 1 - 1.

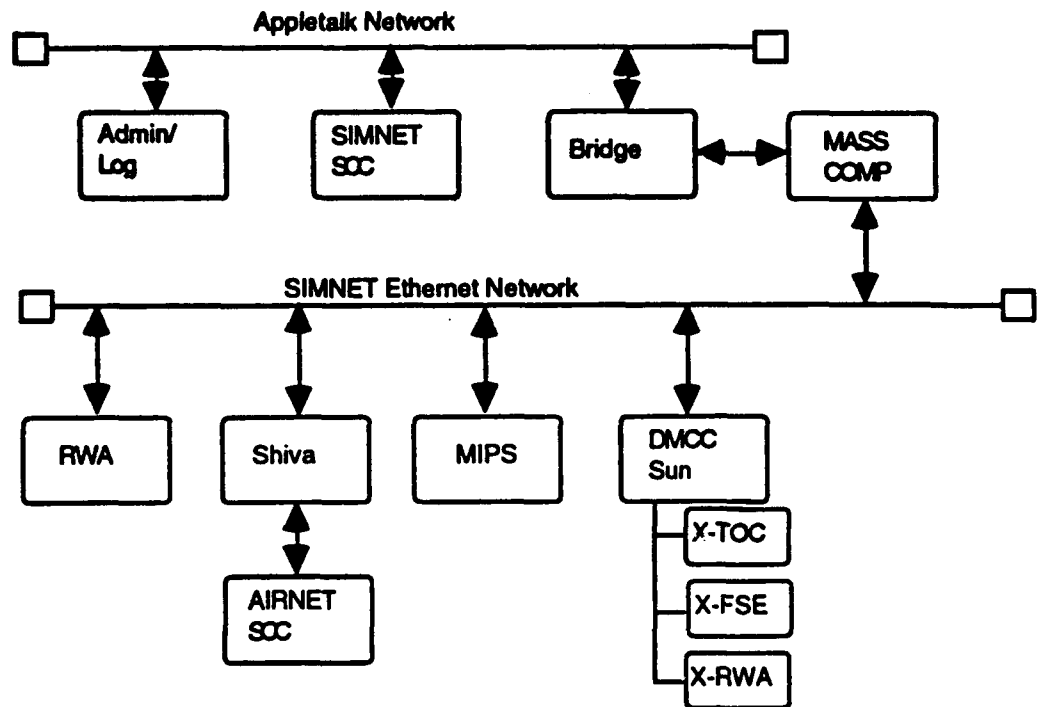

Figure 1 - 1 AIRNET Functional Configuration

VERIFIED: _____

TITLE: _____

CONCURRENCE: _____

AIRNET INSPECTION/ANALYSIS REPORT 2

Req. No.:	3.9.1	Spec. Para.:	3.9.1
	3.9.1.a		3.9.1
	3.9.1.b		3.9.1
	3.9.1.c		3.9.1
	3.9.2		3.9.2
	3.9.2.a		3.9.2
	3.9.2.b		3.9.2
	3.9.2.c		3.9.2

Requirement Descriptions:

Req. No.: 3.9.1 MCC Comanche Support Upgrade Segment Qualification
The MCC Comanche Support Upgrade Segment shall be qualification tested at Ft. Rucker.

Req. No.: 3.9.1.a MCC Comanche Support Upgrade Segment Qualification
The MCC Comanche Support Upgrade test shall take place during the program integration and test phase (I&T).

Req. No.: 3.9.1.b MCC Comanche Support Upgrade Segment Qualification
The MCC Comanche Support Upgrade test shall not exceed 2 working days.

Req. No.: 3.9.1.c MCC Comanche Support Upgrade Segment Qualification
The testing shall demonstrate the MCC Comanche Support Upgrade provides the functionality described previously in this document.

Req. No.: 3.9.2 MCC Digital Message/Communications Segment Qualification
The MCC Digital Message/Communications Segment shall be qualification tested at Ft. Rucker.

Req. No.: 3.9.2.a MCC Digital Message/Communications Segment Qualification
The MCC Digital Message/Communications Segment test shall take place during the program integration and test phase (I&T).

Req. No.: 3.9.2.b MCC Digital Message/Communications Segment Qualification
The MCC Digital Message/Communications Segment test shall not exceed 1 working day.

Req. No.: 3.9.2.c MCC Digital Message/Communications Segment Qualification
The testing shall demonstrate the MCC Digital Message/Communications Segment provides the functionality described previously in this document.

Inspection Method: The test procedures for Scenario A can be inspected to verify compliance with the requirements listed above.

VERIFIED: _____

TITLE: _____

CONCURRENCE: _____

AIRNET INSPECTION/ANALYSIS REPORT 3

Req. No.: 3.2.1.1.1.11

Spec. Para.: 3.2.1.1.1.11

Requirement Descriptions:

Req. No.: 3.2.1.1.1.11 Configuration Parameters

The MCC shall specify the configuration parameters for the RAH-66 Comanche simulator to include but not be limited to the following:

- a. Tail Number
- b. Airframe Time
- c. Maintenance Status
- d. Fuel Load
- e. Weapons Load
 1. Missiles
 2. Rockets (HYDRA)
 3. Guns

Inspection Method: The test procedure provides verification of all required fields with the exception of the airframe time. The AIRNET MCC System Control Console's (SCC) user interface makes use of data files which define the contents of the various window displays. Among the displays is one which allows customization of the aircraft. It appears as shown below.

Simulator: 8B	Tail No.	1
Simulator type: FRED	Location	
Assigned to: A Company	Heading	(Deg)
Vehicle type: AH-64	Maint. Status:	• - New
Alignment: US		

Fuel Load	
30 mm single barrel	
Hellfire missiles	
Stinger missiles	
Hydra 70 10lb	
Hydra 70 MPSM	
Hydra 70 Flechette	

Set Value to: Default Custom

Cancel Activate

This window makes use of the contents of simmodels.lisp. This file contains the vehicle characteristics for each vehicle type including the RAH-66 Comanche. Shown below are portions of

simmodels.lisp which support the generation of the previously shown menu. The first entry is for the AH-64, the second for the RAH-66 Comanche. Note that comments begin with ;:

The entries are nearly identical; the AH-64 entry contains a reference to airframe time. Note that this reference is commented out and not used in the displayed menu. Thus the menu displays for the two aircraft would be identical. Should it later be desirable to include the airframe time in the menu display, the airframe time could be added to the RAH-66 entry.

(fields

(AH64_FIELDS

(bumper 1 ACT_INTEGER "Tail No." (ACT_MINMAX 1 99) "" "")

(location 1 ACT_MAPCOORD "Location" () "" "")

(hull_az 1 ACT_INTEGER "Heading" (ACT_MINMAX 0 360) "(Deg)" "0")

(fuel 2 ACT_FLOAT "Fuel Load" (ACT_MINMAX 0 2438) "Lbs" "2438")

:: (airframe 2 ACT_INTEGER "Airframe time" (ACT_MINMAX 0 5000) "Hours" "164")

(munition__30mm_bullet 2 ACT_INTEGER "30mm single barrel"
(ACT_MINMAX 0 1200) "Rounds" "1200")

(munition__hellfire 2 ACT_INTEGER "Hellfire missiles"
(ACT_MINMAX 0 16) "" "8")

(munition__stinger 2 ACT_INTEGER "Stinger missiles" (ACT_MINMAX 0 4) "" "4")

(munition__hydra_10lb 2 ACT_INTEGER "Hydra 70 10lb"
(ACT_MINMAX 0 76) "" "38")

(munition__hydra_mpsm 2 ACT_INTEGER "Hydra 70 MPSM"
(ACT_MINMAX 0 76) "" "0")

(munition__hydra_flech 2 ACT_INTEGER "Hydra 70 Flechette"
(ACT_MINMAX 0 76) "" "0"))

(RAH66_FIELDS

(bumper 1 ACT_INTEGER "Tail No." (ACT_MINMAX 1 99) "" "")

(location 1 ACT_MAPCOORD "Location" () "" "")

(hull_az 1 ACT_INTEGER "Heading" (ACT_MINMAX 0 360) "(Deg)" "0")

(fuel 2 ACT_FLOAT "Fuel Load" (ACT_MINMAX 0 2438) "Lbs" "2438")

(munition__20mm_hei 2 ACT_INTEGER "20mm HEI"
(ACT_MINMAX 0 1200) "Rounds" "1200")

(munition__20mm_pie 2 ACT_INTEGER "20mm PIE"
(ACT_MINMAX 0 1200) "Rounds" "0")

(munition__hellfire 2 ACT_INTEGER "Hellfire missiles"
(ACT_MINMAX 0 14) "" "8")

(munition__stinger 2 ACT_INTEGER "Stinger missiles" (ACT_MINMAX 0 18) "" "4")

(munition__hydra_10lb 2 ACT_INTEGER "Hydra 70 10lb"
(ACT_MINMAX 0 62) "" "38")

(munition__chaff 2 ACT_INTEGER "Chaff"
(ACT_MINMAX 0 4) "" "0")

(munition__flares 2 ACT_INTEGER "Flares"
(ACT_MINMAX 0 8) "" "0")

)

)

The referenced data file can be reviewed and inspected for validation of this requirement.

VERIFIED: _____

TITLE: _____

CONCURRENCE: _____

AIRNET INSPECTION/ANALYSIS REPORT 4

Req. No.:	ATAC I: 3.1.1	Spec. Para.:	3.1
	ATAC II 3.1.2		3.1
	ATAC II 3.1.3		3.1
	ATAC II 3.1.4		3.1
	ATAC II 3.1.5		3.1

Requirement Descriptions:

Req. No.: ATAC II 3.1.1 General

Modifications to "RWA" functionality and capabilities shall be made solely to the manned vehicle Generic Rotary Wing Aircraft simulator unless stated otherwise.

Req. No.: ATAC II 3.1.2 General

ATAC software shall not be required to communicate via DIS protocol.

Req. No.: ATAC II 3.1.3 General

Network communications shall be made using the current implementation of the SIMNET protocol.

Req. No.: ATAC II 3.1.4 General

Where necessary, extensions to the SIMNET protocol shall be allowed.

Req. No.: ATAC II 3.1.5 General

All software modifications will be made according to the guidelines and practices of the Kernighan and Ritchie "C" (K & R C) programming language.

Inspection Method: The modifications to "RWA" functionality and capabilities are limited to those changes made to the RWA executable; no changes were made to the real time software executable (rttgr5.7) which runs in concert with the RWA vehicle executable. All modifications have been made according to the guidelines and practices of the K & R "C" programming language. Each of the test scenarios, A, B and C utilizes the existing real time executable and the new RWA executable.

The RWA executable utilizes the original SIMNET protocol software libraries with extensions for Protocol Data Units (PDUs) which allow remote designation. The software function rwa_desig_startup (rwa_desig.c) makes a call to function rcvnet_register_desig_process_packet which registers the designation PDU processing routine with libRcvNet, thus allowing handling of (extension) Designation PDUs.

The RWA software, in conjunction with the test scenarios, can be inspected to comply with the above listed requirements.

VERIFIED: _____

TITLE: _____

CONCURRENCE: _____

AIRNET INSPECTION/ANALYSIS REPORT 5

Req. No.:	ATAC II 3.2.4	Spec. Para.:	3.2
	ATAC II 3.2.5		3.2
	ATAC II 3.2.6		3.2
	ATAC II 3.2.7		3.2
	ATAC II 3.2.13		3.2
	ATAC II 3.2.14		3.2

Requirement Descriptions:

Req. No.: ATAC II 3.2.4 ATAS Symbology

The RWA software shall use the existing ATAS lock-on algorithms for determining which types of entities it can lock on to.

Req. No.: ATAC II 3.2.5 ATAS Symbology

The RWA software shall use the existing ATAS intervisibility algorithms.

Req. No.: ATAC II 3.2.6 ATAS Symbology

The RWA software shall use the existing ATAS maximum lock-on range of 7.0 km.

Req. No.: ATAC II 3.2.7 ATAS Symbology

The RWA software OTW maximum visual range of 3.5 km. shall remain as it is in the current software.

Req. No.: ATAC II 3.2.13 ATAS Symbology

The ATAS reticles shall be displayed for all missiles of type "target_guided" as defined in the RWA data file.

Req. No.: ATAC II 3.2.14 ATAS Symbology

The ATAC reticles shall be displayed for any configuration of the RWA which has selected a "target_guided" missile type.

Inspection Method: During vehicle start up, (sim state IDLE) function weapons_startup is called. This function creates a list of candidate vehicles for Stinger lock on. This vehicle list includes all entities in the exercise whose domain is vehicle and environment is air (as defined by the Activate and Appearance PDUs). The original source and the ATAC II source use the same identical function. Software package rwa_weapons.c can be inspected for verification of compliance with requirement 3.2.4.

Software library libnear contains software packages which house the functions dealing with ATAS intervisibility. These functions identify the nearest visible target and provide this information to missile flight functions. Difference listings of the original source against the ATAC II source reveal changes only to the software package header. This library can be inspected for verification of compliance with requirement 3.2.5.

Software package rwa_weapons.c defines a constant MAX_STINGER_LOCKON_RANGE to have a value of 7000 meters (7.0 km.). Both the original source and ATAC II source contain this declaration. Package rwa_weapons.c can be inspected for verification of compliance with requirement 3.2.6.

The maximum visual range for both the original version of the RWA and the ATAC II version of the RWA is defined in data file rwvconfg.d. This file contains entries of viewing_range 3500 (meters, 3.5 km.). This data file can be inspected for compliance with requirement 3.2.7.

The RWA data file, reconfig.rwa, identifies for each vehicle, its vehicle characteristics, including its weapons configuration. This configuration may include a weapon of type "target_guided". During sim state SIMINIT, a call is made to function firectl_init (rwa_firectl.c). This function in turn makes a call to firectl_was_init (rwa_firectl.c) which initializes the weapon system assignments. For munition types of "target_guided" (as specified in reconfig.rwa) it initializes the state to STINGER. When the "target_guided" weapon type is selected via the WAS, a call is made to function weapons_select_stinger (rwa_weapons.c) which sets the reticle type to that associated with the stinger. Software packages rwa_firectl.c and rwa_weapons.c can be inspected for compliance with requirements 3.2.13 and 3.2.14.

VERIFIED: _____

TITLE: _____

CONCURRENCE: _____

AIRNET INSPECTION/ANALYSIS REPORT 6

Req. No.: ATAC II 3.3.1.12

Spec. Para.: 3.3.1

Requirement Descriptions:

Req. No.: ATAC II 3.3.1.12 Manned Rotary Wing Aircraft

The Hellfire range (calculated from the target UTM grid coordinate or from the laser autorange finder) shall determine the initial value for the Time of Flight (TOF) overlay on the sensor display.

Inspection Method: Function `veh_spec_simulate` is executed when the sim state is `SIM_SIMULATE_STATE`. One of the functions called by `veh_spec_simulate` is `weapons_simul` which in turn calls `missile_simul`. `Missile_simul` provides the simulation model of the missiles (hellfire and stinger). As a part of its functionality, `missile_simul` calls `hellfire_separation` which calls a function called `send_tof_message`. `Send_tof_message` causes the sensor display to be updated to include the time of flight for the hellfire missile. The argument passed to `send_tof_message` is the returned value from a call to `missile_hellfire_calc_tof`. This function calculates the missile's time of flight based upon the range to the target. `Missile_hellfire_calc_tof` uses function `laser_range` to determine the range to the target. `Laser_range` sets the range to the target based upon either the target UTM grid coordinate or the laser autorange finder value. These functions can be inspected to comply with requirement 3.3.1.12.

VERIFIED: _____

TITLE: _____

CONCURRENCE: _____



3200 Zanker Rd.
P.O. Box 49041
San Jose, CA 95161-9041

DOC CODE ADST/WDL/TR-92-003029

Procedure No. **EXERCISE "B"**
TEST CASES 3 & 5

Page 1 of 81

CDRL NO. A009

TABLE OF CONTENTS PAGE NO.

	REVISION HISTORY	2
1.0	SCOPE	3
2.0	APPLICABLE DOCUMENTS	3
3.0	TEST ENVIRONMENT REQUIREMENTS	3
4.0	TEST PREPARATION	4
5.0	TEST PROCEDURE	7
6.0	NOTES	34
7.0	TEST FAILURES/INTERRUPTIONS	35
8.0	GLOSSARY	36
	APPENDIX A	38
	APPENDIX B	41
	APPENDIX C	43

Test Start Time/Date		Test Complete Time/Date	
Prepared Under		Program	ADST/AIRNET RWA
Contract Number	N61339-91-D0001	Equipment Serial Number	N/A
Test Engineer	Date	Test Performed By	Date
Program Engineer	Date	Test Witnessed By	Date
Quality Assurance	Date	Customer Rep	Date
Program Office	Date	Data Reviewed By	Date
		Customer Rep	
Release Date			

WDL 2829A
11-92

92321m.3

[CB-1]



3200 Zanker Rd.
P.O. Box 49041
San Jose, CA 95161-9041

Procedure No. EXERCISE "B"
TEST CASES 3 & 5

Page 2 of 81

CDRL NO. A009

REVISION HISTORY

All revised or amended pages are listed below. Upon receipt, substitute pages of an amendment shall be inserted in the basic document after removal of the superseded pages. Revisions of test procedures shall be used as released.

REVISION	DATE	CHANGED BY	TYPE OF CHANGE OR REASON	PAGES AFFECTED

WDL 2878C
11-92

92321m.3a

LORAL

3200 Zanker Rd.
P.O. Box 49041
San Jose, CA 95161-9041

Procedure No. **EXERCISE "B"**
TEST CASES 3 & 5

CDRL NO. A009

1.0 SCOPE

This document establishes the test procedure for demonstrating the capabilities as described by the requirements listed in Section 5.0 of this document. This test procedure provides for demonstrating Test Cases No. 3 & 5 as described in the AIRNET RWA Acceptance Test Plan. The two test cases were combined to be efficiently demonstrated in one exercise, Exercise "B", as performed during this test.

2.0 APPLICABLE DOCUMENTS

The following documents of the issue shown form a part of the test procedure to the extent specified herein.

- a. Recommended Spares and Support Equipment, DI-V-30801
- b. MCC Operator's Manual, DI-MISC-80711
- c. AIRNET Data Handbook, March 14, 1986.
- d. System Specification for the Rotary Wing Aircraft AIRNET Aeromodel and Weapons Model Conversion, dated 6 June 1992.
- e. Statement of Work for the Acquisition of Rotary Wing Aircraft AIRNET Upgrades, dated 30 March 1992.
- f. AIRNET RWA Acceptance Test Plan, dated 1 Nov. 1992.
- g. DI-DRPR-81002, Developmental Design Drawings and Associated Lists.
- h. RWA System Integration Plan, August 5, 1992.
- i. Software Requirements Specification for Air to Air Combat (ATAC) II AIRNET Experiment, Revision 2.0, 04/10/92.

3.0 TEST ENVIRONMENT REQUIREMENTS

3.1 Test Conditions - Unless otherwise directed, tests shall be performed under ambient laboratory conditions of pressure, temperature, and humidity provided that the temperature is within the range of plus 10 to 40 degrees Celsius.

3.2 Test Witnessing - Test witnessing shall be provided by a representative of the LORAL WDL Quality Assurance and a designated representative of the receiving organization.

3.3 Measurements - Performance measurements are not applicable to this system level test but observations for validation of expected results will be recorded as specified in the test procedure.

3.4 Tolerance - Tolerance measurements are not applicable to this system level test. The tolerances used in the procedures are guidelines and not related to satisfying specific tolerance requirements.

4.0 TEST PREPARATION

4.1 Test Configuration - The following diagram reflects the hardware configuration required for this test. This test configuration is based on the San Jose System Development Facility (SDF) and may require modification when the test is executed at the Ft. Rucker facility. The basic components reflected in this block diagram are required at either facility in support of the execution of this test.

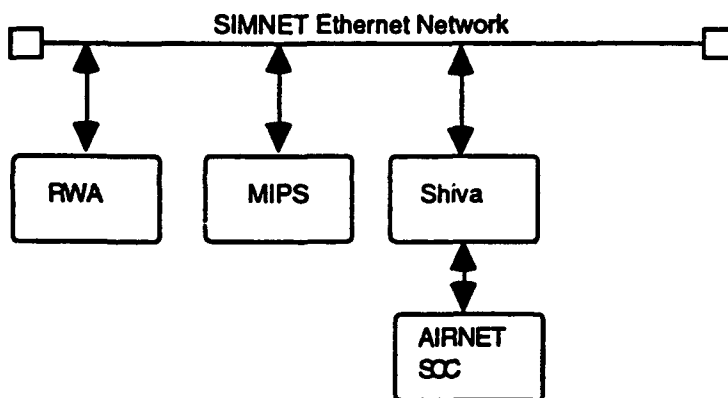

Figure 4.0 - 1 Required System Components

The software configuration required for this test is as follows:

Software	Version
• AIRNET MIPS MCC Phantom	2.0.0
• AIRNET Mac SCC	1.0.0
• GT Operating System	GT 4.7 Apr. 9 13:35:35 PDT 1991
• GT Real Time Software	rttgr5.7
• Rotary Wing Aircraft (RWA)	1.1.0

4.2 System Setup

The system set up procedures for this test are shown in Tables 4.2 - 1 through 2.

Table 4.2 - 1 Rotary Wing Aircraft Simulator Set Up

Action	(√)
Boot the RWA GT-111 Simulator	()
Verify the GT Operating System as GT 4.7	()
Download the RWA executable and data files	()
Calibrate the RWA simulator	()
Verify that the collective mount is in its most downward position	()
Verify that the weapons arming switches are in the armed position	()

Table 4.2 - 2 AIRNET Management, Command and Control Console Set Up

Action	(√)
Load the Mac System Control Console software	()
Load the Mac Admin./Log Console software	()
Download the Masscomp Management, Command and Control software	()
Initiate the MIPS Phantom process using the Fort Knox Data Base	()

4.3 Test Requirements

The technical capabilities and skills required for this test are as follows:

- The optimum number of personnel for the conduct of this test is three (3); however it is possible to conduct this test with a single individual.
- The tester(s) are familiar with the operation of the RWA, including its Pilot and Co-Pilot/Gunner positions.
- The tester(s) are familiar with the operation of the AIRNET (MIPS-based) MCC.

5.0 TEST PROCEDURE

Appendix A of this document, Exercise "B" Requirements Matrix, identifies the requirements to be validated during the execution of the test procedure as provided in this section. This step-by-step procedure provides for an indication on the success or failure of each step as it is executed.

5.1 Test Description - The basis for this test procedure is a simple exercise scenario and its set up. This scenario incorporates data driven flight and weapons models into the existing AIRNET capabilities. A top level description of the test procedure follows.

A rotary wing aircraft is allocated and initialized for the exercise; the baseline data files for the flight and weapons model are used. The aircraft is then taken through several stages of flight and weapons are fired. The exercise is ended and the flight and weapons model data files are modified. The exercise is then repeated.

5.2 Test Procedures - The test procedures which follow demonstrate requirement satisfaction while verifying the use of data driven flight and weapons models within the existing AIRNET system.

After each step is performed, mark the status of the action as:

- S - Satisfactory with no anomaly.
- SA - Satisfactory with an anomaly indicated and documented.
- U - Unsatisfactory with an anomaly indicated and documented.

Note:

- (1) Requirements shown in standard face type are partially satisfied at the point within the test that they are referenced.
- (2) Requirements shown in bold face type are wholly satisfied at the point within the test that they are referenced.
- (3) References to 8B FRED are to a specific simulator located at the Loral WDL SDF. Should this test be run elsewhere, 8B FRED references should be replaced with any like device available at that facility.
- (4) References to a Battlemaster password of "foozball" are specific to the Loral WDL SDF. Should this test be run elsewhere, the correct Battlemaster password must be used.
- (5) This procedure does not attempt to follow standard Army operating procedures.
- (6) This exercise is assumed to be exercise 1.
- (7) This procedure is comprised of two passes through the same flight scenario with comparisons made between the two. Results may vary slightly from the expected results due to the inability to accurately and precisely re-fly the scenario.

5.2.1 Remove Data File from Directory - The steps in this subparagraph consist of instructions for removing a weapons model data file from its home directory.

Step	Operator/System Action	Expected Result	Status (Check One)
10	At the GT-111 system console, use the switch session button to toggle to GT-0 if the display is not already there. Set the default directory to /SIMNET/DATA by entering: cd /SIMNET/DATA <cr> Get a directory listing by entering the command: ls <cr>	The SIMNET/DATA directory contents is displayed. It includes files: MS_TW_BT.D (The Burn Turn Coefficients file for the TOW Missile, a Guided Missile.), MS_ST_CH.D (Characteristics file for the Stinger Missile, a Ballistics Missile), and M789.D (Trajectory file for Ballistic Rounds).	<input checked="" type="checkbox"/> S <input type="checkbox"/> SA <input type="checkbox"/> U
20	Rename the file by entering: mv ms_tw_bt.d tow_bt.d <cr> and wait 10 seconds. Get a directory listing (ls).	The file is renamed tow_bt.d. The directory listing shows no entry for ms_tw_bt.d but includes an entry for tow_bt.d.	<i>previously added</i> <input checked="" type="checkbox"/> S <input type="checkbox"/> SA <input type="checkbox"/> U

5.2.2 Initiate the Real-Time and RWA Simulation Software - The steps in this subparagraph consist of instructions for initiating the real-time and RWA simulation software.

Step	Operator/System Action	Expected Result	Status (Check One)
30	Set the default directory to A:/CIG/CONFIG by entering: cd <cr> Get a directory listing (ls).	The A:/CIG/CONFIG directory contents is displayed. It includes file: runcig	<input checked="" type="checkbox"/> S <input type="checkbox"/> SA <input type="checkbox"/> U
40	Initiate the real time simulation software by entering: source runcig <cr> at the gt-0 > prompt.	The system responds with the following: Verbose mode is OFF === Using mpv interface ===	<input checked="" type="checkbox"/> S <input type="checkbox"/> SA <input type="checkbox"/> U

- 50 Toggle the display to GT-1 by hitting the Switch Session key until GT-1 is reached. Set the default directory to A:/SIMNET/BIN by entering:

```
cd /simnet/bin <cr>
```

Initiate the RWA software by entering:

```
rwa knox.par -k -1 3 -c <cr>
```

The initial display shows a line drawing of a helicopter and identifies the software revision number. This is followed by CIG initialization messages and finally STARTUP INITIALIZATION COMPLETE.

<input checked="" type="checkbox"/>	<input type="checkbox"/>	<input type="checkbox"/>
S	SA	U

5.2.3 Set Up the Exercise at the AIRNET System Control Console - The steps in this subparagraph consist of instructions for initializing the exercise number, the role of the Management, Command and Control Console, and the exercise's geographic area.

<u>Step</u>	<u>Operator/System Action</u>	<u>Expected Result</u>	<u>Status</u> (Check One)						
60	At the Ainet SCC, initiate the SCC process by double clicking on the SCC 1.0.0 AT entry.	A display appears permitting the connection to the network.	<table border="0"> <tr> <td><input checked="" type="checkbox"/></td> <td><input type="checkbox"/></td> <td><input type="checkbox"/></td> </tr> <tr> <td>S</td> <td>SA</td> <td>U</td> </tr> </table>	<input checked="" type="checkbox"/>	<input type="checkbox"/>	<input type="checkbox"/>	S	SA	U
<input checked="" type="checkbox"/>	<input type="checkbox"/>	<input type="checkbox"/>							
S	SA	U							
70	Select the zone (SDF - Loral) by double clicking on the zone entry.	A list of possible hosts appears in the hosts window.	<table border="0"> <tr> <td><input checked="" type="checkbox"/></td> <td><input type="checkbox"/></td> <td><input type="checkbox"/></td> </tr> <tr> <td>S</td> <td>SA</td> <td>U</td> </tr> </table>	<input checked="" type="checkbox"/>	<input type="checkbox"/>	<input type="checkbox"/>	S	SA	U
<input checked="" type="checkbox"/>	<input type="checkbox"/>	<input type="checkbox"/>							
S	SA	U							
80	Select the host (SDF - MIPs 1) by single clicking on the host entry and then clicking on the connect button.	The system responds with a series of windows indicating that initialization is taking place. When initialization is complete the Start Window is displayed.	<table border="0"> <tr> <td><input checked="" type="checkbox"/></td> <td><input type="checkbox"/></td> <td><input type="checkbox"/></td> </tr> <tr> <td>S</td> <td>SA</td> <td>U</td> </tr> </table>	<input checked="" type="checkbox"/>	<input type="checkbox"/>	<input type="checkbox"/>	S	SA	U
<input checked="" type="checkbox"/>	<input type="checkbox"/>	<input type="checkbox"/>							
S	SA	U							
90	At the Ainet SCC, start the exercise initialization process by clicking on the START button.	A display appears showing the exercise number, the MCC role, and the terrain to be used in the exercise.	<table border="0"> <tr> <td><input checked="" type="checkbox"/></td> <td><input type="checkbox"/></td> <td><input type="checkbox"/></td> </tr> <tr> <td>S</td> <td>SA</td> <td>U</td> </tr> </table>	<input checked="" type="checkbox"/>	<input type="checkbox"/>	<input type="checkbox"/>	S	SA	U
<input checked="" type="checkbox"/>	<input type="checkbox"/>	<input type="checkbox"/>							
S	SA	U							
100	Verify that the MCC is participating in Exercise 1.	The MCC is participating in Exercise 1.	<table border="0"> <tr> <td><input checked="" type="checkbox"/></td> <td><input type="checkbox"/></td> <td><input type="checkbox"/></td> </tr> <tr> <td>S</td> <td>SA</td> <td>U</td> </tr> </table>	<input checked="" type="checkbox"/>	<input type="checkbox"/>	<input type="checkbox"/>	S	SA	U
<input checked="" type="checkbox"/>	<input type="checkbox"/>	<input type="checkbox"/>							
S	SA	U							
110	Select the default role of the MCC to be US.	The display shows the default MCC role to be US.	<table border="0"> <tr> <td><input checked="" type="checkbox"/></td> <td><input type="checkbox"/></td> <td><input type="checkbox"/></td> </tr> <tr> <td>S</td> <td>SA</td> <td>U</td> </tr> </table>	<input checked="" type="checkbox"/>	<input type="checkbox"/>	<input type="checkbox"/>	S	SA	U
<input checked="" type="checkbox"/>	<input type="checkbox"/>	<input type="checkbox"/>							
S	SA	U							

120 Verify that the terrain to be used for the exercise is Fort Knox 8/14/90, SW corner: ES450550, NE corner: FT200050
Go to the NEXT menu.

An Overview menu is displayed showing the following selectable options:
Simulator Allocation
Simulator Activation
Command Post Initialization
Service Element Initialization
Battlemaster

S SA U

5.2.4 Set Up the FWA Simulator as a AH-1 - The steps in this subparagraph consist of instructions for initializing a Fully Reconfigurable Device (FRED) as an AH-1.

<u>Step</u>	<u>Operator/System Action</u>	<u>Expected Result</u>	<u>Status</u> (Check One)
130	Select the Simulator Allocation Option and GO to the next menu.	A display appears showing the simulators available for allocation, including one or more FRED simulators.	<input checked="" type="checkbox"/> S <input type="checkbox"/> SA <input type="checkbox"/> U
140	Highlight the 8B FRED entry and click on the ALLOCATE button.	A display appears allowing element assignment.	<input checked="" type="checkbox"/> S <input type="checkbox"/> SA <input type="checkbox"/> U
150	Assign the entity to A Company by double clicking on US Army, then 223rd Attack Helo Battalion, then A Company.	The display shows the entity to be assigned to A Company.	<input checked="" type="checkbox"/> S <input type="checkbox"/> SA <input type="checkbox"/> U
160	Click on the ASSIGN button.	A display appears showing the simulators available for activation, including 8B FRED which is now shown as assigned to A Company, but not yet placed.	<input checked="" type="checkbox"/> S <input type="checkbox"/> SA <input type="checkbox"/> U
170	Click on the Overview button.	The Overview menu is displayed.	<input checked="" type="checkbox"/> S <input type="checkbox"/> SA <input type="checkbox"/> U
180	Select the Simulator Activation Option and GO to the next menu.	A display appears allowing simulator activation.	<input checked="" type="checkbox"/> S <input type="checkbox"/> SA <input type="checkbox"/> U
190	Activate the simulator in A Company by double clicking on US Army, then 223rd Attack Helo Battalion, then A Company.	The display shows the simulator to be activated in A Company.	<input checked="" type="checkbox"/> S <input type="checkbox"/> SA <input type="checkbox"/> U
200	Set a default location of FS085902 and verify that the default force is US. Go to the NEXT menu.	A display appears showing the activated simulators, 8B FRED is assigned to A Company, but not yet placed.	<input checked="" type="checkbox"/> S <input type="checkbox"/> SA <input type="checkbox"/> U

210 Highlight the 8B FRED entry by clicking on the entry and go to the NEXT menu.

A display appears allowing simulator customization.

S SA U

220 Customize the 8B FRED with a tail number of 2, a location of FS085902, a heading of 0 degrees, an alignment of US, a maintenance status of New, and a vehicle type of AH-1.

The display reflects the custom selections.

S SA U

230 Verify that the default weapons load is:

20 mm Gatting: 750 Rounds
 Stinger: 4
 TOW: 8
 Hydra 70 10 lb: 0
 Hydra 70 MPSM: 38
 Hydra 70 Flechette: 0

The display reflects the custom selections and a default weapons load.

S SA U

240 Verify that the default fuel load is: 1703 lbs.

The display reflects the custom selections and a default fuel load.

S SA U

250 Select the ACTIVATE button.

A display appears showing the activated simulators, 8B FRED is assigned to A Company, placed. The activate PDU is sent across the network initiating the initialization of the system, including the weapons segment.

- 3.2.1.5.1
- 3.2.1.5.1.1.1
- 3.2.1.5.1.1.3
- 3.2.1.5.1.1.5
- 3.2.1.5.1.2.1
- 3.2.1.5.1.2.2
- 3.2.1.5.1.2.3

S SA U

260 Click on the Overview button.

The Overview menu is displayed.

S SA U

If this the second pass through these steps go to Step 400.

5.2.5 Verify that the Weapons Data File is not Found - The steps in this subparagraph consist of instructions for verifying that the renamed weapons data file was not found.

Step	Operator/System Action	Expected Result	Status (Check One)
270	At the GT-111 system console (gt-1) verify the display of the following message: Cannot open /sinnet/data/ms_tw_ch.d	The specified message is displayed. (The RWA software attempted to open the file, but because it was renamed, it was not found.) *3.2.1.3.2.2.3	<input checked="" type="checkbox"/> S <input type="checkbox"/> SA <input type="checkbox"/> U <i>Previously done</i>
280	Using the switch session button, toggle to GT-0. Hit the return key.	The system responds with the GOSSIP> prompt.	<input checked="" type="checkbox"/> S <input type="checkbox"/> SA <input type="checkbox"/> U
290	Enter "Q" to quit the real time simulation software.	A query is displayed asking if you are sure you want to quit.	<input checked="" type="checkbox"/> S <input type="checkbox"/> SA <input type="checkbox"/> U
300	Enter y (YES) <cr> in response to the query.	The system displays shutdown messages and returns to the gt-0 > prompt.	<input checked="" type="checkbox"/> S <input type="checkbox"/> SA <input type="checkbox"/> U
310	If the execution did not terminate properly (i.e. error messages are displayed), reboot the GT-111 by hitting the reset button on the GT-111 or by entering "reboot" at the GT-0 prompt.	The GT-111 system is rebooted. The gt-0 display shows: Starting mpv component Configured as GT111 The gt-1 display shows: Configured as GT111 The situational and instructional displays are presented with default values.	<input checked="" type="checkbox"/> S <input type="checkbox"/> SA <input type="checkbox"/> U
320	At the AIRNET SCC, select the Battlemaster Functions Option and GO to the next menu.	A display appears requesting the Battlemaster password.	<input checked="" type="checkbox"/> S <input type="checkbox"/> SA <input type="checkbox"/> U
330	Enter the Battlemaster password (foozball) and click on the OK button.	The Battlemaster Overview menu is displayed showing the following selectable options: Displacement Reconstitute Gunnery Targets Resume Initialization End Exercise	<input checked="" type="checkbox"/> S <input type="checkbox"/> SA <input type="checkbox"/> U
340	Select the End Exercise option and GO to the next menu.	An End Exercise Confirmation Menu is displayed.	<input checked="" type="checkbox"/> S <input type="checkbox"/> SA <input type="checkbox"/> U

350 Respond to the Confirmation Question by clicking on YES.

The Confirmation Display disappears and the display returns to the Macintosh windows screen.

S SA U

5.2.6 Replace Data File in Directory and Set Up System - The steps in this subparagraph consist of instructions for replacing the weapons model data file in its home directory and resetting the system.

<u>Step</u>	<u>Operator/System Action</u>	<u>Expected Result</u>	<u>Status</u> (Check One)
360	At the GT-111 system console, use the switch session button to toggle to GT-0 if the display is not already there. Set the default directory to /SIMNET/DATA by entering: cd /SIMNET/DATA <cr> Get a directory listing by entering the command: ls <cr>	The SIMNET/DATA directory contents is displayed. It includes file: TOW_BT.D (The Burn Turn coefficients file for the TOW Missile, a Guided Missile.)	<input type="checkbox"/> S <input type="checkbox"/> SA <input type="checkbox"/> U
			<i>steps 360-390 previously completed.</i>
370	Rename the file by entering: mv tow_bt.d ms_tw_bt.d <cr> and wait 10 seconds. Get a directory listing (ls).	The file is renamed to ms_tw_bt.d. The directory listing shows no entry for tow_bt.d but includes an entry for ms_tw_bt.d.	<input type="checkbox"/> S <input type="checkbox"/> SA <input type="checkbox"/> U
380	Repeat steps 360 to reset the system.	The aircraft is initialized, the visuals and sound are active.	<input type="checkbox"/> S <input type="checkbox"/> SA <input type="checkbox"/> U
390	Verify that no message indicating that the file could not be found is output to the GT-111 system console.	No message indicating that the file could not be opened is output to the GT-111 system console. •3.2.1.3.2.2.3 •3.2.1.5	<input checked="" type="checkbox"/> S <input type="checkbox"/> SA <input type="checkbox"/> U

5.2.7 Set Up Targets - The steps in this subparagraph consist of instructions for initializing Gunnery Targets.

<u>Step</u>	<u>Operator/System Action</u>	<u>Expected Result</u>	<u>Status</u> (Check One)
400	Select the Battlemaster Functions Option and GO to the next menu.	A display appears requesting the Battlemaster password.	<input checked="" type="checkbox"/> S <input type="checkbox"/> SA <input type="checkbox"/> U

- | | | |
|-------------------------------------------------------------------------------------------------------------------------------------------------------------------------------------------------------------------------------------------------------------------------------------------------------------------------------------------------------------------------------------------------------------------------|------------------------------------------------------------------------------------------------------------------------------------------------------------------------------------------------------------------------------------------------------------------------------------|-----------------------------------------------------------------------------------------------------------|
| <p>410 Enter the Battlemaster password (foozball) and click on the OK button.</p> | <p>The Battlemaster Overview menu is displayed showing the following selectable options:
 Displacement
 Reconstitute
 Gunnery Targets
 Resume Initialization
 End Exercise</p> | <p><input checked="" type="checkbox"/> S <input type="checkbox"/> SA <input type="checkbox"/> U</p> |
| <p>420 Select the Gunnery Targets Option and GO to the next menu.</p> | <p>A display allowing Gunnery Target Specification appears.</p> | <p><input checked="" type="checkbox"/> S <input type="checkbox"/> SA <input type="checkbox"/> U</p> |
| <p>430 Enter the gunnery targets as:
 Target 1, US, FWA,
 ES94808550, 2435
 Target 2, US, FWA,
 ES94938510, 2435
 Target 3, US, FWA,
 ES95108460, 2435
 Target 4, US, FWA,
 ES95238420, 2435
 and click on the Overview button.</p> | <p>The Battlemaster Overview menu is displayed.</p> | <p><input checked="" type="checkbox"/> S <input type="checkbox"/> SA <input type="checkbox"/> U</p> |

5.2.8 Fly Aircraft Through Flight Envelope Phases - The steps in this subparagraph consist of instructions for flying the aircraft through the following flight envelope phases: Ascent, Hover, Cruise, Descent and Low Level Flight.

<u>Step</u>	<u>Operator/System Action</u>	<u>Expected Result</u>	<u>Status</u> (Check One)
<p>440 At the AH-1 softpanel, enter a waypoint at ES979898, and select it for navigation.</p>		<p>The Situational Display shows a 1 indicating the waypoint position relative to the aircraft's current location and heading (represented by the center crosshairs). It also identifies the aircraft's current position (grid coordinates FS085902), the bearing to the waypoint (approx. 267 deg.) and the range to the waypoint (approx. 10608 m.).</p>	<p><input checked="" type="checkbox"/> S <input type="checkbox"/> SA <input type="checkbox"/> U</p>
<p>450 Record the amount of fuel and the current time:</p> <p>Fuel: <u>1700</u> lbs.</p> <p>Time: <u>2:28</u></p>		<p>The fuel level is displayed on the Instructional Display.</p>	<p><input checked="" type="checkbox"/> S <input type="checkbox"/> SA <input type="checkbox"/> U</p>

- 460 Take off noting the torque at the point of liftoff. Ascend to an altitude of 1000 ft. above sea level and hover.

Torque: 68 lbs.

Enter this value as Torque 1 in Step 1990:
1410

The flight model mode transitions from Idle to Execute and flight modeling begins. The flight controls and dynamics characteristics of the aircraft are simulated. The aircraft ascent is representative of the data in the flight model data files and the system responds in real-time to the pilot's input.

- 3.2.1.3.2.1.2
- 3.2.1.3.2.2.5
- 3.2.1.3.2.2.6
- 3.2.1.3.2.2.6.b (ascent)

S SA U

- 470 Hover at 1000 ft. above sea level for one minute.

The aircraft hover is representative of the data in the flight model data files and the system responds in real-time to the pilot's input.

- 3.2.1.3.2.2.6.b (hover)

S SA U

- 480 Fly at a constant cruise speed of approximately 100 knots with a heading of approximately 267 degrees till you reach the waypoint area (3 - 4 minutes).

The aircraft cruise is representative of the data in the flight model data files and the system responds in real-time to the pilot's input.

- 3.2.1.3.2.2.6.b (cruise)

S SA U

- 490 Descend to an altitude of 35 - 45 ft. above ground level and hover.

The aircraft descent is representative of the data in the flight model data files and the system responds in real-time to the pilot's input.

- 3.2.1.3.2.2.6.b (descent)

S SA U

- 500 At the AH-1 softpanel, enter a waypoint at ES948855, and select it for navigation.

The Situational Display shows a 2 indicating the waypoint position relative to the aircraft's current location and heading.

S SA U

- 510 Fly at a speed of 50 knots and at a constant altitude of 35 - 45 ft. above ground level at a heading of approximately 206 degrees until the target area is approximately 1250 ~~4000~~ meters away. Hover at an altitude of approximately 300 ft.

The aircraft's low level flight is representative of the data in the flight model data files and the system responds in real-time to the pilot's input.

- 3.2.1.3.2.2.4
- 3.2.1.3.2.2.6.b (low lvl flt)

S SA U

5.2.9 Fire on the Targets and Land - The steps in this subparagraph consist of instructions for firing on the targets and landing the aircraft.

Step	Operator/System Action	Expected Result	Status (Check One)
520	At the AH-1 Pilot Station, keeping the nose of the aircraft level with the horizon, select the 20 mm Gatling Gun (ballistics rounds) for firing by pushing up on the weapons action switch.	The Pilot's 20 mm gun selection light transitions from unlit to lit.	<input checked="" type="checkbox"/> S <input type="checkbox"/> SA <input type="checkbox"/> U
530	Fire the gun expending approximately 20 - 30 rounds. Note the trajectory of flight for the fired rounds.	The rounds fly out in a gentle arc, representative of the data in the weapons model files.	<input checked="" type="checkbox"/> S <input type="checkbox"/> SA <input type="checkbox"/> U
540	Deselect the Gatling Gun by pushing up on the weapons action switch.	The Pilot's 20 mm gun selection light transitions from lit to unlit.	<input checked="" type="checkbox"/> S <input type="checkbox"/> SA <input type="checkbox"/> U
550	At the AH-1 Co-Pilot/Gunner Station, select the Stinger Missile (ballistic missile) for firing by pushing down on the weapons action switch.	The Co-Pilots Stinger selection light transitions from unlit to lit.	<input checked="" type="checkbox"/> S <input type="checkbox"/> SA <input type="checkbox"/> U
560	Use the Manual Tracker to track one of the targets until the target is within the bounds of the dashed box of the line of sight reticle.	The target is within the bounds of the line of sight reticle.	<input checked="" type="checkbox"/> S <input type="checkbox"/> SA <input type="checkbox"/> U
570	Pull the trigger to the first detent. <i>st</i>	An aural seek tone is heard. <i>Tone on second try</i>	<input checked="" type="checkbox"/> S <input type="checkbox"/> SA <input type="checkbox"/> U
580	At the AH-1 Pilot Position, maneuver the aircraft into Stinger prelaunch constraints (+/- 10 degrees).	When the aircraft is positioned within the +/- 10 degree constraints missile lock-on is achieved.	<input type="checkbox"/> S <input type="checkbox"/> SA <input type="checkbox"/> U
590	At the AH-1 Co-Pilot/Gunner Position, fire on the target by pulling the weapons trigger switch to the second detent.	The missile is launched, flies towards the target and impacts.	<input checked="" type="checkbox"/> S <input type="checkbox"/> SA <input type="checkbox"/> U
600	Deselect the Stinger by pushing up on the weapons action switch.	The Co-Pilot's Stinger selection light transitions from lit to unlit.	<input checked="" type="checkbox"/> S <input type="checkbox"/> SA <input type="checkbox"/> U

- | | | | |
|-----|----------------------------------------------------------------------------------------------------------------------------------------------------|-------------------------------------------------------------------------------------|----------------------------------------------------------------------------------------------|
| 610 | At the AH-1 Co-Pilot/Gunner Station, select the TOW Missile (guided missile) for firing by pushing towards the right on the weapons action switch. | The Co-Pilots TOW selection light transitions from unlit to lit. | <input checked="" type="checkbox"/> S <input type="checkbox"/> SA <input type="checkbox"/> U |
| 620 | Use the Manual Tracker to track one of the targets until the target is within the bounds of the dashed box of the line of sight reticle. | The target is within the bounds of the line of sight reticle. | <input checked="" type="checkbox"/> S <input type="checkbox"/> SA <input type="checkbox"/> U |
| 630 | At the AH-1 Pilot Position, maneuver the aircraft into TOW prelaunch constraints. | When the aircraft is positioned within the constraints missile lock-on is achieved. | <input checked="" type="checkbox"/> S <input type="checkbox"/> SA <input type="checkbox"/> U |
| 640 | At the AH-1 Co-Pilot/Gunner Position, fire on the target by pulling in the weapons trigger switch. | The missile is launched, flies towards the target and impacts. | <input checked="" type="checkbox"/> S <input type="checkbox"/> SA <input type="checkbox"/> U |
| 650 | Deselect the TOW by pushing towards the right on the weapons action switch. | The Co-Pilot's TOW selection light transitions from lit to unlit. | <input checked="" type="checkbox"/> S <input type="checkbox"/> SA <input type="checkbox"/> U |
| 660 | At the AH-1 Pilot Station, land the aircraft. | The aircraft lands and flight modeling is stopped. | <input checked="" type="checkbox"/> S <input type="checkbox"/> SA <input type="checkbox"/> U |
| 670 | Record the current fuel level and the current time: | The fuel level is available from the Instructional Display. | <input checked="" type="checkbox"/> S <input type="checkbox"/> SA <input type="checkbox"/> U |

Fuel Level: 1520 lbs.
 Time: 2:46

Compute the fuel rate over time:

Fuel Consumption Rate: 10 lbs./min.

Record this value at Step 1590 as Pass 1 Fuel Rate.

5.2.10 Terminate the Exercise - The steps in this subparagraph consist of instructions for terminating the exercise.

<u>Step</u>	<u>Operator/System Action</u>	<u>Expected Result</u>	<u>Status</u> (Check One)
680	At the AIRNET SCC, select the End Exercise option and GO to the next menu.	An End Exercise Confirmation Menu is displayed.	<input checked="" type="checkbox"/> S <input type="checkbox"/> SA <input type="checkbox"/> U

- | | | |
|---------------------------------------------------------------------------------------------------------------------------------------------------|----------------------------------------------------------------------------------------------------------------------------------------------------------------------------------------------------------------------------------------------------------------------|----------------------------------------------------------------------------------------------|
| 690 Respond to the Confirmation Question by clicking on YES. | The Confirmation Display disappears and the display returns to the Macintosh windows screen. The CIG visuals and sound are terminated. | <input checked="" type="checkbox"/> S <input type="checkbox"/> SA <input type="checkbox"/> U |
| 700 At the GT-111 system console, verify that the simulation software is terminated. (The system displays the message SIMULATOR STOPPED.) | The simulation is terminated. | <input checked="" type="checkbox"/> S <input type="checkbox"/> SA <input type="checkbox"/> U |
| 710 Enter q to quit the GT-1 simulation software. | CIG stop messages and PDU statistics are displayed followed by the gt-1 > prompt. | <input checked="" type="checkbox"/> S <input type="checkbox"/> SA <input type="checkbox"/> U |
| 720 Using the Switch Session key, toggle the GT-111 system console display to GT-0 and hit return. | The GOSSIP > prompt is displayed. | <input checked="" type="checkbox"/> S <input type="checkbox"/> SA <input type="checkbox"/> U |
| 730 Enter Q to quit the GT-0 simulation software. | A query is displayed asking if you are sure you want to quit. | <input checked="" type="checkbox"/> S <input type="checkbox"/> SA <input type="checkbox"/> U |
| 740 Enter y (YES) <cr> in response to the query. | The system displays system shutdown messages and returns to the gt-0 > prompt. | <input checked="" type="checkbox"/> S <input type="checkbox"/> SA <input type="checkbox"/> U |
| 750 If the execution did not terminate properly (i.e. error messages are displayed), reboot the GT-111 by hitting the reset button on the GT-111. | <p>The GT-111 system is rebooted. The gt-0 display shows:</p> <p>Starting mpv component
Configured as GT 111</p> <p>The gt-1 display shows:</p> <p>Configured as GT 111</p> <p>The situational and instructional displays are presented with default values.</p> | <input checked="" type="checkbox"/> S <input type="checkbox"/> SA <input type="checkbox"/> U |

5.2.11 Modify the Weapons Model - The steps in this subparagraph consist of instructions for modifying the weapons model data tables.

<u>Step</u>	<u>Operator/System Action</u>	<u>Expected Result</u>	<p style="text-align: center;">Status (Check One)</p> <p style="text-align: center;"> <input checked="" type="checkbox"/> S <input type="checkbox"/> SA <input type="checkbox"/> U </p>
760	<p>At the GT-111 system console, use the switch session button to toggle to GT-0 if the display is not already there. Set the default directory to /SIMNET/DATA by entering:</p> <p style="padding-left: 20px;">cd A:/SIMNET/DATA <cr></p> <p>Get a directory listing by entering the command:</p> <p style="padding-left: 20px;">ls <cr></p> <p>You will be modifying baseline files. It is suggested that you make a copy of these files so that they may be easily restored at the completion of the exercise. The files to be modified are:</p> <p style="padding-left: 20px;">ms_tw_cs.d ms_st_ch.d m789.d rwa_aero.d rwa_engn.d</p>	<p>The /SIMNET/DATA directory contents is displayed. It includes files:</p> <p>Guided Missile Files: MS_TW_CH.D (Characteristics) MS_TW_BT.D (Trajectory Data) MS_TW_CT.D (Trajectory Data)</p> <p>Ballistic Missile Files: MS_ST_CH.D (Characteristics) MS_ST_BS.D (Burn Speed Data) MS_ST_CS.D (Coast Speed Data)</p> <p>Ballistic Rounds File: M789.D (Trajectory Data)</p>	<p style="text-align: center;"> <input checked="" type="checkbox"/> S <input type="checkbox"/> SA <input type="checkbox"/> U </p>
770	<p>Initiate the text editor by entering:</p> <p style="padding-left: 20px;">vi ms_tw_cs.d <cr></p>	<p>The editor is initiated and the contents of file ms_tw_cs.d is displayed.</p>	<p style="text-align: center;"> <input checked="" type="checkbox"/> S <input type="checkbox"/> SA <input type="checkbox"/> U </p>
780	<p>Hit the j key until the cursor is positioned on the line containing the a-3 coefficient.</p>	<p>The cursor is positioned on the line containing the a₃ coefficient.</p>	<p style="text-align: center;"> <input checked="" type="checkbox"/> S <input type="checkbox"/> SA <input type="checkbox"/> U </p>
790	<p>Hit the l key until the cursor is positioned on the exponent sign ⁽⁺⁾ character of the a₃ entry. marker</p>	<p>The cursor is positioned on the exponent sign of the a₃ coefficient.</p>	<p style="text-align: center;"> <input checked="" type="checkbox"/> S <input type="checkbox"/> SA <input type="checkbox"/> U </p>
800	<p>Hit the R key, then the space bar twice, then the esc key.</p>	<p>The negative sign and seven ^{is} are deleted.</p>	<p style="text-align: center;"> <input checked="" type="checkbox"/> S <input type="checkbox"/> SA <input type="checkbox"/> U </p>
810	<p>Save the modified file contents by entering:</p> <p style="padding-left: 20px;">ZZ</p>	<p>The file is saved and the prompt returns to gt-0 > .</p>	<p style="text-align: center;"> <input checked="" type="checkbox"/> S <input type="checkbox"/> SA <input type="checkbox"/> U </p>
	<p>Wait 10 seconds.</p>		

- | | | |
|-------------------------------------------------------------------------------------------------------------------------------------------------------------------------------|------------------------------------------------------------------------------------------|----------------------------------------------------------------------------------------------|
| <p>820 At the prompt enter:</p> <p><code>more ms_tw_cs.d <cr></code></p> <p>to display the file's contents.
Verify that the file's contents have been modified.</p> | <p>The file's contents have been modified.
•3.2.1.5.1.1.2</p> | <input checked="" type="checkbox"/> S <input type="checkbox"/> SA <input type="checkbox"/> U |
| <p>830 Initiate the text editor by entering:</p> <p><code>vi ms_st_ch.d <cr></code></p> | <p>The editor is initiated and the contents of file ms_st_ch.d is displayed.</p> | <input checked="" type="checkbox"/> S <input type="checkbox"/> SA <input type="checkbox"/> U |
| <p>840 Hit the j key until the cursor is positioned on the line containing the STINGER_LOCK_THRESHOLD value.</p> | <p>The cursor is positioned on the line containing the STINGER_LOCK_THRESHOLD value.</p> | <input checked="" type="checkbox"/> S <input type="checkbox"/> SA <input type="checkbox"/> U |
| <p>850 Hit the l key until the cursor is positioned on the nine (9) of the STINGER_LOCK_THRESHOLD value.</p> | <p>The cursor is positioned on the 9 of the STINGER_LOCK_THRESHOLD value.</p> | <input checked="" type="checkbox"/> S <input type="checkbox"/> SA <input type="checkbox"/> U |
| <p>860 Hit the R key, then enter:</p> <p><code>0.500000000</code></p> <p>then hit the esc key.</p> | <p>The original value is replaced with 0.5.</p> | <input checked="" type="checkbox"/> S <input type="checkbox"/> SA <input type="checkbox"/> U |
| <p>870 Repeat the above steps for the THETA_0 value, entering a new value of .1047.</p> | <p>The THETA_0 value entry reflects the new value.</p> | <input checked="" type="checkbox"/> S <input type="checkbox"/> SA <input type="checkbox"/> U |
| <p>880 Save the modified file contents by entering:</p> <p><code>ZZ</code></p> <p>Wait ten seconds.</p> | <p>The file is saved and the prompt returns to gt-0 > .</p> | <input checked="" type="checkbox"/> S <input type="checkbox"/> SA <input type="checkbox"/> U |
| <p>890 At the prompt enter:</p> <p><code>more ms_st_ch.d <cr></code></p> <p>to display the file's contents.
Verify that the file's contents have been modified.</p> | <p>The file's contents have been modified.
•3.2.1.5.1.1.4</p> | <input checked="" type="checkbox"/> S <input type="checkbox"/> SA <input type="checkbox"/> U |
| <p>900 Initiate the text editor by entering:</p> <p><code>vi m789.d <cr></code></p> | <p>The editor is initiated and the contents of file m789.d is displayed.</p> | <input checked="" type="checkbox"/> S <input type="checkbox"/> SA <input type="checkbox"/> U |

- | | | |
|----------------------------------------------------------------------------------------------------------------------------------------------------|--------------------------------------------------------------------------|----------------------------------------------------------------------------------------------|
| <p>910 Hit the j key until the cursor is positioned on the line containing the second entry (0.033 is the first entry on the line).</p> | <p>The cursor is positioned on the line containing the second entry.</p> | <input checked="" type="checkbox"/> S <input type="checkbox"/> SA <input type="checkbox"/> L |
| <p>920 Hit the l key until the cursor is positioned over the third entry of the second line (0.018694).</p> | <p>The cursor is positioned on the third entry of the second line.</p> | <input checked="" type="checkbox"/> S <input type="checkbox"/> SA <input type="checkbox"/> L |
| <p>930 Hit the R key, then enter:
1.869400
then hit the esc key.</p> | <p>The original value is replaced with 1.8694.</p> | <input checked="" type="checkbox"/> S <input type="checkbox"/> SA <input type="checkbox"/> L |
| <p>940 Save the modified file contents by entering:
ZZ
Wait ten seconds.</p> | <p>The file is saved and the prompt returns to gt-0 > .</p> | <input checked="" type="checkbox"/> S <input type="checkbox"/> SA <input type="checkbox"/> L |
| <p>950 At the prompt enter:
more m789.d <cr>
to display the file's contents. Verify that the file's contents have been modified.</p> | <p>The file's contents have been modified.
*3.2.1.5.1.1.6</p> | <input checked="" type="checkbox"/> S <input type="checkbox"/> SA <input type="checkbox"/> L |

5.2.12 Modify Flight Model - The steps in this subparagraph consist of instructions for modifying flight modal data tables.

<u>Step</u>	<u>Operator/System Action</u>	<u>Expected Result</u>	<u>Status</u> (Check One)
<p>960 Get a directory listing by entering the command: ls <cr></p>	<p>The /SIMNET/DATA directory contents is displayed. It includes files: Flight Control & Dynamics Files: rwa_kine.d rwa_aero.d Engine Files: rwa_engn.d rw_en_in.d</p>	<input checked="" type="checkbox"/> S <input type="checkbox"/> SA <input type="checkbox"/> L	

- | | | |
|------------------------------------------------------------------------------------------------------------------------------------------------------------------------------------------------------------------------------------------------------------------------------------------------------------------------------------------------------------------------------------------------------------------------------------------|---------------------------------------------------------------------------------------------------------------------------------------------------------------------|-----------------------------------------------------------------------------------------------------------|
| <p>970 Verify that file rwa_aero.d contains (in part) the following flight controls and dynamics data by entering:</p> <p style="padding-left: 40px;">more rwa_aero.d <cr></p> <p>and observing entries for:</p> <p style="padding-left: 40px;">AIRFRAME MASS
GRAV_CONSTANT
VIRTUAL_WING_AREA
VSTAB_COP_AC_X
MAIN_ROTOR_COP_AC_X
HOVER_AUG_ROLL_P_GAIN
HOVER_AUG_PITCH_I_GAIN
HOVER_AUG_YAW_I_GAIN</p> | <p>The file contains the identified flight controls and dynamics data.</p> <ul style="list-style-type: none"> •3.2.1.3.1.1.1 •3.2.1.3.1.2.1 | <p><input checked="" type="checkbox"/> S <input type="checkbox"/> SA <input type="checkbox"/> U</p> |
| <p>980 Verify that file rwa_engn.d contains (in part) the following engine data by entering:</p> <p style="padding-left: 40px;">more rwa_engn.d <cr></p> <p>and observing entries for:</p> <p style="padding-left: 40px;">GOVERNOR_ENGINE_SPEED_SETTING
MAX_ENGINE_PERCENT_POWER
MAIN_ROTOR_GEAR_RATIO
POWERTRAIN_INERTIA
MAX_FUELFLOW</p> | <p>The file contains the identified engine data.</p> <ul style="list-style-type: none"> •3.2.1.3.1.3.1 | <p><input checked="" type="checkbox"/> S <input type="checkbox"/> SA <input type="checkbox"/> U</p> |
| <p>990 Initiate the text editor by entering:</p> <p style="padding-left: 40px;">vi rwa_aero.d <cr></p> | <p>The editor is initiated and the contents of file rwa_aero.d is displayed.</p> | <p><input checked="" type="checkbox"/> S <input type="checkbox"/> SA <input type="checkbox"/> U</p> |
| <p>1000 Hit the j key until the cursor is positioned on the line containing the ORDNANCE_MASS.</p> | <p>The cursor is positioned on the line containing the ORDNANCE_MASS.</p> | <p><input checked="" type="checkbox"/> S <input type="checkbox"/> SA <input type="checkbox"/> U</p> |
| <p>1010 Hit the l key until the cursor is positioned on the first character of the ORDNANCE_MASS (1).</p> | <p>The cursor is positioned on the first character of the ORDNANCE_MASS value (1).</p> | <p><input checked="" type="checkbox"/> S <input type="checkbox"/> SA <input type="checkbox"/> U</p> |
| <p>1020 Hit the R key, then enter:</p> <p style="padding-left: 40px;">3591.0</p> <p>then hit the esc key.</p> | <p>The original value is replaced with 3591.0.</p> | <p><input checked="" type="checkbox"/> S <input type="checkbox"/> SA <input type="checkbox"/> U</p> |

- | | | |
|-------------------------------------------------------------------------------------------------------------------------------------------------------------------------------------------|--------------------------------------------------------------------------------------------------------------------------|----------------------------------------------------------------------------------------------|
| <p>1030 Save the modified file contents by entering:</p> <p style="text-align: center;">ZZ</p> <p>Wait ten seconds.</p> | <p>The file is saved and the prompt returns to gt-0 > .</p> | <input checked="" type="checkbox"/> S <input type="checkbox"/> SA <input type="checkbox"/> U |
| <p>1040 At the prompt enter:</p> <p style="padding-left: 40px;">more rwa_aero.d <cr></p> <p>to display the file's contents. Verify that the file's contents have been modified.</p> | <p>The file's contents have been modified.</p> <p>•3.2.1.3.1.1.1.2
•3.2.1.3.1.2.1.2</p> | <input checked="" type="checkbox"/> S <input type="checkbox"/> SA <input type="checkbox"/> U |
| <p>1050 Initiate the text editor by entering:</p> <p style="padding-left: 40px;">vi rwa_engn.d <cr></p> | <p>The editor is initiated and the contents of file rwa_engn.d is displayed.</p> | <input checked="" type="checkbox"/> S <input type="checkbox"/> SA <input type="checkbox"/> U |
| <p>1060 Hit the j key until the cursor is positioned on the last line of the file (MAX_FUELFLOW).</p> | <p>The cursor is positioned on the last line of the file.</p> | <input checked="" type="checkbox"/> S <input type="checkbox"/> SA <input type="checkbox"/> U |
| <p>1070 Hit the l key until the cursor is positioned on the first digit of the MAX_FUELFLOW entry.</p> | <p>The cursor is positioned on the first digit of the MAX_FUELFLOW entry.</p> | <input checked="" type="checkbox"/> S <input type="checkbox"/> SA <input type="checkbox"/> U |
| <p>1080 Hit the R key, then enter</p> <p style="padding-left: 40px;">770.000000</p> <p>then hit the esc key.</p> | <p>The original value is replaced with 770 4540.0 (approximately 10 times the original value).</p> | <input checked="" type="checkbox"/> S <input type="checkbox"/> SA <input type="checkbox"/> U |
| <p>1090 Save the modified file contents by entering:</p> <p style="text-align: center;">ZZ</p> <p>Wait ten seconds.</p> | <p>The file is saved and the prompt returns to gt-0 > .</p> | <input checked="" type="checkbox"/> S <input type="checkbox"/> SA <input type="checkbox"/> U |
| <p>1100 At the prompt enter:</p> <p style="padding-left: 40px;">more rwa_engn.d <cr></p> <p>to display the file's contents. Verify that the file's contents have been modified.</p> | <p>The file's contents have been modified.</p> <p>•3.2.1.3.1.3.1.2</p> | <input checked="" type="checkbox"/> S <input type="checkbox"/> SA <input type="checkbox"/> U |

5.2.13 Initiate the Real-Time and RWA Simulation Software - The steps in this subparagraph consist of instructions for initiating the real-time and RWA simulation software.

<u>Step</u>	<u>Operator/System Action</u>	<u>Expected Result</u>	<u>Status</u> (Check One)
1110	At the GT-111 system console, use the switch session button to toggle to GT-0 if the display is not already there. Set the default directory to A:/CIG/CONFIG by entering: cd <cr> Get a directory listing by entering the command: ls <cr>	The A:/CIG/CONFIG directory contents is displayed. It includes file: runcig	<input checked="" type="checkbox"/> S <input type="checkbox"/> SA <input type="checkbox"/> U
1120	Initiate the real time simulation software by entering: source runcig <cr> at the gt-0 > prompt.	The system responds with the following: Verbose mode is OFF === Using mpv interface ===	<input checked="" type="checkbox"/> S <input type="checkbox"/> SA <input type="checkbox"/> U
1130	Toggle the display to GT-1 by hitting the Switch Session key until GT-1 is reached. Set the default directory to A: by entering: cd <cr> Initiate the RWA software by entering: rwa knox.par -k -1 3 -c <cr> at the gt-1 > prompt.	The initial display shows a line drawing of a helicopter and identifies the software revision number. This is followed by CIG initialization messages and finally STARTUP INITIALIZATION COMPLETE •3.2.1.3.1	<input checked="" type="checkbox"/> S <input type="checkbox"/> SA <input type="checkbox"/> U

5.2.14 Initiate the AIRNET Management Command and Control Console Software - The steps in this subparagraph consist of instructions for initiating the AIRNET MCC software.

<u>Step</u>	<u>Operator/System Action</u>	<u>Expected Result</u>	<u>Status</u> (Check One)
1140	At the Airnet SCC, initiate the SCC process by double clicking on the AIRNET SCC 1.0.0 entry. 2	The Macintosh windows display is replaced by a Connect Window.	<input checked="" type="checkbox"/> S <input type="checkbox"/> SA <input type="checkbox"/> U

1150 Double click on the Loral zone entry, then single click on the MIPS host entry. Click on the CONNECT button.

The system connects to the network and system loading messages are displayed for a couple of minutes. When system loading is complete, the SCC Start Display is presented.

S SA U

5.2.15 Set Up the Exercise at the AIRNET System Control Console - The steps in this subparagraph consist of instructions for initializing the exercise number, the role of the Management Command, and Control Console, and the exercise's geographic area.

<u>Step</u>	<u>Operator/System Action</u>	<u>Expected Result</u>	<u>Status</u> (Check One)
1160	At the Airnet SCC, start the exercise initialization process by clicking on the START button.	A display appears showing the exercise number, the MCC role, and the terrain to be used in the exercise.	<input checked="" type="checkbox"/> S <input type="checkbox"/> SA <input type="checkbox"/> U
1170	Verify that the MCC is participating in Exercise 1.	The MCC is participating in Exercise 1.	<input checked="" type="checkbox"/> S <input type="checkbox"/> SA <input type="checkbox"/> U
1180	Select the default role of the MCC to be US.	The display shows the default MCC role to be US.	<input checked="" type="checkbox"/> S <input type="checkbox"/> SA <input type="checkbox"/> U
1190	Verify that the terrain to be used for the exercise is Fort Knox 8/14/90, SW corner: ES450550, NE corner: FT200050 Go to the NEXT menu.	An Overview menu is displayed showing the following selectable options: Simulator Allocation Simulator Activation Command Post Initialization Service Element Initialization Battlemaster	<input checked="" type="checkbox"/> S <input type="checkbox"/> SA <input type="checkbox"/> U

5.2.16 Set Up the RWA Simulator as a AH-1 - The steps in this subparagraph consist of instructions for initializing a Fully Reconfigurable Device (FRED) as an AH-1.

<u>Step</u>	<u>Operator/System Action</u>	<u>Expected Result</u>	<u>Status</u> (Check One)
1200	Select the Simulator Allocation Option and GO to the next menu.	A display appears showing the simulators available for allocation, including one or more FRED simulators.	<input checked="" type="checkbox"/> S <input type="checkbox"/> SA <input type="checkbox"/> U
1210	Highlight the 8B FRED entry and click on the ALLOCATE button.	A display appears allowing entity assignment.	<input checked="" type="checkbox"/> S <input type="checkbox"/> SA <input type="checkbox"/> U

- | | | |
|------------------------------------------------------------------------------------------------------------------------------------------------------------------------------|-------------------------------------------------------------------------------------------------------------------------------------------------------|----------------------------------------------------------------------------------------------|
| 1220 Assign the entity to A Company by double clicking on US Army, then 223rd Attack Helo Battalion, then A Company. | The display shows the entity to be assigned to A Company. | <input checked="" type="checkbox"/> S <input type="checkbox"/> SA <input type="checkbox"/> U |
| 1230 Click on the ASSIGN button. | A display appears showing the simulators available for activation, including 8B FRED which is now shown as assigned to A Company, but not yet placed. | <input checked="" type="checkbox"/> S <input type="checkbox"/> SA <input type="checkbox"/> U |
| 1240 Click on the Overview button. | The Overview menu is displayed. | <input checked="" type="checkbox"/> S <input type="checkbox"/> SA <input type="checkbox"/> U |
| 1250 Select the Simulator Activation Option and GO to the next menu. | A display appears allowing simulator activation. | <input checked="" type="checkbox"/> S <input type="checkbox"/> SA <input type="checkbox"/> U |
| 1260 Activate the simulator in A Company by double clicking on US Army, then 223rd Attack Helo Battalion, then A Company. | The display shows the simulator to be activated in A Company. | <input checked="" type="checkbox"/> S <input type="checkbox"/> SA <input type="checkbox"/> U |
| 1270 Set a default location of FS085902 and verify that the default force is US. Go to the NEXT menu. | A display appears showing the activated simulators, 8B FRED is assigned to A Company, but not yet placed. | <input checked="" type="checkbox"/> S <input type="checkbox"/> SA <input type="checkbox"/> U |
| 1280 Highlight the 8B FRED entry by clicking on the entry and go to the NEXT menu. | A display appears allowing simulator customization. | <input checked="" type="checkbox"/> S <input type="checkbox"/> SA <input type="checkbox"/> U |
| 1290 Customize 8B FRED with a tail number of 2, a location of FS085902, a heading of 0 degrees, an alignment of US, a maintenance status of New, and a vehicle type of AH-1. | The display reflects the custom selections. | <input checked="" type="checkbox"/> S <input type="checkbox"/> SA <input type="checkbox"/> U |
| 1300 Verify that the default weapons load is:
20 mm Gatling: 750 Rounds
Stinger: 4
TOW: 8
Hydra 70 10 lb: 0
Hydra 70 MPSM: 38
Hydra 70 Flechette: 0 | The display reflects the custom selections and a default weapons load. | <input checked="" type="checkbox"/> S <input type="checkbox"/> SA <input type="checkbox"/> U |
| 1310 Verify that the default fuel load is: 1703 lbs. | The display reflects the custom selections and a default fuel load. | <input checked="" type="checkbox"/> S <input type="checkbox"/> SA <input type="checkbox"/> U |

1320 Select the ACTIVATE button.

A display appears showing the activated simulators. 8B FRED is assigned to A Company, placed. The RWA is activated as an AH-1, the image generator visuals and sound come on. No message indicating that the weapons model file (MS_TW_CH.D) could not be opened is output to the GT-111 system console. (See Section 5.2.5.) The flight and weapons models are initialized using the data files. The flight model is idle, standing by for input from the pilot.

S SA U

- 3.2.1.3.1.1
- 3.2.1.3.1.1.1.1
- 3.2.1.3.1.2
- 3.2.1.3.1.2.1.1
- 3.2.1.3.1.3
- 3.2.1.3.1.3.1.1
- 3.2.1.3.2
- 3.2.1.3.2.1
- 3.2.1.5.1
- 3.2.1.5.1.1.1
- 3.2.1.5.1.1.3
- 3.2.1.5.1.1.5
- 3.2.1.5.1.2.1
- 3.2.1.5.1.2.2
- 3.2.1.5.1.2.3
- 3.2.1.3.2.1.4

1330 Click on the Overview button.

The Overview menu is displayed.

S SA U

5.2.17 Set Up Targets - The steps in this subparagraph consist of instructions for initializing Gunnery Targets.

<u>Step</u>	<u>Operator/System Action</u>	<u>Expected Result</u>	<u>Status</u> (Check One)
1340	Select the Battlemaster Functions Option and GO to the next menu.	A display appears requesting the Battlemaster password.	<input checked="" type="checkbox"/> S <input type="checkbox"/> SA <input type="checkbox"/> U
1350	Enter the Battlemaster password (foozball) and click on the OK button.	The Battlemaster Overview menu is displayed showing the following selectable options: Displacement Reconstitute Gunnery Target's Resume Initialization End Exercise	<input checked="" type="checkbox"/> S <input type="checkbox"/> SA <input type="checkbox"/> U
1360	Select the Gunnery Targets Option and GO to the next menu.	A display allowing Gunnery Target Specification appears.	<input checked="" type="checkbox"/> S <input type="checkbox"/> SA <input type="checkbox"/> U
1370	Enter the gunnery targets as: Target 1, US, FWA, ES94808550, 2435 Target 2, US, FWA, ES94938510, 2435 Target 3, US, FWA, ES95108460, 2435 Target 4, US, FWA, ES95238420, 2435 and click on the Overview button.	The Battlemaster Overview menu is displayed.	<input checked="" type="checkbox"/> S <input type="checkbox"/> SA <input type="checkbox"/> U

5.2.18 Fly Aircraft Through Flight Envelope Phases - The steps in this subparagraph consist of instructions for flying the aircraft through the following flight envelope phases: Ascent, Hover, Cruise, Descent and Low Level Flight.

<u>Step</u>	<u>Operator/System Action</u>	<u>Expected Result</u>	<u>Status</u> (Check One)
1380	At the AH-1 softpanel, enter a waypoint at ES979898, and select it for navigation.	The Situational Display shows a 1 indicating the waypoint position relative to the aircraft's current location and heading (represented by the center crosshairs). It also identifies the aircraft's current position (grid coordinates FS085902), the bearing to the waypoint (approx. 267 deg.) and the range to the waypoint (approx. 10608 m.).	<input checked="" type="checkbox"/> S <input type="checkbox"/> SA <input type="checkbox"/> U

1390 Record the amount of fuel and the current time:

Fuel: 1690 lbs.
Time: 3:14

The fuel level is displayed on the Instructional Display.

S SA U

1400 Take off noting the torque at the point of liftoff. Ascend to an altitude of 1000 ft. above sea level and hover.

Torque: 88

Enter the torque as the Takeoff 2 Torque value in Step ~~1886~~ ₁₄₁₀

The aircraft ascent is representative of the data in the flight model data files and the system responds in real-time to the pilot's input.

S SA U

1410 Compare the torque required for this takeoff against the torque required for the first take off.

Takeoff 1 Torque: 68
Takeoff 2 Torque: 88

The torque required for the second takeoff is larger due to the increased ordnance mass.

S SA U

1420 Hover at 1000 ft. above sea level for one minute.

The aircraft hover is representative of the data in the flight model data files and the system responds in real-time to the pilot's input.

S SA U

1430 Fly at a constant cruise speed of approximately 100 knots with a heading of approximately 267 degrees till you reach the waypoint area (3 - 4 minutes).

The aircraft cruise is representative of the data in the flight model data files and the system responds in real-time to the pilot's input.

S SA U

1440 Descend to an altitude of 35 - 45 ft. above ground level and hover.

The aircraft descent is representative of the data in the flight model data files and the system responds in real-time to the pilot's input.

S SA U

1450 At the AH-1 softpanel, enter a waypoint at ES948855, and select it for navigation.

The Situational Display shows a 2 indicating the waypoint position relative to the aircraft's current location and heading.

S SA U

1460 Fly at a speed of 50 knots and at a constant altitude of 35 - 45 ft. above ground level at a heading of approximately 206 degrees until the target area is approximately 1250 meters away. Hover at an altitude of approximately 300 ft.

The aircraft's low level flight is representative of the data in the flight model data files and the system responds in real-time to the pilot's input.
•3.2.1.3.2.2

S SA U

5.2.19 Fire on the Targets and Land - The steps in this subparagraph consist of instructions for firing on the targets and landing the aircraft.

<u>Step</u>	<u>Operator/System Action</u>	<u>Expected Result</u>	<u>Status</u> (Check One)
1470	At the AH-1 Pilot Station, keeping the nose of the aircraft level with the horizon, select the 20 mm Gatling Gun (ballistics rounds) for firing by pushing up on the weapons action switch.	The Pilot's 20 mm gun selection light transitions from unlit to lit.	<input checked="" type="checkbox"/> S <input type="checkbox"/> SA <input type="checkbox"/> U
1480	Fire the gun expending approximately 20 - 30 rounds. Note the trajectory of flight for the fired rounds.	The rounds fly out in a manner representative of the data in the weapons model files.	<input checked="" type="checkbox"/> S <input type="checkbox"/> SA <input type="checkbox"/> U
		<p style="text-align: center;">Y Y Y Y Y Y Y Y</p> <p style="text-align: center;">* * *</p> <p style="text-align: center;">←————— Line of sight —————→</p>	
1490	Deselect the Gatling Gun by pushing up on the weapons action switch.	The Pilot's 20 mm gun selection light transitions from lit to unlit.	<input checked="" type="checkbox"/> S <input type="checkbox"/> SA <input type="checkbox"/> U
1500	At the AH-1 Co-Pilot/Gunner Station, select the Stinger Missile (ballistic missile) for firing by pushing down on the weapons action switch.	The Co-Pilots Stinger selection light transitions from unlit to lit.	<input checked="" type="checkbox"/> S <input type="checkbox"/> SA <input type="checkbox"/> U
1510	Use the Manual Tracker to track one of the targets until the target is within the bounds of the dashed box of the line of sight reticle.	The target is within the bounds of the line of sight reticle.	<input checked="" type="checkbox"/> S <input type="checkbox"/> SA <input type="checkbox"/> U
1520	Pull the trigger to the first detent.	An aural seek tone is heard.	<input checked="" type="checkbox"/> S <input type="checkbox"/> SA <input type="checkbox"/> U

- | | | | | |
|---------------------------------------------------------------------------------------------------------------------------------------------------------|---------------------------------------------------------------------------------------------------|------------------------------------------|--------------------------------|-------------------------------|
| 1530 At the AH-1 Pilot Position, maneuver the aircraft into Stinger prelaunch constraints. | When the aircraft is positioned within the +/- 45 degree constraints missile lock-on is achieved. | <input checked="" type="checkbox"/>
S | <input type="checkbox"/>
SA | <input type="checkbox"/>
U |
| 1540 At the AH-1 Co-Pilot/Gunner Position, fire on the target by pulling the weapons trigger switch to the second detent. | The missile is launched, flies towards the target and impacts.
•3.2.1.5.2.4.3 | <input checked="" type="checkbox"/>
S | <input type="checkbox"/>
SA | <input type="checkbox"/>
U |
| 1550 Deselect the Stinger by pushing up on the weapons action switch. | The Co-Pilot's Stinger selection light transitions from lit to unlit. | <input checked="" type="checkbox"/>
S | <input type="checkbox"/>
SA | <input type="checkbox"/>
U |
| 1560 At the AH-1 Co-Pilot/Gunner Station, select the TOW Missile (guided missile) for firing by pushing towards the right on the weapons action switch. | The Co-Pilots TOW selection light transitions from unlit to lit. | <input checked="" type="checkbox"/>
S | <input type="checkbox"/>
SA | <input type="checkbox"/>
U |
| 1570 Use the Manual Tracker to track one of the targets until the target is within the bounds of the dashed box of the line of sight reticle. | The target is within the bounds of the line of sight reticle. | <input checked="" type="checkbox"/>
S | <input type="checkbox"/>
SA | <input type="checkbox"/>
U |
| 1580 At the AH-1 Pilot Position, maneuver the aircraft into TOW prelaunch constraints. | When the aircraft is positioned within the constraints missile lock-on is achieved. | <input checked="" type="checkbox"/>
S | <input type="checkbox"/>
SA | <input type="checkbox"/>
U |
| 1590 At the AH-1 Co-Pilot/Gunner Position, fire on the target by pulling in the weapons trigger switch. | The missile is launched, flies briefly and disappears, no impact is seen.
•3.2.1.5.2.4.1 | <input checked="" type="checkbox"/>
S | <input type="checkbox"/>
SA | <input type="checkbox"/>
U |
| 1600 Deselect the TOW by pushing towards the right on the weapons action switch. | The Co-Pilot's TOW selection light transitions from lit to unlit. | <input checked="" type="checkbox"/>
S | <input type="checkbox"/>
SA | <input type="checkbox"/>
U |
| 1610 At the AH-1 Pilot Station, land the aircraft. | The aircraft lands and the flight modeling is stopped.
•3.2.1.3.2.3.2 | <input checked="" type="checkbox"/>
S | <input type="checkbox"/>
SA | <input type="checkbox"/>
U |
| 1620 Record the current fuel level and | The fuel level is available from the | <input checked="" type="checkbox"/>
S | <input type="checkbox"/> | <input type="checkbox"/> |

the current time:

Instructional Display.

S SA U

Fuel Level: 300 lbs.
Time: 3:39

Compute the fuel rate over time:

Fuel Consumption Rate: 66
lbs./min.

Pass 1 Fuel Rate:
Pass 2 Fuel Rate:

1630 Compare the fuel consumption rate during this pass against that obtained from pass 1.

The fuel consumption rate for pass 2 is approximately 5 times the fuel consumption rate for pass 1.

S SA U

5.2.20 Terminate the Exercise - The steps in this subparagraph consist of instructions for terminating the exercise.

<u>Step</u>	<u>Operator/System Action</u>	<u>Expected Result</u>	<u>Status</u> (Check One)		
1640	At the AIRNET SCC, select the End Exercise option and GO to the next menu.	An End Exercise Confirmation Menu is displayed.	<input checked="" type="checkbox"/> S	<input type="checkbox"/> SA	<input type="checkbox"/> U
1650	Respond to the Confirmation Question by clicking on YES.	The Confirmation Display disappears and the display returns to the Macintosh windows screen. The SCC disk is ejected and the CIG visuals and sound are terminated.	<input checked="" type="checkbox"/> S	<input type="checkbox"/> SA	<input type="checkbox"/> U
1660	At the GT-111 system console, verify that the simulation software is terminated.	The GT-111 system console displays CIG stop messages followed by the message: SIMULATOR STOPPED •3.2.1.3.3 •3.2.1.3.3.a •3.2.1.3.4 •3.2.1.3.4.a	<input checked="" type="checkbox"/> S	<input type="checkbox"/> SA	<input type="checkbox"/> U

Restore the modified files
 ms_tw_cs.d
 ms_st_ch.d
 m789.d
 rwa_aero.d
 rwa_engn.d
 to their baselined state.

6.0 NOTES

Test failures will be noted in the procedure against each test step as necessary where test results do not agree with expected results. Due to the nature of these system level tests, a simulator "crash" due to pilot error will not be constituted as a failure but an acceptable interruption. The system provides the capability for re-starting at the point of where the crash occurred and will be utilized during the execution of this system level test.

7.0 Test Failures/Interruptions

NOTE ANY FAILURES ENCOUNTERED DURING THE TEST IN THIS SECTION.

NO.	FAILURE/INTERRUPTION DESCRIPTION

8.0 Glossary

Admin./Log	Administration/Logistics
ADPS	Address
AIRNET	Aircraft Simulation Network
ALOC	Administration/Logistics Operations Console
Ammo	Ammunition
BBN	Bolt, Beranek, and Newman
CECI	Communications and Electronics Operations Instructions
CG	Computer Image Generator
CPG	Co-Pilot/Gunner
DMCC	Digital Message Communications Console
DMS	Digital Message Server
ETA	Estimated Time of Arrival
FRED	Fully Reconfigurable Device
FREE TXT	Free Text
FSE	Fire Support Element
FWD	Forward
GT-111	BBN Computer System/CIG supporting Simulation
HEI	High Explosive Incendiary
HUMMV	High Mobility Multi-Wheeled Vehicle
I & T	Integration & Test
IMMED	Immediately
lbs.	pounds
LCTN	Location
Mac	Macintosh Computer
MCC	Management, Command and Control Console
MIPS	AIRNET MCC Host Computer
MOV TO	Move To
MOV CMD	Move Command
MSG	Message
MSGS	Messages
MTO	Movement to Order
PDU	Protocol Data Unit
PIE	Pyrotechnic Incendiary Explosive
RAH-66	Comanche Helicopter
RECON	Reconnaissance
RECON TYPE	Reconnaissance Type
REQT	Request
RPRT	Report
RWA	Rotary Wing Aircraft
S/W	Software
SOC	System Control Console
SDF	System Development Facility, Loral WDL, San Jose
SIMNET	Simulation Network
SND ROUT	Send Routine
SND URG	Send Urgent
SYS MAIN	System Main Menu
TCC	Tactical Operations Center
UMCP	Unit Maintenance Collection Point
UTM	Universal Transverse Mercator
WDL	Western Development Labs

WHN RDY
XMIT ALT
XMIT LCN

When Ready
Transmit Altitude
Transmit Location

APPENDIX A

EXERCISE "B" REQUIREMENTS MATRIX

REQ NO.	TITLE	REQUIREMENT
3.2.1.3.1	Flight Model Initialization State.	The Flight Model Segment Initialization State shall be entered during the System Initialization process after system bootup. System state and status variables uniquely identify the RWA AirNet configuration and state.
3.2.1.3.1.1	Flight Controls Initialization.	Initialization of the Flight Controls Model Sub-Segment configuration shall be done during this state upon command from the system.
3.2.1.3.1.1.1	Flight Controls Data	Parameters to be set shall include maximum pitch, roll and yaw rates, turning radius, flight controls input sensitivity and profile, physical constants, conversion factors, integration constants, gains and limits.
3.2.1.3.1.1.1.1	Flight Controls Data File.	Data values shall be read from a flight controls model initialization file.
3.2.1.3.1.1.1.2	Flight Controls Data Format	The format of the data file shall allow modification of the data using a text editor.
3.2.1.3.1.2	Flight Dynamics Initialization.	Initialization of the Flight Dynamics Model Sub-Segment configuration shall be done during this state upon command from the system. During this mode, configuration flags and variables are set which point to specific submodules and data files for execution and loading.
3.2.1.3.1.2.1	Flight Dynamics Data	Initialization shall include downloading of coefficient tables for the main rotor, fuselage and stabilizers.
3.2.1.3.1.2.1.1	Flight Dynamics Data File.	These values shall be read from a flight dynamics model initialization file.
3.2.1.3.1.2.1.2	Flight Dynamics Data Format	The format of the data file shall allow modification of the data using a text editor.
3.2.1.3.1.3	Engine Initialization.	Initialization of the Engine Model Sub-Segment configuration shall be done during this state upon command from the system.
3.2.1.3.1.3.1	Engine Initialization	Initialization shall include downloading of data tables for the gas and power turbines, fuel consumption, power output, and acceleration coefficients.
3.2.1.3.1.3.1.1	Engine Data.	These values shall be read from an engine model initialization file.
3.2.1.3.1.3.1.2	Engine Data Format	The format of the data file shall allow modification of the data using a text editor.
3.2.1.3.2	Flight Model Run-Time State.	In this mode the Flight model Segment shall be in stand-by awaiting RWA AirNet Flight model activity.
3.2.1.3.2.1	Flight Model Idle Mode.	During the Flight Model Idle mode, the execution of the flight model functions shall be suspended.
3.2.1.3.2.1.2	Flight Model Idle Mode Change.	Execution shall be started or resumed from this mode.

REQ NO.	TITLE	REQUIREMENT
3.2.1.3.2.1.4	Flight Model Idle Mode Functionality.	The modifications shall have no adverse affects upon the Flight Model Idle mode functionality.
3.2.1.3.2.2	Flight Model Execute Mode.	During the Flight Model Execution mode, the flight model shall be executed in real-time.
3.2.1.3.2.2.3	Flight Model Execute Mode Data Sources.	The source of coefficient data shall be table look ups.
3.2.1.3.2.2.4	Flight Model Execute Mode Functionality.	The modifications shall have no adverse affects upon the Flight Model Execute mode functionality.
3.2.1.3.2.2.5	Flight Controls Model	The Flight Controls Model Sub-Segment shall simulate the flight controls of the aircraft.
3.2.1.3.2.2.6	Flight Dynamics Model	The Flight Dynamics Model Sub-Segment shall provide a simulation of the flight characteristics of the aircraft.
3.2.1.3.2.2.6.b	Flight Dynamics Model	The simulation shall include portions of the flight envelope including cruise, ascent, descent, hover, and low-level flight with ground effect.
3.2.1.3.2.3.2	Flight Model Stop Mode Functionality.	The modifications shall have no adverse affects upon the Flight Model Stop mode functionality.
3.2.1.3.3	Segment Capability Relationships.	Flight Model Segment capability relationships shall not be affected by modifications and restructuring of the flight model functions.
3.2.1.3.3.a	Segment Capability Relationships.	The capability relationships shall remain intact.
3.2.1.3.4	Segment External Interface Requirements.	Flight Model Segment interface requirements shall not be affected by modifications and restructuring of the flight model functions.
3.2.1.3.4.a	Segment External Interface Requirements.	The interface requirements shall remain intact.
3.2.1.5	RWA Weapons Model Upgrade Segment	The intent of the RWA Weapons Model Upgrade is to improve the software by making it table driven.
3.2.1.5.1	Initialize Weapons State	The Initialize Weapons Segment state is entered during the System Initialization process after system bootup.
3.2.1.5.1.1.1	Guided Missile Trajectory Coefficient Data	Trajectory coefficient data associated with guided missiles shall be loaded at mission initialization.
3.2.1.5.1.1.2	Guided Missile Trajectory Coefficient Data Format	Trajectory coefficient data files for Guided Missiles shall be in a format which allow modification through a standard text editor.
3.2.1.5.1.1.3	Ballistic Missiles Trajectory Coefficient Data	Trajectory coefficient data associated with ballistic missiles shall be loaded at mission initialization.
3.2.1.5.1.1.4	Ballistic Missile Trajectory Coefficient Data Format	Trajectory coefficient data files for Ballistic Missiles shall be in a format which allow modification through a standard text editor.
3.2.1.5.1.1.5	Ballistic Rounds Trajectory Coefficient Data	Trajectory coefficient data associated with Ballistic Rounds shall be loaded at mission initialization.

REQ NO.	TITLE	REQUIREMENT
3.2.1.5.1.1.6	Ballistic Rounds Trajectory Coefficient Data Format	Trajectory coefficient data files for Ballistic Rounds shall be in a format which allow modification through a standard text editor.
3.2.1.5.1.2.1	Guided Missiles Characterization	Guided missile characteristics shall be initialized via data files.
3.2.1.5.1.2.2	Ballistic Missiles Characterization	Ballistic missile characteristics shall be initialized via data files.
3.2.1.5.1.2.3	Ballistic Rounds Characterization	Ballistic Rounds characteristics shall be initialized via data files.
3.2.1.5.2.4.1	Guided Missile Flyout	Guided Missile Flyout shall utilize new data structures containing trajectory and control data.
3.2.1.5.2.4.3	Ballistic Missile Flyout	Ballistic Missile Flyout shall utilize new data structures containing trajectory and control data.
3.2.1.5.2.4.4	Ballistic Round Flyout	Ballistic Round Flyout shall utilize new data structures containing trajectory and control data.

Appendix B

Exercise "B" Requirements Inspection/Analysis Matrix

REQ NO.	TITLE	REQUIREMENT	Report Reference
3.2.1.3.2.1.1	Flight Model Idle Mode Integration.	Integration computations shall be put in a stable state.	1
3.2.1.3.2.1.3	Flight Model Idle Mode Control.	This mode shall be controlled by the system executive.	1
3.2.1.3.2.2.1	Flight Model Execute Mode Execution.	Execution shall be stopped from this mode.	1
3.2.1.3.2.2.2	Flight Model Execute Mode Execution Rate.	The rate of execution shall be controlled by the system executive.	1
3.2.1.3.2.2.5.a	Flight Controls Model	Input shall be used to calculate a resultant movement of a control surface and corresponding output to the flight dynamics model sub-segment.	2
3.2.1.3.2.2.6.c	Flight Dynamics Model	The simulation shall include calculation of forces and moments, equations of motion, weight and balance, and aerodynamics.	3
3.2.1.3.2.2.7	Engine Model	The Engine Model Sub-Segment shall provide core engine representation, torque generation, engine fuel system utilization, and transmission representation.	4
3.2.1.3.2.3	Flight Model Stop Mode.	During the Flight Model Stop mode, the execution of the flight model functions shall be suspended.	1
3.2.1.3.2.3.1	Flight Model Stop Mode Control.	This mode shall be controlled by the system executive.	1
3.2.1.5.2.4.2	Use of Data Tables	Updates required Modification of the source code shall be limited to reference data tables containing data which is read in via data files.	5
3.9.3	RWA Flight Model Upgrade Segment Qualification	The RWA Flight Model Upgrade Segment shall be qualification tested at Ft. Rucker.	6
3.9.3.a	RWA Flight Model Upgrade Segment Qualification	The RWA Flight Model Upgrade Segment test shall take place during the program integration and test phase (I&T).	6

REQ NO.	TITLE	REQUIREMENT	Report Reference
3.9.3.b	RWA Flight Model Upgrade Segment Qualification	The RWA Flight Model Upgrade Segment test shall not exceed 2 working days.	6
3.9.3.c	RWA Flight Model Upgrade Segment Qualification	The testing shall demonstrate the RWA Flight Model Upgrade Segment provides the functionality described previously in this document.	6
3.9.5	RWA Weapons Model Upgrade Segment Qualification	The RWA Weapons Model Upgrade Segment shall be qualification tested at Ft. Rucker.	6
3.9.5.a	RWA Weapons Model Upgrade Segment Qualification	The RWA Weapons Model Upgrade Segment test shall take place during the program integration and test phase (I&T).	6
3.9.5.b	RWA Weapons Model Upgrade Segment Qualification	The RWA Weapons Model Upgrade Segment test shall not exceed 2 working days.	6
3.9.5.c	RWA Weapons Model Upgrade Segment Qualification	The testing shall demonstrate the RWA Weapons Model Upgrade Segment provides the functionality described previously in this document.	6

Appendix C

Exercise "B" Inspection/Analysis Reports

Report Reference

1. Flight Model Mode Requirements
2. Flight Controls Requirements
3. Flight Dynamics Requirements
4. Engine Model Requirements
5. Data Table Use
6. Flight and Weapons Models Qualification Requirements
7. Processing Capacity

AIRNET INSPECTION/ANALYSIS REPORT 1

Req. No.:	3.2.1.3.2.1.1	Spec. Para.:	3.2.1.3.2.1.1
	3.2.1.3.2.1.3		3.2.1.3.2.1.3
	3.2.1.3.2.2.1		3.2.1.3.2.2.1
	3.2.1.3.2.2.2		3.2.1.3.2.2.2
	3.2.1.3.2.3		3.2.1.3.2.3
	3.2.1.3.2.3.1		3.2.1.3.2.3.1

Requirement Descriptions:

3.2.1.3.2.1.1 Flight Model Idle Mode Integration
Integration computations shall be put in a stable state.

3.2.1.3.2.1.3 Flight Model Idle Mode Control
This mode shall be controlled by the system executive.

3.2.1.3.2.2.1 Flight Model Execute Mode Execution
Execution shall be stopped from this mode.

3.2.1.3.2.2.2 Flight Model Execute Mode Execution Rate
The rate of execution shall be controlled by the system executive.

3.2.1.3.2.3 Flight Model Stop Mode
During the Flight Model Stop mode, the execution of the flight model functions shall be suspended.

3.2.1.3.2.3.1 Flight Model Stop Mode Control
This mode shall be controlled by the system executive.

Inspection Method: The flight model simulation is dependent upon the initialization of the flight model itself, and the input of data affecting the state of the aircraft. Figure 1 illustrates the software path related to flight model execution.

The system executive (main) program controls all execution. When the software is first initiated, it performs preliminary initialization based upon defaults and user specified run parameters. Ultimately, it invokes the simulation_state_machine. This software is executed throughout the simulation at a real-time rate.

The simulation_state_machine software controls the execution of multiple processes whose sequence and rate of execution is determined by the simulation state (3.2.1.3.2.2.2). Execution passes through veh_spec_startup, veh_spec_idle and veh_spec_init which perform further initialization and set up (including placing the integration computations in a stable state, 3.2.1.3.2.1.1) based upon the type of vehicle to be simulated. When complete, the flight model segment has been initialized and transitions from an initialization state to a run-time state. It then stands by in an idle mode awaiting activity (3.2.1.3.2.1.3).

When the simulation state is SIM_SIMULATE_STATE, the veh_spec_simulate software is initiated. This further invokes various routines which perform the simulation of the aircraft including its flight; the flight model segment is in execute mode. The system remains in this state/mode until the simulation state transitions to SIM_SIMSTOP_STATE. Once transitioned to this state, simulation of

the aircraft's flight is terminated (flight model stop mode, 3.2.1.3.2.2.1) and the simulation state is returned to SIM_STATE_IDLE (3.2.1.3.2.3, 3.2.1.3.2.3.1)

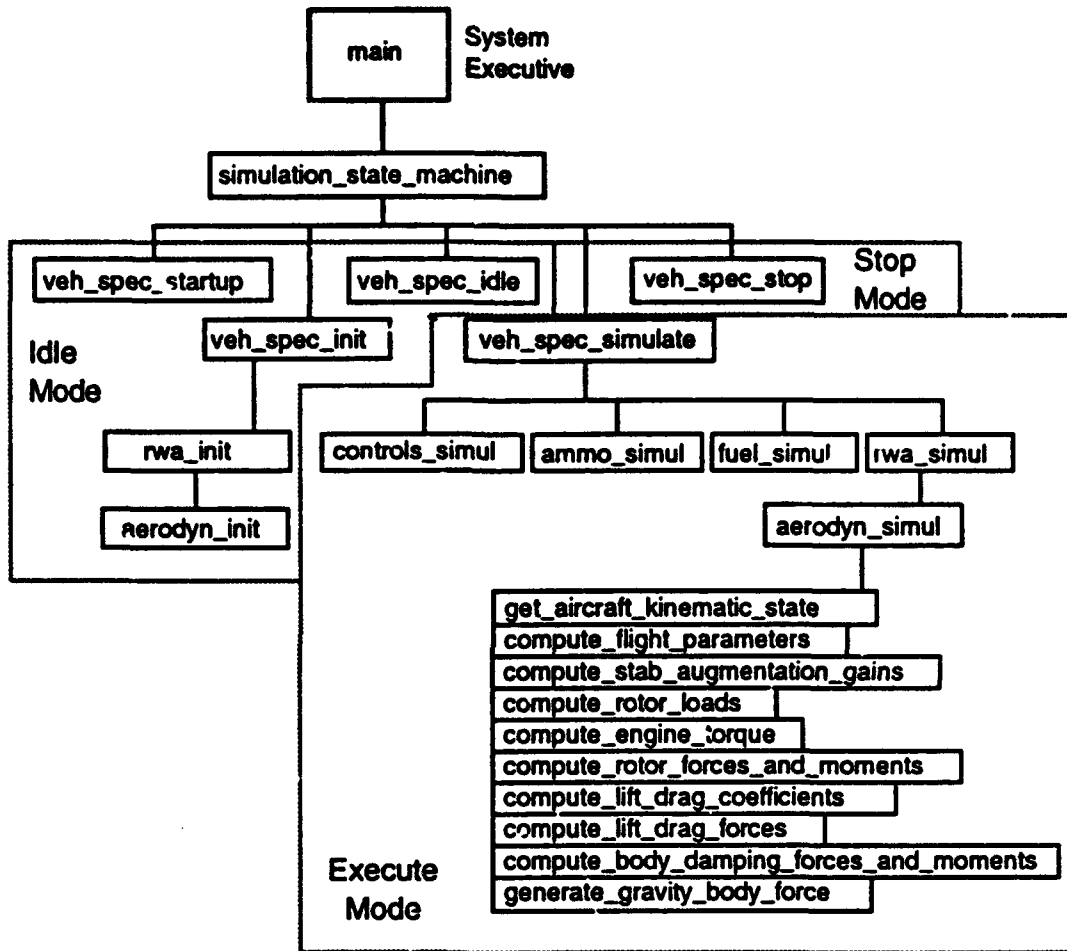

Figure 1: Flight Model Execution Software Path

The software packages containing the software referenced above are as follows:

Software Package	Software Module
rwa_main.c	main veh_spec_startup veh_spec_idle veh_spec_init veh_spec_simulate veh_spec_stop
libmain/main.c	simulation_state_machine
rwa_ctl_fsm.c	controls_simul
rwa_ammo.c	ammo_simul
rwa_fuelsys.c	fuel_simul
rwa_simul.c	rwa_simul
rwa_aerodyn.c	aerodyn_simul get_aircraft_kinematic_state compute_flight_parameters compute_stab_augmentation_gains compute_rotor_loads compute_engine_torque compute_rotor_forces_and_moments compute_lift_drag_coefficients compute_lift_drag_forces compute_body_damping_forces_and_moments generate_gravity_body_force

The referenced software packages can be reviewed and inspected for validation of these requirements.

VERIFIED: _____

TITLE: _____

CONCURRENCE: _____

AIRNET INSPECTION/ANALYSIS REPORT 2

Req. No.: 3.2.1.3.2.2.5.a

Spec. Para.: 3.2.1.3.2.2.5

Requirement Descriptions:

Req. No.: 3.2.1.3.2.2.5.a Flight Controls Model

Input shall be used to calculate a resultant movement of a control surface and corresponding output to the flight dynamics model sub-segment.

Inspection Method: The software package `rwa_aerodyn.c` contains the function used to read the flight model data files and initialize flight model parameters. The function, `aerodyn_init` reads data files: `rwa_aero.d`, `rw_ae_in.d`, `rw_ae_sp.d`, and `rw_ae_sl.d`.

Additionally, this software package contains the functions used in the execution of the flight model, including `aerodyn_simul` which makes several function calls including:

```

get_aircraft_kinematic_state
compute_flight_parameters
compute_stab_augmentation_gains
compute_rotor_loads
compute_engine_torque
compute_rotor_forces_and_moments
compute_lift_drag_coefficients
compute_lift_drag_forces
compute_body_damping_forces_and_moments
transform_lift_drag_forces_to_body_coordinates
generate_gravity_body_force
interact_with_ground
sum_body_forces_and_moments_about_ac
send_to_dynamics_kinematics

```

Function `send_to_dynamics_kinematics` makes three function calls:

```

vehicle_mass_init (vehicle_mass, inertia_matrix)
vehicle_forces (force_body)
vehicle_torques (moment_bcdy)

```

The parameter `force_body`, passed to `vehicle_forces`, is derived using values taken from the flight model data files and forces and moments derived from the resultant movement of control surfaces. `Force_body` is a vector whose value is determined by summing the forces on the aircraft body (the summing is done by procedure `sum_body_forces_and_moments_about_ac`). The following values are summed:

```

force_body_main_rotor
lift_body_virtual_wing
lift_body_virtual_stab
drag_body
force_body_damping
gravity_force_body
ground_force
force_ground_effect

```

Table 1 identifies the function computing each of these values, and the flight model data values used. All flight model data values are from rwa_aero.d.

Table 1: Procedure to Data File Value Map

Procedure	Value	Data Table Value(s) Used in Computation
compute_rotor_forces_and_moments	force_body_main_rotor	MAIN_ROTOR_MAST_TILT TAIL_ROTOR_MAX_THRUST MAIN_ROTOR_MAX_THRUST HOVER_AUG_CLIMB_P_GAIN HOVER_AUG_CLIMB_I_GAIN HOVER_AUG_YAW_P_GAIN HOVER_AUG_YAW_I_GAIN
transform_lift_drag_forces_to_body_coordinates	lift_body_virtual_wing	VIRTUAL_WING_AREA LIFT_COEFF_VIRTUAL_WING WING_STALL_AOA WING_LIFT_COEFFICIENT_FIT_0 WING_LIFT_COEFFICIENT_FIT_1 WING_LIFT_COEFFICIENT_FIT_2 WING_LIFT_COEFFICIENT_FIT_3
transform_lift_drag_forces_to_body_coordinates	lift_body_vstab	VSTAB_AREA VSTAB_STALL_SSA VSTAB_LIFT_COEFFICIENT_1
transform_lift_drag_forces_to_body_coordinates	drag_body	P_DRAG_TAS_BREAK TOTAL_WETTED_SURFACE_AREA INDUCED_DRAG_COEFF P_DRAG_COEFF_CONST P_DRAG_COEFF_BREAK P_DRAG_TAS_MAX P_DRAG_COEFF_MAX
compute_body_damping_forces_and_moments	force_body_damping	LATERAL_VELOCITY_DAMPING_GAIN VERTICAL_RATE_DAMPING_GAIN
generate_gravity_body_force	gravity_force_body	AIRFRAME_MASS ORDNANCE_MASS GRAV_CONSTANT
interact_with_ground	ground_force	None
interact_with_ground	force_ground_effect	MAIN_ROTOR_GROUND_EFFECT_FACTOR

The referenced software packages can be reviewed and inspected for validation of this requirement.

VERIFIED: _____

TITLE: _____

CONCURRENCE: _____

AIRNET INSPECTION/ANALYSIS REPORT 3

Req. No.: 3.2.1.3.2.2.6.c

Spec. Para.: 3.2.1.3.2.2.6

Requirement Descriptions:

Req. No.: 3.2.1.3.2.2.6.c Flight Dynamics Model

The simulation shall include calculation of forces and moments, equations of motion, weight and balance and aerodynamics.

Inspection Method: The software packages rwa_aerodyn.c, rwa_kinemat.c libupdate/libupdate.c, libdyn/calc_inert.c and libdyn/calc_udot.c contain the functions which calculate forces and moments, equations of motion, weight and balance and aerodynamics. The related functions are:

rwa_aerodyn.c

Procedure	Description
get_aircraft_kinematic_state	Retrieves the kinematic state of the aircraft including its airspeed, altitude, velocity, gravitational direction vector, angle of attack, side slip angle, g force and vertical speed.
compute_flight_parameters	Computes the aircraft's flight parameters including: the ambient density, temperature and pressure of the air, the dynamic pressure, the pitch, roll and yaw rates, and the roll and pitch.
interact_with_ground	Computes the ground effect on the force.
compute_gross_weight	Computes the vehicle's mass and gross weight.
compute_lift_drag_forces	Computes the lift drag forces.
compute_body_damping_forces_and_moments	Computes the body damping forces and moments.
compute_lift_drag_coefficients	Computes the lift drag coefficients which are used by the procedure compute lift drag forces.
send_to_dynamics_kinematics	Calls dynamics/kinematics procedures: vehicle_mass_init (initializes the mass properties of the aircraft) vehicle_forces (sets the vehicle forces) vehicle_torques (sets the vehicle torques) These values are subsequently input to dynamics procedures which calculate acceleration, velocity, and position.
sum_body_forces_and_moments_about_ac	Computes the sum of all the forces and moments about the aircraft.
generate_gravity_body_force	Calls compute_gross_weight to get the vehicle's gross weight and then computes the gravitational force on the aircraft body.
compute_rotor_loads	Computes the main rotor load torque and the tail rotor load torque.
compute_engine_torque	Computes the engine torque.
compute_rotor_forces_and_moments	Computes the rotor forces and moments.
compute_stab_augmentation_gains	Computes the stabilizer augmentation gains.

rwa_kinemat.c

Procedure	Description
veh_spec_kinematics_simul	Determines vehicle specific kinematics.

libupdate/libupdate.c

Procedure	Description
vehicle_mass_init	Updates the vehicle mass
vehicle_update	Updates the vehicle's inertial forces, acceleration, and velocities. It calls dynamics_calc_inertial_forces and dynamics_calc_udot.

libdyn/calc_inert.c

Procedure	Description
dynamics_calc_inertial	Calculates gyroscopic torques and centrifugal forces.

libdyn/calc_udot.c

Procedure	Description
dynamics_calc_udot	Calculate new acceleration

The referenced software packages can be reviewed and inspected for validation of this requirement. Each of the referenced functions is unchanged from its original state (pre-data table use) with the exception of compute_lift_drag_coefficients which was modified to use data table values rather than hard-coded values.

VERIFIED: _____

TITLE: _____

CONCURRENCE: _____

AIRNET INSPECTION/ANALYSIS REPORT 4

Req. No.: 3.2.1.3.2.2.7

Spec. Para.: 3.2.1.3.2.2.7

Requirement Descriptions:

Req. No.: 3.2.1.3.2.2.7 Engine Model

The Engine Model Sub-Segment shall provide core engine representation, torque generation, engine fuel system utilization and transmission representation.

Inspection Method: The software package rwa_engine.c represents the Engine Model Sub-Segment. It contains functions which perform the simulation of the aircraft engine. The primary function is engine_simul.

The referenced software package can be reviewed and inspected for validity of this requirement.

VERIFIED: _____

TITLE: _____

CONCURRENCE: _____

AIRNET INSPECTION/ANALYSIS REPORT 5

Req. No.: 3.2.1.5.2.4.2

Spec. Para.: 3.2.1.5.2.4.2

Requirement Descriptions:

Req. No.: 3.2.1.5.2.4.2 Use of Data Tables

Modification of source code shall be limited to reference data tables containing data which is read in via data files.

Inspection Method: Comparison of the original source (miss_hellfr.c, miss_stinger.c, miss_tow.c, and rwa_hydra.c) against the updated source reveals that the modifications are limited to the reading of data files and the use of the data file parameters.

The referenced software packages and the attached difference files can be reviewed and inspected for validation of this requirement.

VERIFIED: _____

TITLE: _____

CONCURRENCE: _____

Difference file for miss_hellfr.c

```

1c1
< /* $Header: /a3/adst-cm/RWA/ATACII/libsrc/libmissile/RCS/miss_hellfr.c,v 1.1
1993/02/15 22:17:50 cm-adst Exp $ */
...
> /* $Header: /a3/adst-cm/RWA/ATACII/libsrc/libmissile/RCS/miss_hellfr.c,v 1.2
1993/04/06 19:12:50 cm-adst Exp $ */
3a4,6
> * Revision 1.2 1993/04/06 19:12:50 cm-adst
> * A. Au-Yeung's changes for spcr 124
> *
8c11
< static char RCS_ID[] = "$Header: /a3/adst-
cm/RWA/ATACII/libsrc/libmissile/RCS/miss_hellfr.c,v 1.1 1993/02/15 22:17:50 cm-adst
Exp $";
...
> static char RCS_ID[] = "$Header: /a3/adst-
cm/RWA/ATACII/libsrc/libmissile/RCS/miss_hellfr.c,v 1.2 1993/04/06 19:12:50 cm-adst
Exp $";
11c14
< static char rcsid [] = "$RCSfile: miss_hellfr.c,v $ $Revision: 1.1 $ $State: Exp $";
...
> static char rcsid [] = "$RCSfile: miss_hellfr.c,v $ $Revision: 1.2 $ $State: Exp $";
13,29d15
< /.....
< *
< * FILE:      miss_hellfr.c
< * AUTHOR:   Bryant Collard
< * MAINTAINER: Bryant Collard
< * PURPOSE:  This file contains routines which fly out a
< *           missile with the characteristics of a HELLFIRE
< *           missile.
< * HISTORY:  11/25/88 bryant: Creation
< *           4/24/89 bryant: Added static memory allocation
< *           08/07/90 bryant: NIU librv modifications.
< *           08/09/90 kris: corrected flight coefficients
< *
< * Copyright (c) 1988 BBN Systems and Technologies, Inc.
< * All rights reserved.
< *
< ...../

```

30a17,68

>
/.....
.....

> *
> * FILE: miss_hellfr.c
> * AUTHOR: Bryant Collard
> * MAINTAINER: Bryant Collard
> * PURPOSE: This file contains routines which fly out a
> * missile with the characteristics of a HELLFIRE
> * missile.
> * HISTORY: 11/25/88 bryant: Creation
> * 4/24/89 bryant: Added static memory allocation
> * 08/07/90 bryant: NIU libra modifications.
> * 08/09/90 kris: corrected flight coefficients
> * Copyright (c) 1988 BBN Systems and Technologies, Inc.
> * All rights reserved.

>
/.....
...../

>
/.....
.....

> * Revisions:
> *
> * Version Date Author Description SP/CR Number
> *
> * 1.2 03/25/93 A. Au-Yeung ported in all Airnet upgrades 124,31
> * rev1.4 of AIRNET miss_hellfr.c
> *
> *
/.....
...../

>
>

```

/.....
.....
>
> * SP/CR No.   Description of Modification
> * .....
> * .....
> * 124        Ainet upgrades
> *            Data File Initialization.
> *            Added pathname to data directory.
> *            Changed %l to %d
> *            Hard coded defines changed to array elements.
> *            Characteristics/parameter data array added.
> *            Degree of polynomial data array added.
> *            Added file reads for hellfire characteristics/
> *            parameters, burn speed coefficients, coast speed
> *            coefficients, and time-of-flight coefficients.
> *
> *            Added "/simnet/data/" to each data file pathname.
> *
> * 31         Increased the size of fgets to make sure the whole line is
> *            read in.
> *
> * .....
> * .....
>
>
>
> 49a88,96
> /*
> * Debug macro
> */
> #ifdef FILEDBG
> #define P(a)      a
> #else
> #define P(a)
> #endif
>
> 54,59c101,105
< #define HELLFIRE_ARM_TIME      20.0      /* ticks (1.3 sec) */
< #define HELLFIRE_BURNOUT_TIME  36.0      /* ticks (2.4 sec) */
< #define HELLFIRE_MAX_FLIGHT_TIME 540.0    /* ticks (36 sec) */
< #define SPEED_0      30.95953043 /*old 28.33333333*/ /*max_speed*/
< #define THETA_0      0.046542113 /*0.013962634*/
<
>
> #define HELLFIRE_ARM_TIME      hellfr_miss_char[ 0]
> #define HELLFIRE_BURNOUT_TIME  hellfr_miss_char[ 1]
> #define HELLFIRE_MAX_FLIGHT_TIME hellfr_miss_char[ 2]
> #define SPEED_0                hellfr_miss_char[ 3]
> #define THETA_0                hellfr_miss_char[ 4]

```

```

64,71c110,117
< #define SIN_UNGUIDE      0.069756474 /* 4 deg */
< #define COS_UNGUIDE      0.997564050
< #define SIN_CLIMB        0.004072424 /* 3.5 deg/sec */
< #define COS_CLIMB        0.999991708
< #define SIN_LOCK         0.156434465 /* 9 deg */
< #define COS_LOCK         0.987688341
< #define COS_TERM         0.241921896 /* 76 deg */
< #define COS_LOSE         0.939692621 /* 20 deg */
...
> #define SIN_UNGUIDE      hellfr_miss_char[ 5]
> #define COS_UNGUIDE      hellfr_miss_char[ 6]
> #define SIN_CLIMB        hellfr_miss_char[ 7]
> #define COS_CLIMB        hellfr_miss_char[ 8]
> #define SIN_LOCK         hellfr_miss_char[ 9]
> #define COS_LOCK         hellfr_miss_char[10]
> #define COS_TERM         hellfr_miss_char[11]
> #define COS_LOSE         hellfr_miss_char[12]
78,80c124,126
< #define HELLFIRE_TOF_DEG      4 /* Time Of Flight for a range. */
< #define HELLFIRE_BURN_SPEED_DEG 3 /* Speed before motor burnout. */
< #define HELLFIRE_COAST_SPEED_DEG 5 /* Speed after motor burnout. */
...
> #define HELLFIRE_TOF_DEG      hellfr_miss_poly_deg[ 0]
> #define HELLFIRE_BURN_SPEED_DEG hellfr_miss_poly_deg[ 1]
> #define HELLFIRE_COAST_SPEED_DEG hellfr_miss_poly_deg[ 2]
83c129
< * Coefficients for the TOF polynomial.
...
> * Hellfire missile characteristic parameters initialized to default values.
85c131
< static REAL hellfire_tof_coeff[HELLFIRE_TOF_DEG + 1] =
...
> static REAL hellfr_miss_char[15] =
87,91c133,147
< 18.0, /* a_0 tick /* 1.2 seconds */
< 3.1461916e-2, /* a_1 tick/meter */
< 3.1921274e-6, /* a_2 tick/meter^2 */
< 3.5260413e-10, /* a_3 tick/meter^3 */
< -2.8469594e-14 /* a_4 tick/meter^4 */
...

```

```

> 20.0,          /* ticks (1.3 sec) */
> 36.0,          /* ticks (2.4 sec) */
> 540.0,        /* ticks (36 sec) */
> 30.95953043,  /* max_speed      */
> 0.046542113,
> 0.069756474,  /* sin 4.0 deg    */
> 0.997564050,  /* cos 4.0 deg    */
> 0.004072424,  /* sin 3.5 deg    */
> 0.999991708,  /* cos 3.5 deg    */
> 0.156434465,  /* sin 9.0 deg    */
> 0.987688341,  /* cos 9.0 deg    */
> 0.241921896,  /* cos 76.0 deg   */
> 0.939692621,  /* cos 20.0 deg   */
> 0.0,
> 0.0
95c151
< * Coefficients for the speed polynomial before motor burnout.
...
> * Hellfire missile polynomial degree initialized to default values.
97c153
< static REAL hellfire_burn_speed_coeff[HELLFIRE_BURN_SPEED_DEG + 1] =
...
> static int hellfr_miss_poly_deg[ 3] =
99,102c155,157
< 2.0044395e-2, /* a_0 - meters */
< 6.7384206e-1, /* a_1 - m/tick */
< 9.8007701e-3, /* a_2 - m/tick^2 */
< -1.6782227e-4 /* a_3 - m/tick^3 */
...
> 4, /* tof poly degree */
> 3, /* burn speed poly degree */
> 5 /* coast speed poly degree */
106c161
< * Coefficients for the speed polynomial after motor burnout.
...
> * Coefficients for the TOF polynomial initialized to default values.
108c163
< static REAL hellfire_coast_speed_coeff[HELLFIRE_COAST_SPEED_DEG + 1] =
...
> static REAL hellfire_tof_coeff[10] =
109a165,200
> 18.0, /* a_0 tick */ /* 1.2 seconds */
> 3.1461816e-2, /* a_1 tick/meter */
> 3.1921274e-6, /* a_2 tick/meter^2 */
> 3.5260413e-10, /* a_3 tick/meter^3 */
> -2.8469594e-14, /* a_4 tick/meter^4 */
> 0.0, /* a_5 tick/meter^5 */
> 0.0, /* a_6 tick/meter^6 */
> 0.0, /* a_7 tick/meter^7 */
> 0.0, /* a_8 tick/meter^8 */
> 0.0 /* a_9 tick/meter^9 */
> );
>

```

```

> /*
> * Coefficients for the speed polynomial before motor burnout initialized to
> * default values.
> */
> static REAL hellfire_burn_speed_coeff[10] =
> {
>     2.0044395e-2, /* a_0 - meters */
>     6.7384206e-1, /* a_1 - m/tick */
>     9.8007701e-3, /* a_2 - m/tick^2 */
>     -1.6782227e-4, /* a_3 - m/tick^3 */
>     0.0, /* a_4 - m/tick^4 */
>     0.0, /* a_5 - m/tick^5 */
>     0.0, /* a_6 - m/tick^6 */
>     0.0, /* a_7 - m/tick^7 */
>     0.0, /* a_8 - m/tick^8 */
>     0.0 /* a_9 - m/tick^9 */
> };
>
> /*
> * Coefficients for the speed polynomial after motor burnout initialized to
> * default values.
> */
> static REAL hellfire_coast_speed_coeff[10] =
> {
115c206,210
<     -7.9542005e-12 /* a_5 - m/tick^5 */
- - -
>     -7.9542005e-12, /* a_5 - m/tick^5 */
>     0.0, /* a_6 - m/tick^6 */
>     0.0, /* a_7 - m/tick^7 */
>     0.0, /* a_8 - m/tick^8 */
>     0.0 /* a_9 - m/tick^9 */
143a239,369
>     int i;
>     int data_tmp_int;
>     float data_tmp;
>     char descript[80];
>     FILE *fp;
>
>     P(sprintf("$$$$ HELLFIRE missile file data $$$;\n"));
>
> /* DEFAULT CHARACTERISTIC DATA FOR miss_hellfr.c READ FROM FILE */
> fp = fopen("/simnet/data/ms_hf_ch.d","r");
> if(fp==NULL){
>     fprintf(stderr, "Cannot open /simnet/data/ms_hf_ch.d\n");
>     exit();
> }
>
> rewind(fp);
>
> /* Read array data */
> i=0;
>

```

```

> while(fscanf(fp,"%f", &data_tmp) != EOF)
> {
>     hellfr_miss_char[i] = data_tmp;
>     fgets(descript, 80, fp);
>     P(sprintf("hellfr_miss_char(%3d) is%11.3f %s", i,
>         hellfr_miss_char[i], descript));
>     ++i;
> }
>
> fclose(fp);
> /* END DEFAULT CHARACTERISTIC DATA FOR miss_hellfr.c READ FROM FILE */
>
> /* DEFAULT TIME-OF-FLIGHT DATA FOR miss_hellfr.c READ FROM FILE */
> fp = fopen("/simnet/data/ms_hf_tf.d","r");
> if(fp==NULL){
>     fprintf(stderr, "Cannot open /simnet/data/ms_hf_tf.d\n");
>     exit();
> }
>
> rewind(fp);
>
> /* Read degree of polynomial */
>
> fscanf(fp,"%d", &data_tmp_int);
> hellfr_miss_poly_deg[0] = data_tmp_int;
> fgets(descript, 80, fp);
> P(sprintf("hellfr_miss_poly_deg(0) is%3d %s",
>     hellfr_miss_poly_deg[0], descript));
>
> /* Read array data */
>
> i=0;
>
> while(fscanf(fp,"%f", &data_tmp) != EOF)
> {
>     hellfire_tof_coeff[i] = data_tmp;
>     fgets(descript, 80, fp);
>     P(sprintf("hellfire_tof_coeff(%3d) is%11.3f %s", i,
>         hellfire_tof_coeff[i], descript));
>     ++i;
> }
>
> fclose(fp);
> /* END DEFAULT TIME-OF-FLIGHT DATA FOR miss_hellfr.c READ FROM FILE */
>
> /* DEFAULT BURN SPEED DATA FOR miss_hellfr.c READ FROM FILE */
> fp = fopen("/simnet/data/ms_hf_bs.d","r");
> if(fp==NULL){
>     fprintf(stderr, "Cannot open /simnet/data/ms_hf_bs.d\n");
>     exit();
> }
>
> rewind(fp);

```

```

> / * Read degree of polynomial * /
>
> fscanf(fp,"%d", &data_tmp_int);
> hellfr_miss_poly_deg[1] = data_tmp_int;
> fgets(descript, 80, fp);
> P(printf("hellfr_miss_poly_deg(1) is%3d %s",
>         hellfr_miss_poly_deg[1], descript));
>
> / * Read array data * /
>
> i=0;
>
> while(fscanf(fp,"%f", &data_tmp) != EOF)
> {
>     hellfire_burn_speed_coeff[i] = data_tmp;
>     fgets(descript, 80, fp);
>     P(printf("hellfire_burn_speed_coeff(%3d) is%11.3f %s", i,
>             hellfire_burn_speed_coeff[i], descript));
>     ++i;
> }
>> fclose(fp);
> /* END DEFAULT BURN SPEED DATA FOR miss_hellfr.c READ FROM FILE * /
> /* DEFAULT COAST SPEED DATA FOR miss_hellfr.c READ FROM FILE */
> fp = fopen("/simnet/data/ms_hf_cs.d","r");
> if(fp==NULL){
>     fprintf(stderr, "Cannot open /simnet/data/ms_hf_cs.d\n");
>     exit();
> }
>> rewind(fp);
>
> / * Read degree of polynomial * /
>
> fscanf(fp,"%d", &data_tmp_int);
> hellfr_miss_poly_deg[2] = data_tmp_int;
> fgets(descript, 80, fp);
> P(printf("hellfr_miss_poly_deg(2) is%3d %s",
>         hellfr_miss_poly_deg[2], descript));
>
> / * Read array data * /
>
> i=0;
>
> while(fscanf(fp,"%f", &data_tmp) != EOF)
> {
>     hellfire_coast_speed_coeff[i] = data_tmp;
>     fgets(descript, 80, fp);
>     P(printf("hellfire_coast_speed_coeff(%3d) is%11.3f %s", i,
>             hellfire_coast_speed_coeff[i], descript));
>     ++i;
> }
>> fclose(fp);
> /* END DEFAULT COAST SPEED DATA FOR miss_hellfr.c READ FROM FILE * /
>

```

Difference File for miss_stinger.c

```

1c1
< /* $Header: /a3/adst-cm/RWA/ATACII/libsrc/libmissile/RCS/miss_stinger.c,v 1.1
1993/02/15 22:17:50 cm-adst Exp $ */
- - -
> /* $Header: /a3/adst-cm/RWA/ATACII/libsrc/libmissile/RCS/miss_stinger.c,v 1.2
1993/04/06 19:12:50 cm-adst Exp $ */
3a4,6
> * Revision 1.2 1993/04/06 19:12:50 cm-adst
> * A. Au-Yeung's changes for socr 124
> *
8c11
< static char RCS_ID[] = "$Header: /a3/adst-
cm/RWA/ATACII/libsrc/libmissile/RCS/miss_stinger.c,v 1.1 1993/02/15 22:17:50 cm-adst
Exp $";
- - -
> static char RCS_ID[] = "$Header: /a3/adst-
cm/RWA/ATACII/libsrc/libmissile/RCS/miss_stinger.c,v 1.2 1993/04/06 19:12:50 cm-adst
Exp $";
11c14
< static char rcsid [] = "$RCSfile: miss_stinger.c,v $ $Revision: 1.1 $ $State: Exp $";
- - -
> static char rcsid [] = "$RCSfile: miss_stinger.c,v $ $Revision: 1.2 $ $State: Exp $";
13,29d15
< /.....
< *
< * FILE:      miss_stinger.c
< * AUTHOR:   Bryant Collard
< * MAINTAINER: Bryant Collard
< * PURPOSE:   This file contains routines which fly out a
< *           missile with the characteristics of a STINGER
< *           missile.
< * HISTORY:  12/08/88 bryant: Creation
< *           04/24/89 bryant: Added static memory allocation
< *           08/07/90 bryant: NIU librva modifications.
< *
< * Copyright (c) 1988 BBN Systems and Technologies, Inc.
< * All rights reserved.
< *
< ...../
30a17,65
>
/.....
.....

```

```

> * FILE:      miss_stinger.c
> * AUTHOR:    Bryant Collard
> * MAINTAINER: Bryant Collard
> * PURPOSE:    This file contains routines which fly out a
> *             missile with the characteristics of a STINGER
> *             missile.
> * HISTORY:   12/08/88 bryant: Creation
> *             04/24/89 bryant: Added static memory allocation
> *             08/07/90 bryant: NIU librva modifications.
>
> * Copyright (c) 1988 BBN Systems and Technologies, Inc.
> * All rights reserved.

```

> * Revisions:

Version	Date	Author	Description	SP/CR Number
1.2	03/25/93	A. Au-Yeung	ported in all Airmet upgrades rev1.4 of AIRNET miss_stinger.c	124,31

SP/CR No.	Description of Modification
124	Airmet upgrades Data File Initialization. Added pathname to data directory. Changed %i to %d Hard coded defines changed to array elements. Characteristics/parameter data array added. Degree of polynomial data array added. Added file reads for stinger characteristics/ parameters, burn speed coefficients, and coast speed coefficients. Added "/simnet/data/" to each data file pathname.
31	Increased the size of fgets to make sure the whole line is read in.

```

>
> .....
> ...../
>
50a86,94
> /*
> * Debug macro
> */
> #ifdef FILEDBG
> #define P(a)      a
> #else
> #define P(a)
> #endif
>
55,62c99,106
< #define STINGER_BURNOUT_TIME      19.125      /* ticks (1.275 sec) */
< #define STINGER_MAX_FLIGHT_TIME  400.000      /* ticks (26.667 sec) */
< #define STINGER_TYPICAL_FLIGHT_TIME 75.0      /* ticks (5.0 sec) */
< #define STINGER_LOCK_THRESHOLD    0.953153895 /* cos (12.5 deg) ** 2 */
< #define SPEED_0                    53.33333333 /* m/tick (800 m/sec) */
< #define THETA_0                     0.0174     /* rad/tick (15.0 deg/sec) */
< #define INVEST_DIST_SQ              90000.0    /* (300 m) ** 2 */
< #define FUZE_DIST_SQ                 400.0     /* (20 m) ** 2 */
...
> #define STINGER_BURNOUT_TIME      stinger_miss_char[ 0]
> #define STINGER_MAX_FLIGHT_TIME   stinger_miss_char[ 1]
> #define STINGER_LOCK_THRESHOLD    stinger_miss_char[ 2]
> #define SPEED_0                    stinger_miss_char[ 3]
> #define THETA_0                     stinger_miss_char[ 4]
> #define INVEST_DIST_SQ              stinger_miss_char[ 5]
> #define FUZE_DIST_SQ                 stinger_miss_char[ 6]
> #define STINGER_TYPICAL_FLIGHT_TIME stinger_miss_char[7]
63a108,110
> #define STINGER_BURN_SPEED_DEG    stinger_miss_poly_deg[0]
> #define STINGER_COAST_SPEED_DEG   stinger_miss_poly_deg[1]
>
73c120,121
< * Coefficients for the speed polynomial before motor burnout.
...
> * The following terms set the order of the polynomials used to determine
> * the speed of the missile at any point in time.
74a123,127
> static int stinger_miss_poly_deg[2] =
> {
>     1, /* burn speed poly degree - speed before motor burnout */
>     3 /* coast speed poly degree - speed after motor burnout */
> };
76c129,132
< static REAL stinger_burn_speed_coeff[STINGER_BURN_SPEED_DEG + 1] =
...

```

```

> /*
> * Stinger missile characteristic parameters initialized to default values.
> /*
> static REAL stinger_miss_char[15] =
77a134,157
> 19.125,      /* ticks (1.275 sec) */
> 400.000,     /* ticks (26.667 sec) */
> 0.953153895, /* cos (12.5 deg) ** 2 */
> 53.33333333, /* m/tick (800 m/sec) */
> 0.0174,     /* rad/tick (15.0 deg/sec) */
> 90000.0,    /* (300 m) ** 2 */
> 400.0,      /* (20 m) ** 2 */
> 75.0,       /* ticks 5.0 */
> 0.0,
> 0.0,
> 0.0,
> 0.0,
> 0.0,
> 0.0
> };
>
> /*
> * Coefficients for the speed polynomial before motor burnout initialized to
> * default values.
> /*
>
> static REAL stinger_burn_speed_coeff[STINGER_BURN_SPEED_DEG_MAX + 1] =
> {
79c159,168
< 2.689324619      /* a_1 - m/tick**2 */
...
> 2.689324619,     /* a_1 - m/tick**2 */
> 0.0,
> 0.0,
> 0.0,
> 0.0,
> 0.0,
> 0.0,
> 0.0,
> 0.0
83c172,173
< * Coefficients for the speed polynomial after motor burnout.
...
> * Coefficients for the speed polynomial after motor burnout initialized to
> * default values.
86c176
< static REAL stinger_coast_speed_coeff[STINGER_COAST_SPEED_DEG + 1] =
...
> static REAL stinger_coast_speed_coeff[STINGER_COAST_SPEED_DEG_MAX + 1] =
91c181,188
< -1.0176282e-7    /* a_3 - m/tick**4 */
...

```

```

> -1.0176282e-7,      /* a_3 - m/tick**4 */
> 0.0,
> 0.0,
> 0.0,
> 0.0,
> 0.0,
> 0.0,
> 0.0
136a234,329
> int j;
> int data_tmp_int;
> float data_tmp;
> char descript(80);
> FILE *fp;
>
> P(printf("$$$$$ STINGER missile file data $$$$\n"));
>
> /* DEFAULT CHARACTERISTIC DATA FOR miss_stinger.c READ FROM FILE */
> fp = fopen("/simnet/data/ms_st_ch.d","r");
> if(fp==NULL){
>     fprintf(stderr, "Cannot open /simnet/data/ms_st_ch.d\n");
>     exit();
> }
>
> rewind(fp);
>
> /* Read array data */
> j=0;
>
> while(fscanf(fp,"%f", &data_tmp) != EOF){
>     stinger_miss_char[j] = data_tmp;
>     fgets(descript, 80, fp);
>     P(printf("stinger_miss_char(%3d) is%11.3f %s", j,
>         stinger_miss_char[j],
>         descript));
>     ++j;
> }
>
> fclose(fp);
> /* END DEFAULT CHARACTERISTIC DATA FOR miss_stinger.c READ FROM FILE */
>
> /* DEFAULT BURN SPEED DATA FOR miss_stinger.c READ FROM FILE */
> fp = fopen("/simnet/data/ms_st_bs.d","r");
> if(fp==NULL){
>     fprintf(stderr, "Cannot open /simnet/data/ms_st_bs.d\n");
>     exit();
> }
>
> rewind(fp);
>

```

```

> / * Read degree of polynomial * /
>
> fscanf(fp,"%d", &data_tmp_int);
> stinger_miss_poly_deg[0] = data_tmp_int;
> fgets(descript, 80, fp);
> P(printf("stinger_miss_poly_deg(0) is%3d %s",
> stinger_miss_poly_deg[0], descript));
>
> / * Read array data * /
> j=0;
>
> while(fscanf(fp,"%f", &data_tmp) != EOF){
>     stinger_burn_speed_coeff[j] = data_tmp;
>     fgets(descript, 80, fp);
>     P(printf("stinger_burn_speed_coeff(%3d) is%11.3f %s", j,
> stinger_burn_speed_coeff[j],
> descript));
>     ++j;
> }
>> fclose(fp);
> / END DEFAULT BURN SPEED DATA FOR miss_stinger.c READ FROM FILE * /
> / DEFAULT COAST SPEED DATA FOR miss_stinger.c READ FROM FILE * /
> fp = fopen("/simnet/data/ms_st_cs.d","r");
> if(fp==NULL){
>     fprintf(stderr, "Cannot open /simnet/data/ms_st_cs.d\n");
>     exit();
> }
>> rewind(fp);
>
> / * Read degree of polynomial * /
>
> fscanf(fp,"%d", &data_tmp_int);
> stinger_miss_poly_deg[1] = data_tmp_int;
> fgets(descript, 80, fp);
> P(printf("stinger_miss_poly_deg(1) is%3d %s",
> stinger_miss_poly_deg[1], descript));
>
> / * Read array data * /
> j=0;
>
> while(fscanf(fp,"%f", &data_tmp) != EOF){
>     stinger_coast_speed_coeff[j] = data_tmp;
>     fgets(descript, 80, fp);
>     P(printf("stinger_coast_speed_coeff(%3d) is%11.3f %s", j,
> stinger_coast_speed_coeff[j],
> descript));
>     ++j;
> }
>> fclose(fp);
> / END DEFAULT COAST SPEED DATA FOR miss_stinger.c READ FROM FILE * /
>
322a516
>

```

Difference File for miss_tow.c

```

1c1
< /* $Header: /a3/adst-cm/RWA/ATACII/libsrc/libmissile/RCS/miss_tow.c,v 1.1 1993/02/15
22:17:50 cm-adst Exp $ */
...
> /* $Header: /a3/adst-cm/RWA/ATACII/libsrc/libmissile/RCS/miss_tow.c,v 1.3 1993/04/09
00:11:22 cm-adst Exp $ */
3a4,9
> * Revision 1.3 1993/04/09 00:11:22 cm-adst
> * P. Desmeules's change for socr 124
> *
> * Revision 1.2 1993/04/06 19:12:50 cm-adst
> * A. Au-Yeung's changes for socr 124
> *
8c14
< static char RCS_ID[] = "$Header: /a3/adst-
cm/RWA/ATACII/libsrc/libmissile/RCS/miss_tow.c,v 1.1 1993/02/15 22:17:50 cm-adst Exp
$";
...
> static char RCS_ID[] = "$Header: /a3/adst-
cm/RWA/ATACII/libsrc/libmissile/RCS/miss_tow.c,v 1.3 1993/04/09 00:11:22 cm-adst Exp
$";
11c17
< static char rcsid [] = "$RCSfile: miss_tow.c,v $ $Revision: 1.1 $ $State: Exp $";
...
> static char rcsid [] = "$RCSfile: miss_tow.c,v $ $Revision: 1.3 $ $State: Exp $";
13,28d18
< /.....
< *
< * FILE:      miss_tow.c
< * AUTHOR:   Bryant Collard
< * MAINTAINER: Bryant Collard
< * PURPOSE:  This file contains routines which fly out a
< *           missile with the characteristics of a TOW
< *           missile.
< * HISTORY:  10/31/88 bryant: Creation
< *           4/26/89 bryant: Added statically allocated mem
< *
< * Copyright (c) 1988 BBN Systems and Technologies, Inc.
< * All rights reserved.
< *
< ...../
29a20,68
>
/.....
.....

```

```

> *
> * FILE:      miss_tow.c
> * AUTHOR:   Bryant Collard
> * MAINTAINER: Bryant Collard
> * PURPOSE:   This file contains routines which fly out a
> *           missile with the characteristics of a TOW
> *           missile.
> * HISTORY:  10/31/88 bryant: Creation
> *           4/26/89 bryant: Added statically allocated mem
> *
> * Copyright (c) 1988 BBN Systems and Technologies, Inc.
> * All rights reserved.

```

.....
/

/.....

> * Revisions:

```

> * Version  Date      Author      Description      SP/CR Number
> * -----  -

```

```

> * 1.2      03/25/93  A. Au-Yeung  ported in all Airmet upgrades  124,31
> *                               rev1.4 of AIRNET miss_tow.c

```

.....
/

/.....

```

> * SP/CR No.  Description of Modification
> * -----

```

```

> * 124      Airmet upgrades
> *          Data File Initialization.
> *          Added pathname to data directory.
> *          Changed %i to %d
> *          Hard coded defines changed to array elements.
> *          Characteristics/parameter data array added.
> *          Degree of polynomial data array added.
> *          Added file reads for TOW characteristics/parameters,
> *          burn speed coefficients, coast speed coefficients,
> *          burn turn coefficients, and coast turn coefficients.
> *
> *          Added "/simnet/data/" to each data file pathname.
> * 31      Increased the size of fgets to make sure the whole line is
> *          read in.

```

```

> .....
> ...../
>
47a87,96
> /*
> * Debug macro
> */
>
> #ifdef FILEDBG
> #define P(a)      a
> #else
> #define P(a)
> #endif
>
52,55c101,103
< #define TOW_BURNOUT_TIME      24.0 /* ticks (1.6 sec) */
< #define TOW_RANGE_LIMIT_TIME 268.35 /* ticks (17.89 sec) */
< #define TOW_MAX_FLIGHT_TIME  300.00 /* ticks - cos of max turn > 1.0 beyond
<                               this point */
- - -
> #define TOW_BURNOUT_TIME      tow_miss_char[0]
> #define TOW_RANGE_LIMIT_TIME tow_miss_char[1]
> #define TOW_MAX_FLIGHT_TIME  tow_miss_char[2]
63,66c111,114
< #define TOW_BURN_SPEED_DEG  2      /* Speed before motor burnout. */
< #define TOW_COAST_SPEED_DEG 3      /* Speed after motor burnout. */
< #define TOW_BURN_TURN_DEG   1      /* Cosine of max turn before burnout. */
< #define TOW_COAST_TURN_DEG  3      /* Cosine of max turn after burnout. */
- - -
> #define TOW_BURN_SPEED_DEG tow_miss_poly_deg[0]
> #define TOW_COAST_SPEED_DEG tow_miss_poly_deg[1]
> #define TOW_BURN_TURN_DEG  tow_miss_poly_deg[2]
> #define TOW_COAST_TURN_DEG tow_miss_poly_deg[3]
69c117
< * Coefficients for the speed polynomial before motor burnout.
- - -
> * Tow missile characteristic parameters initialized to default values.
70a119,126
> static REAL tow_miss_char[5] =
> {
>   24.0, /* t      .6 sec) */
>   268.35, /* u .s (17.89 sec) */
>   300.00, /* ticks - cos of max turn > 1.0 beyond this point */
>   0.0,
>   0.0
> };
72c128,132
< static REAL tow_burn_speed_coeff[TOW_BURN_SPEED_DEG + 1] =
- - -
> /*
> * The following terms set the order of the polynomials used to determine
> * the speed and turn of the missile at any point in time.
> /*
> static int tow_miss_poly_deg[5] =

```

```

73a134,147
> 2, /* Speed before motor burnout. */
> 3, /* Speed after motor burnout. */
> 1, /* Cosine of max turn before burnout. */
> 3, /* Cosine of max turn after burnout. */
> 0 /* not used. */
> );
>
> /*
> * Coefficients for the speed polynomial before motor burnout initialized
> * to default values.
> */
>
> static REAL tow_burn_speed_coeff[5] =
> {
76c150,152
< -0.024532086 /* a_2 - m/tick**3 (-82.7057910 m/sec**3) */
...
> -0.024532086, /* a_2 - m/tick**3 (-82.7057910 m/sec**3) */
> 0.0,
> 0.0
83c159
< static REAL tow_coast_speed_coeff[TOW_COAST_SPEED_DEG + 1] =
...
> static REAL tow_coast_speed_coeff[5] =
87,88c163,165
< 2.4378222e-4, /* a_2 - m/tick**3 (0.8227650 m/sec**3) */
< -2.6311111e-7 /* a_3 - m/tick**4 (-0.0133200 m/sec**4) */
...
> 2.4378222e-4, /* a_2 - m/tick**3 (0.8227650 m/sec**3) */
> -2.6311111e-7, /* a_3 - m/tick**4 (-0.0133200 m/sec**4) */
> 0.0
99c176
< TOW_BURN_TURN_DEG, /* Order of the polynomials. */
...
> 1, /* Order of the polynomials. */
101c178
< /* Sideways turn. */
...
> /* Sideways turn. */
103c180
< -3.5933955e-7 /* a_1 - cos(rad)/tick**2 */
...
> -3.5933955e-7 /* a_1 - cos(rad)/tick**2 */
106c183
< /* Upwards turn. */
...
> /* Upwards turn. */
108c185
< -3.1492328e-6 /* a_1 - cos(rad)/tick**2 */
...
> -3.1492328e-6 /* a_1 - cos(rad)/tick**2 */
111c188
< /* Downwards turn. */

```



```

...
> /* Downwards turn. */
113c190
< -7.8194991e-9 /* a_1 - cos(rad)/tick**2 */
...
> -7.8194991e-9 /* a_1 - cos(rad)/tick**2 */
123c200
< TOW_COAST_TURN_DEG, /* Order of the polynomials. */
...
> 3, /* Order of the polynomials. */
125c202
< /* Sideways turn. */
...
> /* Sideways turn. */
128c205
< -5.995375e-9, /* a_2 - cos(rad)/tick**3 */
...
> -5.995375e-9, /* a_2 - cos(rad)/tick**3 */
132c209
< /* Upwards turn. */
...
> /* Upwards turn. */
135c212
< -8.231861e-9, /* a_2 - cos(rad)/tick**3 */
...
> -8.231861e-9, /* a_2 - cos(rad)/tick**3 */
139c216
< /* Downwards turn. */
...
> /* Downwards turn. */
142c219
< -1.601259e-9, /* a_2 - cos(rad)/tick**3 */
...
> -1.601259e-9, /* a_2 - cos(rad)/tick**3 */
173a251,437
> int i;
> int data_tmp_int;
> float data_tmp;
> char descrpt[80];
> FILE *fp;
>
> P(printf("$$$$ TOW missile file data $$$$\\n"));
>
> /* DEFAULT CHARACTERISTICS DATA FOR miss_tow.c READ FROM FILE */
> fp = fopen("/simnet/data/ms_tw_ch.d","r");
> if(fp==NULL){
>     fprintf(stderr, "Cannot open /simnet/data/ms_tw_ch.d\\n");
>     exit();
> }
>
> rewind(fp);
>
> /* Read array data */
> i=0;

```

```

>
> while(fscanf(fp,"%f", &data_tmp) != ECF){
>     tow_miss_char[i] = data_tmp;
>     fgets(descript, 80, fp);
>     P(sprintf("tow_miss_char(%3d) is%11.3f %s", i, tow_miss_char[i],
>         descript));
>     ++i;
> }
>
> fclose(fp);
> /* END DEFAULT CHARACTERISTICS DATA FOR miss_tow.c READ FROM FILE */
>
> /* DEFAULT BURN SPEED DATA FOR miss_tow.c READ FROM FILE */
> fp = fopen("/simnet/data/ms_tw_bs.d","r");
> if(fp==NULL){
>     fprintf(stderr, "Cannot open /simnet/data/ms_tw_bs.d\n");
>     exit();
> }
>
> rewind(fp);
>
> /* Read degree of polynomial */
>
> fscanf(fp,"%d", &data_tmp_int);
> TOW_BURN_SPEED_DEG = data_tmp_int;
> fgets(descript, 80, fp);
> P(sprintf("tow_miss_poly_deg(0) is%3d %s", TOW_BURN_SPEED_DEG,
>     descript));
>
> /* Read array data */
> i=0;
>
> while(fscanf(fp,"%f", &data_tmp) != EOF){
>     tow_burn_speed_coeff[i] = data_tmp;
>     fgets(descript, 80, fp);
>     P(sprintf("tow_burn_speed_coeff(%3d) is%11.3f %s", i,
>         tow_burn_speed_coeff[i], descript));
>     ++i;
> }
>
> fclose(fp);
> /* END DEFAULT BURN SPEED DATA FOR miss_tow.c READ FROM FILE */
>
> /* DEFAULT COAST SPEED DATA FOR miss_tow.c READ FROM FILE */
> fp = fopen("/simnet/data/ms_tw_cs.d","r");
> if(fp==NULL){
>     fprintf(stderr, "Cannot open /simnet/data/ms_tw_cs.d\n");
>     exit();
> }
>
> rewind(fp);

```

```

> / * Read degree of polynomial */
>
> fscanf(fp,"%d", &data_tmp_int);
> TOW_COAST_SPEED_DEG = data_tmp_int;
> fgets(descript, 80, fp);
> P(printf("tow_miss_poly_deg(1) is%3d %s", TOW_COAST_SPEED_DEG,
> descript));
>
> / * Read array data * /
> i=0;
>
> while(fscanf(fp,"%f", &data_tmp) != EOF){
> tow_coast_speed_coeff[i] = data_tmp;
> fgets(descript, 80, fp);
> P(printf("tow_coast_speed_coeff(%3d) is%11.3f %s", i,
> tow_coast_speed_coeff[i], descript));
> ++i;
> }
>
> fclose(fp);
> /* END DEFAULT COAST SPEED DATA FOR miss_tow.c READ FROM FILE * /
>
> /* DEFAULT BURN TURN DATA FOR miss_tow.c READ FROM FILE * /
> fp = fopen("/simnet/data/ms_tw_bt.d","r");
> if(fp==NULL){
> fprintf(stderr, "Cannot open /simnet/data/ms_tw_bt.d\n");
> exit();
> }
>
> rewind(fp);
>
> / * Read degree of polynomial */
>
> fscanf(fp,"%d", &data_tmp_int);
> TOW_BURN_TURN_DEG = data_tmp_int;
> tow_burn_turn_coeff.deg = data_tmp_int;
> fgets(descript, 80, fp);
> P(printf("tow_miss_poly_deg(2) is%3d %s", TOW_BURN_TURN_DEG,
> descript));
>
> / * Read array data * /
>
> for (i=0; i <= data_tmp_int; i++) {
> fscanf(fp,"%f", &data_tmp);
> tow_burn_turn_coeff.side_coeff[i] = data_tmp;
> fgets(descript, 80, fp);
> P(printf("tow_burn_turn_coeff.side_coeff(%3d) is%11.3f %s", i,
> tow_burn_turn_coeff.side_coeff[i], descript));
> }
>

```

```

> for (i=0; i <= data_tmp_int; i++) {
>     fscanf(fp,"%f", &data_tmp);
>     tow_burn_turn_coef.up_coef[i] = data_tmp;
>     fgets(descript, 80, fp);
>     P(sprintf("tow_burn_turn_coef.up_coef(%3d) is%11.3f %s", i,
>         tow_burn_turn_coef.up_coef[i], descript));
> }
>
> for (i=0; i <= data_tmp_int; i++) {
>     fscanf(fp,"%f", &data_tmp);
>     tow_burn_turn_coef.down_coef[i] = data_tmp;
>     fgets(descript, 80, fp);
>     P(sprintf("tow_burn_turn_coef.down_coef(%3d) is%11.3f %s", i,
>         tow_burn_turn_coef.down_coef[i], descript));
> }
>
> fclose(fp);
> /* END DEFAULT BURN TURN DATA FOR miss_tow.c READ FROM FILE */
>
> /* DEFAULT COAST TURN DATA FOR miss_tow.c READ FROM FILE */
> fp = fopen("/simnet/datz/ms_tw_ct.d","r");
> if(fp==NULL){
>     fprintf(stderr, "Cannot open /simnet/datz/ms_tw_ct.d\n");
>     exit();
> }
>
> rewind(fp);
>
> /* Read degree of polynomial */
>
> fscanf(fp,"%d", &data_tmp_int);
> TOW_COAST_TURN_DEG = data_tmp_int;
> tow_coast_turn_coef.deg = data_tmp_int;
> fgets(descript, 80, fp);
> P(sprintf("tow_miss_poly_deg(3) is%3d %s", TOW_COAST_TURN_DEG,
>     descript));
>
> /* Read array data */
>
> for (i=0; i <= data_tmp_int; i++) {
>     fscanf(fp,"%f", &data_tmp);
>     tow_coast_turn_coef.side_coef[i] = data_tmp;
>     fgets(descript, 80, fp);
>     P(sprintf("tow_coast_turn_coef.side_coef(%3d) is%11.3f %s", i,
>         tow_coast_turn_coef.side_coef[i], descript));
> }
>
> for (i=0; i <= data_tmp_int; i++) {
>     fscanf(fp,"%f", &data_tmp);
>     tow_coast_turn_coef.up_coef[i] = data_tmp;
>     fgets(descript, 80, fp);
>     P(sprintf("tow_coast_turn_coef.up_coef(%3d) is%11.3f %s", i,
>         tow_coast_turn_coef.up_coef[i], descript));
> }

```

```
>
>   for (i=0; i <= data_tmp_int; i++) {
>       fscanf(fp,"%f", &data_tmp);
>       tow_coast_turn_coeff.down_coeff[i] = data_tmp;
>       fgets(descript, 80, fp);
>       P(printf("tow_coast_turn_coeff.down_coeff(%3d) is%11.3f %s", i,
>               tow_coast_turn_coeff.down_coeff[i], descript));
>   }
>
>   fclose(fp);
> /* END DEFAULT COAST TURN DATA FOR miss_tow.c READ FROM FILE * /
>
```

Difference file for rwa_hydra.c

```

1c1
< /* $Header: /a3/adst-cm/RWA/ATACII/src/rwa/src/RCS/rwa_hydra.c,v 1.1 1993/02/15
22:40:52 cm-adst Exp $ */
...
> /* $Header: /a3/adst-cm/RWA/ATACII/src/rwa/src/RCS/rwa_hydra.c,v 1.2 1993/04/06
19:03:08 cm-adst Exp $ */
3a4,6
> * Revision 1.2 1993/04/06 19:03:08 cm-adst
> * A. Au-Yeung's changes for socr 124
> *
8c11
< static char RCS_ID[] = "$Header: /a3/adst-cm/RWA/ATACII/src/rwa/src/RCS/rwa_hydra.c,v
1.1 1993/02/15 22:40:52 cm-adst Exp $";
...
> static char RCS_ID[] = "$Header: /a3/adst-cm/RWA/ATACII/src/rwa/src/RCS/rwa_hydra.c,v
1.2 1993/04/06 19:03:08 cm-adst Exp $";
11c14
< static char rcsid [] = "$RCSfile: rwa_hydra.c,v $ $Revision: 1.1 $ $State: Exp $";
...
> static char rcsid [] = "$RCSfile: rwa_hydra.c,v $ $Revision: 1.2 $ $State: Exp $";
13,23c16,54
<
/.....
< * SYSTEM NAME: rwa
< * FILE: rwa_hydra.c
< * AUTHOR: Kris Bartol
< *
< * SIMNET simulation of Hydra70 Rocket
< *
< * Copyright (c) 1990 BBN Advanced Simulation Division.
< * All rights reserved.
< *
< ...../
...
>
>
/.....
.....
> * SYSTEM NAME: rwa
> * FILE: rwa_hydra.c
> * AUTHOR: Kris Bartol
> *
> * SIMNET simulation of Hydra70 Rocket
> *
> * Copyright (c) 1990 BBN Advanced Simulation Division.
> * All rights reserved.
> *
> ...../
...
>
/.....
.....
> *

```

> * Revisions:

```

> *
> * Version  Date      Author      Description      SP/CR Number
> * -----  -
> * 1.2      03/23/93  A. Au-Yeung  ported in all  Airnet upgrades  124,31
> *                                     rev1.4 of AIRNET rwa_aerodyn.c
> *
> *
> *

```

> * SP/CR No. Description of Modification

```

> *
> * 124      Airnet upgrades
> *          Data File Initialization.
> *          Added pathname to data directory.
> *          Hard coded defines changed to array elements.
> *          Characteristics/parameter data array added.
> *          Added file reads for hydra rocket characteristics/parameters.
> *          Added "/simnet/data/" to each data file pathname.
> *
> * 31      Increased the size of fgets to make sure the whole line is
> *          read in.
> *
> *

```

```

>
49a81,89
> /*

```

```

> * Debug macro
> */

```

```

> #ifdef FILEDBG

```

```

> #define P(a)      a

```

```

> #else

```

```

> #define P(a)

```

```

> #endif
>

```

```

57,59c97,99

```

```

< #define HYDRA_LAUNCHER_POS_X      4.5
< #define HYDRA_LAUNCHER_POS_Y      0.5
< #define HYDRA_LAUNCHER_POS_Z      -2.0

```

```

> /*

```

```

> * Define rocket characteristics.

```

```

> /*

```

```

60a101,104
> #define HYDRA_LAUNCHER_POS_X      hydra_rkt_char[0]
> #define HYDRA_LAUNCHER_POS_Y      hydra_rkt_char[1]
> #define HYDRA_LAUNCHER_POS_Z      hydra_rkt_char[2]
>
65,68c109,112
< #define SOVIET_ARTICULATION      ( mil_to_rad( 104.0 ))
< #define HULL_NEG_5_PITCH          ( deg_to_rad( -5.0 ))
< #define ARTICULATION_MAX         ( deg_to_rad( 19.0 ))
< #define ARTICULATION_MIN         ( deg_to_rad( -15.0 ))
...
> #define SOVIET_ARTICULATION      ( mil_to_rad(hydra_rkt_char[3]))
> #define HULL_NEG_5_PITCH          ( deg_to_rad(hydra_rkt_char[4]))
> #define ARTICULATION_MAX         ( deg_to_rad(hydra_rkt_char[5]))
> #define ARTICULATION_MIN         ( deg_to_rad(hydra_rkt_char[6]))
69a114,127
> /*
> * Hydra rocket characteristic parameters initialized to default values.
> */
> static REAL hydra_rkt_char[7] =
> {
>     4.5, /* hydra launcher position X */
>     0.5, /* hydra launcher position Y */
>     -2.0, /* hydra launcher position Z */
>     104.0, /* mils of Soviet articulation */
>     -5.0, /* degrees of hull negative pitch */
>     19.0, /* degrees of maximum articulation */
>     -15.0 /* degrees of minimum articulation */
> };
>
89,92c147,149
< static VECTOR left_launcher_pos = { HYDRA_LAUNCHER_POS_X, 0.0, 0.0 };
< static VECTOR right_launcher_pos = { HYDRA_LAUNCHER_POS_X, 0.0, 0.0 };
< static VECTOR articulation_pos =
< { 0.0, HYDRA_LAUNCHER_POS_Y, HYDRA_LAUNCHER_POS_Z };
...
> static VECTOR left_launcher_pos = { 4.5, 0.0, 0.0 };
> static VECTOR right_launcher_pos = { 4.5, 0.0, 0.0 };
> static VECTOR articulation_pos = { 0.0, 0.5, -2.0 };
250a308,343
>     int     i;
>     int     data_tmp_int;
>     float   data_tmp;
>     char    descript[80];
>     FILE    *fp;
>
>     P(sprintf("$$$$ HYDRA file data $$$$\n"));
>
> /* DEFAULT CHARACTERISTICS DATA FOR rwa_hydra.c READ FROM FILE      * /
>     fp = fopen("/simnet/data/rwa_hydr.d","r");
>     if(fp==NULL){
>         fprintf(stderr, "Cannot open /simnet/data/rwa_hydr.d\n");
>         exit();
>     }

```



```

>
> rewind(fp);
>
> / * Read array data * /
> i=0;
>
> while(fscanf(fp,"%f", &data_tmp) != EOF){
>     hydra_rkt_char[i] = data_tmp;
>     fgets(descript, 80, fp);
>     P(sprintf("hydra_rkt_char(%3d) is%11.3f %s", i,
>             hydra_rkt_char[i], descript));
>     ++i;
> }
>
> fclose(fp);
> /* END DEFAULT CHARACTERISTICS DATA FOR rwa_hydra.c READ FROM FILE * /
>
> left_launcher_pos[0] = HYDRA_LAUNCHER_POS_X;
> right_launcher_pos[0] = HYDRA_LAUNCHER_POS_X;
> articulation_pos[1] = HYDRA_LAUNCHER_POS_Y;
> articulation_pos[2] = HYDRA_LAUNCHER_POS_Z;
>
267,268c360,361
<
< HYDRA_LAUNCHER_POS_Y,
< HYDRA_LAUNCHER_POS_Z);
<
<
<
< HYDRA_LAUNCHER_POS_Y,
< HYDRA_LAUNCHER_POS_Z);

```

AIRNET INSPECTION/ANALYSIS REPORT 6

Req. No.: 3.9.3	Spec. Para.: 3.9.3
3.9.3.a	3.9.3
3.9.3.b	3.9.3
3.9.3.c	3.9.3
3.9.5	3.9.5
3.9.5.a	3.9.5
3.9.5.b	3.9.5
3.9.5.c	3.9.5

Requirement Descriptions:

Req. No.: 3.9.3 RWA Flight Model Upgrade Segment Qualification
The RWA Flight Model Upgrade Segment shall be qualification tested at Ft. Rucker.

Req. No.: 3.9.3.a RWA Flight Model Upgrade Segment Qualification
The RWA Flight Model Upgrade Segment test shall take place during the program integration and test phase (I&T).

Req. No.: 3.9.3.b RWA Flight Model Upgrade Segment Qualification
The RWA Flight Model Upgrade Segment test shall not exceed 2 working days.

Req. No.: 3.9.3.c RWA Flight Model Upgrade Segment Qualification
The testing shall demonstrate the RWA Flight Model Segment Upgrade provides the functionality described previously in this document.

Req. No.: 3.9.5 RWA Weapons Model Segment Qualification
The RWA Weapons Model Upgrade Segment shall be qualification tested at Ft. Rucker.

Req. No.: 3.9.5.a RWA Weapons Model Segment Qualification
The RWA Weapons Model Upgrade Segment test shall take place during the program integration and test phase (I&T).

Req. No.: 3.9.5.b RWA Weapons Model Segment Qualification
The RWA Weapons Model Upgrade Segment test shall not exceed 2 working days.

Req. No.: 3.9.5.c RWA Weapons Model Segment Qualification
The testing shall demonstrate the RWA Weapons Model Upgrade Segment provides the functionality described previously in this document.

Inspection Method: The test procedures for Scenario B can be inspected to verify compliance with the requirements listed above.

VERIFIED: _____

TITLE: _____

CONCURRENCE: _____

AIRNET INSPECTION/ANALYSIS REPORT 7

Action Item No.: 9

Ref.: AIRNET Conversion PMR Minutes, 10/6/92

Action Item Description: Add "spare time test" to the test plan.

From the meeting minutes: "The AIRNET flight and weapons model approach and status was presented by Roger Branson. ... Mr. Branson cited that the Ft. Rucker site estimated that current processing capacity was approximately 90%. Although Mr. Branson felt that the AIRNET modifications would not cause frame overruns (15 Hz frames), he emphasized that inclusion of enhancements from other programs could max out the system. Mr. LaFoy requested that a measurement of the processing capacity be included in the ATP."

Inspection Method: The GT111 provide a user-selectable means of identifying time associated with processing. It is the keyboard option "U"; output is displayed on the GT111 System Console. Note that invocation of this option causes the Image Generator to "pause" momentarily while values are output. Option "U" provides timing information related to frame processing.

A test was conducted the week of 04/23/93 in the Loral WDL SDF to evaluate the system processing time required by both the baseline ATAC II executable (Version 1.0.0) and the ATAC II executable updated to include the Airnet Aeromodel Upgrades (Version 1.1.0). The test involved running a basic exercise scenario using each of the executables. Throughout each scenario the "U" option was exercised to identify the frame times. For each of the executables the frame times averaged 66 - 67 milliseconds (column 1 of the output generated at the selection of the "U" option). Thus there is no apparent increase in processing capacity due to the addition of the Airnet Aeromodel upgrades. Further analysis of the processing capacity is not achievable at this time due to the lack of a performance monitoring tool on the GT111.

VERIFIED: _____

TITLE: _____

CONCURRENCE: _____



3200 Zanker Rd.
P.O. Box 49041
San Jose, CA 95161-9041

DOC CODE ADST/WDL/TR-92-003029

Procedure No. **EXERCISE "C"**
TEST CASES 4&6

Page 1 of 50

CDRL NO. A009

TABLE OF CONTENTS PAGE NO.

REVISION HISTORY	2
TBD LIST	3
1.0 SCOPE	4
2.0 APPLICABLE DOCUMENTS	4
3.0 TEST ENVIRONMENT REQUIREMENTS	4
4.0 TEST PREPARATION	5
5.0 TEST PROCEDURE	10
6.0 NOTES	34
7.0 TEST FAILURES/INTERRUPTIONS	35
8.0 GLOSSARY	36
APPENDIX A	38
APPENDIX B	41
APPENDIX C	44

Test Start Time/Date		Test Complete Time/Date	
Prepared Under		Program	ADST/AIRNET RWA
Contract Number	N61339-91-D0001	Equipment Serial Number	N/A
Test Engineer	Date	Test Performed By	Date
Program Engineer	Date	Test Witnessed By	Date
Quality Assurance	Date	Customer Rep	Date
Program Office	Date	Data Reviewed By	Date
		Customer Rep	
Release Date			



3200 Zanker Rd.
P.O. Box 49041
San Jose, CA 95161-0041

Procedure No. EXERCISE 'C'
TEST CASES 4&6

Page 2 of 50

CDRL NO. A009

REVISION HISTORY

All revised or amended pages are listed below. Upon receipt, substitute pages of an amendment shall be inserted in the basic document after removal of the superseded pages. Revisions of test procedures shall be used as released.

REVISION	DATE	CHANGED BY	TYPE OF CHANGE OR REASON	PAGES AFFECTED

WDL 2070C

92321m.3a

11-92

[CC-2]



3200 Zanker
P.O. Box 49041
San Jose, CA 95161-9041

Procedure No. EXERCISE "C"
TEST CASES 4&6

Page 3 of 50

CDRL NO. A009

TBD LIST

All To Be Defined (TBD) items are listed below. Each item is identified by its associated page number and expected date of resolution.

TBD REFERENCE	PAGE AFFECTED	EXPECTED RESOLUTION
Missile Server Software Revision	6	

LORAL

3200 Zanker Rd.
P.O. Box 49041
San Jose, CA 95161-9041

Procedure No. EXERCISE "C"
TEST CASES 4 & 6

CDRL NO. A009

1.0 SCOPE

This document establishes the test procedure for demonstrating the capabilities as described by the requirements listed in Section 5.0 of this document. This test procedure provides for demonstrating Test Cases No. 4 & 6 as described in the AIRNET RWA Acceptance Test Plan and missile flyout handoff capabilities of the ATAC II RWA. The two test cases were combined to be efficiently demonstrated in one exercise, Exercise "C", as performed during this test.

2.0 APPLICABLE DOCUMENTS

The following documents of the issue shown form a part of the test procedure to the extent specified herein.

- a. Recommended Spares and Support Equipment, DI-V-30801
- b. MCC Operator's Manual, DI-MISC-80711
- c. AIRNET Data Handbook, March 14, 1986.
- d. System Specification for the Rotary Wing Aircraft AIRNET Aeromodel and Weapons Model Conversion, dated 6 June 1992.
- e. Statement of Work for the Acquisition of Rotary Wing Aircraft AIRNET Upgrades, dated 30 March 1992.
- f. AIRNET RWA Acceptance Test Plan, dated 1 Nov. 1992.
- g. DI-DRPR-81002, Developmental Design Drawings and Associated Lists.
- h. RWA System Integration Plan, August 5, 1992.
- i. Software Requirements Specification for Air to Air Combat (ATAC) II AIRNET Experiment, Revision 2.0, 04/10/92.

3.0 TEST ENVIRONMENT REQUIREMENTS

3.1 Test Conditions - Unless otherwise directed, tests shall be performed under ambient laboratory conditions of pressure, temperature, and humidity provided that the temperature is within the range of plus 10 to 40 degrees Celsius.

3.2 Test Witnessing - Test witnessing shall be provided by a representative of the LORAL WDL Quality Assurance and a designated representative of the receiving organization.

3.3 Measurements - Performance measurements are not applicable to this system level test but observations for validation of expected results will be recorded as specified in the test procedure.

3.4 Tolerance - Tolerance measurements are not applicable to this system level test. The tolerances used in the procedures are guidelines and not related to satisfying specific tolerance requirements.

4.0 TEST PREPARATION

4.1 Test Configuration - The following diagram reflects the hardware configuration required for this test. This test configuration is based on the San Jose System Development Facility (SDF) and may require modification when the test is executed at the Ft. Rucker facility. The basic components reflected in this block diagram are required at either facility in support of the execution of this test.

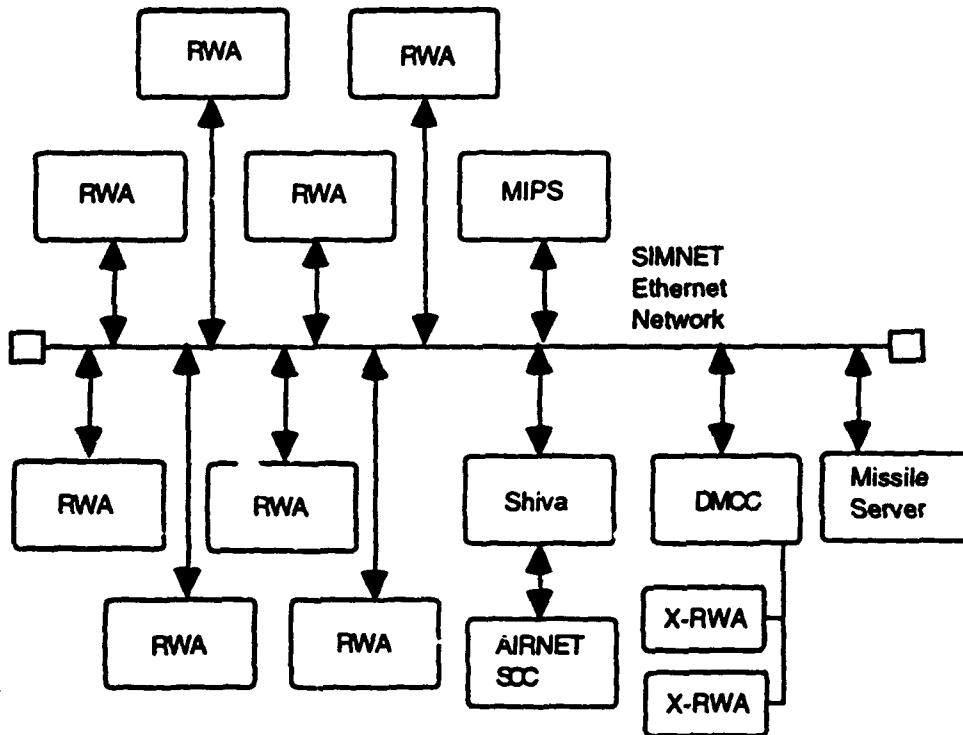

Figure 4.0 - 1 Required System Components

NOTE: This configuration is not available at the San Jose SDF which has only 1 RWA. This RWA is not configured with the upgraded collective mount, nor with the "communications kill" hardware. Thus full validation of this exercise at the SDF is prohibited.

The software configuration required for this test is as follows:

Software	Version
• AIRNET MIPS MCC Phantom	2.0.0
• AIRNET Mac SCC	1.0.0
• GT Operating System	GT 4.7 Apr. 9 13:35:35 PDT 1991
• GT Real Time Software	rttgr5.7
• Rotary Wing Aircraft (RWA)	1.1.0
• Digital Message Communications Console	1.6.2
• Missile Server	TBD

4.2 System Setup

The system set up procedures for this test are shown in Tables 4.2 - 1 through 4. Repeat the set up procedures identified in Table 4.2 - 1 for each of the eight (8) RWA simulators.

Table 4.2 - 1 Rotary Wing Aircraft Simulator Set Up

Action	()
Boot the RWA GT-111 Simulator	()
Verify the GT Operating System as GT 4.7	()
Download the RWA executable and data files	()
Calibrate the RWA simulator	()
Verify that the collective mount is in its most downward position	()
Verify that the communications kill switch is in the software controlled mode	()
Verify that the weapons arming switches are in the armed position	()
Initiate the real-time simulation software	()
Initiate the RWA executable with parameter file Knox.par, keyboard control exercise number 1, and the missile server active.	()

Table 4.2 - 2 AIRNET Management, Command and Control Console Set Up

<u>Action</u>	(√)
Download the MIPS Phantom process and data files	()
Load the Mac System Control Console software	()
Initiate the network process	()
Initiate the MIPS Phantom process using the Fort Knox Data Base	()
Initiate the AIRNET MCC System Control Console Software	()
Set up the AIRNET MCC to utilize the network	()

Table 4.2 - 3 Digital Message Console Set Up

<u>Action</u>	(√)
Initiate the DMCC software	()
Initiate a user interface for the TOC, FSE, RAH-66-1, and RAH-66-2	()
Log into a console and the network as the TOC, exercise 1	()
Set up an addressee of ALLRAHS and a location of ES950700	()
Log into a console and the network as the FSE, exercise 1	()
Set up an addressee of ALLRAHS	()
Log into a console and the network as the RAH-66-1, exercise 1	()
Set up a CEOI List of RAH-66-1 and ALLRAHS	()
Log into a console and the network as the RAH-66-2, exercise 1	()
Set up a CEOI List of RAH-66-2 and ALLRAHS	()

Table 4.2 - 4 Missile Server Set Up

<u>Action</u>	(√)
Initiate the Missile Server software	()

4.3 Test Requirements

The technical capabilities and skills required for this test are as follows:

- The optimum number of personnel for the conduct of this test is three (3); however it is possible to conduct this test with a single individual.
- The tester(s) are familiar with the operation of the RWA, including its Pilot and Co-Pilot/Gunner positions.
- The tester(s) are familiar with the operation of the AIRNET (MIPS-based) MCC.
- The tester(s) are familiar with the operation of the DMCC.
- The tester(s) are familiar with the operation of the Missile Server.

5.0 TEST PROCEDURE

Appendix A of this document, Exercise "C" Requirements Matrix, identifies the requirements to be validated during the execution of the test procedure as provided in this section. This step-by-step procedure provides for an indication on the success or failure of each step as it is executed.

5.1 Test Description - The basis for this test procedure is a simple exercise scenario and its set up, including measurement of the collective mount. This scenario incorporates communications between multiple RAH-66 Comanche aircraft. A top level description of the test procedure follows.

Eight rotary wing aircraft are allocated and initialized for the exercise. Three of the aircraft are involved in flight and/or communications and weapons fire. The remainder of the aircraft are not used. At various points within the exercise aircraft are flown, crashed and reconstituted. Communications modes are modified and communications attempted throughout.

5.2 Test Procedures - The test procedures which follow demonstrate requirement satisfaction while verifying the upgrade of the collective mount and communications system control within the existing AIRNET system.

After each step is performed, mark the status of the action as:

- S - Satisfactory with no anomaly.
- SA - Satisfactory with an anomaly indicated and documented.
- U - Unsatisfactory with an anomaly indicated and documented.

Note:

- (1) Requirements shown in standard face type are partially satisfied at the point within the test that they are referenced.
- (2) Requirements shown in bold face type are wholly satisfied at the point within the test that they are referenced.
- (3) References to a Battlemaster password of "foozball" are specific to the Loral WDL SDF. Should this test be run elsewhere, the correct Battlemaster password must be used.
- (4) This procedure does not attempt to follow standard Army operating procedures.
- (5) This exercise is assumed to be exercise 1.

5.2.1 Set Up Exercise at AIRNET System Control Console - The steps in this subparagraph consist of instructions for initializing the exercise number, the role of the Management, Command and Control Console, and the exercise's geographic area.

<u>Step</u>	<u>Operator/System Action</u>	<u>Expected Result</u>	<u>Status</u> (Check One)
10	At the Airnet SCC, start the exercise initialization process by clicking on the START button.	A display appears showing the exercise number, the MCC role, and the terrain to be used in the exercise.	<input checked="" type="checkbox"/> S <input type="checkbox"/> SA <input type="checkbox"/> U
20	Verify that the MCC is participating in Exercise 1.	The MCC is participating in Exercise 1.	<input checked="" type="checkbox"/> S <input type="checkbox"/> SA <input type="checkbox"/> U
30	Select the default role of the MCC to be US.	The display shows the default MCC role to be US.	<input checked="" type="checkbox"/> S <input type="checkbox"/> SA <input type="checkbox"/> U
40	Verify that the terrain to be used for the exercise is Fort Knox 8/14/90, SW corner: ES450550, NE corner: FT200050 Go to the NEXT menu.	An Overview menu is displayed showing the following selectable options: Simulator Allocation Simulator Activation Command Post Initialization Service Element Initialization Battlemaster	<input checked="" type="checkbox"/> S <input type="checkbox"/> SA <input type="checkbox"/> U

5.2.2 Set Up RWA Simulators as RAH-66 Comanches - The steps in this subparagraph consist of instructions for initializing 8 Fully Reconfigurable Devices (FRED) as RAH-66 Comanches.

<u>Step</u>	<u>Operator/System Action</u>	<u>Expected Result</u>	<u>Status</u> (Check One)
50	Select the Simulator Allocation Option and GO to the next menu.	A display appears showing the simulators available for allocation, including eight FRED simulators.	<input checked="" type="checkbox"/> S <input type="checkbox"/> SA <input type="checkbox"/> U
60	Highlight a FRED entry and click on the ALLOCATE button.	A display appears allowing element assignment.	<input checked="" type="checkbox"/> S <input type="checkbox"/> SA <input type="checkbox"/> U
70	Assign the entity to A Company by double clicking on US Army, then 223rd Attack Helo Battalion, then A Company.	The display shows the entity to be assigned to A Company.	<input checked="" type="checkbox"/> S <input type="checkbox"/> SA <input type="checkbox"/> U
80	Click on the ASSIGN button.	A display appears showing the simulators available for allocation, including the selected FRED which is now shown as assigned to A Company, but not yet placed.	<input checked="" type="checkbox"/> S <input type="checkbox"/> SA <input type="checkbox"/> U

- | | | |
|------------------------------------------------------------------------------------------------------------------------------------------------------------------------------------------|---------------------------------------------------------------------------------------------------------------------|----------------------------------------------------------------------------------------------|
| 90 Repeat entity assignment for the remaining 7 FRED simulators assigning 4 simulators to A Company and 4 to B Company. | The display shows 4 entities assigned to A Company, 4 to B Company, none of which are yet placed. | <input checked="" type="checkbox"/> S <input type="checkbox"/> SA <input type="checkbox"/> U |
| 100 Click on the Overview button. | The Overview menu is displayed. | <input checked="" type="checkbox"/> S <input type="checkbox"/> SA <input type="checkbox"/> U |
| 110 Select the Simulator Activation Option and GO to the next menu. | A display appears allowing simulator activation. | <input checked="" type="checkbox"/> S <input type="checkbox"/> SA <input type="checkbox"/> U |
| 120 Activate one of the simulators assigned to A Company in A Company by double clicking on US Army, then 223rd Attack Helo Battalion, then A Company. | The display shows the simulator to be activated in A Company. | <input checked="" type="checkbox"/> S <input type="checkbox"/> SA <input type="checkbox"/> U |
| 130 Set a default location of ES950550 and verify that the default force is US. Go to the NEXT menu. | A display appears showing the activated simulators. The selected FRED is assigned to A Company, but not yet placed. | <input checked="" type="checkbox"/> S <input type="checkbox"/> SA <input type="checkbox"/> U |
| 140 Highlight the selected FRED entry by clicking on the entry and go to the NEXT menu. | A display appears allowing simulator customization. | <input checked="" type="checkbox"/> S <input type="checkbox"/> SA <input type="checkbox"/> U |
| 150 Customize the selected FRED with a tail number of 1, a location of ES950600, a heading of 0, an alignment of US, a maintenance status of New, and a vehicle type of RAH-66 Comanche. | The display reflects the custom selections. | <input checked="" type="checkbox"/> S <input type="checkbox"/> SA <input type="checkbox"/> U |
| 160 Verify that the default weapons load is:
4 Hellfire Missiles
2 Stingers
0 Hydra 70 M151 (10 lb.)
320 rounds 20 mm HEI
0 rounds 20 mm PIE | The display reflects the custom selections and a default weapons load. | <input checked="" type="checkbox"/> S <input type="checkbox"/> SA <input type="checkbox"/> U |
| 170 Verify that the default fuel load is:
1690 lbs. | The display reflects the custom selections and a default fuel load. | <input checked="" type="checkbox"/> S <input type="checkbox"/> SA <input type="checkbox"/> U |
| 180 Select the fuel entry and specify a fuel load of 1500 lbs. | The display reflects the custom fuel selection. | <input checked="" type="checkbox"/> S <input type="checkbox"/> SA <input type="checkbox"/> U |
| 190 Select the Hellfire missiles entry and specify a weapons load of 6 Hellfire missiles. | The display reflects the custom Hellfire selection. | <input checked="" type="checkbox"/> S <input type="checkbox"/> SA <input type="checkbox"/> U |

- | | | | |
|-----|-----------------------------------------------------------------------------------------------------------------------------------------------------|-------------------------------------------------------------------------------------------------------------------------------------------------------------------------------------------------------|------------------------------------------------------------------------------------------------------|
| 200 | Select the Hydra entry and specify a weapons load of 30. | The display reflects the custom Hydra selection. | <input checked="" type="checkbox"/> S <input type="checkbox"/> SA <input type="checkbox"/> U |
| 210 | Select the ACTIVATE button. | A display appears showing the activated simulators. The selected FRED is assigned to A Company, placed.
The RWA is activated as an RAH-66 Comanche, the image generator visuals and sound come on. | <input checked="" type="checkbox"/> S <input type="checkbox"/> SA <input type="checkbox"/> U |
| 220 | At the FRED device, set the radio communications switch to the state associated with software control of the radio communications system (COMM ON). | The radio is set to be software controlled.
•3.2.1.6.1
•3.2.1.6.1.1 | <input checked="" type="checkbox"/> S <input type="checkbox"/> SA <input type="checkbox"/> U |
| 230 | Repeat entity activation and communications state initialization for the remaining 7 FRED simulators using the parameters shown in the table below. | The display shows 8 activated simulators. Each of the RWAs is activated as an RAH-66 Comanche, the image generator visuals and sound come on.
•3.2.1.1.1.10 (8 sims) | <input type="checkbox"/> S <input checked="" type="checkbox"/> SA <input type="checkbox"/> U
FR-9 |
| 240 | Click on the Overview button. | The Overview menu is displayed. | <input checked="" type="checkbox"/> S <input type="checkbox"/> SA <input type="checkbox"/> U |

Entity Activation Parameters for 7 FREDs

FRED/ Tail #	Location	Heading	Weapons	Fuel	For all Aircraft
82	ES951600	0	8 Hellfire Missiles 2 Stingers 20 Hydra 70 M151 (10 lb.)	1600	Default Location: ES950550 Alignment: US Maintenance Status: New Vehicle Type: RAH-66 Radio Comm System: COMM ON (Software Controlled)
83	ES952600	0	defaults	1500	
84	ES953600	0	defaults	1600	
85	ES950580	0	defaults	1400	
86	ES950580	160 0	defaults	1200	
87	ES950560	0	defaults	1600	
88	ES95005601	160 0	defaults	1600	

5.2.3 Set Up Targets - The steps in this subparagraph consist of instructions for initializing the Gunnery Targets.

Step	Operator/System Action	Expected Result	Status (Check One)
250	Select the Battlemaster Functions Option and GO to the next menu.	A display appears requesting the Battlemaster password.	<input checked="" type="checkbox"/> S <input type="checkbox"/> SA <input type="checkbox"/> U
260	Enter the Battlemaster password (foozball) and click on the OK button.	The Battlemaster Overview menu is displayed showing the following selectable options: Displacement Reconstitute Gunnery Targets Resume Initialization End Exercise	<input checked="" type="checkbox"/> S <input type="checkbox"/> SA <input type="checkbox"/> U
270	Select the Gunnery Targets Option and GO to the next menu.	A Gunnery Targets list (empty) is displayed.	<input checked="" type="checkbox"/> S <input type="checkbox"/> SA <input type="checkbox"/> U
280	Enter the gunnery targets as: Target 1, Attack RWA, Defense, ES970630 Target 2, Attack RWA, Defense, ES970631 Target 3, Attack RWA, Defense, ES970632 Target 4, Attack RWA, Defense, ES970633 and click on the Overview button.	The Battlemaster Overview menu is displayed.	<input checked="" type="checkbox"/> S <input type="checkbox"/> SA <input type="checkbox"/> U

5.2.4 Verify Aircraft Positions - The steps in this subparagraph consist of instructions for verifying the positional location of the RAH-66 Comanche aircraft at activation.

Step	Operator/System Action	Expected Result	Status (Check One)
290	<p>At each RWA System Console (gt-1), enter < (less than sign) to display the vehicle's location. Record the values displayed.</p> <p>FRED #1: X <u>5000.5</u> Y <u>5000.4</u> Z <u>201.4</u> UTM <u>ES950400</u></p> <p>FRED #2: X <u>5000.9</u> Y <u>5000.4</u> Z <u>200.9</u> UTM <u>ES951600</u></p> <p>FRED #3: X <u>5000.0</u> Y <u>5000.4</u> Z <u>200.2</u> UTM <u>ES952600</u></p> <p>85 FRED 4: X <u>50050</u> Y <u>25139.9</u> Z <u>251.6</u> UTM <u>ES951801</u></p> <p>85 FRED 5: X <u>50020.0</u> Y <u>3000.4</u> Z <u>ES950580</u> UTM <u>ES950580</u></p> <p>86 FRED 6: X <u>5000.46</u> Y <u>3000.596</u> Z <u>214.47</u> UTM <u>ES950580</u></p> <p>87 FRED 7: X <u>5000.5</u> Y <u>10000.4</u> Z <u>202.45</u> UTM <u>950650</u></p> <p>FRED 8: X _____ Y _____ Z _____ UTM _____</p>	<p>The X,Y,Z and UTM coordinates of each aircraft's location is displayed.</p> <p>FRED 1: ES950800 => (50000, 5000)</p> <p>FRED 2: ES951600 => (50100, 5000)</p> <p>FRED 3: ES952600 => (50200, 5000)</p> <p>FRED 4: ES953600 => (50300, 5000)</p> <p>FRED 5 & 6 (Originally): ES950580 => (50000, 3000)</p> <p>FRED 7: ES950560 => (50000, 1000)</p> <p>FRED 8 (Originally): ES95005601 => (50000,1010)</p> <p>The values for FRED 6 and FRED 8 are different than those originally specified. (X and Y values are in meters.)</p>	<p><input type="checkbox"/> S <input checked="" type="checkbox"/> SA <input type="checkbox"/> U</p>
300	<p>Examine the simulated vehicle positions and verify that the simulated vehicles do not occupy the same position.</p>	<p>No two simulated vehicles occupy the same position. *3.2.1.1.1.12</p>	<p><input checked="" type="checkbox"/> S <input type="checkbox"/> SA <input type="checkbox"/> U</p>

alt →
new

214.46

ES95058014

FTR-9

- 310 Examine the simulated vehicle positions and verify that the position of vehicle FRED 5 is 33 or more meters apart from vehicle FRED 6. FRED 5 is at least 33 meters from FRED 6. S SA U
 •3.2.1.1.1.13
FTR-8 has been generated to reflect only 30 meters
- 320 Verify that the position of vehicle FRED 7 is 33 or more meters apart from vehicle FRED 8. FRED 7 is at least 33 meters from FRED 8. S SA U
 •3.2.1.1.1.13

5.2.5 Transmit Free Text Digital Messages to RAH-66 Comanche Aircraft - The steps in this subparagraph consist of instructions for sending free text digital messages between the TOC or FSE and the RAH-66 aircraft.

Step	Operator/System Action	Expected Result	Status (Check One)
330	At the TOC DMCC, select the Report (RPRT) option from the System Main Menu (SYS MAIN) by clicking on the bezel switch.	The Report (RPRT) Menu is displayed identifying the types of messages which may be sent.	<input checked="" type="checkbox"/> S <input type="checkbox"/> SA <input type="checkbox"/> U
340	Select the Free Text (FREE TXT) message option by clicking on the bezel switch.	A Free Text message display appears showing the entries which may be made in a Free Text message.	<input checked="" type="checkbox"/> S <input type="checkbox"/> SA <input type="checkbox"/> U
350	Select the Address (ADRS) of all RAH-66s (ALLRAHS) by clicking on the bezel switch until the entry is highlighted.	The ALLRAHS address is highlighted.	<input checked="" type="checkbox"/> S <input type="checkbox"/> SA <input type="checkbox"/> U
360	Enter the following in the free text area: Exercise has commenced.	The text is displayed as entered.	<input checked="" type="checkbox"/> S <input type="checkbox"/> SA <input type="checkbox"/> U
370	Send the Free Text message by clicking on the Send Routine (SND ROUT) button.	The button is momentarily highlighted. •3.2.1.2.2.2.2 (TOC)	<input checked="" type="checkbox"/> S <input type="checkbox"/> SA <input type="checkbox"/> U
380	Click on the CLEAR and RETURN button.	The display returns to the Report (RPRT) Menu.	<input checked="" type="checkbox"/> S <input type="checkbox"/> SA <input type="checkbox"/> U
390	Click on the SYS MAIN button.	The display returns to the System Main (SYS MAIN) Menu.	<input checked="" type="checkbox"/> S <input type="checkbox"/> SA <input type="checkbox"/> U

- | | | |
|----------------------------------------------------------------------------------------------------------------------------|---------------------------------------------------------------------------------------------------|----------------------------------------------------------------------------------------------|
| 400 At the FSE DMCC, select the Report (RPRT) option from the System Main Menu (SYS MAIN) by clicking on the bezel switch. | The Report (RPRT) Menu is displayed identifying the types of messages which may be sent. | <input checked="" type="checkbox"/> S <input type="checkbox"/> SA <input type="checkbox"/> U |
| 410 Select the Free Text (FREE TXT) message option by clicking on the bezel switch. | A Free Text message display appears showing the entries which may be made in a Free Text message. | <input checked="" type="checkbox"/> S <input type="checkbox"/> SA <input type="checkbox"/> U |
| 420 Select the Address (ADRS) of all RAH-66s (ALLRAHS) by clicking on the bezel switch until the entry is highlighted. | The ALLRAHS address is highlighted. | <input checked="" type="checkbox"/> S <input type="checkbox"/> SA <input type="checkbox"/> U |
| 430 Enter the following in the free text area:

Standby for orders. | The text is displayed as entered. | <input checked="" type="checkbox"/> S <input type="checkbox"/> SA <input type="checkbox"/> U |
| 440 Send the Free Text message by clicking on the Send Routine (SND ROUT) button. | The button is momentarily highlighted.
*3.2.1.2.2.2.2 (FSE) | <input checked="" type="checkbox"/> S <input type="checkbox"/> SA <input type="checkbox"/> U |
| 450 Click on the CLEAR and RETURN button. | The display returns to the Report (RPRT) Menu. | <input checked="" type="checkbox"/> S <input type="checkbox"/> SA <input type="checkbox"/> U |
| 460 Click on the SYS MAIN button. | The display returns to the System Main (SYS MAIN) Menu. | <input checked="" type="checkbox"/> S <input type="checkbox"/> SA <input type="checkbox"/> U |
| 470 At the RAH-66-1 DMCC, verify the display of an incoming message icon box | The incoming message icon ^{box} disappears. | <input checked="" type="checkbox"/> S <input type="checkbox"/> SA <input type="checkbox"/> U |

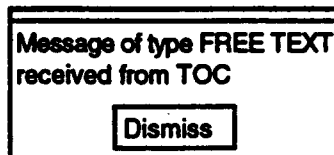

and dismiss the ~~icon~~^{box} by clicking on the Dismiss button. ~~box~~

- 480 Verify the display of an incoming message icon box.

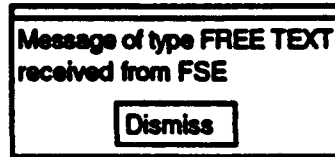

and dismiss the icon by clicking on the Dismiss button.

The incoming message icon box disappears.

S SA U

- 490 Select the Message (MSG) option from the System Main (SYS MAIN) Menu by clicking on the bezel switch.

The Message (MSG) Menu is displayed identifying the messages presently in the queue. There queue shows two messages, one from the TOC and one from the FSE.

S SA U

- 500 Select the Free Text message received from the TOC by clicking on the PREV/NEXT bezel switches.

The message entry is highlighted.

S SA U

- 510 Retrieve and display the message by clicking on the READ button.

The selected message is displayed.

S SA U

- 520 Verify the message contents:
 FREE TEXT MESSAGE ROUTINE
 SENDER TOC
 SENT TO ALLRAHS
 FWD BY
 MSG SENT (date/time)
 XMIT LCN
 XMIT ALT 0 FEET

The message content is as specified.

S SA U

Exercise has commenced.

where date/time is of the format
 26 1745 JUNE 95.

- 530 Click on the READ button to return to the Message Queue display.

The display returns to the Message Queue display.

S SA U

- 540 Select the Free Text message received from the FSE by clicking on the PREV/NEXT bezel switches until the entry is highlighted.

The message entry is highlighted.

S SA U

- 550 Retrieve and display the message by clicking on the READ button.

The selected message is displayed.

S SA U

560 Verify the message contents:
FREE TEXT MESSAGE ROUTINE
SENDER FSE
SENT TO ALLRAHS
FWD BY
MSG SENT (date/time)
XMIT LCN
XMIT ALT 0 FEET

The message content is as specified.

S SA U

Standby for orders.

where date/time is of the format
26 1745 JUNE 95.

570 Click on the SYS MAIN button.

The display returns to the System
Main (SYS MAIN) Menu.

S SA U

580 Repeat Steps ⁴⁷⁰ ~~430~~ through ⁵⁷⁰ ~~530~~
at the RAH-66-2 DMCC.

The messages are correctly
received by RAH-66-2.

S SA U

590 At the TOC DMCC, verify the
display of a Message
Acknowledgment from RAH-66-2

The message acknowledgment
disappears.

S SA U

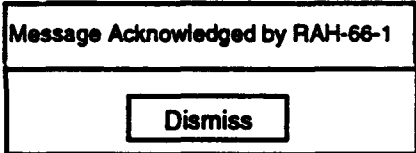

and dismiss the icon by clicking on
the Dismiss button. *box*

600 Verify the display of a Message
Acknowledgment from RAH-66-2

The message acknowledgment
disappears.

S SA U

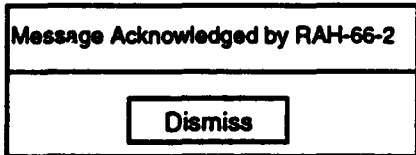

and dismiss the icon by clicking on
the Dismiss button. *box*

- 610 At the FSE DMCC, verify the display of a Message Acknowledgment from RAH-66-1

The message acknowledgement disappears.

S SA U

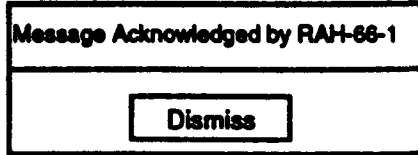

and dismiss the icon by clicking on the Dismiss button.

- 620 Verify the display of a Message Acknowledgment from RAH-66-2

The message acknowledgement disappears.

S SA U

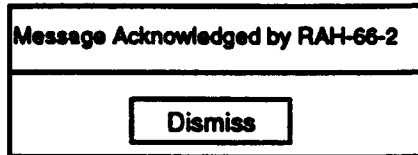

and dismiss the icon by clicking on the Dismiss button.

5.2.6 Transmit Pre-Formatted Digital Messages to RAH-66 Comanche Aircraft - The steps in this subparagraph consist of instructions for sending Pre-Formatted digital messages between the TOC or FSE and the RAH-66 aircraft.

<u>Step</u>	<u>Operator/System Action</u>	<u>Expected Result</u>	<u>Status</u> (Check One)
630	At the TOC DMCC, select the Report (RPRT) option from the System Main Menu (SYS MAIN) by clicking on the bezel switch.	The Report (RPRT) Menu is displayed identifying the types of messages which may be sent.	<input checked="" type="checkbox"/> S <input type="checkbox"/> SA <input type="checkbox"/> U
640	Select the Move Command (MOVCMD) message option by clicking on the bezel switch.	A Move Command message display appears showing the entries which may be made in a Move Command message.	<input checked="" type="checkbox"/> S <input type="checkbox"/> SA <input type="checkbox"/> U
650	Select the Address (ADRS) of all RAH-66s (ALLRAHS) by clicking on the bezel switch until the entry is highlighted.	The ALLRAHS address is highlighted.	<input checked="" type="checkbox"/> S <input type="checkbox"/> SA <input type="checkbox"/> U
660	Select the task as Move To (MOV TO) by clicking on the bezel switch until the entry is highlighted.	The MOV TO task entry is highlighted.	<input checked="" type="checkbox"/> S <input type="checkbox"/> SA <input type="checkbox"/> U

- | | | | | | |
|-----|-------------------------------------------------------------------------------------------------------------------------------|-----------------------------------------------------------------------------------------------|------------------------------------------|--------------------------------|-------------------------------|
| 670 | Select When as When Ready (WHN RDY) by clicking on the bezel switch until the entry is highlighted. | The WHN RDY entry is highlighted. | <input checked="" type="checkbox"/>
S | <input type="checkbox"/>
SA | <input type="checkbox"/>
U |
| 680 | Select the Location (LCTN) as ES950700 by clicking on the bezel switch until the entry is highlighted. | The ES950700 entry is highlighted. | <input checked="" type="checkbox"/>
S | <input type="checkbox"/>
SA | <input type="checkbox"/>
U |
| 690 | Select Who as YOU by clicking on the bezel switch until the entry is highlighted. | The YOU entry is highlighted. | <input checked="" type="checkbox"/>
S | <input type="checkbox"/>
SA | <input type="checkbox"/>
U |
| 700 | Send the message by clicking on the Send Routine (SND ROUT) button. | The button is momentarily highlighted.
•3.2.1.2.2.2.1 (TOC) | <input checked="" type="checkbox"/>
S | <input type="checkbox"/>
SA | <input type="checkbox"/>
U |
| 710 | Click on the CLEAR and RETURN button. | The display returns to the Report (RPRT) Menu. | <input checked="" type="checkbox"/>
S | <input type="checkbox"/>
SA | <input type="checkbox"/>
U |
| 720 | Click on the SYS MAIN button. | The display returns to the System Main (SYS MAIN) Menu. | <input checked="" type="checkbox"/>
S | <input type="checkbox"/>
SA | <input type="checkbox"/>
U |
| 730 | At the FSE DMCC, select the Report (RPRT) option from the System Main Menu (SYS MAIN) by clicking on the bezel switch. | The Report (RPRT) Menu is displayed identifying the types of messages which may be sent. | <input checked="" type="checkbox"/>
S | <input type="checkbox"/>
SA | <input type="checkbox"/>
U |
| 740 | Select the Request (REQUEST) message option by clicking on the bezel switch. | A Request message display appears showing the entries which may be made in a Request message. | <input checked="" type="checkbox"/>
S | <input type="checkbox"/>
SA | <input type="checkbox"/>
U |
| 750 | Select the Address (ADRS) of all RAH-66s (ALLRAHS) by clicking on the bezel switch until the entry is highlighted. | The ALLRAHS address is highlighted. | <input checked="" type="checkbox"/>
S | <input type="checkbox"/>
SA | <input type="checkbox"/>
U |
| 760 | Select the Type (TYPE) as RECON by clicking on the bezel switch until the entry is highlighted. | The RECON entry is highlighted. | <input checked="" type="checkbox"/>
S | <input type="checkbox"/>
SA | <input type="checkbox"/>
U |
| 770 | Select the Reconnaissance (RECON TYPE) as Air Route (AIR RTE) by clicking on the bezel switch until the entry is highlighted. | The AIR RTE entry is highlighted. | <input checked="" type="checkbox"/>
S | <input type="checkbox"/>
SA | <input type="checkbox"/>
U |
| 780 | Send the message by clicking on the Send Routine (SND ROUT) button. | The button is momentarily highlighted.
•3.2.1.2.2.2.1 (FSE) | <input checked="" type="checkbox"/>
S | <input type="checkbox"/>
SA | <input type="checkbox"/>
U |

790 Click on the CLEAR and RETURN button.

The display returns to the Report (RPRT) Menu.

S SA U

800 Click on the SYS MAIN button.

The display returns to the System Main (SYS MAIN) Menu.

S SA U

810 At the RAH-66-1 DMCC, verify the display of an incoming message ~~icon~~ *box*

The incoming message ~~icon~~ *box* disappears.

S SA U

Message of type MOVE
received from TOC

Dismiss

and dismiss the ~~icon~~ *box* by clicking on the Dismiss button. *box*

820 Verify the display of an incoming message ~~icon~~ *box*

The incoming message ~~icon~~ *box* disappears.

S SA U

Message of type REQUEST
received from FSE

Dismiss

and dismiss the ~~icon~~ *box* by clicking on the Dismiss button. *box*

830 Select the Message (MSG) option from the System Main (SYS MAIN) Menu by clicking on the bezel switch.

The Message (MSG) Menu is displayed identifying the messages presently in the queue. The queue shows two messages, one from the TOC and one from the FSE.

S SA U

840 Select the Move Command message received from the TOC by clicking on the PREV/NEXT bezel switches until the entry is highlighted.

The message entry is highlighted.

S SA U

850 Retrieve and display the message by clicking on the READ button.

The selected message is displayed.

S SA U

**THIS
PAGE
IS
MISSING
IN
ORIGINAL
DOCUMENT**

23

[CC-23]

930 At the TOC DMCC, verify the display of a Message Acknowledgment from RAH-66-1

The message acknowledgment disappears.

S SA U

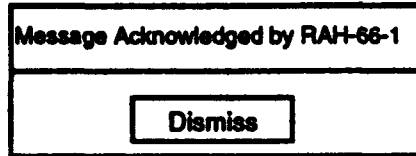

and dismiss the icon by clicking on the Dismiss button. *bax*

940 Verify the display of a Message Acknowledgment from RAH-66-2

The message acknowledgment disappears.

S SA U

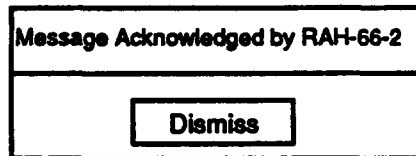

and dismiss the icon by clicking on the Dismiss button. *bax*

950 At the FSE DMCC, verify the display of a Message Acknowledgment from RAH-66-1

The message acknowledgment disappears.

S SA U

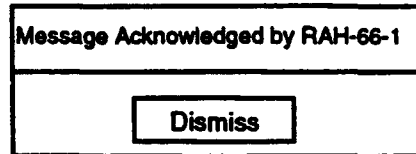

and dismiss the icon by clicking on the Dismiss button. *bax*

960 Verify the display of a Message Acknowledgment from RAH-66-2

The message acknowledgment disappears.

S SA U

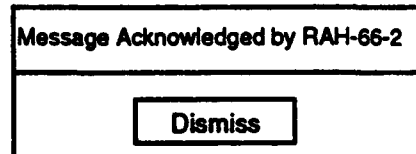

and dismiss the icon by clicking on the Dismiss button. *bax*

5.2.7 Set up Laser Codes and Verify Radio Communications Between AIRNET Vehicles - The steps in this subparagraph consist of instructions for establishing laser codes and verifying that the communications mode has been initialized to be on and that two-way radio communications are possible between vehicles.

<u>Step</u>	<u>Operator/System Action</u>	<u>Expected Result</u>	<u>Status</u> (Check One)		
970	At the RAH-66 1 softpanel, set the mode to be used by the laser rangefinder/ designator to laser code mode, laser code A.	The Situational Display reflects the choice of laser code mode, laser code A.	<input checked="" type="checkbox"/> S	<input type="checkbox"/> SA	<input type="checkbox"/> U
980	Modify laser code A to have a value of 4321.	Laser code A is modified to have a value of 4321. •ATAC II - 3.3.1.30.1	<input checked="" type="checkbox"/> S	<input type="checkbox"/> SA	<input type="checkbox"/> U
990	Modify laser code G to have a value of 7777.	Laser code G is modified to have a value of 7777. The remaining laser codes, B,C,D,E,F and H have no value. •ATAC II - 3.3.1.8	<input checked="" type="checkbox"/> S	<input type="checkbox"/> SA	<input type="checkbox"/> U
1000	Select laser code G as the secondary code by hitting the toggle key (keypad 4th row, 4th column) until code G is selected.	Laser code G is the secondary laser code. •ATAC II - 3.3.1.16.2 •ATAC II - 3.3.1.30.1	<input checked="" type="checkbox"/> S	<input type="checkbox"/> SA	<input type="checkbox"/> U
1010	Select laser code G as the primary code by hitting the toggle key (keypad 4th row, 4th column) until code G is selected.	Laser code G is the primary laser code. •ATAC II - 3.3.1.16.1	<input checked="" type="checkbox"/> S	<input type="checkbox"/> SA	<input type="checkbox"/> U
1020	Toggle between normal mode and laser code mode and back by using the toggle key (keypad 4th row, 3rd column) ending in laser code mode.	The mode toggles between laser code mode, normal mode and laser code mode. •ATAC II - 3.3.1.9 •ATAC II - 3.3.1.30.4	<input checked="" type="checkbox"/> S	<input type="checkbox"/> SA	<input type="checkbox"/> U
1030	Toggle between the primary laser code and the secondary laser code and back again.	The selection toggles between the primary and secondary codes. •ATAC II - 3.3.1.16.3 •ATAC II - 3.3.1.30.3	<input checked="" type="checkbox"/> S	<input type="checkbox"/> SA	<input type="checkbox"/> U
1040	At the RAH-66 1 radio, send the message ("Using primary laser code G7777 for Targets 1 - 4.") to RAH-66 aircraft 2.	The message is transmitted to RAH-66 2 aircraft. •3.2.1.6.2.1 (one-way)	<input checked="" type="checkbox"/> S	<input type="checkbox"/> SA	<input type="checkbox"/> U

- | | | | |
|------|------------------------------------------------------------------------------------------------------------------------------------------------|----------------------------------------------------------------------------|----------------------------------------------------------------------------------------------|
| 1050 | At the RAH-66 2 aircraft, use the radio to send a message ("Roger, using primary laser code G7777 for Targets 1 - 4.") to RAH-66 aircraft 1. | The message is received by RAH-66 1 aircraft.
•3.2.1.6.2.1 (two-way) | <input checked="" type="checkbox"/> S <input type="checkbox"/> SA <input type="checkbox"/> U |
| 1060 | At the RAH-66 1 aircraft, use the radio to send a message ("Coordinated laser codes for Targets 1 - 4 with aircraft 2.") to RAH-66 aircraft 3. | The message is transmitted to RAH-66 3 aircraft. | <input checked="" type="checkbox"/> S <input type="checkbox"/> SA <input type="checkbox"/> U |
| 1070 | At the RAH-66 3 aircraft, use the radio to send a message ("Roger.") to RAH-66 aircraft 1. | The message is received by RAH-66 1 aircraft.
•3.2.1.6.2.1 (2-way, vch) | <input checked="" type="checkbox"/> S <input type="checkbox"/> SA <input type="checkbox"/> U |
| 1080 | At the RAH-66 2 softpanel, modify the laser code value for laser code G to 7777. | The Situational Display reflects the value of laser code mode G as 7777. | <input checked="" type="checkbox"/> S <input type="checkbox"/> SA <input type="checkbox"/> U |
| 1090 | Select laser code G as the primary code by hitting the toggle key (keypad 4th row, 4th column) until code G is selected. | Laser code G is the primary laser code. | <input checked="" type="checkbox"/> S <input type="checkbox"/> SA <input type="checkbox"/> U |

5.2.8 Fly Aircraft to Target Area and Fire Hellfire Missiles - The steps in this subparagraph consist of instructions for flying aircrafts 1 and 2 and firing hellfire missiles using a remote laser designator. Aircraft 1 serves as the remote laser designator, aircraft 2 fires the hellfire missile.

<u>Step</u>	<u>Operator/System Action</u>	<u>Expected Result</u>	<u>Status</u> (Check One)
1100	At the RAH-66 1, take off and hover at an altitude of 1500 ft.	The aircraft takes off and hovers.	<input checked="" type="checkbox"/> S <input type="checkbox"/> SA <input type="checkbox"/> U
1110	At the RAH-66 2 ^(S2) softpanel, enter a waypoint at ES950630 and select it for navigation.	The Situational Display shows the entered waypoint, its heading (East) and range (3000 m.). N	<input checked="" type="checkbox"/> S <input type="checkbox"/> SA <input type="checkbox"/> U
1120	Fly the aircraft to the waypoint and hover at an altitude of 1000 ft. with a heading of 0 degrees.	The aircraft flies to the waypoint and hovers.	<input checked="" type="checkbox"/> S <input type="checkbox"/> SA <input type="checkbox"/> U
1130	At the RAH-66 2 CPG position, select the Hellfire missile by moving the Weapons Action Switch to the right.	The Weapons Selection Indicator is lit green for CPG control of Missile (MSL) 1.	<input checked="" type="checkbox"/> S <input type="checkbox"/> SA <input type="checkbox"/> U

1140 Using the radio, send a message to RAH-66 1 indicating arrival at the waypoint and requesting lasing. The message is received by RAH-66 1. S SA U

1150 At the RAH-66 1, send a message to RAH-66 2 indicating that lasing is begun. The message is received by RAH-66 2. S SA U

1160 At the RAH-66 1 CPG position, lase the target associated with laser code G. Verify the display of the laser code and range on the sensor display. The sensor display indicates the laser code G plus the four digit range field (with leading zero, 5 digits total) and that the laser is on. The range is displayed only for 10 seconds. The laser code and range are displayed near the bottom of the display in the same row and to the left of the TOF symbology.
 •ATAC II - 3.3.1.20
 •ATAC II - 3.3.1.22

1170 At the RAH-66 2 pilot position, move the aircraft until it is within the firing constraints. The reticle on the CPG sensor display converts from out of constraint form to in constraint form when transitioning. Note that the vehicle may already be positioned such that it is within firing constraints. S SA U

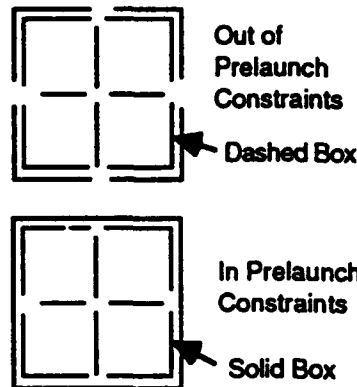

- | | | |
|-------------------------------------------------------------------------------------------------------|----------------------------------------------------------------------------------------------------------------------------------------------------|----------------------------------------------------------------------------------------------|
| 1180 At the RAH-66 2 CPG position, pull the weapons trigger to fire the missile. | The missile is fired and travels to the location indicated by the remotely designated laser.
•ATAC II - 3.3.1.13 (Rem)
See Note 1 Appendix A | <input checked="" type="checkbox"/> S <input type="checkbox"/> SA <input type="checkbox"/> U |
| 1190 Deselect the Hellfire missile by moving the Weapons Action Switch to the right. | The Weapons Selection Indicator is not lit for Missile (MSL) 1. | <input checked="" type="checkbox"/> S <input type="checkbox"/> SA <input type="checkbox"/> U |
| 1200 At the RAH-66 2 pilot position, land the aircraft. | The aircraft lands. | <input checked="" type="checkbox"/> S <input type="checkbox"/> SA <input type="checkbox"/> U |
| 1210 At the RAH-66 1 CPG position, discontinue lasing the target when the fired missile has impacted. | The target is hit and lasing is discontinued. | <input checked="" type="checkbox"/> S <input type="checkbox"/> SA <input type="checkbox"/> U |

5.2.9 Crash Aircraft 1 to Kill Communications - The steps in this subparagraph consist of instructions for crashing the aircraft (i.e. changing the communications mode to COMM OFF).

- | <u>Step</u> | <u>Operator/System Action</u> | <u>Expected Result</u> | <u>Status</u>
(Check One) |
|-------------|---------------------------------------------------------------------------------------------------------------------------|--------------------------------------------------------------------------------|----------------------------------------------------------------------------------------------|
| 1220 | At the RAH-66 1 pilot position, point the nose of the aircraft towards the ground and descend until the vehicle crashes. | The aircraft crashes into the ground. | <input checked="" type="checkbox"/> S <input type="checkbox"/> SA <input type="checkbox"/> U |
| 1230 | Put the collective mount in its most downward position. | The collective mount is at its most downward position. | <input checked="" type="checkbox"/> S <input type="checkbox"/> SA <input type="checkbox"/> U |
| 1240 | Using the radio, send a message ("MESSAGE FROM AIRCRAFT 1 to AIRCRAFT 2" to RAH-66 aircraft 2. | The message is NOT transmitted to RAH-66 2 aircraft.
•3.2.1.6.2.2 (one-way) | <input checked="" type="checkbox"/> S <input type="checkbox"/> SA <input type="checkbox"/> U |
| 1250 | At the RAH-66 2 aircraft, use the radio to send a message ("MESSAGE FROM AIRCRAFT 2 to AIRCRAFT 1") to RAH-66 aircraft 1. | The message is NOT received by RAH-66 1 aircraft.
•3.2.1.6.2.2 (two-way) | <input checked="" type="checkbox"/> S <input type="checkbox"/> SA <input type="checkbox"/> U |
| 1260 | At the RAH-66 1 aircraft, use the radio to send a message ("MESSAGE FROM AIRCRAFT 1 to AIRCRAFT 3") to RAH-66 aircraft 3. | The message is NOT transmitted to RAH-66 3 aircraft. | <input checked="" type="checkbox"/> S <input type="checkbox"/> SA <input type="checkbox"/> U |

- 1270 At the RAH-66 3 aircraft, use the radio to send a message ("MESSAGE FROM AIRCRAFT 3 to AIRCRAFT 1") to RAH-66 aircraft 1. The message is NOT received by RAH-66 2 aircraft. •3.2.1.6.2.2 (2-way, vehs)
- S SA U

5.2.10 Reconstitute Aircraft 1 and Inform Aircrafts 2 & 3 Via Radio - The steps in this subparagraph consist of instructions for reconstituting the crashed aircraft and sending associated radio communications. Reconstitution reactivates radio capabilities in the software controlled mode.

<u>Step</u>	<u>Operator/System Action</u>	<u>Expected Result</u>	<u>Status</u> (Check One)
1280	At the AIRNET SCC, select the Battlemaster Functions option and GO to the next menu.	A display appears requesting the Battlemaster password.	<input checked="" type="checkbox"/> S <input type="checkbox"/> SA <input type="checkbox"/> U
1290	Enter the Battlemaster password (foozball) and click on the OK button.	The Battlemaster Overview menu is displayed showing the following selectable options: Displacement Reconstitute Gunnery Targets Resume Initialization End Exercise	<input checked="" type="checkbox"/> S <input type="checkbox"/> SA <input type="checkbox"/> U
1300	Select the Reconstitute Option and GO to the next menu.	A display allowing reconstitution appears.	<input checked="" type="checkbox"/> S <input type="checkbox"/> SA <input type="checkbox"/> U
1310	Reset the aircraft's location to ES960600 and its heading to 4800 mils (270 degrees - East).	The display reflects the modified location and heading.	<input checked="" type="checkbox"/> S <input type="checkbox"/> SA <input type="checkbox"/> U
1320	Click on the RECONSTITUTE button.	The display returns to the Battlemaster OVERVIEW menu and the RAH-66 1 RWA is reconstituted at the specified location and heading. The communications state is COMM ON. 3.2.1.1.2.9 (mcc notify)	<input checked="" type="checkbox"/> S <input type="checkbox"/> SA <input type="checkbox"/> U

- | | | |
|-------------------------------------------------------------------------------------------------------------------------------------------------------------------------------------------------------------------------------------------------------------|--------------------------------------------------------------------------------------------------------------------------------------------------------------------------------------|-----------------------------------------------------------------------------------------------------------|
| <p>1330 At the RAH-66 Aircraft 1 System Console (gt-1), enter < (less than sign) to display the vehicle's location. Record the values displayed.</p> <p>X <u>51000.59</u></p> <p>Y <u>5000.500</u></p> <p>Z <u>202.45</u></p> <p>UTM <u>ES960600</u></p> | <p>The X,Y,Z and UTM coordinates of the aircraft's location are displayed. The recorded values are approximately equivalent to: ES960600 => (51000, 5000)</p> <p>•3.2.1.1.2.9</p> | <p><input checked="" type="checkbox"/> S <input type="checkbox"/> SA <input type="checkbox"/> U</p> |
| <p>1340 At the RAH-66 1 Instrument display, verify that the lubber line is aligned with 270 degrees (West).</p> | <p>The lubber line is aligned with 270 degrees (West). The aircraft is positioned at its new location and heading.</p> <p>•3.2.1.1.2.9</p> | <p><input checked="" type="checkbox"/> S <input type="checkbox"/> SA <input type="checkbox"/> U</p> |
| <p>1350 Using the radio send a message ("MESSAGE FROM AIRCRAFT 1 to AIRCRAFT 2") to RAH-66 aircraft 2.</p> | <p>The message is transmitted to RAH-66 2 aircraft.</p> | <p><input checked="" type="checkbox"/> S <input type="checkbox"/> SA <input type="checkbox"/> U</p> |
| <p>1360 At the RAH-66 2 aircraft, use the radio to send a message ("MESSAGE FROM AIRCRAFT 2 to AIRCRAFT 1") to RAH-66 aircraft 1.</p> | <p>The message is received by RAH-66 1 aircraft.</p> | <p><input checked="" type="checkbox"/> S <input type="checkbox"/> SA <input type="checkbox"/> U</p> |
| <p>1370 Using the radio send a message ("MESSAGE FROM AIRCRAFT 1 to AIRCRAFT 3") to RAH-66 aircraft 3.</p> | <p>The message is transmitted to RAH-66 3 aircraft.</p> | <p><input checked="" type="checkbox"/> S <input type="checkbox"/> SA <input type="checkbox"/> U</p> |
| <p>1380 At the RAH-66 3 aircraft, use the radio to send a message ("MESSAGE FROM AIRCRAFT 3 to AIRCRAFT 1") to RAH-66 aircraft 1.</p> | <p>The message is received by RAH-66 1 aircraft.</p> | <p><input checked="" type="checkbox"/> S <input type="checkbox"/> SA <input type="checkbox"/> U</p> |

5.2.11 Modify the Communications Mode for Aircraft 1 and Crash the Vehicle - The steps in this subparagraph consist of instructions for modifying the communications mode to OVERRIDE ON and crashing the aircraft 1 vehicle.

<u>Step</u>	<u>Operator/System Action</u>	<u>Expected Result</u>	<u>Status</u> (Check One)
1390	At the RAH-66 Aircraft 1, set the radio communications switch to the state associated with OVERRIDE ON (Radios Always Enabled).	The radio is set to be always enabled.	<input checked="" type="checkbox"/> S <input type="checkbox"/> SA <input type="checkbox"/> U

- 1400 Take off and ascend to a height of 500 ft. above ground level. Point the nose of the aircraft towards the ground and descend until the vehicle crashes. The aircraft crashes into the ground. S SA U
- 1410 Using the radio send a message ("MESSAGE FROM AIRCRAFT 1 to AIRCRAFT 2") to RAH-66 aircraft 2. The message is transmitted to RAH-66 2 aircraft. *3.2.1.6.3.1 (one-way) S SA U
- 1420 At the RAH-66 2 aircraft, use the radio to send a message ("MESSAGE FROM AIRCRAFT 2 to AIRCRAFT 1") to RAH-66 aircraft 1. The message is received by RAH-66 1 aircraft. *3.2.1.6.3.1 (2-way) S SA U

5.2.12 Modify the Communications Mode for Aircraft 3 and Attempt Communications - The steps in this subparagraph consist of instructions for modifying the communications mode to OVERRIDE OFF and attempting communications with other vehicles.

<u>Step</u>	<u>Operator/System Action</u>	<u>Expected Result</u>	<u>Status</u> (Check One)
1430	At the RAH-66 Aircraft 3, set the radio communications switch to the state associated with OVERRIDE OFF (Radios Always Disabled).	The radio is set to be always disabled.	<input checked="" type="checkbox"/> S <input type="checkbox"/> SA <input type="checkbox"/> U
1440	Using the radio send a message ("MESSAGE FROM AIRCRAFT 3 to AIRCRAFT 2") to RAH-66 aircraft 2.	The message is NOT transmitted to RAH-66 2 aircraft.	<input checked="" type="checkbox"/> S <input type="checkbox"/> SA <input type="checkbox"/> U
1450	At the RAH-66 2 aircraft, use the radio to send a message ("MESSAGE FROM AIRCRAFT 2 to AIRCRAFT 3") to RAH-66 aircraft 3.	The message is NOT received by RAH-66 3 aircraft. *3.2.1.6.3.3	<input checked="" type="checkbox"/> S <input type="checkbox"/> SA <input type="checkbox"/> U
1460	At the RAH-66 Aircraft 3, use the radio to send a message ("MESSAGE FROM AIRCRAFT 3 to AIRCRAFT 1") to RAH-66 aircraft 1.	The message is NOT transmitted to RAH-66 1 aircraft.	<input checked="" type="checkbox"/> S <input type="checkbox"/> SA <input type="checkbox"/> U
1470	At the RAH-66 Aircraft 1, use the radio to send a message ("MESSAGE FROM AIRCRAFT 1 to AIRCRAFT 3") to RAH-66 aircraft 3.	The message is NOT received by RAH-66 3 aircraft. *3.2.1.6.3.3	<input checked="" type="checkbox"/> S <input type="checkbox"/> SA <input type="checkbox"/> U

5.2.13 Modify the Communications Mode for Aircraft 3 and Communicate - The steps in this subparagraph consist of instructions for modifying the communications mode to AUTO and communicating with other vehicles.

<u>Step</u>	<u>Operator/System Action</u>	<u>Expected Result</u>	<u>Status</u> (Check One)
1480	At the RAH-66 Aircraft 3, set the radio communications switch to the state associated with AUTO (Radios Software Controlled).	The radio is set to be software controlled.	<input checked="" type="checkbox"/> S <input type="checkbox"/> SA <input type="checkbox"/> U
1490	Using the radio send a message ("MESSAGE FROM AIRCRAFT 3 to AIRCRAFT 1") to RAH-66 aircraft 1.	The message is transmitted to RAH-66 1 aircraft.	<input checked="" type="checkbox"/> S <input type="checkbox"/> SA <input type="checkbox"/> U
1500	At the RAH-66 1 aircraft, use the radio to send a message ("MESSAGE FROM AIRCRAFT 1 to AIRCRAFT 3") to RAH-66 aircraft 3.	The message is received by RAH-66 3 aircraft. •3.2.1.6.3.2	<input checked="" type="checkbox"/> S <input type="checkbox"/> SA <input type="checkbox"/> U
1510	At the RAH-66 Aircraft 3, take off and ascend to a height of 500 ft. above ground level. Point the nose of the aircraft towards the ground and descend until the vehicle crashes.	The aircraft crashes into the ground. The communications are now disabled.	<input checked="" type="checkbox"/> S <input type="checkbox"/> SA <input type="checkbox"/> U
1520	Using the radio send a message ("MESSAGE FROM AIRCRAFT 3 to AIRCRAFT 1") to RAH-66 aircraft 1.	The message is NOT transmitted to RAH-66 1 aircraft.	<input checked="" type="checkbox"/> S <input type="checkbox"/> SA <input type="checkbox"/> U
1530	At the RAH-66 1 aircraft, use the radio to send a message ("MESSAGE FROM AIRCRAFT 1 to AIRCRAFT 3") to RAH-66 aircraft 3.	The message is NOT received by RAH-66 3 aircraft. •3.2.1.6.3.2	<input checked="" type="checkbox"/> S <input type="checkbox"/> SA <input type="checkbox"/> U

5.2.14 Terminate the Exercise - The steps in this subparagraph consist of instructions for terminating the exercise.

<u>Step</u>	<u>Operator/System Action</u>	<u>Expected Result</u>	<u>Status</u> (Check One)		
1540	At the AIRNET SCC, select the End Exercise option.	An End Exercise Confirmation Menu is displayed.	<input checked="" type="checkbox"/> S	<input type="checkbox"/> SA	<input type="checkbox"/> U
1550	Respond to the Confirmation Question by clicking on YES.	The Confirmation Display disappears and the display returns to the Macintosh windows screen. The CIG sound and visuals are terminated. •3.2.1.4 •3.2.1.4.1.5 •3.2.1.4.2 •3.2.1.4.3	<input checked="" type="checkbox"/> S	<input type="checkbox"/> SA	<input type="checkbox"/> U

6.0 NOTES

Test failures will be noted in the procedure against each test step as necessary where test results do not agree with expected results. Due to the nature of these system level tests, a simulator "crash" due to pilot error will not be constituted as a failure but an acceptable interruption. The system provides the capability for re-starting at the point of where the crash occurred and will be utilized during the execution of this system level test.

7.0 Test Failures/Interruptions

NOTE ANY FAILURES ENCOUNTERED DURING THE TEST IN THIS SECTION.

NO.	FAILURE/INTERRUPTION DESCRIPTION

8.0 Glossary

Admin./Log	Administration/Logistics
ADFS	Address
AIRNET	Aircraft Simulation Network
ALOC	Administration/Logistics Operations Console
Ammo	Ammunition
BBN	Bolt, Beranek, and Newman
CECI	Communications and Electronics Operations Instructions
CIG	Computer Image Generator
CPG	Co-Pilot/Gunner
DMCC	Digital Message Communications Console
DMS	Digital Message Server
ETA	Estimated Time of Arrival
FRED	Fully Reconfigurable Device
FREE TXT	Free Text
FSE	Fire Support Element
FWD	Forward
GT-111	BBN Computer System/CIG supporting Simulation
HEI	High Explosive Incendiary
HUMMV	High Mobility Multi-Wheeled Vehicle
I & T	Integration & Test
IMMED	Immediately
lbs.	pounds
LCTN	Location
Mac	Macintosh Computer
MCC	Management, Command and Control Console
MIPS	AIRNET MCC Host Computer
MOV TO	Move To
MOV CMD	Move Command
MSG	Message
MSGS	Messages
MTO	Movement to Order
PDU	Protocol Data Unit
PIE	Pyrotechnic Incendiary Explosive
RAH-66	Comanche Helicopter
RECON	Reconnaissance
RECON TYPE	Reconnaissance Type
REQT	Request
RPRT	Report
RWA	Rotary Wing Aircraft
S/W	Software
SOC	System Control Console
SOF	System Development Facility, Loral WDL, San Jose
SIMNET	Simulation Network
SND ROUT	Send Routine
SND URG	Send Urgent
SYS MAIN	System Main Menu
TOC	Tactical Operations Center
UMCP	Unit Maintenance Collection Point
UTM	Universal Transverse Mercator
WDL	Western Development Labs

WHN RDY
XMIT ALT
XMIT LCN

When Ready
Transmit Altitude
Transmit Location

APPENDIX A

EXERCISE "C" REQUIREMENTS MATRIX

REQ NO.	TITLE	REQUIREMENT
3.2.1.1.1.10	RAH-66 Configuration	The MCC shall allow the configuration of one to eight RAH-66 Comanche simulators engaged in simulated reconnaissance, tactical maneuver, or battle exercises.
3.2.1.1.1.12	Placement Conflict	The MCC shall place simulated vehicles in non-overlapping positions and reposition vehicles that are located in overlapping positions.
3.2.1.1.1.13	Minimum Placement Distance	The MCC shall resolve the placement such that the simulators are at least 33 meters apart.
3.2.1.1.2.9	Placement After Reconstitution	The MCC shall inform the RAH-66 Comanche simulator about its new location and heading (placement) during reconstitution of the vehicle.
3.2.1.2.2.2.1	PreFormatted Text Messages	The TOC or FSE shall be capable of sending preformatted messages to the RAH-66 Comanche player(s). A preformatted message is any previously defined message file.
3.2.1.2.2.2.2	Free Text Messages	The TOC or FSE shall be capable of sending free text messages to the RAH-66 Comanche player(s). A free text message is any message entered by the station operator within the Access Mode.
3.2.1.4	Improved Collective Mount	The delivered hardware shall insure that existing software is compatible.
3.2.1.4.1.5	Compatibility	The Improved Collective Mount shall be compatible with existing generic RWA software.
3.2.1.4.2	Segment Capability Relationships	Improved Collective Mount capability relationships are not affected by modifications and restructuring of the flight model functions. The capability relationships have remained intact.
3.2.1.4.3	Segment External Interface Requirements	Improved Collective Mount interface requirements are not affected by modifications and restructuring of the flight model functions.
3.2.1.6.1	Initialization State	The Kill COMM Initialization state places the communications system into a known state. The Initialization state has no modes.
3.2.1.6.1.1	COMM On Variable	The Kill COMM Initialization shall set the communications "COMM On" variable to enable ownship two-way communications.
3.2.1.6.2.1	Run Time COMM On Mode	The Run Time COMM On mode shall enable two-way communications between the ownship and other AirNet vehicles.

REQ NO.	TITLE	REQUIREMENT
3.2.1.6.2.2	Run Time COMM Off Mode	The Run Time COMM Off mode shall disable two-way communications between the ownship and other AirNet vehicles.
3.2.1.6.3.1	Over-ride_On Mode	The "over-ride_on" mode shall disable S/W control to the communications system and enable two-way communications.
3.2.1.6.3.2	Auto Mode	The "auto" mode shall enable S/W control of the communication system.
3.2.1.6.3.3	Over-ride_Off Mode	The "over-ride_off" mode shall disable S/W control of the communications system and disable communications to other AirNet devices.

**ATAC II
Requirements**

3.3.1.8	Manned Rotary Wing Aircraft	The Situation Awareness Display (SAD) menu shall be modified to allow modification of eight Laser Codes A - H.
3.3.1.9	Manned Rotary Wing Aircraft	The SAD keypad shall allow the user to toggle through the valid laser codes plus the "normal" rangefinder mode for use by the laser range finder/designator.
3.3.1.13 See Note (1)	Manned Rotary Wing Aircraft	The Hellfire impact point shall be determined by the laser designation point, whether local (autonomous fire) or remote.
3.3.1.16.1	Manned Rotary Wing Aircraft	The SAD menu and keypad shall allow the user to select laser code A - H for use as the primary code by the Hellfire missile.
3.3.1.16.2	Manned Rotary Wing Aircraft	The SAD menu and keypad shall allow the user to select laser code A - H for use as the secondary code by the Hellfire missile.
3.3.1.16.3	Manned Rotary Wing Aircraft	The SAD menu and keypad shall allow the user to toggle between primary and secondary laser codes.
3.3.1.20	Manned Rotary Wing Aircraft	The laser designator mode symbology, consisting of the laser code A - H plus the four digit data field shall be displayed for 10 seconds, after which time only the laser code A - H will remain displayed.
3.3.1.22	Manned Rotary Wing Aircraft	The Hellfire laser code A - H shall be displayed near the bottom of the sensor display, in the same row and to the left of the TOF symbology.
3.3.1.30.1	Manned Rotary Wing Aircraft	The following shall be modifiable at any time the RWA is in an active state of simulation: Laser code data for laser codes A - H.
3.3.1.30.3	Manned Rotary Wing Aircraft	The following shall be modifiable at any time the RWA is in an active state of simulation: Laser code to be used by the Hellfire missile
3.3.1.30.4	Manned Rotary Wing Aircraft	The following shall be modifiable at any time the RWA is in an active state of simulation: Laser code or "normal" rangefinder mode to be used by the laser rangefinder/designator.

Notes:

(1) This requirement is satisfied for remote fire only. The procedures verifying this requirement for local (autonomous fire) may be found in Exercise "A".

Appendix B

Exercise "C" Requirements Inspection/Analysis Matrix

REQ NO.	TITLE	REQUIREMENT	Report Reference
3.2.1.4.1.1	Smoother Operation	The collective shall rotate smoothly around its pivot axis for all values of angular velocity anticipated in normal operations for the entire 45° range of travel.	1
3.2.1.4.1.2	Friction Mechanism	The friction mechanism shall maintain its setting within 10% of initial pilot adjustment throughout the entire sortie (provided no readjustment is made).	1
3.2.1.4.1.3	Continuous Range Adjustment	The collective friction shall be continuously adjustable to provide a range of 12 to 420 in-lbs of resistive force in both directions of rotation throughout the entire range of travel.	1
3.2.1.4.1.4	Position Sensing Mechanism	The collective sensing mechanism shall increase the travel of the position sensing potentiometer by 30%.	1
3.9.4	Improved Collective Mount Segment Qualification	The Improved Collective Mount Segment shall be qualification tested at Ft. Rucker.	2
3.9.4.a	Improved Collective Mount Segment Qualification	The Improved Collective Mount Segment test shall take place during the program integration and test phase (I&T).	2
3.9.4.b	Improved Collective Mount Segment Qualification	The Improved Collective Mount Segment test shall not exceed 1 working day.	2
3.9.4.c	Improved Collective Mount Segment Qualification	The testing shall demonstrate the Improved Collective Mount Segment provides the functionality described previously in this document.	2
3.9.6	Kill Communications Upgrade Segment Qualification	The Kill Communications Upgrade Segment shall be qualification tested at Ft. Rucker.	2

REQ NO.	TITLE	REQUIREMENT	Report Reference
3.9.6.a	Kill Communications Upgrade Segment Qualification	The Kill Communications Upgrade Segment test shall take place during the program integration and test phase (I&T).	2
3.9.6.b	Kill Communications Upgrade Segment Qualification	The Kill Communications Upgrade Segment test shall not exceed 1 working 1 day.	2
3.9.6.c	Kill Communications Upgrade Segment Qualification	The testing shall demonstrate the Kill Communications Upgrade Segment provides the functionality described previously in this document.	2

**ATAC II
Requirements**

3.3.1.1	Manned Rotary Wing Aircraft	The RWA shall be able to check for the existence of the Missile Server on the simulation network.	3
3.3.1.2	Manned Rotary Wing Aircraft	The RWA shall listen for an acknowledgement from the Missile Server.	3
3.3.1.3	Manned Rotary Wing Aircraft	The RWA shall be able to handoff simulation of the Hellfire missile to the Missile Server.	3
3.3.1.4	Manned Rotary Wing Aircraft	The RWA shall be able to cancel handoff of the Hellfire missile to the Missile Server.	3
3.3.1.6	Manned Rotary Wing Aircraft	A Missile Server must be present in order for remote Hellfire designation functionality to exist.	3
3.3.1.7	Manned Rotary Wing Aircraft	Laser Code Data shall be in the form of a four digit number with digits consisting solely of the numbers 1 thru 8.	4
3.3.1.23	Manned Rotary Wing Aircraft	When laser designating, the RWA shall transmit PDUs onto the simulation network describing the location being designated.	3
3.3.1.24	Manned Rotary Wing Aircraft	When laser designating has stopped, the RWA shall transmit a PDU onto the simulation network signifying this event.	3
3.3.1.28	Manned Rotary Wing Aircraft	The SAD shall allow laser code data for laser codes A - H to be saved to disk.	5

REQ NO.	TITLE	REQUIREMENT	Report Reference
3.3.1.29	Manned Rotary Wing Aircraft	The SAD shall allow laser code data for laser codes A - H to be retrieved from disk.	5

Appendix C

Exercise "C" Inspection/Analysis Reports

Report Reference

1. Collective Mount Requirements
2. Collective Mount and Kill Communications Qualification Requirements
3. Missile Server Requirements
4. Laser Code Requirement
5. Laser Code Data File Requirements

AIRNET INSPECTION/ANALYSIS REPORT 1

Req. No.: 3.2.1.4.1.1	Spec. Para.: 3.2.1.4.1.1
3.2.1.4.1.2	3.2.1.4.1.2
3.2.1.4.1.3	3.2.1.4.1.3
3.2.1.4.1.4	3.2.1.4.1.4

Requirement Descriptions

Req. No.: 3.2.1.4.1.1 Smoother Operation

The collective shall rotate smoothly around its pivot axis for all values of angular velocity anticipated in normal operations for the entire 45° range of travel.

Req. No.: 3.2.1.4.1.2 Friction Mechanism

The friction mechanism shall maintain its setting within 10% of initial pilot adjustment throughout the entire sortie (provided no readjustment is made).

Req. No.: 3.2.1.4.1.3 Continuous Range Adjustment

The collective friction shall be continuously adjustable to provide a range of 12 to 420 in-lbs of resistive force in both directions of rotation throughout the entire range of travel.

Req. No.: 3.2.1.4.1.4 Position Sensing Mechanism

The collective sensing mechanism shall increase the travel of the position sensing potentiometer by 30%.

Inspection Method: The collective mount hardware has been installed at Ft. Rucker and is in current operation. This hardware can be inspected to verify compliance with the requirements listed above.

VERIFIED: _____

TITLE: _____

CONCURRENCE: _____

AIRNET INSPECTION/ANALYSIS REPORT 2

Reqt. No.:	3.9.4	Spec. Para.:	3.9.4
	3.9.4.a		3.9.4
	3.9.4.b		3.9.4
	3.9.4.c		3.9.4
	3.9.6		3.9.6
	3.9.6.a		3.9.6
	3.9.6.b		3.9.6
	3.9.6.c		3.9.6

Requirement Descriptions

Reqt. No.: 3.9.4 Improved Collective Mount Segment Qualification
The Improved Collective Mount Segment shall be qualification tested at Ft. Rucker.

Reqt. No.: 3.9.4.a Improved Collective Mount Segment Qualification
The Improved Collective Mount Segment test shall take place during the program integration and test phase (I&T).

Reqt. No.: 3.9.4.b Improved Collective Mount Segment Qualification
The Improved Collective Mount Segment test shall not exceed 1 working day.

Reqt. No.: 3.9.4.c Improved Collective Mount Segment Qualification
The testing shall demonstrate the Improved Collective Mount Segment provides the functionality described previously in this document.

Reqt. No.: 3.9.6 Kill Communications Upgrade Segment Qualification
The Kill Communications Upgrade Segment shall be qualification tested at Ft. Rucker.

Reqt. No.: 3.9.6.a Kill Communications Upgrade Segment Qualification
The Kill Communications Upgrade Segment test shall take place during the program integration and test phase (I&T).

Reqt. No.: 3.9.6.b Kill Communications Upgrade Segment Qualification
The Kill Communications Upgrade Segment test shall not exceed 1 working day.

Reqt. No.: 3.9.6.c Kill Communications Upgrade Segment Qualification
The testing shall demonstrate the Kill Communications Upgrade Segment provides the functionality described previously in this document.

Inspection Method: The test procedures for Scenario C can be inspected to verify compliance with the requirements listed above.

VERIFIED: _____

TITLE: _____

CONCURRENCE: _____

AIRNET INSPECTION/ANALYSIS REPORT 3

Req. No.:	ATAC II 3.3.1.1	Spec. Para.:	3.3.1
	ATAC II 3.3.1.2		3.3.1
	ATAC II 3.3.1.3		3.3.1
	ATAC II 3.3.1.4		3.3.1
	ATAC II 3.3.1.6		3.3.1
	ATAC II 3.3.1.23		3.3.1
	ATAC II 3.3.1.24		3.3.1

Requirement Descriptions:

Req. No.: 3.3.1.1 Manned Rotary Wing Aircraft
The RWA shall be able to check for the existence of the Missile Server on the simulation network.

Req. No.: 3.3.1.2 Manned Rotary Wing Aircraft
The RWA shall listen for an acknowledgement from the Missile Server.

Req. No.: 3.3.1.3 Manned Rotary Wing Aircraft
The RWA shall be able to handoff simulation of the Hellfire missile to the Missile Server.

Req. No.: 3.3.1.4 Manned Rotary Wing Aircraft
The RWA shall be able to cancel handoff of the Hellfire missile to the Missile Server.

Req. No.: 3.3.1.6 Manned Rotary Wing Aircraft
A Missile Server must be present in order for remote Hellfire designation functionality to exist.

Req. No.: 3.3.1.23 Manned Rotary Wing Aircraft
When laser designating, the RWA shall transmit PDUs onto the simulation network describing the location being designated.

Req. No.: 3.3.1.24 Manned Rotary Wing Aircraft
When laser designating has stopped, the RWA shall transmit a PDU onto the simulation network signifying this event.

Inspection Method: Function `veh_spec_init` is called when the simulation state is `SIM_SIMINIT_STATE`. Among other things, this function makes a call to function `rwa_desig_init` to perform the initialization for remote laser designation processing. `rwa_desig_init` makes a call to `remdesig` who in turn calls `remdesig_send_server_identify`. This function checks for the existence of a Missile Server on the simulation network by sending a request for servers to identify themselves (Req. 3.3.1.1). Servers acknowledge their presence on the network via a `DesigServerEntityVariant` (Req. 3.3.1.2). Receipt of this data causes the server state to transition allowing missile handoff. If no `DesigServerEntityVariant` is received `remdesig_send_server_identify` is again called; remote designation is allowed only if a missile server can be identified (Req. 3.3.1.6).

Once a missile server has been identified, missile simulation can be handed off. This functionality is accomplished by function `remdesig_handoff` which calls function `remdesig_send_handoff` which transmits the `DesignatorHandoffVariant` over the simulation network (Req. 3.3.1.4). Missile handoff is canceled through function `remdesig_cancel_handoff`. This function calls function `remdesig_send_cancel_handoff` which transmits a `DesignatorCancelHandoffVariant` over the simulation network (Req. 3.3.1.4).

Function `remdesig_designate` uses function `remdesig_send_designate` to transmit `DesignatorDesignateVariants` over the simulation network describing the location being designated (Req. 3.3.1.23). Likewise, `remdesig_stop_designate` uses function `remdesig_send_stop_designate` to transmit `DesignatorStopDesignateVariants` over the simulation network identifying when laser designating has stopped (Req. 3.3.1.24).

These functions can be inspected for compliance with the above listed requirements.

VERIFIED: _____

TITLE: _____

CONCURRENCE: _____

AIRNET INSPECTION/ANALYSIS REPORT 4

Req. No.: ATAC II 3.3.1.7

Spec. Para.: 3.3.1

Requirement Descriptions:

Req. No.: 3.3.1.7 Manned Rotary Wing Aircraft

Laser Code Data shall be in the form of a four digit number with digits consisting solely of the numbers 1 thru 8.

Inspection Method: Function `convert_data` converts a laser code character data string, as input from the user, to an integer value. This function first checks the length of the string, returning a null value if the string is not equal to four digits. It then checks each digit within the string to see if it is in the range $1 \leq \text{digit} \leq 8$. If an invalid digit is found, a null value is returned, otherwise the integer version of the value is returned. Function `convert_data` can be inspected for compliance with requirement 3.3.1.7.

VERIFIED: _____

TITLE: _____

CONCURRENCE: _____

AIRNET INSPECTION/ANALYSIS REPORT 5

Req. No.: ATAC II 3.3.1.28
Req. No.: ATAC II 3.3.1.29

Spec. Para.: 3.3.1
Spec. Para.: 3.3.1

Requirement Descriptions:

Req. No.: 3.3.1.28 Manned Rotary Wing Aircraft
The SAD shall allow laser code data for laser codes A - H to be saved to disk.

Req. No.: 3.3.1.29 Manned Rotary Wing Aircraft
The SAD shall allow laser code data for laser codes A - H to be retrieved from disk.

Inspection Method: As implemented in the original ATAC II upgrade and the AIRNET upgrade to the ATAC II software, laser code data can be saved/retrieved via commands entered at the GT-111 System Console. Capabilities to save/retrieve laser code data via the Situation Awareness Display (SAD) were not available in the original implementation, nor are they available in the AIRNET upgrade version. The "Better" command line editor allows laser code data to be saved and retrieved. This editor is entered by entering a "B" at the command line of the standard RWA command line editor. Commands to save and retrieve laser code data are: "set laser save" and "set laser retrieve". The laser codes may be viewed on both the SAD and System Console (command: show laser). The software can be inspected to verify that the AIRNET upgrades maintain the functionality available in the original ATAC II executable.

VERIFIED: _____

TITLE: _____

CONCURRENCE: _____