

AD-A280 891



WL-TR-93-8034

**DEVELOPMENT OF A SPINDLE
THERMAL ERROR CHARACTERIZATION
AND COMPENSATION SENSOR SYSTEM
FOR MACHINING CENTER
ACCURACY ENHANCEMENT**



Dr. K.C. Lau

**Automated Precision, Inc.
7901-C Cessna Avenue
Gaithersburg, MD 20879**

**DTIC
ELECTE
JUN 3 0 1994
S F D**

DECEMBER 1993

Final Technical Report

DTIC QUALITY INSPECTED 2

For Period April 1991 to March 1993

Approved for public release; distribution is unlimited

**MANUFACTURING TECHNOLOGY DIRECTORATE
WRIGHT LABORATORY
AIR FORCE MATERIEL COMMAND
WRIGHT-PATTERSON AFB, OHIO 45433-7739**

94-19955



94 6 29 027

NOTICE

When Government drawings, specifications or other data are used for any purpose other than in connection with a definitely related Government procurement operation, the United States Government thereby incurs no responsibility nor any obligation whatsoever; and the fact that the Government may have formulated, furnished, or in any way supplied the said drawings, specifications, or other data, is not to be regarded by implication or otherwise as in any manner licensing the holder or any other person or corporation, or conveying any rights or permission to manufacture, use, or sell any patented invention that may in any way be related thereto.

This report has been reviewed by the Office of Public Affairs (ASD/PA) and is releasable to the National Technical Information Service (NTIS). At NTIS, it will be available to the general public, including foreign nations.

This technical report has been reviewed and is approved for publication.



KEVIN R. SPITZER
Project Engineer



STEPHEN D. THOMPSON
Supervisor

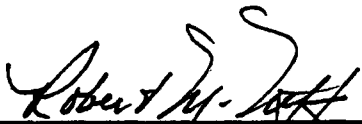

ROBERT M. NEFF, Chief
Process & Fabrication Division
Manufacturing Technology Directorate
Technology Directorate

If your address has changed, if you wish to be removed from our mailing list, or if the addressee is no longer employed by your organization please notify WL/MTPM Building 653, 2977 P Street Suite 6, Wright-Patterson AFB OH 45433-7739 to help maintain a current mailing list.

Copies of this report should not be returned unless return is required by security considerations, contractual obligations, or notice on a specific document.

REPORT DOCUMENTATION PAGE

FORM APPROVED
OMB NO. 0704-0188

Public reporting burden for this collection of information is estimated to average 1 hour per response, including the time for reviewing instructions, searching existing data sources, gathering and maintaining the data needed, and completing and reviewing the collection of information. Send comments regarding this burden estimate or any other aspect of this collection of information, including suggestions for reducing this burden, to Washington Headquarters Services, Directorate for Information Operations and Reports, 1215 Jefferson Davis Highway, Suite 1204, Arlington, VA 22202-4302, and to the Office of Management and Budget, Paperwork Reduction Project (0704-0188), Washington, DC 20503.

1. AGENCY USE ONLY (Leave Blank)		2. REPORT DATE December 1993	3. REPORT TYPE AND DATES COVERED Final April 1991 - March 1993
4. TITLE AND SUBTITLE Development of a Spindle Thermal Error Characterization and Compensation Sensor System for Machining Center Accuracy Enhancement		5. FUNDING NUMBERS C F33615-91-C-5709 PE 78011 PR 3095 TA 06 WU 61	
6. AUTHOR(S) Dr. K.C. Lau		8. PERFORMING ORGANIZATION REPORT NUMBER	
7. PERFORMING ORGANIZATION NAME(S) AND ADDRESS(ES) Automated Precision, Inc. 7901-C Cessna Ave. Gaithersburg, MD 20879		10. SPONSORING/MONITORING AGENCY REP NUMBER WL-TR-93-8034	
9. SPONSORING MONITORING AGENCY NAME(S) AND ADDRESS(ES) Kevin Spitzer, WL/MTPM, 513/255-2413 Manufacturing Technology Directorate Wright Laboratory • AFMC Wright-Patterson AFB, OH 45433-7739		11. SUPPLEMENTARY NOTES	
12a. DISTRIBUTION/AVAILABILITY STATEMENT Approved for public release; distribution is unlimited.		12b. DISTRIBUTION CODE	
13. ABSTRACT Automated Precision Incorporated under contract with Wright Laboratory's Manufacturing Technology Directorate has developed a low cost, real-time, sensor/computer based, high performance spindle thermal modeling and compensation system for production computer numeric control (CNC) machining centers. This sensor based system is designed to measure spindle thermal error which, when corrected, improves precision machining accuracy.			
14. SUBJECT TERMS Machine Tools, Sensors.		15. NUMBER OF PAGES 42	
		16. PRICE CODE	
17. SECURITY CLASSIFICATION OF REPORT Unclassified	18. SECURITY CLASS OF THIS PAGE Unclassified	19. SECURITY CLASS OF ABSTRACT Unclassified	20. LIMITATION ABSTRACT UL

Standard Form 298 (Rev 2-89)
Prescribed by ANSI Std Z39-18
298-102

TABLE OF CONTENTS

	Page
List of Figures	iv
1. Introduction	1
2. Prior Work	3
3. Technical Objective	5
4. Sensor System Development	5
4.1 Proximity Sensor Development	5
4.2 Thermal Sensor Development	9
4.3 Sensor Interface Controller Development	12
4.4 User-friendly Software Development	12
5. Thermal Modeling and the Computer Aided Sensor Correlation System (CACS)	16
5.1 Analytical Vs. Parametric Thermal Modeling Approach	16
5.2 Spindle Thermal Growth Measurement	17
5.3 Thermal Modeling	19
5.4 Principle of Sensor Correlation	22
6. Testing and Evaluation of the Spindle Thermal Modeling System	27
7. Conclusions and Discussions	33
8. References	36

Accession For	
NTIS CRA&I	<input checked="" type="checkbox"/>
DTIC TAB	<input type="checkbox"/>
Unannounced	<input type="checkbox"/>
Justification	
By	
Distribution /	
Availability Codes	
Dist	Avail and/or Special
A-1	

LIST OF FIGURES

Title	Page
1. Six Degrees of Freedom for X-axis	6
2. Systematic Structure of the Sensor System	6
3. Output of an Optical Sensor (HPCS-1100)	8
4. Optical Sensor Test Setup on a Lathe	8
5. Schematic Diagram of an API Capacitance Gauge	10
6. Block Diagram of a Capacitance Gauge Circuit	10
7. Thermal Drift Test Results of an API Capacitance Gauge	11
8. Capacitance Sensor Setup with Mounting Fixture	11
9. IC Thermal Sensor with Magnet Base	13
10. Schematic Diagram of Electronics Controller	14
11. Block Diagram of Software Structure	15
12. Capacitance Sensor Setup Screen	15
13. Effect of Spindle Speed Variation	18
14. Effect of Temperature History	18
15. Effect of Environmental Temperature Variation	20
16. Concept of Correlation Coefficient	23
17. CASC System Graphics Display	24
18. Thermal Sensor Setup on a Monarch Machining Center	26
19. Effect of Improved Model	29
20. Thermal Growth Prediction in Z-axis (3000 rpm)	29

Title	Page
21. Thermal Growth Prediction in Z-axis (6000 rpm)	30
22. Thermal Growth Prediction in Z-axis (6000 rpm)	30
23. Thermal Growth Prediction in z-axis (7000 rpm)	31
24. Thermal Growth Prediction in Z-axis (9000 rpm)	31
25. Thermal Growth Modeling in Z-axis	32
26. Thermal Growth Prediction in Z-axis (random speed)	32
27. Thermal Growth in Z-axis at Two Different Locations	34
28. Thermal Test Result with Slide Movement	34

WL-TR-93-8034

**DEVELOPMENT OF A
SPINDLE THERMAL ERROR
CHARACTERIZATION AND COMPENSATION SENSOR SYSTEM
FOR
MACHINING CENTER ACCURACY ENHANCEMENT**

by

**Dr. Kam C. Lau, President
Automated Precision, Inc.
7901-C Cessna Avenue
Gaithersburg, MD 20879**

December 1993

FINAL TECHNICAL REPORT

1. INTRODUCTION

Thermally-induced error, as the term is applied to machine tools, is that error induced in the cutting or forming process as a result of temperature changes to and the resulting growth in the structure of the machine. The heat dissipated from motors and bearings and other heat generating components is almost always unevenly distributed within the machine structure. This causes structural deformation that is referred to as thermal growth. Thermal growth is often the major cause of machining errors in computer numerically controlled (CNC) machining centers. In some cases, thermal growth can contribute up to 70% of the total machining error.

As the demand has increased in recent years for better quality control and tighter manufacturing tolerances, more research efforts have been directed to the understanding and control of the thermal growth of CNC machining centers. Although various techniques for monitoring, characterizing and controlling spindle thermal growth have

been developed and demonstrated in a number of universities and research institutes, the bulk of the work is still too costly and cumbersome to be practical in a production environment.

Several problems are common for engineers and researchers working with thermal growth control: (1) a lack of standard equipment to perform quality measurements on machines, (2) a lack of standard user-friendly software and analysis tools for machine characterization, (3) too much time required in the characterization and modeling process, and (4) the model is generally inadequate for dealing with the situations encountered in actual production processes and environments.

In June 1991, Automated Precision, Inc. (API) obtained a research and development contract from the U.S. Air Force, Wright Laboratory, Manufacturing Technology Directorate to develop a commercially viable, robust, and user-friendly spindle thermal growth characterization and compensation system for production use on CNC machining centers. Acting as a collaborator and potential end-user of the system, Monarch Machine Company in Cortland, New York joined the program by providing test facilities, CNC machining centers and engineering time. The entire program consisted of the following major tasks:

- (1) development of a low-cost, high-performance, non-contact, proximity sensor subsystem for monitoring the thermally induced growth of the spindle of a machining center in the X-, Y- and Z-axis directions, plus the thermally induced pitch and yaw of the spindle,
- (2) development of a thermal couple array subsystem to monitor and correlate the thermal map of the machining center to the spindle growth,
- (3) development of a personal computer-based, user-friendly data acquisition and thermal modeling system to characterize the thermal growth behavior of the machining center and
- (4) testing and demonstration of the system in different production environments.

As a result of this program, an advanced, low-cost, spindle thermal growth modeling prototype system was developed. The system includes:

- (1) a 5-axis capacitance sensing and an integrated circuit-based thermal sensing subsystem to monitor the spindle thermal growth,
- (2) an IBM-PC-based, 14-bit, 64-channel, real-time data acquisition subsystem, and
- (3) a computer-aided sensor correlation (CASC) software system for sensor optimization, and modeling.

The system was fully tested and demonstrated at a number of locations which included the National Institute of Standards and Technology (NIST), Pratt & Whitney, University of North Carolina, Olofsson Corporation, Ford Motor Company and The Monarch Machine Tool Company.

Tests indicated that the system hardware was very reliable and very easy to use. The modeling process generally took less than three days and the modeling accuracy was about 80%. This required time was only about one-twentieth of the time taken for most modeling efforts, even when undertaken in a research environment.

These encouraging test results eventually led to the development and introduction of a new product - the THERMAC (Spindle Thermal Modeling and Compensation System) by API. Details of the system and the modeling process are described in later sections of this report.

2. PRIOR WORK

It is generally agreed that the thermal expansion of a machine-tool will dramatically affect the machining accuracy. After conducting an extensive study, Peklenik [1] remarked that thermal errors could contribute as much as 70% of the machining error. Therefore, among all the major machining error sources, the thermally induced error is considered to be the major problem. There are two methods that are commonly used in reducing the thermally induced errors on machine tools: error avoidance and error compensation.

Error avoidance techniques are often implemented at the machine-design stage. These include designs to minimize the effects of heat generation within the machine structure and control the gradient of and change in environmentally encountered temperatures. J.B. Bryan [2] of Lawrence Livermore Laboratory was successful in achieving thermal stability by immersing the whole machine in a temperature-controlled "oil bath." However, this method is very expensive and impractical for production machines. A less expensive and more practical method implemented by some machine-tool builders on more expensive machines makes use of a temperature-controlled oil shower applied around the spindle area where the major thermal growth is typically found. In general, this method can help reduce the thermal growth error by as much as 50%. Of course the cost of the machine is increased.

Error compensation techniques are based on a knowledge of the thermal growth characteristics of the machine and use this "thermal model" in real-time to predict the thermal growth. A digital processor utilizes this model to calculate the error information which is then sent to the machine's CNC controller to compensate for the sensed error. This error information is often in the form of tool offset commands.

By using multiple thermal sensors to measure the temperatures of the major heat sources, and five proximity sensors to measure the spindle thermal growth (in the X-, Y- and Z-axis directions, and in pitch and yaw), a computer-controlled modeling system will collect and store the data while the machine spindle is running. After enough data is collected, the system will establish a thermal model by analyzing the correlation between the temperatures and the thermal growth of each axis of the machine. As soon as the

performance of the model is verified, the model can be used in real-time to predict the thermal growths of the machine by using only the temperature information.

The error compensation technique has raised a lot of interest among machine tool manufacturers and users. It has the advantages of being low cost, easy to implement and can be readily retrofitted to existing machines without major design modifications. Real-time thermal growth compensation can be implemented using today's high speed desk top personal computers or, alternatively, by using a specially designed single board computer.

Recent research on thermal error compensation conducted by F. Rudder and A. Donmez [3] of NIST involved the establishment of a real-time geometric/thermal (G-T) model to characterize the thermal behavior of a vertical spindle machining center and a turning center. The geometric error data at various thermal states of the machine conditions were acquired and used to build the G-T model. J.S. Chen and J. Ni [4] of the University of Michigan (UM) have recently developed a time-variant volumetric error model which synthesizes both the geometric and thermal errors of a machining center.

In the case of the UM research, a 21 parameter kinematic model was used to establish the geometric model of the machine. An 11 parameter thermal growth model was used to establish the spindle growth parallel to the primary axes of the machine. All together, a 32 parameter G-T model was established. In both cases, tests were conducted in a laboratory environment under dry, no load conditions. A laser interferometer system was used for the 21 geometric parameter measurements, and a combination of laser and capacitance measurements were used for the 11 parameter thermal growth measurements. The models took 2 to 6 months to establish, far too long to be practical. The accuracy improvement was about 90% for simple warm-up and cool-down cycles of the machine.

The strategy adopted by API is somewhat different from that taken by NIST, UM and others. Instead of establishing a G-T model, the API technique simplifies the entire process by focusing on the thermal model alone. A new model was developed which utilizes differential temperature data as input parameters. This model has proven to be very effective in handling actual production situations involving such things as short duration speed changes, spindle stops, ramps up and down, etc., as well as the long-term warm-up and cool-down cycles. By focusing on the thermal model alone, the entire testing and modeling processes are drastically reduced and the accuracy enhanced.

To establish the geometric model, some well-known techniques and measuring systems like the API WINNER 2.0 system can be used. Compared to the independent laser interferometer measurements that were used at NIST and UM, WINNER utilizes alternative measuring devices such as a telescopic ballbar, electronic autocollimator, electronic level and others to measure the geometric errors of the machine. In cases like squareness, straightness and flatness measurements, these alternative devices are much better suited for the job than the laser interferometer. They are less costly, much easier to setup and sometimes more versatile than a laser interferometer system. Consequently, the combination of simplified but advanced modeling procedures, and a better choice of

measuring instruments has allowed the API technique to shorten the actual modeling process from months to a matter of a few days.

3. TECHNICAL OBJECTIVE

The program objective was to develop an advanced, commercial, easy-to-use, inexpensive spindle error characterization and compensation system for production CNC machining centers.

To achieve this objective, it is useful to first consider the spindle of a machine tool to be a rigid body. Then the spindle's total motion in a three-dimensional machine work zone can be represented using 6 degrees-of-freedom, i.e., three translation motions along the X, Y and Z axes of the machine slides, plus pitch, yaw, and roll motions around these three orthogonal axes. See Figure 1. Since roll is the turning axis of the spindle, it is not a measuring parameter.

In order to accomplish the program objective, the following major tasks were pursued:

- (1) development of a low-cost, high-performance, non-contact, proximity sensor subsystem for monitoring the X-, Y- and Z-axis thermal growth of the spindle of a machining center, plus the associated pitch and yaw growth,
- (2) development of a thermocouple array subsystem to monitor and correlate the thermal map of the machining center to the spindle growth,
- (3) development of a PC-based, user-friendly data acquisition and thermal modeling system to characterize the thermal growth behavior of the machining center,
- (4) testing, demonstration and evaluation of the system on CNC machining centers in a production environment.

Figure 2 illustrates the link between the hardware and software of the prototype system.

4. SENSOR SYSTEM DEVELOPMENT

4.1. Proximity Sensor Selection & Development

Proximity Sensor Requirements

Optical and capacitance sensors are the two most commonly used sensors for high-precision non-contact measurement in industry. In the early stage of development, efforts were directed toward the testing of various proximity sensors for that application. Key factors that needed to be considered were:

- (a) Measuring range - Typical spindle drift is between ± 0.003 " and ± 0.010 ". Therefore a measuring range of at least ± 0.015 " was required.

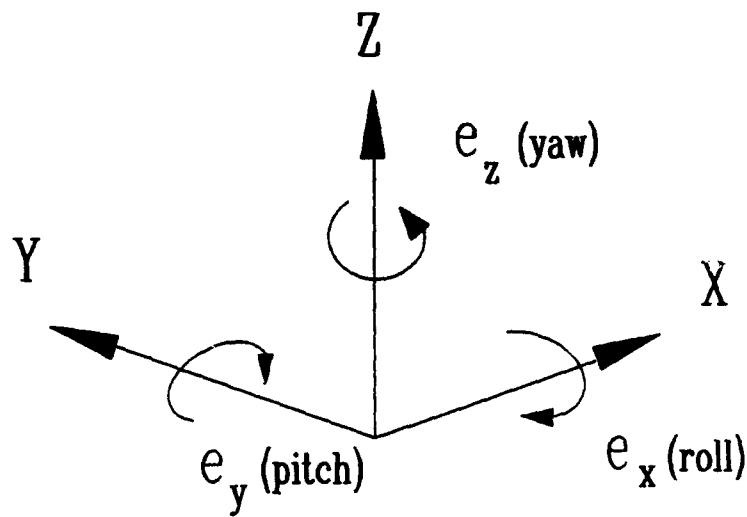

Figure 1. Six Degrees of Freedom for X-axis

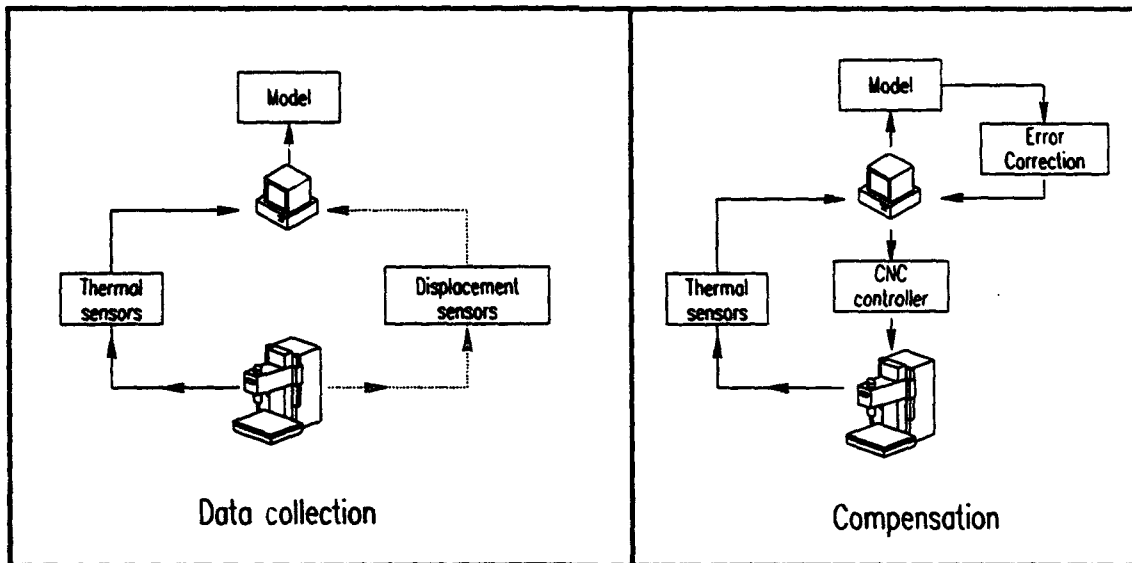

Figure 2. Systematic Structure of the Sensor System

- (b) **Sensitivity** - Sensitivity of the sensor should be 0.000040" (1 μ m) or better. This can cover a wide range of machine accuracy requirements and machine types, and
- (c) **Robustness** - Sensor should be factory hardened and robust enough for production applications.

Optical Displacement Sensors:

The first non-contact sensor tested was an optical sensor. The sensor was constructed based on a Hewlett-Packard HBCS-1100 optical device. Its measuring principle was based on an image focusing and defocusing effect. See the performance characteristic shown in Figure 3. By limiting the measuring range on either side of the focus point of the sensor, absolute displacement measurements could be made with reasonable accuracy.

Based on the tests, the following were the characteristics of the optical sensor:

range:	2 mm
sensitivity:	1 μ m per millivolt
voltage output:	10 volt dc
short-term stability:	better than 1 millivolt

The advantages of the optical sensor were that it was easy to use, it was inexpensive and it was based on a compact design. The major disadvantage for this application was that the sensitivity of the sensor changed significantly with different surface conditions and incident angles. Conditions such as different surface finishes, surface contamination, and surface angle compared to normal could alter the sensor calibration very easily.

Two optical sensors were initially tested on a lathe at API. See Figure 4 for setup. The sensors were mounted on an aluminum rectangular fixture facing to a measuring bar. Results indicated that while the optical sensors did provide enough sensitivity and range for the spindle thermal error measurement, their output signals were greatly affected by the surface conditions, such as contamination, of the measuring bar. By contaminating the bar surface with a light film of lubricating oil, the sensitivity of the sensor dropped by as much as 40%. This indicated that optical sensors were undesirable for use in a production environment.

Capacitance Proximity Sensors:

Capacitance sensors are very precise, non-contact devices but are often very delicate. Most commercial capacitance sensors are not suitable for spindle thermal drift measurement because of :

- (1) not having enough measuring range (typically below 0.004")
- (2) having significant thermal drift characteristics (most capacitance sensors drift by as much as 40 μ inches per $^{\circ}$ C), and
- (3) being too costly for the application (approximately \$5,000 per sensor).

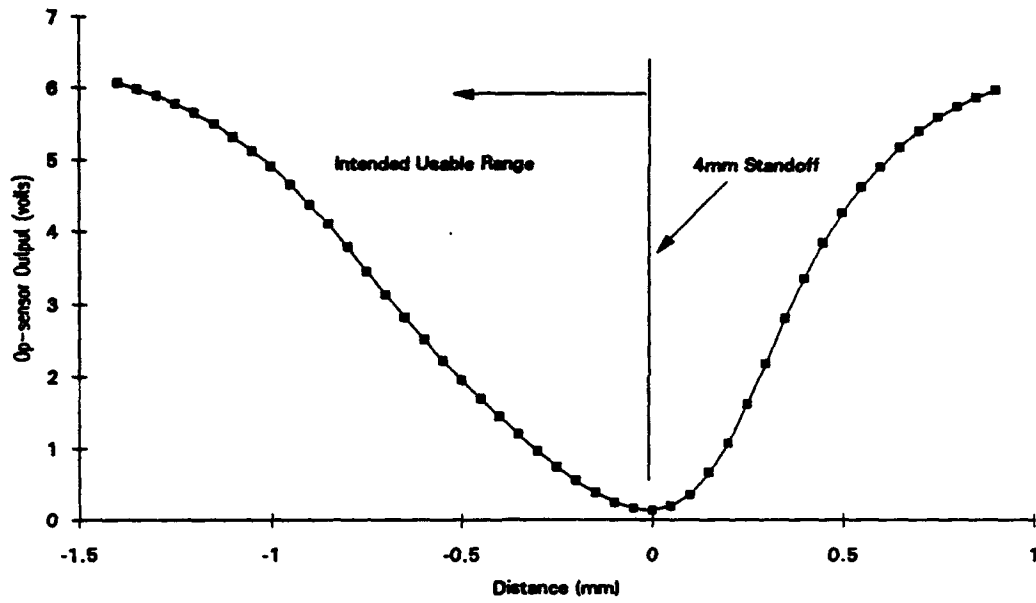

Figure 3. Output of an Optical Sensor (HPCS-1100)

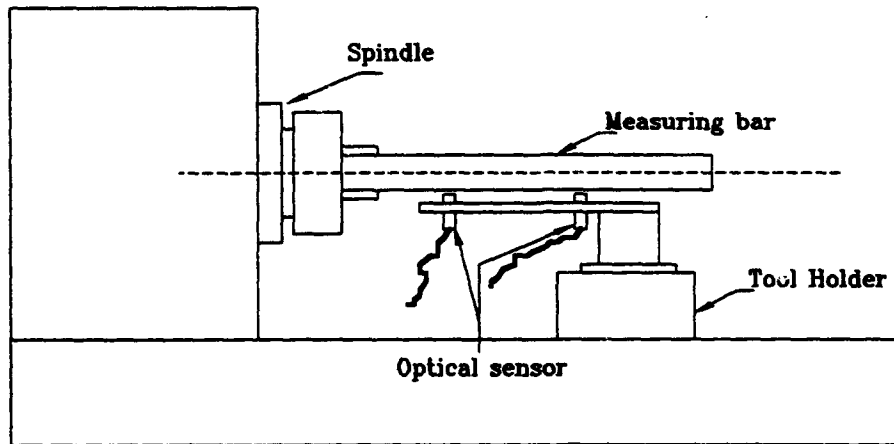

Figure 4. Optical Sensor Test Setup on a Lathe

The previously expressed concerns about optical sensors, and the problems with the commercial capacitance sensors just mentioned eventually led to the development by API of a new, low-cost, thermally stable and robust capacitance sensor.

Figure 5 is the schematic of the API capacitance sensor. The basic difference between the commercial capacitance gage and the API sensor is that the former uses a bridge balancing principle while the later uses a differential measurement principle. The result is that the latter is much simpler, is less costly to build and has a greater operating range. A drawback is that the sensitivity of the new sensor is about ten times less than with the bridge versions. Nevertheless, the sensitivity of the new gage is considered adequate for this application.

Output drift of a capacitance sensor is typically caused by thermal instability of the amplifier circuits and of the environment. To eliminate the drift problem, a specially designed compensation circuit was built into the new sensor. By employing as a reference inside the sensor assembly a matching capacitance circuit and matching measuring element, the drift effect of the primary sensor element is canceled out. See Figure 6. As a result, the API capacitance gauges experience only one-tenth the amount of drift that most commercial capacitance gauges exhibit. With all the basic circuits located within the gauge head, the API gauge can measure with a much higher dynamic bandwidth and with better signal-to-noise ratio than most commercial gauges.

Figure 7 depicts a drift test of an API gauge using a 10°C temperature variation over a 2 hour period. The gauge showed a thermal stability improvement of ten times over that of any of the commercial units.

Figure 8 shows the setup of five of these API capacitance gauges when used for machine tool spindle growth measurements.

The following are the characteristics of the API capacitance gauge:

Measuring range:	0.05 mm to 0.8 mm
Resolution:	0.10 μm
Linearity:	better than 1% of full range
Thermal drift:	less than 100 ppm per °C
Standoff:	0.05 mm nominal
Frequency response:	20 kHz

4.2. Thermal Sensor Selection & Development

After testing and comparing three different types of thermal sensors, i.e., thermocouple, thermister and integrated circuit (IC) thermal sensors, the IC sensors were selected for this program. Reasons for the selection of IC sensors are that they are:

- (a) more rugged, stable and accurate than thermisters,

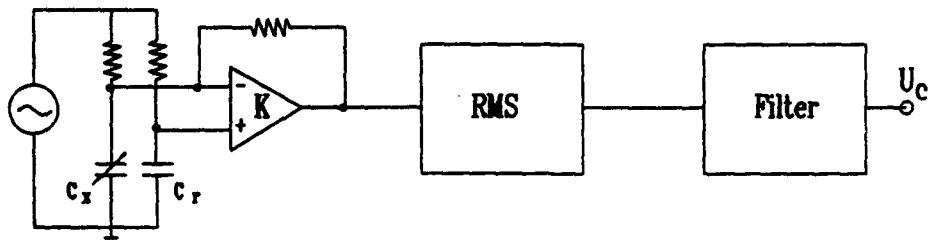

Figure 5. Schematic Diagram of an API Capacitance Gauge

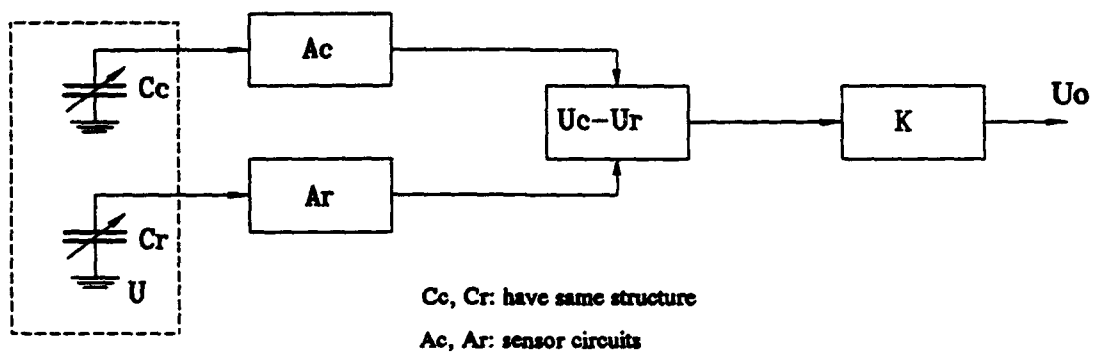

Figure 6. Block Diagram of a Capacitance Gauge Circuit

API CAPACITANCE GAGE TEST RESULT

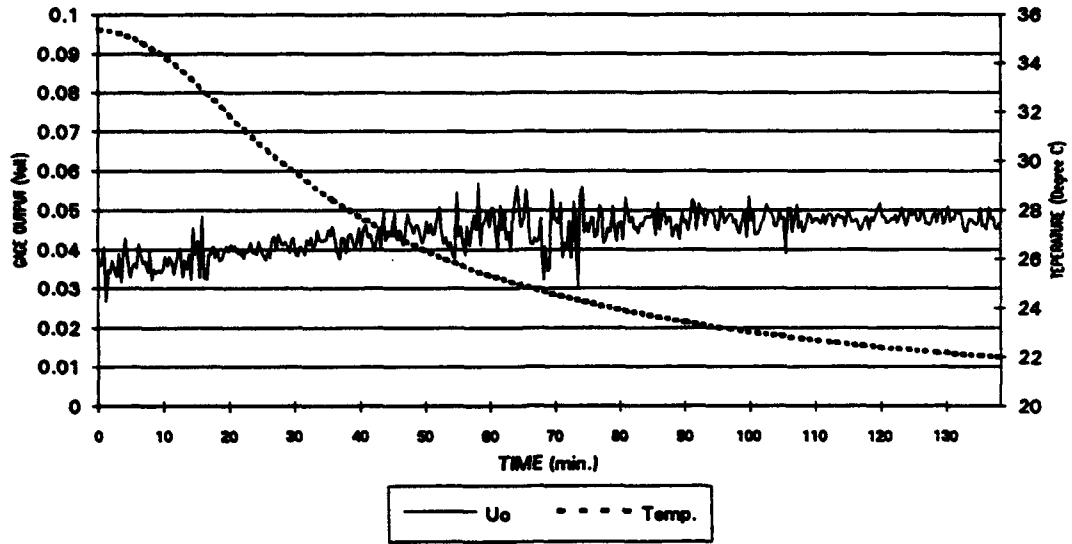

Figure 7. Thermal Drift Test Results of an API Capacitance Gauge

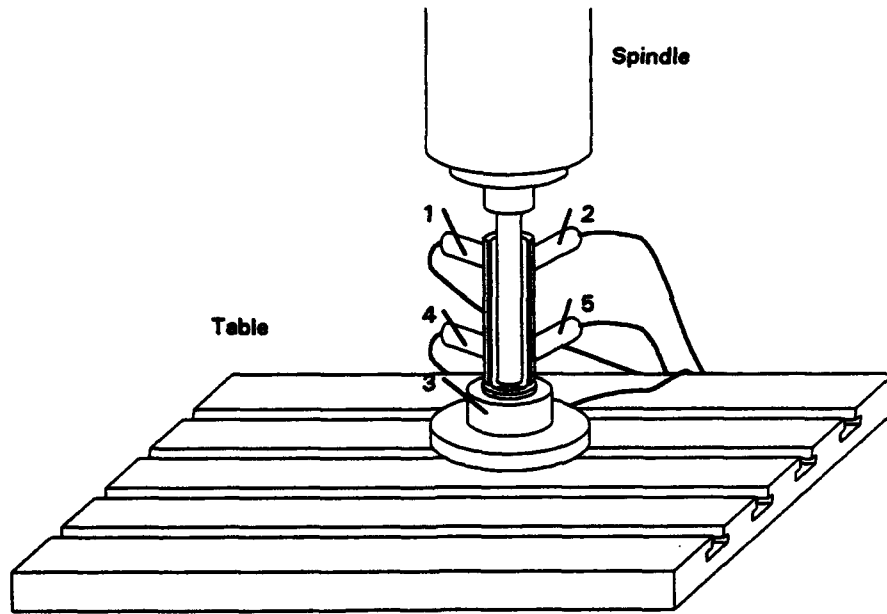

Figure 8. Capacitance Sensor Setup with the Mounting Fixture

- (b) more suitable for the temperature range and sensitivity needs associated with this machine tool application than thermocouples and
- (c) easy to install.

The following are the characteristics of the IC sensor tested:

Accuracy:	± 0.1 °C
Linearity:	0.1 °C
Operating range:	-25 °C to +105 °C
Supply voltage:	+4 Volt to +30 Volt dc

A unique magnetic base design was developed to house each thermal sensor. Figure 9 shows an IC thermal sensor embedded inside a magnet. To use the sensor, the operator simply places the sensor against a ferrous machine tool surface and the magnetic force automatically holds the sensor in place.

4.3. Sensor Interface Controller Development

A high-performance computer interface controller was developed for the sensor system. It incorporates a 14-bit D/A converter, parallel interface, and an interrupt-driven DMA (direct memory access) interface driver. Using a multiplexing technique, the controller is capable of handling as many as 27 thermal sensors and 5 capacitance sensors simultaneously. Four control lines from the computer are used for the channel select. Figure 10 is a schematic diagram of the system showing the controller.

4.4. User-Friendly Software Development

User-friendly interactive software was developed for the sensor interface, system setup, data acquisition and analysis functions. Figure 11 illustrates the software structure. There are four interactive display screens to facilitate use of the system. These screens facilitate sensor setup, data collection, programming and data analysis. An example of the sensor setup screen is presented in Figure 12. Sensors 1, 2, 3, 4 and 5 represent the X1, Y1, Z, X2 and Y2 outputs of the five capacitance gauges. They monitor the distance to the surface of the test mandrel which is a polished 1" diameter x 8" long steel rod mounted in the spindle of the machine. During setup, the readouts from all five gauges are continuously displayed on the screen, thus giving visual feedback to the user as he/she adjusts the sensors into position. The total required setup time is about 5 minutes.

The software program provides the following user selectable functions on the main screen:

Data Collection

One can select the sampling interval, test running time and the output filename. During data collection, the display will show the outputs of all five capacitance gauges and the user-selected thermal sensors. To eliminate the influence of the spindle vibration caused by off-center chucking of the mandrel, the outputs of the capacitance gauges are read and averaged 500 times over 10 spindle revolutions

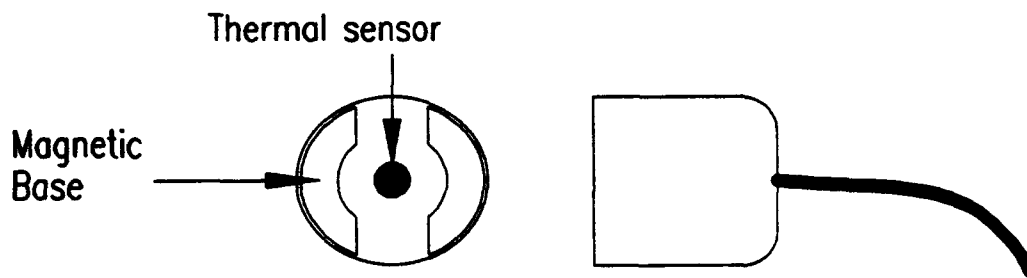

Figure 9. IC Thermal Sensor with Magnet Base

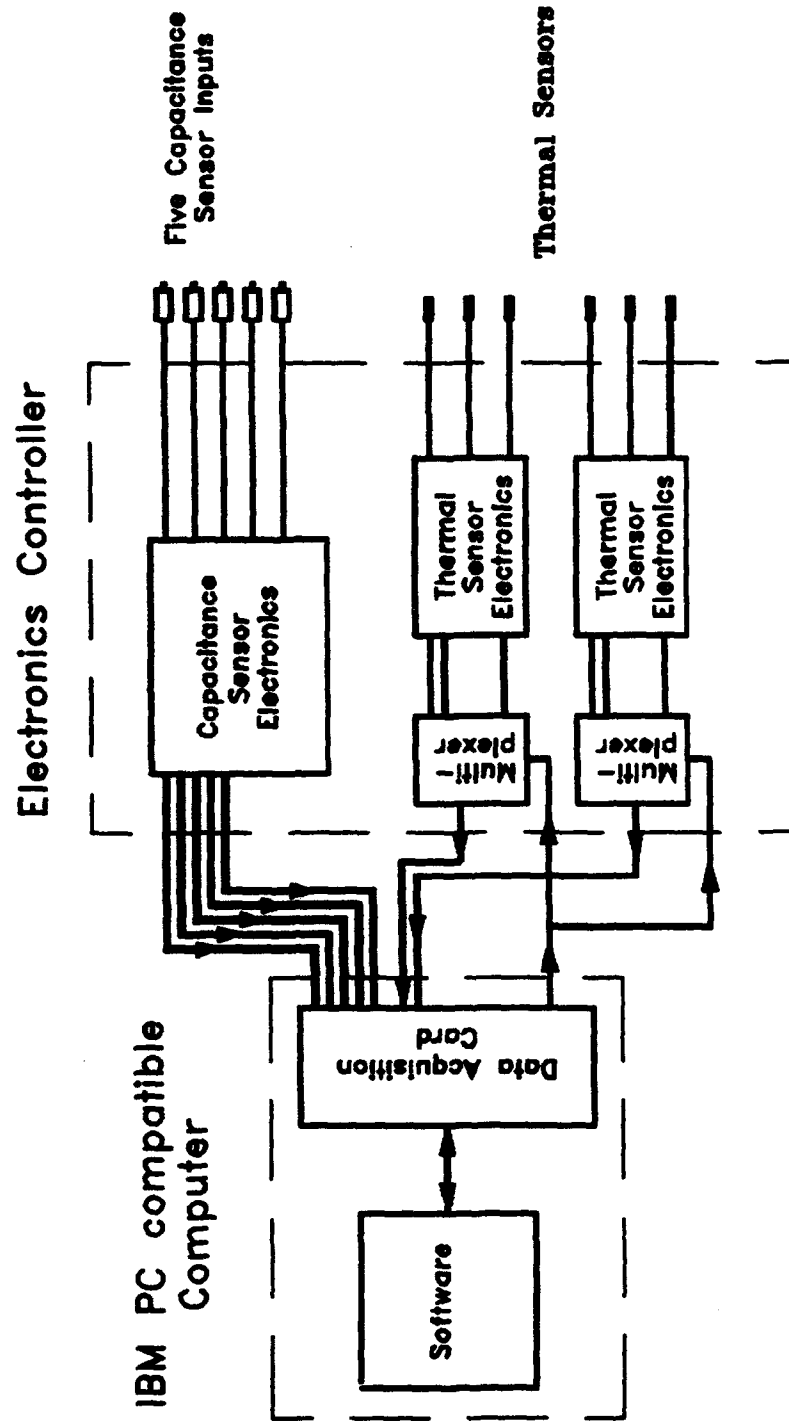

Figure 10. Schematic Diagram of Electronics Controller

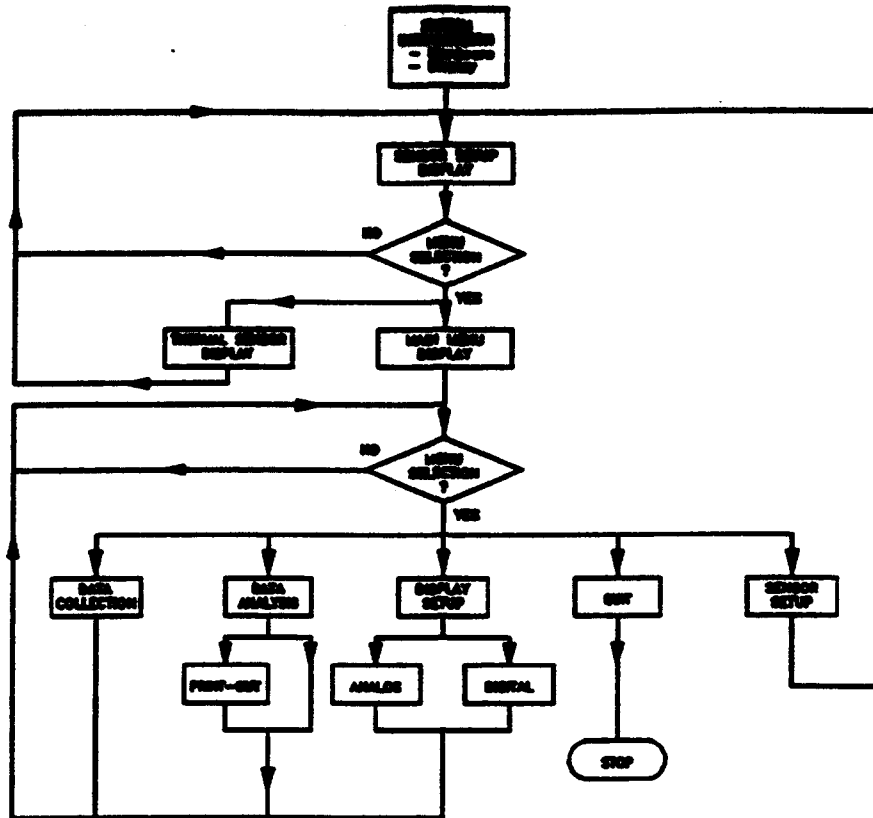

Figure 11. Block Diagram of Software Structure

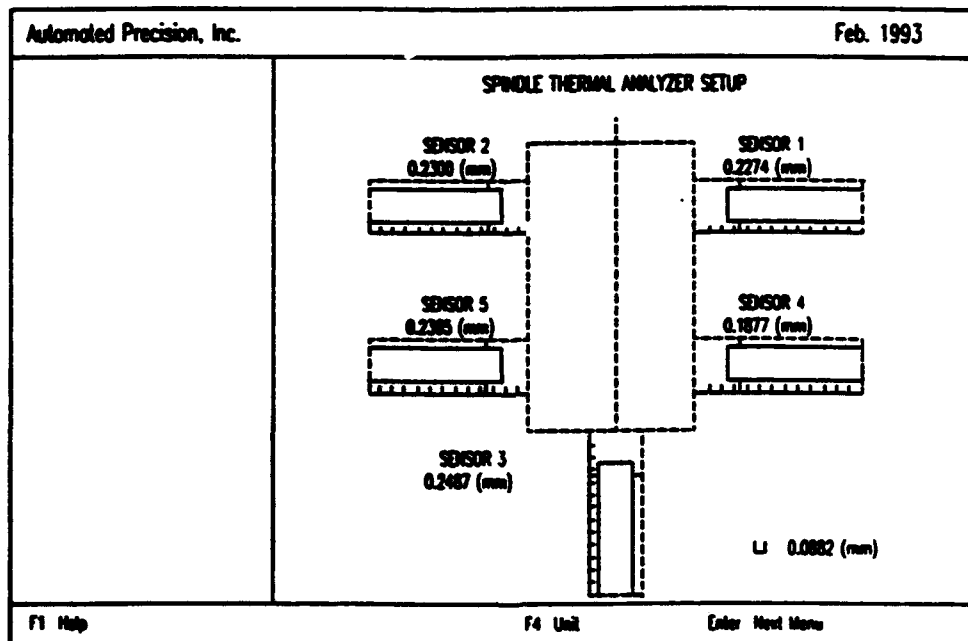

Figure 12. Capacitance Sensor Setup Screen

during each sampling interval. The system is capable of detecting the actual rpm of the machine spindle and sets the sampling frequency accordingly.

Data Analysis

At the conclusion of the data collection function, the results will be displayed and analyzed using the analysis screen. The data points are computed to yield the X, Y, Z, pitch (using a combination of the X1 and X2 sensor outputs) and yaw(using a combination of the Y1 and Y2 sensor outputs) movements of the spindle. Hard copies of the results can be obtained through use of dot matrix or laser printers.

The system was tested at many places, and comments were collected. Overall, the hardware and software received favorable comments from its users. Suggestions for improvements were noted and these ideas were incorporated in subsequent versions of the Spindle Thermal Characterization and Compensation System.

5. THERMAL MODELING AND THE COMPUTER AIDED SENSOR CORRELATION SYSTEM (CACS)

5.1. Analytical vs. Parametric Thermal Modeling Approaches

Two classical approaches to modeling the thermal distortion of machining centers are the analytical (finite element) approach, and the parametric (experimental) approach. In the analytical approach, it is assumed that the machine structure is homogeneous and that the heat dissipation throughout the structure follows the laws of thermal conductivity. These assumptions are then used to establish an ideal analytical model (i.e., finite element model) of the machine. Users of this model first identify the locations of the heat sources and estimate the amount of heat dissipated. Then the model predicts the total thermal distortion [5].

Unfortunately, researchers [6] have found that the boundary conditions of two mating surfaces, which often greatly affect the predicted thermal transmissivity, are very difficult to estimate with good accuracy. In addition, it is also difficult to estimate the amount of heat generated and dissipated without making actual measurements on the machine. The lack of precise knowledge of the many boundary conditions and the difficulties associated with heat dissipation factors often cause skepticism about the results obtained from this analytical approach. Consequently, the analytical approach is used mainly for trend predictions rather than for qualitative predictions.

The work presented in this report has, therefore, been based on the parametric modeling approach which requires no knowledge of the machine configuration, structure and boundary conditions. The approach uses actual measurements of the thermal and growth effects of the machine spindle. Through a sequence of well designed tests and experiments, the approach correlates the thermal and spindle growth information and establishes a mathematical (or parametric) model of the machine. Once verified, the model

can then be used in real-time with thermal measurements to predict the thermal growth of the machine and movement of the spindle.

The machine must be exposed to a variety of operating conditions and environmental conditions during the modeling process in order to build up a robust model. In addition, the accuracy of the model is very dependent upon the performance of the measuring instruments. Fortunately, all these are easily controlled with greater certainty than would be possible with the analytical approach. Because of this, the parametric approach has become more widely accepted by industry. Based on the results of this work, the accuracy achieved by the parametric approach was well above 80%, several times more accurate than could be expected from the analytical approach.

5.2. Spindle Thermal Growth Measurement

Extensive tests of the spindle thermal growth were carried out on various types of machining centers during and after the development of the initial sensor system. The tested machining centers included:

- an Autonumeric MVC-10 vertical spindle CNC machining center,
- a Monarch VMC-75 vertical spindle CNC machining center,
- a Sundstrand series 20 Omnimill horizontal spindle CNC machining center,
- a Producto A-1738 vertical spindle CNC machining center, and
- an Olofsson dual-vertical spindle turning center.

Except for the Sundstrand machine, these machining centers are classified as "C" type vertical machining centers. It was discovered that the major direction of spindle growth of the "C" type machines is along the Z-axis. This growth is about three to four times the growth in the direction of the X- and Y-axes. As a consequence, most of the data shown here are for growth along the Z-axis.

The thermal tests for each machining center typically consisted of:

- Warm-up run - Running the spindle after the spindle was shut down overnight,
- Run with various spindle speeds - Running the spindle at different speeds after the machine is fully warmed-up,
- Production cycle run - Simulating the production cycle, including starting and stopping the spindle frequently,
- Cool-down run - Monitoring the spindle movement after the spindle was stopped.

Figure 13 shows two observations of the Z-axis warm-up spindle growth of the Autonumeric machine. Spindle speeds were 1000 and 2000 rpm. Figure 14 shows a typical warm-up and cool-down test of the Autonumeric machine in both Y- and Z-axes. It is common to find that the warm-up growth is more rapid than the cool-down growth/contraction since the former is a result of "forced" heat transfer while the latter is a result of "natural" heat conduction and convection.

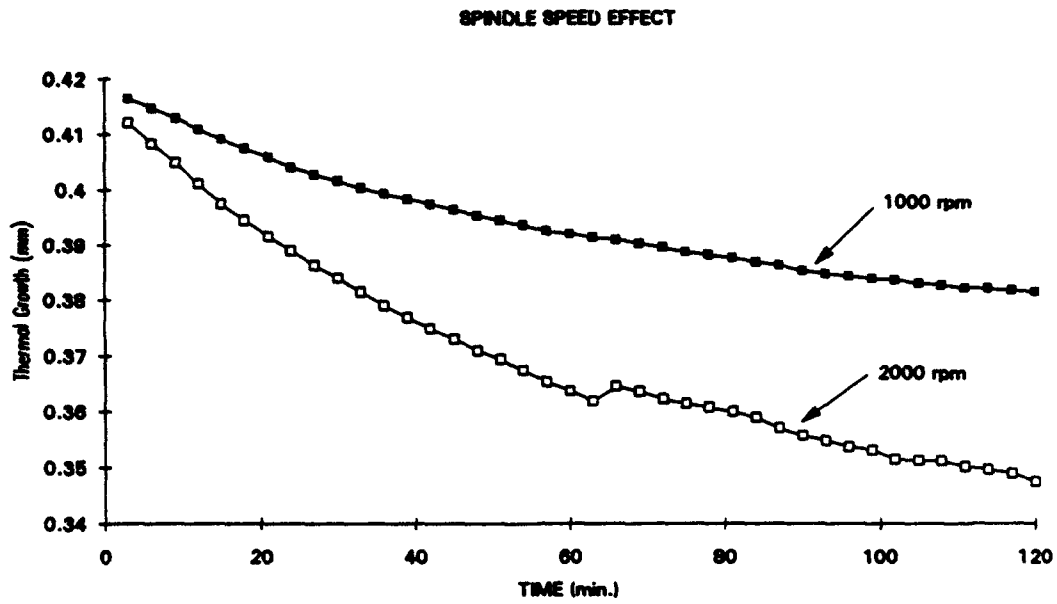

Figure 13. Effect of Spindle Speed Variation

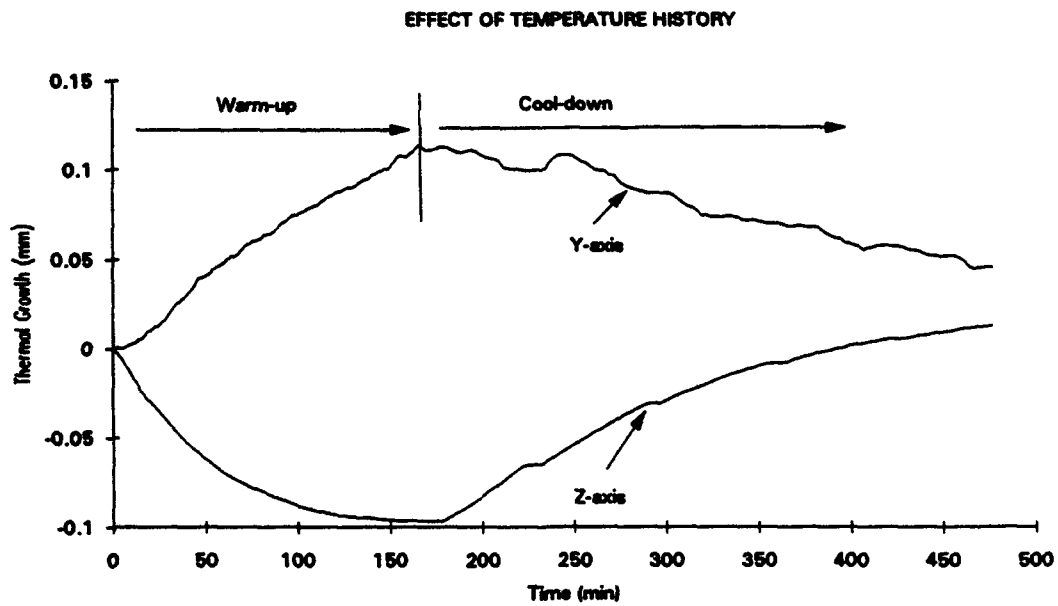

Figure 14. Effect of Temperature History

Environmental effects can also significantly affect machine growth. This is shown in Figure 15. The Sundstrand machining center was under a routine warm-up test when suddenly, at about 180 minutes into the test, a large bay door about 200 feet away from the machine was opened. The door opening allowed chilled air from outside to rush in and upset the machine growth pattern. As can be seen from the figure, most temperature gauges responded to the sudden drop in temperature at 180 minutes. In the meantime, the capacitance sensors also picked up rapid changes in the spindle position (large dips shown by S1, S2, S3 and S4). Shortly after the door was closed, both the temperature and the spindle positions returned to their previous status. Although there was insufficient data to explain why the Z-axis (monitored by S5) didn't seem to change as much as the other axes, the effect of the environmental temperature fluctuation on the machine growth was vividly demonstrated by this incident.

5.3 Thermal Modeling

It was discovered during the many tests on different machines that the heat source that seemed to influence spindle growth the most was the spindle bearings. Most modern machines have their spindle motor isolated from the main structure of the machine and, therefore, the heat generated by the motor has less effect than the heat generated by the spindle bearings.

Our findings also indicated that environmental effects, residual thermal effects in the spindle and column, such as embedded heat accumulated during the previous operations gradually dissipating from the mass, and current operating conditions can also greatly affect the spindle growth.

Due to the difference in mass between the spindle and column, the spindle normally heats up and cools down much quicker than the column. This makes thermal modeling very complicated, especially when the machining center is used in a production environment. In a typical production environment, the machine is often subjected to the influence of more complex thermal growth processes, other than simple warm-up and cool-down cycles, and sometimes uncontrolled environmental conditions. These are often the causes of failure of the conventional parametric modeling methods.

Based on these findings, API believed that the modeling had to be performed in an environment that the machine was intended for. As a further consideration, the residual thermal effect and the speed sensitive effect which could be measured using differential thermal measurements along the machine spindle and column should be an included parameter in any newly developed thermal modeling technique.

Subsequently, a new multiple regression, differential thermal parameter model was developed.

SPINDLE THERMAL STABILITY TEST

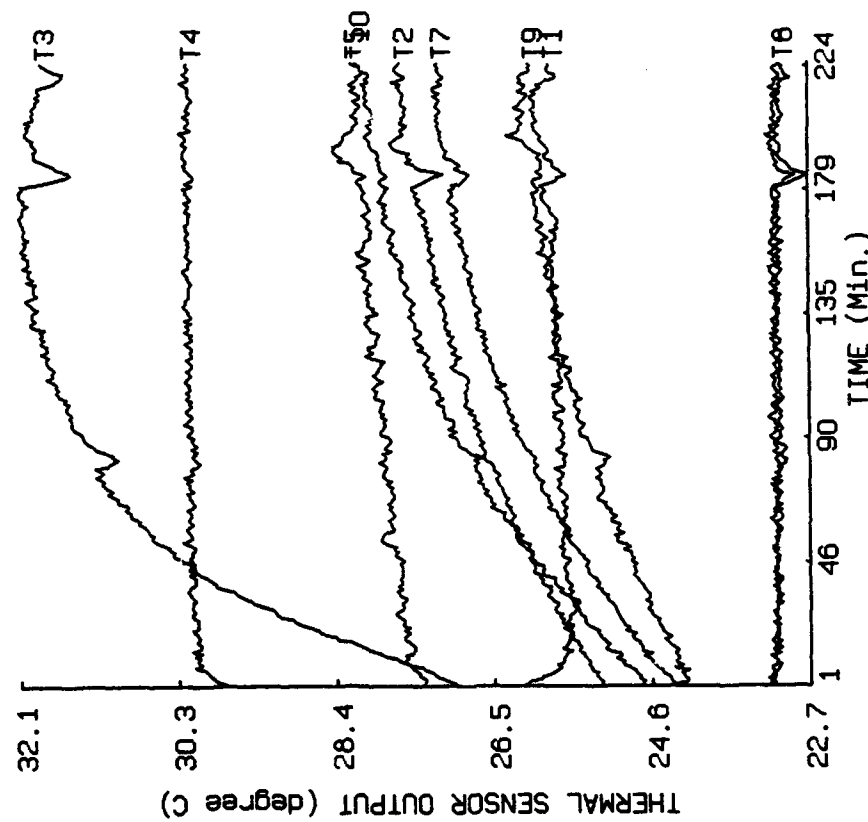
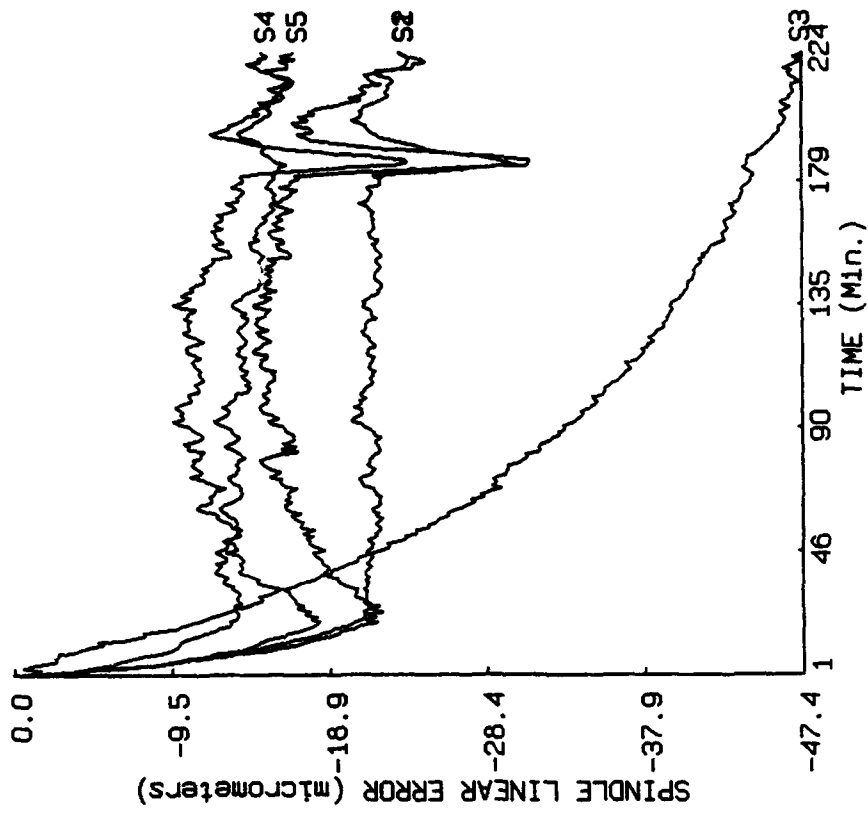

Figure 15 Effect of Environmental Temperature Variation

The general form of the model for a single axis is:

$$E_{im} = A_{0m} + A_{1m}\Delta T_{ie} + A_{2m}\Delta T_{ie}^2 + A_{3m}\Delta T_{id} + A_{4m}\Delta T_{id}^2$$

Where:

E_{im} = thermal growth errors predicted, where m is machine axis, i.e. X,Y,Z...
 $A_{0m}, A_{1m}, A_{2m}, A_{3m}, A_{4m}$: coefficients of model,

$\Delta T_{ie} = t_u - t_{ie}$
 t_{ie} is the environment temperature
 t_u is the selected thermal sensor,

$\Delta T_{id} = (t_u - t_j)$
 $l, j =$ thermal sensor number,
 $i =$ time stamp.

The equation calls for the use of multiple thermal measurements for all key heat sources of the machine. In order to ensure that all key locations are measured, it is common to find a large number of redundant thermal sensors used initially. At NIST [3], 50 thermal sensors were initially applied to the machine. After days or sometimes weeks of thermal testing, a special computer algorithm was used to correlate the thermal and displacement sensor outputs. The results were then used to identify the sensors that had a high correlation with machine growth, and to eliminate those that had a low correlation. The elimination decision process was very lengthy and partly done manually. The final number of sensors selected usually ranged from four to five.

At the University of Michigan [5], approximately 50 thermal sensors were used in the initial stages of the test. However, the UM sensor elimination process was done in two steps. The first involved the use of a similar correlation program to identify the key sensors. The second step was a stepwise regression analysis which identified the cross-correlation results between thermal sensors before they were further reduced. Both procedures were tedious and the results often relied on the judgment of the operator.

To be able to automatically and effectively reduce the number of the thermal sensors on the machine is a necessary part of any commercially viable spindle-thermal error analysis and compensation system. Users of the system should not find the modeling process too cumbersome to perform nor the analysis too theoretical to understand. Consequently, as a part of the analysis and compensation system, API developed a user-friendly computer-aided sensor correlation (CASC) algorithm to assist in the optimization (minimization) of the number of thermal sensors. CASC is a real-time user-interface program designed to help the user to identify the key locations of the thermal sources on the machine as well as optimize the number of thermal sensors required. The initial number of thermal sensors used in the API system was 20 and the final number, based on our many tests, was only 4 or 5.

5.4 Principle of Sensor Correlation

Correlation analysis is a statistical method used to reflect the degree of the linear relationship between two variables. The correlation coefficient denoted by γ is defined as:

$$\gamma = \frac{\sum (x_i - \bar{x})(y_i - \bar{y})}{\sqrt{\sum (x_i - \bar{x})^2 \sum (y_i - \bar{y})^2}}$$

Where:

x_i, y_i = values of variables x and y ,

\bar{x}, \bar{y} = mean value of x_i and y_i ,

γ = correlation coefficient between x and y .

The value of the correlation coefficient γ is zero if x and y are random occurrences and are unrelated to each other. The value of γ is 1 if they are totally related, i.e., if $y = f(x)$. See Figure 16.

In the case of CASC, let γ be the correlation coefficient between the thermal sensors and the spindle-axis growths. Then γ has the form:

$$\gamma_{ik} = \frac{\sum (t_{il} - \bar{t}_l)(d_{ik} - \bar{d}_k)}{\sqrt{\sum (t_{il} - \bar{t}_l)^2 \sum (d_{ik} - \bar{d}_k)^2}}$$

Where:

t_{il} = values of thermal sensor t_l , l is sensor number from 1 to 20,

\bar{t}_l = mean value of t_{il} ,

d_{ik} = values of capacitance sensor d_k , k is sensor number from 1 to 5,

\bar{d}_k = mean value of d_{ik} ,

γ_{ik} = correlation coefficient between t_l and d_k ,

i = time stamp.

CASC calculates the correlation coefficients between the thermal drift as measured by each capacitance gauge and the temperature as measured by each thermal sensor. It then prioritizes the thermal sensors (from high to low) based on the γ values. Figure 17 illustrates the results of the Z-axis correlation, temperature measurements against Z-axis growth, produced by CASC on the Monarch machining center. The correlation values are shown as bars above the horizontal line while the bottom half of the graph shows the actual temperature range measurements. The sensors were prioritized based on their γ value, and plotted with the highest value sensor on the right. As can be seen, thermal

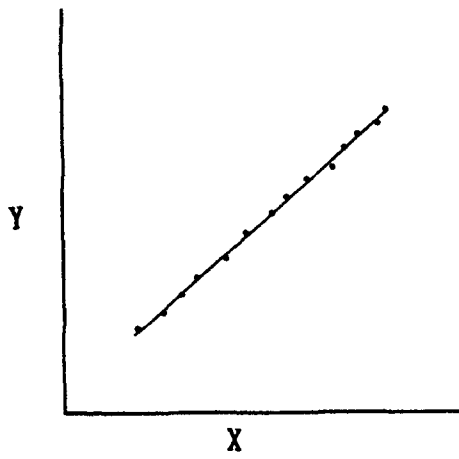

$r = 1$

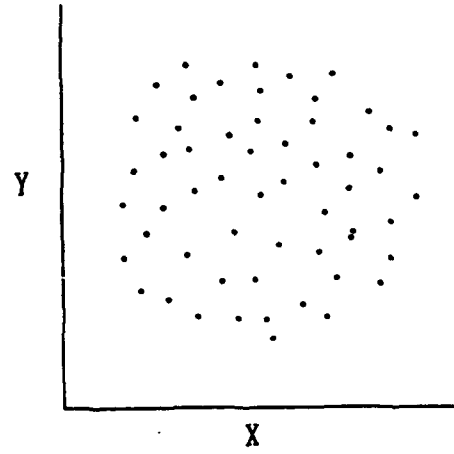

$r = 0$

Figure 16. Concept of Correlation Coefficient

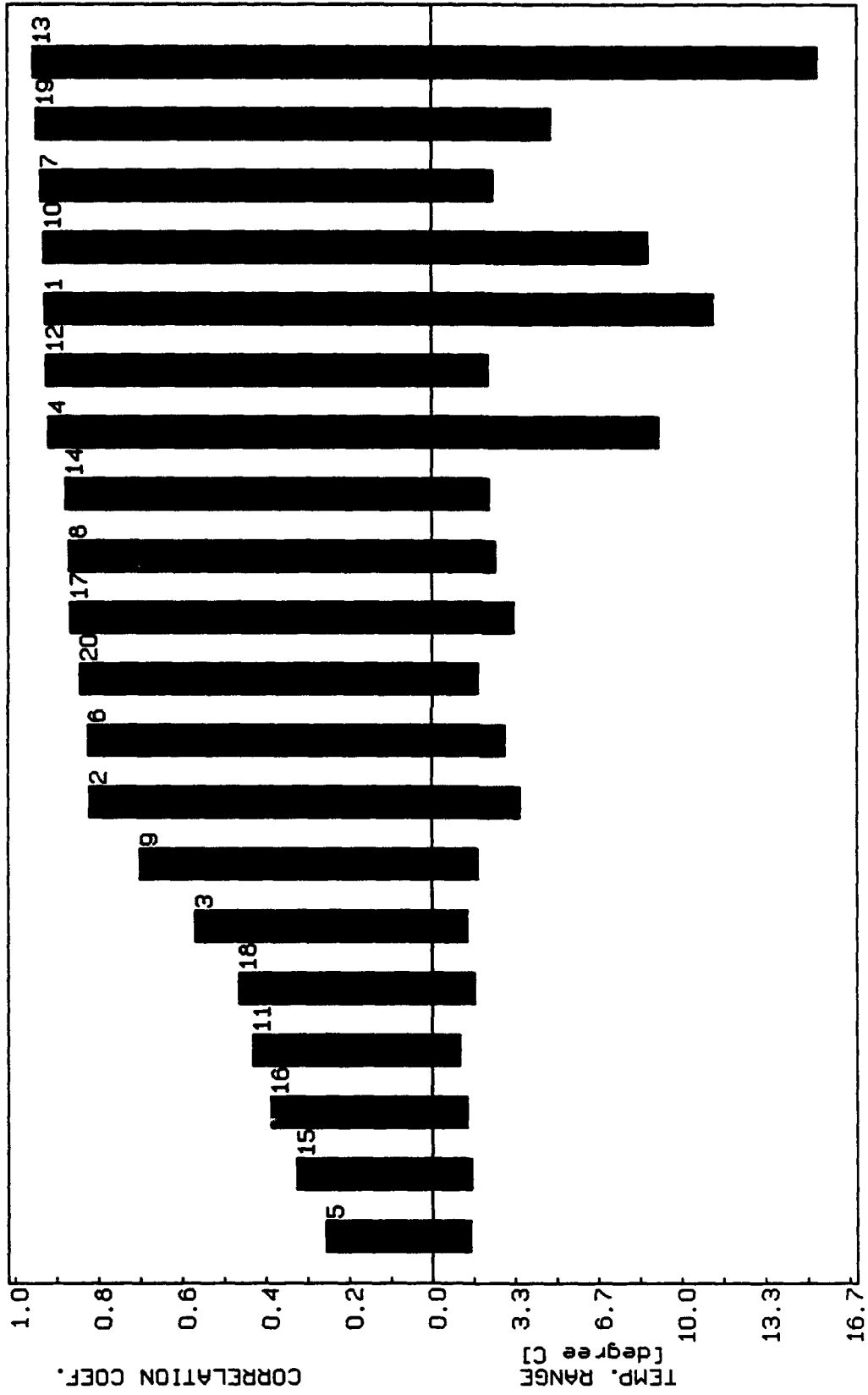

Figure 17 CASC System Graphics Display

sensor #13, which had the highest temperature increase, with +15 °C, also had the highest γ value. It was located at the spindle nose, closest to the lower spindle bearing. CASC showed that sensor #13 had the highest correlation to the Z-axis growth of the machine spindle. Figure 18 illustrates the various thermal sensor locations on the machine.

It is important to realize that higher temperature measurements do not automatically imply higher γ values. As is illustrated back in Figure 17, sensor #7 experienced less temperature increase, but was shown to have a higher γ value than that of #1. This implies that the CASC provides a measure of quality, not quantity.

Automatic sensor selection using purely γ values could be misleading since the locations of the sensors on the machine would not be a factor in the evaluation process. In other words, there could be sensors that were located at places where they were simply measuring the same heat source, and both would present a high γ value. Such a pair of sensors would be #13 and #10. To prevent this condition, it is necessary for CASC to establish a second correlation process to check the correlation between thermal sensors. This process is referred to as autocorrelation, in other words, correlation between the same type of variable, in this case thermal variation.

For this purpose the autocorrelation coefficient α is defined as:

$$\alpha_{ik} = \frac{\sum (t_{il} - \bar{t}_l)(t_{ik} - \bar{t}_k)}{\sqrt{\sum (t_{il} - \bar{t}_l)^2 \sum (t_{ik} - \bar{t}_k)^2}}$$

Where:

t_{il} = values of thermal sensor t_l , l is sensor number from 1 to 20,

\bar{t}_l = mean value of t_l ,

t_{ik} = values of thermal sensor t_k , k is sensor number $l < k \leq 20$,

\bar{t}_k = mean value of t_k ,

α_{ik} = autocorrelation coefficient between t_l and t_k ,

i = time stamp.

If two thermal sensors monitor roughly the same heat source, α should be close to unity. Based on experience, we selected 0.97 as the threshold value for α . In other words, if two or more sensors had an α equal to or larger than 0.97, then only one would be selected. The remaining ones would be eliminated in the modeling. As an example, the autocorrelation coefficient of thermal sensors #13 and #10 was 0.985. As a consequence, we would eliminate either #10 or #13 from our final setup.

In summary, the operating procedures of CASC are:

- (a) prioritize the thermal sensors based on the thermal-to-displacement correlation coefficient value, γ ,

T5, T12 and T17 are symmetrically located with T7, T8 and T11 on the other side of the machine

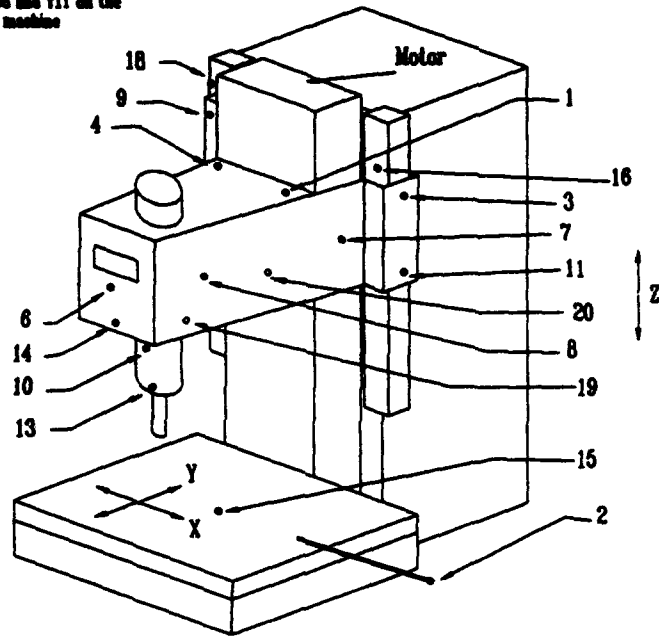

Figure 18. Thermal Sensor Setup on a Monarch Machining Center

- (b) establish a figure-of-merit based on the thermal-to-thermal autocorrelation coefficient value, α , and
- (c) eliminate the redundant thermal sensors that have α values equal to or greater than 0.97.

Conceivably the number of thermal sensors should be increased in order to provide a robust enough model. This decision can be made by looking at the residual value R of the regression analysis. Note that the value of R is unity when a perfect model is established. An iterative modeling process can be used to ensure that the model is optimized. This is evidenced by having a value for R that is close to unity. Typically a second or subsequent model, using the one or two additional sensors having the next higher γ values, are generated. Then the R values of the models are compared. If the value of R improves by more than 1% over the previous model, the iterative process will continue. It is our experience that the optimizing process seldom requires more than five iterations. As an example of how the process works, the initial CASC model may suggest the use of only two thermal sensors, such as one for the table and one for the spindle. After the iterative process, the optimal model may require four sensors, namely one for the table, one for the spindle and one differential pair. Since the process is completely automatic and only deals with data already stored in the system, the whole procedure usually doesn't take more than five minutes.

6. TESTING AND EVALUATION OF THE THERMAL MODELING SYSTEM

Most of the system testing and evaluation was conducted at the program collaborator's site, at The Monarch Machine Tool Company facility in Cortland, New York. Some of the testing and evaluation was conducted at the Olofsson Corporation plant in Lansing, Michigan.

Figure 18, mentioned previously, shows the sensor configuration on the Monarch VMC-45B machining center used for the testing and evaluation. The machine was equipped with a spindle temperature controller, or chiller, capable of delivering temperature controlled oil directly to the spindle bearings and to the axis slides at a temperature held to within ± 2 °C. The maximum speed of the spindle was 10,000 rpm.

One would think that the inclusion of the chiller in the machine setup might have complicated the modeling and compensation process. We found, however, that when the spindle speed was above 3000 rpm the chiller became very ineffective. Also, in order to demonstrate the full effect of the modeling system, most of the tests were focused on operations at speeds of 3000 rpm or higher.

The whole process of modeling and evaluation was conducted in three steps. The first step was data collection on a vertical machining center at The Monarch Machine Tool Company. The second was data processing and modeling at API. And the third was model evaluation on the same machining center back at Monarch.

With the system initially tested at API and several production facilities, it was then taken to Monarch for the first step of data collection on the vertical machining center. For 3 days, large amounts of data was collected which included periods of warm-up, cool-down, random speed tests, short-duration high-speed tests, and short-duration zero speed tests. This was meant to simulate all the different speeds and operating conditions that might be experienced on the machining center. The spindle was found to have four to five times more growth in the Z-axis when compared to the growth along the X- and Y-axes. Thus, for illustrative purposes, the modeling process was focused on the Z-axis growth.

Next, the data were brought back to API and carefully analyzed. The process of sensor elimination and model optimization was performed and results were compared to what would be obtained from the conventional modeling technique, in other words, without using different sensor information. It was discovered that the new model had an average improvement of approximately 15% over the conventional technique. In particular, the new model was able to predict the growth more precisely during random speed operations. See Figure 19. In this particular case, CASC had identified thermal sensors 13, 19, 7 and 4, and differential pairs 13/17 and 10/13 as being appropriate for inclusion in the Z-axis model.

After the analysis and modeling step was completed, the system was brought back to Monarch and set up on the same machine for the third step of the work. The machine was once again programmed to perform all the same warm-up, cool-down and random speed cycles while the system again collected data. However, this time, instead of using the data to establish a model, they were used to make a comparison with the results obtained from the model previously established. Figures 20 through 24 show the results of the comparison at speeds of 3,000, 6,000, 7,000 and 9,000 rpm. As can be seen, the thermal growth was about 60 μm with the maximum error caused by the model being 7 μm . This was an improvement of 88%!

Figures 25 and 26 show results of the comparison under conditions of random speed operation. In both situations shown, the machine was fully "warmed-up" using continuous operation for more than 8 hours. However, as can be seen, even a so called "warmed-up" machine can experience large thermal growth fluctuations simply due to varying operating speeds. Figure 25 emulated a typical "on-machine gauging" cycle, a modern manufacturing process that has generated tremendous interest in the manufacturing community. The steep downward trends on the graph were created when the spindle was suddenly run at high speed. The steep upward trends were created when the spindle was suddenly stopped, a condition that would simulate the start of an on-machine part gauging operation. This clearly illustrates the fallacy associated with many on-machine gauging operations being performed day-in and day-out in many manufacturing facilities, namely, that such measurements consistently provide good data. To the contrary, the machine geometry can significantly change during the course of an on-machine gauging operation! Figure 26 also illustrates the limitation or uncertainty of the present spindle thermal modeling system. The best achievable accuracy is about $\pm 2.5 \mu\text{m}$ in a random speed operation.

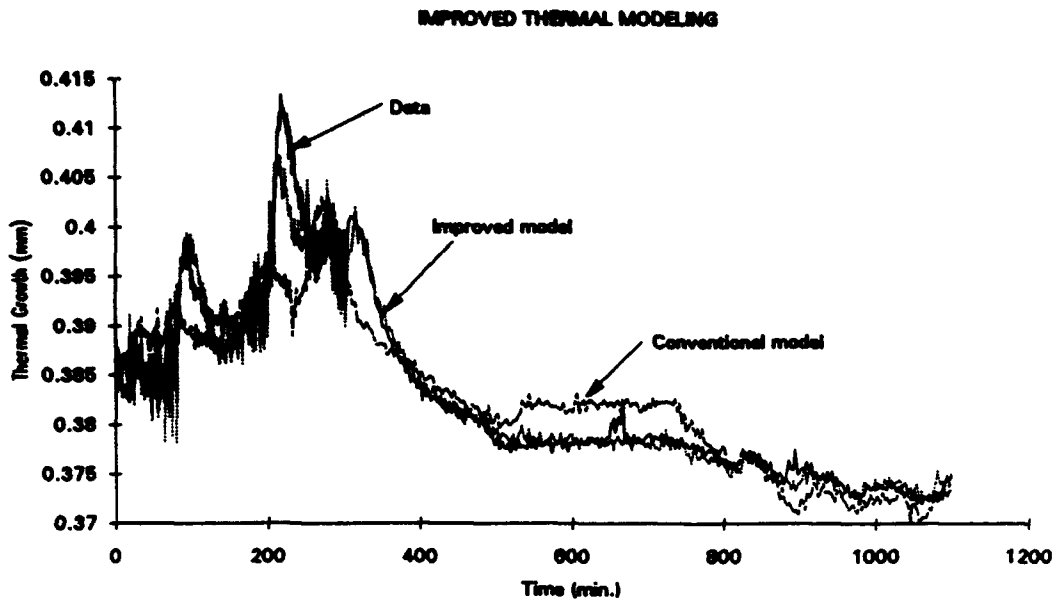

Figure 19. Effect of Improved Model

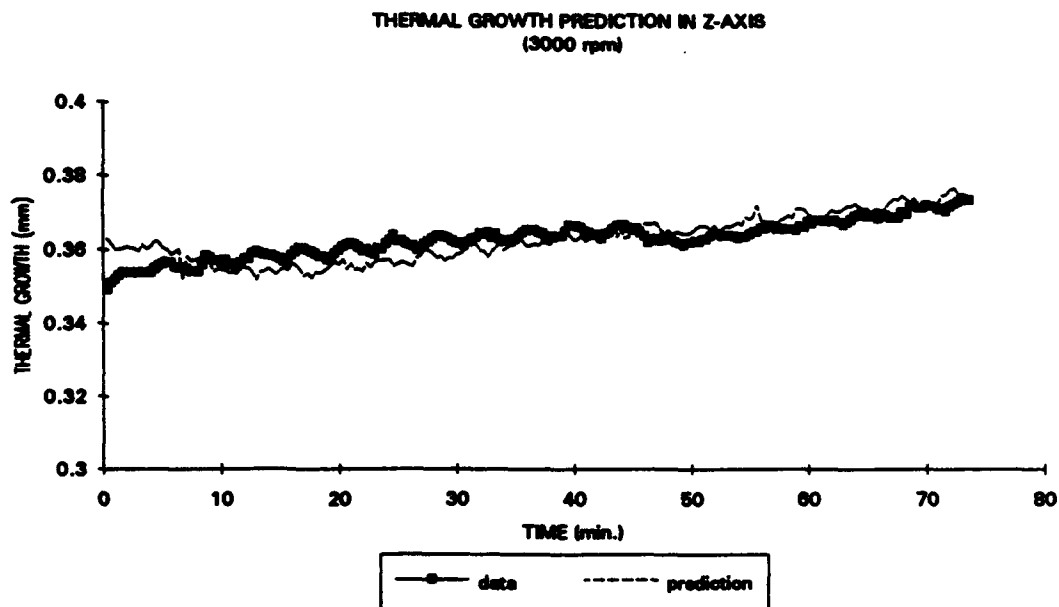

Figure 20. Thermal Growth Prediction in Z-axis (3000 rpm)

THERMAL GROWTH PREDICTION IN Z-AXIS
(9000 rpm, cool-start)

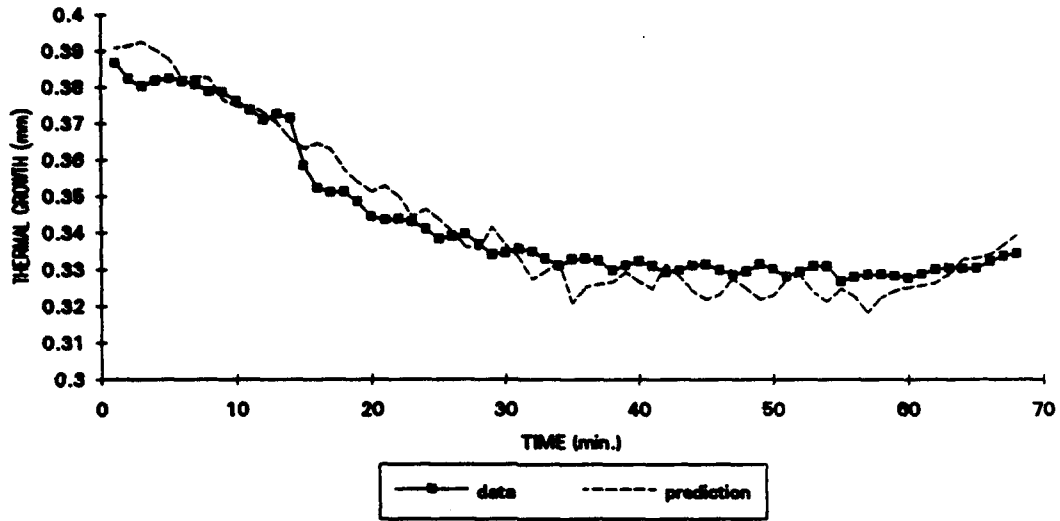

Figure 21. Thermal Growth Prediction in Z-axis (6000 rpm)

THERMAL GROWTH PREDICTION IN Z-AXIS
(9000 rpm, cool-start)

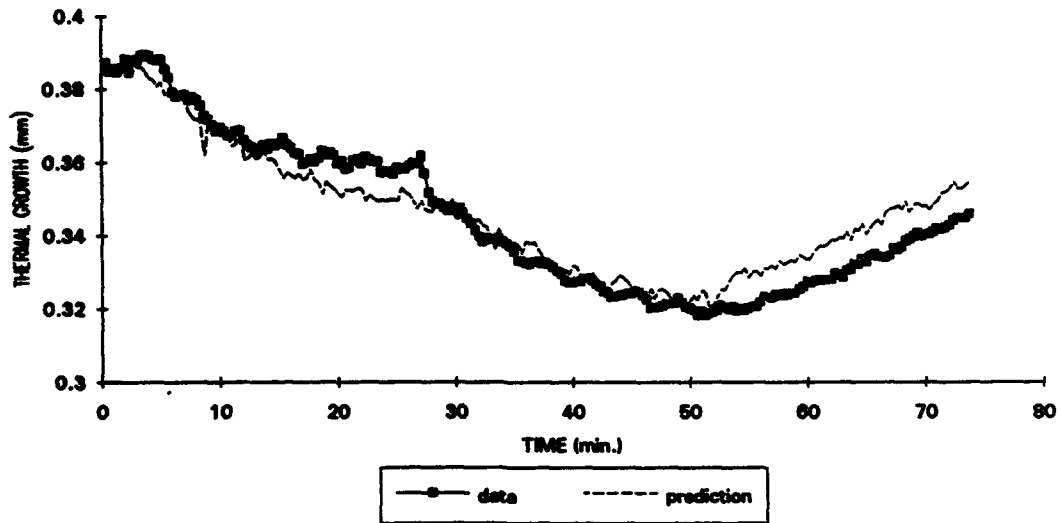

Figure 22. Thermal Growth Prediction in Z-axis (6000 rpm)

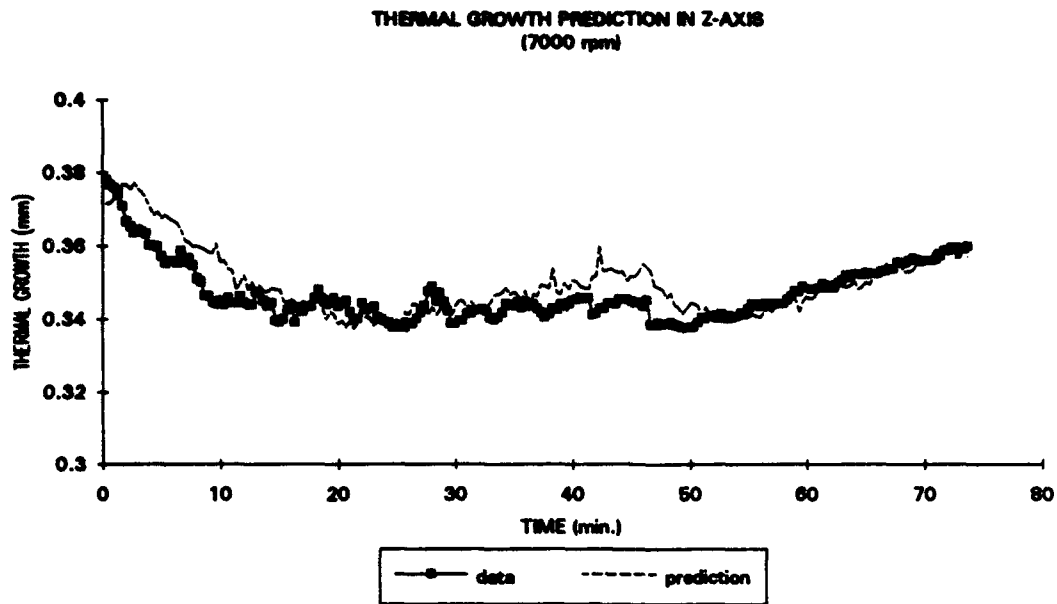

Figure 23. Thermal Growth Prediction in Z-axis (7000 rpm)

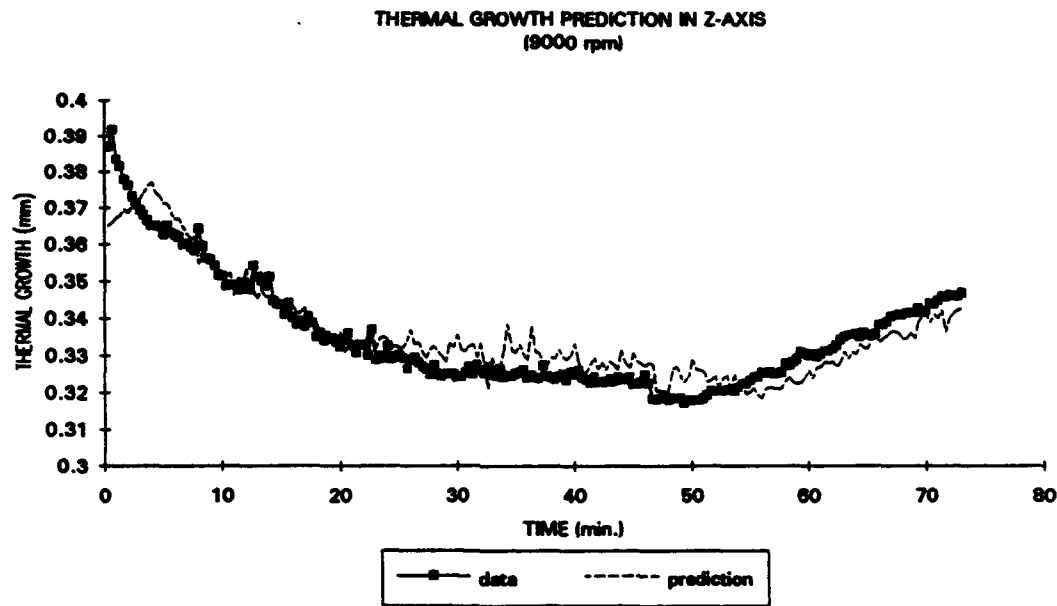

Figure 24. Thermal Growth Prediction in Z-axis (9000 rpm)

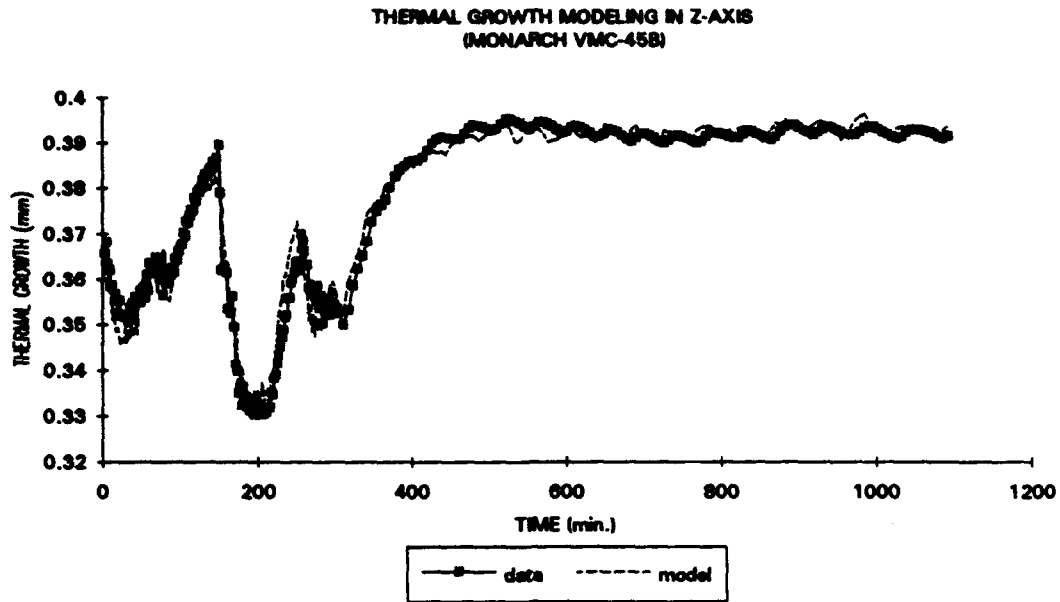

Figure 25. Thermal Growth Modeling in Z-axis

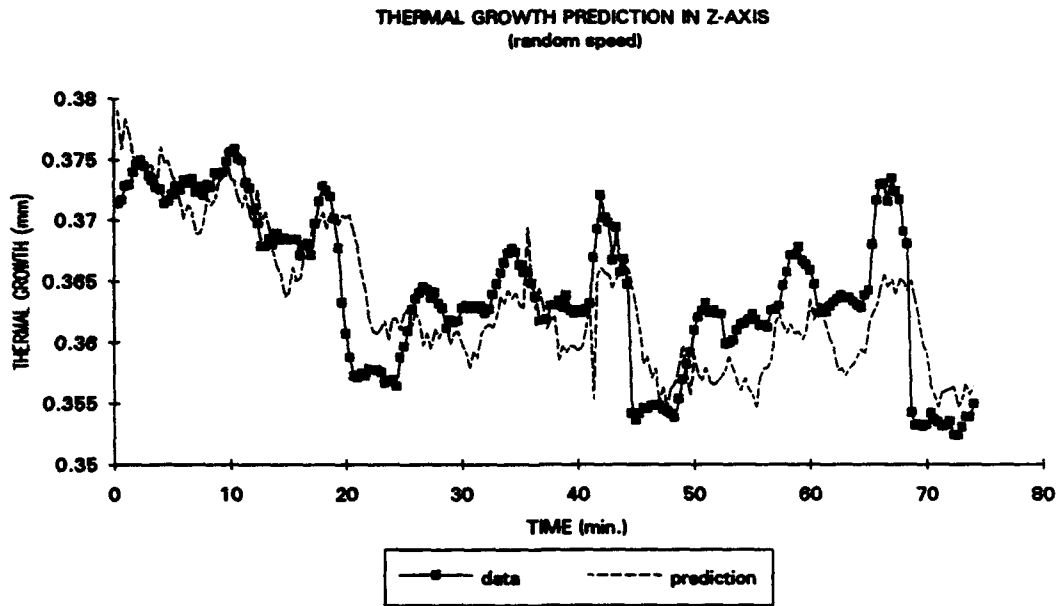

Figure 26. Thermal Growth Prediction in Z-axis (random speed)

Thermal growth tests of the spindle at different Z-axis locations were also performed. It was generally expected that at different spindle positions, the thermal growth characteristics might be different. To verify this, the spindle was raised by 14 inches, almost the full Z-axis column travel, and similar spindle test runs were performed. However, as can be seen from Figure 27, the difference in thermal growth characteristics were not significant at all. This suggests that a uniform model can be successfully applied for this Monarch machine. If significant differences were observed, individual models would have to be established at different positions of the machine. However, based on our testing, this would only apply on some very large machining centers and the improvement may not be significant enough to warrant the lengthy procedure.

Another factor that might have influence on the thermal growth behavior of a machining center is the heat generated by the axis drive systems, especially when the carriages are subjected to near continuous rapid traverse rates. Tests to determine such effects were carried out on the Monarch machine and the Olofsson machine, however, no significant changes to the thermal patterns were observed. See Figure 28.

7. CONCLUSIONS AND DISCUSSIONS

The following statements summarize the major achievements of this work:

- A low-cost, prototype spindle thermal characterization and compensation system for CNC machining centers has been successfully developed. The system consists of five high-performance, non-contact capacitance sensors mounted in an appropriate fixture, a mandrel for mounting in the spindle of the machine, a 20-channel thermal measuring unit, a series of specially designed thermal sensors capable of being magnetically mounted on the machine, a PC-based digital processor and sensor interface, and a suite of user-friendly thermal modeling and sensor optimization software programs, collectively referred to as CASC.
- The prototype system has been successfully tested and implemented on machining centers in the plants of several major U.S. manufacturers. The projected accuracy of improvement is better than 80%.
- The entire modeling process usually takes less than 3 days. This is significantly less time than that taken by any other modeling technique. As a consequence, the use of this system on a machine in a production environment is very practical.
- The hardware and software developed during this program have been successfully commercialized by API. Currently API is marketing this system under the trade name THERMAC. THERMAC is the first low cost, high performance spindle thermal modeling and compensation system designed specifically for use on machines in a production environment. Of course it can be used on machines in a laboratory or tool room setting as well.

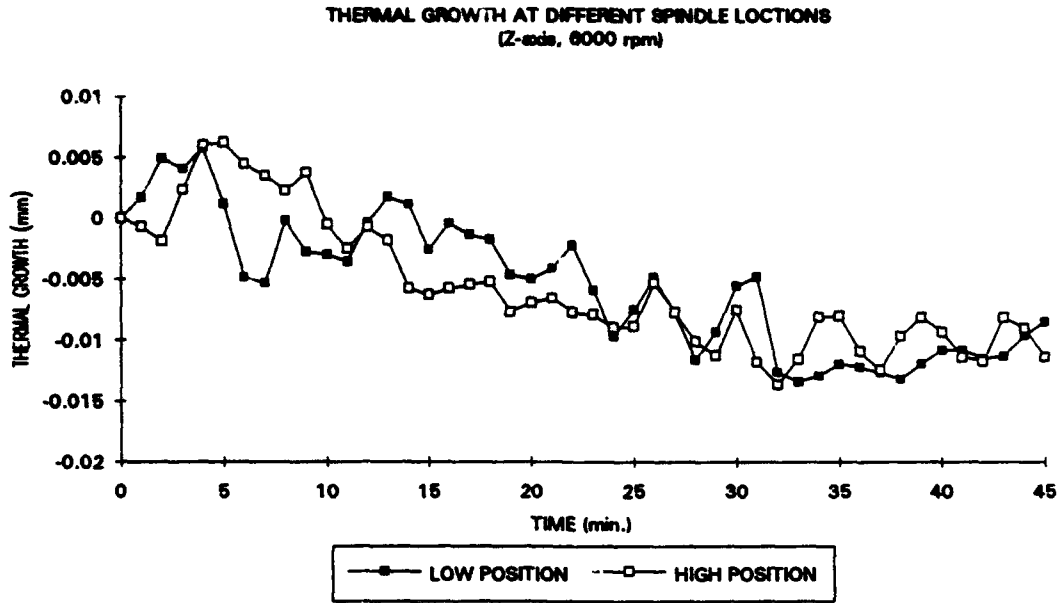

Figure 27. Thermal Growth in Z-axis at Two Different Locations

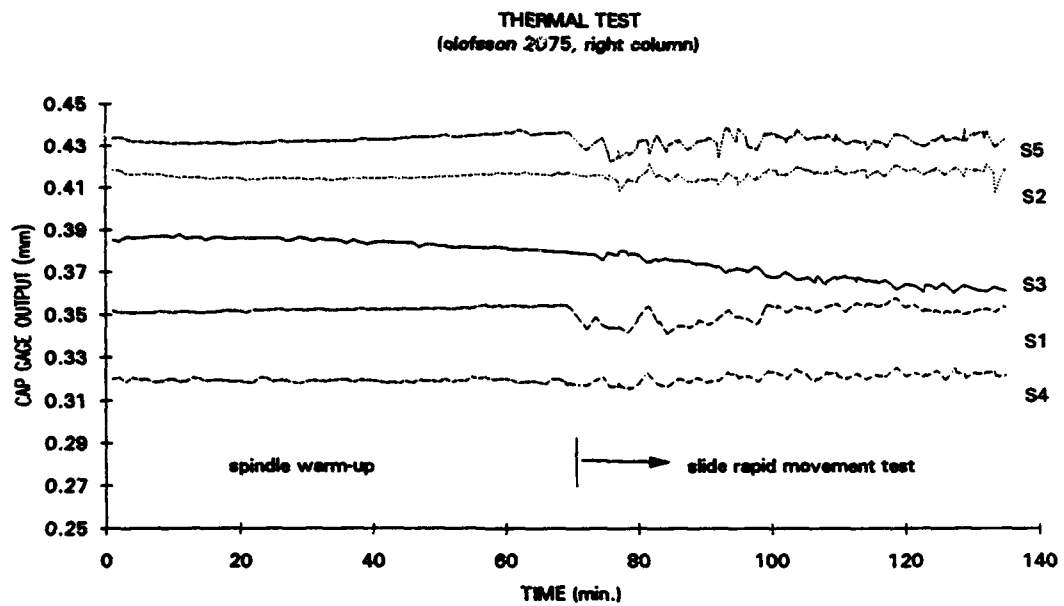

Figure 28. Thermal Test Result with Slide Movement

As noted, the hardware and software of the prototype spindle thermal modeling system was fully tested and implemented on several different machining centers. Most of the tests were performed in production environments. Some were done in laboratory environments. Each test typically ran continuously for 3 to 5 days. The hardware proved to be very robust, reliable, accurate, easy to setup and the software was shown to be very user-friendly. Besides the tests done at Monarch and Olofsson, some of the initial tests were also carried out by engineers from Pratt & Whitney and Ford Motor Company. Thanks is offered to all those involved at each of these facilities for their valuable input and feedback.

Based on our testing, and for a given machine structure and design, there are three sets of factors that dominate the thermal growth pattern of a machining center. They are: (a) the environmental factors, (b) the residual heat factors, and (c) the operating condition factors such as speed, operating cycle, etc. As was vividly illustrated in Figure 15, the machine geometry can be significantly distorted due to any change in the ambient or environmental temperature. Additionally, residual heat inside the machine column and spindle can cause non-linear growth of the spindle, and thus make the prediction and modeling of the thermal characteristics of the machine very complicated. The machine's current and previous operating conditions also significantly affect the thermal growth pattern. Different spindle speeds cause different rates of growth. Different initial thermal conditions also affect the growth patterns, even though the machine is subjected to the very same operating cycles.

The numerous tests of spindle thermal growth that were conducted and the numerous in-depth analyses that followed, led to the introduction under this program of an expanded thermal modeling technique that includes the use of differential thermal sensors. The use of differential sensors was found useful in overcoming uncertainties caused by the three sets of factors noted in the preceding paragraph. Results showed that the new model was able to improve the modeling accuracy by 15%, even when applied in a production environment.

Actual machine tool compensation for thermal growth, using the modeling technique developed here, was not implemented and was not a part of the scope of this project. However, the accuracy of this modeling technique was verified by testing the predicted results against actual measurements. Tests showed that the accuracy improvement of this spindle thermal modeling system is better than 80%. Because of the uncertainty of the thermal growth of machine structures, the accuracy limit of this technique is about 5 μm . In the later stages of this work, particularly relating to the measurements taken at Ford and at Pratt & Whitney, the entire modeling process took only 3 days, including the taking of the geometric measurements. Real-time thermal error compensation can be implemented by interfacing the prototype control unit through a communications link to the CNC controller. By sending the computed compensation value to the CNC controller, the controller can offset the tool position and/or orientation to compensation for spindle growth.

8. REFERENCES

1. Bryan, J.B., "International Status of Thermal Error Research," *Annals of CIRP*, Vol. 16 (1), 1968.
2. Lawrence Livermore Laboratory, "Technology of Machine Tools," UCRL Vol. 5, 1980.
3. "Progress Report for the Quality in Automation Project for FY 90," National Institute of Standards and Technology, March 1991.
4. Chen, J.S., et al., "Real-time Compensation for Time-Variant Volumetric Error on a Machining Center," University of Michigan, Ann Arbor, 1991.
5. Chen, J.S., et al., "Thermal Error Modeling for Volumetric Error Compensation," University of Michigan, Ann Arbor, 1992.
6. Sata, T. , "Analysis of Thermal Deformation of Machine Tool Structure and Its Application," M.T.D.R. Conference Proceeding, Vol. 17, 1976.
7. Week, M., " Computing the Thermal Behavior of Machine Tools Using the Finite Element Method-Possibilities and Limitations," M.T.D.R. Conference Proceeding, Vol. 16, 1975.