



AD-A280 639

NAVSO P-3678



**ESN**

**INFORMATION**

**BULLETIN**

**S** DTIC  
ELECTE  
JUN 23 1994  
**F** **D**

European Science Notes Information Bulletin  
Reports on Current  
European and Middle Eastern Science

*In this issue, reports on...*

Computer Science  
Electronics  
Environment

Materials  
Policy

**DTIC QUALITY INSPECTED 2**

**Special notice...**

- From the Director - iii

6498  
**94-19121**

**94 6 22 059**

## OFFICE OF NAVAL RESEARCH EUROPEAN OFFICE

The mission of the Office of Naval Research European Office (ONR Europe) is to assist the Chief of Naval Research, the Chief of Naval Operations, and the Commandant of the Marine Corps in discharging their responsibilities on matters of general scientific and technical interest to the U.S. Navy in the United Kingdom, Europe, and the Middle East.

To carry out this mission, ONR Europe:

- Maintains liaison with European and other designated government, academic, and industrial agencies conducting research and development (R&D) of naval interest
- Assists U.S. Navy agencies in monitoring specific R&D projects
- Assists U.S. Navy personnel in mutual technology exchange under negotiated agreements
- Disseminates to the U.S. Navy R&D community matters of scientific and technical interest

---

### ORGANIZATIONAL INDEX

Telephone: 44-71-514 + ext.

#### Office of the Commanding Officer and Scientific Director

Code	Ext.		
00	4417	Commanding Officer	CDR Dale A. Milton
01	4508	Director	Dr. John Silva

#### Liaison Officers and Liaison Scientists

13	4131	Computer Science	Dr. Lawrence J. Rosenblum
16	4260	Electronics	Dr. Nicholas Bottka
19A	4413	Naval Air Technology	CDR Dale A. Milton
21	4260	Environmental Systems Technology	LCDR David B. St. Pierre

**U.S. Mail Address**  
PSC 802 Box 39  
FPO AE 09499-0700

**TELEX:** (900) 7402119 ONRE UC  
**OMNET:** ONR.EUROPE

**U.K. Address**  
223/231 Old Marylebone Road  
London NW1 5TH

**FAX:** 44-71-724-7030; 44-71-723-1837  
**MILNET:** ONREUR.NAVY.MIL

# ESN INFORMATION BULLETIN

This publication is an official publication of the Office of Naval Research European Office. It describes research that is being conducted in Europe and the Middle East.

Commanding Officer . . . . . CDR Dale A. Milton, USN  
 Director . . . . . Dr. John Silva  
 Editor . . . . . Ms. Maureen L. Long

**93-09**

## *In This Issue. . .*

**Special Notice... From the Director** . . . . . iii

### COMPUTER SCIENCE

ONR Data Visualization Workshop . . . . . 557  
*L. Rosenblum*

Research Directions in Fluid Flow Visualization . . . . . 569  
*L. Rosenblum*

### ELECTRONICS

The Electronics Research and Development Landscape in the Former German Democratic Republic . . . . . 574  
*N. Botka*

### ENVIRONMENT

Environmental Dimensions of Europe: An Assessment . . . . . 583  
*M. Overcash*

The Structure of Frontal Weather Systems in Western Europe . . . . . 590  
*P. Hobbs*

### MATERIALS

A Process Borrowed from Polymers: Injection Molding of Ceramics at Brunel University, U.K. . . . . 595  
*M. Akinc*

Ceramic Processing Research at the Fraunhofer Institute-Würzburg . . . . . 603  
*M. Akinc*

### POLICY

New Directions for the Estonian Academy of Sciences and Estonian Universities and Institutes . . . . . 608  
*F. E. Russell*

**INDEX—Volume 93** . . . . . 613

**ONR EUROPE REPORTS—1993** . . . . . 617

**Special Notice...**

**From the Director**

With this issue of *European Science Notes Information Bulletin (ESNIB)*, I am assuming responsibilities as the new director of the Office of Naval Research European Office (ONR Europe). This change of management for the European Office comes at a time when massive changes are sweeping through the Department of the Navy, indeed through the entire Department of Defense and the Federal Government itself. These changes are driven by the global political and economic climate.

In addition, they have prompted a natural stage of evolution in the manner by which ONR Europe informs the United States research and development (R&D) community about current scientific activity in Europe, Eastern Europe, the Former Soviet Union, and the Middle East. The scientific community today is firmly entrenched in the electronic age—from massive parallel computers handling modeling computations to electronic transmissions for disseminating information in almost-real-time between distant collaborators. We are moving with these times.

ONR Europe began life as the Office of Naval Research, London Branch. Publications from this office started on 1 January 1947 as the *London Newsletter*. This was changed, on 1 February 1948, to *European Scientific Notes*. In 1987, this became *European Science Notes Information Bulletin (ESNIB)*. Throughout this time, the printed word has been the primary medium for distributing information. In 1992 we began our journey into the electronic age. We began producing *ESNIB* from the Naval Research Laboratory (NRL) in Washington, D.C. Manuscripts were electronically transmitted to our "remote" editor at NRL for editing and publishing. All issues since *ESNIB 92-04* have been produced in this manner.

For several years, ONR Europe has also been electronically disseminating important and timely R&D information. More recently, our liaison scientists and scientific officers have been developing larger "mailing" lists for electronic newsletters to a broad range of individual users to provide timely dissemination of information about rapidly changing events. This approach also expedites the organization of focused technological assessments to and by highly specialized scientists.

This is the final issue of *ESNIB*. ONR Europe will continue to keep the R&D community informed by using the electronic newsletters. For further information, contact this office.

The critical role of ONR Europe in disseminating information can be significantly augmented by feedback from you, our readers and ultimate users. Therefore, comments to me about your use of this information, and any benefits, actions, or activities that could enhance the mission of your organization are valuable.

We here at ONR Europe look forward to the new challenges that this electronic future will bring us.

John Silva

Accession For	
NTIS	<input checked="" type="checkbox"/>
CRA&I	<input type="checkbox"/>
DTIC	<input type="checkbox"/>
TAB	<input type="checkbox"/>
Unannounced	<input type="checkbox"/>
Justification	<input type="checkbox"/>
By _____	
Distribution / _____	
Availability Codes	
Dist	Avail and/or Special
A-1	

# Computer Science

## The ONR Data Visualization Workshop

*by Lawrence J. Rosenblum, Liaison Scientist for Computer Science at the Office of Naval Research European Office. He is on leave from the Naval Research Laboratory, Washington, D.C.*

**KEYWORDS:** fluid flow; volume visualization; perception; user interface; large data sets

### INTRODUCTION

The fundamental importance of scientific visualization for understanding both empirical and simulated data sets across disciplines that span science and engineering topics of Navy interest has become acknowledged (and even embraced) over the last half-decade. To assess current progress and research issues for this field, I organized and chaired a workshop that brought together 30 colleagues from around the world who were leaders in specific areas of scientific visualization. This report presents preliminary results from the workshop. The ONR Advisory Panel assembled for the workshop is continuing to develop these themes, and the final results will appear in professional publications (see the section on "Anticipated Products from the ONR Advisory Panel").

In October 1992, I began assembling an Advisory Panel on the topic of scientific visualization. The goal was twofold:

- To facilitate, per the ONR European Office mission, liaison, communication, and discussions of research issues and progress among scientists on both sides of the Atlantic.
- To assess, for specific topics of interest, the progress that the field has made in the six years since it was given its name in the National Science Foundation (NSF) Panel Report "Visualization in Scientific Computing", and, most

importantly, to define today's research requirements and issues for these topics.

By January, the panel was largely in place. The intent was to accomplish preliminaries (including the writing of papers and organizing round table discussions) for holding a workshop in July 1993 and incorporating the workshop's results for professional publications. The panel primarily contained recognized leaders in the field, as well as a sprinkling of young researchers and heads of visualization centers. Geographically, the panel contained 16 members from Western Europe, 10 from the U.S., and 4 from Russia and the Far East.

The workshop was held at the Fraunhofer Institute for Computer Graphics (FhG-IGD) in Darmstadt, Federal Republic of Germany (FRG) in July 1993. The nearly 50 Fraunhofer Institutes in the FRG are well known as high-end technology transfer organizations (i.e., with a strong research component) across a variety of scientific specialties. Special thanks goes to Prof. Jose Encarnacao, Director of FhG-IGD, for hosting the workshop (and serving as a panel member).

The workshop contained three interleaving segments:

- paper presentations by all attendees,
- round table discussions from the members of each working subgroup with participation from other attendees, and

- working time to develop a preliminary statement of research issues for each subgroup.

The workshop's success owes much to the preparation of the panelists (as seen in the outstanding papers presented and discussions held) and to their willingness to concentrate on producing the preliminary statements of research requirements.

The results presented here are those developed at the workshop, including the day following the close when topic leaders (and some others) stayed over in Darmstadt to help produce a statement of research needs. These have been edited into the statement of Research Issues presented here. The results given in this report are PRELIMINARY (and should be treated as such).

**ANTICIPATED PRODUCTS FROM THE ONR ADVISORY PANEL**

The ONR Advisory Panel is continuing to further develop both workshop products—the papers presented by attendees and the definition of research issues—into final products that will appear in professional publications.

We project two major products:

- Workshop papers are being extended and revised by the authors into papers that survey their specialty areas, present (in some cases) current research results, and examine requirements for these highly specialized subareas. These will appear in:

*Data Visualization: Research Issues, Applications, and Future Directions* (tentative title), Academic Press Ltd., ISBN 0-12-227742-2; expected publication, Summer 1994.

- The panel was divided into six working groups at the workshop: Volume Visualization, Vector and Tensor Field Visualization, Perception and User Interface, Modeling Complexity, Foundations and Systems, and Visualizing and Modeling

Large Data Sets. Papers covering the research issues for each working group will appear in:

*IEEE Computer Graphics and Applications*, Special Section on Research Issues in Scientific Visualization; expected publication, Spring 1994.

**RESEARCH ISSUES IN VECTOR AND TENSOR FIELD VISUALIZATION**

Research Issue	Time Frame (years)	Priority
Fill in spaces in visualization tensor	5	High
Comparison of multivariate datasets	5	High
Evaluation	0-5	Medium

**Feature Visualization**

The traditional visualization pipeline consists of several stages: data generation, data preparation, visualization mapping, and rendering. It can be augmented with appropriate loops allowing for interaction and feedback. For feature-based visualization, this model consists of the following stages:

1. definition of features,
2. extraction of features,
3. encoding of features,
4. display of features (icons), and
5. interaction and feedback to each stage of the process.

A taxonomy of possible vector and tensor field visualization techniques is multidimensional with the following axes:

- order of the data: scalar, vector, tensor
- stage of the visualization process

- dimensionality: 2D, 3D, 4D, higher dimensional; includes spatial and temporal dimensions
- locality: point (absolute data value at one point), local (a point with gradient values), intermediate, global (whole area).

Existing visualization techniques for vector and tensor fields can be represented in the taxonomy, and empty spaces are identified. The needs and potentials of these empty spaces are evaluated and should be filled where needed in the next 5 years.

#### Comparison of Multivariate Data

Comparison of multivariate data sets from different sources is an important but little

investigated problem. An obvious need is the validation of numerical simulation models by comparison of numerically generated and measured data. Possible approaches include development of common high-level representations (such as feature-based representations), and metrics and visualizations for comparing these data. Initial results in this area are urgently needed and should become available in the next 3 to 5 years.

#### Evaluation of Visualization Techniques

Important aspects are correctness (error measure), usefulness and effectiveness in generating insight and knowledge, and visualization of tolerance and uncertainty.

#### RESEARCH ISSUES IN VOLUME VISUALIZATION

Topic	Promising Approach	Time Frame (years)	Priority
Volume Rendering Equation	Yes	3-5	High
Transform Coding	Maybe	5-10	High
Enriching Volumes	Yes	3-5	High
Irregular Grids	Maybe	3-5	High
Parallelism	Yes	1-2	Medium
Visual Steering	Yes	1-2	Medium
Custom Hardware	Yes	5-10	High

## Introduction

Volume visualization is a method of extracting meaningful information from volumetric datasets through the use of interactive graphics and imaging. It is concerned with the representation, manipulation, and rendering of volumetric datasets. Its objective is to provide mechanisms for peering inside volumetric datasets and for probing into voluminous and complex structures and dynamics.

### *The Volume Rendering Equation*

Volume rendering is the mapping of the essential content of volumetric scalar data fields onto an intensity field for display. The model is adapted from transport theory, describing the process of movement of light particles through the data field. However, there is nothing particularly physical about viewing volumetric scalar fields (which do not correspond to light emission of physical objects). Visualizing data simply requires well-defined mappings of the parameters of the equation onto meaningful visual quantities.

### *Transform Coding of Volume Data*

Currently, most volume rendering algorithms work directly on the scalar data field to be visualized. Various acceleration techniques have taken advantage of local coherence by representing the data in a pyramidal fashion or as octrees. Other compression techniques may reduce the storage overhead for volume data and allow direct rendering from the compressed data set. Research is needed into the use of transform coding, such as a representation of the data set in a wavelet basis.

### *Enriching Volumes With Knowledge*

Volume visualization is steadily improving in rendering speed and picture quality. However, the semantics of pictures is not part of current models, leaving image interpretation to the user. For many applications, a connection of symbolic and spatial knowledge would be

desirable. One first approach is the "intelligent volume." Research issues include:

- What are optimal data structures for visual knowledge?;
- What must "visual query languages" look like?;
- To what extent are AI and/or DB approaches applicable?

### *Irregular Grids*

Research on irregular grids is still in its infancy. Most existing volume rendering algorithms require data sets with rectilinear grids, allowing at best nonuniform spacing along one or more axes. New methods are needed. An overall strategy could be to interpolate the curvilinear grid into a hierarchical rectilinear grid to support interactive speeds, while supporting either a slower curved ray casting or a slower ray casting with face intersection and trilinear interpolation.

### *Real-time Rendering and Parallelism*

Many applications require real-time volume rendering. Currently these resources are available only on parallel hardware, ranging from multiprocessor workstations to computers with hundreds or thousands of processors. Since communication costs are high and will remain so relative to processor speeds, careful design of algorithms is required to take advantage of the available floating point resources. Initial work has concentrated on regular volume data and has yielded algorithms with multiple frames-per-second update rates supporting very general rendering options. The challenge is to design rendering algorithms that deliver these speeds for irregular grids.

### *Visual Steering*

Real-time visualization, interactive exploration of the data content, and steering of the data evaluation process are the major goals in the development of future volume rendering



tools. In the future, the generated image or animation sequence will be the smallest amount of data to be transferred through high-band networks to the user. Visualizations of the essential data content will appear in a video window on the user's graphic workstation to control the computation itself, the parallel running data analysis algorithms, and to adjust the visualization parameters as viewing point and isosurface threshold. Attempts in this direction have been made to steer simulations of the complex spatial-temporal behavior of 3D cellular automata and nonstationary 3D fluid dynamics (combustion processes, weather forecast).

### *Special-purpose Hardware*

Contemporary graphics accelerators (e.g., SGI, HP) as well as special-purpose machines (e.g., Pixel-Planes, Princeton Engine) have been used for volume rendering, with reasonable performance gain over software implementations. An obvious way to accelerate volume rendering is to build special-purpose hardware for this task. Several attempts have been launched; however, none have gained market acceptance.

The development of true three-dimensional displays are long-term, ongoing research topics. When available, they will revolutionize the way we view and interact with volumetric data. However, developments are progressing at a very slow pace. Texas Instruments has recently announced a preproduction prototype of such a display.

## **RESEARCH ISSUES IN PERCEPTION AND USER INTERFACE**

### **Automated Design of Visualizations**

Visualization is the process of transforming information into a visual form, enabling users to perceive the information. The presentation could include auditory, tactile, and haptic components. More perception research pertaining to the use of computer-based

displays is required. Examples are the use of the perceptual sensitivity to dynamic change and its applicability in data visualization and the interaction between the visual and aural perceptions. Research with implementation in visualization systems could take 10 years.

### **Create New Visualization and Interaction Techniques Based On Knowledge of Perception and Understanding Processes**

Humans perceive information by using visual, auditory, tactile, and haptic cues. Understanding how humans perceive information by using these cues separately and together could help us conceive, design, and develop new effective visualization methods. The relationship between visualization and perception/understanding is bidirectional and can, in turn, also help us better understand perception and cognition processes.

### **Understand Tradeoffs of Making Effective Visualizations**

Different task levels (e.g., interactive real-time exploration, accurate representation of phenomena, and polished public presentation) can require different approaches. Each approach implies tradeoffs between properties such as interactivity, rendering quality, data size, and algorithm accuracy. How do we make these tradeoff decisions? Is there a way to automate these decisions? What kind of user control over these tradeoffs do we provide? How does one prioritize these tradeoffs?

A more difficult problem is data management. Terabyte data sets will be commonplace and, unless a new mass storage technology appears, accessing this data may remain a serious bottleneck in interactive systems. Accessing these files randomly at interactive rates from mass storage is currently impossible, requiring visualization systems to load these data sets into physical memory. Systems for automated generation of visualizations should specify the purpose of the visualization being designed and include knowledge of the optimal tradeoffs for those visualizations.

### **Provide Interactivity for Navigation and Explorations**

Exploration of data sets requires the ability to investigate regions of data, seeking interesting phenomena. The current approach to the quick selection of data is graphical user interfaces (GUIs). A better approach would be automated visualization design where the user specifies a desired goal and the system designs the visualization. Another problem is navigation in large visualization environments. For workstations, this means controlling the camera view. Current techniques use conventional GUIs such as sliders or knobs. Techniques that indicate either the desired direction of travel or the desired destination need to be developed. Examples include choosing objects of interest and automatically maintaining the visibility of those objects.

### **Create Visual Reality Interfaces for Visualization**

Visual reality (VR) interfaces are characterized by inherently 3D displays and input devices providing the user with the experience of being immersed in a 3D computer-generated environment. The effective use of VR interfaces in a visualization environment implies various design opportunities, challenges, and constraints. The opportunities include intuitive exploration environments with directly controlled visualization tools. In the near term, VR-based visualization environments can be built for the investigation of certain problems, e.g. fluid flows, astronomical data, quantum mechanics, and other applications that involve three-dimensional problems and relatively simple computation and rendering. In the longer term, as computation and rendering capability increases and VR interfaces mature, more ambitious systems will be developed. These systems will be based on the experience gained in the simpler systems. Furthermore, multi-user shared distributed VR-based environments will become common. Visualization systems will have to be designed to allow this capability.

### **Apply Usability Methodology to Visualization Systems and Quality Assurance of Presentations**

Usability concerns include functionality as well as how the functionality and results are presented to the user. Developers of graphical user interfaces have successfully used well-developed methodologies, such as in-depth studies of users' needs, observation and video taping (for later analysis) of users performing specific tasks in a usability laboratory, and controlled experiments. Visualization tool developers and users do not typically apply these methodologies to their work. Specific areas of focus would include the traditional matters of command structure, menu and dialog box layout as well as the information presentations, and 3D interaction techniques.

### **RESEARCH ISSUES IN MODELING COMPLEXITY**

**Goal:** Develop tools for automatically segmenting the data into a geometric complex that captures the features of interest for the application at hand and provides a multiview/-multilevel representation suitable for interactive visualization, analysis, and database query.

**Motivation:** An explicit representation of the relevant features and of their interrelations will complement the direct viewing of the "raw" data in many important ways. It will enable efficient interaction with the data, both for human users and for analysis applications.

**Direction:** Intelligent segmentation requires the identification of singularities and of homogeneous regions, whose definitions are application and data dependent. The output of segmentation will feed the construction of a topological model (capturing the adjacency relations between the various elements of the segmentation) and of a series of representations to each topological entity. The approximations will span precise models of the elements' geometries and texture or properties to more abstract representations for queries and rapid interactions.

## Research Issues

### *Primitives*

Applications should be examined to synthesize a list of needed semantic feature types from which segmented models will be composed. For example, a scalar field over 3-space might be viewed as a hyper-surface in 4D or as a series of isosurfaces in 3D. The first representation is easily amenable to the extraction of geometric singularities where topological changes occur between successive isosurfaces. These would be points or curves where the isosurface goes through a local extremum. Then isosurfaces, which contain these singularities, may be constructed as planar cross-sections of the hypersurface and may be used to directly visualize important features of the data. The second representation, although more standard and better suited for efficient graphics, makes it difficult to detect and represent such singularities. Research questions arise: (1) does one need the notion of hypersurfaces and tools for extracting local extreme; and (2) what is the best primitive entity for capturing, say, the trajectories of vortices in a flow field? Should one use parameterized curves in 3D or curves in the 4D space-time domain?

### *Segmentation Algorithms*

Given the characterization of the features of interest, efficient and numerically robust algorithms must be developed for detecting such features and for computing their characteristics. For example, finding all sample points where a scalar field goes through a local minimum would not be sufficient because features between sample points would be missed. Furthermore, the set of points exhibiting a particular characteristic needs to be segmented into (connected) components of a particular dimension.

### *Techniques for Including Domain-dependent Hints*

Segmentation results depend on the characterization of features of interest. Since

these are application- and data-dependent, flexible and general mechanisms are needed to provide different characterizations. Atomic constructs for this characterization must be provided, making sure that they permit an easy expression of the characterization of all the desired types of features for all known applications.

### *Fitting Geometric Descriptions and Approximations*

Once features have been identified and segmented, a precise geometric description of their extent is desirable. A simple example of a geometric fit is an isosurface, which may be represented as a triangular mesh. A precise understanding is needed of how the accuracy of the fit depends on the sampling rate, may be influenced by filtering techniques, and is related to the characterization of the data. This would provide the user with a tolerance for the approximation.

### *Abstract Models of Material and Surface Properties*

In addition to a geometric approximation of the pointset covered by features, one must capture the properties of the data within the pointset. Abstract models are needed for capturing this information in a compact form sufficient for matching models in databases and for reproducing a visually unambiguous rendering of the particular characteristic. Techniques such as mathematical morphology, fractals, and wavelets are potential candidates for such representations.

### *Visual Presentation of Topology*

The segmentation of a 3D space into features (volumes, surfaces, curves, and isolated singular points) has a topology that is important for understanding how the various features relate to each other. Techniques for explicitly visualizing this topological structure in an intuitive manner must be developed.

### *Multilevel Graphics Models*

To support interactive visualization on midrange workstations, level-of-detail models

(i.e., geometric approximations with decreasing accuracy) must be constructed for each geometry.

### *Standard Formats and Automated Queries*

To support data exchange and automated search or fitting, the topological representations, the geometric and abstract descriptions of each feature, must be stored in a standard format or at least accessible through standardized queries in an object-oriented database.

### RESEARCH ISSUES IN FOUNDATIONS AND SYSTEMS

Areas Needing Attention	Time Frame (years)	Priority
<b>Models</b>		
Reference	1-2	High
Data	1-2	High
Time	Results	
Device	5	
<b>Validation</b>		
Test data	1-2	Medium
(+ results)		
metrics	5	Medium
effectiveness		
<b>Systems</b>		
Default parameters	1-5	Medium
Interoperability	5	Medium
Distributed systems	5	Medium
Automation (next generation)	5-10	Medium
Data handling/bases	1-2	Medium
Multimodal interfaces	1-2	Medium
Hard copy	5	Medium

### Key Requirements of a Next-Generation Data Visualization System

- The 3D rendering must make use of specific high-performance graphics hardware wherever available and appropriate. Standard software graphics subsystems like PHIGS and PEXlib cannot be used because they sacrifice performance for standardization.
- Direct interactive manipulation of data must be available, independent of the data size and complexity. The user must be able to explore an area of interest by direct pointing into the 3D data domain.
- Integration of different visualization methods into one image should be provided, for example, arbitrary cutting planes displayed with isosurfaces. The integration will be required not only for spatial dimensions, but also for the time-variant data.
- Semantic interaction with data must be provided to assure data probing in the application data domain as a prerequisite for steering and control systems.
- Context visualization, i.e. displaying geometry from the construction process with the results from applied computing.
- The handling of very large data sets must be supported by intelligent data filters so that only the required data enters the visualization pipeline.
- As visualizing data in real time becomes a realizable goal, modeling of time for transient fields will become part of the methodology.
- Integration of new presentations techniques based on real-time desktop animation, e.g. videocopy.
- Increased need for user-driven visualization environments, which include perception, mental models, and interaction.

---

**RESEARCH ISSUES IN VISUALIZING AND MODELING LARGE DATA SETS**

---

Issue No.	Research Issue	Time Frame (years)	Priority
1	Intersection between DBMS visualization systems and Computational Environment	5-10	Medium
2	Scattered data methods	2-3	High
3	Direct visualization vs modeling, gridding, and visualization	1-2	Medium
4	Data improvement	1-2	Medium
5	Compression of scattered and voxel data	3-5	High
6	Integration of imaging and visualization ("visual computing")	3-5	High
7	Multidimensional Visualization	5+	High
8	Standard terminology for data grids	1-3	Medium
9	Clustering and classification	3-5	High

---

**Description**

1. A tremendous amount of mature technology has been developed in DBMS over the years (relational, enquiry languages, algorithms for very large data sets). Data flow visualization systems have recently emerged, but they only handle very simple data types. Computational Environments (e.g. MATLAB) have lots of numerical analysis tools but usually do not have very good visualization capabilities. There is a need to create tools and algorithms for the development of software systems at the intersection of these three topics.
2. For the most part the research in scattered (irregular) data fitting and modeling, especially in 3D domains, has been done only for small (< 500) data sets. The ideas of "localized" methods might lead to

methods for handling large ( $10^{**6}$  or more) data sets. Least-squares methods (particularly the nonlinear version with variable knot selection) show promise also.

3. This involves the tradeoff in modeling over a curvilinear grid and then evaluating the model function on a Cartesian coordinate set vs extrapolating the data points to a grid directly. The research issue is to select the model so that everything works and to decide when, where, and how well it works for specific applications.
4. This involves how to modify or select data to better extract information. Filtering noise remains an important issue. Structure recognition, testing of features, and constraints are other topics to be considered.

5. Develop techniques to better represent data: octrees, wavelets, etc.
6. Input to scientific visualization and integrate the large body of research in computer vision dealing with large data sets.
7. Scattered data algorithms and other, similar, methods are of central importance for sophisticated visualization systems. Apart from the modeling aspect, quality analysis is a necessary step in this process. CAD/CAM-type tools may offer a solution for testing "quality".
8. This is not really a research topic, but the need for standardizing terminology is clear.
9. Clustering algorithms are very important for data reduction. Representation sets (say, 120,000 points out of 4 million) are the input for scattered data algorithms. These are the standard tools for visualizing large data sets. Classification is important to "highlight" regions of special interest.

#### **APPLICATIONS—A STATEMENT OF NEEDS**

This section discusses the requirements of the scientist/engineer end user. This is only a partial "needs list" and emphasizes the needs of the empirical scientist over those of the computational scientist:

##### **Simultaneous Display of Instruments, Measurements, and Models**

Create unique views of instrument, measurement, and modeling data. Provide the ability to register and simultaneously display both types of data on the same screen.

##### **Animation of Physical Processes**

Create unique animations of physical processes using instrument, measurement, and modeling data. Provide the ability to "synchronize" and simultaneously display repre-

sentations of each type of data on the same screen. Provide independent control for the playback speeds of each animation. This idea could be extended to  $n$  sets of each type of data.

##### **Visualize Scientific Concepts**

Provide tools to visualize scientific concepts, and explore the laws of physics by creating virtual objects that obey physical laws with adjustable parameters (e.g., adjust the gravitational constant, mass, charge, initial velocity). Perform "Gedanken" experiments by using a rich set of virtual objects and mathematical/physical tools.

##### **Displaying the "Visualization Pipeline"**

Provide a graphical view of the visualization "pipeline" so that each transformation to the data is visible and parameters are adjustable by the scientist. It is most important that there be no hidden transformations or assumptions. Each assumption and transformation should be displayable as part of the "visual pipeline", and a full set of tools should be available for interrogating the characteristics of each transformation in a standardized way.

##### **Choice of Coordinate Systems**

Provide a complete set of coordinate systems in which all operations, including the visualizations, are performed and in which objects and tools can be manipulated.

##### **Interactive Scientific Collaboration**

Provide the capability to conduct collaborative visualization sessions in which two (or more) persons working on the same data at different locations can "link up" and provide new views of the data for each other and communicate visual results to each other in an efficient fashion.

##### **Data Transformation Toolbox**

Provide transformations of data that operate on the data to create alternate

representations of the data that preserve the information content of the data. Provide quantitative error bounds for the transformed data, based on the error bounds associated with the original data. Provide a general set of standard visualization tools that anyone can easily use, with an interface that is as natural as that of a Macintosh word processor. Provide discipline-specific visualization toolkits that use the paradigms of the specific disciplines. The transformations should be information-preserving.

### **Interactive Visualization Tool Construction**

Provide an interactive capability to create new visualization tools with user-adjustable parameters and metrics. Include metrics that describe the "goodness" or "information accessibility" of a particular visualization frame (or animation sequence).

### **Information-preserving Interpolation Tools**

Provide a complete set of spatial and temporal interpolation tools, with a quantitative indication of any aliasing. The temporal and spatial interpolation tools should be information-preserving and should provide explicit descriptions of the maximum temporal and spatial frequencies preserved by the interpolation. Tools should be easily accessible to the user. These are needed to filter the data prior to interpolation to guarantee help to avoid aliasing the interpolated data. Mechanisms should be provided that automatically warn the user of any possible violation of sampling theory for any step in the "visualization pipeline".

### **Intelligent Data Structures**

Provide data structures that include the ability to incorporate fundamental data critical to the understanding and interpretation of scientific data. The data structures should be "intelligent" in the sense that they could be constructed so that additional information

should be permanently linked to the basic image or data array. This will allow the scientist to interrogate the data itself to discover additional information in a natural way. This includes information about the representation of the data used by the visualization system (including segmentation, topology, critical points, vertex clustering used) at each step of the visualization process. Visualization tools should be constructed so that they work with this additional information. Tools for augmenting and updating this additional information should also be provided, but the original information should be preserved and a history of any modification to the data (including an identifier of the person modifying the data) should be maintained by the system.

### **Multiresolution Data**

Provide the ability to visualize data with vastly different resolutions forming the same data surface or volume.

### **Multiple Data Sets**

Provide the ability to register and view multiple data sets from different sensors, experiments, and models. Include the ability to decide on the opacity/transparency of each point, line, surface, or volume used to represent the data sets.

### **Probing the Data**

Provide the ability to probe all of the data (and the processing) associated with any pixel (or group of pixels) for any representation of the data. Provide independent simultaneous display windows so that both the current data representation and the probed version are simultaneously visible.

### **Machine Vision/Pattern Recognition Toolbox**

Provide a better set of "machine vision/pattern recognition" tools, including edge detection, feature detection, segmentation, etc.

## Classification/Segmentation

Provide the ability to examine segmentation and classification rules along with the ability to apply these rules to scientific data, and visualize and edit the results of these classifications. Provide a good classification toolbox and facilities for adding user-defined classification and segmentation algorithms.

## Creating and Understanding Instruments

Help scientists design new instruments and understand the operation of proposed and existing instruments. Provide an interface to existing CAD/CAM systems so that scientists can visualize the operation of the sensors used to collect their data and the instruments used to process it. Enhance the ability of scientists to communicate their ideas to engineers and technologists to assist in the creation of new scientific instruments and in the improvement of existing instruments. Create unique views of proposed designs and existing instruments that display the limits of instrument operation and provide the ability to position representations of the data next to instrument components. Provide the capability to animate instrument operation and data flow in a synchronous fashion.

## CONCLUSIONS

The field of visualization has prospered over the last half-decade. Commercial products now allow easy generation of visualizations that previously required significant programming efforts. Volume visualizations allow us to view and comprehend phenomena that could not previously be effectively portrayed. Significant strides have been made in 3D vector and tensor field visualizations, with seminal work in using topological methods. We have a far better view of issues in perception and interface technology.

Nonetheless, scientific visualization is a young, emerging field with much remaining to be accomplished. Even those areas just mentioned as successes have significant research issues remaining to meet the needs of scientists and engineers. Other topics (for example, visualizing high-dimensional and/or large data sets, better interface technology such as virtual reality for improved interactivity and perception, and progress toward automated, goal-oriented visualization systems) are in their infancy. Much additional research is needed over the next decade to fulfill the current promise of visual techniques for data understanding.

## APPENDIX

### ONR Data Visualization Workshop Participants

Prof. Pere Brunet  
Univ. Polytechnic Catalunya  
Spain

Mr. Steve Bryson  
NASA/Ames Research  
Center  
USA

Dr. Eric DeJong  
Jet Propulsion Lab  
USA

Dr. Rae Earnshaw  
Univ. of Leeds  
U.K.

Prof. Jose Encarnacao  
FhG-IGD  
Germany

Prof. Steve Feiner  
Columbia Univ.  
USA

Prof. Jim Foley  
Georgia Tech  
USA

Mr. Julian Gallop  
Rutherford Appleton Lab  
U.K.

Dr. Andre Gagalowicz  
INRIA  
France

Dr. Nahum Gershon  
Mitre  
USA

Dr. Michel Grave  
ONERA  
France

Dr. Marcus Gross  
ZGD  
Germany

Dr. Martin Göbel  
FhG-IGD  
Germany

Prof. Hans Hagen  
Univ. of Kaiserslautern  
Germany

Prof. Lambertus Hesselink  
Stanford Univ.  
USA

Prof. Karl-Heinz Hoehne  
Univ. of Hamburg  
Germany

Prof. Arie Kaufman  
SUNY Stony Brook  
USA

Dr. Stanislav Klimenko  
Inst. for High Energy  
Physics  
Russia

Dr. Wolfgang Krueger  
GMD  
Germany



Prof. Toshiyasu Kunii  
Univ. of Aizu  
Japan

Prof. Frits Post  
Univ. of Delft  
Netherlands

Dr. Jarek Rossignac  
IBM Watson Research Lab  
USA

Prof. Daniel Thalmann  
Federal Polytechnic Inst.  
Lausanne  
Switzerland

Prof. Gregory Nielson  
Arizona State Univ.  
USA

Dr. Phil Robertson  
CSIRO  
Australia

Mr. Peter Schroeder  
GMD & Princeton  
Germany & USA

Dr. Jarke van Wijk  
Netherlands Energy Research  
Netherlands

Prof. Miroslav Novak  
Kingston Univ.  
UK

Dr. Larry Rosenblum  
ONR European Office  
USA (U.K.-based)

Prof. Yoshihisa Shinagawa  
Univ. of Tokyo  
Japan

---

## Research Directions in Fluid Flow Visualization

*by Lawrence J. Rosenblum, Liaison Scientist for Computer Science at the Office of Naval Research European Office. Dr. Rosenblum is on leave from the Naval Research Laboratory, Washington, DC.*

**KEYWORDS:** vector field, tensor field, volume rendering, iconic representation, virtual reality

### INTRODUCTION

Because numerous scientific disciplines require understanding liquid or gaseous fluid flow, visualization of these phenomena has emerged as a key scientific visualization research topic. Until recently, little attention has been paid to three-dimensional (3D) flow visualization. This report examines some recent research directions in fluid flow visualization with a focus on European activities.

Global warming ... the space shuttle ... blood flow through the heart ... microscale ocean phenomena ... aircraft and automotive design ... coastal protection against erosion ... these are just a sampling of the numerous topics of critical interest to society that depend on the ability to model liquid or gaseous fluid flow. By using techniques such as finite differences, finite elements, and multidimensional fast Fourier transforms, these computational fluid flow simulations typically require supercomputers or massively parallel processors to perform the necessary calculations.

Such computational physics algorithms produce huge amounts of numbers as output. What hap-

pens next with these numbers? The 2D fluid flow simulations of the previous two decades provided innumerable demonstrations that the standard graphics of the day, contour plots, were inadequate for extracting detailed understanding. Scientists would thumb through stacks of these contour plots, one for each time step in the simulation, trying to comprehend the dynamics. But it just couldn't be done. New computer graphics tools arose to meet the challenge. After data filtering and color coding parameter values at each pixel, animation was used to enhance perceptual understanding. A frame from such an animation graced the cover of the National Science Foundation report "Visualization in Scientific Computing" that gave the field of scientific (or data) visualization its name.

Two-dimensional data visualization techniques incorporated in commercial systems now offer easy access even to the scientist untrained in visualization. The techniques are partially extensible to 3D and are used with rapidly increasing frequency within the scientific community.

An example of this transition can be seen in the work of Dr. Tim David of the University of Leeds.<sup>1</sup> He uses Wavefront Technologies' Data

Visualizer software toolkit to analyze thermally driven fluid flow. He was integrating the visualization process to in-house-developed flow code. As has been seen across many scientific disciplines, the use of volumetric techniques, in this case examining isosurfaces as planar cross-sections of 3D volumes, produces dramatic knowledge benefits for scientists whose previous tools had been contour plots and other 2D tools. Particle flow could also be represented by using "tracers." Dr. David was pleased that he could obtain effective visualizations by using the Data Visualizer with minimal effort on his part. The analysis process illustrates the progress made toward good desktop visualization over the past five years. A half-decade ago, generating these displays would have required man-years of programming effort.

However, Dr. David's research at the present time on blood flow through the heart also shows the limitations of current desktop technology. He noted that for this application the desktop displays discussed above were not adequate. Three-dimensional, time-varying displays are needed. Recent advances in supercomputer and workstation power have led to an ever-increasing number of these 3D simulations. The third dimension significantly increases the difficulty of data visualization. The development both of new 3D algorithms that make little sense in 2D and of extensions of 2D techniques to 3D have become a "hot topic" that assists in the understanding of the world around and within us.

A recent addition to this 2D work has been the development of an interesting technique called "spot noise."<sup>2</sup> Spot noise is based on the repeated addition of randomly positioned spots on a surface. A stochastic texture is thus produced. The properties of the texture can be varied by changing the properties of the spot, such as shape, size, and direction. If these properties are changed as a function of the data, then structure appears in the texture that contains useful information about the flow.

### THREE-DIMENSIONAL FLUID FLOW VISUALIZATION TECHNIQUES

Fluid flows can be characterized by different types of curves. A particle path is the path traced

out by a single, infinitesimally small fluid element. A streak line arises when particles are continuously inserted in a flow from a single fixed position over a period of time. A streamline is the integral curve of the instantaneous velocity vector field passing through a given point resulting curve is everywhere tangent to the flow direction. All of these provide important clues about the underlying physics. These curves all coincide for steady, time-independent flows, but they can be very different in unsteady, time-dependent flows. The stream surface extends the streamline concept. Just as a single particle traces out a curve, a base curve (consisting of an infinite number of particles) traces out a surface in the flow as time varies. When a large number of streamlines is required to gain understanding, stream surfaces offer better insight into the structure of the flow field. Hidden surface elimination and shading provide depth and orientation cues.

A common technique in fluid flow visualization is the insertion of particles into the flow. A variety of techniques follow: the particle's time-dependent position can be animated, stream lines or stream surfaces can be generated, etc. Each technique helps illuminate different characteristics of the flow field and the selection of technique(s) is problem-specific. Older particle-rendering methods have generally treated the particle as a point. Advantages accrue if the particle is treated as consisting of a very small facet, with an associated surface normal.<sup>3</sup> Because of the facet's small size, the shape is irrelevant but knowledge of the normal assists in the visualization process, by allowing light reflection calculations. A dense cloud of these particles can then have surface-like properties. Stream surfaces can be simulated by using these "surface-particles," generated by user-defined particle sources that have geometric and time-related attributes.

The user interface allows for both continuous and discrete release of the surface-particles into the flow. The rendering pipeline is taken to be shading, transformation, filtering, and scan conversion. The aim is to achieve good quality at a reasonable cost. The latest additions to this work are modified Gaussian filters for the prevention of spatial and temporal artifacts and a new method for computing and compensating for the surface-particle's opacity.

The generation of isosurfaces is a useful technique for examining the interface between regions with different properties, especially when transparency is used to enable the viewing of several isosurfaces at once. By using these methods on numerically simulated data, two British researchers have developed a series of effective animations that evaluate the best fluids for the recovery of oil from a reservoir when injecting fluid to displace the oil from minute pores within the rock matrix. The animation of isosurfaces of water, solvent, and oil helps determine how to best maximize the recovery process.

Volume rendering is a 3D display method that does not depend on constructing the surface of an object. Accordingly, it is valuable for seeing inside an object or displaying nebulous objects such as clouds. These properties make volume rendering a natural choice for examining flow fields. However, volume rendering is most suitable for visualizing scalar data. Thus, velocity (a vector) cannot be displayed directly. Accordingly, scalar quantities are associated with the vector data (e.g., pressure, temperature) or derived from velocity (e.g., speed, velocity magnitude). By associating opacity with the scalar value (e.g., pressure) for each cell, all of space is transparent unless occluded by a parameter of interest with high opacity value. Volume rendering can also be combined with surface rendering methods for flow visualization. One application of hybrid rendering<sup>5</sup> realizes the dispersion of a pollutant in the North Sea. The pollution data, a scalar field, results from a numerical simulation of the pollutant's dispersion by tidal water flows. This scalar field is visualized as a semi-transparent cloud. The bottom topography is from measured North Sea bathymetric data that is visualized as a triangular polygon mesh. A hybrid rendering technique combines the volume ray casting with line and polygon scan conversion and depth buffering.

Data probing methods designed specifically for 3D fluid flow analysis help the scientist extract information about specific regions in a flow field. The 3D probing is straightforward; however, a glyph (a geometrical object with information encoded in the geometry or associated attributes such as color) is used to encode information about parameter values at the data point. The glyph's components are derived by a decomposition of the

velocity gradient tensor, calculated in a local coordinate frame, where one axis is aligned with velocity direction. This results in quantities such as the curvature of the stream line through the probe point, convergence, shear, and helicity (rotation component). Each of these quantities is associated with a specific part of the glyph.

For specific flow phenomena, specialized techniques for analysis and visualization are developed. An example is turbulent flow, where statistical methods are used to model the random fluid motions. For visualization, a turbulent motion effect can be obtained by using particle animation. A perturbation is added to the smooth convective motion, resulting in erratic "random walk" motions. This perturbation is based on numerical data produced by the turbulence model, and directly reflects the random dynamics of the turbulent motions.

An important branch of the current work in fluid flow visualization is based on topological considerations. The topology of a vector field consists of critical points where the velocity vector is zero and integral curves and surfaces connect these critical points. Vector field topology images show the topological characteristics of the field without too much redundant information. The positions of the critical points are found by searching the cells in the flow field. Once identified, they are classified by examining the eigenvalues of the partial derivatives of the velocity. The topological information then becomes the input to computer graphics rendering algorithms to examine the flow field.<sup>6</sup>

## TENSOR FIELDS

Thusfar, this article has examined the portrayal of scalar and vector fields for fluid flow by using "standard" graphical output. Here we look briefly at two of the more interesting extensions of this work: tensor fields and the use of virtual reality.

The visualization methods for scalar and vector fields also have extensions to tensor fields.<sup>7</sup> This research is an extension of the topological analysis of vector fields by Helman and Hesselink to tensor fields. A concept called a hyperstreamline is defined. Hyperstreamlines form a continuous representation of the tensor information along a 3D path. The concept is first derived for symmetric

tensor fields and then extended to unsymmetric tensor data. The hyperstreamline continuously represents both the amplitude and directional information and thus shows much of the physics of complex processes.

## VIRTUAL REALITY

Another interesting extension lies in the use of virtual reality (VR). An open research question is "what gains result when a user is immersed within a data set (with appropriate interactive tools), as opposed to seeing it on a screen?". The "Virtual Wind Tunnel" research at the NASA/Ames Research Center is examining this question for fluid flow around objects.<sup>8</sup> The system uses a VPL Dataglove that incorporates a Polhemus magnetic tracker. The Dataglove's primary use is to provide a gestural interface that permits the user to place rakes of seed points into the flow field. Visualization is achieved by using a Fake Space Labs boom-mounted display that supports two small CRTs on a counterweight yoke attached through six joints to a base. Although few expect the boom to be a long-term winner in the VR display sweepstakes, it offers advantages today over the popular head-mounted displays. The most important of these is that real CRTs can be used for the display (instead of the lower resolution, dimmer LCDs of current head-mounted displays) because the user does not bear the weight.

## RESEARCH ISSUES

The above is representative of recent progress in fluid flow visualization research. Significant strides have been achieved but much research remains. Some of these issues apply directly to fluid flow visualization; others are more generic. A sampling of current problems and research topics:

- *Feature Visualization.* By identifying and visualizing features in a flow, the need for generating and/or visualizing large amounts of data can be reduced. Examples of feature visualization would include critical points and their local configurations, spatial decompositions such as eddies in a turbulent flow, and vortex layers. Work on feature extraction and visualization has begun, but extensions are needed. These methods can also

yield extensions from vector field analysis to tensor field analysis.

- *Occlusion.* In 2D we examine planar flow. Three-dimensional fluid flow visualization requires observing phenomena that may be occluded by other phenomena. Techniques include the use of transparency, reflections and shadows, rotations, and glyph-like information encoding. Nonetheless, the problem of occlusion remains with us and indicates why no single technique suffices. Additional techniques and combinations of methods are still awaiting discovery.

- *Glyphs and Probes.* Glyphs are geometrical objects with encoded properties attached. Perhaps the best known example is the (ONR-sponsored) Chernoff faces. Certainly, it is possible to portray particles with associated parameters by using such characteristics as shape, color, transparency, and other geometrical attributes. In essence, the dimensionality of the number of parameters examined is raised. The Power Probe described above is a recent innovation for probing into a fluid flow with glyph-like representations. The Probe has been used to examine data at points, but there are clearly benefits to extending the probe concept to regions. The exploration of such methods in fluid flow analysis are just beginning.

- *Automation—a Paradigm.* First one visualizes. Then, after visualization methods become commonplace and enhance understanding, one seeks to automate. This can take the form of automatic selection of algorithms and techniques or can be the automatic extraction of numbers that quantify a process. The time for seeking automation in fluid flow visualization may be approaching. The automatic tracking of phenomena within a complex flow field would have many useful applications.

- *Interactive Techniques.* Many techniques for fluid flow are passive. The scientist passively examines a picture or animation, although typically some interactive capabilities such as color look-up table modification are used. The Power Probe and the Virtual Wind Tunnel are two examples of adding greater interactivity to the analysis process. Can these methods be extended? What other interactive methods might assist the scientific process?

There have only been a few explorations of the role of virtual reality for scientific data analysis. Although promise has been demonstrated, its benefits are unproven.

- *Comparison of Empirical and Simulated Data Sets.* One would like to validate simulations by comparing simulated and measured data. This is done currently by viewing single pictures or animations side-by-side. Tools are needed to perform overlays, statistical comparisons, and other qualitative and quantitative measures. Digital imaging/machine vision methods can be used to develop metrics that distinguish the degree of similarity. Feature extraction offers additional means of comparison. This problem merits more attention than it has received to date.

- *Sound.* Glyphs were one possible method of raising the number of parameters that can be explored in a fluid flow simulation. Sound is another. To date, research into the use of sound as a "visualization" technique has failed to provide convincing examples. Still, one suspects that audio is a potentially useful tool. Additional research and, especially, data analysis experiments are needed.

- *Perception.* Animation has been established as a useful tool for understanding fluid flow processes. There is limited understanding of how well we really perceive information from animations. In particular, what information do we fail to see?

- *Implementation.* Although not a research topic, the problem of getting new techniques "out into the field" is very real. When scientific research problems are visualization-limited, we cannot afford to wait the better part of a decade for known techniques to appear in commonly used commercial packages. Interdisciplinary teams are needed and thought must be given as to how to encourage such efforts.

#### ACKNOWLEDGEMENTS

My European colleagues have been very gracious about showing me their latest research and I extend my appreciation. For the work discussed in this article special thanks go to Prof. Frits Post of

Delft Technological University (the Netherlands) and Dr. Jarke van Wijk of the Netherlands Energy Research Foundation (ECN). Portions of this article appeared in Ref. 9, and readers are referred to the color figures therein that illustrate some of the concepts discussed in this article.

#### REFERENCES

1. T. David, "Turnkey Visualization in Computational Fluid Dynamics," Proc. Animation and Scientific Visualization, British Computer Society, Dec. 1992 (to appear in *Animation and Scientific Visualization*, Academic Press).
2. J.J. van Wijk, "Spot Noise," *Computer Graphics* 25(4), 309-318 (1991).
3. J.J. van Wijk, "Rendering Surface Particles," Proc. Visualization '92, IEEE Computer Society Press, 1992, p. 54-61.
4. J.J. Barley and D.W. Williams, "Modelling and Visualization of 3D Miscible Viscous Fingering," Proc. Animation and Scientific Visualization Conference, British Computer Society, Dec. 1992 (to appear in *Animation and Scientific Visualization*, Academic Press).
5. F. Post and T. van Walsum, "Fluid Flow Visualization," in *Focus on Scientific Visualization*, H. Hagen, K. Mueller, and G. Nielson, eds. (Springer Verlag, 1993), pp. 1-40.
6. J. Helman and L. Hesselink, "Surface Representations of Two- and Three-Dimensional Fluid Flow Topology", Proc. Visualization 90, IEEE Computer Society Press, Los Alamitos, CA, Oct. 1990.
7. T. Delmarcelle and L. Hesselink, "Visualizing Second Order Tensor Fields with Hyperstreamlines," *IEEE CG&A* 13(6), 25-33 (19-93).
8. S. Bryson and C. Levitt, "The Virtual Wind Tunnel," *IEEE CG&A* 12(4), 25-34 (1992).
9. L. Rosenblum and F. Post, "Visualizing Fluid Flow," *Computer* 26(6), 98-100 (1993).

# Electronics

## The Electronics Research and Development Landscape in the Former German Democratic Republic

*by Nicholas Bottka, Liaison Scientist for Electronics at the Office of Naval Research European Office. Dr. Bottka is on leave from the Naval Research Laboratory, Washington, D.C.*

**KEYWORDS:** unification; Fraunhofer Society; Max-Planck Society; restructuring; National Research Laboratories

### INTRODUCTION

This report deals with the current electronics research and development (R&D) scene in the former German Democratic Republic (GDR). The information is based on two trips by the author to this former East Bloc country, one in November 1992 to Berlin and the second in November 1993. The author visited universities and research laboratories and had extensive discussions with R&D planners, researchers, professors, and students. The first part briefly describes the reorganization of scientific research and education in the GDR and how these changes are affecting the new R&D scene in the united Germany. The second part focuses on R&D in electronics in the new states of Sachsen and Sachsen-Anhalt.

### THE GERMAN UNIFICATION

The formal unification of East and West Germany on 3 October 1990 was an historic event for the German people and for the world. It brought together two countries that had been ideologically separated for almost four decades and unleashed political and social turmoil that is still being felt today.

The unification heralded major changes in the former East Germany and affected all segments of its society. Among the many entrenched establishments, the learned societies were the first institutions listed for reform under the new German

unification treaty. Article 38 of this treaty set into motion two immediate events:

- the evaluation of German Democratic Republic academic and research institutions, and
- their restructuring into the West German institutional mold.

The first scientific institutions slated for reform in the GDR were those in the Academy of Sciences. They were simply dissolved and their components allocated among various research laboratories with new names.

Next slated for reform were the universities. Unlike the federally funded and controlled research institutes, the universities in Germany are financially supported and governed by the "länder" or states. Because new states had to be "re-created" in the East, reorganization of the educational establishments was much slower and more difficult.

Reorganization of the scientific research and academic community had some drastic consequences. At least half of the scientific staff from the former Academies and many politically appointed university professors lost their positions or were retired. Many of these scientists are part of the older generation who have spent most of their lives under communism and are experiencing difficulties in adapting to the new system.

Be this as it may, the West German scientists partaking in this assessment and restructuring were

fair in the treatment of their East German colleagues. Today, senior professors who were privileged under the old communist regime continue to enjoy financial security under the generous German pension plan.

### **SCIENCE AND TECHNOLOGY REORGANIZATION**

The Federal Ministry for Research and Technology was tasked to bring about this restructuring. The Ministry delegated the particulars of this transformation to the West German Science Advisory Council, whose normal task is to periodically review the West German educational system. Two other West German learned societies were assigned to help in this process:

- the Max-Planck Society, traditionally the focus for basic research in Germany, and
- the Fraunhofer Society, West Germany's association of institutes performing applied scientific research.

The task was complex since practically all scientific research in the former East Germany, both basic and applied, was done outside of the universities. The issue was to sort out which element belonged to the research institutes and which to the universities.

The Max-Planck Society at first was reluctant to take part in this process. It claimed that most of the science done at the GDR Academy of Sciences was applied research. Consequently, the Fraunhofer Society was seen to be the most appropriate institution to become actively involved in restructuring East German science. Only very late in the discussion on unification did the Max-Planck Society agree to support setting up "hard science" working groups at East German universities as part of bringing scientific research back to these educational institutions. Today these working groups are located at universities but are not under university jurisdiction. They are fully supported by the Max-Planck Society, with probationary status. It is expected that in five years these groups will become Max-Planck Institutes or institutes of a university. Only two new Max-Planck institutes in the East were sponsored as full-fledged members of this exclusive fraternity.

### **IMPACT ON THE FORMER SCIENTIFIC ESTABLISHMENT**

The Science Advisory Council set up nine working groups to evaluate different scientific disciplines in East Germany. Representatives for these working units were chosen from academia and the research societies. The former GDR Academy institutes were reformed first. Their fate was decided by the middle of 1991. Restructuring the universities took longer, but by end of 1992 most of them were evaluated and Council recommendations rendered.

The principal verdict and subsequent implementation was the reduction in staff. It was decided that all East German Academy and university institutions were overstaffed. With only a small increase in Germany's research budget, in a country now 25% larger, it was felt that it would be difficult to support science in East Germany in its old style.

The impact of this personnel reduction was enormous. Most of the "old guard" were laid off or went into retirement. Key positions such as department heads at newly established institutes and universities were advertised and filled either with qualified East Germans or with "new blood" from the West. The younger talented members of the former GDR scientific community were either retained by the universities, hired by the newly established institutes, or joined faculties in the West.

### **THE UNIVERSITY DILEMMA**

From the beginning, there has been conflict between the principle of self-government at the university and the resulting ramifications of the GDR's entrance into the FRG system of laws. A case in point was the Humboldt University in East Berlin. Here, the freely elected rector (prior to unification) was an outspoken advocate of the university's right to self-reform. The rector's policies led to direct confrontation with the Berlin Senate. From the start the Senate wanted to have full control in hiring and firing professors and in setting new education policies. It wanted to abolish the five (formerly) politically controlled fields: law, economics, history, philosophy, and education. They were to be transformed into three areas in the

social and political sciences with appointees hired by open advertising of positions. Although the Berlin Supreme Court ruled against such a "meddling" by the Senate into university affairs, the issue is still in dispute.

In 1992 it was my opinion that, with time, the universities would conform to the new political realities of the land; that they would restructure and reorganize in order to survive. The transition may be unpleasant, but the lure of undisturbed scientific research, coupled with the prospect of world recognition of such effort, is a strong incentive to try.

### THE NEW RESEARCH ESTABLISHMENT

Research establishments in East Germany were restructured in the West German format and comprise the following categories (see the Appendix for those that are conducting research in solid state physics and electronics):

- *National Research Laboratories*

These are federally funded establishments doing "big science". Among these, only one can be said to involve research in solid state physics or electronics.

- *"Blue-List" Institutes*

These are funded 50-50% by the federal and state government. Eight Blue-List institutes in the East are doing research in solid state physics and/or electronics.

- *Fraunhofer Institutes*

Two classes were established:

- "Fraunhofer Establishments," which hope to become full-fledged institutes, and
- "Fraunhofer Branch Laboratories," which are branches of existing institutes in the West.

Only one in each of the two categories is doing electronics-related research.

- *Max-Planck Institutes*

One of the two full-fledged institutes, and three out of the 25 Working Groups are pursuing research in solid state physics.

### THREE YEARS LATER

#### Visit to Sachsen and Sachsen-Anhalt

Before unification, the territory now known as Sachsen-Anhalt was one of the largest industrial sectors in the German Democratic Republic (GDR). It was the location for open-pit mining (brown coal) and energy generation and the center for some of the largest chemical industries in the Eastern Bloc. It was also the site for major environmental pollution.

Most of these factories are now closed and silent. They have become industrial relics, symbols of the scarring of the land and its people, the legacy of 40 years of communist rule. The newly formed state is trying to recover from this physical and psychological abuse. The healing process is slow and painful. Sachsen-Anhalt has one of the largest unemployment rates in the FRG, almost 20%. Many young workers have moved to the Western sector in search of jobs and a new life.

In spite of this bleak scenario, the overall atmosphere in this central German region is teeming with optimism and hope. Everywhere one looks there is construction. Highways, roads, streets are being repaired; new rail and telephone lines are being installed; old buildings are restored and new shopping centers are mushrooming. In contrast to a year or two ago when the population seemed to be in a catatonic trance, people today are more confident and smiling. Service in stores and restaurants is polite and efficient. There is a "can do" feeling.

### THE ELECTRONICS R&D SCENE

Before 1990, the GDR was a major contributor to electronics technology within the Eastern Bloc. The electronics R&D centers were located at Berlin, Erfurt, Freiberg, Leipzig, and Dresden. Most of this R&D was done at the GDR Academy of



Sciences, industrial laboratories, and to a minor extent, at the universities. Berlin was the hub for processing of microcircuits; it also was the center for optoelectronics, e.g., semiconductor lasers. Freiberg was (and still is) the site for crystal growth (Si, GaAs, InP, and GaP). There were three major facilities for developing and processing computer microchips at Erfurt; most computer assembly took place at Robotron, in Sommerda near Erfurt. R&D in HgCdTe and related compounds was done at laboratories in Berlin, Leipzig, and Dresden. The Humboldt University in Berlin had a very active physics program in the growth and characterization of II-VI materials. Of course, during the communist regime, Western contact with these facilities was not encouraged.

Today, most of these R&D sites have either been taken over by West German firms, have been completely restructured, or have simply been shut down. For example, Wacker-Chemitronic, the pioneer of GaAs and one of the world's leading manufacturers of GaAs wafers, transferred its GaAs production facilities from West Germany to Freiberg Electronic Materials (Freiberger Elektronikwerkstoffe, FEW), a new GaAs production complex located in Freiberg/Sachsen. Most of the electronics R&D that was formerly done at the GDR Academy of Sciences is now performed at so-called "Blue-List" research laboratories or at newly established Fraunhofer institutes. The most notable are the Paul-Drude Institute for Solid State Electronics in Berlin, Institute for Semiconductor Physics in Frankfurt (Oder), Ferdinand-Braun Institute for High Frequency Communication Technology and Optoelectronics in Berlin, and the Fraunhofer Institute for Microelectronic Circuits and Systems in Dresden. The newly formed Max-Planck Institute of Microstructure Physics in Halle plays a supportive role within the German electronics R&D community. The following is an activities update at some of these institutions.

#### **MAX-PLANCK INSTITUTE OF MICROSTRUCTURE PHYSICS**

This old and renowned institute in Halle, formerly called the Institute of Solid State Physics and Electron Microscopy, is the crown jewel of the newly established Max-Planck institutes in East Germany (and the only one in physics). The re-

search objective of this facility is the study of solid state phenomena at surfaces and interfaces in small dimensional structures. Scientists are trying to elucidate the relationship between the microstructure of solids and their mechanical, optical, electrical, and magnetic properties. Single and multilayered magnetic and nonmagnetic materials are grown and studied in ultra-high vacuum environments. The structural and chemical properties of these materials are investigated by electron, photon, and ion probes.

The specific projects reflect the interests of the three institute directors:

- Professor J. Heydenreich is the only remaining member of the leading "old guard." (Professor Heinrich Bethge, founder and director of the former GDR institute, has retired). Heydenreich's research interests include high-resolution electron microscopy (HREM), scanning tunneling microscopy (STM), scanning electron microscopy (SEM), and related electron probe measuring techniques such as cathodoluminescence (CL) and electron beam induced current (EBIC). The institute has pioneered the development of a new commercial instrument called scanning deep-level transient spectroscopy (SDLTS). DLTS is a well-established method of investigating deep-level defects in semiconductors. The new scanning DLTS combines the local excitation of an SEM with DLTS to get a lateral image of the deep-level distribution with spatial resolution found in SEM. This new Halle instrument has combined SDLTS, SEM, CL, and EBIC capability and (as of this month) can be purchased on the open market from Raith GmbH in Dortmund.
- Professor U.M. Goesele is one of the two "newcomers" to the institute. He is originally from Duke University (U.S.) and is pursuing fundamental studies of "wafer bonding" between solid state systems. One of the many uses of this atomic bonding method is the integration of silicon wafers (microelectronic) with other important material systems such as GaAs, quartz, and ceramics for potential application in flat panel displays and integrated opto-electronics.

- Professor J. Kirschner is the second new member of this troika. He comes from the Free University of Berlin, and his research focuses on the magnetic properties of thin metal films, specially the correlation between structural/growth and magnetic/electronic properties. One of the projects involves utilization of STM in an ultra-high vacuum to study the early stages of nucleation of Fe on Ni.

## SOLID STATE ELECTRONICS AT LEIPZIG

Two groups at the University of Leipzig are performing electronics-related research. The first one, Semiconductor Physics, is headed by Prof. Kreher. Its research emphasis is on growth of III-V compound semiconductor films by OMVPE (organometallic vapor phase epitaxy) and their characterization by using optical spectroscopies such as ellipsometry, photoluminescence, and photoreflectance. Dr. Gottschalch is in charge of the OMVPE growth; Dr. Rheinlander runs the characterization laboratory. All of the above-mentioned researchers were in Leipzig during the GDR years. The second group, Solid State Physics, is currently waiting for a group leader (most likely someone from the West). Its research focus will be on photonics.

Two noteworthy observations can be made:

- Professor Kreher's group has acquired extensive new instrumentation within the last two years. They are as well-equipped as any research laboratory in the West. This seems to be the norm at most of the universities I visited.
- Dr. Gottschalch was the first East German (if not the first European) to initiate OMVPE-related research in 1971, only three years after Manasevit's pioneering work at Rockwell. The Leipzig group of scientists is very knowledgeable in the art of epitaxial growth using OMVPE since, during the GDR era, they had to develop all aspects of the OMVPE technology themselves. Now, with access to the latest OMVPE technology from the West, Dr. Gottschalch is producing state-of-the-art InGaAs/GaAs material by using their new (West German) Aixtron

reactor. They are able to control and grow reproducibly both phases of GaInP (the random alloy phase and the ordered CuPt structure with alternating monolayers of the group III elements on the {111} planes). The ordering has significant influence on material properties such as band gap and carrier mobility. The control of such phases in InGaAs and AlInGaAs is crucial in the development of green/blue semiconductor lasers.

## OMVPE AT LEIPZIG

Organometallic vapor phase epitaxy (OMVPE) is one of the two leading epitaxial growth techniques used in the fabrication of homo- and hetero-junction semiconductor structures. It has promise in becoming the leading technology in producing (on a large scale) the next generation of high-speed monolithic microwave and millimeter wave integrated circuits (MMICs) and optoelectronics (OEICs). Along with molecular beam epitaxy (MBE), OMVPE has spawned new scientific discoveries and novel device concepts. MMICs and OEICs operating in the gigahertz (GHz) frequency range constitute the backbone of future electronic systems, e.g., telecommunications, mobile satellite and cellular communications, wireless local area network, active phased array radar, and advanced electronic warfare systems. Such high-frequency integrated circuit components also affect the economy. They reduce the cost of existing microwave/millimeter wave systems and offer new electronic market opportunities.

The original concept of OMVPE started at Rockwell International in the late 1960s with the pioneering work of Manasevit. Much of the early R&D in OMVPE was funded by the Navy. The value of this new epitaxial growth concept was immediately noticed by the East German scientists. Dr. Gottschalch was the first East German (if not the first European) to initiate OMVPE-related research as early as 1971. According to Gottschalch, a large team was assigned to develop this important technology for the GDR electronics industry. Their main obstacle over the years was the purity of the starting chemical precursors (a problem that was solved by American and British scientists in the

mid 1980s). All other aspects of OMVPE reactor design were solved by the Leipzig group.

Today, with access to the latest OMVPE technology from the West, Dr. Gottschalch's team is producing state-of-the art III-V semiconductor materials using their new (West German) Aixtron reactor.

Again, the following is worthy of emphasis:

- how quickly the new research ideas conceived in a Western laboratory have been adapted in East Germany, and
- how effective COCOM regulations (such as export control on high purity organometallic precursors imposed by the West) were in suppressing S&T electronics progress in Eastern Bloc countries.

### SOLID STATE PHYSICS AT HALLE

Six separate groups within the Physics Department at the Martin Luther University in Halle are doing solid state physics research. The following lists some of projects.

- *Theoretical Physics*, headed by Prof. P. Rennert: Electronic band structure of semiconductors; surface physics of metals, semiconductors and their alloys; atomic configuration of adsorbates such as S, Se, Ga, and O on GaAs.
- *Experimental Glass Physics*, headed by Prof. G. Berg: Structural and optical properties of metal-cluster in glass systems (for potential filter application); polarization via elliptical precipitates induced by heating of glass under stress; study of ferroelectric phase transitions in barium titanate; nonlinear dynamics and chaos in ferroelectric materials; microhardness studies of glasses and crystals.
- *Experimental Crystal Physics*, headed by Prof. R. Hoeche: X-ray diffraction topography of crystals; material characterization by TEM and STEM (using model VG HB-501 unit).
- *Semiconductor Physics*, headed by Prof. H. Suessmann, a well-respected expert in thermoelectric materials in the former Eastern Bloc: Peltier effect studies; growth and characterization of thermoelectric

semiconductors, e.g., BiTeSb; multilayered structures for more efficient Peltier devices; growth of thermoelectric materials in space. (This group was involved with Soviet Cosmos space experiments).

- *Surface and Interface Physics*, professor chair currently open: Most members of this group are currently working in collaboration with BESY in Berlin doing photoelectron and photoacoustic spectroscopy of metals, oxides, and semiconductors, e.g., Se/GaAs.
- *Solid State Spectroscopy and Microanalysis Group*, currently composed of independent researchers (among them my host, Dr. Schreiber): Research includes X-ray spectroscopy of layered structures, e.g., GaSe; SEM and electron loss spectroscopy from solid surfaces; photoreflectance of semiconductor surfaces, e.g., SiO<sub>2</sub>/GaAs, Si<sub>2</sub>N<sub>3</sub>/GaAs, S, Se, Ga/GaAs; defect characterization using SEM, CL, and EBIC; plastic deformation studies in InP and GaAs. This group interacts strongly with the new Max-Planck institute in Halle.

### SCANNING DLTS AT HALLE

The concept of DLTS measurement of semiconductor wafers is crucial to the improvement of material quality, reproducibility, and yield. These, in turn, are key ingredients for reducing cost and improving competitiveness in the rapidly changing electronics market. The addition of the scanning capability to such a measurement over the whole semiconductor wafer is very important from a production/quality-control point of view.

The original scanning DLTS concept was proposed by Petroff and Lang at Bell Laboratories in the U.S. and has been used by them as a research tool over the past 10 years. The idea was picked up by Breitenstein at Halle, who improved and finally commercialized the instrument under the new stewardship of the Max-Planck Society. Two points are worthy of emphasis:

- how quickly the new research ideas conceived in a Western laboratory are improved and made into an important commercial product, and

- the Max-Planck Society, bastion of fundamental research in Germany, is supportive of and involved in such "applied" ventures.

## ASSESSMENT AND CONCLUSIONS

It is interesting to note that my assessment of the former East German scientific community from one year ago still stands:

*"It is my opinion that, with time, the universities (in East Germany) will conform to the new political (free democratic) realities of the land."*

They have, but the transformation and adaptation has occurred even faster than I expected.

*"They will restructure and reorganize in order to survive."*

They have done both. Some universities and research laboratories have progressed faster than others; the new Max-Planck Institute in Halle has completed this process fully.

*"The transition may be unpleasant, but the lure of undisturbed scientific research, coupled with the prospect of world recognition of such effort, is a strong incentive to try."*

Considering the openness, the hard work, and the "can do" attitude that I have observed throughout my visits in East Germany, the future looks bright for many of the hard-working and talented scientists.

It is also important to reiterate the speed with which important Western ideas and concepts have been brought to fruition in (former) East German laboratories. Case in point is the improvement and commercialization of the scanning DLTS instrument in Halle and the early development of OMVPE technology in Leipzig. These topics need further expansion.

Finally, it is important to add that today, with the new scientific order in Germany, the research institutions in (former) East Germany represent a vital link between the West and the former Eastern

Bloc states. After all, they were an integral part of the former communist block for more than four decades. In the past, East German scientists established strong bonds with their colleagues in Russia through collaborative research projects and scientific exchange programs. These connections are still very strong. As East Germany transitions into a fully integrated democratic Germany, this connectivity will play an important role in bridging the two worlds. Such bridging will bring together not only the scientific communities but will hopefully spill over into all other cultural and social ramifications of life.

I, personally, have no doubt that a region that was the nurturing place for giants like Martin Luther, Johann Wolfgang Goethe, Johann Friedrich Schiller, Johann Sebastian Bach, and Georg Friedrich Handel will re-emerge from the ashes and will again play a leading role in shaping the next millennium. [A complete summary of these institutes (in all scientific disciplines) is found in Hans Dolezalek's ONR Europe Report 93-3-R, "The East German Research Landscape in Transition. Part B: Non-University Institutes."]

## Appendix A

### NEW SOLID STATE PHYSICS AND ELECTRONICS INSTITUTES IN THE FORMER EAST GERMANY

#### NATIONAL RESEARCH LABORATORIES

Hahn-Meitner-Institute, Research Group on Photovoltaics

Rudower Chaussee 5, Haus 12.8

D/O-1199 Berlin-Adlershof

Tel: +49(30)6704-4251

Fax: +49(30)6704-4249

Director: Prof. E. Kast

Objective: Physics and technology of Si-based photovoltaic structures

#### "BLUE-LIST" INSTITUTES

Paul-Drude Institute for Solid State Electronics (Paul-Drude Institut für Festkörperelektronik-PDI) Hausvogtei Platz 5-7

**D/O-1086 Berlin**

Tel: +49(30)20377-352 or -356

Fax: +49(30)238-4528

Director: Prof. Klaus Ploog and Prof. Fred Koch

Objective: Research on mesoscopic structures on III-V semiconductors

**Institute for Solid State Physics and Materials Research**

(Institut für Festkörper- und Werkstoffforschung-IFW)

Helmholtz Strasse 20, PSF 16

D/O-8027 Dresden

Tel: +49(351)4659-380

Fax: +49(351)4659-500

Director (acting): Dr. H. Eschrig

Objectives: Superconductivity and magnetism; thin layers and deposition

processes; solid state chemistry; electrochemistry and conductive polymers; surface and micro analysis; X-ray structural research and chemical analysis

**Institute for Non-Linear Optics and Time-Resolved Spectroscopy**

(Institut für Nichtlineare Optik und Kurtzzeit-spektroskopie-INOK)

Rudower Chaussee 6

D/O-1199 Berlin-Adlershof

Tel: +49(30)6704-2585 or 3951

Fax: +49(30)6704-4494 or -2386

Director (acting): Prof. Witlof Brunner

Objectives: Generation and application of fs-pulses; nonlinear optics and spectroscopy of low dimensional structures (molecules, clusters, mesoscopic semiconductors)

**Institute for Surface Modification Leipzig**

(Institut für Oberflächenmodifizierung Leipzig)

Permoser Strasse 15

D/O-7050 Leipzig

Tel: +49(341)2392-2308

Fax: +49(341)2392-2313

Director: Prof. F. Bigl and Prof. Bethge

Objectives: Application-oriented research regarding interaction of radiation with matter; interaction of low-energy ions with solid state surfaces; ion beam processing with nanometer precision

**Heinrich-Hertz Institute for Communication Technology, Berlin**

(Heinrich-Hertz Institut für Nachrichtentechnik, Berlin)

Working Group on Electroluminescence (Arbeitsgruppe "Elektro-Lumineszenz")

Hausvogtei Platz 5-7

D/O-1086 Berlin

Tel: +49(30)2037-7326

Fax: +49(30)238-4527

Director: unknown

Objectives: Basic materials research on EL-systems; technology of EL displays

**Institute for Crystal Growth**

(Institut für Kristallzuchtung)

Rudower Chaussee 6

D/O-1199 Berlin-Adlershof

Tel: +49(30)6704-2893

Fax: +49(30)6704-5921

Director (acting): Dr. W. Schroeder

Objective: Bulk crystal growth for universities, research institutes, and small industrial establishments

**Institute for Semiconductor Physics**

(Institut für Halbleiterphysik)

Walter-Korsing Strasse 2

D/O-1200 Frankfurt (Oder)

Tel: +49(335)373-0 or -220

Fax: +49(335)326-195

Director (acting): Prof. Herman Georg Grimmeis

Objectives: Device physics (modeling and simulation); microlithography; physics of thin layers; defect studies; wafer processing; device processing technologies: CMOS, SOI; Si-based sensors, CCD, detectors

**Ferdinand-Braun Institute for High Frequency Communication Technology and Optoelectronics**

(Ferdinand-Braun Institut für Hochfrequenztechnik-FBH)

Rudower Chaussee 5

D/O-1199 Berlin-Adlershof

Tel: +49(30)6704-5715

Fax: +49(30)6704-4525

Director (acting): Dr. Grundler

Objectives: Industry-oriented R&amp;D of GaAs electronics and electro-optics; design,

processing, analysis; OMVPE growth of heterostructures; processing of MMICs

## **FRAUNHOFER "INSTITUTES"**

### **Fraunhofer Establishments (Fraunhofer Einrichtungen)**

Fraunhofer Institute for Microelectronic Circuits and Systems, Dresden (Fraunhofer Institut für Mikroelektronische Schaltungen und Systeme, Institutsteil Dresden-IMS-2)

Grenz Strasse 28D/O-8080 Dresden

Tel: +49(51)5823-0 or -111

Fax: +49(51)5823-266

Director: Dr. Kuck (Dresden).

Director of IMS-1 in Duisburg: Dr. G. Zimmer

Objectives: CMOS control systems, applications in telecommunication, medical, and entertainment electronics; control technology for automotive industry; integration of sensors and signal processing on Si chip

### **Fraunhofer Branch Laboratories (Fraunhofer Aussenstellen)**

Fraunhofer Branch Laboratory for Automation of Circuit and System Design (Fraunhofer Aussenstelle für die Automatisierung des Schaltkreis-und System-Entwurfs, Dresden-EAS)

Hackel Strasse 20

D/O-8027 Dresden

Tel: +49(351)463-211

Fax: +49(351)4717-558

Leader: Dr. Elst

Objectives: Development of tools for VLSI and system design; circuit development such as analog/digital ASICs, sensor circuit development; CAD, development of algorithms for enhanced automation of design processes

## **MAX-PLANCK INSTITUTES**

(only one full-fledged)

Max-Planck Institute for Microstructure Physics (Max-Planck Institut für Mikrostrukturphysik)

Postfach 250

Weinberg 2

D/O-4050 Halle (Saale)

Tel: +49(345)601-512

Fax: +49(345)271-55

Board of Directors: Professors H.

Fischmeister (acting), U.M. Gosele, J.

Heydenreich, J. Kirschner, and M. Rühle

Objectives: Image structure and properties of nano-scale structures; electron microscopy of micro- and nano-structures; theory of nanoelectronics; study of solid state reactions in micro- and nanometer range; crystal defects: electrical and mechanical properties; compound interface properties

### **Max-Planck Working Groups**

Theory of Low-dimensional Semiconductor Structures

(Theorie dimensions-reduzierter Halbleiter an der Humboldt Universität)

Hausvogtei Platz 5-7

D/O-1086 Berlin

Tel: +49(30)2037-7512

Fax: +49(30)2612-035

Head: Dr. Robert Zimmermann

Partnership Institute: Max-Planck Institut für Festkörperforschung, Stuttgart

Objectives: Optical properties of excitons; theory of highly excited semiconductors (electron-hole plasma); theory of low-dimensional semiconductors

X-Ray Diffraction of Laminar Systems

(Röntgenbeugung an Schichtsystemen an der Humboldt Universität Berlin)

Hausvogtei Platz 5-7

D/O-1086 Berlin

Tel: +49(30)2037-7441

Fax: +49(30)2612-035

Head: Dr. Rolf Kohler

Partnership Institute: Max-Planck Institut für Festkörperforschung, Stuttgart

Objective: X-ray studies of epitaxial layers

Theory of Complex and Correlated Electron Systems (Theorie komplexer und

korrelierter Elektronen-systeme an der TU Dresden)

Helmholtz Strasse 28

D/O-8027 Dresden

Tel: +49(351)4659-380

Fax: +49(351)4659-500

Head: Dr. Helmut Eschrig

Partnership Institute: Fritz-Haber Institut der  
Max-Planck Gesellschaft, Berlin

Objective: Theory of local effects of the  
electron correlation in high- temperature  
superconductors, magnetic systems, and  
metal-semiconductor transitions

**PRIVATE INSTITUTES** ("Fully funded by  
government")

Technical Institute Jena  
(Physikalisch-Technisches Institut Jena)

Helmholtz Strasse 4

D/O-6900 Jena

Tel: +49(3641)23-72 or -406

Fax: +49(3641)23-406

Head: Dr. H.G. Zach

Objectives: Materials research;  
superconductors; nonlinear optical; optical  
fibers and fiber sensors; thermosensors;  
optical coatings; thin film technology

---

## Environment

### Environmental Dimensions of Europe: An Assessment

*by Michael Overcash, former Liaison Scientist for Chemical Engineering and the Environment at the Office of Naval Research European Office. He is a Professor of Chemical Engineering at North Carolina State University.*

**KEYWORDS:** research funding mechanisms; Commission of the European Communities; clean technology; U.S.-European collaboration; environmental regulations;

#### INTRODUCTION

The breadth of topics included under environmental improvement is very wide in Europe; this characteristic is also shared with other developed nations. Separate threads of information from extensive discussions, available written material, and the evaluation of future planning documents on specific environmental issues can be assembled to provide an overall environmental fabric characteristic of Europe. Distinctions and comparisons are important in interpreting European issues, in relation to those of other advanced nations. Countries often share new concepts or attempt to emulate each other on such very public issues as the environment.

Observations contained in this assessment, particularly built on research and technical issues,

are difficult in the environmental field. So many of the activities are driven by nontechnical perceptions, rapid changes in "hot" issues, and very heavy political dimensions. Thus observations must be placed in context. It is clear that the underlying political structure of Europe is different from other advanced countries (such as the United States, Japan, Canada). Europe has only modest public debate, making legislation somewhat easier. There is a general empathy for social programs, that is, broad services available to all (with corresponding taxation requirements). Different attitudes toward government and significantly different cultural frameworks also influence environmental requirements. For environmental issues, which depend so heavily on such nontechnical dimensions, the transfer of environmental policy and particular emphases is at best a difficult

activity. Opportunity for direct exchange of approaches between Europe and the U.S. is rare.

This paper is constructed to provide a view of general issues that emerge from a characterization of European environmental research, development, and policy. Several concepts are thus put forward as observations. Assessments have been derived from numerous involvements with engineers, scientists, and government personnel responsible for environmental research and development (R&D) in Europe. Principally the countries and governments of the United Kingdom (U.K.), the Federal Republic of Germany (FRG), The Netherlands, Switzerland, Italy, and the Commission of the European Communities are the focus for this assessment. The difficulty of providing an integrative view remains a challenge with so much information gathered from individual scientist, engineers, and organizations. The observations put forward are followed by further discussion and then by some recommendations, if appropriate. Recommendations are to help utilize European environmental concepts in the United States context. Greater detail and explanations have been included in previous *ESNIB* reports<sup>1-4</sup> and in the Chemical Engineering and Environmental Newsletter issued from ONR Europe.

## 1. OBSERVATION

*Research funding mechanisms and objectives of the Commission of the European Communities (CEC) work with increasing effect to bring European engineers and scientists together in collaborative efforts. The consequences for U.S.-European research interaction are significant.*

Individual researchers typically devote a modest amount of time and resources to joint research projects outside their own university or institution. This collaboration is a vital means to not just learn of other efforts, but also to actively participate with researchers having different research approaches, new equipment, or geographic context for study. Additionally, international research interaction creates subtle synergistic effects that are positive for the progress of nations.

The CEC mechanism for research funding in engineering and science requires that individuals

form multicountry teams within the CEC. This process is escalating rapidly. Research budgets of individual countries are being reduced and emphasis is being given to obtaining CEC support. Competition is high (e.g., out of 680 proposals in Area II.2 of the Environment Program, only about 40 will be funded). The process of identifying partners and exchanging information has long-term benefits, even if a particular proposal is not funded. It is often heard, "I (a German researcher) would never have known about research (in Italy) without this funding process, and the research is of good quality!" Unsaid is that before 1990 the external research most familiar to individual Europeans was in the U.S. Now, since only limited time is typically devoted to collaborative research efforts, the consequence has been to look more within Europe than without.

This is illustrated with marine scientists in the U.K. (Plymouth Laboratory, Southampton University, British Museum, etc). Collaboration with researchers in the U.S. in the 1980s was highly sought after. Conference attendance and exchange of scientists were common. With the advent of European efforts such as the North Sea project, COST 647 (Coastal Benthic Ecology), CEC Marine Science and Technology (MAST) funding, etc., U.K. marine scientists now work with European colleagues. Their collaboration is generally with institutes such as Station Biologique (Roscoff, France), Centre for Advanced Studies (Blanes, Spain), Netherlands Institute of Ecology, etc.

Another facet of the current circumstances regarding U.S.-European collaboration is that U.S. scientists are often constrained when such international efforts are proposed. Travel and clear commitment to multi-country R&D efforts are difficult. This is not likely to change. However, the effective awareness of research plans, newly initiated work, and participating scientists is vital to leading-edge research efforts in the U.S. Awareness on the part of individuals, organizations, and government agencies is essential to enhance contacts that are or will be at the front edge of research. Therefore, consideration should be given to separating the issues and difficulties of research collaboration at the level of detailed projects from the critical flow of information about research agency funding and directions. The former is difficult to change at present. The latter



is manageable and involves a network of European agencies and principal investigators with some mechanism for periodic assessment. That is, with reduction in widespread one-on-one interaction, there is a great opportunity for periodic determination of research commitments and directions to assure reasonable feedback. It would be several years before such information would reach publication and hence direct periodic assessment is considerably more valuable.

### Recommendation

Develop mechanisms to annually summarize activities (detailed research listings, not just budget areas) of leading European government funding agencies in environmental research. Provide this to a network of U.S. agencies and researchers to assure awareness of the most current and potentially future directions in specific environmental research areas.

## 2. OBSERVATION

*There is a high level of European government funding to industry for improved market position in environmental technology for regulatory compliance. Pollution control is viewed as a significant business sector and is encouraged directly through R&D. As environmental regulations continue to evolve, a strong European focus is on technology for pollution control.*

This is a form of push-pull development in which continuous improvement is sought for environmental management of emission to all media. From monitoring, design, equipment manufacture, etc., the technology and products are continually emerging. The business of manufacturing or providing services is evolving—not just for European markets, but for world-wide use.

The environmental R&D necessary to achieve continual improvement and competitive development is directly supported by European governments. The goals are to lower the cost of environmental compliance in their own country. Since current European levels of pollution control

are generally modest and for many medium and small firms may be uncommon, future capital requirements are large to achieve the goals for environmental compliance. Hence there are national incentives to develop more cost-effective and better performance in pollution control. This stimulates government funding to develop and produce better environmental technology. The issue of direct government/industry efforts on environmental solutions is not controversial, even when business advantages are the result. It is anticipated that pollution control technology will propagate and be readily available at lower costs, hence government objectives to fund such development.

This atmosphere is stimulating in such countries as the FRG, The Netherlands, and Switzerland. The achievements of technology transfer are significant; business potential often exists and markets are created by environmental regulations. This is illustrated by the German Federal Ministry for Research and Development (BMFT). More than 75 percent of all industry R&D projects funded for the environment have subsequently been used by other firms outside those involved in the original development. This program is the order of \$180 million per year, including pollution control and pollution prevention. Many industrial sectors are targeted, including some mature industry such as leather and tanning, as well as those with more technology changes (aerospace). Applications for this pollution control business capacity is also aimed at the potential in formerly East Europe. In this sense, the environmental sector is consistent with European commitment to and leadership in the manufacture of equipment for manufacturing and other applications.

### Recommendation

It is not clear that direct significant changes in joint U.S. government/industry development for competitive position in pollution control technology business are likely. However, studies for improved understanding of how such collaboration works in Europe at a large scale might provide another perspective for decision-makers to improve U.S. policy.

### 3. OBSERVATION

*The interface of environment and manufacturing to yield clean technology for industry has generated very significant improvement in competitiveness. European governments have provided substantial funding to joint industry projects for environmental improvement. The benefits to manufacturing improvement have been advantages from advanced technology to enhance world-wide competitive position, particularly for medium and small firms.*

Clean technology has as an overarching justification that the environment is improved through less emissions from manufacturing. However, when strictly applied, clean technology refers primarily to manufacturing process changes that are cost-effective and reduce potential losses to the environment. In this context, the major improvements of cleaner technology (pollution prevention) are on manufacturing competitiveness through continuous process improvement. This of course has significant potential for entire business sectors in a nation's economy. European governments have made very substantial investments in cleaner technology for improved industrial competitiveness, but with the primary justification being environmental improvement.

As an illustration, one cleaner technology program of The Netherlands is Eco-design (about \$1.2 million). Eight manufacturing sectors are receiving R&D support to not just improve manufacturing, but to examine the entire design of products for cost-effective improvements. The environmental consequences of current design and production provide a new framework to reexamine the design. Usually many potential changes are identified and reexamined in-depth, but generally few are finally selected for change. These usually have two major business improvements. One is more cost-effective production, often by design selection, with less materials or chemicals thus improving profitability. Another is that the product is designated a special environmental improvement (green product) and can then be selected by consumers or other industries seeking to purchase better products. This facet can represent significant long-term market benefits for Dutch industry.

Funding for cleaner technology R&D in Europe often follows certain procedures. Two to three manufacturers, and often a university or institute, are funded to develop a process improvement that prevents pollution. Direct work by all parties is a common format based on respective expertise. This work can span efforts from basic research through field trials. The manufacturing and business developed then fosters pressure to utilize improvements and hence promotes effective technology transfer. The not-invented-here syndrome is reduced. When cleaner technology projects are funded in large quantity, the debate over preferential treatment is lessened; multiple technologies are often supported in the same industry. The very significant reduction of risk where manufacturing change is concerned is important. This is particularly true since the added societal benefit for the environment is perceived to occur also. The magnitude of such cleaner manufacturing and hence improved competitiveness in the FRG is about \$20-25 million per year. Medium-sized companies are most often funded, but not exclusively, because they are perceived as capable of rapid change and are encouraged to export, i.e., to establish a competitive world position.

#### Recommendation

Consideration should be given to the European model of R&D funding for cleaner manufacturing (pollution prevention). This means direct support of industry teams with university involvement (and more shared work load), which leads to potential process improvement or new technology. This would be between current U.S. support, using such formats as CRADA (Cooperative Research and Development Agreement, essentially one company) and large consortia (often university centers) with only overall industrial input in the R&D direction. It appears worthwhile to test such a new model based on the success achieved in Europe.

### 4. OBSERVATION

*European environmental basic and applied research has a strong focus on the larger issues facing government and industry. Focus*

*has thus provided a context for diverse approaches and enhances the likelihood of technology transfer of successful results.*

Environmental issues involve technology and policy in a blend that must then help define how best to utilize public funds to achieve improvements. Public funds are often invested in R&D. In several European countries the technology/policy process has led to establishment of environmental priorities (not always the same for each country). An across-the-board, attack-every-environmental issue, is not considered effective. Instead European governments appear to emphasize making rapid, significant progress on priority issues. The R&D community then is provided with diverse opportunities to work within these priorities. The government objectives are to assure greater fundamental understanding, steady improvement, and lower costs for environmental priorities established for each country.

As an illustration, chlorofluorocarbons (CFCs) are a world and European priority environmental issue. When it became clear that no direct substitute for the myriad of CFC applications would emerge, a different and important challenge arose. Given hundreds of CFC uses, how could each be studied in a rational way and alternative developments made to allow continued manufacturing or consumer products that formerly depended on CFCs. This is a priority for the German Federal Ministry for Research and Technology (BMFT). Their emphasis is less on development of new chemicals, presumably because many researchers are active in this area. Instead, this program is focused on the very important R&D needed to actually make existing replacements work. They currently support about 30 projects in this field, grouped as:

- refrigerants and heat exchange,
- alternative electronic assembly,
- glass and metal cleaning,
- polyurethane and polystyrene foams, and
- textile finishing.

The goals are to actually improve the a manufacturing process so that the CFC substitute also creates greater competitiveness. Priorities in Europe tend to be smaller in number than the U.S.

Current examples include plastics, CFCs, soil remediation, cleaner technologies, and wastewater treatment and recycling.

Research and development efforts are diverse in these topics and include good basic studies, engineering research, and directed industrial development. The involvement of teams is characteristic, including multi-university groups, industry/university efforts, and multi-industry consortia. Usually these teams address one special part of a larger problem. Funding, integrated over years or multiple environmental problems, can be substantial. For example, many university professors can support research groups of 30-50, comprising Ph.D. candidates, post-doctoral individuals, technicians, and undergraduate researchers. This exists because of the strong R&D commitment by government and industry in such places as the U.K., FRG, The Netherlands, Switzerland, Belgium, and Denmark.

#### **Recommendation**

No direct course of action is recommended—only that one understands better the R&D context of European engineers and scientists:

#### **5. OBSERVATION**

*The relationship between European regulation and complete, broad compliance is not direct and may be characterized as the difference between what is said and what is done.*

Political processes for establishing environmental regulations in Europe are firmly ingrained in governments and the perceived public attitude on the environment. Regulations have been set within countries and through international accord. Standards, quantitative values for achievement, generally are set very rigorously, i.e., with a high degree of environmental control. The ability of individuals in society, government operations, or industry to meet these standards is not such an imperative. Thus what is accepted practice often means adopting some reasonable improvements, but not obliging strict compliance.

As an illustration, soil remediation targets in The Netherlands (the A-List values) are clearly

tough, highly clean concentrations representing a strict environmental policy. Except in the simplest site cases, there are no technologies in the economic realm that can achieve these levels. Thus, what is done is to apply reasonable remediation technology with steady R&D improvements, thereby achieving cleanup but not to the standards. However, when discussed, the standards are always used to characterize the Dutch commitment and regulation in soil remediation. In this case, standards were clearly set before sound understanding of technology, processes, or risk.

This illustration is repeated in a number of environmental areas in European countries. Their situation is not highly legalistic. Limitations in meeting regulations are also reasonably open in professional circles and conferences. This difference between what is said and what is done also serves as a framework for readiness to sign rigorous international accords (such as at the World Environment Conference at Rio de Janeiro, Brazil). Additionally, the contrast between actions and goals also exists for CEC regulations and country compliance.

### Recommendation

It is critical that when transfer of policy or regulatory concepts is made from Europe to the U.S. or elsewhere, that greater attention be given to understanding the actual level of environmental achievement than the apparent regulatory standards. Differences clearly exist and must be included to rationalize performance among international programs.

## 6. OBSERVATION

*The defense departments of European countries have environmental responsibilities and goals, but these tend to be achieved or directed as part of the entire government structure rather than as a separate organization.*

In the overall structure of government, European departments of defense often have substantial environmental obligations. Site remediation is a very obvious example. Large areas of significant contamination exist at military facilities in many European countries.

For example, Stadtallendorf, FRG, was the largest explosives manufacturing site in Europe. The high amounts of explosives (about 125,000 mt of TNT) produced, unsuitable reclamation processes, and explosive destruction of parts of the production facilities, as well as removal of production residues have resulted in wide-spread soil contamination. This site has been studied for about 5 years, and more than 21 landfill sites have been discovered. Investigations have reduced the actual contaminated area to around 150 acres (from an original estimate of 1,040 acres). While studies continue, the complexity of cleanup is just now beginning to be understood. No foreseeable strategy is emerging that meets cleanup goals and economic targets.

The strategy for site remediation or environmental compliance is to consider the defense establishment as just another government facility. Resources for compliance are a broad government responsibility, with regulatory agencies and operating departments governed as a part of the overall government structure. Thus environmental compliance comes in an obvious way from the over-all government budget and is clearly judged on both regulations and affordability. While strong differences can occur between departments over environmental matters, these are generally resolved within the elected party government structure.

### Recommendation

No clear recommendation or course of action is required. The unified concept in European governments of environmental responsibilities must be understood, both as regulatory and as public stewards of the budget.

## 7. OBSERVATION

*Debates on affordability and public fiscal support for the environment are emerging in European countries.*

For a variety of reasons, the implications of environmental policies on the economy are becoming clearer and potentially will influence future directions. It is hard, if not impossible, to define a

major sharp turn on environmental issues in European public perceptions. Most people still hold positive goals for a better environment. However, numerous smaller reactions may signal a maturing attitude that could influence political and technical discussions.

I questioned many scientists involved with life-cycle analysis and multi-industry assessments. None could identify broad changes in products or processes that were more costly, better for the environment, and widely accepted by the public. Thus, while changes that are better for the environment are and should be aggressively sought, the latitude to achieve change where economics are significantly influenced appears narrow.

Government representatives, remediation specialists, and scientists openly talk of the pressing need to change soil remediation goals. The number of sites, the costs of ultraclean soils, and the ability to pay have continued to argue for more realistic goals and risk assessment.

Asda, the fourth largest U.K. supermarket chain, has recently abandoned the bulk of all green detergents. Other products such as grey recycled pulp diapers are no longer viable to consumers. These changes, combined with a consumer feeling of unfair high prices for ecoproducts, have made green consumerism a very narrow niche.

Migros, the Swiss supermarket chain, has continued to offer ecoproducts at competitive prices. However, the market potential of such an approach has failed to attract virtually any other Swiss firm to adopt a similar approach.

This process of continual evaluation and decision-making is vital in democratic societies. Current concerns with environmental benefits versus costs have occurred principally where feedback has allowed decision-makers (government and consumers) to see the relationship of costs for proposed actions and expected results. The ability to quantify larger cascading effects of individual decisions have also catalyzed this debate.

### Recommendation

Subtle phenomena are occurring as answers on what to do next in the environmental area become more complex. This is not a retrenchment, but a new perspective for future decision-making. Linear projections of envi-

ronmental regulatory influences derived from public debate and support may thus be premature in estimating a future course of environmental action.

### CONCLUSIONS

Europe continues to be an important environmental laboratory for generating different ideas and research directions. At any time, such environmental activity is influenced by external economic factors, just as in the U.S. and Japan. Their particular regulations pose some unique requirements on the U.S. organizations present in Europe. An attempt to summarize some of the environmental scene, and in a sense to compare to the U.S., has been made in this assessment. Predictions of the future remain difficult and thus pose economic uncertainty for decision-makers in industry and local government. It is clear that continual sophisticated review of European activities will discover concepts that could have significant long-term impact on the U.S., while other concepts found will prove to be less relevant.

### REFERENCES

1. M. Overcash, "Cleaner Technologies Concept for U.K. River Basins May Impact Harbor Programs," *ESINIB 92-08*, 522-523 (1992).
2. M. Overcash, "Methodologies for Determining Clean Technology Alternatives - European Research and Development," *ESNIB 93-05*, 289-305 (1993).
3. M. Overcash, "European Countries Commit to Cleaner Manufacturing," *ESNIB 93-08*, 499-513 (1993).
4. M. Overcash, "European Soil Remediation Research," *ONR Europe Report 93-9-R* (1993).

### CONTACT

Dr. Michael Overcash  
Pollution Prevention Research Center  
Chemical Engineering Department  
Box 7905  
North Carolina State University  
Raleigh, NC 27695-7905  
Tel: (919) 515-7385  
Fax: (919) 515-3465

# The Structure of Frontal Weather Systems in Western Europe

by Peter V. Hobbs, Professor of Atmospheric Sciences, and Director of the Cloud and Aerosol Research Group, University of Washington, Seattle. During 1992-93 he was Visiting Professor at the Instituto Fisbat, CNR, Bologna, Italy, and at the Institute of Physics of the Atmosphere, University of Mainz, Germany.

**KEYWORDS:** frontogenesis; dropsondes; vertical profiles; cyclones; thermodynamics

## BACKGROUND

It is not surprising that the maritime and seafaring nations of Western Europe have long been interested in storm warnings and forecasting. After all, it was stormy weather that finished off the "Invincible" (Spanish) Armada in 1588.

During the second half of the nineteenth century, synoptic weather charts began to be used in Europe (and the United States) to depict current weather conditions and the movement of storm systems. The Dutch meteorologist Buys Ballot used such charts starting in 1852, and by 1859 he was issuing official government weather reports and forecasts. In England, a small network of weather-observing stations was organized by James Glaisher in 1848. In this same year, meteorological reports from the network appeared in the *Daily News* for two months. In 1854, Admiral Robert FitzRoy (earlier, captain of the famous *Beagle* voyage), was appointed head of the British Meteorological Department (forerunner of the British Meteorological Office, BMO). In 1861, FitzRoy began to issue daily weather forecasts in the *Times* newspaper, and he set up a system of storm warnings for ships.

In 1854, the British-French fleet, engaged in the Crimean War, was destroyed by a storm in the Black Sea. Subsequent studies by the French indicated that the storm had been in the Mediterranean Sea on the previous day, and might therefore have been predicted. This led to the organization of a storm-warning system in France (1855) and daily weather charts depicting pressure distributions and winds that extended out over the Atlantic Ocean.

The implications and importance of meteorology for military operations became very apparent in World War I. Mechanization of warfare,

the introduction of aircraft and airships, long-range artillery bombardments, and the use of poisonous gases all required knowledge and forecasts of the weather. Prior to the Great War, official meteorological services had not been considered essential to the military. By the end of that war, all three major branches of the military on both the Allied and German sides had their own meteorological weather sections. Many of these survive today, and in some European countries the national meteorological service is still run by the military.

Working in Leipzig during World War I was a Norwegian physicist, turned meteorologist, by the name of Vilhelm Bjerknes. Bjerknes and his colleagues worked on the development of prognostic methods based on thermodynamics and dynamics that were relevant to both meteorology and oceanography. On his return to Norway after the war, Bjerknes founded a geophysical institute in Bergen where, together with his son Jacob Bjerknes, Halvor Solberg, and Tor Bergeron, he began studying the nature of the low-pressure systems (cyclones) that dominate winter weather in Western Europe. In 1919, J. Bjerknes (then aged 22) published an 8-page paper that introduced the concepts of warm, cold, and occluded fronts (note the use of the military term *front*—used in this case to refer to the "battleline" between different air masses) and he explained their relationships to extratropical cyclones and the forecasting of weather.

For the next 75 years the classical Norwegian cyclone model, developed by the Bergen School, provided the conceptual framework for weather forecasting in mid-latitudes. The symbols representing the various types of fronts are now familiar to millions of television viewers worldwide. However, during the past several decades or so, some important modifications and

additions have been made to the Norwegian model of the structure of frontal systems. In the remainder of this article, a brief description is given of some of the new ideas, with emphasis on recent European contributions.

[For more information on the history of weather forecasting in the 19th and 20th centuries, see: *The Thermal Theory of Cyclones: A History of Meteorological Thought in the Nineteenth Century*, by G. Kutzbach (American Meteorological Society, 1979) and *Appropriating the Weather: Vilhelm Bjerknes and the Construction of a Modern Meteorology*, by R. M. Friedman (Cornell University Press, 1989).]

### THE MESOSCALE STRUCTURE OF EXTRATROPICAL CYCLONES

In the Norwegian model of a cyclone, the clouds and precipitation associated with a warm front are depicted as being fairly uniform and produced by the slow, widespread uplifting of the air in the warm sector air as it rides up over denser, colder air ahead of the warm front. Precipitation is viewed as diminishing appreciably, or being absent, in the warm-sector air that follows the passage of the warm front (Fig. 1). At the cold front, the undercutting of the warm-sector air by cold, denser air of polar origin is depicted as producing heavy, convective-type precipitation. Behind the cold front, the weather is pictured as bright with scattered convective showers.

Although the Norwegian model provides an overview of the distribution of precipitation in extratropical cyclones, the actual distribution of precipitation is generally much more complex and is organized on smaller scales. This complexity and organization is revealed by radars, which first

became available to the meteorological community following their development (for aircraft detection) in World War II.

During the late 1960s and 1970s, Dr. Keith Browning and colleagues at the BMO studied the small (meso-) scale structure of cyclones passing over England by using large radars located at the Royal Radar Establishment, Malvern, England. These studies revealed that the precipitation was often organized into elongated bands that were often oriented parallel to the warm and cold fronts. The widths of the rainbands ranged from a few kilometers up to about 50 km. The concept of *conveyor belts*, which transport large quantities of moisture, heat, and momentum within a cyclone, was also found to be useful. For example, a warm conveyor belt from the south flows just ahead of and along the length of the cold front, it then turns anticyclonically (i.e., to the right) as it overtakes and ascends over the cold air ahead of the surface warm front (Fig. 2). Reference 1 is a summary of Browning's early work on this subject.

The tendency for the heaviest precipitation in cyclones to be organized into bands was also found in studies of cyclones over the Pacific Northwest of the U.S.<sup>2</sup> and in Japan.<sup>3</sup> A classification of these rainbands, with respect to frontal structure and satellite imagery, is shown in Fig. 3. From 1976 to 1987 work was carried out in France on the small-scale, three-dimensional structure of fronts.<sup>4</sup>

One of the important outcomes of Browning's work was the development of a weather radar network in the U.K., which is in operational use for weather forecasting. Similar radar networks now exist in other countries in Western Europe. The combined use of these radar networks with satellite

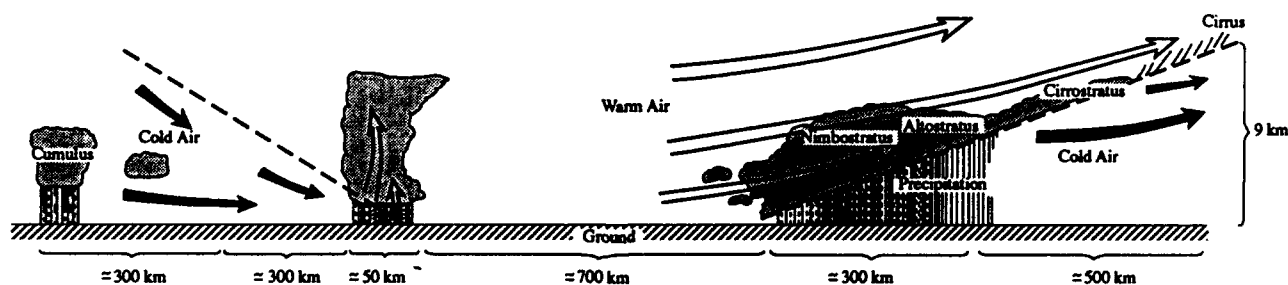
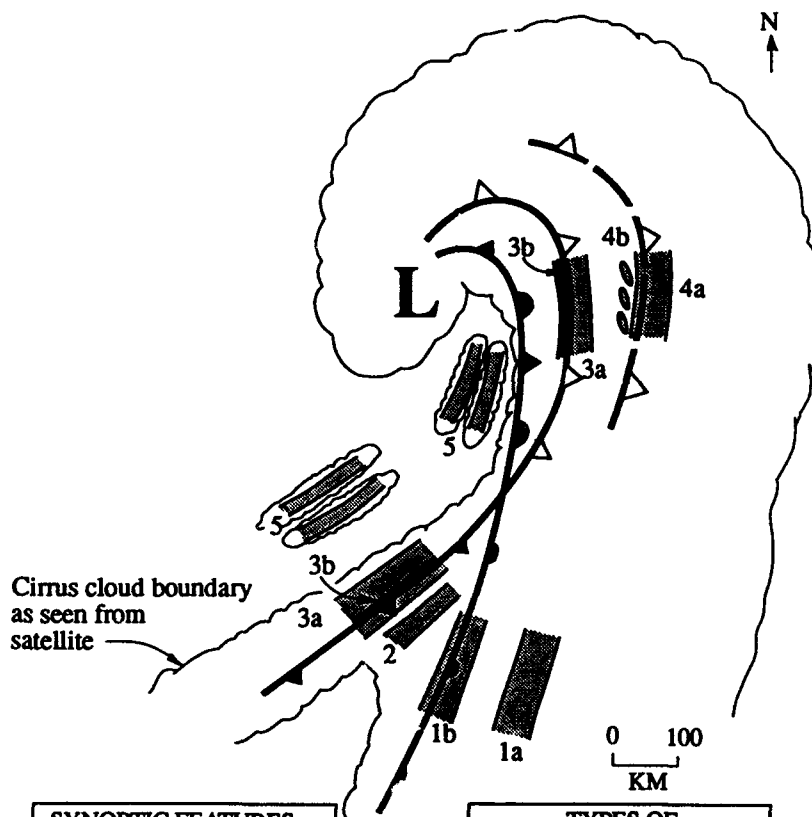
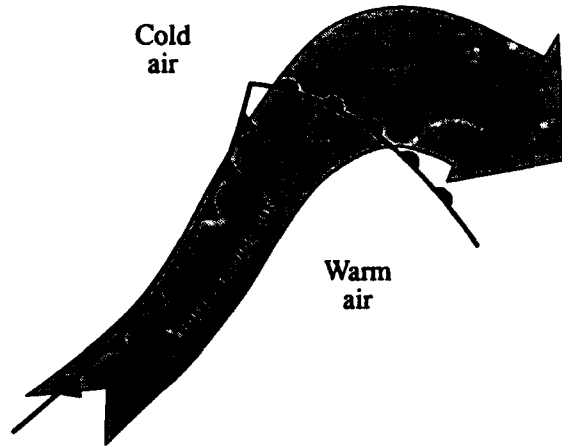

Figure 1 — Vertical cross section through an idealized middle-latitude cyclone, based on the Norwegian cyclone model. Sloping dashed line on the right is the warm front; sloping dashed line on the left is the cold front. Arrows indicate airflow. (Note: the vertical scale is stretched by a factor of about 30 compared to the horizontal scale.)

Figure 2 — Schematic portrayal in plan view of the airflow in an extratropical cyclone in which the warm conveyor belt (solid arrow with stippled shading) is undergoing forward-sloping ascent over a cold front before rising above the cold air ahead of the warm front. (Adapted from Ref. 1)



SYNOPTIC FEATURES	
L	SURFACE LOW PRESSURE CENTER
▲	SURFACE COLD FRONT
▲	SURFACE WARM FRONT
▲	SURFACE WARM OCCLUDED FRONT
▲	COLD FRONT ALOFT
▲	PREFRONTAL COLD SURGE ALOFT

TYPES OF MESOSCALE RAINBANDS	
1.	WARM-FRONTAL
2.	WARM-SECTOR
3a.	WIDE COLD-FRONTAL
3b.	NARROW COLD-FRONTAL
4.	PREFRONTAL COLD SURGE
5.	POSTFRONTAL

Figure 3 — Schematic representation of the types of rainbands (stippled areas) observed in extratropical cyclones (from Ref. 2)



data and high-resolution numerical weather forecasting models has led to significant improvements in nowcasting (i.e., detailed descriptions of current weather) and short-range (0-12 hr) weather forecasts of precipitation.

### THE FRONTS 1987 PROGRAM

As a first step toward developing detailed cooperative scientific studies of frontal systems in Europe, U.K. (the BMO and the University of Reading) and French (Centre de Recherches en Physique de l'Environnement Terrestre et Planetaire, CNET-CNRS and METEO FRANCE, CNRM) researchers carried out a joint field study of cold fronts in 1987 known as the Mesoscale Frontal Dynamics Project (or FRONTS-87). The principal objectives of FRONTS-87 were:<sup>5</sup>

- To obtain improved understanding of the structure, evolution, and interactions on various scales within weather systems containing cold fronts;
- To acquire mesoscale data sets and to use them for the development of conceptual and numerical models of frontal systems; and
- To improve understanding of the basic theory of fronts and frontogenesis and the roles of latent heating (due to cloud formation) and convection.

The theory of frontogenesis that FRONTS 87 was meant to test stemmed from work described in Refs. 6-8 and extended to include latent heating, as described in Ref. 9.

The FRONTS-87 field project was carried out between October 1987 and January 1988. It was centered in the channel between England and France, which is frequented by cold fronts from the Atlantic Ocean. One of the main observational facilities was dropsondes from aircraft, which provided high-resolution measurements of the vertical profiles of temperatures, humidity, pressure, and winds.<sup>10</sup> Another was a dual-Doppler radar pair. (Doppler radars can measure the speed of a target along the direction of the radar beam. If the target is precipitation, which is carried by the wind, such measurements give the component of the wind speed along the radar beam. By using two such

radars to measure the components of the wind speed along two nonparallel lines, the wind velocity can be derived.) Two meteorological research aircraft were used for turbulence and cloud microphysical measurements. The variations of wind velocity with heights were also measured with VHF and UHF radars and sonars.

FRONTS-87 provided detailed data on eight frontal systems. The plan to concentrate on especially active cold fronts was not fully realized, since most of the systems contained multiple fronts with complex regions linking surface and upper fronts.<sup>11</sup> However, analyses of the data sets has tended to concentrate on a few of the case studies where relatively strong fronts passed through the observational network. The FRONTS-87 data sets have also been used to evaluate and advance theoretical concepts related to fronts.

### FUTURE PLANS

Plans are now being formulated to mount a new FRONTS field study in western Europe, to take place in the winter of 1996-97. Earlier called FRONTS-96, this project is currently named FASTEX (Fronts and Atlantic Storm Tracks Experiment). It is expected that in addition to the U.K. and French participants of FRONTS-87, FASTEX will include German, U.S., and Canadian participants.

The focus of the new study will be on frontal-wave cyclones and the related frontal and cyclone cloud systems. Cyclogenesis in the region of fronts is a topic of considerable interest and some controversy. Recent studies indicate that there may be as many as five different categories of frontal-wave cyclones, depending on where they form relative to the parent cyclone. The aim of FASTEX is to document some of these events in detail, including the larger scale environment that leads to the cloud systems and sub-synoptic developments within the North Atlantic storm track zone. Data sets will be collected to meet the following primary objectives:

- To improve understanding of the dynamical and physical processes leading to the development of "end-of-storm track" frontal-wave cyclones;

- To improve understanding of the large-scale diabatic effects of the midlatitude storm-track clouds on the climate system;
- To develop and calibrate future operational observing systems for the North Atlantic; and
- To develop data assimilation procedures and numerical models.

The last two objectives are meant to significantly improve the forecasting of frontal-wave cyclones over the northeast Atlantic and north-western Europe. Several proposed theories focus on the three-dimensional structure of the flow and thermodynamics over cross-frontal dimensions of about 500 km and along-front dimensions of about 800 km. Therefore, the observational strategy will emphasize data collection on these scales. A major effort will also be directed toward the large-scale environments in which the waves form.

The use of several new experimental facilities are planned for FASTEX. The main ones will be dual-beam Doppler radar antennas, built by the French, that are mounted aboard U.S. research aircraft (Electra and P-3) and, possibly, one or more pilotless aircraft ("drones") to release dropsondes from very high levels and upstream of developing cyclones over the Atlantic Ocean. The BMO C-130, and other research aircraft, will also be used. The location of the intense measuring network will probably be to the northwest of Scotland. Other measurements will be made along a line from the Azores to Scotland.

FASTEX is coordinated by a Scientific Steering Group, jointly led by Dr. Alain Joly of MÉTÉO-FRANCE and Prof. Keith Browning of the BMO and the University of Reading's Joint Centre for Mesoscale Meteorology.

## REFERENCES

1. K. A. Browning, "Mesoscale Structure of Rain Systems in the British Isles," *J. Meteor. Soc. Japan* **52**, 324-327 (1974).
2. P. V. Hobbs, "Organization and Structure of Clouds and Precipitation on the Mesoscale and Microscale in Cyclonic Storms," *Rev. Geophys. Space. Phys.* **16**, 741-755 (1978).
3. Y. Nozumi and H. Arakawa, "Post-frontal Rainbands in the Warm Sector of Subtropical

- Cyclones Over the Ocean," *J. Geophys. Res.* **73**, 487-492 (1968).
4. J. Testud, G. Breger, P. Amayenc, M. Chong, B. Nutter, and A. Sauvaget, "A Doppler Radar Observation of a Cold Front: Three-dimensional Air Circulation, Related Precipitation System and Associated Wave-like Motions," *J. Atmos. Sci.* **37**, 78-98 (1980).
5. S. A. Clough, "The Mesoscale Frontal Dynamics Project," *Meteor. Mag.* **116**, 32-42 (1987).
6. R. T. Williams, "Atmospheric Frontogenesis: A Numerical Experiment," *J. Atmos. Sci.* **24**, 627-641 (1967).
7. B. J. Hoskins, "Atmospheric Frontogenesis: Some Solutions," *J. Roy. Meteor. Soc.* **97**, 139-153 (1971).
8. B. J. Hoskins and F. P. Bretherton, "Atmospheric Frontogenesis Models: Mathematical Formulation and Solution," *J. Atmos. Sci.* **29**, 11-37 (1972).
9. A. J. Thorpe and K. A. Emanuel, "Frontogenesis in the Presence of Small Stability to Slantwise Convection," *J. Atmos. Sci.* **42**, 1809-1824 (1985).
10. P. Ryder, A. F. Lewis and D. A. Bennetts, "The NAVAID Dropsonde," *Meteor. Mag.* **112**, 367-380 (1983).
11. S. A. Clough and J. Testud, "The FRONTS-87 Experiment and Mesoscale Frontal Dynamics Project," *WMO Bull.* **37**, 276-281 (1988).

## Contacts

Dr. Alain Joly  
Centre National de Recherches Météorologiques  
MÉTÉO-FRANCE, GMME  
42, av Coriolis  
F-31057 Toulouse cedex  
France

Dr. Keith Browning  
Joint Centre for Mesoscale Meteorology  
Harry Pitt Building  
University of Reading  
Whiteknights Road  
P. O. Box 240  
Reading RG6 2FN, England.

# Materials

## A Process Borrowed From Polymers: Injection Molding of Ceramics at Brunel University, U. K.

*by Mufit Akinc, former Liaison Scientist for Materials Science at the Office of Naval Research European Office. Dr. Akinc is a Professor of Materials Science and Engineering at Iowa State University.*

**KEYWORDS:** injection molding; ceramic processing; Brunel University; ceramic fabrication; polymer processing

*"The nation's eroding competitive position in some industries stems largely from national weakness in materials processing technologies. The essential difficulty seems to be that, with increasing frequency, industries abroad are bringing the results of R&D, or innovative design, to production and thence to the market place in considerably less time than is the present practice in this country."*

Materials Science & Engineering for the 1990s  
National Research Council Report, 1989

### INTRODUCTION

Demand for ceramic parts in high technology applications has doubled in the past five years. The difficulties encountered in mass producing complex ceramic shapes is the major factor in our inability to meet the increasing demand. Several processes, such as pressing, casting, and extrusion, are well-developed for a variety of ceramic formulations. Injection molding lends itself to automated, near-net-shape fabrication of complex parts such as gas turbine parts and turbo charger rotors. Recently, application of this technology to ceramic fabrication has received some attention. At present, ceramic parts with thin sections (< 10 mm) are successfully fabricated by this technique, but manufacture of thick sections has not yet been achieved. Mutsuddy at Batelle Laboratories (U.S.) and Evans at Brunel University (U.K.) are among the pioneer researchers in injection molding of ceramics. This article reviews and assesses the ceramic injection molding research activity at Brunel University.

### BRUNEL UNIVERSITY

Brunel University, located in Uxbridge, west edge of London, is a relatively small university with fewer than 4000 undergraduate and 1000 graduate students. The university was established in 1968, but most of the schools became active in the late seventies and early eighties. In spite of its recent past, Brunel University has established a unique place in the U.K.'s higher education and research scene. The primary focus from its inception has been the science with practice; course programs as well as research programs are closely linked with industry. Most undergraduate students are in so-called "sandwich" programs, which are similar to co-op programs in the U.S. Students in these programs spend half their time (alternating semesters) in industry.

The university strongly emphasizes contracts and collaborative programs with industry, both small and large. To some extent, Brunel University, especially its engineering school, gives the

impression of a training laboratory for industry. In addition, it has several technology centers on the campus grounds. Although they offer a large number of degree programs, information technology, management systems, and materials technology are heavily emphasized.

The Department of Materials Technology of the Faculty of Technology has 17 faculty members who carry out both fundamental and applied research. The research activity is supported by grants and contracts totaling about \$3 million/year, from both government and industry. The Department also has its own research center, the Wolfson Center for Materials Processing.

The department's activity in higher education and research concentrates in three main areas: materials processing, surface sciences, and oxidation and degradation. Materials processing activities include areas like injection molding of polymers, adhesives, metal matrix and ceramic matrix composites, welding, ceramic fabrication, and glass manufacture. The surface engineering program deals with deposition and surface coatings, friction and wear, and structure and properties of grain boundaries. Oxidation and degradation deals with solid/gas interactions, fatigue of welded polymers and metals, fracture mechanics, and corrosion.

The faculty claim that Brunel University, in particular the Materials Technology Department, has the highest employment placement record in the U.K.; they attribute this to a very healthy collaboration with industry.

Professor Evans and his group are involved in ceramic fabrication methods. Fabrication techniques they are studying are primarily the ones commonly used in polymer technology (injection molding, vacuum forming, compression molding, blow molding, etc.). They emphasize injection molding techniques because of potential industrial implications. In the past seven years, they have addressed many aspects of ceramic injection molding. The work has generated more than 75 scientific and technical papers in this area alone. Evans' group is about 14-15 strong, including his colleague Dr. Edirisinghe, 3 post-doctoral researchers, 1 technician; the remainder are graduate students. The funding for the group is about \$500,000/year (this excludes the salaries of permanent staff). The majority of the funding is

derived from SERC (Science and Engineering Research Council) and industry. They also draw on the facilities and capabilities of Wolfson Center.

## INJECTION MOLDING OF CERAMICS

Before discussing recent research activities in injection molding of ceramics at Brunel, characteristics of and issues related to injection molding of ceramics are briefly summarized.

Ceramic injection molding differs from that of unfilled polymers in that the polymer constitutes less than half of the feed by volume, it is a transient component in the fabrication process, and it is removed after the forming stage. Difficulties encountered in fabricating ceramics having thicknesses greater than 10-15 mm are related to defects observed in the forming stages.<sup>1</sup> Ceramic forming by injection molding can be divided into several stages:

- Feed preparation
- Molding the part
- Removal of the organic vehicle.

Each of these stages has a significant role in the overall process and unless carefully controlled, the chances of attaining defect-free parts are almost nil.

### Feed Preparation

This stage represents the mixing and compounding of the mold constituents. Feed consists of two major components: inorganic ceramic powder and an organic vehicle that is made up of several polymers and additives. The objective is to have as high a ceramic fraction as possible (50 to 65 percent by volume) while maintaining the proper flow characteristics of the mix. The role of the organic vehicle is to provide easy flow of the ceramic powder into the mold cavity.

Characteristics of the powder impart a significant role in the quality and workability of the mix. Very fine powders ( $\ll 1 \mu\text{m}$ ) are not desired. They tend to have lower volume loading because of absorbed polymer layers and hinder removal of the organic vehicle. Agglomerate-free powders with a narrow particle size distribution are preferred to obtain a homogeneous feed and a

uniform green body. The chemical composition of the powder is insignificant except for its surface composition, which determines the powder/organic vehicle interaction.<sup>2</sup>

Choice of polymer composition is not trivial, and there is no universal recipe for deciding on the organic vehicle formulation. A proper organic vehicle should exhibit a melting range that is suitable for injection molding and be chemically stable at the operation temperature to avoid premature degradation.

The mixture is compounded to obtain a homogeneous mixture. Usually powder is mixed with a low-molecular-weight, surface-active additive, followed by the addition of waxes and polymers. The mixture is blended at high shear rate for a short time, followed by compounding at a lower rate. Compounding action will also take place in the screw extruder prior to injection molding.

### Modeling

Molding of ceramic suspensions by injection molding is not much different than that used in polymer injection molding. Figure 1 is a schematic diagram of a typical injection molding unit used at Brunel University. The quality of the molded part is largely determined by the injection molding conditions and by the characteristics of the ceramic suspension. The quality of the parts produced is

determined by the rheology of the suspension and its thermomechanical properties under the operational conditions. For most molding operations, a viscosity of less than 1000 Pa s and a shear rate value between 100 and 1000 s<sup>-1</sup> are required.

An acceptable feed should exhibit a low but finite-yield strength so that it flows under the applied pressure to fill the mold but does not slump when the pressure is removed. Feed should also exhibit pseudoplastic or Bingham solid characteristics for proper flow characteristics. Furthermore, the dependence of the feed viscosity to temperature should be as low as possible to avoid large changes in flow behavior with small temperature fluctuations.<sup>3</sup>

### Removal of Organic Vehicle

Once the part is molded with ceramic suspension, the organic phase should be removed without introducing macroscopic defects. Binder removal is a combined process of diffusion, evaporation, and decomposition of the organic phase out of the molded compact.

There are a few guidelines for successful removal of the binder phase. First and foremost, the binder should decompose over a wide temperature range to avoid destructive evolution of the gases. Second, diffusivity of the polymer through the packed ceramic particles should be high enough that it evaporates or decomposes at the external

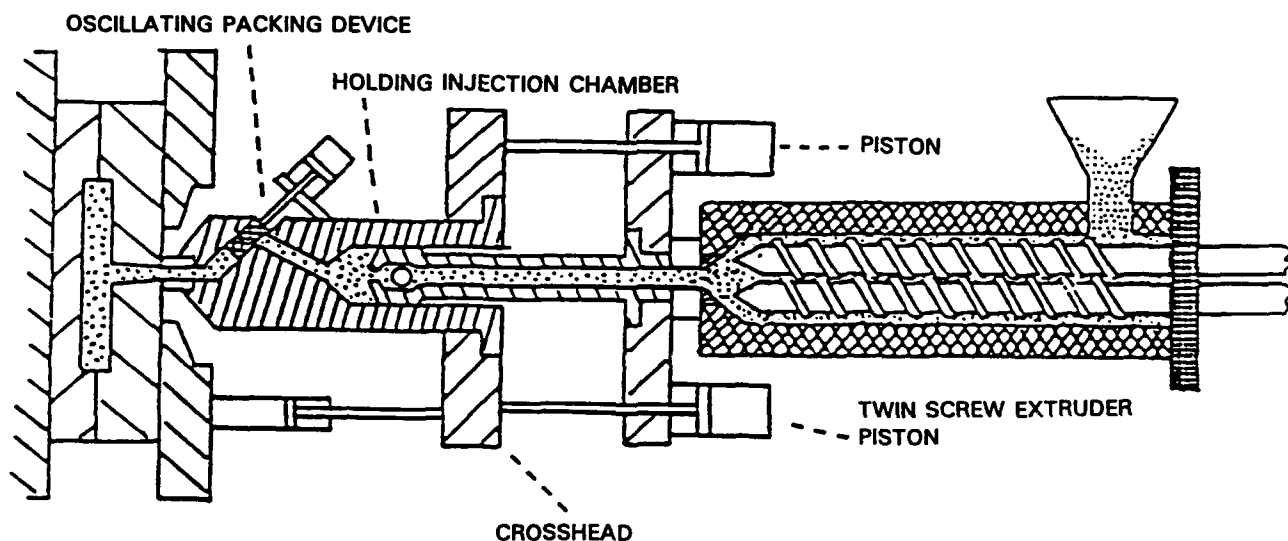

Fig. 1 — Twinscrew oscillating valve compounding injection molding machine

surface of the part rather than within the body, which causes bloating. An additional requirement of successful binder removal is that the ceramic residue left behind retain its integrity and exhibit sufficient mechanical strength to survive the handling and heat treatment stage without deformation and/or failure.<sup>4</sup>

Thermal characteristics of individual organic components are useful guidelines but are not sufficient to describe the behavior of the complex assembly of various ceramic suspension. Thus, until a significant database is established and better computer modelling is developed, it is necessary to determine individually the thermal decomposition behavior of each ceramic suspension formulation. Furthermore, it is advisable that the diffusion, evaporation, and thermal vs oxidative degradation of the suspension be determined experimentally.

## INJECTION MOLDING RESEARCH

The foregoing review of ceramic injection molding clearly shows that the process is extremely complex and requires systematic and careful investigation before a scientific understanding can be brought about. Only after such an understanding is established can basic principles be applied to the manufacture of ceramic parts with greater reliability and reproducibility. Scientists at Brunel University are trying to accomplish this goal, and they are at the cutting edge. Their efforts in this area are exemplary and are the subject of the remainder of this article.

### Characteristics of Ceramic Suspensions

To identify the sources and eventually alleviate defects formed during injection molding, certain physical characteristics of the ceramic suspensions must be determined. To model the solidification of suspension by computer simulation, all pertinent properties of the suspension must be known. Evans and his group determine the Poisson's ratio, Young's modulus, variation of viscosity with ceramic powder loading, and temperature.

Poisson's ratio of the ceramic suspension at 56 percent alumina loading was found to be 0.286. The organic vehicle used in this study consisted of isotactic and atactic polypropylene, and stearic acid in the ratio of 4:4:1. Poisson's ratio decreased

with increasing ceramic content and could be predicted by the rule of mixture if relative ceramic volume  $V_{rc} = V_c/V_{max}$  is used instead of ceramic volume fraction  $V_c$ , where  $V_{max}$  is the maximum ceramic volume fraction at which particles come in contact (about 68 percent by volume). The effect of strain on the Poisson's ratio is negligible.<sup>3</sup>

Young's modulus of the ceramic suspensions were measured by three different methods to get reliable values at elevated temperatures, and to account for time-dependent response of the organic phase. Suspensions show good linear elastic behavior at room temperature, but at elevated temperatures, the stress-strain curve can be fitted to

$$\sigma = B\xi^n,$$

where  $B$  and  $n$  are determined from regression curves,  $B$  decreases from 7.66 to 0.08 and  $n$  from 1 to 0.64 as the temperature is increased from 20 to 70°C. The elastic modulus decreased as a function of temperature from 7.7 to 1.3 GPa as the temperature is increased from 20 to 70°C. A relationship between Young's modulus and temperature can be expressed by

$$\log E = \log E_0 - bT.$$

Young's modulus was found to vary with ceramic loading as well. The relationship between the relative Young's modulus  $E_1 = E/E_0$  and the ceramic powder loading is expressed as

$$E_r = \left[ \frac{V_{max} - CV}{V_{max} - V} \right]^2,$$

where  $V_{max}$  and  $V$  are maximum and given ceramic volume fraction under consideration, and  $C$  is an empirical constant. For this study,  $C = 0.25$  gave the best fit to the experimental data.

Another important set of parameters relating to ceramic injection molding is the melt rheology. Successful suspension for injection molding should have a pseudoplastic behavior, i.e., the flow behavior index  $n$  should be less than unity in the following expression:

$$\eta = k\dot{\gamma}^{n-1}.$$

For this investigation, Evans and his coworkers have used silicon powder as a precursor to

reaction-bonded silicon nitride (RBSN) at a solids loading of 65 volume percent.<sup>5</sup> The binder phase contained polypropylene and a minor binder (a low molecular weight wax) at a volume ratio of 3:1.

Melt flow index measurements did not give reliable measurements, and hence they were not useful in assessing the formulations' moldability. Simple shear stress-strain plots did not produce any yield stress values. However, when Casson's equation was used,<sup>4</sup>

$$\tau^{1/2} = \tau^{1/2} + (\mu_{\infty} \dot{\gamma})^{1/2},$$

where  $\mu_{\infty}$  is the viscosity at very high shear rates. Plots of  $\tau^{1/2}$  vs  $\dot{\gamma}^{1/2}$  produced yield stress that ranged from 4 to 11 kPa for 48 to 60 percent by volume alumina powder loading. Increasing the solids loading to 64 percent more than doubles the yield stress, to 24 kPa. Thus, solids loading of 55-60 percent was considered optimum.

Fluidity index, defined as the reciprocal of viscosity at a given temperature (225°C for this case), and a specified shear rate (108 s<sup>-1</sup> in this case) showed that almost all the formulations studied were suitable for injection molding, i.e., fluidity index was greater than  $1 \times 10^{-5} \text{Pa}^{-1} \text{s}^{-1}$  for the solids loadings studied.

It is remarkable that in spite of considerable differences in binder composition, the above characteristics were insensitive indicators. Temperature dependence of the viscosity on the other hand, showed the greatest variation with the composition. They ranged from 1.4 to 28 kJ mol<sup>-1</sup>. It was found to be a crucial characteristic of the binder, which determines the moldability of a given suspension.

### Thermal Behavior of Ceramic Suspensions

One of the major sources of macroscopic defects in ceramic injection molding is nonuniform solidification of the melt in the mold. Low specific heat of the ceramic component, relatively high thermal diffusivity, and a high thermal expansion coefficient of the binder phase are responsible for formation of voids in the mold. Defects formed during molding was assessed by molding a ceramic suspension into a step-wedge mold with a thickness ranging from 2 to 20 mm in six steps.<sup>6</sup> Pieces were molded at various injection

molding pressures. Most of the defects were found to have been formed in the thickest sections, namely 15 and 20 mm, and at lower applied pressures. At a pressure of 129 MPa (maximum available), defects were almost nonexistent.

The qualitative explanation for the formation of voids in the center of the molded part is as follows: when the melt is injected to mold under pressure, the suspension in the mold starts to freeze, forming a rigid envelope. At this, the sprue is molten and will continue to fill the mold to counter the volumetric shrinkage from temperature drop. At a later stage, the sprue freezes before the center of the mold does, and pressure cannot be exerted to the mold from the sprue. When the center freezes and shrinks, at one point the pressure drops below the level of equilibrium vapor pressure of the organic vehicle. This causes some evaporation and formation of a void space in the center. Obviously, part of the shrinkage is compensated by the expansion of the melt upon removal of the pressure. Thermal contraction by freezing the suspension is due to the mean thermal expansion coefficient of the suspension and crystallization of the polymer component upon cooling. Contribution of ceramic is insignificant. However, thermal contraction due to crystallization of the polymer is a major concern and should be minimized by proper choice of the polymer blend.

Fortunately, it appears that the presence of ceramic powder in the mixture reduces the degree of crystallinity of the polymer because of its adsorption onto the particle surface. Another issue is to use additives that have relatively low vapor pressures so that the system will not become unstable with respect to pressure as the system cools.

Elimination of voids by application of high pressure is no guarantee for defect-free parts. Parts that were molded at high pressures exhibited hairline cracks due to thermal stresses that built as a result of nonuniform cooling. Obviously, continuous and nonuniform cooling, reduction of pressure, changes in the state of matter (solidification, crystallization), along with other variables of a complex material assembly are not easy to handle. The above discussion clearly shows that predicting solidification behavior of ceramic suspensions is an extremely complex task.

## Binder Removal

Removal of the organic vehicle from the molded parts is carried out at a temperature above the softening point. Depending on the atmosphere selected, the organic phase removal can take place in several forms: diffusion of liquid from the pore channels outward, evaporation of the organics, and oxidative degradation and evolution of oxidized gaseous product. Most binder removal processes are carried out at high enough temperatures that a large fraction of the binder is removed in the form of gases. It should be remembered that although the binder constitutes roughly 40 volume percent of the molded part, when removed in the gas form, the volume is on the order of 200 to 300 times that depending on the size of the gaseous molecules produced. Another approach is to remove the binder in the form of liquid through a powder bed by capillary action. The method utilizes powder pack to extract the liquid polymer from the mold. Evans and his group studied the role of powder pack characteristics in effective removal of the organic vehicle.<sup>7,8</sup> Two molded samples with identical processing conditions except the powder particle size were subjected to binder removal in powder packs that had varying chemical (alumina, zirconia, and silica) and particle sizes (ranging from 6  $\mu\text{m}$  for alumina to 0.1  $\mu\text{m}$  for zirconia and silica). After 24-hour heat treatment at 80°C, the fraction of paraffin wax that could be removed ranged between 17 and 20 percent for fine alumina powder containing mold, and 26 and 33 percent for coarse alumina. Remarkably, for coarse alumina mold in contact with fine silica powder-pack, 85 percent of the wax was removed! This unusually high wax removal compared to other systems was not elaborated much, but it demonstrates the role of differential pore channel size between the mold and the powder pack.

An appropriate binder system should have a relatively monotonic thermal expansion to prevent abrupt thermal expansion spikes as observed in the melting of crystalline polymers. In addition, an ideal binder will have a steady thermal decomposition over a wide temperature range to avoid catastrophic failure of the part. To choose a proper binder formulation, scientists at Brunel University have tried about 20 compounds (polymers, waxes, plasticizers, and lubricants). Thermal decom-

position of each compound has been experimentally determined and digitized. The data were used to predict the thermal decomposition of synthetic blends for numerous combinations. Optimum blends were selected by minimizing the sum of the square of the differential weight loss,  $(dW/dT)^2$ , over the whole temperature range.<sup>9</sup>

Another important factor in binder removal is the gas atmosphere that is used. To shed some light on the role of atmosphere, Edirisinghe<sup>1</sup> studied pyrolysis of compression-molded alumina parts at a loading level of 60 percent (by volume). The organic phase consisted of isotactic polypropylene, atactic polypropylene, and stearic acid at a weight ratio of 4:4:1. The samples were subjected to static air, flowing air, flowing oxygen, and flowing nitrogen atmospheres. The samples pyrolyzed in static and flowing air atmosphere showed no macroscopic defects, whereas the ones in flowing oxygen and nitrogen showed severe bloating. Bloating in a nitrogen atmosphere is attributed to slow diffusion of degradation products from within the body. The presence of oxygen in the gas mixture causes formation of oxidized products that are smaller in size and they diffuse much faster. Under microscopic examination though, these samples showed fine cracks starting from the surface. It is claimed that binder removal from the surface causes particles to pack more efficiently and shrink, but the shrinkage was restricted by the center of the body. Radiographic analysis also indicated a large void in the center of the specimen. This indicates that once the surface becomes rigid, binder removal in the center and associated shrinkage as a result of more efficient particle packing creates voids within the body. Defect formation in flowing oxygen atmosphere is attributed to oxidative decomposition at relatively low temperatures and in a narrow temperature range. Thus the degradation products cannot diffuse fast enough and this causes disintegration of the part.

## SUMMARY OF INJECTION MOLDING DEFECTS AND THEIR SOURCES

Defects related to the injection molding process arise from a variety of processing steps.<sup>10,11</sup> Results presented above can pave a way for us to list the types and sources of these defects



in summary form and probably direct our attention to elimination of them by carefully designing experiments. This list might also serve as a guideline for developing new formulations, designing new tooling, and implementing new processing protocols if injection molding is to become a practical method for fabricating complex ceramic shapes.

*Defects formed during mixing stage:*

- Presence of agglomerates. Ceramic powders are often agglomerated in the dry state. Most of the agglomerates are expected to break up during compounding. However, hard agglomerates may survive this operation.
- Undispersed organic vehicle. Since the organic vehicle consists of several polymers and additives with varying softening temperatures, these phases may not be dispersed completely if the temperature is not high and/or time is not long enough.
- Abrasive contamination. Although this defect has not been addressed in the foregoing text, blending operations may introduce metallic contamination. This problem is particularly serious for hard materials with large and irregular particle size.

*Defects formed during molding stage:*

- Weld lines. This defect is primarily due to poor design of the mold machinery. If the flowing suspension runs into obstacles that split the feed, weld lines will develop and are a cause of weakness in the final part.
- Incomplete mold filling. This is a more common problem in ceramic suspensions than in polymer injection molding. The primary culprit is the low specific heat and high thermal diffusivity of the ceramic component in the feed, which causes it to solidify prematurely in the mold.
- Residual water. A significant quantity of water can adsorb on the surfaces of fine ceramic powders. If not sufficiently dried during compounding and extrusion, the residual water can cause bubble formation as the mold is heated.

- Voids due to nonuniform shrinkage. As discussed above, these voids were found in the thicker sections of the mold and are due to evaporation of organics in the center of the mold as the surface layers freeze and shrink (one of the most serious defects in ceramic injection molding).
- Cracking. Application of high pressure may alleviate the problem mentioned above but it causes development of a significant level of residual stresses. These stresses may result in surface cracks either during molding or during subsequent heat treatments.
- Deformation during mold ejection. This problem arises from either insufficient cooling or low yield strength of the molded part. Ejection pin indentations and slight slumping under gravitational forces are common, especially parts with large aspect ratios.
- Surface degradation. This is not a common problem unless the part is left in the mold excessively long and polymer degradation takes place on the surface of the mold.
- Contamination from the machine. Just like in the compounding stage, there is a potential for steel contamination from the molding machine itself.

*Defects formed during binder removal stage*

- Deformation upon heating. When the mold is heated to remove binder, deformation may be observed if there are residual stresses that are frozen-in during molding.
- Cracks due to thermal shock. If the parts are heated too fast to binder removal temperature, thermal shock combined with the residual stresses may cause cracking of the part. This can be avoided by judicious choice of heating program.
- Bloating. This is one of the more serious defects during binder removal stage. Bloating occurs when thermal degradation and gas formation is faster than the diffusion through the pore channels. If thermal degradation occurs below the softening point, the sample may fracture.
- Slumping and cracking. Slumping results during binder removal if the ceramic loading

is not high enough and/or binder removal temperature is too high. If the polymer removal is nonuniform, stresses may build in the thinner sections due to shrinkage by the binder removal. Sometimes these stresses are high enough to cause cracks.

- Delamination of surface. The exact cause of this defect is not clear but preferential degradation of surface layers followed by shrinkage is one possibility.

As seen from this listing, the causes of defects are many and sometimes their sources are not well understood. In other cases, remedies for one defect accentuate the occurrence of another. Defects in general seem to be more serious with parts having thick sections or large variations in the thickness. Understanding of these defects and their alleviation will be a subject of research for years to come.

## SUMMARY

Injection molding of ceramic suspensions offers an opportunity to fabricate near net shape parts with low reject rates, provided the defect-generating sources are properly identified and eliminated. Dr. Evans' group has done a great deal of work in understanding the critical parameters and difficulties in using injection molding for fabricating ceramic parts. Obviously the group at Brunel University represents one of the best research teams in this field.

Analysis of the injection molding work discussed above leads to certain general observations:

- Chemical composition of the ceramic powders, with the exception of surface interaction with the binders, is not critical in the success of the process. Morphology of the powders however, imparts a significant role in the integrity of the molds produced. Particle size distribution, average particle size, and shape of the particles play significant roles, both in flow characteristics of the suspension and on the binder removal.
- The organic vehicle consists of a mixture of components. The major component is usually a high molecular weight thermoplastic

or a blend. Minor components consist of several organic compounds: a wax to aid the deformation and flow of the suspension; a plasticizer to lower the viscosity; and other additives such as surface active agents to improve the wetting between powder and the binder and lubricants to reduce the die wall friction. Isotactic polypropylene, atactic polypropylene, and stearic acid in the weight ratio of 4:4:1 were found to be successful in many cases.

- A number of defect sources were identified. Among them, voids and cracks formed during freezing of the polymer in the mold and those generated during binder removal were shown to be the most critical. Characteristics of the binder composition such as high vapor pressure, and large, sharp thermal dilatation of organic components were considered to be important parameters. Process variables including injection pressure and temperature, and the mold geometry addition, deformation, and failure during mold ejection, and during storage were also mentioned.

The complexity of the system and the enormous number of variables that have to be controlled in experimental trials require development of computer modeling of the injection molding and binder removal. This part of the investigation has just begun, but it promises to be a very demanding endeavor. It will be interesting to see the fruits of this investigation in the years to come.

## REFERENCES

1. M.J. Edirisinghe, "Binder Removal From Moulded Ceramic Bodies in Different Atmospheres," *J. Mat. Sci. Lett.* **10**, 1338-1341 (1991).
2. J.R.G. Evans and M.J. Edirisinghe, "Interfacial Factors Affecting the Incidence of Defects in Ceramic Mouldings," *J. Mat. Sci.* **26**, 2081-2088 (1991).
3. T. Zhang and J. R. G. Evans, "Mechanical Properties of Injection Moulding Suspension as a Function of Ceramic Volume Fraction

- and Temperature," *J. Europe. Ceramic Soc.* **7**, 155-163 (1991).
4. M.J. Edirisinghe, H.M. Shaw, K.L Tomkins, "Flow Behavior of Ceramic Injection Moulding Suspensions," *Ceram. Int.* **18**, 193-200 (1992).
  5. M. J. Edirisinghe and J. R. G. Evans, "Properties of Ceramic Injection Moulding Formulations Part I Melt Rheology," *J. Mat. Sci.* **22**, 269-277 (1987).
  6. M. S. Thomas and J. R. G. Evans, "Non-Uniform Shrinkage in Ceramic Injection-Moulding," *Br. Ceram. Trans. J.* **87**, 22-26 (1988).
  7. J. K. Wright and J. R. G. Evans, "Removal of Organic Vehicle from Moulded Ceramic Bodies by Capillary Action," *Ceram. Int.* **17**, 79-87, (1991).
  8. Y. Bao and J. R. G. Evans, "Kinetics of Capillary Extraction of Organic Vehicle from Ceramic Bodies. Part 1: Flow in Porous Media," *J. Europe. Ceram. Soc.* **8**, 81-93 (1991).
  9. S. J. Stedman, J. R. G. Evans, and J. Woodthorpe, "A Method for Selecting Organic Materials for Ceramic Injection Molding," *Ceram. Int.* **16**, 107-113, (1990).
  10. J. G. Zhang, M.J. Edirisinghe, and J. G. Evans, "A Catalogue of Ceramic Injection Moulding Defects and Their Causes," *Industrial Ceram.* **9**(2), 72-82 (1989).
  11. M.J. Edirisinghe, "Fabrication of Engineering Ceramics by Injection Moulding," *Ceram. Bull.* **70**(5), 824-828 (1991).

### Contact

Julian R. G. Evans BSc, PhD, CEng, MIM  
 Reader  
 Department of Materials Technology  
 Ceramics Fabrication Group  
 Brunel The University of West London  
 Uxbridge, Middlesex UB8 3PH  
 Phone: +44 895 274000 Ext. 2371/2972  
 Fax: +44 895 232806  
 Telex: 261173 G7

---

## Ceramic Processing Research at the Fraunhofer Institute-Würzburg

*by Mufit Akinc, former Liaison Scientist for Materials Science at the Office of Naval Research European Office. Dr. Akinc is Professor of Materials Science and Engineering at Iowa State University.*

**KEYWORDS:** ormocers; sol-gel processing; coatings; synthesis; nonmetallic materials

### INTRODUCTION

This report describes research being carried out at the Fraunhofer Institute for Silicate Research in Würzburg, Federal Republic of Germany (FRG). Research at the Fraunhofer Institutes is applied in nature and aimed at industrial applications. To appreciate their activities and accomplishments as well as provide an example of transitioning the basic science to industrial practice, we briefly describe the Fraunhofer Institutes.

### FRAUNHOFER INSTITUTES

The primary mission of the Fraunhofer Institutes is to conduct applied research that is aimed at industrial applications, to contribute to the competitiveness of German industry in the global marketplace. Fraunhofer institutes have a crucial place in the research and development (R&D) arena—between institutions carrying out fundamental research (the Max-Planck Institutes and universities) and market-driven developmental work being

carried out in industry. They also provide an indispensable research platform for small- or medium-size companies who cannot afford to maintain separate research and development laboratories.

In the United States today, the need to establish active links between research and industry is critical. To meet these needs, we are developing new formulas for research management. These include locating research parks near university or federal government laboratories, engineering centers of excellence, and technology development centers. The structure of the Fraunhofer institutes, which has been successful for many decades in the FRG, can provide a model for the U.S.

The Fraunhofer Society contains 48 research institutes; 39 have been established over a long period of time in West Germany, and 9 were recently established in East Germany after the unification. These institutes are grouped into 9 disciplinary departments:

Department	No. of Institutes	No. of Employees
Microelectronics	8	1000
Information Technology	5	800
Production Automation	6	800
Production Technologies	4	500
Materials and Components	10	1100
Process Engineering	5	700
Energy and Construction Engineering	3	350
Environmental Research and Health	5	600
Studies and Technical Information	4	400

These numbers of both institutes and employees are not exact. Some institutes can be considered under more than one department, and the number of employees fluctuates from year to year. Including the temporary and administrative support staff, total employment in the Fraunhofer institutes reaches 7800. More than two-thirds of these employees are budgeted as scientific and professional staff, the remaining are supported by "soft money" through external contracts.

Total budget for the Fraunhofer institutes for 1992 was more than DM 1 billion (U.S. \$650 million). Approximately 90% of this is spent on re-

search programs; the remaining 10% is for new facilities construction and one-time equipment acquisitions. This relatively large proportion and steady funding for construction and equipment is responsible for the high quality of the infrastructure that the Fraunhofer institutes have been enjoying over the past several decades. Because nine new institutes have been established in the new states (what used to be the German Democratic Republic), a large portion of the funding for construction and equipment has been shifted to these new institutes. Unless the total funding level increases significantly in the next few years, the institutes will feel the budget pressure—simply because of the 20% increase in the number of institutes that have to be supported. Future support level for the Fraunhofer Institute is not clear, but the general consensus is that the overall budget will remain flat for at least several years. Considering the fact that the newly established institutes need substantial funding for infrastructure and research initiation, the outlook for most institutes in the West Germany is bleak.

Fraunhofer institutes that have materials-related research and development activity are:

- Institute for Applied Materials Research
- Establishment for Applied Polymer Research
- Establishment for Ceramic Technologies and Sintered Materials
- Establishment for Electron Beam and Plasma Technology
- Institute for Thin Films and Surface Engineering
- Institute for Silicate Research
- Institute for Mechanics of Materials
- Institute for Strength of Structure under Operational Conditions
- Establishment for Material Physics and Thin Film Technology
- Institute for Nondestructive Testing.

A typical institute employs approximately 100 scientific and technical staff and 50 students or part-time research assistants. Most Fraunhofer institutes are established near a university or college. The university provides students, extensive library facilities, and some facilities not available at the institutes. Some of the scientists at the institutes hold professorships at the university but do not

have any significant teaching responsibilities. An average size Fraunhofer institute has an annual budget of about DM 16 million (U.S. \$10 million). Federal and state governments and industry provide most of the funding; less than 20% of the funding comes from international agencies. Industrial support equals or exceeds that of government support in some institutes. This shows the significant role that the Fraunhofer institutes play in German industrial R&D. Every institute's research direction is reviewed periodically (typically every five years), and the position of the institute is adjusted whenever necessary as technological and market conditions warrant.

Some institutes have demonstration centers whose mission is to transfer the technologies developed at the institute to industry. In demonstration centers, the major contribution comes from a single company or from a consortium of industrial partners. When a consortium is involved, each industrial partner is given exclusive rights for a specifically defined application of a specific research effort and output.

### **FRAUNHOFER INSTITUT FÜR SILICATFORSCHUNG**

This institute was established in 1926 in Berlin as the Kaiser-Wilhelm Institute für Silikatforschung and was relocated to Franconia during World War II. After the war, it was operated as a Max-Planck Institute until 1971, at which time Fraunhofer-Gesellschaft took over the institute and "Institut für Silikatforschung" acquired its present status.

The primary mission of the institute is to conduct applied research in the area of nonmetallic materials; primary emphasis is on glasses and ceramics. However, developments in preceramic polymers and sol-gel processing have made the distinction between ceramics and polymers research less clear. The goal is bridge the gap between fundamental research and practical application. Although the main purpose is to carry out applied research for industrial concerns, the institute conducts fundamental research in the area of non-metallic materials where potential high-risk, high-pay-off ideas are tested. These include developing new inorganic-organic polymers with color centers on the polymer chain, new processing routes for ceramic powders with controlled morphology, and ceramic fibers from sol-gel routes. On the other

side of the research spectrum, the institute has a technology application and demonstration center that extends the research from laboratory scale to a demonstration plant, and transfers the technology developed at the institute to industrial partners.

Fraunhofer Institut für Silicatforschung (ISC) is specialized in the area of glass, ceramics, and ormocers (organically modified ceramics), and the three areas constitute the research departments of the institute. In addition to these, the institute has an analytical department that is primarily a service department to the others but has some research programs of its own. Research efforts at the institute can be categorized under

- Materials Development,
- Materials-related Technology,
- Characterization of Materials and Processes, and
- Technology Transfer.

The range from materials development to technology transfer clearly shows the vertical integration of research activity at this institute.

The Glass Department is involved in many aspects of glass-related problems. Compared to the development of new melt glass for bulk glass production, greater emphasis is given to the development of glass coating materials on various surfaces including metals, ceramics, and glasses; development of new applications for traditional and new glasses; and development of new characterization techniques. One area receiving more attention recently is the monitoring and prevention of glass corrosion. ISC has developed sensors that are placed in a number of historical buildings to monitor corrosive activity on glazed surfaces and stained glass. In these sensors, a glass layer that is more sensitive to corrosion by acid rain is applied over the original glass and the corrosion is monitored as a function of time. I am told that these sensors are also being used in vineyards to monitor acid rain effects on the grapevines. Another active area is the development of coatings to protect glass against weathering. These coatings are based on sol-gel processing and are mostly ormosil (organically modified silicate) type materials that can be applied by dip coating, spraying, spinning, and silk screen printing techniques. The Glass Department has also developed glasses with adjusted

thermal expansion coefficient, fibers for optical data transmission, and functional coatings for analytical and preparative applications.

The Ceramics Department at ISC has well established expertise in preparing nonmetallic materials and in processing nontraditional ceramics. Its primary research is the processing of silicate-based materials by the sol-gel method. Recently, they have established a rather significant level of effort in synthesis of uniform powders by chemical routes. They have investigated the synthesis of yttria, alumina, PZT, and yttria-stabilized zirconia powders. Sol-gel processing has been extended to nonsilicate chemistry including alumina, PZT, and other compositions for electronic applications. Oxide and non-oxide-based sols are used to form coatings on various substrates. These coatings range from functional electroceramics to structural and protective applications. Fiber spinning from sols has also been accomplished for producing alumina fibers.

The Ormocer Department was established only several years ago, but it already constitutes a significant activity within ISC. Ormocers (organically modified ceramics) encompass an area of research that overlaps organic polymers, silicones, and inorganic polymers. If one considers the enormous possibilities in properties that are achievable with organic polymers alone (by varying the composition and molecular architecture) and, similarly, the wide range of properties possible with inorganic polymers such as oxide gels, the possibilities for ormocers, which combine the two types of polymers, appear to be endless. The basic approach to synthesizing ormocers involves controlled hydrolysis and condensation of alkoxides (such as that of silicon, aluminum, titanium, zirconium and many others individually or in combination) to form an inorganic polymer network. If functional organic groups are attached to the metal atoms in the alkoxide, an ormocer precursor sol is obtained. Curing the precursor sol by any one of the well-known techniques results in an ormocer material. One way to cure the precursor is by polymerizing these organic groups to form a hybrid inorganic-organic polymer system. Careful selection of the functional groups leads to materials with tailored mechanical, electrical, optical, and chemical properties. The primary advantage of ormocers is that they can be applied to organic- or inorganic-

based substrates. They exhibit the better thermal and mechanical properties of inorganic polymers yet they offer some of the characteristics that are unique to organic polymers (for instance, ease of processibility, and optical and electronic properties). Potential applications have not been fully explored, but some obvious applications include:

- scratch- and weathering-resistant coatings,
- passivation and insulating coatings,
- optoelectronic applications,
- nonlinear optic materials,
- adhesives between inorganic and organic materials,
- corrosion protection coatings,
- carriers for special catalysts and enzymes,
- filters and membranes,
- solid state ion conductors and sensors, and
- biomaterials.

Some of the applications are currently being explored at the ISC. The Center for Coating Technology is working on several applications for technology transfer.

Although the Analytical Department's main purpose is to assist other departments and respond to the needs of industry, it has its own research program as well. The department is well equipped to carry out analytical work in materials analysis and characterization. Chemical analysis is carried out by a large number of state-of-the-art spectroscopic, chromatographic, and gravimetric instruments. Chemical, structural, and morphological characterization of powders, coatings, and bulk materials is accomplished by optical and electron microscopies, X-ray diffraction, scattering, and photoelectron spectroscopies, and particle size and image analyzers. This department is also responsible for materials testing. Mechanical, environmental, thermal, and rheological characterization is done routinely. Research efforts are directed toward improving and developing new analytical techniques for materials characterization. They are also assisting industry by providing special analytical services and measurement protocols to establish statistical process control.

#### CENTER FOR COATING TECHNOLOGY

The Center for Coating Technology was established to transfer the technology developed at

the ISC institute. The center is housed in a separate building, which allows it to carry out its mission as an autonomous entity. The projects are extensions of the ormocer research at the institute. The center has contracts with several small-to-medium size companies from the region to use and demonstrate its coating technology. Although all of the projects are based on ormocer coating, the chemical composition of the ormocer, application techniques, and the substrate they are applied to varies. Thus, many companies can benefit from a single, broadly based research project without being in direct competition for the same market. These companies are licensed for a particular application. For instance, one company has the rights to use this process for coating metal substrates against corrosion and weathering, another company for scratch-resistant coating of optical lenses, another company for insulating and protective coating of electronic packages, yet another for color coating of domestic glass containers. This multiple client arrangement not only provides sufficient funding to carry out a significant technology transfer program but also provides a synergistic effect such that findings of a general nature benefit every company involved in the program.

Facilities available at the center include a surface cleaning and pretreatment laboratory; spray coating, dip coating, centrifugal coating facilities; and a testing and characterization laboratory. In addition to proof-of-concept-type experiments, the center carries out experimental work in scale-up, reliability and quality assurance, service-life prediction, and market analysis.

One must recognize that even at the research stage there is industrial funding for the institute. From this, several goals are accomplished: industry establishes a healthy relationship with the institute, has an influence on the type of research done at the institute, and has an edge on the processes or products that may result from the research. However, there is a potential risk of instability and/or interruption to research programs as a result of the uncertainty of continuing research support from industry.

#### **RESEARCH AT THE FRAUNHOFER INSTITUTE FÜR SILICATFORSCHUNG**

The Ceramic Department's research activity revolves around sol-gel processing and powder

synthesis by contemporary techniques. With respect to powder synthesis, scientists at ISC have investigated the synthesis of powders for structural applications such as alumina, mullite, cordierite, yttrium aluminum garnet, zirconia, zirconia-alumina composite, as well as electrical (functional) applications such as barium titanate, lead zirconate titanate, strontium titanate, and yttrium- and bismuth-based superconductors.

A number of different techniques have been used to produce chemically homogeneous oxide powders. Hydrolysis of alkoxides, hydrothermal synthesis, the emulsion route, and chemical coprecipitation techniques have been successfully used. The choice of method was partly determined by the chemistry of the powders but also by economic considerations. The emulsion technique is based on dispersing small aqueous droplets of cationic solution in a continuous phase of organic liquid, followed by either evaporation of water from the aqueous phase (emulsion evaporation) or precipitation of an insoluble salt within the aqueous droplet followed by separation of the solid particles from the emulsion (emulsion precipitation). The emulsion technique for preparation of fine powders has been pioneered in this laboratory in the mid-1980s. The technique provides the advantage of controlling the morphology and complex chemical compositions otherwise not possible by coprecipitation but it suffers from organic impurities that might be introduced during emulsion evaporation, and in some cases from economic disadvantages. Emulsion precipitation conditions are milder and have a broader application range but it is difficult to introduce anions into the aqueous phase of the emulsion through the organic continuous phase to induce precipitation. The group at ISC, as well as several others in Europe, have been able to overcome this difficulty by using a phase transfer catalyst as a reservoir for hydroxide ions. Scientists at ISC used this method in combination with spray drying to dry and separate the precipitated particles. The need for spray drying is not clear to me; it seems to defeat the purpose of controlling the particle size by emulsion droplets. Nevertheless, they have obtained relatively uniform spherical particles of  $\text{BaTiO}_3$ , and PZT.

The Ormocer Department is involved in developing compositions and processes for coating materials based on ormocers. For applications

where mechanical properties are important, such as high elastic modulus, flexural strength, and low thermal expansion coefficient, urethane methacrylate alkoxisilanes (UMAS) are being investigated.

## CONCLUSIONS

The Fraunhofer Society operates 48 institutes that carry out applied research in nine disciplines. Each institute is specialized in a specific area within a given area of technology. The primary goal is to build a bridge between the basic science and industry. They seem to do an excellent job at this. The U.S. might benefit from this model greatly.

The Fraunhofer Institut für Silicatforschung represents an excellent example of transfer of technology from laboratory to industrial practice. They draw on the basic research done at universities and government laboratories in Germany and abroad. The collaboration between industry and the Fraunhofer Institute is enviable. Industry seems to have a strong trust and confidence in the institute. The collaboration arises not only from needs expressed by industry as is the case in the U.S., but also from the fruits of the applied research done at the institute. That is, in some cases the institute pushes industry into new areas. The most striking example

of this type of collaboration is in the coating technology being developed at the technology center.

The Fraunhofer Society appears to have strong support from German industry. Since mutual trust has been established between industry and the institutes over decades of collaboration, Fraunhofer Institutes are in an enviable position. They are financially supported by the industry, the industrial partner actively participates in the technology development process and shares their know-how with the institute. In return, the institute carries out research and development projects to improve the industrial competitiveness of the partner(s) with an extreme sensitivity to partner's competitive position.

Fraunhofer Institute für Silicatforschung has built a considerable expertise in the area of sol-gel processing and its newest branch, ormocers. The institute's research projects in this area have resulted in the establishment of a technology center that develops processes and specific compositions for specific coating applications in collaboration with several industrial partners.

In view of the new wave of technology transfer efforts in the U.S., Fraunhofer institutes may represent a realistic model that is proven to have worked better than other formulas and systems tried and being formulated in the U.S. today.

---

# Policy

## New Directions for the Estonian Academy of Sciences and Universities and Institutes in Estonia

*by F.E. Russell, Research Professor of Pharmacology and Toxicology in the Health Sciences, College of Pharmacy, University of Arizona, Tucson.*

**KEYWORDS:** reorganization; priorities; agreements of cooperation; international cooperation

### INTRODUCTION

Like other areas in the former USSR, Estonia has experienced the difficult problems of inde-

pendence, particularly in its political and economic affairs. As would be expected, these problems are reflected in the organization, finances, and priorities of the Estonian Academy of Sciences (EAS),



which is the country's policy maker for its scientific community and the various institutes and universities.

During 1992 and 1993, most EAS activities were extensively modified because of deepening financial limitations. Emphasis has been placed on the more promising and urgent scientific projects primarily designed to improve the country's current economic needs. In doing this, however, the Academy appears to have been mindful that a viable applied science is highly dependent on the structure of healthy basic science. Nevertheless, the retrenchment of organizational units and personnel has required a more severe reduction in basic science personnel than in the more applied sciences. During 1992, the number of employees in the Academy was reduced by almost 700 (20 per cent), a reduction of 40 per cent from its staff number five years ago. More than 65 per cent of the personnel loss was in basic science areas.

#### **RELATIONSHIPS WITH OTHER ORGANIZATIONS**

The relationship of the various scientific institutes within the country to the EAS has also been drastically changed. No longer are the institutes subordinate to the central administration of the EAS. This has allowed the individual institutes to make their own administrative decisions, to regulate their research profiles, to adjust their own finances, and to oversee the use of their own property and facilities. Even the Academy's overview of capital building expenditures of the institutes has become relatively nonexistent.

The relationship between the universities and the EAS has also changed. There are now "agreements of cooperation" between Tartu University, Tallinn Technical University, and Tallinn Pedagogical University with the Academy. These agreements include joint chairs and professorships. In addition, some research units within the Academy, along with their projects, have been integrated into the universities. Finally, the Ministry of Environment has established a joint scientific relationship with the Academy, establishing the Estonian Marine Institute.

#### **COOPERATIVE EFFORTS**

International cooperation has greatly increased during the past two years. It is estimated that almost half of all scientific projects in Estonia are now cooperatively associated with foreign research teams, while the number of projects with Russia, the Ukraine, and other former parts of the USSR have been markedly reduced. What has been disappointing is the fact that in 1992 there was little opportunity to obtain new laboratory equipment. This has obviously affected those areas of science that are highly dependent on the advanced technical equipment of the 1990s.

In December 1992, a joint activities meeting of the Presidium of Estonia, Lithuania, and Latvia was held. The meeting focused on the role and function of the Academies in the general network of scientific organization of each country during this period of reconstruction. Other subjects of discussion included establishing a social security system for scientists and assessing scientific research areas of promise for their respective scientists. It was decided that each country should follow its own course as dictated by its economic, cultural, and scientific needs. However, the meeting Presidium agreed that a closer working relationship between the three countries should be encouraged in the hopes of improving the areas economy. For that reason a number of joint ventures were suggested.

#### **PROJECTS**

Research projects of the various EAS, institutes, and universities include:

- *Astrophysics and Atmospheric Physics*

A software package for analyzing irregularly spaced time series has been prepared. The package may be used not only in astronomy but also in geophysics, biophysics, and even in business procedures. Evidence has been obtained demonstrating that the large-scale structure of the universe is caused by large-scale initial perturbations that still

have capacities of deforming the existing small-scale structure in a coherent manner.

- *Applied Mathematics*

The inverse problem of determining two independent relaxation functions in the medium with memory has been solved by using reduction to a system of integral equations.

A continuous programming problem (Bellman's "bottleneck problem") in the space of essentially bounded functions has been replaced by a sequence of finite dimensional programming problems, and a strong convergence to the solution of the initial problem has been demonstrated.

- *Chemical Engineering*

A monograph, *Characterization of Oil Shales and Shale-like Rocks from Known Deposits and Outcrops*, has been published. Data on the organic and mineral composition of oil shales from approximately 100 deposits as well as the yield and properties of oil shales thermal decomposition products has been systematized. Dependence of the composition of Djamb oil shale (Uzbekistan) on its depositional conditions and subsequent thermal alterations has been established.

- *Ecology*

New data have been obtained confirming the concentrations of microcomponents (Li, Se, Sb, Cd, As, et al.) and  $^{226}\text{Ra}$  in North and North-eastern Cambrian-vendian waters. Similar studies have been carried out on mineral and certain table waters manufactured in Estonia that were found to be too high or even nonpermissible in these microcomponents.

The hydrophobicity of environmental pollutants aza-arenes, dibenz(ah)acridines (DBahACR), has been shown to be determined mainly by the nucleophilicity of the DBahACR and their steric features.

- *Geology*

Data have been obtained giving evidence that the greatest sea-level decrease in the temperature in the Baltic Palaeobasin took place at the end of the

Ordovician, i.e., simultaneously with the continental glaciation maximum on the Southern Hemisphere. In cooperation with Swedish scientists, a biozonal scheme of the Ordovician chitinozoans, which permits highly accurate dating of geological events, has been compiled.

- *Marine Science*

Expeditions in winter 1990-1991 demonstrated that the increased exchange of deep water between the Baltic Seas basins lasts through the entire winter. This is accompanied by changes in stratification and thermohaline structure that are opposite to the stagnation period governing trends.

- *Microbiology*

Experiments are being done with the insect cell line F\SF-9, demonstrating that cultured insect cells do not use fermentative metabolism and do not form lactate. This has made possible the development of a fed-batch procedure yielding cultures with high cell densities.

- *Molecular Biology*

Full-length cDNAs for known members of neurotrophic family (NGF, BDNF, NT3, and NT5) have been cloned. Evidence has been obtained that both BDNF and NT3, but not NGF, are the primary neurotrophic factors for the inner ear ganglia neurons, suggesting that neurotrophins function as the chemoattractants directing the growing nerve fibers toward the field of innervation.

Monoclonal antibodies against (2'-5')-oligo-adenylates (2-5A) have been raised. Experimental data have confirmed that an augmentation of lytic activity of natural killer cells and an increase in phagocytic activity of macrophages induced by 2-5A chemical analogs are dependent on the spatial structure of the analogs. The conclusion was drawn that 2'-5'-phosphodiester bonds play a critical role in enhancing the biological activity of cell-immune system components.

- *Physics*

A method of growing high-purity CsCl crystals has been devised. In CsCl crystals, three kinds of

intrinsic luminescence have been observed: luminescence of excitons, intra-band luminescence, and cross-luminescence.

A manual containing extensive data about atomic processes in a rarefied astrophysical media (especially in planetary nebulae) causing transitions in ultraviolet, visible, and infrared regions has been prepared.

Electron spins in a solid have been inverted by using a nonresonant method of ultrafast reversal of the magnetic field; a negative spin temperature has been achieved in a CaO crystal.

- *System and Computer Engineering*

Research into developing new methods and tools for building knowledge-based applications

with intelligent graphical interfaces has been carried out. A software package for designing hydraulic systems in the C-Priz programming environment has been built and compared to a similar NUT system application. A new dialog scenario system and scenario editor for C-Priz has been designed.

- *Zoology*

On the basis of chlorophyll fluorescence data and characteristics of carbon dioxide exchange, a phenomenon of daily light depression of photosynthesis was established and its influence on the level of net photosynthesis demonstrated. It has been shown that enhanced levels of carbon dioxide and ozone have synergetic effects on the aspen photosynthesizing apparatus.

**Office of Naval Research  
European Office**

**European Science Notes Information Bulletin**

**INDEX — Volume 93**

**CHEMISTRY**

Marine Corrosion and Fouling Subject of  
International Congress  
*J. R. DePalma and J. Lorenz, 05, 309-310*

Testing for Drug Use by Analyzing Hair  
*D. A. Kidwell, 08, 514-520*

**COMPUTER SCIENCE**

Eurographics '92  
*L. J. Rosenblum, 04, 262-265*

Scientific Visualization—A Snapshot of  
European Activity  
*L. J. Rosenblum, 06, 393-396*

Connection-Machine-Based Visualization at the  
German Center for Mathematics and Computer  
Science  
*L. J. Rosenblum, 07, 468-471*

Virtual Reality in the U.K.—Three Diverse  
Applications  
*L. J. Rosenblum, 08, 520-527*

The ONR Data Visualization Workshop  
*L. J. Rosenblum, 09, 557-569*

Research Directions in Fluid Flow  
Visualization  
*L. J. Rosenblum, 09, 569-573*

**ELECTRONICS**

III/V Electronics in Germany: Focus on the  
Fraunhofer Institute for Applied Solid State  
Physics in Frieberg  
*N. Bottka, 08, 527-537*

The Electronics Research and Development  
Landscape in the Former German Democratic  
Republic  
*N. Bottka, 09, 574-583*

**ENGINEERING**

Dynamics and Control Research at the  
University of Manchester  
*A. M. Janiszewski, 01, 53-56*

**ENVIRONMENT**

Changes in Fluxes in Estuaries: Implications  
from Science to Policy  
*C. J. Decker, 04, 265-270*

Methodologies for Determining Clean  
Technology Alternatives—European Research  
and Development  
*M. Overcash, 05, 289-308*

Dimethylsulfide, Oceans, Atmosphere, and  
Climate—An International Symposium  
*P. V. Hobbs, 06, 396-397*

European Countries Commit to Cleaner Manufacturing  
*M. Overcash, 08, 499-513*

Environmental Dimensions of Europe: An Assessment  
*M. Overcash, 09, 583-589*

The Structure of Frontal Weather Systems in Western Europe  
*P. Hobbs, 09, 590-594*

## MANUFACTURING

Electromechanical Design in Europe: University Research and Industrial Practice  
*D. E. Whitney, 01, 1-52*

New CAD Software from Dassault Systems: Starting to Combine Design and Engineering  
*D. E. Whitney, 01, 56-62*

Dramatic Reduction in Lead Time at Volvo Based on Restructuring the Design Process and Introducing the Computer  
*D. E. Whitney, 01, 63-70*

## MATERIALS

Quality Research and Productivity—The Dutch Treat  
*J. H. Magill, 01, 70-73*

Metrology and Research at the National Physical Laboratory, Teddington, U.K.  
*J. H. Magill, 02, 125-134*

The Pulsed High Magnetic Field Facility, Toulouse, France  
*R. J. Soulen, Jr., M. S. Osofsky, and S. A. Wolf, 02, 134-141*

Tribology in the Former U.S.S.R.  
*S. Jahanmir, 03, 161-165*

Personal Impressions of the Status of Tribology in the Former Soviet Union  
*I. Singer, 03, 165-168*

High-Temperature Structural Materials for Aerospace: The Situation in the United Kingdom  
*A. G. Evans, 04, 223-229*

Piezoelectric Materials Research in Europe  
*J. A. Sampson, W. A. Smith, S. Newfield, and G. Kavarnos, 04, 230-235*

Sol-Gel Processing Science in France  
*M. Akinc, 04, 235-246*

New Basic Materials and Applications of Electronically Conducting Polymers Highlighted at Swedish Synthetic Materials Conference  
*K. J. Wynne, M. Pomerantz, and J.R. Reynolds, 04, 246-253*

Selected Notes on Materials Research from European Laboratories and Workshops  
*J. H. Magill, 04, 253-256*

Diamond-Related Research, Technology, and Applications in Israel  
*J. E. Butler, 04, 256-262*

Crystallization of Polymers—A NATO Advanced Research Workshop  
*J. H. Magill, 05, 311-318*

Ceramic Matrix Composites Programs in France  
*A. G. Evans, 05, 318-323*

Oriental Phenomena in Polymers: The First St. Petersburg Polymer Meeting  
*J. H. Magill, 07, 471-479*

European Mechanics Research Community Organizes Itself  
*D. G. Crighton, 07, 479-482*

Ceramic Matrix Composites Technology in Europe: An Update  
*A. G. Evans, 08, 537-539*

Surface Force Measurements No Longer Limited to Mica: The Universal Force Microscope  
*M. Akinc, 08, 540-544*

A Process Borrowed from Polymers: Injection Molding of Ceramics at Brunel University, U.K.

*M. Akinc, 09, 595-602*

Ceramic Processing Research at the Fraunhofer Institute-Würzburg

*M. Akinc, 09, 603-608*

## **MATHEMATICS**

Mathematical Modeling and Representing Objects in 3-D Space—Freeform Curves and Surfaces '92

*G. M. Nielson, 03, 169-174*

## **MECHANICS**

Cavitation and Cavitation Erosion Addressed at International Conference

*E. P. Rood, 06, 397-399*

## **OCEANOGRAPHY**

U.K. Contribution to Climate Research: The Rennell Centre for Ocean Circulation

*J. P. Dugan and T. H. Kinder, 01, 73-80*

Coastal Ocean Research at the Proudman Oceanographic Laboratory

*J. P. Dugan and T. H. Kinder, 02, 142-150*

Investigating a Possible Submarine Volcanic Eruption by Using Russian Mir Submersibles: Implications for Cooperative Work

*L. E. Johnson, 02, 150-154*

Assessments of Oceanographic Institutes in the Former Soviet Union

*J. P. Dugan, 03, 157-160*

Physical Oceanography in the Ukraine: The Marine Hydrophysical Institute

*J. P. Dugan and L. Jendro, 03, 175-186*

Review of Physics Research at the P. P. Shirshov Institute of Oceanology—The Largest Oceanographic Institute in Russia

*J. P. Dugan, 03, 186-201*

Valuable Oceanographic and Marine Meteorology Research at the State Oceanography Institute in Moscow

*J. P. Dugan, 03, 202-212*

Who's Doing What in U.K. Ocean Engineering—The Marine Technology Directorate

*J. A. Sampson, 04, 271-273*

Technology for Unmanned Underwater Vehicles

*J. A. Sampson, 04, 274-278*

Coastal and Nearshore Research at the Laboratori d'Enginyeria Marítima (Polytechnical University of Barcelona, Spain)

*S. Elgar, 04, 278-281*

Coastal Ocean Forecasting Systems in Europe—Part 1

*J. P. Dugan, 06, 365-392*

Coastal Ocean Forecasting Systems in Europe—Part 2

*J. P. Dugan, 07, 433-468*

Remote Sensing of the Coastal Zone

*J. P. Dugan and R. P. Mied, 06, 399-406*

Swords Into Plowshares: U.K. Oceanographic Research Autonomous Underwater Vehicle

*J. A. Sampson, 06, 406-409*

The AUTOSUB Project

*J. A. Sampson, 06, 409-413*

The Structure of Oceanographic R&D In France: Physical Oceanography and Remote Sensing at IFREMER

*J. P. Dugan and J. A. Sampson, 07, 483-489*

Impressions of Oceanographic Research in Europe: A Summary Report

*J. P. Dugan, 08, 545-549*

Ocean-Shelf Coupling and Exchange: A Workshop on Important Ocean Physics Processes at the Shelf Edge

*J. P. Dugan and T. H. Kinder, 08, 549-551*

European Community Autonomous Underwater Vehicle Programs

*J. A. Sampson, 08, 552-554*

## **POLICY**

Support of Basic Science in Ukraine Linked to Country's Economic Survival

*C. Glenday, 03, 213-220*

German S&T Cooperation with Eastern Europe and the Former Soviet Union

*C. Glenday, 05, 323-329*

European Community Programs for S&T Collaboration with Eastern Europe and the Former Soviet Union

*C. Glenday, 05, 330-333*

Austrian Science and Technology Cooperation with Eastern Europe and the Former Soviet Union

*C. Glenday, 06, 413-415*

Science and Technology Reform in Poland

*C. Glenday, 06, 416-421*

French Perspectives on European Scientific Research

*C. Glenday, 07, 489-491*

French Science and Technology Cooperation With Eastern Europe and the Former Soviet Union

*C. Glenday, 07, 491-494*

U.K. Programs for Science and Technology Cooperation With Eastern Europe and the Former Soviet Union

*C. Glenday, 07, 494-496*

New Directions for the Estonian Academy of Sciences and Estonian Universities and Institutes

*F.E. Russell, 09, 608-611*

## **PSYCHOLOGY**

The Twenty-Eighth International Applied Military Psychology Symposium (IAMPS)

*S. C. Collyer and H. W. Sinaiko, 05, 333-344*

Enhancing Performance Under Stress By Information About Its Expected Duration

*S. Preznitz, 05, 345-353*

## **RESEARCH**

The East German Research Landscape in Transition: Information for Scientific Interaction with East Germany, Including Surveys on the Structure of Research in the Federal Republic of Germany

*H. and L. Dolezalek, 02, 83-125*

## **SOLID STATE PHYSICS**

Europe Reclaims Its Historical Cultural Commitment to Scientific Research: Aspects of Solid-State and Semiconductor Physics Research. Part 1.

*N. J. M. Horing, 05, 354-361*

Europe Reclaims Its Historical Cultural Commitment to Scientific Research: Aspects of Solid-State and Semiconductor Physics Research. Part 2.

*N. J. M. Horing, 06, 421-430*

## **THE EMBASSIES: TECHNOLOGY ROUNDUP**

Federal Republic of Germany, 04, 281-286

## 1993 ONR EUROPE REPORTS

ONR Europe Reports provide information that is not appropriate for publication in *ESNIB*, either because of content, length, or distribution limitation. Unless noted, reports are approved for public release; distribution is unlimited. They are available from our London office, address on the inside front cover of this issue. Reports with a "C" suffix discuss European and Middle Eastern conferences; an "R" suffix indicates reports that provide expanded reviews of research or research institutions; a "W" suffix provides abstract compilations from workshop participants.

### UNDERSEA WARFARE

- 93-1-R European Mine Countermeasures  
Technology: A Survey and  
Assessment\*  
*R. Kenneth Lobb*

### RESEARCH POLICY

- 93-2-R The East German Research  
Landscape in Transition. Part A:  
Status and Transition  
*Hans Dolezalek*
- 93-3-R The East German Research  
Landscape in Transition. Part B:  
Non-University Institutes  
*Hans Dolezalek*
- 93-4-R The East German Research  
Landscape in Transition. Part C:  
Research at East German Universities  
*Hans Dolezalek*

### AIR ADVANCED WEAPONS

- 93-5-R European Air Weaponry Technology  
Survey and Assessment Report\*\*  
*James R. Knepshield*

### OCEANOGRAPHY

- 93-6-R Points of Contact for Oceanographic  
Institutes in Europe and Russia  
*John P. Dugan*

### MATERIALS

- 93-7-R Piezoelectric Materials Research in  
Europe  
*CDR John A. Sampson*

### ACOUSTICS

- 93-8-W Structural Acoustics: A Forum for  
Young Investigators  
*Paul E. Barbone*

### ENVIRONMENT

- 93-9-R European Soil Remediation Research  
*Michael Overcash*

\*Distribution authorized to DOD components only; Foreign government information: January 1993. Other requests must be referred to ONR 4533, Arlington, VA 22217-5660.

\*\*Distribution authorized to DOD components only; Foreign government information; 30 August 1993. Other requests must be referred to ONR Europe, PSC 802 Box 39, FPO AE 09499-0700.