

RL-TR-92-237
In-House Report
August 1992

AD-A280 374



ASYMPTOTIC EXPANSIONS FOR A CLASS OF HYPERGEOMETRIC FUNCTIONS

Saba Mudaliar

DTIC
ELECTE
JUN 17 1994
S F D

APPROVED FOR PUBLIC RELEASE; DISTRIBUTION UNLIMITED.

94-18790



DTIC GENERATED BY AUTOMATIC

Rome Laboratory
Air Force Systems Command
Griffiss Air Force Base, NY 13441-5700

94 6 16 065

This report has been reviewed by the Rome Laboratory Public Affairs Office (PA) and is releasable to the National Technical Information Service (NTIS). At NTIS it will be releasable to the general public, including foreign nations.

RL-TR-92-237 has been reviewed and is approved for publication.

APPROVED:



EDWARD E. ALTSHULER
Chief, Applied Electromagnetics Division
Electromagnetics & Reliability Directorate

FOR THE COMMANDER:



JOHN K. SCHINDLER, Director
Electromagnetics & Reliability Directorate

If your address has changed or if you wish to be removed from the Rome Laboratory mailing list, or if the addressee is no longer employed by your organization, please notify RL(ERCE) Hanscom AFB MA 01731-5000. This will assist us in maintaining a current mailing list.

Do not return copies of this report unless contractual obligations or notices on a specific document require that it be returned.

REPORT DOCUMENTATION PAGE			Form Approved OMB No. 0704-0188	
Public reporting burden for this collection of information is estimated to average 1 hour per response, including the time for reviewing instructions, searching existing data sources, gathering and maintaining the data needed, and completing and reviewing the collection of information. Send comments regarding this burden estimate or any other aspect of this collection of information, including suggestions for reducing this burden, to Washington Headquarters Services, Directorate for Information Operations and Reports, 1215 Jefferson Davis Highway, Suite 1204, Arlington, VA 22202-4302, and to the Office of Management and Budget, Paperwork Reduction Project (0704-0188), Washington, DC 20503.				
1. AGENCY USE ONLY (Leave blank)	2. REPORT DATE August 1992	3. REPORT TYPE AND DATES COVERED In-House January 1992-August 1992		
4. TITLE AND SUBTITLE Asymptotic Expansions For A Class Of Hypergeometric Functions			6. FUNDING NUMBERS PE - 61102F PR - 2305 TA - 2305J4 WU - 2305J409	
6. AUTHOR(S) Saba Mudaliar				
7. PERFORMING ORGANIZATION NAME(S) AND ADDRESS(ES) Rome Laboratory / ERCE Hanscom AFB, MA 01731-5000			8. PERFORMING ORGANIZATION REPORT NUMBER RL-TR-92-237	
9. SPONSORING/MONITORING AGENCY NAME(S) AND ADDRESS(ES)			10. SPONSORING/MONITORING AGENCY REPORT NUMBER	
11. SUPPLEMENTARY NOTES				
12a. DISTRIBUTION/AVAILABILITY STATEMENT Approved for Public Release; Distribution Unlimited			12b. DISTRIBUTION CODE	
13. ABSTRACT (Maximum 200 words) The usual power series representations for hypergeometric functions in two variables have a limited range of validity. In particular, they are of little use when the magnitude of one of the variables becomes very large. Using a Barnes-type integral representation and the concept of analytic continuation, the region of utility is extended to the desired domain. The poles that occur in the Barnes-type integral are assumed to be simple. Thus, explicit asymptotic expansions are obtained for each of the fourteen hypergeometric functions that belong to this class.				
14. SUBJECT TERMS Hypergeometric functions Functions of two variables Power series expansions			15. NUMBER OF PAGES 38	
Functions with a large argument Contour integration			16. PRICE CODE	
17. SECURITY CLASSIFICATION OF REPORT Unclassified	18. SECURITY CLASSIFICATION OF THIS PAGE Unclassified	19. SECURITY CLASSIFICATION OF ABSTRACT Unclassified	20. LIMITATION OF ABSTRACT SAR	

Contents

1. INTRODUCTION	1
2. ANALYSIS	2
3. CONCLUSION	29
References	31

Accession For		
NTIS CRA&I		<input checked="" type="checkbox"/>
DTIC TAB		<input type="checkbox"/>
Unannounced		<input type="checkbox"/>
Justification		
By		
Distribution /		
Availability Codes		
Dist	Avail and/or Special	
A-1		

Illustrations

- | | |
|---------------------------------|---|
| 1. Contour of Integration C_+ | 3 |
| 2. Contour of Integration C_- | 8 |

ASYMPTOTIC EXPANSIONS FOR A CLASS OF HYPERGEOMETRIC FUNCTIONS

1. INTRODUCTION

The study of hypergeometric functions is an old one and may be traced back to Gauss. Since then this function has been extensively analyzed and a comprehensive account of all the major results is given by Erdelyi et al [1953]¹. This subject is so rich and colorful that decades of research do not seem to have exhausted interest in it - investigators continue to find numerous applications in various disciplines. It is pleasing to note that most elementary and special functions can be expressed in terms of hypergeometric functions. What is more fascinating is that several obscure integrals have simple representations in terms of hypergeometric functions. Thus, it is still of interest to researchers to explore further the properties of and inter-relations between various hypergeometric functions.

Appell [Appell and Kampé de Fériet, 1926]² extended the notion of hypergeometric function in a single variable to two variables. He defined four types of such functions. Later, Horn [1931]³ discovered a few more and a complete list of all the hypergeometric functions in two variables is given by Erdelyi et al [1953]¹. There are some errors in

Received for Publication 28 August 1992

this list and the corrected versions are given in Srivastava and Karlsson [1985]⁴

In this report we are concerned with the asymptotic series expansions of these hypergeometric functions when the magnitude of one of the variables becomes large. The basic concept is that of analytic continuation using a Barnes-type integral representation.

2. ANALYSIS

We begin by examining a Barnes-type integral suitable for the hypergeometric function under investigation. Depending on the contour of integration we obtain two types of expansions; this leads to the desired representation of the hypergeometric function. Detailed analysis of this procedure is provided for the first hypergeometric function $F_1(\alpha, \beta, \bar{\beta}; \gamma; x, y)$. For the other thirteen hypergeometric functions that belong to this class the discussion is brief since the procedures are similar.

Consider

$$I_+ = \frac{1}{2\pi i} \int_{C_+} \frac{\Gamma(\alpha+m+z)}{\Gamma(\gamma+m+z)} \Gamma(\bar{\beta}+z) \Gamma(-z) (-y)^z dz \quad (1)$$

where C_+ is the semicircular contour on the right hand side (see Figure 1) of the z -plane; $\alpha, \bar{\beta}, \gamma$, and y are complex while m is an integer. As shown in the figure the contour is indented in such a way that the sequence of poles extending to the right ($z = n; n = 0, 1, 2, \dots$) is separated from that extending to the left ($z = -n - \bar{\beta}$;

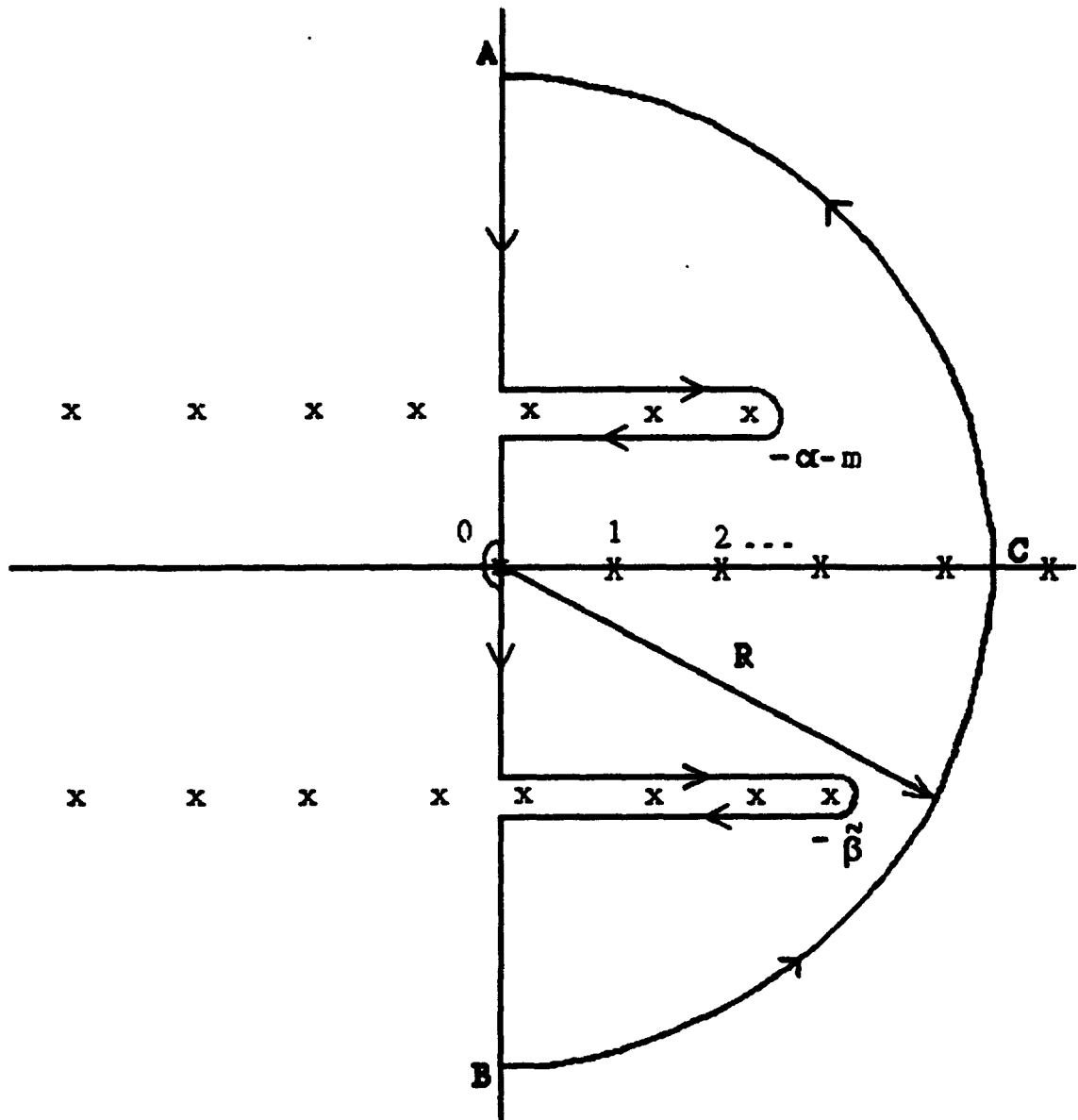

Figure 1. Contour of Integration C_+

$z = -n - \alpha - m$ for $n = 0, 1, 2, \dots$). Let the radius of the semi-circle be R . Also we assume that all the poles are simple.

$$2\pi i I_+ = \int_{AB} + \int_{BCA} = -I + J_+ \quad (2)$$

Consider first

$$J_+ = \int_{-\pi/2}^{\pi/2} \frac{\Gamma(\alpha+m+z)}{\Gamma(\gamma+m+z)} \Gamma(\beta+z) \Gamma(-z) (-y)^z d(\operatorname{Re} i\theta) \quad (3)$$

On using the identity

$$\Gamma(1+z) \Gamma(-z) = -\pi \operatorname{cosec}(\pi z) \quad (4)$$

$$J_+ = \int_{-\pi/2}^{\pi/2} i \operatorname{Re} i\theta (-\pi) \frac{\Gamma(\alpha+m+z) \Gamma(\beta+z)}{\Gamma(\gamma+m+z) \Gamma(1+z)} \operatorname{cosec}(\pi z) (-y)^z d\theta$$

$$\leq \int_{-\pi/2}^{\pi/2} \pi R \left| \frac{\Gamma(\alpha+m+z) \Gamma(\beta+z)}{\Gamma(\gamma+m+z) \Gamma(1+z)} \right| |\operatorname{cosec}(\pi z)| |(-y)^z| d\theta \quad (5)$$

Now the asymptotic form of the gamma function is given as [Abramovitz and Stegun, 1964]³

$$\Gamma(az+b) \sim \sqrt{2\pi} e^{-az} (az)^{az+b-0.5}, \quad |z| \rightarrow \infty, \quad |\arg(z)| < \pi, \quad a > 0 \quad (6)$$

Thus

$$\left| \frac{\Gamma(\alpha+m+z) \Gamma(\bar{\beta}+z)}{\Gamma(\gamma+m+z) \Gamma(1+z)} \right| - R^{\alpha'+\bar{\beta}'-\gamma'-1} \exp \left[-\theta(\alpha''+\bar{\beta}''-\gamma'') \right] \quad (7)$$

where ' and '' denote respectively the real and imaginary parts of a complex quantity. Also

$$\left| \operatorname{cosec}(\pi z) \right| - 2 e^{-\pi |z''|} \quad (8)$$

and

$$\left| (-y)^z \right| - |y|^{z'} e^{-\phi z''} \quad (9)$$

where

$$\phi = \arg(-y) \quad (10)$$

Thus the integrand of Eq. (5) (call it T_1) becomes

$$\begin{aligned} T_1 - & A_1 R^{\alpha'+\bar{\beta}'-\gamma'} |y|^{R \cos \theta} \exp \left\{ -R |\sin \theta| (\pi + \phi) \right\} & 0 < \theta < \pi/2 \\ - & A_1 R^{\alpha'+\bar{\beta}'-\gamma'} |y|^{R \cos \theta} \exp \left\{ -R |\sin \theta| (\pi - \phi) \right\} & 0 > \theta > -\pi/2 \end{aligned} \quad (11)$$

where A_1 is independent of R .

Now as $R \rightarrow \infty$

$$T_1 \rightarrow 0 \quad \text{if } |y| < 1 \text{ and } |\phi| < \pi \quad (12)$$

Also as $R \rightarrow \infty$

$$I = \int_{-i\infty}^{i\infty} dz \frac{\Gamma(\alpha+m+z)}{\Gamma(\gamma+m+z)} \Gamma(\bar{\beta}+z) \Gamma(-z) (-y)^z \quad (13)$$

Evaluating Eq. (1) by the Cauchy integral theorem

$$\begin{aligned} I_+ &= \sum_{n=0}^{\infty} \text{Residue at } z = n \\ &= \sum_{n=0}^{\infty} \frac{\Gamma(\alpha+m+n)}{\Gamma(\gamma+m+n)} \Gamma(\bar{\beta}+n) \frac{(-1)^{n-1}}{n!} (-y)^n \\ &= - \frac{\Gamma(\alpha) \Gamma(\bar{\beta})}{\Gamma(\gamma)} \sum_{n=0}^{\infty} \frac{(\alpha)_{m+n}}{(\gamma)_{m+n}} (\bar{\beta})_n \frac{y^n}{n!} \end{aligned} \quad (14)$$

where we use the Pochhammer symbol

$$(\alpha)_n = \frac{\Gamma(\alpha+n)}{\Gamma(\alpha)} \quad (15)$$

Thus from Eqs. (14), (13), (2), (12)

$$I = -2\pi i \frac{\Gamma(\alpha) \Gamma(\bar{\beta})}{\Gamma(\gamma)} \sum_{n=0}^{\infty} \frac{(\alpha)_{m+n}}{(\gamma)_{m+n}} (\bar{\beta})_n \frac{y^n}{n!} \quad (16)$$

Consider now

$$I_- = \frac{1}{2\pi i} \int_{C_-} \frac{\Gamma(\alpha+m+z)}{\Gamma(\gamma+m+z)} \Gamma(\bar{\beta}+z) \Gamma(-z) (-y)^z dz \quad (17)$$

where C_- is the semicircular contour (AODB) of radius R in the left half of the z -plane (see Figure 2).

As before

$$2\pi i I_- = -I - J_- \quad (18)$$

where

$$J_- = \int_{\pi/2}^{3\pi/2} \frac{\Gamma(\alpha+m+z)}{\Gamma(\gamma+m+z)} \Gamma(\bar{\beta}+z) \Gamma(-z) (-y)^z d(\text{Re } i\theta) \quad (19)$$

Using the identity of Eq. (4)

$$\begin{aligned} J_- &= \int_{\pi/2}^{3\pi/2} i \text{Re } i\theta \frac{\Gamma(1-\gamma-m-z)}{\pi \text{cosec}[\pi(\gamma+m+z)]} \\ &\quad \cdot \left| \frac{\text{cosec}[\pi(\alpha+m+z)] \text{cosec}[\pi(\bar{\beta}+z)]}{\text{cosec}[\pi(\gamma+m+z)]} \right| |(-y)^z| d\theta \\ &\leq \int_{\pi/2}^{3\pi/2} R\pi \left| \frac{\Gamma(1-\gamma-m-z) \Gamma(-z)}{\Gamma(1-\alpha-m-z) \Gamma(1-\bar{\beta}-z)} \right| \\ &\quad \cdot \frac{\pi \text{cosec}[\pi(\beta+z)]}{\Gamma(1-\bar{\beta}-z)} \frac{\pi \text{cosec}[\pi(\alpha+m+z)]}{\Gamma(1-\alpha-m-z)} \Gamma(-z) (-y)^z d\theta \end{aligned} \quad (20)$$

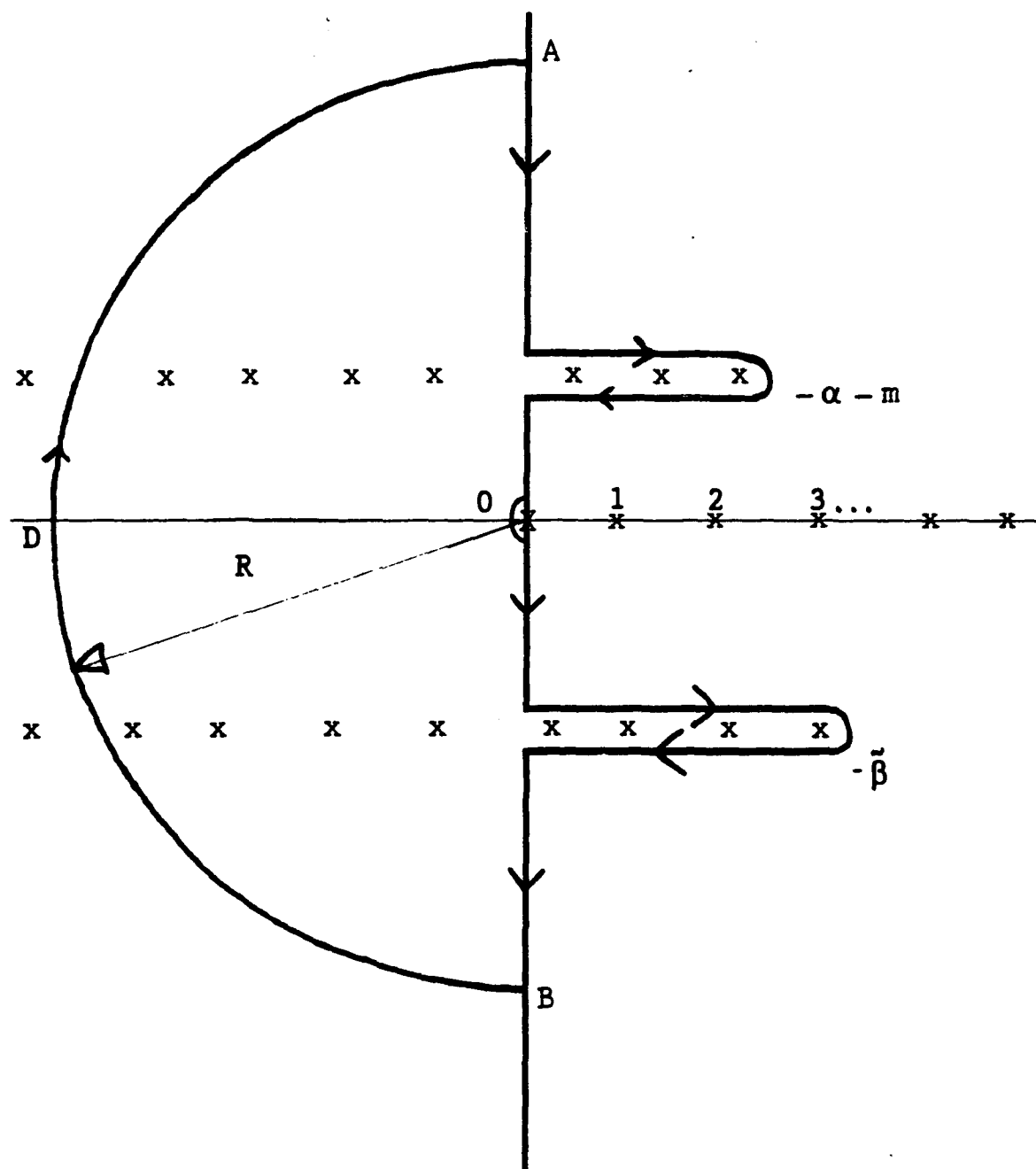

Figure 2. Contour of Integration C.

and since

$$\left| \Gamma(a-z) \right| - \sqrt{2\pi} e^{-z'} R^{a'-z'} R^{-1/2} \exp[-\theta(a''-z'')] , \quad |\arg(z)| > 0 \quad (21)$$

$$\left| \frac{\Gamma(1-\gamma-m-z) \Gamma(-z)}{\Gamma(1-\alpha-m-z) \Gamma(1-\bar{\beta}-z)} \right| - R^{\alpha'+\bar{\beta}'-\gamma'-1} \exp[-\theta(\alpha''+\beta''-\gamma'')] , \quad |\arg(z)| > 0 \quad (22)$$

and

$$\left| \frac{\operatorname{cosec}[\pi(\alpha+m+z)] \operatorname{cosec}[\pi(\bar{\beta}+z)]}{\operatorname{cosec}[\pi(\gamma+m+z)]} \right| - 2 e^{-\pi|z''|} , \quad (23)$$

thus T_2 . the integrand in Eq. (19) is given as

$$\begin{aligned} T_2 &= A_2 R^{\alpha'+\bar{\beta}'-\gamma'} |y|^{-R|\cos\theta|} \exp\left\{ -R|\sin\theta|(\pi+\phi) \right\} \quad \pi/2 < \theta < \pi \\ &- A_2 R^{\alpha'+\bar{\beta}'-\gamma'} |y|^{-R|\cos\theta|} \exp\left\{ -R|\sin\theta|(\pi-\phi) \right\} \quad \pi < \theta < 3\pi/2 \end{aligned} \quad (24)$$

where A_2 is independent of R .

It is clear then that as $R \rightarrow \infty$

$$T_2 \rightarrow 0 \quad \text{if } |y| > 1 \text{ and } |\arg(-y)| < \pi \quad (25)$$

Evaluating Eq. (19) by the Cauchy integral theorem

$$\begin{aligned}
 I_- &= - \sum_{n=0}^{\infty} \text{Residue at } z = -n-\alpha-m \\
 &\quad - \sum_{n=0}^{\infty} \text{Residue at } z = -n-\bar{\beta}
 \end{aligned} \tag{26}$$

From Eqs. (26), (25), (20) and (18)

$$\begin{aligned}
 I &= \sum_{n=0}^{\infty} \text{Residue at } z = -n-\alpha-m \\
 &\quad + \sum_{n=0}^{\infty} \text{Residue at } z = -n-\bar{\beta} \quad \text{if } |y| > 1 \text{ and } |\arg(-y)| < \pi
 \end{aligned} \tag{27}$$

Thus for $|y| > 1$ we may analytically continue the RHS of Eq. (16) to the RHS of Eq. (27) as follows.

$$\begin{aligned}
 &\frac{\Gamma(\alpha) \Gamma(\bar{\beta})}{\Gamma(\gamma)} \sum_{n=0}^{\infty} \frac{(\alpha)_{m+n}}{(\gamma)_{m+n}} (\bar{\beta})_n \frac{y^n}{n!} \\
 &= \sum_{n=0}^{\infty} \text{Residue at } z = -n-\alpha-m \\
 &\quad + \sum_{n=0}^{\infty} \text{Residue at } z = -n-\bar{\beta} ; \quad |y| > 1 \text{ and } |\arg(-y)| < \pi
 \end{aligned} \tag{28}$$

Residue at $z = -n-\alpha$

$$\begin{aligned}
 &= - \frac{(-1)^n}{n!} \frac{\Gamma(\bar{\beta}-\alpha-m-n)}{\Gamma(\gamma-\alpha-n)} \Gamma(\alpha+m+n) (-y)^{-m-n-\alpha} \\
 &= - \frac{(-1)^{m+n}}{n!} \frac{(\alpha)_{m+n} (1+\alpha-\gamma)_n}{(1+\alpha-\bar{\beta})_{m+n}} \frac{\Gamma(\alpha) \Gamma(\bar{\beta}-\alpha)}{\Gamma(\gamma-\alpha)} (-y)^{-m-n-\alpha} \quad (29)
 \end{aligned}$$

Residue at $z = -n-\bar{\beta}$

$$\begin{aligned}
 &= - \frac{\Gamma(\alpha-\bar{\beta}+m-n)}{\Gamma(\gamma-\bar{\beta}+m-n)} \Gamma(\bar{\beta}+n) \frac{(-1)^n}{n!} (-y)^{-n-\bar{\beta}} \\
 &= - \frac{(\alpha-\bar{\beta})_{m-n}}{(\gamma-\bar{\beta})_{m-n}} (\bar{\beta})_n \frac{\Gamma(\bar{\beta}) \Gamma(\alpha-\bar{\beta})}{\Gamma(\gamma-\bar{\beta})} \frac{(-1)^n}{n!} (-y)^{-n-\bar{\beta}} \quad (30)
 \end{aligned}$$

Using Eqs. (29) and (30) in Eq. (28).

$$\begin{aligned}
 &\frac{\Gamma(\alpha) \Gamma(\bar{\beta})}{\Gamma(\gamma)} \sum_{n=0}^{\infty} \frac{(\alpha)_{m+n}}{(\gamma)_{m+n}} (\bar{\beta})_n \frac{y^n}{n!} \\
 &= - \frac{\Gamma(\alpha) \Gamma(\bar{\beta}-\alpha)}{\Gamma(\gamma-\alpha)} \sum_{n=0}^{\infty} \frac{(\alpha)_{m+n} (1+\alpha-\gamma)_n}{(1+\alpha-\bar{\beta})_{m+n}} \frac{(-1)^{m+n}}{n!} (-y)^{-m-n-\alpha} \\
 &\quad - \frac{\Gamma(\bar{\beta}) \Gamma(\alpha-\bar{\beta})}{\Gamma(\gamma-\bar{\beta})} \sum_{n=0}^{\infty} \frac{(\alpha-\bar{\beta})_{m-n}}{(\gamma-\bar{\beta})_{m-n}} (\bar{\beta})_n \frac{(-1)^n}{n!} (-y)^{-n-\bar{\beta}} \quad (31)
 \end{aligned}$$

Multiplying both sides of Eq. (31) by $(\beta_m) \frac{x^m}{m!}$ and summing over $m = 0$ to ∞ we get

$$\begin{aligned}
 & \frac{\Gamma(\alpha) \Gamma(\bar{\beta})}{\Gamma(\gamma)} \sum_{m=0}^{\infty} \sum_{n=0}^{\infty} \frac{(\alpha)_{m+n}}{(\gamma)_{m+n}} (\bar{\beta})_n (\beta)_m \frac{x^m}{m!} \frac{y^n}{n!} \\
 &= - \frac{\Gamma(\alpha) \Gamma(\bar{\beta}-\alpha)}{\Gamma(\gamma-\alpha)} (-y)^{-\alpha} \\
 & \quad \cdot \sum_{m=0}^{\infty} \sum_{n=0}^{\infty} \frac{(\beta)_m (\alpha)_{m+n} (1+\alpha-\gamma)_n}{(1+\alpha-\bar{\beta})_{m+n}} \frac{(x/y)^m}{m!} \frac{(1/y)^n}{n!} \\
 &= - \frac{\Gamma(\bar{\beta}) \Gamma(\alpha-\bar{\beta})}{\Gamma(\gamma-\bar{\beta})} (-y)^{-\bar{\beta}} \\
 & \quad \cdot \sum_{m=0}^{\infty} \sum_{n=0}^{\infty} (\beta)_m \frac{(\alpha-\bar{\beta})_{m-n}}{(\gamma-\bar{\beta})_{m-n}} (\bar{\beta})_n \frac{x^m}{m!} \frac{(1/y)^n}{n!}
 \end{aligned} \tag{32}$$

It may be noted that in our derivation m has been implicitly assumed to be a finite integer. But since the series in Eq.(32) is uniformly convergent we may let m become arbitrarily large.

The formal definition of the hypergeometric function $F_1(\alpha, \beta, \bar{\beta}; \gamma; x, y)$ is given as [Erdelyi et al. 1953]¹

$$F_1(\alpha, \beta, \bar{\beta}; \gamma; x, y)$$

$$= \sum_{m=0}^{\infty} \sum_{n=0}^{\infty} \frac{(\beta)_m (\alpha)_{m+n} (\bar{\beta})_n}{(\gamma)_{m+n}} \frac{x^m}{m!} \frac{y^n}{n!} \quad (33)$$

Thus, we have the desired expansion for $F_1(\alpha, \beta, \bar{\beta}; \gamma; x, y)$ when $|x| < 1$ and $|y| > 1$

$$F_1(\alpha, \beta, \bar{\beta}; \gamma; x, y)$$

$$= - \frac{\Gamma(\bar{\beta}-\alpha) \Gamma(\gamma)}{\Gamma(\gamma-\alpha) \Gamma(\bar{\beta})} (-y)^{-\alpha}$$

$$+ \sum_{m=0}^{\infty} \sum_{n=0}^{\infty} \frac{(\beta)_m (\alpha)_{m+n} (1+\alpha-\gamma)_n}{(1+\alpha-\bar{\beta})_{m+n}} \frac{(x/y)^m}{m!} \frac{(1/y)^n}{n!}$$

$$- \frac{\Gamma(\alpha-\bar{\beta}) \Gamma(\gamma)}{\Gamma(\alpha) \Gamma(\gamma-\bar{\beta})} (-y)^{-\bar{\beta}}$$

$$+ \sum_{m=0}^{\infty} \sum_{n=0}^{\infty} (\beta)_m \frac{(\alpha-\bar{\beta})_{m-n}}{(\gamma-\bar{\beta})_{m-n}} (\bar{\beta})_n \frac{x^m}{m!} \frac{(1/y)^n}{n!}$$

(34)

where $|\arg(-y)| < \pi$. The above procedure may be adopted to obtain asymptotic expansions for other hypergeometric functions belonging to this class. To obtain the expansion for $F_2(\alpha, \beta, \bar{\beta}; \gamma, \bar{\gamma}; x, y)$ we consider

$$I_+ = \frac{1}{2\pi i} \int_{C_+} \frac{\Gamma(\alpha+m+z)}{\Gamma(\bar{\gamma}+z)} \Gamma(\bar{\beta}+z) \Gamma(-z) (-y)^z dz \quad (35)$$

where C_+ is as before a semicircular contour to the right of the z -plane. On evaluating Eq. (35) we obtain for $|y| < 1$ and $|\arg(-y)| < \pi$.

$$\begin{aligned}
 I &= \int_{-i\infty}^{i\infty} \frac{\Gamma(\alpha+m+z)}{\Gamma(\bar{\gamma}+z)} \Gamma(\bar{\beta}+z) \Gamma(-z) (-y)^z dz \\
 &= \frac{\Gamma(\alpha) \Gamma(\bar{\beta})}{\Gamma(\bar{\gamma})} \sum_{n=0}^{\infty} \frac{(\alpha)_{m+n} (\bar{\beta})_n}{(\bar{\gamma})_n} \frac{(-1)^n}{n!} (-y)^n
 \end{aligned} \tag{36}$$

Next consider I_- which is the same integral as in Eq. (35) but along the contour C_- . This leads to

$$\begin{aligned}
 I &= - \frac{\Gamma(\alpha) \Gamma(\bar{\beta}-\alpha)}{\Gamma(\bar{\gamma}-\alpha)} (-y)^{-\alpha} \\
 &\quad \cdot \sum_{n=0}^{\infty} \frac{(\alpha)_{m+n} (1+\alpha-\bar{\gamma})_{m+n}}{(1+\alpha-\bar{\beta})_{m+n}} (-1)^m y^{-m} \frac{y^{-n}}{n!} \\
 &= - \frac{\Gamma(\bar{\beta}) \Gamma(\alpha-\bar{\beta})}{\Gamma(\bar{\gamma}-\bar{\beta})} (-y)^{-\bar{\beta}} \\
 &\quad \cdot \sum_{n=0}^{\infty} (\alpha-\bar{\beta})_{m-n} (1+\bar{\beta}-\bar{\gamma})_n (\bar{\beta})_n (-1)^n \frac{y^{-n}}{n!}
 \end{aligned} \tag{37}$$

if $|y| > 1$ and $|\arg(-y)| < \pi$.

Thus, by analytic continuation

$$\begin{aligned}
 & \frac{\Gamma(\alpha) \Gamma(\bar{\beta})}{\Gamma(\bar{\gamma})} \sum_{n=0}^{\infty} \frac{(\alpha)_{m+n} (\bar{\beta})_n}{(\bar{\gamma})_n} \frac{(-1)^n}{n!} (-y)^n \\
 & = - \frac{\Gamma(\alpha) \Gamma(\bar{\beta}-\alpha)}{\Gamma(\bar{\gamma}-\alpha)} (-y)^{-\alpha} \\
 & \quad \cdot \sum_{n=0}^{\infty} \frac{(\alpha)_{m+n} (1+\alpha-\bar{\gamma})_{m+n}}{(1+\alpha-\bar{\beta})_{m+n}} (-1)^m y^{-m} \frac{y^{-n}}{n!} \\
 & = - \frac{\Gamma(\bar{\beta}) \Gamma(\alpha-\bar{\beta})}{\Gamma(\bar{\gamma}-\bar{\beta})} (-y)^{-\bar{\beta}} \\
 & \quad \cdot \sum_{n=0}^{\infty} (\alpha-\bar{\beta})_{m-n} (1+\bar{\beta}-\bar{\gamma})_n (\bar{\beta})_n (-1)^n \frac{y^{-n}}{n!} ;
 \end{aligned}$$

$$|\arg(-y)| < \pi$$

(38)

Multiplying Eq. (38) by $\frac{(\beta)_m}{(\gamma)_m} \frac{x^m}{m!}$ and summing the result over $m = 0$

to ∞ we get the desired asymptotic expansion.

$$F_2(\alpha, \beta, \bar{\beta}; \gamma, \bar{\gamma}; x, y)$$

$$= \sum_{m=0}^{\infty} \sum_{n=0}^{\infty} \frac{(\alpha)_{m+n} (\beta)_m (\bar{\beta})_n}{(\gamma)_m (\bar{\gamma})_n} \frac{x^m}{m!} \frac{y^n}{n!}$$

$$= - \frac{\Gamma(\bar{\beta}-\alpha) \Gamma(\bar{\gamma})}{\Gamma(\bar{\gamma}-\alpha) \Gamma(\bar{\beta})} (-y)^{-\alpha}$$

$$+ \sum_{m=0}^{\infty} \sum_{n=0}^{\infty} \frac{(\beta)_m (\alpha)_{m+n} (1+\alpha-\bar{\gamma})_{m+n}}{(\gamma)_m (1+\alpha-\bar{\beta})_{m+n}} (-1)^m \frac{(x/y)^m}{m!} \frac{(1/y)^n}{n!}$$

$$- \frac{\Gamma(\alpha-\bar{\beta}) \Gamma(\bar{\gamma})}{\Gamma(\bar{\gamma}-\bar{\beta}) \Gamma(\alpha)} (-y)^{-\bar{\beta}}$$

$$+ \sum_{m=0}^{\infty} \sum_{n=0}^{\infty} \frac{(\beta)_m (\alpha-\bar{\beta})_{m-n} (1+\bar{\beta}-\bar{\gamma})_n (\bar{\beta})_n}{(\gamma)_m} (-1)^n \frac{x^m}{m!} \frac{(1/y)^n}{n!};$$

$$|y| > 1; |x| < 1; |\arg(-y)| < \pi$$

(39)

The conditions that appear in Eq. (39) occur in expansions of all the hypergeometric functions that we are going to consider. Hence, for the sake of brevity we shall hereafter omit these conditions.

Next consider

$$I = \sum_{m=0}^{\infty} (\alpha)_m (\beta)_m \frac{x^m}{m!} \cdot \frac{1}{2\pi i} \int_{-i\infty}^{i\infty} \frac{\Gamma(\bar{\alpha}+z)}{\Gamma(\gamma+m+z)} \Gamma(\bar{\beta}+z) \Gamma(-z) (-y)^z dz \quad (40)$$

Closing the contour of integration by semicircles to the right and then to the left of the z-plane and evaluating, we obtain as before

$$F_3(\alpha, \bar{\alpha}, \beta, \bar{\beta}; \gamma; x, y)$$

$$\begin{aligned} &= \sum_{m=0}^{\infty} \sum_{n=0}^{\infty} \frac{(\alpha)_m (\bar{\alpha})_n}{(\gamma)_{m+n}} (\beta)_m (\bar{\beta})_n \frac{x^m}{m!} \frac{y^n}{n!} \\ &= - \frac{\Gamma(\bar{\beta}-\bar{\alpha}) \Gamma(\gamma)}{\Gamma(\gamma-\bar{\alpha}) \Gamma(\bar{\beta})} (-y)^{-\bar{\alpha}} \\ &\quad \cdot \sum_{m=0}^{\infty} \sum_{n=0}^{\infty} \frac{(\alpha)_m (\beta)_m (\bar{\alpha})_n}{(\gamma-\bar{\alpha})_{m-n} (1+\bar{\alpha}-\bar{\beta})_n} (-1)^n \frac{x^m}{m!} \frac{(1/y)^n}{n!} \\ &= - \frac{\Gamma(\bar{\alpha}-\bar{\beta}) \Gamma(\gamma)}{\Gamma(\gamma-\bar{\beta}) \Gamma(\bar{\alpha})} (-y)^{-\bar{\beta}} \\ &\quad \cdot \sum_{m=0}^{\infty} \sum_{n=0}^{\infty} \frac{(\alpha)_m (\beta)_m (\bar{\beta})_n}{(\gamma-\bar{\beta})_{m-n} (1+\bar{\beta}-\bar{\alpha})_n} (-1)^n \frac{x^m}{m!} \frac{(1/y)^n}{n!} \end{aligned}$$

(41)

To obtain an asymptotic expansion for

$$F_4(\alpha, \beta; \gamma, \bar{\gamma}; x, y) = \sum_{m=0}^{\infty} \sum_{n=0}^{\infty} \frac{(\alpha)_{m+n} (\beta)_{m+n}}{(\gamma)_m (\bar{\gamma})_n} \frac{x^m}{m!} \frac{y^n}{n!} \quad (42)$$

we consider

$$\begin{aligned} I &= \frac{\Gamma(\bar{\gamma})}{\Gamma(\alpha) \Gamma(\beta)} \sum_{m=0}^{\infty} \frac{1}{(\gamma)_m} \frac{x^m}{m!} \\ &\cdot \frac{1}{2\pi i} \int_{-i\infty}^{i\infty} \frac{\Gamma(\alpha+m+z)}{\Gamma(\bar{\gamma}+z)} \Gamma(\beta+m+z) \Gamma(-z) (-y)^z dz \end{aligned} \quad (43)$$

This leads to the desired expansion for F_4 .

$$F_4(\alpha, \beta; \gamma, \bar{\gamma}; x, y)$$

$$\begin{aligned} &= - \frac{\Gamma(\beta-\alpha) \Gamma(\bar{\gamma})}{\Gamma(\bar{\gamma}-\alpha) \Gamma(\beta)} (-y)^{-\alpha} \\ &\cdot \sum_{m=0}^{\infty} \sum_{n=0}^{\infty} \frac{(\alpha)_{m+n} (1+\alpha-\bar{\gamma})_{m+n}}{(\gamma)_m (1+\alpha-\beta)_n} \frac{(x/y)^m}{m!} \frac{(1/y)^n}{n!} \\ &- \frac{\Gamma(\alpha-\beta) \Gamma(\bar{\gamma})}{\Gamma(\bar{\gamma}-\beta) \Gamma(\alpha)} (-y)^{-\beta} \\ &\cdot \sum_{m=0}^{\infty} \sum_{n=0}^{\infty} \frac{(\beta)_{m+n} (1+\beta-\bar{\gamma})_{m+n}}{(\gamma)_m (1+\beta-\alpha)_n} \frac{(x/y)^m}{m!} \frac{(1/y)^n}{n!} \end{aligned} \quad (44)$$

Next, consider

$$I = \frac{1}{\Gamma(\alpha) \Gamma(\beta)} \sum_{m=0}^{\infty} (\bar{\beta})_m \frac{x^m}{m!} \Gamma(1-\bar{\beta}-m)$$

$$\cdot \frac{1}{2\pi i} \int_{-i\infty}^{i\infty} \frac{\Gamma(\alpha+m+z)}{\Gamma(1-\bar{\beta}-m+z)} \Gamma(\beta-m+z) \Gamma(-z) y^z dz \quad (45)$$

This leads to

$$G_1(\alpha, \beta, \bar{\beta}; x, y)$$

$$= \sum_{m=0}^{\infty} \sum_{n=0}^{\infty} (\alpha)_{m+n} (\beta)_{n-m} (\bar{\beta})_{m-n} \frac{x^m}{m!} \frac{y^n}{n!}$$

$$= - \frac{\Gamma(\beta-\alpha) \Gamma(1-\bar{\beta})}{\Gamma(1-\bar{\beta}-\alpha) \Gamma(\beta)} y^{-\alpha}$$

$$\cdot \sum_{m=0}^{\infty} \sum_{n=0}^{\infty} \frac{(\alpha)_{m+n} (\bar{\beta}+\alpha)_{2m+n}}{(1+\alpha-\beta)_{2m+n}} (-1)^{m+n} \frac{(x/y)^m}{m!} \frac{(1/y)^n}{n!}$$

$$- \frac{\Gamma(\beta+\alpha) \Gamma(1-\bar{\beta})}{\Gamma(1-\bar{\beta}-\beta) \Gamma(\alpha)} y^{-\beta}$$

$$\cdot \sum_{m=0}^{\infty} \sum_{n=0}^{\infty} (\alpha+\beta)_{2m-n} (\beta)_{n-m} (\beta+\bar{\beta})_n (-1)^m \frac{(xy)^m}{m!} \frac{(1/y)^n}{n!}$$

(46)

Consider next

$$I = \sum_{m=0}^{\infty} (\alpha)_m \frac{(-x)^m}{m!} \cdot \frac{1}{2\pi i} \int_{-i\infty}^{i\infty} \frac{\Gamma(\bar{\alpha}+z)}{\Gamma(1-\bar{\beta}-m+z)} \Gamma(\beta-m+z) \Gamma(-z) y^z dz \quad (47)$$

This leads to

$$G_2(\alpha, \bar{\alpha}, \beta, \bar{\beta}; x, y)$$

$$\begin{aligned} &= \sum_{m=0}^{\infty} \sum_{n=0}^{\infty} (\alpha)_m (\bar{\alpha})_n (\beta)_{n-m} (\bar{\beta})_{m-n} \frac{x^m}{m!} \frac{y^n}{n!} \\ &= - \frac{\Gamma(\beta-\bar{\alpha}) \Gamma(1-\bar{\beta})}{\Gamma(1-\bar{\beta}-\bar{\alpha}) \Gamma(\beta)} y^{-\bar{\alpha}} \\ &\quad \cdot \sum_{m=0}^{\infty} \sum_{n=0}^{\infty} \frac{(\bar{\alpha}+\bar{\beta})_{m+n}}{(1+\bar{\alpha}-\beta)_{m+n}} (\alpha)_m (\bar{\alpha})_n (-1)^{m+n} \frac{x^m}{m!} \frac{(1/y)^n}{n!} \\ &= - \frac{\Gamma(\bar{\alpha}-\beta) \Gamma(1-\bar{\beta})}{\Gamma(1-\bar{\beta}-\beta) \Gamma(\bar{\alpha})} y^{-\beta} \\ &\quad \cdot \sum_{m=0}^{\infty} \sum_{n=0}^{\infty} \frac{(\bar{\alpha}-\beta)_{m-n}}{(1-\beta)_{m-n}} (\alpha)_m (\beta+\bar{\beta})_n (-1)^n \frac{(xy)^m}{m!} \frac{(1/y)^n}{n!} \quad (48) \end{aligned}$$

Next we seek an expansion for

$$G_3(\alpha, \bar{\alpha}; x, y) = \sum_{m=0}^{\infty} \sum_{n=0}^{\infty} (\alpha)_{2n-m} (\bar{\alpha})_{2m-n} \frac{x^m}{m!} \frac{y^n}{n!} \quad (49)$$

To this end we consider

$$\begin{aligned} I &= \sum_{m=0}^{\infty} \frac{(\bar{\alpha})_{2m}}{(1-\alpha)_m} \frac{(-x)^m}{m!} \frac{\Gamma(1-\bar{\alpha}-2m)}{\Gamma[.5(\alpha-m)] \Gamma[.5(\alpha-m)+.5]} \\ &\cdot \frac{1}{2\pi i} \int_{-i\infty}^{i\infty} \frac{\Gamma[.5(\alpha-m)+z]}{\Gamma(1-\bar{\alpha}-2m+z)} \Gamma[.5(\alpha-m)+.5+z] \Gamma(-z) (-y)^z dz \quad (50) \end{aligned}$$

whence we obtain

$$\begin{aligned} G_3(\alpha, \bar{\alpha}; x, y) &= (-y)^{-.5\alpha} \sum_{m=0}^{\infty} \sum_{n=0}^{\infty} \frac{(\bar{\alpha})_{2m} (.5\alpha-.5m)_n}{(1-\alpha)_m} \\ &\cdot \frac{\Gamma(1-\bar{\alpha}-2m) \Gamma(.5-n)}{\Gamma[.5(\alpha-m+1)] \Gamma(1-\bar{\alpha}-.5\alpha-1.5m-n)} \frac{(ix/y)^m}{m!} \frac{(1/y)^n}{n!} \\ &- (-y)^{-.5(1+\alpha)} \sum_{m=0}^{\infty} \sum_{n=0}^{\infty} \frac{(\bar{\alpha})_{2m} (.5\alpha-.5m+.5)_n}{(1-\alpha)_m} \\ &\cdot \frac{\Gamma(1-\bar{\alpha}-2m) \Gamma(.5-n)}{\Gamma[.5(\alpha-m)] \Gamma(.5-\bar{\alpha}-.5\alpha-1.5m-n)} \frac{(ix/y)^m}{m!} \frac{(1/y)^n}{n!} \quad (51) \end{aligned}$$

$$H_1(\alpha, \beta, \gamma; x, y) = \sum_{m=0}^{\infty} \sum_{n=0}^{\infty} \frac{(\alpha)_{m+n}}{(\delta)_m} (\beta)_{m+n} (\gamma)_n \frac{x^m}{m!} \frac{y^n}{n!} \quad (52)$$

is our next function. So we consider

$$I = \sum_{m=0}^{\infty} \frac{1}{(\delta)_m} \frac{(-x)^m}{m!} \\ \cdot \frac{1}{2\pi i} \int_{-i\infty}^{i\infty} \frac{\Gamma(\gamma+z)}{\Gamma(1-\alpha-m+z)} \Gamma(\beta+m+z) \Gamma(-z) y^z dz \quad (53)$$

and we obtain

$$H_1(\alpha, \beta, \gamma; x, y) \\ = - \frac{\Gamma(1-\alpha) \Gamma(\gamma-\beta)}{\Gamma(1-\beta-\alpha) \Gamma(\gamma)} y^{-\beta} \\ \cdot \sum_{m=0}^{\infty} \sum_{n=0}^{\infty} \frac{(\alpha+\beta)_{2m+n} (\beta)_{m+n}}{(1+\beta-\gamma)_{m+n} (\delta)_m} (-1)^n \frac{(x/y)^m}{m!} \frac{(1/y)^n}{n!} \\ - \frac{\Gamma(1-\alpha) \Gamma(\beta-\gamma)}{\Gamma(1-\alpha-\gamma) \Gamma(\beta)} y^{-\gamma} \\ \cdot \sum_{m=0}^{\infty} \sum_{n=0}^{\infty} (\alpha+\gamma)_{m+n} (\beta-\gamma)_{m-n} \frac{(\gamma)_n}{(\delta)_m} \frac{(x)^m}{m!} \frac{(1/y)^n}{n!} \quad (54)$$

Our next function is

$$H_2(\alpha, \beta, \gamma, \delta; \epsilon; x, y) = \sum_{m=0}^{\infty} \sum_{n=0}^{\infty} \frac{(\alpha)_{m-n}}{(\epsilon)_m} (\beta)_m (\gamma)_n (\delta)_n \frac{x^m}{m!} \frac{y^n}{n!} \quad (55)$$

On considering

$$I = \sum_{m=0}^{\infty} \frac{(\alpha)_m (\beta)_m}{(\epsilon)_m} \frac{(x)^m}{m!} \frac{\Gamma(1-\alpha-m)}{\Gamma(\gamma) \Gamma(\delta)}$$

$$\cdot \frac{1}{2\pi i} \int_{-i\infty}^{i\infty} \frac{\Gamma(\gamma+z)}{\Gamma(1-\alpha-m+z)} \Gamma(\delta+z) \Gamma(-z) y^z dz \quad (56)$$

we obtain

$$H_2(\alpha, \beta, \gamma, \delta; \epsilon; x, y)$$

$$= - \frac{\Gamma(1-\alpha) \Gamma(\delta-\gamma)}{\Gamma(1-\alpha-\gamma) \Gamma(\delta)} y^{-\gamma}$$

$$\cdot \sum_{m=0}^{\infty} \sum_{n=0}^{\infty} \frac{(\alpha+\gamma)_{m+n} (\beta)_m (\gamma)_n}{(1+\gamma-\delta)_n (\epsilon)_m} (-1)^n \frac{(x)^m}{m!} \frac{(1/y)^n}{n!}$$

$$- \frac{\Gamma(1-\alpha) \Gamma(\gamma-\delta)}{\Gamma(1-\alpha-\delta) \Gamma(\gamma)} y^{-\delta}$$

$$\cdot \sum_{m=0}^{\infty} \sum_{n=0}^{\infty} \frac{(\beta)_m (\alpha+\delta)_{m+n} (\delta)_n}{(\epsilon)_m (1+\delta-\gamma)_n} (-1)^n \frac{(x)^m}{m!} \frac{(1/y)^n}{n!}$$

(57)

The next function is

$$H_3(\alpha, \beta; \gamma; x, y) = \sum_{m=0}^{\infty} \sum_{n=0}^{\infty} \frac{(\alpha)_{2m+n} (\beta)_n}{(\gamma)_{m+n}} \frac{x^m}{m!} \frac{y^n}{n!} \quad (58)$$

On considering

$$I = \frac{\Gamma(\gamma)}{\Gamma(\alpha) \Gamma(\beta)} \sum_{m=0}^{\infty} \frac{(x)^m}{m!} \\ \cdot \frac{1}{2\pi i} \int_{-i\infty}^{i\infty} \frac{\Gamma(\alpha+2m+z)}{\Gamma(\gamma+m+z)} \Gamma(\beta+z) \Gamma(-z) (-y)^z dz \quad (59)$$

we obtain the desired expansion

$$H_3(\alpha, \beta; \gamma; x, y) \\ = - \frac{\Gamma(\beta-\alpha) \Gamma(\gamma)}{\Gamma(\beta) \Gamma(\gamma-\alpha)} (-y)^{-\alpha} \\ \cdot \sum_{m=0}^{\infty} \sum_{n=0}^{\infty} \frac{(\alpha)_{2m+n} (1+\alpha-\gamma)_{m+n}}{(1+\alpha-\beta)_{2m+n}} (-1)^m \frac{(x/y^2)^m}{m!} \frac{(1/y)^n}{n!} \\ - \frac{\Gamma(\alpha-\beta) \Gamma(\gamma)}{\Gamma(\alpha) \Gamma(\gamma-\beta)} (-y)^{-\beta} \\ \cdot \sum_{m=0}^{\infty} \sum_{n=0}^{\infty} \frac{(\beta)_n (\alpha-\beta)_{2m-n}}{(\gamma-\beta)_{m-n}} \frac{(x)^m}{m!} \frac{(1/y)^n}{n!} \quad (60)$$

The next function is

$$H_4(\alpha, \beta; \gamma, \delta; x, y) = \sum_{m=0}^{\infty} \sum_{n=0}^{\infty} \frac{(\alpha)_{2m+n} (\beta)_n}{(\gamma)_m (\delta)_n} \frac{x^m}{m!} \frac{y^n}{n!} \quad (61)$$

On considering

$$I = \frac{\Gamma(\delta)}{\Gamma(\beta)} \sum_{m=0}^{\infty} \frac{(\alpha)_{2m}}{(\gamma)_m} \frac{1}{\Gamma(\alpha+2m)} \frac{(x)^m}{m!} \\ \cdot \frac{1}{2\pi i} \int_{-i\infty}^{i\infty} \frac{\Gamma(\alpha+2m+z)}{\Gamma(\delta+z)} \Gamma(\beta+z) \Gamma(-z) (-y)^z dz \quad (62)$$

we obtain

$$H_4(\alpha, \beta; \gamma, \delta; x, y) \\ = - \frac{\Gamma(\beta-\alpha) \Gamma(\delta)}{\Gamma(\beta) \Gamma(\delta-\alpha)} (-y)^{-\alpha} \\ \cdot \sum_{m=0}^{\infty} \sum_{n=0}^{\infty} \frac{(\alpha)_{2m+n} (1+\alpha-\delta)_{2m+n}}{(1+\alpha-\beta)_{2m+n} (\gamma)_m} \frac{(x/y^2)^m}{m!} \frac{(1/y)^n}{n!} \\ - \frac{\Gamma(\alpha-\beta) \Gamma(\delta)}{\Gamma(\alpha) \Gamma(\delta-\beta)} (-y)^{-\beta} \\ \cdot \sum_{m=0}^{\infty} \sum_{n=0}^{\infty} \frac{(\beta)_n (\alpha-\beta)_{2m-n}}{(\gamma)_m} (1+\beta-\delta)_n (-1)^n \frac{(x)^m}{m!} \frac{(1/y)^n}{n!} \quad (63)$$

The next function is

$$H_5(\alpha, \beta; \gamma; x, y) = \sum_{m=0}^{\infty} \sum_{n=0}^{\infty} \frac{(\alpha)_{2m+n} (\beta)_{n-m}}{(\gamma)_n} \frac{x^m}{m!} \frac{y^n}{n!} \quad (64)$$

On considering

$$I = \sum_{m=0}^{\infty} \frac{(\alpha)_{2m}}{(1-\beta)_m} \frac{\Gamma(\gamma)}{\Gamma(\alpha+2m) \Gamma(\beta-m)} (-1)^m \frac{(x)^m}{m!} \\ \cdot \frac{1}{2\pi i} \int_{-i\infty}^{i\infty} \frac{\Gamma(\alpha+2m+z)}{\Gamma(\gamma+z)} \Gamma(\beta-m+z) \Gamma(-z) (-y)^z dz \quad (65)$$

we get

$$H_5(\alpha, \beta; \gamma; x, y) \\ = - \frac{\Gamma(\beta-\alpha) \Gamma(\gamma)}{\Gamma(\beta) \Gamma(\gamma-\alpha)} (-y)^{-\alpha} \\ \cdot \sum_{m=0}^{\infty} \sum_{n=0}^{\infty} \frac{(\alpha)_{2m+n} (1+\alpha-\gamma)_{2m+n}}{(1+\alpha-\beta)_{3m+n}} (-1)^m \frac{(x/y^2)^m}{m!} \frac{(1/y)^n}{n!} \\ - \frac{\Gamma(\alpha-\beta) \Gamma(\gamma)}{\Gamma(\alpha) \Gamma(\gamma-\beta)} (-y)^{-\beta} \\ \cdot \sum_{m=0}^{\infty} \sum_{n=0}^{\infty} \frac{(-1)^n (\alpha-\beta)_{3m-n}}{(1-\beta)_{m-n} (\gamma-\beta)_{m-n}} \frac{(xy)^m}{m!} \frac{(1/y)^n}{n!} \quad (66)$$

The next function is

$$H_6(\alpha, \beta, \gamma; x, y) = \sum_{m=0}^{\infty} \sum_{n=0}^{\infty} (\alpha)_{2m-n} (\beta)_{n-m} (\gamma)_n \frac{x^m}{m!} \frac{y^n}{n!} \quad (67)$$

On considering

$$I = \frac{\Gamma(1-\alpha)}{\Gamma(\beta) \Gamma(\gamma)} \sum_{m=0}^{\infty} \frac{(x)^m}{m!} \\ \cdot \frac{1}{2\pi i} \int_{-i\infty}^{i\infty} \frac{\Gamma(\beta-m+z)}{\Gamma(1-\alpha-2m+z)} \Gamma(\gamma+z) \Gamma(-z) (y)^z dz \quad (68)$$

we obtain

$$H_6(\alpha, \beta, \gamma; x, y)$$

$$= - \frac{\Gamma(1-\alpha) \Gamma(\gamma-\beta)}{\Gamma(1-\alpha-\beta) \Gamma(\beta)} (y)^{-\beta}$$

$$\cdot \sum_{m=0}^{\infty} \sum_{n=0}^{\infty} \frac{(\alpha+\beta)_{m+n} (\gamma-\beta)_{m-n}}{(1-\beta)_{m-n}} (-1)^n \frac{(xy)^m}{m!} \frac{(1/y)^n}{n!}$$

$$- \frac{\Gamma(1-\alpha) \Gamma(\beta-\gamma)}{\Gamma(1-\alpha-\gamma) \Gamma(\beta)} (y)^{-\gamma}$$

$$\cdot \sum_{m=0}^{\infty} \sum_{n=0}^{\infty} \frac{(\alpha+\gamma)_{2m+n} (\gamma)_n}{(1+\gamma-\beta)_{m+n}} (-1)^{m+n} \frac{(x)^m}{m!} \frac{(1/y)^n}{n!}$$

(69)

And finally.

$$H_7(\alpha, \beta, \gamma; \delta; x, y) = \sum_{m=0}^{\infty} \sum_{n=0}^{\infty} \frac{(\alpha)_{2m-n}}{(\delta)_m} (\beta)_n (\gamma)_n \frac{x^m}{m!} \frac{y^n}{n!} \quad (70)$$

On considering

$$I = \frac{\Gamma(1-\alpha)}{\Gamma(\beta)\Gamma(\gamma)} \sum_{m=0}^{\infty} \frac{(\alpha)_{2m}}{(\delta)_m (1-\alpha)_{2m}} \frac{(x)^m}{m!} \\ \cdot \frac{1}{2\pi i} \int_{-i\infty}^{i\infty} \frac{\Gamma(\beta+z)\Gamma(\gamma+z)}{\Gamma(1-\alpha-2m+z)} \Gamma(-z) (y)^z dz \quad (71)$$

we obtain

$$H_7(\alpha, \beta, \gamma; \delta; x, y)$$

$$= - \frac{\Gamma(1-\alpha)\Gamma(\gamma-\beta)}{\Gamma(1-\alpha-\beta)\Gamma(\gamma)} (y)^{-\beta}$$

$$\cdot \sum_{m=0}^{\infty} \sum_{n=0}^{\infty} \frac{(\alpha)_{2m} (\alpha+\beta)_{2m+n} (\beta)_n}{(1-\alpha)_{2m} (\delta)_m (1+\beta-\gamma)_n} (-1)^n \frac{(x)^m}{m!} \frac{(1/y)^n}{n!}$$

$$- \frac{\Gamma(1-\alpha)\Gamma(\beta-\gamma)}{\Gamma(1-\alpha-\gamma)\Gamma(\beta)} (y)^{-\gamma}$$

$$\cdot \sum_{m=0}^{\infty} \sum_{n=0}^{\infty} \frac{(\alpha)_{2m} (\alpha+\gamma)_{2m+n} (\gamma)_n}{(1-\alpha)_{2m} (\delta)_m (1+\gamma-\beta)_n} (-1)^n \frac{(x)^m}{m!} \frac{(1/y)^n}{n!} \quad (72)$$

3. CONCLUSION

We have obtained asymptotic expansions for a class of hypergeometric functions where the magnitude of one of the variables is large while that of the other is small. Using the Barnes-type integral representation the hypergeometric function is analytically continued to the region of interest. The poles that occur are assumed to be simple. The case when the poles are not simple will be considered in another report.

REFERENCES

1. Erdelyi. A., Magnus. W., Oberhettinger. F. and Tricomi. F. G. (1953). Higher Transcendental Functions. Vol. 1. McGraw Hill.
2. Appell. P. and Kampé de Fériet. J. (1926). Fonctions Hypergéométriques et Hypersphériques: Polynômes d'Hermite. Gauthier-Villars.
3. Horn. J. (1931). Hypergeometrische Funktionen zweier Veränderlichen. Math. Ann. 105:381-407.
4. Srivastava. H.M. and Karlsson. P.W. (1985). Multiple Gaussian Hypergeometric Series. Ellis Horwood Ltd.
5. Abramowitz. M. and Stegun. I.M. eds. (1964). Handbook of Mathematical Functions. National Bureau of Standards.

**MISSION
OF
ROME LABORATORY**

Rome Laboratory plans and executes an interdisciplinary program in research, development, test, and technology transition in support of Air Force Command, Control, Communications and Intelligence (C³I) activities for all Air Force platforms. It also executes selected acquisition programs in several areas of expertise. Technical and engineering support within areas of competence is provided to ESD Program Offices (POs) and other ESD elements to perform effective acquisition of C³I systems. In addition, Rome Laboratory's technology supports other AFSC Product Divisions, the Air Force user community, and other DOD and non-DOD agencies. Rome Laboratory maintains technical competence and research programs in areas including, but not limited to, communications, command and control, battle management, intelligence information processing, computational sciences and software producibility, wide area surveillance/sensors, signal processing, solid state sciences, photonics, electromagnetic technology, superconductivity, and electronic reliability/maintainability and testability.