

AD-A279 947

Best Available Copy

AD-A279 947

TECHNOLOGY UTILIZATION REPORT

Office of Technology Utilization

1 NASA

20 Nov 1963

2

~~AN~~ IMPROVED PRECISION HEIGHT GAGE

DTIC
ELECTE
DEC 2 1963
S B D

Source: LESTER B. VALE
Ames Research Center

DISTRIBUTION STATEMENT A
Approved for public release
Distribution Unlimited

NATIONAL AERONAUTICS AND SPACE ADMINISTRATION

WASHINGTON, D. C. • NOVEMBER 1963

NOTICE

This document was prepared under the sponsorship of the National Aeronautics and Space Administration. Neither the United States Government, nor NASA, nor any person acting on behalf of NASA:

A. Makes any warranty or representation, express or implied, with respect to the accuracy, completeness, or usefulness of the information contained in this document, or that the use of any information, apparatus, method, or process disclosed in this document may not infringe privately-owned rights; or

B. Assumes any liabilities with respect to the use of, or for damages resulting from the use of, any information, apparatus, method, or process disclosed in this document.

**For sale by Office of Technical Services, Department of
Commerce, Washington, D. C. 20230--Price \$0.50**

FOREWORD

The Administrator of the National Aeronautics and Space Administration has established a Technology Utilization Program for "the rapid dissemination of information ... on technological developments ... which appear to be useful for general industrial application." From a variety of sources, such as NASA Research Centers and NASA contractors, space-related technology is screened and that which has potential industrial use is made generally available. Thus American industry will receive information from the nation's space program about the latest developments in operating techniques, management systems, materials, processes, products, and analytical and design procedures. This publication is part of a series designed to provide this technical information.

The Director of Technology Utilization
National Aeronautics and Space Administration
Washington, D. C.

DTIC QUALITY INSPECTED 3

3

UNANNOUNCED

ion For	
GRA&I	<input checked="" type="checkbox"/>
AB	<input type="checkbox"/>
Unannounced Justification	<input type="checkbox"/>
By _____	
Distribution/	
Availability Codes	
Dist	Avail and/or Special
A-1	

AN IMPROVED PRECISION HEIGHT GAGE

The precision height gage shown here is a device for making precision measurements of height or differences in height. The gage (figs. 1 and 2) consists of a base upon which are mounted two geometrically similar wedge-shaped blocks in contact along their inclined faces and a micrometer head with its axis parallel to the inclined surfaces, its spindle bearing upon the upper block. The upper block slides upon the lower by action of the micrometer spindle. It is restrained to travel along the axis of the spindle by a tongue and groove between the two blocks. The top surface of the upper block is thus a movable reference plane, its change in

Figure 1. Photograph of improved precision height gage.

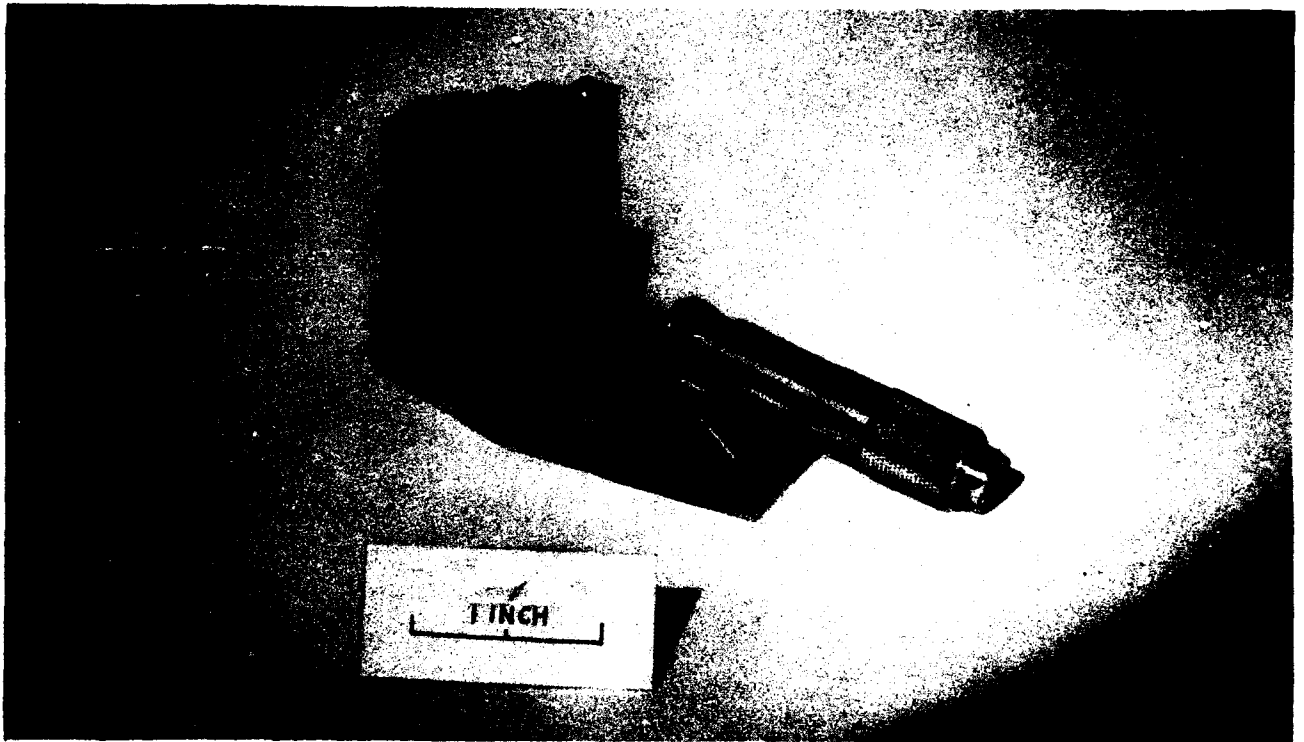

height being measured by the extension or retraction of the micrometer spindle.

The wedge angle of each of the blocks (5.75°) is such that an increase of 1 unit in height of the upper gage-block surface results from an extension of 10 units of the micrometer spindle. The approximate height of the upper block may be read from the indices imprinted on the sides of the blocks; a precise measurement is obtained from the indices and the micrometer reading. The gage is designed so that when both the micrometer and the indices are set at zero, the gage height is a reference height of accurately known magnitude.

Figure 2. Two-view sketch of gage.

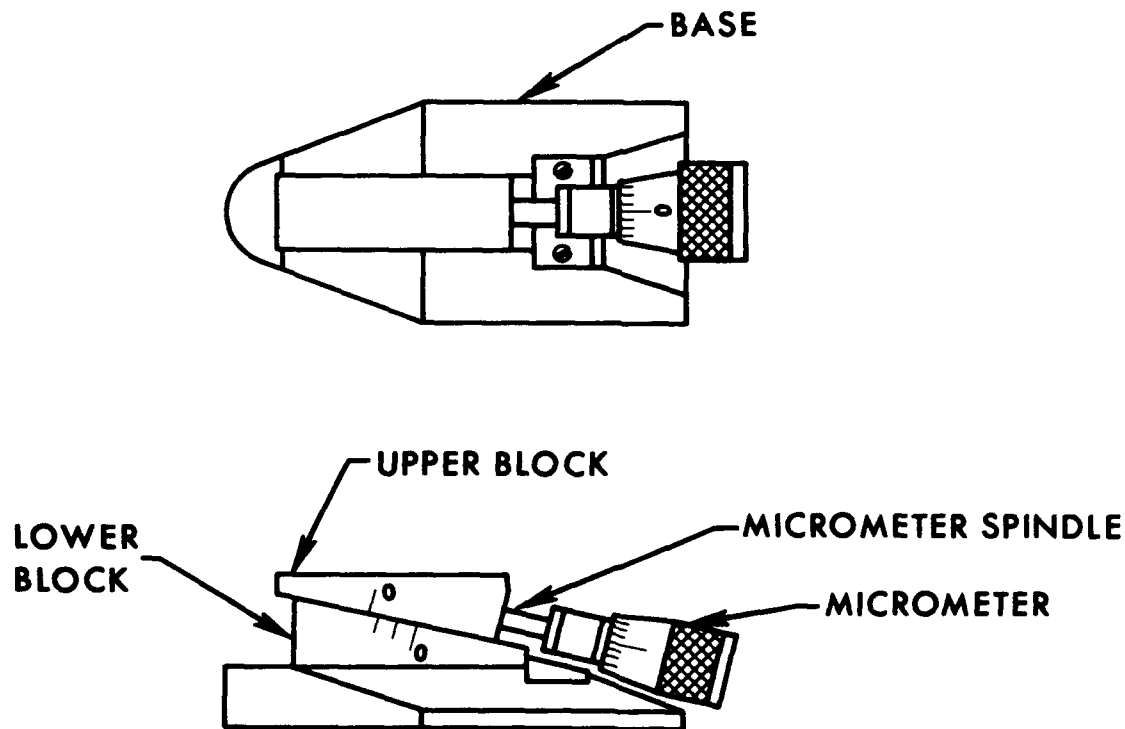

The gage, as now used, is capable of measuring increments of heights up to 1/8 inch in 0.0001-inch increments. The total gage height may be increased as desired by the use of conventional gage blocks.

For purposes of testing and evaluation, a precision height gage of this design was obtained by Southwest Research Institute from NASA's Ames Research Center. According to the Ames Research Center, the gage provided had been in use for approximately 15 years. The gage, when compared against gage blocks and a Pratt and Whitney electrolimit gage, showed a maximum error of 1 part in 20,000 throughout the entire range of the gage.

Other Gages Using Similar Principles

The principle of the sliding wedge in measuring instruments is of course not new. Descriptions of some measuring tools that use this principle and are now available commercially are given below:

1. Planer and shaper gage. This consists of a large wedge-shaped block, the side forming the hypotenuse being dovetailed to receive a smaller similar block. The top of the small block is a reference plane parallel to the base of the large block, and may be set to a desired height above the base by using a micrometer, surface gage, or calipers. The two are then locked together by means of a setscrew and the unit may be used in setting the cutting tool on planers or shapers.

2. Adjustable parallels. This gage is similar to the planer

gage except that the wedge-shaped blocks are smaller and of equal size; it is used to check slot or groove widths.

3. Micrometer plug gage. This is an accurate internal micrometer consisting of several buttons seated around the tapered surface of a cone. The buttons are connected to the spindle of a micrometer and are restrained to motion along the axis of the cone. As the spindle is moved, the set of buttons expands or contracts, this change in dimension being a function of the travel of the micrometer spindle. A less refined version of the micrometer plug gage is called a small-hole gage. In this device a tapered rod sets the distance between two small balls in contact with the sides of the hole to be measured. The rod is locked and the diameter of the hole is obtained by measuring the distance between the outside surfaces of the balls.

4. Taper thickness gage. This device is less closely related to the precision height gage, although it also employs a taper or wedge shape to measure distances. The gage is a strip of hardened steel, very slightly tapered along its length, that may be inserted into a narrow slot. The width of the slot is determined by the depth of insertion and is read from a calibrated scale imprinted on the surface of the gage.

Several patents have been obtained for measuring devices based on the sliding-wedge principle, according to a study by Southwest Research Institute:

Patent No. 875,050, Conlon, 1907: Here a wedge-shaped base is dovetailed on its inclined surface to receive a wedge-shaped

gage block, the upper surface of which is parallel to the bottom of the base block. In addition, an adjusting block designed to slide in the dovetail of the base is provided, the adjusting block carrying a micrometer screw that may be brought into contact with the sliding gage block. The gage block is brought to approximately the desired height by hand, the adjusting block is then moved so that the micrometer screw contacts the gage block, and the adjusting block is locked to the base. The gage block is then adjusted to the desired height by means of the micrometer screw and is locked to the base. Since there is no means for accurately setting the absolute height of the gage block, this device is chiefly useful for comparing heights or measuring small differences in height.

Patent No. 1,040,774, Schamel, 1912: This device also includes a wedge base and sliding gage block. The gage block is moved along the inclined surface of the base by a micrometer screw parallel to the inclined surface. The micrometer screw is threaded through the gage block, and is sufficiently long to cause the gage block to be moved along the whole length of the inclined plane.

Patent No. 1,351,528, Martin, 1920: This gage is very similar to Schamel's, except that the screw for positioning the gage block is not a micrometer-type screw and cannot be used to measure gage-block position. The gage must be set for the proper height by an auxiliary measuring device. Provisions are made for inside and outside caliper blades to be attached to the base and gage block.

Patent No. 1,472,837, Hoke, 1923: This device consists of two gage blocks with one side of each block slightly tapered. The tapers on each block are cut at equal angles so that when the tapered sides are placed together, the opposite sides of the two blocks are parallel. The thickness of the two blocks together may be adjusted through a small range by adjusting the relative position of the two blocks. The change in thickness is read from the indices stamped on the sides of each block.

Patent No. 2,353,886, Findley, et al., 1944: The operating principle of this gage is very similar to that of Martin's gage, the differences being in detail design only.

Ways It Can Be Used

The precision height gage has been in continuous use in the machine shop of the Ames Research Center for some years. Because of its accuracy and ease of operation, it has replaced gage blocks in many shop operations. The Ames machine shop constructed several of these gages and reports that they have served over the years with significant savings of man-hours and gage-block replacement costs.

Some of the possible uses of precision height gages are as follows:

1. Checking accuracy of tools, dies, and fixtures.
2. Increasing the accuracy of machine setups.
3. Checking parts in process of manufacture and finished parts.

4. Setting adjustable instruments and indicating gages. In this category, an excellent application would seem to be the use of the device in setting sine bars and sine tables.

5. Verifying inspection gages.

Estimated Costs and Savings

In order to estimate the cost of producing quantities of the precision height gage shown in figures 1 and 2, each component of the gage was compared with similar existing equipment (gage blocks, taper parallels, micrometers, etc.); allowances were made for differences, and overall price was estimated. From this analysis, it is estimated by the Southwest Research Institute that the retail price of the precision height gage would be between \$30 and \$40, depending on the precision of manufacture.

The savings realized by the user will result primarily from two sources: First, the more rapid completion of a given measuring or inspection task, and second, the lower usage and consequent savings on replacement of more expensive measuring tools.

It should be pointed out that conventional gage blocks have a wide variety of applications when used with various available attachments; the use of the precision height gage, on the other hand, is somewhat limited by its size and configuration. The savings from lower usage of gage blocks may therefore be relatively minor. If this factor is neglected and it is assumed that the height gage is used twice a day with a saving of 3 minutes per use, it can be estimated that the cost of the gage might be recovered in 4 months.

Variations and Attachments Could Be Developed

Two of many possible variations of the precision height gage, using the sliding-wedge principle, are shown in figure 3. The first is an adjustable snap gage in which the distance between the gage buttons may be adjusted within limits by the movement of the micrometer spindle acting upon two sliding wedges.

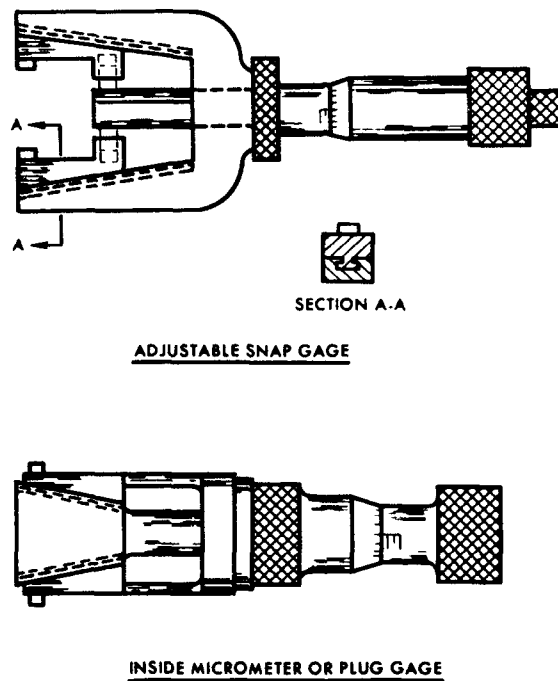

Figure 3. Possible variations of sliding-wedge principle.

The second variation shown is similar to the adjustable plug gage discussed previously. Two wedges are expanded by the motion of the micrometer as they slide along a hardened pyramidal wedge. This gage could be used as an inside micrometer or plug gage.

The utility of the basic height gage shown in figures 1 and 2 could be greatly increased by the provision of several attachments. Among these are:

1. Inside and outside caliper jaws to be fitted on the front face of the wedge blocks to provide a means for accurate measurement of parts suitable for measurement with calipers.

2. Scriber and center-point attachments to be fitted on the upper wedge block so that work piece layout may be facilitated.

Conclusions

The precision height gage is a useful innovation in the field of precision measurement and would be expected to have considerable practical application. Although the principle used in the gage is not radically new, the design and construction of the gage results in performance and accuracy superior to those of previous similar devices. It may be accurately set to a desired height without auxiliary measuring devices, there is no lost motion in the movement of the upper block, and the resolution of the instrument is improved by fully utilizing the mechanical advantage inherent in the sliding-wedge principle. Taken together, these characteristics provide considerable improvement over the devices discussed earlier in this report.