

UNCLASSIFIED

AD NUMBER

ADA279796

CLASSIFICATION CHANGES

TO: unclassified

FROM: restricted

LIMITATION CHANGES

TO:
Approved for public release, distribution
unlimited

FROM:
Controlling Organization: US National
Aeronautical and Spaca Administration,
Washington, DC.

AUTHORITY

E.O. 10501, 5 Nov 1953; NASA, 5 Nov 1953

THIS PAGE IS UNCLASSIFIED

AD-A279 796



94-14779



7888

RESTRICTED
UNCLASSIFIED

NACA CONFERENCE
ON SOME PROBLEMS OF AIRCRAFT OPERATION

A COMPILATION OF THE PAPERS PRESENTED

Lewis Flight Propulsion Laboratory
Cleveland, Ohio

October 9 and 10, 1950

DTIC QUALITY INSPECTED 3

RESTRICTED
UNCLASSIFIED

UNCLASSIFIED
RESTRICTED

CONTENTS

	Page
INTRODUCTION	vii
LIST OF CONFEREES	ix
TECHNICAL DISCUSSIONS:	
ATMOSPHERIC TURBULENCE AND ITS EFFECT ON AIRCRAFT OPERATION	
1. ELEMENTS OF THE FATIGUE PROBLEM. By PAUL KUHN	1
2. INTRODUCTION TO THE PROBLEM OF REPEATED GUST LOADS. By H. B. TOLEFSON	7
3. GUST-LOAD EXPERIENCE IN TRANSPORT OPERATIONS. By JOHN R. WESTFALL and ROY STEINER	15
4. THE DETECTION AND FORECASTING OF TURBULENCE. By JAMES K. THOMPSON	21
5. SOME ASPECTS OF GUST ALLEVIATION. By HAROLD B. PIERCE	28
6. ANALYSIS OF MEANS TO INCREASE THE SMOOTHNESS OF FLIGHT THROUGH ROUGH AIR. By WILLIAM H. PHILLIPS	34
SOME ASPECTS OF AIRCRAFT SAFETY - ICING, DITCHING AND FIRE	
7. METEOROLOGICAL FACTORS IN THE DESIGN AND OPERATION OF THERMAL ICE PROTECTION EQUIPMENT FOR HIGH-SPEED, HIGH-ALTITUDE TRANSPORT AIRPLANES. By WILLIAM LEWIS, U. S. Weather Bureau	39
8. THERMAL ICE PROTECTION FOR HIGH-SPEED TRANSPORT AIRPLANES By THOMAS F. GELDER and STANLEY V. KOUTZ	50
9. AIRCRAFT OPERATIONAL PROBLEMS INVOLVED IN DITCHING. By LLOYD J. FISHER	58
10. SOME ASPECTS OF THE TRANSPORT AIRPLANE FIRE PROBLEM. By I. IRVING PINKEL	64

UNCLASSIFIED
RESTRICTED

AERODYNAMIC CONSIDERATIONS FOR HIGH-SPEED TRANSPORT AIRPLANES

- 11. REVIEW OF AIRPLANE CHARACTERISTICS PERTAINING TO HIGH-SPEED PERFORMANCE.
By RALPH P. BIELAT 73
- 12. PROBLEMS OF OBTAINING SATISFACTORY LOW-SPEED FLYING QUALITIES FOR THIN-WING AND SWEEP-WING AIRPLANES.
By LAWRENCE A. CLOUSING 81
- 13. SPEED BRAKES FOR HIGH-SPEED TRANSPORT AIRPLANES.
By JACK D. STEPHENSON 92
- 14. REVIEW OF HANDLING QUALITIES REQUIREMENTS IN RELATION TO AIRPLANE OPERATING PROBLEMS.
By CHRISTOPHER C. KRAFT, Jr. 99
- 15. A STUDY OF REQUIREMENTS FOR POWER-OPERATED CONTROLS AND MECHANICAL-FEEL DEVICES.
By B. PORTER BROWN 105

PROPULSION CONSIDERATIONS FOR HIGH-SPEED TRANSPORT AIRPLANES

- 16. SOME CONSIDERATIONS OF AIRCRAFT NOISE.
By HARVEY H. HUBBARD 112
- 17. PROPELLER CONSIDERATIONS FOR HIGH-SPEED TRANSPORT AIRPLANES.
By BLAKE W. CORSON, Jr., and JOHN L. CRIGLER 119
- 18. POWER PLANTS FOR HIGH-SPEED TRANSPORT AIRPLANES.
By BRUCE T. LUNDIN and ELDON W. HALL 127
- 19. OPERATIONAL CHARACTERISTICS OF TURBINE ENGINES.
By WILLIAN A. FLEMING and REECE V. HENSLEY 137

v

Accession For	
NTIS GRA&I	<input type="checkbox"/>
DTIC TAB	<input checked="" type="checkbox"/>
Unannounced	<input type="checkbox"/>
Justification	
By	
Distribution/	
Availability Codes	
Dist	Avail and/or Special
12	

RESTRICTED

INTRODUCTION

This volume contains copies of the technical papers presented at the NACA Conference on Some Problems of Aircraft Operation on October 9 and 10, 1950 at the Lewis Flight Propulsion Laboratory. This conference was attended by members of the aircraft industry and military services.

The original presentation and this record are considered as complimentary to, rather than as substitutes for, the Committee's system of complete and formal reports.

A list of the conferees is included.

NATIONAL ADVISORY COMMITTEE
FOR AERONAUTICS

RESTRICTED

RESTRICTED

LIST OF CONFEREES

The following conferees were registered at the NACA conference on Some Problems of Aircraft Operation, Lewis Flight Propulsion Laboratory, Cleveland, Ohio, October 9 and 10, 1950:

Addams, W. J.	United Airlines
Allen, J. J.	AMC, U. S. Air Force
Andrew, G. M.	Ryan Aeronautical
Andrus, C. G.	U. S. Weather Bureau
Argabright, E. V.	AMC, U. S. Air Force
Bassett, P. R. (1)	Sperry Gyroscope
Bates, R. E.	Douglas Aircraft
Bielat, R. P.	NACA - Langley
Blem, Trygve	AMC, U. S. Air Force
Borger, J. G.	Pan American World Airways
Boudwin, J. A.	Civil Aeronautics Administration
Bowman, R. J.	Republic Aviation
Brown, B. P.	NACA - Langley
Brown, Cdr. I. W.	NATC - Patuxent, USN
Burghardt, J. E.	Glenn L. Martin
Byers, H. R. (5)	University of Chicago
Cahill, M. B.	Northwest Airlines
Caldwell, L. H.	Capital Airlines
Callander, A. D.	Glenn L. Martin
Cantwell, R. A.	AMC, U. S. Air Force
Carlson, R. M.	AMC, U. S. Air Force
Cesaro, R.	NACA - Washington
Chasman, B. (6)	AMC, U. S. Air Force
Chenoweth, O.	AMC, U. S. Air Force
Cleusing, L. A.	NACA - Ames
Collins, J. H.	NACA - Lewis
Collins, W.	Continental Aviation
Conlon, E. W. (4)	University of Michigan
Corson, B. W.	NACA - Langley
Crane, K. D.	National Airlines
Crigler, J. L.	NACA - Langley
Crowley, J. W.	NACA - Washington

- (1) Member NACA Committee on Operating Problems
 (4) Member NACA Committee on Aircraft Construction
 (5) Member NACA Subcommittee on Meteorological Problems
 (6) Member NACA Subcommittee on Icing Problems

RESTRICTED

Croxall, A. D.	Hamilton Standard
Crozat, D. F.	Curtiss-Wright (Prop.Div.)
Cudhea, D. E.	Chase Aircraft
Dahl, Lt. Cdr. M. P.	EMTC - Patuxent, USN.
Dallas, A. W. (7)	Air Transport Association
Davis, Capt. F. E.	Eastern Airlines
Dernbach, A. F.	AMC, U. S. Air Force
Dickey, D. A.	AMC, U. S. Air Force
Dickinson, W. T. (1) (7)	Douglas Aircraft
Diehl, Capt. W. S. (2)	Bureau of Aeronautics
Donely, Philip (5)	NACA - Langley
Dunn, T. M.	Pan-American Grace Airways
Dyment, John T.	Trans-Canada Airlines
Evvard, Dr. J. C.	NACA - Lewis
Farron, M. B.	Trans-World Airlines
Farkas, A. S.	Bureau of Aeronautics
Faustman, Capt. D. H.	AMC Engineering Field Officer, NACA
Fisher, L. J.	NACA - Langley
Fisher, Lt. Cdr. P. S.	EMTC - Patuxent, USN.
Fleming, W. A.	NACA - Lewis
Fletcher, T. F.	Hughes Aircraft
Freeburg, M. B.	Northwest Airlines
Freesch, C. (1)	Eastern Airlines
Furnas, C. C. (4)	Cornell University
Geary, R. H.	Air Transport Service
Gelstad, D. A.	Bureau of Aeronautics
Gilley, S. T.	Piedmont Airlines
Goldsmith, J.	Pratt & Whitney
Goranson, F.	NACA - Washington
Gough, M. A.	NACA - Langley
Grimes, E. K.	AMC, U. S. Air Force
Gunn, Ross (5)	U. S. Weather Bureau
Haile, Lt. Col. J. E.	NACA Liaison Officer - Ames
Hall, Eldon W.	NACA - Lewis
Hall, J. H.	NACA - Lewis

- (1) Member NACA Committee on Operating Problems
- (2) Member NACA Committee on Aerodynamics
- (4) Member NACA Committee on Aircraft Construction
- (5) Member NACA Subcommittee on Meteorological Problems
- (7) Member NACA Subcommittee on Fire Prevention

RESTRICTED

Hammen, T. F.	Fairchild Engine & Airplane
Hartman, E. P.	NACA Western Coordination Officer
Hasert, C. N.	Research and Development Board, USAF
Haugen, K. B.	Northwest Airlines
Heckert, J. S.	Civil Aeronautics Board
Helms, C. H.	NACA - Washington
Hensley, R. V.	NACA - Lewis
Herrington, F. W.	Naval Aviator - Moffett Field
Hertzberg, T. H.	AMC, U. S. Air Force
Hoben, H. E. (7)	American Airlines
Hoover, H. H.	NACA - Langley
Hubbard, H. H.	NACA - Langley
Hunter, W. H.	NACA - Lewis
Jacobson, B. H.	Aeroproducts Div., GMC
Jones, J. C.	AMC, U. S. Air Force
Kasley, J. H.	Curtiss-Wright (Prop.Div.)
Katzoff, S.	NACA - Langley
Kayten, G. G.	Bureau of Aeronautics
Kelly, R. D. (7)	United Airlines
Kemper, C.	NACA - Lewis
Kershaw, E. J.	National Airlines
Kirchner, O. E. (2)	American Airlines
Klein, D. B.	U. S. Weather Bureau
Klein, H.	Douglas Aircraft
Koegler, R.	Cornell Aero. Lab.
Kreepnick, L. R.	AMC, U. S. Air Force
Kraft, C. C.	NACA - Langley
Larned, W. E.	United Airlines
Lawrence, W. C. (3)	American Airlines
LeClaire, J. G.	Trans-World Airlines
Lederer, Jerome (1)	Flight Safety Foundation
Lewis, W.	U. S. Weather Bureau
Louden, F. A. (2)	Bureau of Aeronautics
Lundin, B. T.	NACA - Lewis
Lynn, Lt. Cdr. J.	Patuxent
McBrien, R. L.	United Airlines

- (1) Member NACA Committee on Operating Problems
- (2) Member NACA Committee on Aerodynamics
- (3) Member NACA Committee on Power Plants
- (7) Member Subcommittee on Fire Prevention

Maccubbin, Cdr. A. L. (1)	Bureau of Aeronautics
Maggin, B.	NACA - Washington
Manganiello, E. J.	NACA - Lewis
McIntosh, C. H.	All American Airways
Mentzer, W. C. (1) (4)	United Airlines
Monroe, D. E.	NAMC - Patuxent, USN
Myers, B. C.	NACA - Washington
Myers, Dr. F. G.	Glenn L. Martin
North, D. A. (6)	American Airlines
Olson, Dr. W. T.	NACA - Lewis
O'Toole, J. M.	General Electric
Parkinson, J. B.	NACA - Langley
Payne, Maj. G. L.	NAMC - Patuxent, USN
Peerson, H. A.	NACA - Langley
Pederson, J. M.	General Electric
Pennell, M. L.	Boeing Airplane
Perkins, D. T.	Andrews Air Force Base
Phillips, F. W.	NACA - Washington
Phillips, W. H.	NACA - Langley
Pierce, H. B.	NACA - Langley
Pinkel, B.	NACA - Lewis
Pinkel, I. I. (5)	NACA - Lewis
Prentiss, Maj. V.	AMC, U. S. Air Force
Rhoades, W. E.	United Airlines
Rhode, R. V.	NACA - Washington
Riley, W.	Capital Airlines
Rinker, J. T.	Civil Aeronautics Board
Robins, Maj. N. B.	AMC, U. S. Air Force
Rochte, Lt. Col. L. S.	AMC, U. S. Air Force
Rodert, L. A.	NACA - Lewis
Rodewald, Maj. D. L.	Mitchell Air Force Base
Rolle, S. (3) (6)	Civil Aeronautics Administration
Rosenfield, Maj. W. A.	AMC, U. S. Air Force
Ruie, R. L.	Boeing Airplane
Rummell, R. W.	Trans-World Airlines

- (1) Member NACA Committee on Operating Problems
- (3) Member NACA Committee on Power Plants
- (4) Member NACA Committee on Aircraft Construction
- (5) Member NACA Subcommittee on Meteorological Problems
- (6) Member NACA Subcommittee on Icing Problems

Sanders, N. D.	NACA - Lewis
Sawyer, R. E.	Braniff Airways
Schey, O. W.	NACA - Lewis
Schoech, H. H.	NATC - Patuxent, USN
Schumacher, L. E.	AMC, U. S. Air Force
Sharp, Dr. E. R.	NACA - Lewis
Silverstein, A.	NACA - Lewis
Smithline, L.	Chase Aircraft
Smull, T. K. L.	NACA - Washington
Snyder, G.	Boeing Airplane
Spaulding, E. H.	Lockheed Aircraft
Steading, J.	Allison Div., GMC
Steiner, J. E.	Boeing Airplane
Stephenson, J. D.	NACA - Ames
Stroukoff, M.	Chase Aircraft
Stuber, B. V.	NATC - Patuxent, USN
Stullman, F. B.	Curtiss-Wright (Prop. Div.)
Sulick, Lt. T. E.	NATC - Patuxent, USN
Talmage, D.	NACA - Washington
Templin, R. L.	Aluminum Company of America
Thieblot, A. J.	Fairchild Engine & Airplane
Thompson, J. K.	NACA - Langley
Thoren, T. R.	Thompson Products
Tolefson, H.	NACA - Langley
Trimbach, C. G. (7)	Cornell Aero. Lab.
Tsu, C. N.	Northrop Aircraft
Tusch, C. W.	NACA Liaison Office - Ames
Tyden, W.	Fairchild Engine & Airplane
Underwood, W. J.	NACA Liaison Officer-AMC, Dayton
Vollmecke, A. A. (4)	Civil Aeronautics Administration
Wasielowski, E. W.	NACA - Lewis
Weiler, H. E.	Westinghouse
Westfall, J. R.	NACA - Langley
Whitten, J. B.	NACA - Langley
Woodard, Lt. Col. W. W.	AMC, U. S. Air Force
Yates, Lt. Col. W. J.	USAF - Norton Air Force Base
Zahringer, J. T.	NATC - Patuxent, USN

(4) Member NACA Committee on Aircraft Construction

(7) Member NACA Subcommittee on Fire Prevention

RESTRICTED

ATMOSPHERIC TURBULENCE AND ITS EFFECT ON AIRCRAFT OPERATION

RESTRICTED

1. ELEMENTS OF THE FATIGUE PROBLEM

By Paul Kuhn

RESTRICTED

ATMOSPHERIC TURBULENCE AND ITS EFFECT
ON AIRCRAFT OPERATION

I - ELEMENTS OF THE FATIGUE PROBLEM

By Paul Kuhn

Langley Aeronautical Laboratory

Some of the problems associated with atmospheric turbulence and its effects on airplane operation can be appreciated readily without any background of special knowledge. Even a layman without any knowledge of flying can appreciate the effect of turbulence on passenger comfort. With a little imagination, he can understand that very violent turbulence may break the airplane. The most insidious effect of turbulence, however, and potentially at least the most important, can be appreciated only with some background of specialized knowledge. It is the promotion of fatigue failure.

Fatigue failures are an old story to transportation engineers. In 1850, there was a meeting of mechanical engineers in England at which a paper was presented dealing with fatigue failures of railway axles. The speaker stated, among other things, that he was collecting statistics on service failures. A few years later, a German railway engineer started systematic fatigue tests on railway axles. The curves he plotted are known to engineers in Europe by his name, in our country, more prosaically, as fatigue curves or S-N curves. Around 1950, there were several engineering meetings in England, in Australia, and in the United States, devoted specifically to discussions of fatigue, and railway axles received their share of attention in all of them.

Now, it is not impossible to build machinery that will live, perhaps not forever, but certainly to an astonishing age. One-lunger boat engines half a century old are not uncommon, and steam engines even older are still going strong without fatigue failure. However, if the age of such engines is astonishing, their weight is even more astonishing. Airplane engines and airplane frames built on similar principles would most certainly be safe against fatigue failure in the air, because they would never leave the ground. If man insists on his machinery leaving the ground, he must accept some risk of static or fatigue failure.

RESTRICTED

Static failures in the air were common in the earliest days of aviation. This situation was greatly improved by the use of more careful stress analysis, accompanied by strength tests and by the use of high load factors. With relatively high load factors, low airplane speeds and small numbers of flight hours, fatigue failures were rather rare and generally attributable to vibration induced by the engine or aerodynamically. However, over twenty years ago, a series of fatigue failures occurred in the spar caps of a European transport type that were probably caused by gust loads. Since then, there has been a steady trend to whittle down the load factors, to increase the speed, and to increase the total number of flight hours of transport type airplanes. With this trend, it is becoming more and more difficult to postpone fatigue failures long enough to obtain the desired service life of the structure.

What can be done to ensure a structure that is at least reasonably satisfactory is now to be considered. A glance at the history of airplane engine design may be instructive. For a long time, engines were notorious for developing fatigue troubles. Intensive efforts were made to decrease these troubles by improving design methods and features, materials, and materials processing, and by keeping close tab on service experience. With all this vast backlog of experience for the improvement of engine design, each new type still goes through a lengthy debugging period, and an acceptance run is still required for any new type of engine.

Consideration has been given to fatigue tests on airplanes comparable to the acceptance runs of engines. Assume that the airplane is to have a life of 50,000 flying hours. The fatigue test would have to duplicate the fraction of that time that is spent in turbulent air. A widely used number for that fraction is one-tenth. The fatigue test would thus require 5,000 hours, or about 7 months. That would be 24 hours a day running time, with no time allowance for stops to inspect for cracks, or perhaps to repair the parts of the loading apparatus that have failed in fatigue. The time estimate assumes furthermore that the test speed can be adjusted to obtain values corresponding to flight conditions. This may be extremely difficult in some airplanes without running the risk of having the test become misleading. It appears, then, that the road to a good test technique will be a long and expensive one.

In any event, a procedure for testing a completed airplane is obviously not a good substitute for a design procedure when dealing with such a large and expensive structure as an airplane. The desired goal is to predict the fatigue life by calculation. Such a

prediction, just like a prediction of static strength, requires that three questions be answered:

- (1) What are the repeated loads?
- (2) What stresses are caused by these loads?
- (3) What are the allowable stresses?

The first question, that of repeated loads, is dealt with in subsequent papers. Attention should be called to the fact that the loads can be defined only on a statistical basis. This means that it is impossible to predict the life of one given airplane. It is only possible to predict something like the average life of a large fleet of airplanes, a hundred, for example. Some airplanes will live longer than the average, some not so long. The operation of any given airplane therefore necessarily involves some risk. For design purposes, it is necessary to put a number on this risk, in order to make it a calculated risk. How to arrive at this number is one of the many open questions. For passenger airplanes, perhaps as good a suggestion as any is to make this risk equal to the risk of everyday life on the ground as measured by the premium rates of life insurance companies.

On the second question, that of stresses caused by loads, it should be noted that a reasonably reliable prediction of fatigue life would require a much more complete and accurate stress analysis than is currently customary. Much can be done by more complete use of available knowledge. A considerable portion of the NACA research on structures has always been devoted to stress analysis. However, much additional research is needed on such items as stresses around cut-outs, sudden changes of cross section, and the large complex of problems usually lumped in the term "secondary stresses." This term was coined in the days when only static strength was of concern. When fatigue comes into the picture, the so-called secondary stresses often assume primary importance.

The third question, that of the allowable stresses, is rather easily answered for static strength design, but not so for fatigue design. A number of factors that are unimportant or non-existent in the static case become very important in the repeated load case. The main factors are scatter in test results, complexity of load history, and stress-concentration effects.

The first factor is illustrated in figure 1. The figure shows results obtained in rotating-beam fatigue tests. The maximum stress, S , experienced by one fiber of the beam during one revolution is

plotted against N , the number of cycles to failure. At each stress level, a number of specimens were tested. The average life for the group is denoted by a circle. The circles fall fairly close to a smooth curve, and in this particular case, this curve agrees very closely with the corresponding one established by the Aluminum Company of America. However, the life of the longest-lived specimen at a given stress level, denoted by a tickmark, differs from that of the shortest lived one by a factor of about ten. In other tests, this scatter may be worse, and the average curves obtained in different laboratories often differ by quite a margin.

This scatter has often been attributed to variation of material properties, but no correlation with any material property has been established to date. It is known qualitatively that the machining procedure used to make the specimens is quite important. There is also a school of thought which holds that at least part of the scatter is associated with the fact that the atoms of the material move about in a random fashion, which is of course beyond control.

Figure 2 conveys some idea of the problem of complexity of load pattern. The top of the figure shows an actual load record from an airplane flying through turbulent air. The acceleration at the airplane C.G. is plotted against time. Obviously, the pattern is very complex. The lower part of the slide shows load patterns obtainable in fatigue machines. Pattern One is a stress oscillating with constant amplitude about a mean value of zero. The rotating-beam machine has such a pattern. Pattern Two shows a constant mean stress and, superposed on it, an oscillating stress of constant amplitude. This is the pattern used at present to obtain design allowable stresses. In Pattern Three, a certain number of cycles is applied with one stress amplitude; then the amplitude is changed, and the loading is continued until failure occurs. Now, if the larger amplitude were applied first in this test, and then the smaller amplitude, the result would be quite different. The allowable stress depends not only on the number and magnitude of the stresses, but also on the sequence of application.

Pattern Four has a number of amplitudes, arranged in a block or sequence. The entire block is repeated until failure occurs. If the number of cycles at each amplitude is made to agree with the statistical distribution of gust loads, the test is known as a gust-spectrum test. It is the closest approximation to the actual load pattern in the airplane that is now considered practicable. At present, there is no fatigue machine in this country capable of performing such tests efficiently. However, a medium-capacity machine

of this type is undergoing calibration at the NACA Langley Aeronautical Laboratory and a larger one is under contract. An important phase of the research work will be to see how well test results obtained under Pattern Four can be predicted from the design allowables obtained under Pattern Two. Later, the electronic control on the first machine will be changed; the new control will use a one-hundred hour gust load record as basic control medium to apply the actual complex load pattern to the test specimens.

In the past three years, a large amount of work has been done under a large-scale program to establish design allowable stresses for airframe materials. This work is carried out in part by the Battelle Memorial Institute, in part by the NACA Langley Aeronautical Laboratory. It includes determination of allowable stresses on the most important airframe materials, the effects of stress raisers, the effect of size of stress raisers, and the effects of yielding. A large amount of work remains to be done, however, to establish these effects quantitatively. One of the great difficulties in this work is the inherently large scatter in all fatigue tests which makes it necessary to test large numbers of specimens.

A number of other fatigue problems are being investigated under contract at several universities.

The problem of detecting fatigue failures as early as possible is one of great interest to research men as well as to operators. The failure starts as a very small crack, which grows slowly or rapidly until the part breaks statically. In simple specimens, at least, the crack does not form in the majority of cases until 50 to 90 percent of the fatigue life has been exhausted, that is, the major part of the fatigue damage is done before there is any crack. Although much effort has been devoted to the problem of detecting fatigue damage, there exists at present no method for detecting damage short of an actual crack. Once a crack has formed, it is possible to see the damage, provided that the crack is located some place where it can be seen. There are various methods for facilitating the detection of cracks. On an airplane structure, many parts are unfortunately not accessible to visual inspection. There are methods for detecting internal cracks, but there seems to be little hope that these methods can ever be applied to anything but extremely simple individual pieces.

Fatigue tests being made on transport airplanes are another example of NACA research in the fatigue field. Twenty C-46 airplanes were obtained from war surplus. The central portion of the fuselage

is mounted between two supports. The outer portions of the wings are removed. A concentrated mass is attached to the new tip of each wing to produce in the root region stresses of the same magnitude as the 1 g stresses in level flight. Pushrods fastened to the wing tips produce an oscillating load of 0.625 g at the natural frequency of the wing, 101 cycles per minute. The distribution of the flight stresses is approximated fairly closely over a spanwise distance of about one-third of the original span. From these tests an effort will be made to determine whether the scatter in tests on complex structures is greater, less, or the same as in tests on simple specimens.

It may seem that the fatigue problem is a somewhat hopeless one. Unquestionably, a very large amount of work remains to be done and it must be admitted that the picture does look confused at present in some respects. However, there is good reason to believe that the situation will improve considerably within a few years. Methods of accounting for some of the disturbing factors, such as size effect, have been proposed that seem to offer good promise, and the elimination of any one disturbing factor greatly helps to speed up the task of cleaning up the remaining ones.

In conclusion, a parallel may be drawn. The fatigue life of a structure is analogous to the life of a human being in that it is finite, and that it cannot be predicted for any one individual with great certainty or accuracy. Advances in medical research do not constitute a guarantee that the life of one given individual will be increased, but they do guarantee that the average life span will be increased, other things being equal. The same applies to fatigue research.

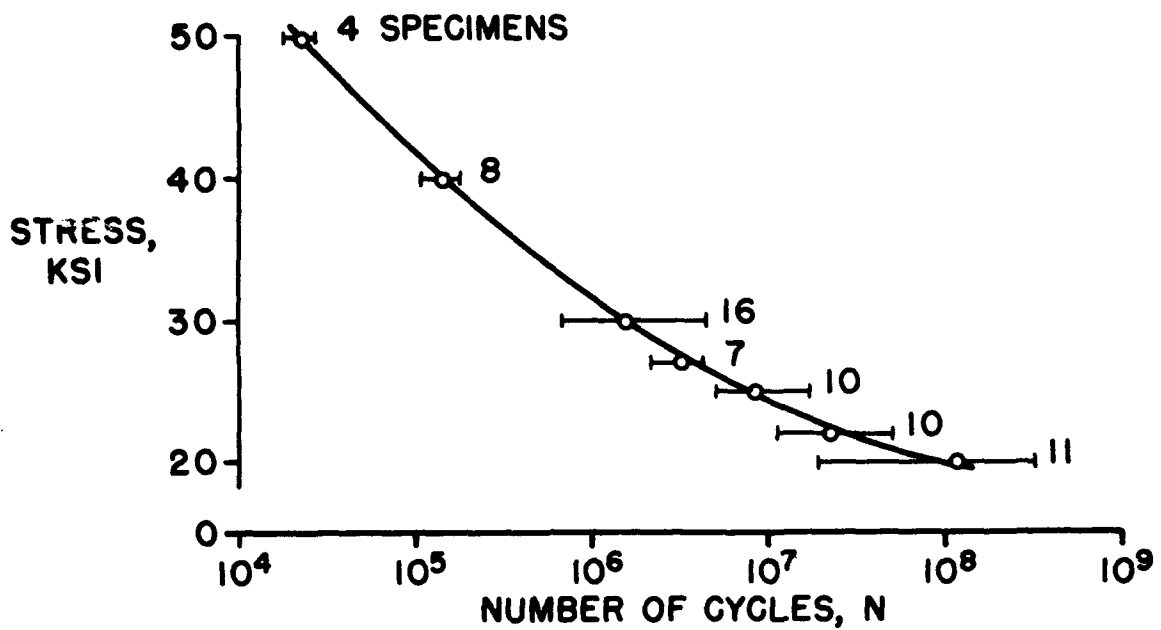

Figure 1. - Rotating-beam fatigue tests; 24S-T alloy.

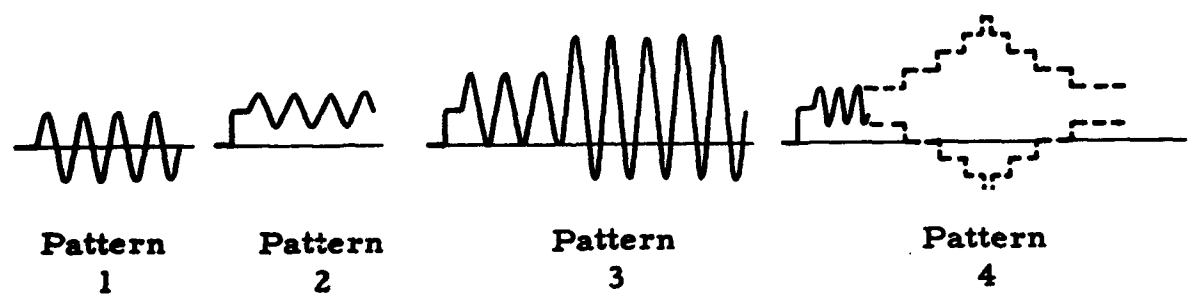
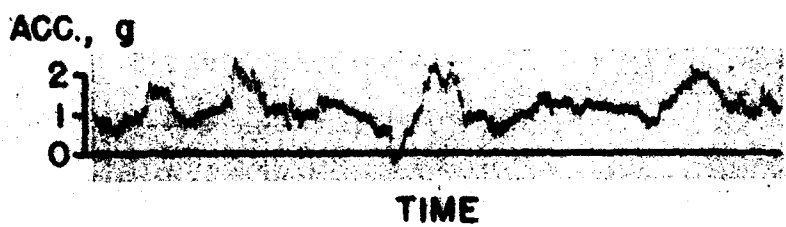

Figure 2. - Typical load patterns on airplane and on fatigue machines.

2. INTRODUCTION TO THE PROBLEM OF REPEATED GUST LOADS

By H. B. Tolefson

ATMOSPHERIC TURBULENCE AND ITS EFFECT

ON AIRCRAFT OPERATION

2. INTRODUCTION TO THE PROBLEM OF

REPEATED GUST LOADS

By H. B. Tolefson

Langley Aeronautical Laboratory

The problem of repeated gust loads is to define the gust load experience of an airplane during its life. The problem is general in that it covers all the many gust load experiences of the airplane without specific regard to the occurrence of single large loads or to the sequence in which the loads are applied. The solution to this problem is required so that the effects of gusts upon airplanes can be designed for, reduced, or avoided. The purpose of this paper is to present the elements of the recurrent-gust-load problem and to provide some background for subsequent papers on gust loads.

The problem of repeated gust loads resolves into three parts: The determination of the pertinent gust characteristics and the frequency of occurrence of gusts in the atmosphere, the influence of airplane characteristics on the loads imposed by the gust, and finally, the determination of the operating conditions, or the manner in which the airplane is flown and dispatched with regard to rough air.

Before taking up the three parts of the problem, a review will be made of the concepts of gusts and of available methods and instruments for measuring gusts. It is obvious that gusts in the atmosphere have a wide variety of dimensions, or sizes, and that the velocities may have any vertical or lateral direction. From the standpoint of wing loads, however, past work has indicated that the vertical velocities are most important. The work has also indicated that significant gusts are those roughly the size of the airplane, although quite wide variations exist. The two basic elements of a gust used in this work are therefore considered its vertical component of velocity and its size. These elements are illustrated in the first figure, which shows the velocity profile of an average gust. As indicated, the velocity is directed upwards and the profile

is assumed to be symmetrical. The exact shape of the profile is not too important for most work, and in some cases a sine wave is assumed while in others a peaked gust is used. The distance H in which velocity increases to a maximum is used as a measure of the size of the gust and is called the gradient distance. The vertical velocity at any point within the gust is assumed to be uniform across the airplane span.

In reducing the calculation of gust loads to its simplest form, consider the condition in which the airplane is traveling at velocity V and suddenly encounters the vertical gust velocity U . The gust equation in figure 1 for this condition indicates that the maximum acceleration increment experienced by the airplane is a function of air density, slope of lift curve, vertical component of gust velocity, forward speed, and wing loading (reference 1). The factor K accounts for the vertical movement of the airplane in the gust and for the fact that full lift is not realized immediately for a sudden change in angle of attack.

In routine evaluation of large amounts of data with the equation, it has been found convenient to base the value of K on a gust with an average gradient distance and to use sea level air density and equivalent airspeed. The gust velocity obtained with these substitutions in the equation is called the effective gust velocity (reference 1). This is a fictitious value, but since it is a measure of the load producing capabilities of the gust and is quite easily obtained, the effective gust velocity is widely used in loads work.

The best estimate of the true maximum gust velocity is obtained if true airspeed and density are used in the equation and K is computed on the basis of actual gust and airplane characteristics. With respect to the current design of rules of reference 2, the 30 feet-per-second gust at structural cruising speed is an effective gust velocity and corresponds to a true gust velocity of about 50 feet per second at sea level.

In order to illustrate the method of measuring these various gusts, figure 2 shows a portion of an NACA accelerometer record taken during flight in rough air. Vertical deflections of the trace indicate magnitude of the accelerations and the horizontal scale denotes time. Some imagination and experience is required in interpreting some of these records, but ordinarily the large successive peaks in the record would be classified as gusts. The magnitude of the acceleration peaks with respect to the reference

line of unity are read for evaluating the gust velocities and the gradient distance is obtained by measuring the time to reach peak deflection

The NACA accelerometers used for open time scale records of the type shown in figure 2 are used primarily on special gust investigations. In view of the relatively short recording time available with these instruments, other instruments have been used for obtaining data on gust characteristics for operations where longer recording times are required.

A large amount of the available effective gust-velocity data has been obtained from the familiar V-G recorder (reference 3). A sample of the type of record obtained from the recorder is shown in the figure 3. The record consists of an area which is erased from a smoked glass plate by a stylus within the instrument. During flight, changes in airspeed cause the stylus to move horizontally, and changes in acceleration cause the stylus to move vertically. The boundary, or envelope line of the resulting area on the smoked plate, represents the maximum positive and negative accelerations that occurred throughout the speed range for the period of operation. The period covered by the record of figure 3 was about 100 flight hours. The type of record obtained from the instrument does not permit the many small accelerations that fall within the erased area to be identified. The V-G recorder is therefore unsuited for obtaining a statistical count of all the accelerations to a low threshold, such as might be desired for fatigue studies, but only the outstanding large values at any speed can be determined. When these maximum positive and negative accelerations and the corresponding airspeeds from figure 3 are substituted in the gust equation of figure 1, the maximum effective gust velocities encountered by the airplane are obtained.

In order to obtain a statistical count of the accelerations to a low threshold, an instrument called the VGH recorder is used. (See reference 4). This instrument is shown in figure 4. The VGH recorder gives a time history record of airspeed, acceleration, and altitude, from which comes the term VGH recorder. It consists of an acceleration transmitter that is installed near the airplane center of gravity, a recorder base that contains airspeed and altitude units, and a film drum. With the VGH recorder it is possible to obtain approximately 100 flight hours of record with the film supplied with each drum.

As an illustration of the type of record obtained from the VGH recorder, figure 5 shows a portion of a record taken from a

commercial transport during flight in rough air. The time scale is given on the abscissa, and the lower trace is airspeed, the middle trace acceleration, and the upper trace altitude. The fine acceleration peaks are gusts. The peaks are very close together because of the slow film speed used with this instrument. The film could be speeded up, but the recording shown in figure 5 has been found satisfactory for obtaining statistical data from transport operations. In evaluating these records for the loads, the magnitude and number of the acceleration peaks are read. The airspeed is also read for converting the acceleration data to effective gust velocities. From the three traces, the load and gust history of the airplane, together with pertinent operating statistics, such as airspeeds and altitudes flown, can be obtained.

The three types of records described -- the VGH record, the V-G record, and the open time scale record -- are the instruments and methods usually used in taking data. In some cases, where fine details of the gust profile are needed, instruments to measure rapid changes in indicated airspeed, or angle of attack variations, are also used.

Samples of data on gust intensity and gradient distance are shown in figure 6 (from reference 1), in which intensity of gust is plotted as the ordinate, and average gradient distance as the abscissa. The average gradient distance is used to obtain a representative value for the spread that is usually measured for any gust velocity. It may be noted that the gradient distance in figure 6 is given in terms of airplane wing chord rather than in feet. Gradient distance is usually expressed in this manner because of all gusts in the atmosphere, the size of significant gusts is selected by the airplane on the basis of the airplane size. This selecting process of airplanes is analagous to the case of large and small boats on the ocean. It is apparent that the short or choppy waves that toss a rowboat around do not affect the motions of a large battleship. Conversely, the long-period swells that make rough going for the battleship give only gentle vertical motions to the rowboat. The airplane reacts in a similar manner to the disturbances in the atmosphere. In figure 6, then, in which data have been plotted for airplanes varying in size from the Aeronca with a chord of 4 feet to the XB-15 with a chord of 18 feet, it maybe seen that the gradient distances in chords tend to fall within a band and increase somewhat as gust intensity increases. The curve in the figure was drawn to agree best with the XC-35 data which is considered the most extensive sample. In view of the large variation in the size of the airplanes, it is felt that the relation provides a suitable basis for relating gust size to airplane size.

Other characteristics of gusts not illustrated in figure 6 are that, on the average, the velocity components in the three directions are the same. In addition, gusts are randomly distributed according to size and intensity in any stretch of rough air. While an individual gust can have any conceivable shape, both in the longitudinal and spanwise directions, a shape as was shown in the first figure is generally assumed in treating large masses of data. The number of gusts and their intensities vary with the weather encountered, and so far as is known, the number would decrease with altitude.

The second part of the problem of repeated gust loads, which relates to the influence of airplane characteristics on the loads, will now be discussed. For the ideal case given by the gust equation (fig. 1), airplane characteristics were represented simply by the K factor, slope of the lift curve, and wing loading. In the actual case, the loads are influenced by many other factors.

One of these factors is the potential effect of variations in piloting technique on the loads during flight in gusty air. Some special tests on the effect of piloting technique on gust loads indicate that the loads may be increased from 5 to 20 percent if the pilot attempts to correct for all the disturbed motions of the airplane in rough air rather than correcting for only the major disturbances.

Another factor is the effect of center of gravity location on gust loads. Both analytical and experimental work have indicated that the gust loads are decreased by about 2 percent for each one percent forward shift of the center of gravity.

The factor in gust response of airplanes that has probably received the most attention recently is the effect of airplane elasticity on the loads and stresses. It is well known that under transient conditions, vibrations of the structure can cause higher stresses than would be obtained from the same load applied under static conditions. Data on the magnitude of these vibrational effects were recently obtained from strain gages and accelerometers mounted at the center of gravity and at different points along the wing span of a modern transport airplane (reference 5).

Records taken in rough air showed dynamic response effects by vibrations from the wing on the records. Figure 7 presents some of the acceleration data as an indication of these effects, which are borne out by the stress measurements as well. In figure 7 peak acceleration for individual gusts as measured at

the center of gravity of the airplane is plotted as the ordinate. The accelerations at the wing nodal points were found to be free from the effects of primary vibrations. These values were taken as a measure of the applied load and are plotted as the abscissa.

Inspection of figure 7 indicates that local accelerations at the center of gravity were higher than the nodal-point accelerations by about 20 percent or more. This amplification of the center of gravity measurements due to wing vibrations gives evidence of significant dynamic response effects for modern airplanes. These effects of the wing vibrating when loads are rapidly applied are continually being investigated.

The final part of the repeated loads problem is concerned with the influence of operating conditions on the loads. It is evident that the operating conditions, such as weather encountered or route flown, determine the gusts that are encountered. It is also evident that the loads from these gusts depend on other operating variables, such as flight speed. With the use of different types of equipment by the airlines on different routes many combinations of operating variables can exist. Because the gusts and loads are influenced by these variables, isolated research flights cannot be expected to produce data that can be generalized. The only method of obtaining statistically reliable information on the repeated loads actually experienced by the airplane is the collection of data from service airplanes.

These data are collected with the V-G and VGH recorders, which have been described. In order to illustrate how some of these records are considered, take another portion of a VGH record. In this record (fig. 8) the airspeed and altitude traces have been deleted and the record has been enlarged so that many of the individual accelerations can be seen. Much of the detail has been lost, but it can be seen that the record consists of a random series of positive and negative accelerations of different magnitudes. When these peaks are evaluated for effective gust velocities, the gust history of the airplane is therefore a series of gusts of different intensities. The first step in obtaining some sort of a picture of this series of gusts is to count the number of gusts that have given intensities. Thus, for a given record there might be a hundred small gusts, below a quarter g increment, that are in the solid black regions, and only a few of the large values over 1/2 g increment. Actually, the count is made to a finer division of gust intensities, and if these numbers are plotted, a frequency distribution is obtained.

This type of count has been used to determine differences in the gust experience for different types of operations, for instance in comparing high- and low-altitude flights.

Since a count of the gust velocities, such as that described, shows that small gusts are much more frequent than those of large value, the average number of miles flown for the occurrence of a small gust is low as compared to the average number of miles before a large gust is to be expected. Using this concept of average miles flow before given gust values would be expected, the frequency distributions are transformed into what are called miles-to-exceed curves to give an indication of the loads. Typical examples of these curves for special research flights in such conditions as thunderstorms and low-level clear-air turbulence are shown in figure 8.

For these curves, gust velocities are plotted as the ordinate, and the logarithmic scale of the abscissa represents the average number of miles that would be flown before gusts of given intensities would be encountered. The plot may be considered as representing the chance of encountering different gust intensities in terms of miles of flight. The plot has no significance as to the order in which different gusts may be encountered and does not imply that for the thunderstorm sample a 16-foot-per-second gust was measured in the 10th mile or a 24-foot-per-second gust in the 100th mile. In fact, the 24-foot-per-second gust might have been experienced in the first mile. The mileage scale represents only the likelihood of that gust being encountered.

The curve shown in figure 9 for transport operation in rough air represents a combination of distributions for all types of weather since commercial airplanes fly under all combinations of weather. The transport curve may thus represent 2-percent thunderstorm flight, 30-percent clear air turbulence, 20-percent stratus clouds, etc. It has not been found possible, however, to define given operations by the proportion of time spent under various weather conditions, and in order to obtain the required loads data, it is necessary to take the measurements during flight of commercial transport airplanes.

In summary, the repeated gust loads problem embraces different aspects of the characteristics of atmospheric gusts, airplane reaction to these gusts, and incidence of gusts encountered in various types of operation. Information obtained to date has been

the basis for much of the current gust-load requirements, although changes in airplane design and operation conditions are accompanied by many new gust load problems. Continued research, particularly in reference to higher operating altitudes, is in progress.

REFERENCES

1. Donely, Philip: Summary of Information Relating to Gust Loads on Airplanes. NACA TN 1976, 1949.
2. Anon.: Airplane Airworthiness. Civil Aero. Manual 04, CAA, Feb 1, 1941.
3. Rhode, Richard V.: Gust Loads on Airplanes S.A.E Jour. (Trans.), vol. 40, no. 3, March 1937, pp. 81-88.
4. Steiner, Roy, and McDougal, Robert L.: Summary of Normal Accelerations, Gust Velocities, and Operating Practices from April to August 1949 on a Twin-Engine Airplane in Commercial Transport Operations. NACA RM L50B02, 1950.
5. Shufflebarger, C. C., and Mickleboro, Harry C.: Flight Investigation of the Effect of Transient Wing Response on Measured Accelerations of a Modern Transport Airplane in Rough Air. NACA TN 2150, 1950.

$$\Delta n = \frac{\Delta L}{W} = K \frac{\rho \frac{dC_L}{da} UV}{2 W/S}$$

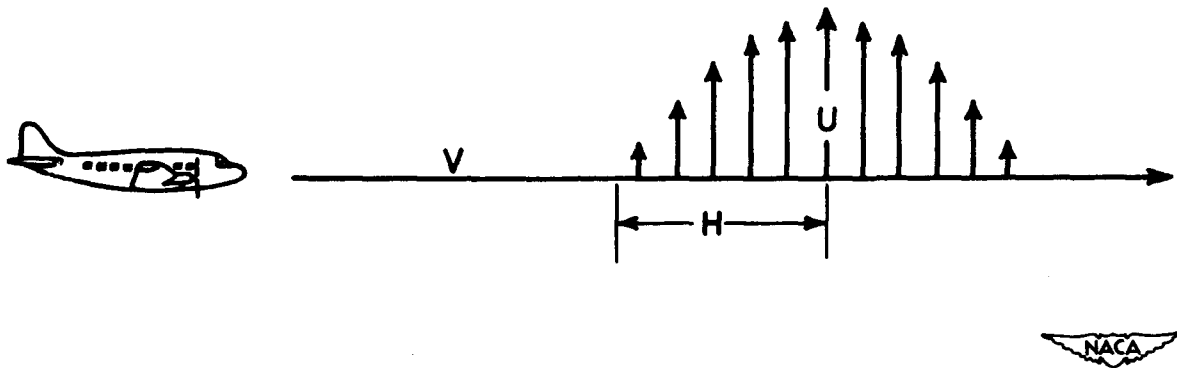

Figure 1. - Simple gust concepts.

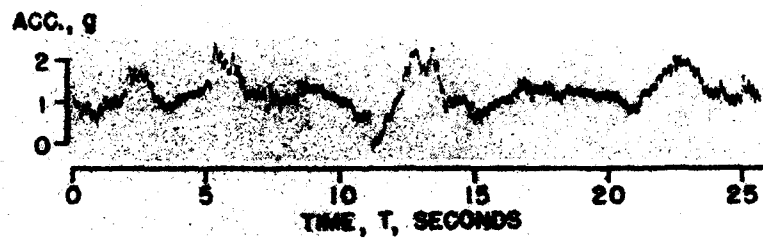

Figure 2. - Record from NACA recording accelerometer.

ACCELERATION,
g UNITS

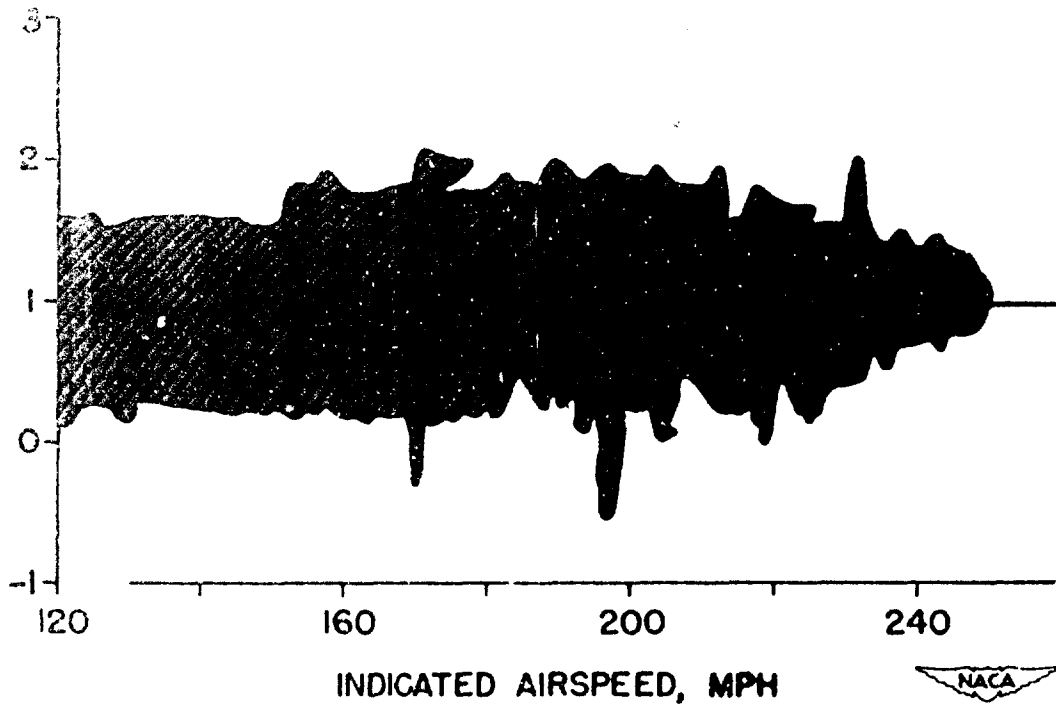

Figure 3. - Sample V-G record.

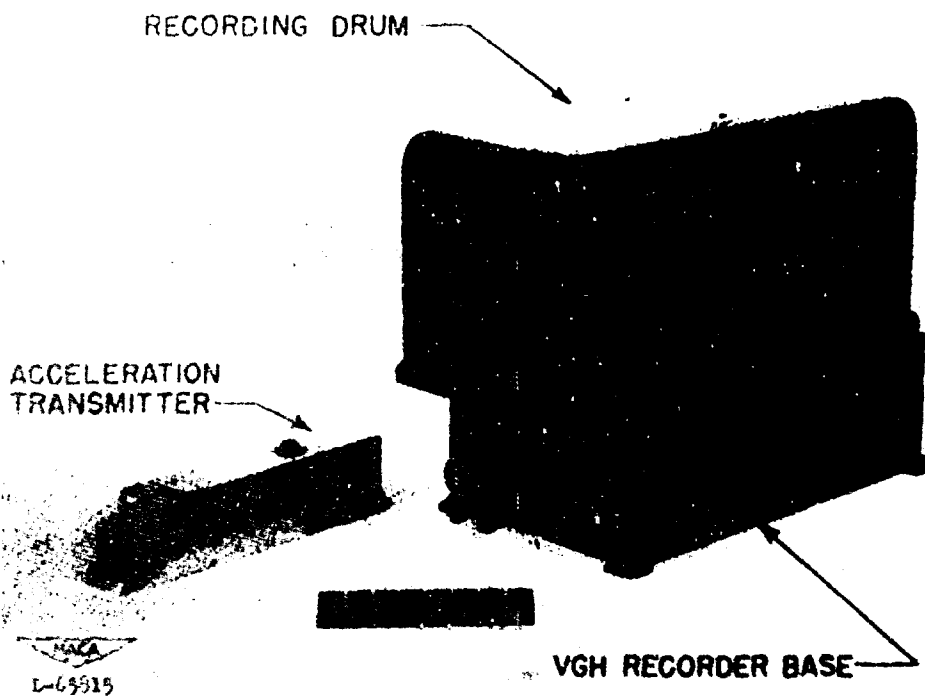

Figure 4. - The NACA VGH recorder.

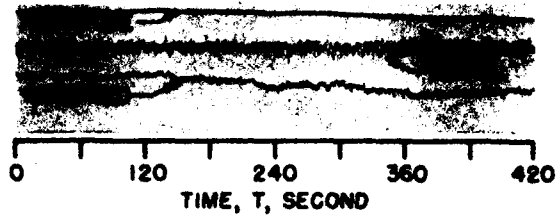

Figure 5. - Record from NACA VGH recorder.

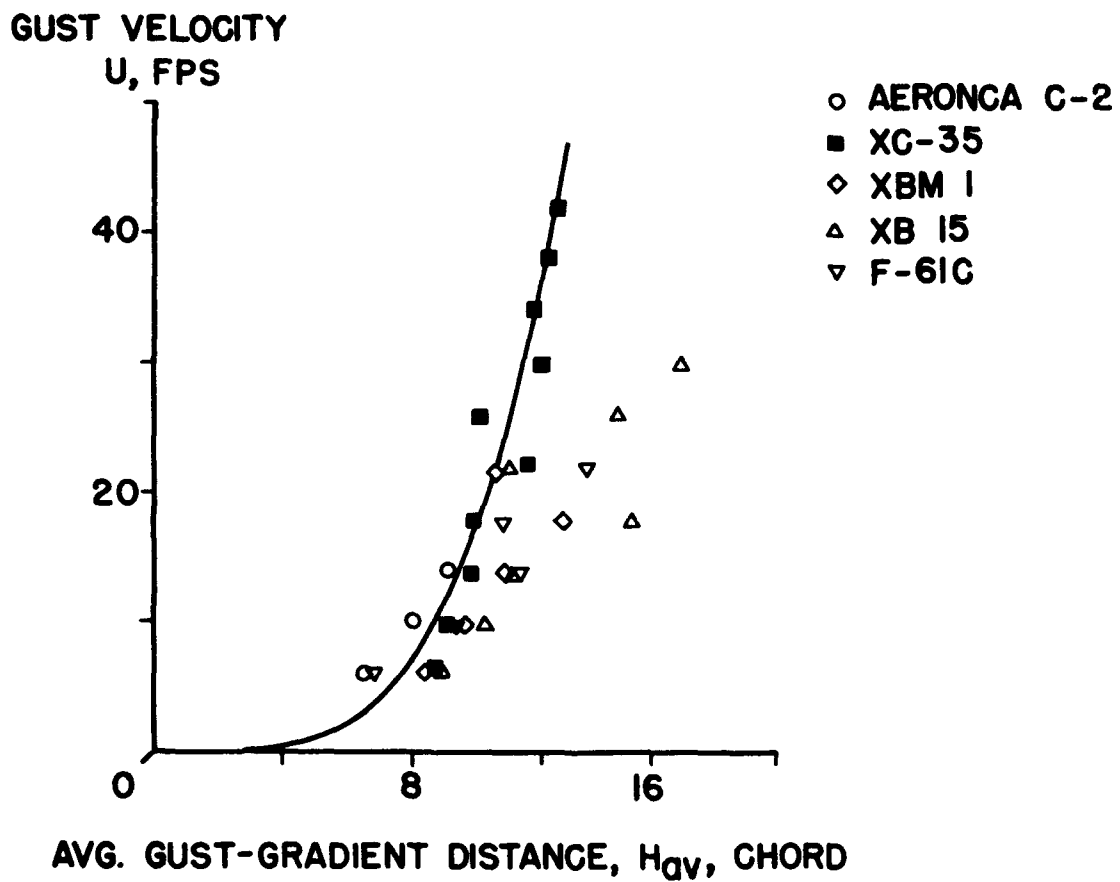

Figure 6. - Sample of gust structure data.

SECRET

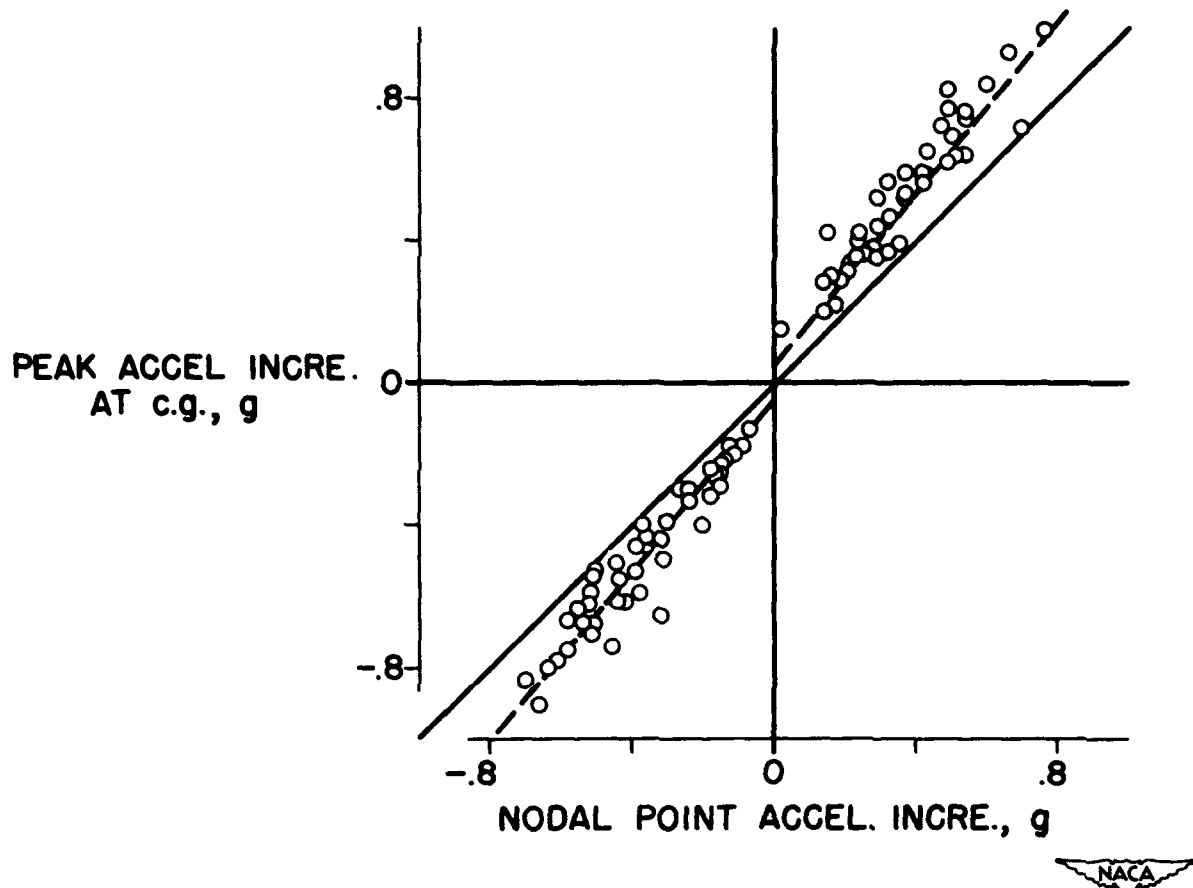

Figure 7. - Dynamic response effects.

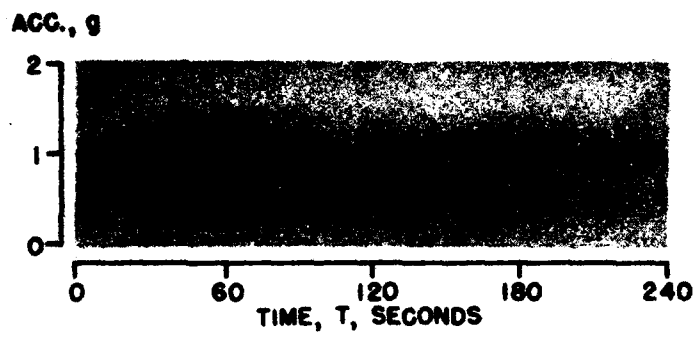

Figure 8. - Enlarged VGH accelerometer record.

SECRET

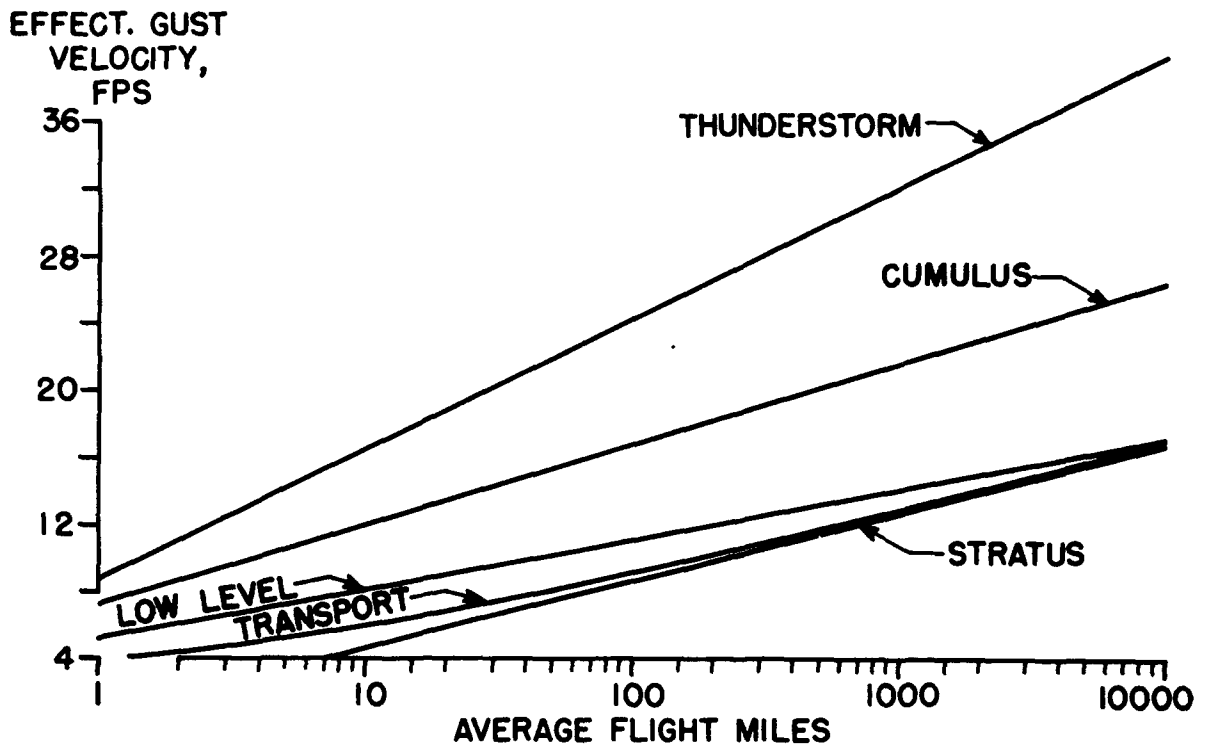

Figure 9. - Gust velocity frequency distributions.

3. GUST-LOAD EXPERIENCE IN TRANSPORT OPERATIONS

By John R. Westfall and Roy Steiner

ATMOSPHERIC TURBULENCE AND ITS EFFECT

ON AIRCRAFT OPERATION

3. GUST LOAD EXPERIENCE IN TRANSPORT OPERATIONS

By John R. Westfall and Roy Steiner

Langley Aeronautical Laboratory

In the flight operation of transport aircraft, atmospheric gusts constitute a principal source of loads. These loads might be, for convenience, put into two main categories: one is the large but relatively infrequent load which may cause structural damage or failure by a single application. The other is a smaller load which, in itself, will not cause failure, but because of its greater frequency of occurrence, affects airplane fatigue life and passenger comfort. A knowledge of the magnitude and frequency of both types of loads and of the factors which influence them, is of concern to the airline operator.

The number and intensity of gust loads imposed on an airplane is influenced by certain operating conditions and practices such as airspeed, altitudes flown, route, and season. The best way known to obtain data on the effects of these factors is to measure the loads and associated operating conditions on airplanes in routine commercial flights. To do this, the NACA utilizes two instruments, the V-G recorder and the VGH recorder. It is impossible to predict the gust loads experience of any given airplane on an absolute or precise basis since in transport operations there exist a great many possible combinations of gust intensity, frequency, and sequence, airplane speed, altitude, terrain effects, and so forth. An airplane's gust load experience can be predicted, however, on a statistical or average probability basis.

Where statistics are involved one question that immediately arises concerns the amount of data necessary to achieve a desired accuracy of reliability. The answer to that question, of course, largely determines the sample size to be taken and scope of the programs of V-G and VGH record collection. In statistical analysis, the reliability of the results depends primarily on the number of measurements. In any sample of gust loads data, the number of measurements of different values of acceleration may vary unduly, as illustrated by figure 1. These data were obtained from about 700 hours of VGH records from one set of operations. The number of accelerations of a given value is the ordinate, plotted on a logarithmic scale, and the magnitude of acceleration increment, in g units, is the abscissa. A value of 0.3g was taken as the reading threshold

because smaller values were hard to read from the cramped time scale of the VGH records so that the count of the smaller values of acceleration probably would be inaccurate. It is evident that the frequency of occurrence decreases drastically as we go from 0.3g to the higher values of loading. For example, there are some 14,000 accelerations of 0.3g, but only about 200 of 0.6g, and only 5 equal to 1.0g. It is apparent therefore that with so few points the reliability of the data for the higher values of acceleration is much less than that for the smaller values. Assume it is desired to determine the loads which the airplane will experience, over a range of accelerations from 0.3g up to the limit load factor increment (1.5 to 2g). If a reliability of the distribution of the large loadings comparable to that given by 14,000 readings at 0.3g were desired, it would require about 70,000 hours of data from each route or set of operations instead of 700.

It is not necessary, however, to collect and analyze such large masses of VGH data to obtain a complete distribution of gust loads for any set of operations. A more practical method is to supplement a moderate amount of VGH data with large quantities of V-G data, which are relatively simple to obtain and analyze. The method of combining VGH and V-G data to yield the gust loads distribution is shown in figure 2. Acceleration increment in terms of g is plotted as the ordinate, and the number of miles which must be flown to encounter a given value of acceleration increment is the abscissa, plotted on a logarithmic scale. It should be pointed out that each symbol does not necessarily represent a single measurement but rather represents a single point on a frequency distribution curve such as shown in figure 1. In other words, each symbol may represent a few or a great many measurements. The VGH data, shown by the circles, were obtained from about 170,000 miles of flight, which is believed to be adequate to give the desired reliability over the lower part of the curve, up to values of say 0.8 or 0.9g. At higher g's, the number of measurements from the VGH data is too small to give the desired reliability. The V-G data, shown by the squares, were obtained from about 8,000,000 miles of flight. The reliability of the V-G data is likewise not too good in the region of intermediate values of g, since while these values may stand out as peaks on some records, they will be obscured on others by the superimposing of larger loads at the same airspeed and hence the count is likely to be too small. The higher values of load, say above 1.5g, are not likely to be obscured in the V-G envelope, so that the count of these values is good. At the extreme upper end of the curve where the number of loads is small, there may be some deviation from the general pattern of the distribution, as illustrated by this point which is a single maximum load. While such points are true values, they cannot be given as much weight in fairing the curve as others which occur more frequently.

Data such as these are of value in many respects. As has already been pointed out, the information they give with regard to repeated loads has a bearing on the fatigue problem. Even though it is not yet possible to make an accurate quantitative analysis of the fatigue life of an airplane, the data permit studies of the relative effects on fatigue of some design and operating parameters. Such data can be used to determine the effect on fatigue life of one important operating variable, namely, speed in rough air.

In figure 3 the same data shown previously have been transposed into somewhat different form. The magnitude of the acceleration increment is the ordinate, and the number of times a given value of acceleration increment was equalled or exceeded is the abscissa, plotted on a logarithmic scale. The upper curve represents the distribution of acceleration increments which could be expected if the airplane operated at normal cruising speed (in this case 200 mph) at all times, in rough air as well as smooth. From well established relationships such as those described in the preceding paper (Part 2), the reduction in load and load frequency for any given reduction in airspeed can be calculated. Results of such calculations are shown in the two lower curves. The middle curve represents the situation when the airspeed is reduced 5 percent in rough air, or from 200 mph to 190 mph. The magnitude of all loads is reduced by 5 percent, but the number of loads of a given magnitude is reduced about 30 percent. If the speed is reduced by 20 percent, or from 200 mph to 160 mph, the magnitude of all loads is reduced 20 percent, but the frequency is reduced 80 percent. Two apparently identical airplanes may have a difference of several hundred percent in their respective fatigue lives - one may have a fatigue life of two years and another a life of 10 or 15 years. Assume the use of an airplane which would have a fatigue life of six years if it were operated at its normal cruising speed at all times. If the airspeed is reduced only 5 percent in rough air, the fatigue life will be increased from six years to nearly eight. A speed reduction of 20 percent in rough air might extend the fatigue life to nearly 30 years.

Besides indicating the nature of the over-all frequency distribution of gust loads, VGH data disclose a number of other important facts relating to the detailed load experience under actual operating conditions. Figure 4 presents, in tabular form, some of the information that can be obtained. The data are from some 700 hours of flight. The flight operations have been evaluated in terms of time spent in three flight conditions; climb, en route, and descent, and each of these in turn is subdivided into smooth and rough air. Rough air was defined as any portion of the flight path in which acceleration increments greater than $\pm 0.3g$ were encountered. The table also shows the average speed in rough and smooth air for the three flight conditions, so that the effectiveness of

speed reduction in terms of relative fatigue life can be studied. Other information includes the maximum loads encountered, and the load frequencies.

In the lower table the data are evaluated in terms of percent of flight path for different altitude brackets. It can be seen that in this particular sample the greater part of the operations was at altitudes less than 5000 feet above terrain, which probably accounts for the relatively high percent of time spent in rough air.

Samples of gust load frequencies available at this time are largely confined to low-altitude operations such as typified by the data in figure 4. It is of great importance that similar samples be obtained for operations at higher altitudes, in order that the effect of altitude on the gust loads experience of present and future high-altitude transports may be appraised. Designers have hoped that the frequency of gust loads might be substantially less at the higher altitudes than at the lower altitudes. This seems like a fairly reasonable assumption since at the higher altitudes the airplane avoids some turbulence associated with convective-type cloud formations, and also the mechanically-generated type of turbulence associated with surface winds and rough terrain. At present there is available only a small sample of VGH data taken on one high-altitude airplane. The trends indicated by these data should not, therefore, be taken as well established. In figure 5 altitude in thousands of feet is plotted against the number of accelerations per 100 miles of flight from a sample of 120 hours of VGH data. As can be seen, the frequency of loads decreases rather markedly as the altitude increases. The short section of data at the right is from low-altitude operations of another airplane over roughly the same route, and may be regarded as a partial check on the load experience of the high-altitude airplane when it was operating at the lower levels.

Little has been said here about V-G data other than to point out that these data, in effect, supplement the VGH data by providing frequency distributions of the larger and less frequent gust loads. Besides thus extending the picture on repeated loads, the V-G data serve to establish the probability of occurrence of the large single loads that may cause failure of the airplane structure by simple overloading - a type of failure which has nothing to do with fatigue. V-G data also show the maximum speeds encountered under actual operating conditions, which is a matter of considerable structural importance.

As with repeated loads, the probability of encountering single large loads depends upon a number of operational factors. These include route, season, dispatching practices, forecasting, and piloting practices, especially speed reduction in rough air and circumnavigation of large

cumulus clouds. An illustration of the type of information obtained from analysis of V-G records may be of interest. The difference in gust experience for airplanes of the same type, flown by the same operator but over different routes, a trans Pacific and a Caribbean - South American route is shown in figure 6. Effective gust velocity in feet per second is plotted as the ordinate, and the number of miles to equal or exceed a given value of gust velocity is the abscissa, plotted on a logarithmic scale. Gust velocity instead of acceleration was used as a criterion of roughness to eliminate any effects of differences in operating speeds and weights. For a given number of miles flown, the Pacific route was less rough, by about 15 percent. Analysis of data from routes in various parts of the United States indicates that, all things considered, there may be a difference of 5 to 10 percent in the gust loads experienced by airplanes flying in different parts of the country.

In conclusion, the determination of both repeated gust loads and single large loads under actual operating conditions is of importance to the designer and the operator of transport airplanes. Both the V-G recorder and the VGH recorder are essential to such load determinations, as these instruments are complementary to each other. Data collection must be a continuing process, because operating conditions change and the loads experienced are affected to an important extent by these changes.

REFERENCES

1. Peiser, A. M., and Wilkerson, M.: A Method of Analysis of V-G Records from Transport Operations. NACA Rep. 807, 1945.
2. Peiser, A. M., and Walker, W. G.: An Analysis of the Airspeeds and Normal Accelerations of Boeing S-307 Airplanes in Commercial Transport Operations. NACA TN 1141, 1946.
3. Walker, Walter G., and Hadlock, Ivan K.: An Analysis of the Airspeeds and Normal Accelerations of Boeing B-247 and B-247D Airplanes in Commercial Transport Operation. NACA TN 1783, 1948.
4. Pross, Harry: The Application of the Statistical Theory of Extreme Values of Gust-Load Problems. NACA TN 1926, 1949.
5. Steiner, Roy, and McDougal, Robert L: Summary of Normal Accelerations, Gust Velocities, and Operating Practices from April to August 1949 of a Twin-Engine Airplane in Commercial Transport Operations. NACA RM L50B02, 1950.
6. Coleman, Thomas L.: An Analysis of the Normal Accelerations and Airspeeds of Several Lockheed Constellation L-649 Airplanes in Postwar Commercial Transport Operations over the Eastern Part of the United States. NACA RM L9E18a, 1950.

7. McDougal, Robert L.: Summary of the First Sample of VGH Data of Normal Accelerations and Associated Operating Conditions on Two Four-Engine Transport Airplanes in Commercial Operations. NACA RM L50D28a, 1950.
8. Coleman, Robert L., and Schumacher, Paul W. J.: An Analysis of the Normal Accelerations and Airspeeds of a Four-Engine Airplane Type in Postwar Commercial Transport Operations on Trans-Pacific and Caribbean-South American Routes. NACA TN 2176, 1950.

BIBLIOGRAPHY

- Walker, Walter G.: Summary of V-G Records on Transport Airplanes from 1932 to 1942. NACA RB, July 1942.
- Rhode, Richard V., and Donely, Philip: Frequency of Occurrence of Atmospheric Gusts and Related Loads on Airplane Structures. NACA ARR IAI21, 1944.
- Putnam, Abbott A.: An Analysis of Life Expectancy of Airplane Wings in Normal Cruising Flight. NACA Rep. 805, 1945.
- Steiner, Roy, and Peiser, A. M.: An Analysis of Airspeeds and Mach Numbers Attained by Lockheed Constellation Airplanes in Trans-Atlantic Operation During the Spring of 1946. NACA MR L6G09a, 1946.
- Peiser, A. M.: An Analysis of the Airspeeds and Normal Accelerations of Douglas DC-3 Airplanes in Commercial Transport Operation. NACA TN 1142, 1946.
- Walker, Walter G.: An Analysis of the Airspeeds and Normal Accelerations of Martin M-130 Airplanes in Commercial Transport Operation. NACA TN 1693, 1948.
- Walker, Walter G.: An Analysis of the Airspeeds and Normal Accelerations of Sikorsky S-42A Airplanes in Commercial Transport Operation. NACA TN 1733, 1948.
- Walker, Walter G.: An Analysis of the Airspeeds and Normal Accelerations of Douglas DC-2 Airplanes in Commercial Transport Operation. NACA TN 1754, 1948.
- Port, W. G. A.: High Altitude Gust Investigation. Rep. AERO. 2341, British R.A.E., Nov. 1949.
- Starkey, R. D.: Analysis of the Accelerations and Speeds Recorded on B.O.A Constellation Aircraft. Tech. Note Structures 48, British R.A.E., Oct. 1949.
- Wills, H. A.: The Life of Aircraft Structures. Paper presented before Secc Int. Cong. I.A.S.-R.Ae.S. (New York), May 23-Jun. 5, 1949. (Abs. in Acro. Eng. Rev., vol. 8, no. 8, Aug. 1949, pp. 25.26.)

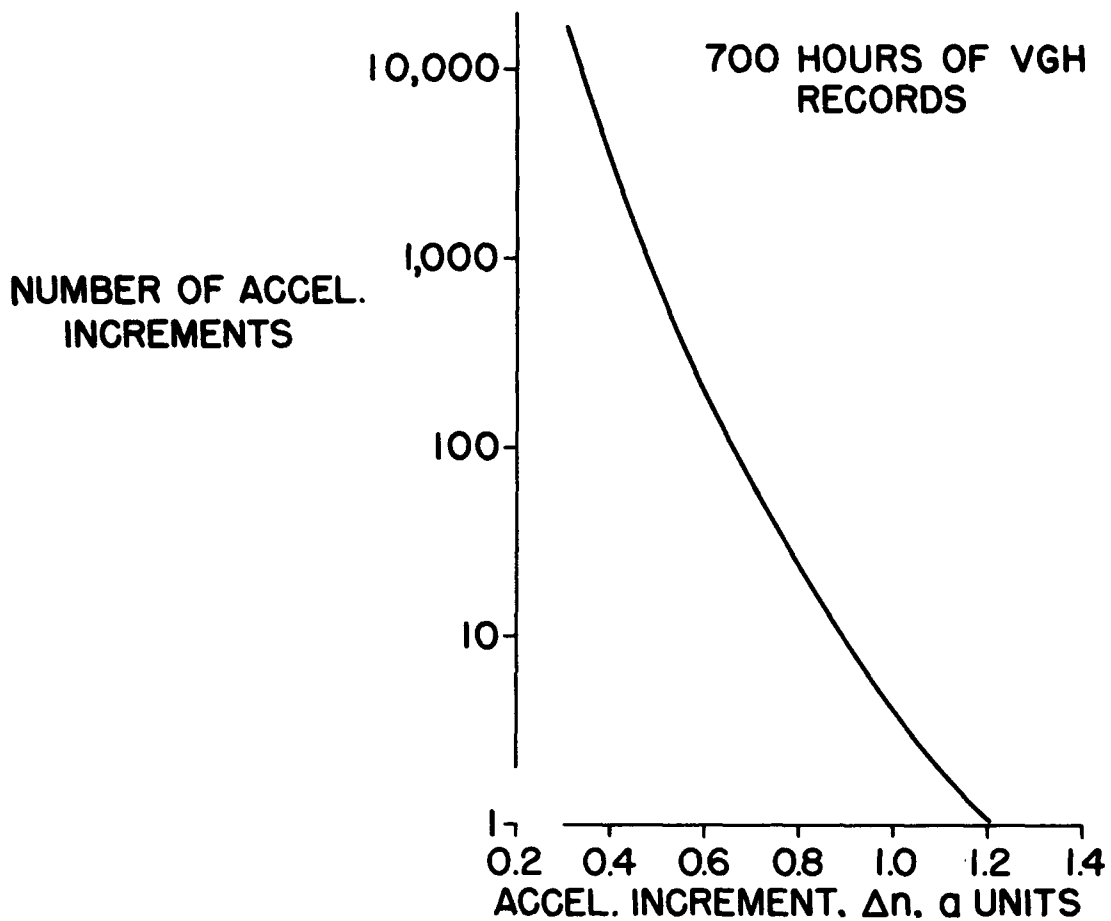

Figure. 1 - Frequency distribution of acceleration increment from 700 hours of VGH records.

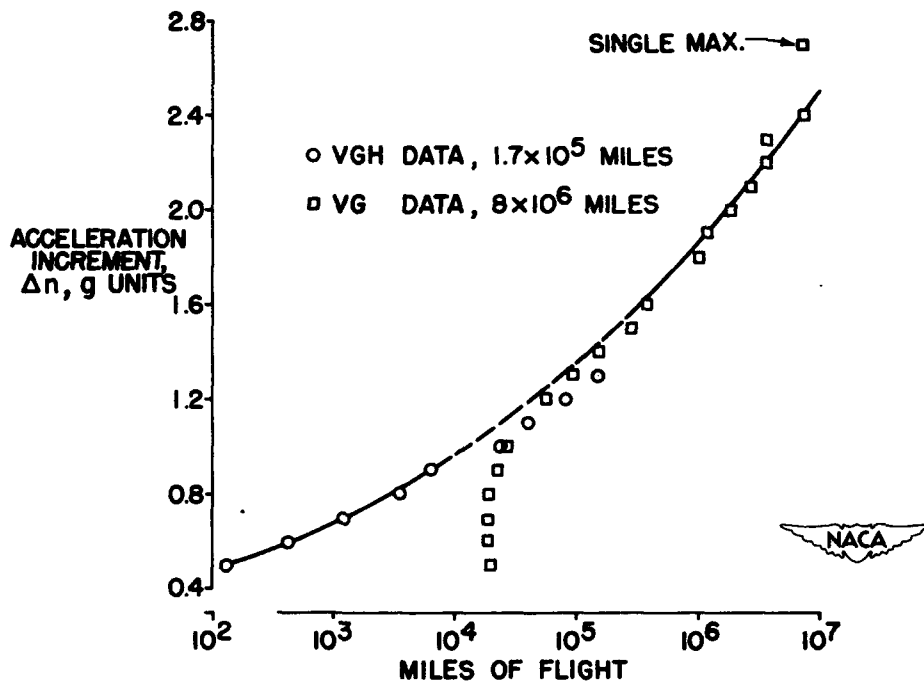

Figure 2. - Method of combining VG and VGH data to obtain complete distribution of gust loading.

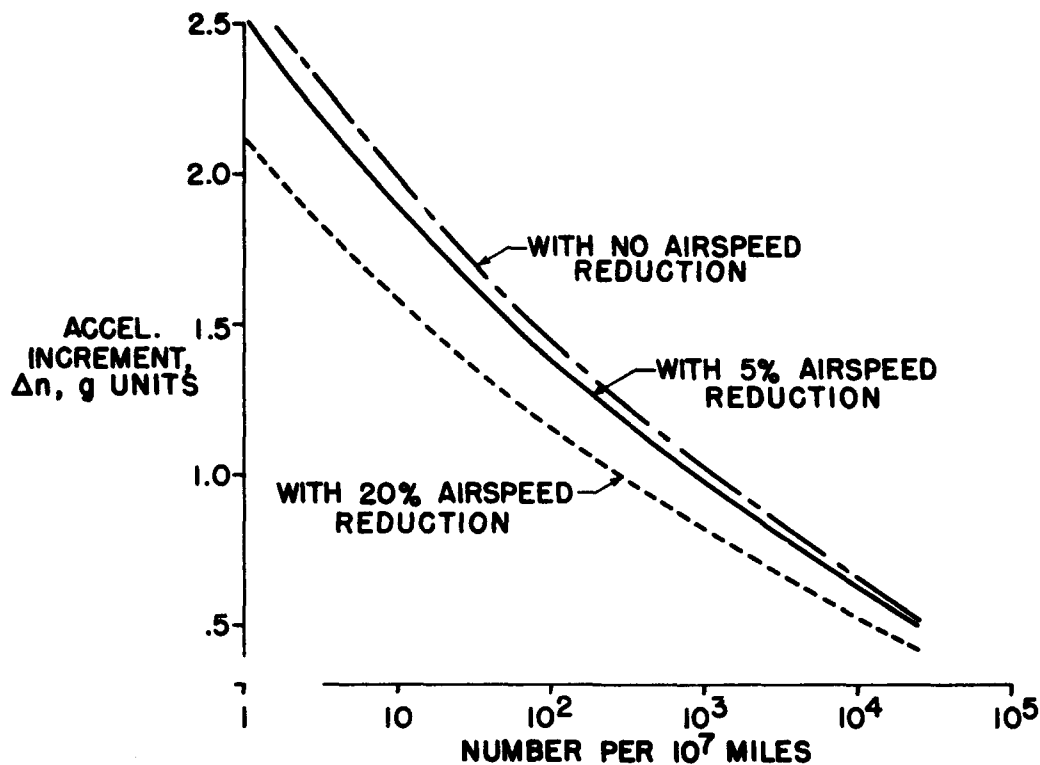

Figure 3. - Effect of speed reduction in rough air on load frequency.

SUMMARY OF VGH DATA FROM ONE AIRLINE FOR 712 HRS OF LOW ALTITUDE OPERATION

(a) GUST LOADS AND AIRSPEED EXPERIENCE

FLIGHT CONDITION	FLIGHT DISTANCE (MILES)		PERCENTAGE OF FLIGHT PATH IN ROUGH AIR	AVG. INDICATED AIRSPEED (MPH)		MAX. Δn (g UNITS)	NO. OF Δn 's $\geq \pm 0.3$ g	NO. OF Δn 's $\geq \pm 0.3$ g PER MILE OF ROUGH AIR
	ROUGH	SMOOTH		ROUGH	SMOOTH			
CLIMB	4078	6999	36.82	167.0	165.2	+1.38	1630	0.3997
ENROUTE	20686	72115	22.29	204.3	212.0	+1.20	8181	0.3955
DESCENT	18463	21771	45.89	190.0	204.9	-1.02	8867	0.4804
TOTAL	43227	100885	-	-	-	-	18678	-
AVERAGE	-	-	30.00	194.0	206.4	-	-	0.4322

(b) PERCENTAGE OF FLIGHT PATH BY ALTITUDE ABOVE TERRAIN AND TURBULENCE CONDITION (ALT x 10³ FT).

FLIGHT CONDITION	0-5		5-10		10-15	
	ROUGH	SMOOTH	ROUGH	SMOOTH	ROUGH	SMOOTH
CLIMB	2.63	4.14	0.19	0.72	-	-
ENROUTE	9.39	26.93	4.97	23.07	0.03	0.02
DESCENT	11.69	12.95	1.11	2.15	-	0.01
TOTAL	23.71	44.02	6.27	25.94	0.03	0.03

Figure 4



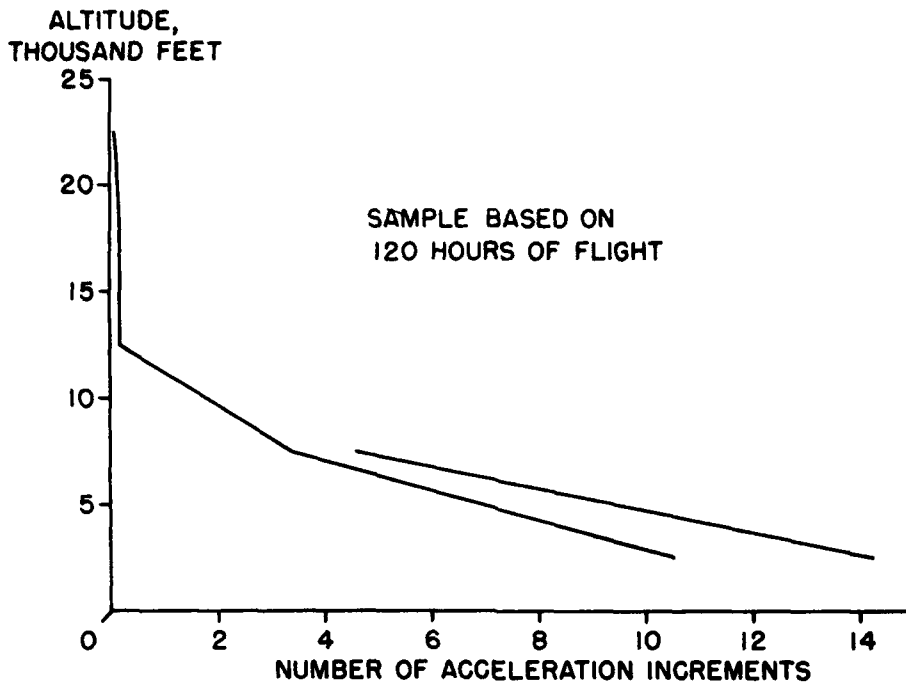

Figure 5. - Variation of gust load frequency with altitude.

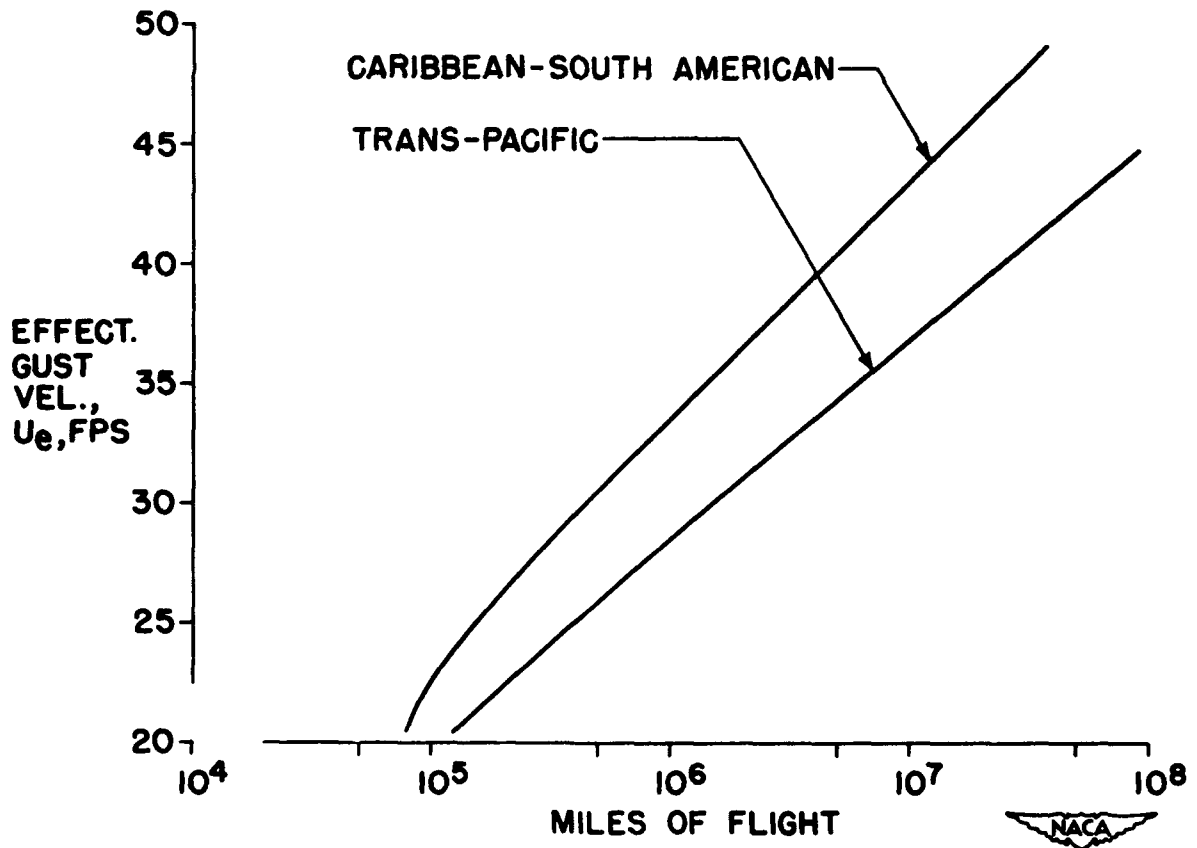

Figure 6. - Effect of route on gust frequency.

4. THE DETECTION AND FORECASTING OF TURBULENCE

By James K. Thompson

ATMOSPHERIC TURBULENCE AND ITS EFFECT ON AIRCRAFT OPERATION

4. THE DETECTION AND FORECASTING OF TURBULENCE

By James K. Thompson

Langley Aeronautical Laboratory

Previous papers have discussed the problem of repeated gust loads and have indicated that satisfactory methods for reducing the gust-load experience of the airplane are desirable for both future and present transport operations. One method of reducing gust-load experience of the airplane is through choice of a flight altitude and path that will avoid turbulent regions. The methods considered here are the prediction and detection of the location and intensity of regions of atmospheric turbulence.

Although methods for predicting the location and intensity of atmospheric turbulence have been studied for many years, little success has been obtained because of the complicated nature of physical processes in the free atmosphere. The meteorologist usually simplifies the problem by treating the intensity of turbulence according to the predominate source of energy. Thunderstorm turbulence for example, is usually analyzed according to some measure of the buoyant forces within the storm. The methods of prediction now available are simple empirical relations based on observations of turbulence intensity and meteorological factors. Although the methods do not permit precise forecasts of both the location and intensity of atmospheric turbulence, they do provide some estimate of the intensity of turbulence that may be encountered by airplanes operating in the region of thunderstorm activity or at low altitudes in clear air.

Low-level clear-air turbulence is seldom critical from the standpoint of single excessive gust loads. Such turbulence is significant, however, to the fatigue life of the airplane and to passenger comfort. This clear-air turbulence is associated with atmospheric flow over the earth's surface and is located in a layer usually extending to an altitude of about four thousand feet. Data obtained from a recent flight investigation in Ohio have been utilized by NACA to continue past studies of the gust experience of airplanes operating in this turbulent layer. One of the quantities examined in the study was the product of total solar heating received on a unit horizontal surface during the flight day and average wind shear. Wind shear is defined here as the rate of change with altitude of wind direction and velocity in the turbulent layer. The product of these two variables was found to yield reliable estimates of the gust experience of an airplane operating at low altitudes under certain conditions.

A measure of observed gust experience as a function of this index of clear air turbulence is shown in figure 1. The ordinate is gust velocity and the abscissa (turbulence index) is the product of wind shear and solar heating. Each of the points represent one of twenty-three flights made by the airplane during spring, fall, and winter seasons. The solid line represents the line of best fit determined by a method of least squares and the dashed lines define the error band. About two thirds of the observations may be expected to fall between these error bands.

The figure shows that the average maximum effective gust velocity per mile of flight was usually determined within less than one foot per second and that the meteorological index of turbulence intensity is related to the gust experience of the airplane for the best conditions. The relation has been obtained empirically and direct application of the results to other regions is not warranted. The value of the index for other localities is for the purpose of estimating the relative intensity of low-level clear-air turbulence under certain conditions.

The index may be used to best advantage in connection with studies of airplane behavior if flights are to be made in clear air at low altitudes and over a given route or area. For this type of an investigation, the index has enabled NACA engineers to determine if the prevailing turbulence is apt to be sufficiently intense to warrant preparation for test operations. Further investigations are required before meteorological predictions may be utilized to enable any significant reduction in the gust experience of the transport airplane.

Large cumulus and thunderstorm clouds represent an important source of intense atmospheric turbulence. The clouds may form randomly throughout an air mass or in lines along frontal zones. Gust velocities greater than those for which transport airplanes are designed are known to occur in these regions.

The results obtained from an investigation of a method for predicting maximum effective gust velocity in thunderstorms are presented in figure 2. The ordinate is the maximum effective gust velocity encountered by an airplane during a large number of flights through a thunderstorm. The abscissa is the predicted maximum relative horizontal temperature difference between the warmest and coldest air of the thunderstorm. The points represent twenty-nine thunderstorms that were investigated. The solid line is again the line of best fit determined by a method of least squares and the dashed lines define the error band.

The index of thunderstorm turbulence is apparently related to the maximum gust intensity of the thunderstorms. The error band shows that

the maximum effective gust velocity is usually predicted within about five feet per second. Although the quality of the relation is not as good as that of figure 1, the index has been determined from data that would be available to field personnel for making the flight forecast. A part of the error is obviously connected with errors in forecasting the temperature difference in the storm. The errors are representative therefore of those that would be made by a forecaster. This index of thunderstorm turbulence represents one step in the development of a method for determining if gust velocities greater than that for which the airplane was designed are likely to be present in the storm. It does not however, attempt to predict the intensity of turbulence that will actually be encountered on any single flight through the thunderstorm.

A reduction of the gust experience of the airplane may also be obtained by utilizing devices for detecting the location of regions of atmospheric turbulence. Of the methods investigated by different agencies, radar probably holds the only reasonable chance of success in the immediate future. Radar is not a true detector of turbulence however, and its use depends upon the existence of relations between turbulence and the water content of clouds.

The 10-centimeter ground radar, the 3-centimeter airborne radar, and the 3-centimeter airborne radar with an attachment for indicating areas of light and of heavy rain, have been investigated for possible use in detecting the turbulent regions of thunderstorms. The investigations represent the cooperative work of the Navy, Air Force, American Airlines, and NACA. The results of these investigations may be more easily discussed if some elements of thunderstorm structure and radar principles are first considered. An outline of the rain core and visible cloud of a large thunderstorm is shown in figure 3. The hatched area represents the rain core of the storm and the white area represents portions of the storm in which the water content is low and the drops are small. A projection of the horizontal area of the rain core onto the earth's surface is also shown.

The rain core of a thunderstorm such as this contains a multitude of tiny reflecting surfaces and may be considered as an echo source. A portion of a radar signal directed into the storm from some exterior position will be reflected as an echo to the radar set. The direction and distance from the radar set to the reflecting surfaces are presented by the radar in a form that may be utilized to locate the rain core of the thunderstorm.

The 10-centimeter ground radar has been examined for use in detecting regions of thunderstorm turbulence by means of data obtained from thunderstorm investigations conducted in Florida and Ohio. The data were analyzed for differences between the gust experience of airplanes operating within the indicated storm area and at distances of 2 to 5 miles from the indicated area of thunderstorm activity. The gust experience of airplanes operating within the 2- and 5-mile limits was assumed to be indicative of turbulence intensities in clear air near the thunderstorms.

Some results of this analysis are presented in figure 4. The ordinate is effective gust velocity and the abscissa is average miles flown to experience given effective gust velocities. The lower line represents the gust experience of airplanes operating in clear air near the storm. The upper line represents the gust experience of airplanes operating within the area giving a radar echo.

The gust velocities encountered in the indicated area of thunderstorm activity are in all cases greater than those encountered during equivalent distances of flight outside the storm. For example, an effective gust velocity of about 30 feet per second was encountered, on the average, once during every 100 miles of flight in areas giving a radar echo. A gust velocity of only about 20 feet per second was obtained however, for equal distances of flight in clear air near the storm. This represents a substantial difference in gust experience, and indicates that the ground radar set is of value as a supplement to pilot judgment in avoiding regions of intense thunderstorm turbulence.

The 10-centimeter ground radar lacks mobility and can cover only a limited area about the location of the radar set. The equipment also lacks the ability to define the altitude at which the turbulence exists. The instrument indicates the distance and the horizontal direction from the radar set to reflecting surfaces, which may be at altitudes of 5 to 20 thousand feet. Some implications of these characteristics of ground radar are shown in figure 3. Ground radar would indicate an area of thunderstorm activity similar to the ground projection of the rain core. An airplane flying above this ground projection of the indicated area of thunderstorm activity may actually be in clear air outside the storm.

Airborne radar is superior to ground radar in that its beam or signal does not intercept the entire storm. Airborne radar indicates only the horizontal extent of the storm in a layer about 2000 feet thick at the flight altitude. For storms such as this, airborne radar would detect the altitude differences in horizontal area of the rain core. The area of the rain core is presented therefore in a form that is particularly advantageous for turbulence detection. The relations between areas of thunderstorm turbulence and airborne-radar indications of regions of thunderstorm activity have been investigated for the standard 3-centimeter radar and a 3-centimeter airborne radar set modified to indicate areas of light and heavy rain.

Some results obtained from flights with the standard airborne radar are shown in figure 5. The data are presented on a mileage basis as before. The gust experience of the airplane is shown for flights within the region of clouds giving a radar echo, in the cloud but not in the region giving an echo, and in the clear air near the clouds. It may be noted that the results agree with those for ground radar and show that those areas of clouds giving a radar echo contain the more severe turbulence. The gust velocities are lower than those indicated in figure 4, however, inasmuch as the clouds investigated with airborne radar were large cumulus clouds but not necessarily thunderstorm clouds. It may also be noted that the large gust velocities are sometimes encountered in clouds not giving radar echoes. Some clouds or portions of clouds contain large gust velocities but have too small a water content to be detected by radar. This is especially true of small building cumulus clouds such as are represented by the greater portions of this data. Although the standard radar sets enable a significant reduction of gust experience, the instrumentation does not detect all regions of intense turbulence. It is also known that very little turbulence is encountered in some parts of the areas giving a radar echo.

If the flight must pass through a front or squall line, it is desirable to detect the smoothest possible flight path through the area. The standard airborne and ground radar sets are unable to detect the smooth and rough portions of the rain core. An attachment for indicating areas of light and heavy rain offers the most promising method for enabling airborne radar to perform this task. The device makes use of variations in the strength of the return signal or echo as it is usually called. Since the strength of the echo depends upon the number and size of water droplets in the cloud, the attachment may be utilized to block or erase the stronger signals received from areas of heavy rain.

An example of this type of presentation is shown in figure 6. The photograph shows the usual radar method of presenting the indicated area of the rain core. The dark area represents the area of no rain surrounding the cloud. The white portion of the slide represent the areas of light rain, and the circles are the range marks. The white dot in the very center represents the location of the airplane at the time of the photograph. The signal has been completely erased in this portion of the storm where the heavy rain is occurring.

The enlarged inner portion of figure 6 is presented in figure 7, with the airplane position indication removed. The circle is the 10-mile-range mark and within it is the enlarged presentation of the areas of no rain, light rain, and heavy rain. The interesting feature of this form of presentation is the variation of distances between areas

of no rain and heavy rain. In one portion of the storm, the contour indicating the beginning of light rain is very near the contour indicating the beginning of heavy rain. In other portions of the storm the distance between these same contours, the contour spacing as it is usually called, is several times as great.

Greater shearing stresses are generally associated with the regions of thunderstorms having a rapid rate of change from no rain to heavy rain. It would appear reasonable, therefore, to expect more intense turbulence in the region of narrow contour spacing than in the region of wide contour spacing. Available data have therefore been analyzed to determine if airborne radar with the contour attachments is of any assistance in locating the areas of light and heavy turbulence in regions of clouds giving a radar echo.

Some results obtained from this analysis are presented in figure 8. The ordinate is the average number of gusts greater than 10 feet per second encountered in each mile of flight for contours of a given distance. The abscissa is the distance between contours and the points represent the average number of gusts per mile for various contour spacings. The curve through the points indicates a rapid decrease in the number of gusts per mile as spacing between contours increases. These data would indicate that a substantial reduction of gust experience may be obtained by avoiding regions having a rapid rate of change of rain intensity. The data would indicate that the 3-centimeter airborne radar with the contour attachment is apparently of value as a supplement to pilot judgment in choosing the smoothest flight path through the front or squall line where the pilot has no opportunity to avoid the entire area of the rain core.

The data shown would indicate that areas of intense precipitation and turbulence are associated and that severe turbulence exists in regions containing a rapid change from no rain to heavy rain. These same areas are considered by some meteorologists to be most favorable for the formation of hail. Since hail is sometimes the cause of severe damage to airplanes, it is also desirable to avoid regions having a serious concentration of hail. The damage to one airplane as a result of flight through such an area amounted to about \$25,000. Over an extended period, the actual cost of hail damage plus the intangible costs resulting from having an airplane inactive might represent a sizable portion of the cost of installing airborne radar in the airplane.

In summary, the available information indicates that the location and intensity of turbulent regions may be estimated upon the basis of meteorological considerations. These estimates, especially of location, are rather crude and do not represent dependable methods for reducing

the gust experience of an airplane. Preliminary evaluations indicate that the greatest reduction of gust experience may be obtained through use of the 3-centimeter airborne radar with the attachment for indicating areas of light and heavy rain. This supplement to pilot judgment, although still in the preliminary stages of development, appears to be of value in reducing gust experience by detecting the smoothest flight path through fronts and squall lines.

REFERENCES

1. Gungorfer, I. I., and Press, H.: A Meteorological Measure of Maximum Gust Velocities in Clouds. NACA TN 1569, 1948.
2. Press, H., and Binckley, E. T.: A Preliminary Evaluation of the Use of Ground Radar for the Avoidance of Turbulent Clouds. NACA TN 1684, 1948.
3. Steiner, Roy: An Evaluation of Air-Borne Radar as a Means of Avoiding Atmospheric Turbulence. NACA RM L8101, 1948.
4. Ayer, R. W., White, F. C., and Armstrong, L. W.: The Development of an Airborne Radar Method of Avoiding Severe Turbulence and Heavy Precipitation in the Precipitation Areas of Thunderstorms and Line Squalls. Final Rep. on Task No. 1, Flight Eng. Branch, American Airlines System, Sept. 15, 1949. (BuAer Contract NOa(s)-9006.)

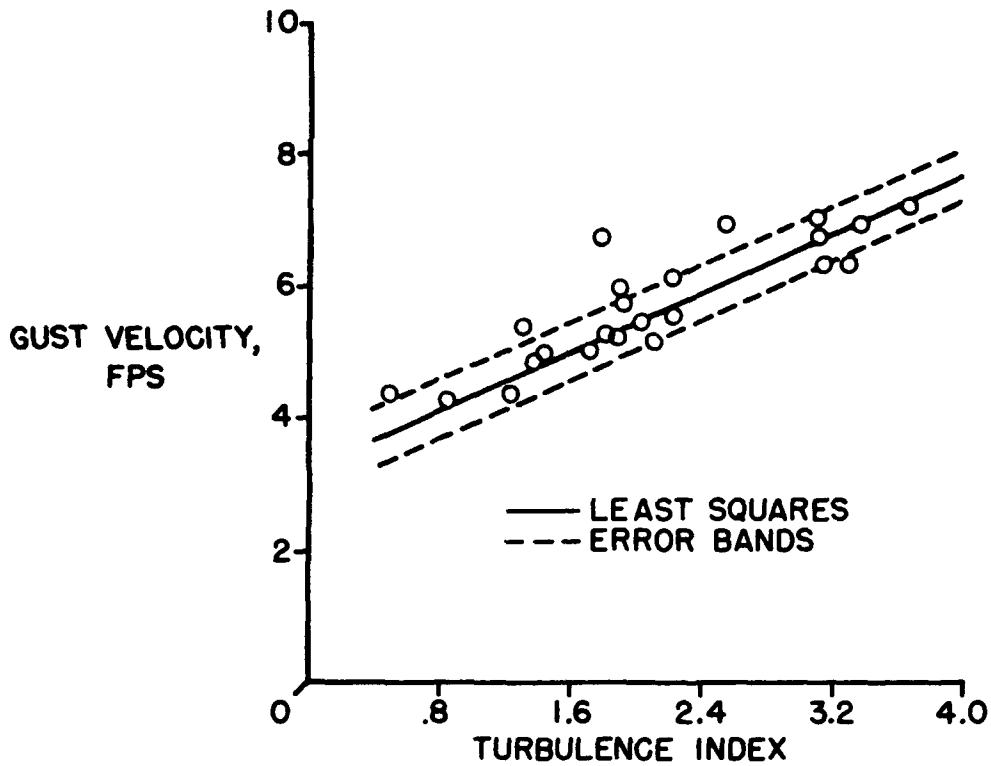

Figure 1. - Low altitude turbulence as a function of the product of wind shear and solar radiation.

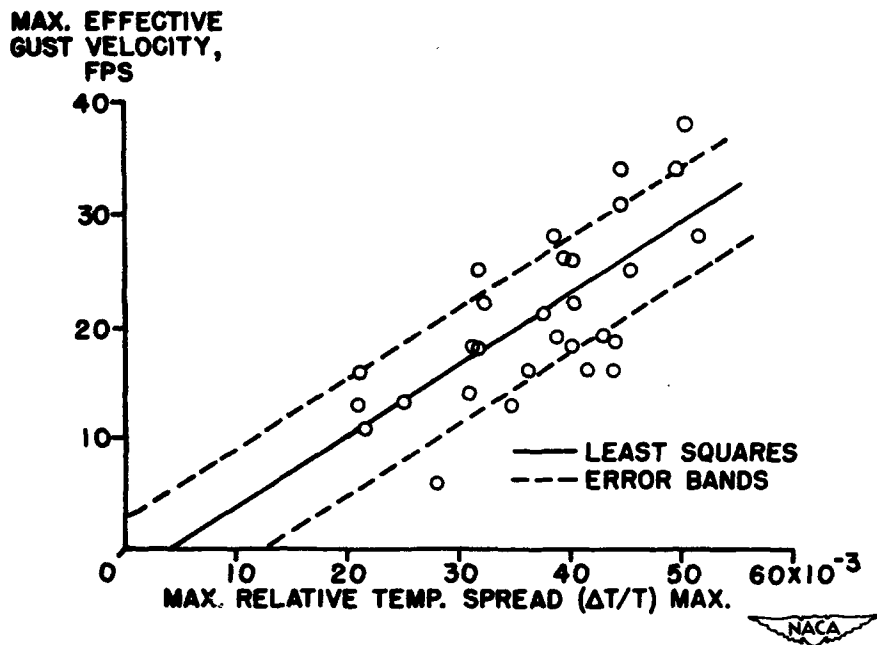

Figure 2. - The maximum effective gust velocity in thunderstorms as a function of relative temperature difference.



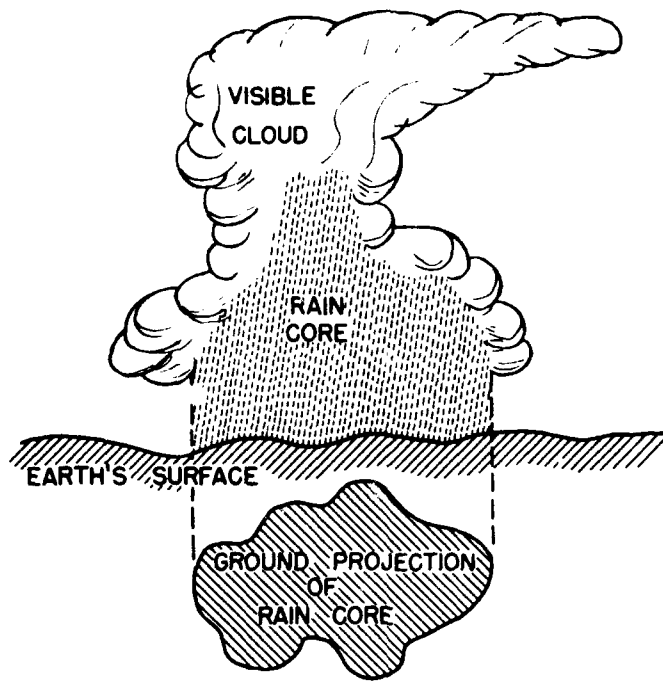

Figure 3. - The visible cloud and rain core of a large thunderstorm.

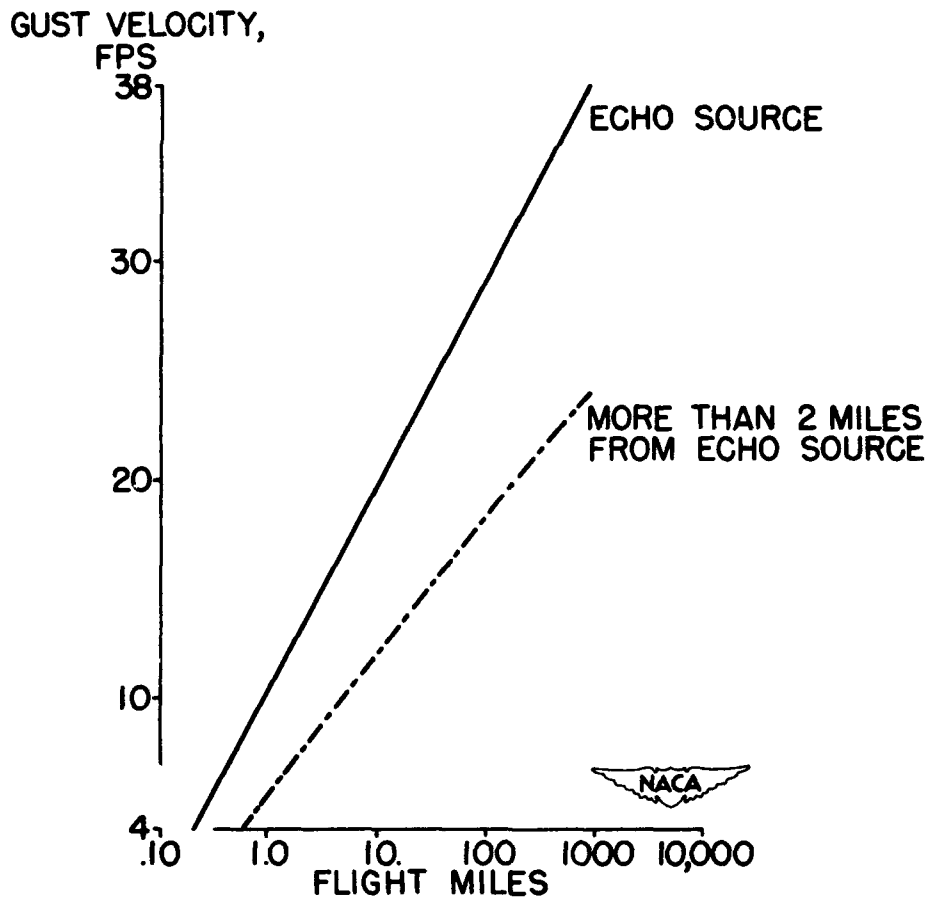

Figure 4. - Comparison of gust experience in and near ground radar indication of areas of thunderstorm activity.

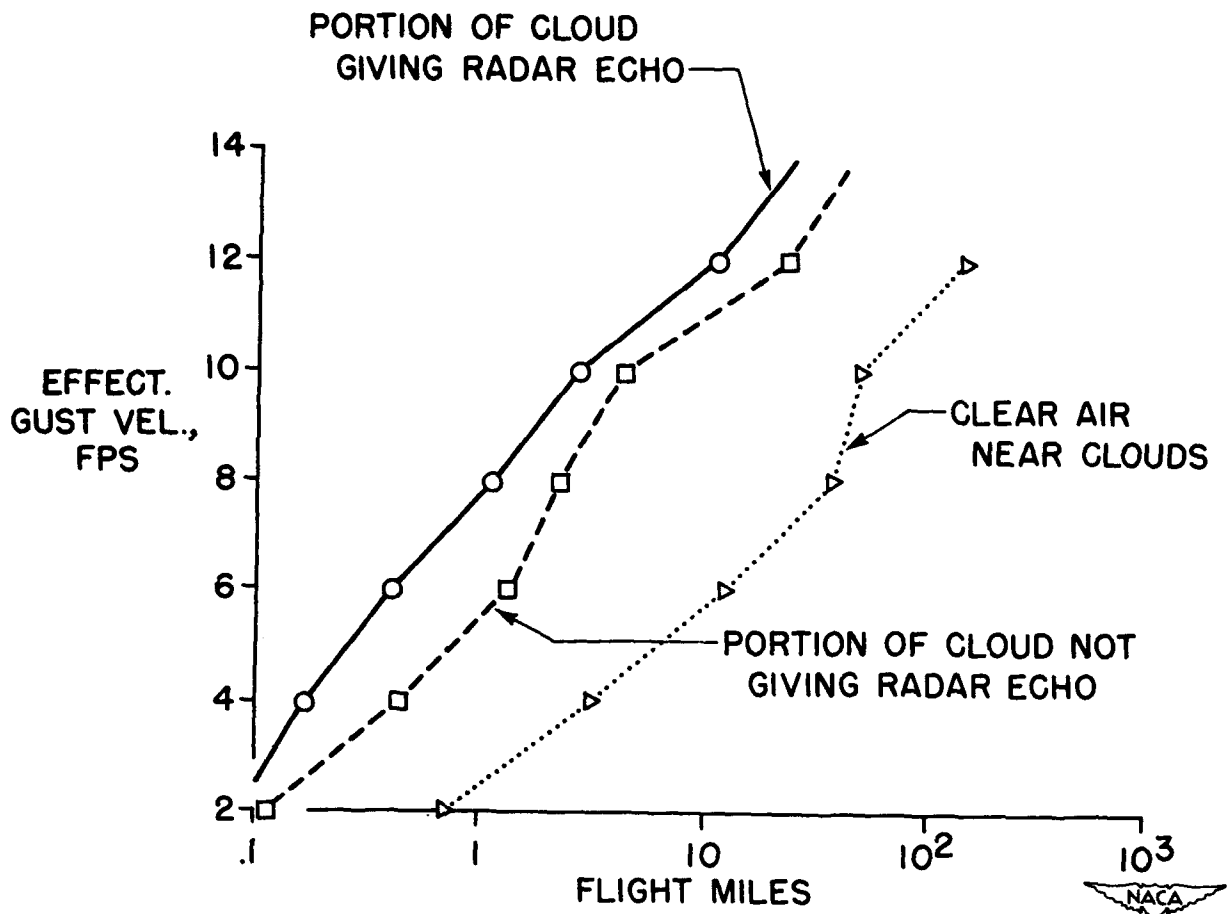

Figure 5. - Comparison of gust experience in and near airborne radar indications of areas of thunderstorm activity.

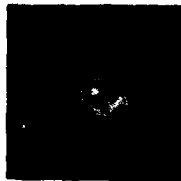

Figure 6. - Airborne contour radar method of presentation.

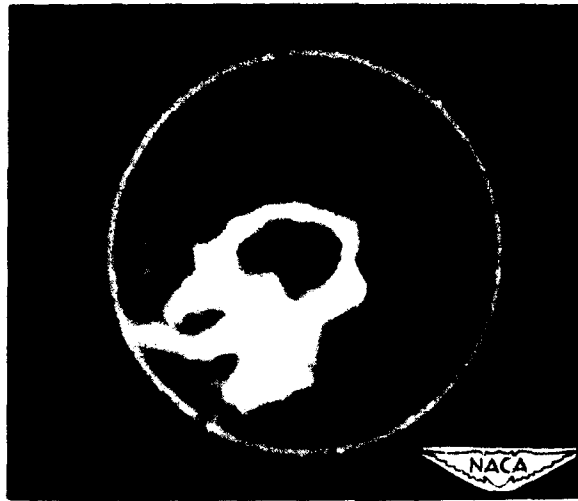

Figure 7. - Enlargement of the center portion of figure 6.

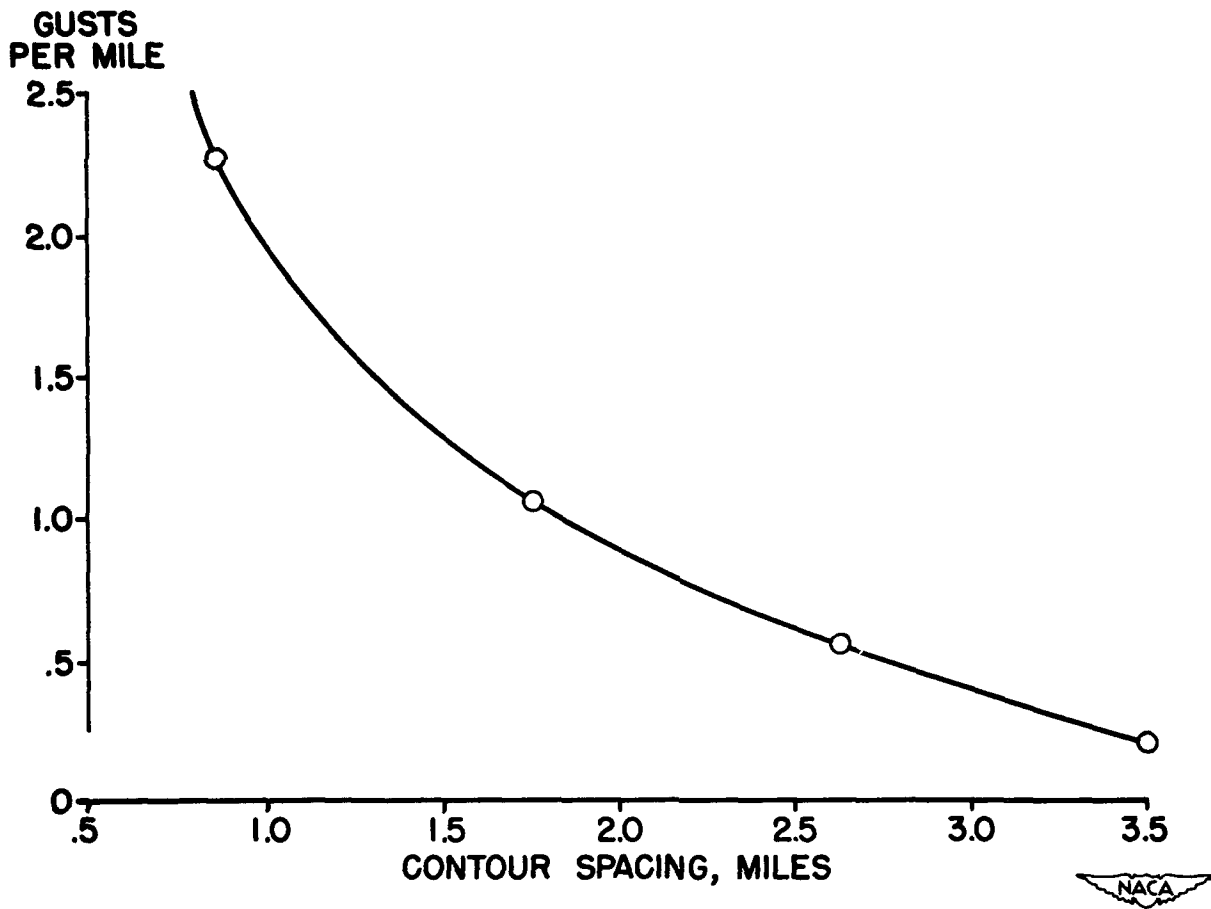

Figure 8. - Frequency of encountering large gust velocities as a function of contour spacing.

5. SOME ASPECTS OF GUST ALLEVIATION

By Harold B. Pierce

ATMOSPHERIC TURBULENCE AND ITS EFFECT ON AIRCRAFT OPERATION

5. SOME ASPECTS OF GUST ALLEVIATION

By Harold B. Pierce

Langley Aeronautical Laboratory

The effect of what flying through rough air does to an airplane and the people in it is familiar to most persons. Gust alleviation is ideally expected to eliminate the loads and stresses normally imposed on the airplane by the rough air and to make the passengers feel as though they were flying through calm air. Methods to fully accomplish these ideals for the modern transport airplane have not been developed. Although complete gust alleviation does not appear likely in the near future, a partial attainment of either object appears possible and would be of value.

In order to show what effects partial alleviation can have, a calculation was made for a typical present day large transport flying at 15,000 feet on a thousand mile flight which had 90 percent smooth air and 10 percent rough air. The results are shown in Figure 1 as the average number of times an acceleration increment of ± 1 g would be exceeded on this flight as a function of the indicated airspeed. The curves show the count for the airplane as is (0 alleviation) and the count when the acceleration from each gust is alleviated or reduced by 10, 20, and 40 percent. To give you an idea of how big a bump a 1 g acceleration increment represents, a minus 1 g increment just starts to lift a passenger from his seat. Thus, the number of accelerations or loads counted in this way might be of interest to the operator as a measure of meals spilled or of possible physical damage to the passenger if his seat belt were not fastened. For the condition selected, this airplane did not experience acceleration increments greater than 1 g until it flew through the rough air at about 225 miles an hour (Figure 1). But, as the speed was increased from 225 to 400 miles an hour, the number of acceleration increments greater than 1 g increased rapidly to 150, showing how much the roughness of the ride increases with speed.

Although the alleviation reduces the magnitude of the accelerations by the percentages shown, that is, 10, 20, and 40 percent, the effect on the number of accelerations exceeding 1 g is much greater. For instance, at 350 miles an hour, 40 percent alleviation reduces the count from 80 to 2 or nearly 98 percent. Another use of partial alleviation becomes apparent when consideration is given to its effect as the speed of the airplane is increased. If it is assumed that the roughness of ride in the unmodified airplane at 225 miles

an hour should not be exceeded at higher speeds, figure 1 shows that at 350 miles an hour about 40 percent alleviation of the acceleration would be required. It should be emphasized that these results are for an airplane with all its characteristics held constant, flying at different speeds, through the same gust environment. In all probability, the increases of forward speed considered here would, in the actual case, involve, among other things, operation at higher altitudes with a subsequent reduction in the number of gusts encountered. However, if partial alleviation can be obtained, it can have a pronounced effect on the apparent roughness encountered in bad weather. In addition, it should reduce the loads encountered by the percentage of alleviation used and not only provide a margin of safety for the large loads but also, by reducing the over-all level of the loads, it should increase the fatigue life of the airplane.

This paper is concerned primarily with the alleviation of the loads and the stresses caused by flying through rough air. It is often considered that an alleviation of the accelerations caused by gusts is synonymous with the reduction of all the loads and stresses. This concept is not always true, because some methods of alleviating the acceleration reduce certain of the stresses but increase other stresses. Therefore, although the amount of alleviation of acceleration is a good preliminary measure of the alleviation of load, further analysis is always required to be sure that the method used to alleviate the acceleration has actually reduced the stresses.

The majority of the loads caused by flying through rough air occur during rapid motions of the airplanes that are characterized by quickly applied accelerations or bumps and small but violent pitching and rolling motions. Flight tests have shown that the lift changes causing these motions can occur in as little as a tenth of a second and at a frequency of from four or five times a second for a moderate speed transport to 10 or 11 per second for a high speed jet fighter. Thus, a gust alleviator to reduce the loads must be able to detect the gusts and act very quickly to counteract the lift changes.

To simplify the discussion, the methods of alleviation considered here have been reduced into three broad categories. These categories are: alleviation by use of a detector and servo system, alleviation by a structural deformation, and alleviation by reduced lifting ability.

Figure 2 shows several different methods of obtaining alleviation using a detector-servo combination to operate a lift reducing system. Because it is so often proposed as a means of alleviating gust loads, the autopilot is considered first. The autopilot attempts to maintain a constant pitch attitude of the airplane by measuring pitch angle changes or pitching velocity and then correcting for the attitude change of the airplane by moving the elevator. Normally a change in the angle

of attack of an airplane is the same as a change in pitch attitude, but, in a gust, the angle of attack change is primarily a change in the direction of the relative wind and not a change in the attitude of the airplane. Thus, if the gust pushes the airplane up or down without changing its attitude, the autopilot can do nothing about reducing the load. In addition, with the elevator being used to correct any attitude changes, the whole airplane must be rotated to change the angle of attack of the wing. Since the gusts causing most of the loads are quickly applied and occur in rapid succession, it is unlikely that the elevator can rotate the airplane back and forth fast enough to keep up with the load application. When tests were made, no difference could be observed in the loads and motions in rough air whether a human pilot or an older type autopilot sensitive to pitch angle was controlling the airplane. No quantitative data have been obtained with the newer rate types of autopilot.

A more direct method of changing the effective angle of attack of the wing than by rotating the whole airplane is to use a wing flap that can move up to counteract an up gust or down for a down gust. Since a wing flap weighs less than the whole airplane, it can be rotated much more quickly and should be able to keep up with the rapid angle of attack changes of the gusts. The remaining four illustrations of detector-servo systems shown in Figure 2 make use of the flap to reduce the lift on the wing. The first flap system shown measures the acceleration due to gusts and attempts to maintain the airplane at 1 g by moving the flap. The second system directly measures the angle of attack change by a vane ahead of the wing and attempts to cancel its effect by moving the flap. Since flap deflection generally produces a tendency for the airplane to pitch violently, the next system indicates the addition of interconnected elevator movement to counteract the pitching moment caused by the flap. This elevator interconnection, of course, would not be restricted only to this particular flap system. Calculations have shown that each of these three flap systems is a promising gust load alleviator. Because of their complexity, however, the model tests have not been made. The last system shown which attempts to maintain constant altitude within very fine limits by moving a flap could be tested in the NACA gust tunnel at the Langley Aeronautical Laboratory. The tests were made to check our ability to predict gust alleviation with systems using flaps.

The results of this investigation are shown in Figure 3 as the acceleration alleviation as a function of the distance to peak acceleration or load. The curve represents the calculated results and the circled points are test results obtained in two different gusts, one a sharp-edged gust and one a gust whose horizontal distance to peak velocity was about 8 chords. The altitude or vertical displacement operated flap system showed little alleviation when the load was quickly applied, for the airplane model did not have time to move vertically before peak load passed. However, as the time or distance to maximum acceleration

became greater, the model had more time to move vertically with the gust and the alleviation was greater. The other flap systems mentioned which detect acceleration or angle of attack should provide more alleviation in the shorter gusts. The agreement obtained between experiment and calculation indicates that the alleviation obtained with a flap system can be predicted for the single gust.

Although flaps can reduce the acceleration, vertical load and bending moment on the wing, examination shows that large moments tending to twist the wing are developed when they are deflected. Figure 4 shows an example of the torque loads developed by the deflection of gust alleviating flaps considered for application to a particular airplane. The results are shown as the applied torque as a function of flap deflection in percent of the torque present with no flap deflection. The circled points on the curve show the flap deflections and applied torques for different amounts of acceleration alleviation. It can be seen that 20 percent alleviation (5 degrees of flap deflection) increases the torque over 100 percent. If the airplane were already strong enough to withstand this increase in torque load, advantage could be taken of the alleviation of the vertical load and the bending moments. In this case, however, not even 5 percent alleviation could be obtained without adding material to the wing and a complete redesign would be necessary to achieve any benefits in weight saving if 20 percent alleviation were desired.

Considering detector-servo systems as a whole, the alleviation to be obtained may be predicted quite well for a single gust. The vertical loads, acceleration, bending moments and torques are all amenable to calculation. Unfortunately, the behavior of airplanes in sequences of gusts extending beyond about 20 or 30 chord lengths cannot be predicted satisfactorily at present. In addition, detector-servo systems are potential oscillators and thus may be susceptible to possible flutter or divergence reactions. Little work has been done to handle these problems.

The term, aeroelastic effects, is used to describe the structural deformations of an airplane wing in flight. In some cases the structural deformations are favorable and in others unfavorable. Gust alleviation by structural deformation takes advantage of favorable aeroelastic effects. An illustration of an aeroelastic effect from which gust alleviation is obtained is a sweptback wing. Since the center of air load on the wing is outboard on the wing and behind the wing root, when the wing is pushed up as though an up gust were encountered, the wing tip twists down and reduces the angle of attack (Figure 5). The result of this downward twist in an up gust is an alleviation of the loads and moments on the wing. Tests were made in the gust tunnel on a model having a sweptback wing with a stiffness representative of the wings of large transport airplanes. The experimental result agreed with the

calculated result of 20 percent gust alleviation. However, since there is more reduction in angle of attack at the tip than near the wing root, when the wing bends the center of lift on the wing shifts inboard on the wing and forward. In the model tests this effect caused a nose up pitching motion that reduced the alleviation from 20 percent to about 8 percent.

Another system using favorable structural deformation has been checked experimentally in the gust tunnel. It was an especially designed straight wing which twisted favorably when air loads were applied. Again, it was found that the reduction in acceleration was predicted with good accuracy. A wing of this type would be subject to aileron reversal effects, however, if the conventional aileron were used to provide control.

There probably would be a considerable amount of difficulty involved in designing an actual wing structure to deform in a predetermined manner to provide gust alleviation. There is one big advantage to using structural deformation to alleviate the gust load, however, and that is, that once designed for and incorporated, it is a property of the airplane itself and is not dependent on the operation of detectors and servos to achieve the desired alleviation.

In contrast to the detector-servo and the structural deformation categories of gust-alleviation systems which move flaps or twist the wing to reduce the load, the third category, reduced lifting ability, reduces the load by a change in size or shape of the wing. Figure 6 shows two possible ways of reducing the lifting ability of a wing. On the left is shown the effect of a reduction of aspect ratio, and on the right is shown the effect of sweep. The area of all the wings shown is the same. These curves of lift versus angle of attack are representative of what would be obtained in an ordinary test in a wind tunnel. The reduction in aspect ratio, in this case, from 6 to 1.44, reduced the lift for a given angle of attack change by 46 percent and sweeping the wing by 45 degrees, as in this case reduced the lift about 30 percent. Since the wing was swept by rotating the wing panels, the aspect ratio changed from 6 for the straight wing, to 3 for the swept wing, and a major portion of the lift reduction is probably due to this change in aspect ratio. All of the wings shown in Figure 6 have been investigated in the gust tunnel and it was found that the alleviations obtained could be predicted satisfactorily and corresponded roughly to the reduction in lift shown in the figure. Of course, these large values of alleviation were obtained under ideal test conditions where only the wing planform shape was changed. In actual practice, the wing area might have to be increased to obtain the desired high lifts necessary for reasonable landing speeds. An increase in area would also proportionately increase the loads in gusts with a consequent reduction in the amount of alleviation to be obtained.

Another method of reducing the lifting ability that is sometimes considered is a spoiler that can be left extended while flying through rough air. Tests in the gust tunnel indicated, however, that the response of the spoiler to the transient angle of attack change of a gust was not fast enough to provide much alleviation.

The status of knowledge on gust load alleviation can be summed up as follows: The alleviation to be obtained in a single gust by use of almost any method or device can be predicted to a fair degree of accuracy and the results of some model tests are available as confirmation. At present, there is not sufficient knowledge to predict the response in a succession of gusts. As far as is known, there are no quantitative data available from tests of gust alleviation devices on a full-scale airplane.

BIBLIOGRAPHY

1. Rhode, Richard V., and Donely, Philip: Frequency of Occurrence of Atmospheric Gusts and of Related Loads on Airplane Structures. NACA ARR L4I21, 1944.
2. Donely, Philip, and Shufflebarger, C. C.: Tests of a Gust-Alleviating Flap in the Gust Tunnel. NACA TN 745, 1940.
3. Reisert, Thomas D.: Gust-Tunnel Investigation of a Flexible-Wing Model with Semichord Line Swept Back 45° . NACA TN 1959, 1949.
4. Shufflebarger, C. C.: Tests of a Gust-Alleviating Wing in the Gust Tunnel. NACA TN 802, 1941.
5. Pierce, Harold B.: Test of a 45° Sweptback-Wing Model in the Langley Gust Tunnel. NACA TN 1528, 1948.
6. Mickleboro, Harry C.: Evaluation of a Fixed Spoiler as a Gust Alleviator. NACA TN 1753, 1948.

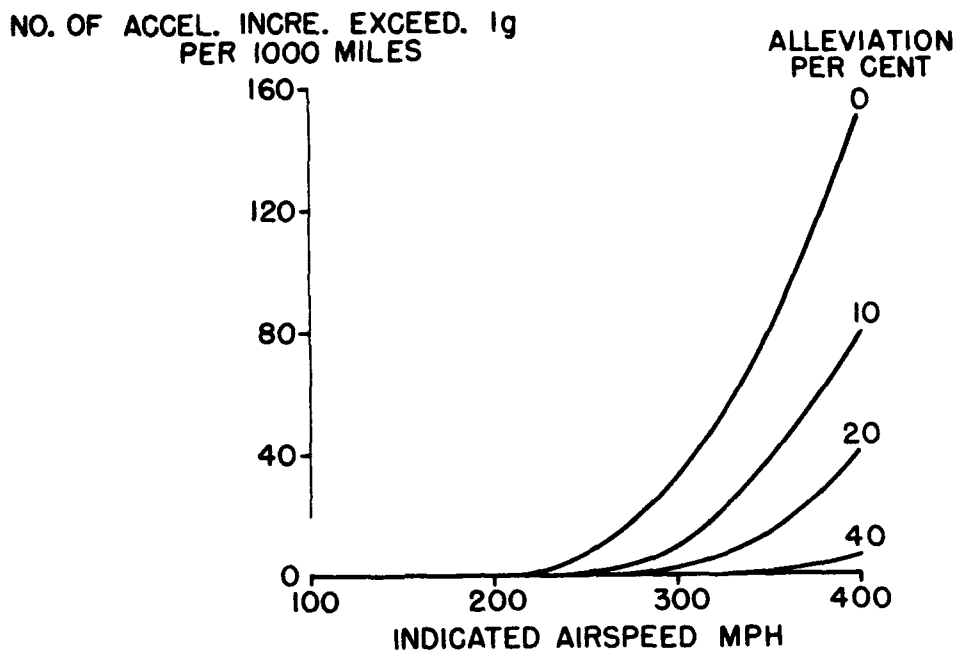

Figure 1. - Effect of partial alleviation on the number of acceleration increments greater than 1 g.

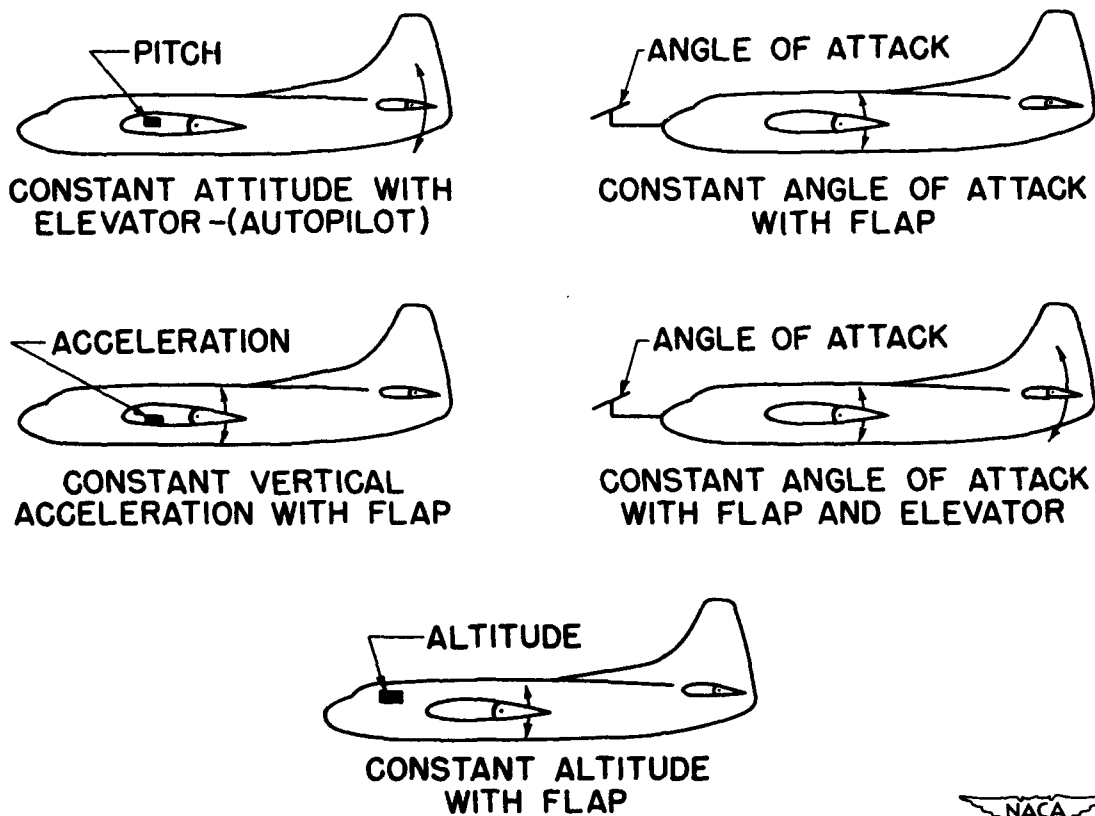

Figure 2. - Possible detector-servo systems for reducing gust loads.

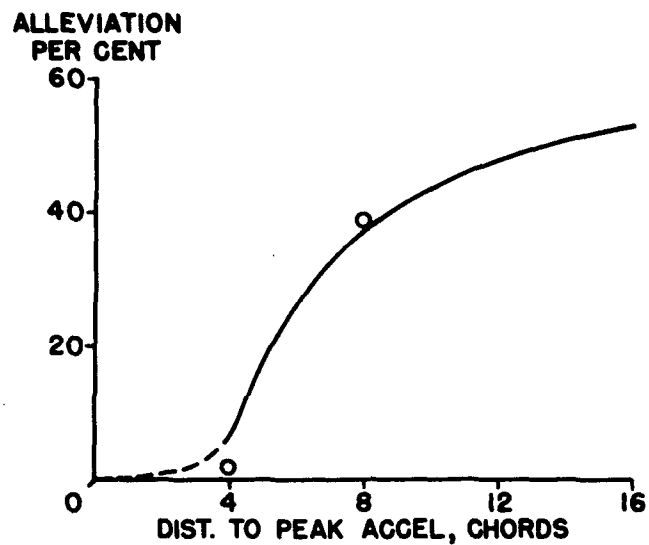

Figure 3. - Alleviation obtained with a dectector-servo system which attempts to maintain constant altitude within very small limits.

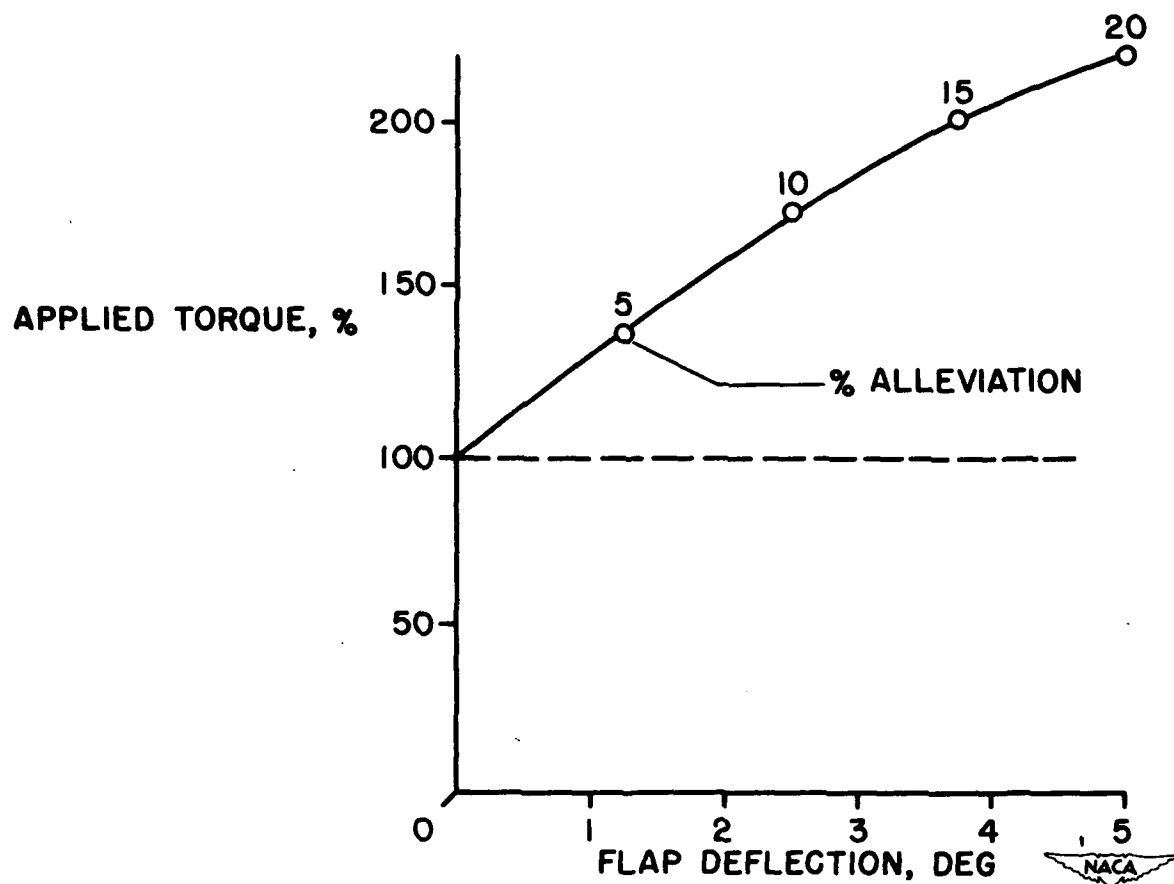

Figure 4. - Torque load caused by deflecting flap to obtain gust alleviation.



Figure 5. - Demonstration of aeroelastic effect favorable for gust alleviation.

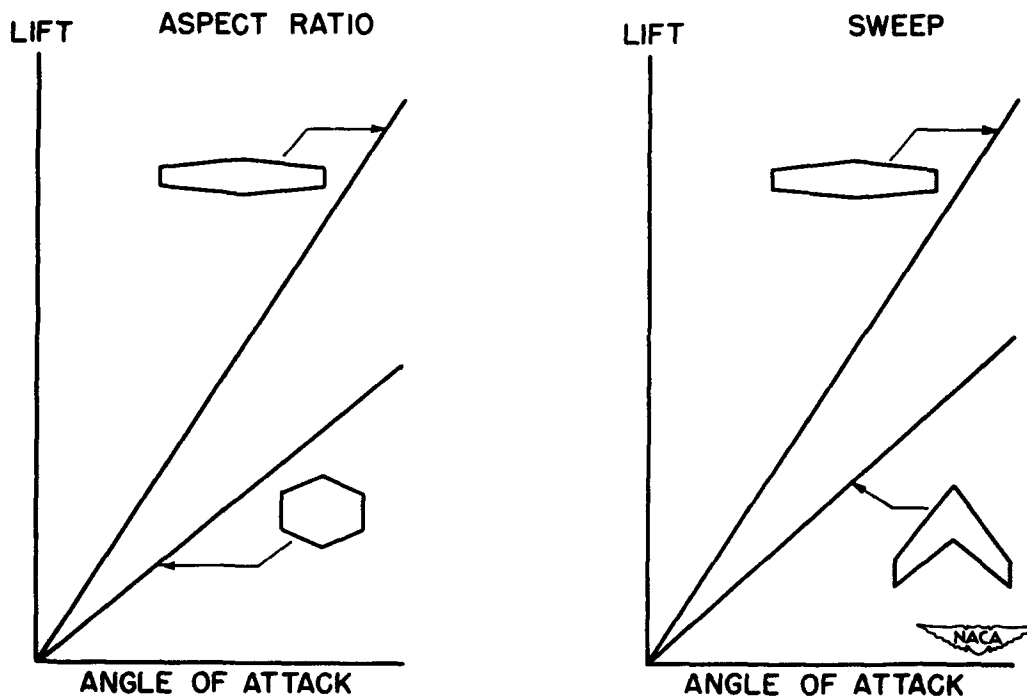

Figure 6. - Two means to obtain gust alleviation by reducing the lifting ability of a wing of given size.

6. ANALYSIS OF MEANS TO INCREASE THE SMOOTHNESS OF

FLIGHT THROUGH ROUGH AIR

By William H. Phillips

ATMOSPHERIC TURBULENCE AND ITS EFFECT ON AIRCRAFT OPERATION

6. ANALYSIS OF MEANS TO INCREASE THE SMOOTHNESS

OF FLIGHT THROUGH ROUGH AIR

By William H. Phillips

Langley Aeronautical Laboratory

This paper is based on a theoretical study of means to improve passenger comfort by increasing the smoothness of flight through rough air (reference 1). The paper is intended simply to give an indication of the types of device that would have to be incorporated in an airplane in order to provide smooth flight through rough air. Many practical problems in connection with the actual design and operation of such devices require further study before it can be determined whether the attainment of relatively smooth flight in rough air would be possible in practice.

Records of the motions of an airplane flying in rough air indicate that normal accelerations are relatively large, whereas lateral accelerations and changes in orientation are relatively small. Reductions in normal acceleration would therefore appear to be the most promising method of improving passenger comfort. In this paper the tendency of airplane motion to cause airsickness will be used as a criterion of passenger comfort. Some research was conducted at Wesleyan University in Connecticut to determine the relative importance of oscillations of various frequencies in producing airsickness (reference 2). In these tests a large group of men was subjected to vertical oscillations in a device similar to an elevator. Some of the results obtained in these tests are shown in figure 1. This figure shows the percentage of men who became sick within an interval of 20 minutes when they were subjected to oscillations of various frequencies. These data show that oscillations with a frequency of about $1/4$ cycle per second caused the most sickness, and that oscillations with the highest frequency tested, about $1/2$ cycle per second, caused relatively little sickness. It is unfortunate that the data do not extend to still higher frequencies, of the order of 1 or 2 cycles per second, inasmuch as many of the oscillations produced by rough air are in this higher frequency range. Nevertheless, these data appear to indicate that oscillations of relatively low frequency, or long period, are more likely to cause airsickness than oscillations of high frequency, or short period. In the design of a device to improve passenger comfort, therefore, it may not be

necessary to emphasize the reduction of response to gusts of very high frequency.

Two methods of acceleration alleviation will be considered from the standpoint of improving passenger comfort. One of these methods is pitching the whole airplane by means of the elevators to maintain a constant angle of attack during passage through gusts. The other is the operation of flaps on the wing by means of an automatic control system to offset the lift increments caused by gusts.

In calculations of the response to gusts, the airplane was assumed to fly through sinusoidal gusts of various wave lengths. Theoretically, any actual gusts could be resolved into sinusoidal components of this type and the resulting acceleration of the airplane could be computed by adding these effects of the sinusoidal gusts separately.

For comparison with later calculations that show the effect of devices intended to reduce the accelerations caused by gusts, the response of a typical transport airplane to gusts is shown in figure 2. This figure shows the normal acceleration and pitching velocity of a conventional transport airplane flying at a speed of 200 miles per hour encountering vertical gusts of various wave lengths. The amplitude of the gusts was taken as 5.1 feet per second, a value which produces an angle-of-attack change of 1.0 degree at 200 miles per hour. The accelerations caused by gusts of any other amplitude would, of course, vary in proportion to the amplitude. The figure indicates that for gust frequencies greater than 1 cycle per second the airplane experiences accelerations approaching a constant magnitude equal to that which would result from the lift imposed on the wing by an angle of attack equal to that resulting from the gust. At lower frequencies the acceleration decreases as a result of vertical motions of the airplane. The pitching velocity resulting from the gusts is low.

In order to study the possibilities of different systems of acceleration alleviation it is helpful to consider the control motions that would be required theoretically to produce zero acceleration of the center of gravity during flight through gusts. Elimination of the vertical accelerations does not necessarily avoid pitching of the airplane. Therefore pitching motions resulting with the different methods of control are also of interest. The elevator motion required to produce zero acceleration of the center of gravity in flight through gusts of various frequencies and the resulting pitching velocities are shown in figure 3. The elevator motion required increases almost linearly with frequency and reaches very large values at high frequencies. In addition it is found that the phase angle of elevator motion, not shown in the figure, must anticipate the angle-of-attack variation due to the gusts by large amounts. Such large phase leads are difficult to obtain in practice and indicate the reason for the inability of a human pilot to successfully counteract the effects of gusts. The pitching velocities shown in this figure also reach very high values. These high values of pitching velocity result from the fact that with elevator control it is necessary to rotate the

whole airplane to maintain a constant angle of attack during passage through the gusts. These large pitching velocities are undesirable because the accompanying pitching accelerations cause changes in vertical acceleration at points some distance from the center of gravity. For example, in this case the amplitude of vertical acceleration at a point two chord lengths from the center of gravity would be greater than that of the basic airplane with no acceleration alleviator at frequencies greater than two cycles per second. The use of elevator control therefore does not appear very promising as a means for producing smooth flight. There is a possibility, however, that the use of elevator control might have a beneficial effect in offsetting the low-frequency components of the oscillation which were shown previously to be primarily responsible for airsickness.

It might be thought that operation of the flaps to offset the lift increment caused by gusts would overcome these objections because the flaps can produce lift increments without the necessity of rotating the entire airplane. The flap motion required to produce zero acceleration of the center of gravity and the resulting pitching velocity are shown in figure 4. For these calculations it was assumed that the landing flaps were used as the acceleration alleviating device. These results show that the pitching motions produced by the use of the flaps are even larger than those produced by the elevator. These large pitching motions result mainly from the action of the downwash from the flaps on the tail. This downwash acts in the same direction as the gusts and therefore produces large pitching motions of the airplane. Furthermore, in certain frequency ranges the phase relationship of these pitching motions is such that the angle-of-attack change of the airplane adds to that of the gusts and as a result still more flap deflection is required to offset the acceleration increments. These results indicate that the use of conventional trailing-edge flaps for acceleration alleviation is not likely to prove successful.

An understanding of the flap characteristics required to offset the accelerations caused by gusts may be obtained by considering the sequence of events that occurs when the airplane penetrates a gust. The airplane is assumed to fly into a region in which a vertical gust velocity exists. When the wing penetrates the gust the flaps must move up to produce lift in the opposite direction. In order to avoid undesirable pitching motions of the airplane, however, the moment about the wing aerodynamic center caused by the flap deflection must be zero. Then when the tail penetrates to the region of the gust the downwash from the flaps should be just equal and opposite to the gust velocity so that no additional moments will be applied to the airplane by the tail. Such characteristics are not obtainable with ordinary flap designs. The provision of zero pitching moment about the wing aerodynamic center might be obtained by linking the elevator, or a portion of the elevator, to deflect in phase with the flap in order to offset the flap pitching moment. The desired downwash at the tail, which is opposite from that normally resulting from flap deflection, might be obtained by linking a portion of the flap near the fuselage to deflect in the opposite direction from the main part of the flaps further outboard.

In order to calculate the reduction of accelerations caused by automatic operation of the flaps during passage through gusts, the gust-sensing device required to operate the flaps must be considered. Studies have been made of the use of a vane mounted ahead of the airplane to detect gusts and of the use of an accelerometer to detect the airplane motion caused by gusts. The type of mechanism contemplated using the vane-type sensing device is shown in figure 5. The mechanism shown is just one of many possible arrangements that might be used. If the airplane encounters a gust, the vane deflects upward and operates a booster mechanism which causes the flaps to move upward. The linkage to the control stick shown in this figure requires further explanation. Normally, control of the airplane is accomplished by changing the angle of attack as a result of elevator deflection. Any device which offsets the lift increments due to change in angle of attack will prevent the pilot from maneuvering the airplane by means of the elevator. This difficulty may be overcome by linking the control stick to the flaps as well as to the elevator. When the pilot makes a pullup with such an arrangement, a rearward motion of the stick causes the flaps to move down, producing lift in the desired direction. Then, as the airplane responds, the flaps move back to their neutral position as a result of the angle-of-attack change produced by the vane.

The reduction of accelerations caused by rough air obtainable by use of such a device is shown in figure 6. The characteristics of the basic airplane are shown for comparison. It is seen that the acceleration may be reduced to about one-fifth of the values experienced by the basic airplane while pitching velocities remain low.

The stability and control characteristics of an airplane equipped with a device of this kind are shown by the response to an abrupt control movement. It is desired that following such a control movement the airplane should quickly reach a steady value of acceleration without overshooting or oscillating.

The response to control movement of an airplane equipped with the vane-type acceleration alleviator is shown in figure 7. The elevator is assumed to be suddenly deflected and held in the new position. The resulting motion of a typical transport airplane is indicated by the dashed line for comparison. When the airplane is equipped with the device discussed previously, a much more rapid response is obtained because of the production of lift immediately when the flaps are deflected. Nevertheless, the motion is very stable and shows no tendency to overshoot the final acceleration. The reduction of lag following a control deflection is thought to be an advantage, though actual flight tests would be required to determine pilots' opinion of this characteristic.

It is apparent that the incorporation of a device which provides smooth flight in rough air would require rather complicated additional mechanisms not provided at present though the external appearance of the airplane would be little changed. The possibility that interaction between the flap-operating mechanism and structural oscillations might

produce flutter requires further investigation. Nevertheless, the promising results obtained in the theoretical investigation indicate that experimental work to verify these results would be desirable.

REFERENCES

1. Phillips, W.H., and Kraft, C.C., Jr.: Theoretical Study of Means to Increase the Smoothness of Flight Through Rough Air. NACA TN (to be pub.).
2. Alexander, S.J., Cotzin, M., Hill, C.J., Jr., Ricciuti, E.A., and Wendt, G.R.: Wesleyan University Studies of Motion Sickness, Part I. The Effects of Variation of Time Intervals between Accelerations on Sickness Rates; Part II. A Second Approach to the Problem of the Effects of Variation of Time Intervals between Accelerations upon Sickness Rates. Jour. Psych., vol. 19, Jan. 1945, pp. 49-68. Part III. The Effects of Various Accelerations upon Sickness Rates; Part IV. The Effects of Waves Containing Two Acceleration Levels upon Sickness. Jour. Psych., vol. 20, July 1945, pp. 3-18.

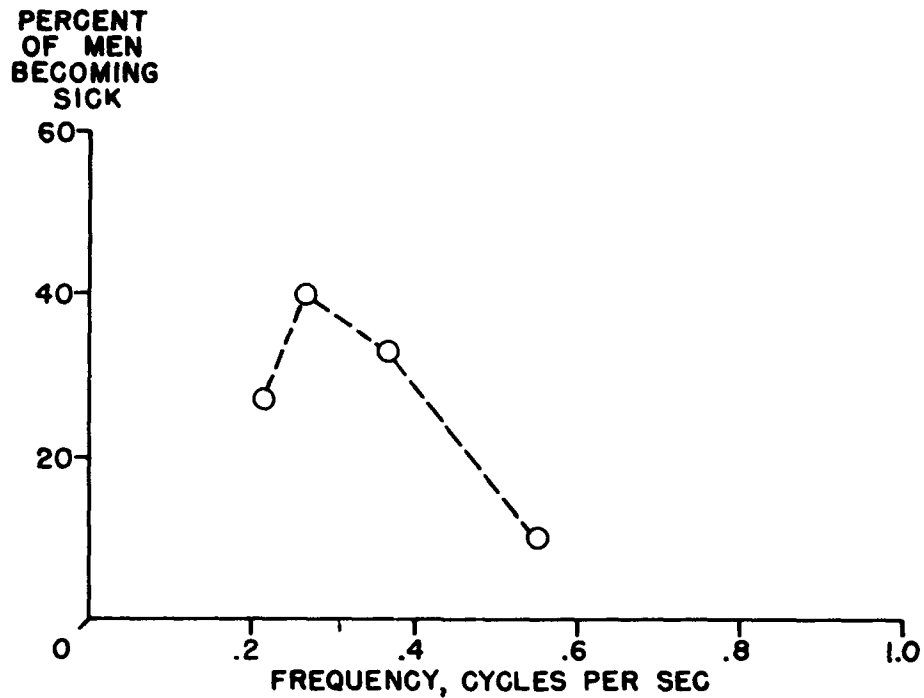

Figure 1. - Results of experiments on motion sickness.

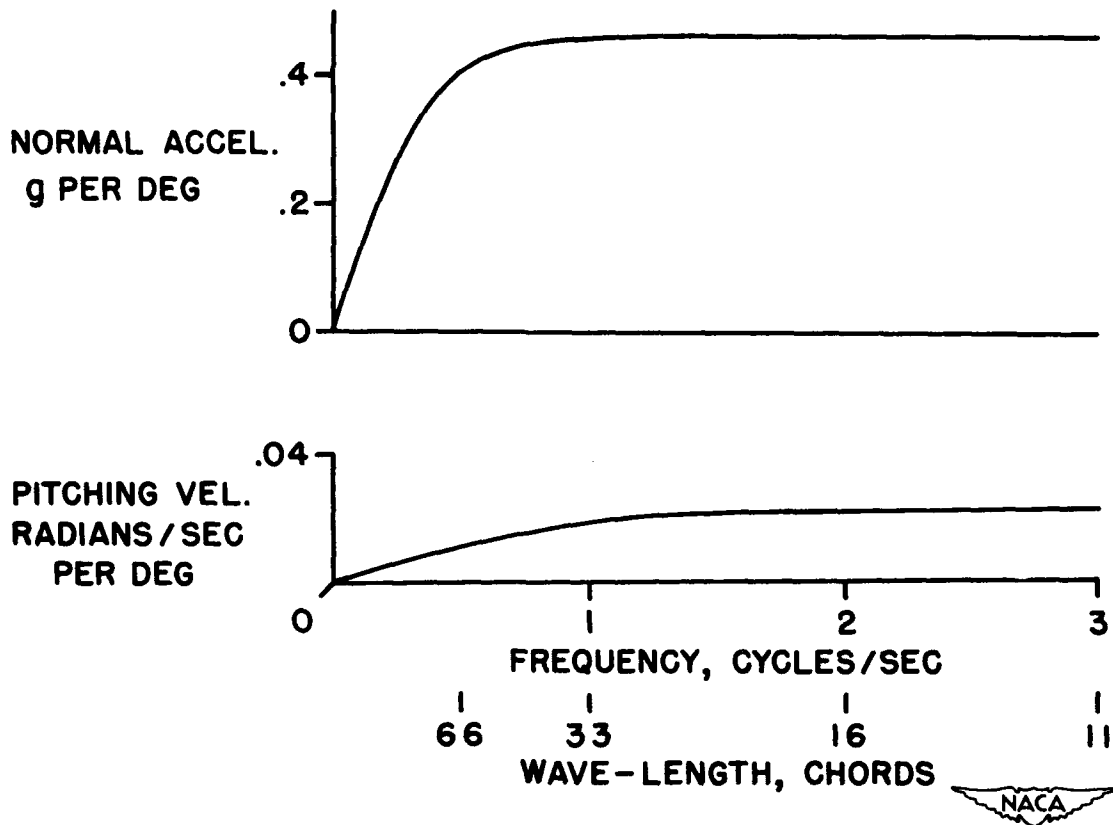

Figure 2. - Response of a typical transport airplane to sinusoidal gusts of various frequencies.

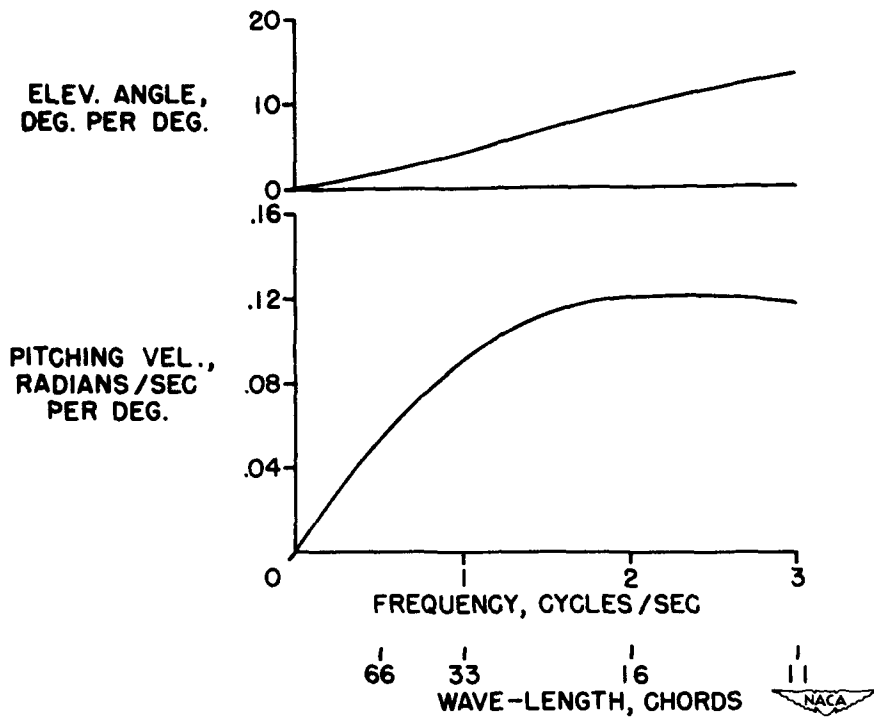

Figure 3. - Elevator motion required to produce zero acceleration of the center of gravity in flight through sinusoidal gusts of various frequencies, and the resulting pitching velocity.

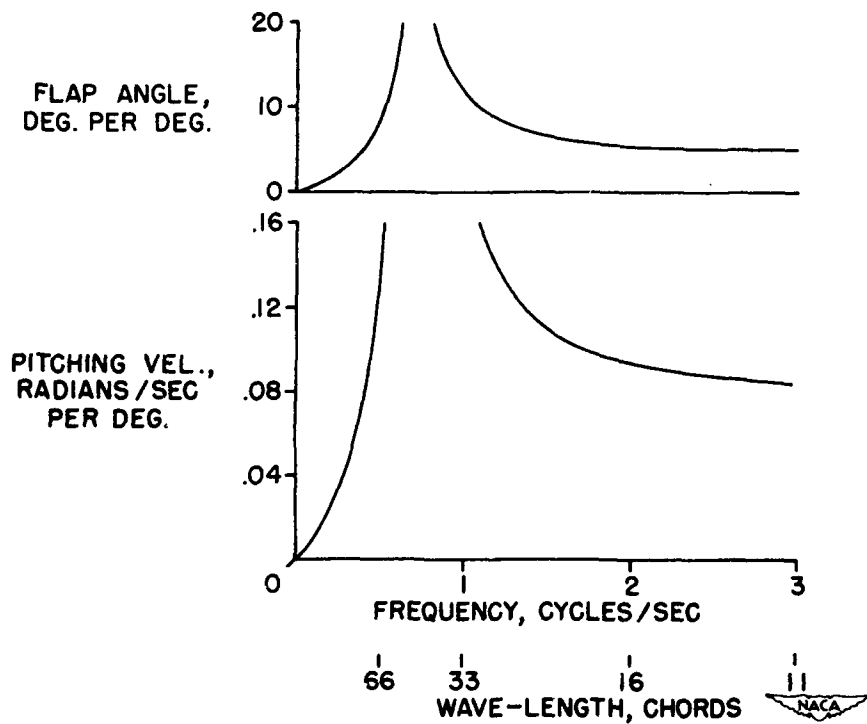

Figure 4. - Flap motion required to produce zero acceleration of the center of gravity in flight through sinusoidal gusts of various frequencies, and the resulting pitching velocity.

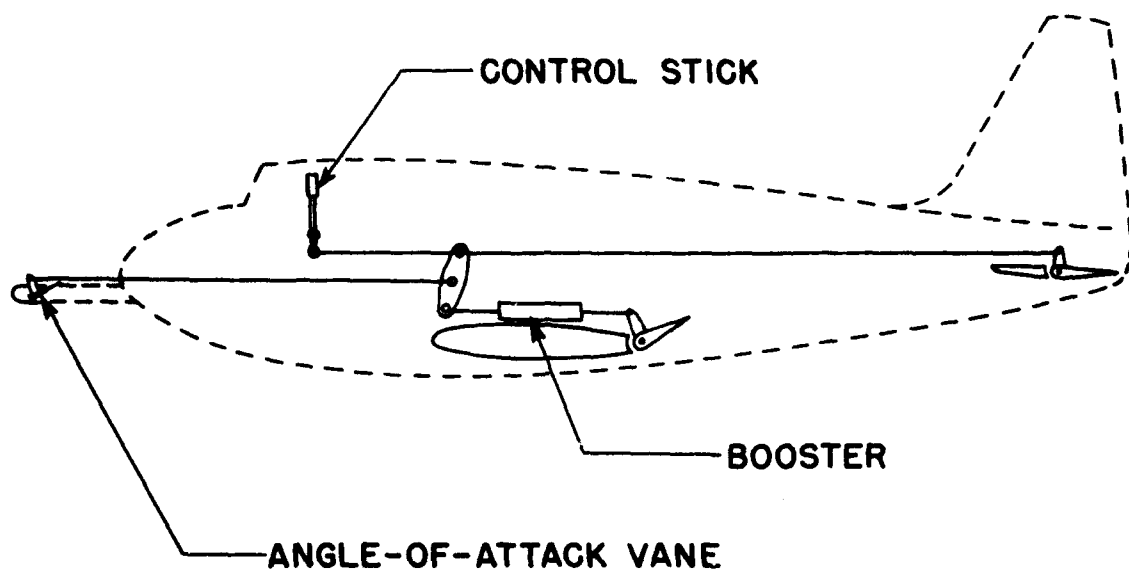

Figure 5. - Diagram of mechanism for vane-type acceleration alleviator.

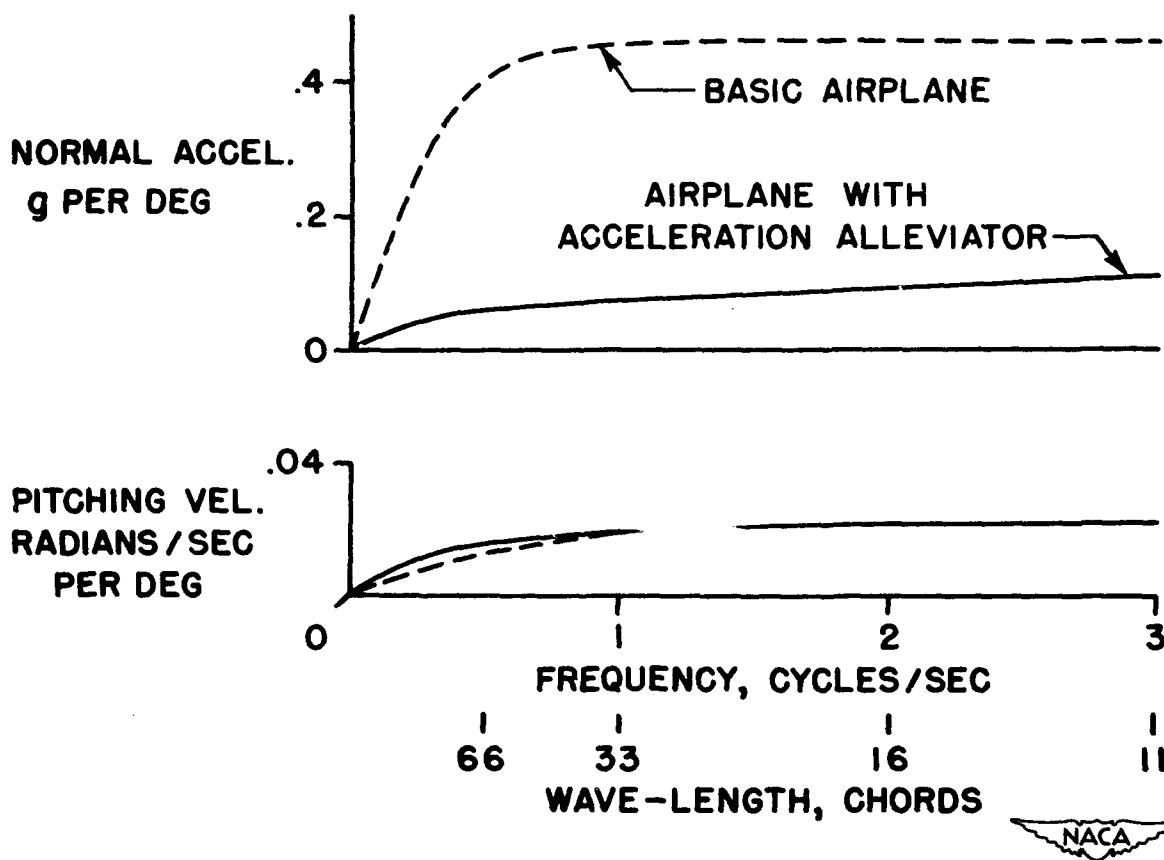

Figure 6. - Response of an airplane equipped with acceleration alleviator to sinusoidal gusts of various frequencies. Characteristics of basic airplane shown for comparison.



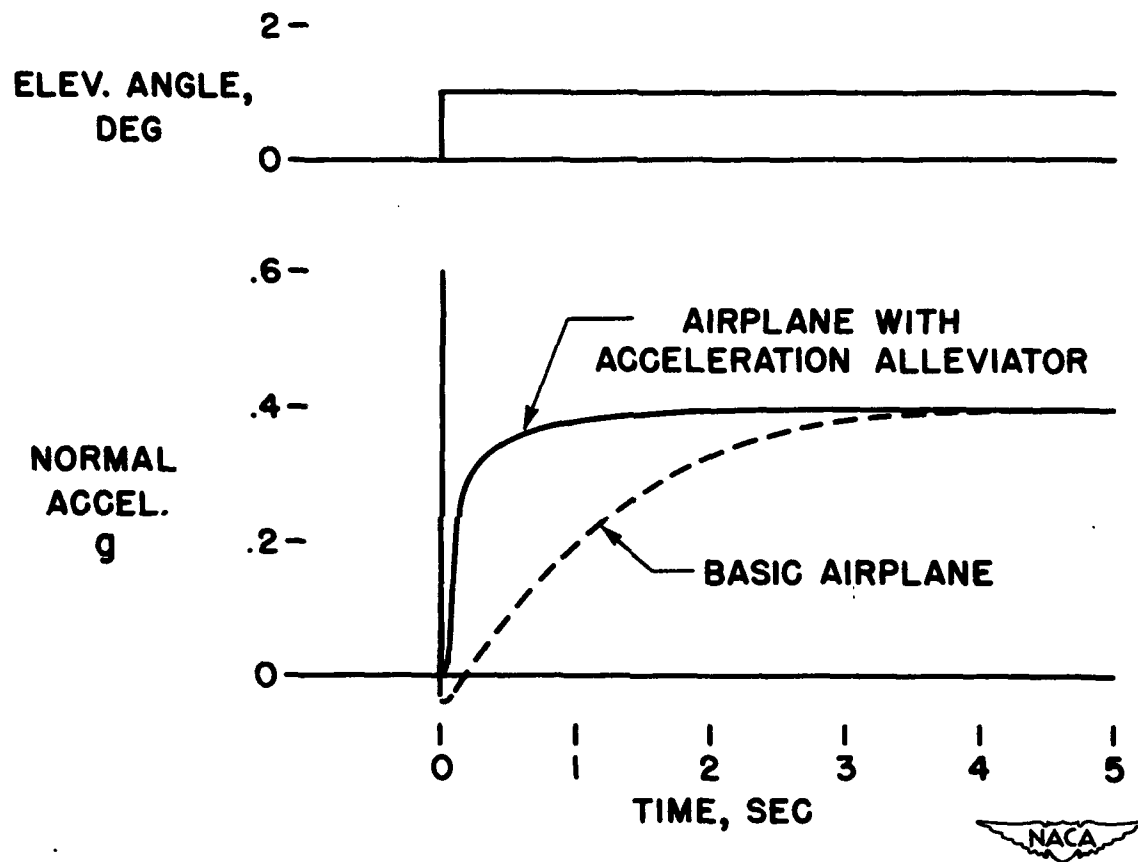

Figure 7. - Response of an airplane equipped with acceleration alleviator to an abrupt step motion of the elevator control.

RESTRICTED

SOME ASPECTS OF AIRCRAFT SAFETY - ICING, DITCHING AND FIRE

RESTRICTED

7. METEOROLOGICAL FACTORS IN THE DESIGN AND OPERATION OF
THERMAL ICE PROTECTION EQUIPMENT FOR HIGH-SPEED,
HIGH-ALTITUDE TRANSPORT AIRPLANES

By William Lewis, U. S. Weather Bureau

SOME ASPECTS OF AIRCRAFT SAFETY - ICING, DITCHING AND FIRE

7. METEOROLOGICAL FACTORS IN THE DESIGN AND OPERATION OF THERMAL
ICE PROTECTION EQUIPMENT FOR HIGH-SPEED,
HIGH-ALTITUDE TRANSPORT AIRPLANES

By William Lewis
U. S. Weather Bureau

The first successful thermal anti-icing systems were designed and built without the benefit of exact knowledge concerning the physical characteristics of the meteorological conditions in which they were expected to operate. The need for such knowledge was clearly recognized, however, and research was undertaken by the NACA to determine the probable range of values of each of the pertinent meteorological variables. During the past few years sufficient measurements have been made to allow approximate definition of the characteristics of the most severe conditions likely to be encountered in certain types of weather situations. At the same time, methods have been developed for the determination of heating requirements for various airplane components when the meteorological variables are specified.

With these developments has come the realization that it is not feasible to provide sufficient heat to prevent all ice formation in all possible icing conditions. It is necessary, therefore, for the designers to consider the probabilities that the airplane will encounter conditions of varying degrees of severity, and assume a calculated risk in basing the design on something less than the most severe icing conditions that might possibly occur.

Now the probability of encountering conditions of a given severity is obviously dependent upon the operating conditions, including such factors as geographical area and preferred flight altitude. It is also dependent upon the extent to which flight procedures are modified in order to avoid icing conditions or minimize their severity. This latter factor, in turn, depends upon the effectiveness of the anti-icing system. It is evident therefore, that the problems of design and operation are closely interrelated. The question of the extent to which it is practicable and desirable to reduce the design requirements because of reliance on the ability of the pilot to avoid the most severe and extensive icing conditions demands careful consideration. This matter is especially important for high-altitude airplanes.

The principal difficulty in a determination of the ice-protection requirements of high-altitude airplanes is due to the fact that nearly all of the data on icing conditions now available are from observations at altitudes below about 20,000 feet. It is necessary, therefore, to make an estimate of conditions to be expected at higher altitudes, which will serve as a tentative basis for anti-icing design until actual

measurements, taken if possible during normal operations, can provide more exact information.

The meteorological factors which are important in a consideration of icing conditions are liquid water content, cloud drop size, air temperature and air density. The severity of icing is obviously directly proportional to the liquid water content when all other factors are regarded as constant. Furthermore, for any particular value of liquid water content, the rate at which water is intercepted by a moving object, the area over which the impingement occurs, and the distribution of water collection over this area are dependent upon a combination of factors including the average drop size, the distribution of drop sizes about this average, the air speed, the altitude, and the size and shape of the object. The rate of water interception, or the rate of ice formation, per unit area normal to the flight path, is equal to the product of the liquid water content, the true airspeed and a factor called the collection efficiency, which is a function of drop size, airspeed, and the geometrical configuration of the airplane component. Since pilots customarily observe the thickness of ice in inches and values of liquid water content are usually expressed in grams per cubic meter, it may be noted that the thickness of ice in inches, which is collected during 13 miles of flight is approximately equal to the liquid water content in grams per cubic meter times the collection efficiency.

Unlike liquid water content and drop size, the effect of temperature on the severity of icing as experienced by an unheated airplane is quite different from its effect on the difficulty of ice prevention by means of heat. In terms of thermal ice prevention, the severity of icing increases continuously as the temperature is reduced. On an unheated surface, on the other hand, ice which forms at very low temperatures usually has a smooth and pointed form, and has a less unfavorable effect on the performance of the airplane than the rough and irregular shapes which form at only a few degrees below freezing.

In the case of high-speed airplanes, the effect of kinetic heating in maintaining the temperature of the airplane above the free-air temperature is quite important. Tests have shown that in air containing water drops, the amount of the kinetic temperature rise is about 90 percent of that which would be produced by bringing the air to rest by a saturated-adiabatic process. This effect is illustrated in Figure 1. In the construction of this figure, it was assumed that the freezing level was at 10,000 feet pressure altitude and the lapse rate of air containing liquid water drops was moist-adiabatic. Under these conditions the curve indicates the relation between true airspeed and the temperature and pressure-altitude at which the leading-edge surface would be at 32° F, which of course, is the critical condition for the onset of icing. It is seen that an airplane flying at 500 mph would

have to reach an altitude of 17,000 feet when the temperature is 6° F before icing would be experienced.

Nearly all of the data now available on liquid water content and drop size in icing conditions have been obtained using airplanes with a practical service ceiling of about 20,000 feet. Hence, any estimate of conditions likely to be encountered at higher altitudes must necessarily be based on extrapolations. Moreover, nearly all of the observations were made during winter and spring, while it is expected that the most severe and frequent icing conditions at higher altitudes may occur in summer. Under these circumstances, the best that can be done at present is to examine the data now available and proceed with caution to extrapolate to higher altitudes.

Nearly all flight measurements of cloud drop size have been made by means of the rotating cylinder method. This method yields what is called the "mean-effective diameter", which is believed to be approximately equal to the median of a volume distribution. When the mean-effective diameter is known, the rate of water interception can be calculated with reasonable accuracy. The maximum area of drop impingement, however, is determined by the size of the largest drops, and is therefore dependent also upon the distribution of drop diameters.

An examination of available data on mean-effective diameter, taken in various parts of the United States shows the existence of a significant variation with geographical location. Measurements made along the Pacific coast show larger values of drop diameter, both average and extreme, than are observed in other parts of the country. This effect is believed to be due to differences in the kind and number of condensation nuclei, the hypothesis being that air which comes from over the ocean contains a small concentration of large condensation nuclei, probably composed of sea salt. If this is true, a tendency to large drops would be expected generally over the sea and along coasts having prevailing on-shore flow.

Data from cumulus clouds in all areas and from layer clouds on the Pacific coast do not reveal any significant variation of mean-effective diameter with altitude. Observations in layer clouds in eastern U. S., however, definitely indicate an increase in drop size with increasing altitude. These results are shown in Figure 2. On this figure are shown smoothed distribution curves for observations of mean-effective diameter in layer clouds in eastern U. S. at altitudes above and below 10,000 feet. The ordinates represent the percentage of observations lying within a 2-micron range. It is noted that the observations from above 10,000 feet show a higher average diameter and a greater variability, with higher frequencies in the range from 14 to 30 microns.

The characteristics of these distribution curves may be described by means of certain statistical parameters as shown. These are the mode, or most frequent value, the median, a value such that half the observations are above and half below, and the fifth and ninety-fifth percentiles which mark the lowest and highest 5 percent of the observations. It is also noted that, although the higher-altitude observations have a greater median and mode the 95th percentile is nearly the same, indicating that there is little change with altitude in the probability of encountering very large drops.

Figure 3 (table) shows values of some statistical parameters for the distributions of observations of mean-effective diameter in cumulus clouds and layer clouds in the Pacific coast region and in eastern United States. It is seen from this table that median and modal values of drop diameter in layer clouds on the Pacific coast are not greatly different from the higher-altitude observations in the eastern U. S., but the range is much greater. The 95th and 99th percentile values are 44 and 67 microns for the Pacific coast as compared with 23 and 29 for higher altitude layer clouds in the east. Cumulus clouds show larger median and modal values than layer clouds in both areas, but in the Pacific coast area, the largest extreme values are in layer clouds.

Due to inaccuracies in the multicylinder determinations of large values of mean-effective diameter any indicated values over 35 microns are quite uncertain. The shape of the distribution curves, however, gives a reasonable basis for inferring that values of mean-effective diameter exceeding 50 microns occur in about 1 percent of Pacific coast clouds, although the actual values cannot be reliably measured. The fact that precipitation sometimes occurs in maritime climates without the appearance of the ice phase is further evidence of the possibility of the formation of large drops. In view of these facts, it is believed that values of mean-effective drop diameter exceeding 100 or even 200 microns might occasionally be encountered in coastal areas or over the sea.

It has been observed that unusually large values of mean-effective diameter are associated with low values of liquid water content and that the values of drop diameter associated with high values of liquid water content do not differ greatly from the average. Hence the designer of ice-protection equipment must provide for two types of conditions: high values of liquid water content associated with average values of drop diameter, and high values of mean-effective diameter associated with low liquid water content.

Since the maximum heating requirements for ice protection are associated with maximum values of liquid water content, it would appear reasonable to use an average value of drop size, for example, 15 to 20 microns for the calculation of total heating requirements. On the other

hand, since values of drop diameter from about 25 to 40 microns occur in about 5 percent of clouds it would seem advisable to consider drop diameters of 30 to 40 microns in determining the extent of areas to be heated.

In view of the facts that accurate and reliable measurements of extreme values of drop diameter are not now available and that the frequency of encountering such conditions is uncertain, it would probably not be necessary to consider values of mean-effective diameter greater than about 50 microns as design criteria until reliable data become available, unless experience should indicate that designs based on smaller values are inadequate.

In a study of the distribution of liquid water in clouds as a factor in aircraft icing, it is convenient to divide all clouds into two general classes, cumulus clouds and layer clouds. Cumulus clouds are large in vertical extent, small in horizontal area, and cover only a relatively small fraction of the total air mass. Layer clouds may be further divided into three types; first, stratus and strato-cumulus which generally form near the surface and rarely extend to more than 6 or 7 thousand feet above the ground; second, alto-cumulus, consisting of layers at higher levels which may be quite extensive. These layers are usually less than 2,000 feet in vertical extent and only rarely exceed 3,000 feet. The thicker layers usually show a strong tendency to change to ice crystals. The third main type of layer cloud is alto-stratus. These clouds are usually associated with large storm areas and are often very large both in vertical and horizontal extent. Alto-stratus clouds do not cause appreciable icing as they are composed almost entirely of ice crystals.

Figure 4 presents frequency distributions of observed values of liquid water content in layer-type clouds. These data have been divided into three groups on the basis of altitude: first, observation from below 10,000 feet pressure altitude, second observation above that level, and third, the highest altitude range for which enough observations were available to give some idea of average conditions. Looking first at the data for eastern U. S., it is noted that a large majority of the observations were at altitudes below 10,000 feet, due to the predominance of strato-cumulus clouds formed in the upper part of the surface turbulence layer. Actually more than half of all the observations were in the altitude interval between 3,000 and 6,000 feet. The alto-cumulus clouds in the region above 10,000 feet show a lower average liquid water content and low relative frequencies of high values. This tendency toward lower values continues in the small groups of 12 observations from above 14,000 feet.

The data from the Pacific coast and Plateau area show the effects of higher terrain. The zone of strato-cumulus clouds extends to above

10,000 feet in this area and as a result there is not much difference in the distribution for altitudes above and below 10,000 feet. The observations from the highest altitudes at which data are available, however, show the same tendency towards lower values of liquid water content that was noted in the data for eastern U. S.

In order to make a reasonable estimate of conditions to be expected at higher altitudes it is well to consider the physical processes of cloud formation in search of some reliable basis for extrapolation from the available data. With the exception of alto-stratus cloud systems, layer clouds are generally formed by lifting through a limited altitude range, rarely exceeding 3,000 feet above the condensation level. If it is assumed that the average vertical displacement which occurs during the formation of layer-type clouds is independent of altitude and temperature, then the liquid water content would be expected to diminish with temperature in conformity with the decrease in water vapor available for condensation.

It is also to be expected that average and extreme values of liquid water content should be influenced by the probability of the formation of ice crystals, since the transformation of water to ice results in an immediate and rapid reduction in the liquid water content. There is considerable controversy at present concerning the mechanism of ice formation in clouds, but it is generally agreed that the relative frequency of occurrence of ice crystals increases as the temperature is reduced. At the temperatures which prevail at altitudes above 20,000 to 25,000 feet, layer clouds are usually composed of ice crystals. The supercooled cloud layers which do occur at these levels are usually of small vertical extent and low liquid water content. There appears to be a strong tendency for thicker and more dense layers to go over into ice crystals.

Figure 5 shows the percentage of layer clouds containing measurable liquid water in which ice crystals were also present. Unfortunately, quantitative data are not available on the relative frequency of layer clouds composed entirely of ice crystals, but the general impression from many observations is that at low temperatures these are more prevalent than with mixed or liquid clouds. These data indicate that in the temperature range near -10° F the frequency of ice crystal formation increases rapidly.

These considerations would lead us to expect that the liquid water content of layer clouds would continuously diminish with lower temperature, this decrease being especially rapid in the neighborhood of $+10^{\circ}$ F. Figure 6 presents the results of an analysis of data from layer clouds in eastern U. S. Frequency distributions of the greatest value of liquid water content observed during each encounter with icing were obtained for temperature intervals of 10° F. These distributions were fitted to Gumbel's extreme-value distribution curve to obtain the most probable

maximum value per encounter (the mode) and the greatest value to be expected in 20 encounters (the 95 percentile). These quantities were then plotted as functions of temperature and the curves extrapolated to -40° F. The results are about what was to be expected except for the decrease in maximum liquid water content at temperatures close to freezing. This effect is believed to be due to the fact that the observations at higher temperature were often so close to the ground that there was not sufficient lifting to produce high values of liquid water content. The decrease in liquid water content at temperatures near 10° F is shown very clearly.

The extrapolated portion of these curves covers the temperature interval from -10° to -40° F which is the range in which icing is most likely to occur at altitudes between 20,000 and 30,000 feet. This extrapolation is, of course, uncertain but it gives a rough idea of conditions to be expected at high altitudes. The curves are terminated at -40° since recent laboratory investigations have shown that ice crystals are almost certain to occur at temperatures below -40° F. Since the liquid water content in layer clouds is primarily dependent on temperature rather than altitude, a considerable variation with season and latitude is to be expected. It is estimated that in tropical regions and in the U. S. during summer maximum probable values would be $.5 \text{ g/m}^3$ at 20,000 feet and $.1 \text{ g/m}^3$ at 30,000 feet. In northern latitudes and in the U. S. during winter, the estimated maximum values are less than $.2 \text{ g/m}^3$ at 20,000 feet and zero at 30,000 feet.

Consider now the problem of estimating the liquid water content of cumulus clouds at high altitudes. Frequency distributions of liquid water content in cumulus clouds are shown in Figure 7. The data for the Pacific coast show higher average and extreme values for the altitudes above 10,000 feet, with a tendency for high extreme value evident even above 14,000 feet, although the average is lower in this case. These data cannot be used as a basis for extrapolation to higher altitudes, however, since clouds of this type in this area are common only in winter and spring and seldom extend to altitudes much above 15,000 feet.

In the data from eastern U. S. and the plateau area, the number of observations from below 10,000 feet were too small to provide a representative sample. Data from higher altitudes from both areas were combined since both contained observations extending to considerable altitudes and together they provide a sample large enough for analysis. These distributions, unlike those from the Pacific coast, show a tendency for lower extreme as well as average values at the maximum altitudes.

The problem of estimating the maximum liquid water content at high altitude is more difficult for cumulus and cumulonimbus clouds than for layer clouds. Since cumulus clouds are composed of air which has been

lifted from near the surface, the limitation on moisture content due to low condensation temperature which exists in layer clouds, does not apply in this case. Calculations based on adiabatic lifting, without mixing or precipitation, indicate that extremely high values of liquid water content would be found at altitudes of from 20 to 30 thousand feet. In actual clouds, however, mixing with dry air from the environment and the formation of solid precipitation both act to reduce the liquid water content, so that in practice, the theoretically-possible high values are very unlikely to be encountered. It has been estimated that the maximum values of liquid water content likely to occur under extreme circumstances are 5 g/m^3 at 32° F . and 4 g/m^3 at 14° F . Such conditions could occur only in cumulus clouds formed of extremely warm and moist air originating near the surface and extending to 20,000 to 25,000 feet without precipitation. They would be highly localized and of brief duration and limited to certain geographical areas and seasons.

At lower temperatures, the reduction of liquid water content due to the formation of ice crystals is a factor of increasing importance, as shown in Figure 8. This figure gives the frequency of observation of ice crystals in cumulus clouds, expressed as the percentage of the total number of observations with measurable liquid water content. A high probability of ice formation is indicated for temperatures below about -5° F . Visual observations of individual cumulus clouds and a study of lapse time motion pictures of growing cumulus clouds indicate that when the rising columns reach an altitude where the temperature is in the neighborhood of 0° F , the transformation to ice crystals is usually evident within about 10 or 15 minutes, unless the cloud is dissipated in a shorter time by mixing with the environment. Under conditions of strong convective activity, extending to altitudes where the temperature is below 0° F , the upper portion of most clouds are composed of ice crystals or ice and water mixed, while only the most recently formed and actively-growing are composed mainly of liquid water.

Additional information concerning the icing conditions to be expected in summer cumulus clouds at high altitudes is contained in the report of the Thunderstorm Project. Icing was reported in only about one-half of the traverses at altitudes of from 20,000 to 26,000 feet, while heavy icing was reported in about 5 percent. It may be inferred from this that in about one-half of the clouds, the liquid water had been almost entirely transformed to ice, while only 5 percent were relatively unaffected by ice formation. Moreover, concerning heavy icing, the report states "Heavy icing was encountered very infrequently, and on no occasion during the two seasons of operation did ice accumulate to such an extent as to make impossible safe flight in the P-61-C airplanes. In almost every instance, the airplanes were in the clear air between traverses for a period sufficiently long to allow the ice to evaporate." The principal reason for the small total ice accumulation is the small size of the individual areas of heavy icing.

Radar data analyzed by the Thunderstorm Project have been used to estimate the total percentage of cumulonimbus cloud cover at various levels in conditions of airmass Thunderstorm formation. The results are shown in Figure 9. These curves should not be regarded as precise, due to several approximations and assumptions involved in the analysis, but they are believed to provide a reliable indication of the order of magnitude of cumulonimbus cloud cover and its variation with altitude. The solid curves represent average and maximum radar cloud coverage, while the dashed curves represent visual cloud area on the basis of the somewhat doubtful assumption that the average ratio between radar and visual area, as determined by airplane flights at 10,000 feet, is applicable at all altitudes. Since heavy icing occurred in only 5 percent of high-altitude traverses, it may be inferred that areas of heavy icing amount to only 5 percent or less of the areas of cloud cover shown here. Thus, under conditions of strong convective activity, heavy icing conditions would cover less than 1.5 percent of the airmass at 20,000 feet and less than 0.5 percent at 30,000 feet.

Another important point in connection with icing conditions in cumulus clouds is the effect of kinetic heating. For example, at a true airspeed of 400 mph, kinetic heating will prevent icing at temperatures above 16° F. The formation of ice crystals, on the other hand, may be expected to reduce greatly the frequency of occurrence of high values of liquid water content at temperatures below -5° F. This leaves the interval from 16° F to -5° F as the most probable temperature range for severe icing for high-speed airplanes. Under conditions favorable for the growth of summer cumulus clouds, the corresponding pressure-altitude range is from about 20,000 to 26,000 feet.

Although it is believed possible that values of liquid water content as high as 4 g/m³ may sometimes occur in this temperature range, it is very highly improbable that such conditions would be encountered during normal operations.

Figure 10 shows the values of liquid water content and drop size chosen for use in the calculation of heat requirements in the following paper (Part 8). These values are based on data for layer-type clouds. The first condition is somewhat milder than the heaviest icing condition to be expected in layer clouds below 10,000 feet, but it is believed to be adequate in view of the fact that the airplane will be below 10,000 feet for only a small part of the time. The second condition is conservative in view of the fact that it, too, applies only to climb and descent. The third and fourth conditions apply to the high-altitude region for which conditions must be estimated. They both are believed to be quite conservative as to liquid water content but perhaps not as to drop size.

An ice protection system designed for these conditions would in all probability function adequately in practically all icing conditions likely

to be encountered in layer-type clouds. It should be remembered, however, that occasional encounters with cumulus clouds may occur. Though such encounters would be infrequent and of short duration, they would produce a very severe overloading of the anti-icing system, and would probably result in the formation of residual ice on wing and tail surfaces back of the heated areas. The questions of what effect such ice formations might have on performance, and how they might be removed if the effect is serious, are problems deserving careful consideration. Similar problems may arise in connection with infrequent encounters with clouds composed of very large drops.

To summarize, icing conditions at high altitudes occur in two cloud types; alto cumulus layers with large horizontal extent, small vertical thickness, and low liquid water content; and cumulus and cumulonimbus clouds with small horizontal area, great vertical extent, and highly variable liquid water content with a small percentage of clouds having high maximum values of liquid water content.

Prolonged flight in alto-cumulus layers may easily be avoided in most cases by a change of altitude, since the layers are small in vertical thickness. On the other hand, the young, rapidly-growing cumulus clouds with high liquid water content are easily recognized by their appearance, and since they cover only small areas, they probably can be circumnavigated in most cases, at least during daylight hours. The total percentage of time in icing conditions during high-altitude flights, can thus probably be reduced to very low values by suitable meteorological navigation.

Just how much can be accomplished in this manner in reducing both the maximum intensity and total duration of icing encounters must be determined by flight experience in actual operating conditions. It is therefore highly desirable that records of liquid water content be obtained during regular transport operations. Such records would provide the data necessary for the accurate determination of the probability of encountering various values of liquid water content, the probable extent of icing encounters and the percentage of flight time in icing.

To meet the need for data of this kind, the Lewis Flight Propulsion Laboratory has developed two types of recording instruments for measuring liquid water content. These instruments are now being installed on airline planes for the collection of data during normal flight operations. Figure 11 shows one of these instruments, which is a modification of the rotating-disk type of icing rate meter which was originated at the Massachusetts Institute of Technology. The ice which forms on the front edge of a rotating disk is measured by a thickness gage and removed by a scraper as it passes around the rear side.

Figure 12 shows the other instrument, a pressure-type instrument developed at the Lewis Flight Propulsion Laboratory. This device consists of a tube with a series of small holes facing the air stream. When ice formation plugs the holes, the decrease in pressure turns on a heating current which melts the ice. When the holes are clear, the increase in pressure turns off the heat and the cycle is repeated. The length of time required for the ice to form is used as a measure of the icing rate. The heating cycle is recorded on a film and is also indicated by a light on the instrument panel which gives the pilot a useful visual indication of the icing rate.

These, and perhaps other instruments, when used during regular operations, will provide the data necessary for the design of anti-icing systems which will provide adequate protection with the lowest possible penalties in terms of performance and payload.

**CRITICAL CONDITIONS FOR ICE FORMATION
ON AN UNHEATED AIRPLANE**

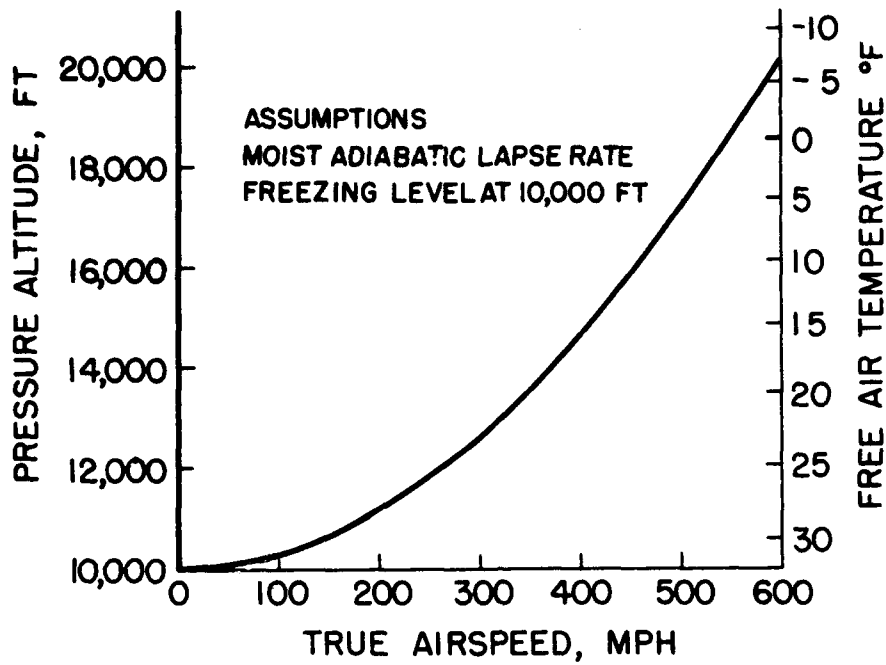

Figure 1

**FREQUENCY DISTRIBUTIONS OF CLOUD-DROP DIAMETER
IN LAYER-TYPE CLOUDS IN EASTERN U.S.**

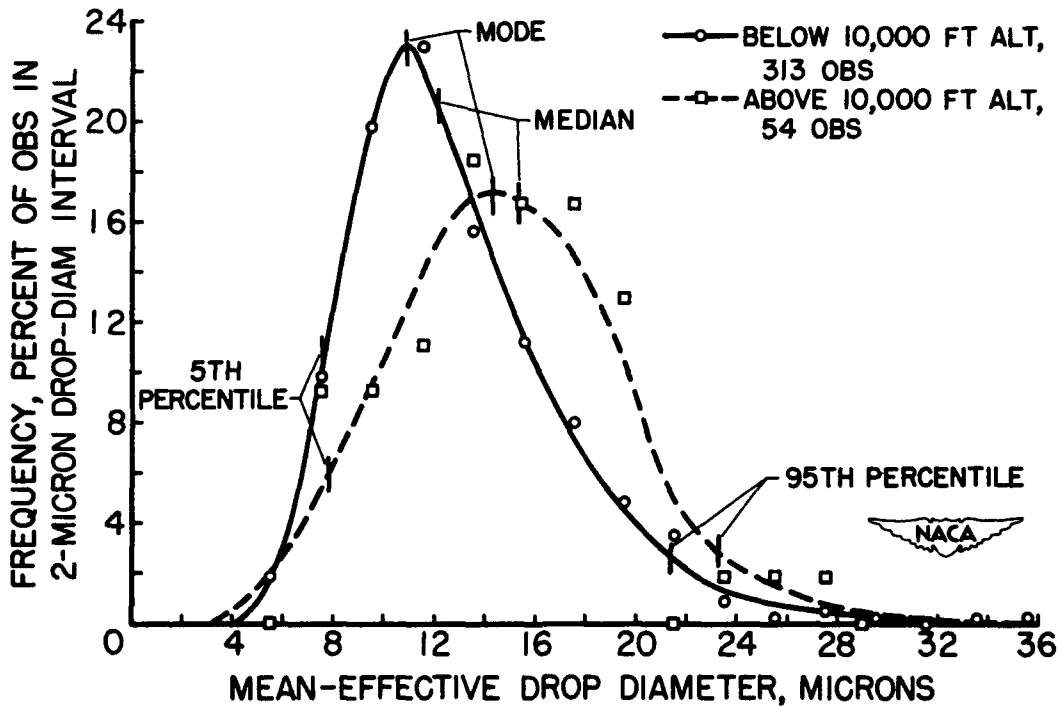

Figure 2

STATISTICAL DATA ON CLOUD DROP SIZE

GEOG. AREA (U. S.)	CLOUD TYPE	NO. OF OBS.	ALTITUDE RANGE	DROP DIAMETER, MICRONS				
				MEDIAN	MODE	PERCENTILES		
						5TH	95TH	90TH
EAST	LAYER	313	1000 TO 10,000 FT	12.1	10.9	7.5	21.4	30
EAST	LAYER	54	10,000 TO 18,000 FT	15.3	14.3	7.8	23.2	29
PAC. COAST	LAYER	159	4000 TO 20,000 FT	16.7	13.2	8.1	44	67
PLATEAU & EAST	CUMU- LUS	108	5000 TO 23,000 FT	16.2	14.5	9.5	27.5	36
PAC. COAST	CUMU- LUS	220	4000 TO 18,000 FT	19.5	20	8.8	36	52



Figure 3

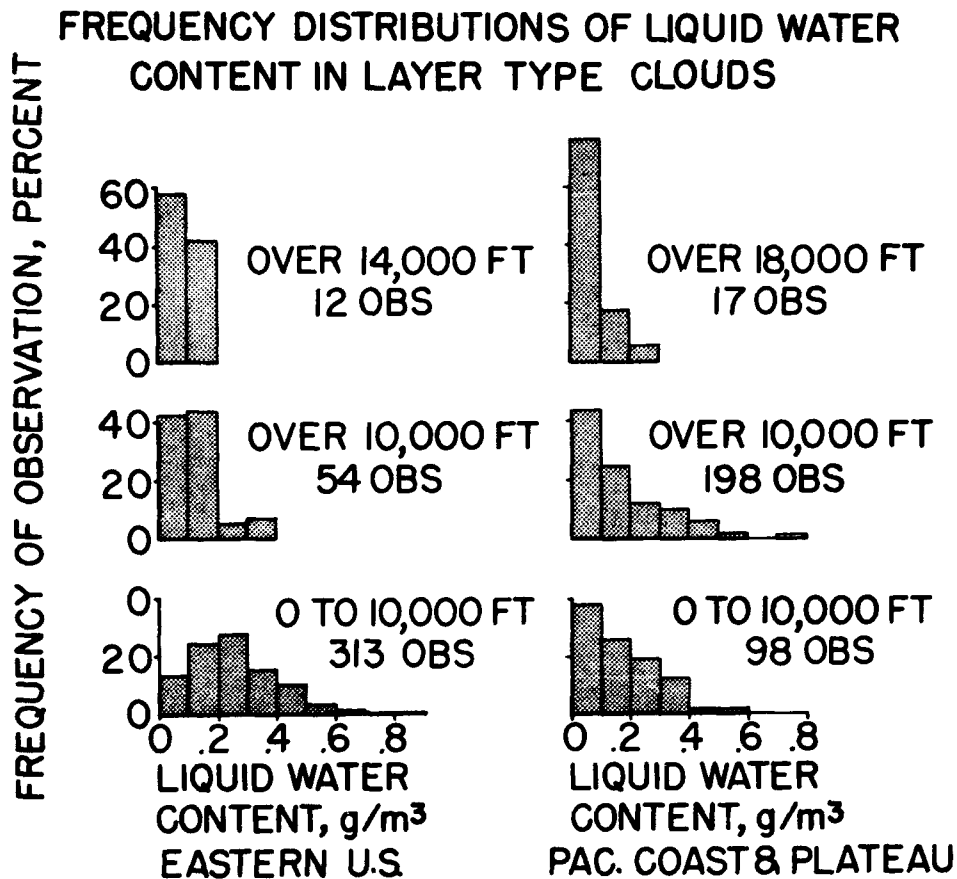

Figure 4

FREQUENCY OF ICE CRYSTALS IN LAYER CLOUDS
WITH MEASURABLE LIQUID WATER

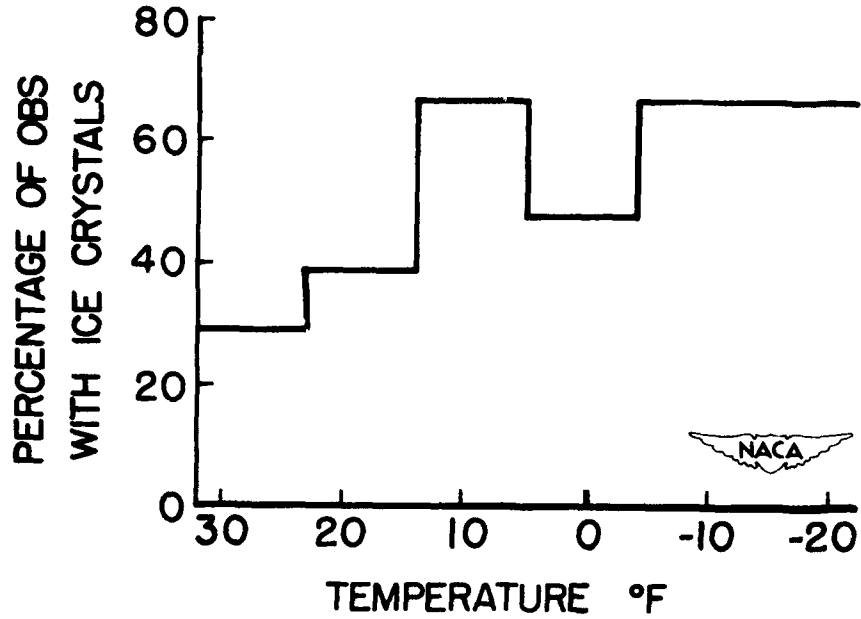

Figure 5

RELATION BETWEEN MAXIMUM LIQUID WATER CONTENT AND
TEMPERATURE IN LAYER-TYPE CLOUDS (EASTERN U.S.)

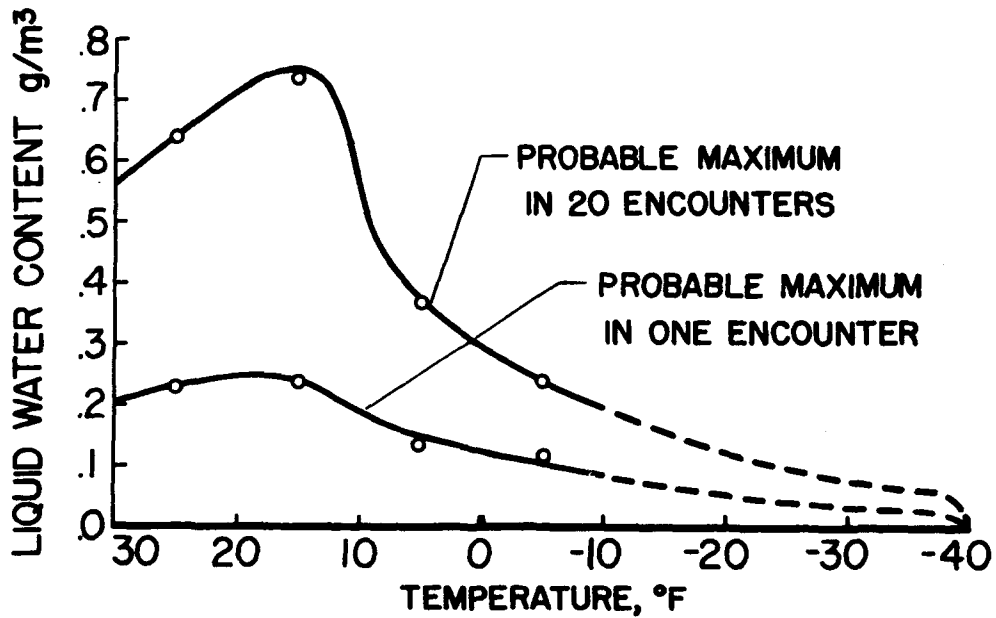

Figure 6

FREQUENCY DISTRIBUTIONS OF LIQUID WATER
CONTENT IN CUMULUS-TYPE CLOUDS

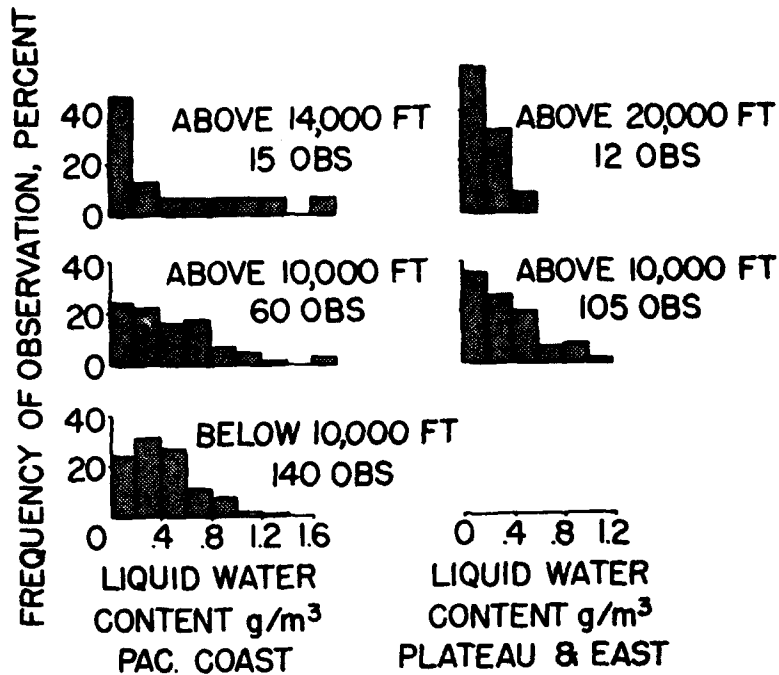

Figure 7

FREQUENCY OF ICE CRYSTALS IN CUMULUS CLOUDS
WITH MEASURABLE LIQUID WATER

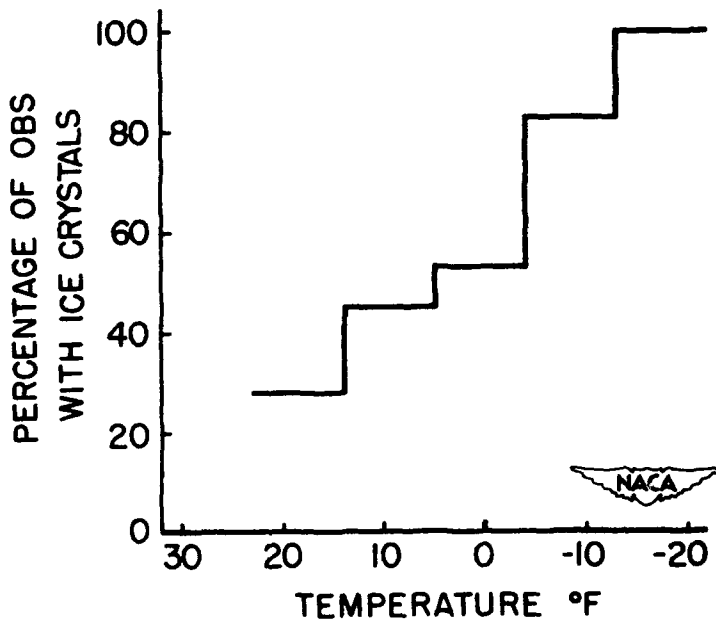

Figure 8

VERTICAL DISTRIBUTION OF RADAR AND VISUAL CLOUD COVERAGE UNDER AIR-MASS THUNDERSTORM CONDITIONS

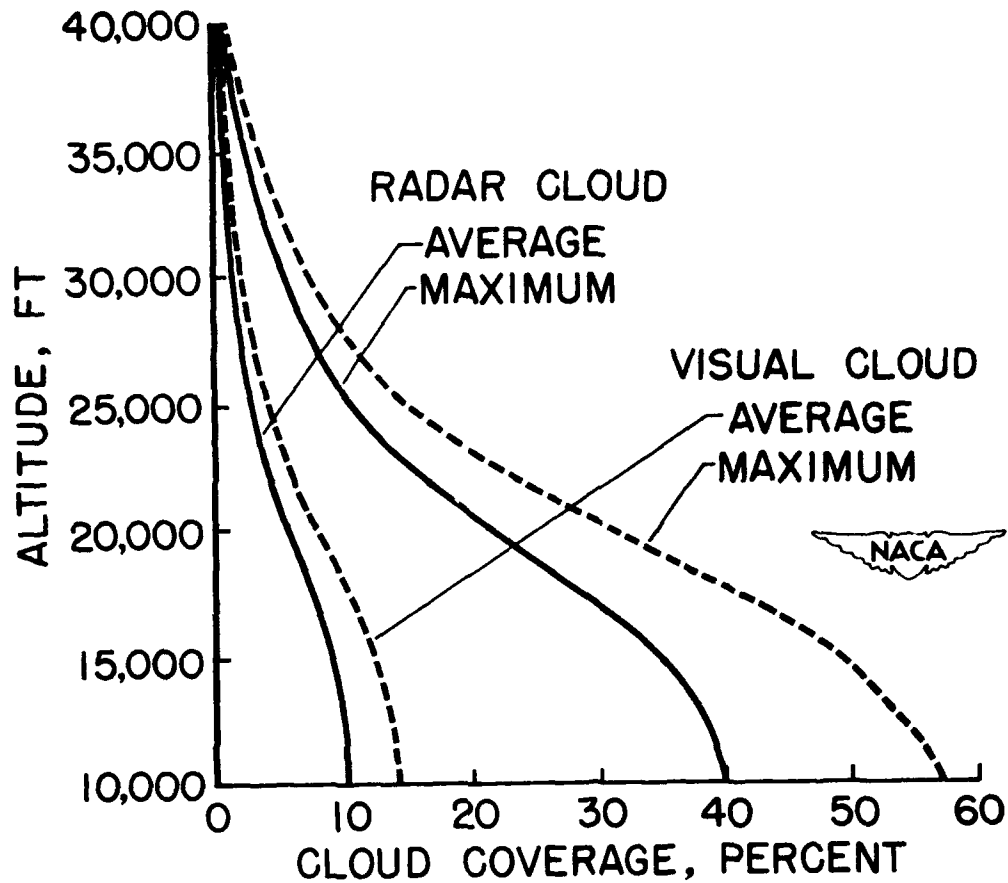

Figure 9

ASSUMED ICING ATMOSPHERE FOR GAS-TURBINE POWERED TRANSPORT

ALTITUDE (FT)	TEMP. (°F)	DROP SIZE (MICRONS)	LIQUID WATER (GM/CU M)
0 - 10,000	20	15	.6
10,000 - 20,000	0	20	.4
20,000 - 30,000	-25	15	.2
30,000	-40	15	.1

Figure 10

ICING RATE METERS ON B-25

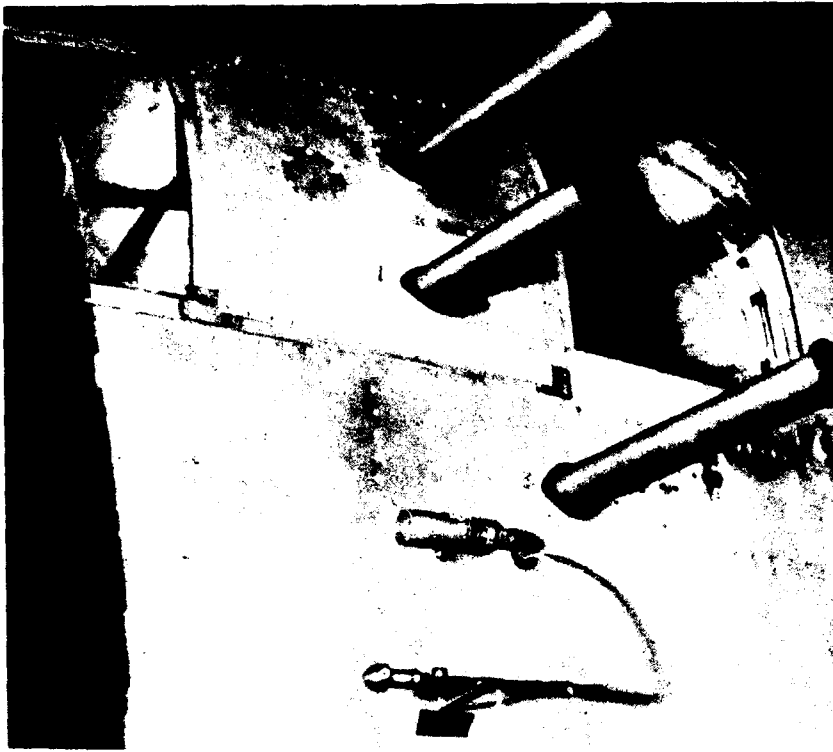

Figure 11

NACA PRESSURE-TYPE ICING RATE METER

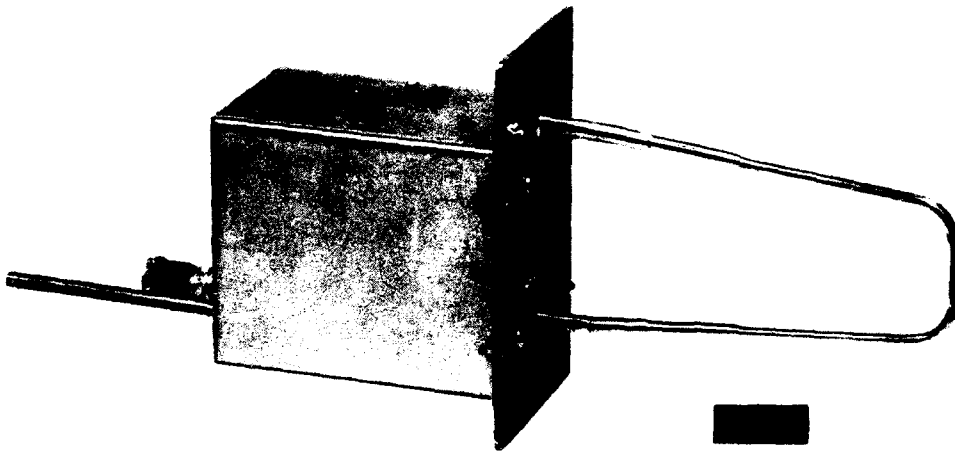

Figure 12

NACA
C-28453
8-14-50

SECRET

SECRET

8. THERMAL ICE PROTECTION FOR HIGH-SPEED TRANSPORT AIRPLANES

By Thomas F. Gelder and Stanley V. Koutz

SOME ASPECTS OF AIRCRAFT SAFETY - ICING,

DITCHING AND FIRE

8. THERMAL ICE PROTECTION FOR HIGH-SPEED

TRANSPORT AIRPLANES

By Thomas F. Gelder and Stanley L. Kutz

Lewis Flight Propulsion Laboratory

The need for protecting aircraft against icing and the operation of current thermal methods of protection in the air-transport operation field are well known. The advent of the high-speed, high-altitude, gas-turbine-powered transports presents certain new considerations in the attainment of protection and the operation of these aircraft in icing conditions. The purpose of this paper is to discuss and evaluate these problems by re-examining the methods of protection and the heating requirements, and then to determine the cost in terms of airplane performance and operational penalties of providing icing protection.

The effect of speed on the icing protection problem should be considered. The variation in airfoil heating requirement in Btu per hour per foot span with flight speed is illustrated in figure 1. The speed at which the minimum surface temperature attains 32° F because of frictional or aerodynamic heating is also indicated. Attainment of this temperature due to speed alone would eliminate the need for icing protection. A flight speed of approximately 640 miles per hour is necessary in an icing cloud at 15,000 feet and 0° F to realize this free protection. Inasmuch as this flight speed is above that presently being considered for turbine powered transports, protection probably will be required in cruise as well as in climb and descent. Below the critical speed, the heat required to evaporate the water increases with increasing flight speed. These requirements are based on evaporating the water upon impingement with the airfoil in an icing cloud with a liquid-water content of 0.4 gram per cubic meter and a drop size of 20 microns. Because of the direct increase in rate of water interception with speed, the heat required at 500 miles per hour is about four times that at a flight speed of 250 miles per hour; this lower speed is representative of several current transports. When the same icing condition and a fixed flight speed

are assumed, the total heat required to evaporate the water can also be shown to increase with altitude. At altitude, a greater percentage of water will strike the airfoil because the reduced drag forces on the water droplets act to deflect them out of the path of the advancing airfoil. Fortunately, the cloud liquid-water content generally decreases with increasing altitude, and the maximum heating requirement for complete evaporation of the intercepted water usually occurs in the medium altitude range, that is, about 15,000 feet

Since present hot-gas wing-heating designs provide protection by evaporating the intercepted water over a finite area, a marked increase in heat required with speed and altitude is representative of that to be expected from applying such a system to protect the high-speed turbine-powered transport. It is apparent that the 400 percent increase in heating requirement due to increasing the speed from 250 to 500 miles per hour makes it desirable to obtain a more economical means of protection or utilize a heat source that has a minimum effect on airplane operation. Current research at the NACA Lewis laboratory has indicated that a large savings in heat can be realized by the use of a cyclic de-icing system. With this system, instead of evaporating the intercepted water, small amounts of ice are allowed to form on the surface; heat is then applied to melt quickly the bond between the ice and the surface thereby allowing the ice to be removed by aerodynamic forces. After removal of the ice, heating is terminated, the surface temperature drops, and ice reforms. When this process is repeated in a regular cycle, small portions of the entire airplane can be de-iced in succession.

A short movie presented at the conference illustrates electric cyclic de-icing in the icing research tunnel of the Lewis laboratory. The first scene shows the resultant ice formation on the leading edge of a low drag airfoil after an icing period of 15 minutes with no heat. The next sequence presents an unsuccessful attempt at de-icing. Following a 3-minute icing period at 275 miles per hour, 10° F, and 0.5 gram per cubic meter, the heat is turned on for 15 seconds. Failure to remove the ice was due to inadequate heating which amounted to 8 watts per square inch over the first 10 percent chord. In the next sequence, successful de-icing is achieved at the same conditions but with a different heat input. In this case, the heat densities varied from 14 watts per square inch near the leading edge to 8 watts per square inch at the aft portion of the heated area. A continuously heated strip 1/2 inch wide at the stagnation point was also employed with a heat

SOME ASPECTS OF AIRCRAFT SAFETY - ICING,

DITCHING AND FIRE

8. THERMAL ICE PROTECTION FOR HIGH-SPEED

TRANSPORT AIRPLANES

By Thomas F. Gelder and Stanley L. Koutz

Lewis Flight Propulsion Laboratory

The need for protecting aircraft against icing and the operation of current thermal methods of protection in the air-transport operation field are well known. The advent of the high-speed, high-altitude, gas-turbine-powered transports presents certain new considerations in the attainment of protection and the operation of these aircraft in icing conditions. The purpose of this paper is to discuss and evaluate these problems by re-examining the methods of protection and the heating requirements, and then to determine the cost in terms of airplane performance and operational penalties of providing icing protection.

The effect of speed on the icing protection problem should be considered. The variation in airfoil heating requirement in Btu per hour per foot span with flight speed is illustrated in figure 1. The speed at which the minimum surface temperature attains 32° F because of frictional or aerodynamic heating is also indicated. Attainment of this temperature due to speed alone would eliminate the need for icing protection. A flight speed of approximately 640 miles per hour is necessary in an icing cloud at 15,000 feet and 0° F to realize this free protection. Inasmuch as this flight speed is above that presently being considered for turbine powered transports, protection probably will be required in cruise as well as in climb and descent. Below the critical speed, the heat required to evaporate the water increases with increasing flight speed. These requirements are based on evaporating the water upon impingement with the airfoil in an icing cloud with a liquid-water content of 0.4 gram per cubic meter and a drop size of 20 microns. Because of the direct increase in rate of water interception with speed, the heat required at 500 miles per hour is about four times that at a flight speed of 250 miles per hour; this lower speed is representative of several current transports. When the same icing condition and a fixed flight speed

are assumed, the total heat required to evaporate the water can also be shown to increase with altitude. At altitude, a greater percentage of water will strike the airfoil because the reduced drag forces on the water droplets act to deflect them out of the path of the advancing airfoil. Fortunately, the cloud liquid-water content generally decreases with increasing altitude, and the maximum heating requirement for complete evaporation of the intercepted water usually occurs in the medium altitude range, that is, about 15,000 feet

Since present hot-gas wing-heating designs provide protection by evaporating the intercepted water over a finite area, a marked increase in heat required with speed and altitude is representative of that to be expected from applying such a system to protect the high-speed turbine-powered transport. It is apparent that the 400 percent increase in heating requirement due to increasing the speed from 250 to 500 miles per hour makes it desirable to obtain a more economical means of protection or utilize a heat source that has a minimum effect on airplane operation. Current research at the NACA Lewis laboratory has indicated that a large savings in heat can be realized by the use of a cyclic de-icing system. With this system, instead of evaporating the intercepted water, small amounts of ice are allowed to form on the surface; heat is then applied to melt quickly the bond between the ice and the surface thereby allowing the ice to be removed by aerodynamic forces. After removal of the ice, heating is terminated, the surface temperature drops, and ice reforms. When this process is repeated in a regular cycle, small portions of the entire airplane can be de-iced in succession.

A short movie presented at the conference illustrates electric cyclic de-icing in the icing research tunnel of the Lewis laboratory. The first scene shows the resultant ice formation on the leading edge of a low drag airfoil after an icing period of 15 minutes with no heat. The next sequence presents an unsuccessful attempt at de-icing. Following a 3-minute icing period at 275 miles per hour, 10° F, and 0.5 gram per cubic meter, the heat is turned on for 15 seconds. Failure to remove the ice was due to inadequate heating which amounted to 8 watts per square inch over the first 10 percent chord. In the next sequence, successful de-icing is achieved at the same conditions but with a different heat input. In this case, the heat densities varied from 14 watts per square inch near the leading edge to 8 watts per square inch at the aft portion of the heated area. A continuously heated strip 1/2 inch wide at the stagnation point was also employed with a heat

density of 8 watts per square inch. The ice is quickly and cleanly removed within 5 to 10 seconds after the heat is turned on.

In order to evaluate the effect of employing a hot-gas or a cyclic electric de-icing system on the operation of a turbine-powered aircraft in icing conditions, a hypothetical turbojet transport (fig. 2) illustrates the magnitude of the problems involved. This airplane is assumed to have a gross weight of 125,000 pounds, a wing span of 158 feet, and a cruising speed of 500 miles per hour from an altitude of 30,000 feet. The plane is powered by four axial-flow turbojet engines placed in two nacelles, and each engine has a compressor pressure ratio of 5 and a rated thrust of 6000 pounds. It is assumed to climb to its cruising altitude at maximum thrust and the flight speed to give maximum rate of climb. This speed is approximately 350 miles per hour for all altitudes. The descent is also at 350 miles per hour. The leading edges of the wing and tail, the elements within the engine inlet, and the windshield are the critical components requiring icing protection considered in this discussion.

The icing atmosphere discussed in the previous paper through which this airplane is assumed to fly is summarized in figure 3. The variation in ambient temperature, liquid-water content, and drop size with altitude represents a compromise between the most frequent and extreme values obtained from the available icing data. Altitude up to 30,000 feet has been divided into three parts, the 30,000-foot condition represents cruise. The meteorological values in figure 3, taken for the purpose of illustration and, based on present flight data, provide a reasonable basis for the calculation of heating requirements and the evaluation of associated performance and operational considerations for the high-speed, high-altitude transport.

The total and component turbojet transport heating requirements in Btu per hour for three altitudes and two methods of thermal protection are presented in figure 4. Because calculations indicated the assumed icing condition from sea level to 10,000 feet was not critical, the heat requirements for altitudes below 10,000 feet are omitted.

All the hot-gas requirements illustrated are for continuous heating with wing and tail requirements being computed for a typical double-skin chordwise flow system designed to evaporate the intercepted water by 10 percent of chord. The engine components

and windshield requirements are based on maintaining the minimum surface temperatures just above freezing.

The electrical heating requirements are based on a conservative estimate of the performance of a cyclic de-icing system for wing and tail, and continuous electrical heating of engine components and windshield.

In all icing conditions investigation, the total airplane requirement using a cyclic electric system, varies from a minimum of about 10 percent at 15,000 feet to a maximum of approximately 30 percent at 25,000 feet of the hot-gas requirement. The maximum cyclic electric requirement occurs at 25,000 feet and is about 1,000,000 Btu per hour or 300 kilowatts. A considerable savings also appears possible for a cycled hot-gas system and the economical performance indicated for a cyclical method of protection prompts further study and development.

At present the cyclic system entails certain installation, maintenance, and operational problems. Pending the perfection of this method of protection, the requirements for continuous heating with hot gas will be further examined.

The continuous hot-gas requirement varies from a maximum of approximately 7,000,000 Btu per hour at 15,000 feet near midpoint of climb to a minimum of approximately 3,000,000 Btu per hour at 25,000 feet. The higher speed cruising condition requires 4,000,000 Btu per hour. For both the cyclic electric and continuous hot-gas requirements illustrated, the wing and the tail comprise over 80 percent of the total airplane requirements.

A suitable source of these large amounts of heat must be provided. Approximately 25 combustion heaters of the size used in present aircraft would be required to satisfy this maximum continuous heating load and obviously this would impose an unacceptable space and weight penalty. Because the turbojet engine generates large amounts of heat, it should be considered as a source of energy for icing protection. Hot air or gas may be bled from the compressor outlet, turbine inlet, or the tail pipe of a turbojet engine. Power may also be extracted from the shaft of the engine to drive electrical generators.

Use of the turbojet engine as an energy source, however, imposes performance and operational penalties. During climb, when the turbojet engines are operated at maximum power, the

extraction of energy results in a decrease in thrust and a consequent decrease in rate of climb. Figure 5 illustrates the decrease in rate of climb resulting from the use of several turbojet-engine energy sources at an altitude of 15,000 feet and a flight speed of 350 miles per hour. For the continuous hot-gas system, the climb penalties vary from about 40 percent using compressor-outlet bleed to approximately 4 percent using tail-pipe bleed. Less than 1-percent decrease in rate of climb results from use of shaft power to operate a cyclic electric system. Although turbine-inlet and tail-pipe bleed sources have a small effect on rate of climb as compared to the compressor-outlet bleed source, the presence of products of combustion and the necessity for mixing the hot gas with colder air will complicate their use in an anti-icing system. In contrast, the compressor-outlet air is uncontaminated and available at directly usable temperatures.

Because the vertical extent of several layers of icing clouds is generally less than 6000 feet, a turbine-powered aircraft during climb would be in an icing condition only a short time. The large loss in rate of climb entailed in the use of compressor bleed suggests the possibility of making the climb through the icing cloud without protection except for the engine components and then upon reaching the cruising altitude the protection system would be turned on and the ice removed. Calculations indicate, however, that the increased drag due to a 3-minute unprotected icing encounter near 15,000 feet would result in a climb penalty in the same order of magnitude as that caused by the use of compressor bleed for protection. In addition, the possible inability of a hot-gas system to remove the ice formation quickly enough to prevent runback and refreezing may result in a drag penalty for the remainder of the flight. It is therefore apparent that little or no benefit can be derived in rate of climb by allowing the aircraft to ice for even a short period of time. Also, because the duration of icing in climb will be small, these seemingly severe performance penalties will be experienced only briefly.

In the turbojet transport cruise condition, the engines are normally operated at less than maximum power so that heat or power can be extracted from the engine and constant thrust maintained by increasing the fuel flow. This increase in fuel flow together with the installed weight of the ice-protection equipment reduce the allowable pay load. The reduction in pay load as a function of the percent of flight time in which the anti-icing equipment is in operation on a long range high-altitude flight is shown in figure 6. The reduction in pay load at 0 percent flight time is

due to the installed weight of the equipment, and the slope of the curves is a measure of the fuel consumed in providing icing protection. The performance penalties for the hot gas systems are based on continuous heating; for the electrical system operating from shaft power, cyclic operation is assumed.

As stated in the previous paper, the existence of liquid water at an altitude of 30,000 feet is uncertain. If icing conditions do exist, the horizontal extent is believed to be small and the possibility of avoiding such clouds favorable. The anti-icing time will therefore be but a small percentage of the total flight time. Therefore, the merits of a heat source for providing protection during cruise should also be evaluated on the basis of short icing encounters where the installed weight is the primary consideration. On this basis, the hot-gas system operated from compressor-outlet bleed, tail-pipe bleed, or turbine-inlet bleed appear most favorable. The turbine-inlet curve, omitted for the sake of clarity, falls only slightly above the tail-pipe curve. The pay-load penalty indicated for a cyclic electric system employing shaft power is based on present weights and power requirements and if these can be reduced in future development, the use of a cyclic electric system will be more attractive.

The auxiliary power unit indicated in figure 6 consist of a small gas turbine unit operating as a gas generator. Although it is the lightest of the several auxiliary units investigated, it is obviously too heavy to make this source attractive. If, however, such an auxiliary power plant is needed for uses other than icing protection, a portion of its weight might be otherwise chargeable.

Ice protection has been discussed herein for climb and cruise conditions. Protection, however, may also be required during descent. Assuming the descent is at about the same flight speed as the climb, the heating requirements for each attitude would be approximately the same. The use of the turbojet engine as an energy source during descent presents more of a problem than previously indicated for the climb because of the decreased power and thus the decreased availability of heat during descent. A cyclic electric de-icing system could provide adequate protection during descent provided that the generators are designed to operate over a wide range of engine speeds, and the turbine-inlet and tail-pipe temperatures were sufficient to provide protection even with low engine power. Although use of compressor bleed in descent is inadequate to protect the entire aircraft, because of

the very low temperature available at the compressor outlet, serious icing in the engine could be prevented with this method. The vertical extent of possible icing clouds is small and the normal rate of descent large; therefore the time in icing during descent is even less than during climb. Furthermore, it would be possible at any time during descent to level out for a short period, increase the engine power, and de-ice the airplane.

Although the penalty on rate of climb is large for the compressor bleed source, its use with a hot-gas protection system is desirable because of the low installed weight and the freedom from products of combustion. The compressor-outlet bleed performance penalties just presented were based on a current turbojet engine with a rated compressor pressure ratio of 5. Engines to be developed for future use may operate at considerably higher pressure ratios. Figure 7 shows the effect of increasing the compressor pressure ratio on the change in rate of climb at 15,000 feet and 350 miles per hour. The penalty imposed on rate of climb lessens as the pressure ratio is increased, varying from about 40 percent for a pressure ratio of 5 to about 25 percent for a pressure ratio of 10, a change of 40 percent. The penalties on rate of climb due to use of turbine-inlet bleed, tail-pipe bleed, and shaft power extraction are inappreciably affected by variation in pressure ratio. Increasing the pressure ratio from 5 to 10 also results in a slight improvement in payload during the cruise condition. It appears, therefore, that compressor bleed should become even more attractive as a source of heat for ice protection of future turbojet transports using higher pressure ratio engines.

The preceding discussion has been related only to the turbojet-powered transport. Consideration of the icing protection problem of a turbine-propeller aircraft is also of interest. The primary difference in the icing protection problem between the turbine-propeller transport as compared to the turbojet involves the use of the turbine-propeller engine as an energy source. In a turbine-propeller engine the low pressure existing in the tail pipe is probably inadequate to force the hot gas through the anti-icing system and the extraction of energy from the remaining engine sources is more costly in terms of engine performance because the mass flow through the turbine-propeller engine will be less than that of a turbojet.

Evaluating an icing protection system for the turbine-propeller transport therefore warrants greater consideration of

the low performance penalty sources such as shaft power to operate a cyclic electric system or hot gas from the turbine inlet.

In conclusion, icing protection is required for the high-speed, high altitude, gas turbine-powered transport. Although the airplane heating requirements have been markedly increased from present day values by the introduction of the turbine-powered transport, several factors tend to alleviate this increased heating load. A sizeable reduction in these requirements is possible by the satisfactory development of cyclic system, using either electrical heating or hot gas. A suitable source for this energy is readily available in the turbine engine itself. The resultant performance or operational penalties incurred in extracting energy from the engine will be dependent on the source employed. The difficulties arising from the use of any one source can be obviated by employing a suitable combination of sources, as for example: engine protection from turbine-inlet bleed, or shaft power in conjunction with compressor bleed for cyclic or continuous protection of the wing and tail surfaces.

Although the performance penalties associated with providing icing protection from some of the available energy sources appear large during climb and descent of the aircraft, these penalties will probably be in effect for only a short time; and the icing conditions, if any, during cruise will be of small extent and the possibility of avoiding them favorable.

The exact nature of the ice protection system, its operation and cost will be dependent upon the specific characteristics of the airplane and engine, the flight plan, and the icing conditions it may encounter.

HEAT REQUIRED AT SURFACE TO EVAPORATE WATER UPON INTERCEPTION

65-212 AIRFOIL
CHORD, 15.7 FT

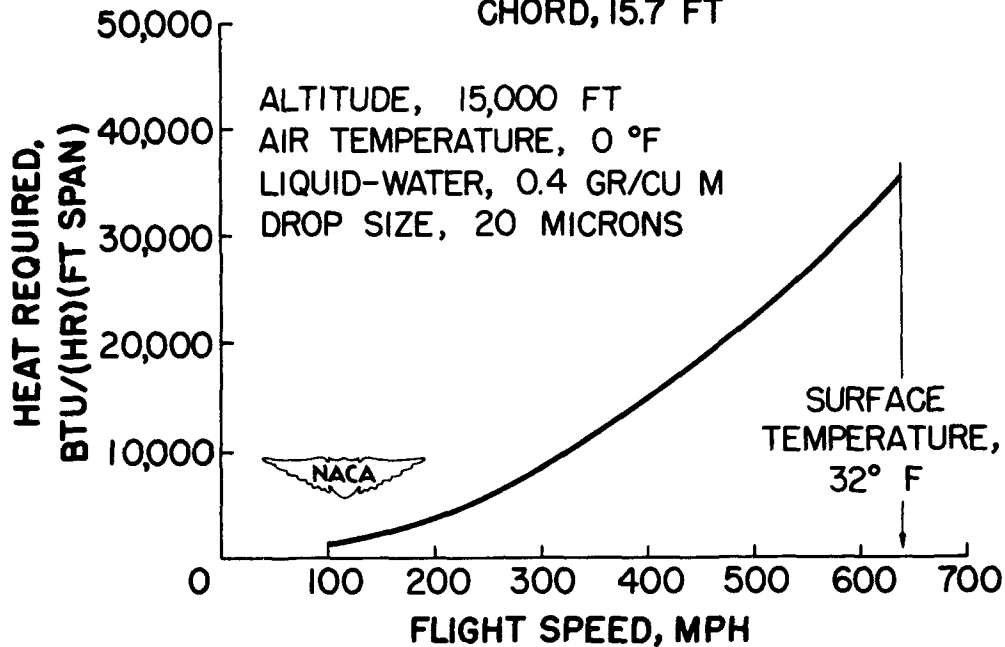
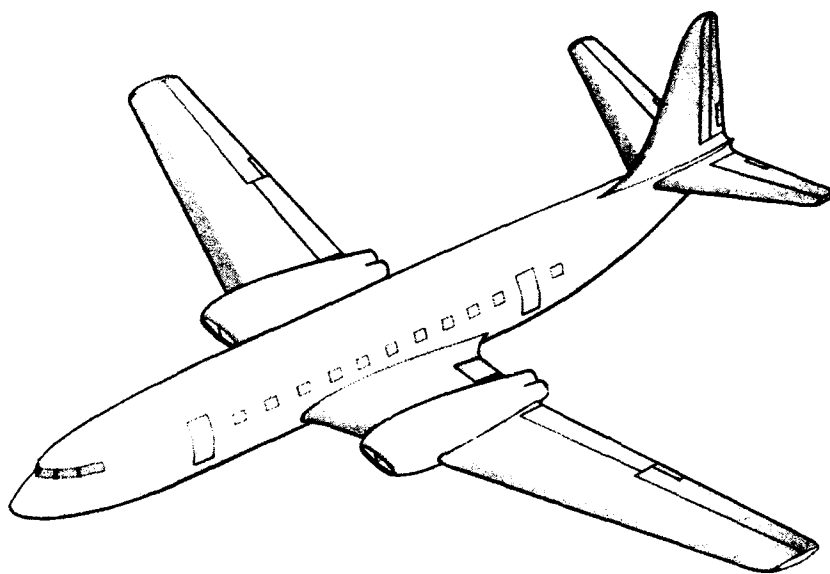

Figure 1

TURBOJET TRANSPORT AIRPLANE



GROSS WEIGHT - 125,000 LBS
WING SPAN - 158 FT
CRUISING SPEED - 500 MPH

Figure 2

**ASSUMED ICING ATMOSPHERE
FOR GAS-TURBINE POWERED TRANSPORT**

ALTITUDE (FT)	TEMP. (°F)	DROP SIZE (MICRONS)	LIQUID WATER (GM/CU M)
0 - 10,000	20	15	.6
10,000 - 20,000	0	20	.4
20,000 - 30,000	-25	15	.2
30,000	-40	15	.1

Figure 3

TURBOJET TRANSPORT HEAT REQUIREMENT

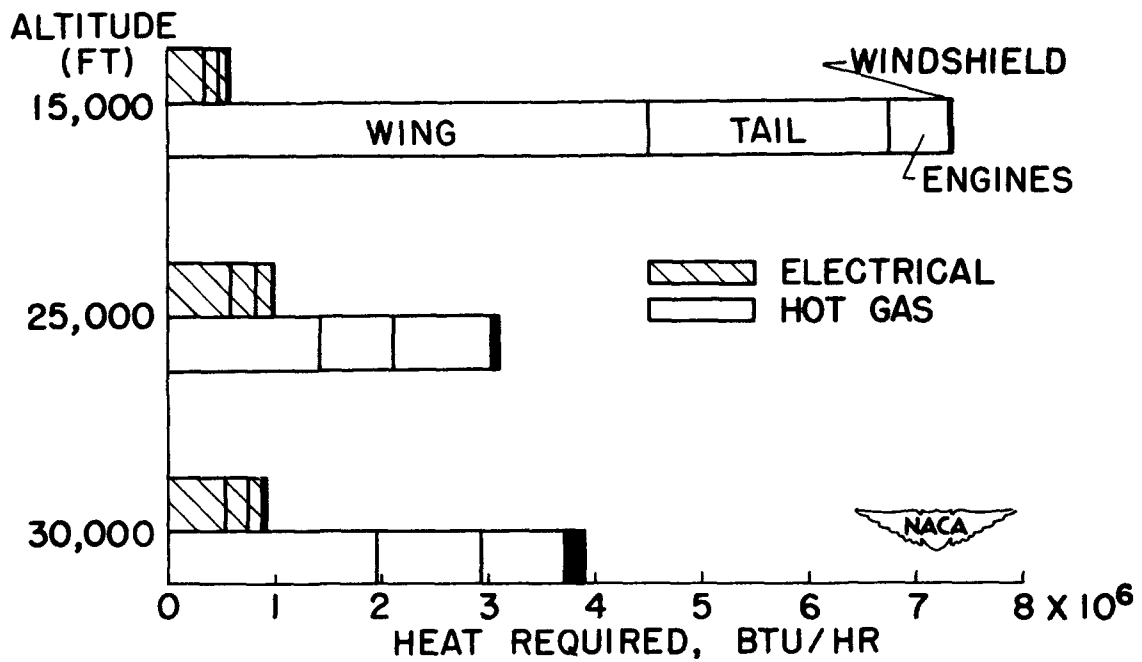

Figure 4

EFFECT OF ANTI-ICING ON TURBOJET TRANSPORT PERFORMANCE

15,000 FT 350 MPH

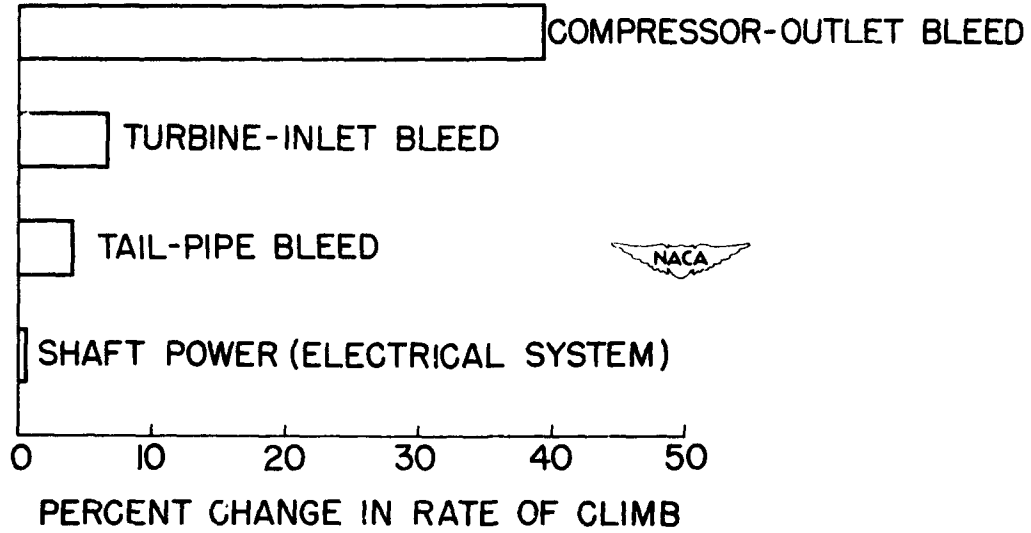

Figure 5

EFFECT OF ANTI-ICING ON TURBOJET TRANSPORT PERFORMANCE

3000 MILE CRUISE
INITIAL ALTITUDE, 30,000 FT

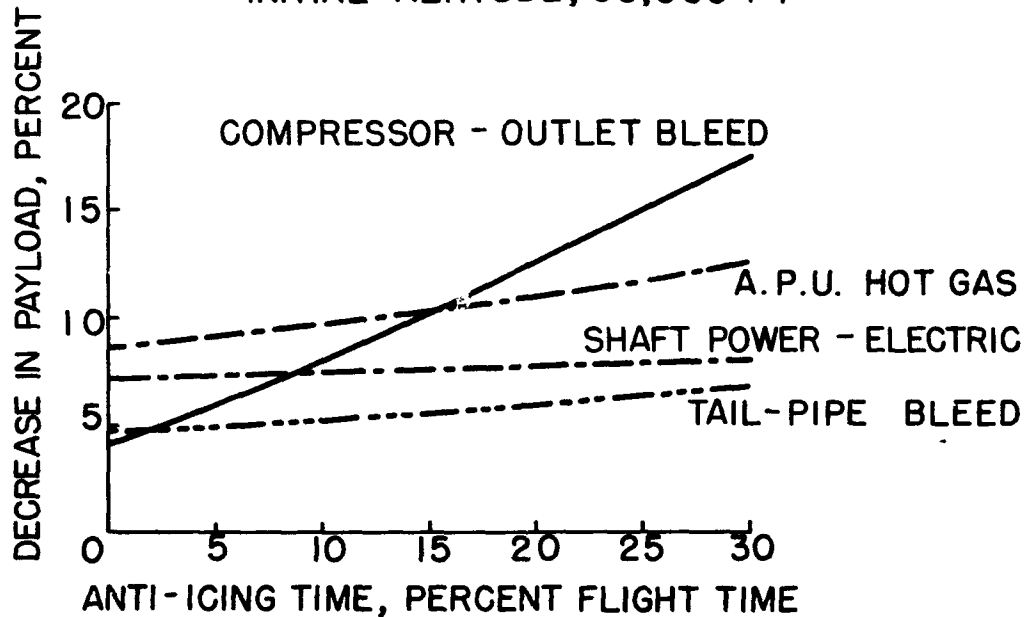

Figure 6

EFFECT OF ANTI-ICING WITH COMPRESSOR-OUTLET
BLEED ON TURBOJET TRANSPORT PERFORMANCE
15,000 FT 350 MPH

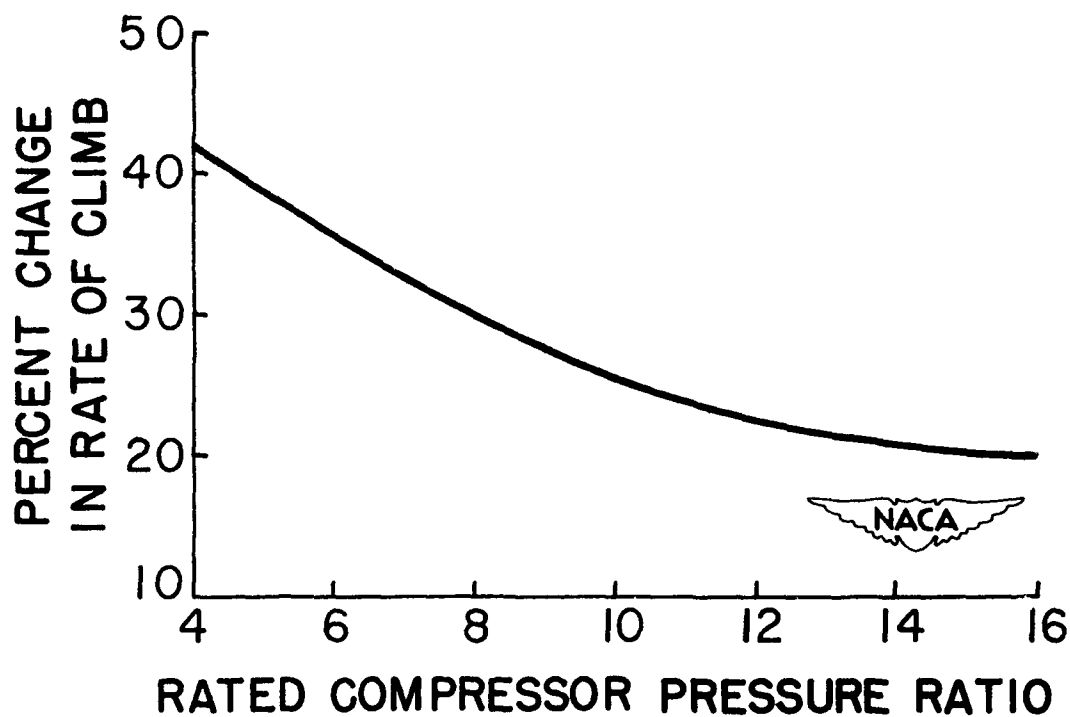

Figure 7

9. AIRCRAFT OPERATIONAL PROBLEMS INVOLVED IN DITCHING

By Lloyd J. Fisher

SOME ASPECTS OF AIRCRAFT SAFETY - ICING, DITCHING, AND FIRE

9. AIRCRAFT OPERATIONAL PROBLEMS INVOLVED IN DITCHING

By Lloyd J. Fisher

Langley Aeronautical Laboratory

This paper presents some of the operation problems associated with ditching and the effect of design parameters on ditching performance.

A ditching operation can be divided into four main parts: (1) landing, (2) escape from the airplane, (3) survival in the water, and (4) rescue.

The NACA has been mainly concerned with the landing operation. Consequently, the approach, landing technique, dynamic behavior, and structural damage during ditching, which have been investigated in detail, are the phases discussed.

Three types of motion are used herein to describe ditching behavior. One type of motion is called a dive. In this motion the airplane assumes a negative attitude and partially submerges. The decelerations are generally high. This is the most undesirable motion encountered and is most prevalent in bomber-type airplanes due to failure of the weak bomb-bay doors in the fuselage bottom. Another motion is called trimming up. This term is used to describe a positive rotation about the transverse axis that occurs soon after landing. It occurs with airplanes that have pronounced curvature on the aft fuselage and very frequently occurs with transport airplanes. The third type of motion is called a smooth run. In this behavior there is no apparent oscillation about any axis and the model gradually settles into the water as the forward speed decreases. This is the best ditching behavior and transports in general approach this type of motion.

Figure 1 summarizes a typical ideal landing configuration. It is realized that circumstances may be such that all the desirable features shown here cannot be achieved in every ditching. For example, if all engines have failed the ditching must necessarily be made without power. However, if fuel is running low and it is known that a ditching is inevitable the landing should be made before the fuel is exhausted so that a normal power approach can be used to give better control and lower speed. The lowest forward and vertical speeds possible are desirable as damage is intensified by increased speed. As much flap deflection should be used as adequate control and reasonable vertical speed permit. In order to reduce gross weight and

landing speed all disposable gear and cargo should be jettisoned. Remaining gear and cargo should be secured and no hatches or doors should remain open in the lower part of the fuselage. The landing gear should be retracted as an extended gear will cause high deceleration and diving. Generally a nose-high attitude is desirable. A near-level landing attitude sometimes causes an airplane to dive but in any case the high speed associated with a level landing usually produces high bottom loads and consequent damage. Care should be exercised to prevent stalling to avoid lack of control and the possibility of falling onto the water. This might produce excessive structural damage and such damage is the cause of most ditching difficulties.

In order to obtain the optimum ditching in a heavy sea, considerable skill is required by the pilot in making touch-down at the best point. The sea may be so irregular that a great amount of judgment will be needed in determining the predominant wave form. However, some principles that should be followed can be illustrated on a simple wave system, figures 2 to 4. It is usually best to land parallel to waves or swells unless a very strong wind is blowing in which case a landing into the wind may be best. In a landing parallel to the waves (fig. 2) the contact should ideally be made near the crest on the leeward side so that as the wave progresses the airplane will remain near the crest longer. The trough of waves (fig. 3) is less safe for first contact because of the possibility of getting a wing tip in a crest. If the wind is strong enough so that a cross wave landing (fig. 4) is best, the ideal situation is to make contact near the crest of the wave on the downward slope so that the airplane can in effect ease down the slope into the water. A contact on the upward slope will result in high impact loads and if the force is applied near the tail it might cause the airplane to nose into the next wave. The principles illustrated in figures 2 to 4 admittedly are difficult to follow, but the Coast Guard considers them feasible and has written them into its pilot's operational manual.

In a heavy sea even an airplane with very good ditching characteristics can be thrown into violent motions and receive extensive damage if touch-down is poorly executed. Figure 5 shows typical longitudinal decelerations for a transport model landed across waves and in calm water. A maximum value of about 6g is shown for 6-foot waves but this value can be exceeded in steeper waves. The maximum deceleration in $2\frac{1}{2}$ -foot waves is about 4g, practically the same as in calm water. For landings in calm water, across small waves, or parallel to large waves transports generally make fairly smooth runs and sustain less damage than other large airplanes such as bombers. The

primary reason for this is that transports have fewer weak doors in the bottom and the requirements of cargo floors and pressurization add to the fuselage strength. It would seem that much better ditching characteristics are needed in transports than in bombers because of the large number of untrained transport passengers involved.

In order to safeguard against injury even in a mild ditching, consideration needs to be given to the location of passengers in the airplane (fig. 6). No ditching stations should be just aft of a weak door or hatch in the fuselage bottom, as such a position is likely to be overwhelmed by water entering through the opening. The safest position is in the forward part of the fuselage, facing backward with one's back against a bulkhead or preferably in a seat faced backward. A properly tightened seat belt may be sufficient restraint even in seats facing forward but a much greater margin of safety would be obtained if the seats were faced backward. Seats and safety belts of course need to be strong enough to withstand the decelerations that may be encountered. In most ditchings the longitudinal decelerations will be less than 6g - a value that is tolerable to the human body if it is properly restrained. In those transports that have two decks, the upper deck provides the better ditching station. There is little likelihood of the floor of this compartment being flooded quickly since it probably will not be damaged and the wing will provide enough buoyancy to keep it above the water for a reasonable length of time.

When the airplane has come to rest it is important to get out promptly to avoid entrapment, as the airplane may sink quickly. Although there have been a number of ditchings in which the airplane floated for hours, the prediction of such extended floatation time would require a knowledge, not immediately available, of the total damage to the airplane. The only safe course is to get out quickly and rapid escape may be complicated by panic among the passengers, particularly if the escape hatches that are available appear to be inadequate. Escape hatches should be in the upper part of the fuselage (fig. 7) and should be positioned for exit onto the wing or directly to a life raft. Such exits are not usually available in transports in sufficient number to permit a rapid escape of a full load of passengers.

Design parameters having an influence on ditching characteristics (fig. 8) include wing location, landing flaps, tail-surface location, fuselage shape and strength, and protuberances. It is realized that an airplane is not designed solely for ditching. However, in any design the choice of parameters is made for a variety of reasons and it is intended here to show how such choice may effect ditching. Actually there have been airplanes having generally similar

air performance but with considerable difference in ditching performance so it is sometimes possible to obtain improvements in ditching without loss in other respects.

Figure 9 shows typical wing-and-fuselage combinations. Since a major portion of the buoyancy available for keeping the airplane afloat comes from the wing, it is undesirable to have the wing placed high with respect to the fuselage. This location causes no detrimental motions but offers no buoyancy before the fuselage is submerged. Tests have shown, however, that under some circumstances, a wing located at the bottom of the fuselage may have an adverse effect on hydrodynamic behavior. Flaps, nacelles, or the wing itself, may enter the water at high speeds, causing high decelerations or diving. These considerations lead to the conclusion that the safest position of the wing is slightly above the bottom of the fuselage in a low-mid-wing position.

Landing flaps have had a noticeable hydrodynamic effect on about 25 percent of the models tested. In a majority of these cases they caused a slight nose-down motion but in no case was a flaps-up condition advantageous. It is preferable to have flaps down in a ditching in order to obtain a low forward speed and so decrease the chances of fuselage damage but on low-wing airplanes the flaps should be weak enough to fail without producing an undesirable diving moment. A strength less than about 300 pounds per square foot appears satisfactory in this respect.

In general, the location of the tail surface has little effect on ditching. It has been found, however, that a low position of the horizontal tail surface can prevent excessive trimming-up where the fuselage has a shape that produces this motion.

Some recent transports have unusually large amounts of sweep-up on the after fuselage while others have high transverse curvature or perhaps a combination of both (fig. 10). A high degree of fuselage curvature causes a suction and the airplane will trim-up in the water. Trimming-up is not in itself detrimental but if it is great enough the airplane may leave the water and then reenter at an unfavorable attitude. Model tests have shown motions of this type in which the model trimmed-up so high that it stalled and fell back into the water out of control. Another disadvantage of trim-up is that if the suction breaks suddenly the airplane may trim down fast with the resulting impact causing damage.

Fuselages having moderately curved cross sections (fig. 10) appear to be as stable dynamically as those with nearly flat bottoms.

Since flat bottoms are subject to much higher bottom pressures and are structurally less efficient for carrying loads, it is advantageous to use moderately curved sections.

The strength of the bottom of the fuselage is probably the most important factor influencing ditching behavior. A majority of airplanes would ditch well if the fuselage bottom did not sustain large damage. In order to determine the effect of this damage models are tested with approximately scale-strength bottoms. Damage always occurs and sometimes produces undesirable motions and decelerations and of course the resultant water inflow is detrimental. If there are doors in the bottom they are usually weaker than the surrounding fuselage and so fail more easily with greater total resultant damage.

In general protuberances below the bottom of the airplane, by virtue of their water drag, tend to cause a detrimental diving moment. Exceptions to this occur when the protuberances are of such shape that they produce substantial hydrodynamic lift forward of the center of gravity or when the attachment is so weak that the protuberance tears off. Engines mounted low on a low wing or slung under the fuselage as on some recent jet airplanes (fig. 11), probably will not tear off and will be detrimental. It is best for engines to be well above the bottom of the fuselage if they are rigidly built in. However, when a strut is employed (fig. 11) the strut could be weak enough that the installation would tear off without causing trouble. This was true of the one model of this type that has been tested.

Fuel tanks (fig. 12) installed under the wing will have an effect similar to that described for engines except that tanks are not as rigidly attached and so tear off more easily. If a choice is available it is best to jettison such tanks. Tip tanks probably will not enter the water until a low speed is reached so will not cause undesirable behavior and will offer additional buoyancy if empty.

It is possible to obtain good ditching characteristics from even a very poor ditching airplane or to further improve the ditching characteristics of a good one by the addition of a ditching aid (fig. 13).

One method of preventing diving or nosing in during the high-speed part of a ditching run is the use of a hydroflap, a device near the nose that has sufficient hydrodynamic lift to furnish the required positive pitching moment. Of a variety tested, a narrow planing surface, having a trapezoidal plan form, and set at an incidence of about 30° to the fuselage was generally the most effective. The hydroflap offers an opportunity for keeping the nose out of

the water and reducing the loads on that part of the fuselage by concentrating on a small strong area the high water pressures present at landing speeds. Sometimes it may be possible to use a hatch or a speed brake to serve the additional function of a hydroflap with less additional weight than would otherwise be required. One type Navy airplane has employed a modified hatch as a hydroflap.

Another possibility for a ditching aid is a planing surface that can be extended on struts so that in landing the airplane rides on the planing surface with the main body of the airplane not subjected to high water loads at planing speeds. Almost any degree of effectiveness is possible with this device, depending on its size; and the hazardous motions and structural damage associated with ditching can be eliminated. For airplanes with solid bottoms such as transports a single planing surface retractable into the bottom would be suitable or twin surfaces retractable into the sides of the fuselage or into the wings could be used. The twin-surface arrangement would be most desirable if doors were required in the fuselage bottom.

In conclusion, it may be stated that the dynamic behavior and structural damage during ditching can greatly influence survival. The hazards involved can be reduced by proper selection of operational parameters during the approach and landing. They can be further reduced in the design stages of the airplane by proper consideration of features affecting behavior, ditching stations, and means of escape.

In general, safe ditchings could be accomplished if the fuselage bottom could be strong enough to withstand the water loads. An alternate and perhaps more feasible solution would be the use of ditching aids to keep the loads off the fuselage and control the motions during the high-speed part of the landing run.

0
3
2
3
2

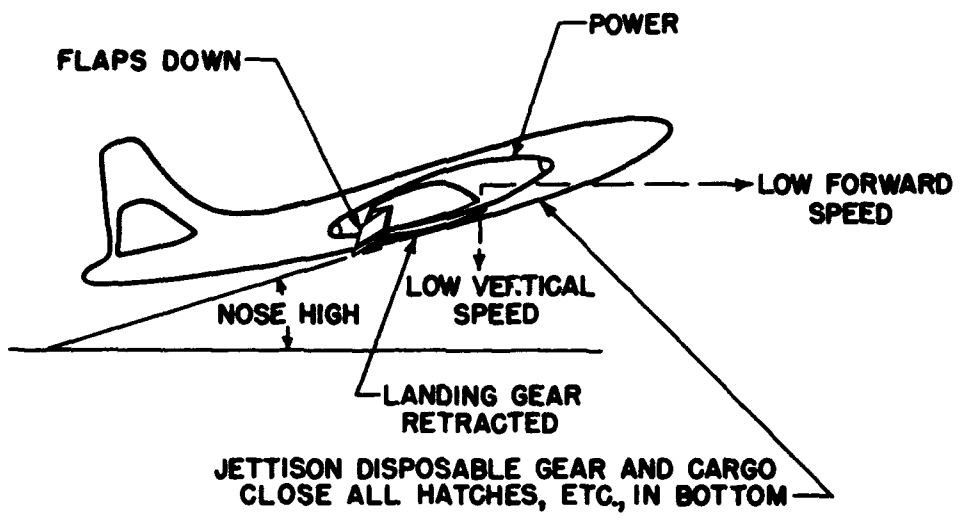

Figure 1. - Landing configuration.

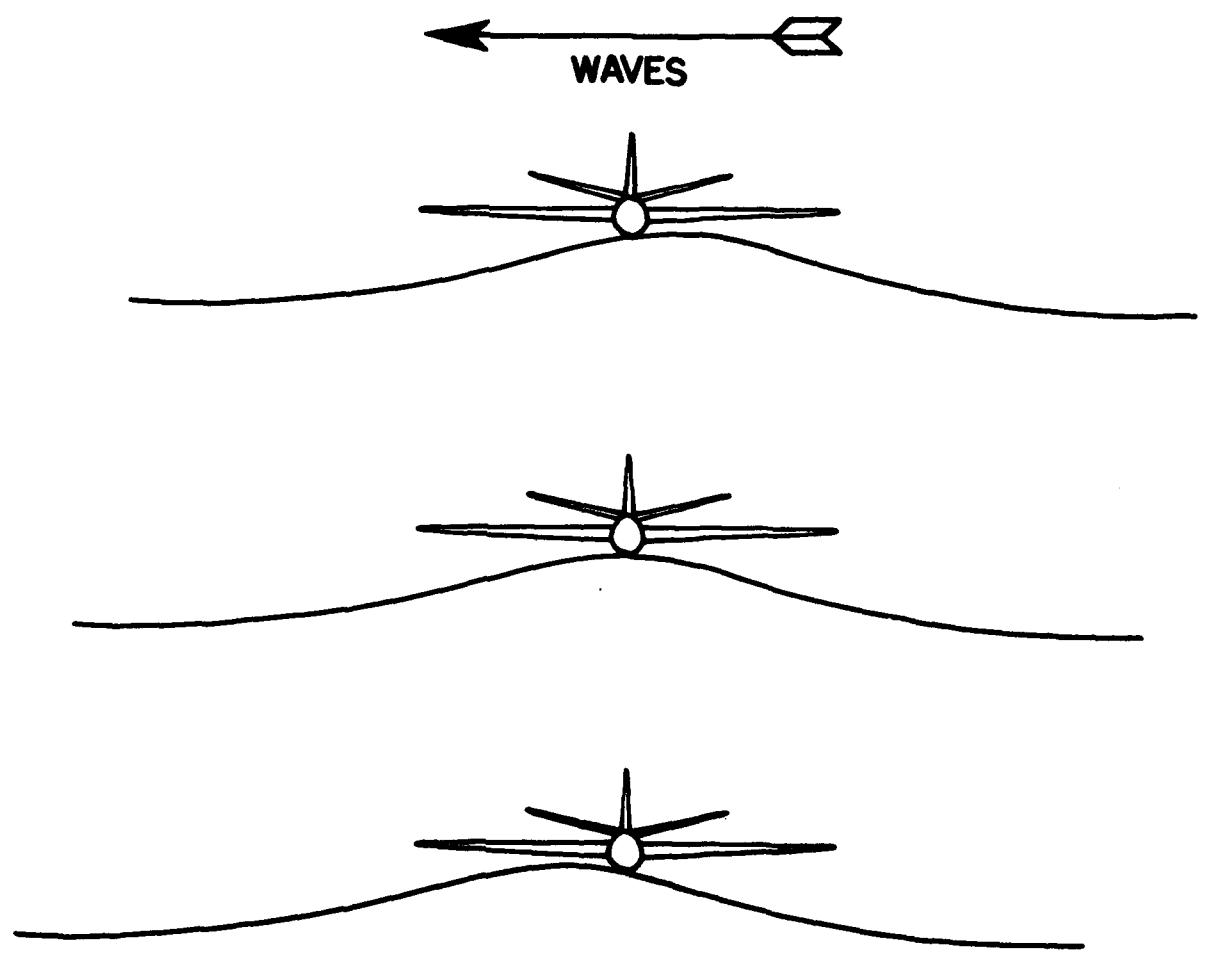

Figure 2. - Parallel waves (crest).

0
3
2
3
2

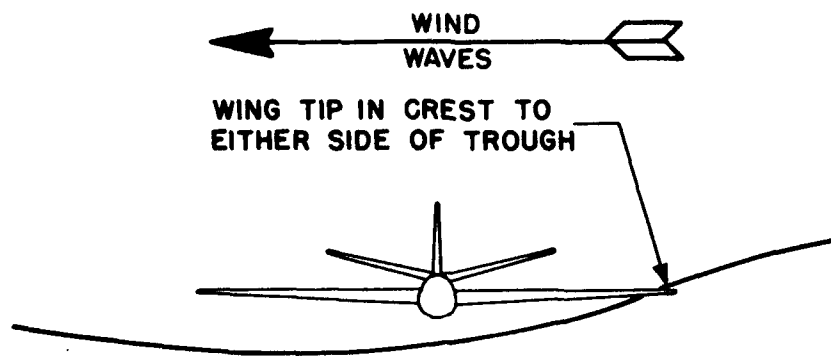

Figure 3. - Parallel waves (trough).

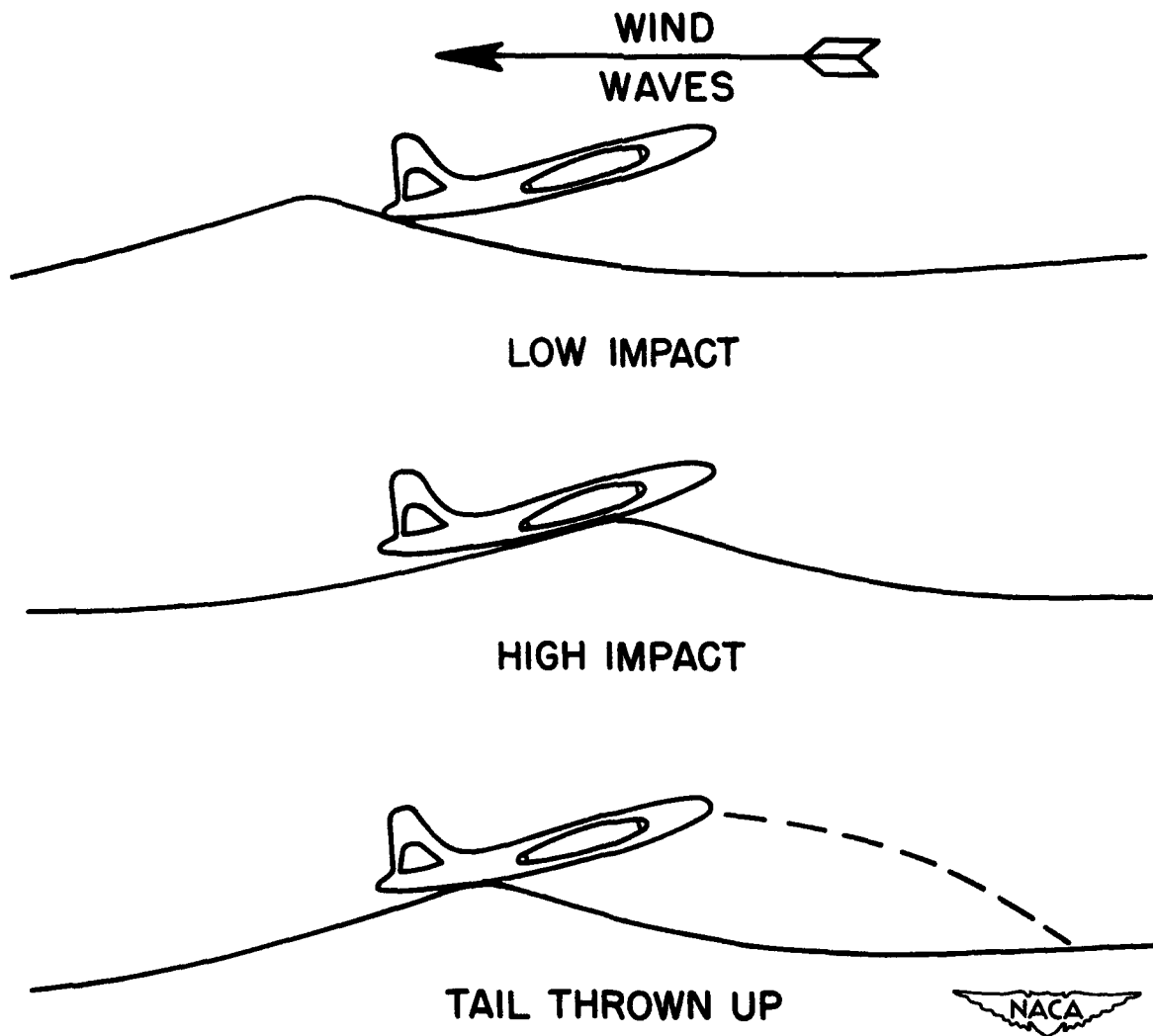

Figure 4. - Across waves.

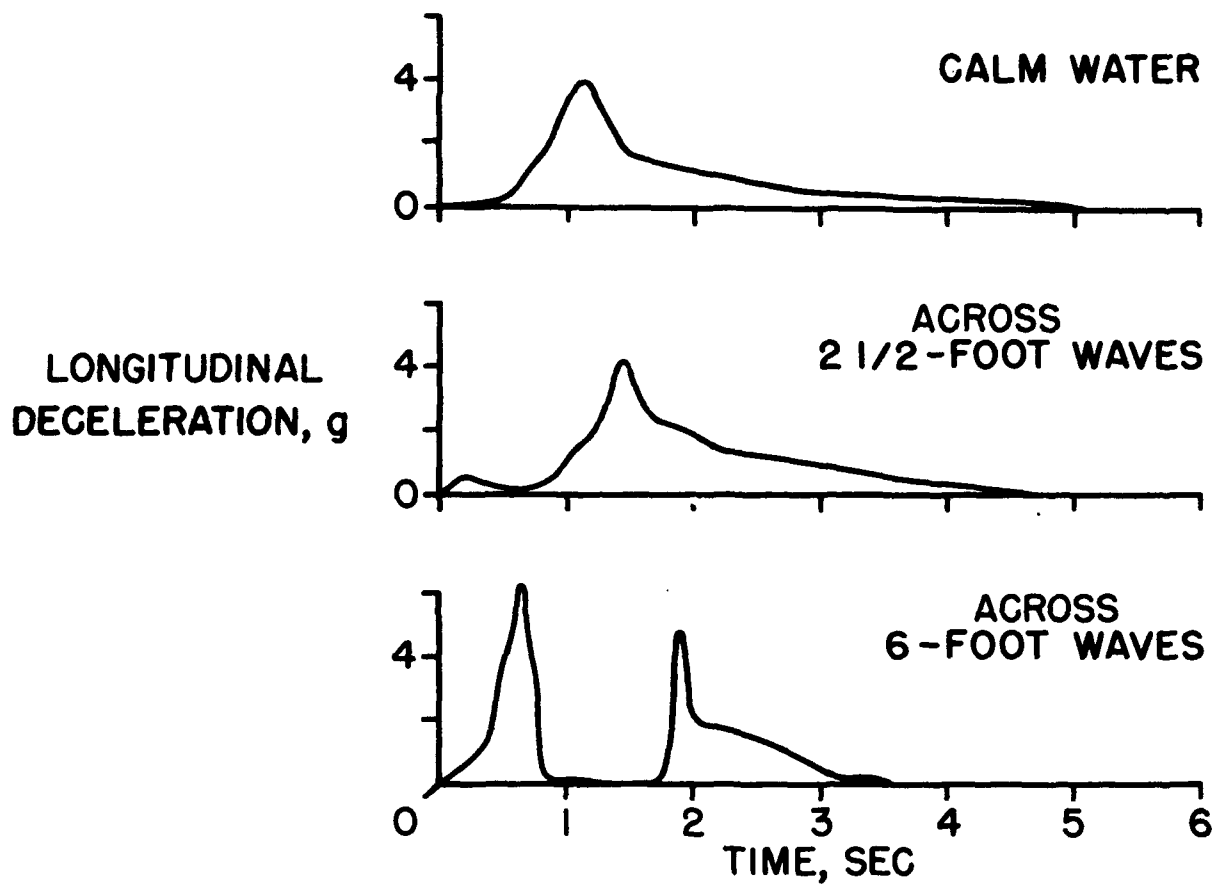

Figure 5. - Deceleration curves.

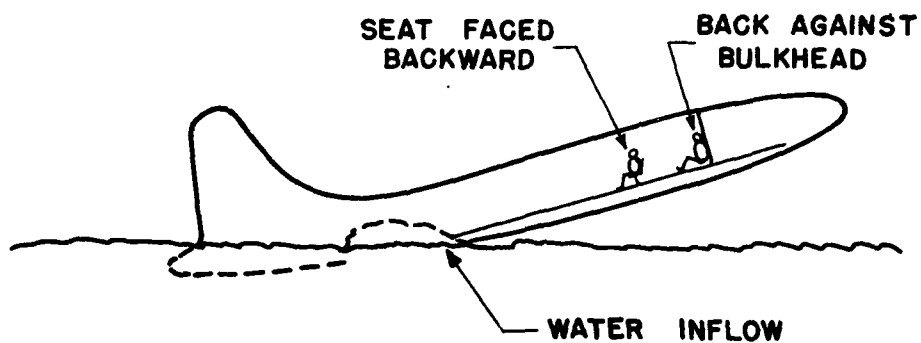

Figure 6. - Ditching stations.



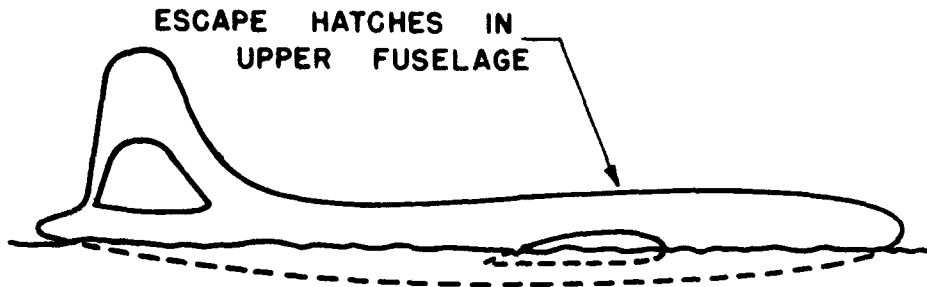

Figure 7. - Escape hatches.



WING

LANDING FLAPS

TAIL SURFACES

FUSELAGE SHAPE

FUSELAGE STRENGTH

PROTUBERANCES

Figure 8. - Design parameters.



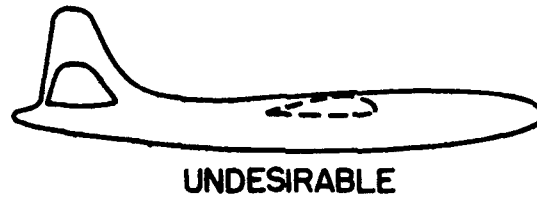
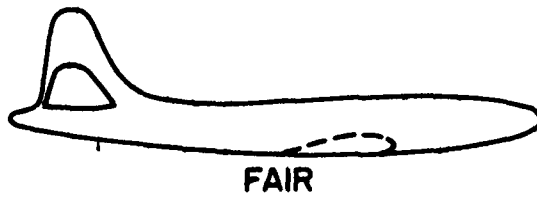
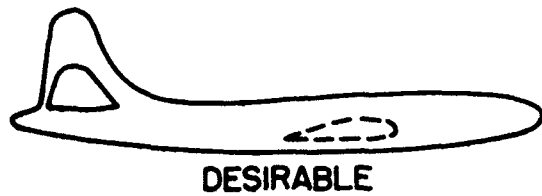

Figure 9. - Wing and fuselage combinations.

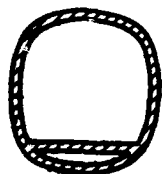
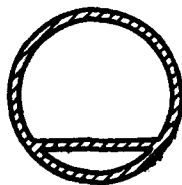
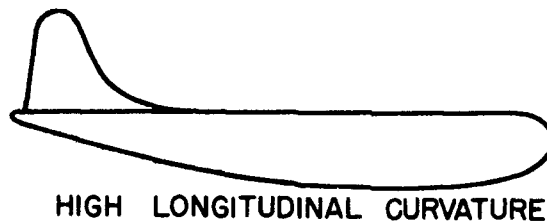
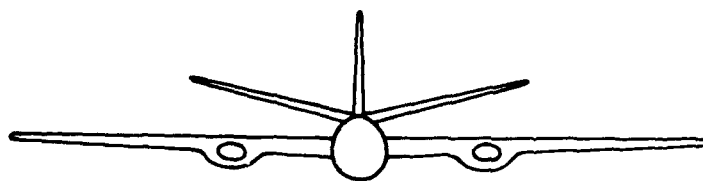
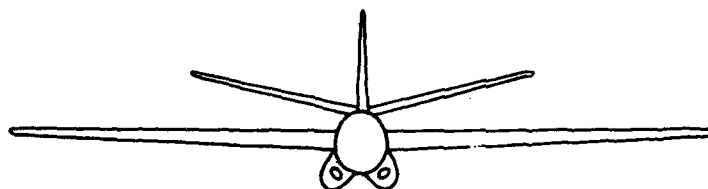

Figure 10. - Fuselage shapes.



ENGINES UNDER WING



ENGINES UNDER FUSELAGE

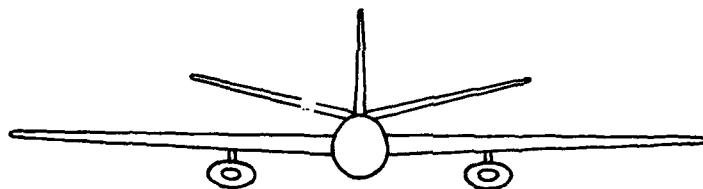

ENGINES ON STRUTS

Figure 11. - Engine arrangements.

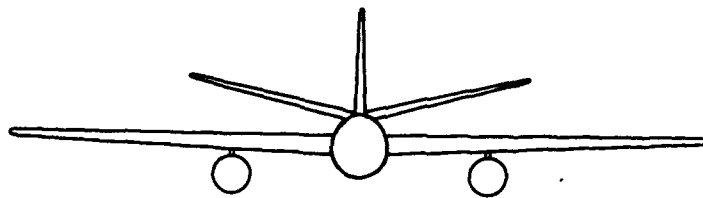

FUEL TANKS UNDER WINGS

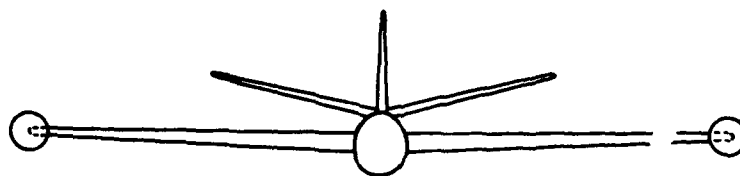

FUEL TANKS AT WING TIPS



Figure 12. - Fuel tank arrangements.

N
E
S
E

0

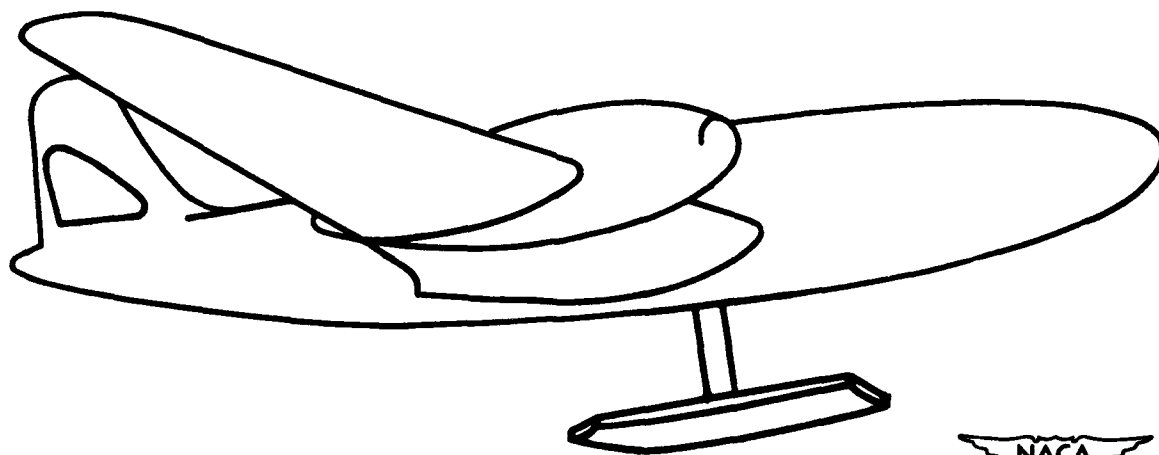
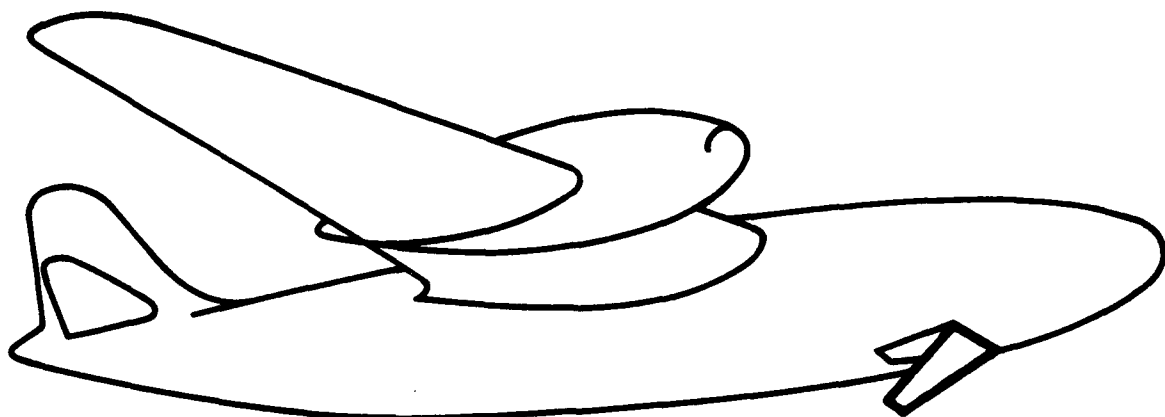

Figure 13. - Ditching aids.

10. SOME ASPECTS OF THE TRANSPORT AIRPLANE FIRE PROBLEM

By Irving Pinkel

SOME ASPECTS OF AIRCRAFT SAFETY - ICING, DITCHING, AND FIRE

SOME ASPECTS OF THE TRANSPORT AIRPLANE FIRE PROBLEM

10. By I. Irving Pinkel

Lewis Flight Propulsion Laboratory

Recent studies on the ability of humans to withstand high accelerations for short periods of time without injury have indicated that significant gains in airplane crash survival can be realized if fire following crash can be prevented. Acting on the recommendation of the NACA Operating Problems Committee and the Aircraft Fire Prevention Subcommittee, the Lewis laboratory of the NACA has engaged in a study of fires following take-off and landing crashes of survivable intensity. One phase of this work is the evaluation of the effectiveness of various ways the incidence and severity of the crash fire might be reduced.

This discussion of the crash-fire problem is by way of a progress report that will consider the knowledge of the mechanisms of crash fires gained from work already completed and the approach to the reduction of the crash-fire hazard indicated by the information obtained.

Preliminary to active experimentation, a study was made of the available information on past aircraft crash fires, reported in reference 1, which gives support to the following points regarding airplane crash fires.

1. Serious fires are associated with the large fuel spillage that results from a damaged fuel system.
2. Most of the suspected ignition sources are located at the nacelle.
3. Gases contained within the engine induction and exhaust system can serve as ignition sources.
4. The fuel is generally the first combustible to burn.

Because of the transitory nature of the conditions preceding a fire and destruction in the fire of the evidence on which to base an analysis of the physical circumstances associated with the fuel spillage and its ignition, a well-defined understanding of the crash-fire problem and an intelligent approach to its solution cannot arise from a study of crash accident records alone. Accordingly, a portion of the NACA program involves the study of actual crash fires conducted with twin-engine airplanes suitable for holding a complex, massive system of

instruments through a crash under simulated take-off conditions. The instruments provide:

1. A record of temperatures at selected stations within the nacelle, wings, and fuselage.
2. Detection of combustible vapors throughout the airplane.
3. Time and location of fuel line rupture.
4. Time and location of electrical short circuits.
5. Gas samples of cabin atmosphere.
6. The acceleration of the airplane in the crash.

A crash site (fig. 1) was developed to permit an airplane to accelerate from rest under its own power constrained by a guide rail to arrive at the crash barrier with take-off (or landing) speed. Details of the barrier are shown in figure 1 which shows the airplane runway and guide rail in the foreground. At the barrier, the rotating propellers strike the ground contained within the raised abutments, the landing gear is ripped free of the airplane by the same abutments, and the wing tanks are severed outboard of the nacelles by poles. After crash the airplane slides along the ground beyond the barrier. This arrangement provides a severe crash from the standpoint of fuel spillage and ignition source exposure.

In the conduct of these studies, it was appreciated that a considerable background of information exists on the ignition and burning of hydrocarbon fuels. It was our purpose to obtain an understanding of the factors introduced by the dynamics of the crash that control the ignition process and timing, and the subsequent rate of fire spread, and to establish on a firm factual basis those commonly considered ideas on crash fires which actually apply. The work completed thus far has provided information on the various ways fuel is released in a crash, a positive identification of several important types of ignition sources, details on the rate of spread of fire through fuel dispersed within and around the airplane, length of the pre-crash period that may elapse before fire occurs with different types of fuel spillage, the airplane decelerations associated with typical damage to the airplane structure, and the rate of development of lethal conditions within the cabin.

In these studies, it has been learned that fuel can be spilled from an airplane as an ignitable mixture of fuel vapor and air by

rupture of the engine induction system, as liquid from broken fuel lines and tanks, and as mist if the spillage occurs from an airplane in motion. In the last case, the aerodynamic forces on the fuel rip it to mist to form a highly flammable fuel aerosol that moves with the air around the airplane. A picture of such a fuel mist taken during an actual crash is shown in figure 2. The fuel beneath the wing appears as a dense cloud that increases in volume and decreases in density by admixture of additional air downstream of the wing.

Because of the significant role of this type of fuel spillage in the crash fires, it will be discussed in detail. First, an illustration (fig. 3) is given of the rapid development of the fire through the fuel mist. This demonstrates the fire propagated by atomization to mist of the fuel lost from an airplane whose wing fuel tanks have been exposed while the airplane was in motion. In the crash that produced this fire the pole barriers were arranged to smash the landing lights on the wing and tear open the tanks behind them. The ignition that occurred at the damaged landing light, as shown in figure 4, is evidence that a damaged electrical system can serve as an ignition source. The fire clearly originates at the location of the landing light before the airplane is displaced its own length from the pole barrier and the landing gear settled to earth.

Because of the close proximity of the ignition source to the spilled fuel, ignition was immediate. When an appreciable spanwise separation exists between the fuel source and the ignitor, a time delay is introduced in the ignition as illustrated in figure 5. This figure shows ignition by exhaust gases issuing from the engine stack at a point having a six-foot spanwise separation from the fuel-tank rupture approximately two seconds after fuel spillage, at a reduced airplane speed. Detailed studies of the ignition of fuels and lubricants on the exhaust-disposal system used in this airplane showed that the portion of the exhaust stack exposed to the air stream is not hot enough to ignite gasoline, but that the exhaust gases will do so readily. The two-second time delay between fuel spillage and ignition is of little consequence in the severity of the ensuing fire, but is of cardinal importance in the engineering of crash safety systems.

When the ignitor is located to one side and forward of the point of fuel spillage, an even greater delay occurs between the time of fuel-tank rupture and fuel ignition. As an example of this arrangement, fuel ignition from an oil fire burning in the nacelle well forward of the wing leading edge is presented in figure 6. The oil fire is visible through windows located on the nacelle cowling. In

this crash, the instrumentation indicated the oil fire to have started within 2 seconds of the crash. This picture was taken $4\frac{1}{2}$ seconds after the crash, at the moment of fuel ignition. Observe that the fuel mist lies well forward of the wing leading edge when the airplane comes to rest, which is the case in this figure.

Obviously, if the released fuel streaked rearward along with the air streaming by the narrow tank rupture, a physical separation between the fuel and ignition sources at the nacelle would be maintained and ignition could not occur. The tendency for the fuel to disperse spanwise (perpendicular to the air stream) is responsible for the contact between fuel and ignitor. A detailed study of this sidewise fuel spread conducted with taxiing airplanes and simulated fuel spillage shows the following mechanism of fuel dispersion. When fuel is lost from a decelerating airplane, the momentum of the fuel in the tank provides a forward surge and propels the fuel as a solid stream out of the tank rupture. Impact with the air spreads the stream to give a spanwise velocity component to the fuel particles somewhat as would occur if the solid stream of fuel were to splash against a wall normal to the original fuel direction. The forward velocity of the fuel is reduced with the acquisition of the spanwise kinetic energy and the advancing airplane intercepts the spreading fuel mist. If the airplane moves slowly, the fuel has an appreciable time to spread before such interception and can extend to the nacelle. Likewise, high airplane decelerations will produce high-velocity fuel jets that extend well ahead of the airplane and acquire high spanwise velocities. The combination of reduced airplane speed and high deceleration represents the critical conditions of airplane motion from the standpoint of ignition by a source located at the nacelle. This effect correlates the facts that ignition by the broken landing light adjacent to the tank rupture occurred immediately but ignition at the nacelle did not occur until the airplane had slowed appreciably from its high speed at crash. Wetting patterns produced on an airplane by the mist in the taxiing tests show these effects clearly (fig. 7). Typical fuel wetting patterns on the underside of the wing and nacelle are shown in this figure. Fuel spillage occurred from a tank rupture at this point. The wetting patterns obtained on the left correspond to fuel spillage from an airplane decelerating at 2.5 times the acceleration of gravity. The darker cross hatched surface corresponds to fuel spillage at approximately 56 miles per hour. In this case the wetting pattern does not extend to the exhaust stack, but at the reduced speed of approximately 25 miles per hour the wetting pattern does enclose the exhaust stack. At an airplane deceleration rate of 6.4 gravity, the airplane wetted area extends well past the exhaust stack at an airplane speed of approximately 60 miles per hour in contrast to the condition at

2.5 times the acceleration of gravity. The most extensive fuel wetting observed occurred at the reduced airplane speed of 35 miles per hour and the deceleration rate of 6.4 gravity.

Because the fuel is airborne in these mists, a cross wind from the wing tip to nacelle will displace the mist pattern toward the nacelle and increase the probability of fire. This applies to the case shown in figure 7, with the relative wind as indicated. If the wind were directly from the front, the wetting pattern would be symmetrical about the tank rupture. In this case, only a very extensive wetting pattern would reach to the nacelle.

Fuel spillage in the form of premixed fuel vapor and air can take place only from a torn engine induction system. The close proximity of ignition sources within the nacelle will cause ignition immediately after such spillage. Because of the small quantity of fuel in the induction system at any one time, however, no serious fire will result unless other fuel is ignited in the flash fire of the induction-system fuel. In one impact crash test the airplane was fitted with steel-bladed propellers. Impact of the steel propeller blades with the ground twisted the engine mounts and ripped the carburetor free from the engine induction system releasing the fuel vapor-air mixture into the nacelle. The fuel vapors were ignited by the hot exhaust collector rings. The explosive flash of the resulting fire ignited the fuel being lost from the tanks at the wing leading edge.

Fuel lost from a crashed airplane at rest is principally in liquid form as pools and rivulets. If a rivulet flows to an ignition source, or the fuel vapors are directed by moving air to an ignitor, the resulting fire propagates back to the primary pool of fuel. If fuel is still pouring from the damaged fuel system, the fire burns at the opening from which the fuel issues and tends to enlarge the initial opening. Crashes involving the spillage of fuel wholly as liquid have not been studied yet in sufficient detail for further discussion at this time.

The rate of fire spread through and around the airplane is complicated by many factors, chief among them being the ground and airplane area wetted by the spilled fuel, the wind direction, the local air ventilation in enclosed airplane cavities, and the vapor pressure of the fuel. Laboratory studies show the rate at which fire spreads over pools of quiescent fuel can be either several hundred feet per minute or just several feet per minute depending on whether or not the vapor pressure of the fuel is sufficient to maintain a combustible mixture in the air immediately above the pool of fuel. These figures are important in a crash only if the pool of fuel covers a significant

area around the airplane. If the fire begins before appreciable fuel has been exposed, the flame propagates to the opening from which the fuel is issuing, and ignites the fuel as it leaves. In this case, fire development is controlled by the rate of fuel efflux, with fuel vapor pressure playing only a secondary role. The rate of burning within an enclosed space such as a wing containing fuel is often controlled by the rate at which air circulation brings oxygen to the fire; fuel volatility is then of secondary importance. Fire spread along the exterior of the airplane follows the pattern of the ground fuel spillage and the zones of the airplane wetted by the fuel. Within a minute after ignition, the wetted skin of the airplane can be burned away. Magnesium engine parts will ignite in airplane fires and continue to burn after the surrounding fuel or oil fire is extinguished. The aluminum airplane parts will burn only when heated by an external source. Radiation will ignite paint on exposed surfaces at locations 20 feet from the perimeter of an intense fuel fire.

The discussion will proceed from a consideration of the separate events involved in a crash fire to a complete study of a full-scale crash. A fully instrumented airplane, carrying a take-off load of 1000 gallons of fuel and moving at a ground speed of approximately 80 miles per hour is involved in a crash that is quite severe from the standpoint of fuel spillage and exposure of ignition sources. A schematic view of the engine nacelle of this airplane (fig. 8(a)) shows the oil cooler located at the bottom of the nacelle immediately behind the exhaust collector ring. Following the usual airplane damage at the barrier the airborne plane hits the ground and slides. Impact of the nacelle with the ground breaks the oil cooler lines and the exhaust collector ring is wetted by the released oil (fig. 8(b)). Other oil spillage takes place from a broken nose gear housing. About two seconds after impact, the instrumentation indicates oil fire on the exhaust collector ring. Condensed oil vapors now issue from the nacelle. At the reduced airplane speed, the fuel mist extends forward of the leading edge of the wing. In four seconds (fig. 8(c)) the oil fire in the nacelle has grown to engulf the exhaust collector ring and provide an excellent torch for ignition of the fuel. When the fuel mist reaches forward to the oil fire in the nacelle as the airplane slows to rest, general inflammation of the fuel mist occurs with a high rate of spread (fig. 8(d)). Ten seconds after ignition, the fire has involved the wing and nacelle to the extent shown in figure 8(e). Fire within the wing is limited by the air flow through the wing rupture and covers a somewhat smaller area. After two minutes, the fire has the distribution shown in figure 8(f). The smaller solid area represents the fire after 10 seconds, and corresponds approximately to the original fuel spillage pattern.

After two and one-half minutes, the airplane cabin was completely gutted. Air temperatures within the cabin reached 300° F, considered the maximum survivable temperature, within 100 seconds of the crash, and analysis of the cabin atmosphere indicated a lethal concentration of carbon monoxide two minutes after crash.

A graph of the horizontal decelerations the airplane experienced in the crash and its slide to rest is shown in figure 9. The variation of airplane speed with displacement from the barrier is also shown. At the time the propeller hit the earth barrier, the whole airplane was subjected to an average deceleration of 3.5 g, but for too short a period of time to change the airplane speed appreciably. Severing the landing gear from the airplane caused a somewhat smaller deceleration of 3.2 g for a longer period. The highest deceleration of 4.0 g was associated with damage to the wing leading edge, main spar, and fuel tank by the pole barrier. The slide to rest occurs with approximately uniform deceleration of 1 g. From the standpoint of the accelerations imposed on the airplane, this type of crash would be survivable in the absence of the fire that followed it.

On the basis of experience to date, it appears that crash-fire safety systems for current airplane types using present fuels must aim at inhibiting the ignition process. Once the fire develops, extinguishment is highly improbable with the quantity of extinguishing agent likely to be carried in the airplane. The viewpoint has been taken that the ignition process is essentially a race between the declining potency of the several classes of ignition sources with time and the conduction of fuel in sufficient concentration to a source of ignition. Declining potency of an ignition source is illustrated in figure 10, which shows the rate of cooling of an exhaust collector ring from a temperature of 1200° F, corresponding to take-off power employed at the moment of a crash. It requires 50 seconds for the exhaust system to cool to 900° F, the lowest temperature at which gasoline will ignite and 200 seconds for the collector ring to cool to 600° F, the lowest temperature at which lubricating oil will ignite. A somewhat similar curve could be drawn for the temperature of a short-circuited wire drawing current from discharging storage batteries. From the crash studies it has been learned that the fuel or oil reaches the collector ring long before it has time to cool to a safe temperature.

With considerations such as this in mind, an indication of the possible approaches to reducing the crash fire hazard of current airplane types with present-day fuels will be made. Fuel ignition requires the coexistence in one environment of fuel, oxygen, and an ignition source. The prevention of fire involves the elimination of

one of these three factors at every zone. Fuel lines and tanks capable of withstanding the crash would provide complete fire protection by eliminating available fuel. Such fuel systems are not, however, currently available. Likewise, experience to date shows that an unacceptable weight of extinguishing agent would be required to inert the atmospheres around all ignition sources over the period that ignition is likely. Therefore, present efforts are directed toward reducing the number of ignition sources and inerting the atmosphere around those that cannot be eliminated. The effectiveness of this approach can be appraised by testing an installation similar to that shown schematically in figure 11.

This installation includes the following elements activated at the moment of crash.

a. A fuel cut-off valve aft of the carburetor to stop fuel flow and bring the engine to rest.

b. A two-pound charge of methyl bromide or other suitable fire extinguishing agent discharged into the induction system of the engine to inert the fuel-air mixture entrapped in the induction system when the fuel valve is closed. The extinguishing agent would also sweep through the engine to inert gases in the exhaust-disposal system as well. This would prevent backfires and the torching of flames from the exhaust stack.

c. An electrical system cut-off switch to prevent the development of arcs and short-circuited wires.

d. A simple spray system arranged around the exhaust-disposal system employing water or other suitable liquid to wet and cool the exhaust-disposal system. The heat capacity of the exhaust system is not large. Preliminary experiments indicate the possibility of cooling the exhaust system to safe temperatures with less than 4 gallons of water. The steam generated on the hot exhaust system would inert the immediate neighborhood and ignition would not occur while the exhaust-system temperature is being reduced.

Application of this system or any of its components to an actual airplane crash safety system would require a manual override for the pilot on the fuel valve and on the electrical-system switch. All such systems should provide that in normal airplane operation, the crash-sensitive element that actuates this system would be inoperative to prevent inadvertent functioning of the system. When the pilot believes a crash is imminent, the system can be alerted for the brief dangerous period with no loss in pilot control.

The question of the benefits to be derived from the use of fuels of low volatility, the so-called safety fuels, is not answered completely by the studies conducted so far. On the basis of laboratory experience to date, however, in which fuels having a wide range of volatility atomized to mist in jet-engine combustors have burned satisfactorily, it appears that in those crashes in which dense fuel mists are ignited by contact with a potent ignitor, little advantage would be gained by use of a fuel of low volatility. Experience with coal and other dust fires is consistent with this point of view. The formation of such dense fuel mists, while characteristic of the several crashes conducted, may prove to be a less significant factor in other types of crashes of survivable intensity.

The evaluation of the effect of airplane configuration and fuel-system design on fire after crash is also necessary. In this field, assistance is available from the work of the CAA and other agencies that are approaching the crash-fire problem with the point of view that if the fuel system can be made to remain intact during crash and prevent the spillage of fuel, no serious fire will occur. Future work on the significance of airplane configuration in the crash-fire problem should be directed with special emphasis toward configurations including turbopropeller and turbojet engines.

REFERENCE

1. Pesman, Gerard J.: Analysis of Multiengine Transport Fire Records. NACA RM E9J19, 1950.



NACA
C-148
9-29-49
A-118

Figure 1. - Scene showing crash barrier.

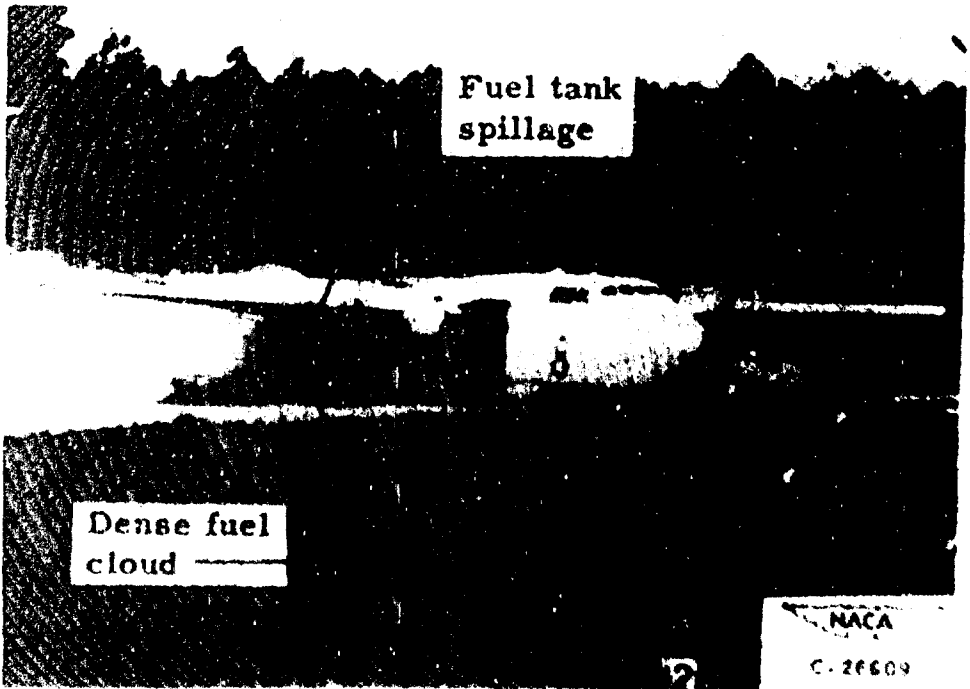

Figure 2. - Crash showing fuel mist below wing.



Figure 3. - Crash showing wall of fire at end of airplane skid.

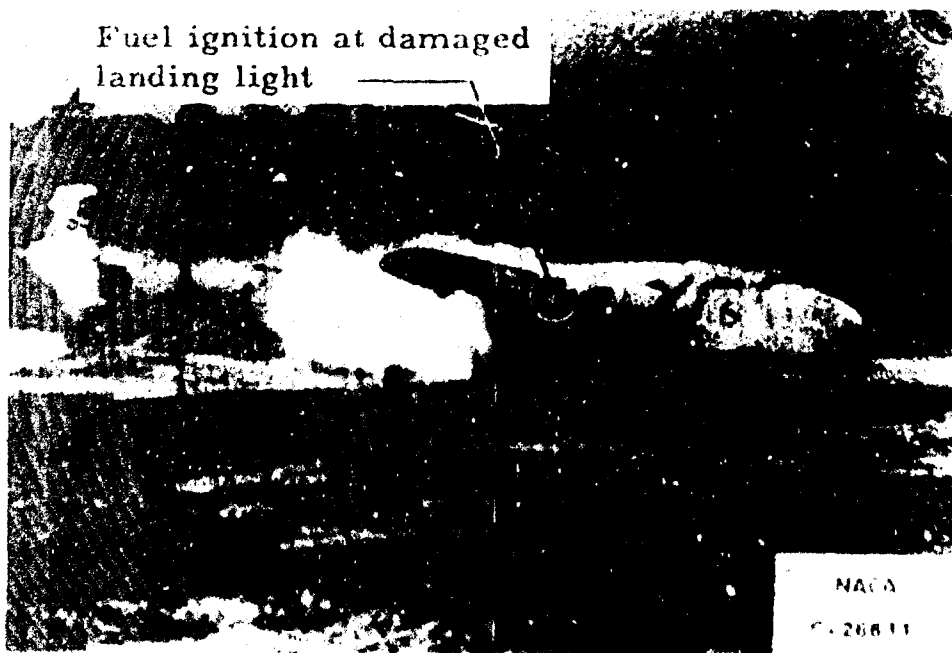

Figure 4. - Crash showing ignition at damaged landing light.

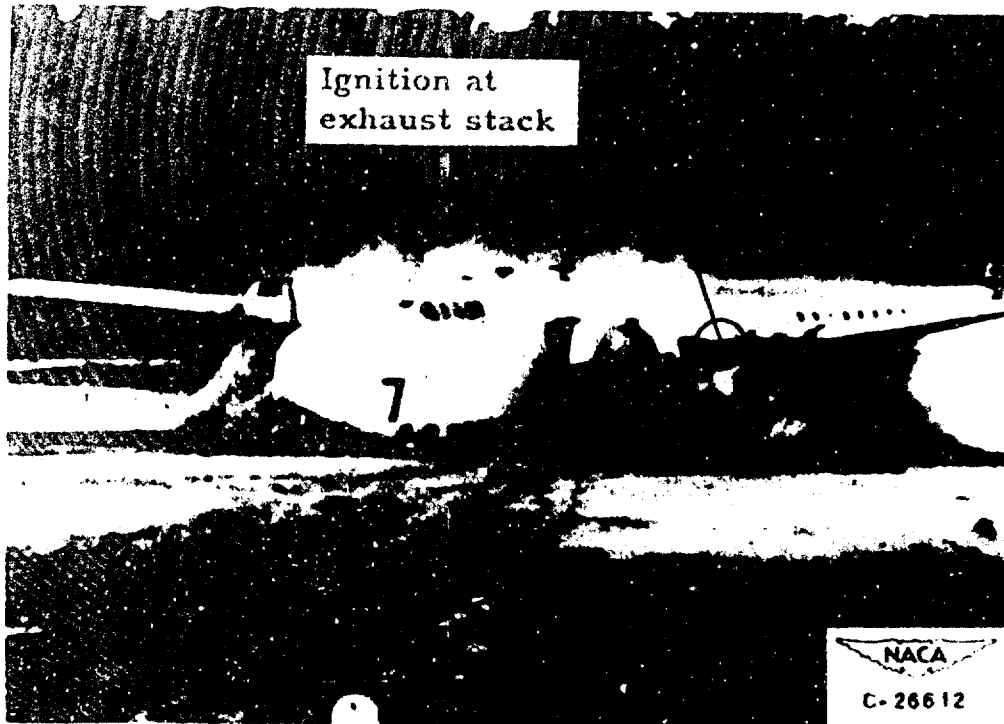

Figure 5. - Crash showing ignition of fuel at exhaust.

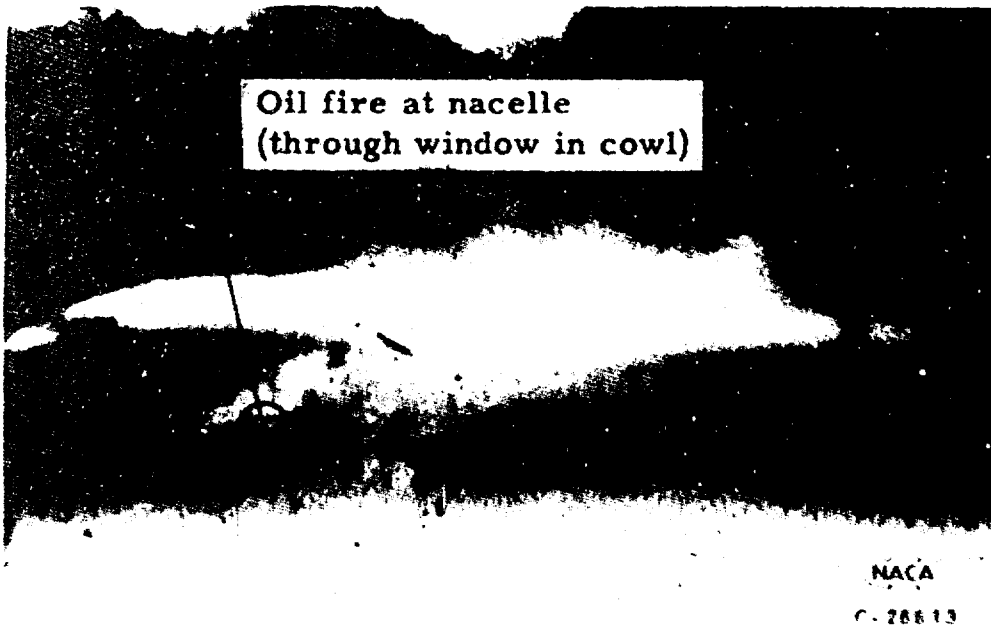

Figure 6. - Crash showing fire in nacelle.

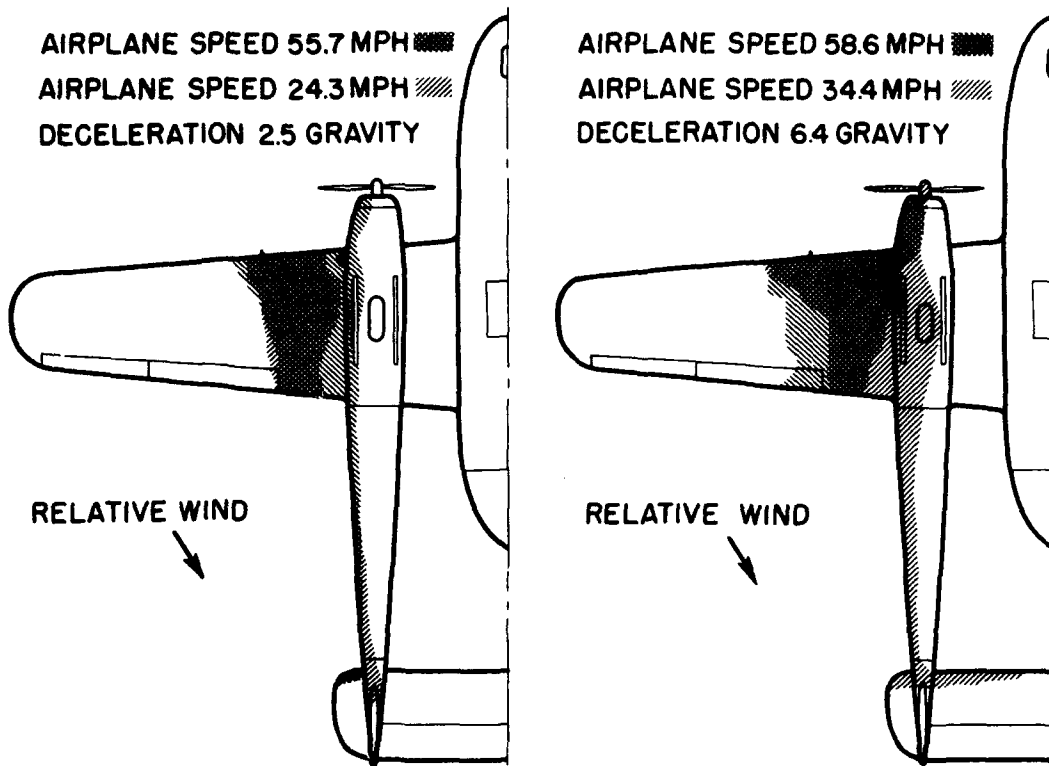
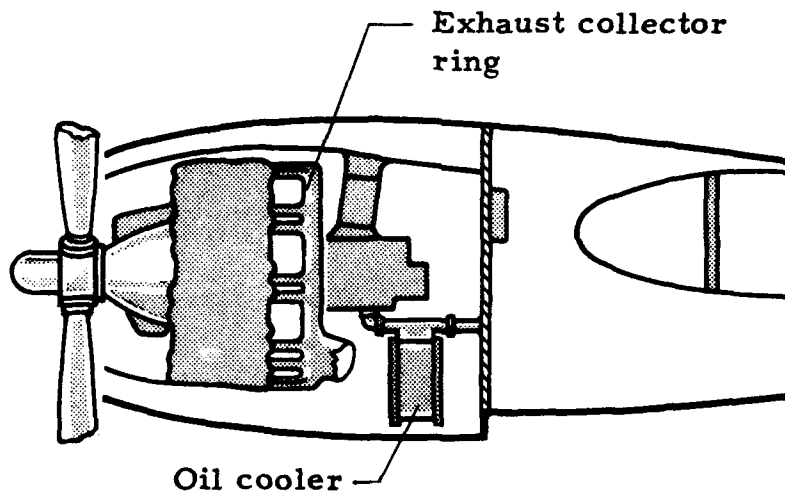

Figure 7. - Wetting patterns produced by mists.



NACA

C-26614

Figure 8(a). - Schematic view of engine nacelle.

0
7
3
5
2

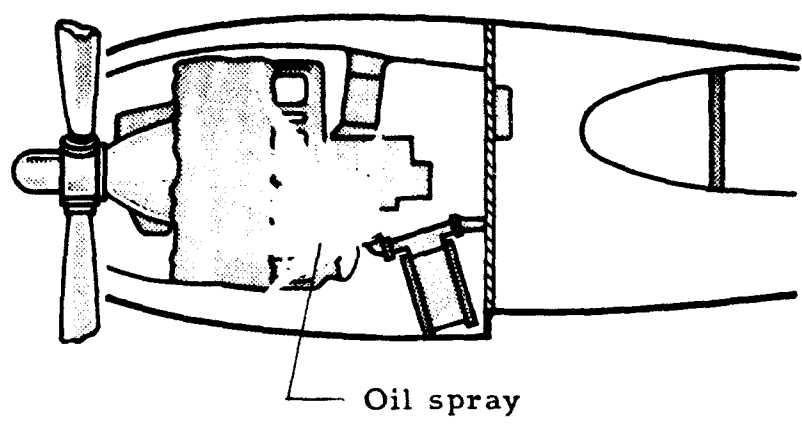

NACA
C-266 15

Figure 8(b). - Oil spraying in nacelle.

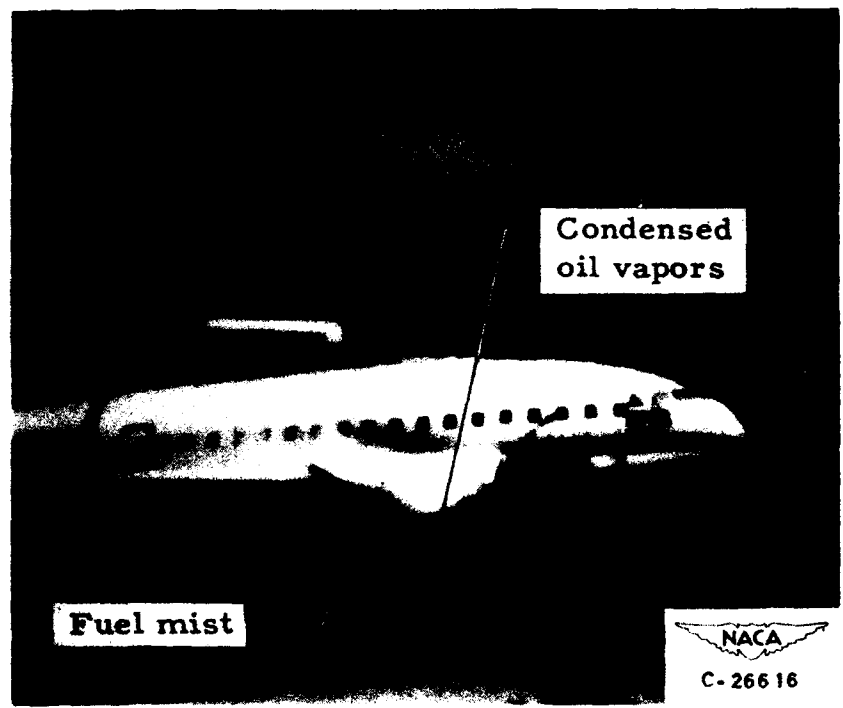

0
0

Figure 8(c). - Airplane sliding along ground with oil vapors pouring from nacelle.

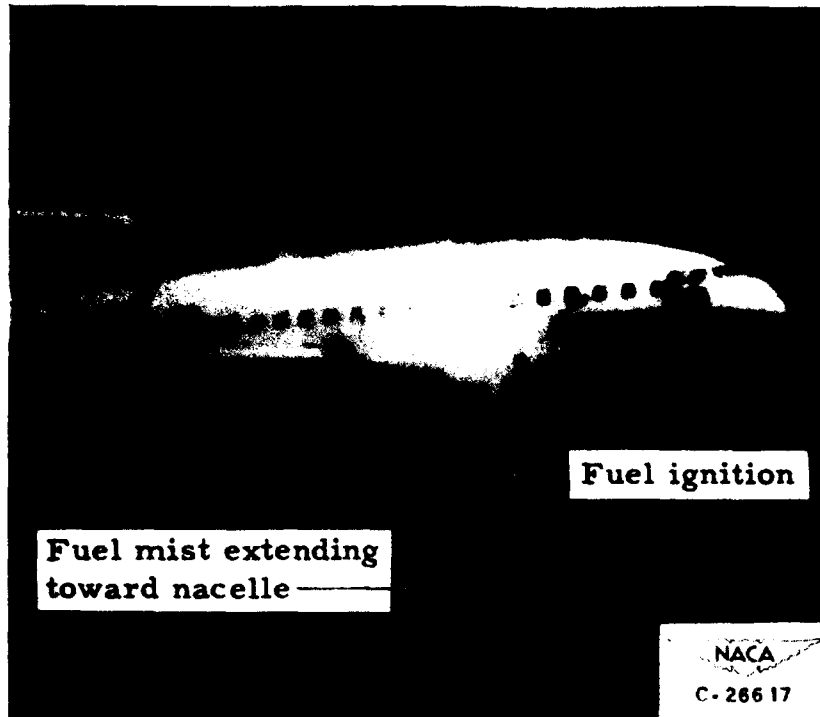

Figure 8(d). - Ignition of fuel in oil fire.

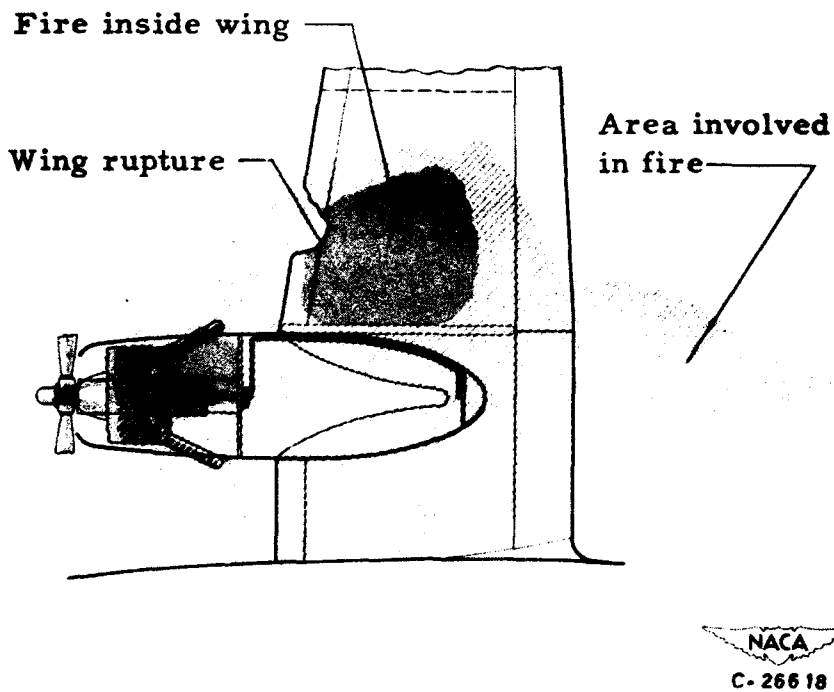
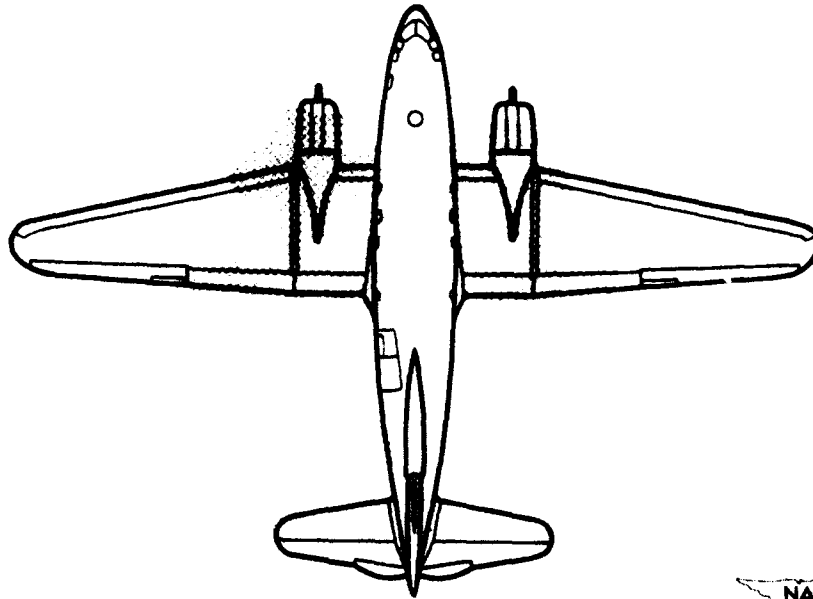

Figure 8(e). - Schematic view of area of airplane involved in fire after 10 seconds.

Dark area corresponds to
fire zone after 10 seconds



NACA
C-26619

Figure 8(f). - Schematic view of area of airplane involved in fire after 2 minutes.

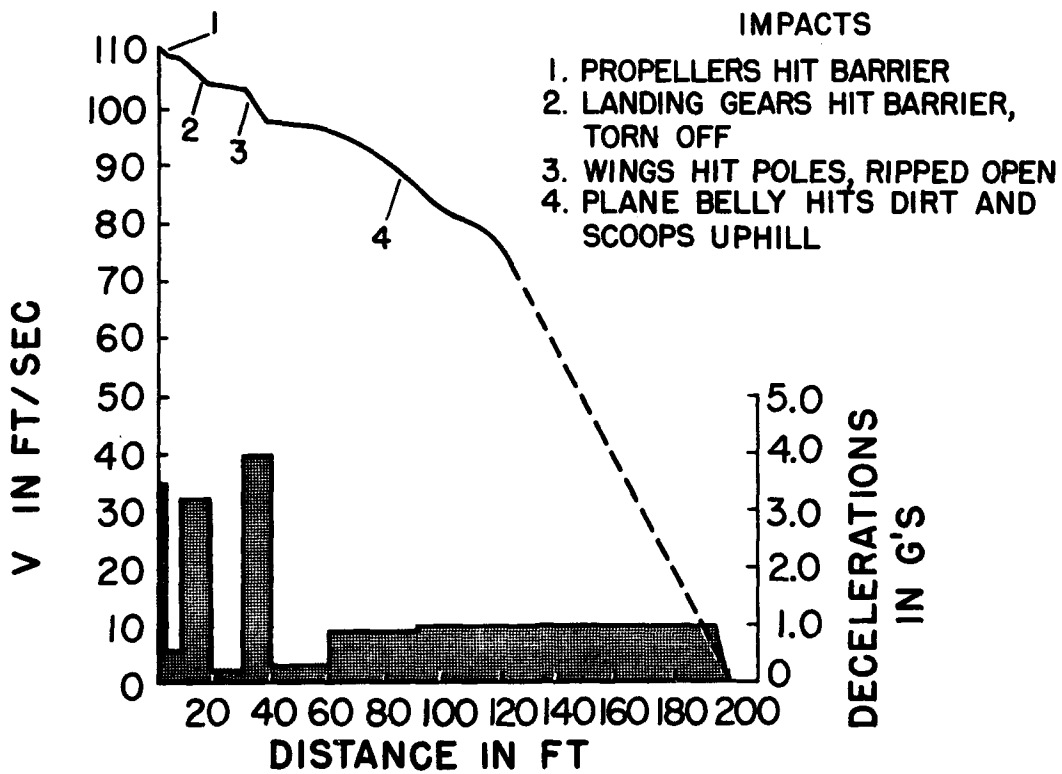

Figure 9. - Airplane velocities and decelerations.

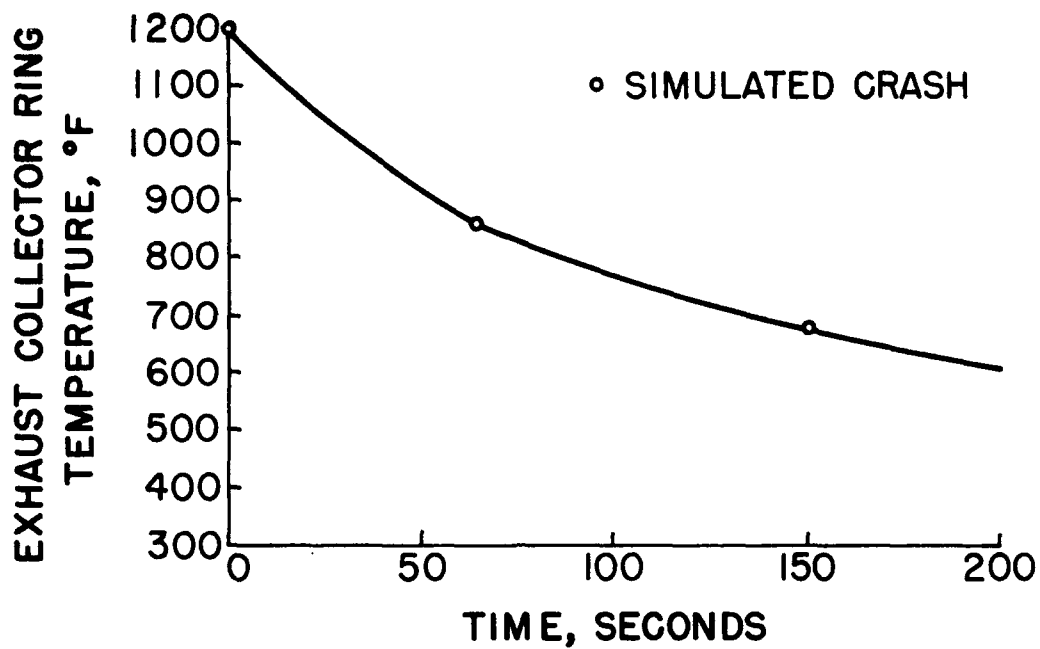

Figure 10. - Cooling curve for exhaust collector ring.

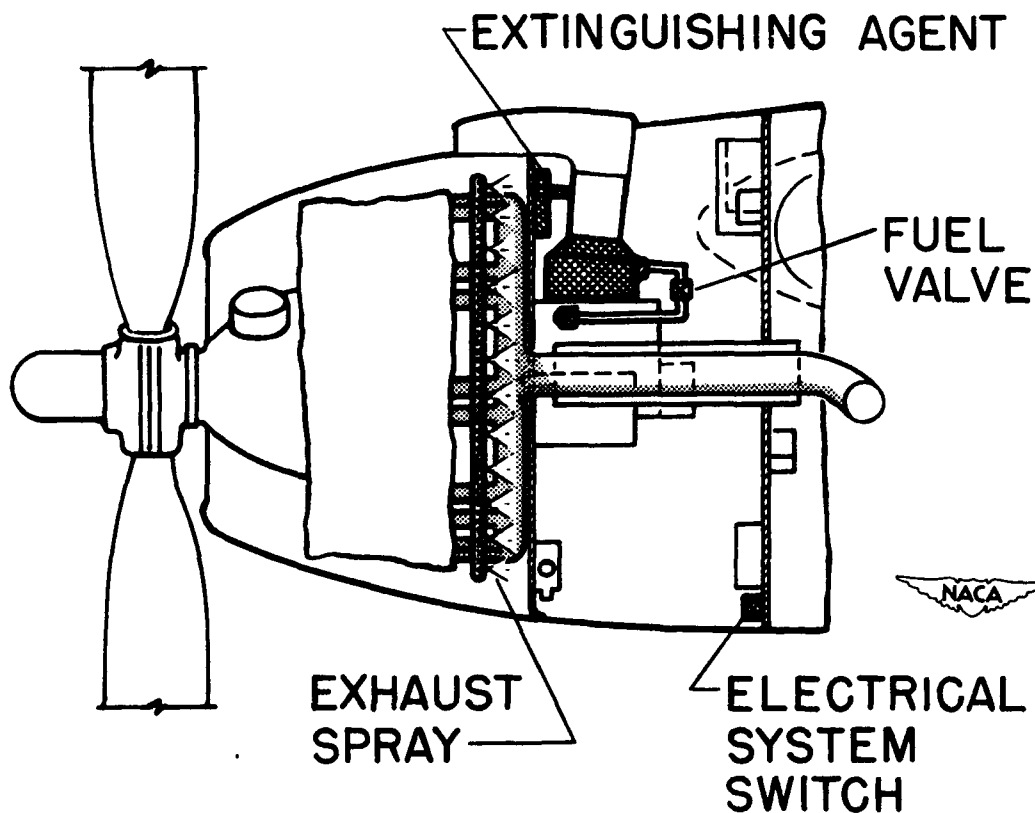

Figure 11. - Fire suppression installation.

RESTRICTED

AERODYNAMIC CONSIDERATIONS FOR HIGH-SPEED TRANSPORT AIRPLANES

RESTRICTED

11. REVIEW OF AIRPLANE CHARACTERISTICS PERTAINING TO
HIGH-SPEED PERFORMANCE

By Ralph P. Bielat

AERODYNAMIC CONSIDERATIONS FOR HIGH-SPEED TRANSPORT AIRPLANES

11. REVIEW OF AIRPLANE CHARACTERISTICS PERTAINING
TO HIGH-SPEED PERFORMANCE

By Ralph P. Bielat

Langley Aeronautical Laboratory

This paper reviews some of the aerodynamic factors that will enter into the design and operation of high-speed transports where the term "high-speed" refers to the higher subsonic speeds: perhaps 500 or 600 miles per hour.

Reference is made to a recent paper by Mr. Kartveli, of Republic Aviation Corporation, entitled "Propulsion Analysis for Long-Range-Transport Airplanes," (reference 1). In this paper Mr. Kartveli has taken the Republic Rainbow and broadly redesigned it, first, as a faster turbo-propeller version, and then as a still faster swept-wing turbo-jet version, and compared the performance of these three versions. The present paper reviews the aerodynamic considerations such as wing aerodynamic characteristics, nacelle characteristics, compressibility effects, aeroelasticity, etc. that would enter into the selection of configurations in the 500-to-600 mph class.

Some data obtained from reference 2 are presented for a present-day, four-engine transport airplane shown in the lower left corner of figure 1. The wing is 18 percent thick at the root and tapers to 12-percent thickness at the tip. The tail section is 13 percent thick at the root and 10 percent thick at the tip. The fuselage has a fineness ratio a little greater than 7.5. The airplane has the typical blunt-type nacelles. The design of these basic aerodynamic components of the transport are satisfactory and efficient for the speeds at which transports operate today, that is, in the range of 300 to 350 miles per hour.

Plotted in figure 2 is the variation of the drag coefficient and lift-to-drag ratio with Mach number for level flight at altitudes of 20,000 feet and 38,000 feet for the four-engine transport for a wing loading of 65 pounds per square foot. If this transport is flown at either of these altitudes, it can be seen that the drag decreases up to a Mach number of approximately 0.65, after which it rises markedly. This is the typical variation of drag coefficient for a given altitude as the airplane flies through its speed range. The reduction of drag coefficient with Mach number up to 0.65 is caused by the large reduction of the induced drag as a result of the decreasing lift coefficient

with speed for level flight. The portion of the curves showing the tremendous drag rise above a Mach number of 0.65 is due to the adverse effects of compressibility on the wing.

The range for a given pay-load or the pay-load for a given range depends upon the lift-to-drag ratio. Normally the transport cruises at a Mach number of 0.43 at approximately 23,000 feet altitude. For this condition, the transport is flying at approximately its maximum lift-to-drag ratio. If the airplane is flown faster at 23,000 feet altitude, it can be seen that the lift-to-drag ratio is falling off rapidly, but this is due to the fact that the transport is now flying at too low lift coefficients for maximum L/D. The higher lift coefficients corresponding to maximum L/D for the higher speeds occur at high altitudes where the air densities are lower. What can be done by flying at the higher altitudes can be seen by the data for 38,000 feet. For example, at a Mach number of 0.60, the L/D ratio of this transport can be increased approximately 56 percent when the altitude is increased from 20,000 feet to 38,000 feet.

Here we can see how the modern power plant, where the term "modern" refers to the turbo-engine, fits naturally into the operation at higher altitudes. First, the turbo-engine, when compared with the piston engine, has the necessary extra power which is needed to fly at faster speeds. Second, its efficiency is best at the high altitudes and high speeds where the airplane is also aerodynamically efficient.

Out in the speed range above Mach number 0.65 (fig. 2) the L/D ratio is decreasing rapidly which is caused by the large increases in drag. Associated with these adverse compressibility effects there would be the large power requirements needed to operate this transport above Mach number 0.65, and also turbulent separation of the flow due to shock formations on the wing would result in severe buffeting adding to passenger discomfort and danger to the airplane structure. Another limitation on the speed is the deterioration of the lift and pitching-moment coefficients of the airplane.

Shown in figure 3 is the variation of lift coefficient with angle of attack for a series of Mach numbers. It can be seen that, for a Mach number of 0.5, the lift exhibits no unusual characteristics for the range of angle of attack shown. At a Mach number of 0.65, it breaks over sharply at about a lift coefficient of 0.60. This value is above the level-flight lift coefficient which in general will be of the order of 0.3 or 0.4 but, of course, this does not leave much margin for maneuvering. At Mach numbers of 0.7 and 0.75, it can be seen that the lift coefficient has dropped abruptly.

Also shown on figure 3 is the variation of pitching-moment coefficient with lift coefficient for the same series of Mach numbers. Up to a Mach number of 0.65 and a lift coefficient of 0.6, the changes in pitching moment for the transport are not too severe. At Mach numbers of 0.70 and 0.75, strong breaks in the pitching-moment curves appear. The breaks in the pitching-moment curves appear as large negative or diving moments. These changes in pitching-moment and lift curves are such that the elevators may be incapable of controlling the attitude of the airplane at these speeds.

If transports are to operate efficiently and safely at the higher speeds, that is, 500 to 600 miles per hour, we must consider what modifications must be introduced to avoid these difficulties. The wing is here considered first, since the wing is the major source of the drag rise of present airplane configurations. As was stated above, the wing on this airplane is 18 percent thick at the root and tapers to 12-percent thickness at the tip, and its drag went up at a Mach number of 0.65. If it is desired to fly faster than a Mach number of 0.65, or 430 miles per hour, the wing will have to be made thinner. The transport shown in the middle of figure 1 is basically similar to the present-day, four-engine transport shown at the bottom of the chart except that the wing thickness ratio has been greatly reduced. Also, the blunt-type nacelles of this transport have been replaced with long, tapered nacelles. The reason for this is discussed below. Figure 4 shows the increase in the Mach number of the drag rise that can be obtained with unswept wings by using thinner wing sections (reference 3). The Mach number for the drag rise is defined as the Mach number where the drag first begins to increase markedly. The ordinate is the Mach number of the drag rise and the abscissa is the wing-thickness-chord ratio. It will be seen for the lift coefficients shown that the Mach number of the drag rise increases by approximately 0.015 or about 10 miles per hour for each one-percent reduction in wing-thickness ratio. If the wing-thickness ratio is reduced to 10 percent, the flight Mach number can be increased from 0.65 to approximately 0.73 at a lift coefficient of 0.3. This thickness ratio is about as low as it would be practical to go since fuel-storage space is required. However, thinner wings might be used with external tanks if necessary; but a weight penalty would have to be taken for these thin wings if the structural strength is to be maintained. The reduced wing thickness would introduce a trend towards increased wing-chord and in reduced wing aspect ratio with a corresponding reduction in aerodynamic efficiency.

Wing camber leads to further increases in the Mach number for the drag rise although the effect is much smaller than the effect of wing-thickness ratio (reference 4). If the airplane has to have satisfactory flight characteristics appreciably beyond its design operating speed, the amount of camber to be used should be restricted because the

longitudinal-stability problems that were previously noted are aggravated by camber.

Thus, a Mach number of about 0.73, or 480 to 500 mph is about the limiting flight speed that can be obtained by decreasing the wing-thickness ratio and introducing camber for unswept wings.

In order to fly at Mach numbers above about 0.73, the wing must be swept. The transports shown in the upper right corner of figure 1 represent two versions of future-day transports; the upper transport is a turbo-prop version and the lower transport represents a turbo-jet version. The wings and tail surfaces have been swept back approximately 35° . The conventional fuselage is replaced with one having increased fineness ratio and a rather sharp pointed nose. The nacelles are the long tapered nacelles. The reasons for these aerodynamic changes are discussed below. What can be accomplished with sweep is indicated in figure 5. Shown here are some data for the same wing which has been sweptback from 0° to 30° and 45° by rotating it about the root. Thus the wing section measured perpendicular to the leading edge remained unchanged. The data plotted in figure 5 show the variation of maximum L/D with Mach number. As stated above, the drag begins to increase above a Mach number of 0.70 and the lift-to-drag ratio decreases correspondingly. Sweeping the wing to 30° delays the L/D decrease to a Mach number of 0.82. At 45° sweepback the lift-to-drag ratio starts to decrease at approximately 0.90 Mach number. The improved characteristics in L/D for the sweptback wings at the high Mach numbers are the principal reason for employing sweep on these transports shown on the chart. In order to realize the full advantages of sweep, the wing thickness should be kept low.

Besides improving the lift-to-drag ratio characteristics, the use of sweep also reduces the adverse effect of compressibility on the stability-and-control and buffeting problems at high speeds.

There are a number of disadvantages associated with the use of wing sweep. One limitation on the use of sweep is its inherently high landing speed resulting from the fact that the sweptback wing stalls at a much lower lift coefficient than does a straight wing. The problem of getting satisfactory landing characteristics is further aggravated for the swept wings by the instability that develops at high lift coefficients. The elimination of such instability requires a trend toward lower aspect ratio which of course will reduce the aerodynamic efficiency. Some low-speed characteristics of thin-wing and swept-wing configurations are discussed in a subsequent paper (Part 12).

In addition to the maximum lift instability problems, there is at least one other limitation on the use of swept wings. This is the effect of the air forces in distorting the wing and thereby affecting its aerodynamic characteristics. The wing lift raises the tips and, since the bending is approximately through the line normal to the wing axis, a distortion results, and a large effective reduction in angle of attack occurs at the tips. This reduces the lift at the tip, and the center of load usually called the aerodynamic center, moves inboard and therefore forward. The effect is proportional to the dynamic pressure and is affected by both speed and altitude. Illustrated in figure 7 is the aerodynamic-center shift for a typical high-aspect-ratio swept wing. The figure shows the variation of the forward aerodynamic center shift in percent of the mean aerodynamic chord with flight speed for sea level, 20,000 feet, and 40,000 feet altitudes. At 20,000 feet and 500 mph the forward aerodynamic shift amounts to 13 percent of the mean aerodynamic chord and at 40,000 feet the forward aerodynamic-center shift is only 6 percent. Thus, it can be seen that high-speed flight is quite limited to the high altitudes if the aerodynamic-center shift is to be kept within reasonable limits, unless the structural weight of the wing is greatly increased. Other static aeroelastic effects that are troublesome at high dynamic pressures are those due to aileron deflection. The rearward center of lift due to aileron deflection tends to twist the wing, reducing its angle of attack. This effect is aggravated by the previously mentioned effect, since the aileron lift at the wing tip tends to raise it and results in the effective reduction in angle. The wing will thus have to be very rigid and some compromise with aspect ratio will be required to keep the lateral control from actually reversing itself at the high dynamic pressure. The aeroelastic problems discussed which make the design problem somewhat difficult pertain only to the wing. It should be mentioned that there are aerodynamic factors other than the wing that enter into the design; however, reasonable solutions to some of these problems have been obtained for the speed range considered here.

Another aeroelastic effect is the simple wing divergence which is of importance only for the unswept wing. Since the center of lift is ahead of the torsion axis, the lift increases the angle of attack and, if the dynamic pressure is very high, the wing will have to be very rigid if it is not to fail by simple twist divergence. The reason for discussing these aeroelastic effects is the fact that the reduction of these effects will lead to a trend towards reduced aspect ratio which is undesirable from an aerodynamic viewpoint, and further emphasizes the need for flying at high altitudes.

This discussion has been concerned with the delay and reduction of the adverse compressibility effects on wings. Components of the airplane other than the wing may well become the critical factor in determining

the limiting normal operating speed of the airplane.

Figure 8 shows the variation of the drag coefficient based on body frontal area with Mach number of several streamline bodies of revolution, which for all practical purposes can be considered as fuselages or nacelles. The data were obtained from rocket-powered models and, hence, the tail surfaces on the models were necessary in order to obtain stability in flight. The bodies have fineness ratio of 6.0 and 9.0 and differ only in the location of the maximum diameter. By increasing the fineness ratio from 6.0 to 9.0 with the maximum body diameter located at 20 percent of the fuselage length, the Mach number for the drag rise can be increased from 0.82 to 0.88. If the position of the maximum diameter is moved rearward as shown by the bodies in the lower portion of the figure, the Mach number for the drag rise can be increased to approximately 0.95. The relatively high values of the Mach numbers for the drag rise for these streamline bodies of revolution are due to the three-dimensional type of flow over the bodies. It can be concluded that fuselage shapes can be designed which will operate efficiently at high speeds.

Flying-boat hulls can be considered in connection with the subject of fuselages. The shape of the flying-boat hull is not necessarily inconsistent with high-speed flight. The high fineness ratios, or high length-beam ratios, that have been found very advantageous for flying-boat hulls, are precisely what have just been concluded as being helpful for high speeds (references 5 and 6).

With regard to nacelles which come in all shapes and sizes, the problem is basically similar to that for fuselages, except that there tends to be an especially critical problem with respect to the wing-nacelle interference (references 7, 8, and 9). In the case of the fuselage, or the outboard side of the nacelle, figure 9, there is fortunately a favorable pressure gradient along the intersection, which tends to prevent flow separation in this region. On the inboard side of the nacelle, there is an unfavorable pressure gradient which tends to spoil the flow in that region. Careful design may alleviate this difficulty, but there remains the fact that the combined velocity increments due to the wing and the nacelle tend to reduce the drag-rise Mach number, especially along the joint of the inboard side. It is important that the combination be arranged so that the regions of highest velocity on the wing and nacelle separately do not fall together in the combination.

There does not seem to be much basic aerodynamic difference between a mid-wing and a low-wing nacelle from an interference standpoint, but the low-wing nacelle involves least interference with the wing structure

and also helps to stow landing gear.

Suspending the nacelle from a pylon is also feasible, but the pylon must be sufficiently long. A short pylon results in local crowding in the region between the nacelle and the wing, with low-drag-rise Mach numbers and likely buffeting. With the long pylon, the forward or rearward position of the nacelle is preferable, and also the pylon needs to be swept about 30° or more if the highest drag-break Mach number for the arrangement is desired.

The air inlets on these nacelles offer no special difficulty in the speed range that has been considered as is indicated by the external drag characteristics of the two lower inlets in figure 10. The blunt cowlings that have been used over the engines for the past numbers of years will be replaced with the longer-tapered inlets in order to avoid high local velocities right at the cowling lip. Where the design requires a side inlet, the problem becomes somewhat more complex; but reasonable solutions for these inlets have been obtained for the speed range that has been discussed.

To conclude, a rather broad discussion of some information which is applicable to the design of transports to operate efficiently aerodynamically and safely in the speed range of 500 to 600 miles per hour has been given. In order for the transport to operate in the speed range of 500 to 600 miles per hour the wing thickness ratio was reduced to 10 percent and the wing was swept back as shown in figure 1. In addition, the fineness ratio of the fuselage was increased the position of maximum diameter was moved rearward, and a rather sharp nose shape was used. Also, the rather large-diameter, blunt-type nacelle was replaced with a smaller-diameter, long, tapered nose inlet. Some discussion of the aeroelastic problems which occur to make the design problem somewhat difficult was also given. There are other factors such as the pertinent engine and propeller characteristics, choice of power plant, that is, the turbo-prop or the turbo-jet, etc., that enter into the feasibility of flying at high speeds. But, essentially the aerodynamic factors which were discussed determine to a great extent whether this transport will operate efficiently and economically.

REFERENCES

1. Kartveli, Alexander: Propulsion Analysis for Long-Range Transport Airplanes. Aero. Eng. Rev., vol. 9, no. 6, June 1950, pp. 12-15, 69.

2. Hamilton, William T.: High-Speed Wind-Tunnel Tests of a 1/14-Scale Model of a Four-Engine Cargo Airplane. NACA MR, Feb. 1943.
3. Van Dyke, Milton D., and Wibbert, Gordon A.: High-Speed Aerodynamic Characteristics of 12 Thin NACA 6-Series Airfoils. NACA MR A5F27, 1945.
4. Summers, James L., and Treon, Stuart L.: The Effects of Amount and Type of Camber on the Variation with Mach Number of the Aerodynamic Characteristics of a 10-Percent-Thick NACA 64A-Series Airfoil Section. NACA TN 2096, 1950.
5. Riebe, John M., and Naeseth, Rodger L.: Effect of Aerodynamic Refinement on the Aerodynamic Characteristics of a Flying-Boat Hull. NACA TN 1307, 1947.
6. Riebe, John M., and Naeseth, Rodger L.: High-Speed Wind-Tunnel Investigation of a Flying-Boat Hull with High Length-Beam Ratio. NACA RM L7K28, 1948.
7. McLellan, Charles H., and Cangelosi, John I.: Effect of Nacelle Position on Wing Nacelle Interference. NACA TN (to be pub.).
8. Dannenberg, Robert E.: The Development of Jet-Engine Nacelles for a High-Speed Bomber Design. NACA RM A7D10, 1947.
9. Hieser, Gerald, and Whitcomb, Charles F.: Investigation of the Effects of a Nacelle on the Aerodynamic Characteristics of a Swept Wing and the Effects of Sweep on a Wing Alone. NACA TN 1709, 1948.



Figure 1. - Comparison of present day and future day transports.

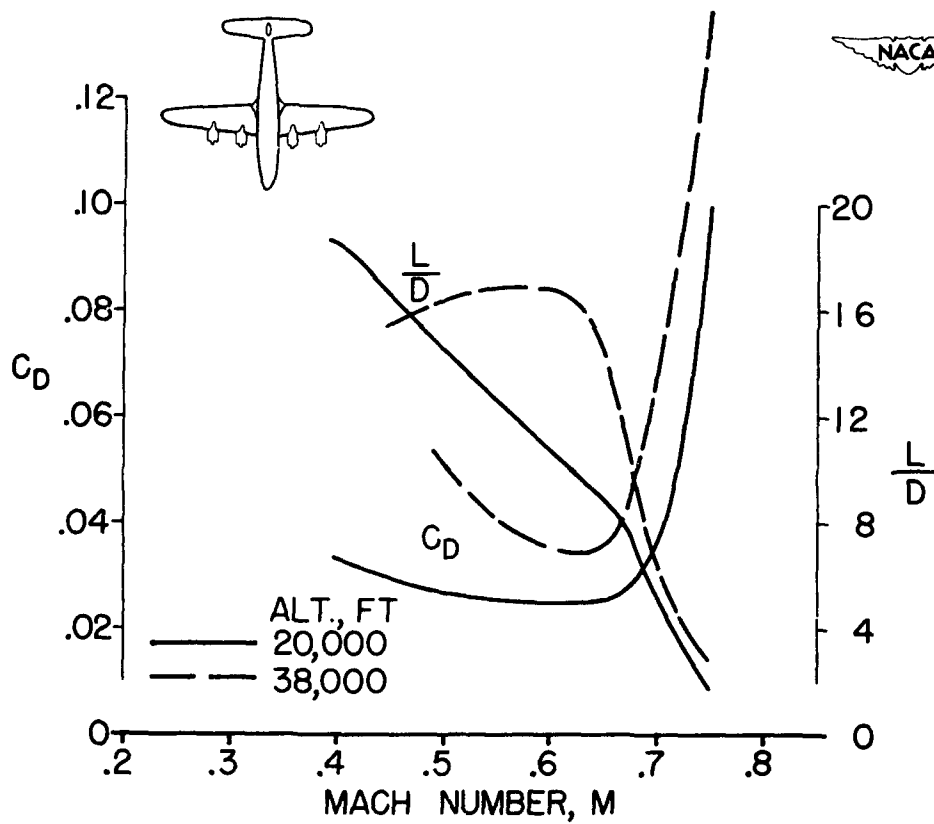

Figure 2. - Variation with Mach number of the drag coefficient and lift-to-drag ratio for level flight for a modern four-engine transport.

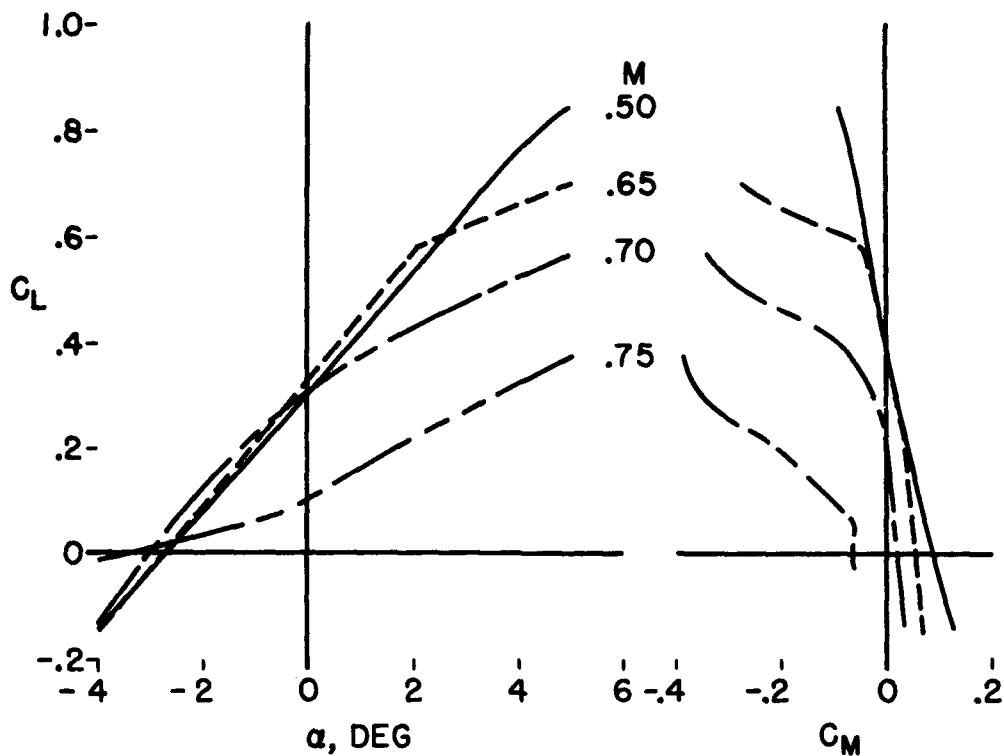

Figure 3. - Lift and pitching moment characteristics for a modern four-engine transport.

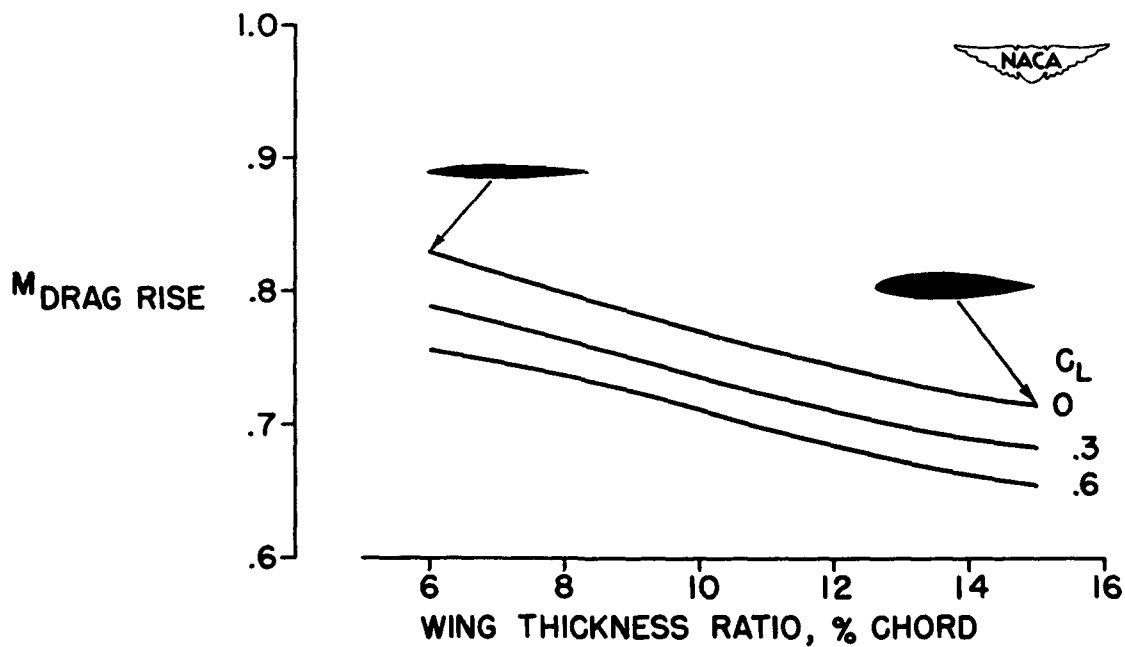

Figure 4. - Effect of wing thickness ratio on the Mach number for the drag rise.

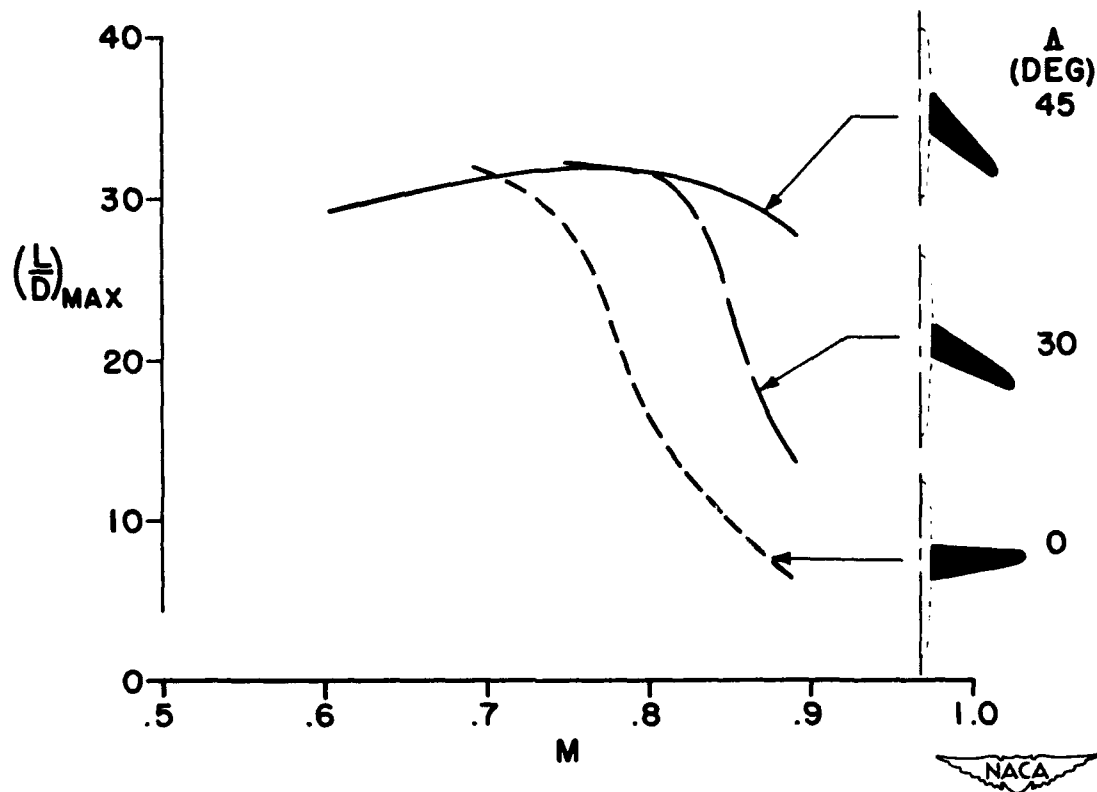

Figure 5. - Effect of sweep on the maximum lift-to-drag ratio.



Figure 6.

FORWARD A.C.
SHIFT, % MAC

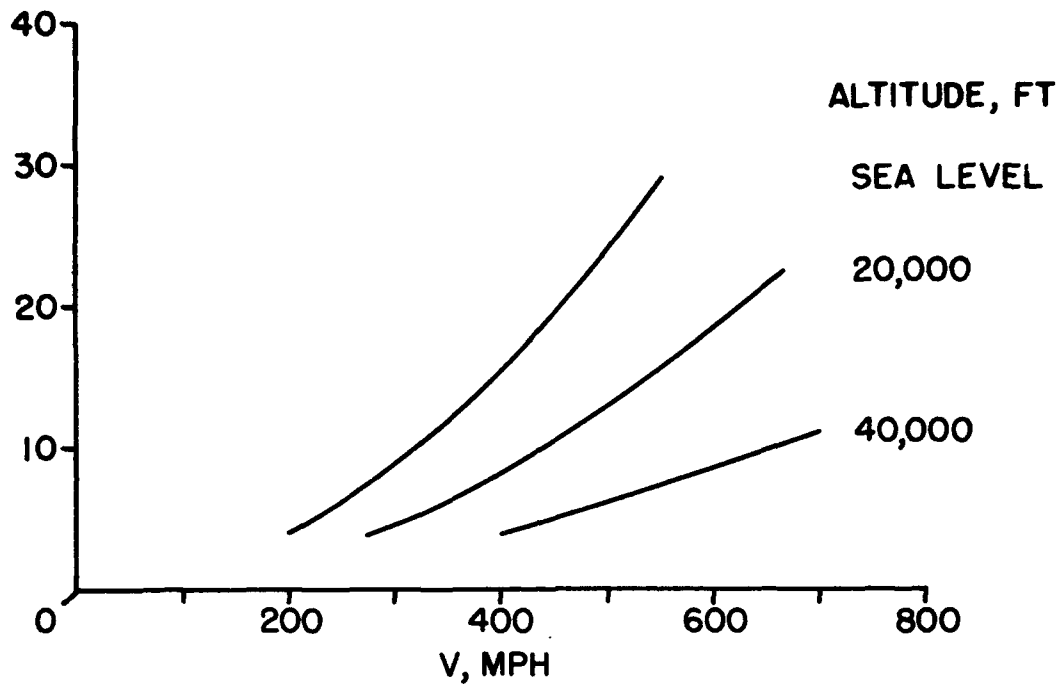

Figure 7. - Effect of speed and altitude on the forward aerodynamic center shift of a typical high-aspect-ratio swept wing.

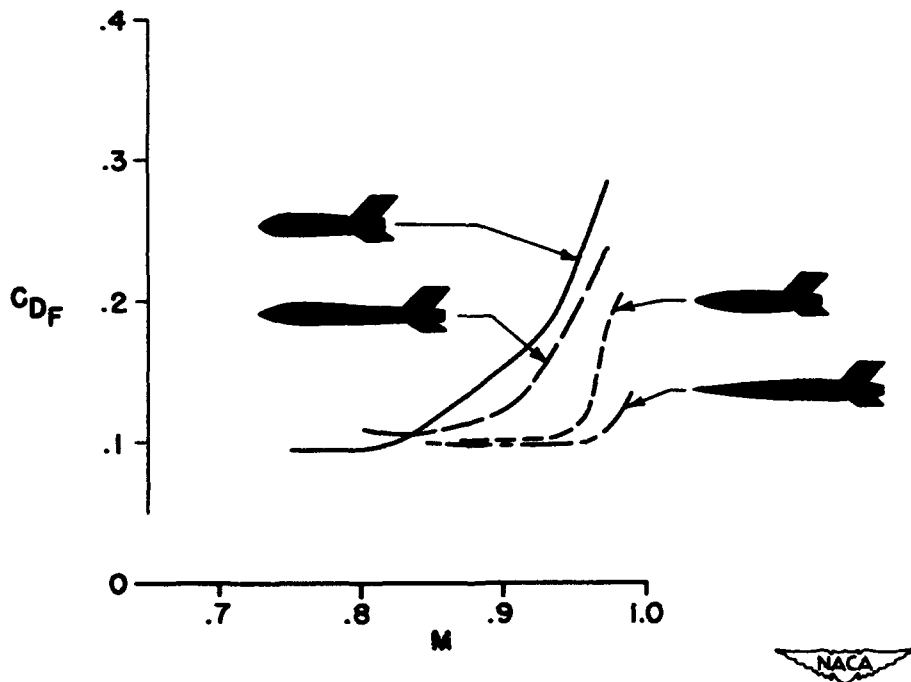

Figure 8. - Variation of drag coefficient with Mach number for several streamline bodies of revolution.

7
4
2
0
8
6
4
2
0

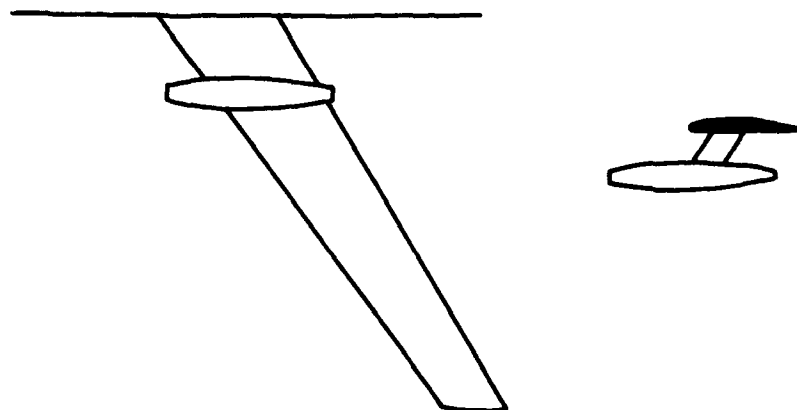

Figure 9. - Nacelle configurations.

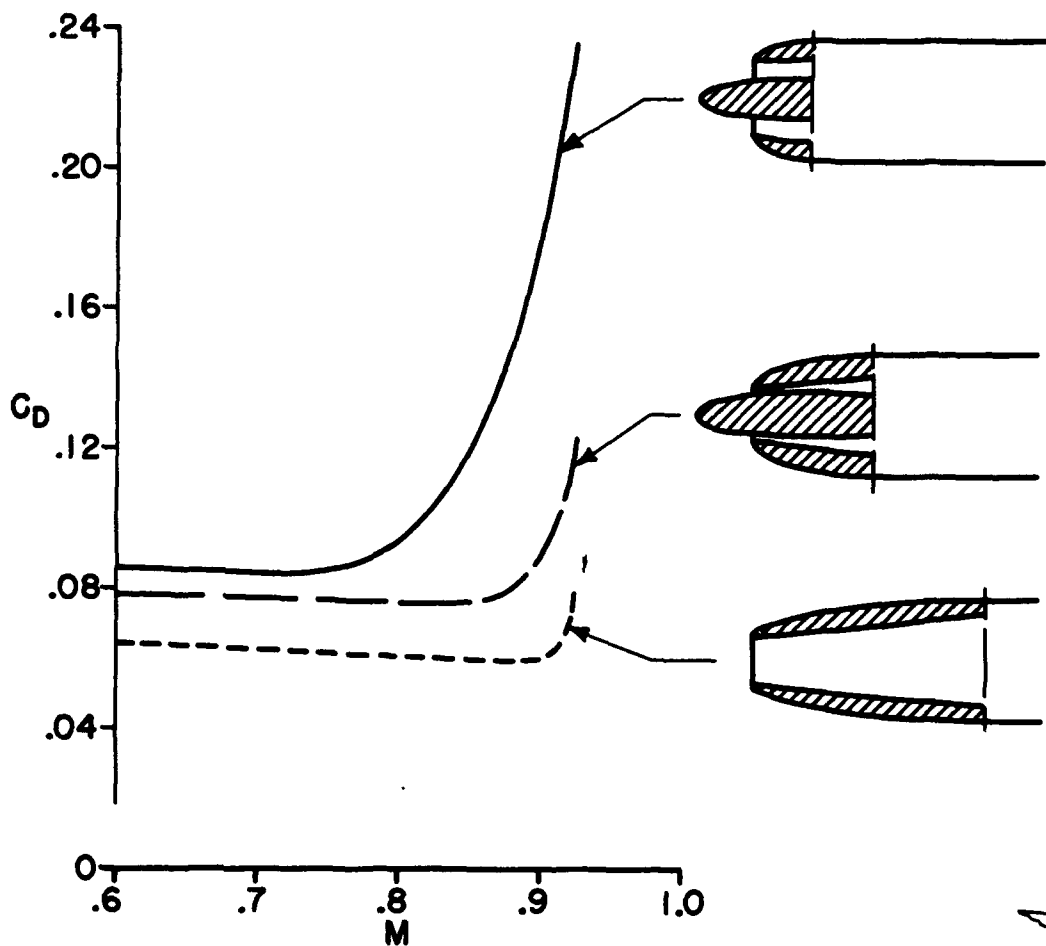

Figure 10. - Effect of Mach number on the external drag characteristics of three nose inlets.

NACA

12. PROBLEMS OF OBTAINING SATISFACTORY LOW-SPEED FLYING
QUALITIES FOR THIN-WING AND SWEEP-WING AIRPLANES

By Lawrence A. Clousing

AERODYNAMIC CONSIDERATIONS FOR HIGH-SPEED TRANSPORT AIRPLANES

12. - PROBLEMS OF OBTAINING SATISFACTORY LOW-SPEED FLYING

QUALITIES FOR THIN-WING AND SWEEP-WING AIRPLANES

By Lawrence A. Clousing

Ames Aeronautical Laboratory

Future high-speed aircraft will no doubt incorporate thin wings, swept wings, or thin swept wings. These types of wings, while very desirable from high-speed considerations, create a number of problems in obtaining satisfactory low-speed flying qualities.

For thin wings and wings of small values of sweepback, that is, for wings not exceeding about 35° of sweepback, the problem of obtaining satisfactory low-speed flying qualities is not very difficult of solution. A number of airplanes having sweptback wings of about 35° are operating with relatively satisfactory low-speed characteristics, the main differences in low-speed handling from those of conventional aircraft being due principally to the characteristics of the jet power plant rather than to the aerodynamic characteristics of the airplane. As sweepback of a wing becomes larger than about 35° , however, aerodynamic problems increase in magnitude pronouncedly. It is the problem of obtaining satisfactory low-speed flying qualities for the airplane with highly sweptback wing that at present prevents serious consideration being given to the use of highly swept-back wings on other than research airplanes, even though high values of sweepback offer considerable advantages at high speed.

It is the purpose of this paper to summarize the nature of the low-speed stability and control problems that arise through the use of thin-wing and swept-wing airplanes, and to briefly touch upon the results of research work accomplished or under way that indicate the possibility of ultimately providing satisfactory low-speed flying qualities for even very high sweptback wing airplanes.

The main problems created at low speed by use of thin wings are those of an increase in landing speed and a tendency toward undesirable stalling characteristics. Figure 1 shows the general trend of the variation of maximum lift coefficient with thickness ratio (references 1, 2, and 3). This variation is shown for an airfoil with

no flaps, and for an airfoil with a split flap. Note that maximum lift coefficient of the airfoil with flaps decreases continuously with decreases in thickness ratio throughout the range shown, and the decrease is more pronounced than for the airfoil without flaps. In terms of stalling speed, these data show that in the case of the airfoil with flaps, a 17-percent increase in stalling speed would result from decreasing the thickness ratio from 16 percent, which is typical of the thickness ratio on contemporary transport airplanes, to 9 percent which is probably typical of future airplanes. Below approximately 12-percent thickness ratio, a change in the nature of the initial flow separation at stall occurs (see reference 3). Instead of separation starting at the trailing edge, it may be expected to start at the leading edge. On airfoils of about 9 to 12 percent thickness ratio, this results in abrupt separation of the flow from the entire upper surface at stall with adverse effects on the nature of the stall and stall warning. Thus it is apparent that if maximum lift and satisfactory stalling characteristics are to be preserved on thin airfoils, leading-edge separation must be prevented or controlled.

Control of leading-edge separation is possible to a limited extent by use of camber and by making the leading edge more round, and to a large extent by use of slats, drooped leading-edge arrangements of various types, and suction. In figure 2 sectional forms of some types of leading-edge devices that have been studied with respect to their ability to control separation at the leading edge are shown (references 4, 5, 6, and 7). Their effectiveness in combination with several types of trailing-edge devices is also indicated. Although the values given are for airfoils of 12-percent thickness ratio, rather than for the thinner airfoils being discussed, comparable data on thinner wings not being available, enough is known to indicate that these data are indicative qualitatively of the effects of such devices on thinner airfoils. The airfoils shown on the right-hand side of the figure have no camber, whereas those on the left side have slight camber. It is apparent from a comparison with the plain airfoil sections that camber increases maximum lift coefficient. On the airfoils on the right, two types of drooped or extensible leading edges are shown, and it may be seen that each increases maximum lift coefficient whether applied to a plain wing or to a wing with a split flap. It will be observed that one type is much better than the other, pointing to the possibility that research will lead to even better arrangements. On the left, slats in combination with a plain wing and in combination with wings having double slotted flaps are shown. It may be seen that an increase in maximum lift comparable to that obtained with a drooped leading edge may be attained by use of a slat. As illustrated by the airfoil on the upper left, additional increase in maximum lift can be obtained by removing part of

the boundary layer by suction, in this case through a slot located at 40 percent of the chord.

From this brief summary of tests on high-lift devices, it is apparent that means exist for bringing the maximum lift of thin wings up to and in excess of the values that exist for wings of present-day conventional values of thickness ratio, but at the expense of adding gadgets to the leading edge. The addition of leading-edge slats or other devices need not, however, complicate piloting technique, as these devices may be made to operate automatically. Considerable satisfactory flight experience with automatic operation of slats has already been obtained.

If swept wings are used, the usable stalling speed tends to increase. The reasons for this are somewhat complex, and will now be explained. In actuality, maximum lift does not necessarily decrease with sweepback. In figure 3 the relative maximum lift as determined by experiment (references 8, 9, 10, and 11) and as predicted by simple theory is plotted as a function of sweepback angle. Also shown on the chart is the angle of attack for maximum lift plotted as a function of sweepback. The relative maximum lift shown is the ratio of the lift of the wing at a given angle of sweepback to the lift of a similar wing at zero sweepback. Notice that simple theory predicts a decrease in maximum lift with increase in sweepback. This simple theory is based on the fact that, as a wing is swept back, the component of velocity normal to the wing leading edge varies as about the square of the cosine of the angle of sweepback. Experiment shows that increase in sweepback is accompanied by a decrease in relative maximum lift smaller than that predicted by simple theory or even by no increase. This is one case, however, as will be explained, where simple theory is fairly representative of the practical aspects of the situation in regard to the usable lift of an unmodified sweptback wing. In itself, maximum lift cannot be used to evaluate the highest lift at which a swept-wing airplane may operate. The influences of attitude, pitching moments, and drag due to separated flow limit the usable lift of a swept-wing airplane. The influence of altitude, pitching moments, and drag will be discussed in turn, followed by a brief discussion of research work directed at modifying the sweptback wing to extend the limits imposed by these factors. The upper curve indicates the extent to which angle of attack of a sweptback wing must be increased to attain maximum lift, and is based on experimental data for wings of the plan forms shown (references 10 and 11). This curve shows that an angle of attack of about 37 degrees would be required to obtain maximum lift of a wing swept back 63 degrees, and that about 20 degrees angle of attack would be required to obtain maximum lift of a wing swept back about 45 degrees. Although no definite figure can be given here as to the largest angle of attack that can be used in practice for

landings and takeoffs, it is apparent that an acceptable attitude for an airplane will be less than the value of 37 degrees. There are means of minimizing the attitude problem here posed, and they will be mentioned later.

The limiting value of the lift of a sweptback wing is in essence a function of the nature and extent of separation of airflow that occurs prior to reaching maximum lift. Separation affects lift, pitching moments, rolling moments, and drag. The separation pattern shown in figure 4 is typical of the separation pattern of moderately sweptback wings (references 12 and 13). Here the separation patterns at three angles of attack indicated at A, B, and C are shown, and each pattern is correlated with the value of lift coefficient and pitching moment corresponding which are plotted as functions of angle of attack in the diagram above. Consider first the effect of a stall-pattern sequence of this type on the pitching moment that occurs as angle of attack is increased. As rough flow first occurs at A a nosing up tendency develops as shown by the change in the shape of the pitching-moment curve. As angle of attack is increased the upward trend of the pitching moment curve continues, and the extent of rough flow enlarges till the condition shown at B is reached. As the angle of attack is increased beyond the value at B the outer portion of the wing completely stalls abruptly, following a very small change in angle of attack; the center of lift moves abruptly forward, and an abrupt nosing-up pitching moment is produced as well as a loss of lift. The abrupt pitching up motion is very undesirable. It limits the lift value that may be used in practice irrespective of whether maximum lift is attained. On wings of higher values of sweep back the abrupt pitching up motion develops before maximum lift is reached. This is illustrated in figure 5, in which pitching moment is plotted as a function of lift coefficient for wings of 0, 45 and 63 degrees of sweep back. Note that on the 63-degree sweptback wing the pitching-up tendency developed at a lift coefficient of only .5, whereas the 45-degree sweptback wing it developed at a lift coefficient of approximately .7. In each case it is considerably below the value of maximum lift coefficient. Note also, in contrast, that the wing of zero sweepback developed a slight nosing-down tendency when separation occurred and that separation occurred at the maximum lift coefficient. Another point of interest is that the wing of 63-degrees sweepback developed an unduly large nosing-down tendency at a low value of lift coefficient. Although this nosing-down moment can be dealt with from the stability standpoint by the horizontal tail, the large nosing-down pitching moment would cause a considerable down load being required on the horizontal tail for balance with attendant loss of total airplane lift, increased size and weight of the tail, and increased drag. The effects regarding pitching moment are reduced in magnitude and may be eliminated if aspect ratio is reduced sufficiently,

but inasmuch as low-aspect-ratio wings would not afford economical operation this means for solution of the pitching moment problem will not be discussed.

Various devices may be used to control separation on swept wings and thereby eliminate the adverse pitching moments just discussed. Some of these devices, on which research studies have been carried out, are illustrated in figure 6 and the effect of each on the pitching moment of a 42-degree sweptback wing is shown (references 14 and 15). Note that when a normal split flap was used on the configuration shown to the left, the curve of pitching moment as a function of lift coefficient broke in a nosing-up direction at the maximum value of lift coefficient. The addition of a leading flap as shown, however, caused the pitching moment to break in a desirable direction, and extended the maximum lift coefficient as well. When a slat was used the end result was favorable, but an undesirable region of instability occurred just before maximum lift was developed. This unstable region was removed by the addition of an upper-surface fence located at the inward end of the slot.

It should be noted that the foregoing discussion has dealt with the pitching moment effect of the wing alone. The addition of a horizontal tail would tend to alleviate the adverse effects shown.

The results of separation with regard to rolling and buffeting tendencies (figure 4) will be discussed from the standpoint of stall warning and stalling characteristics. The fact that separation occurs near the tip and spreads inboard abruptly would appear to indicate that such a wing would have undesirable roll when this occurred, and that there would be a loss in aileron effectiveness. On another more highly sweptback wing, however, as shown in figure 7, separation progresses rather gradually with change in angle of attack, inasmuch as a 12-degree change in angle of attack is required for separation to develop to the extent shown. This could indicate that adequate stall warning by buffeting might exist, and that roll-off might not occur abruptly. The probable stalling characteristics of swept-wing airplanes are not yet fully predictable. Evidence to date indicates that the roll-off tendencies at stall on airplanes with highly swept wings may not be as adverse as once thought, and flight data to date in general indicate relatively good stalling characteristics are possible of attainment on sweptback-wing airplanes.

As pointed out earlier, the occurrence of separated air flow, should be considered also because of its effect on increasing drag. The effect of separation is to cause an unduly large increase in drag before maximum lift is reached. This increase required greater engine power to sustain level flight than would be the case if there

were no separation, or putting it another way, separation increases the power-off glide angle. The lift-drag ratio, an important factor to consider in regard to the glide angle and sinking speed, is shown in figure 8 as a function of lift coefficient for wings of constant wing panel aspect ratio set at sweepback angles of 0, 45, and 63 degrees. It will be noticed that the combined effects of sweepback, decrease in aspect ratio, and separation cause the lift-drag ratio of the sweptback wings shown to be quite low at the lift coefficients probable during approach and landing. It is known that the value of the lift-drag ratio of an airplane during approach and landing has a significant bearing on the ease with which a pilot can effect a landing (references 16 and 17). If the ratio is too high, the glide path is too shallow and the airplane tends to float during landing. If the ratio is too low, the power-off sinking speed and glide angle become large. Flight tests have indicated that if the lowest possible power-off sinking speed during approach is greater than 25 feet per second, pilots will have difficulty in making consistently good power-off landings. However, pilots have landed research airplanes satisfactorily with power off even though sinking speeds were considerably higher than 25 feet per second. In these cases, however, large areas were available for landing so that the need of landing at a given spot was eliminated. The lower limit of lift-drag ratio, as determined by landing considerations, has not yet been established. Sufficient information is available, however, to indicate that lift-drag ratio will have a definite bearing on pilot technique at landing and take-off.

The characteristics of flaps in increasing the lift of sweptback wings will now be discussed. Figure 9 shows, for the case of a typical flap installation, the increment of maximum lift coefficient due to flaps plotted as a function of sweepback (reference 18). It will be noted that the increment of maximum lift coefficient decreases with increase in sweepback, becoming zero at about 60 degrees of sweepback. Flaps nevertheless offer a considerable advantage even on very highly swept back wings. This advantage can be explained by reference to the diagram in the upper right in which lift coefficient is plotted as a function of angle of attack for the case of a wing with no flap and for the case of a wing with a flap. It may be observed here that the increment of maximum lift coefficient is not indicative of the increment at any given angle below the angle of attack for maximum lift. This is true even for wings of sweep back up to 60 degrees and higher. As has been pointed out earlier, the maximum lift that can be utilized will be at some angle of attack below that for maximum lift. Thus, even though no increment in maximum lift coefficient is available from flaps on highly swept back wings, an appreciable increment is available at the values of lift that can be used. A curve of the increment of lift coefficient due to flaps at some angle less than the angle for maximum lift would be at an increment of lift coefficient about .2 above the curve shown and roughly parallel to it.

Although flaps are useful on sweptback wings, and slats and drooped leading-edge arrangements are a means of controlling leading-edge separation (references 19, 20, and 21), their combined effect is not sufficient to provide completely satisfactory characteristics for highly sweptback wings. Twisting a swept wing from the root to the tip so that the tip is at a smaller angle of attack and varying the camber along the span also helps to delay separation on a sweptback wing (reference 22), but more help is needed.

The use of leading-edge suction is a method for the improvement of swept-wing characteristics that shows considerable promise. Reduction of drag is also possible by the use of suction, but this phenomenon will not be discussed here, important as it is. The application of suction will be considered primarily in regard to its usefulness in improving the pitching-moment characteristics. Figure 10 shows a 48-degree sweptback-wing model having an aspect ratio 3.4. A slot of .005 chord length was located at the leading edge as is shown in the plan form and sectional views. Air was drawn in through the slot and discharged through the wing by means of the duct shown in the sectional view. The effect on the pitching moment of sucking a moderate amount of air through the slot at the leading edge is shown on the curves. Note that without suction the curve of moment coefficient showed an undesirably large nosing-down tendency above a lift coefficient of .9, and that it showed an undesirable abrupt pitching-up tendency at a lift coefficient of about 1.0. It will be noted that the pitching-up tendency at stall was changed to a pitching-down tendency by use of suction in a slot of 50-percent of the span, and that a higher value of lift was obtained by use of the suction. The use of a 74-percent-span slot increased the lift obtainable before an abrupt pitching tendency occurred, but it did not eliminate the pitching-up tendency. Further research on the use of suction for the improvement of the low-speed characteristics of swept wings is in progress and it is showing considerable promise.

Other means of obtaining satisfactory low-speed characteristics for swept-wing airplanes are those of employing a wing of variable incidence or of variable sweepback. Such means of eliminating the unsatisfactory low-speed characteristics of highly swept-wing airplanes are being investigated, but they offer considerable mechanical difficulty and will not be discussed here.

Figure 11 illustrates some points of interest with regard to lateral control at low speeds (references 23 and 24). The lower curve shows the rolling ability of ailerons, as sweep back is increased, in terms of helix angle at the wing tip of the swept wing in comparison to the helix angle at the wing tip of the wing of zero sweepback. It is seen that sweepback reduces the ability of the ailerons to create a

large wing-tip helix angle in roll. However, for the case shown in which the airplane aspect ratio and consequently the clamping in roll is reduced as sweepback is increased, the actual rolling velocity in degrees of roll per second does not change appreciably with sweepback. In the upper curve, the total aileron angle required to prevent roll when the airplane is at 7 degrees steady sideslip is shown as a function of sweepback. Notice that, as sweepback is increased, the ability of the aileron to hold the airplane in a steady sideslip is reduced. This reduction is due to both a reduction in aileron effectiveness and to an increase in dihedral effectiveness at the higher values of lift coefficient as sweepback is increased. The characteristics here illustrated may cause difficulty in effecting cross-wind landing and take-off, thereby resulting in cross-wind-landing and take-off conditions being one of the critical conditions determining aileron effectiveness requirements. Figure 12 illustrates some effects of sweepback on the lateral dynamic characteristics of airplanes. The number of oscillations required to damp a lateral oscillation to one half amplitude is plotted as a function of sweepback. It may be seen that as sweepback increases, any lateral oscillation that may occur, such as that due to a gust will be less rapidly damped and actually becoming unstable as indicated by infinite time being required for damping, at some value of sweepback, the exact value depending on other factors. The question as to whether or not the oscillation must be rapidly or need be only moderately damped depends on the period of the oscillation and the flight conditions (reference 25). At landing approach, the period is long, and, in general relatively low damping can be tolerated because the pilot can stop the oscillation rather easily by use of his controls. At cruising speeds, however, low damping cannot be tolerated because the period is short and it becomes difficult for the pilot to stop the oscillations.

Considerable research has been completed and additional work is being carried out relative to the problem of obtaining satisfactory lateral dynamic characteristics for swept-wing airplanes. Generalized studies have shown that much can be done by relatively simple changes to airplane configurations. Also, research studies have shown that the use of servomechanisms responding to various signals offer much promise as a means of providing satisfactory dynamic stability characteristics (reference 25). This work may be likened to that of employing apparatus somewhat similar to that of an auto-pilot for improving the dynamic characteristics of an airplane when flying under direct human pilot control.

In summary, thin wings and high values of sweepback intensify the landing and takeoff problems of airplanes. Up to 35° of sweep, the problems of landing and takeoff of airplanes can be dealt with by more or less conventional means; that is, by flaps and slats.

Above 35° of sweep, more extreme means are necessary. Drooped leading-edge arrangements, camber and twist, leading-edge suction, variable-incidence arrangements, and variable-sweep arrangements offer considerable promise. Considerable research and development, however, will be necessary.

REFERENCES

1. Cahill, Jones F.: Summary of Section Data on Trailing-Edge High-Lift Devices. NACA Rep. 938, 1949.
2. Abbott, Ira H., von Doehoff, Albert E., and Stevens, Louis S., Jr.: Summary of Airfoil Data. NACA Rep. 824, 1945.
3. Jacobs, Eastman N., and Sherman, Albert: Airfoil Section Characteristics as Affected by Variations of the Reynolds Number. NACA Rep. 586, 1937.
4. Quinn, John H., Jr.: Tests of the N.C. 64₁A212 Airfoil Section with a Slat, a Double Slotted Flap, and Boundary-Layer Control by Suction. NACA TN 1293, 1947.
5. Loftin, Lawrence K., Jr.: Theoretical and Experimental Data for a Number of N.C. 6A-Series Airfoil Sections. NACA Rep. 903, 1948. (Formerly NACA TN 1368.)
6. Fullmer, Felicien F., Jr.: Two-Dimensional Wind-Tunnel Investigation of the NACA 64₁-012 Airfoil Equipped with Two Types of Leading-Edge Flap. NACA TN 1277, 1947.
7. Fullmer, Felicien F., Jr.: Two-Dimensional Wind-Tunnel Investigation of an NACA 64-009 Airfoil Equipped with Two Types of Leading-Edge Flap. NACA TN 1624, 1948.
8. McCormack, Gerald M., and Stevens, Victor I., Jr.: An Investigation of the Low-Speed Stability and Control Characteristics of Swept-Forward and Swept-Back Wings in the Ames 40- by 80-Foot Wind Tunnel. N.C. RM A6K15, 1947.
9. Anderson, Raymond F.: Determination of the Characteristics of Tapered Wings. NACA Rep. 572, 1936.

10. Johnson, Harold S., and Hagerman, John R.: Wind-Tunnel Investigation at Low Speed of an Unswept, Untapered Semispan Wing of Aspect Ratio 3.13 Equipped with Various 25% Chord Plain Flaps. NACA TN 2080, 1950.
11. Pasamanick, Jerome, and Sellers, Thomas E.: Low-Speed Investigation of Leading-Edge and Trailing-Edge Flaps on a 47.5° Sweptback Wing of Aspect Ratio 3.4 at a Reynolds Number of 4.4×10^6 . NACA RM L50EG2, 1950.
12. Purser, Paul E., and Spearman, M. Lercy.: Wind-Tunnel Tests at Low Speed of Swept and Yawed Wings Having Various Plan Forms. NACA RM L7D23, 1947.
13. Koven, William and Graham, Robert R.: Wind-Tunnel Investigation of High-Lift and Stall-Control Devices on a 37° Sweptback Wing of Aspect Ratio 6 at High Reynolds Numbers. NACA RM L8D29, 1948.
14. Conner, D. William, and Neely, Robert H.: Effects of a Fuselage and Various High-Lift and Stall-Control Flaps on Aerodynamic Characteristics in Pitch of an NACA 64-Series 40° Swept-Back Wing. NACA RM L6L27, 1947.
15. Neely, Robert H., and Conner, D. William.: Aerodynamic Characteristics of a 42° Swept-Back Wing with Aspect Ratio 4 and NACA 64₁-112 Airfoil Sections at Reynolds Numbers from 1,700,000 to 9,500,000. NACA RM L7D14, 1947.
16. Lovell, J. Calvin, and Lipson, Stanley.: An Analysis of the Effect of Lift-Drag Ratio and Stalling Speed on Landing-Flare Characteristics. NACA TN 1930, 1949.
17. Gustafson, F. B. and O'Sullivan, William J., Jr.: The Effect of High Wing Loading on Landing Technique and Distance, with Experimental Data for the B-26 Airplane. NACA ARR L4KO7, 1945.
18. Letko, William, and Goodman, Alex.: Preliminary Wind-Tunnel Investigation at Low Speed of Stability and Control Characteristics of Swept-Back Wings. NACA TN 1046, 1946.
19. Graham, Robert R., and Conner, D. William: Investigation of High-Lift and Stall-Control Devices on an NACA 64-Series 42° Sweptback Wing with and without Fuselage. NACA RM L7G09, 1947.

20. Salmi, Reino, J.: Effects of Leading-Edge Devices and Trailing-Edge Flaps on Longitudinal Characteristics of Two 47.7° Swept-back Wings of Aspect Ratios 5.1 and 6.0 at a Reynolds Number of 6.0×10^6 . NACA RM L50F20, 1950.
21. Foster, Gerald V. and Fitzpatrick, James E.: Longitudinal-Stability Investigation of High-Lift and Stall-Control Devices on a 52° Sweptback Wing with and without Fuselage and Horizontal Tail at a Reynolds Number of 6.8×10^6 . NACA RM L8108, 1948.
22. Hunton, Lynn W.: Effects of Twist and Camber on the Low-Speed Characteristics of a Large-Scale 45° Swept-Back Wing. NACA RM A50A10, 1950.
23. Soule, Hartley A.: Influence of Large Amounts of Wing Sweep on Stability and Control Problems of Aircraft. NACA TN 1088, 1946.
24. Langley Research Staff (Compiled by Thomas A. Toll): Summary of Lateral-Control Research. NACA Rep. 868, 1947. (Formerly NACA TN 1245.)
25. Kauffman, William M., Liddell, Charles J., Jr., Smith, Allan, and Van Dyke, Rudolph D., Jr.: An Apparatus for Varying Effective Dihedral in Flight with Application to a Study of Tolerable Dihedral on a Conventional Fighter Airplane. NACA Rep. 948, 1949. (Formerly NACA TNs 1788 and 1936.)

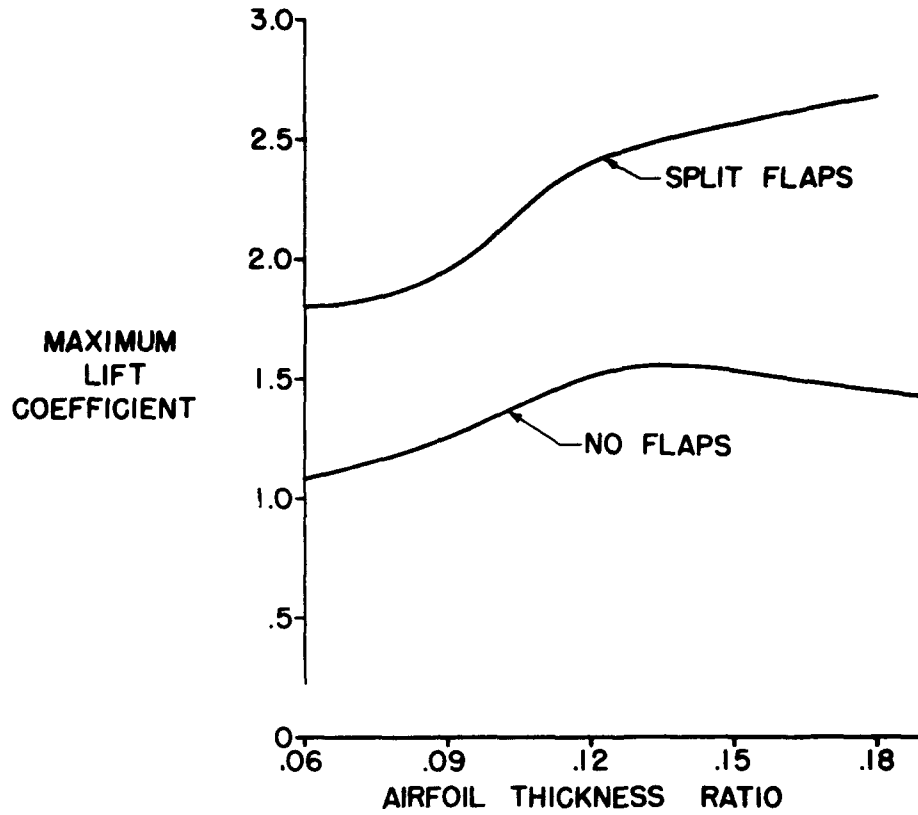

Figure 1. - Effect of airfoil thickness ratio on the section maximum lift coefficient with and without flaps.

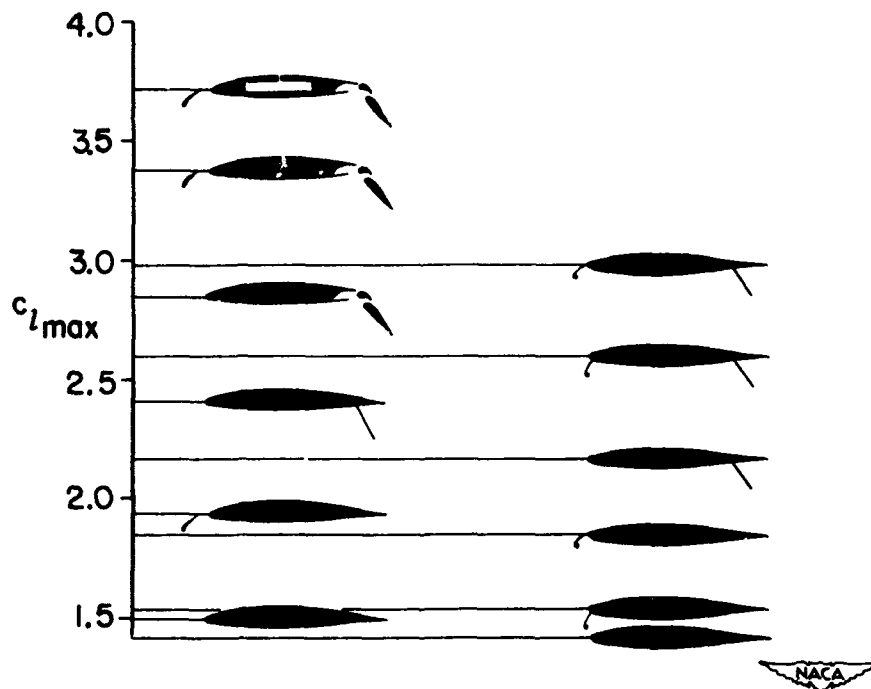

Figure 2. - Some types of leading-edge and trailing-edge devices, and their effect on section maximum lift coefficient.

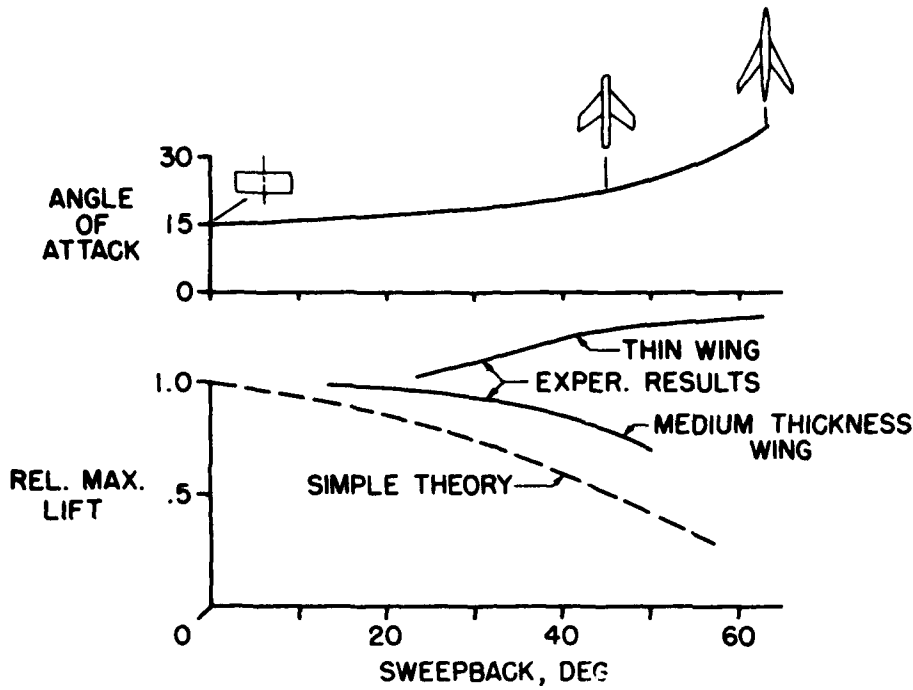

Figure 3. - Effect of sweepback on the angle of attack for maximum lift and on the ratio of the maximum lift at a given angle of sweepback to the maximum lift at zero sweepback.

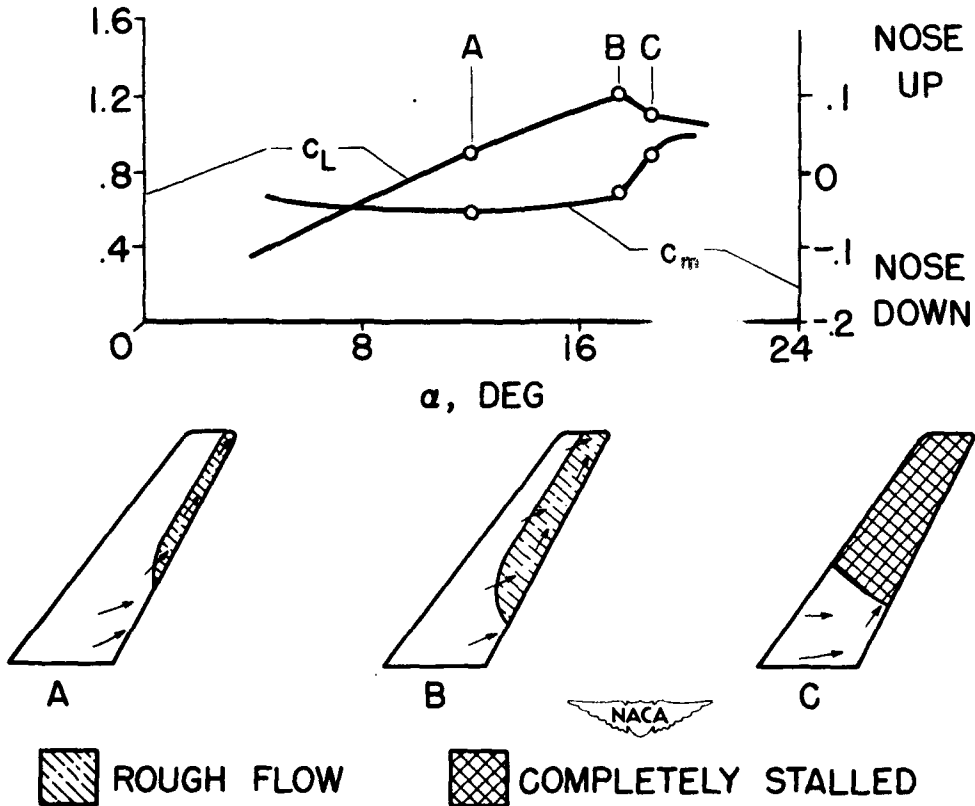

Figure 4. - Nature of the development of airflow separation on a moderately swept back wing and its effect on the pitching moment.

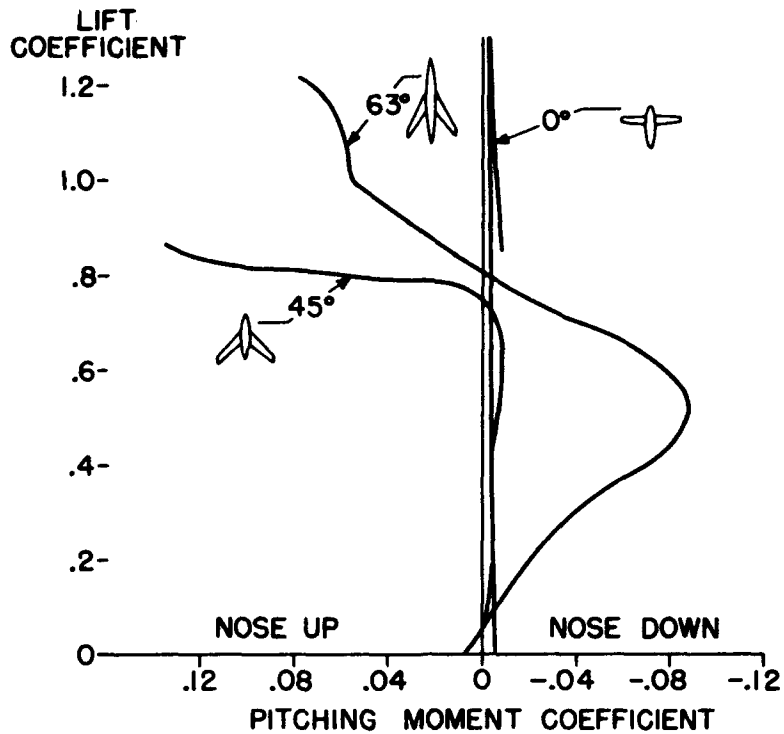

Figure 5. - Effect of sweepback on the characteristics of the variation of pitching moment with lift coefficient.

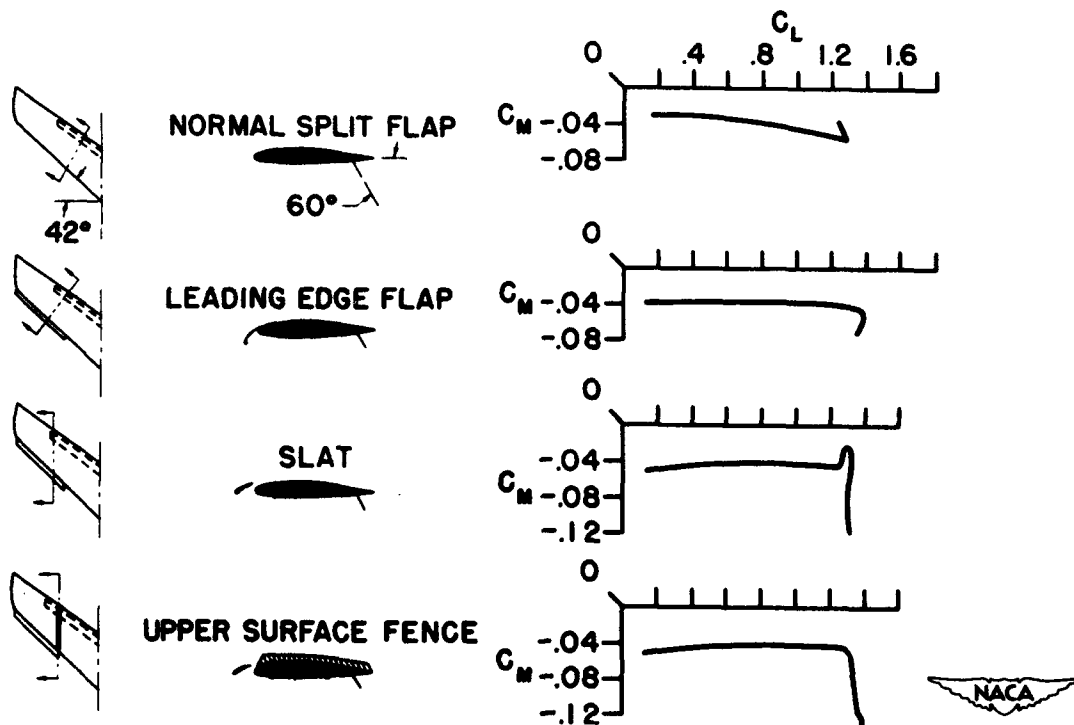

Figure 6. - Effect of high-lift and stall-control devices on pitching moment.

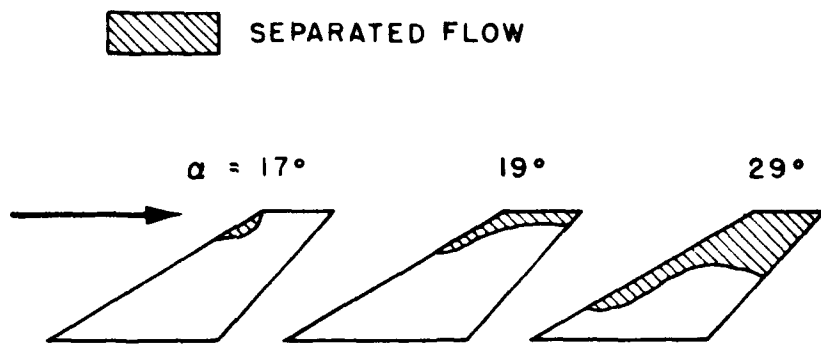

Figure 7. - Nature of the development of separation on a wing of fairly large sweepback.

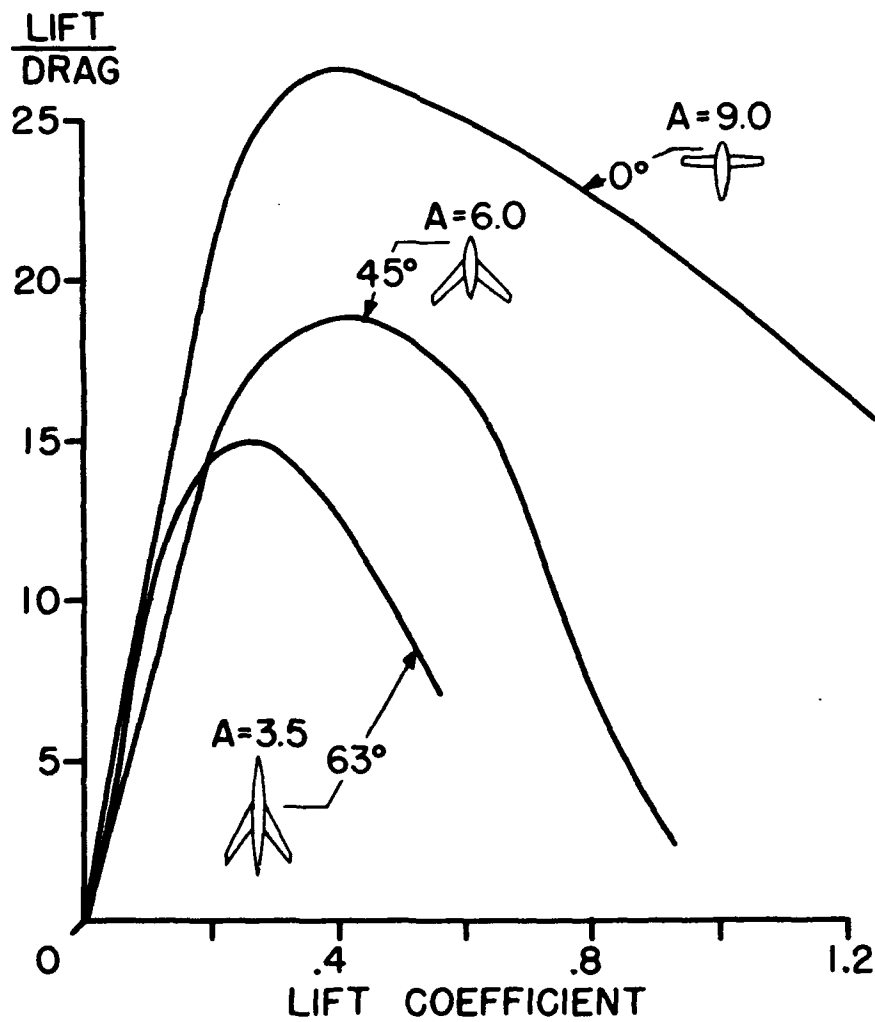

Figure 8. - The value of lift-drag ratio as a function of lift coefficient for three wings having different values of sweepback and aspect ratio.

INCREMENT
OF LIFT
COEFFICIENT

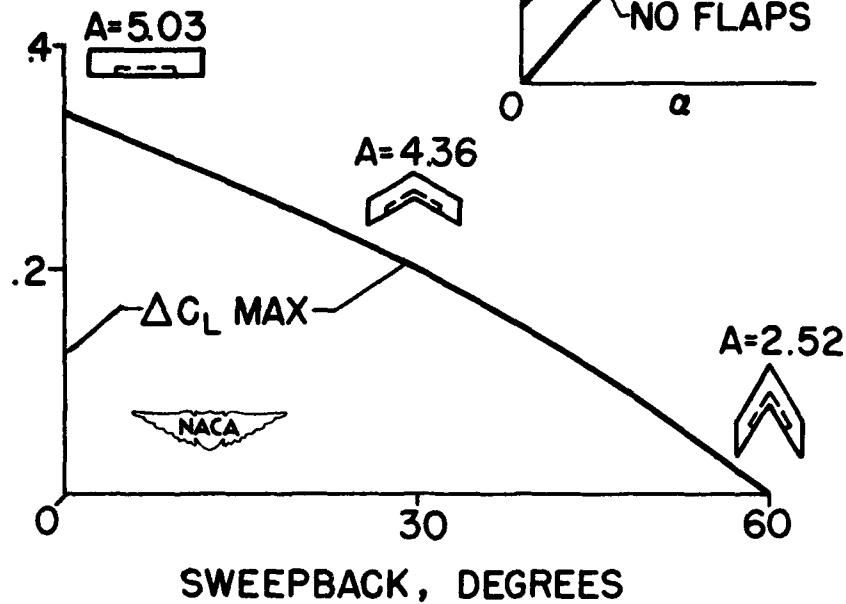

Figure 9. - Increment at various angles of sweepback of maximum lift due to flaps.

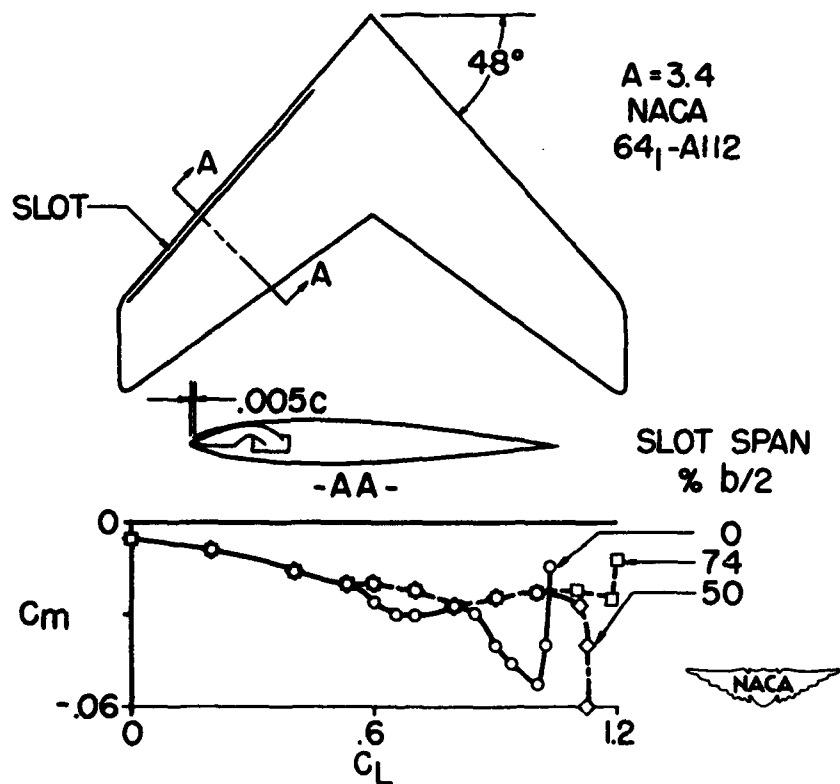

Figure 10. - Effect of suction at the leading edge on the pitching moment at various lift coefficients.

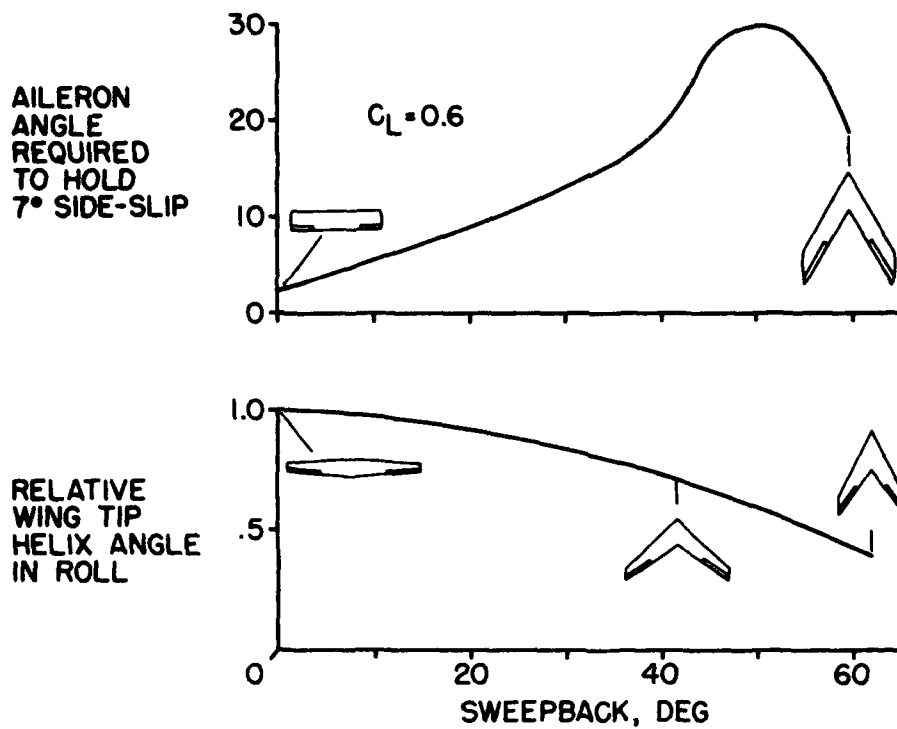

Figure 11. - Lateral control as affected by sweepback.

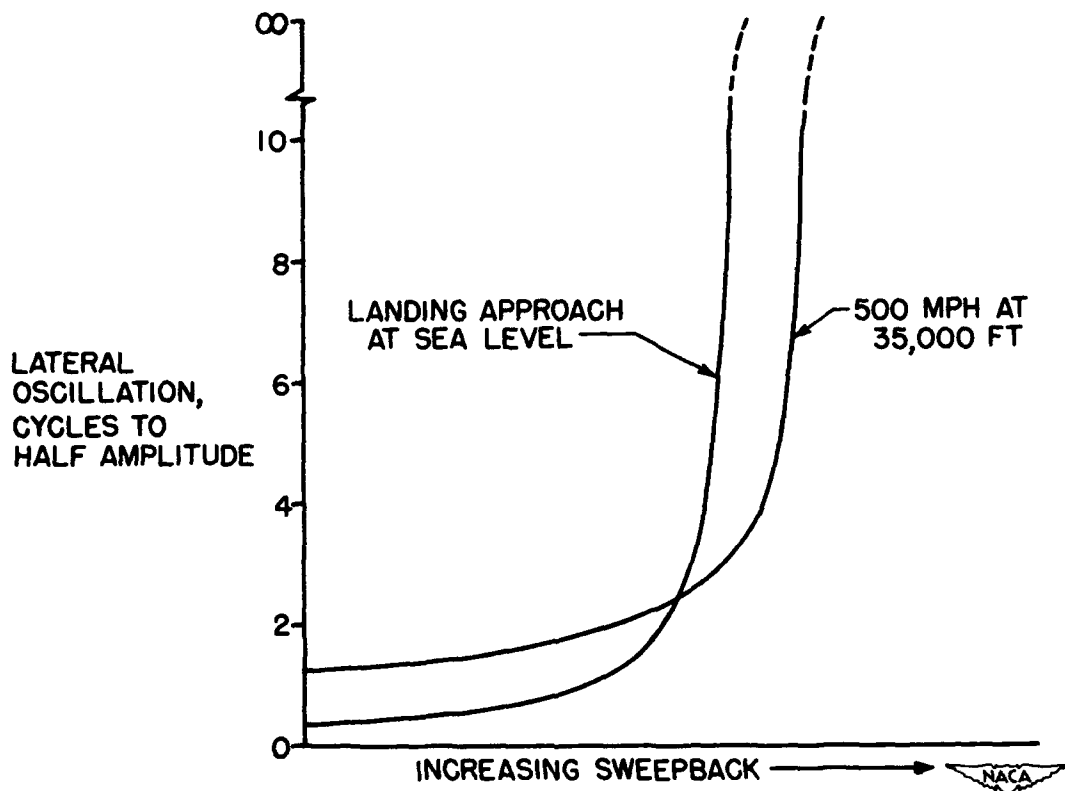

Figure 12. - Lateral dynamic stability as affected by sweepback.

13. SPEED BRAKES FOR HIGH-SPEED TRANSPORT AIRPLANES

By Jack D. Stephenson

AERODYNAMIC CONSIDERATIONS FOR HIGH-SPEED TRANSPORT AIRPLANES

13. SPEED BRAKES FOR HIGH-SPEED TRANSPORT AIRPLANES

By Jack D. Stephenson

Ames Aeronautical Laboratory

The development and operation of large airplanes capable of high speeds at high altitudes have indicated the existence of new problems that must be met before the performance possibilities of these airplanes can be fully exploited.

One problem that has gained importance is that of descending from high altitude when the time of the descent must be reduced to a minimum. Improved aerodynamic design which has effected substantial reductions in drag of transport airplanes has added to the danger of excessive diving speeds. The combination of low drag and high engine power available at high altitude has brought practical cruising speeds near to the maximum placard speed. For turbojet airplanes the cruising speed has been estimated at as high as 95 percent of the maximum permissible speed.

The permissible speed at the higher altitudes for most airplanes is determined by compressibility effects and is specified in terms of the airplane Mach number. With only a narrow margin between the operating speed and the maximum allowable Mach number, overspeeding may occur under conditions which would precipitate severe stability changes and buffeting before there is time to take preventive measures.

At lower altitudes, the diving speed of most airplanes is limited to the indicated speed for which the structure is designed. At this speed the maximum dive angle of an aerodynamically clean airplane may be quite low, and the rate of descent considerably less than that desired. The most important use of aerodynamic brakes on transport airplanes is then to avoid excessive diving speeds and permit high rates of descent.

The amount of aerodynamic braking that is considered essential to some transport aircraft is based upon criteria that mean extremely high rates of descent. One such criterion is the requirement intended to minimize the potential danger of flight at altitudes where cabin pressurization is necessary. If the cabin pressure should suddenly be lost as a result of damage to the pressurized compartment, first consideration

would be given to descending with minimum delay to an altitude where pressurization is unnecessary. In an emergency descent such as this, there is evidence that rates of descent as high as 15,000 feet per minute or higher are to be desired. Similar high rates of descent would be sought if brakes are provided as a safety device to allow an emergency descent and landing, occasioned, for example, by the discovery of fire while in flight.

An example of the descent performance of a transport airplane with an aerodynamic brake of a size that appears to be structurally feasible is illustrated in figure 1. The dotted curve is the flight path of the airplane descending without brakes, and the solid curve is the path that might be followed if brakes are employed.

By use of air brakes, the time for descent from 35,000 feet to sea level has been reduced from 18 minutes to 3.1 minutes. The change in the descent performance shown here cannot be considered as a general indication of brake performance, however.

The performance of any particular brake depends not only upon the brake itself, but also upon airplane characteristics, such as wing loading, drag, and engine thrust, and upon flight conditions at the time when the braking is required.

The rate of descent of an airplane under any given set of conditions may be used as a measure of brake performance, since the drag increment due to a particular brake can be estimated fairly closely and thus related to rate of descent.

It has been indicated that the speed of a diving airplane is normally limited by compressibility effects or structural loadings. The rate of descent of an airplane having these speed limitations is shown in figure 2 for three diving attitudes. The solid curves are the calculated vertical speed as a function of altitude for an indicated airspeed of 300 miles per hour and the dotted curves are for a Mach number of 0.7. The graph may be used to show the effect of altitude on the rate of descent of an airplane for which the speed is at first held at a constant Mach number: at the altitude where the maximum permissible indicated speed is attained at that Mach number, the descent is then made at constant indicated airspeed. The dive angles that were chosen, 20° , 25° , and 30° , are based upon the airplane attitude as determined from the flight-path angle and angles of attack, assuming a wing loading of 60 pounds per square foot. The airplane attitude that is acceptable in an emergency descent is a factor that must be further evaluated with regard to transport airplanes. The disconcerting effect upon the passengers of experiencing a force tending to pitch them forward may be a major factor in limiting the rate of descent.

With the airplane nosed down 20° , a rate of descent of more than 10,000 feet per minute is attainable at all altitudes above 5,000 feet.

For steeper angles, the vertical speeds increase approximately in proportion to the diving attitude.

The attainment of the rates of descent shown is possible, however, only if there is available the means of producing a considerable drag force. Without such a drag, the speed could not be restricted to the values shown.

Figure 3 shows as a function of indicated airspeed, the drag coefficients required to prevent increases in the speed of the airplane for the same three dive angles. The drag coefficient plotted here is the calculated value for the complete airplane with braking devices, and, if there is a residual thrust from the engine, the drag must be further increased to balance such thrust. The dotted curve in this figure is the variation of the drag coefficient with indicated airspeed for a typical high-speed transport. A comparison of the latter curve with the curves of drag coefficient required for descent indicates that if the speed is low, very high drag increments must be provided by the aerodynamic brakes.

Drag requirements are relatively moderate if the descent may be made at a high forward speed. In figure 4, vertical speed is presented as a function of altitude for three indicated airspeeds, 300, 350, and 400 mph, and two Mach numbers, 0.7 and 0.8. An airplane attitude of 20° and a wing loading of 60 pounds per square foot have been assumed. It is evident that high forward speed permits the highest rates of descent.

Although the most rapid descent results from high speeds, the ability to maintain a low forward speed often would be extremely advantageous. For example, the ride-roughness level might then be kept within satisfactory limits for passenger airplanes. These limits are discussed in reference 1. If an emergency descent were made during excessive atmospheric turbulence, high forward speeds might easily result in dangerous gust loadings.

The effect of airplane wing loading on the drag coefficient required for descent with an airplane dive attitude of 20° is shown in figure 5. The curves, which compare wing loadings of 40, 60, and 80 pounds per square foot, show that the drag coefficient varied practically in proportion to the wing loading. The possibility of increased cruising speeds of transports is leading to substantially higher wing loadings and is one of the primary reasons that the braking problem is now gaining such importance.

Another factor indicating the increasing importance of braking is the rapid decrease in indicated speed, or dynamic pressure, as the altitude increases for any given Mach number. Present designs for transports, particularly those with turbojet power, are aimed at high operating altitudes to take advantage of the increased fuel economy. With the low dynamic pressure corresponding to the allowable Mach number, drag coefficients must be increased many times over the values for the clean airplane.

If a fuselage-type aerodynamic brake were employed to produce an airplane drag coefficient of 0.1, which is the value shown corresponding to an indicated airspeed of 290 miles per hour and a wing loading of 60 pounds per square foot, the brake would have an area of at least 7 percent of the wing area. This would mean for a present-day 60-passenger transport, which did not have available the braking due to its propellers, the total area of the brake would be about 100 square feet. The large size indicated here is a result of the extreme descent performance requirements, and corresponds to a vertical speed of 15,000 feet per minute at an altitude of 30,000 feet. At 10,000 feet altitude the rate of descent would be 10,600 feet per minute.

The preceding discussion of air brakes has been based upon a simplification of the braking problem, in order to establish some of the maximum limits of brake performance, assuming that the attainment of very high vertical speeds is the principal problem. The extent to which these speeds may be possible, however, depends upon other factors besides the ability to provide sufficient drag.

In an emergency resulting from loss of cabin pressure at high altitude, the passengers would be at the outside pressure altitude. A high rate of pressure increase resulting from high vertical velocities is known to be objectionable. Even when cabin decompression has not occurred, the allowable rate of pressure change would limit a descent at low altitudes since, below 8,000 or 9,000 feet, the cabin pressure would again be about equal to the outside pressure.

The value of aerodynamic brakes cannot be gauged by consideration of the emergency-descent problem alone. As an auxiliary speed control, brakes have proved to be particularly valuable to turbojet aircraft, which lack the braking effect provided by an engine-propeller combination during a throttle-back glide. During a landing letdown and approach, they may be used to quickly reduce the speed so that the landing gear and flaps may be operated, or that the airplane may better conform to traffic-control-zone conditions.

Brakes may be employed so as to alleviate some phases of the range problem of turbojet aircraft. In order to arrive at the destination with the required reserve fuel and additional range, during the latter portion of the flight, the pilot might maintain high altitude instead of making a gradual descent at a speed for high lift-drag ratio. The amount of reserve fuel required to reach an alternate airport would then be considerably less than that required if the flight to the alternate airport were made at low altitudes, or if such a flight involved climbing again to a more efficient altitude. Under such conditions, when the let-down is finally made, it probably would be accomplished as rapidly as practicable, consistent with passenger-comfort requirements.

Although values might be chosen to represent satisfactory speed control and glide-path control, the significance of these values can be established only from operational experience. Obviously, the drag

increments required of the brakes in these applications are considerably less than those required for emergency descents.

Aerodynamic brakes have been successfully employed on many types of airplanes. Their use with transports is relatively recent, but experience with other types of airplanes provides a good basis for their evaluation.

Since aerodynamic brakes are primarily only a device for increasing airplane drag, and are not otherwise greatly restricted, they have a wide variety of geometric characteristics. For the same reason they have been located on airplanes in a variety of places. In some cases the landing gear has been designed to serve as an air brake, when extended. More commonly, the brakes have consisted of hinged plates or flaps (sometimes perforated) on the wing or large retractable panels on the fuselage side or belly. Figure 6 shows some of these types of air brakes: (a) a perforated brake of the split flap type on the wing, (b) three plain panels on the fuselage aft of the wing, (c) a large folding panel on each side of the fuselage and (d) spoiler-type brakes on the wing.

Aerodynamic brakes as shown on the upper surface of the wing have been found to cause increases in the airplane drag amounting to more than twice the drag of an isolated plate of the same size. The high effectiveness of this type of brake is due to its spoiler type of action causing flow separation over the wing. This type of brake has the advantage that the airplane angle of attack may be increased, reducing the diving attitude in a steep descent. A spoiler type of brake may be unfavorably affected by compressibility, increasing buffeting tendencies or stability changes to which an airplane may be subject at high Mach numbers. Aerodynamic characteristics of this type of brake are presented in references 2 and 3.

The fuselage type of brake, if extended to a position approximately perpendicular to the air stream, has been found to produce a drag increase about equal to that due to the brake alone (see reference 3). By designing this type of brake installation so that the wake is a sufficient distance from the tail surfaces of the airplane, it is possible to avoid buffeting due to the brakes, and prevent appreciable changes of stability when the brakes are extended, even at Mach numbers greater than 0.9.

Another type of braking is provided by reversing propeller pitch in flight. In reference 4 tests are reported indicating that the reversed thrust from the propeller offers a very powerful means of braking propeller-driven airplanes. This paper describes tests of a multi-engine transport airplane during which rates of descent of 11,000 feet per minute were obtained at an indicated airspeed of 200 miles per hour, well below the maximum placard speed. The remarkable descent performances that were obtained indicate that this type of braking should be developed for the general use of airplanes for which the descent problem is important, and if possible adapted to turbopropeller installations.

Flights of a single-engine turbojet airplane were made at the NACA Ames Aeronautical Laboratory to measure the time required for descent from 35,000 feet without aerodynamic brakes and with brakes of the fuselage-side type. The first chart in figure 7 is a comparison of the drag coefficients just after the start of the descents. A large part of the total drag in both cases was not available to assist in the descent, because it was cancelled by the thrust of the engine, as shown by the cross-hatched portion of this graph. This large thrust, which remained when the engine was throttled back, is characteristic of present jet engines.

The second chart is a comparison of the time required for the two descents. Without brakes, the descent to 10,000 feet, which was made at an indicated speed of 365 miles per hour, required 15.7 minutes. With the brakes extended, the time for the descent at the same indicated speed was reduced to 2.5 minutes.

The aerodynamic problem of providing air brakes for a particular airplane centers primarily upon the determination of the required braking force. This force depends upon the wing loading of the airplane, the air speed, and altitude at which the brakes are needed, as well as the deceleration or the angle of the flight path which results from the use of the brakes. If these factors can be specified, available data from wind-tunnel and flight tests may be used to determine the brake-size requirements. The tests of the specific configuration may be needed to see that the brakes do not introduce adverse stability or trim effects or cause buffeting.

Experience in the operation of various types of airplanes has proved that aerodynamic brakes are a valuable addition as an auxiliary control of flight characteristics. Research on brake effectiveness has made it possible to select brakes that are aerodynamically suitable to provide the control important to the operation of transport-type airplanes. Although there remain mechanical and structural problems associated with the addition of brakes to any given transport, benefits possible through the use of aerodynamic brakes can be realized by judicious use of the available results of tests and experience.

REFERENCES

1. Shevell, Richard S.: Operational Aerodynamics of High-Speed Transport Aircraft, Jour. Aero. Sci., vol. 15 no. 3, March, 1948, pp. 133-143.
2. Fischel, Jack, and Watson, James M.: Investigation of Spoiler Ailerons for Use as Speed Brakes or Glide-Path Controls on Two NACA 65-Series Wings Equipped with Full-Span Slotted Flaps. NACA TN 1933, 1949.

3. Stephenson, Jack D.: The Effects of Aerodynamic Brakes upon the Speed Characteristics of Airplanes. NACA TN 1939, 1949.
4. Fisher, Herbert O.: Investigation of Reversing Propeller Pitch on a Multi-Engine Aircraft in Flight. SAE Preprint 458, presented before SAE Nat. Aero. Meeting (New York), April 17-20, 1950.

201013

EFFECT OF AERODYNAMIC BRAKES UPON FLIGHT PATH

INDICATED AIRSPEED, 300 MPH

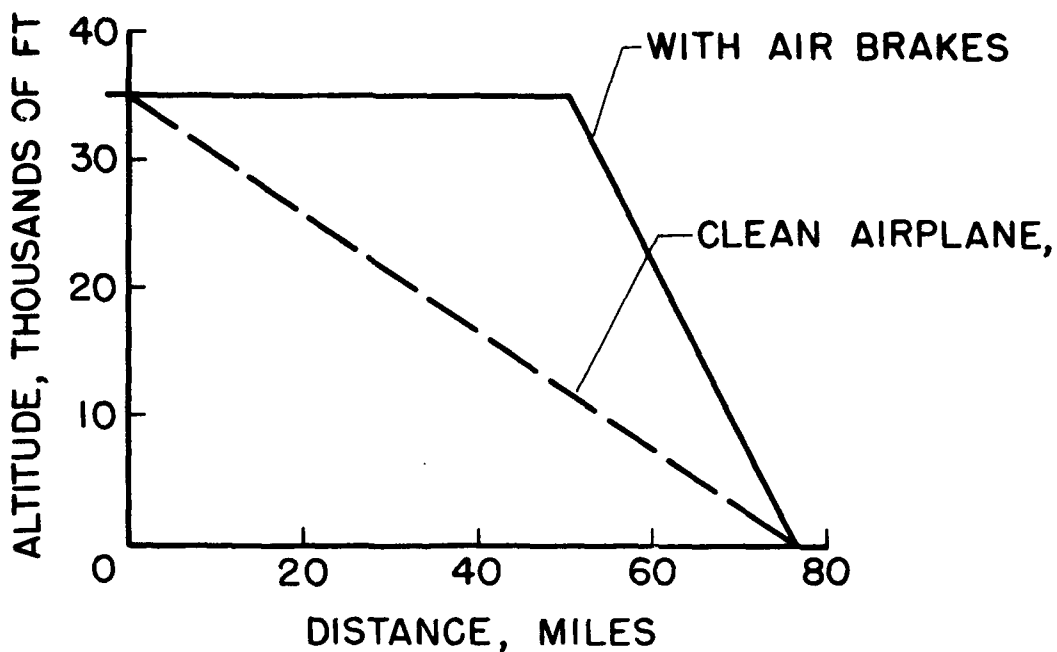

Figure 1

EFFECT OF ALTITUDE ON RATE OF DESCENT

WING LOADING, 60 LB/SQ FT

AIRPLANE NOSE DOWN 30°

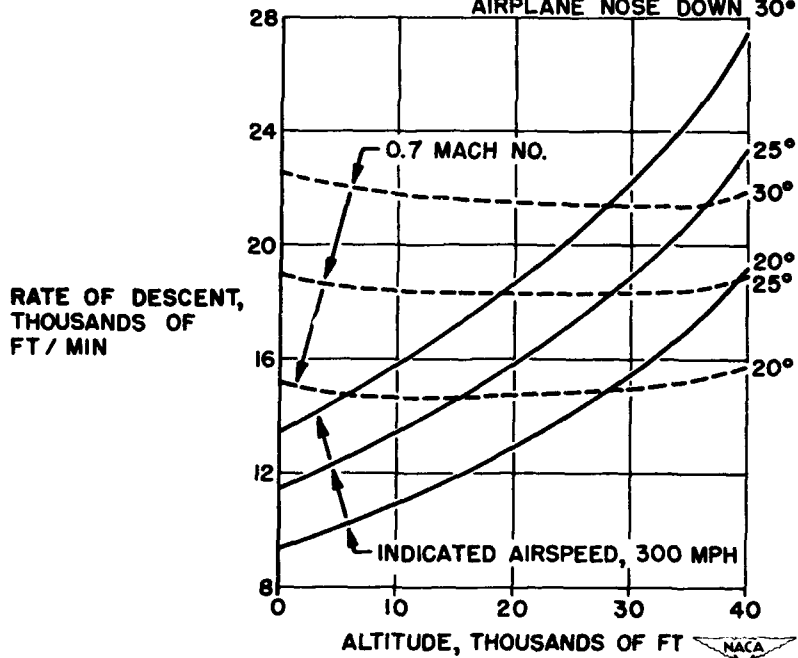

Figure 2

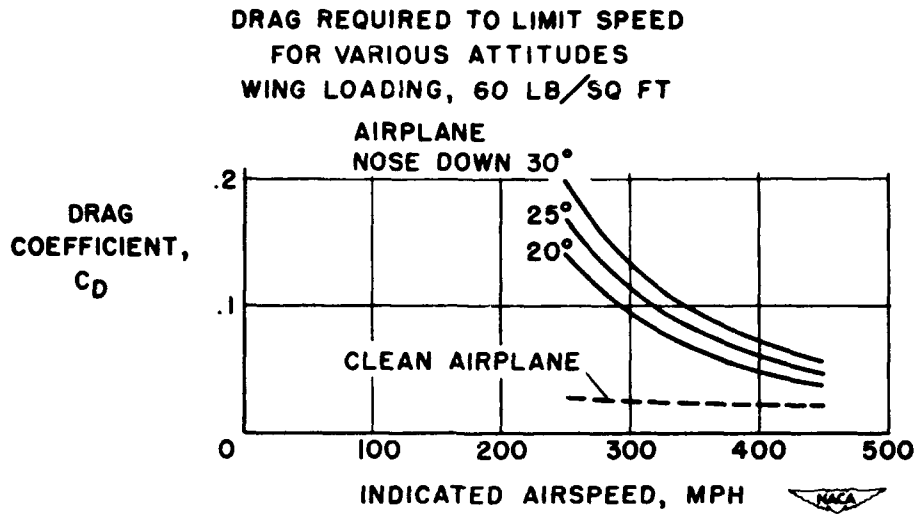

Figure 3

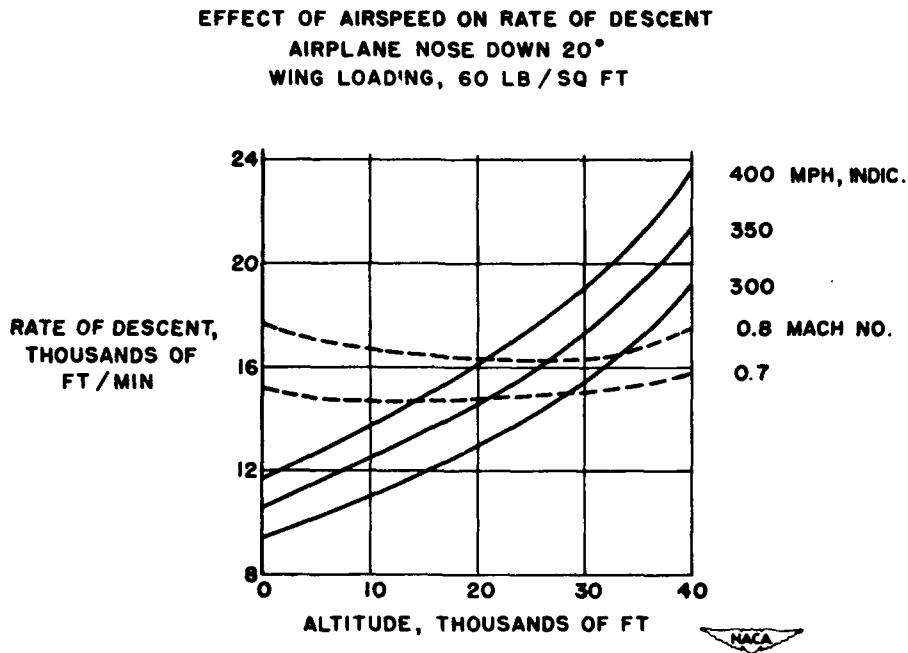

Figure 4

DRAG REQUIRED TO LIMIT SPEED
FOR VARIOUS WING LOADINGS
AIRPLANE NOSE DOWN 20°

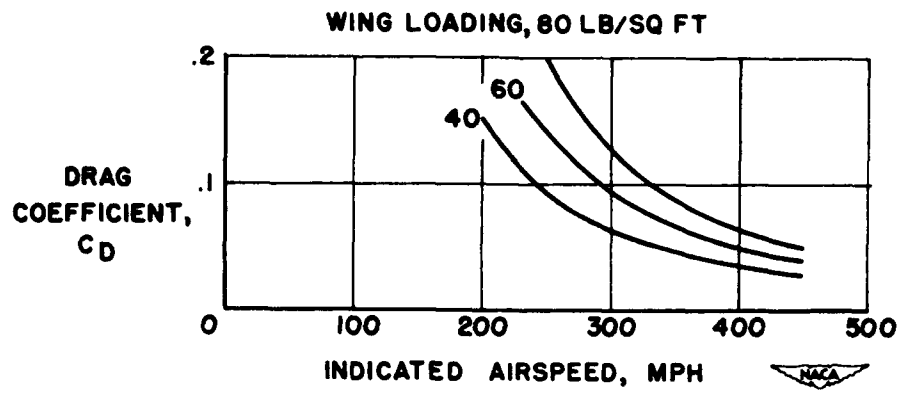

Figure 5



Figure 6

N
S
A
C

FLIGHT MEASUREMENT OF EFFECTIVENESS
OF AERODYNAMIC BRAKES

DESCENT FROM 33,000 FT TO 10,000 FT
INDICATED AIRSPEED, 365 MPH

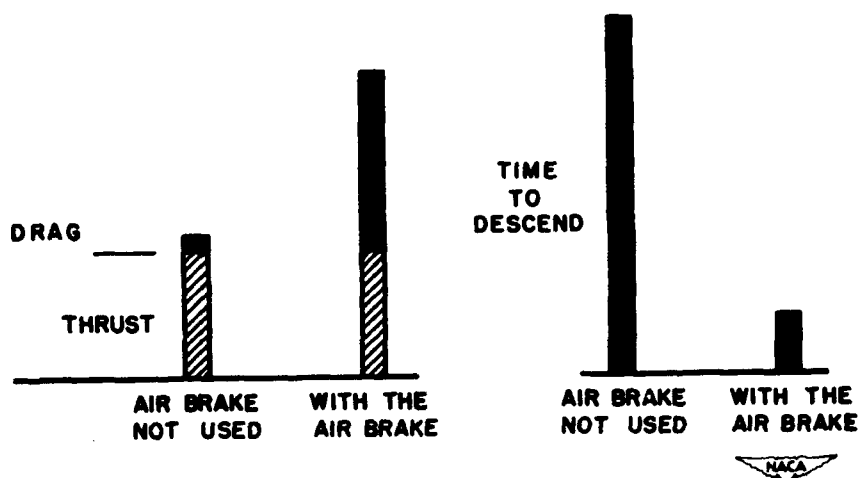

Figure 7

5

14. REVIEW OF HANDLING QUALITIES REQUIREMENTS IN RELATION
TO AIRPLANE OPERATING PROBLEMS

By Christopher C. Kraft, Jr.

AERODYNAMIC CONSIDERATIONS FOR HIGH-SPEED TRANSPORT AIRPLANES

14. REVIEW OF HANDLING QUALITIES REQUIREMENTS
IN RELATION TO AIRPLANE OPERATING PROBLEMS

By Christopher C. Kraft, Jr.

Langley Aeronautical Laboratory

The handling qualities of an airplane are defined as the stability and control characteristics that have an important bearing on the safety of flight and on pilots' impressions of the ease of flying an airplane. Some time ago the NACA realized the need for establishing some quantitative design criteria for describing what constitutes satisfactory handling qualities of an airplane. It was necessary to obtain a great deal of information from the flight tests of many different airplanes in order that some basis could be formulated for these requirements. Through the cooperation of the military services and the CAA, a large number of airplanes were made available to the NACA for this work; the airplanes varied in size from the light airplane class to the medium and heavy bomber type aircraft. Following the tests of quite a large group of these airplanes, a report entitled "Requirements for Satisfactory Flying Qualities of Airplanes" by R. R. Gilruth was published as a classified report in 1941. It should be noted that this publication is an evaluation by the NACA of the handling qualities desirable of a satisfactory airplane but the NACA has no power with which to enforce these requirements. A short time after this classified publication both of the military services adopted a similar group of requirements based on the NACA work. The military services specifications have since been used as a basis for acceptance of newly designed airplanes for both the Air Force and Navy. The CAA Airplane Airworthiness requirements also contain certain standards for stability and control characteristics, but these are less detailed and not as quantitative as the military services requirements. These specifications as adopted by the military services are also used as a standard for airplanes in the design stage. Preliminary design calculations, wind tunnel tests and finally flight tests are necessary to ensure that the airplane does meet the standards. Early in 1947 the original NACA publication became available to the general industry. Since the original NACA publication, the handling qualities of a great many more airplanes have been measured, and only a few minor additions not originally included in the requirements have been necessary.

A workable group of requirements necessarily contains a description of the technique necessary to measure the characteristics of the airplane and what characteristics are reasonable to require of an airplane without imposing penalties on the airplane performance. Pilot opinions were especially important in determining the control force characteristics that a satisfactory airplane should have. For example, the elevator control forces experienced by the pilot in performing an

accelerated maneuver must be low enough to allow the pilot to maneuver quickly and efficiently, but on the other hand must be large enough to allow the pilot to precisely regulate the load on the airplane. Many other important concepts contained in the requirements were obtained by the correlation of pilot opinions with the measurements made on the airplane. It should also be noted that the testing techniques that have been set forth by the NACA publication were so arranged as to allow for data that could be repeated and results which were quantitative.

The handling qualities specifications are subdivided under the headings of longitudinal stability and control, lateral stability and control, and stalling characteristics. As an example of what is covered under these titles the subheadings covered under longitudinal stability and control are dynamic stability, static stability, elevator control in accelerated flight, elevator control in landing and take-off conditions, limits of trim change due to power and flaps, and the characteristics of the trimming devices. The handling qualities of the airplane which come under the other headings are covered in a similar manner, but the entire handling qualities specifications are too numerous to allow discussion in this paper.

In order to illustrate the application of the handling qualities requirements, a brief discussion of some of the tests made on typical large-scale transport airplanes is presented herein. Figure 1 shows the characteristics of a test airplane in accelerated flight for the power-on clean condition. These tests were made in steady turns at a constant speed and acceleration. The curves show the elevator angle and elevator force as a function of normal acceleration for three different indicated airspeeds, 200, 150, and 120 miles per hour at a center-of-gravity position approximately midway between the specified limits of this airplane. The requirements for the airplane of this particular class and load factor states that the force per g in accelerated maneuvers shall be between 20 and 60 pounds and that the elevator shall be capable of producing either maximum lift coefficient or maximum load factor. The variation of elevator angle with normal acceleration is also required to have a stable slope and in maneuvering flight the rearward movement of the stick shall not be less than 4 inches when the airplane lift coefficient is changed from 0.2 to the maximum lift coefficient obtainable. It is apparent from these data that the force per g of this airplane at this center-of-gravity position is excessive at all of the speeds investigated since the curves show that the force required to reach 2 g acceleration is 160 pounds or more. The curves also show that the variation of elevator angle with normal acceleration is in the correct direction, that is, a stable slope, and that the maximum lift coefficient or maximum load factor could have been reached if the elevator forces had not been excessive. In addition the pilots reported that in all cases more than 4 inches of stick travel would have been required to reach maximum lift coefficient. From these data, it can be

seen that the stick force characteristics of this airplane in accelerated flight were below the standards set forth by the handling qualities specifications, but that the elevator control was entirely satisfactory.

Figure 2 presents the aileron control characteristics of a typical large airplane. Shown on the slide are the aileron force and aileron effectiveness parameter, $pb/2V$, as a function of total aileron angle. The parameter $pb/2V$ is the helix angle generated by the wing tip as the airplane rolls. The data shown are for the power-on clean condition at 150 miles per hour and the flaps and gear down condition at 120 miles per hour which would be comparable to a landing approach configuration. These data were obtained by making rolls out of turns with various amounts of aileron deflection and with the rudder held fixed. The handling qualities specify that the aileron effectiveness parameter, $pb/2V$, shall be at least 0.07 with a maximum wheel force of 80 pounds. The tests show that the maximum $pb/2V$ that could be reached at 150 miles per hour without exceeding 80 pounds wheel force was approximately 0.07, but in the flaps and gear down condition at 120 miles per hour the maximum $pb/2V$ that could be obtained with this wheel force was 0.06. Therefore, the airplane met the requirements in the power-on clean condition, but was slightly below the standards in the flaps and gear down condition.

It is interesting to note the pilot's opinion of the aileron effectiveness in the flaps and gear down condition. This configuration corresponds to a landing approach and the pilot was dissatisfied with the high aileron control forces necessary to roll the airplane because both hands would be required to exert this amount of force. During a landing approach, the pilot is inclined to hold only one hand on the wheel while the other is used to adjust the throttles and other necessary controls, and for this reason the pilot would desire lower aileron force to obtain an equivalent amount of lateral control.

An important and very often overlooked characteristic of an airplane is the amount of friction in the controls. The Air Force and Navy handling qualities requirements specify that the maximum allowable friction force in a transport type aircraft should be 15 pounds in the rudder control, 8 pounds in the elevator control, and 6 pounds in the aileron control. It was possible for the airplane from which these data were obtained to change the friction from twice these limits to about 1/2 of these allowable values. This afforded a good measure of the effects of friction in handling the airplane during flight involving small control displacements.

Figure 3 presents a time history of the rudder angle and rudder force during two different landings, one with high friction forces in the controls, and the other with low friction. The vertical lines indicate the time at which the airplane made ground contact. In both cases the pilot was able to safely land the airplane, but the pilot disliked the landing

with high friction. It is obvious from the time history of the landing with high friction in the controls that there was little response of the rudder to the pilot's force application. The landing with low friction in the controls still required the same amount of force application by the pilot but the rudder responded and allowed the pilot to make a much more satisfactory landing.

The magnitude of friction force becomes exceedingly important during precision flying such as in an instrument approach since the aerodynamic forces are low and small control movements are desired. If the friction forces are too large, the following undesirable characteristics are created: (1) the aerodynamic forces cannot be accurately trimmed to zero, thus allowing the controls to "creep" and necessitating constant retrimming of the airplane, (2) the controls when displaced from trim will not return when the control forces are released, (3) the pilot no longer has control feel for small control displacement because the deflection is not proportional to the applied force, and (4) it is extremely difficult to make small control adjustments without undershooting or overshooting the desired position.

During the past several years there has been some question as to the need for revision or amendment to the handling qualities requirements. The NACA has made several handling qualities investigations during the past few years with the special intent of seeking items not covered by the present requirements. The results of these tests have indicated that had the airplanes tested met the requirements as they now stand, the airplanes would have been considered acceptable.

As an example of the tests made by the NACA to seek items not covered by the present requirements the specifications for asymmetric power conditions require the rudder to be powerful enough to limit the angle of bank to a maximum of 5 degrees and the yawing velocity to zero. This particular airplane met this requirement, but the question was raised as to whether the pilot would have sufficient time to take corrective action following engine failure.

Figure 4 shows a time history of the angle of bank and angle of sideslip following failure of the number one engine of a four-engined transport airplane. Two flight tests are shown, one where the controls were held fixed and the airplane was allowed to roll off, and the other where corrective action was taken by the pilot. These particular tests were made in the take-off configuration. The curves for the case where the controls were held fixed indicate that the angle of bank increased at a slow rate and that six seconds was required for the airplane to reach 40 degrees bank. This was considered ample time for the pilot to take corrective action. The dotted lines on this figure are the results obtained when the pilot applied the controls following the engine failure. It is apparent that the pilot had little trouble in controlling

the airplane. These tests proved that the airplane characteristics were satisfactory following an engine failure. Another example of the recent handling qualities tests are the problems involved during a landing approach. During a landing approach, especially an instrument landing, there has been some doubt as to the most efficient technique that could be used to correct for lateral displacement from the runway. From a discussion with quite a number of pilots, two maneuvers were suggested, one was coordinated turns, and the other level sideslips. Some of the pilots felt that they would not bank a large airplane during the final approach and would only use the wings level maneuver; however, a large number of flight records of simulated instrument approaches indicated that coordinated turns with limited angles of bank are more frequently used.

Figure 5 presents some of the results that were calculated for a large four-engine transport to determine which technique would be the most effective. The abscissa of this plot is the distance in feet from the end of the runway, and the ordinate is the lateral distance in feet from the centerline of the runway. The two solid curves presented here are not flight paths but a series of starting points of a flight path such as that shown, where the airplane was originally flying parallel to the runway and this given amount of lateral displacement was required to bring the airplane to the center line of the runway. In other words, if the airplane were 2000 feet from the end of the runway and performed a coordinated turn maneuver, the pilot would be able to laterally displace the airplane about 200 feet following this type of flight path. Similarly, if the level sideslip maneuver were used, the pilot would be able to displace the airplane about 100 feet, again following a flight path such as that shown. In making the calculations for the level sideslips maneuver, the pilot was assumed to use first full left rudder and then full right rudder followed by enough left rudder to return the airplane to its original heading. The coordinated turns were assumed to be performed in a similar manner, that is, using first left and then right rolls to laterally displace the airplane. Also, in making the calculations of the coordinated turn method, the maximum amount of aileron effectiveness was assumed, and the angle of bank was limited to a maximum of 17 degrees, which would be the angle at which the wing tip and the landing gear of this particular airplane would touch the ground at the same time. It can be seen from these data that the coordinated turns maneuver will correct for greater displacement than will level sideslips for all distances from the end of the runway. In fact, from 2000 feet on out, the coordinated turns maneuver is two or more times as effective as the level sideslips maneuver. Similar calculations were made limiting the aileron effectiveness parameter to about one-half, and the rudder deflection to one-half full rudder. These values would be more closely related to the amount of control normally applied by the pilot. The results showed a similar comparison between the two techniques, the amount of displacement obtainable being about one-half those shown on the figure.

It appears then that a good basis for satisfactory handling qualities has been established for the present conventional transport airplane, but with the coming of transonic and supersonic speeds, the problem of producing airplanes with satisfactory handling qualities is a serious one. As the conventional airplane of today approaches transonic speeds many new problems are introduced which are completely divorced from those at subsonic speeds. Large changes occur in trim, stability and hinge moment characteristics due to compressibility effects. If the airplane configuration is selected to minimize these adverse effects, undesirable low-speed handling qualities may be introduced. In order to provide satisfactory control forces on transonic airplanes, the use of control boosters with mechanical devices to provide control feel may offer a solution. Complicated stall-control devices may be required to obtain satisfactory low-speed handling qualities. The present handling qualities requirements provide the designer with the requirements for performance of these mechanisms that will result in satisfactory handling qualities of the airplane. However, as higher speeds are reached and airplane designs depart further from the conventional design of today, a great deal more research will be required to establish what the aerodynamic characteristics of an airplane must be to meet the handling qualities specifications.

REFERENCES

1. Gilruth, R. R.: Requirements for Satisfactory Flying Qualities of Airplanes. NACA Rep. 755, 1943.
2. Anon.: Specifications for Flying Qualities of Piloted Airplanes. NAVAER SR-119B, Bur. Aero., June 1, 1948.
3. Anon.: Air Force Specifications for Flying Qualities of Airplanes. Air Force Spec. 1815-B, June 1, 1948.
4. Talmage, Donald B.; Reeder, John P. and Matthews, Ruth G.: Flight Investigation of Longitudinal Stability and Control Characteristics and Stalling Characteristics of a C-54D Airplane. NACA RM L9L21, 1950.
5. Talmage, Donald B. and Reeder, John P.: Lateral and Directional Stability and Control Characteristics of a C-54D Airplane. NACA RM L8K30, 1949.
6. Talmage, Donald B., and Reeder, John P.: The Effects of Friction in the Control System and on the Handling Qualities of a C-54D Airplane. NACA RM L8G30a, 1948.
7. Faber, Stanley: Comparison of Effectiveness of Coordinated Turns and Level Sideslips for Correcting Lateral Displacement During Landing Approaches. NACA RM L9I29, 1949.

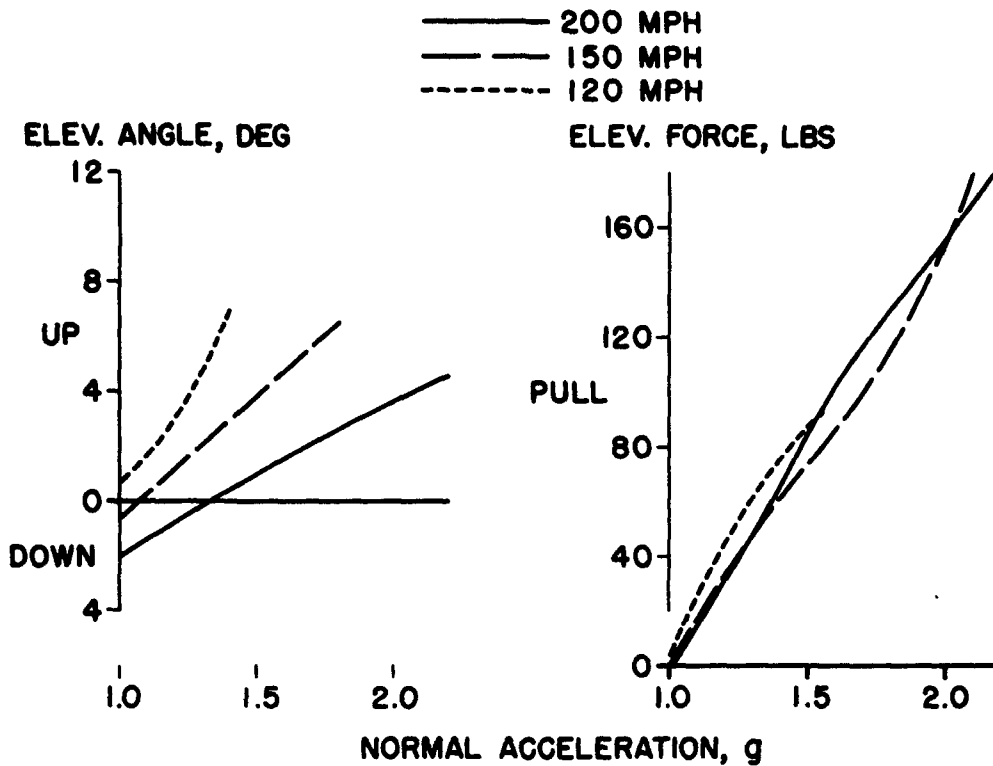

Figure 1. - Maneuvering stability characteristics in accelerated flight for a typical large scale airplane in the power-on clean condition.

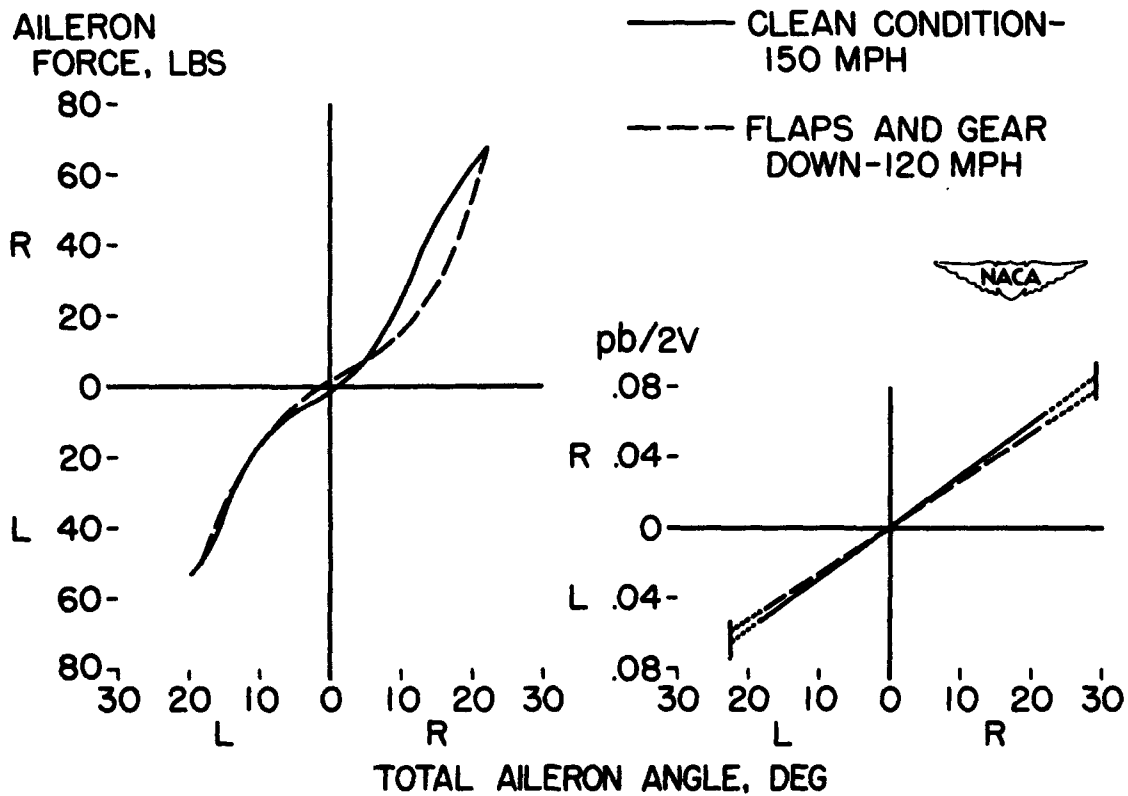

Figure 2. - Aileron control characteristics of a large transport airplane as measured in rolls out of turns.

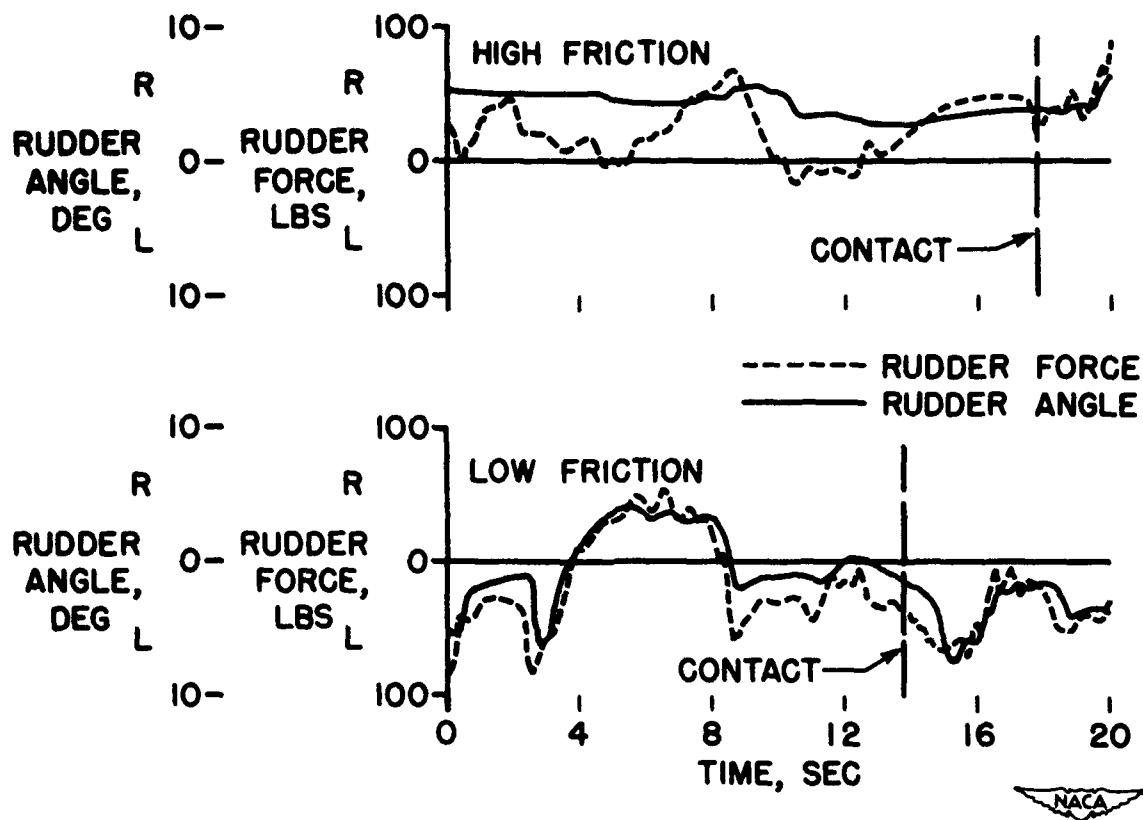

Figure 3. - Time history of two landings of a transport airplane - one with high friction in the controls and the other with low friction.

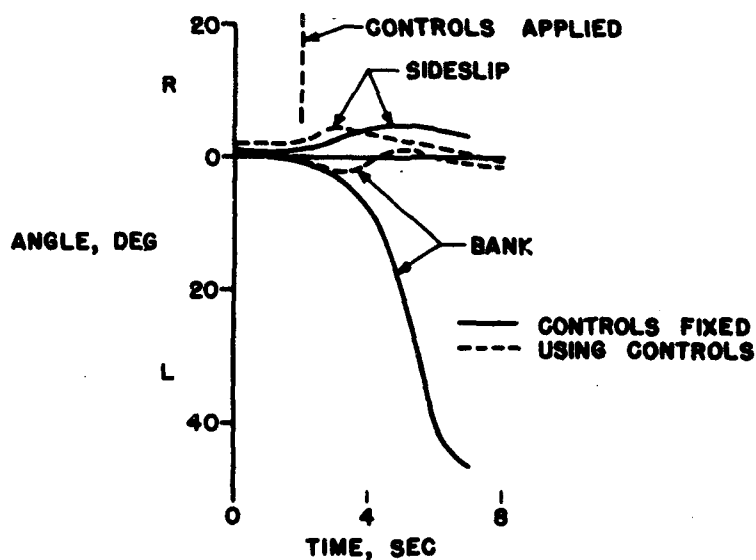

Figure 4. - Time history of the angle of bank and sideslip following failure of the number one engine of a 4-engine transport airplane.

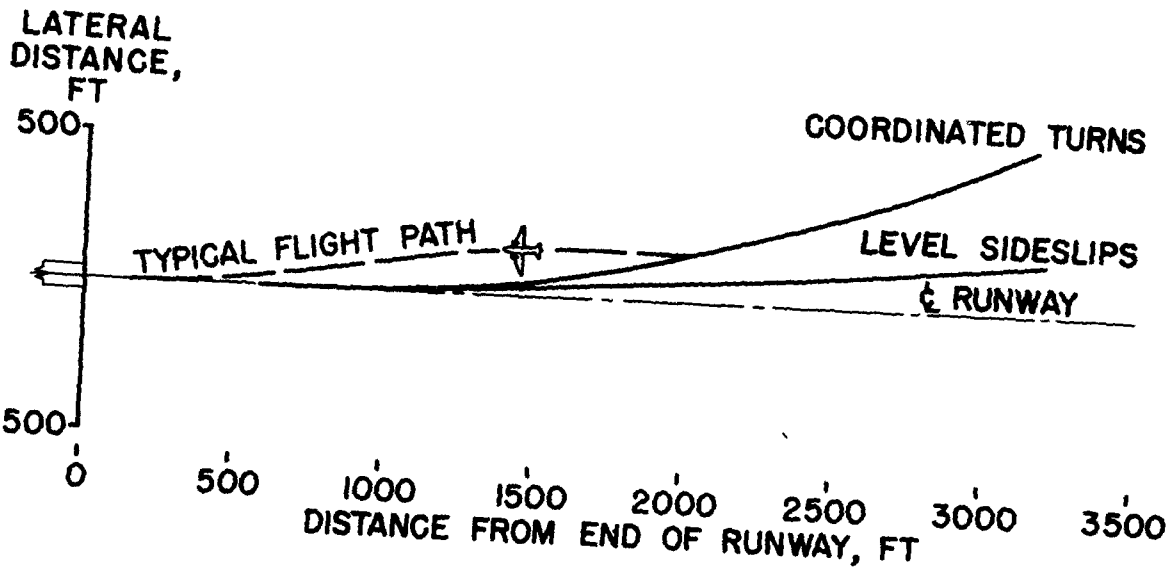

Figure 5. - Locus of starting points of two maneuvers made to laterally displace an airplane during a landing approach.

15. A STUDY OF REQUIREMENTS FOR POWER-OPERATED CONTROLS

AND MECHANICAL FEEL DEVICES

By B. Porter Brown

AERODYNAMIC CONSIDERATIONS FOR HIGH-SPEED TRANSPORT AIRPLANES

15. A STUDY OF REQUIREMENTS FOR POWER-OPERATED CONTROLS
AND MECHANICAL FEEL DEVICES

By B. Porter Brown

Langley Aeronautical Laboratory

Large control forces are necessary in operating many current airplanes because of recent increases in size, maneuverability, and speed. Some designers have already incorporated power-operated control systems as a means of reducing pilot exertion. The basic purpose of any power-operated control system is to supply a large force to the control surface when a relatively small force is applied by the pilot to the booster. Various types of boosters such as electrical, hydraulic, and pneumatic have been designed, with hydraulic systems being the most commonly used.

A test booster of the hydraulic type has been investigated by the NACA. It was installed in the elevator control system of a large four-engined airplane weighing about 110,000 pounds. This booster was adjustable in flight so that the total control effort could be distributed in any proportion between the pilot and the booster. The tests were organized to investigate three major problems connected with boosters: (1) the amount of control effort that should be left to the pilot to obtain best airplane handling qualities, (2) the speed with which a booster should control a surface in order to avoid objectionable lag in airplane response, and (3) the allowable limit of friction in the booster valve.

The first problem is illustrated in figure 1, in which the maneuvering-stability parameter, stick force per g, is plotted against indicated airspeed. The area between the two dashed horizontal lines represents the range of stick force per g for large airplanes considered satisfactory by the military services. Curve A, obtained for the test airplane without boost, shows the stick forces were much larger than those considered satisfactory. These heavy stick forces are typical of nearly all large airplanes without boosters. Actually there has been very little flight experience in the satisfactory range. When the booster in the test airplane was adjusted to give values shown by curve B, all of the pilots noted a marked improvement in their ability to handle the airplane. Adjustment of the booster to give a variation as shown by curve C gave no objectionable characteristics but the pilots felt that this was not as desirable as the

B setting. When the stick force per g was adjusted to vary as curve D, the pilots felt that the forces were too light and this lightness resulted in over-controlling of the airplane. Of the three gradients tested, the pilots preferred the B setting, felt that the C setting was acceptable, and considered setting D unsatisfactory. These results indicate that the lower limit of the specified range could be lowered slightly. It should be noted that the foregoing observations are based only on flying qualities with no consideration being given to the possibility that light forces might lead to inadvertent excessive accelerations being occasionally applied to the airplane.

Appreciation of what correct control forces mean to the pilot is readily obtained by comparing the control forces experienced in a landing without boost and a landing in which the pilot's force was adjusted to fall along curve C. In the landing without boost, the pilot exerted about 80 pounds force just before ground contact. This force is large enough to be annoying to the pilot especially if one hand is adjusting throttles or trim tabs. With boost, however, this force was reduced to about 15 pounds.

The second problem, proper rate of control motion, will now be discussed. The rate of motion required is of major concern to the designer because low rates mean less powerful and therefore lighter boosters. The booster tested was capable of producing a very high maximum rate of elevator motion, about 100 degrees per second, but could also be adjusted for any lower rate. For this investigation, the data were obtained in landings because the rate of elevator motion is critical in this maneuver.

The history of a landing made with unrestricted maximum rate of control motion is shown in figure 2, in which control position and elevator rate are plotted against time. There are two curves shown, a dashed one representing the control position called for by pilot action and a solid one representing actual control position. These curves nearly coincide which means the control was positioned very accurately with no perceptible lag. The curve shows that the highest rate used by the pilot was about 30 degrees per second, a typical value for this airplane. Demands for such high rates are, however, of extremely short duration. Since the airplane cannot respond in attitude appreciably in these short times, good landings may be possible with a much lower maximum rate of control motion. Such a case is indicated in figure X,3 in which the maximum available control rate was restricted to slightly less than 10 degrees per second. In spite of the restricted control rate, the pilot could still move the stick as fast as he wished up to a limit where the error between the

stick position and control surface position was a certain value. Occasionally the pilot called for rates higher than that available as shown by the flat spots, and this excessive demand caused some lag in positioning of the control. Because the demands for the higher rates were very brief, however, this lag never got large enough to be objectionable to the pilot. Consequently, the pilots thought the airplane handled just as well with the restricted rate as with the unrestricted rate.

This result indicates that for large airplanes, satisfactory handling qualities can be obtained with boosters having maximum available elevator-control rates less than that used in the unrestricted case. Of course, the conclusion that a rate of about 10 degrees per second is satisfactory applies only to the elevators on large airplanes. Higher rates may be required on other controls or on smaller airplanes.

The third problem, allowable limit of friction in the booster valve, will be discussed next. It should be pointed out that the friction considered in these tests was the friction in the booster control valve and not the friction in the normal control system. A schematic drawing of a boost system (fig. 4) indicates the normal operation of the system and the effect of friction in the control valve. The arrows show the direction of fluid flow to and from the booster valve. During steady flight of the airplane the control surface is held fixed by the piston, which has fluid on each side and is in equilibrium. If the pilot pulls back on the stick, the vertical link attached to the stick rotates to a new position because its lower end is restrained by the link connected to the control surface. Motion of the upper horizontal link to its new position opens the booster control valve, allowing fluid to go into the jack. This induction of fluid moves the piston in such a direction as to pull the elevator up. The upward motion of the elevator actuates the lower horizontal link which then rotates the first link about the pivot point in its center because the pilot is holding the stick fixed. This rotation moves the link back to vertical again, closing the valve and stopping the flow of fluid and thereby establishing a new equilibrium position of the hydraulic jack. If friction were present in the valve, it would tend to hold the valve open at the end of the operation thereby allowing fluid to continue to flow into the jack and move the elevator until the pilot applied corrective action by moving the stick in the opposite direction. This friction effect differs from the effect of conventional control friction in that the valve friction tends to keep the elevator in motion while ordinary static friction tends to prevent the elevator from moving. It had been suspected that friction of this type, even in small amounts, would be highly objectionable to pilots.

Tests were therefore made with several known values of booster-valve friction that were intentionally introduced into the system. One part of the tests consisted of steady runs in which the pilot attempted to maintain a given speed. Data from two of these steady runs are presented in figure 5. Each curve shows normal acceleration plotted against time. The upper curve is for negligible valve friction and the lower one is for a valve friction value of $1\text{-}1/2$ pounds of pilot's stick force. Comparison of the peaks of acceleration experienced makes the flying difficulty caused by valve friction quite obvious. Some landings were also made with different amounts of friction and it was noted that here also corrective control was applied more frequently as a result of this friction. In all of the test maneuvers the pilots felt that any amount of friction was annoying because it resulted in continual overcontrolling. The results of these tests indicate that the allowable limit of this type of friction is much lower than the 8-pound limit of normal elevator control friction of the type which tends to hold the control fixed and extreme care should be taken in the design of any powered control system of this type in order to eliminate as much friction as possible in the booster control valve.

All of the tests discussed thus far were made with the booster allowing a portion of the elevator-hinge moments to be fed back to the pilot's stick to provide the necessary control feel forces. High-Mach-number effects cause undesirable hinge-moment variations, however, making it very difficult if not impossible to balance the control surface aerodynamically. Boosters alone in this case can not alleviate the problem. A much simpler approach to the problem is, however, quite apparent. If the booster were designed to allow no force feed back from the elevators and another device were included to create the feel forces mechanically, then the problem of undesirable hinge-moment characteristics would be eliminated.

Some present-day high-speed airplanes are equipped with feel devices but as yet transport airplanes do not need them because they are operated at relatively low Mach numbers. In jet-transport design, however, feel devices will probably be employed.

The NACA has made tests on a feel device to gain experience with this type of control system and to investigate the design features that should be incorporated in such devices.

With the aid of figure 6, the component parts of the test feel device and their functions will be explained and compared to the similar parts and functions in a conventional control system.

In the actual test installation there was a link not shown in figure 6 that connected the pilot's stick to the booster and of course the booster was connected to the control surface. These linkages were omitted from the figure because the tests were concerned only with stick forces and the booster purposely eliminated all aerodynamic stick forces; therefore the drawing represents the complete unit as far as pilot's force is concerned.

In a conventional control system, when the surface is deflected, hinge moments are created that tend to restore the surface back to neutral and hence supply the pilot with a control force. This restoring tendency increases as the square of the speed. In the feel device system, the restoring tendency is supplied by the spring connected to the trimmer and to a variable lever arm, which is so adjusted by dynamic pressure, as to make the restoring tendency in the system increase as the square of the speed. In the conventional system, if the pilot wishes to change airplane attitude by use of elevator deflection, the new attitude is maintained with zero pilot's force by use of a trim tab. In the feel device, this is accomplished by means of the trimming device shown. The part to which the spring is secured is really a movable base that the pilot can move in either direction to relieve the tension or compression in the spring and thereby establish a new zero-force stick position. The variable lever arm controlled by the manual force gradient adjuster has no comparable part in the conventional control system. The only reason it was included in this design was to provide a convenient way by which the control force gradient could be varied. In the conventional system, damping is supplied aerodynamically while in this system, it is supplied by the viscous damper attached to the pilot's stick.

This feel device was installed in an airplane in conjunction with the previously mentioned booster in the elevator-control system. As previously mentioned, the booster could be adjusted to allow any portion of the elevator hinge moments to be fed back to the pilot and for these tests the booster was adjusted to allow no force feed back from the elevators.

Static and maneuvering longitudinal stability tests on the airplane were made with the feel device and without the feel device for comparison purposes. Figure 7 shows two flight records of normal acceleration that were obtained in pull-ups and releases to determine if the device introduced any oscillating tendencies into the system. The upper curve is for the case without the feel device while the lower one is with the feel device. The only portion of these curves of interest to this analysis is the part following the time at which the pilot released the stick, shown by the vertical lines, which occurred in these two cases at approximately 2 seconds. Comparison

of the two curves beyond this point in the two records indicates that the device did not introduce any undesirable oscillating tendencies. Data obtained in static longitudinal stability runs are presented in figure 8. Pilot's force is plotted against indicated airspeed for the two cases with and without the feel device. In this type of plot a pull force should be required to decrease airspeed in order for the airplane to be stable. The point emphasized in this figure is that the feel device did not alter any of the characteristics of the airplane except the magnitudes of the control forces. This can be pointed out by the fact that at the higher speeds both curves indicate that the airplane was stable down to a speed of about 160 miles per hour. At this speed, however, the slopes of both curves reverse, indicating instability. This instability in the stick forces occurred in both cases because the elevator angle variation was unstable. This characteristic demonstrates that if the variation of elevator angle with speed is unsatisfactory, the feel device cannot provide completely satisfactory stick forces. In the case in which elevator deflection does vary satisfactorily, however, either with speed or acceleration, even though the aerodynamic hinge-moment variation may be undesirable, the feel device will provide satisfactory control forces. This point is illustrated in figure 9.

Maneuvering stability data are presented in figure 9 to compare cases with and without the feel device for a condition at which the elevator angle variation with acceleration was satisfactory but the aerodynamic hinge-moments were unsatisfactory. Pilot's stick force is plotted against normal acceleration. In a plot of this type, satisfactory characteristics are recognized by the fact that pull forces should be required to produce positive accelerations and push forces are required to produce negative accelerations. In the case without the feel device, shown by the solid line, the force characteristics were satisfactory at high normal accelerations, but at low normal accelerations elevator overbalance was encountered, which indicates unsatisfactory forces, because eventually, pull forces were required to produce negative accelerations. The dotted line shows the performance of the feel device under similar conditions and it is obvious that the overbalance is completely eliminated because the forces are always in the right direction. The forces furnished by the feel device in this case were satisfactory because the variation of elevator angle with acceleration was satisfactory.

In summary, it should be remembered that both the booster system and the mechanical feel device have been evaluated with no considerations being given to such things as reliability, mechanical failure, or weight. The booster tests, however, provide design information on the control effort that should be left to the pilot. The results also

show that the rate of elevator motion to be supplied by the booster can be limited to values lower than those normally used by pilots. In addition, friction in the booster control valve deserves careful design attention. The feel device investigation indicated the device to be satisfactory and, in addition to providing valuable experience with this type of control system, the tests showed several features that would be desirable in these systems.

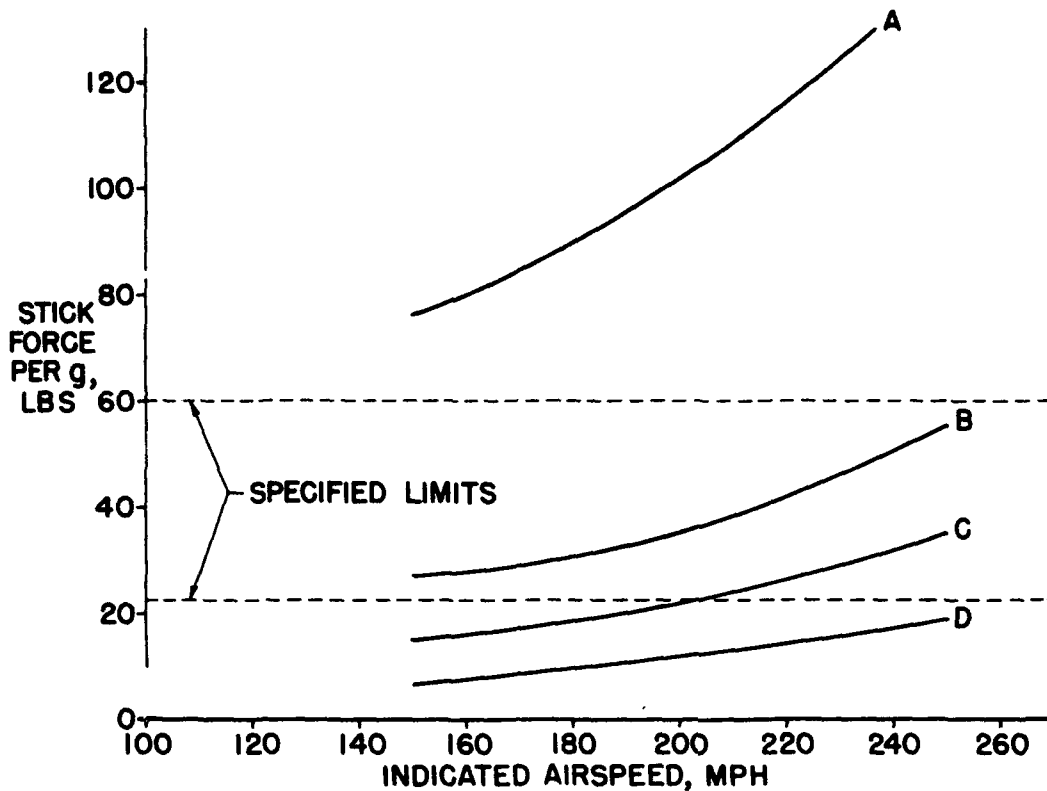

Figure 1. - Stick force per g versus indicated airspeed for test airplane without boost and for three gradients supplied by booster. Shows satisfactory range specified by military services.

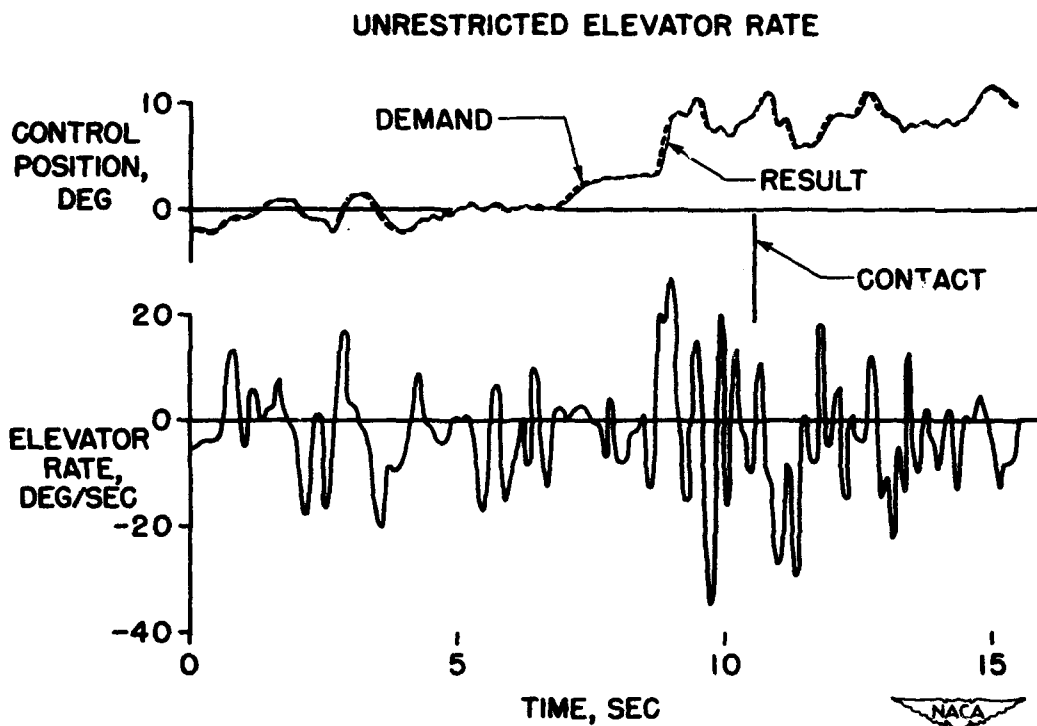

Figure 2. - Time history of a landing made with an unrestricted elevator rate.

RESTRICTED ELEVATOR RATE

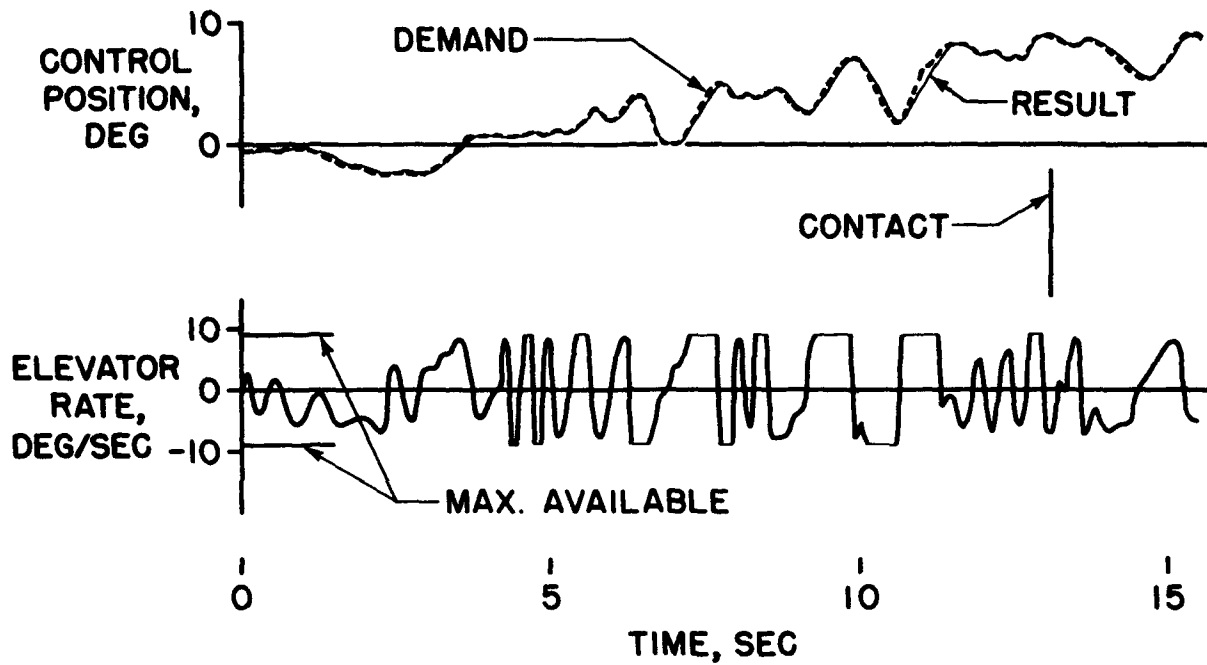

Figure 3. - Time history of a landing made with restricted elevator rate.

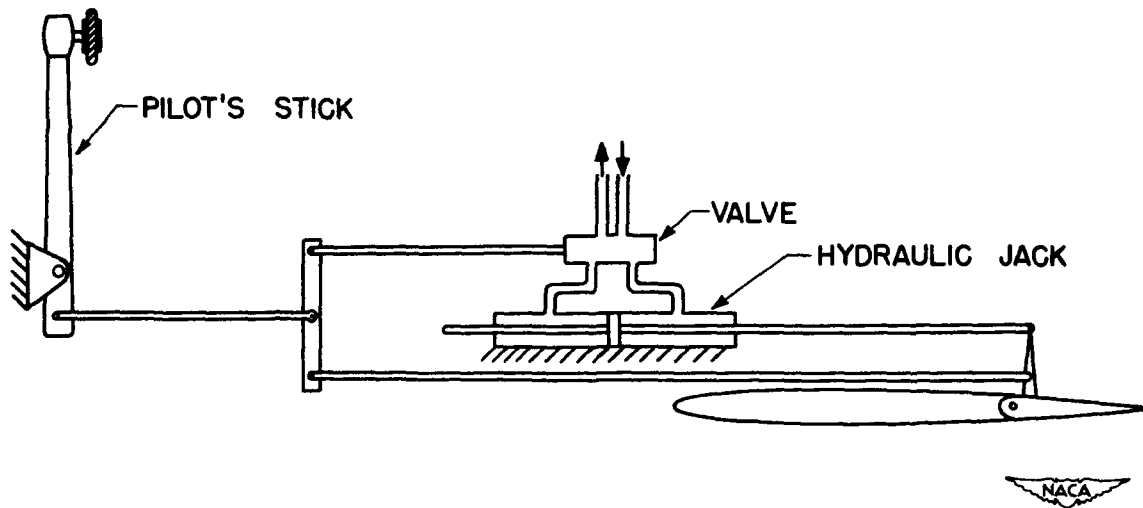

Figure 4. - Schematic drawing of the boost system.

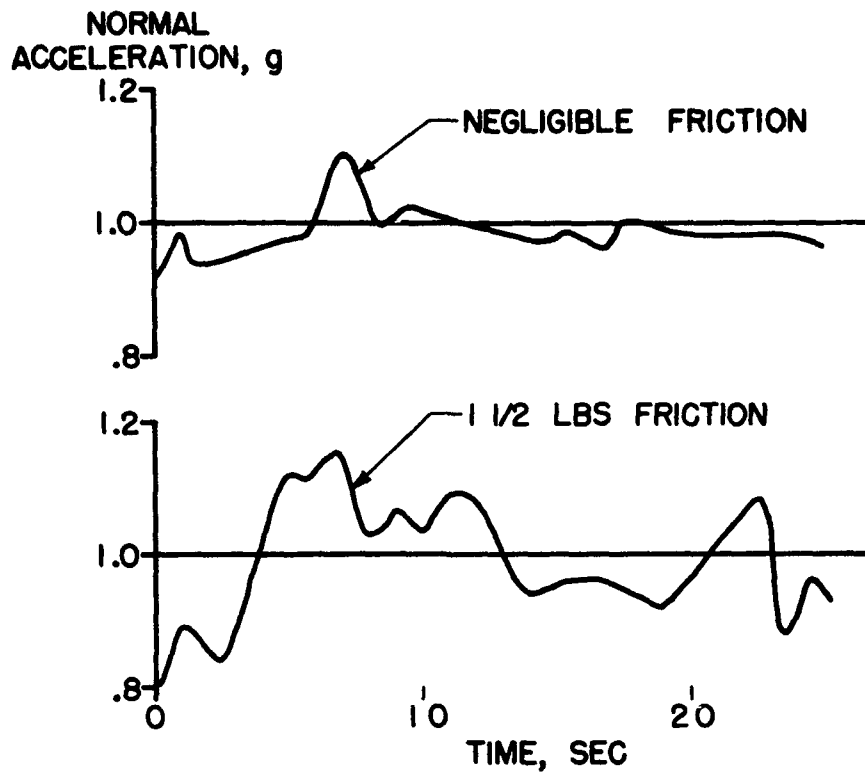

Figure 5. - Time histories of normal acceleration for two values of booster valve friction.

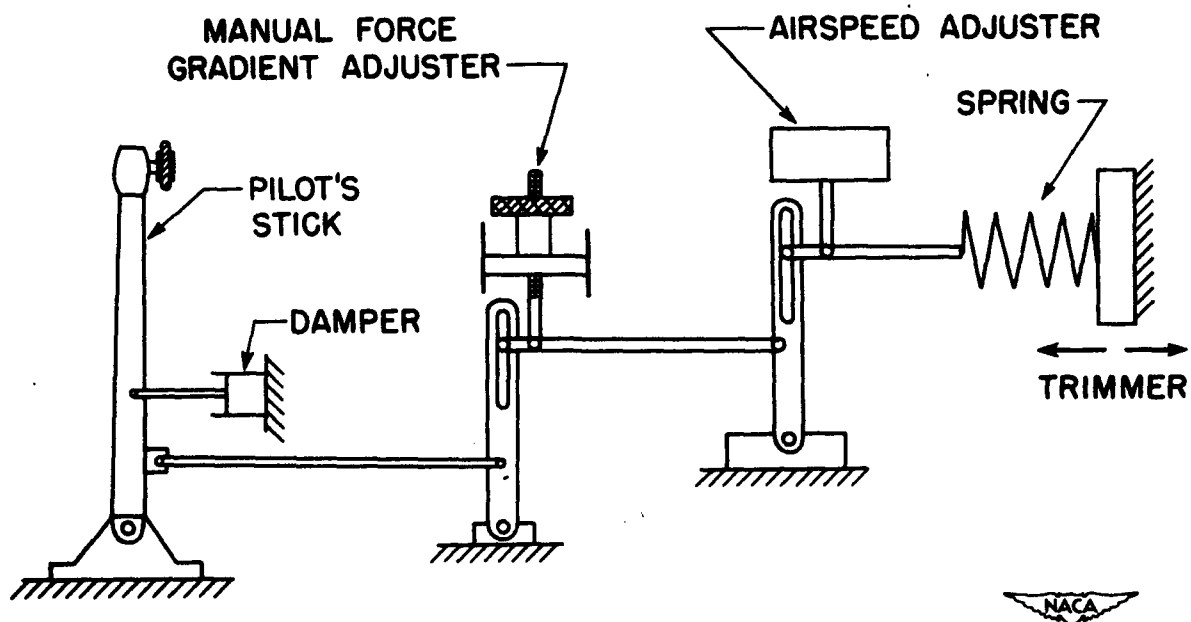

Figure 6. - Schematic drawing of feel device.



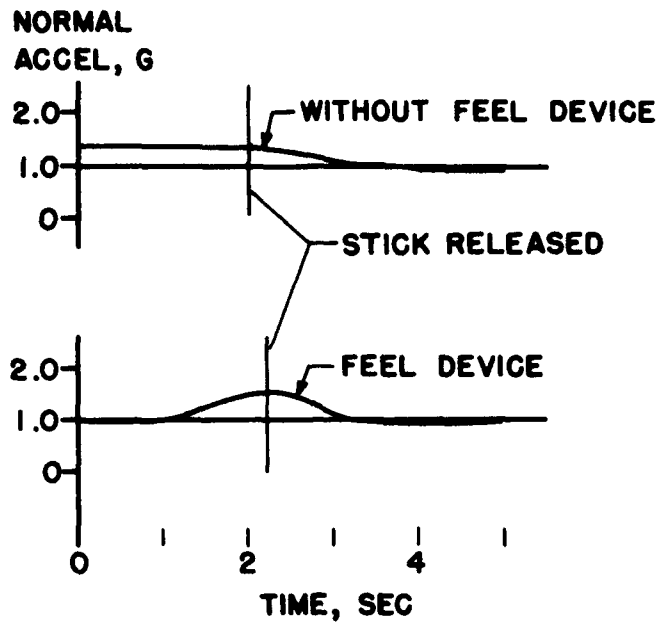

Figure 7. - Dynamic stability runs of normal acceleration with and without the feel device.

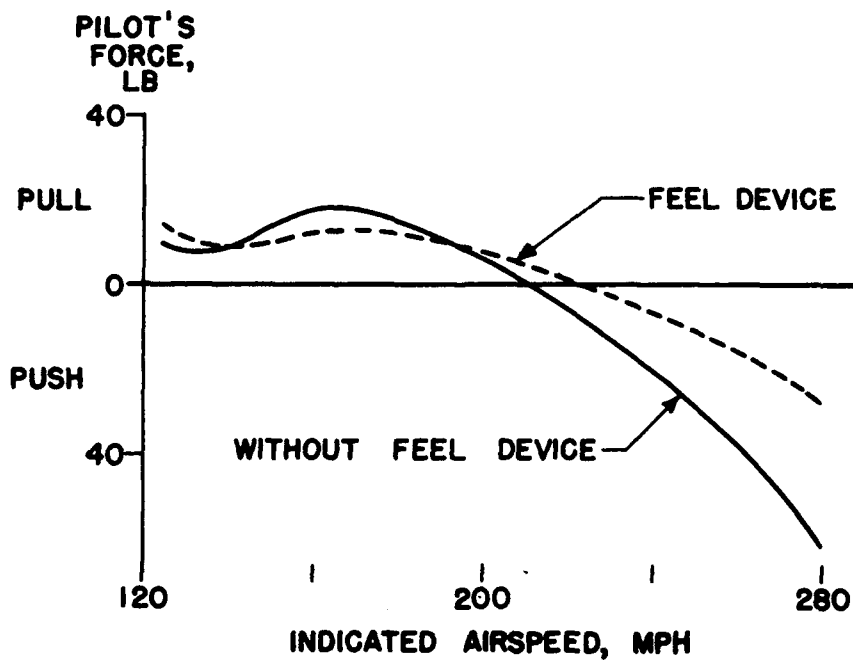

Figure 8. - Pilot's stick force versus indicated airspeed with and without the feel device.



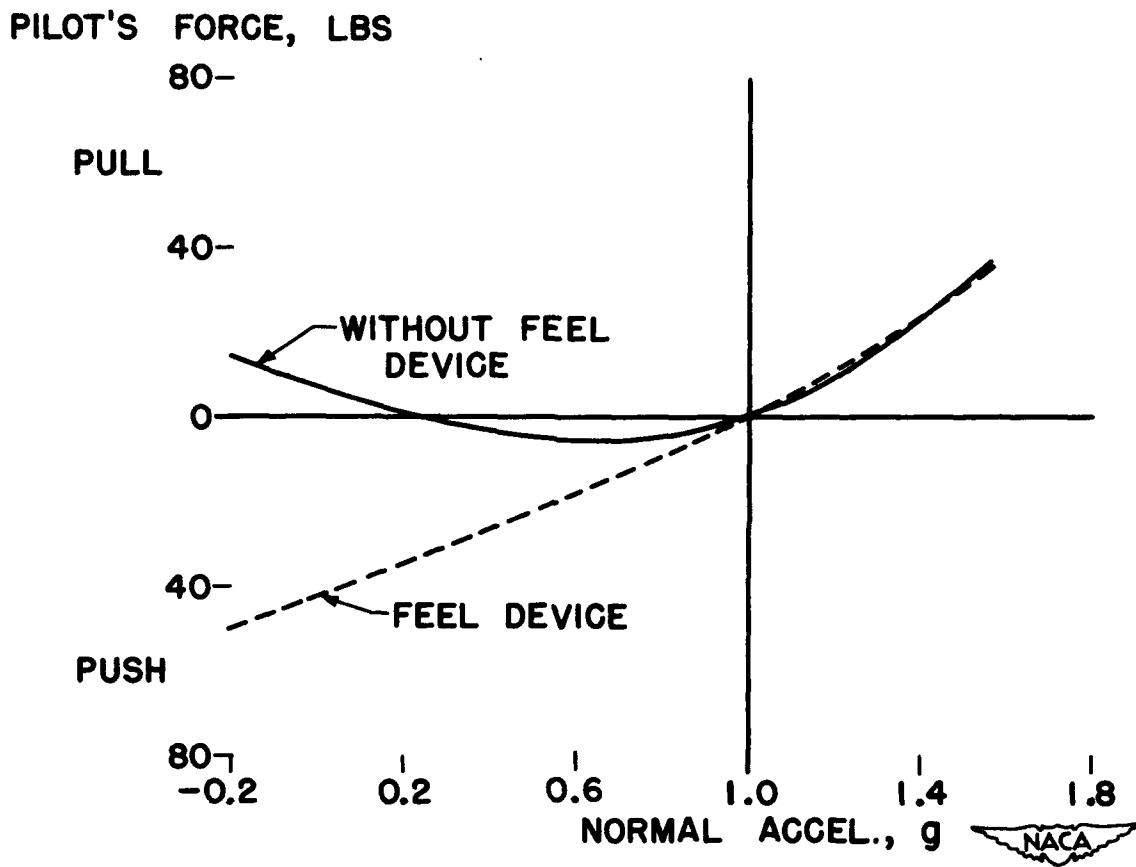

Figure 9. - Pilot's stick force versus normal acceleration with and without feel device.

RESTRICTED

PROPULSION CONSIDERATIONS FOR HIGH-SPEED TRANSPORT AIRPLANES

RESTRICTED

16. SOME CONSIDERATIONS OF AIRCRAFT NOISE

By Harvey H. Hubbard

PROPULSION CONSIDERATIONS FOR HIGH-SPEED TRANSPORT AIRPLANES

16. SOME CONSIDERATIONS OF AIRCRAFT NOISE

By Harvey H. Hubbard

Langley Aeronautical Laboratory

Studies of aircraft noise are complex and have a great many ramifications. In addition to the well known nuisance aspects a person may suffer temporary deafness, communications of all kinds may be disrupted, and various electronic devices may be caused to malfunction.

In the propeller, the reciprocating engine, and the turbojet engine, the aircraft industry has some of the most prolific noise generators the world has known. In addition to these accessories the airframe itself is a source of noise as it moves through the air.

It is the purpose of this paper to introduce and to indicate the scope of some of the aircraft noise problems. Brief reviews of research in regard to the various phases of the problem will be treated in the following order; propeller noise, engine-exhaust noise and muffling, and jet-engine noise. Since a portion of this research was accomplished by persons not connected with the NACA, I wish to acknowledge contributions from the work of Dr. Horace O. Parrack, Mr. Kenneth R. Jackman, and various groups at the Bell Telephone Laboratories, and the Aeronautical Research Foundation. Figure 1 (reference 1) illustrates the ranges of frequency and intensity concerned in this paper. The horizontal scale is frequency in cycles per second. The vertical scale is in decibels, where a decibel is a convenient logarithmic unit of sound intensity. The shaded portion indicates the frequencies and corresponding intensities necessary for normal speech. Experiments at the Bell Telephone Laboratories (reference 2) have shown that the ear does not respond equally well to sounds of all frequencies and intensities. This non-linear response of the ear is not a function of intensity or frequency alone but depends on both of these together. The ear is most sensitive to frequencies in the order of 1000 cycles per second and the sensitivity drops off for the region of low frequencies and intensities. Normally, for aircraft noise, advantage can not be taken of this phenomenon because the associated intensities are so great as to be in the range where the response of the ear is flat. It is only after some reduction of the intensities has taken place or unless the observer is at a great distance from the

source that much benefit can be derived at the low frequencies from the frequency response of the ear. It was also found at the Bell Telephone Laboratories that a low frequency was effective in masking any higher frequency. Because of this phenomenon communications and speech are very difficult in the presence of a low frequency background noise.

Thus, figure 1 suggests that as the intensities of the low frequencies are increased, communications are probably the first to be affected. Many scientists think that a person may be continuously exposed to levels of 85 decibels, as indicated by the dotted line without any lasting ill effects and the Air Force has adopted this level in order to standardize its facilities. At levels above this a person will experience more and more discomfort until pain or physical damage is experienced. It is quite generally agreed that persons should not be required to withstand intensities above 120 decibels and for conditions involving long-term exposures the limit is probably in the order of 85 decibels or below.

Since it is well known that noises are less intense as the distance from the source is increased, it is of interest to evaluate this effect of distance on aircraft noise. Figure 2 is a plot of the reduction in decibels as a function of distance in feet for various frequencies in the audible range (reference 3). The solid curve is an indication of the reduction in intensity due to the spreading of the wave as distance increases. Due to this phenomenon which holds true for no atmospheric losses there is a decrease of sound intensity of 20 decibels each time the distance is increased ten fold. The dashed curves indicate the amount of measured reduction as a function of distance that is obtained for various frequencies. The difference between the solid and dashed curves is the atmospheric attenuation, where atmospheric attenuation is reduction in intensity due to conversion of the sound energy to heat energy by viscosity, conduction, water vapor, etc. For a frequency of 10,000 cycles per second which is near the limit of the audible range, there is considerable attenuation at 1000 feet while for frequencies of 1000 cycles per second or less there is a negligible amount even at 10,000 feet. Sound measurements on an A1-6 airplane in flight fell near the sound curve, thus indicating that for that particular configuration little or no atmospheric attenuation was present. Thus, it is seen that for high frequencies or large distances the atmospheric attenuation may be appreciable while for low frequencies or small distances it is negligible.

Since it is seen that not much benefit is derived by the sound reduction characteristics of the human ear and of the atmosphere it is necessary to turn to other and more effective means. Sound reduction is usually accomplished in two general ways. One of these is to reduce the sound at the source and the other is the enclosing by means of a suitable structure of either the sound source or those persons to be protected. Both methods of sound reduction are important and are probably most effective when used to complement each other.

The amounts of reduction available from various schemes of sound proofing are dependent to a large extent on the frequency of the impinging sound. Figure 3 illustrates the amount of noise reduction obtainable in an airplane fuselage by use of some of the sound proofing techniques in common use today. Decibels of reduction are plotted as a function of frequency. The curve represents the amount of reduction obtained at various frequencies by the addition of trim cloth, carpeting, and absorbing material such as glass wool over that obtained with the bare fuselage (reference 4). These results indicate that at frequencies in the order of 1000 cycles per second and above, considerable reduction may be obtained by use of standard sound proofing techniques. At lower frequencies the reductions obtainable are relatively small.

Now that there is an evaluation of some sound proofing techniques that may be used to reduce the noise after it has been generated it is appropriate to investigate the significant parameters in noise generation to determine what may be done to reduce the various noise components at the source, and especially the lower frequencies that are most difficult to reduce by other means. Any reduction obtained at the source is important because it benefits the persons on the ground as well as those in the airplane.

Figure 4 is a polar diagram showing the two sources of noise from a propeller and gives an indication of the relative intensities and directional characteristics of each for a typical present-day configuration (reference 5). The rotational noise which is a function of the forces on the blades is seen to have greater intensity than the vortex noise which is associated with the turbulent wake of the blades. Both sources radiate noise in a directional manner. The rotational noise is more intense near the plane of rotation and is weakest on the axis of rotation. The reverse is true of the vortex noise. The frequency spectrum of the rotational noise consists of discrete frequencies which are multiples of the blade-passage frequency. The frequencies then are determined by the rotational speed and the number of blades. For tip Mach numbers up to 0.90 the fundamental frequency is usually the most intense. At supersonic tip speeds some of the higher harmonics become predominant. Vortex noise consists of a wide band of random frequencies extending from some low value to several thousand cycles per second. In reducing propeller noise the rotational noise is first reduced since it is predominant. Procedures for reducing the rotational noise will usually also reduce the vortex noise but at a slower rate. Thus for quiet propellers the vortex component may be a large part of the total.

Two effective ways in which propeller noise may be reduced are shown in figure 5 where the sound intensities are plotted as a function of the tip Mach number at constant power for a two- and a six-blade single-rotation propeller. It should be noted that the tip Mach number rather than the rpm is a significant parameter in noise generation. It is apparent from the figure that intensities generated by the six-blade propeller are lower than those for the two-blade propeller at all tip

Mach numbers even though at supersonic tip Mach numbers these differences are relatively small. It can be seen then that an increase in the number of blades is always beneficial in reducing the noise produced.

Another very effective way in which propeller noise may be reduced is to lower the tip Mach number. Figure 5 shows that the noise intensities reduce at a rapid rate as tip Mach number is reduced.

In practice it follows that if a larger number of blades is used the tip Mach number may be lowered because of the additional blade area available. Points "A" and "B" represent two typical operating conditions where the same power is absorbed by these two propellers at different tip Mach numbers. The reduction of approximately 30 decibels thus obtained illustrates the benefits available from multiblade propellers.

Figure 5 also permits comparison of supersonic propellers with conventional ones in regard to noise generation. Noise levels are seen to be very high and since by definition the tip Mach numbers for operation are above unity, ways of noise reduction are greatly limited.

In the oscillating pressure field surrounding a propeller, the intensity depends on the distance from the source. At points away from the propeller these oscillating pressures are recognized only as noise. At points in close proximity to the propeller they produce intense noise and are also capable of exciting destructive vibrations in nearby aircraft structures (reference 6). The frequencies of these pressures are a function of the rotational speed of the propeller and the number of blades.

The study of these intense oscillating pressure fields and their associated vibrations is of interest as an important related subject. Figure 6 illustrates schematically some typical pressure measurements near the propeller where the points of measurement are indicated by the check marks. Flow through the propeller disk is from top to bottom. The pressure distributions ahead of the propeller in the region where a wing might be located are shown in the top-most shaded area. The maximum pressures were measured near the $3/4$ station of the blades. These pressures under certain conditions may have caused failures of the secondary structure of the wing. The shaded portion on the left indicates the pressure distribution in the region where a fuselage might be located. The peak pressures occur near the plane of rotation. These pressures under certain conditions have caused failures of some parts of the fuselage wall structure. In general, procedures for reducing the propeller noise will also be beneficial in reducing the propeller-excited vibrations. An increase in the clearances between the propeller and the wing and fuselage is especially beneficial in reducing the effects of these pressures.

Since reciprocating engines are still very much in the picture for aircraft propulsion it is of interest to investigate the characteristics of exhaust noise from this type of engine. The solid curve of figure 7 shows schematically the composition of a typical exhaust noise spectrum

where intensity is plotted as a function of frequency. The fundamental firing frequency is the strongest one present and the intensities of the higher order frequencies are considerably lower in amplitude. Some confusion exists as to which frequencies should be reduced. The task of reducing the overall exhaust noise is apparently one of reducing the low frequency components since they are of greatest strength, however, some observers feel that the higher order frequencies are most objectionable.

For any given engine we can look to the exhaust muffler as a means of reducing this exhaust noise. A very simple muffler design for small personal-owner-type aircraft is illustrated in figure 7. The exhaust gases pass straight through the central pipe to eliminate excessive engine back pressures. A chamber is built around this central pipe in such a way that it will store up energy at the peak of a pressure wave and return the energy at a trough of the wave, thus tending to smooth out the pressure pulses and reduce the oscillating pressures.

The effectiveness of this muffler is shown on the figure where the space between the curves represents noise reduction. Even though a muffler may be designed to provide greatest reduction at a given frequency it can also provide considerable reduction for a band of frequencies on each side of the design point. Hence in this case where the design is near 250 cps it will provide some reduction for both the higher and lower frequencies in order to bring them down to some desired level. From the standpoint of muffler design it is beneficial to keep the firing frequency as high as possible since that tends to keep down the size and weight of the muffler.

To this point methods have been shown by which propeller noise and engine exhaust noise may be reduced. In an effort to determine the practicability of applying these schemes, the NACA in 1948 modified a small airplane to reduce the noise reaching the ground (references 7 and 8). The results of this experiment and other subsequent research at the Aeronautical Research Foundation (reference 9) indicated that by known methods of noise reduction a personal-owner-type aircraft may be made quiet, perhaps more so than necessary.

Following successful noise-reduction tests with the small airplane it was thought advisable by the NACA to make a preliminary study of modifications required to the propeller and engine exhaust system for a large transport-type aircraft. The type of modifications that were estimated, based on an extrapolation of data for small airplanes are those shown in figure 8. If the number of blades were increased from 3 to 6 while holding diameter constant and the rotational speed was reduced from 1400 to 650 rpm it was estimated that the propeller noise could be reduced by about 25 db. It should be noted that the proposed modification would require a change in the gear ratio. It is estimated that with the modified propeller the take-off and climb performance will be reduced slightly but cruise performance would be comparable. It is of interest that propellers designed to operate at low rotational speeds to

delay compressibility losses appear to be the optimum design aerodynamically for speeds in the 450 - 550 mph range. Hence the sound requirements and aerodynamic requirements of propellers for transport type aircraft appear to be in harmony.

Estimates of the exhaust noise level of the R-2800 engine indicated the need for a 20-decibel reduction in the overall noise level. The sketch of figure 8 shows the type and size of muffler estimated to accomplish this result. This design embodies the results of research on light airplane mufflers and a limited number of cold air tests. The design is a multi-chamber resonator with an elliptical cross section. It was thought that it would fair into the region in the top of the nacelle behind the carburetor air intake scoop in a manner shown by the sketch where the shaded portion indicates the path of the exhaust gases. This installation was designed to reduce the noise reaching the ground. Modifications of present-day aircraft to incorporate noise reduction features will probably involve a weight penalty. Hence the gains in comfort and utility must be weighed against losses in performance caused by these modifications.

The turbojet engine is one of the most prolific generators of a random noise spectrum. Figure 9 illustrates two different spectra obtained in open air for the TG-190 engine at take off. Frequency in cps is plotted as a function of decibels at two points in the jet noise field. The solid curve represents data recorded in octave bands at 90° to the jet axis and at a distance of 12 feet. It is seen that there is a large amount of energy present in all the audible range and beyond, to frequencies above the audible range. The dashed curve was recorded at 30° from the axis of the jet and at the same distance from the orifice. This curve shows a much greater concentration of the energy in the frequency range below 1500 cps, but with the intensities falling off rapidly as frequency increases. The noise field is seen to be highly directional, with maximum intensities occurring near the jet. To the person inside the airplane the noise will vary widely according to his position relative to the jet orifice. The main source of jet-engine noise is the jet itself and there is some evidence to indicate that the noise generated decreases with increased forward speed of the airplane. Although the subject of aerodynamic noise is not treated in this paper it is significant to note that at high forward speeds this component may be predominant in the forward compartments of some jet aircraft. Studies are continuing in an attempt to determine the variation of jet noise as a function of various parameters such as thrust, velocity, temperature, etc., before effective noise-reduction techniques may be applied.

Since the turbojet is destined to compete with propellers operating at supersonic tip speeds for propulsion at very high speeds, there is great interest in comparing the noise spectra produced by them. In order to provide such a comparison, curve "A" from figure 9 is replotted on figure 10 along with an estimated frequency spectrum of a propeller operating at a tip Mach number of 1.20 and producing the same thrust at take-off as the turbojet. The data are for comparable distances and positions in the sound fields, for the open-air condition.

We can see that the intensities generated by both are in the range likely to cause great discomfort. The intensities in the low-frequency range are such as to interfere strongly with communications and will be difficult to soundproof against. Maximum intensities generated by the propeller are seen to be in the order of 20 decibels higher than those of the turbojet. The noise levels resulting from the use of propellers operating at supersonic tip speeds are seen to create a serious operating problem.

In summary the following observations may be noted: (1) for flight Mach numbers up to approximately 0.70 it appears that quiet propellers may be used at good aerodynamic efficiency; (2) engine exhaust muffling of small aircraft engines has proven technically feasible and it is thought that the same techniques may be applied to larger engines, and (3) the use of the turbojet engine and propellers operating at supersonic tip speeds will give rise to serious noise reduction problems.

REFERENCES

1. Parrack, Horace O.: Aircraft Noise and Noise Suppression Facilities and Evaluation. Paper presented before Joint Conf. AMC and Aircraft Ind. Assoc. (Los Angeles), April 11-12, 1950.
2. Fletcher, Harvey, and Munson, W.A.: Loudness, Its Definition, Measurement and Calculation. Jour. Acous. Soc. Am., vol. V, no. 2, Oct. 1933, pp. 82-108.
3. Regier, Arthur A.: Effect of Distance on Airplane Noise. NACA TN 1353, 1947.
4. Jackman, Kenneth R.: A Review of Advances in Silencing Aircraft. Paper presented before Semi-Ann. Convention A.S.M.E. (Chicago), June 16, 1947.
5. Hubbard, Harvey H., and Regier, Arthur A.: Propeller-Loudness Charts for Light Airplanes. NACA TN 1358, 1947.
6. Hubbard, Harvey H., and Regier, Arthur A.: Free-Space Oscillating Pressures near the Tips of Rotating Propellers. NACA TN 1870, 1949.
7. Vogeley, A.W.: Sound-Level Measurements of a Light Airplane Modified to Reduce Noise Reaching the Ground. NACA Rep. 926, 1949.
8. Czarnecki, K.R., and Davis, Don D., Jr.: Dynamometer-Stand Investigation of the Muffler used in the Demonstration of Light-Airplane Noise Reduction. NACA TN 1688, 1948.
9. Beranek, Leo L., Elwell, Fred S., Roberts, John P., and Taylor, C. Fayette: Experiments in External Noise Reduction of Light Airplanes. NACA TN 2079, 1950.

NOISE
INTENSITY,
DECIBELS

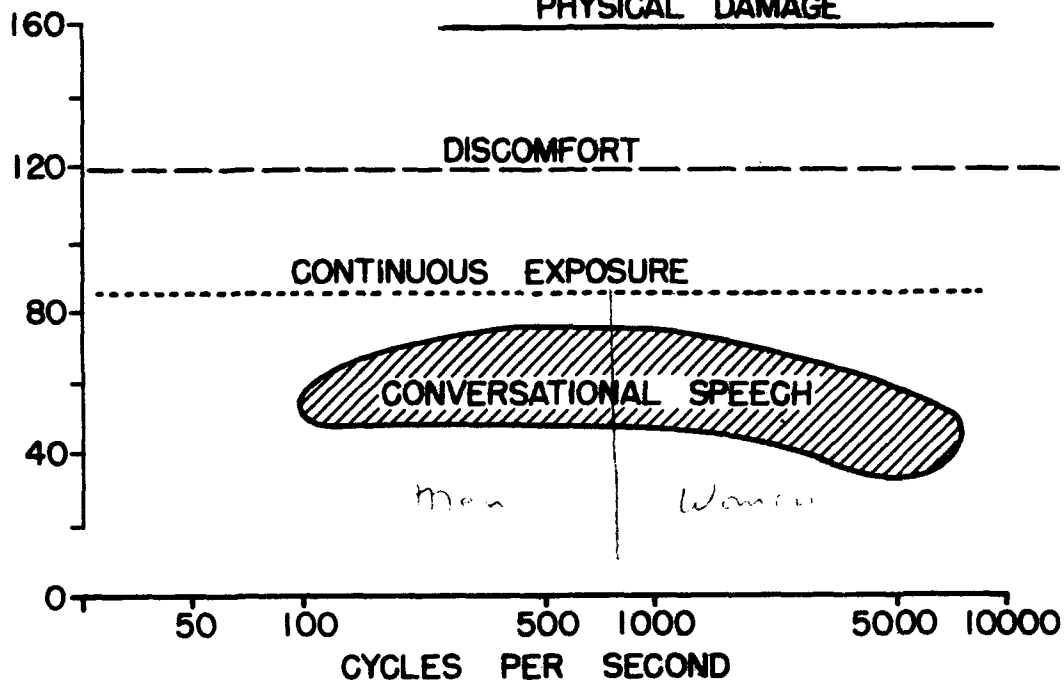

Figure 1. - Frequency and intensity considerations in regard to the hearing mechanism.

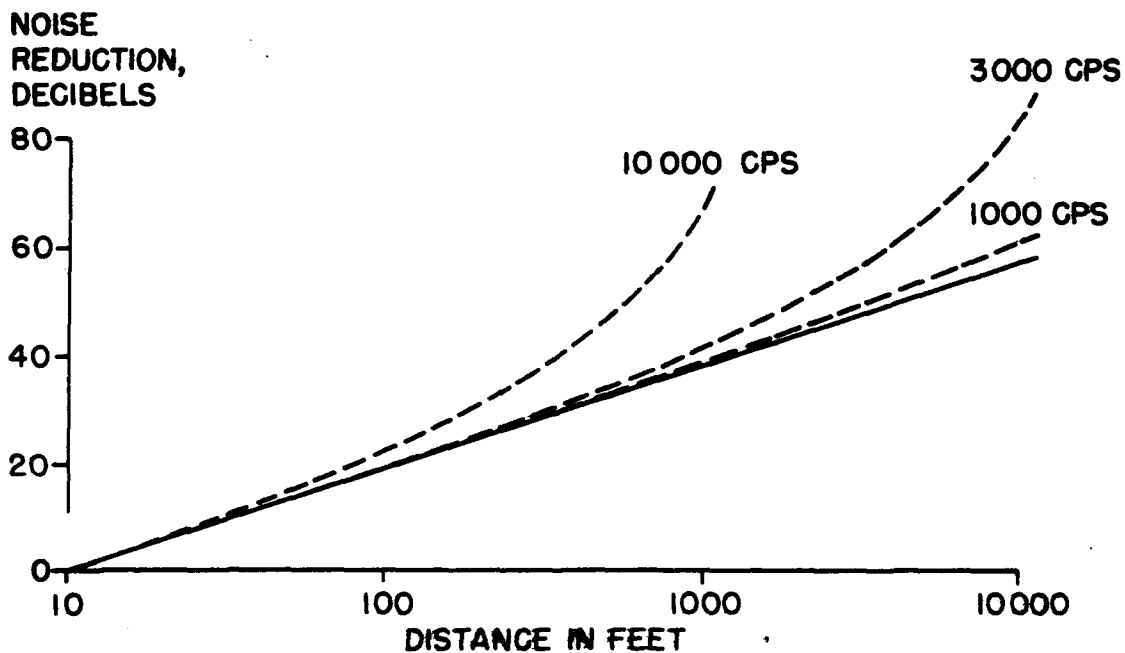

Figure 2. - Noise reduction as a function of distance from the source.

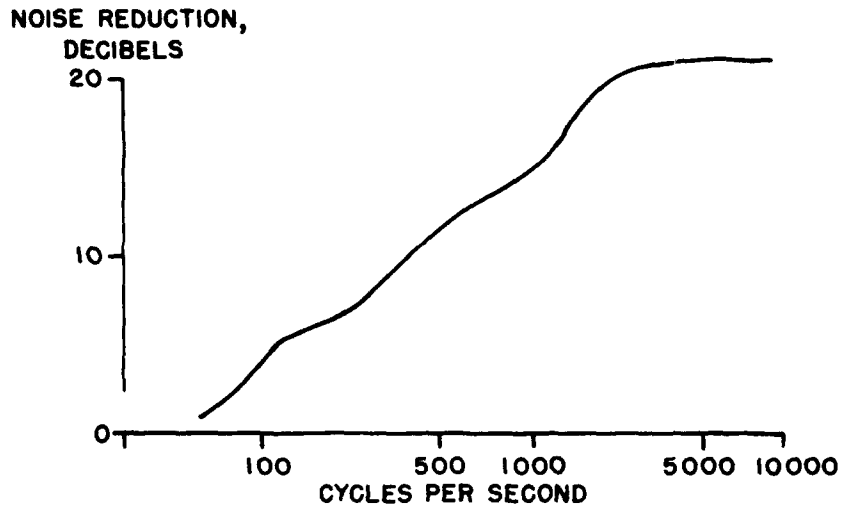

Figure 3. - Noise reduction obtainable in an airplane fuselage by typical sound proofing techniques.

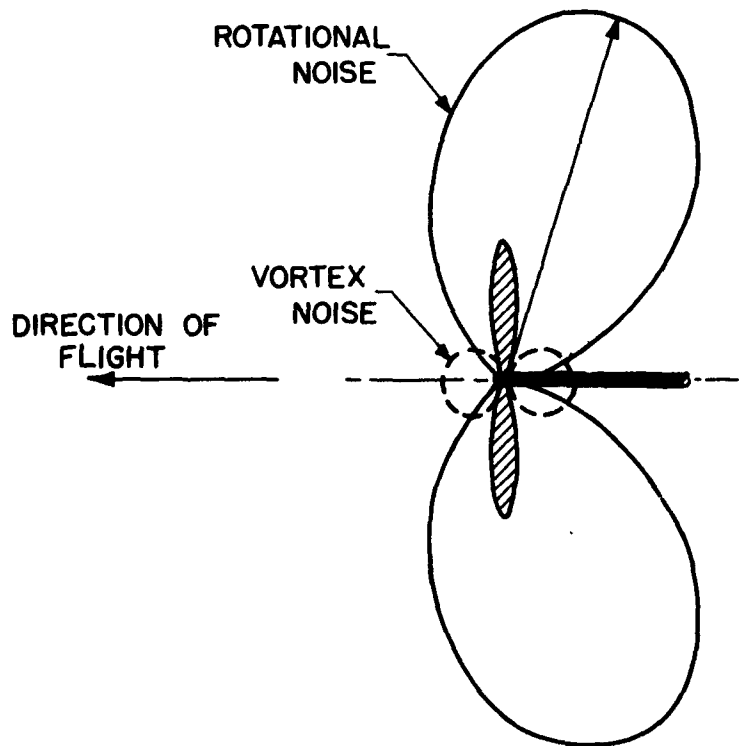

Figure 4. - Polar distribution of propeller noise.

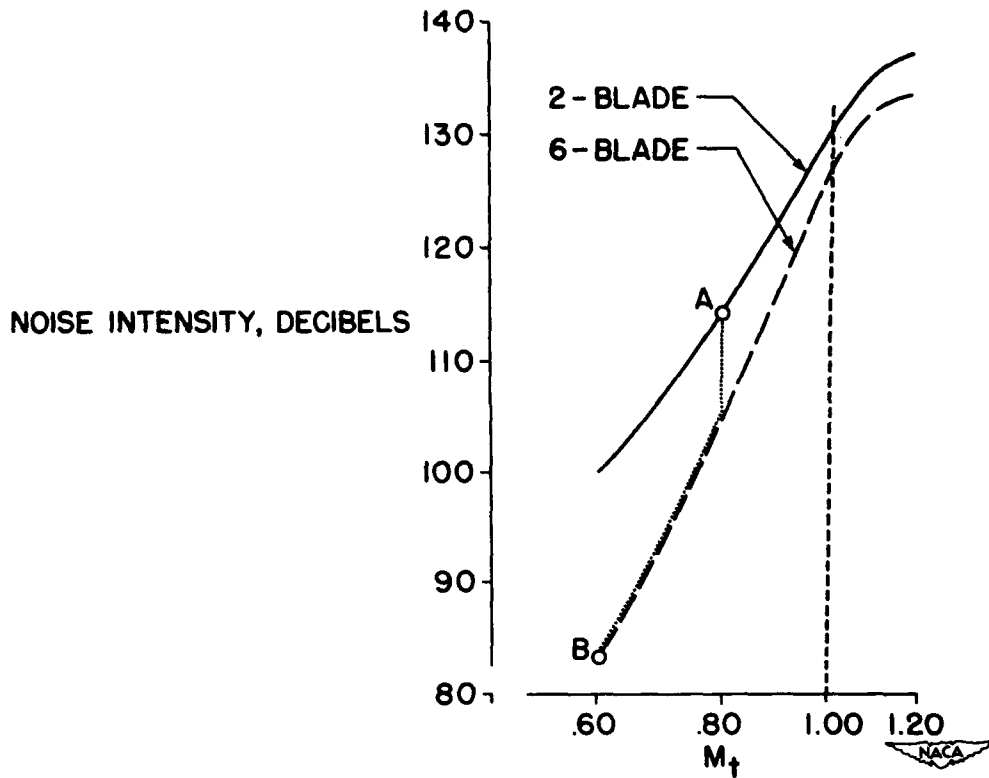

Figure 5. - Effects of tip Mach number and number of blades on the noise produced by single rotation propellers at constant power input.

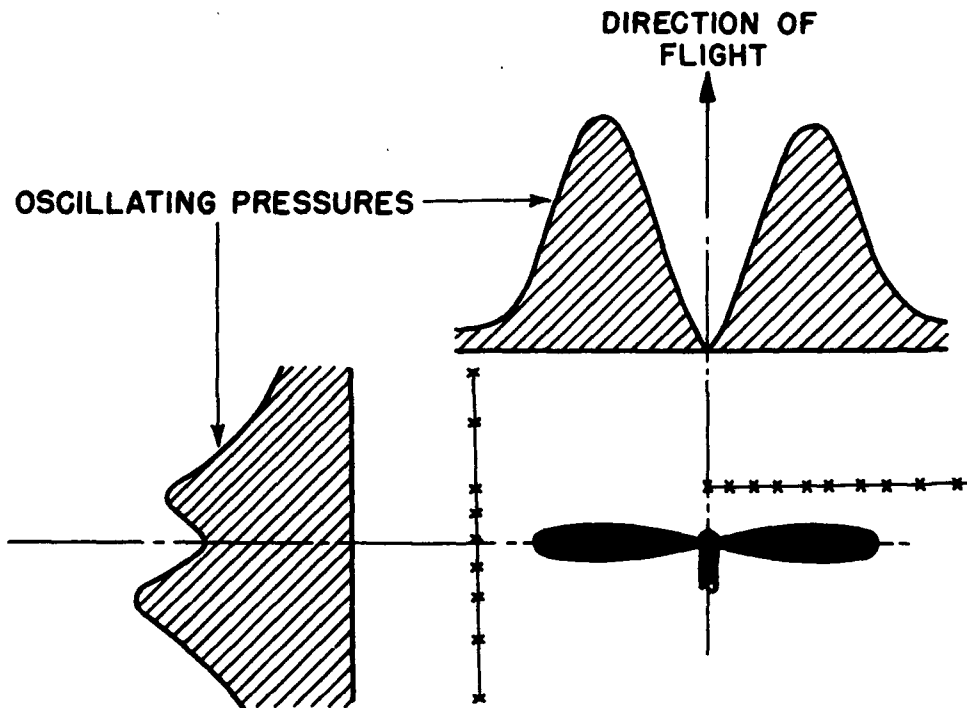
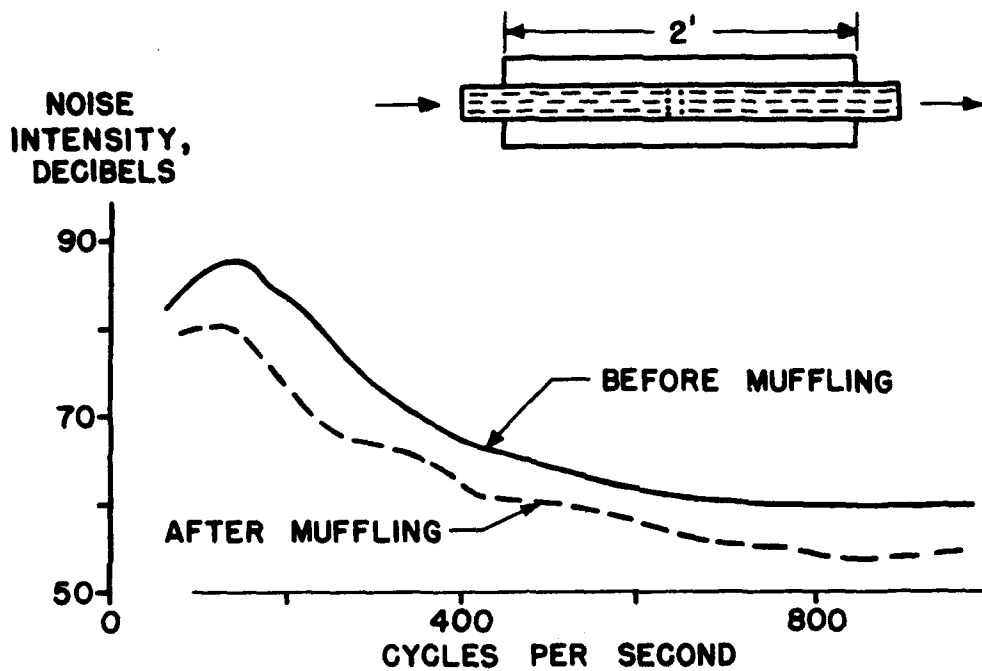

Figure 6. - Free space oscillating pressure distributions near a propeller.



NACA

Figure 7. - Exhaust noise spectra for a small reciprocating engine before and after muffling.

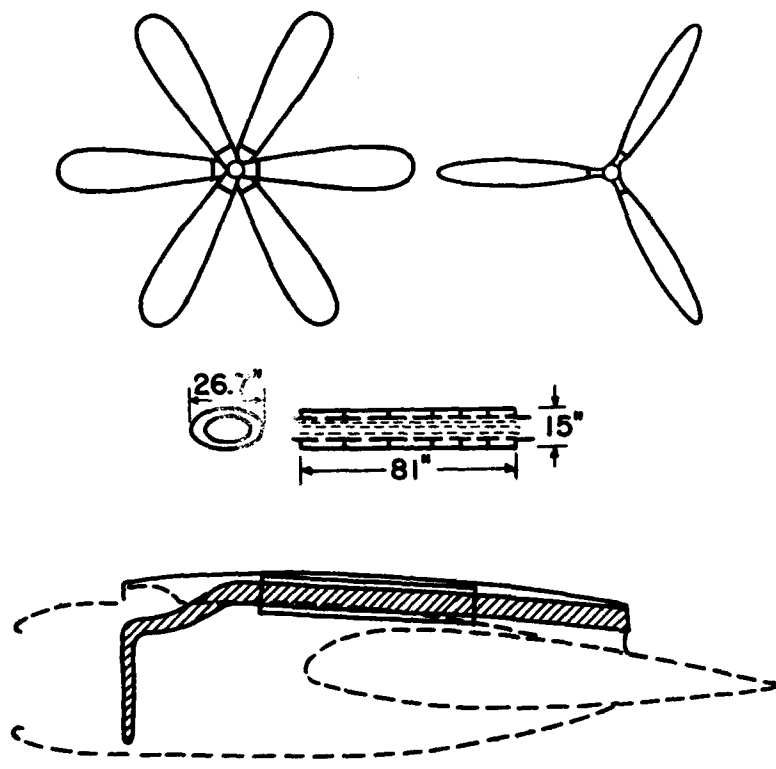

Figure 8. - Estimated modifications necessary for quieting the propeller and engine exhaust of a transport type aircraft.

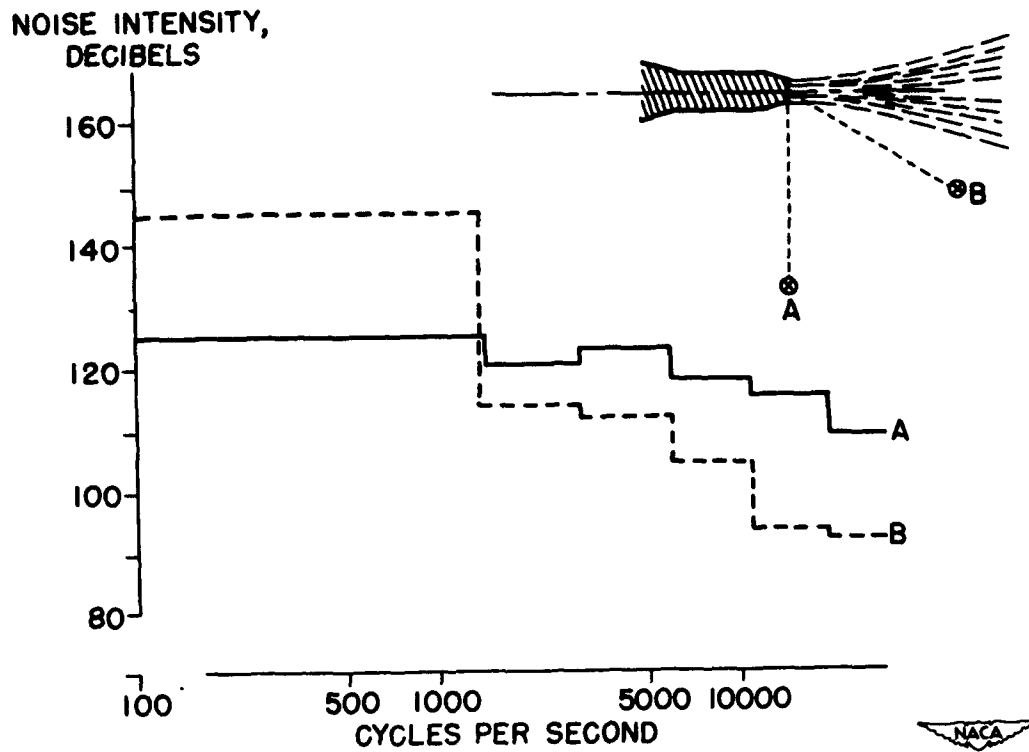

Figure 9. - Noise spectra for the TG-190 turbojet engine at take-off.

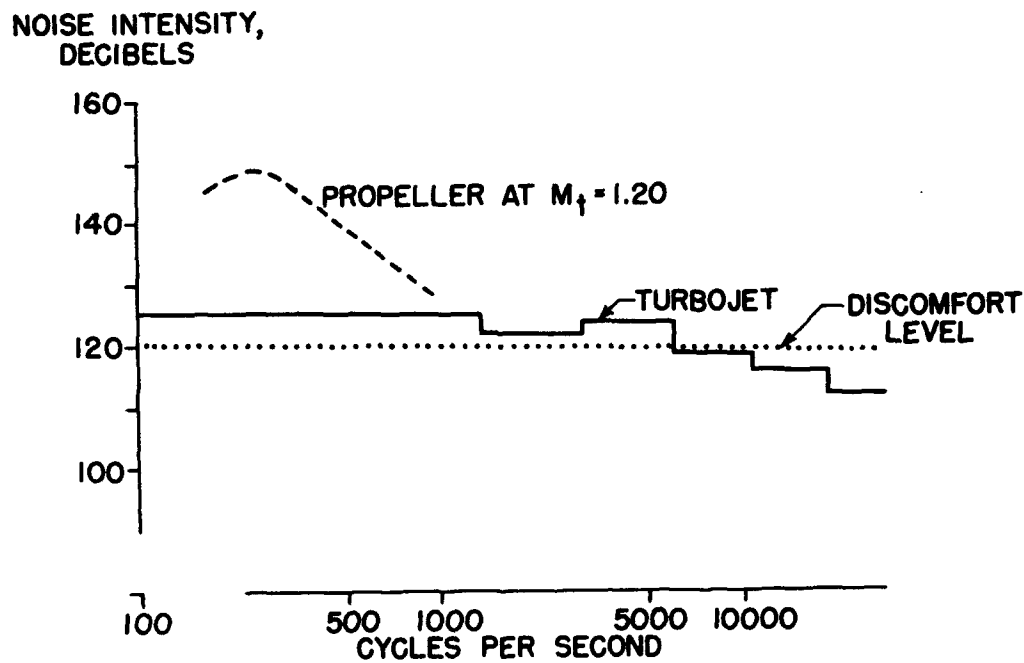

Figure 10. - Comparison of the noise produced by a turbojet engine and a $9\frac{1}{2}$ ft. diam. propeller operating at a tip Mach number of 1.20 for equal static thrust. (Distances are 12 feet from axis of jet and propeller tips respectively)

17. PROPELLER CONSIDERATIONS FOR HIGH-SPEED TRANSPORT AIRPLANES

By Blake W. Corson, Jr., and John L. Crigler

PROPULSION CONSIDERATIONS FOR HIGH-SPEED TRANSPORT AIRPLANES

17. PROPELLER CONSIDERATIONS FOR HIGH-SPEED TRANSPORT AIRPLANES

By Blake W. Corson, Jr. and John L. Crigler

Langley Aeronautical Laboratory

The problems associated with propellers designed for improved performance at high speed differ from those for low speed propellers not so much in character as in severity. Blade centrifugal stress, flutter, vibration, noise, abrasion, and icing are old problems. As increased power and speed require a greater degree of aerodynamic refinement, these problems in general become more difficult and change perhaps in relative importance, but otherwise are already familiar to the designer and operator. In looking ahead to some of the problems to be encountered in the design and operation of propellers for high-speed transport aircraft it is interesting to review some propeller developments of recent years.

Figure 1 illustrates recent progress in the development of high-speed propellers. The curves show the variation of efficiency with flight Mach number for propeller types intended for application in three different speed ranges. The sketch on the left indicates the kind of propeller which was in general use about a decade ago. The propeller is characterized by cylindrical blade shanks and by working blade sections about 10 percent thick. In a typical application a three-blade propeller of this type 10 feet in diameter would absorb 1700 horsepower at a rotational speed of 1700 rpm and flight speed of 350 mph. Such a propeller is intended for application at speeds up to Mach number of about 0.5, and for this speed range it is still the type of propeller most commonly used.

The break in the efficiency curve at Mach number 0.5 denotes the speed at which the adverse effects of compressibility cause an increase in drag of the cylindrical shanks and thick blade sections which leads to a rapid loss of efficiency with further increase in speed.

The second sketch indicates a more recently developed propeller type, now coming into general use, in which the major faults of the earlier type propeller have been eliminated. For this propeller the thickness ratio of the working sections has been reduced to about 7 percent, and the cylindrical shanks have been replaced by airfoil sections which extend to the spinner surface. The essential feature of this propeller is that it operates at relatively low values of rotational speed by which means the adverse effects of compressibility

are delayed until higher forward speeds are attained. These changes have resulted in a propeller which will operate efficiently at flight speeds up to Mach number 0.7, and in the lower speed range it is slightly more efficient than the older type propeller. In this case a practical application would be represented by use of a 14-foot diameter, 4-blade propeller turning at a rotational speed of only 800 rpm at a flight speed of 500 mph, and absorbing 3000 horsepower. In comparison with the earlier type propeller note that the larger diameter in this case is a result to some extent of the increased power, but arises for the most part from the decreased rotational speed. Reducing rotational speed is an effective method for delaying the adverse effects of compressibility but requires greatly increased propeller size.

The upper right hand sketch indicates a propeller type which is still in the development stage. It is essentially a highly refined version of the best modern propeller previously described and its characteristic feature is that its blade sections are extremely thin. For this type of propeller the designer accepts the fact that adverse compressibility effects can no longer be avoided by reduction of blade section speed, and therefore makes every effort to reduce the magnitude of the loss which he knows must occur. Reduced blade thickness has been found to be the most effective means for minimizing compressibility losses at high speed as illustrated by the consistent trend toward reduced thickness ratio shown on this chart. The shank sections of such a propeller are perhaps 7 percent thick, while the working portions of the blade may be no thicker than 2 or 3 percent. Also the relative width of the blades is greater than for the other two propeller types considered. For this very thin bladed propeller the speed at which the efficiency begins to decrease is appreciably greater than for the modern conventional propeller, but the interesting fact is that the efficiency does not decrease rapidly with increasing speed. At a flight Mach number of 0.9 the efficiency of this propeller remains greater than 75 percent.

A typical application for a propeller of this type is represented by the absorption of 5000 horsepower with a four-blade propeller 13 feet in diameter turning at 1400 rpm at a speed of 600 mph. Note that in comparison with the previous case although the power is increased more than 60 percent a decrease in diameter is made possible by the increased rotational speed. This trend at least indicates the possibility that for the high powered turbine engines soon to be available propeller sizes may not be greater than those now in use.

Included on this chart is a curve showing the variation of jet efficiency with flight Mach number. At the time when jets became popular the best available information on propeller efficiency similar

to the two curves on the left, indicated the definite superiority of the jet for speeds above 500 miles per hour especially when the lighter weight and simplicity of the jet were considered. For cases in which high speed was the deciding factor the jet was naturally chosen, but for long range aircraft capable of cruising at relatively low speed the propeller would give better performance. From information now available it appears that the thin high-speed propeller will compete with the jet at speeds up to 600 miles per hour, and for cruising at about 500 miles per hour offers 20 to 25 percent greater range.

The problems associated with propeller operation are common to all three propeller types described. The severity of the problems, however, increases with speed and degree of refinement. Many of the problems were solved for the older type propellers simply by the use of rugged construction. For the new propellers the refined aerodynamic design is not compatible with rugged construction and the designer's problem is becoming increasingly difficult. Because the high-speed propeller is still in the development stage, many of the operating problems are not completely defined. The remainder of this paper deals with some of the aerodynamic and structural trends associated with propellers suitable for application at speeds of 500 to 600 miles per hour to provide an indication of the sort of problems likely to occur in operation.

Figure 2 presents the variation of efficiency with flight Mach number for two propellers of the thin blade type having diameters of 10 and 16 feet respectively, but operating at greatly different values of rotational speed. Each of the propellers will absorb 5000 horsepower at a Mach number of 0.9.

If the important operating condition is high speed, for example, Mach number 0.9, or if most of the time will be spent in flight near maximum speed, the small diameter propeller turning at high rotational speed would be chosen because of its lighter weight and more simple gearing requirements. The difference in efficiency of the propellers at high speed is negligible. On the other hand, if Mach number 0.7 is the maximum design speed, or if high speed is only an occasional requirement and most operation will be with reduced power at lower speed, say 500 miles per hour, then a larger diameter propeller would offer better economy. For example, where cruising flight is maintained on half power or less by cutting out one unit of a double engine the larger propeller would operate with about 87 percent efficiency which is about 5 percent better than would be obtained with the smaller propeller. Except for having unusually thin blade sections this larger diameter propeller would in other respects be similar to the most refined propellers now in use.

While efficiency is one of the prime factors affecting propeller selection practical aspects of propeller application such as size, weight, and structural integrity are more often the decisive factors. Figure 3 presents the variation of diameter with power and rotational speed for propellers having design values of advance ratio of 2 and 4. Advance ratio, v/nD , is essentially the ratio of flight speed to propeller rotational tip speed and defines the aerodynamic geometry of propeller operation. For each curve the rotational tip speed is constant as shown by the second column. The points indicated on the solid curves cite the example chosen for the previous chart and show that as diameter is increased the rotational speed decreases rapidly. The column on the right shows typical values of maximum centrifugal stress for solid steel blades. These values show that the trend toward small size and high rotational speed is accompanied by a rapid increase in centrifugal stress which is a limiting factor in this direction. On the other hand, for very high powered installations mere size and weight of slow turning propellers makes the trend toward high rotational speed desirable.

A comparison of the two upper curves shows the effect of design speed on diameter. The curves present the variation of diameter with power for propellers of similar geometric design, the solid curve for a flight Mach number of 0.9, the dotted curve for Mach number of 0.75. The example illustrates a fortunate trend toward smaller diameters as flight speed is increased.

Another factor which critically affects propeller diameter is the variation of air density with altitude. For a given power, the propeller diameter required increases with altitude. However, because turbine engine power decreases with altitude the relation between propeller diameter, engine power, and altitude is a specific problem for each individual application.

While no criterion for the selection of propeller diameter is offered by this discussion, the material does illustrate that compromises must be made between size, weight, and structural integrity which from the practical viewpoint are more important than the small differences in efficiency. To absorb large amounts of power at moderate speed with best efficiency, the trend toward large diameter slow turning propellers is limited by physical size and weight. For the small diameter high-speed propellers the limiting factors are high blade stresses and poorer performance at moderate speed.

Of very great interest to the aircraft operator is take-off performance. Figure 4 presents the variation of thrust with air speed in the take-off speed range for the 10-foot and 16-foot diameter propellers

considered in the previous figures. For static conditions at sea level the power available for take-off was assumed to be 6900 horsepower.

In general it would be expected that a large diameter propeller would produce more thrust for take-off than a smaller propeller absorbing equal power. In this case, however, a larger propeller, which with no additional gearing would normally turn at 860 rpm, would be operating in a badly stalled condition and would produce a static thrust of only about 7000 pounds. The poor performance merely reflects the inability of the propeller to absorb the available power at low rotational speed without becoming stalled. This propeller under such operating conditions would also be very susceptible to stall flutter.

The improved performance attainable through use of a two-speed gear is shown by the dashed curve at the top. The same 16-foot diameter propeller is assumed, but for take-off its rotational speed is assumed to be increased to 1300 rpm by provision of a two-speed gear. For this condition the blade sections are no longer stalled, the static thrust is increased to 16,000 pounds, and the tendency towards stall flutter is greatly reduced.

The smaller high-speed propeller, 10 feet in diameter turning at 2760 rpm, produces close to 10,000 pounds static thrust. Because of its high disk loading and unavoidable compressibility loss the pounds-thrust per horsepower is much smaller than the commonly quoted figure of 2.5, but it does operate without being stalled. This fact together with the high rotational tip speed make for a propeller type for which the stall flutter problem at take-off is alleviated. Also because normal operation of this propeller requires extremely high rotational speed no additional gearing for speed change at take-off is required.

These limited observations indicate that aircraft designed principally for high-speed flight, Mach number 0.9 or greater, may well use relatively small high-speed propellers, and obtain satisfactory performance in take-off without the complication of a two-speed gear. For long-range aircraft required to cruise at moderately high speed, Mach number 0.7, consideration of efficiency demands a trend toward the use of relatively large propellers turning at low speed. For such aircraft take-off performance tends to become critical. In view of the very great increase in thrust for take-off made possible by the use of a two-speed gear, the practicability of such a feature is worthy of consideration.

To this point the discussion has been confined to a few of the aerodynamic aspects of propeller selection and operation. Of more

concern to the operator perhaps are the problems of flutter and vibration, because, these, if not solved, can lead to structural failure.

Figure 5 shows the variation of flutter speed coefficient with blade section angle of attack for two approximate values of tip Mach number. The flutter speed coefficient is the ratio of resultant speed to the product of blade width and blade torsional frequency, the resultant speed and blade width being measured at a typical section. Note that the denominator, the product of blade width and torsional frequency, is determined by physical characteristics of the propeller which to some extent can be controlled by the designer. For a given propeller this product is a constant and the ordinate scale therefore represents section speed, or for the static case, represents rotational speed. In the region below either curve the propeller will operate free from flutter.

For small values of section angle of attack, at which the blade cannot be stalled, flutter does not occur until a large value of the flutter speed coefficient is attained. In this angle range the flutter is of the classical type. At higher angles, however, between 8 and 24 degrees, the blade sections become stalled. Flutter is encountered at relatively low speed and is of the type designated as stall flutter. Because the flutter speed coefficient reaches its lowest values at section angles of attack, frequently encountered in take-off, the most serious flutter problem apparently will be stall flutter during take-off and climb.

Note that as the tip speed is increased the flutter boundary is raised, and there is good indication that at tip speeds somewhat greater than Mach number 1.0 flutter will not occur at all. In some cases a propeller which is safe for operation at a value of tip Mach number near 1.0, may be susceptible to stall flutter at low values of tip Mach number and therefore could not be brought to full rotational speed at a high value of section angle of attack required for take-off. In such a case it may still be possible to operate the propeller. The section angle can be reduced to 8 degrees, or less, where there is no danger of stall flutter, and the rotational speed increased to the normal rated value. For example, if this value of tip Mach number is approximately 1.0, the higher flutter speed boundary then applies, and stall flutter will not occur even at high angles of attack. It is then safe to increase blade angle to the value required for take-off and climb. When this critical phase of operation is completed there is little further danger from flutter because at higher flight speeds the blade section angles of attack are well below the stall range. For such a marginal propeller design, however, the same

procedure in reverse must be followed at the completion of a flight when the engine is shut off.

Another type of propeller vibration, illustrated in figure 6, is the so-called first-order vibration caused by operation with the thrust axis inclined to the air stream. First-order vibration is experienced by all propellers, but is most serious for those having large diameter and thin blades.

The figure to the left illustrates the nature of the exciting force which is the variation of thrust exerted by the blade as it turns through one revolution. When the thrust axis is inclined to the air stream a blade on one side of the propeller disk operated at increased angle of attack and experiences an increased thrust; on the other side of the disk the angle of attack of the blade is decreased and the blade suffers a loss of thrust. For each blade the changing load cycle is completed during each revolution and the frequency of this excitation is equal to the propeller rotational speed.

The angle of thrust axis inclination, α_T , illustrated by the upper right hand sketch, is determined by all factors which can produce a skewed air flow, sideslip as well as angle of attack, also upwash ahead of the wing or unsymmetrical flow created by the engine nacelle and fuselage. There have been cases in which taxiing in a cross wind gave rise to first-order vibration. If the effective angle of inclination is known the vibratory stress can be calculated.

The blade stresses produced by the oscillating load increase directly as the product of the angle, α_T , and dynamic pressure as shown in the lower part of the figure. The product, $\alpha_T q$, has an appreciable value over most of the operating range of the aircraft. At low speed dynamic pressure is small but α_T is large, at high speed the reverse is true. Excitation can occur under all operating conditions, though it may be alleviated at high speed or cruise if the designer can achieve a small value of α_T for these conditions.

The only encouraging aspects of this problem are that the cause of the vibration is known, and that the blade vibratory stress can be calculated if the flow field in the propeller disk is known either from calculation or from wind tunnel tests of a model. In the lower figure the solid line presents calculated values of stress for a propeller used in a wind tunnel investigation; the points on the curve are measured values.

The problem is sufficiently serious to make necessary special operating techniques for some propellers now being used, and the future application of very thin propellers does not promise to ease the problem. Operation near resonant speed should be avoided. Also, in the case where a long period in climb is required, or for level flight with a heavily loaded aircraft, operation with partially deflected flaps will help to reduce the angle of attack and thereby minimize propeller vibration.

The noise created by the small diameter high-speed propellers operating at supersonic tip speeds will certainly be objectionable. Conceivably, the sound pressures could be sufficiently great to cause structural damage to an aircraft. If this should be the case, noise would become a limitation to the use of small high-speed propellers. The noise problem is not at all critical for the large slow turning propellers.

Because of the improved efficiency at high speed attainable by the use of very thin blades, serious effort will be directed toward the development of thin-blade propellers.

For the speed range near Mach number 0.9 the trend will probably be toward the use of relatively small diameter propellers turning at high rotational speed. At this speed such a propeller will operate with efficiency better than 75 percent. The small size results in a lighter weight propeller, and high rotational speeds make possible the use of smaller and lighter reduction gears without the necessity for additional gearing to improve take-off. For the small high-speed propeller the flutter and vibration problem will probably be less critical than for large, slowly turning propellers.

Where cruising at reduced power and speed is important, the favorable trend is toward the use of large diameter, slow turning propellers because these operate with better efficiency than other types in the moderate speed range. For these propellers, however, flutter and vibration will be critical problems. Also to obtain best take-off performance may require the development of two-speed gears. In cases where flutter and vibration are critical, these problems may be avoidable by the use of special operating techniques.

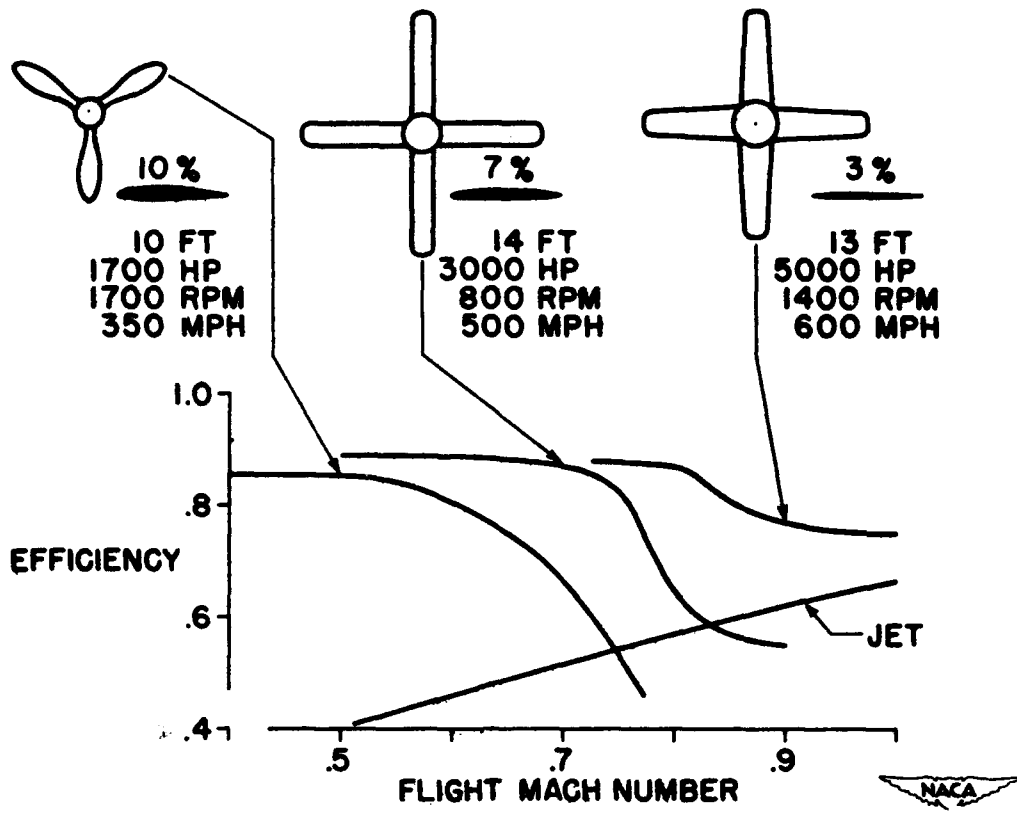

Figure 1. - Variation of efficiency with flight Mach number for three different propeller types.

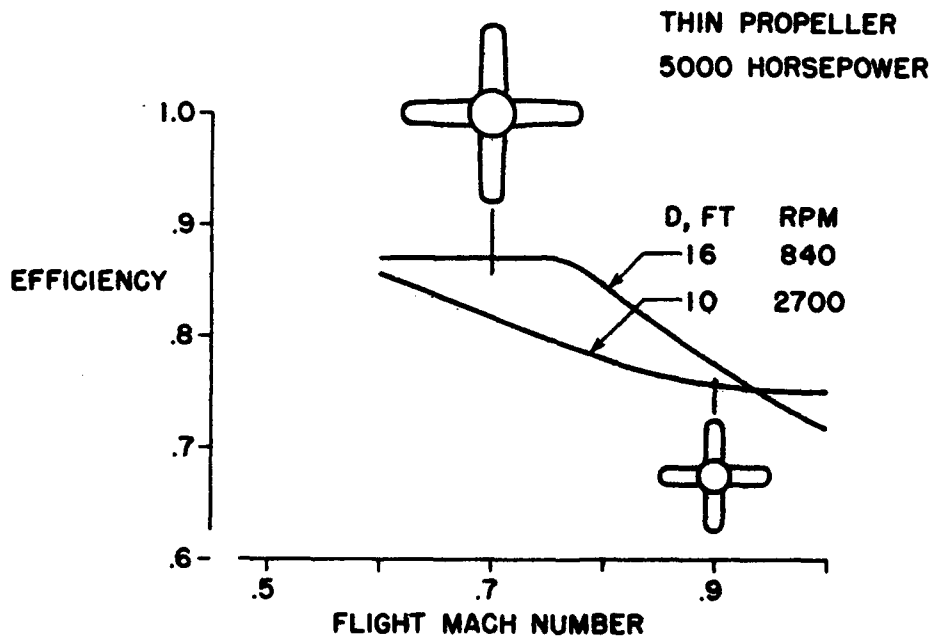

Figure 2. - Variation of efficiency with flight Mach number as affected by diameter and rotational speed.

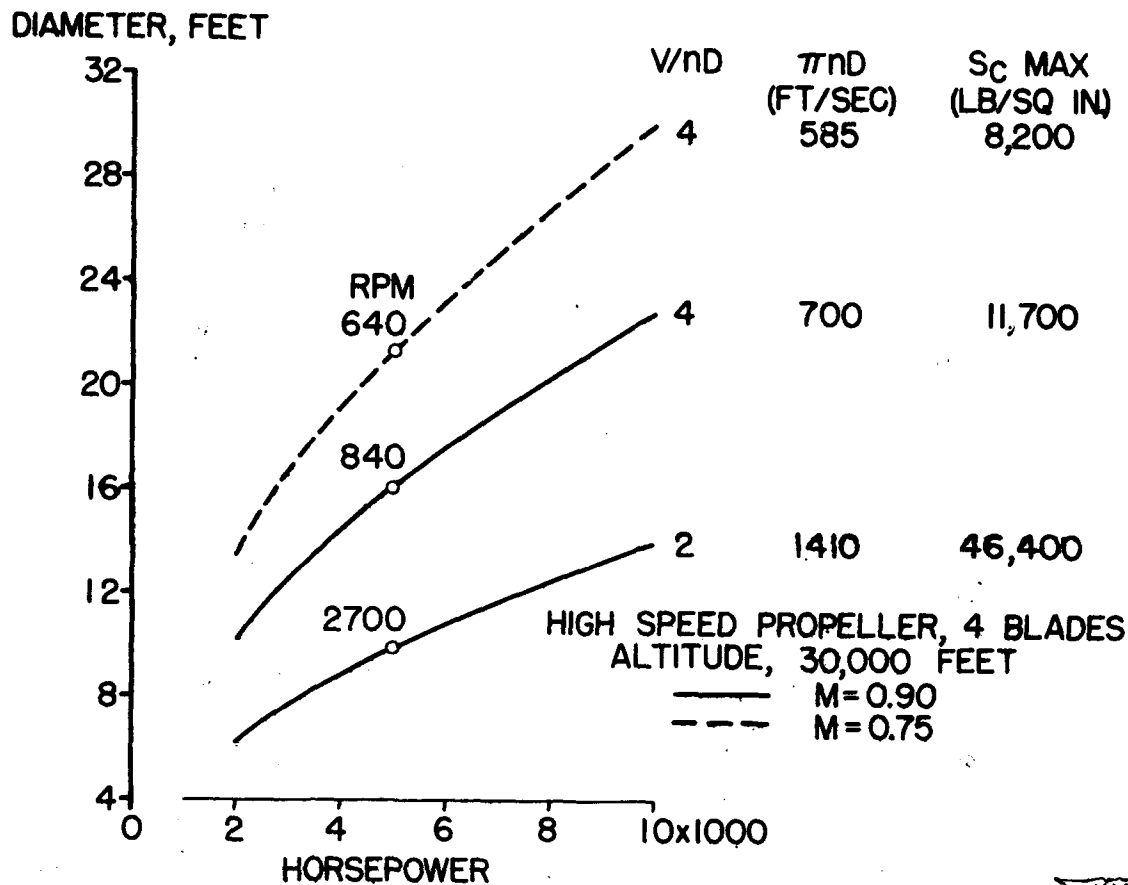

Figure 3. - Variation of diameter with power and rotational tip speed.

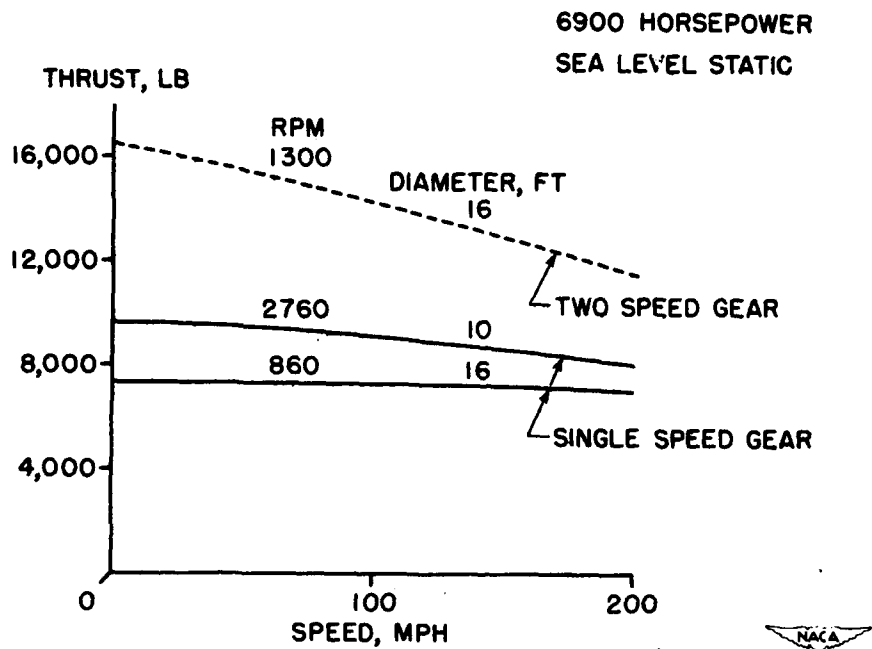

Figure 4. - Variation of thrust with airspeed in take-off.

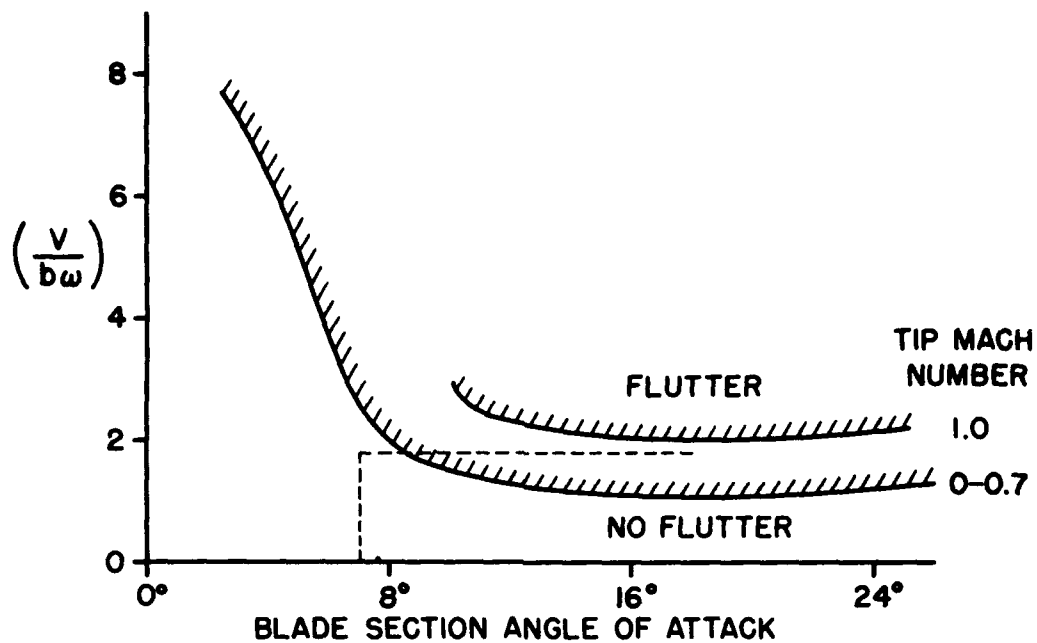

Figure 5. - Variation of flutter speed coefficient with blade section angle of attack.

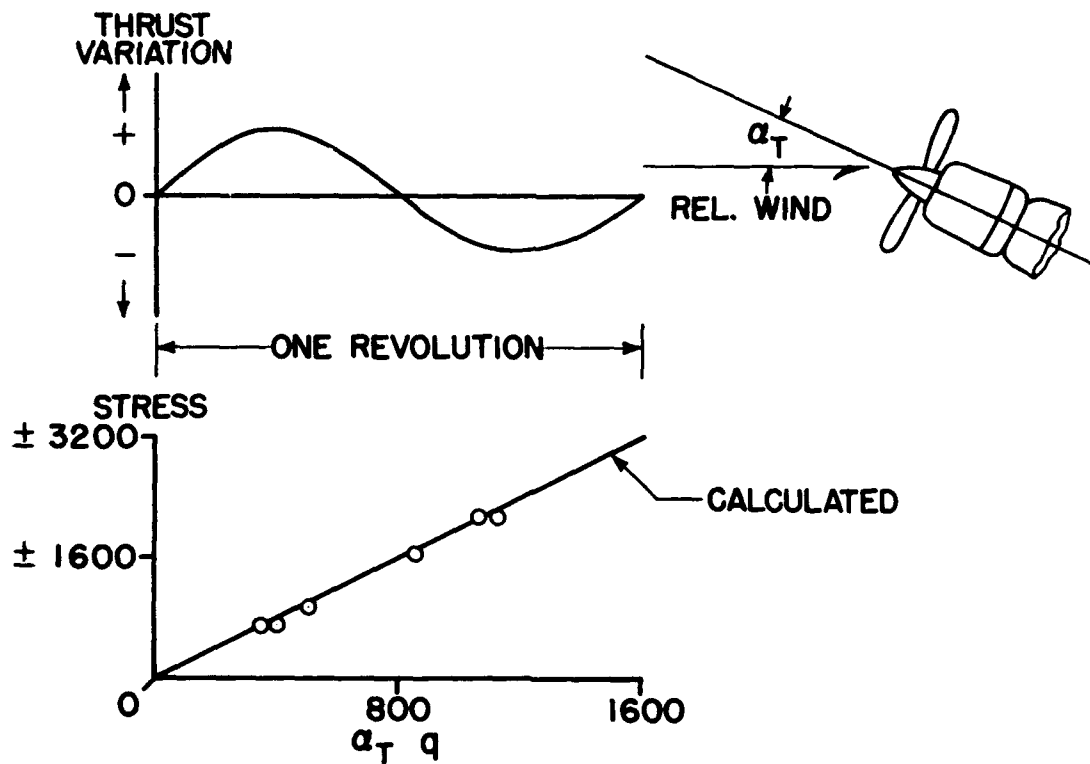

Figure 6. - First order vibration - excitation and blade stress.

18. POWER PLANTS FOR HIGH-SPEED TRANSPORT AIRPLANES

By Bruce T. Lundin and Eldon W. Hall

PROPULSION CONSIDERATIONS FOR HIGH-SPEED
TRANSPORT AIRPLANES

18. POWER PLANTS FOR HIGH-SPEED TRANSPORT AIRPLANES

By Bruce T. Lundin and Eldon W. Hall

Lewis Flight Propulsion Laboratory

The introduction and subsequent development of the gas-turbine power plant within the recent postwar period offers possibilities of greatly improved transport aircraft performance and, at the same time, introduce many new and complex problems of both engine and aircraft operation. Both the performance and operational characteristics of the gas-turbine engine differ greatly from those of the familiar reciprocating engine, and these differences will have a marked effect on transport aircraft performance and operational procedures. Although the application of the turbine-propeller and turbojet engines to transport aircraft has been actively studied and discussed from a performance point of view by many investigators in recent months, rapid progress of engine development necessitates constant reevaluation, and many difficulties of engine operation remain to be adequately defined and solved.

The main performance characteristics of the turbine-propeller engine that are of interest to aircraft operation are illustrated in figure 1, where the thrust per unit engine weight and the thrust specific fuel consumption are plotted against flight speed. These curves are for an altitude of 35,000 feet, although the general trends are the same for any altitude. The principal characteristics illustrated by these curves are the decrease in thrust and the increase in specific fuel consumption as flight speed is increased. At a speed of 600 miles per hour, for example, the thrust is just about one-half as great and the specific fuel consumption is nearly three times as high as at a speed of 300 miles per hour. This decrease in engine performance with increasing flight speed is a direct result of the frequently mentioned constant-horsepower characteristics of the turbine-propeller engine. In other words, if the engine performance is expressed in terms of horsepower instead of on a thrust basis, the brake horsepower per unit engine weight and the brake specific fuel consumption would be approximately constant over the range of flight speeds presented and numerically equal to the values indicated at a speed of 375 miles per hour.

The main performance characteristics of the turbojet engine are presented in figure 2 where the thrust per unit engine weight and the thrust specific fuel consumption are plotted against the flight speed. The solid curves refer to the turbojet engine and the dashed curves show, for comparison, the characteristics of the turbine-propeller engine that were illustrated in figure 1. In contrast to the constant-power characteristics of the turbine-propeller engine, the turbojet engine is essentially a constant-thrust device, with both the thrust and the specific fuel consumption remaining substantially unaffected by flight speed. A comparison of the performance characteristics of the turbine-propeller and the turbojet engine reveals that, at low flight speeds, the thrust of the two engines is about the same but that the fuel consumption of the turbojet engine is about three times that of the turbine-propeller engine. As the flight speed is increased, however, the thrust of the turbojet engine becomes much greater than that of the turbine-propeller engine, and the difference in specific fuel consumption of the two engines becomes small.

Although the engine performance characteristics illustrated in figures 1 and 2 afford some appreciation of the potentialities of these gas-turbine power plants, an adequate evaluation of their utility for transport aircraft must consider the aerodynamic and structural characteristics of the airplanes in which they are used. One such analysis is a study of the range or distance each type of power plant may carry a given pay load at various flight speeds and altitudes. An illustration of the results of such a range study is shown in figure 3, where the flight range is plotted against the flight speed with the two curves indicating the capabilities of the turbine-propeller and of the turbojet engine. The power plant providing the greater range at a given flight speed is obviously the superior engine even if that value of range is longer than desired because shorter ranges could be covered with that engine with either a smaller fuel expenditure or a larger pay load. These results are based on design point studies, that is, both the airplane and engine are varied to obtain optimum performance at each point, in order to illustrate the potentialities of these two types of engine and to evaluate their relative ranges of application. Some of the main airplane assumptions that were used are a pay load of 10 percent of the gross weight, a structure weight of 40 percent of the gross weight, a Breguet flight plan, and a maximum wing loading of 60 pounds per square foot. As would be expected from the performance characteristics of the turbine-propeller engine, the range provided by this engine decreases

rapidly as flight speed is increased. The range provided by the turbojet engine, however, increases with increasing flight speed until the high drag region of compressibility is reached. The turbine-propeller engine is superior to the turbojet engine for flight speeds up to about 520 miles per hour and, at higher flight speeds, the turbojet is the better engine. From the standpoint of range and pay-load capabilities, the most effective application of these engines is in the region of 400 to 500 miles per hour for the turbine-propeller engine and in the region from 500 to 600 miles per hour for the turbojet engine.

As indicated in figure 3, these results are for an altitude of 35,000 feet for both engines. Analysis for other flight altitudes resulted in somewhat different values of range, but the cross-over point between the turbine-propeller and the turbojet engine remained essentially the same for all altitudes. This study of various altitudes of operation also indicated that the optimum altitude for both types of power plant was between 30,000 to 40,000 feet. The flight range at an altitude of 20,000 feet was of the order of 80 percent of that shown in figure 3 for an altitude of 35,000 feet.

In order to illustrate the characteristics of a given airplane over a range of flight conditions, the performance of a selected airplane and power plant was analyzed and is summarized in figures 4 and 5. The design flight condition was chosen as 450 miles per hour at an altitude of 30,000 feet for the turbine-propeller engine and as 600 miles per hour at an altitude of 35,000 feet for the turbojet engine. For both types of power plant, a gross airplane weight of 150,000 pounds was assumed and a pay load of 15,000 pounds, or 10 percent of the gross weight, is carried. The airplane structure was taken as 40 percent of this gross weight, and the fuel tank weight as 10 percent of the total fuel weight. The analysis included the fuel required to climb to cruise altitude, and a reserve fuel of 10 percent of the total fuel was allowed. This value of reserve fuel was chosen instead of the more conservative current CAA requirements in the belief that present stacking procedures for landing or resort to alternate landing fields in event of poor weather cannot be tolerated if the full potentialities of these gas-turbine power plants are to be realized. The wing loading was assumed as 60 pounds per square foot for both airplanes. This rather moderate value of wing loading was used in consideration of the landing problem and to assure sufficient volume in the wing to carry the fuel. Both airplanes are considered to be powered by four power plants.

The performance of the turbine-propeller-powered airplane is presented in figure 4 as a plot of range against flight speed for various altitudes. The design point is indicated by the circle at a speed of 450 miles per hour and an altitude of 30,000 feet. At this design condition, a flight range of slightly over 5000 miles is obtained. The power plant was taken to be of sufficient size to fly the airplane at this design condition at normal continuous rating. With this size of power plant, the airplane is capable of flying at altitudes 5000 feet over the design altitude, but the maximum continuous flight speed is limited to about 450 miles per hour. The range remains essentially independent of flight speed over a range from 300 to 450 miles per hour, but falls off as the flight speed is reduced below 300 miles per hour. This reduction in range at low flight speeds is due to the combined effects of the reduction in airplane lift-drag ratio at off-design-point flight and the increase in specific fuel consumption of the engines at part throttle. At a speed of 300 miles per hour at an altitude of 20,000 feet, it is possible to fly the airplane on two engines, and the lower specific fuel consumption of the two engines at full power compared to four engines at 50 percent power results in the discontinuity in the range curve at this point. If it is necessary to depart from the design altitude because of unfavorable weather or head winds, an increase in altitude will permit attainment of the design range at a slight sacrifice in flight speed. If, however, it should become necessary to reduce altitude, either the range must be decreased (fig. 4) or the payload must be reduced. A comparison of the various altitude curves indicates that a reduction in altitude from 30,000 to 20,000 feet will result in a reduction in range of 25 percent. The dot-dash curve indicates the airplane-flight limitations on three engines, that is, the performance that would be obtained if an engine failure occurred near the start of the flight. In this event, the flight speed would be reduced about 50 miles per hour below the design value, but attainment of the design range is still possible.

A similar set of performance curves for the turbojet-powered transport is presented in figure 5 where the range is plotted against flight speed with the various curves referring to different flight altitudes, and the circle indicating the airplane and engine design point. At the design speed of 600 miles per hour, a range of slightly over 2200 miles is obtained. In this case, the engines chosen were slightly larger than necessary for cruise operation at the design point in order to permit flight at slightly higher altitudes and to partly relieve the take-off problem, which will

be subsequently discussed in detail. The range provided by the turbojet-powered airplane is somewhat more sensitive to flight speed than that of the turbine-propeller airplane; the range decreases from the design value as the flight speed is either increased or decreased. The effect of a change in altitude on the range is about the same as that of the turbine-propeller airplane with a decrease in altitude of 10,000 feet below the design value necessitating a decrease in range of about 25 percent. In event of an engine failure, not only is a reduction in flight speed required but, unlike the turbine-propeller powered airplane, a reduction in both altitude and range below the design values will be necessary.

The engine-performance characteristics used in the preceding analyses were the same as those illustrated in figures 1 and 2 and were chosen to be representative of the performance of engines that are either available or in final development at the present time. As such, these analyses are in substantial agreement with the results of many other investigations that have been actively discussed within recent months. It is therefore of interest to investigate how this picture will be changed if the improvements in engine performance that are indicated by research and development now in progress are realized. These improved engines shall be designated as future engines and are viewed as the type of power plant that may be available to the transport industry in the near future.

The characteristics of the turbine-propeller engine are shown in figure 6; the values without the box around them refer to present engines and the values within the box are for future engines. All the values shown refer to engine operation at continuous or normal cruising conditions. Both the compressor pressure ratio and turbine-inlet temperature would be somewhat higher at maximum rated engine conditions. The compressor pressure ratio P_3/P_2 was increased from 6 for the present engine to 8 for the future engine, and a turbine-inlet temperature T_4 of 1900° R was taken for both engines. The use of turbine cooling to permit higher turbine-inlet temperatures for the future engine is not considered because analysis indicates it to be of only minor benefit for the range of engine and flight conditions presented herein. The component efficiencies were each increased 3 percent for the future engine, giving a compressor efficiency η_c of 88 percent, a combustion efficiency η_b of 98 percent, and a turbine efficiency η_t of 91 percent for the future engine. The variation in propeller efficiency with flight speed is

illustrated in the small plot in figure 6. For the present engine, the efficiency was assumed constant at 85 percent up to a flight Mach number of about 0.6, after which the efficiency dropped to 50 percent at a Mach number of 0.9. For the future engine, the efficiency was increased to 90 percent in the low speed range and was assumed to drop to 75 percent at a Mach number of 0.9. The engine air flow W_a/A_c at sea-level conditions was taken as 15 pounds per second per square foot of compressor frontal area for the present engine, which was increased to 20 for the future engine. Only moderate increases in component efficiency and pressure ratio were considered for the future engine with principal emphasis being placed on engine air flow and propeller efficiency because analysis has shown these factors to be of greatest importance. All these assumptions are considered to be fairly realistic and possible of attainment without extensive development.

The characteristics chosen for the present and future turbojet engines are illustrated in figure 7. The compressor pressure ratio of this engine was somewhat lower than for the turbine-propeller engine, being 4.5 for the present engine and 6.0 for the future engine. For both engines, the turbine-inlet temperature was maintained at 1900° R and an exhaust-nozzle efficiency of 95 percent was used. The component efficiencies are the same as those previously indicated for the turbine-propeller engine. The air flow was taken as 25 pounds per second per square foot of compressor frontal area for the present engine and 30 pounds per second for the future engine. All these assumptions, in particular the engine air flow and pressure ratio, may be considered rather conservative when compared to the anticipated performance of some engines now under development for the military services, but were so taken in the belief that they would thus be most representative of engines that would be available to the transport industry in quantity production at moderate cost.

The improvement in airplane performance afforded by the future engines is illustrated by a design-point-range study in figure 8. In this figure, the two solid lines refer to the future turbine-propeller and turbojet engines and, for comparison, the dashed lines indicate the performance of present engines. This comparison between present and future engines shows that the range performance of both the turbine-propeller and the turbojet airplane is greatly improved by the future engine. At the design-point speed of 450 miles per hour for the turbine-propeller engine, which is indicated by the vertical line, the range is increased from about 5000 miles with present engines up to 8500 miles with the future engines, or an increase of 70 percent.

As previously mentioned, these range capabilities may be considered as a relative rating, or figure of merit of the power plant, even if ranges as large as 8500 miles are unnecessary. For example, it was computed that, for a range of 5000 miles for both engines, the pay load that could be carried could be increased from 15,000 pounds with the present engines up to over 38,000 pounds with the future engines, or an increase of over two and a half times. This increase in airplane performance with the future turbine-propeller engine is largely the result of higher component efficiencies and air-flow capacity at low flight speeds and nearly half the gain at high flight speeds is due to the higher propeller efficiency. For the turbojet-powered airplane, the range at a design speed of 600 miles per hour, shown by the vertical line in figure 8, is increased from 2200 miles with present engines up to 3100 miles with the future engines, or an increase of about 40 percent.

Although large improvements in performance are thus predicted for both turbine-propeller- and turbojet-powered aircraft, the magnitude of these future gains is somewhat greater for the turbine-propeller engine than for the turbojet engine. As a result, the cross-over point between the turbine-propeller and the turbojet engine is extended from about 520 miles per hour for present engines to over 600 miles per hour for the future engines. Although the exact value of this cross-over point is admittedly sensitive to the assumptions used, the fact remains that the anticipated future development of both the turbine-propeller and turbojet engines will be of greater benefit to the turbine-propeller engine.

As previously mentioned, the size of the power plants used in the preceding performance analysis was chosen to be just sufficient to fly the airplane at the design flight condition with, in the case of the turbojet engine, a small increase to permit flight at a higher altitude. It therefore becomes necessary to investigate the take-off situation with both turbine-propeller and turbojet engines. This take-off problem is the same for both the present and future engines because the airplane gross weight and the total thrust output of the engines are identical.

One factor that aggravates the take-off problem is the decrease in thrust of these engines at high ambient air temperatures. The magnitude of this effect is shown in figure 9, where the ratio of take-off thrust to rated engine thrust is plotted against the air temperature. Curves are shown for both turbojet and turbine-propeller engines, with the effect of air temperature being most

pronounced for the turbine-propeller engine. At an air temperature of 100° F, the take-off thrust of the turbine-propeller engine is reduced to about 75 percent of the rated value and the turbojet engine has lost about 10 percent of its rated thrust.

In spite of the large reduction in take-off thrust of the turbine-propeller engine with increasing ambient temperature, the inherent large horsepower of this type of engine affords satisfactory take-off performance even at high air temperatures. For the turbine-propeller airplane, which was equipped with sufficient power to fly at 450 miles per hour at 30,000 feet under cruise engine conditions, the take-off distance with an air temperature of 100° F is only about 3500 feet.

For the turbojet airplane, however, which was provided with engines that were slightly larger than necessary to cruise at 600 miles per hour and 35,000 feet, the take-off distance was computed to be about 9000 feet. In order to reduce this take-off distance to practical values, the engine thrust at take-off must obviously be increased. Increasing the number or size of the engines to obtain this increase in thrust would penalize the cruise performance of the airplane. The magnitude of this loss in airplane performance when the engines are increased in size is shown in figure 10 where flight range is plotted against take-off distance. The take-off distances (fig. 10) were computed for design aircraft gross weight and an ambient temperature of 100° F and are sufficient to clear a 50-foot obstacle. Current CAA requirements were used which permit all four engines to be used at full rated power for the initial ground run but, after a critical point is reached, require the take-off to be completed with one engine dead. As previously mentioned, the attainment of the design range of 3100 miles, which is indicated by the dashed line, requires a take-off distance of 9000 feet. As the take-off distance is decreased by increasing the size of the engines, the range is decreased because of the greater weight and size of these engines and because of the higher specific fuel consumption associated with part-throttle operation. With sufficient engines to provide a take-off distance of 3000 feet, the range is reduced to 2200 miles, or about 30 percent below the design value.

The loss in range illustrated in figure 10 need not be tolerated if the normal engine installation is retained and if the additional thrust required for take-off is obtained by some other means. This extra thrust for take-off can be obtained by rocket-assist units; but this method is rather expensive and has other

obvious disadvantages for widespread commercial use. The use of special methods for augmenting the thrust of the turbojet engine for short periods of time therefore becomes of particular interest.

Experimental and analytical investigations of various methods of thrust augmentation have been in progress at the Lewis laboratory for several years, and a summary of the results of several of the investigations is presented in figure 11. In this figure, the ratio of augmented to normal thrust is plotted against the ratio of liquid or fuel flow with augmentation to the normal engine fuel flow. Three different methods of thrust augmentation are illustrated, each of which is advantageous for various ranges of application. The use of tail-pipe burning, or the burning of additional fuel in the engine tail pipe to raise the exhaust-gas temperature higher than permitted by the turbine-blade materials, is obviously the best method from the standpoint of low liquid consumption and provides a thrust ratio of up to nearly 1.5 for a liquid consumption ratio of about 3.5. This point is very close to maximum possibilities, which are reached when enough fuel is injected into the engine tail pipe to completely burn all the air that passes through the engine. The water-injection method is limited to thrust ratios of the order of 1.25 and requires considerably higher liquid flow rates than the tail-pipe-burning method. Because of the extreme simplicity and small additional weight of this method, however, it is probably the most desirable if only moderate thrust increases are required for short periods of time.

Because the use of water injection increases the compressor pressure ratio and because the use of tail-pipe burning increases the exhaust-gas temperature, these two methods work well together and actually augment each other. Thus, these two methods may be used in combination when very large thrust increases are required. Some of the results obtained by this combination method are also indicated in figure 11 for two different rates of water injection. This type of augmentation may be used to cover the range of thrust-augmentation rating from about 1.5, or the maximum possibilities of tail-pipe burning, up to nearly 1.7. Thus, these effective methods of increasing the thrust of the turbojet engine may be used to help solve the take-off problem.

The reduction in take-off distance permitted by these methods of thrust augmentation is illustrated in figure 12 where the take-off distance is plotted against the ratio of augmented to normal engine thrust. Adjacent to the abscissa scale is shown the range

of applicability of each of the three methods of thrust augmentation. The take off distance decreases rapidly as the amount of thrust augmentation is increased; the use of water injection alone provides a reduction from 9000 feet to 5600 feet. For a take-off distance of 4000 feet, a take-off thrust ratio of 1.45, which is near the upper limits of tail-pipe burning, is required. The extra fuel required to operate the tail-pipe burner for this amount of augmentation during the take-off period was computed at about 2.5 percent of the total fuel load, of which the largest part is consumed during the ground run. The use of the combination of water injection and tail-pipe burning, which provides a thrust ratio of nearly 1.7, would permit a further reduction in take-off distance to 3000 feet.

This brief survey of some of the performance characteristics of gas-turbine power plants has indicated that the constant-power characteristics of the turbine-propeller engine result in its most effective application at flight speeds between 400 and 500 miles per hour and that the constant-thrust characteristics of the turbojet engine make this engine most effective at speeds from 500 to 600 miles per hour. Very large increases in the capabilities of both of these power plants are indicated by anticipated future development, particularly for the turbine-propeller engine. Desirable cruising altitudes are of the order of 30,000 to 40,000 feet for both engines, with both engines being about equally affected by departure from the design altitude. The turbine-propeller engine was found to have sufficient power to take off on a hot day with engines properly sized for cruising conditions, but the take-off characteristics of the turbojet engine were such that special thrust augmentation methods will be necessary for take-off use if the full potentialities of this engine are to be obtained. Adequate thrust augmentation methods are available, however, with the tail-pipe-burning method providing a take-off distance of 4000 feet with an engine installation designed for most efficient use at cruising conditions.

2025

TURBINE-PROPELLER ENGINE PERFORMANCE CHARACTERISTICS

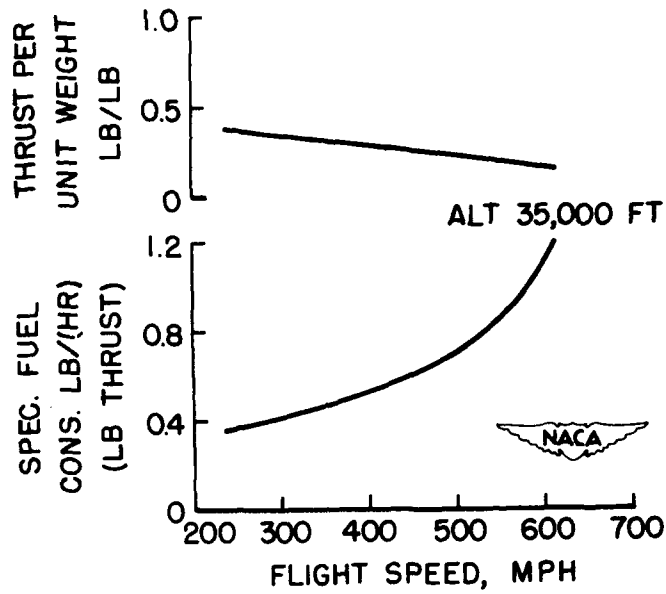

Figure 1

TURBOJET ENGINE PERFORMANCE CHARACTERISTICS

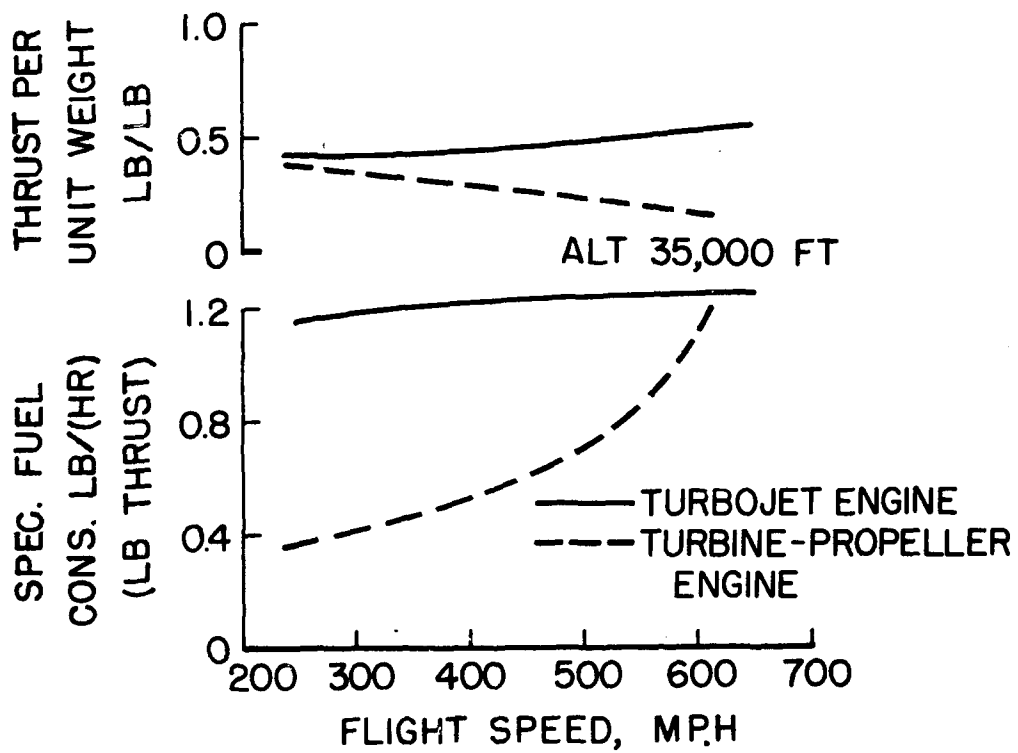

Figure 2

COMPARATIVE RANGE PERFORMANCE OF TURBINE PROPELLER AND TURBOJET ENGINES

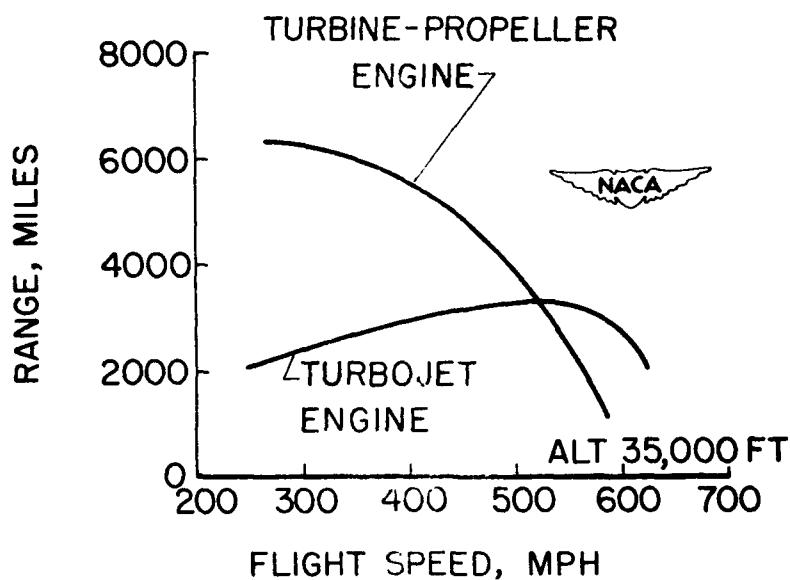

Figure 3

RANGE PERFORMANCE OF TURBINE-PROPELLER TRANSPORT

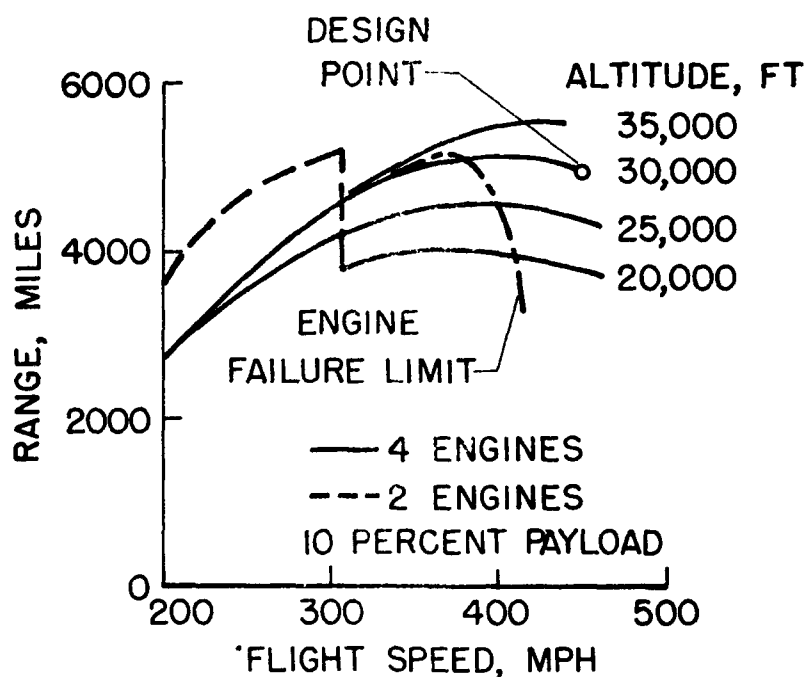

Figure 4

RANGE PERFORMANCE OF TURBOJET TRANSPORT

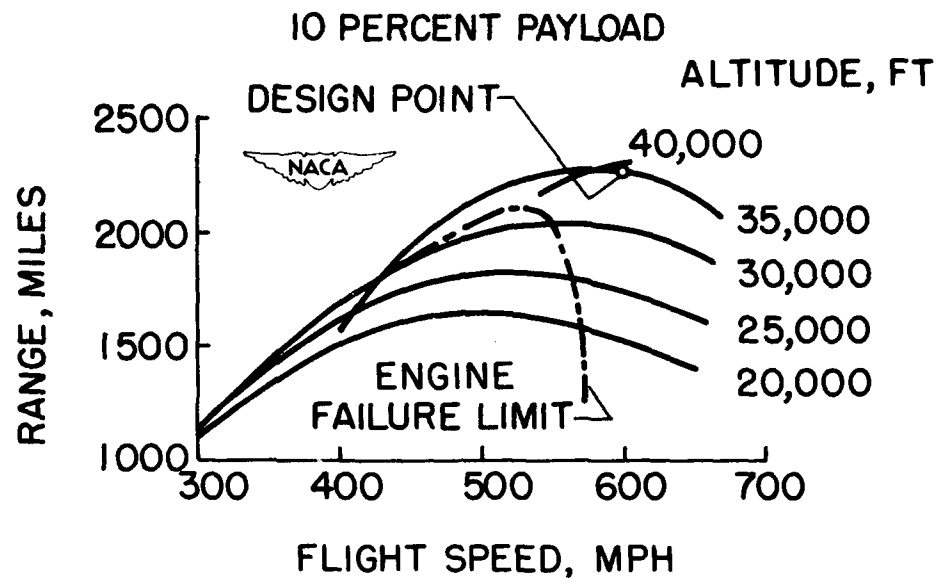

Figure 5

TURBINE-PROPELLER ENGINE ASSUMPTIONS

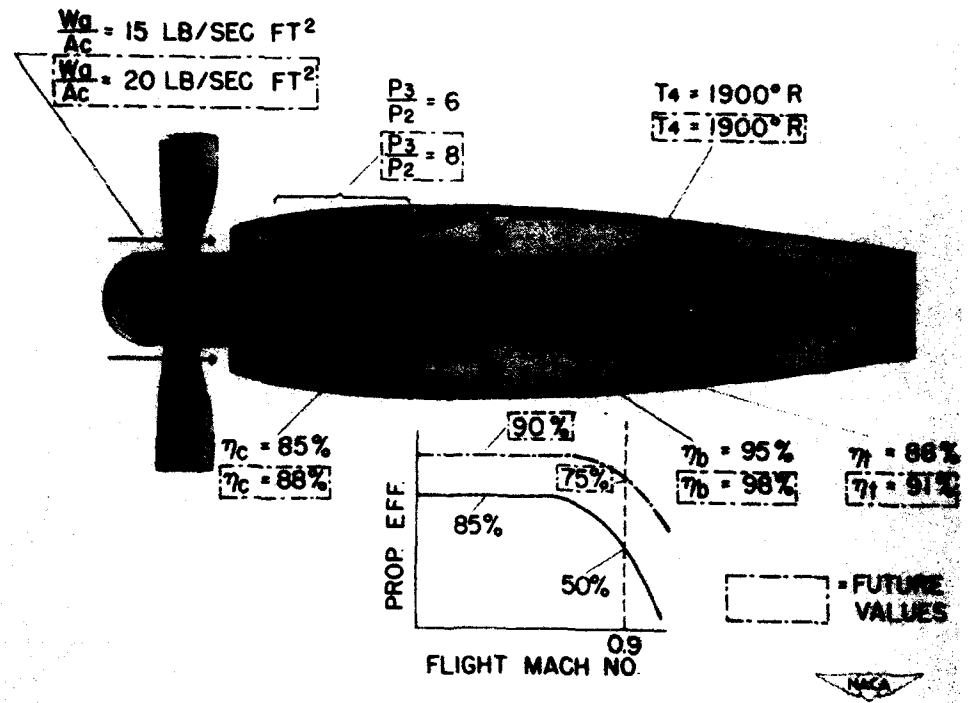

Figure 6

TURBOJET ENGINE ASSUMPTIONS

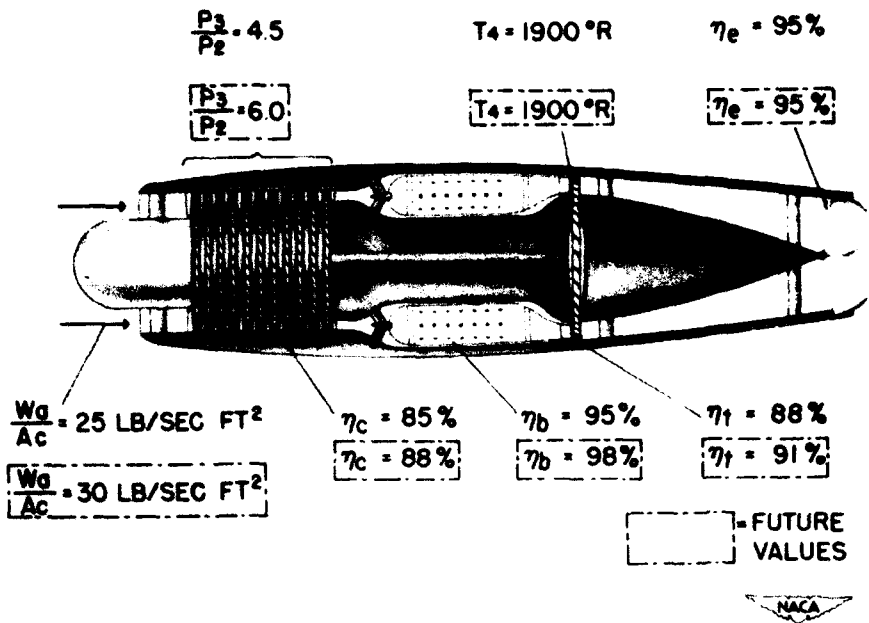

Figure 7

COMPARATIVE RANGE PERFORMANCE OF TURBINE-PROPELLER AND TURBOJET ENGINES

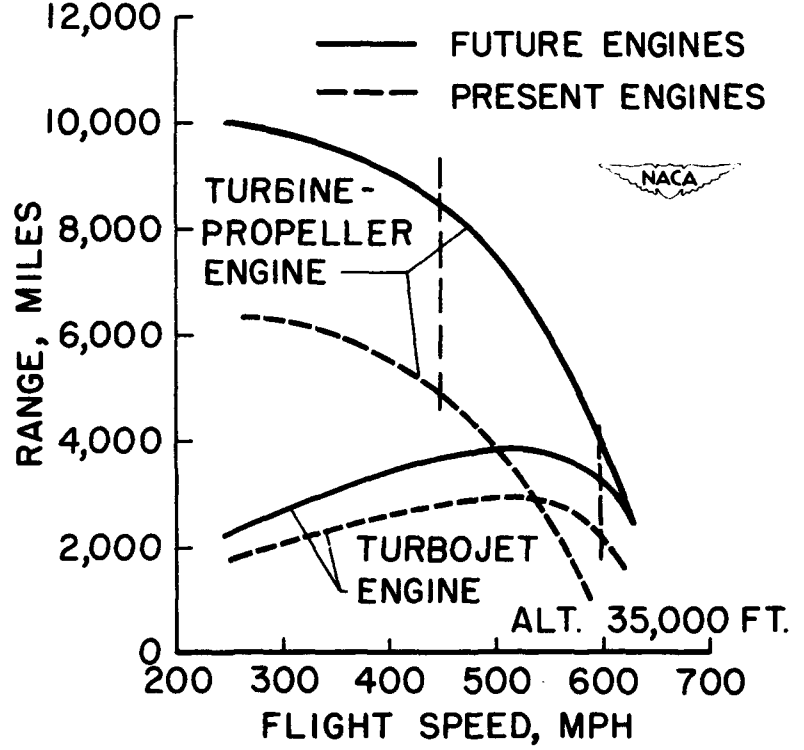

Figure 8

20619

EFFECT OF AMBIENT TEMPERATURE ON TAKE-OFF THRUST

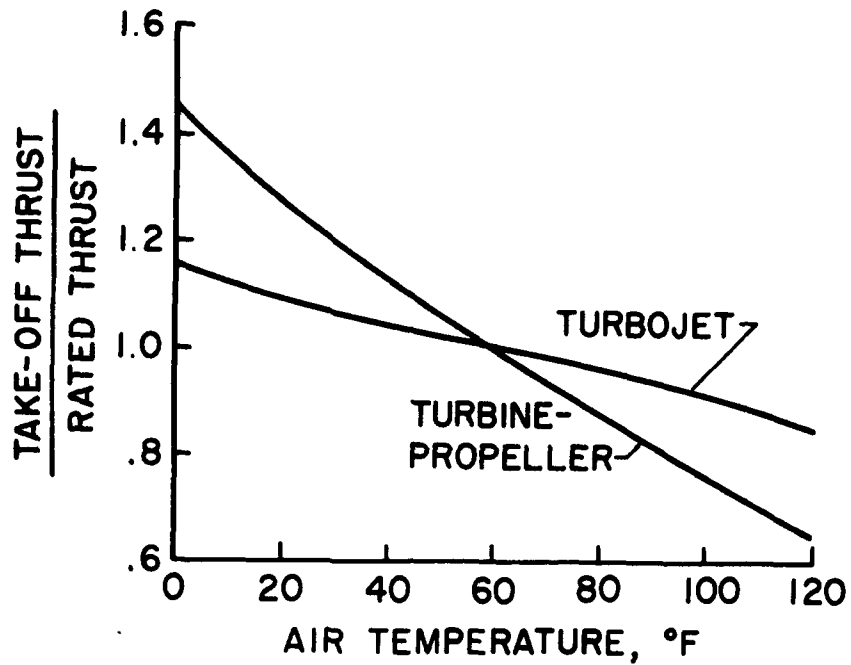

Figure 9

EFFECT OF TAKE-OFF DISTANCE ON RANGE WITH UNAugMENTED ENGINE

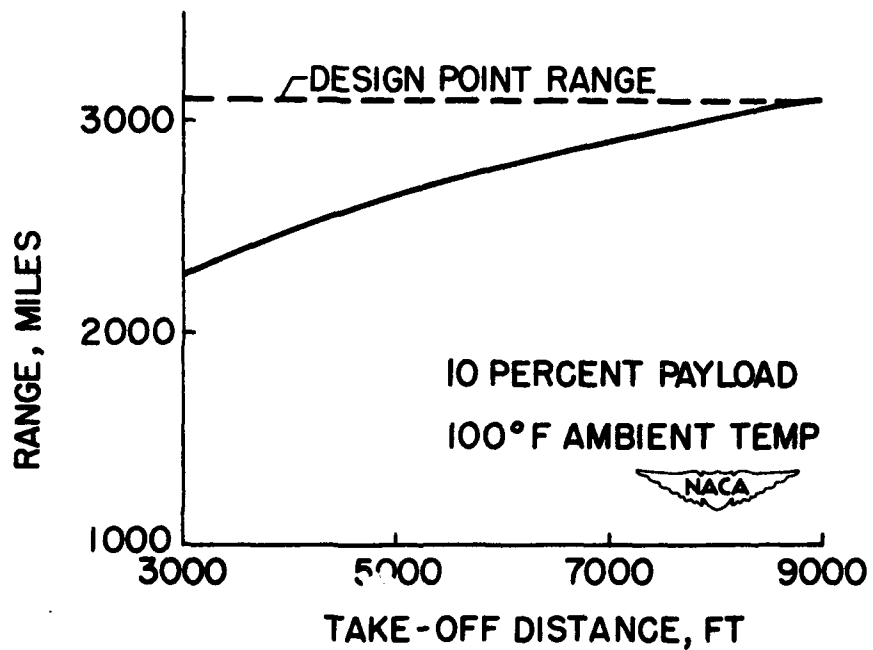

Figure 10

TURBOJET THRUST AUGMENTATION FOR TAKEOFF

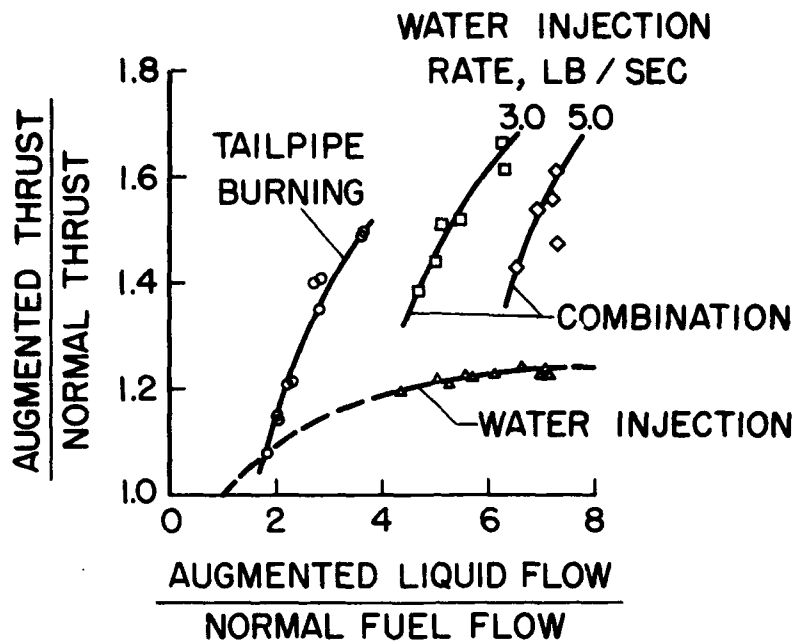

Figure 11

EFFECT OF THRUST AUGMENTATION ON TAKE-OFF DISTANCE

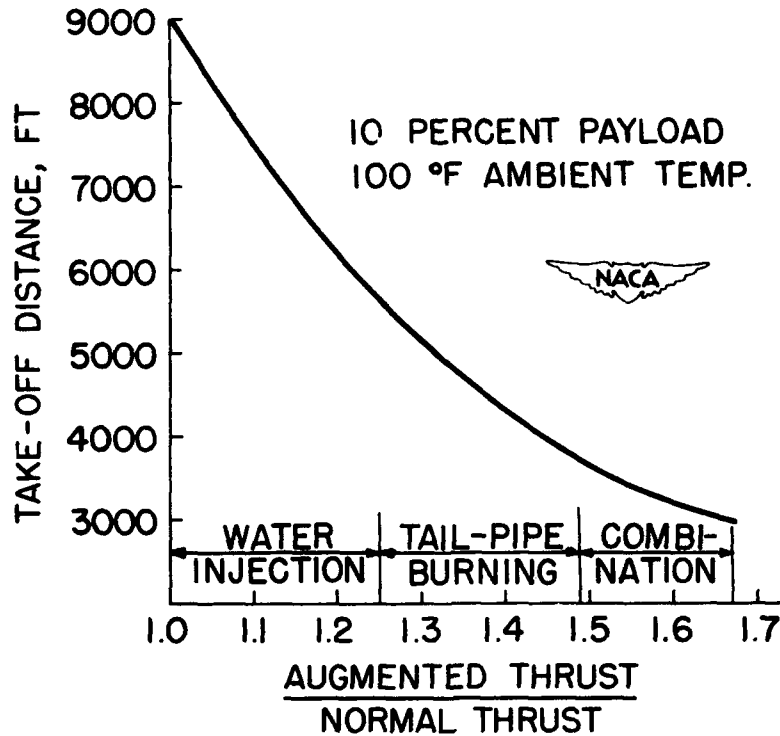

Figure 12

19. OPERATIONAL CHARACTERISTICS OF TURBINE ENGINES

By William A. Fleming and Reece V. Hensley

RESTRICTED

PROPULSION CONSIDERATIONS FOR HIGH-SPEED TRANSPORT AIRPLANES

19. OPERATIONAL CHARACTERISTICS OF TURBINE ENGINES

By William A. Fleming and Reece V. Hensley

Lewis Flight Propulsion Laboratory

The applicability of turbine engines to transport aircraft has been discussed from the aspect of engine and aircraft performance and range characteristics. In addition to these factors, there are a number of engine operational characteristics that have been encountered in operation of turbine engines during the last several years. Some of the operating problems stemming from these engine operational characteristics are reviewed herein with respect to their effect on the operation of transport aircraft.

The operational characteristics that have been encountered and considered to be of main importance are: The altitude operating limits of the engines; the ability to restart the engines during flight at the cruise altitude; possible methods of operating the engine during landing approach, with a view toward maximum thrust reduction with rapid recovery of full thrust in the event of an unsuccessful landing approach; and requirements of an engine-control system for all altitudes. These characteristics pose more severe problems in some engines than in others, and in engines of recent design some of the problems have been essentially eliminated.

Investigations of the altitude operating limits have indicated that the maximum altitude at which a turbine engine will operate is limited by the combustor. As the altitude is increased, the pressure in the combustor becomes lower and thereby adversely affects combustion. As a result, the combustion efficiency decreases at high altitudes until an altitude is reached where the pressure in the combustor is no longer high enough to sustain sufficient burning ahead of the turbine to maintain engine operation and the flame is extinguished.

An example of the altitude operating limits of a current turbojet engine having a compressor pressure ratio of about 4 is shown in figure 1. Operation of this engine at any altitude was possible only over the range of engine speeds between the minimum and maximum-speed-limit curves. With this engine it was possible to

operate at engine speeds as low as the normal idle speed up to an altitude of 38,000 feet. At higher altitudes, the pressure in the combustor at idle speed was too low to sustain combustion. It was therefore necessary to increase the engine speed as indicated by the blow-out limit so as to retain the pressure in the combustor sufficiently high to maintain burning. The decrease in the maximum-speed limit at high altitudes was caused by a reduction in compressor efficiency which is generally encountered at high altitudes and results in a rise in turbine temperature at rated speed; therefore the speed must be reduced at high altitudes to avoid overheating the turbine. Altitude limits are not indicated over the intermediate speed range, inasmuch as these limits were above the altitudes covered in the investigation.

Also illustrated in figure 1 are the probable ranges of cruise and let-down operation. The probable limits of cruise operation are well within the altitude operating limits of the engine. Operation of this engine during let-down at high altitudes would be dangerously close to combustion blow-out.

With continued research and development, the operating limits of most current engines are well above those shown in figure 1. Means for extending the blow-out limits to higher altitudes and consequently to lower burner pressures include modifying the combustor liners to alter the introduction of air into the burning region and using variable-area fuel injectors, which permit operating with higher injection pressures at high altitudes and consequently with better fuel atomization than is obtainable with fixed-area injectors. Also, as the compressor pressure ratio of the engine is raised, the altitude operating limits will be correspondingly extended.

The turbine-propeller engine does not suffer from the maximum and minimum speed or thrust limitations of the turbojet, because it can be scheduled to operate from maximum to minimum thrust at or near rated speed by changing the propeller blade angle. The maximum altitude will be limited by the combustors in the same manner as the turbojet engine. Altitude limits of current turbine-propeller engines are in the vicinity of 50,000 feet or higher.

Another extremely important operating problem, which is under intensive research at the present time, is that of restarting an engine in flight at the cruise altitude. The necessity for restarting the engine may be due to combustion blow-out resulting from malfunctioning of the engine or improper controlling of the engine. Also, it may be either necessary or desirable for best economy to shut down some of the engines during part of the flight. Failure of the engines to restart might require a let-down of as much as 10,000 to 20,000 feet. A subsequent climb to cruise altitude after restarting the engines would result in an undesirable cost in terms of fuel consumption, as well as a loss in time.

The problem of restarting a turbojet engine in flight can be illustrated with the aid of figure 2. Many current engines are of the type shown in figure 2 with a number of tubular combustors. Spark plugs are generally placed in only two of the combustors. Interconnecting tubes provide a path for the flame to travel to the other combustors. Altitude starting can be divided into three steps: ignition, propagation, and acceleration. Ignition is obtained by supplying a combustible mixture of fuel and air in the region of a spark that has sufficient energy to ignite it. Once the fuel is ignited in one or both of the combustors containing spark plugs, conditions must be favorable for the propagation or spreading of the flame through the interconnecting tubes to each of the other combustors. With engines having annular combustion zones, propagation or spreading of the flame is generally no problem.

With the fuel burning in all the combustors, it is then necessary to accelerate the engine from the windmilling starting speed, which may be only 10 to 20 percent of rated speed, to the normal operating speed range. Acceleration must be accomplished without exceeding the turbine-temperature limits or without quenching the flame in the combustors by increasing the fuel flow too rapidly.

In order to illustrate how ignition, flame propagation, and acceleration limits are imposed on a turbojet engine, an example of the altitude-starting limits of one engine investigated is shown in figure 3. Successful starts of the engine could be made only at altitudes below the acceleration-limit curve up to a Mach number of 0.6 and below the propagation limit at higher Mach numbers.

For example, at a Mach number of 0.4 and an altitude of 28,000 feet, burning could be obtained in all the combustors, but the engine could not be accelerated without exceeding the turbine-temperature limits. At a Mach number of 0.7 and an altitude of 35,000 feet, the fuel-air mixture could be ignited in the combustors containing spark plugs; however, the flame would not propagate through the interconnecting tubes and ignite the remaining combustors.

Although starting of this engine was marginal at the cruise altitude of 35,000 feet, some current engines have somewhat higher altitude-starting limits.

A program is now in progress at this laboratory to improve altitude starting. The aim of this program is to raise the altitude ignition and propagation limits to approximately the altitude operating limits. Variables being studied to improve ignition at altitude include the location of the spark in the combustor, the type of spark plug used, the amount of energy dissipated in the spark, and the fuel-spray pattern. The size and location of the interconnecting tubes are being varied to improve propagation or the ability of the flame to spread from combustor to combustor.

Preliminary experiments with single combustors have shown that when the spark energy is increased from the standard value of 0.025 joule to a value of 10 joules, both high and low volatility fuels were ignited at much higher altitudes than those shown in figure 3.

One factor that can limit altitude acceleration is poor combustion. In order to accelerate the engine, the turbine-inlet temperature must be raised. The stability of some combustors at altitude starting conditions is so poor that when the fuel flow is increased to raise the temperature the flame is quenched. With other combustors, an increase in fuel flow at starting conditions results in lengthening of the flame through the turbine into the tail pipe. The additional restriction to the gas flow caused by this burning downstream of the turbine results in a rise in pressure in the tail pipe. Therefore, although limiting turbine temperature may be reached, the available pressure drop across the turbine is insufficient for engine acceleration.

Another factor that can limit altitude acceleration is compressor stall. There is a pressure rise across the compressor accompanying the increase in temperature for acceleration. This increased pressure rise at windmilling starting speeds can stall the compressor blades and result in a speed reduction.

One method for increasing the altitude acceleration limit is by the use of a variable-area exhaust nozzle. When the exhaust nozzle is opened, less restriction is offered to the gases flowing through it and hence the turbine-outlet pressure is lowered. Although gains obtained with the variable-area nozzle are limited, the maximum altitude for engine acceleration has been raised by 5000 to 10,000 feet with this method.

Continued research to improve the combustor performance should permit a further increase in altitude acceleration limits.

The altitude starting problems of the turbine-propeller engine are the same as those for the turbojet engine. When the propeller is geared to the compressor-turbine shaft, the turbine-propeller engine can be windmilled to as high as rated speed with the propeller even at low airspeeds. Ignition and flame propagation would therefore be the only problems in starting at altitude with this type of engine.

During the landing approach it is necessary that the engine thrust be reduced as much as possible; however, the engine must be able to regain rated thrust in 2 to 3 seconds if necessary in order to regain flight speed and altitude in case of an unsuccessful approach. The amount of thrust reduction depends on the aerodynamics of the airplane in the landing configuration, which is discussed in a previous paper.

With the turbojet engine, a considerable thrust reduction is possible during the approach by reducing engine speed, as shown in figure 4. Operation at about 55 percent of rated speed permits a thrust reduction to only 10 percent of the rated value.

Although this thrust reduction is satisfactory for approach, the large mass of the rotor makes the engine inherently sluggish to accelerate when rapid thrust recovery becomes necessary, as shown in figure 5. With the engine operating at 10 percent of rated thrust, about 7 seconds are required to accelerate the engine to rated thrust. In order to keep the acceleration time within the acceptable limits of 2 to 3 seconds, the engine must be operated between 35 and 50 percent of rated thrust during the approach.

One method of obtaining wide thrust control with a greatly reduced time for thrust recovery is by the use of a variable-area exhaust nozzle. Thrust control with the variable-area nozzle is compared to that with a fixed nozzle in figure 6. By increasing the exhaust-nozzle area 50 percent, the thrust at rated speed can be lowered to 40 percent of the rated value. In order to obtain 10 percent of the rated thrust, the speed need then be reduced only to 77 percent of rated speed as compared to 55 percent of rated speed with the fixed nozzle.

Thrust recovery from this higher speed is then much more rapid as shown in figure 7. Recovering from 40 to 100 percent of rated thrust by closing the exhaust nozzle requires only about 1/2 second as compared to 2 1/2 seconds by varying speed with a fixed-area nozzle. Furthermore, the time required to increase the thrust from 10 to 100 percent of the rated value requires only 2 seconds with the variable-area nozzle as compared to about 7 seconds with the fixed nozzle.

Other methods of thrust reduction for landing approach are: bleeding air from the compressor, throttling the engine inlet, and diverting the exhaust jet sideways or forward with jet-thrust spoilers.

There is essentially no thrust-control problem with the turbine-propeller engine inasmuch as the engine can be scheduled to operate from reverse to maximum thrust at or near rated speed by propeller-blade-angle changes.

Considerable trouble has been experienced at high altitudes with control systems of some turbine engines. Most engine controls are designed to operate at sea level. Difficulties arise, however, when the controls are taken to altitude because of the increased acceleration time of the engine, which is referred to as an increase in time constant. The time constant of the control must be changed accordingly to avoid instability. An example of operation with a control that has not been properly compensated for a change in engine-time constant is compared in figure 8 with a control that was properly compensated.

The dashed line in figure 8 indicates the change in set or desired speed as the control lever is advanced. The uncompensated control had previously been operated satisfactorily at sea level. When the control lever was advanced at 25,000 feet, the control response in supplying fuel flow was the same as that at sea level. That is, the control anticipated the same acceleration as at sea level, whereas the actual acceleration required about three times as long. Because the acceleration was slow, the control called for more fuel to hasten the acceleration. The result was an acceleration with excessively high turbine temperature followed by a severe overshoot beyond the set speed. The control, anticipating a quick response in speed as at sea level, then gave the signal to reduce fuel flow. Since the engine response was slow, the fuel flow was decreased too much. An under shoot below the set speed then occurred. The control continued to increase and decrease the fuel flow, resulting in undamped overshoots and undershoots. Such operation could readily lead to engine destruction and was stopped by shutting down the engine.

The compensated control was set to anticipate a slower acceleration response at altitude. The fuel flow was therefore increased more slowly. This acceleration was slower and within the allowable temperature limits. As the control anticipated the slower acceleration response at altitude, only a slight overshoot and undershoot, which were damped out after the first cycle, occurred.

Because the turbine engine must be operated within a narrow range of conditions for maximum economy, the control must be able to accurately hold the set condition. Also, because the operating conditions for maximum economy are near the operating limits of the engine, the control must be very sensitive to overspeed and overtemperature conditions to prevent overheating the turbine blades or overspeeding the rotor for any length of time.

It is also desirable to have a control that will operate with a single lever that has a fixed schedule at all altitudes. That is, to have altitude compensation built into the control so that at all altitudes a given control-lever position corresponds to a given percent of rated thrust for the turbojet engine or percent of rated power for the turbine-propeller engine. This relation between control-lever position and power level becomes extremely difficult to obtain because the fuel flow at cruise is only one-fourth to one-sixth of the fuel flow at take-off.

A number of current turbine engines now under development have controls that approach these requirements; however, much remains to be accomplished before the control system can be completely relied upon to meet the demands imposed on it. Studies of a number of engine types are being carried on to utilize the engine characteristics in the analysis of controls and thereby determine the basic factors leading to improved control reliability.

In conclusion, solutions to some of the engine operating problems are currently available and research is being continued to eliminate the other problems that still exist. It should be kept in mind that the demands of the military on these engines are in most respects more severe than those for transport application. Therefore, because these engines are being used and will continue to be used even more widely in military aircraft before they find their way into transport application, many of the problems will be solved for the military. The result will be that, as in the past, solutions to the most important problems will be available when the engines are finally used by the transport industry.

2025

EXAMPLE OF TURBOJET-ENGINE OPERATING LIMITS

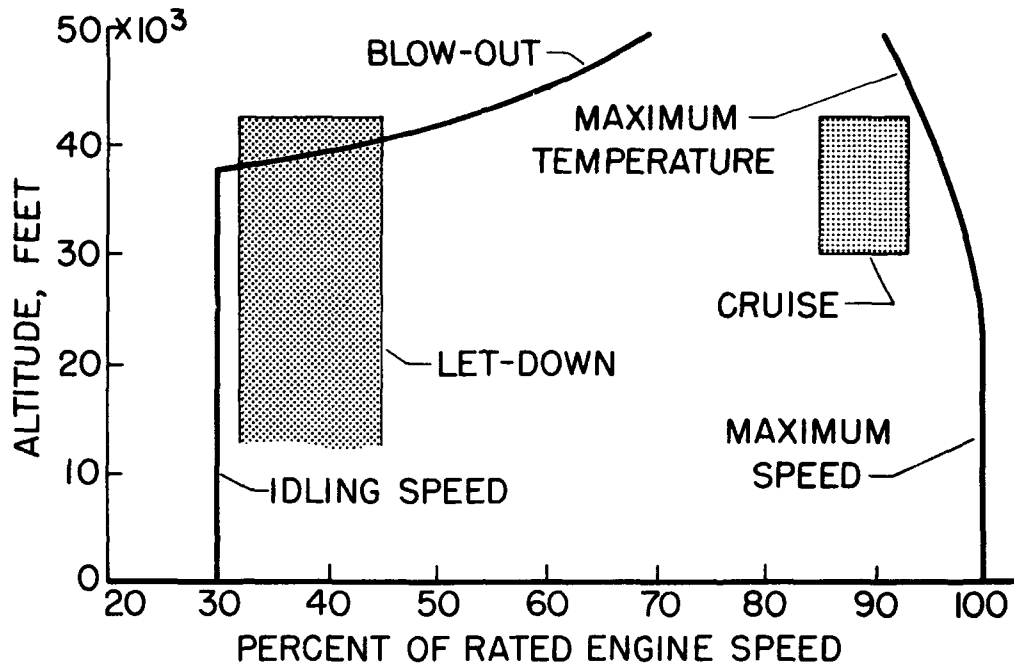
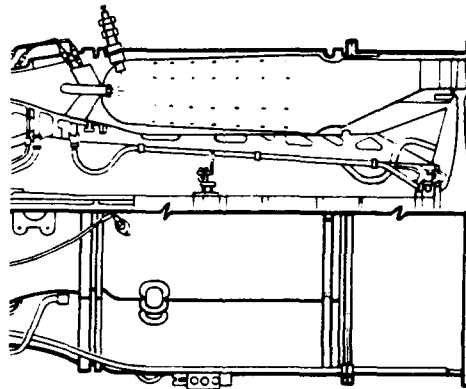

Figure 1

STEPS IN ALTITUDE STARTING



- 1- IGNITION
- 2- PROPAGATION
- 3- ACCELERATION



Figure 2

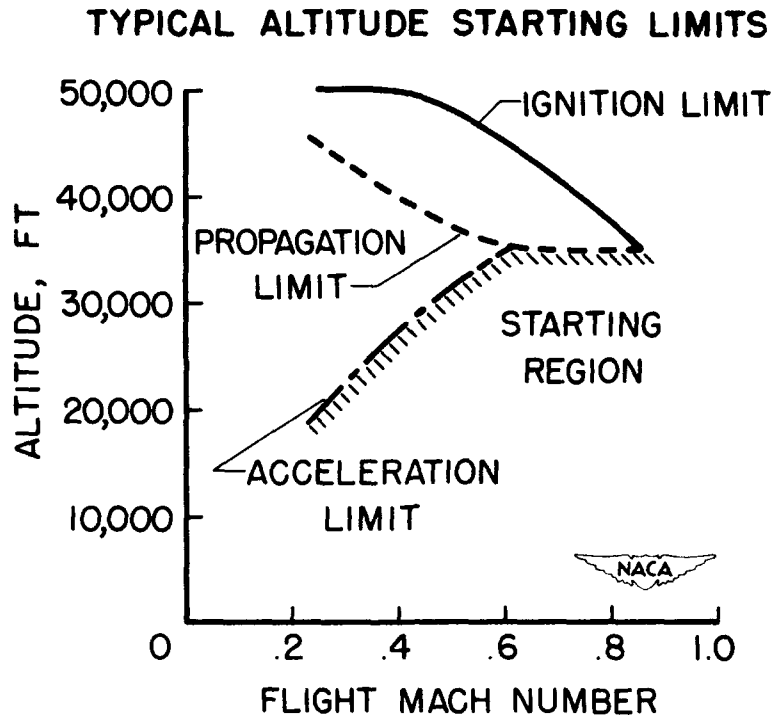

Figure 3

THRUST CONTROL WITH FIXED NOZZLE SEA LEVEL 150 MPH

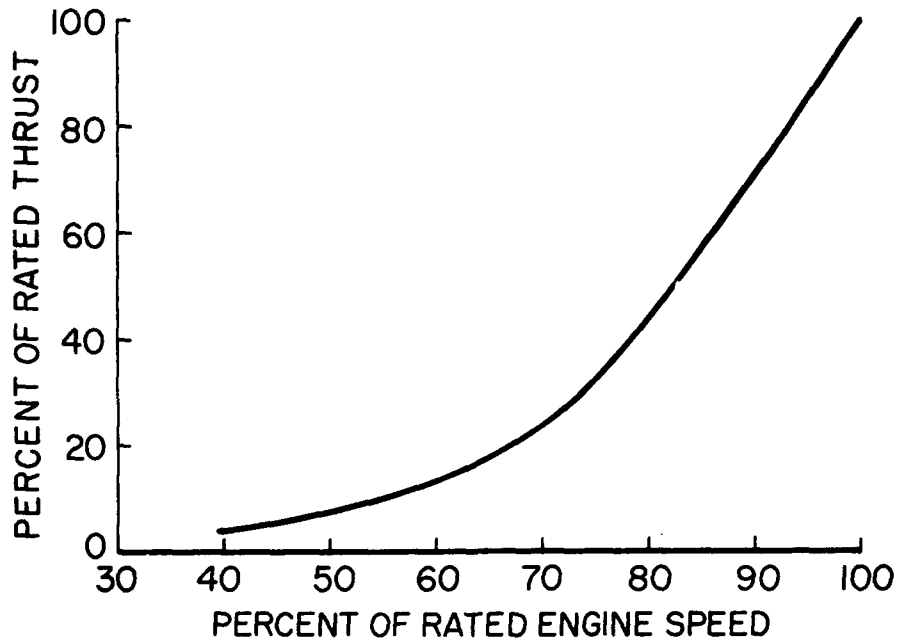

Figure 4

THRUST RECOVERY WITH FIXED NOZZLE
SEA LEVEL, 150 MILES PER HOUR

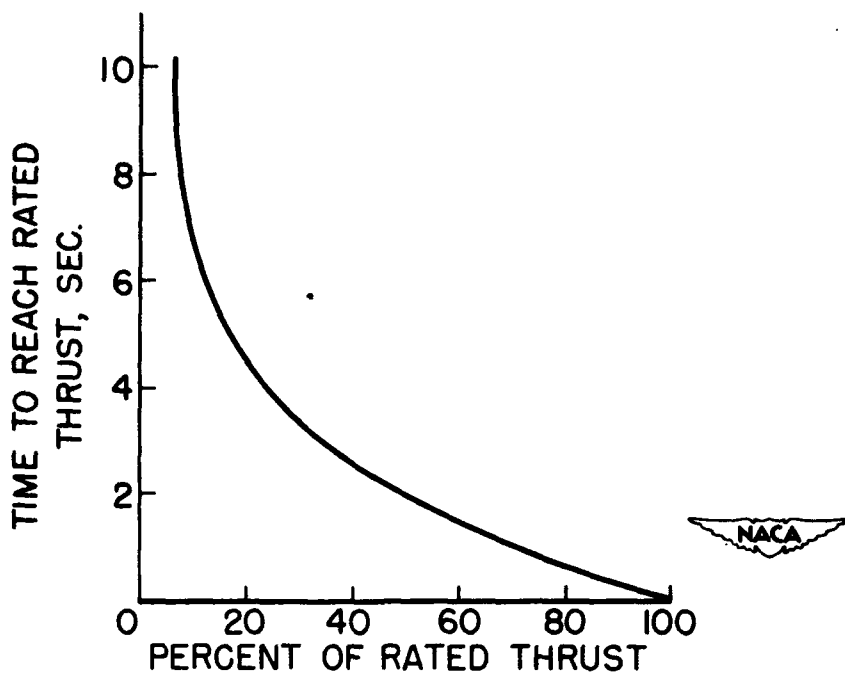

Figure 5

THRUST CONTROL WITH FIXED AND VARIABLE NOZZLES
SEA LEVEL, 150 MILES PER HOUR

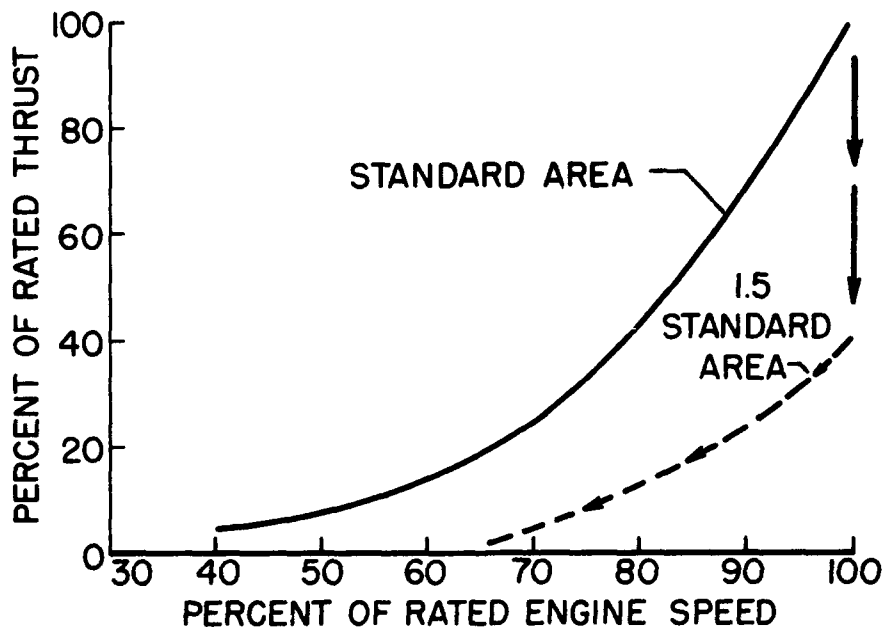

Figure 6

THRUST RECOVERY WITH FIXED AND VARIABLE NOZZLES
SEA LEVEL 150 MPH

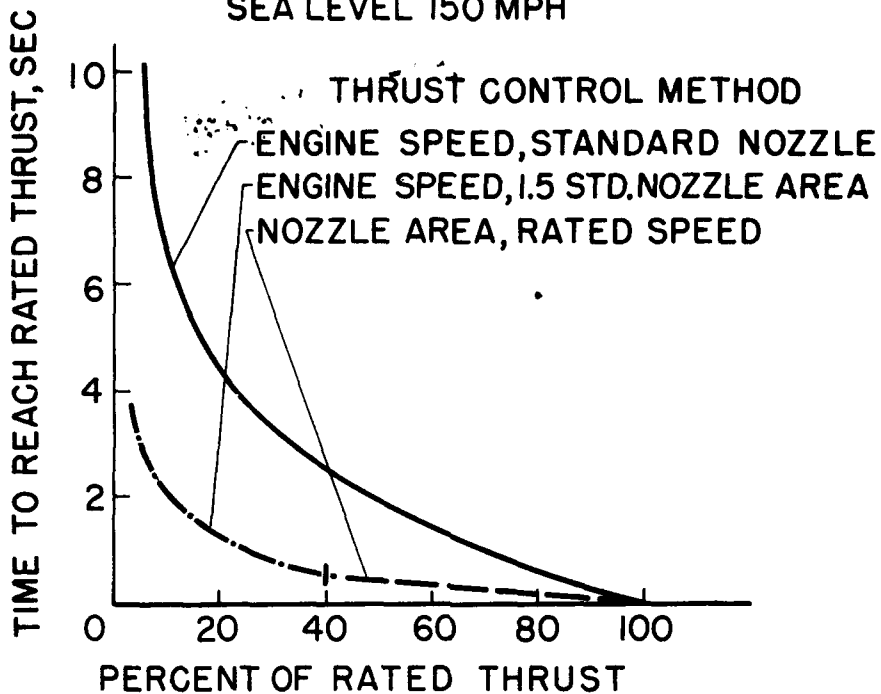

Figure 7

EXAMPLE OF CONTROL INSTABILITY
ALTITUDE, 25,000 FT

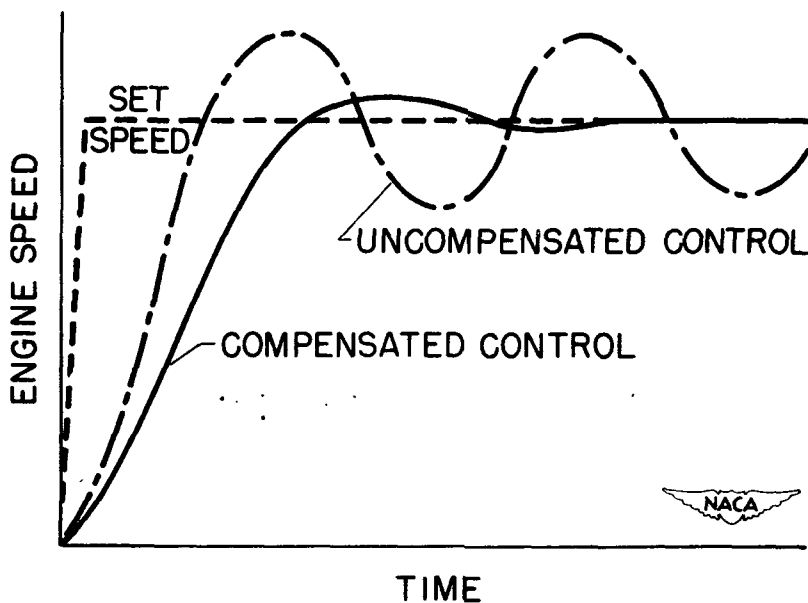

Figure 8