

ADA 279508

WHOI-93-21

In Situ Measurements of the Dynamics
of
A Full Scale Bottom Moored Mine Model

by

H.O. Berteaux, A. Bocconcelli, C. Eck and S. Kery

Woods Hole Oceanographic Institution
Woods Hole, Massachusetts 02543

June 1993

Technical Report

Funding was provided by the Naval Surface Warfare Center
under Contract No. N60921-91-C-0216.

Reproduction in whole or in part is permitted for any purpose of the United States
Government. This report should be cited as Woods Hole Oceanog. Inst. Tech. Rept.,
WHOI-93-21.

Approved for public release; distribution unlimited.

Approved for Distribution:

George V. Frisk
George V. Frisk, Chair
Department of Applied Ocean Physics
and Engineering

Accession For	
NTIS CRA&I	<input checked="" type="checkbox"/>
DTIC TAB	<input checked="" type="checkbox"/>
Unannounced	<input type="checkbox"/>
Justification	
By	
Dist. istribution /	
Availability Codes	
Dist	Avail and / or Special
A-1	

IN SITU MEASUREMENTS OF THE DYNAMICS

of

A FULL SCALE BOTTOM MOORED MINE MODEL

by

H.O. BERTEAUX, A. BOCCONCELLI, C. ECK, S. KERY

**Woods Hole Oceanographic Institution
Woods Hole, Massachusetts 02543**

TABLE OF CONTENTS

ABSTRACT	5
ACKNOWLEDGMENTS	6
INTRODUCTION	7
BACKGROUND:	7
OBJECTIVES:	7
CAPTORDYN EXPERIMENTAL SET UP	10
SYSTEM COMPONENTS:	10
Position Monitoring Network:	10
Current Monitoring Instrument:	10
CAPTOR Body:	10
Mooring Line:	10
Anchor Module:	11
Electro-Optical-Mechanical (EOM) Cable:	11
Surface Mooring:	11
SYSTEM INSTALLATION:	11
MECHANICAL DESIGN	15
MOORING DESIGN:	15
CAPTOR BODY ADAPTATIONS:	15
Slip Ring Assembly	15
ANCHOR MODULE:	16
MOORING CABLE:	19
Oil Filled Hose	19
Cable Connection Design:	22
Electrical Harness	22
BOTTOM EOM CABLE	26
MECHANICAL DRAWINGS AND DOCUMENTATION	26
ELECTRICAL DESIGN	28
GENERAL CONFIGURATION	28
CAPTOR AND TETHER POSITIONS MONITORING SYTEM:	29
TENSION MONITORING SYSTEM:	31
STRUMMING MEASUREMENTS:	32
CURRENT MEASUREMENTS:	33
ANCHOR ELECTRONICS:	34
SHIPBOARD ELECTRONICS:	35
ELECTRICAL SCHEMATICS AND DOCUMENTATION:	35
EXPERIMENTAL RESULTS	36
EXPERIMENTAL DIFFICULTIES:	36
Sharps:	36
Accelerometers:	37

ACCOMPLISHMENTS: 37

CONCLUSION 39

REFERENCES 40

APPENDICES 41

APPENDIX A: Mechanical Design Documentation 41

SLIP RING ASSEMBLY 41

CABLE CONNECTION ASSEMBLY 52

MOORING CABLE TEST REPORT 58

APPENDIX B: Electrical Design Documentation 66

LIST OF FIGURES

Figure 1: DYNAMOOR Array	9
Figure 2: CAPTORDYN Experimental Setup	12
Figure 3: CAPTOR Body Dimensions	13
Figure 4: CAPTOR Mooring, Static Analysis	17
Figure 5: Slip Ring Assembly	18
Figure 6: Anchor Module	20
Figure 7: Mooring Cable General Assembly	21
Figure 8: Mooring Cable Attachment	23
Figure 9: Mooring Cable, Internal Layout	24
Figure 10: Bottom EOM Cable	27
Figure 11: CAPTORDYN Electrical Block Diagram	30

ABSTRACT

Under the sponsorship of the Naval Surface Warfare Center (NSWC), Dalgren Division, White Oak, Maryland, the Ocean Systems & Mooring Laboratory of the Woods Hole Oceanographic Institution devised (1991) and conducted (1992) an experiment to measure the dynamic response of a full scale model of the CAPTOR mine, submerged and moored in strong tidal currents near Woods Hole, MA.

Specifically, the purpose of this sophisticated engineering experiment was to obtain long term, high frequency measurements of the spatial position of the CAPTOR body, of the tension at both ends of the mooring line, and of the mooring line strumming, as a function of the currents prevailing at the site.

This report first describes the main components and the method of deployment of the complex CAPTOR Dynamics Experiment (CAPTORDYN) set up. It then presents the mechanical and electrical designs of the entire system. Finally a review of the results obtained concludes the report.

ACKNOWLEDGMENTS

The CAPTOR Dynamics Experiment (CAPTORDYN) project greatly benefitted from the technical support of P. O'Malley, Senior Research Technician, who assembled and tested most of the electromechanical components of the system. He also prepared and helped deploy and recover the moorings.

The intricate installation, planned and directed by A. Bocconcelli, was successfully completed thanks to the skilled assistance of Dan Clark, marine contractor, and his crew. The captains of the different boats participating in the operation must also be acknowledged, in particular D. Olmsted, captain of R/V ASTERIAS, S. O'Malley, operator of R/V MYTILUS, and Charlie Mitchell, captain of the R/V JAGUAR. The professional assistance of the WHOI divers, under the leadership of S. Kery, was crucial and flawless. Our thanks also go to Dr. E. Terray of WHOI for his patience and help in setting up the ADCP and in the downloading and reconstruction of the data.

The authors wish to thank Tegore Sommers of Marquest, Inc, and his staff for their valuable assistance in modifying the standard SHARPS software for our use and help in getting the system running. The exceptional support of Dr. W. Paul, of Martin Marietta, Aero & Naval Systems Division, in developing, testing, and timely providing the unique mooring line hoses must also be acknowledged.

The supportive participation to the preparation, deployment, and post cruise activities of M. Kumagai, G. Winkler, H. Steves, B. Park, and D. Myers, all members of NSWC, was most welcome.

W. Liberatore and B. Doherty provided precious assistance with the writing and the illustration of this report.

Finally, the personal interest and continued support of Mark Kumagai, NSWC project manager, are greatly appreciated.

The CAPTORDYN experiment was performed under Naval Surface Warfare Center Contract # N60921-91-C-0216.

INTRODUCTION

BACKGROUND: In 1990 the Ocean Systems & Mooring Laboratory, Woods Hole Oceanographic Institution, received funds from the Office of Naval Research to design, build, and deploy an experimental mooring equipped with sensors to monitor and record the dynamic response of a spherical subsurface buoy moored in strong currents. This experiment, named DYNAMOOR, is depicted in Fig. 1. DYNAMOOR was deployed June 24, 1991 in Vineyard Sound, on the east side of Naushon Island, approximately three miles from the WHOI dock. The site is a deep trench (90 ft.) where strong (up to 3 knots), cyclic, tidal currents prevail. The mooring was recovered July 1, 1991. Results from the DYNAMOOR experiment have been documented in a recent paper [1].

The technology developed for DYNAMOOR was expanded to suit the more ambitious goals of the CAPTOR Dynamics Experiment (CAPTOR DYN).

OBJECTIVES: The set of measurements to be made in situ, for CAPTOR DYN included:

- Quasi simultaneous, repeated (5 Hz) space location (± 2 cm) of two end points of the CAPTOR body, which could permit to describe its 3 D spatial translation and rotation as a function of time.
- Space location, with frequency and resolution as above, of a point on the mooring line, one third down from the buoy.
- Mooring line tension at both ends of the mooring cable.
- Mooring line vibration (20 Hz) in three orthogonal directions, measured at three different nodes along the length of the mooring cable.

In addition, the current profile at the site had to be constantly monitored with the help of an Acoustic Doppler Current Profiler (ADCP). To accommodate the fast sampling rates and the ensuing large volume of data, the measurements were to be transmitted to a shore station via a bottom mounted, electro-optical-mechanical (EOM) cable, previously used in DYNAMOOR.

The deliverables to NSWC specified in the WHOI proposal, included the hardware specifically procured and the software specifically developed for the CAPTORDYN, files of all the data recorded, and this final report.

CAPTORDYN was installed at the DYNAMOOR site on June 25, 1992. After three days on station, the mooring was entirely and successfully recovered on June 27, 1992.

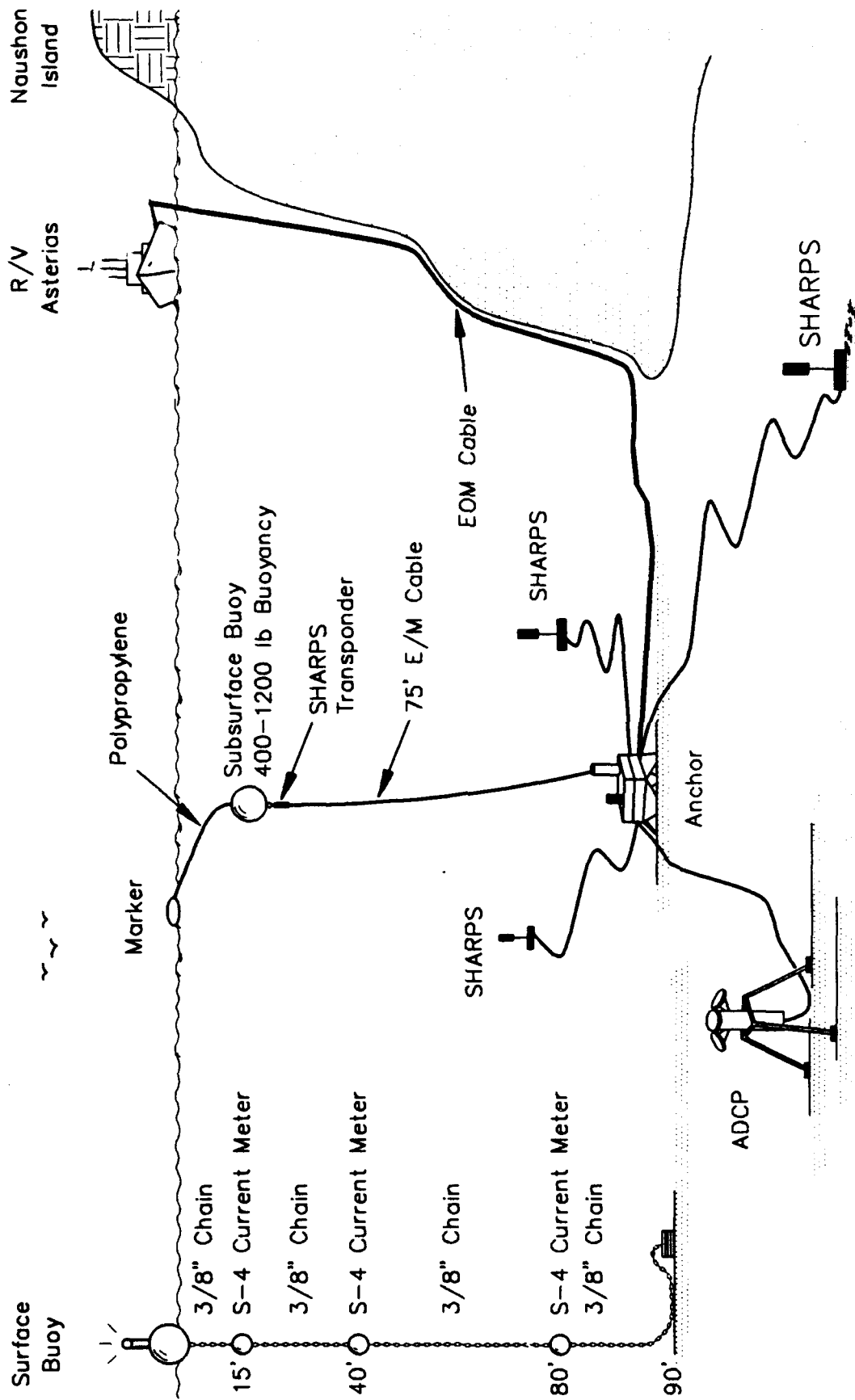

Fig. 1 DYNAMOOR Array

CAPTORDYN EXPERIMENTAL SET UP

SYSTEM COMPONENTS: The experimental set up, as deployed, is schematically presented in Fig. 2. A brief description of the principal components follows.

Position Monitoring Network: A Sonic High Accuracy Ranging and Positioning System (SHARPS) was used to monitor the motions of the CAPTOR body. This system was conceived for precise underwater tracking at high update rates in high multipath environments. The SHARPS network used consisted of a set of compact underwater acoustic transceivers, each independently capable of transmitting or receiving high frequency acoustic pulses. The CAPTORDYN experimental set up used six such transceivers - one "Master" located on the CAPTOR body itself, two "Masters" located on the mooring line, and three "Slaves" installed on the bottom.

Current Monitoring Instrument: An Acoustic Doppler Current Profiler (ADCP) which uses the Doppler principle to remotely measure speed and direction of moving water masses. The 600 KHz ADCP was mounted on a steel frame and installed on the bottom by divers at 60 m from the anchor module. This instrument is fully described in Appendix C.

CAPTOR Body: The capsule of a CAPTOR mine MK 60 Mod 1, properly ballasted and equipped with a stabilizer arm [2], was provided to the OS&M Lab by NSWC. This full scale model was in the shape of a slender cylinder, with dimensions, weight and displacement as shown in Fig. 3. The CAPTOR was equipped with a swivel mounted on its lower face.

Mooring Line: The mooring line consisted of a 65 ft. long 1.14 in. diameter, Vectran^R fiber reinforced polyurethane hose with a nominal tensile strength of 19,800 lbs. Three small accelerometer packages, and considerable cabling to transmit power and signals between the CAPTOR body, the inserted sensors, and the anchor module, were mounted inside the hose. A SHARPS transducer was attached outside the hose, at one third the length of the hose down from the CAPTOR body. The hose was terminated at both ends by swaged fittings and mechanically and electrically connected to tension cells, one at the CAPTOR body, one at the anchor module end. The hose was oil filled. The fully instrumented mooring line weighed 47.45 lbs in air and 14.9 lbs (negative) in fresh water.

Anchor Module: A 3500 lb (1590 kg) anchor module maintained the mooring on station. Six cables were connected to the anchor module: the mooring line, the three bottom SHARPS transponder cables, the ADCP cable and the EOM cable. A large pressure case mounted on the anchor frame housed the power regulators and the data formatting and telemetry electronics.

Electro-Optical-Mechanical (EOM) Cable: The 850 m long EOM cable was deployed on the sea floor and used to connect the array to the field laboratory located on the R/V ASTERIAS, moored near the island shore.

Surface Mooring: An all chain surface mooring, instrumented with three InterOcean current meters (see Appendix C), was deployed near the CAPTOR array. Its purpose was to serve as a site marker and to provide redundant current measurements to back up the ADCP.

The design and the performance of the various components of the CAPTOR array are presented in details in the following section.

SYSTEM INSTALLATION: CAPTORDYN was deployed June 25, 1992, in waters close to Woods Hole in a flat, 90 foot (27.5 m) deep trench where strong (up to three knots) cyclic tidal currents prevail. CAPTORDYN and the marker moorings were recovered on June 27, 1992.

A 90 foot (30 m) long barge equipped with a trawl w, jack-up system, lifting crane and two capstans was used for the deployment. The CAPTORDYN main components, including the S4 mooring, were loaded on the barge, together with the EOM cable wound on its lowering w. The barge was assisted by two tugboats (JAGUAR and CIGANA). The R/V ASTERIAS was used both to deploy the ADCP and then as a field lab. The R/V MYTILUS and an inflatable boat (Zodiac) were also employed to assist the diving operations.

The mooring was deployed during slack tide to ease station keeping, diving, and avoid anchor dragging and mooring entanglement. A marker buoy connected by a polypropylene line (100 ft long, 1/2 in. diameter) to the CAPTOR body was eased overboard and passed to the R/V MYTILUS. The CAPTOR body was then launched by the barge crane and the mooring hose was paid off by hand at the same time. During this operation the R/V MYTILUS kept the CAPTOR marker line in tension preventing the mooring from entangling with the tugboat.

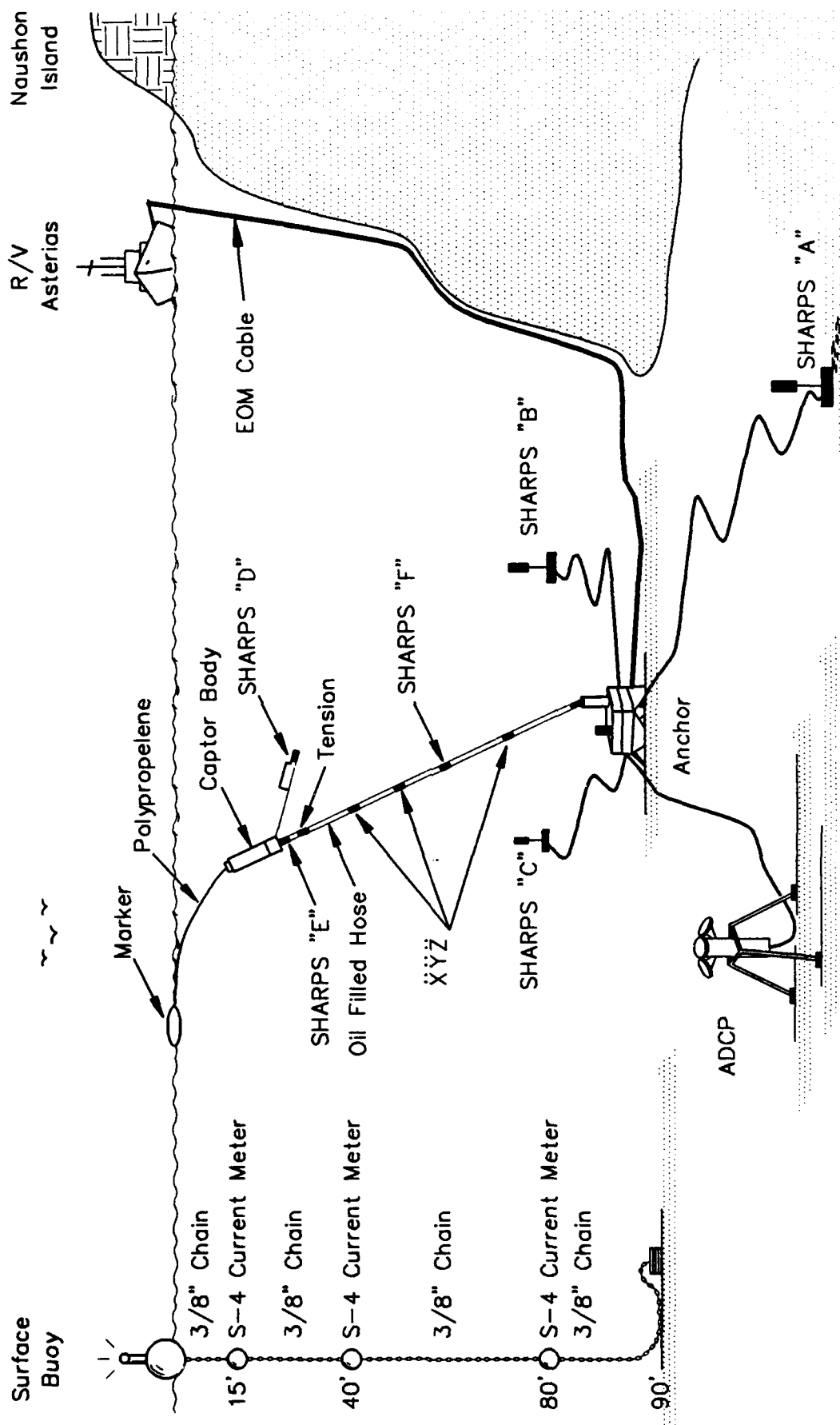

Fig. 2 CAPTORDYN Experimental Set Up

TEST VEHICLE: C1-001

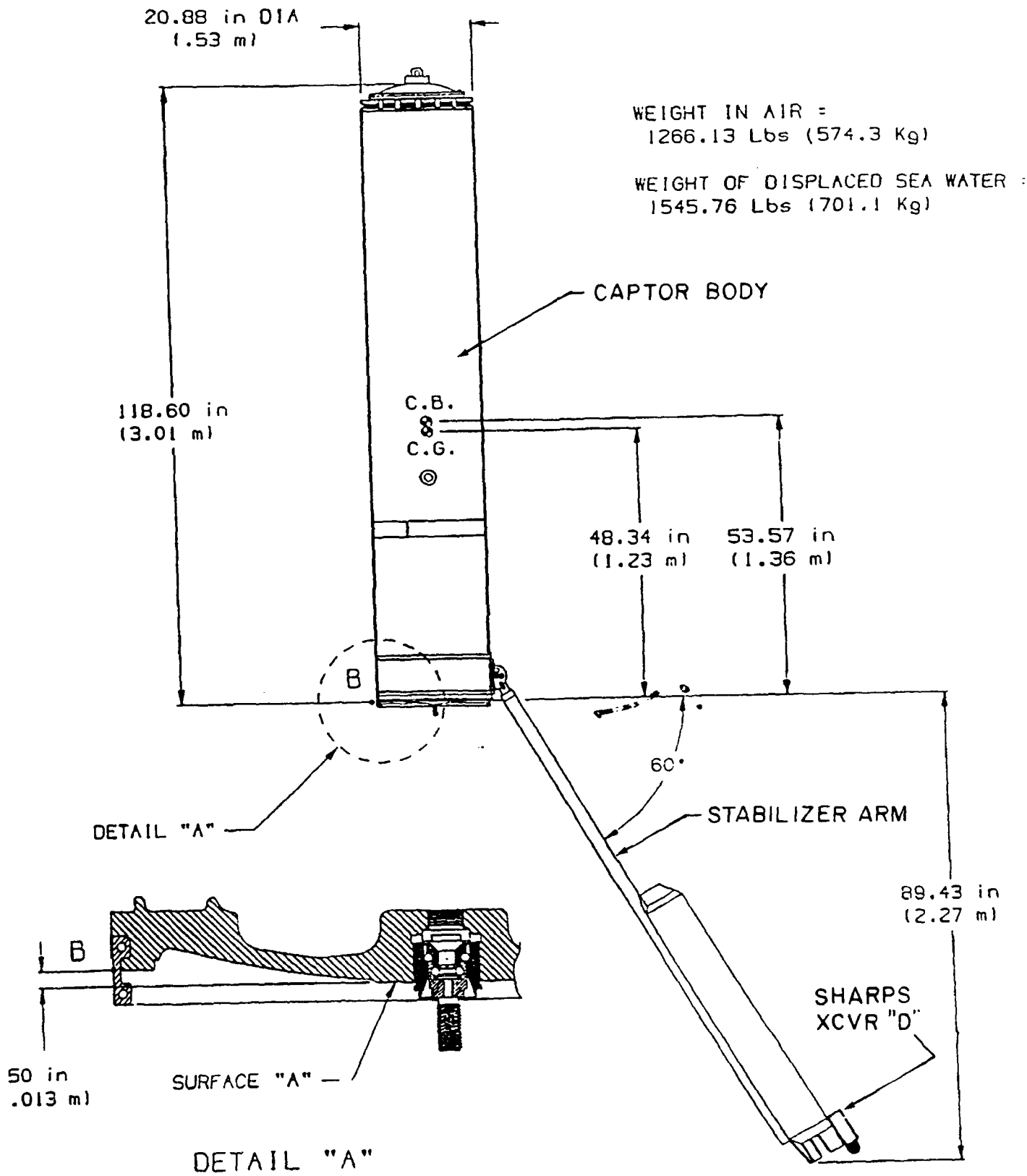

Fig. 3 CAPTOR Body Dimensions

Next the anchor module, with three SHARPS coiled on the frame and all electrical/optical connections made and checked, was slowly lowered by the crane with the help of a nylon bull rope. At the same time the ADCP ground cable (300 ft long) was paid off from the R/V ASTERIAS. The EOM cable was simultaneously paid off from the w, with no tension on it, and married to the bullrope.

Once the anchor module reached the bottom, the lowering nylon rope was tied to the EOM cable and cast off from the barge. At this point two divers from the R/V MYTILUS dove on the anchor module to check the anchor position and the mooring cable (hose) path. With anchor and cable in good standing the divers dove a second time in order to deploy the SHARPS array on the bottom and open up the stabilizer arm on the CAPTOR body. Upon completion of the diving operations the ADCP was deployed from the R/V ASTERIAS.

With all sensors deployed on site, the barge was towed towards the shore, paying off the EOM cable. The R/V ASTERIAS was already positioned near shore in the chosen spot for the field lab. Once the barge was close enough to the ASTERIA the jacks were lowered to hold it firmly in position. The EOM cable shore end (with the fiber optic terminations) was transferred to the R/V ASTERIAS and connected to the monitors and controller. The CAPTORDYN was promptly energized and a first electrical test was performed. The barge was then moved back offshore in order to deploy the S4 mooring in the pre-determined position (100 m to the west of the CAPTOR anchor). The S4 mooring was assembled on the barge and then deployed, anchor first. Two tugboats held the barge in position against a two knot current. The recovery was achieved by reversing the order of the deployment sequence.

MECHANICAL DESIGN

Important features of the CAPTORDYN experiment mechanical design are hereafter summarized.

MOORING DESIGN: Accurate predictions of the depth reached by the CAPTOR body and of the tension in the mooring line as a function of increasing currents were needed to properly select the range of the tension cells, the strength of the mooring hose, and the weight of the anchor. The trajectory of the tension in the mooring line for three current profiles were obtained with the help of the computer program SSMOOR [3]. Current profiles and corresponding mooring trajectories are shown in Fig. 4.

CAPTOR BODY ADAPTATIONS: The CAPTOR body was received from NSWC on March 10, 1992. Some modifications were necessary to prepare the full scale model for the experiment. These modifications, which were designed to be temporary and have a minimum impact on the body structure, included: small brackets to mount the SHARPS transducers and a slip ring assembly, hereafter described.

Slip Ring Assembly: The tide changes direction by 180 degrees every six hours and the stabilizer causes the CAPTOR to orient to the flow. A ball bearing swivel built into the base of the CAPTOR (Fig. 3) allows this rotation under normal operating circumstances. The electrical conductors for the two SHARPS transducers had to be routed past this swivel and into the top of the oil filled mooring hose. This necessitated the development of a slip ring assembly to prevent the conductors from twisting and ensure electrical continuity as the CAPTOR rotates around its point of attachment.

The slip ring assembly is conceptually depicted in Fig. 5. Drawings of the actual components are included in Appendix A, "Mechanical Design Documentation." Briefly described, the slip ring assembly consists of a non-rotating subassembly or stator which supports four slip rings and the rotor subassembly which supports the spring contacts riding on the slip rings as it rotates around the stator.

At its upper end the stator body is screwed and pinned to the 3/4 - 10 thread extending from the ball bearing swivel mounted on the base of the CAPTOR body. The lower end of the stator forms a clevis. The pad eye of the top tension cell is

secured to this clevis. The tension cell in turn is attached to the hose through the hose end fittings. Thus the stud, the stator, the tension cell, and the mooring line upper termination form a rigid assembly around which the CAPTOR body, solicited by its stabilizer arm, rotates.

The rotor body is bolted to the base of the CAPTOR body. Its body contains an oil filled cavity. The top and bottom faces of the rotor ride against teflon BAL seals which insure leak tightness, containing the oil and keeping the seawater out.

Two coax cables, one for each of the two SHARP transceivers mounted on the CAPTOR, penetrate the rotor through stuffing tubes. Their four conductors are soldered to the spring contacts. The four conductors of the two outgoing coax cables are individually soldered to the four copper slip rings. These cables leave the stator body through stuffing tubes to connect into the hose electrical bulkhead.

ANCHOR MODULE: The anchor module (Fig. 6) was designed to resist current induced forces and any overturning moment caused by the tension in the mooring cable. An anchor weight of 3500 lbs in air, 3040 lbs in seawater, was selected. A 1/2 in. thick steel deck plate, two cast iron discs and a hexagonal, 1/2 in. thick, steel plate with six large, bottom grabbing flukes made up the base. These were joined together with a 1 1/4 in. central steel bolt.

The mooring attachment was located 34 in. above the bottom, at the end of a heavy wall steel pipe. This prevented the mooring from tangling with anything else on the anchor.

The EOM cable termination and pear ring used to lift the anchor, were located on the deck plate, opposite the mooring attachment pipe. The separation effectively prevented the two cables from tangling during deployment.

A 12 in. diameter pressure case, 30 in. long, was mounted on the deck, perpendicular to and between the two cable attachment points. One end of the case has an oil filled box in which the EOM cable core terminates. The other end cap has bulkhead connectors for the SHARPS cables, the ADCP cable and the signal and power conductors for the mooring cable electronics.

Two other vertical pipes were welded to the anchor base to support a triangular frame enclosing a wire mesh deck. Gussets between this frame and the mooring attachment pipe provide added bending strength.

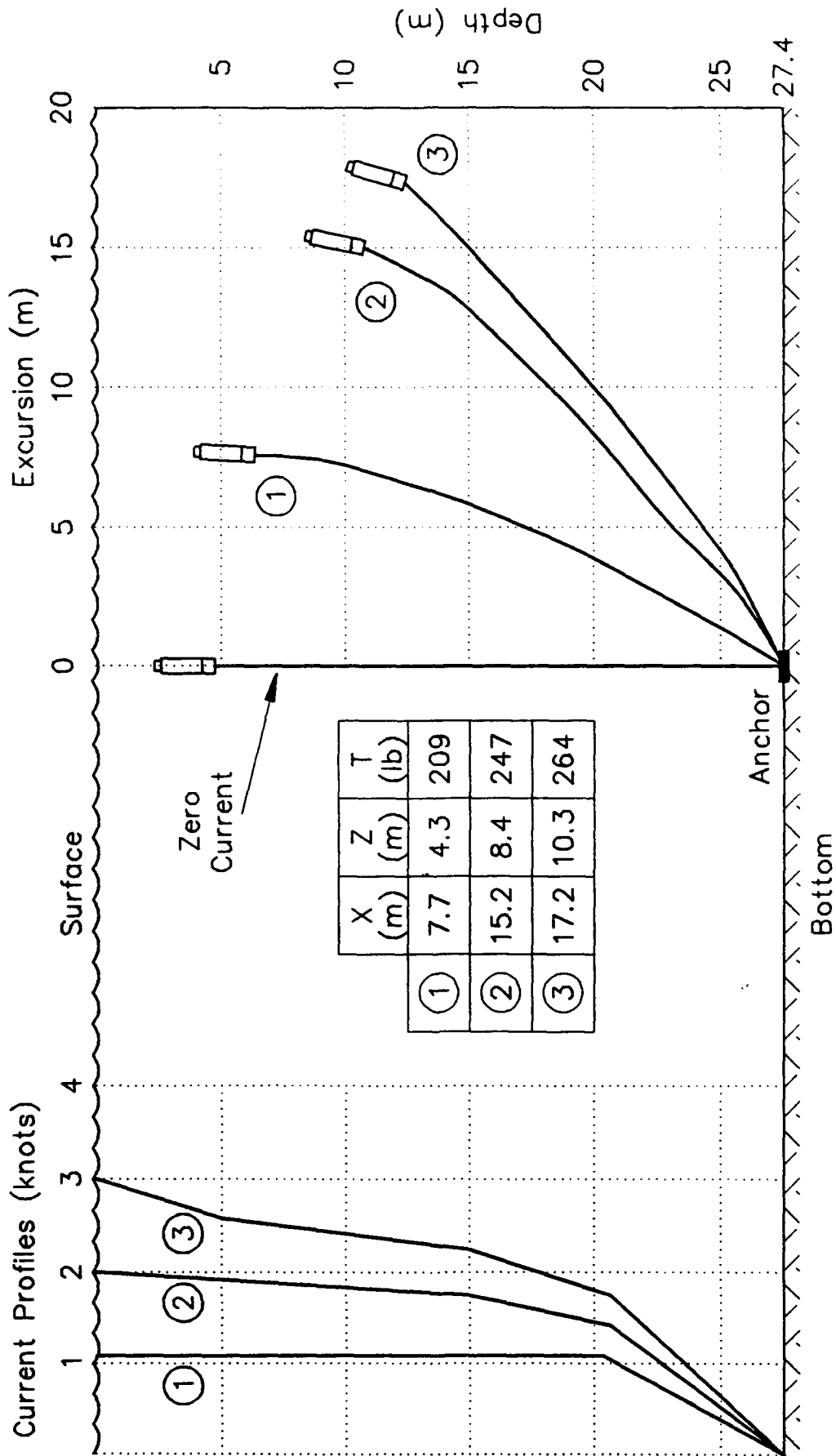

Fig. 4 CAPTOR Mooring, Statistic Analysis

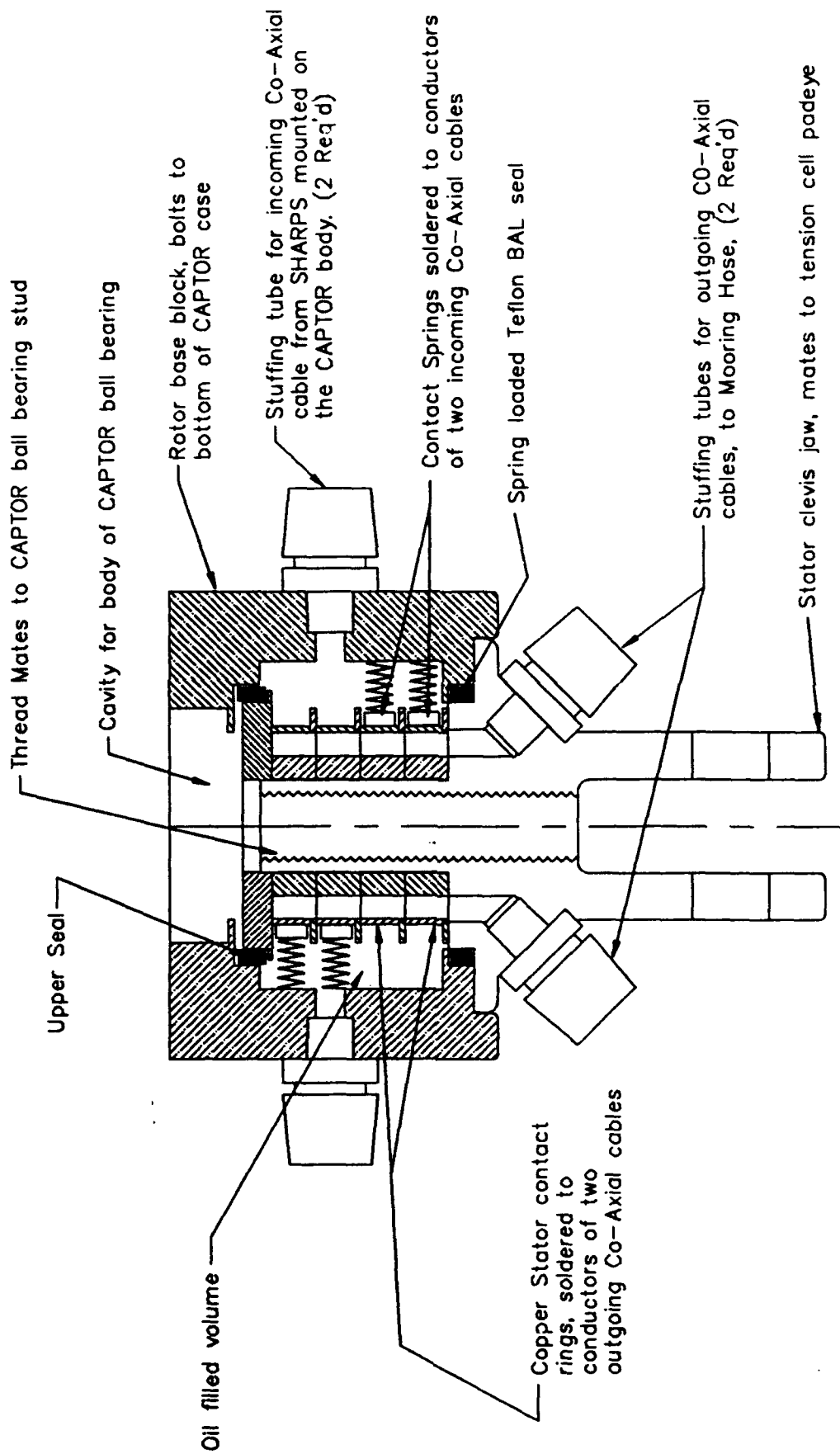

Fig. 5 Slip Ring Assembly

MOORING CABLE:

Oil Filled Hose: The mooring cable consisted of a Vectran^R fiber reinforced, oil filled, polyurethane hose. This hose provided the mechanical strength member between the CAPTOR body and its anchor, and housed the sensors to monitor the mooring dynamic response. These sensors included two tension cells, three axial accelerometer packages, and one SHARP transceiver. Tension was measured at both ends of the mooring cable. Accelerometer packages were mounted on electronic boards, potted in polyurethane and pulled in place with the help of a flexible, kevlar frame. The SHARPS transceiver was located approximately one-third of the mooring length down from the CAPTOR attachment point. It was first mounted inside the hose. Tests however, revealed poor acoustic energy propagation through the hose walls. The small transceiver head was subsequently mounted on the outside. The main components of the mooring cable are depicted in Fig. 7. The location of the sensors mounted in or on the hose is shown in Fig. 9.

Two 64.5 ft mooring lengths and two 5.0 ft sample lengths of the hose were acquired from the Aero and Naval Systems Division of the Martin Marietta Corporation, a manufacturer of high speed towed arrays of established reputation. The hose has a 1.14 in. OD and a 0.824 in. ID, the wall thickness being 0.1575 in. The hose is reinforced with 36 parallel cabled cords of Vectran^R, liquid crystal polymer fiber, each with a breaking strength of 550 pounds. Vectran^R is similar in strength to Kevlar but features better abrasion resistance and lower creep under load. The cords are spaced equidistant around the circumference and are embedded in the urethane hose wall. The nominal, ultimate breaking strength of the hose was 19,800 lbs (8,980 kg). The four lengths were terminated by Martin Marietta at both ends with titanium swaged fittings of proprietary design.

The four finished cable assemblies were subjected to a series of acceptance tests at Martin Marietta's facilities, Glen Burnie, MD. These tests were designed to assess the elastic response of the hose material, the holding power of the end fittings, the percentage of creep under high sustained loads, and the breaking strength.

Proof loading of the actual mooring line before deployment was performed at the same time. Appendix A contains a detailed description of the test specifications and of the test results.

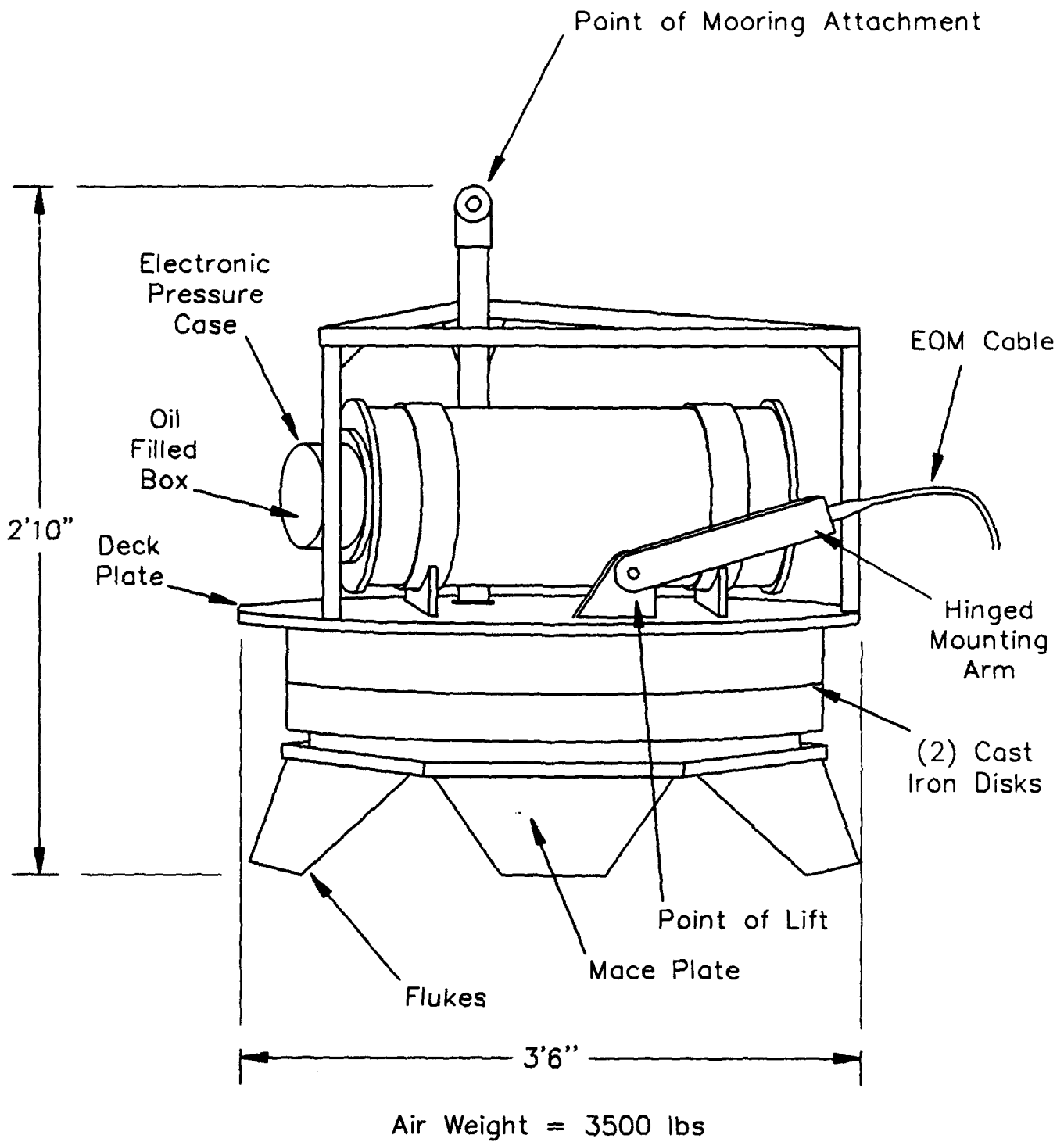

Fig. 6 Anchor Module

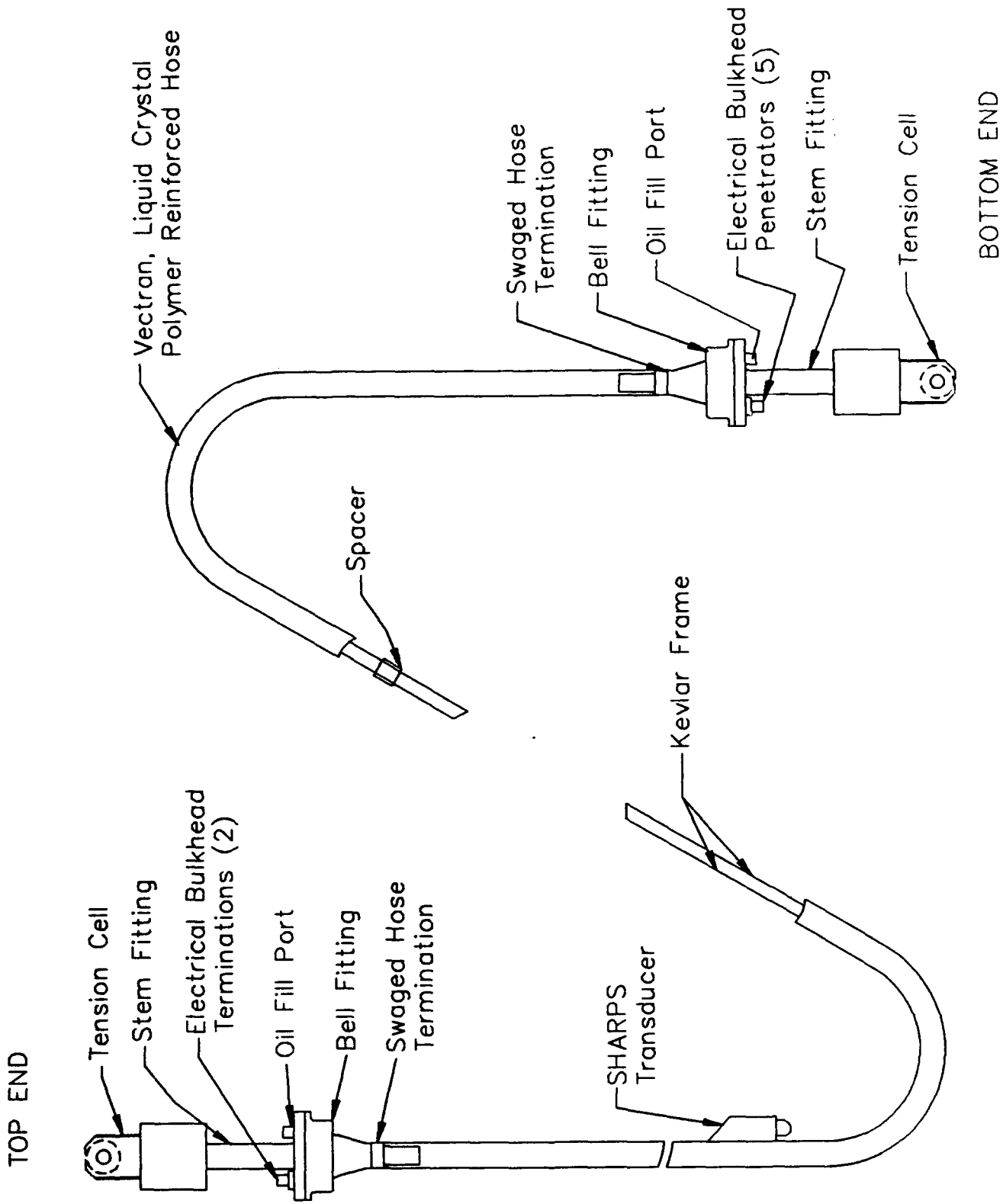

Fig. 7 Mooring Cable, General Assembly

Cable Connection Design: Provisions had to be made to insert the tension cells at both ends of the mooring cable, and to mechanically attach and electrically connect the hose to the CAPTOR body at its upper end and to the anchor module at its lower end. The resulting cable connection design, schematically depicted in Fig. 8, consisted of the following components:

- **Tension cells** - Two pressure compensated tension cells, with a 0 to 2000 lbs load range were procured from T-Hydronis (see data sheet in Appendix C). The tension cells have a pad eye on one end and a threaded hollow bolt at the other end to permit mechanical insertion. The electrical leads pass through the center of the bolt.
- **Stem fitting** - The stem fitting threads over the tension cell threaded bolt. Both are secured against rotation by a set screw. The fitting ends in a flange which supports the bulkhead connectors in number as required, and one oil fill port. An O-ring seals the stem against the tension cell cover.
- **Bell fitting** - Next a bell shaped housing bolts to and seals, with the help of an O-ring, against the flange. The narrow end of the housing is machined to permit the insertion of an O-ring, and eight 10-32 machine screws which 1) seals the bell and the hose off from seawater and 2) connect the entire cable end connection, and therefore the CAPTOR body or the anchor module, to the titanium fitting swaged at the end of the hose. The bell fitting provides a space for keeping all soldered electrical wires sheltered in an oil filled cavity.

Electrical Harness: The electrical harness (Fig. 9) was built and installed by attaching the three accelerometer modules to a flexible kevlar frame which could be pulled into the hose from one end. Each module consisted of two printed circuit boards, 5/8 in. wide by 6 in. long. Three twisted pairs of color coded wires were attached to the bottom end of the module. The module was potted in urethane to protect the boards and their components against mechanical abuse and the rigors of being assembled into the hose.

Two 1/16 in. diameter kevlar cords with a breaking strength of 300 pounds each were threaded through a number of Delrin spacer blocks. The spacer blocks were located at each end of the prescribed module location and held in place with epoxy and dacron stitching through the kevlar cord.

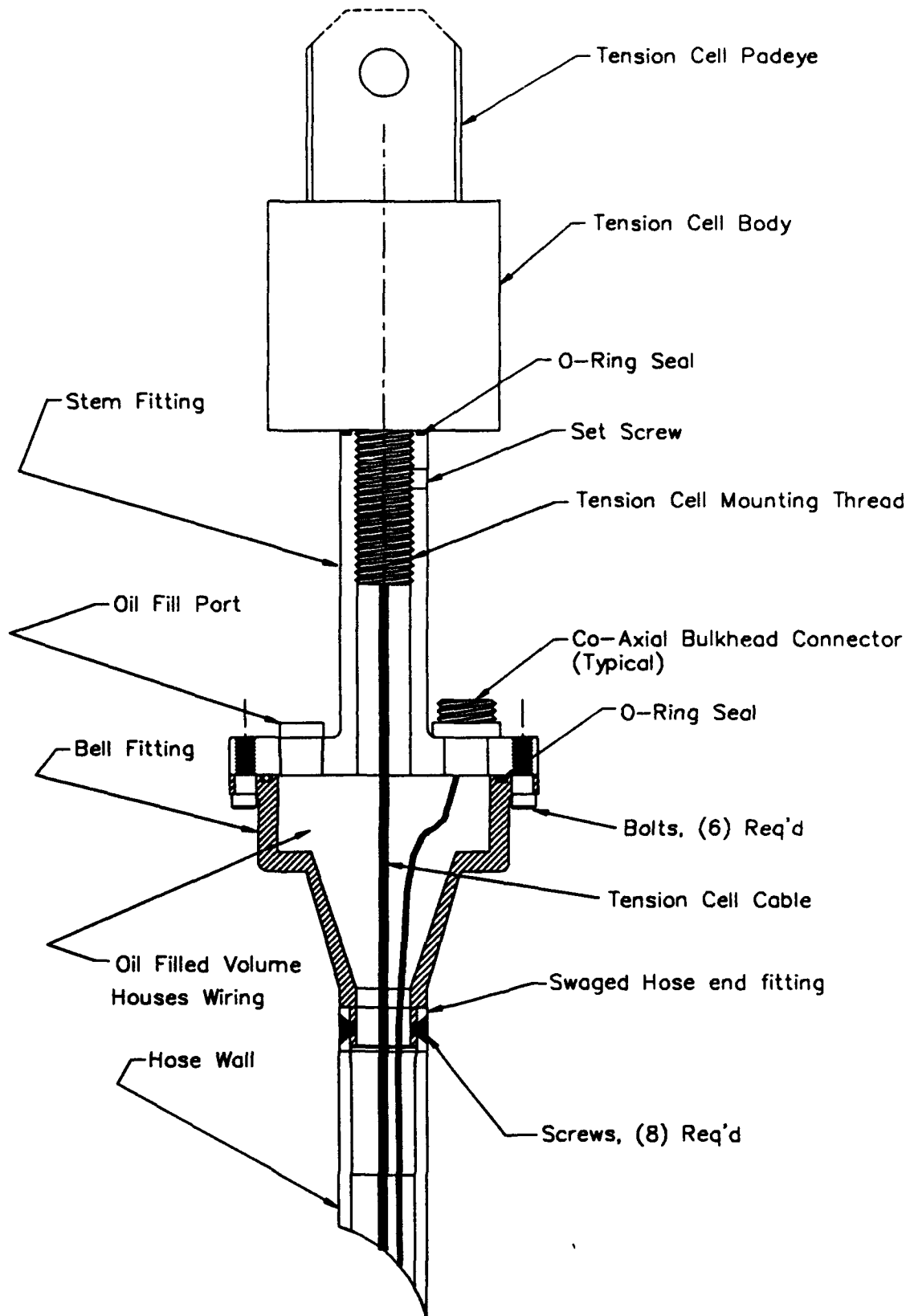

Fig. 8 Mooring Cable, Attachment

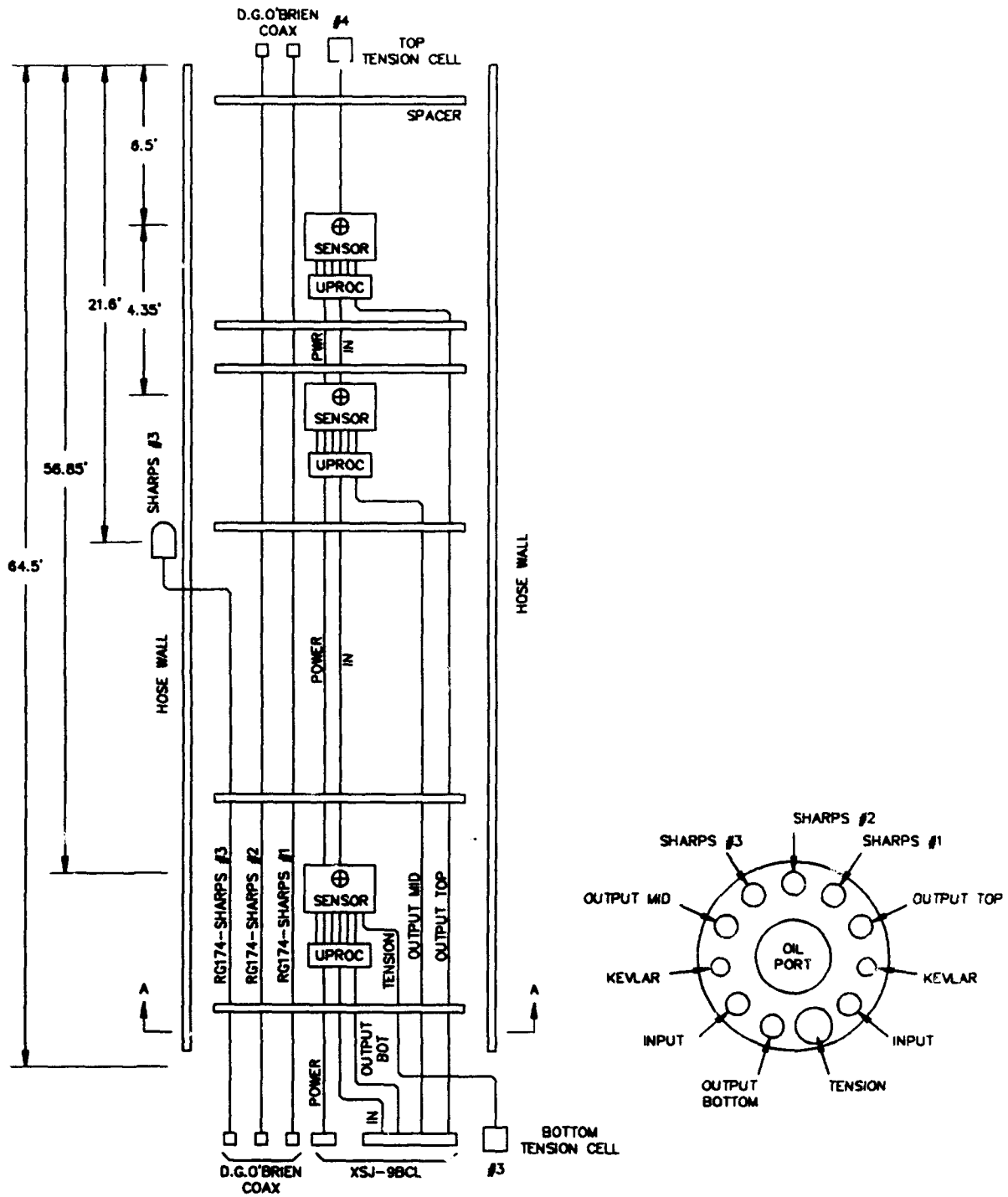

Fig. 9 Mooring Cable, Internal Layout

The three coaxial cables, (two at the vehicle, one midspan) were next threaded through holes that were predrilled in the spacer blocks. Each module was then attached in its appropriate place by stitching dacron thread through holes drilled in the printed circuit board and through the kevlar running lines.

The ends of the numerous electrical conductors were soldered to the inside of the bulkhead penetrators on the lower stem bulkhead along with the load cell leads. The completed wiring harness was pulled into the hose by the kevlar cords.

The next step was to attach the midspan SHARPS transceiver on the outside of the hose. To this end a 1.5 in. incision was made in one side of the hose wall, parallel to the axis of the hose. A blunt hook was used to fish out a loop of one of the three coaxial cables. The cable was cut in the loop and mated electrically to the back of the SHARPS transceiver head. Only the head was placed at this location, the electronics of the transceiver being housed inside the anchor module. The wall of the hose was abraded in the area of the incision and washed with an oil removing solvent. A rubber mold was clamped on to the side of the hose where the acoustic head protruded. The excess length of wire was pulled into the hose and the disconnected length above the joint was discarded. The mold was filled with CPC-19 urethane which provided a leak proof bond to the hose wall.

The electrical connections were made at the top bulkhead load cell mount fitting and the kevlar cords were attached to an eye on the inside of the fitting. This prevents the electrical harness from migrating down the hose due to the force of gravity. The top end of the hose termination assembly was then bolted together in its final form. The other end of the kevlar cords was fastened to a length of 3/16 in. bungee cord attached to an eye on the bottom fitting. The bungee allows the cable to flex without causing the kevlar cords to tighten and damage the electronics. The entire assembly was testing electrically and found to function in a satisfactory manner.

Two and a half liters of Isopar-L oil, provided by Martin Marietta was used to fill the hose. The hose was suspended with one end 10 ft higher than the other and the oil was

pumped on from the bottom end until it came out through the vent in the top termination. The hose wall compressibility was sufficient to negate the need for any external pressure compensation reservoir.

BOTTOM EOM CABLE: Figure 10 shows a cross section of the bottom mounted electro-optical-mechanical "EOM" cable. 850 meters of this cable were used to connect the anchor module to the moored R/V ASTERIAS.

The cable has three 125 micron single mode optical fibers, two of which are used to transmit data from the anchor module to the shipboard lab and instructions from the lab to the anchor. There are also three color coded #11 AWG copper electrical conductors in the cable core which were used to supply 110 volts AC to the power supplies and electronics system in the anchor module. The cable core is covered with two contrahelical layers of steel armor wires. The cable strength member wires are potted into a tapered cone fitting at each end with a 15 ft length of the core protruding. The mechanical attachment to the anchor end is designed to swivel both horizontally and vertically so as not to bend the cable around the anchor. A rubber bending strain relief boot softens the transition between the cable and the potted fitting.

The core at the anchor end goes through a stuffing tube into the oil filled box where it mates with bulkhead connectors. The cable core on the shipboard end is carried into the lab and attached directly to the electronics on the bench.

MECHANICAL DRAWINGS AND DOCUMENTATION: Documentation for the CAPTORDYN experiment mechanical design can be found in Appendix A, "Mechanical Design Documentation."

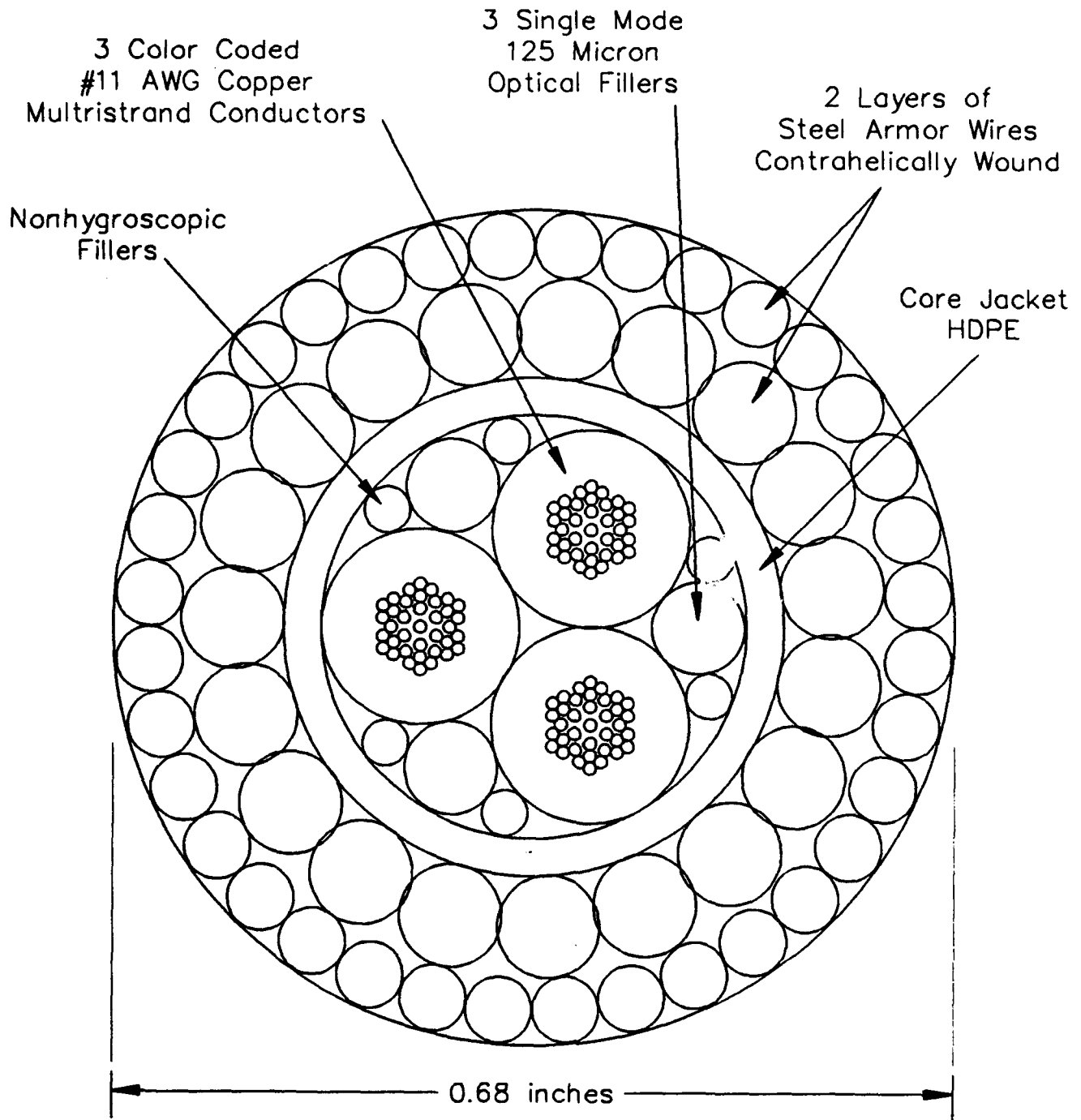

45000 lbs Rated Breaking Strength
 Air Weight = 0.73 lbs/ft
 Water Weight = 0.33 lbs/ft

Fig. 10 Bottom EOM Cable

ELECTRICAL DESIGN

GENERAL CONFIGURATION: The CAPTORDYN data collection system consisted of a number of in situ sensor packages which measured different physical parameters, digitized the measurements and sent the data to the surface for recording in near real time. These sensors monitored the response of the CAPTOR body and its tether to strong and variable currents. The currents were also concurrently measured and recorded.

Data obtained in situ were telemetered to the small research vessel R/V ASTERIAS moored in shallow and sheltered waters 800 meters away from the deep, turbulent site. This scheme provided ease of anchoring and minimized the risk of tangling with the mooring components. It also avoided the possibility of data contamination produced by ship noise.

To accommodate the large volume, high frequency of data and power, an EOM cable connected the ship to the telemetry. The ship acted as a comfortable field lab, providing the prime power to the at-sea instrumentation and the display and recording instrumentation.

The basic interface consisted of an optical receiver and transmitter at each end of the optic fibers which transformed the electrical signals to light using a 1300 nm laser. The laser transmitter was driven by the output of a ten-channel digital multiplexer which sampled each incoming serial data stream at a 10 MHz rate. The multiplexer used was the TAXI chipset providing a 100 MHz bit rate. At the receiving end, the optical signals were transformed back to logic signal levels and ten channels of serial data were synchronously demultiplexed.

To facilitate bidirectional operation, two fibers were used, one for upcoming signals and one for down. This was deemed more easily accomplished than multiplexing the up and down signals on the same fiber using two frequencies or colors of light.

Figure 11 is a block diagram of the electrical system. Its components include:

- The CAPTOR body with SHARPS transceiver "D" mounted at the end of the stabilizer arm.
- The oil filled tether with, from top to bottom, the SHARPS transceiver "E", the upper tension cell, the top triaxial accelerometer package, the middle accelerometer package, the SHARPS transceiver "F", the bottom accelerometer package, and finally the lower tension cell.
- The sea floor mounted equipment made of the acoustic doppler current profiler (ADCP) and three SHARPS transceivers ("A", "B", "C"), located at the corners of an approximately equilateral triangle. These transceivers formed a triangulation net from which the positions of the target transceivers ("D", "E", "F") could be determined by acoustic ranging.
- The anchor module, which housed the power supplies and the electronics for the interface between the electrical signals generated by the sensors and the fiber optic cables
- The fiber optic EOM cable
- The surface electronics consisting of the optical interface, the SHARPS interface, the display and logging instrumentation

CAPTOR AND TETHER POSITIONS MONITORING SYTEM: The heart of the large scale position monitoring system is the Sonic High Accuracy Ranging and Positioning System (SHARPS). This system was designed for precise tracking of targets at high update rates in high multipath environments. For ranges up to 100 m positioning accuracy is within ± 2 cm with repeatability of 0.5 cm and sampling rates to better than 10 Hz.

The basic system typically consists of three bottom or surface mounted acoustic transceivers in a roughly triangular pattern. Three transceivers in a straight line, will not work. In our application we chose to use a bottom mounted network with transceivers spread out on the sea floor at the end of 100 ft radials spaced about 120 degrees apart. The target transceiver, whose x, y & z positions in the water column are desired lies somewhere above the three transceiver net but not necessarily within the vertical perimeter of the net.

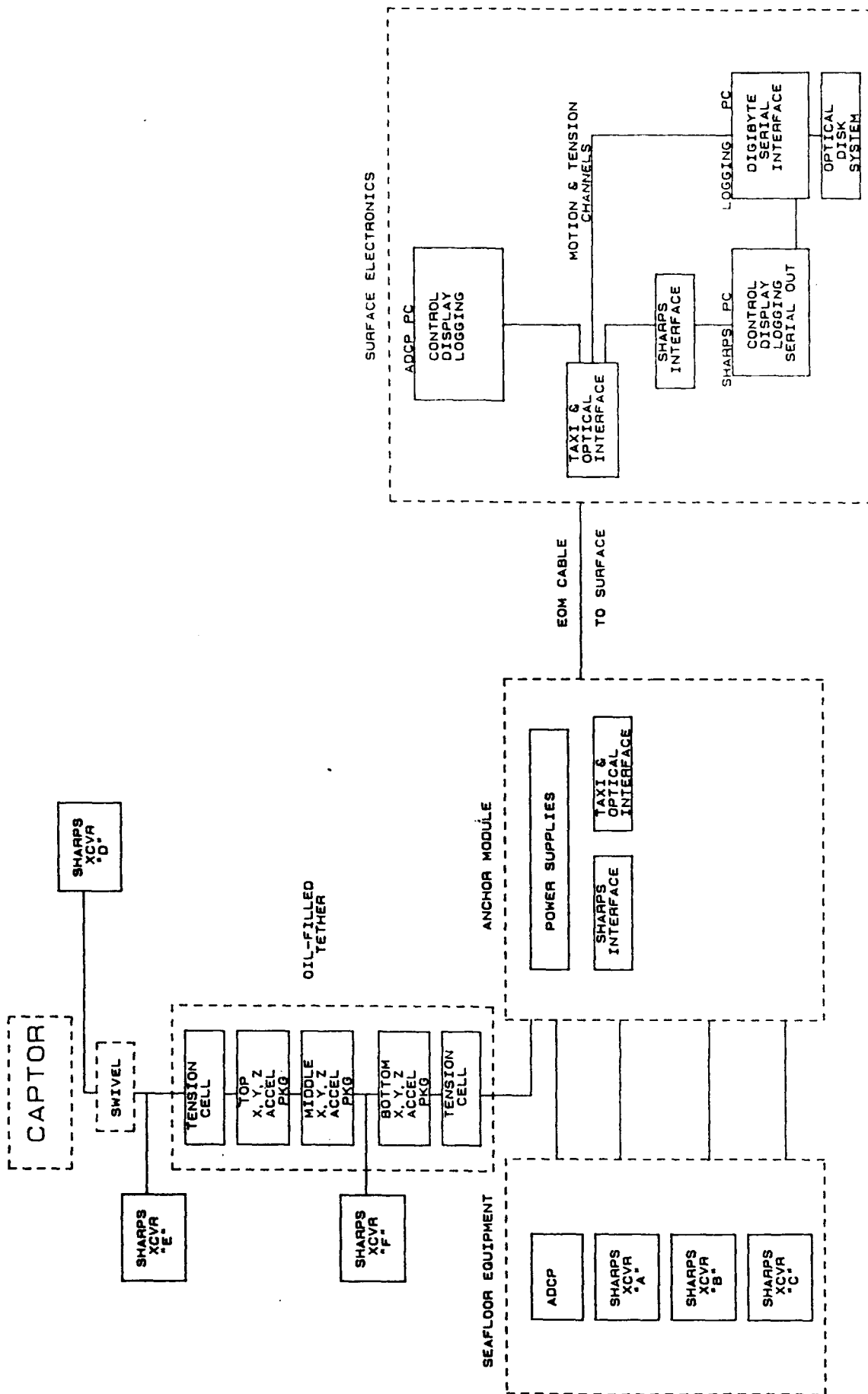

Fig. 11 CAPTORDYN Electrical Block Diagram

Short bursts of 300 kHz acoustic energy are sent from the target transceiver and received by three net units. By comparing the arrival times of the burst at the three locations and knowing the speed of sound in seawater and the exact locations of the three bottom units, the position of the target can be calculated by triangulation. In our implementation, we had three targets transmitting, one at a time in rotation, so that the effective update rate of each target was 3.3. Hz.

The standard SHARPS hardware consists of small cylindrical transceivers connected by underwater grade coaxial cables via a junction box directly to the transmitter/receiver card plugged into the backplane of a PC. In this experiment, the transmitter/receiver was 800 meters away from the transceivers and coaxial cables could not be used effectively. This meant all the SHARPS signals would have to be carried on the fiber optic bundle. The SHARPS signals on the coax are typically a 30 V transmit pulse and a 10 V receive signal superimposed on the 30 V level. Since the fiber carried only logic level signals, the transmit and receive signals had to be transformed into logic level signals for TAXI, sent thru the fiber, and then reconstructed at the other end. Once converted to logic levels the signals were further transformed using differential RS485 line drivers to interface to the TAXI system. No timing degradation takes place in the SHARPS signals thru use of the TAXI due to the extremely high sampling and thrupt rate.

TENSION MONITORING SYSTEM: The instantaneous tension in the tether line was simultaneously measured at both ends of the tether. Data thus obtained could be used to determine the drag and the turbulence induced by currents on the CAPTOR body and its tether line.

Two identical T-Hydronics tension cells (Appendix C) were screwed into the fittings at each end of the mooring hose with the electrical connections channeled inside the threaded stud of the cell which isolated the wires from the outside seawater and made expensive and vulnerable underwater connectors unnecessary.

The tension cells had a 2000 lb capacity and a 100 psig seawater depth rating. They had a sensitivity of 2.0 mV/V full scale and an overload rating of 3000 lbs. A local 8 V regulator supplied the bridge and the signals were amplified for a 0 to +4 V full scale signal range. The output of the amplifier was sampled at a 50 Hz rate and digitized to 12 bits.

The tension cells were first calibrated in the WHOI universal tensile machine. Then they were tested at the end

of the WHOI dock in 65 ft of water for changes in calibration, offset, and electrical leakage to the housing.

STRUMMING MEASUREMENTS: Measurements of mooring cable strumming were considered highly desirable. To accurately duplicate the strumming response of an homogeneous mooring line of constant diameter, the CAPTOR tether had to be of constant cross section, with no bulges nor mass discontinuities. Inserting small, light, triaxial accelerometer packages at well selected intervals in an oil filled, fiber reinforced, flexible hose appeared to be a workable, elegant solution.

It was determined that strumming rates would not exceed 10-15 Hz and, if sampled at a 50 Hz, this rate would provide sufficient frequency to prevent aliasing. Because of the concern that there might be some unexpected higher frequency components from some other forcing mechanisms, it was decided to sample as fast as possible and in addition add low pass filters to eliminate any residual high frequency components that could alias down into the frequencies of interest.

Another important consideration in establishing the sampling frequency was the data transfer rate that could be used. An upper limit of 19.2 k baud was established for both the immediate transmission media and the processing capabilities of the multi-channel serial processor available. The data to be sent consisted of five parameters (x, y, and z accelerations, tension, and temperature) of 12 bit resolution, requiring two bytes per parameter. Coding was performed to uniquely identify the particular parameter in the data stream and make the least significant byte and the most significant byte distinguishable. With this as the limit, sending five two-byte values converted to ten ASCII characters of ten bits (1 stop bit, 8 data bits, 1 stop bit) allows a sampling rate of once every 100 bits sent or 192 Hz. Due to operational overhead in the processor (like having to recognize an incoming sample command versus a mode change command) the actual achieved sampling rate was only 140 Hz.

Each accelerometer package (Appendix C) consisted of three orthogonally mounted accelerometer chips, amplifiers to scale their outputs, a five channel, 12 bit A/D converter with serial output, a microprocessor to orchestrate the whole measurement process, and a UART to send the serial data from each package to the anchor electronics and on up the fiber optic cable to be recorded at the surface. Also included and measured were temperature sensors to allow post correction of accelerometer temperature drifts if those drifts proved to be excessive. In addition there were scaling amplifiers for the tension cell outputs in the packages at the top and bottom of the tether. The middle package measured supply voltage in

place of what would have normally been the tension measurement.

Each accelerometer package was tested and calibrated on a vibration table before assembly into the tether hose. Each +/- 5 g unit was checked for on axis as well as cross axis performance. This calibration data may be found in the Appendix B.

As previously described, the packages were suspended on a cable fixture in the center of the hose cross-section and their outputs connected by coaxial cable to the anchor. Raw DC power of 8 V was supplied to each package and local regulators supplied isolate power to each of the modules. A common sample command line was connected to each package and conversions on all packages occurred simultaneously for like parameters.

CURRENT MEASUREMENTS: Currents at the site were measured in two ways. First, a string of three S4 electromagnetic current meters were hung in the current profile at prescribed depths to establish a rough profile, one being placed at the level of the CAPTOR body to better establish the currents acting upon it. These made one minute averages of half second samples (120 data points) once every three minutes for the duration of the experiment.

Secondly, a rented ADCP was placed in the flow channel and established 20 flow strata levels or "bins". The four obliquely upward looking acoustic beams measured the water movement in three dimensions and produced a current vector at each of the 20 levels referenced to magnetic North. These measurements were made at a one Hertz rate and one minute averages were calculated. These averages were sent via an RS485 serial communication link at 9600 baud to the anchor electronics for transmission to the surface. The ADCP produced, in addition to the current vectors, an enormous amount of support data on such things as time, signal strength (a function of AGC level), percentage of samples that were good, and other operational data to help determine the validity of the measurements. A list of those parameters and the setup information on the ADCP can be found in Appendix C.

This data from the ADCP was originally to be recorded directly on the optical disk along with the accelerometer data in synchronism. Due to problems with the second serial port on the ADCP PC we could not record the data directly but this was of no consequence since the data is time stamped and is a one minute average which makes synchronous recording unnecessary.

ANCHOR ELECTRONICS: The electronics housed in the pressure case on the anchor provided power to the various circuits, interfaced the incoming data streams to the fiber optic cable, performed the level translations for the SHARPS signals, and in general served as a junction box for the many cables. The following table lists the seven power supplies housed in the anchor module.

MAKE	MODEL	OUTPUT	USED BY
PowerOne	HCC24-2.4-A	±24 VDC @ 2.4a	ADCP
PowerOne	HC12-3.4-A	+12 VDC @ 3.4a	ADCP
PowerOne	HB28-1-A	+28 VDC	SHARPS
PowerOne	HB5-3/OVP	+5 VDC @ 3.0a	Interface logic
PowerMate	EMR-18/20C	+18 VDC @ 2.5a	Accelerometers *
PowerMate	EMR-9/10B	+9 VDC @ 1.8a	Optic Transmitter and receiver
PowerMate	EMR-9/10b	-9 VDC @ 1.8a	Optic Transmitter and receiver

* Raw power supply for an 8 VDC local regulator to power accelerometer modules and tension cells.

Six bidirectional channels of SHARPS level changing and pulse shaping circuits were built in the anchor. Two of the SHARPS units (the ones on the tether) had all their electronics located inside the pressure case with only the transducer itself located remotely. Monostable multivibrators controlled the generation of the short burst of acoustics while still others of longer duration (50 ms) and operating in the non-retriggerable mode prevented bursting at rates faster than 20 Hz. On a previous deployment (DYNAMOOR), multiple bursts, initiated by noise in the communication path, caused excessive heating and failures in the transmitter circuits due to the high duty cycle. The 50 ms lockout period eliminated this problem and did not slow SHARPS update rates as reverberation from seafloor and surface where the limiting factors. Although only the three seafloor SHARPS needed to have the bidirectional communication capability (the targets on the CAPTOR body and the tether only transmit), hardware for all six channels was made so as to allow for troubleshooting and checking of all acoustic paths in both directions.

In order not to modify the standard TAXI boards, RS485 drivers and receivers were added to the SHARPS interface where it communicated with TAXI.

SHIPBOARD ELECTRONICS: The topside equipment consists of 2 dedicated PC systems, an optical interface, a SHARPS interface, and a third PC used to mass store all the data on 1 gigabyte optical disks. This PC, a 25 MHz 386 with coprocessor, processes up to eight channels of serial data using a Digiboard 8 channel controller/buffer to sequence the acquisition and writing to optical disk of the multichannel output of the topside TAXI demultiplexer. The TAXI splits the uplink signals from the fiber out to the appropriate PC for processing.

The SHARPS system again has its own additional interface to recreate the appropriate signal levels for processing by the SHARPS card in the SHARPS control PC. This PC controls the operational parameters of the system, initiates transmissions, displays target and net position data on the screen, and logs position data to the hard disk. The same x, y, z position data is also sent out the serial port to be logged on the optical disk.

The ADCP PC processes its data, displays the current profiles, and logs these profiles (along with other operational and status information) to its hard disk.

The data stream coming from the accelerometers is processed by the logging computer. The data is decoded, the parameter identifiers stripped off, and the data stored on optical disk in blocks on the tape along with the SHARPS data in near real time. Each block on the disk has a header including a block number, a time stamp reference, and the data. The optical disk system used was a Panasonic Model LF-7010 with Corel SCSI card and Corel software driver kit #CIK-UNI-IBM storing up to 500 megabytes per side on Panasonic LM-D702w read/write optical disks.

ELECTRICAL SCHEMATICS AND DOCUMENTATION: Hardware and software documentation for the CAPTORDYN experiment electrical system can be found in Appendix B, "Electrical Design Documentation."

EXPERIMENTAL RESULTS

The following describes the difficulties or system deficiencies encountered while performing the experiment. A summary follows of the results obtained despite this set back. Finally a list is given of the hardware and software deliverables to be provided to NSWC under the terms of the contract.

EXPERIMENTAL DIFFICULTIES:

Sharps: Shortly after deployment, when the SHARPS system was brought on line, it was discovered that the SHARPS "D" transceiver, located on the end of the CAPTOR's stabilizer arm, was not functioning. It would neither transmit nor receive. (In normal operation, "D" would not receive but only transmit. However, in the "RANGE" test mode it is tested for both functions). "D" had been working throughout the dock test along with the three transceivers "E" and "F". Further testing and diver inspection of the unit, its cables, and connections revealed no more clues as to the cause of the malfunction. After finding no problem, a number of replacement scenarios were considered but none found viable short of recovery of the whole system. Since recovery was not possible in the time available, it was decided to go without the "D" position data.

Upon recovery and post cruise inspection, no shorts or opens were found in the coaxial cables or connections inside the tether. Likewise no problems were discovered in the slip ring assembly located between the tether end and the CAPTOR body and through which the signals to and from "D" flowed. This swivel was checked both statically and dynamically with no loss of signal noted.

During examination and testing of the SHARPS interface circuitry in the anchor module, a shorted inductor in the input to the receive circuit on channel "D" was discovered. This shorted inductor would prevent reception of signals on channel "D" (which was not its normal mode of operation for this experiment) but would not prevent transmission from "D". This inductor failure has not been explained although, as previously stated, a similar occurrence happened on the previous DYNAMOOR deployment but was associated with a noise problem which destroyed the complete output stage including the inductor. For the CAPTOR DYN experiment a lockout feature

was added to the driver circuit to prevent such noise related failures. This leaves no explanation as to the cause of the malfunction of the SHARPS transceiver "D".

SHARPS transceivers "E" and "F", located at the top of the tether and one third the way down respectively, were not received continuously but appeared to randomly "fade out" usually with only one being received at a time. It is thought that shadowing due to rotation and effects of the strong flow shear in the water layer next to the tether could cause such conditions.

The problems encountered with the SHARPS system were not with the hardware and software as supplied by Marquest, but rather stemmed from our modifications and additions to the system hardware.

Accelerometers: The accelerometer package at the bottom of the tether was not working when the system was powered up. The top and middle packages seemed ok but the middle started to become intermittent shortly afterwards. The top package provided continuous data until the early morning of the third day when all data stopped. Power was cycled off and on a number of times to try and restart the microprocessors in the accelerometer packages but to no avail.

Upon recovery of the tether it was discovered that the cable connection to the tether from the anchor module had been partially torn away from the tether due to a connector mechanical failure. The connector shell had been broken, probably stressed by the cables vibration in the strong current, and allowed salt water to flood the connection area shorting out the signals and power. Later examination of the other cable and connector showed a fracture of that connector too but no water had yet penetrated the connections. The manufacturer of the connectors had no reports of problems with this particular connector type. More rugged connectors should be used in the future.

Discovery of the broken connectors explained the failure of the top accelerometer channel on the last day but does not explain the intermittency of the middle channel or complete loss of the bottom channel as partial flooding of only one or two channels in the same connector seems highly unlikely. The tether hose was later tested electrically and only the top package would respond. Removal of the end fitting revealed no broken connections, shorts, or entrapped water. The whole tether assembly was somewhat vulnerable to excessive physical abuse which could cause such failures but it was thought to have been kept fairly well protected. As with the SHARPS above, all accelerometer packages had responded correctly at the dock test.

ACCOMPLISHMENTS: Despite the set backs just reviewed, the CAPTORDYN experiment has been very productive. A summary of the technical accomplishment and of the data acquired during the three days on station include:

- Real time observation of the dynamic response of a cylindrical buoy immersed in very strong currents, from a remotely located control and recording station.
- Operation of a SHARPS network, over a long, bidirectional fiber optic link.
- Synchronous logging of four channels of 19.2 k band serial data plus other slower speed data to an optical disk with time stamps and header information.
- Acquisition of time series of XYZ position data at the top and one third down from the mooring cable, taken at 5 Hz rate.
- Acquisition of time series of XYZ accelerations at the top and at 11 ft down from the top end of the mooring cable at 50 Hz.
- Acquisition of time series of mooring line tension, both at the CAPTOR and the anchor module ends, at 50 Hz.
- Time series of one minute averages of ADCP three dimensional current vectors taken in 20 layers through the water column.
- Finally, time series of current measurements at three discrete depths obtained with the help of moored InterOcean S4 Current Meters.

CONCLUSION

The development, calibration and intensive testing of a SHARPS transceivers network with six nodes, the fabrication and testing of a fully instrumented reinforced hose equipped with tension cells and three triaxial accelerometer packages, their integration in a complex optical telemetry system, and finally their deployment in deep, high current location constitute remarkable engineering and operational achievements.

The hardware deficiencies experienced certainly casts a shadow on the successful completion of the experimental objectives. With one SHARPS missing the 3-D rotation of the CAPTOR body cannot be assessed. Furthermore the acceleration time series at the hose bottom end is missing entirely.

In the risky business of experimental oceanography, no system is fit for sea until its performance in situ has been demonstrated, at least once. In the case at hand, all components and the whole system had been tested on the bench and in the Woods Hole harbor waters. When installed at the site the high currents proved to be more destructive than expected. Time and money should have been set aside to allow for eventual retrieval, repairs and resetting. Unfortunately, these contingencies were not available.

Despite the difficulties encountered, a large set of data was acquired and recorded. The analysis of these data, to be performed by NSWC engineers, should yield unique, very interesting results.

The DYNAMOOR and CAPTORDYN experiments have pioneered a technique for taking, transmitting, and recording at a remote station, synchronous, high frequency measurements of the forcing environment and of the dynamic response of moored structures. With some refinements and obviously some components upgrading, the experimental set up described in this report can be used again, as an excellent tool, to foster research in the field of marine structural dynamics.

REFERENCES

[1] Berteaux, Henri O., A. Bocconcelli, C. Eck, S. Kery, P. Wansek, "The DYNAMOOR Experiment," Proceedings of the MTS 1992 conference, Washington, DC, WHOI Contribution #8129.

[2] O'Neill, J.J., J. Berezow, J. E. Goeller, "Means of Controlling the Dynamic Motion of Bottom Moored Mine Cases Exposed to High Current."

[3] Berteaux, Henri O., Program SSMOOR," 1988, Distributed by CDMS, Inc., PO Box 182, Woods Hole, MA 02543.

APPENDIX A: Mechanical Design Documentation

SLIP RING ASSEMBLY

TECHNICAL MEMORANDUM

Four Conductor Slip Ring for Mooring Applications

Seam M. Kery

Woods Hole Oceanographic Institution

August 3, 1992

Abstract:

The Captor experiment of the ONR Moored Array Technology Proposal required a four conductor slip ring. The Captor program measures the motion of a cylindrical subsurface buoy and cable moored in strong currents. The buoy features a trailing fin which stabilizes the buoy and causes it to align itself with the flow. Two Sonic High Accuracy Ranging and Positioning (SHARPS) transducers needed to be mounted to the buoy. The current changes direction at the mooring site every 6 hours. A slip ring was developed to bring the two SHARPS coaxial cables around the rotary joint located at the bottom of the buoy.

Introduction:

The buoy came equipped with a ball bearing swivel on the bottom from which a 3/4" - 10 bolt protruded. The device consisted of a delrin plastic block which mounts to the bottom of the buoy such that it did not rotate. A steel clevis fitting with an internal 3/4" - 10 thread bears the mooring load from the swivel to the mooring line. Four copper clad delrin disks and two Teflon BAL seals thread onto the shaft of the clevis fitting. Three seal screws and an O-Ring hold the disks onto the shaft so that they can not move relative to it. Two Woodhead stuffing tube fittings were also machined into the exposed part of the clevis and the co-axial cables were led down through these and soldered to the four disks. These two co-axial cables rotate relative to the buoy with the clevis fitting.

There are 8 posts in the base block, which each hold two Beryllium-Copper leaf springs in a staggered pattern of layers - 1, 3 and 2, 4 on alternate posts. Two additional Woodhead stuffing tubes allow the two co-axial cables that stay with the buoy, to be wired to the springs. Each of the 4 layers has 4 of the springs wired together to one of the corresponding four channels on the disks. Four springs per layer insures that at least one will be in electrical contact with the corresponding disk at all times. The disks have a wide rim on one end which prevents the brushes from the next layers from accidentally shorting across.

The entire cavity between the base block and the clevis fitting was filled with light mineral oil to prevent seawater from reaching the exposed electrical conductors.

The slip ring performed as planned for the life of the experiment. Performance can not be assessed with any reasonable accuracy because one channel was never hooked up to anything and

the other failed part way through the test at another component. The assembly showed good electrical properties and mechanical integrity after completion of all testing.

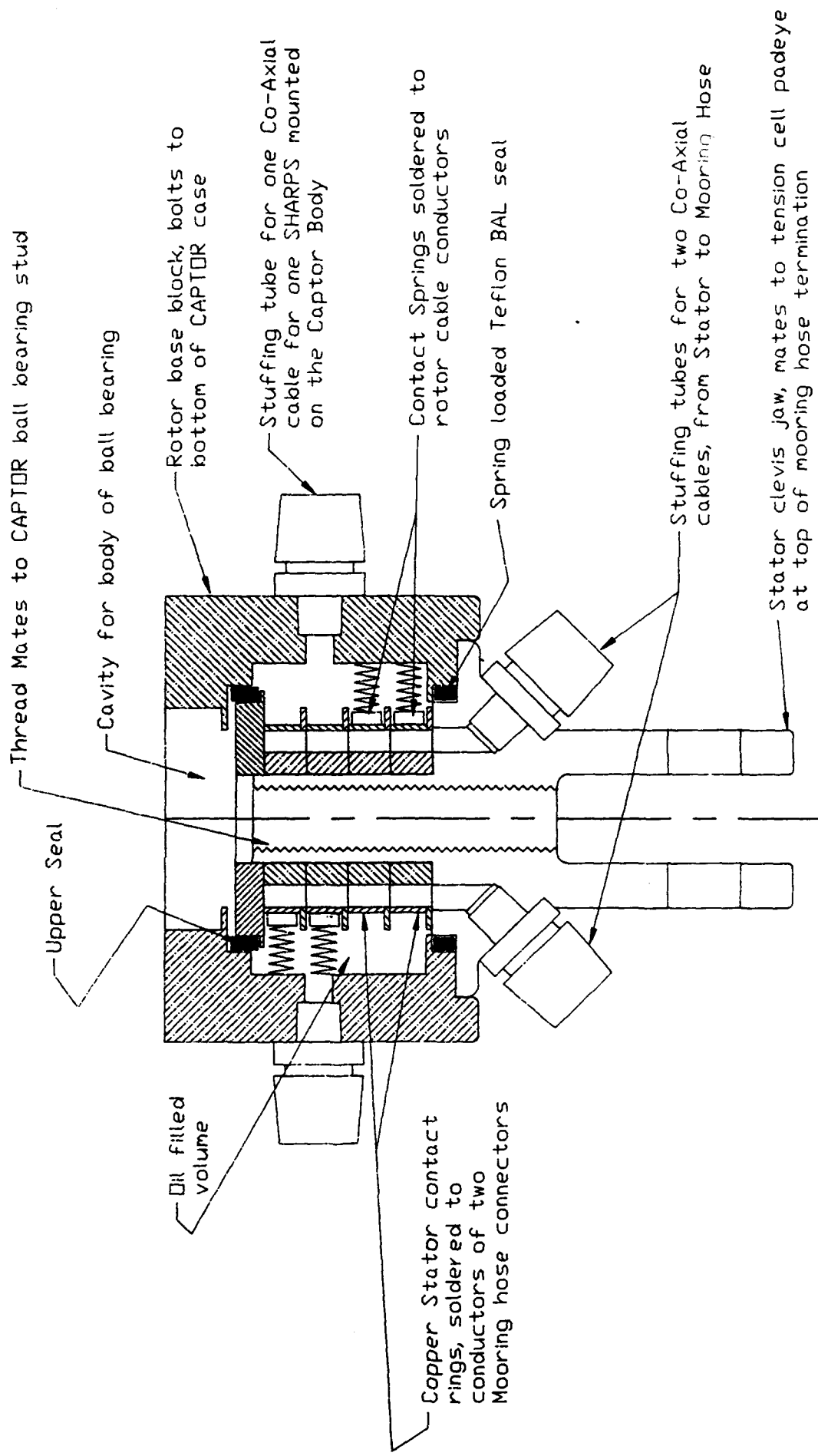

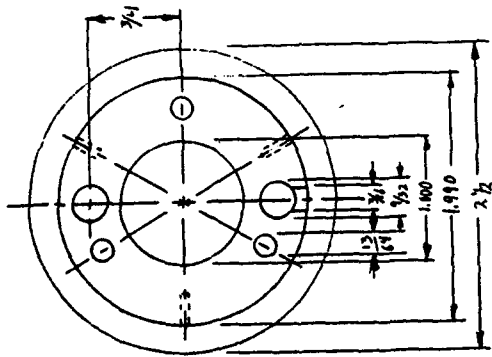

USE 2-56 BRASS SCREWS TO ATTACH
COPPER RING TO DELRIN CORE THEN
SPIN POLISH THE COPPER, CLEAN, SMOOTH
AND SHINY.

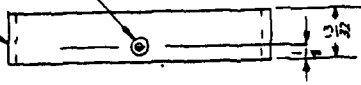

DRILL THRU #42 + COUNTERSINK
100° FOR FLAT HEAD SCREWS

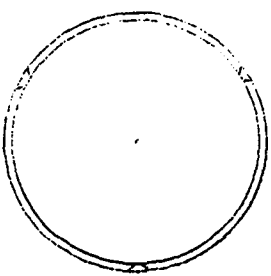

DRILL + TAP 2-56, (5) PLACES AS SHOWN 1/4" DEEP

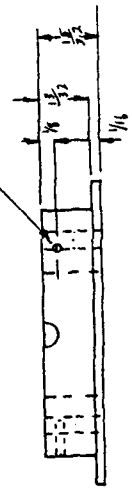

5 REED

Woods Hole Oceanographic Institution Ocean Systems & Moorings Lab Ocean Engineering Dept.		CONTACT DISKS FOR CAPTOR SLIPRING ASSEMBLY	
DATE APRIL 7, 1972	DRAFT S. KERY	PROJ. NO. 100 192.00	APPVD FULL
Tolerances Fractions $\pm \frac{1}{4}$	Decimals .005	Material COPPER + DELRIN	SCALE FULL
DWG. No. B 423		REV. A	Sheet 1 of 6

DRILL $\frac{7}{16}$ " BY $\frac{1}{16}$ " DEEP AT 45° FACE $\frac{1}{16}$ "
TAP $\frac{1}{4}$ "-NPT 2 PLACES AS SHOWN

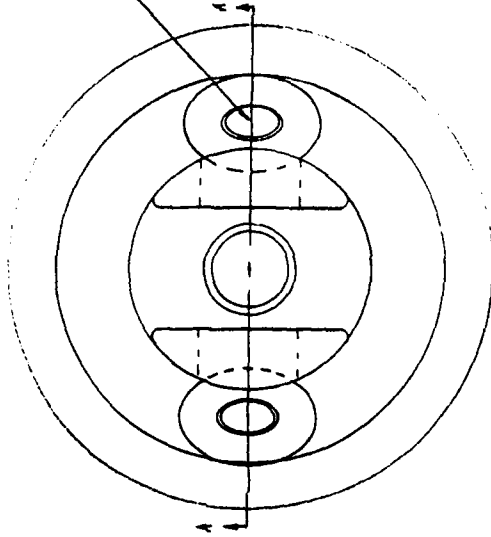

DRILL #25 TAP 10-32 BY $\frac{1}{2}$ " DEEP (3) PLACES
ON A 1.5" DIA B.C.

DRILL $\frac{3}{8}$ " TO INTERSECT $\frac{1}{4}$ "-NPT HOLE (2)
PLACES ON A 1.5" DIA B.C.

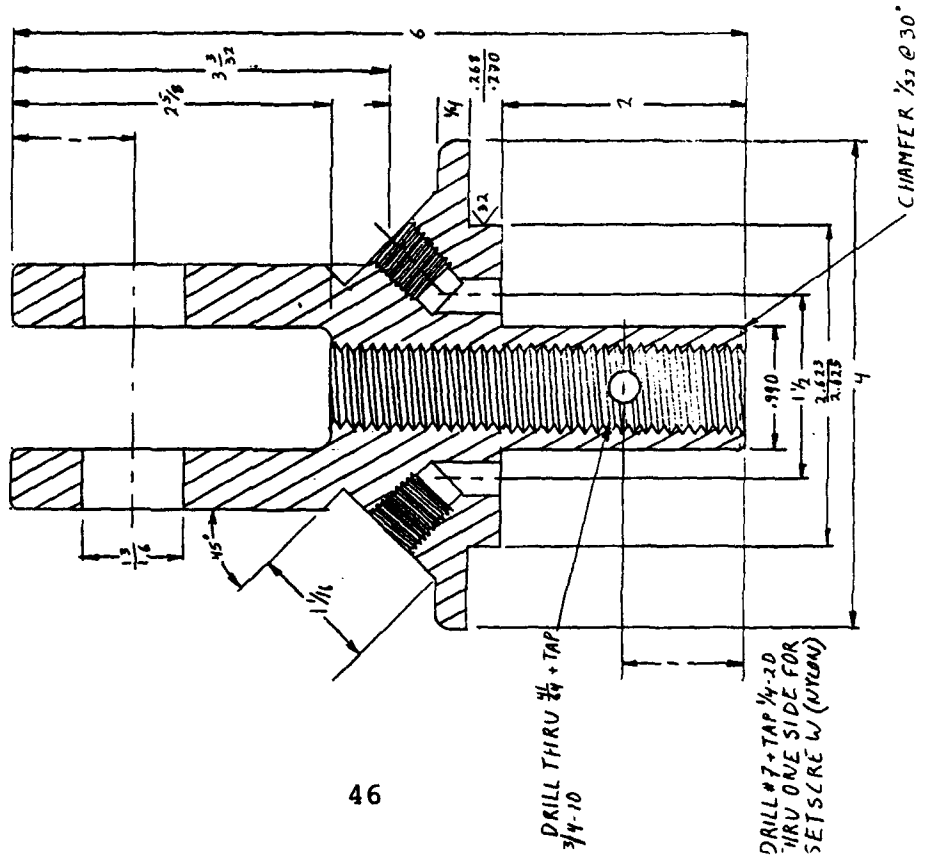
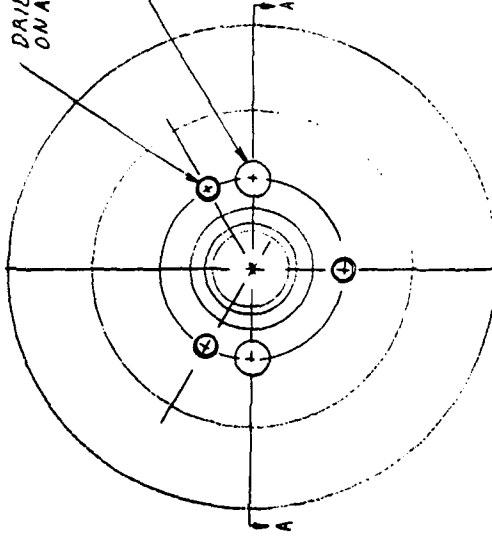

DRILL THRU $\frac{3}{4}$ " + TAP
 $\frac{3}{4}$ "-10

DRILL #7 + TAP $\frac{1}{4}$ "-20
THRU ONE SIDE FOR
SETSCRE W (NYLON)

CHAMFER $\frac{1}{32}$ " @ 30°

Tolerances		DATE		WOODS HOLE OCEANOGRAPHIC INSTITUTION	
Finishes	Dimensions	APRIL 8, 1952	Ocean Systems & Moorings Lab		Ocean Engineering Dept.
$\pm \frac{1}{4}$	$\pm .005$	DRAFT	S. KERY		
Material		PROJ. NO.		REV. B	
STEEL		100 112.00		DWG. No. B 424	
		APPVD		Sheet 2 of 6	
		SCALE			
		FULL			

SLIP RING STEM FOR CAPTOR

GROOVE FOR 2-022 O-RING DEPTH .051 ±.002
 GROOVE DIA = 1.129 ±.002

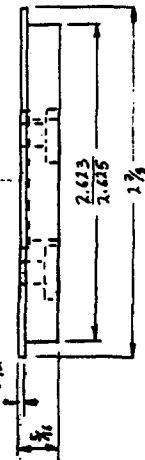
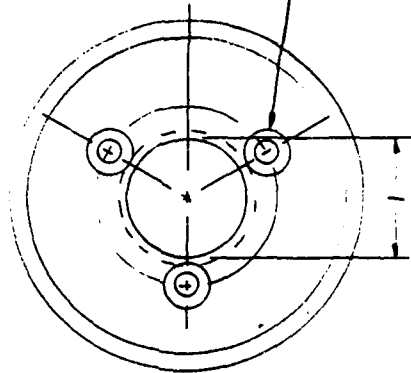
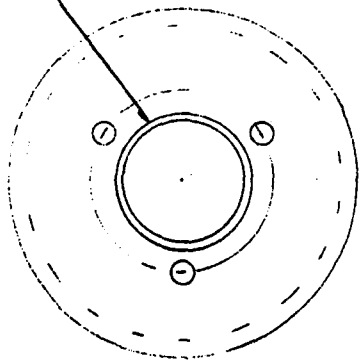

BOTTOM VIEW

DRILL THRU 3/16" COUNTER BORE 3/16" DIA.
 FOR #10 SEAL SCREWS, (3) PLACES
 120° APART ON A 1.5" DIA. BC.

Title Block		DATE		APRIL 10, 1962	
Description		DRAFT		S. HEARY	
Part No.		PROJ. NO.		100142-00	
Material		APPVD		FULL	
DELTRIN		SCALE		FULL	
WOODS HOLE OCEANOGRAPHIC INSTITUTION OCEAN SYSTEMS & MOORINGS LAB OCEAN ENGINEERING DEPT.		DWG. NO.		B 425	
BOTTOM SEAL FOR CAPTOR SLIP RING		REV.		B	
				Sheet 2 of 6	

DRILL THRU $\frac{13}{16}$, 4 PLACES ON A $4\frac{1}{2}$ " DIA B.C.

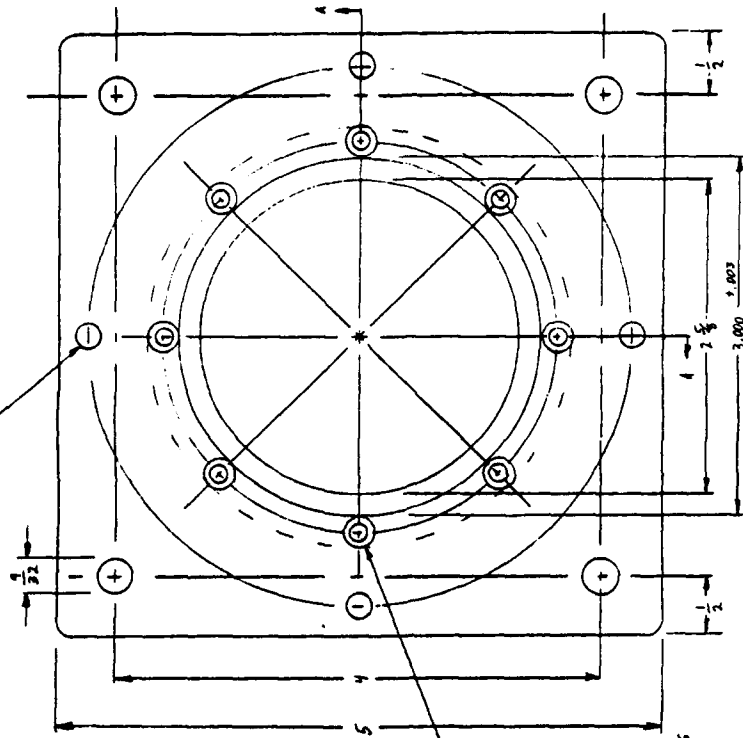

DRILL THRU $\frac{3}{4}$ (Ø) PLACES EQUALLY SPACED ON A 3" B.C. + COUNTER SINK 100° FOR 6-32 FLAT HEAD SCREWS

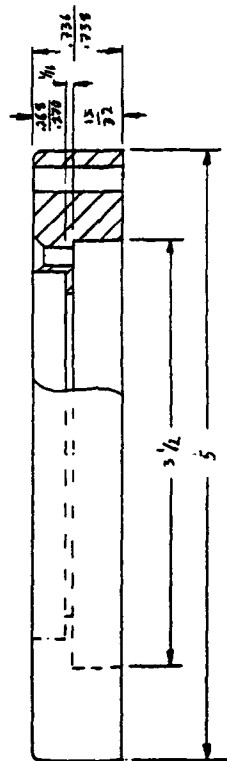

Woods Hole Oceanographic Institution Ocean Systems & Mooring Lab Ocean Engineering Dept.		DATE } APRIL 10 1974 DRAFT } S. KERY PROJ. NO. } 100192.00 APPVD } SCALE } FULL	DWG. No. } P 426 REV. } B Sheet Y of C
Fabrication Decimals Angles	± .01 ± .05 SHD=11	Material STEEL	SLIP RING BOX LID

UNILLY 100 IN 20 51 12 DEET 7 1000000

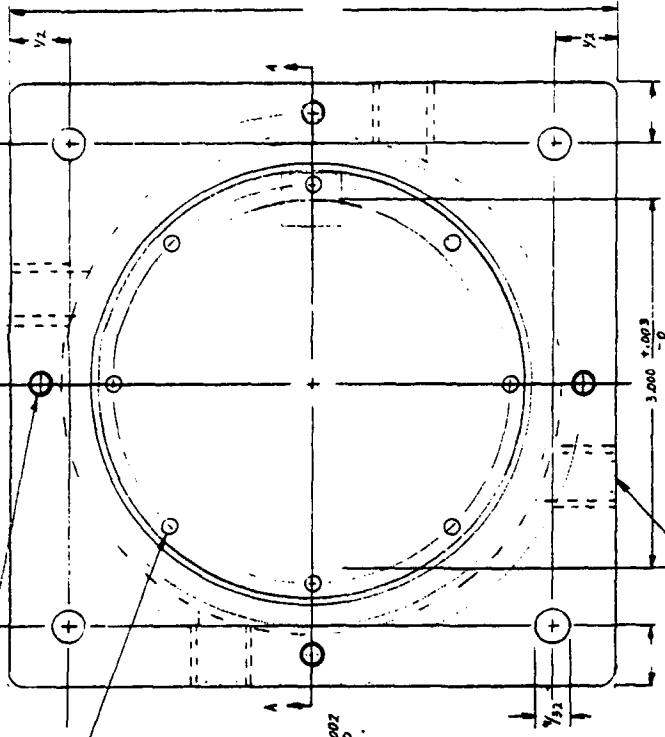

DRILL $\frac{1}{8}$ " BY $\frac{3}{16}$ " DEEP (8) PLACES
45° APART DIA 1.500 B.C.

GROOVE FOR 2.240 O-RING, DEPTH = .002

DRILL $\frac{3}{16}$ " TO INTERSECT, TAP $\frac{1}{4}$ "-18, ONE PLACE EACH SIDE
 $\frac{3}{4}$ " LEFT OF CENTER OF SIDE, $\frac{25}{32}$ " DIA. FROM TOP EDGE

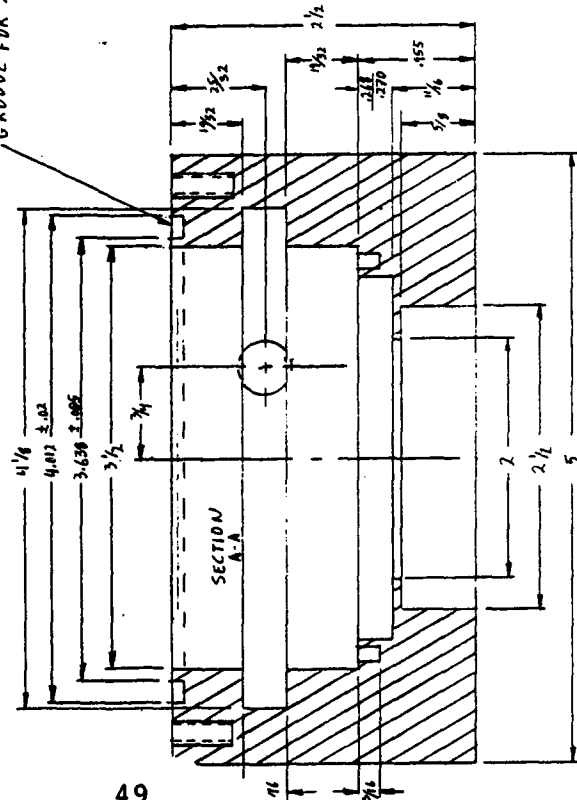

Woods Hole Oceanographic Institution Ocean Structure & Moorings Lab Ocean Engineering Dept.		DATE APRIL 9, 1952 DRAFT S. KERY PROJ. NO. 100192.00 APPVD SCALE FULL	DWG. No. B427 REV. B Sheet 5 of 6
BASE BLOCK FOR CAPTOR SLIPRING ASSY		Material DELRIN	

DRILL #36 + TAP 6-32 BY 1/4" DEEP, C BORE 1/4" DIA
BY .050 ±.002-0 DEEP

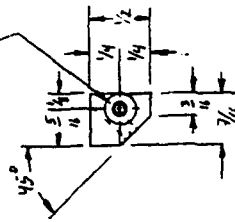
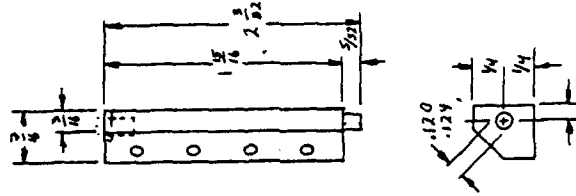

DRILL #36 THRU + TAP 6-32 (4)
PLACES AS SHOWN

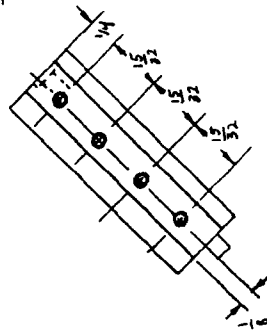

9 REVD

Woods Hole Oceanographic Institution Ocean Systems & Mooring Lab Ocean Engineering Dept.		DATE	APRIL 10, 12
CONTACT POSITS FOR CAPTOR SLIPRING		DRAFT	S. KERY
		PROJ. NO.	100192.00
		APPVD	
		SCALE	FULL
		Material DELKIN	
		DWG. No. B 426	
		REV. A	
		Sheet 6 of 6	

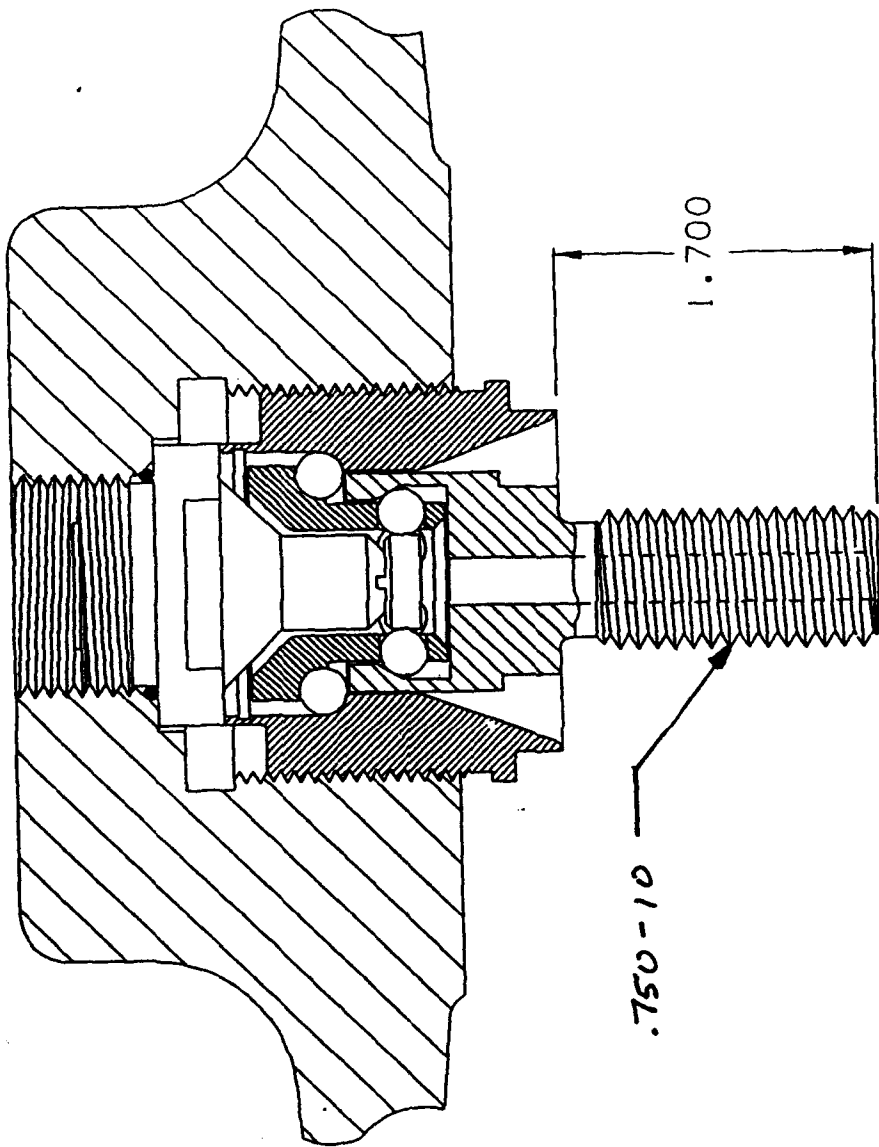

SHACKLE ASSEMBLY

SHACKASY.PRT
2/12/92 DHW

CABLE CONNECTION ASSEMBLY

Drill thru 11/16" & tap 3/4"-16 UNF
2 inches deep on center.

Drill thru 7/16" & tap 1/4" NPT one
place as shown on a 1-3/32" radius
bolt circle for oil fill plug.

Drill thru & tap 9/16"-18 UNF two
places as shown on a 1-3/32" radius
bolt circle.

Drill thru # 7 & tap 1/4"-20 UNC six
places, equally spaced on a 1.800"
radius bolt circle.

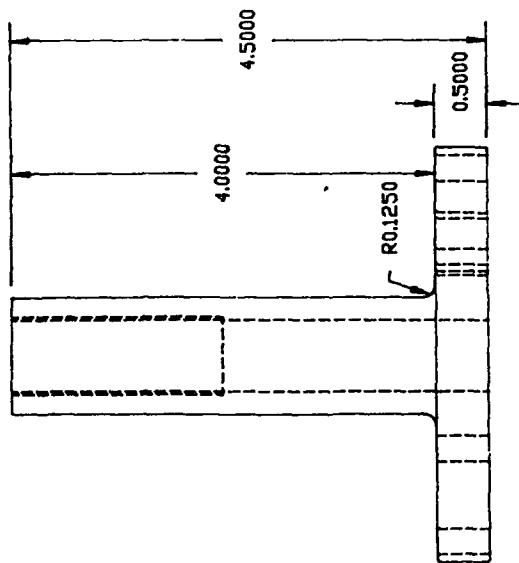
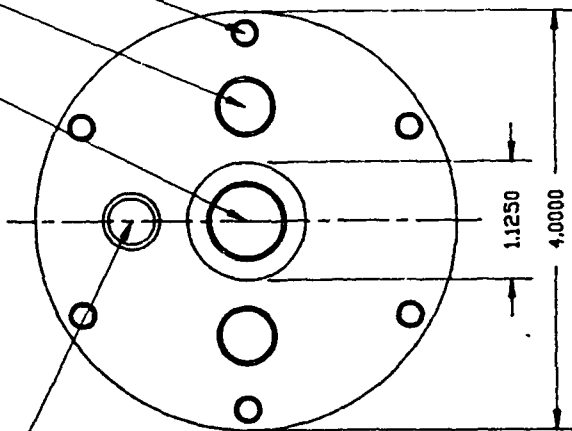

Tolerances		Date	December 21, 1971
Dimensions	±.0005	Drawn	S. Kery
Fit	±.0005	Checked	
Material	Steel	App'd	
Scale	Full		

Woods Hole Oceanographic Institution
Applied Ocean Physics and Engineering
Ocean Systems & Moorings Lab
Load cell mount for CAPTOR mooring cable
terminations.

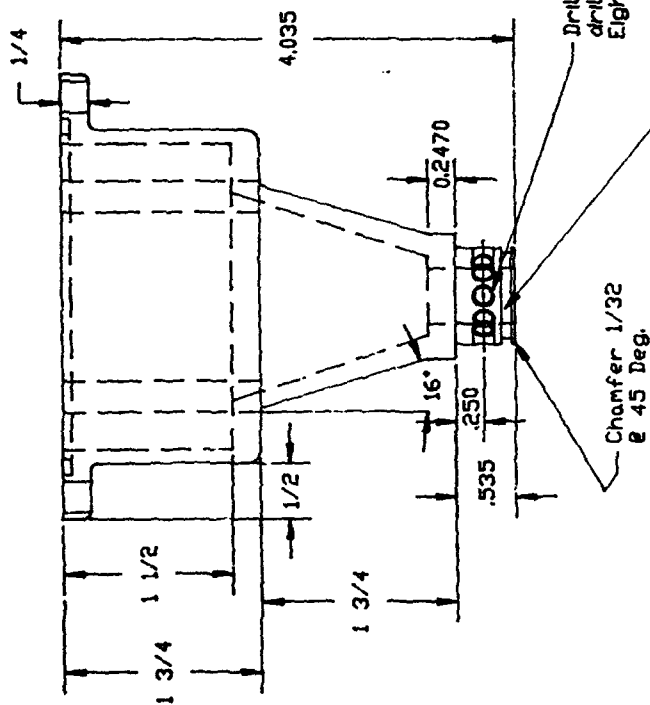

Drill & Tap 10-32 by .156 deep. Do NOT drill thru. Tap as far as possible. Eight places evenly spaced as shown.

Groove for D-Ring #2-018, Plug dia = .866
Groove Dia = 0.768 $\pm .001$, $- .001$
Groove width = .093 $\pm .002$, $- .000$

Groove for 2-151 O-ring, depth = .081, $\pm .002$, $- .0$

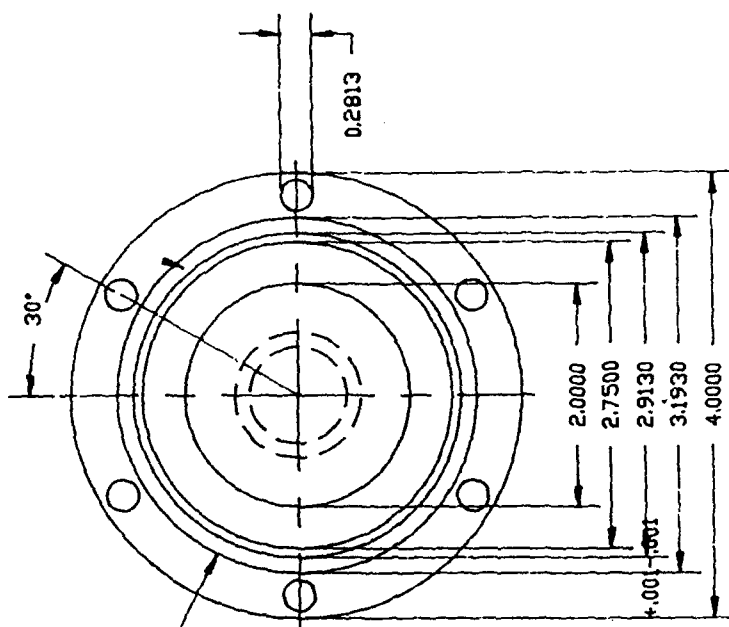

Year/Week		Date November 191991	VOBBS HOLE OCEANOGRAPHIC INSTITUTION APPLIED OCEAN PHYSICS & ENGINEERING OCEAN SYSTEMS & MOORINGS LAB.
Checked	Made	Draft S. Kerry	
+/- 1/64/- .002/- 1 Deg		Proj. No. 100192.00	Caption Mooring Hose Termination Bell Fitting
Material		Appvd	
17-4 PH Stainless Steel H 1150 Condition		Scale Full	

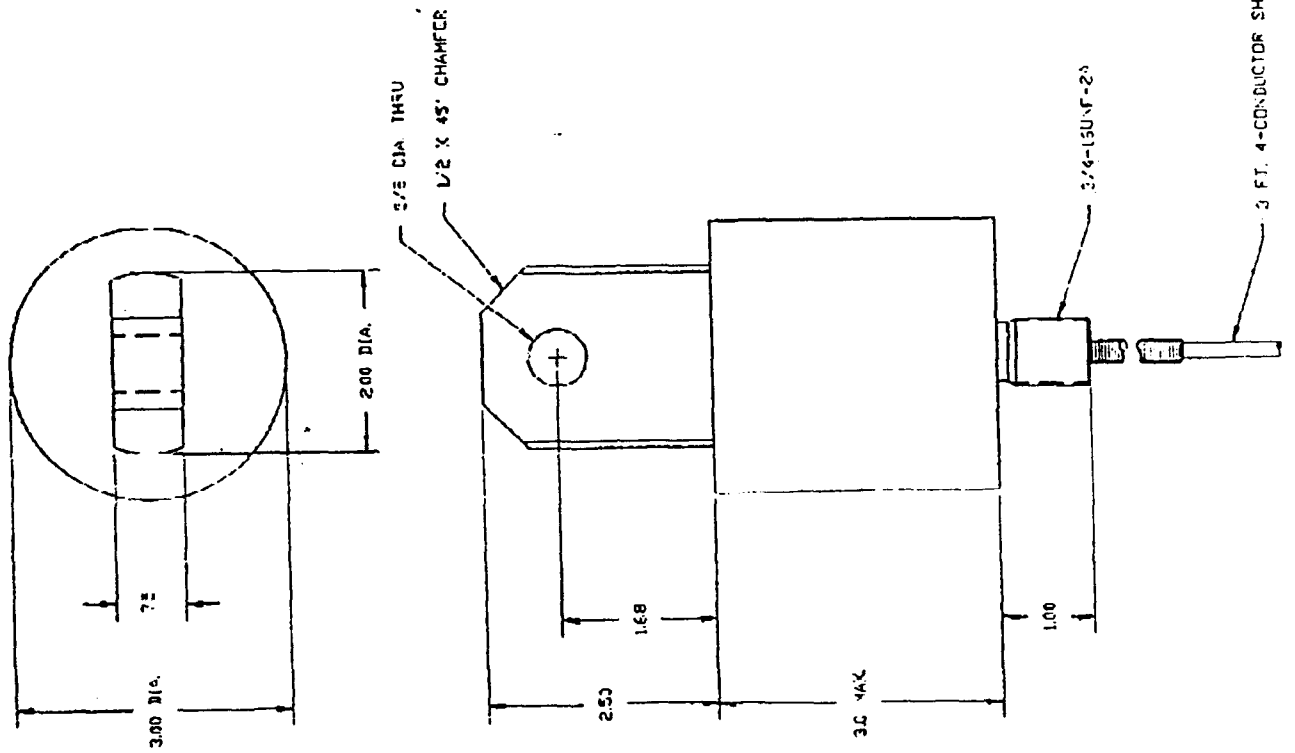

EXCITATION VOLTAGE	10V AC-DC, 15V MAX
FULL SCALE OUTPUT (F.S.O.)	2 mV/V
INPUT RESISTANCE (O-MS)	350 MIN
OUTPUT RESISTANCE (O-MS)	350 ± 5
NONLINEARITY (% F.S.O.)	0.25
HYSTERESIS (% F.S.O.)	Combined
REPEATABILITY (% F.S.O.)	0.10
HYDROSTATIC EFFECT ON ZERO BALANCE PER LOG PSI (% F.S.O.)	+/-1.0
BALANCE	0.005
ZERO TEMPERATURE ERROR (% F.S.O./°F)	0.005
SPAN TEMPERATURE ERROR (% READING/°F)	0 TO +150
COMPENSATED TEMPERATURE RANGE (°F)	0 TO +200
OPERATING TEMPERATURE RANGE (°F)	150
SAFE OVERLOAD (% OF CAPACITY)	300
ULTIMATE OVERLOAD (% OF CAPACITY)	100 MAX
HYDROSTATIC PRESSURE (PSI)	17-4 PH Stainless Steel
MATERIAL	
WIRING CODE	+OUTPUT Green -OUTPUT White -INPUT Black +INPUT Red Yellow SHIELD

HYDRONICS CONTROL DIV
(2000 LBS. CAPACITY)

HYDRONICS
ESTABLISHED 1940

 * T-HYDRONICS, INC. *

FORCE TRANSDUCER CALIBRATION CERTIFICATE

MODEL: TH-UWM
 SERIAL NUMBER: 48853
 CAPACITY: 2000 LBS.
 EXCITATION: 10 VDC

PERCENT OF CAPACITY	MV/V OUTPUT
0%	0
50%	0.9981
100%	2.0043
50%	0.9987
0%	0

INPUT RESISTANCE (OHMS): 429
 OUTPUT RESISTANCE (OHMS): 352
 ZERO BALANCE (MV/V): 0.0080
 COMPENSATED TEMPERATURE RANGE: 0 TO 150
 (DEGREES FAHRENHEIT)

ELECTRICAL CONNECTIONS:

+INPUT RED
 -INPUT BLACK
 +OUTPUT GREEN
 -OUTPUT WHITE

QUALITY ASSURANCE: *RL*

DATE: 2/5/92

 * T-HYDRONICS, INC. *

FORCE TRANSDUCER CALIBRATION CERTIFICATE

MODEL: TH-UWM
 SERIAL NUMBER: 48854
 CAPACITY: 2000 LBS.
 EXCITATION: 10 VDC

PERCENT OF CAPACITY	MV/V OUTPUT
0%	0
50%	1.0026
100%	2.0030
50%	1.0030
0%	-.0001

INPUT RESISTANCE (OHMS): 438
 OUTPUT RESISTANCE (OHMS): 352
 ZERO BALANCE (MV/V): -.0088
 COMPENSATED TEMPERATURE RANGE:
 (DEGREES FAHRENHEIT) 0 TO 150

ELECTRICAL CONNECTIONS:

+INPUT RED
 -INPUT BLACK
 +OUTPUT GREEN
 -OUTPUT WHITE

QUALITY ASSURANCE: *R*
 DATE: 2/5/92

MOORING CABLE TEST REPORT

MARTIN MARIETTA

AERO & NAVAL SYSTEMS
OCEAN SYSTEMS OPERATIONS
6711 BAYMEADOW DRIVE
GLEN BURNE, MD 21060

HO Bureau

CONTRACT NO. P0-05040

PROJECT NO. _____

REPORT NO. WHOI-01

DATE OF ISSUE APRIL 6, 1992

TITLE

ACCEPTANCE TESTING OF VECTRAN
HS REINFORCED HOSE ASSEMBLIES
FOR A WOODS HOLE OCEANOGRAPHIC
BUOY MOORING TETHER

PREPARED BY Walter Paul

REFERENCE _____

REVIEWED BY _____

APPROVED BY _____

APPROVED BY _____

NO. OF PAGES 1 OF 8

& Appendixes

ACCEPTANCE TESTING OF VECTRAN HS REINFORCED HOSE ASSEMBLIES FOR A WOODS HOLE OCEANOGRAPHIC BUOY MOORING TETHER

1.0 INTRODUCTION

The Ocean Systems and Mooring Laboratory of the Woods Hole Oceanographic Institution (WHOI) entered into a contract with Martin Marietta's Aero and Naval Systems Division (MMANS) to procure and test hose assemblies to be used in an engineering subsurface test mooring. This report documents the acceptance tests for the procured hose assemblies, the tests were performed during the first week of February 1992 at Martin Marietta's Glen Burnie facility and were witnessed by Sean Kerry of WHOI, and by Mark Kumagai, Brian Pak, Howard Steves and Gerhard Winkler from the Naval Surface Weapons Center (NSWC). Main purpose of the test effort was to ensure that a maximum service load of 2,000 lbs can be supported by the hose assembly, and that the hoses will respond to sustained longitudinal mooring tension with a minimum creep.

2.0 DESCRIPTION OF HOSE ASSEMBLIES

The fabricated assemblies use polyurethane hose of 1.14 inch outer diameter and 0.825 inch inner diameter, which is terminated with swaged titanium end-couplings. The hose from polyether-polyurethane is heavily reinforced with 36 cabled cords, each with 550 lbs minimum breaking strength, from VECTRAN HS fibers. Vectran HS is a polyester-polyarylate fiber made from Vectra Liquid Crystal Polymer (LCP), which has similar tensile behavior as Kevlar-29 and is manufactured by the Hoechst-Celanese Corporation. The fiber has about 10 times better resistance against abrasion than Kevlar and seems not to suffer from destructive kink-band formation. Vectran HS shows very little creep under sustained loads. The reinforcing cords are arranged longitudinal and evenly distributed inside the extruded polyurethane hose wall. Due to the lack of circumferential reinforcement the hose wall can not support internal high fill fluid pressure without permanent diameter growth, normal fill pressure should be kept at 8 +/- 2 psi. The hose end-couplings can only reliably support about one quarter of the cords' combined breaking strength - reduced by a safety factor of 2 - due to the need to minimize the coupling length to facilitate reeling, and due to unavoidable reduction in strength efficiency of the 36 parallel arranged cords in the hose wall.

3.0 THE PROBLEM OF FOLD FORMATION OF THE HOSE DURING BENDING

3.1 Permanent Fold Deformation of Mooring Hose in Bending

The hose responds with less than 1.5 percent stretch to a 2,000 lbs axial tension. This considerable axial stiffness creates a problem when the hose is bent around any but very large diameters (over 9 ft). The reinforcing cords have an elastic modulus in the 3 to 5 million psi range, the thin-walled urethane hose has low rigidity in compression. During a bend the neutral axis of the hose shifts into the hose surface at the outside of the bend. The empty hose - without solid internal fill - responds to bending by forming strong folds. These

folds form in irregular intervals sometimes as close as 3 to 12 inches apart in sharp bends. At each fold the hose on the inside of the bend is forced against the hose surface at the outside of the bend. Through this geometric deformation into a fold the needed shortening of the hose on the inside of the bend is achieved, which allows the bending of the hose even around small bend diameters with little resistance. The urethane responds to this drastic fold deformation with yielding and permanent deformation. The hoses had many of these fold caused deformations "frozen in" from lengthy storage on a 5 ft diameter reel. (If the hose would be solidly filled or built with a thick hose wall, significant bend stiffness would develop, since the hose can not flatten and fold.)

3.2 Removal and/or Minimizing of Fold Deformations in Mooring Hose

MMANS removed the deformations through a special heat treatment of the hose, where 180 degree F hot water was pumped through the hose interior, while the hose was contained inside and pressed against external metal split pipes halves, clamped together for the heat treatment process. The permanent fold deformations were completely removed with the heat and pressure process in which the urethane becomes soft and pliable enough to go back into its original cylindrical hose wall position.

However new folds will form again when the heat treated hose is stored on a reel or bent otherwise. But the deformation is much less severe, when the hose is stored in a straight fashion after only one or two days storage on reels with the largest possible barrel diameter (preferably larger than 9 ft). The less severe deformations could potentially be removed with locally applied heat (electric heater blower, keep maximum hose temperature below 200 degrees F). WHOI responded to the hose folding problem by building a large custom reel for truck shipment to minimize the severity of the folds. The hoses were also oilfilled before shipment and lightly pressurized, which provides some resistance against folding of the hose, and were immediately after arrival removed from the reel and stored inside straight plastic pipes.

4.0 THE TEST PROGRAM

4.1 Test Instructions by WHOI, Test Samples, Test Equipment

The tests were conducted following the instructions of WHOI's Acceptance Testing of Reinforced Hose Mooring Tether, Revision 6, November 1991, with some changes agreed to by WHOI and NSWC during the test effort to best characterize the hose assemblies under test. The tests determined the load-elongation behavior of the hose assemblies, and their creep response to sustained tensions.

Tested were two short hose assemblies of 56 inch length - Samples A & B - and two approximately 64 ft long units, Samples C & D. The short samples were tested using a Tinius Olsen Low-Cap tensile vertical test machine. The 64 ft units were tested in a 180 ft long horizontal tensile proof testere using a rope winch to apply the needed tension. Both test machines are located at MMANS Glen Burnie facility. Steel tapes were positioned with loose marker tape loops along each hose under test to measure length changes to about 1/16 of an inch.

4.2 Results of Tests on Short Hose Assemblies - Samples A & B

Test 1 of WHOI's acceptance testing instructions for Samples A & B requires determination of the elongation of the hose assembly samples between 0 - 25 lbs and 2,000 lbs tension in three subsequent loading cycles. Results of these tests are shown in Figure 1, with a maximum measured elongation under 2,000 lbs tension of 1.20 percent. This is less than the specified upper stretch limit of 3 percent at 2,000 lbs.

Test 2 measured creep during 24 hours under 2,000 to 2,500 lbs tension. (Lack of continuous monitoring of test machine through a technician required overloading above 2,000 lbs to assure that tension would not drop below 2,000 lbs between creep data measurements). During the 24 hour test period the elongation of hose sample B increased from 1.28 to 1.50 percent, 90 percent of this length increase had occurred after about 4 hours under load. Sample A was also held for 24 hours under the same load range, but creep data were not taken.

Test 3 was specified as a 20 minute test under 3,000 lbs with monitoring of creep behavior, Test 4 as a break test for Sample A only. Due to the stable load elongation and creep behavior it was decided to modify Tests 3 and 4. Sample A was loaded for 20 minutes to 4,000 lbs, stretched 1.76 percent, and developed 0.176 percent creep. Samples A & B were subsequently loaded to 5,000 lbs for 1 minute. No sign of hose deterioration at the coupling interfaces was observed, both hoses had a 1.78 percent elongation under 5,000 lbs. No break test was performed in order to keep the 56 inch test samples intact for further investigations.

4.3 Results of Tests on Long Hose Assemblies, Samples C and D

These hose assemblies were subjected to 3 load cycles between 25 and 2,000 lbs and subsequently held for at least 12 hours at 2,000 lbs - Tests 5 & 6, a repeat of Tests 1 and 2. The long hose assemblies confirmed the stable load elongation behavior of the short hose assemblies. The results are shown in Figure 2 and are identical for Samples C & D within reading error tolerances.

4.4 Summary of Test Results

Results of all tests are summarized in Table 1. They show close agreement between the short samples A & B, and between the long samples C & D. The presence of a catenary pretension of the long hose assemblies on the horizontal test machine may have contributed to the test result differences between the long and the short hose assemblies. Also contributed to the differences may have the lower deformation control due to the use of a rope winch drive to develop the tensions in the long hose. The absolute values of elongation and creep are very small and should help in the planned instrumented mooring tether application.

Woods Hole Oceanographic Institution accepted the hose assemblies based on the demonstrated low stretch and creep response to the applied test tensions.

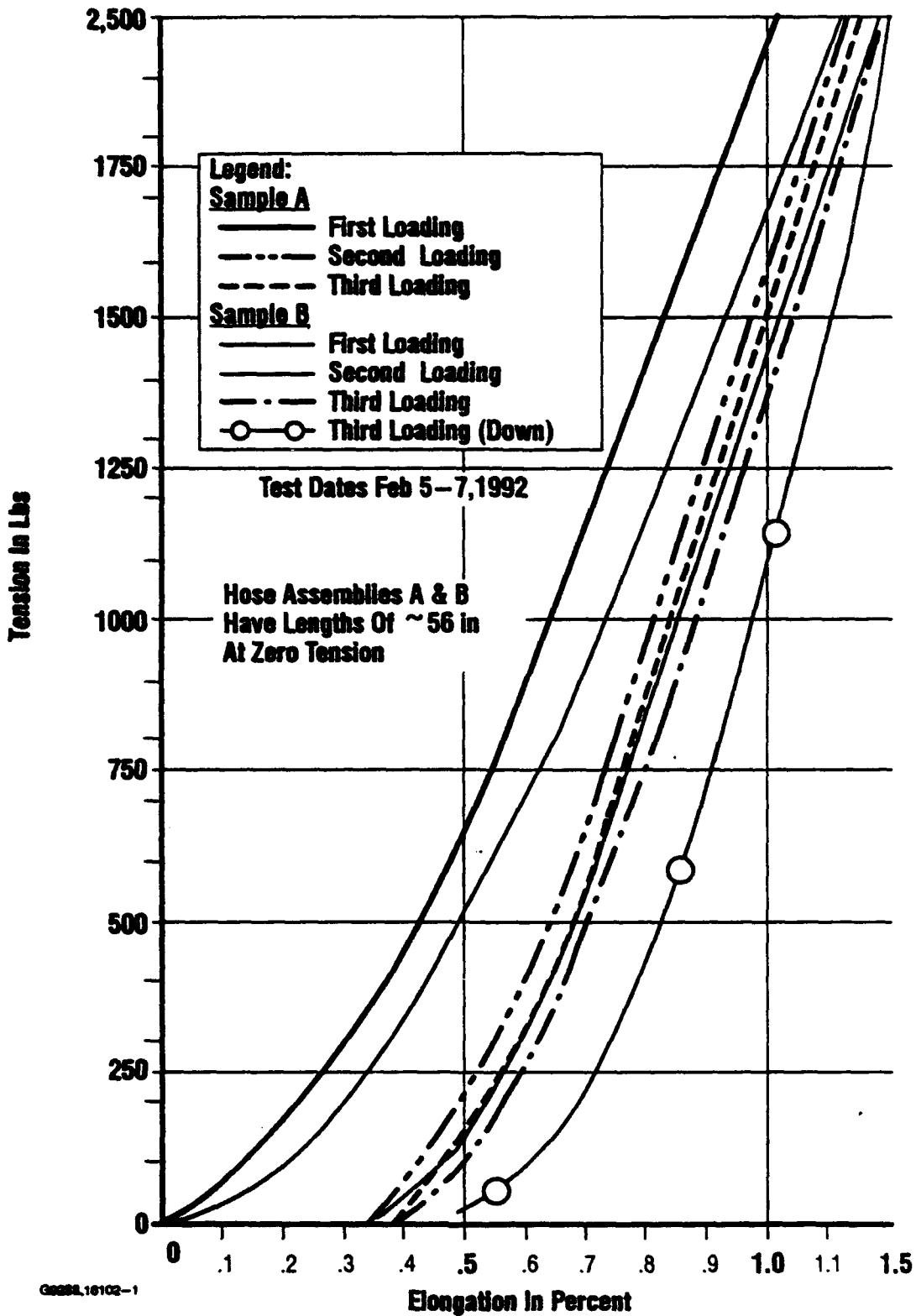

Figure 1. Load-Elongation Behavior of Hose Assemblies A and B, Load Cycles 1 Through 3 Between 0 and 2,000 lbs.

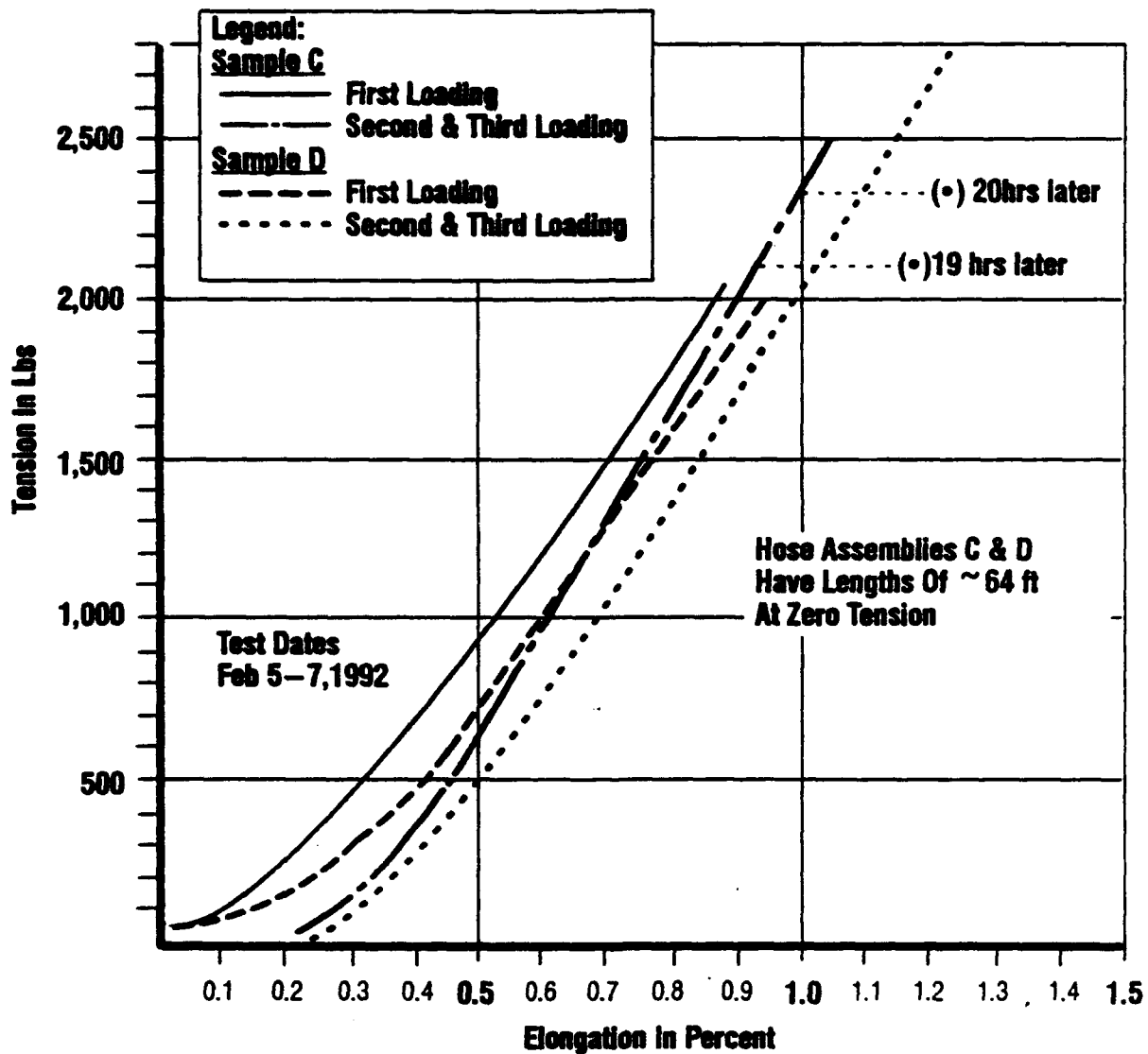

Figure 2. Load-Elongation Behavior of Hose Assemblies C and D, Load Cycles 1 Through 3 Between 30 and 2,000 lbs, Also 24 Hour Loading Between 2,000 and 2,500 lbs.

Test Description	Percent Elongation Response to Tensions:			
	Sample A	Sample B	Sample C	Sample D
<u>Three Load Cycles to 2000 lbs</u>				
Cycle 1 at 2000 lbs:	1.00	1.14	0.95	0.87
Cycle 2 at 2000 lbs:	1.12	1.18	0.93?	0.88
Cycle 3 at 2000 lbs:	1.14	1.19	0.99	0.90
<u>Creep After 24 hrs @ 2000 lbs:</u> no data		0.28	0.162	0.106
<u>Creep After 20 min @ 4000 lbs:</u>	0.176	no data	no data	no data
<u>Elongation under 5,000 lbs:</u>	1.78	1.78	no data	no data

Notes: Less than 3 % elongation specified for 3 load cycles to 2,000 lbs:
 Creep after 24 hours under 2,000 lbs to be 1 % maximum;
 Creep after 20 minutes under 3,000 lbs 1.5 % maximum.

Table 1: Listing of Elongation and Creep Test Data of Mooring Tether Hose

APPENDIX B: Electrical Design Documentation

AMT DATA

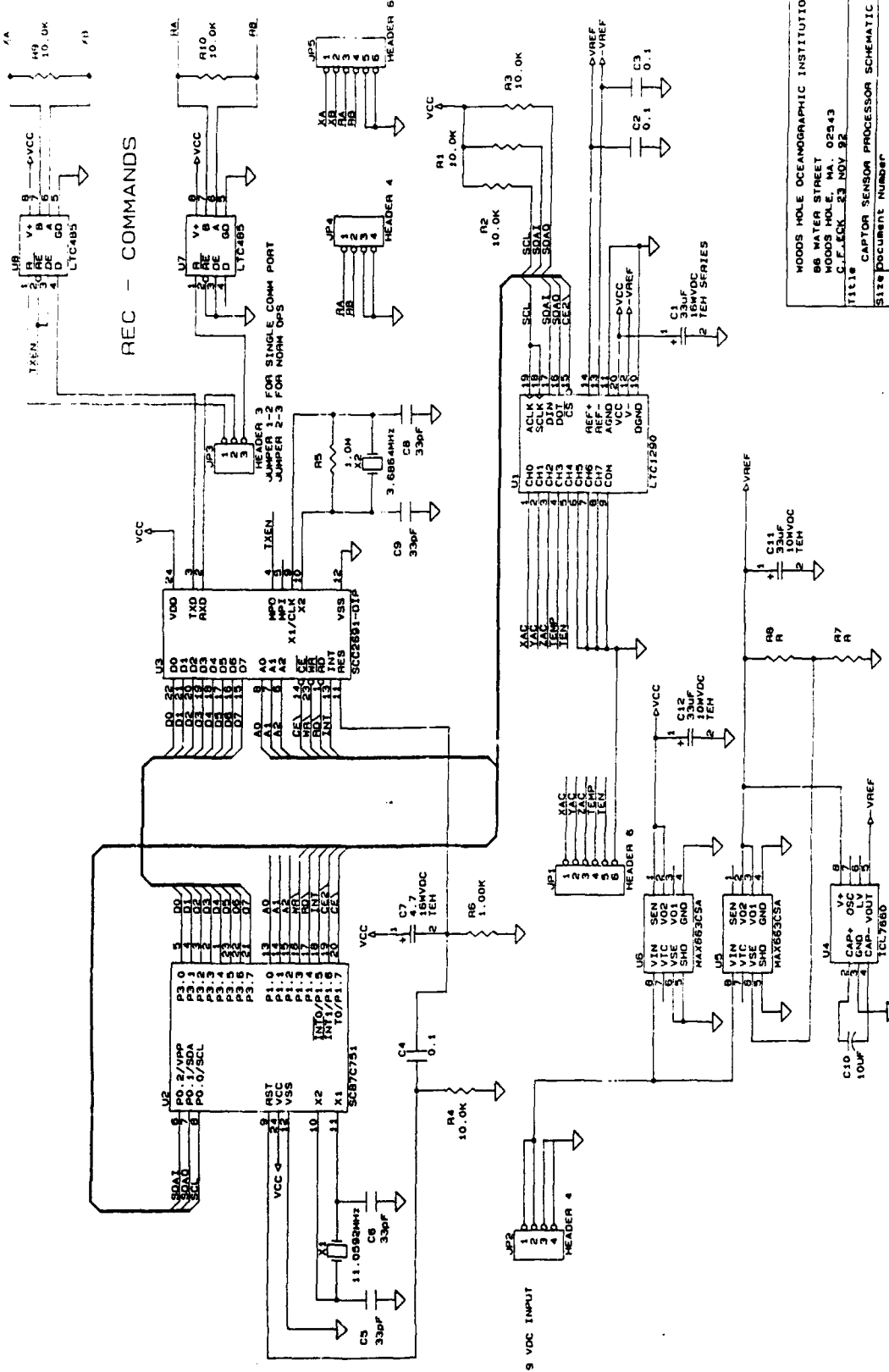

REC - COMMANDS

HOODS HOLE OCEANOGRAPHIC INSTITUTION	
88 WATER STREET 02543	
HOODS HOLE MA	
C.F.ECK 23 NOV 92	
Titl:	CAPTOR SENSOR PROCESSOR SCHEMATIC
Site Document Number:	B CAPSENSR SCH
REV	0

DATE: NOVEMBER 23, 1992 ENTRY: 07

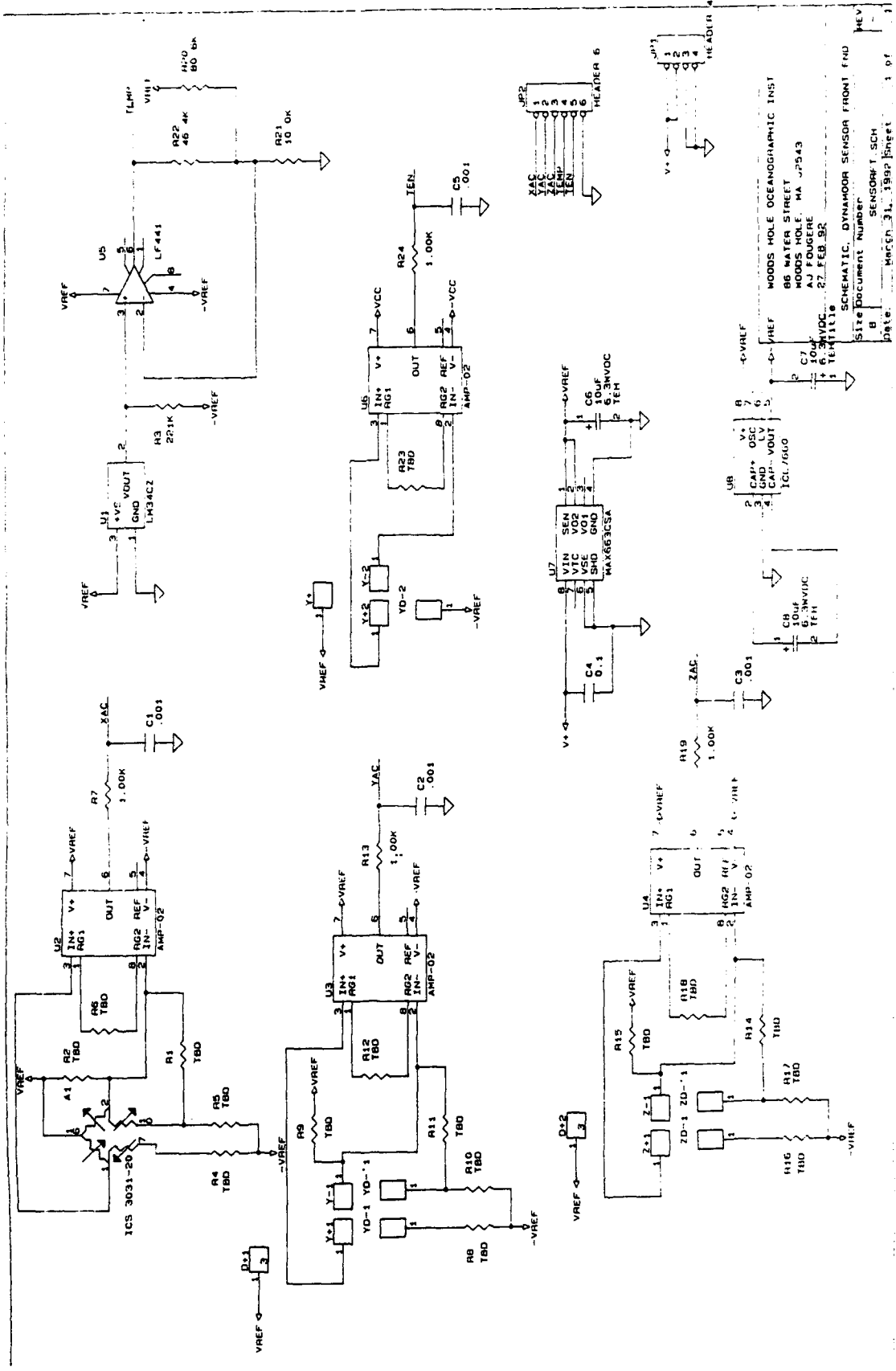

WOODS MOLE OCEANOGRAPHIC INST
 86 WATER STREET
 WOODS MOLE, MA 07543
 AJ FOURIER
 TEL: 711-1111
 SCHEMATIC, DYNAMOOR SENSOR FRONT END

Site Document Number: SENSOFR1.SCH
 Date: Mar 31, 1989 Sheet 1 of 1

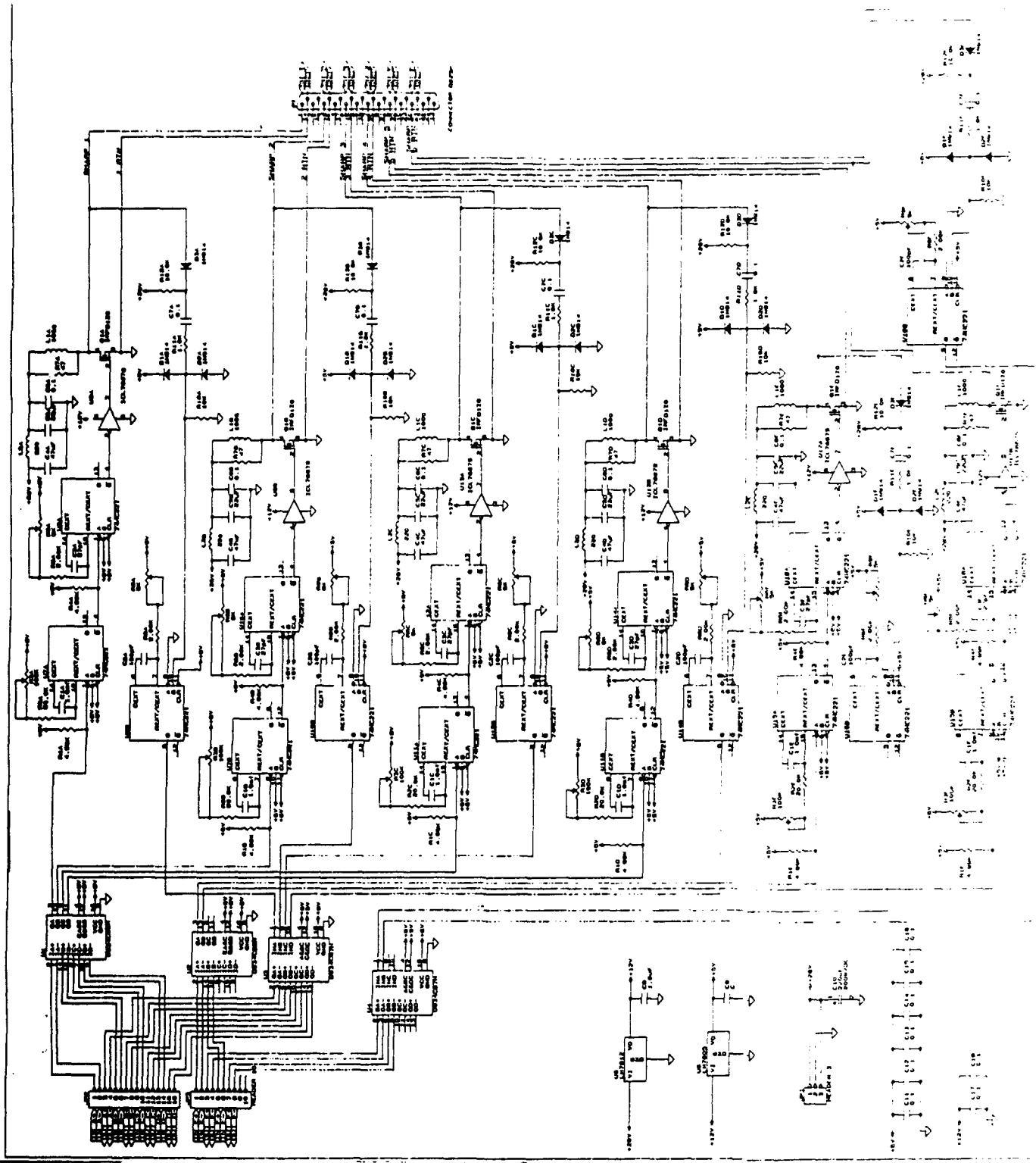

HOODS HOLE OCEANOGRAPHIC INSTITUTION	
88 WATER STREET	
HOODS HOLE, MA 02543	
TITLE: CAL. ECK - 30 DEC 81	
SCHEMATIC: SHARPS TAXI INT. 81-DIRECTIONAL	
Site document number	SHARPINTP.SCH
REV	REV
C	C
DATE: NOVEMBER 18, 1982	DATE: 11 18 1982

DOWN FROM SHARPS TRANSCEIVER

RS485 DOWN TO TAXI

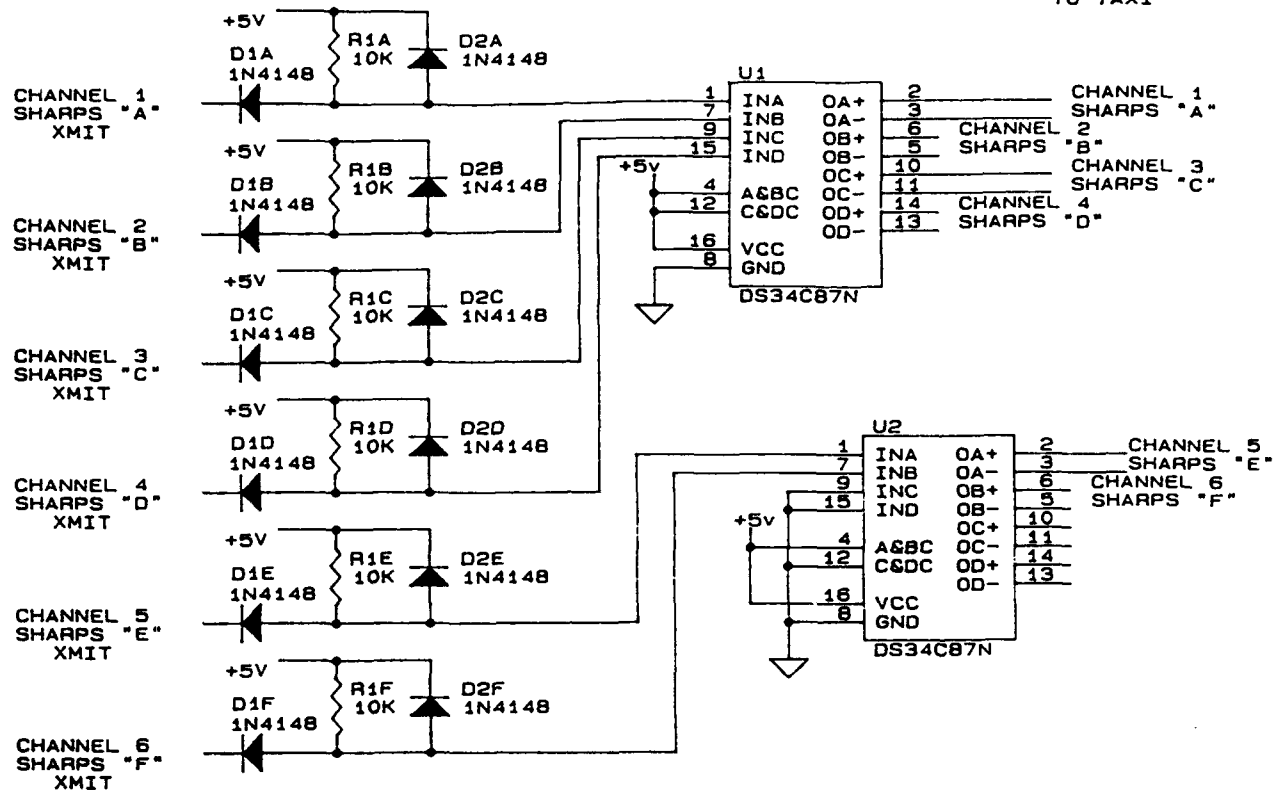

UP TO SHARPS TRANSCEIVER

RS485 UP FROM TAXI

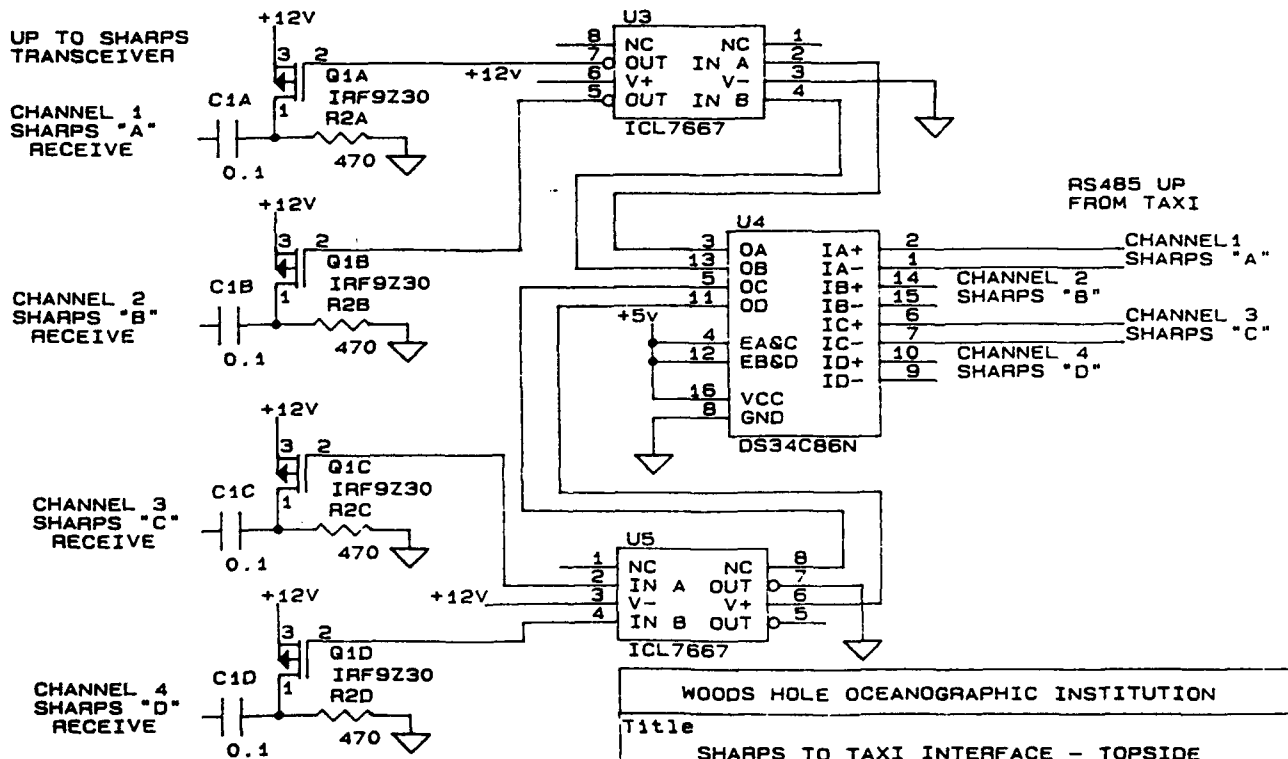

WOODS HOLE OCEANOGRAPHIC INSTITUTION		
Title		
SHARPS TO TAXI INTERFACE - TOPSIDE		
Size	Document Number	REV
A	SRPINTR.SCH	0
Date:	November 23, 1992	Sheet 1 of 1

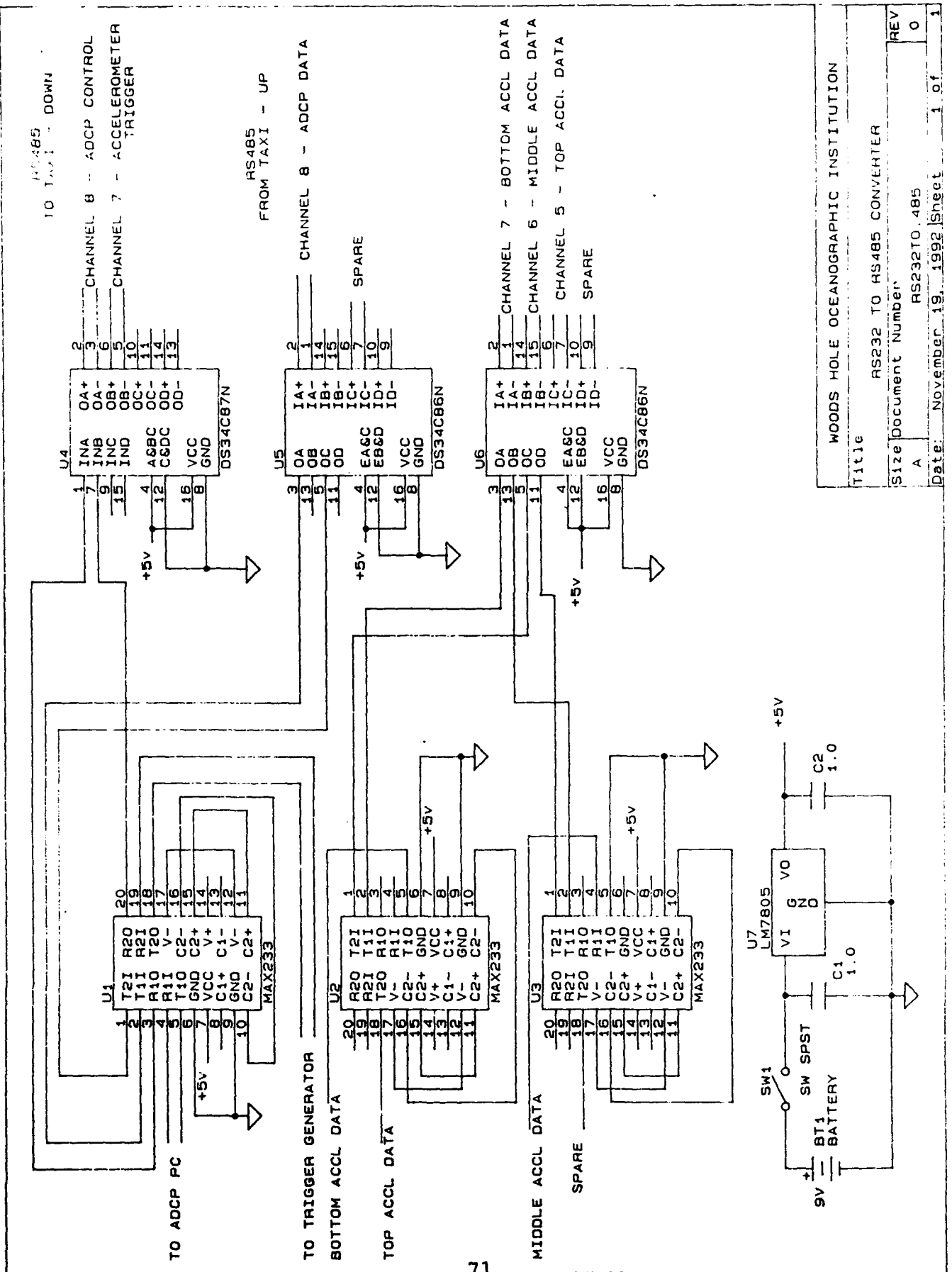

RS485
TO TAXI - DOWN

CHANNEL 8 - ADCP CONTROL
CHANNEL 7 - ACCELEROMETER TRIGGER

RS485
FROM TAXI - UP

CHANNEL 8 - ADCP DATA

SPARE

CHANNEL 7 - BOTTOM ACCL DATA
CHANNEL 5 - MIDDLE ACCL DATA
CHANNEL 8 - TOP ACCL DATA
SPARE

U4
1 INA
2 OA+
3 OA-
4 ASBC
5 INC
6 INB
7 IND
8 VCC
9 OC+
10 OC-
11 OD+
12 OD-
13 GND
14
15
16
17
18
19
20

U5
1 IA+
2 IA-
3 IB+
4 IB-
5 IC+
6 IC-
7 ID+
8 ID-
9 EASC
10 EB&D
11 VCC
12 V-
13 V+
14 GND
15
16
17
18
19
20

U6
1 IA+
2 IA-
3 IB+
4 IB-
5 IC+
6 IC-
7 ID+
8 ID-
9 EASC
10 EB&D
11 VCC
12 V-
13 V+
14 GND
15
16
17
18
19
20

U1
1 T2I
2 R2I
3 T1I
4 R1I
5 T1O
6 R1O
7 V-
8 V+
9 GND
10 C2+
11 C2-
12 C1+
13 C1-
14 GND
15 C2+
16 C2-
17 T2O
18 R2O
19 T1O
20 R1O

U2
1 T2I
2 R2I
3 T1I
4 R1I
5 T1O
6 R1O
7 V-
8 V+
9 GND
10 C2+
11 C2-
12 C1+
13 C1-
14 GND
15 C2+
16 C2-
17 T2O
18 R2O
19 T1O
20 R1O

U3
1 T2I
2 R2I
3 T1I
4 R1I
5 T1O
6 R1O
7 V-
8 V+
9 GND
10 C2+
11 C2-
12 C1+
13 C1-
14 GND
15 C2+
16 C2-
17 T2O
18 R2O
19 T1O
20 R1O

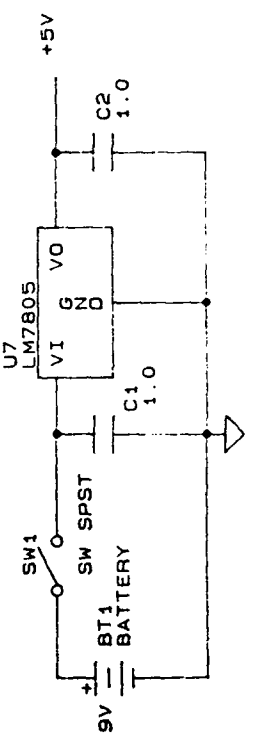

WOODS HOLE OCEANOGRAPHIC INSTITUTION	
Title	RS232 TO RS485 CONVERTER
Size	Document Number
A	RS232TO.485
Date	November 19, 1992
Sheet	1 of 1
REV	0

DOCUMENT LIBRARY

Distribution List for Technical Report Exchange - July 1, 1993

University of California, San Diego
SIO Library 0175C (TRC)
9500 Gilman Drive
La Jolla, CA 92093-0175

Hancock Library of Biology & Oceanography
Alan Hancock Laboratory
University of Southern California
University Park
Los Angeles, CA 90089-0371

Gifts & Exchanges
Library
Bedford Institute of Oceanography
P.O. Box 1006
Dartmouth, NS, B2Y 4A2, CANADA

Office of the International Ice Patrol
c/o Coast Guard R & D Center
Avery Point
Groton, CT 06340

NOAA/EDIS Miami Library Center
4301 Rickenbacker Causeway
Miami, FL 33149

Library
Skidaway Institute of Oceanography
P.O. Box 13687
Savannah, GA 31416

Institute of Geophysics
University of Hawaii
Library Room 252
2525 Correa Road
Honolulu, HI 96822

Marine Resources Information Center
Building E38-320
MIT
Cambridge, MA 02139

Library
Lamont-Doherty Geological Observatory
Columbia University
Palisades, NY 10964

Library
Serials Department
Oregon State University
Corvallis, OR 97331

Pell Marine Science Library
University of Rhode Island
Narragansett Bay Campus
Narragansett, RI 02882

Working Collection
Texas A&M University
Dept. of Oceanography
College Station, TX 77843

Fisheries-Oceanography Library
151 Oceanography Teaching Bldg.
University of Washington
Seattle, WA 98195

Library
R.S.M.A.S.
University of Miami
4600 Rickenbacker Causeway
Miami, FL 33149

Maury Oceanographic Library
Naval Oceanographic Office
Stennis Space Center
NSTL, MS 39522-5001

Library
Institute of Ocean Sciences
P.O. Box 6000
Sidney, B.C. V8L 4B2
CANADA

Library
Institute of Oceanographic Sciences
Deacon Laboratory
Wormley, Godalming
Surrey GU8 5UB
UNITED KINGDOM

The Librarian
CSIRO Marine Laboratories
G.P.O. Box 1538
Hobart, Tasmania
AUSTRALIA 7001

Library
Proudman Oceanographic Laboratory
Bidston Observatory
Birkenhead
Merseyside L43 7 RA
UNITED KINGDOM

IFREMER
Centre de Brest
Service Documentation - Publications
BP 70 29280 PLOU
FRANCE

REPORT DOCUMENTATION PAGE	1. REPORT NO. WHOI-93-21	2.	3. Recipient's Accession No.
4. Title and Subtitle In Situ Measurements of the Dynamics of a Full Scale Bottom Moored Mine Model		5. Report Date June 1993	
7. Author(s) H.O. Berteaux, A. Bocconcelli, C. Eck and S. Kery		8. Performing Organization Rept. No. WHOI-93-21	
9. Performing Organization Name and Address Woods Hole Oceanographic Institution Woods Hole, Massachusetts 02543		10. Project/Task/Work Unit No.	
12. Sponsoring Organization Name and Address Naval Surface Warfare Center		11. Contract(C) or Grant(G) No. (C) (G)	
13. Type of Report & Period Covered Technical Report		14.	
15. Supplementary Notes This report should be cited as: Woods Hole Oceanog. Inst. Tech. Rept., WHOI-93-21.			
16. Abstract (Limit: 200 words) Under the sponsorship of the Naval Surface Warfare Center (NSWC), Dalgren Division, White Oak, Maryland, the Ocean Systems & Mooring Laboratory of the Woods Hole Oceanographic Institution devised (1991) and conducted (1992) an experiment to measure the dynamic response of a full scale model of the CAPTOR mine, submerged and moored in strong tidal currents near Woods Hole, MA. Specifically, the purpose of this sophisticated engineering experiment was to obtain long term, high frequency measurements of the spatial position of the CAPTOR body, of the tension at both ends of the mooring line, and of the mooring line strumming, as a function of the currents prevailing at the site. This report first describes the main components and the method of employment of the complex CAPTOR Dynamics Experiment (CAPTORDYN) set up. It then presents the mechanical and electrical designs of the entire system. Finally a review of the results obtained concludes the report.			
17. Document Analysis			
a. Descriptors moored mine dynamics buoy dynamics mooring dynamics			
b. Identifiers/Open-Ended Terms			
c. COSATI Field/Group			
18. Availability Statement Approved for public release; distribution unlimited.	19. Security Class (This Report) UNCLASSIFIED	21. No. of Pages 75	
	20. Security Class (This Page)	22. Price	