

1

TEC-0048

AD-A276 445



US Army Corps
of Engineers
Topographic
Engineering Center

Smart Environmental Monitor Based on Neural Networks and Multi-Spectral Pattern Recognition

S DTIC
ELECTE
MAR 03 1994 **D**
E

Taiwei Lu

Physical Optics Corporation
20600 Gramercy Place, Building 100
Torrance, CA 90501

September 1993

Approved for public release; distribution is unlimited.

U.S. Army Corps of Engineers
Topographic Engineering Center
7701 Telegraph Road
Alexandria, Virginia 22310-3864

T

E

C

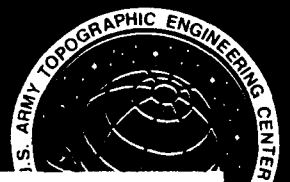

94-06865



**Destroy this report when no longer needed.
Do not return it to the originator.**

The findings in this report are not to be construed as an official Department of the Army position unless so designated by other authorized documents.

The citation in this report of trade names of commercially available products does not constitute official endorsement or approval of the use of such products.

DISCLAIMER NOTICE

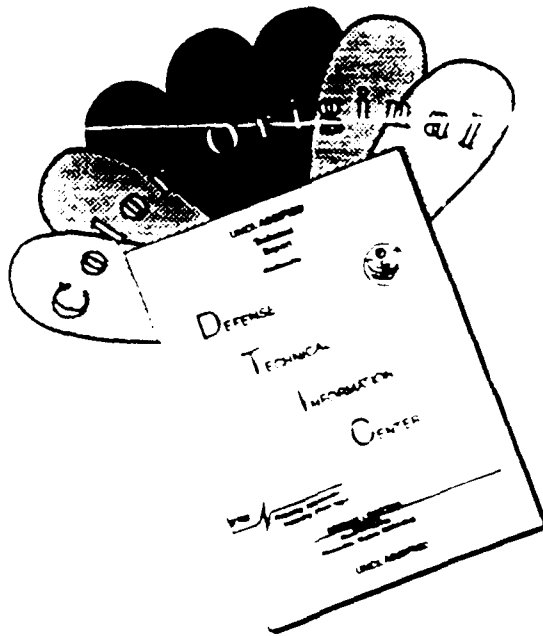

THIS DOCUMENT IS BEST QUALITY AVAILABLE. THE COPY FURNISHED TO DTIC CONTAINED A SIGNIFICANT NUMBER OF COLOR PAGES WHICH DO NOT REPRODUCE LEGIBLY ON BLACK AND WHITE MICROFICHE.

REPORT DOCUMENTATION PAGE

Form Approved
OMB No. 0704-0188

Public reporting burden for this collection of information is estimated to average 1 hour per response, including the time for reviewing instructions, searching existing data sources, gathering and maintaining the data needed, and completing and reviewing the collection of information. Send comments regarding this burden estimate or any other aspect of this collection of information, including suggestions for reducing this burden, to Washington Headquarters Services, Directorate for Information Operations and Reports, 1215 Jefferson Davis Highway, Suite 1204, Arlington, VA 22202-4302, and to the Office of Management and Budget, Paperwork Reduction Project (0704-0188), Washington, DC 20503.

1. AGENCY USE ONLY (Leave blank)	2. REPORT DATE September 1993	3. REPORT TYPE AND DATES COVERED Final Report March 1993 - September 1993	
4. TITLE AND SUBTITLE Smart Environmental Monitor Based on Neural Networks and Multi-Spectral Pattern Recognition		5. FUNDING NUMBERS DACA76-93-C-0004	
6. AUTHOR(S) Taiwei Lu			
7. PERFORMING ORGANIZATION NAME(S) AND ADDRESS(ES) Physical Optics Corporation 20600 Gramercy Place, Building 100 Torrance, CA 90501		8. PERFORMING ORGANIZATION REPORT NUMBER	
9. SPONSORING/MONITORING AGENCY NAME(S) AND ADDRESS(ES) U.S. Army Topographic Engineering Center 7701 Telegraph Road Alexandria, VA 22310-3864		10. SPONSORING/MONITORING AGENCY REPORT NUMBER TEC-0048	
11. SUPPLEMENTARY NOTES			
12a. DISTRIBUTION/AVAILABILITY STATEMENT Approved for public release; distribution is unlimited.		12b. DISTRIBUTION CODE	
13. ABSTRACT (Maximum 200 words) In Phase I of this project, Physical Optics Corporation (POC) accomplished the goal of the original proposal which was to develop and optimize a unique neural network (NN) algorithm that performs rapid spectral signal processing and identification. POC's NN algorithm was tested with extremely noisy Raman spectra from Lawrence Livermore National Laboratory and experimentally showed at least ten times better sensitivity and reliability than conventional spectral signal processing methods. POC built a portable demonstration system that integrated a spectrometer with POC's NN and successfully demonstrated real-time spectral signature identification operations. POC proposed, for Phase II implementation, a holographic optical neural network (HONN) system that is capable of rapid hyperspectral imaging through an acoustic-optic tunable filter (AOTF), real-time spectral feature identification, and mapping. The success of the Phase II project will make automatic and rapid hyperspectral image analysis and feature location possible. <p style="text-align: right;">DTIC QUALITY INSURED</p>			
14. SUBJECT TERMS Neural Networks, Holographic Optical Spectral Feature Identification, Portable Smart Spectrometer, Hyperspectral Image Processing			15. NUMBER OF PAGES 19
			16. PRICE CODE
17. SECURITY CLASSIFICATION OF REPORT UNCLASSIFIED	18. SECURITY CLASSIFICATION OF THIS PAGE UNCLASSIFIED	19. SECURITY CLASSIFICATION OF ABSTRACT UNCLASSIFIED	20. LIMITATION OF ABSTRACT UNLIMITED

TABLE OF CONTENTS

1.0	INTRODUCTION	1
2.0	SUMMARY OF PHASE I ACHIEVEMENTS.....	1
3.0	NEURAL NETWORK ALGORITHM FOR SPECTRAL SIGNAL PROCESSING.....	2
4.0	IDENTIFICATION OF CHEMICAL CONTAMINANTS IN RAMAN SPECTRA	5
5.0	DEVELOPMENT OF A DEMONSTRATION PORTABLE SMART SPECTROMETER .	8
6.0	HOLOGRAPHIC OPTICAL NEURAL NETWORK FOR HYPERSPECTRAL IMAGE PROCESSING	12
7.0	REFERENCES.....	14

Accession For	
NTIS CRA&I	<input checked="" type="checkbox"/>
DTIC TAB	<input type="checkbox"/>
Unannounced	<input type="checkbox"/>
Justification	
By	
Distribution /	
Availability Codes	
Dist	Avail and/or Special
A-1	

PREFACE

This report was prepared under Contract DACA76-93-C-0004 for the U.S. Army Topographic Engineering Center, Alexandria, Virginia 22310-3864 by Physical Optics Corporation, Torrance, California 90501. The Contracting Officer's Representative was Mr. Jim Shine.

1.0 INTRODUCTION

The goal of Phase I of this project was to investigate a neural-network-based smart environmental monitor (SEM) for multi-spectral pattern recognition. The Phase I project was to establish the system design and to experimentally demonstrate the feasibility of our approach. The objectives of Phase I were to:

1. Study existing architectures which use neural networks for multi-spectral pattern recognition.
2. Select an optimal system architecture for environmental monitoring applications and demonstrate a prototype of at least one such architecture.
3. Demonstrate the feasibility of the approach by training and testing this architecture prototype on a specific environmental application in a proof-of-concept experiment.

The goals and objectives of Phase I were successfully accomplished. The greatest amount of effort was directed toward developing an optimal neural network. This network is capable of acquiring and processing spectral characteristics obtained from a compact Raman and fluorescence spectrometer and can be used with any one-dimensional data set. Included in the software are the algorithms for network training for subsequent spectral recognition. Details of the Phase I experiments are presented in this report. A demonstration model of a portable smart spectrometer was constructed. Physical Optics Corporation (POC) has investigated the feasibility of using its existing technologies in optical and electronic neural networks and in software algorithms for hyperspectral image processing. A design concept for the Phase II implementation of a holographic optical neural network for high-speed hyperspectral image processing is presented in Section 6.

2.0 SUMMARY OF PHASE I ACHIEVEMENTS

In Phase I, POC

1. Developed a neural-network-based algorithm for spectral signal processing. The algorithm is capable of extracting spectral features and performing identification in real time. The neural network is user friendly, and is trained by sets of experimentally acquired data for known substances.

2. Cooperated with the Lawrence Livermore National Laboratory in the identification of chemical contaminants from Raman spectra. Preliminary experimental results have shown that POC's neural-network-based algorithm is sensitive to spectral features and robust to noise, even when the input spectrum is very noisy (signal-to-noise-ratio (SNR) less than 1:1).
3. Constructed a portable demonstration smart spectrometer. The system is capable of automatic acquisition of spectral signals and real-time spectral analysis and identification.
4. Conceptually designed a holographic optical neural network (HONN) architecture for high-speed 3-D hyperspectral image processing. The proposed HONN system will be implemented in the Phase II program.

The Phase I accomplishments are discussed in detail below.

3.0 NEURAL NETWORK ALGORITHM FOR SPECTRAL SIGNAL PROCESSING

Artificial neural networks are modeled after biological neural networks [1]. Neural networks consist of layers of processors (neurons) interconnected as shown in Figure 1. The data enters the system from the input neuron layer. Then the neural network performs a nonlinear transformation, producing a result represented by the status of the output neuron layer. Neural networks can be used in the transformation of complex spectral signature data (in the input neuron layer) into a meaningful output (in the output neuron layer) for automatic signal identification. The input neuron layer is subdivided into groups of neurons representing signals originating from different input sensors or feature windows resulting from pre-processing. The neurons in the output layer represent the likelihood that a given input belongs to a specific output class.

The processing concept of the neural network is based on a simple function that is executed by all of the neurons in each layer of the network. Each neuron receives input from the neurons of the preceding layer. A receiving neuron performs a weighted summation operation on all the inputs, compares this result with a predefined threshold, then generates an output using a nonlinear function, according to the following formula

$$y_j = F \left(\sum_{i=0}^N T_{ij} x_i - \theta_j \right) \quad (1)$$

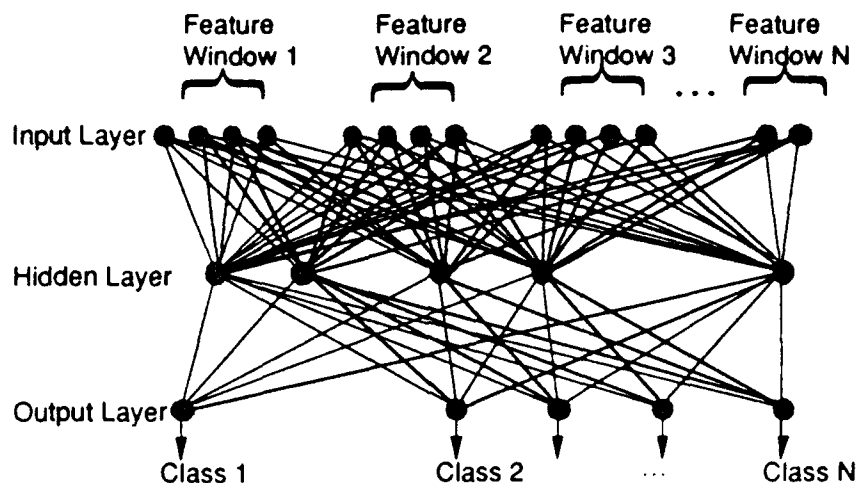

Figure 1
Schematic of the neural network concept.

where x_i ($i = 0, 1, \dots, N$) is the input to the j^{th} neuron, T_{ij} is the weight associated with input neuron x_i , q_j is the threshold value, and F is the non-linear function.

The neural network can learn from the training examples to associate different features from the input in order to reach an optimum output result. The adaptive learning, massive interconnection, and nonlinear classification capabilities of neural networks make them generally more robust to noise and distortion, and more sensitive to trained features for signal identification and classification than are conventional methods. Section 4.0 presents several examples where a neural network was used to identify spectral features.

In the Phase I project, POC developed a combination which uses pre-processing and a neural network algorithm for spectral signal identification, as illustrated in Figure 2. The spectral signals from the spectrometer are converted to a digital format via a CCD detector and a frame grabber. The spectra first go through a pre-processing stage in which smoothing, normalization, and windowed cross-correlation operations are performed. These signal processing techniques remove the thermal noise (via smoothing), eliminate background bias signals (via normalization), and enhance features of interest (via windowed cross-correlation).

The pre-processed signals are then sent to the next stage for neural network training and identification. The input neurons are grouped to represent the feature windows from the pre-processing stage. A set of training examples is used to train the neural network to produce correct responses from the output neurons such that only one output neuron responds high and the rest low for a certain chemical compound.

After training, the neural network is ready to perform recognition. When an unknown spectrum is input, the neural network immediately generates a confidence value for each output neuron. The confidence value is between 0 and 100%. In the post-processing stage, the user can define the desired thresholding value for proper recognition. Output values above the threshold will be recognized as positive identification, whereas output values below the threshold will be considered negative. For confirmation, a rerun maybe requested by the processor. For example, the threshold can be set at 50%. When the value of the output neuron representing Carbon Tetrachloride, for example, is 85%, then the system will conclude: "Carbon Tetrachloride is detected (with 85% confidence)."

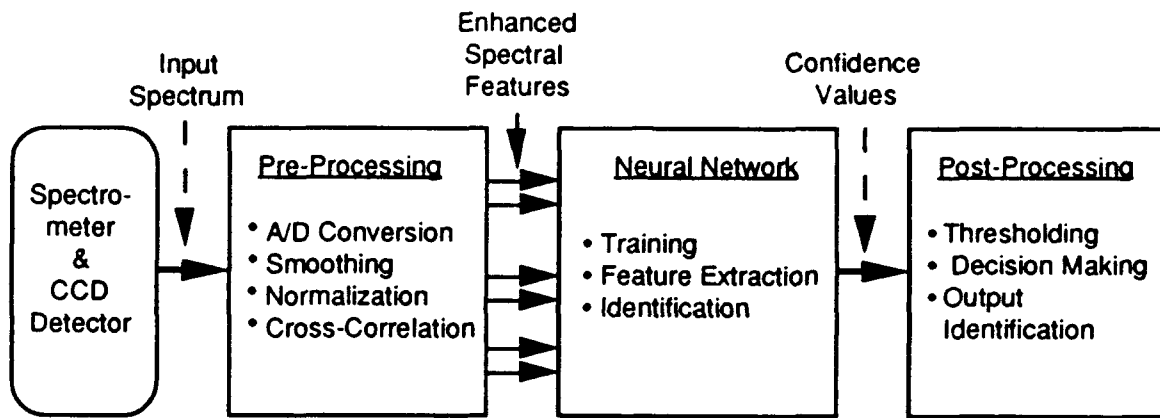

Figure 2
Schematic diagram of POC's neural-network-based spectral signal processing.

POC has developed a spectral signal processing algorithm that employs a windowed-correlation algorithm for spectral feature extraction and a three-layer neural network for spectral signature identification. The schematic diagram of the spectral signal processing algorithm is shown in Figure 3. The windowed correlator can be expressed as:

$$y(t) = \int_a^b x(\tau)h(t - \tau)d\tau \quad (2)$$

where $x(\tau)$ is the input spectrum, $h(\tau)$ is a reference function that contains certain unique features in the window region $[a,b]$, and $y(t)$ is the cross-correlation output.

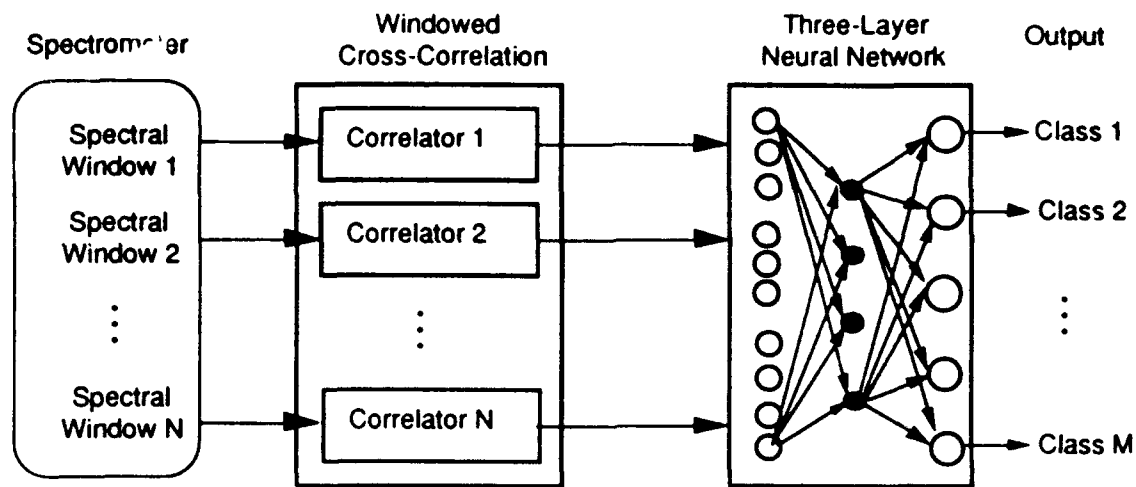

Figure 3
POC's spectral signal processing algorithm.

The windowed-cross-correlation function enables the spectral features in the training set to correlate with the input unknown spectrum. This pre-processing step can suppress the noise from the spectrum, thus enhancing the desired features in defined windows. The correlation output is then sent to a neural network for identification.

POC has developed a three-layer feed-forward neural network for spectral feature identification. The number of input neurons corresponds to the number of data points after the windowed-correlation operation, about 200 ~ 300 points from a 1024 point raw data set. Currently, the neural network has 200, 100, and 5 neurons in the input, hidden, and output layers, respectively. We used backpropagation training to train the network with spectra which have high SNR. The network can identify very low SNR (≤ 1) unknown spectra.

4.0 IDENTIFICATION OF CHEMICAL CONTAMINANTS IN RAMAN SPECTRA

POC has applied its spectral signal processing algorithms to the identification of Raman spectra. To validate the potential of POC's neural network technique to analyze and classify spectral signatures, POC teamed with a group at Lawrence Livermore National Laboratory (LLNL), directed by Dr. Kevin Kyle, to identify the presence of five chlorinated organic compounds,

carbon tetrachloride (CCl₄), chloroform (CHCl₃), dichloromethane (DCM), 1,1,1-trichloroethane (TCA), and 1,1,2-trichloroethylene (TCE), using their spectral signatures from a Raman spectrometer. LLNL provided us with a set of known "clean" spectra (i.e., high SNR input) from a Raman spectrometer as the training data set for our neural-network-based spectral identification technique. Spectral signatures for each organic compound were used as the training data sets. Figure 4(a) shows a clean spectrum of a mixture of the five compounds.

LLNL also provided us with a large number of spectra of mixtures of compounds taken in noisy environments. Five sets of spectra had SNR > 3:1, 10 had SNR ~ 2:1, 20 had SNR ~ 1.5:1, and 20 had SNR ≤ 1:1. The first three sets of spectra were used to train a three layer neural network, and the last set (SNR ≤ 1) was used to test the performance of the spectral identification simulator.

A multi-channel correlator was used to pre-process the input spectra. A correlator is an optimum filter that can separate the majority of noise from the desired signals. The signals are the characteristic peaks in the Raman spectrum that indicate the presence of certain chemical structures. In a Raman spectrum, two or three peaks can often be selected to represent one chemical compound. The rest of the spectrum contains no useful information about that chemical. We can drastically reduce the computational requirement for correlation operations by selecting only the proper correlation windows in the spectrum to cover the characteristic peaks.

In our particular experiment, thirteen windows were chosen -- three windows each for CCl₄, CHCl₃, TCE, and TCA, and one window for CH₂Cl₂.

Our task was to classify these unknown, noisy spectra. The spectra were of pure individual organic compounds, a random mixture of the four or five compounds, or pure noise. Figure 4(b) shows one such noisy spectra. The objective of this classification exercise was to verify the robustness and adaptability of our neural network technique. POC did not know in advance the identity of the noisy input spectra. We achieved an overall successful classification rate >90%. The results are summarized in Table 1. Notice that if three consecutive frames of signals are co-added, the identification rate for SNR < 1:1 is almost 100%!

Smart Spectrometer

REAL TIME Detection of Halogenated Hydrocarbons

(a)

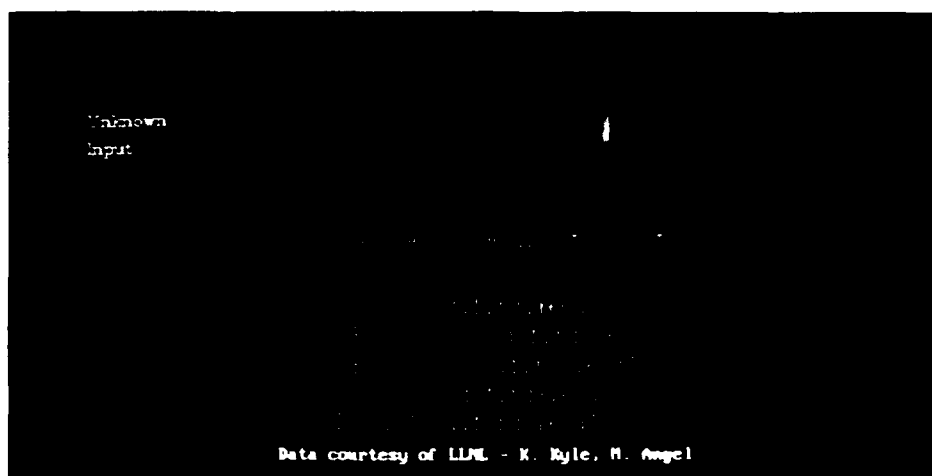

(b)

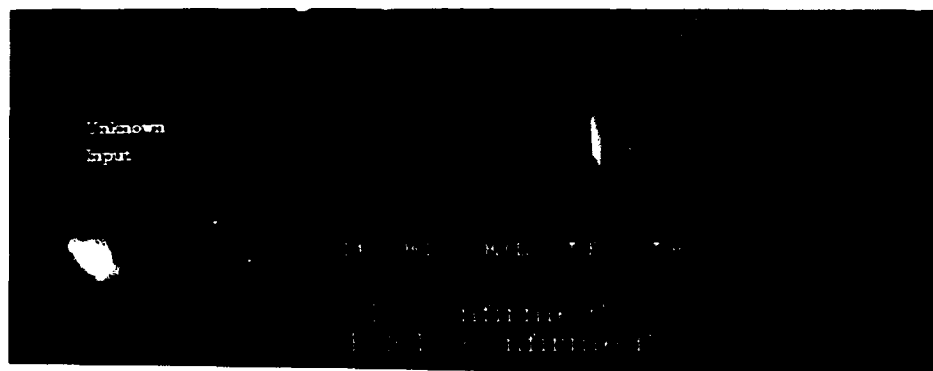

(c)

Figure 4
Examples of the identification of Raman spectra:
(a) "clean" spectrum of a mixture of five chemical compounds, and
(b) rapid identification of the presence of five compounds in a noisy environment (SNR = 1:1),
(c) rapid identification of the presence of CCL4 and CH2Cl2 with SNR < 1:1.

Table 1 Experimental Results of Sample Identification by POC's Neural-Net-Based Smart Spectrometer

Sample	CCl ₄	CHCl ₃	CH ₂ Cl ₂	TCE	TCA	4-Mix	5-Mix
Input SNR	Correct ID/NR	Correct ID/NR	Correct ID/NR	Correct ID/NR	Correct ID/NR	Correct ID	Correct ID
SNR > 5:1	Data Used for Training					100%	100%
SNR = 2:1						100%	100%
SNR = 1:1						100%	99%
SNR < 1:1	90% 95%	100% 83%	100% 100%	100% 95%	100% 95%	77%	78%
SNR < 1:1* (Three-Frame)	100% 100%	—	—	—	—	100%	93%

* Three frames of input patterns are added before presentation to the identification neural network algorithm.

CCl ₄ :	Carbon Tetrachloride	5-Mix :	Mixture of all of above
CHCl ₃ :	Chloroform	4-Mix :	Mixture of all of above except TCE
CH ₂ Cl ₂ :	Dichloromethane	ID:	Identification
TCE :	Trichloroethylene	NR:	Noise Rejection
TCA :	1, 1, 1-Trichloroethane		

Source of Data: LLNL Raman Spectral Data Set (Courtesy of Kevin Kyle and Michael Angel)

5.0 DEVELOPMENT OF A DEMONSTRATION PORTABLE SMART SPECTROMETER

POC has completed the development of a preliminary demonstration model of a neural-network-based smart spectrometer.

A schematic diagram of the smart spectrometer is shown in Figure 5. The system consists of a laser diode (wavelength = 670 nm, power = 10 mW) as the excitation light source, a fiber probe to deliver the laser light to the sample and to collect the return light from the sample and carry it to the spectrometer (Instruments SA, Model CP140, 140 mm focal length spectrograph). A CCD camera (a Sony video camera) is used to convert the light intensity of the spectrum into an electrical signal, and a frame grabber (Matrox, Model IP-8) converts the analog signal into digital form. A notebook computer runs software routines that control and synchronize the system operations. The neural network algorithm performs real-time spectral signature extraction and identification.

The frame grabber and neural network processor boards can be inserted in a docking station interfaced to the notebook computer.

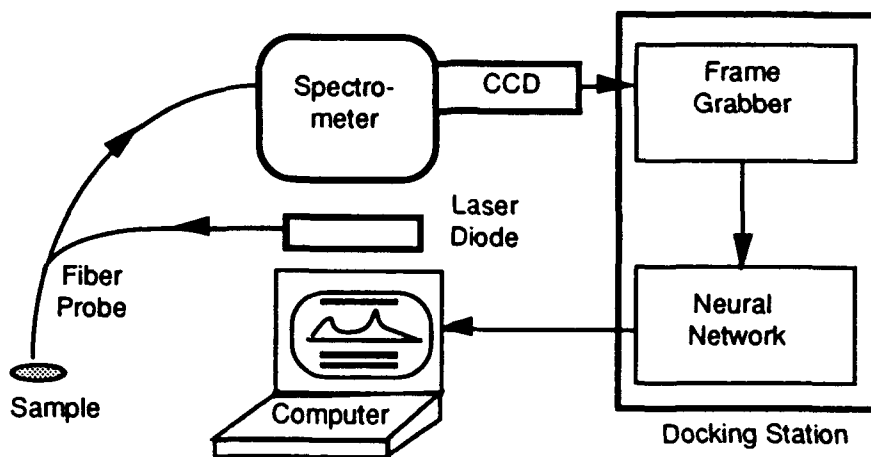

Figure 5
Schematic diagram of POC's smart spectrometer.

POC has designed a fiber probe specifically for the smart spectrometer, as shown in Figure 6. A single fiber (400 μm diameter) delivers the laser excitation light to the sample. Then a bundle of small fibers (100 μm diameter) collects the return light from the sample and carries it to the spectrometer. The spectrometer end of the fiber bundle is shaped in a line for maximum throughput.

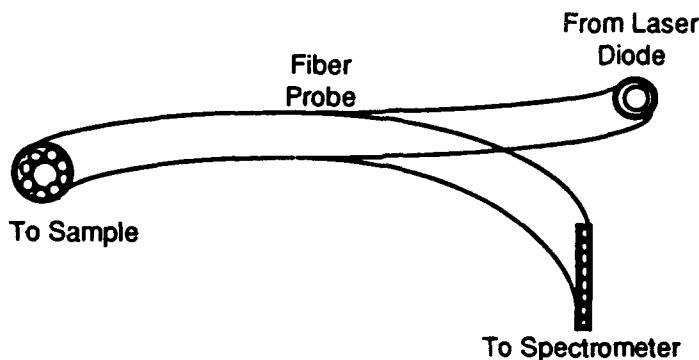

Figure 6
Structure of the fiber probe.

The smart spectrometer is contained in a briefcase, as shown in Figure 7. A notebook computer with a docking station (containing the frame grabber) sits on top of the briefcase. The computer can be put into the briefcase to be carried easily. The size of the system is 16 x 18 x 7 cubic inches. The weight of the system is about 20 lbs.

Figure 8 shows the system in action. The output of the smart spectrometer is displayed on a regular super VGA monitor so that we could photograph it clearly for this report. In this demonstration, we trained the system to recognize a fluorescent light, a Tungsten light, a laser source, a green LED, and a fluorescing liquid sample. Other light sources are classified as Unknown. The neural network takes less than three minutes to learn a set of 20 training examples on the notebook computer. Then the system is ready for recognition operations. When the fiber probe is pointed at an object and a key is pressed, the system instantly displays the name of the object and a confidence level between 0 to 100%. The operator can set a threshold value for the minimum and the maximum confidence levels for recognition. For example, the threshold can be set as low as 30% of the confidence level so that no important object is missed, or the threshold can be set between 70% and 90% of the confidence level so that no false alarms will occur.

The demo system uses off-the-shelf components, a simple mechanical design, and a software program on a notebook computer. The system can be designed to be more compact, more versatile and more powerful by using parallel digital signal processors (DSPs) and holographic optical neural networks (HONNs). The design for the Phase II implementation of a high-speed parallel hyperspectral image analyzer is presented in the next section.

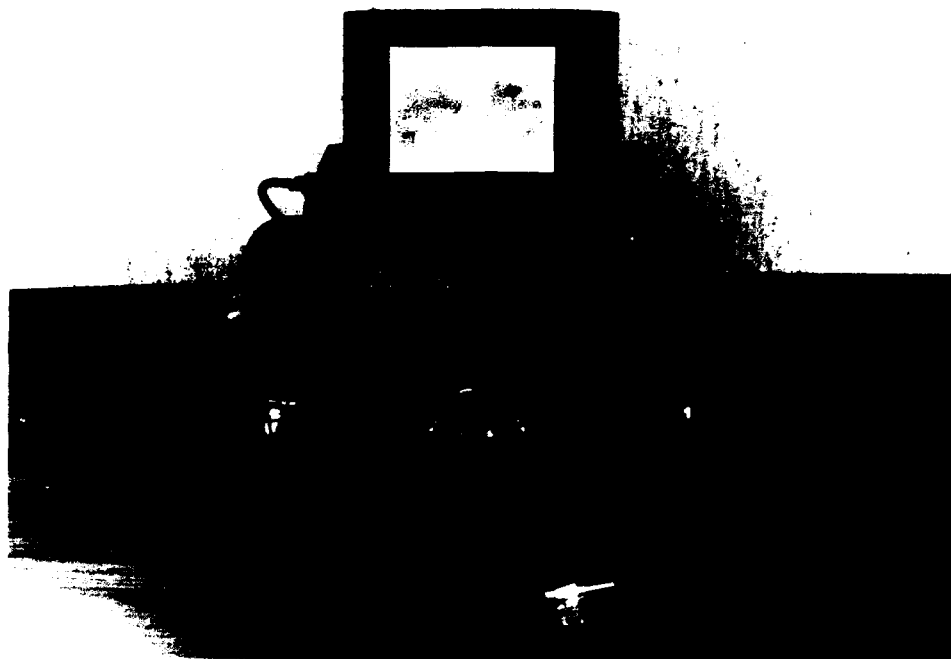

Figure 7
POC's portable smart spectrometer.



Figure 8
POC's smart spectrometer in action.

6.0 HOLOGRAPHIC OPTICAL NEURAL NETWORK FOR HYPER SPECTRAL IMAGE PROCESSING

So far, we have been dealing with 1-D spectral signals. The total volume of data is usually around 1,000 data points, approximately one to ten kBytes. Software and DSP hardware can be used to perform real-time analysis on this small data set. However, in dealing with hyperspectral images [2], i.e., 3-D data representations, the volume of data to be analyzed is extremely large. For example, a hyperspectral image of 1000 x 1000 pixels has a wavelength range of 400 to 2400 nm, with a spectral resolution of 10 nm and dynamic range of 10^5 . The total volume of data is as high as 10^9 Bytes. A parallel processing system is needed for the real-time processing of each hyperspectral image. Based on many years of experience in the applications of advanced holographic optical neural network (HONN) technology to pattern recognition [3-9], POC proposes to use HONN technology for high-speed hyperspectral image processing.

POC is aware that hyperspectral image processing has considerable commercial potential. Dr. N. Lewis and his research team at NIH are presently working on "real-time" imaging by IR and Raman radiation of live tissue samples. These signals are wavelength tuned with an acousto-optic tunable filter (AOTF), but the problem of rapid and cost effective data processing has not yet been solved [10,11].

The proposed HONN system is illustrated in Figure 9(a). It includes a spectral imaging device, for example, an AOTF for very fast wavelength selection. A multiple wavelength image sequence (see Figure 9(b)) is monitored by a detector array, such as a CCD camera, and stored in an image buffer memory. An acousto-optic (AO) device is used as a 1-D input spatial light modulator to display the spectral content of each pixel of the image, as shown in Figure 9(c). A cylindrical lens expands the input waveform vertically to illuminate an array of holograms. A set of spectral features (see Figure 9(d)) which represents a library of different chemical components has been recorded in each slice of the hologram array. When the library is small, the spectral feature set can be generated manually. However, neural network training provides a versatile method for optimum feature extraction for the generation of a large feature library. If the input spectrum matches the stored feature vector, then the hologram generates a strong correlation signal on the output detector array. The intensity of the peak tells the degree of correlation between the input unknown signal and the stored feature vector. The location of the correlation peak indicates which species has been detected. As a result, the proposed architecture shown in Figure 9(a) performs high-speed operations to correlate an input signal with a library of reference features in parallel in a few microseconds. A detailed discussion of the HONN system proposed for development in Phase II will be included in the Phase II proposal.

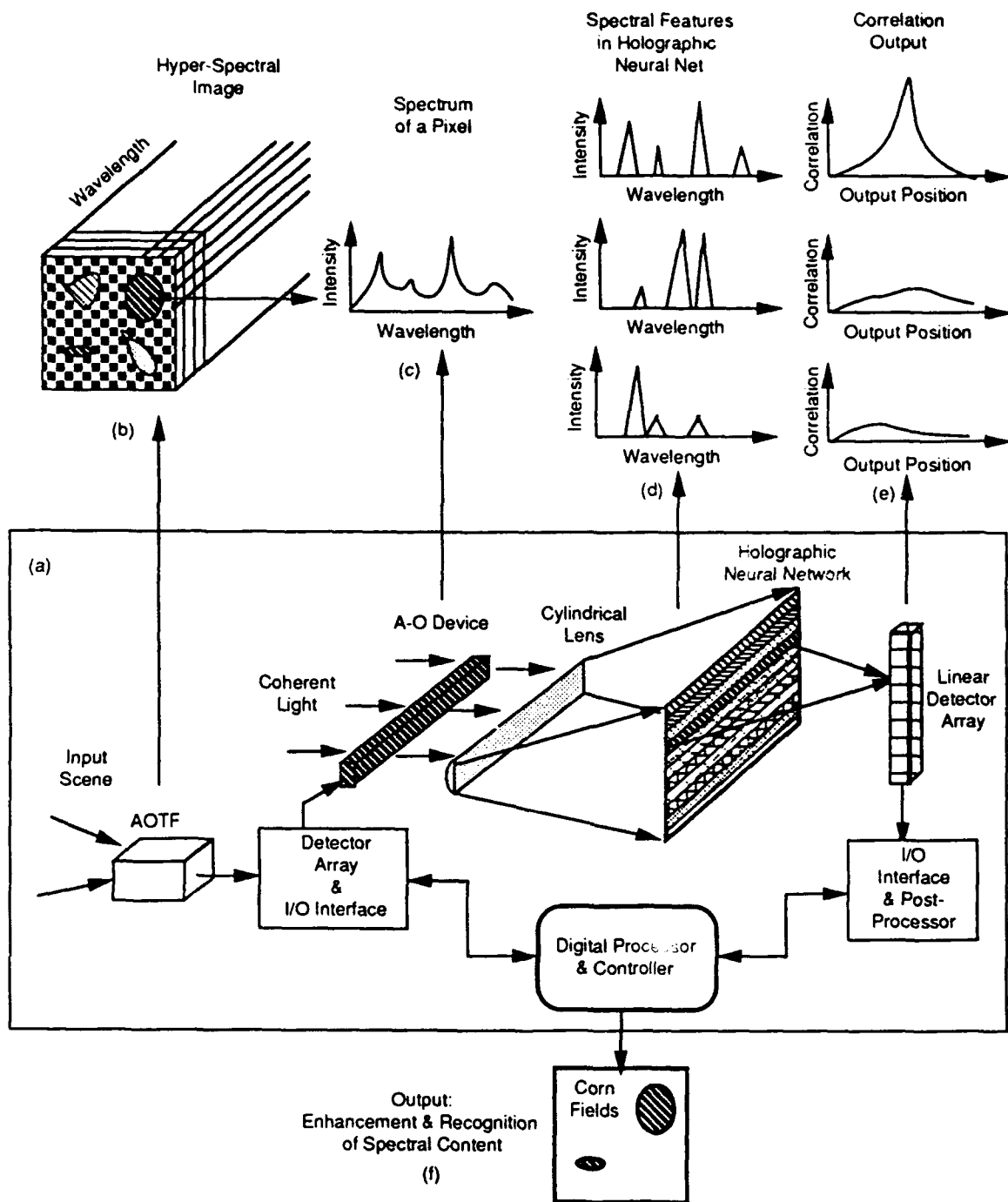

Figure 9
A HONN system for parallel spectral signal processing.

7.0 REFERENCES

1. R. P. Lippmann, "An Introduction to Computing with Neural Nets," IEEE ASSP Mag. pp. 4-22 (1987).
2. J. N. Rinker, "Remote Sensing Tutorial: Multiband, Multispectral, Hyperspectral," Tutorial Report, U.S. Army Topographic Engineering Center (Nov. 1992).
3. J. M. Lerner and T. Lu, "Practical Neural Nets for Spectroscopic Analysis," Photonics Spectra Magazine (Aug. 1993).
4. T. Lu, A. Kostrzewski, H. Chou, S. Wu, and F. Lin, "Performance Evaluation of a Holographic Optical Neural Network (HONN) System," SPIE Proceedings, 1773A-05, San Diego (1992).
5. T. Lu, and F. Lin, "Experimental Demonstration of Large Scale Holographic Optical Neural Network," International Joint Conference on Neural Networks, Vol. 1, pp. 353, Seattle (1991).
6. T. Lu, X. Xu, S. Wu, and F. T. S. Yu, "Neural Network Model Using Interpattern Association," Applied Optics, 29, 2, 284 (1990).
7. T. Lu, F. T. S. Yu, and D. A. Gregory, "Self-Organizing Optical Neural Network for Unsupervised Learning," Optical Eng., 29, 9, 1107 (1990).
8. F. T. S. Yu, T. Lu, X. Yang, and D.A. Gregory, "Optical Neural Network with Pocket-Sized Liquid Crystal Televisions," Optical Lett., 15, 15, 865 (1990).
9. T. Lu, S. Wu, X. Xu, and F. T. S. Yu, "Two-Dimensional Programmable Optical Neural Network," Applied Optics, 28, 22, 4908 (1989).
10. P. J. Treado, I. W. Levin, and E. N. Lewis, "High Fidelity Raman imaging Spectrometry: A Rapid Method Using an acousto-optic Tunable Filter," Applied Spectroscopy, 46, 1211 (1992).
11. P. J. Treado, I. W. Levin, and E. N. Lewis, "Near-Infrared Acousto-Optic Spectroscopic Microscopy: A Solid-State Approach to Chemical Imaging," Applied Spectroscopy, 46, 553 (1992).