

2

NAVAL POSTGRADUATE SCHOOL Monterey, California

AD-A276 058



DTIC
FEB 23 1984
C U

THESIS

*A REAL-TIME U.S. ARMY TACTICAL TELEPHONE
NETWORK MANAGEMENT SYSTEM*

by

Gregory Morris Johnson

September 1993

Thesis Advisor:

Dr. G. M. Lundy

Approved for public release; distribution is unlimited

3228

94-06455



DTIC (U) UNCLASSIFIED

94 2 25 170

**Best
Available
Copy**

REPORT DOCUMENTATION PAGEForm Approved
OMB No. 0704-0188

Public reporting burden for this collection of information is estimated to average 1 hour per response, including the time reviewing instructions, searching existing data sources, gathering and maintaining the data needed, and completing and reviewing the collection of information. Send comments regarding this burden estimate or any other aspect of this collection of information, including suggestions for reducing this burden to Washington Headquarters Services, Directorate for Information Operations and Reports, 1215 Jefferson Davis Highway, Suite 1204, Arlington, VA 22202-4302, and to the Office of Management and Budget, Paperwork Reduction Project (0704-0188), Washington, DC 20503.

1. AGENCY USE ONLY (Leave Blank)		2. REPORT DATE September 1993	3. REPORT TYPE AND DATES COVERED Master's Thesis	
4. TITLE AND SUBTITLE A Real-Time U.S. Army Tactical Telephone Network Management System (U)			5. FUNDING NUMBERS	
6. AUTHOR(S) Johnson, Gregory Morris			8. PERFORMING ORGANIZATION REPORT NUMBER	
7. PERFORMING ORGANIZATION NAME(S) AND ADDRESS(ES) Naval Postgraduate School Monterey, CA 93943-5000			10. SPONSORING/ MONITORING AGENCY REPORT NUMBER	
9. SPONSORING/ MONITORING AGENCY NAME(S) AND ADDRESS(ES)			10. SPONSORING/ MONITORING AGENCY REPORT NUMBER	
11. SUPPLEMENTARY NOTES The views expressed in this thesis are those of the author and do not reflect the official policy or position of the Department of Defense or the United States Government.				
12a. DISTRIBUTION / AVAILABILITY STATEMENT Approved for public release; distribution is unlimited			12b. DISTRIBUTION CODE	
13. ABSTRACT (Maximum 200 words) The U.S. Army is currently developing a network management system for theater-level communications called the Integrated System Control. One limitation of this system is the lack of a real-time telephone network monitoring capability. Without this capability, communication commanders will not have a rapid and efficient tool for identifying and diagnosing network outages. The current semi-manual network reporting procedures are slow and error prone. This approach implements a real-time software monitoring system which displays the telephone network's status to the operator. This system allows the operator to locate and diagnose network outages in real-time. The result is an Ada program which receives line-of-sight radio shelter status messages and displays their effects on the network's status. The telephone network is represented by a series of display panels. Each panel provides the user with a different level of network detail, i.e., the network level, nodal level, internodal level, or line-of-sight radio shelter component level. The network's objects (line-of-sight radio shelters, circuit switches, telephone multiplexers, and radio and cable links) are represented by individual display objects. A color scheme is used to indicate a display object's status. This program is tested by simulating status messages via randomly reading a file.				
14. SUBJECT TERMS Area Common User System, Digital Group Multiplex, Integrated System Control, Mobile Subscriber Equipment, Wide Area Network Management			15. NUMBER OF PAGES 83	
			16. PRICE CODE	
17. SECURITY CLASSIFICATION OF REPORT Unclassified	18. SECURITY CLASSIFICATION OF THIS PAGE Unclassified	19. SECURITY CLASSIFICATION OF ABSTRACT Unclassified	20. LIMITATION OF ABSTRACT Unlimited	

Approved for public release; distribution is unlimited

**A REAL-TIME U.S. ARMY TACTICAL TELEPHONE NETWORK
MANAGEMENT SYSTEM**

by
Gregory Morris Johnson
Captain, United States Army
B. S., Florida Agricultural and Mechanical University, 1984

Submitted in partial fulfillment of the
requirements for the degree of

MASTER OF SCIENCE IN COMPUTER SCIENCE

from the

NAVAL POSTGRADUATE SCHOOL

September 1993

Author:

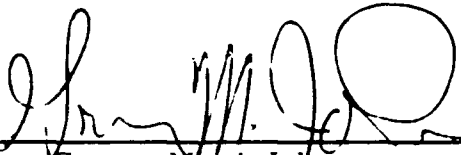

Gregory Morris Johnson

Approved By:

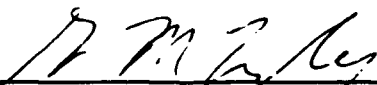

Professor G. M. Lundy, Thesis Advisor



LCDR John A. Daley, USN, Second Reader



*Dr. Ted Lewis, Chairman,
Department of Computer Science*

ABSTRACT

The U.S. Army is currently developing a network management system for theater-level communications called the Integrated System Control. One limitation of this system is the lack of a real-time telephone network monitoring capability. Without this capability, communication commanders will not have a rapid and efficient tool for identifying and diagnosing network outages. The current semi-manual network reporting procedures are slow and error prone.

This approach implements a real-time software monitoring system which displays the telephone network's status to the operator. This system allows the operator to locate and diagnose network outages in real-time.

The result is an Ada program which receives line-of-sight radio shelter status messages and displays their effects on the network's status. The telephone network is represented by a series of display panels. Each panel provides the user with a different level of network detail, i.e., the network level, nodal level, internodal level, or line-of-sight radio shelter component level. The network's objects (line-of-sight radio shelters, circuit switches, telephone multiplexers, and radio and cable links) are represented by individual display objects. A color scheme is used to indicate a display object's status. This program is tested by simulating status messages via randomly reading a file.

Accession For	
NTIS CRA&I	<input checked="" type="checkbox"/>
DTIC TAB	<input type="checkbox"/>
Unannounced	<input type="checkbox"/>
Justification	
By	
Distribution/	
Availability Codes	
Dist	Avail and/or Special
A-1	

TABLE OF CONTENTS

I.	INTRODUCTION.....	1
A.	THESIS MOTIVATION.....	1
B.	FOCUS OF THESIS.....	1
C.	AREA COMMON USER SYSTEM OVERVIEW.....	3
1.	Theater Level Communications.....	3
2.	Description of the Area Common User System.....	4
II.	NETWORK MANAGEMENT SYSTEM REQUIREMENTS.....	8
A.	NETWORK MANAGEMENT DEFINITIONS.....	8
B.	MANAGEMENT SYSTEM IMPLEMENTATION REQUIREMENTS.....	9
C.	TACTICAL TELEPHONE NETWORK MODEL.....	9
D.	TACTICAL TELEPHONE SYSTEM OVERVIEW.....	13
E.	MANAGEMENT SYSTEM REACTION REQUIREMENTS.....	20
1.	Background Information.....	20
2.	Network Reaction Requirements.....	21
III.	NETWORK MANAGEMENT SYSTEM DESIGN.....	29
A.	NETWORK MANAGEMENT SYSTEM OVERVIEW.....	29
B.	PANEL DESIGN SEGMENT.....	30
1.	Transportable Applications Environment Plus General Information ..	30
2.	Network Panel Designs.....	31
C.	TRC-173 STATUS MESSAGE SEGMENT DESIGN.....	33
1.	Network Model Database Design.....	34
2.	TRC-173 Status Message Status Message Structure.....	37
3.	TRC-173 Status Message Processing Logic Design.....	37
D.	SYSTEM MANAGEMENT CONTROLLER SEGMENT DESIGN.....	37
1.	Panel Display Object Database Design.....	37
2.	Network Database Processor Task.....	40
3.	Display Object Database Processor Task.....	40
4.	TRC-173 Status Message Receiver Task.....	42
5.	Display Object Timer Task.....	42
IV.	MANAGEMENT SYSTEM VALIDATION TEST.....	43
A.	MANAGEMENT SYSTEM VALIDATION TEST PROCEDURE.....	43
1.	Step 1: Constructing and Evaluating TRC-173 Data Set.....	43
2.	Step 2: Processing The Data Sets and Collecting The Results.....	44
3.	Step 3: Comparing The Predicted Against Actual Results.....	44
B.	SUMMARY OF TEST RESULTS.....	44
V.	CONCLUSIONS AND RECOMMENDATIONS.....	46
A.	CONCLUSIONS.....	46
B.	RECOMMENDATIONS FOR FURTHER RESEARCH.....	46
	APPENDIX A: ACRONYMS AND DEFINITIONS.....	48
	APPENDIX B: NETWORK LAYOUT & INTERNAL CONNECTIVITY.....	50
	APPENDIX C: ALGORITHMS FOR MESSAGE PROCESSING.....	60

APPENDIX D: MANAGEMENT SYSTEM FLOW DIAGRAMS	70
REFERENCES	74
INITIAL DISTRIBUTION LIST	76

I. INTRODUCTION

A. THESIS MOTIVATION

In the early 1970's, the U.S. Army started a program to modernize its tactical communications assets. The communication upgrades included a transition from analog to secure digital voice and data communications systems and the development of position location systems. Today these improvements have provided battlefield commanders with efficient and reliable tactical communications systems.

However, the one major drawback to these tactical communications advancements is that an equally advanced communications management system was not concurrently developed. Today communication commanders have no single automated system to assist them in communications management. These commanders are reduced to having their staffs compile the overall system status from separate communication management facilities. This semi-manual overall system status procedure is slow, inefficient, and error prone.

The U.S. Army is currently developing the Integrated System Control to manage all tactical communications systems. The system will automate the functions of wide area network management, network planning and engineering, battlefield frequency management, communications security management, and communication asset command control for the three classes of communications systems. TABLE 1 contains the communication classes and their functions.[Ref. 1]

The Integrated System Control wide area network management requirements do not address the issue of real-time tactical telephone network system monitoring. Without this capability, communication commanders will not have a rapid and efficient tool for identifying and diagnosing network outages.

B. FOCUS OF THESIS

The focus of this research is to design and implement an automated real-time Army Tactical Telephone Network Management System for a part of the communications

TABLE 1: ARMY COMMUNICATION CLASSES

Communication Class	Provides User With
Area Common User System	Battlefield telephone system
Combat Net Radio	Secure single channel communications
Army Data Distribution System	Communications for tactical data systems

network, known as the Area Common User System. This is a computer program which will illustrate that from a central location a user can monitor a tactical telephone network. The user can identify the cause of a status change by transversing through display panels.

The Army Tactical Telephone Network Management System monitors a fixed network consisting of line-of-sight radio shelters, circuit switches, telephone multiplexers, and cable and radio links. The management system updates the network's status color display when a status message is received. Line-of-sight radio shelters are the only objects in the system that will generate status messages.

This network management system is panel-driven and is divided into the following levels: network, nodal, internodal, and line-of-sight component. Each display panel consists of various display objects that graphically represents the network at different levels of detail.

The Ada programming language is utilized to implement the Army Tactical Telephone Network Management System. The Transportable Applications Environment Plus graphical user interface tool is used to produce the network panels. Validation testing

is used to demonstrate that the management system conforms with the system requirements.

C. AREA COMMON USER SYSTEM OVERVIEW

This section explains what the Area Common User System is, and describes its role in theater level communications.

1. Theater Level Communications

A theater is a geographical area that is outside of the Continental United States which has been assigned a unified or specified military commander. The geographic size of a theater can easily exceed 1,000,000 square km. Figure 1 depicts the portion of the Middle East that comprises the U.S. Central Command Theater. When U.S. military power is required the theater assets are geographically focused against the opposing force. The theater is divided into two levels: echelons corps and below and echelons above corps (see Figure 2). The echelons corps and below portion of the theater is where the actual combat operations are conducted and is composed of divisions and corps. A division is the most forward combat element (between the a division and corps) and consists of approximately 15,000 troops. The area that a division can cover is approximately 4000 square km. A corps generally contains from three to five divisions and its command structure and support elements operate behind the division areas. A corps, including its divisions, can contain more than 80,000 troops and operates in an area of 35,000 square km. The echelons above corps portion of the theater is the area rearward of combat operations and provides support for the entire theater. Some of the operations performed at the echelons above corps level include engineer, supply, communications, medical, and maintenance operations. Both of these levels perform their activities in support of the theater commander.[Ref. 2] & [Ref. 3]

Theater management is divided by the Army Command and Control System at the echelons above corps level and the Army Tactical Command and Control System at the echelons corps and below level. Both systems are integrated to support the five Battlefield Functional Areas: Maneuver Control, Air Defense, Fire Support, Intelligence, and Combat

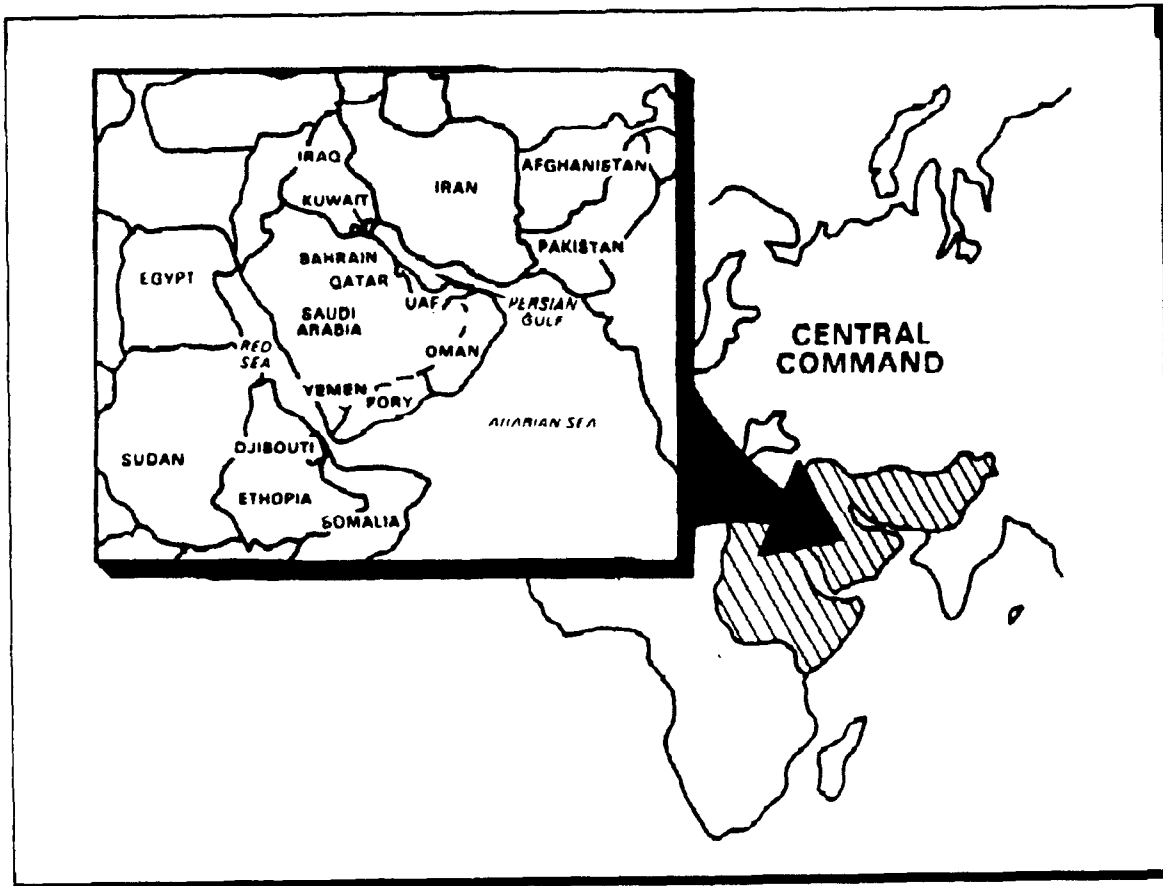

Figure 1: U.S. Central Command Theater

Service Support. By having these two systems interfaced together through the three communication classes (Area Common User System, Combat Net Radio, and Army Data Distribution System), critical information can be provided throughout theater (see Figure 3).[Ref. 2]

2. Description of the Area Common User System

The Area Common User System is a command and control system which is primarily a battlefield telephone system. Communication is provided over a geographical area by a combination of line-of-sight radio, tactical satellite, tropospheric scatter radio and cable links. Tropospheric scatter radio links use the earth's troposphere to reflect the transmitting radio's waves back to a receiving radio. This process creates a radio link of

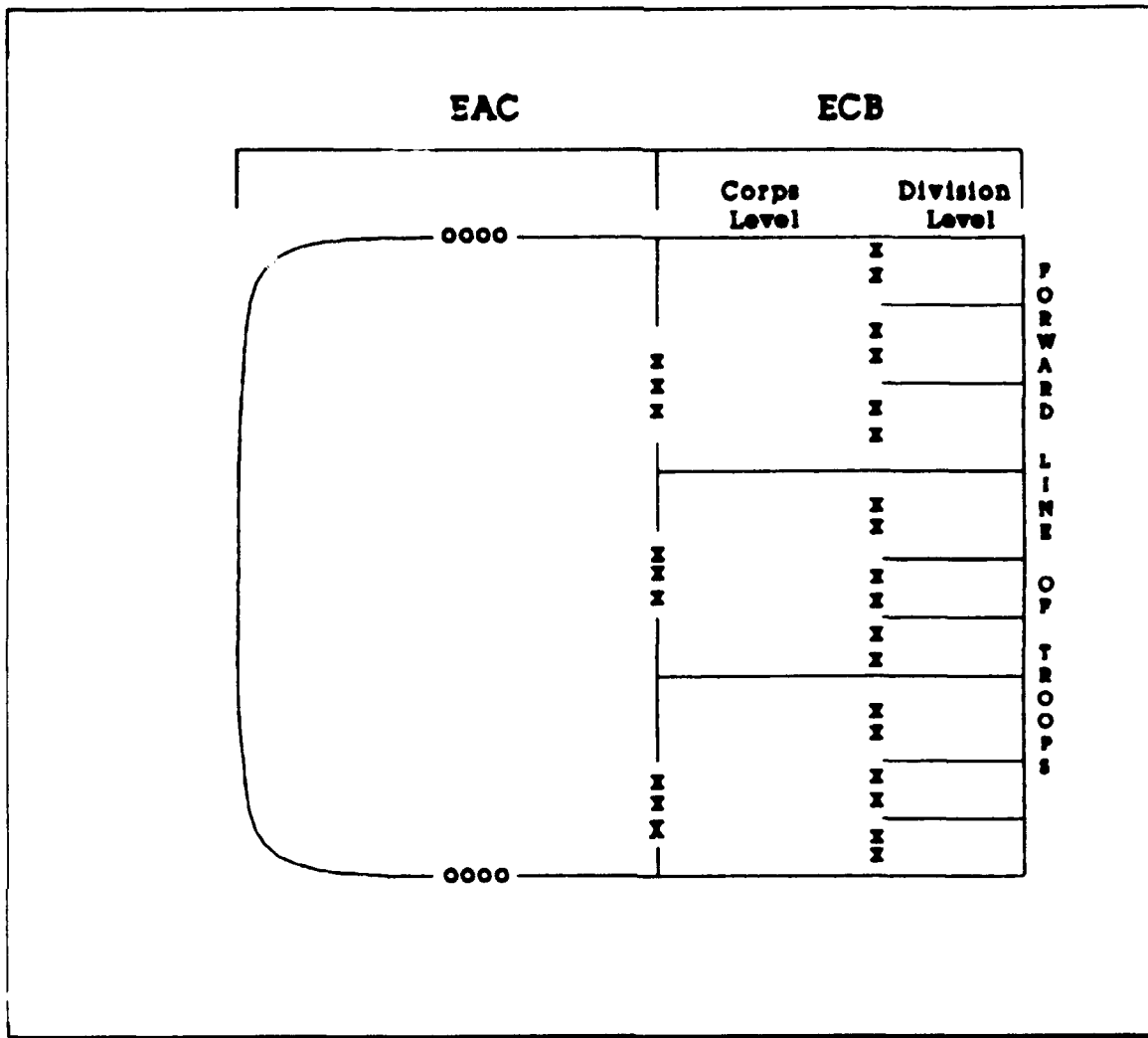

Figure 2: Theater Levels

270 km. Line-of-sight radio links are the primary mode of establishing network connectivity between circuit switches. When network connectivity requirements exceed the range of the line-of-sight radios (planning range 40 km) and the use of multiple relay stations are not economical, tactical satellite or tropospheric scatter links can be employed. In this thesis the reader only needs to know that tactical satellite and tropospheric scatter communication does exist in the Area Common User System. Cable links are used primarily to provide individual subscribers with telephone access to the tactical telephone network.[Ref. 4]

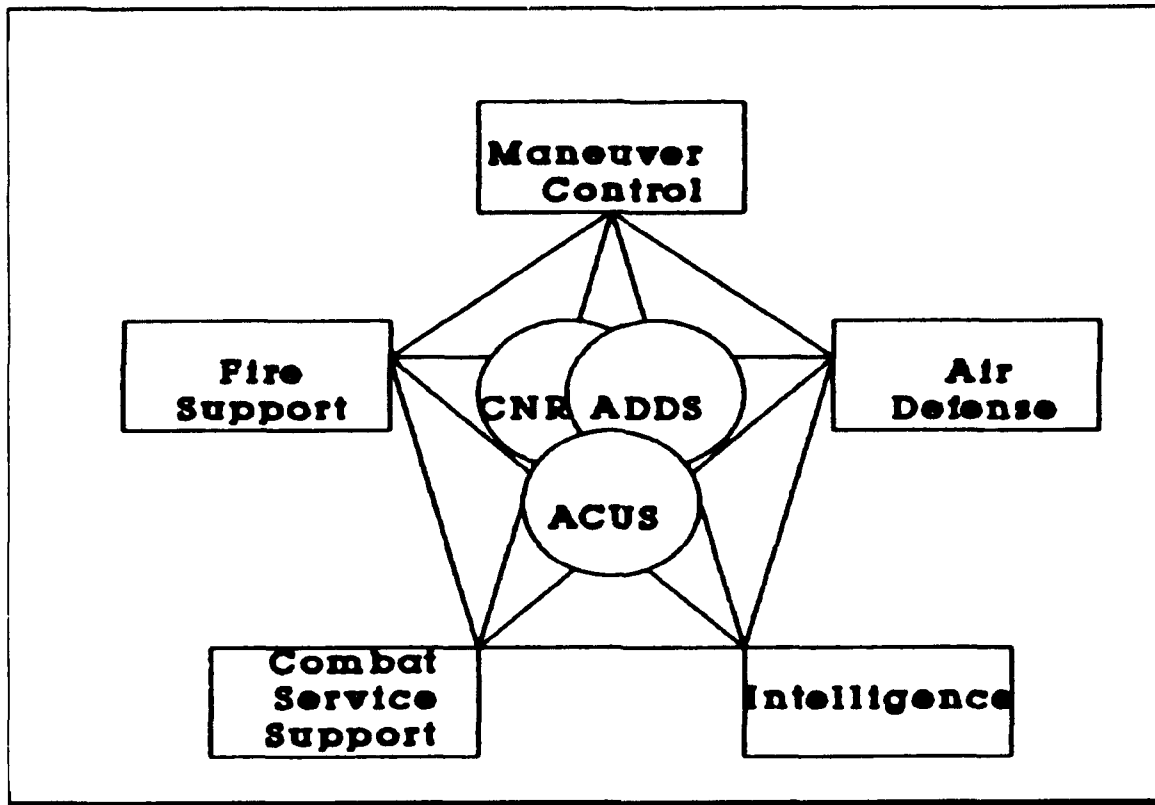

Figure 3: Command and Control System

The Area Common User System is divided into two subsystems - one that supports echelons above corps units and one that supports echelons corps and below units. The Echelons Above Corps Area Common User Subsystem is supported by Digital Group Multiplex equipment and by the AN/TTC-39 series circuit switch while the Echelons Corps and Below Area Common User Subsystem is supported by Mobile Subscriber Equipment. The main differences between the two subsystems are the channel kbps rate, circuit routing strategies, mobile subscriber support, and *International Consultative Committee on Telegraphy and Telephony* (CCITT) X.25 packet switching service. Digital Group Multiplex equipment and the AN/TTC-39 series circuit switch operate at 32 kbps (but can also operate at 16 kbps) per channel while Mobile Subscriber Equipment operates at 16 kbps. The AN/TTC-39 series circuit switch utilizes deterministic routing while Mobile Subscriber Equipment circuit switches use flood search routing. Flood search routing is a technique that requires a circuit switch to try all possible routes to complete a telephone

call. This routing technique ensures that the shortest communication path is utilized. Mobile Subscriber Equipment provides a tactical cellular telephone capability to mobile subscribers through the *Radio Access Unit (RAU)* and *Mobile Subscriber Radiotelephone Terminal (MSRT)*. This cellular telephone service is not provided by the Echelons Above Corps Area Common User Subsystem. CCITT X.25 package switching is available through the Mobile Subscriber Equipment circuit switches but not by the AN/TTC-39 series circuit switch. In order to integrate the two subsystems selected gateway circuit switches must be established.[Ref. 4], [Ref. 5] & [Ref. 6]

In the near future, echelons above corps communications will be more comparable to echelons corps and below communications. For example, the AN/TTC-39 series circuit switch will be enhanced to include flood search routing [Ref. 5]. This will ensure that the most efficient route through the network will always be utilized. It will also enable direct echelons above corps switch to echelons corps and below switch trunking without designating gateway switches between the two levels. Other enhancements to the echelons above corps level will be a tactical cellular telephone capability and CCITT X.25 packet switching [Ref. 7] & [Ref. 8].

The Area Common User System has two independent management facilities that perform most of the same functions required for the Integrated System Control. The Communications System Control Element is the management facility at the echelons above corps level and the System Control Center-2 fulfills this task at the echelons corps and below level. However, both of these management facilities are deficient in real-time network monitoring.[Ref. 9] & [Ref. 10]

II. NETWORK MANAGEMENT SYSTEM REQUIREMENTS

This chapter specifies a definition of a wide area network and network management. These definitions focus which network management functional area the Army Tactical Telephone Network Management System is associated with. Next, the management system implementation requirements and network model are covered. A detailed communications example is presented to illustrate how the equipment provides communications. This chapter concludes with a definition of the network management system reaction requirements.

A. NETWORK MANAGEMENT DEFINITIONS

The term wide area network refers to a communications network that supports subscribers in an area larger than 50 square km. Since the Area Common User System can support an area in excess of 1,000,000 square km it falls into this category.

Network management is composed of four functional areas: network operational control, network administration, network analysis and tuning, and network capacity planning.[Ref. 11]

Network operational control is a collection of activities that assist a user in dynamically maintaining a network's service levels. Some of the activities in this area are evaluating network events, collecting network data, processing on-line and off-line maintenance, and determining network problems. Operational control response time can range from real-time to one day.[Ref. 11]

Network administration is the second functional area of network management. It deals with activities that maintain network equipment inventories, network changes, evaluation of network service levels, and trouble tickets. The response time for network administration can range from one to 40 days.[Ref. 11]

The next functional area is network analysis and tuning. This functional area provides network managers with an ongoing quantitative evaluation of a network. It verifies that service levels are maintained, locates actual and potential bottlenecks, and provides

network trend reports. Network analysis and tuning cycles typically can take a few weeks to complete.[Ref. 11]

Network capacity planning is the final functional area in network management. Constructing the optimal network is the goal of the network capacity planner. In order to determine the optimal network, the network capacity planner must perform the following steps: collect network data, develop network requirements, design and optimize network, and implement network. Network capacity planning can take six months to two years to complete.[Ref. 11]

The Army Tactical Telephone Network Management System falls under the operational control functional area. The justification for this is that the management system will be evaluating event notifications, i.e., line-of-sight radio shelter status messages.

B. MANAGEMENT SYSTEM IMPLEMENTATION REQUIREMENTS

The ultimate goal of this thesis is to present a version of the Army Tactical Telephone Network Management System that will operate as a module of the Integrated System Control. Therefore, the network management system will comply with the Integrated System Control's implementation requirements. These requirements state that the system will be implemented in the Ada programming language and will operate on a hardware platform that supports the Unix Operating System and the X Window Graphical Interface System.[Ref. 1]

C. TACTICAL TELEPHONE NETWORK MODEL

The program for this thesis is limited to a fixed network consisting of three nodes and will allow the user to view the network at four levels. These four levels are the network level, nodal level, internodal level, and line-of-sight radio shelter component level. The user can determine the display objects' status by a color scheme. This color scheme will be described later in this chapter. The Echelons Above Corps Area Common User Subsystem equipment is used in this network model. However, this equipment is used to model the entire Area Common User System since all circuit switches and line-of-sight radio shelters

provide the same basic functions respectively. The differences between the different circuit switches and line-of-sight radio shelters are their capacity and components. The remainder of this section defines each level and explain the role of each display object.

The network level is the top level of the network and is used to display the overall network status (see Figure 4). At this level there are three nodes. Each node represents the overall status of its corresponding nodal level. Each node is connected to the other adjacent nodes through internodal line-of-sight radio links. Each node is identified by the format label N_x , where x represents a number. For example, the $N1$ represents node one. Internodal links are identified by the format label L_{yz} , where y represents the link originator node number and z represents the link terminator node number. For example, $L23$ represents the internodal link that originates at node two and terminates at node three.

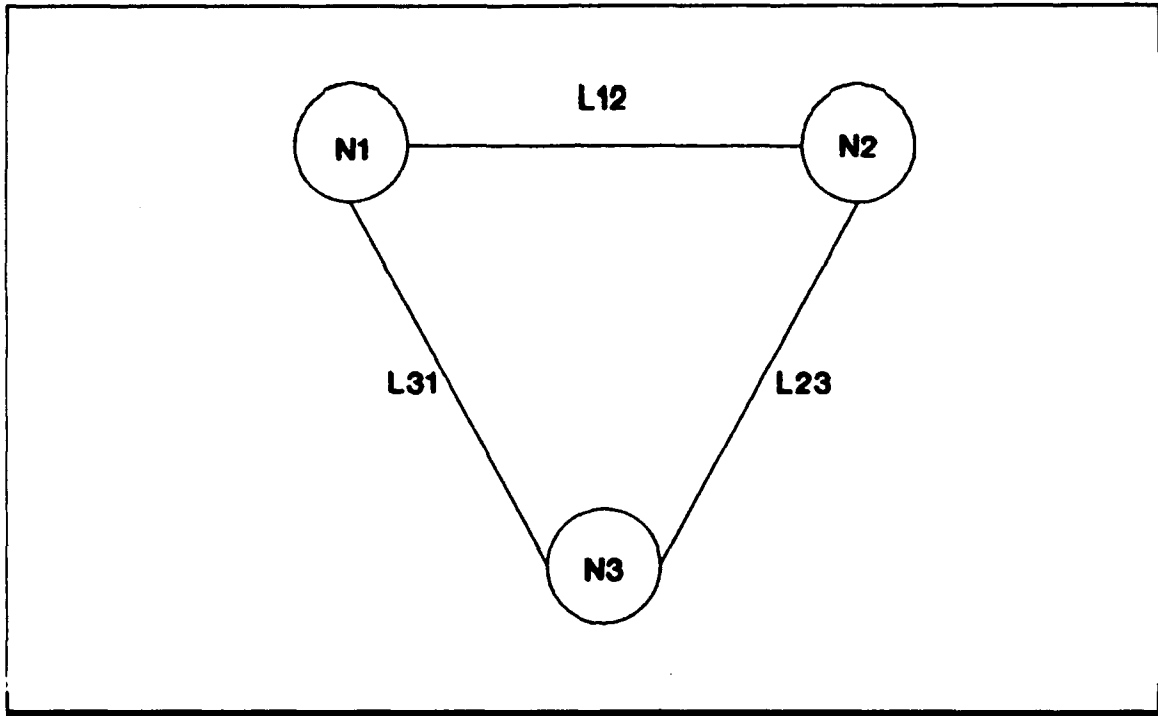

Figure 4: Network Level

The nodal level is an expanded view of a particular node at the network level (see Figures 5-7). Each of the three nodal level's equipment and link layout are basically the

same. At each nodal level there are six line-of-sight radio shelters (labeled TRC-173), one circuit switch (labeled TTC-39D), and three telephone multiplexers (labeled RMC). At each nodal level TRC-173s and the TTC-39Ds are identified by the label format C_x. The telephone multiplexers are identified by a two digit number. This equipment is interfaced together through a combination of cable and radio links. Cable and intranodal radio links are identified by the label formats Cx and Lx respectively. The internodal links are identified as stated above.

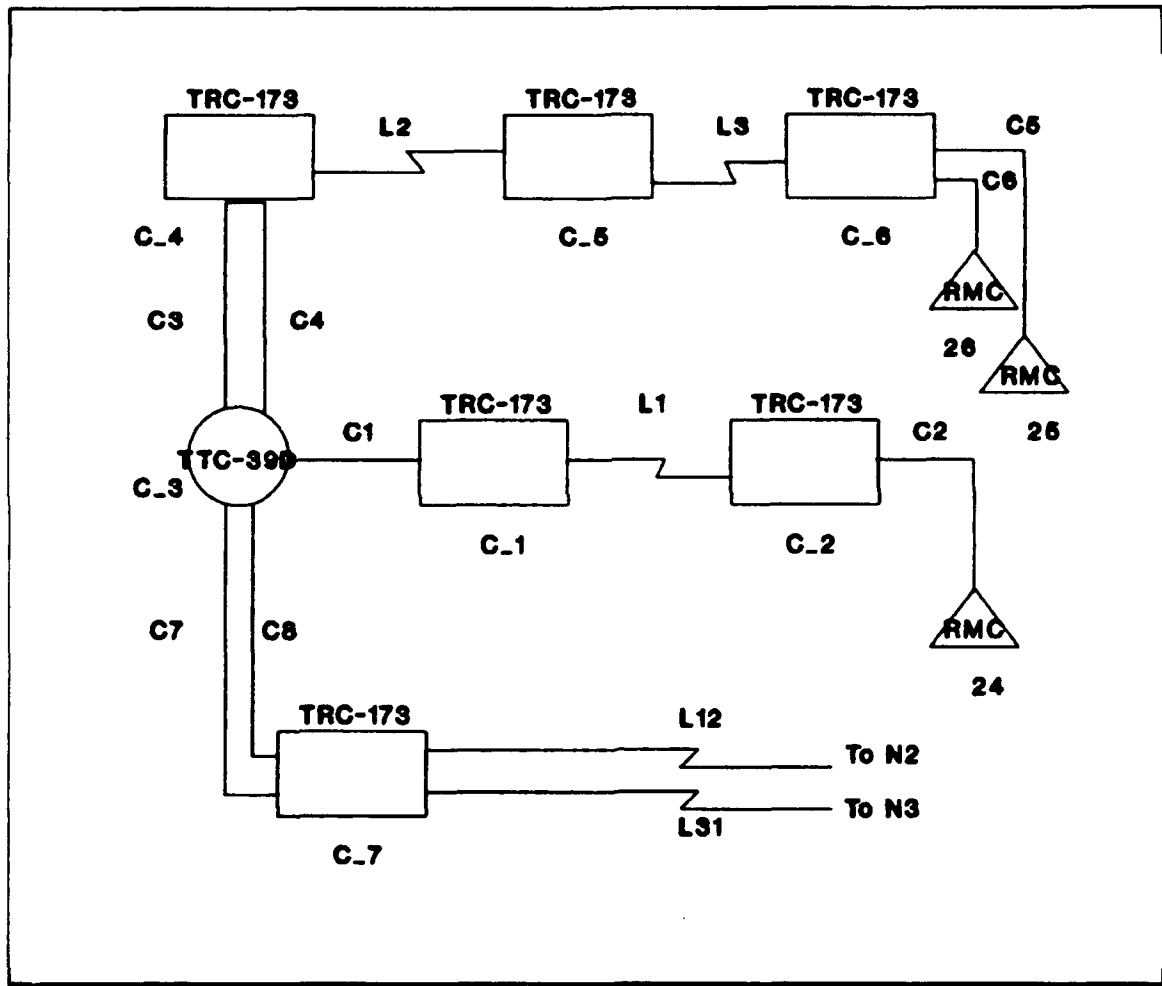

Figure 5: Node 1 Level

The internodal level is an isolated view of the transmission path between two circuit switches (see Figures 8-10). For example, internodal link L12 level displays only the

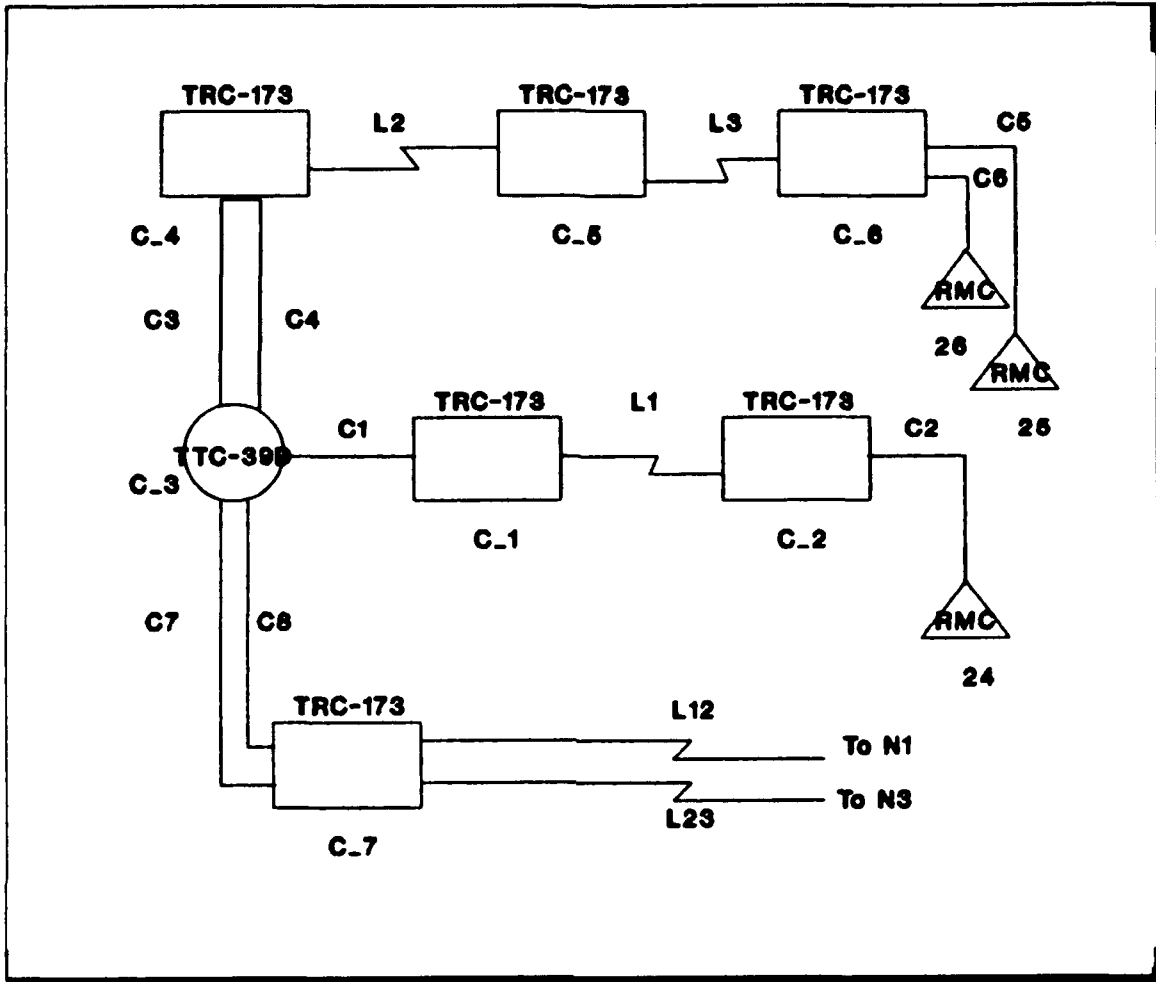

Figure 6: Node 2 Level

equipment and links involved in the path between the circuit switches at N1 and N2. The identification and labeling of display objects are as stated above.

The line-of-sight radio shelter component level displays the internal components of a specific TRC-173 (see Figure 11). A detailed listing and function of the TRC-173's components is given in the next section.

In this network model there are two types of display objects - active and passive. Active display objects generate a status message. TRC-173 line-of-sight radio shelters are the only objects that can be active in this model. TRC-173s become active only when they

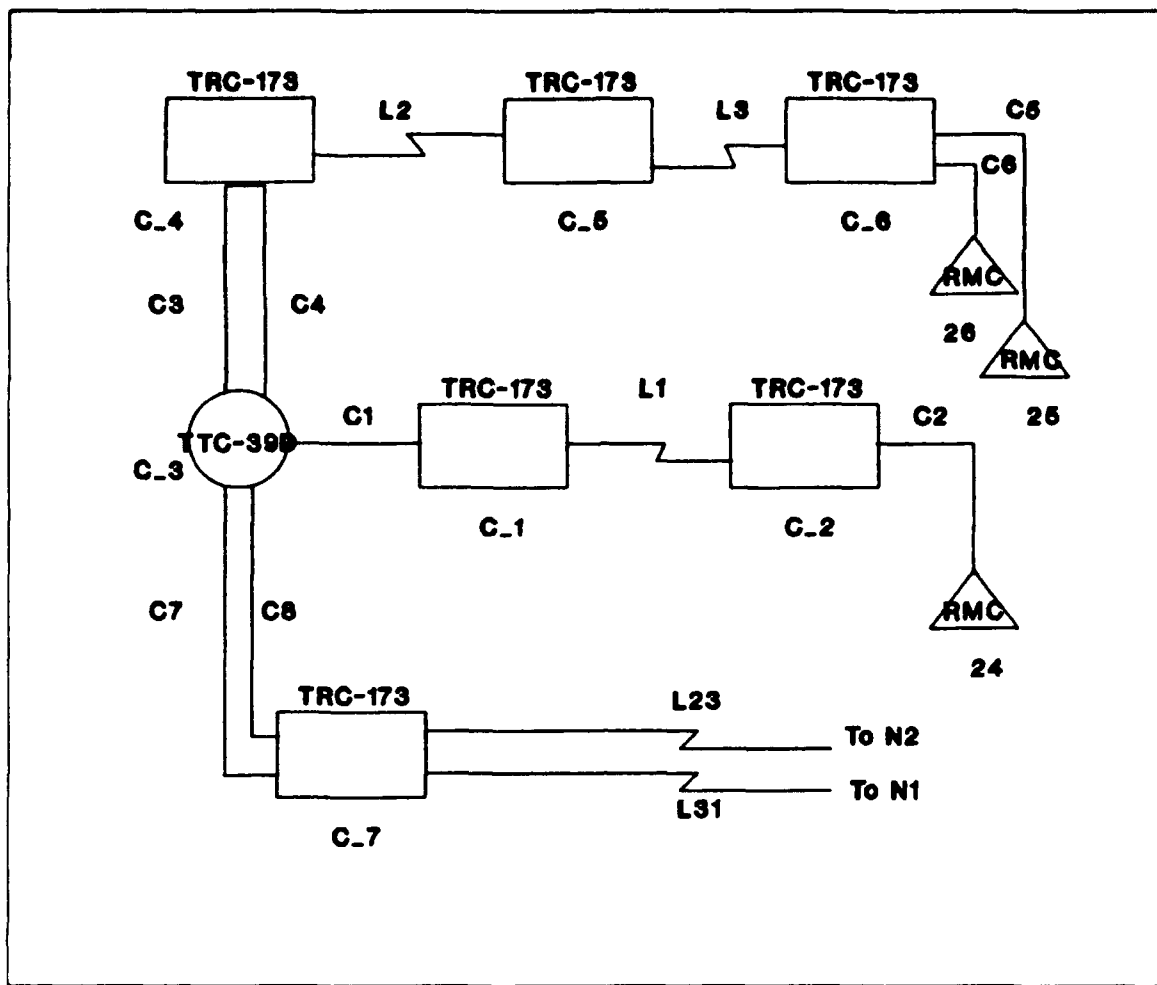

Figure 7: Node 3 Level

generate a status message. All other objects, to include non-active TRC-173s, are passive and they react to a status message.

D. TACTICAL TELEPHONE SYSTEM OVERVIEW

This portion of the chapter provides an overview of how the actual objects in this model provide communications. The following topics are covered: the concept of a *digital transmission group* (DTG), telephone multiplexer service, trunking between circuit switches, TRC-173 line-of-sight radio shelter components; and local and long distance telephone calls.

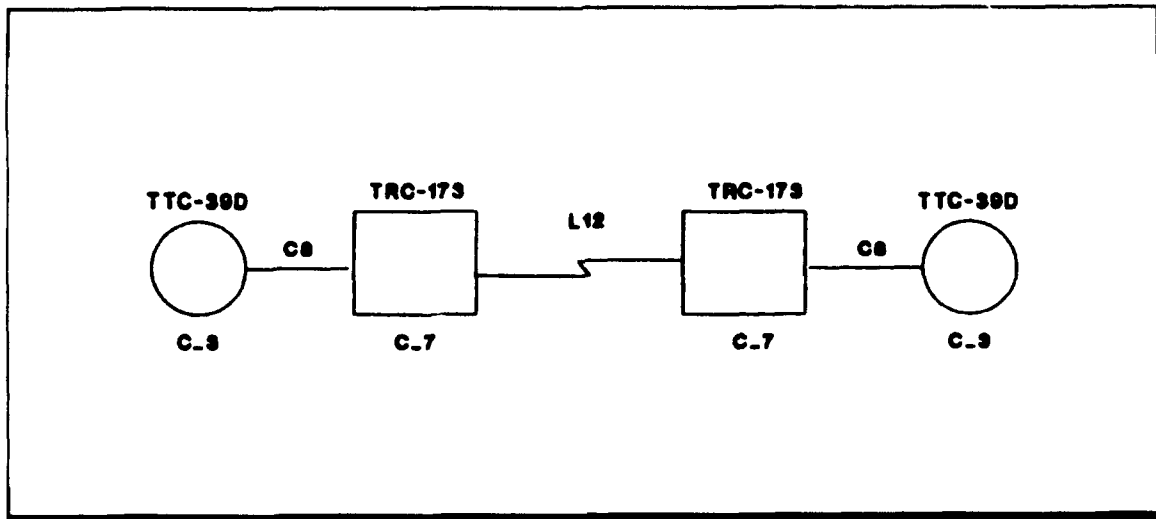

Figure 8: Internodal L12 Level

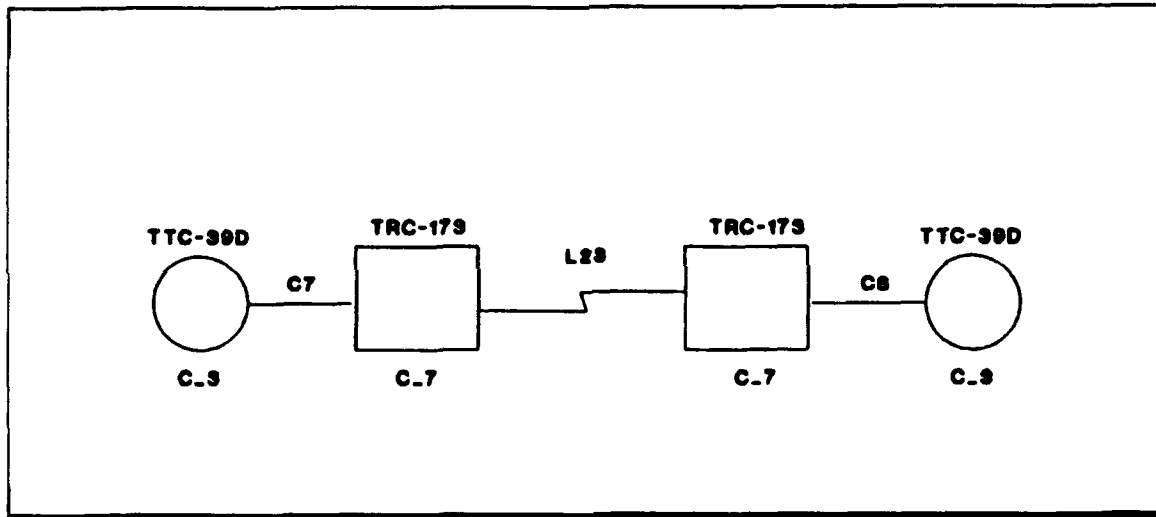

Figure 9: Internodal L23 Level

The term digital transmission group refers to a collection of full duplex channels which connect two nodes. These channels can be trunks, telephone loops, or data loops. Digital transmission groups originate from a circuit switch and terminate either to another circuit switch, a telephone multiplexer device, or another type of terminating equipment. Digital transmission groups can be transmitted over cable or radio links. Multiple digital transmission groups (known as super groups) can be multiplexed together and transmitted

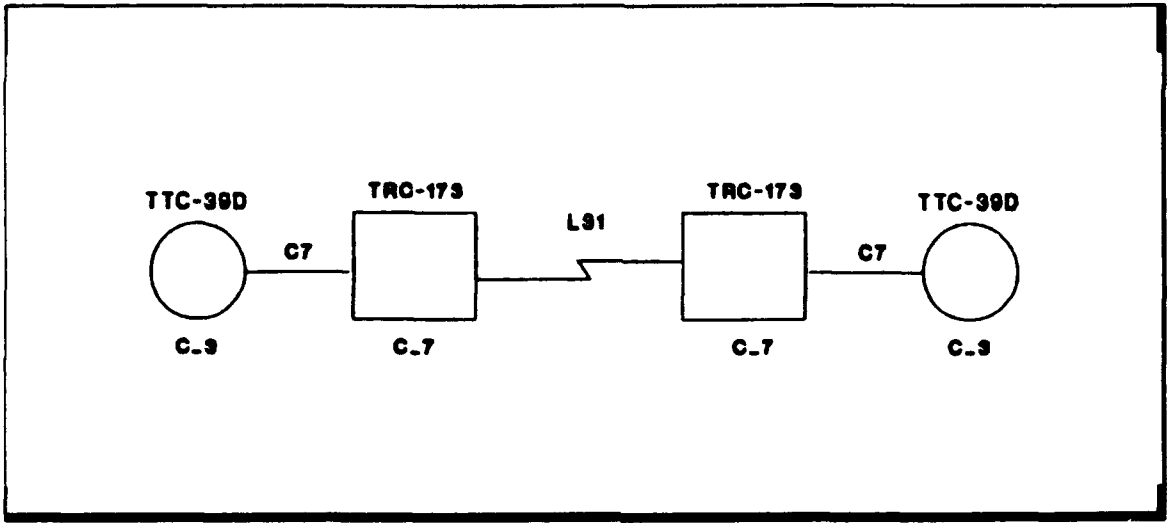

Figure 10: Internodal L31 Level

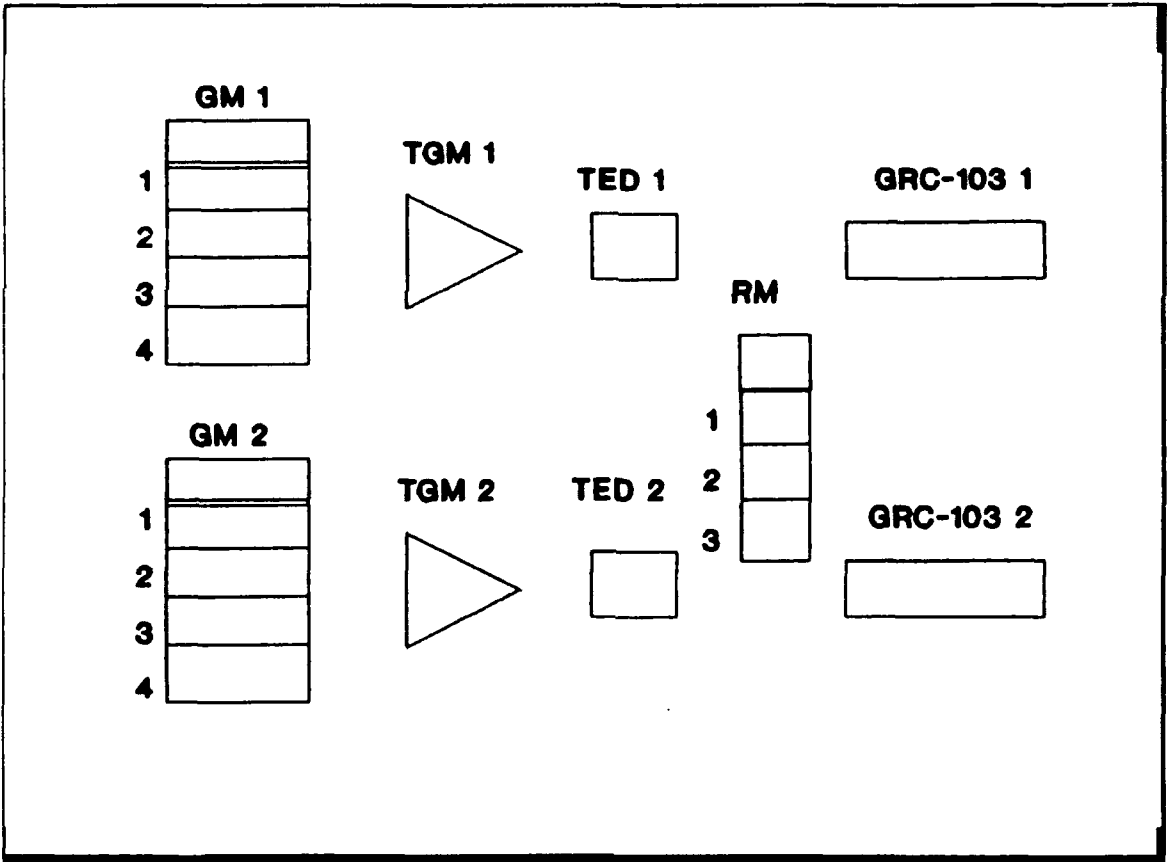

Figure 11: TRC-173 Component Level

over links. Super groups can be demultiplexed into separate digital transmission groups or super groups and then be transmitted to different destinations. In this network model all digital transmission groups have nine channels and each one operates at 32 kbps for a total rate of 288 kbps. Eight of these channels are available to users and one is reserved for common channel signaling.

Trunks provide communication paths between different circuit switches. In almost all cases trunks between circuit switches are a combination of cable and radio links. Cable links are used to connect equipment that is separated by a short distance, i.e., 5 km or less. They are used to connect the following equipment: a circuit switch to line-of-sight radio shelters, line-of-sight radio shelters, and circuit switches in special situations. Radio links greatly increase the distance between circuit switches, i.e., 40 km. In this network model there will be eight trunks between each pair of circuit switches.

The TRC-173 line-of-sight radio shelter is used to extend the connectivity of the network through radio links. In the Area Common User System, the TRC-173 is primarily utilized as a terminator. However, it also has the capability to function as a relay. Since the TRC-173 can function in both roles, it was chosen to model all the other Area Common User System radio shelters.

Since the TRC-173 line-of-sight radio shelter is the only active object in this network model a basic understanding of how it functions is needed. Figure 12 is used to display each component in the shelter. The components of the TRC-173 are *Group MODEM (GM)*, *Trunk Group Multiplexer (TGM)*, *Trunk Encryption Device (TED)*, *Radio MODEM (RM)*, and GRC-103 microwave radio unit. [Ref. 4]

The Group MODEM (GM) is the first TRC-173 component to be discussed. The purpose of the Group MODEM is to provide an interface from a cable link to the TRC-173. The Group MODEM converts a cable link signal to a *nonreturn to zero (NRZ)* signal and a NRZ signal into either conditioned diphasic, dipulse, or bipolar signal. There are four cable connection slots per Group MODEM and there are two Group MODEMs per shelter. [Ref. 4]

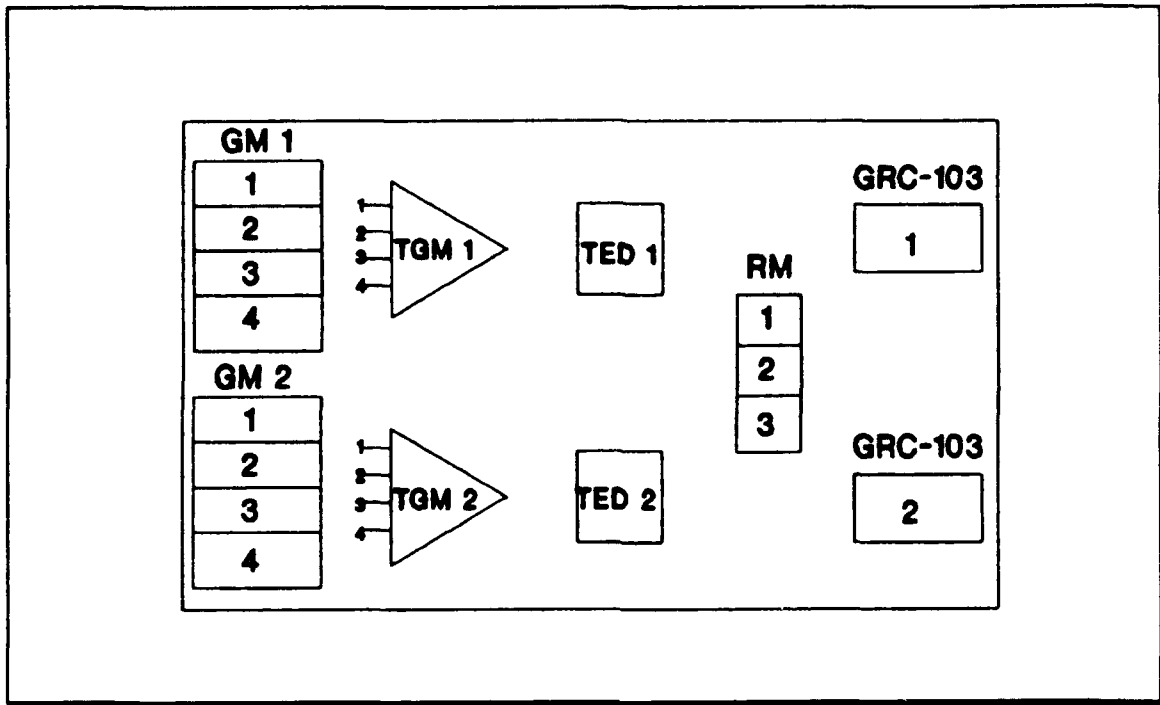

Figure 12: TRC-173 LOS Radio Shelter

The next component is the Trunk Group Multiplexer which multiplexes and demultiplexes up to four NRZ signals from a Group MODEM. There are a total of two Trunk Group Multiplexers per TRC-173.[Ref. 4]

A Trunk Encryption Device can be connected to each Trunk Group Multiplexer to encrypt and decrypt the signals passing through it.[Ref. 4]

The Radio MODEM converts the NRZ signal from the Trunk Encryption Device to a radio binary signal and a radio binary signal into a NRZ signal. There are three MODEM slots in a Radio MODEM unit.[Ref. 4]

The final component in the TRC-173 is the GRC-103 microwave radio unit. The radio unit transmits the radio binary signal from the Radio MODEM and receives a radio binary signal from a distant TRC-173. There are two GRC-103 microwave radio units per shelter.[Ref. 4]

A *Remote Multiplexer Combiner* (RMC) is a device that multiplexes and demultiplexes up to eight full duplex telephone loops. It transmits and receives a multiplexed signal via a cable link.[Ref. 4]

Figure 13 illustrates how the equipment discussed above provides telephone service. In this example there are four digital transmission groups. *Circuit switch* (CS) 1 originates DTGs 1, 2, and 3 and CS 2 originates only DTG 4. DTG 1 is used to provide trunking between CS 1 and CS 2. DTGs 3 and 4 provide local site telephone service through RMC 1 and RMC 2 respectively. DTG 2 provides site 3 with telephone service through RMC 1 from CS 1.

The network connection between all sites is provided by the TRC-173 line-of-sight radio shelters. The TRC-173 radio shelters in this example provide either a terminator or relay function. There are four line-of-sight terminators in this network: LOS 1, LOS 3, LOS 4; and LOS 5. LOS 2 functions as the only relay. LOS 1's GM 1 slots 1 and 2 transmit and receive signals from C1 and C2 from CS 1 (DTGs 1 and 2 respectively). Internally a path is created through LOS 1 from GM 1 slots 1 and 2, TGM 1, TED 1, RM slot 1, and GRC-103 radio unit 1. The product of the Trunk Group Multiplexer is a super group consisting of DTGs 1 and 2. LOS 2 is a relay to LOS 1 and LOS 3. The internal path for LOS 2 requires a direct connection between the two GRC-103 radio units. The internal paths in LOS 3 are the same as LOS 1. However, once the super group is decomposed DTG 1 via GM 1 slot 1 is cable linked (terminated) to CS 2 and DTG 2 via GM 1 slot 2 is cable linked to LOS 4's GM 1 slot 1. LOS 4 creates an internal path from GM 1 slot 1, TGM 1, TED 1, RM slot 1, and GRC-103 radio unit 1. LOS 5 has the same internal path as LOS 4. DTG 2 is terminated at RMC 3 via a cable link from LOS 5's GM 1 slot 1.

A local telephone call is defined as both the calling and called telephones receiving telephone service from the same circuit switch. In Figure 5, calls placed from sites 1 or 3 to sites 1 or 3 and from site 2 to site 2 are considered local calls.

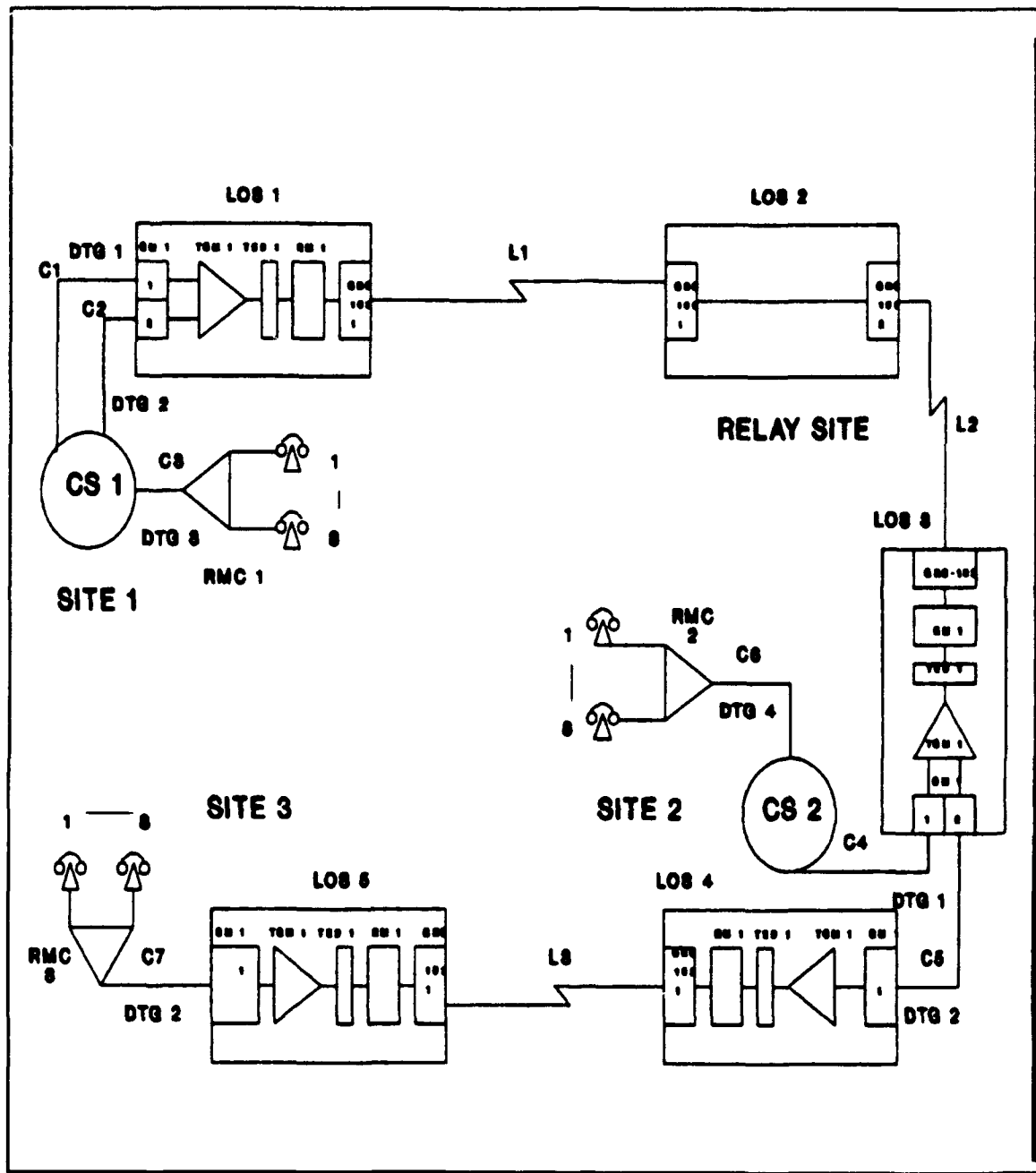

Figure 13: Telephone Service Example

A long distance telephone call is defined as both the calling and called telephones receiving telephone service from separate circuit switches. In Figure 5, calls placed from sites 1 or 3 to site 2 or from site 2 to sites 1 or 3 are considered long distance telephone calls.

E. MANAGEMENT SYSTEM REACTION REQUIREMENTS

1. Background Information

In the Army Tactical Telephone Network Management System, display objects can be one of four status colors. The status color green represents that a display object is fully functional. The orange status color indicates that a display object is partly functional. The status color blue means that the display object is nonfunctional due to no fault of its own. This status is assigned to a display object when it is not receiving input from some point along the transmission path. The status color red means that the display object is nonfunctional due to a fault of its own. The status color ranking from lowest to highest is as follows: green, orange blue and red.

There are two categories of components in any line-of-sight radio shelter: those components in-system and those not in-system. Components that are in-system are in the radio shelter's internal path to external links. Not in-system components are those components that are not in a radio shelter's internal path to external links. Figure 14 shows a TRC-173 with the following components in-system: GM 1 slots 1 and 2, TGM 1, TED 1, RM slot 1, and GRC-103 1. All other components in this TRC-173 are categorized as not in-system.

In-system components fall into one of two classes: external or internal interface capable. External interface capable components interface directly with a cable or radio link. On the other hand, internal interface capable components do not have this capability. They indirectly interface with a cable or radio link. In a TRC-173 line-of-sight radio shelter, only Group MODEMs and GRC-103 microwave radio units can be classified as external interface components. All the other components can be classified as internal interface components (see Figure 15).

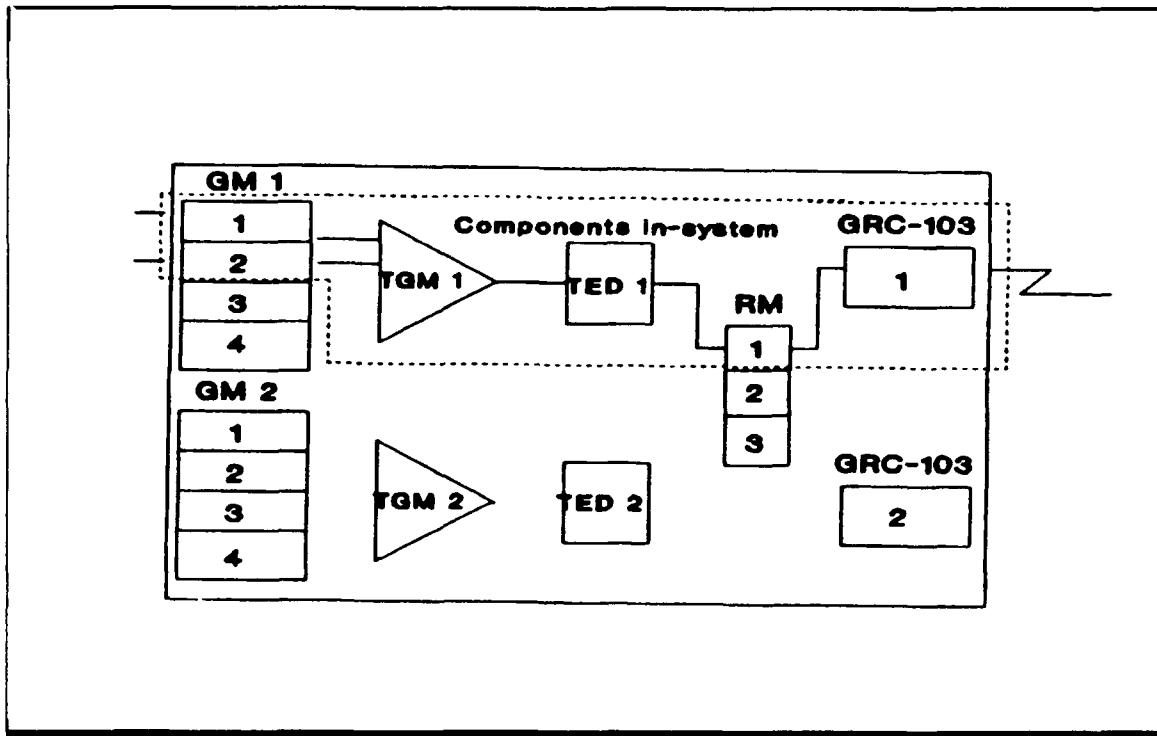

Figure 14: In-System Components Example

2. Network Reaction Requirements

With the above terminology defined, the various network reactions to a TRC-173 status message can be defined. The remainder of this chapter will specify status message reaction at the following levels: active TRC-173 level, nodal and internodal levels, and the network level.

a. Active TRC-173 Level Requirements

These reaction requirements will be presented in the following groupings: not in-system components, internal in-system components, and external in-system components.

(1) Not In-System Component Requirements. When the Area Tactical Telephone Network Management System receives a red TRC-173 status message for a green not in-system component, the system will change the appropriate TRC-173's component status to red. If the component identified in the status message is a Group

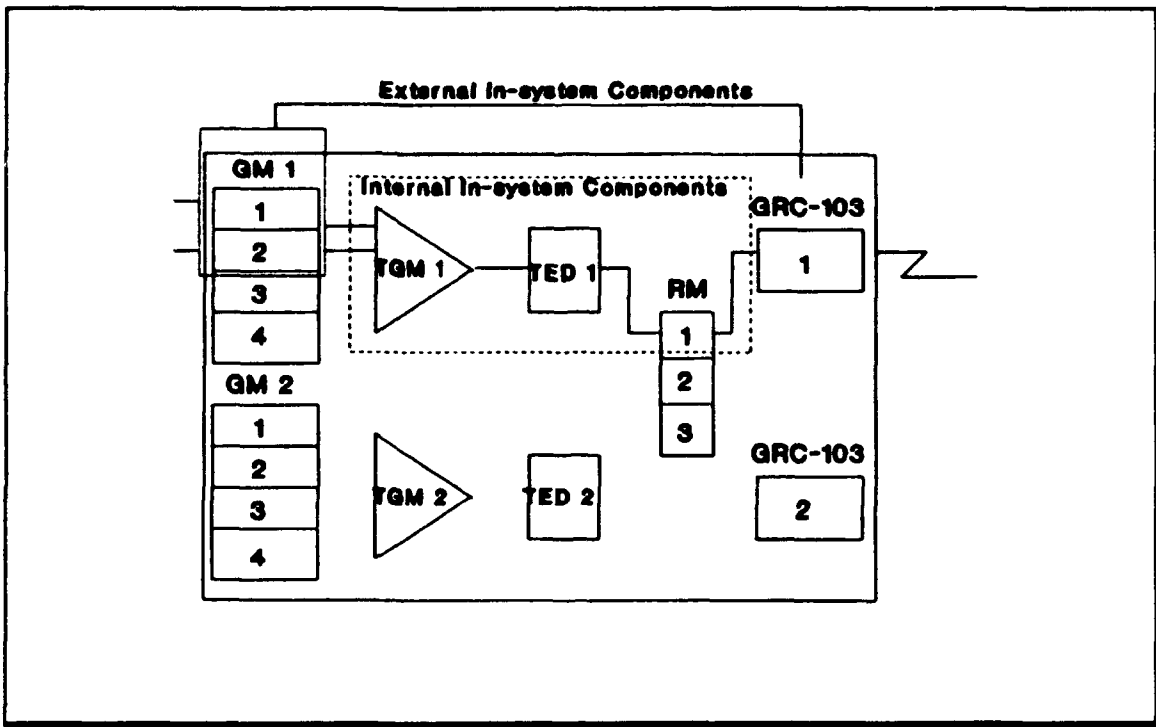

Figure 15: External and Internal Components Example

MODEM slot or an Radio MODEM slot, the management system will check if all slots are red. If true, the overall Group MODEM or Radio MODEM component status is changed to red. If false, the overall status is changed to orange. The overall status for the TRC-173 that generated the status message is based on the following: Orange - if the current status is green or orange, Blue - if the current status is blue, or Red - if the current status is red.

On the other hand, if the network management system receives a green TRC-173 status message for a red not in-system component, the system will change the appropriate TRC-173's component status to green. If the component identified in the status message is a Group MODEM slot or a Radio MODEM slot, the management system will check if all slots are green. If true, the overall Group MODEM or Radio MODEM component status is changed to green. If false, the overall status is changed to orange. The overall status for the TRC-173 that generated the status message is based on the following: Green - if all component statuses are green and all link statuses are green, Orange - if a component is orange or a not in-system component is red and at least one link is green or

orange, Blue - if all links are a combination of blue and red and no pending overall TRC-173 status of red, or Red - if pending overall TRC-173 status is red.

(2) Internal In-System Component Requirements. Some of the following reaction requirements are similar and, in some cases, will be identical to the above section.

When the Area Tactical Telephone Network Management System receives a red TRC-173 status message for a green internal in-system component, the system will change the appropriate TRC-173's component status to red. If the component identified in the status message is an Radio MODEM slot, the system checks if all slots are red. If true, the overall Radio MODEM component status is changed to red. If false, the overall status is changed to orange. All cable and radio links that indirectly pass through this component will have their status changed to blue if their current status is green or orange. However, no link's status will be changed if its current status is blue or red. The overall status for the TRC-173 that generated the status message is based on the following: Orange - if at least one link is green or orange or Red - if all the links have either a blue or red status.

If the management system receives a green TRC-173 status message for a red internal in-system component, the system will change the appropriate TRC-173's component status to green. If the component identified in the status message is a Radio MODEM slot, the system checks if all slots are green. If true, the overall Radio MODEM component status is changed to green. If false, the overall status is changed to orange. All the cable and radio links that pass through the component identified in the status message will have their status changed to green if the following is true: the current link status is blue and the blue status was produced by a previously processed red status message for this component. In all other cases the current link status will not be changed. The overall status for the identified TRC-173 will be determined by the following rules: Green - if all links are green, Orange - if all links are orange or a combination of green and orange, Blue - if all links are blue or red or a combination of blue and red and no pending overall TRC-173 status of red, and Red - if pending overall TRC-173 status of red.

(3) External In-System Component Requirements. Once again, the reaction requirements that follow will resemble the previous sections.

When the management system receives a red TRC-173 status message for a red external in-system component, the system will change that component's status to red. If the component identified in the status message is a Group MODEM slot, the system checks if all slots are red. If true, the overall Group MODEM component status is changed to red. If false, the overall status is changed to orange. If the identified component identified in the status message is a Group MODEM slot, then the status of the connected cable link is changed to red. The radio link that is indirectly connected to the Group MODEM slot will receive a status based on the following: Orange - if there is at least one cable link that is green or orange or Blue - if all cable links that are indirectly connected to this link are blue or red. If the component identified in the status message is a GRC-103 radio, then the associated radio link status is changed to red. All the cable links that are indirectly connected to this GRC-103 radio will receive a blue status unless there is a pending red status. The overall status for the TRC-173 that generated the status message is based on the following: Orange - if at least one link is green or orange or Red - if all the links have either a blue or red status.

If the network management system receives a green TRC-173 status message for a red external in-system component, the system will change that component's status to green. If the component identified in the status message is a Group MODEM slot, the system checks if all the Group MODEM slots are green. If true, the overall Group MODEM component status is green. If false, the overall component status is orange. The cable link connected to the Group MODEM will have a status of green if the following is true: the current status is blue and the blue status was produced by a previously processed red status message for this component. In all other cases the current cable link status will not be changed. The radio link that is indirectly connected to the Group MODEM slot will receive a status based on the following: Green - if all cable links that are transmitted over this radio link are green, Orange - if there is at least one cable link that is transmitted over

this radio link which is green or orange, Blue - if all cable links that are transmitted over this radio link are any combination of blue or red, or Red - if the associated GRC-103 radio unit has a status of red. If the identified component in the status message is a GRC-103 radio, then the associated radio link status is green if the following is true: the current status is red and there are no other pending non-green statuses. In all other cases the highest pending status will be assigned to the radio link's status. The overall status for TRC-173 that generated the status message is based on the following: Green - if all links are green, Orange - if at least one link has a status of green or orange, Blue - if all links are blue or red or a combination of blue and red and no pending overall TRC-173 status of red or Red - if pending overall TRC-173 status of red.

b. Nodal and Internodal Levels Requirements

A status message will propagate from the TRC-173 which generated it in two directions. These two directions are to the origination and termination points of the affected digital transmission group(s). The following example will illustrate message propagation. Figure 16 shows a nodal level consisting of a circuit switch, two TRC-173s, and a Remote Multiplexer Combiner. CS 1 is the originating point for DTG 1 and RMC 1 is its terminating point. DTG 1 is transmitted from the CS 1 to the RMC 1 by C1, LOS 1 (GM 1 slot 1, TGM 1, TED 1, RM slot 1, and GRC-103 1), L1, LOS 2 (GRC-103 1, RM slot 1, TED 1, TGM 1, and GM 1 slot 1), and C2. At this point, the entire network has a green status. Figure 17 shows that LOS 2 generated a red status message for GRC-103 1. This caused LOS 2's GRC-103 1 status to change to red, LOS 2's overall status to change to red, L1's status to change to red, and C2's status to change to blue (per the above active TRC-173 requirements). This status message indicates that DTG 1's path has been disrupted. Therefore, the message propagates from LOS 2 to DTG 1's origination and termination points. The propagated status message caused the status of the CS 1, C1, LOS 1, and RMC 1 to transition to blue (rules for these status changes are given below). Figure 18 shows that LOS 2 generated a green status message for GRC-103 1. This indicates that

DTG 1's path has been restored and therefore the network's status has been returned to green. The above example can be modified to demonstrate a internodal level by replacing the RMC 1 with CS 2 and L1 with L12.

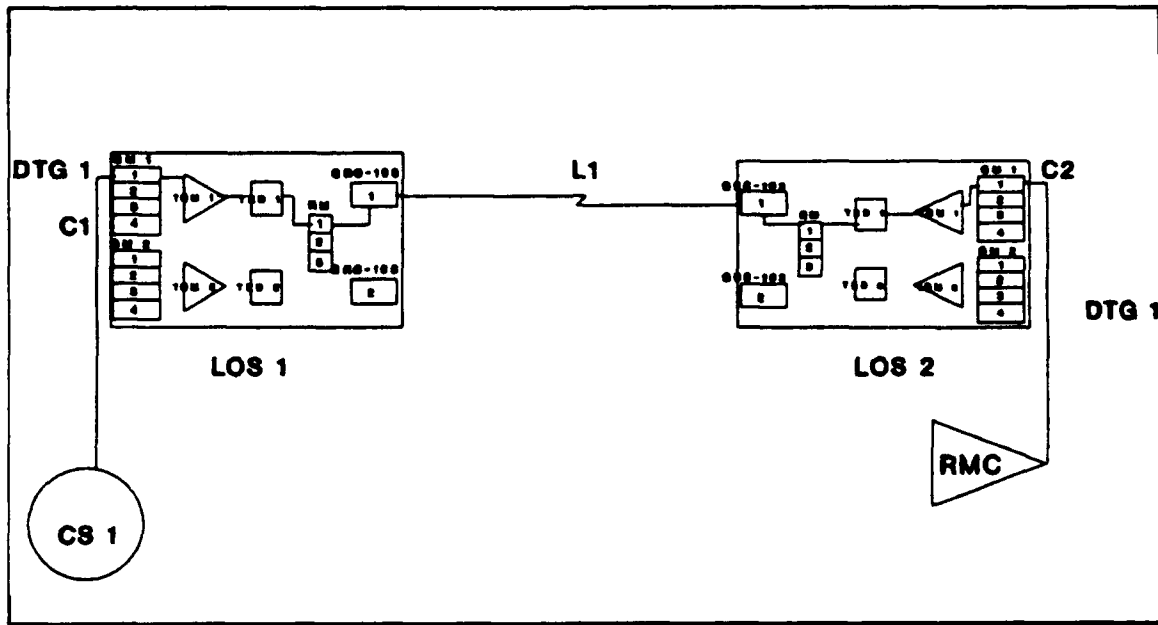

Figure 16: Propagation Example Part a

The requirements for nodal and internodal passive objects affected by status message propagation will be presented in the following order: link objects; TRC-173 objects; and circuit switch and Remote Multiplexer Combiner objects. The reader is advised that the following requirements will resemble and in some cases will be identical to each other. However, the slight differences between the requirements are significant and should be read carefully.

(1) Link Object Status Message Propagation Requirements. The overall status for a link object affected by the propagate of a status message is based on the following: Green - if all required digital transmission groups are being transmitted over the link, Orange - if at least one of many digital transmission groups are being transmitted over the link, Blue - if the current status is not red and none of the required digital transmission groups are being transmitted over the link, or Red - if the current status is red.

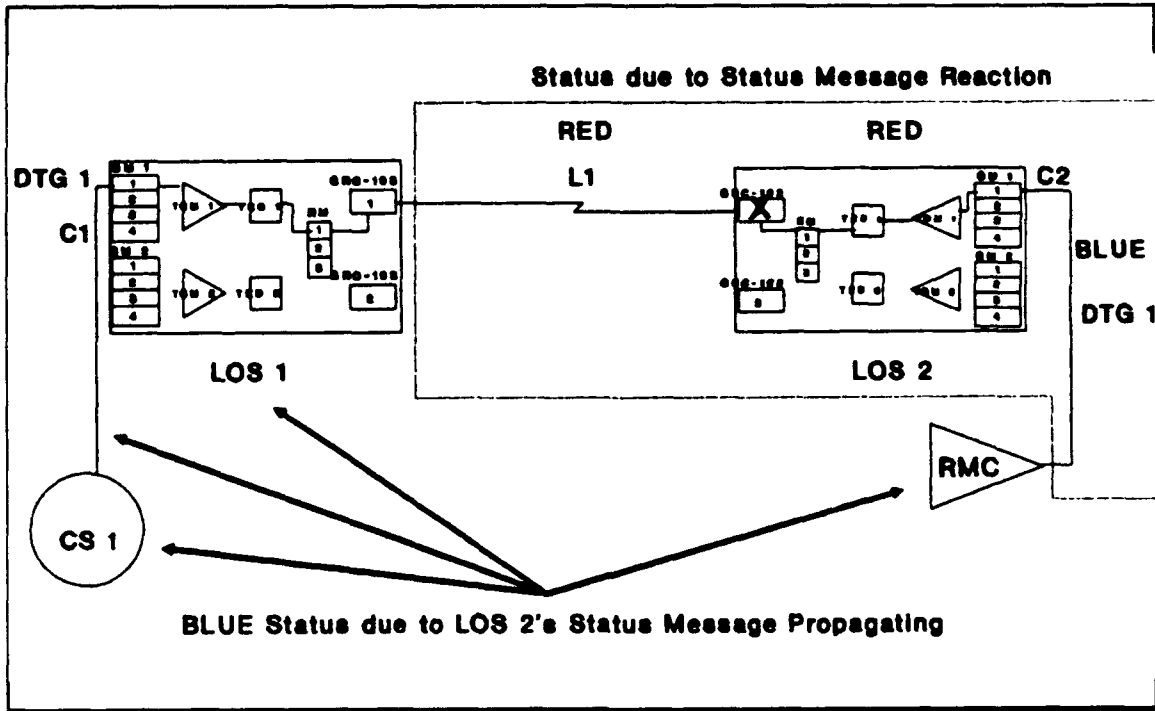

Figure 17: Propagation Example Part b

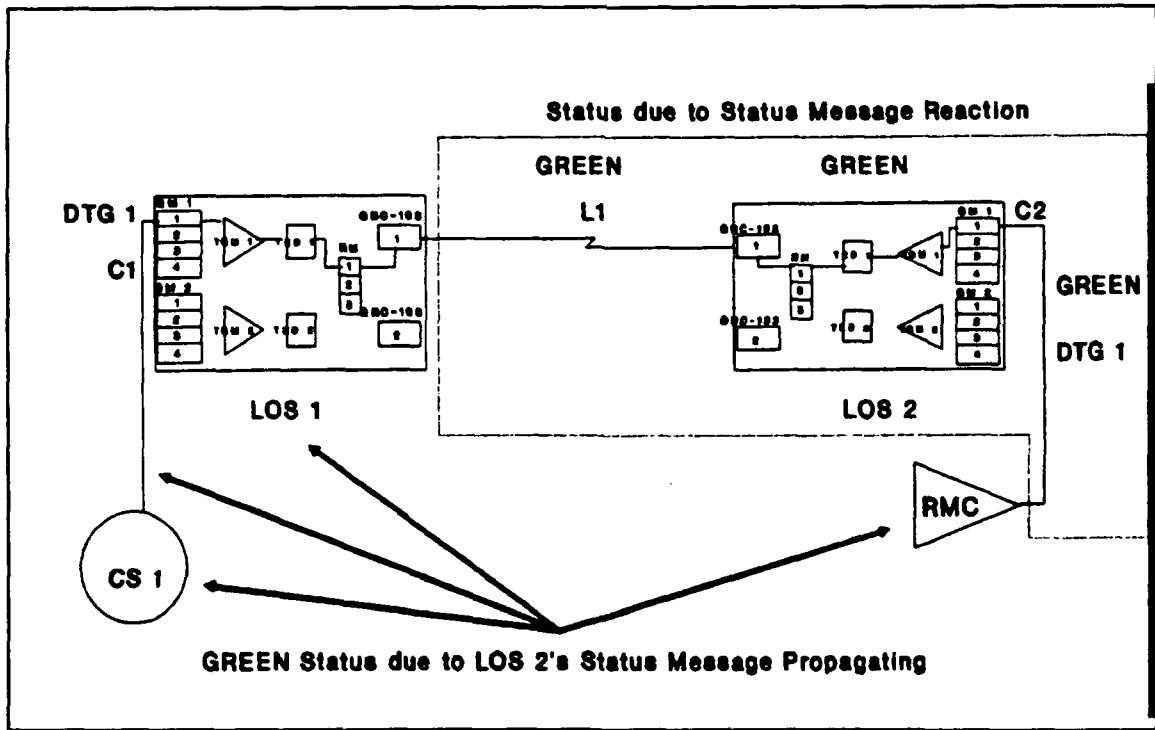

Figure 18: Propagation Example Part c

(2) TRC-173 Object Status Message Propagation Requirements. The overall status for a TRC-173 object that is affected by the propagation of a status message is based on the following: Green - if all the links connected to the TRC-173 are green, Orange - if at least one link connected to the TRC-173 is green or orange, Blue - if the current TRC-173 status is not red and the links connected to the TRC-173 are either all blue or red; or Red - if the current TRC-173 status is red.

(3) CS and RMC Objects' Status Message Propagation Requirements. The overall status for a circuit switch or Remote Multiplexer Combiner object that is affected by the propagation of a status message is based on the following: Green - if all the cable links connected to the object are green, Orange - if at least one cable link connected to the object is green or orange or Blue - if the cable links connected to the object are either blue or red.

c. Network Level Requirements

At the network level there are two reaction requirements. First, the network level nodes must receive the same status as their corresponding circuit switches. The second requirement is to have the network level radio links receive the same status as their corresponding internodal radio links at the appropriate nodal and internodal levels.

III. NETWORK MANAGEMENT SYSTEM DESIGN

This chapter provides an Army Tactical Telephone Network Management System overview. Following this, a detailed presentation of the management system design is given. The Army Tactical Telephone Network Management System is divided into the following three segments: panel, status message processing, and system management control. The panel segment is responsible for displaying the various network levels and display objects. The Transportable Applications Environment Plus Version 5.1 software development tool is used to design the panel segment. The status message processing segment is responsible for processing TRC-173 line-of-sight radio shelter status messages and updating the network database. The system management control segment is responsible for the following: initially receiving the status message, sending a received status message to the status message processor, and updating the panel display objects. Each of these segments are discussed in greater detail in this chapter. The Army Tactical Telephone Network Management System flow diagrams are contained in Appendix D.

A. NETWORK MANAGEMENT SYSTEM OVERVIEW

The Army Tactical Telephone Network Management System is a graphical panel-driven system. This means that the user is viewing a computer monitor displaying one of the four network levels discussed in Chapter II. In order to traverse to another panel, the user clicks a mouse on a display object's button. This action opens another panel depicting increased information of the object whose button was clicked. The user clicks the EXIT button to return to the previous panel. This process can continue until the user is at the desired panel level. The user determines the network's status by the display objects' status colors. In this system, there are some display objects that blink once their status changes. The purpose for blinking display objects is to draw the user's attention to a network event.

Initially the network level panel is displayed and all display objects are green. A node or internodal link display object starts to blink once a status message is received. At this point, the user moves the mouse to the blinking object's button and clicks it. This will open

the corresponding object's panel. If the button clicked was for a node the associated nodal level panel will be opened. At this level the user sees the status of this portion of the network. A blinking TRC-173 line-of-sight radio shelter represents the cause of the network level blinking. The user moves the mouse and clicks the blinking TRC-173's button. This action, will open the TRC-173 component level panel. The blinking component indicates the cause of the network status change. The user returns to the network level panel by clicking the EXIT button at both the TRC-173 component level and at the node level panels. If the button clicked at the network level is an internodal object, the corresponding internodal level panel is displayed. This level will provide a view of the trunk path status between two circuit switches. The blinking TRC-173 line-of-sight radio shelter is the cause of the network's status change.

This system operates in real-time. Therefore, additional TRC-173 line-of-sight radio shelter status messages can change the network's status while the user is exploring an old network reaction. Real-time status message generation is simulated by the management system reading a status message file at random intervals. The random read intervals are from 1 to 10 seconds.

B. PANEL DESIGN SEGMENT

This portion of the thesis is discussed in two sections. The first section presents general information about the Transportable Applications Environment Plus software development tool. The second section focuses on the actual design of each network level panel.

1. Transportable Applications Environment Plus General Information

Transportable Applications Environment Plus is a software development tool used for designing interactive graphical user interfaces. It operates on a Unix Operating System platform under the X Window System. This tool allows a user to design custom panels from the following presentation categories: data driven objects, selection, and text.

Data driven objects are display objects that can be manipulated in real-time. The network display objects used in the network management system are from this presentation category. The selection presentation category is used to provide a user with a facility to choose options from. Some of the presentation types in this category are push buttons (used in this management system), pulldown menus, and radio buttons. Text, the final presentation category, allows labeling of objects (used in this management system), user keyed-in values to be utilized by an application program, and program values to be displayed. Once panels are constructed Transportable Applications Environment Plus provides a facility to connect the panels in a desired order. Transportable Applications Environment Plus has the capability to generate code after panel connections are completed. This code generation facility can produce Ada (used in this management system), C, FORTRAN, or TCL (Transportable Applications Environment Plus programming language) code. The code that is produced is a template for full application development. Application-specific code is added to the template at Transportable Applications Environment Plus designated points.[Ref. 12]

2. Network Panel Designs

This section describes the following four network panel designs: network level panel, nodal level panel, internodal level panel, and TRC-173 line-of-sight radio shelter component level panel. All of these panels display the real-time status of their network portion. The network management system starts with all display objects green. A TRC-173 status message causes a network status change. Some display objects blink when their status is changed. This blinking continues until the user clicks the display object's button or exits the panel.

The network level panel displays the network level layout described in Chapter II. This panel contains the following display objects: three nodes and three internodal links. A corresponding push button is assigned to each display object. When a push button is clicked the appropriate nodal level or internodal level panel will be opened. To halt the

management system the user clicks the EXIT button. Both node and internodal link display objects can blink. Clicking these display objects' push buttons terminate their blinking.

There are a total of three nodal level panels that correspond with one of the nodal level layouts presented in Chapter II. Each panel contains push buttons for the following display objects: TTC-39D circuit switch, TRC-173 line-of-sight radio shelters, Remote Multiplexer Combiners, and internodal links. The only active push buttons are associated with the TRC-173s and internodal links. When an active push button is clicked the appropriate TRC-173 component level panel or internodal level panel will be opened. There is also an EXIT button that when clicked will return the user to the network level panel. Only TRC-173 line-of-sight radio shelter and internodal link display objects blink. Clicking these display objects' push buttons terminate their blinking.

Similarly, there are a total of three internodal level panels each corresponding with one of the internodal level layouts presented in Chapter II. Each panel has push buttons for the following display objects: TRC-173 line-of-sight radio shelters and TTC-39D circuit switches. The only active push buttons are associated with the TRC-173 line-of-sight radio shelters. A clicked button will display the TRC-173 line-of-sight radio shelter component level panel. There is also an EXIT button that when clicked will return to the user to the panel that called the Internodal Level Panel. Only TRC-173 line-of-sight radio shelters blink on Internodal Level Panels. Clicking these display objects' push buttons terminate their blinking.

The TRC-173 line-of-sight radio shelter component level panel displays the current component status of the TRC-173 that corresponds with the button that opened this panel. Since the TRC-173 line-of-sight radio shelter contains two microwave radio units there can be two separate in-system paths supported by the shelter. A label of either SYSTEM 1 or SYSTEM 2 identifies which components are in a particular in-system path. The absence of a label indicates that a component is not in-system. (see Figure 19) All component display objects can blink. When the EXIT button is clicked the user will return

to the panel that called the TRC-173 component level panel. This action terminates any blinking component display objects.

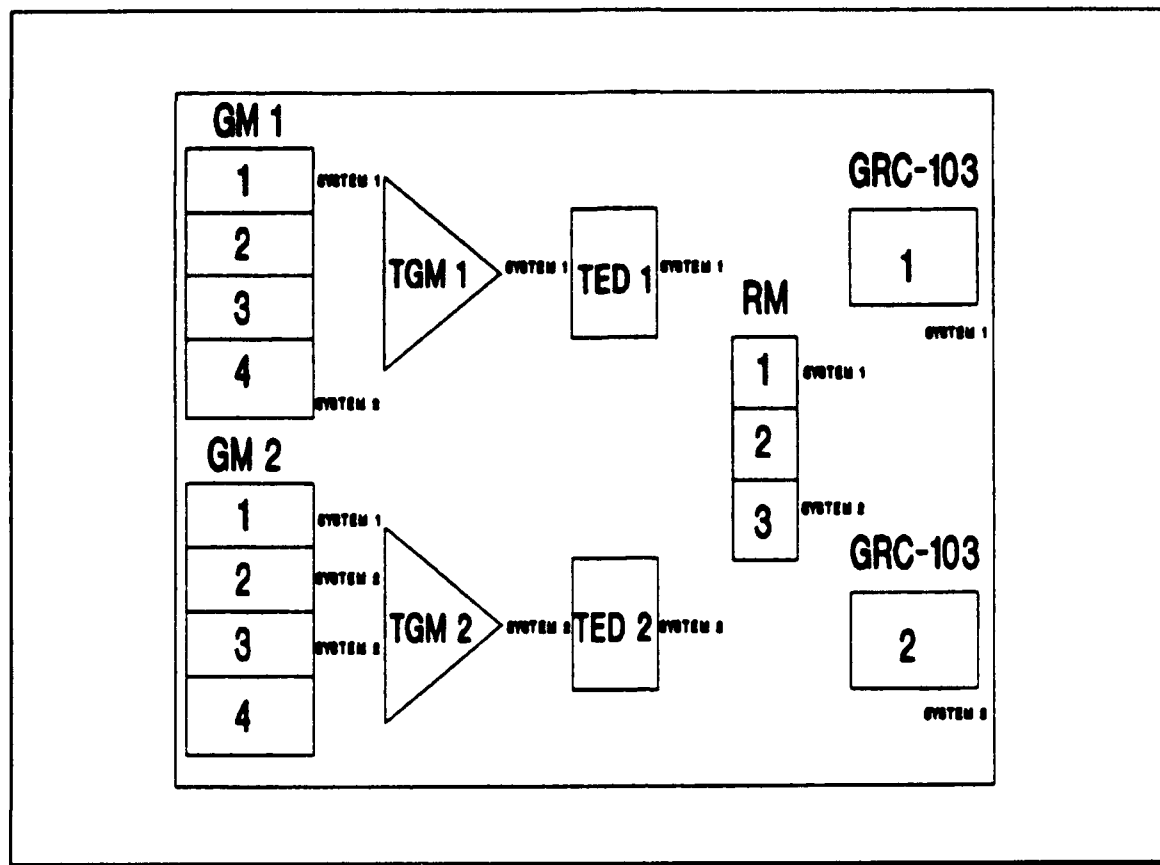

Figure 19: TRC-173 In-System Component Labeling

C. TRC-173 STATUS MESSAGE SEGMENT DESIGN

This portion of the thesis discusses the design of the TRC-173 Status Message Segment which is divided into three sections. The first section is the Network Model Database Design. This database represents the network model described in Chapter II and maintains the network status. The next section presents the design of the TRC-173 Status Message Structure. The third section provides the Status Message Processing Logic Design.

1. Network Model Database Design

The Network Model Database is used to maintain the network connectivity, equipment, and status. This database is divided into three sections. The first section defines each item in the network and maintains its status. The database schemas which fall into this section are: Basic Equipment, TRC-173 Components, and Item Status. The second section maintains the connectivity information between equipment. The database schemas which fall into this section are: GRC-103 Radio Unit to Radio Link Mapping, GM Slot to Cable Link Mapping, and Equipment Item to Cable Link Mapping. The final section maintains the information about which links transmit which digital transmission groups. The digital transmission group to Link Mapping Schema makes up this section.

a. Item Definition and Status Maintenance Schemas

(1) **Basic Equipment Schema.** The Basic Equipment Schema is used to define and maintain the status for the end item equipment utilized in the network. In this network model there are three types of end item equipment, TRC-173s, TTC-39D circuit switches, and Remote Multiplexer Combiners. The Unit_Id attribute is used to maintain the Army unit's designation that owns the end item equipment. The Node_Id attribute is used to identify the node that the equipment is assigned. The Equipment_Id attribute is utilized to identify the end item equipment at the nodal level. The Unit_Id, Node_Id, and Equipment_Id make up the key attributes for this schema. The Equipment_Type attribute maintains the end item equipment's type. The Status_Stack attribute is a stack data structure that maintains the equipment's status. The top element in the Status_Stack contains the equipment's current status. Each element in the stack has a Status and Message_Id attribute. Only red status values with their associated status message number will be stacked. When the Status_Stack is free of red status values non-red statuses can be stored in the top stack position. Initially the Status_Stack value is green.

(2) **TRC-173 Components Schema.** The TRC-173 Components Schema is used to maintain the status and in-system state of the components for each TRC-173 in

the network. The Unit_Id, Node_Id, and Equipment_Id attributes have the same meaning as stated above. Each stand alone component (TED_1, TED_2, GRC_103_1, GRC_103_2, TGM_1, and TGM_2) or component slot (RM_1, RM_2, RM_3, GM_1_1, GM_1_2, GM_1_3, GM_1_4, GM_2_1, GM_2_2, GM_2_3, and GM_2_4) is a composite attribute consisting of the following attributes: Status and System_Number. The Status attribute contains the component's status. Initially Status has a value of green. The System_Number attribute represents which internal system path the component belongs to. The System_Number value can be 0 (meaning not in-system), 1 (meaning in-system and supporting internal system path 1), or 2 (meaning In_system and supporting internal system path 2). Each end item component that contains component slots (RM, GM_1, and GM_2) is a composite attribute consisting of the Status attribute. The Status attribute contains the end item component's overall status.

(3) Item Status Schema. This schema is used to define and maintain the status of radio links, cable links, and digital transmission groups. The Node_Id attribute has the same meaning as stated above. The Item_Id attribute is used to identify the item (radio link, cable link, or digital transmission group) at the nodal and internodal levels. The Node_Id and Item_Id make up the key attributes for this schema and together identify the item at the network, nodal, and internodal levels. The Status_Stack attribute provides the same function as stated above.

b. Connectivity Schemas

(1) GRC-103 Radio Unit to Radio Link Mapping Schema. The GRC-103 Radio Unit to Radio Link Mapping Schema is used to maintain which radio units are mapped to a particular radio link. The Unit_Id, Node_Id, and Equipment_Id attributes have the same meaning as stated above. The Radio_Id attribute is used to identify a specific TRC-173's radio unit. The Unit_ID, Node_Id, Equipment_Id, and Radio_Id make up the key attributes for identifying a particular radio unit. The Radio_Link_Node_Id attribute identifies the node that is responsible for maintaining the radio link. The Radio_Link_ID

attribute is used to identify the link. The Radio_Link_Node_Id and Radio_Link_Id attributes make up the key attributes for identifying a particular radio link at the network, nodal, and internodal levels.

(2) GM Slot to Cable Link Mapping Schema. This schema is used to maintain which GM slots are mapped to a particular cable link. The Unit_Id, Node_Id, and Equipment_Id attributes have the same meaning as stated above. The GM_Slot_Id attribute is used to identify a GM slot. The Unit_ID, Node_Id, Equipment_Id, and GM_Slot_Id attributes make up the key attributes for identifying a particular GM slot that is mapped to a cable link. The Cable_Link_Node_Id attribute identifies the node that is responsible for maintaining the cable link. The Cable_Link_ID attribute is used to identify the link. The Cable_Link_Node_Id and Cable_Link_Node_Id attributes make up the key attributes for identifying a particular cable link at the nodal and internodal levels.

(3) The Equipment to Cable Link Mapping Schema. The Equipment to Cable Link Mapping Schema is used to maintain which cable links are mapped to a particular TTC-39D circuit switch or Remote Multiplexer Combiner. The Unit_Id, Node_Id, and Equipment_Id attributes make up the key attributes for identifying the equipment that is mapped to a cable link at the nodal or internodal levels. The Cable_Link_Node_Id and Cable_Link_Id attributes make up the key attributes for identifying a cable link at the nodal and internodal levels.

c. DTG to Link Mapping Schema

This schema is used to maintain which digital transmission groups are mapped to a radio or cable link. The Link_Node_Id and Link_Id attributes make up the key. This key is used to identify a particular radio or cable link at the network, nodal, or internodal levels. The DTG_Node_Id and DTG_Id attributes make up the key attributes for identifying a particular digital transmission group at the network, nodal, and internodal levels.

2. TRC-173 Status Message Status Message Structure

The TRC-173 Status Message contains a TRC-173 component's status change. The Unit_Id, Node_Id, and Equipment_Id attributes are used to identify a specific TRC-173. The Component_Id attribute identifies the component that has had its status changed. The Status attribute maintains the component's new status value. The System_Number attribute contains the in-system state of the component. The Message_Id attribute contains a number used to identify the status message. Red status messages and their corresponding green messages will both have the same unique message number.

3. TRC-173 Status Message Processing Logic Design

Upon receipt of a status message, the status message processing module evaluates the status message's component status and in-system state. The status message is then forwarded to one of the following sub-modules for further processing: Component Red and In-system, Component Green and In-system, Component Red and Not In-system, and Component Green or Not In-system (see Figure 20). The algorithms for these sub-modules are contained in Appendix C.

D. SYSTEM MANAGEMENT CONTROLLER SEGMENT DESIGN

The System Management Controller Segment is responsible for ensuring that both the panel and status message segments communicate properly between each other. This segment structure is based on the Panel Display Object Database and four Ada tasks. The Network Database Processor, Display Object Database Processor, TRC-173 Status Message Receiver, and Display Object Timer make up the four Ada tasks.

1. Panel Display Object Database Design

The Panel Display Object Database maps current status values from the network database to the appropriate panel display object. This database is implemented as an array with various sections representing each display panel. Each array position contains a panel

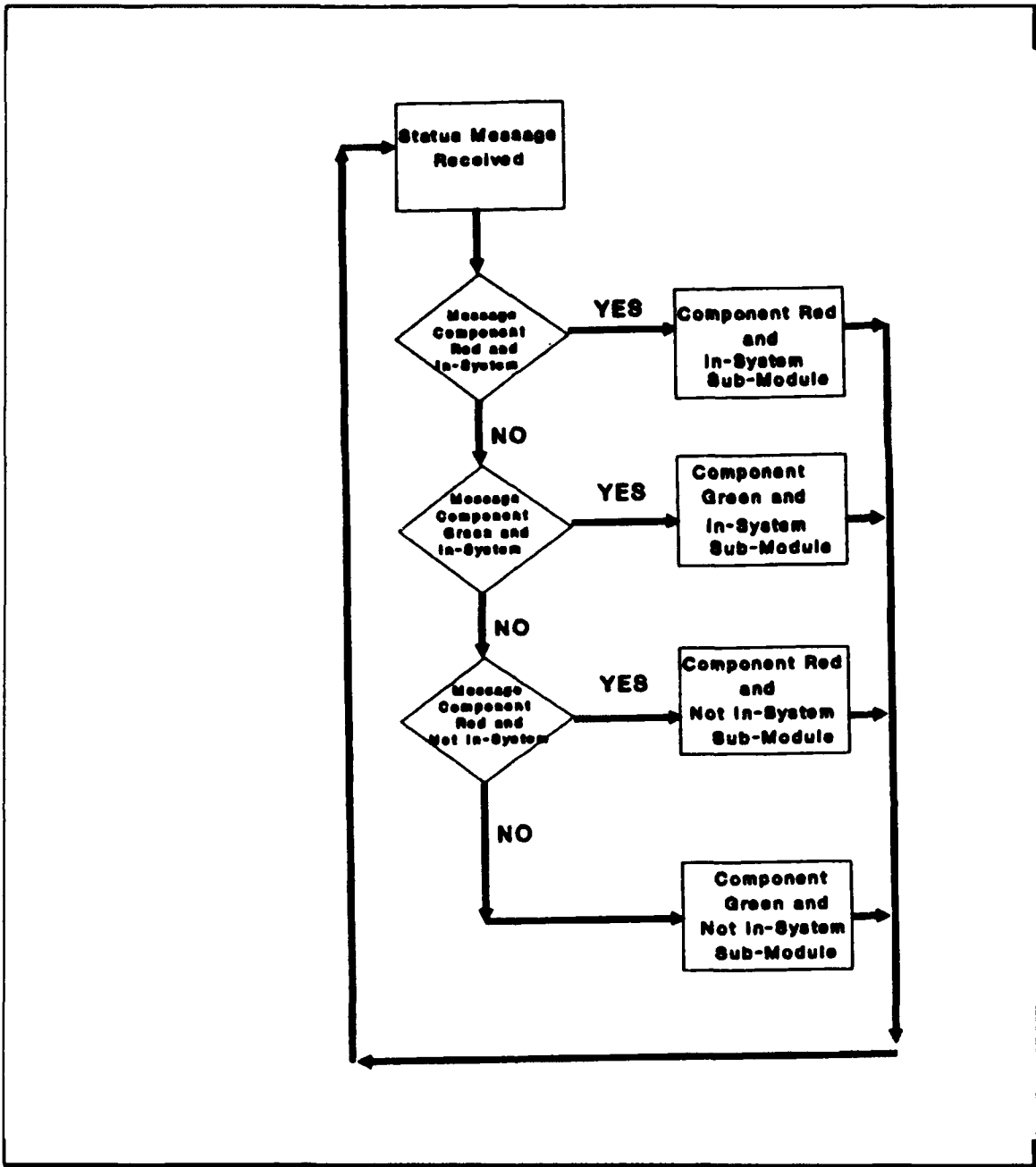

Figure 20: Message Processing Data Flow

display object and its current status value. Figure 21 displays the structure of the database and the position ranges per display panel.

The Panel Display Object Database Schema is used to maintain the mapping data between the network database and display objects. The Panel_Name and Item_In_Panel

1	TRC-173 Components Panel
37	
38	Network Level Panel
43	
44	Node 1 Level Panel
66	
67	Node 2 Level Panel
89	
90	Node 3 Level Panel
112	
113	Internodal L12 Level Panel
119	
120	Internodal L23 Level Panel
126	
127	Internodal L31 Level Panel
133	

Figure 21: Display Object Database Panel Ranges

attributes refers to a particular display item in a display panel. The Unit_Id, Node_Id, and Item_Id attributes refer to a specific element in the network database, i.e., equipment or a link. The System_Number attribute is used only with the TRC-173 section. Its purpose is to identify whether a component is in-system (SYSTEM 1 or SYSTEM 2) or not in-system.

The Status attribute contains the same status value for a display object. Initially the Status value is green. The Blink attribute contains a boolean value indicating a display object's blink state. Initially the Blink value is set to false (a nonblinking state).

The TRC-173 line-of-sight radio shelter section of the database is only updated when a user clicks a TRC-173 button. The associated TRC-173 button's TRC-173 Component tuple is read into this section of the display object database. This action causes the appropriate TRC-173's component status to be displayed.

2. Network Database Processor Task

The Network Database Processor Task is responsible for controlling all access to the Network Database. This task has the following two entry points:

a. Status Message Processor Entry Point

This entry point receives a TRC-173 Status Message and passes the message to the TRC-173 Status Message Processing Logic for processing.

b. Read Specific TRC-173 Components Entry Point

This entry point receives a request after a specific TRC-173 button has been clicked to read the specified tuple from the TRC-173 Components Relation. A task entry call is made to the Display Object Database Processor Task to update the Display Object Database's TRC-173 section with the just read component information. After the tuple is read, all Blink attributes of the tuple are set to false.

3. Display Object Database Processor Task

This task is responsible for controlling all access to the Display Object Database. This task has the following four entry points:

a. Update TRC-173 Section Entry Point

This entry point receives a tuple from the TRC-173 Components Relation for updating the Display Object Database's TRC-173 section. The call to this entry point will be made immediately after a TRC-173 button is clicked. This requires the

Transportable Applications Environment Plus code to be modified with a call statement that is inserted after the TRC-173 button code statement.

b. Update General Panel Item Entry Point

This entry point receives a status change to a general display object in the display database. A general display object is an object that does not blink. All display objects except the following do not blink: a TRC-173 identified in a status message, nodes, and internodal links at the network and nodal panels. The call to this entry point is made after the object's Status_Stack has been modified. This requires the TRC-173 Status Message Processing Logic code be modified with a call statement after the network object's Status_Stack is updated.

c. Update Panel TTC-39D Item Entry Point

This entry point receives a status change to a TTC-39D circuit switch display object in the display database. A TTC-39D circuit switch status change causes three updates to the database. The first change is at the network panel where the corresponding node display object receives the TTC-39D circuit switch's status value and its Blink attribute is set to true. The final two changes are at the TTC-39D circuit switch's corresponding node and internodal levels. At these two levels the appropriate TTC-39D circuit switch display objects will receive the status change and their Blink attribute is set to false. The call to this entry point is made after the object's Status_Stack has been modified. This requires the TRC-173 Status Message Processing Logic code to be modified with a call statement to this entry point after the network object's Status_Stack is updated.

d. Update Panel Link Item Entry Point

This entry point receives a status change to a link display object in the display database. An update to a cable or intranodal radio link display object Status attribute causes the associated Blink attribute to be set to false. The update to an internodal radio link causes the corresponding link Status attribute at the network, nodal, and

internodal levels to be assigned the status change. The Blink attribute at the network and nodal level will be set to true. However, the Blink attribute at the internodal level is assigned to false. The call to this entry point is made after the object's Status_Stack has been modified. This requires the TRC-173 Status Message Processing Logic code to be modified with a call statement to this entry point after the network object's Status_Stack is updated.

e. Display Items Entry Call Point

This entry point accepts a signal to refresh the panel display objects with either their status values or to cause them to blink. The Display Object Timer Task will generate this signal.

4. TRC-173 Status Message Receiver Task

This task randomly reads the status message file. The interval between reads can range from one to ten seconds. Once a status message is read it is sent to the Network Database Processor Task_Status Message Processor Entry Point to be processed.

5. Display Object Timer Task

This task sends a signal to the Display Object Database Processor Task_Display Items Entry Point to refresh the panel's display objects. The timing signal is generated every quarter of a second.

IV. MANAGEMENT SYSTEM VALIDATION TEST

Validation testing is a procedure used to ensure that a software system functions in a manner that is consistent with the system requirements.[Ref. 13] This chapter discusses the validation test procedure that was utilized to evaluate the implemented Army Tactical Telephone Network Management System design and provides a summary of the test results.

A. MANAGEMENT SYSTEM VALIDATION TEST PROCEDURE

The Army Tactical Telephone Network Management System validation test consists of the following three steps: constructing and evaluating TRC-173 data sets; processing the data set and collecting the results; and comparing the predicted results against the actual results. The remainder of this section will expound on these steps.

1. Step 1: Constructing and Evaluating TRC-173 Data Set

The first stage in this step is to construct TRC-173 data sets. A data set consists of one or more TRC-173 status messages. These status messages must comply with the message structure that is explained in Chapter III. Each message is based on the network model contained in Chapter II and Appendix B.

After each data set is compiled, the effect of each message on the network is calculated. The calculations are performed in accordance with the network management system reaction requirements contained in Chapter II. By using these system requirements, each status message will affect the network in some or all of the following categories: TRC-173 not in-system component, TRC 173 internal in-system component, TRC-173 external in-system, nodal status message propagation, internodal status propagation, and network status propagation.

2. Step 2: Processing The Data Sets and Collecting The Results

This step requires that the management system be executed with the data sets from step 1. While each status message is processed the corresponding system reactions are recorded.

3. Step 3: Comparing The Predicted Against Actual Results

The predicted results from step 1 are compared against the actual results from step 2. If the results match, then the implemented system complies with its system requirements.

B. SUMMARY OF TEST RESULTS

Five data sets are used to validate the Army Tactical Telephone Network Management System. These five data sets are placed into the following test categories: nodal, internodal, and network.

The nodal test category requires that each node level be tested separately. In each data set, all TRC-173 line-of-sight radio shelters (except for TRC-173s that support internodal links) have at least one red status message and one green status message. The purpose of this test category is to ensure that the individual display items at each nodal level reacts correctly to a TRC-173 generated status message.

In the internodal test category, all TRC-173s that support internodal links are jointly tested. The data set contains at least one red and green status message for each TRC-173. The test objective is to determine whether the internodal display objects are reacting correctly to a status message.

The network test category integrates the testing of all nodal and internodal categories. The data set contains at least one red and green status message for each TRC-173. The purpose of this test category is to demonstrate that the management system functions correctly with processing both nodal and internodal levels status messages.

The results of the validation test using the three test categories are that each data test set's predicted results matched their corresponding actual results. Therefore, the

implemented Army Tactical Telephone Network Management System complies with its system requirements.

V. CONCLUSIONS AND RECOMMENDATIONS

A. CONCLUSIONS

This thesis presents a design for an automated real-time panel-driven Army Tactical Telephone Network Management System. The design is implemented in Ada and utilizes the Transportable Applications Environment Plus interactive graphical user interface tool. The network management system monitors a fixed network and updates the network's status through TRC-173 status messages. Validation testing is used to demonstrate that the program conforms to its system requirements.

This management system illustrates that from a central location, communication commanders can receive real-time network status updates down to the line-of-sight radio shelter component level. This capability is not currently available to these commanders. Without this capability, communication commanders will not have a rapid and efficient tool for identifying and diagnosing network outages.

A copy of the Army Tactical Telephone Network Management System program listing is available by request from the Computer Science Department, Naval Postgraduate School. This request can be sent by electronic mail to lundy@taurus.cs.nps.navy.mil or postal mail to Dr. G. M. Lundy, Code CS/Ln, Assistant Professor, Computer Science Department, Naval Postgraduate School, Monterey, CA 93943-5000.

B. RECOMMENDATIONS FOR FURTHER RESEARCH

The Army Tactical Telephone Network Management System should be expanded to handle the monitoring of all equipment in the Area Common User System. This will require implementing status messages for each type of equipment and incorporating their network reaction requirements to the management system.

The Army Tactical Telephone Network Management System utilized an array data structure to implement the `Status_Stack` attribute. This data structure is a wasteful utilization of memory space and is limited to supporting 35 stacked red status. In order improve efficiency, the stack should be implemented in a dynamic data structure.

The network database should be modified to enable the system to receive and process equipment operation level messages. This function could enable the tracking of equipment operation levels. It could also notify the user when equipment is approaching a nonoperable status. This function would allow the network monitor to take proactive steps to prevent network degradation.

The network database is an array. The database should be implemented with a database management system. This will allow the user to query the database for trends at the network or a specified unit level, to determine equipment availability and location, and user specified areas of interest.

The implemented Army Tactical Telephone Network Management System has limited error handling for erroneous status messages. In order for this network management system to be operationally utilized, it must be able to recognize erroneous status messages.

A "logic box" must be developed that will determine the equipment status and transmit the status message to the Army Tactical Telephone Network Management System for processing. The issues of message propagation delay and message signaling method must be addressed.

APPENDIX A: ACRONYMS AND DEFINITIONS

ACUS: Area Common User System- is the U.S. Army's battlefield telephone network.

AN/TRC-173: is one of the U.S. Army's radio communications shelters. This type of shelter utilizes the line-of sight communications technique.

AN/TTC-39: is the U.S. Army's base series circuit switch that is used at the echelons above corps level.

AN/TTC-39D: is a specific AN/TTC-39 model that uses floor search routing.

CCITT: International Consultative Committee on Telegraphy and Telephony

Corps- contains from three to five divisions and its command structure and support elements operate behind the division areas. A corps, including its divisions, can contain more than 80,000 troops and operates in an area of 35,000 square km.

CS: circuit switch- is a communications device that establishes a dedicated path between any pair or group of users attempting to communicate.

Division- is the most forward combat element (between a division and corps) and consists of approximately 15,000 troops. The area that a division can cover is approximately 4000 square km.

DTG: digital transmission group; refers to a collection of full duplex channel. These channels can be trunks, telephone loops, or data loops.

GM: Group MODEM- converts a cable link signal to a nonreturn to zero (NRZ) signal and a NRZ signal into either conditioned diphase, dipulse, or bipolar signal.

km: kilometers

kbps: kilobits per seconds.

LOS: line-of-sight- is a communication technique that requires the transmitted signal to travel in a narrow beam to the receiver.

MSRT: Mobile Subscriber Radiotelephone Terminal: is a device that provides a mobile user access to the RAU.

NRZ: nonreturn to zero- is a digital signaling technique in which the signal is a constant level for the duration of a bit time.

RAU: Radio Access Unit - is part of the U.S. Army's cellular telephone system. This device provides a mobile user access to the ACUS.

RM: Radio MODEM- converts a NRZ signal from the to a radio binary signal and a radio binary signal into a NRZ signal.

RMC: Remote Multiplexer Combiner- is a device that multiplexes and demultiplexes up to eight full duplex telephone loops.

TED: Trunk Encryption Device- can be connected to each TGM to encrypt and decrypt the signals passing through it.

TGM: Trunk Group Multiplexer- can multiplex and demultiplex up to four NRZ signals from a Group MODEM

Theater- is a geographical area that is outside of the Continental United States which has been assigned a unified or specified military commander. The geographic size of a theater can easily exceed 1,000,000 square km. When US military power is required the theater assets are geographically focused against the opposing force. The theater is divided into two levels: echelons corps and below and echelons above corps. The echelons corps and below portion of the theater is where the actual combat operations are conducted and is composed of divisions and corps. The echelons above corps portion of the theater is the area rearward of combat operations and provides support for the entire theater.

X.25- A standard packet switch protocol.

APPENDIX B: NETWORK LAYOUT & INTERNAL CONNECTIVITY

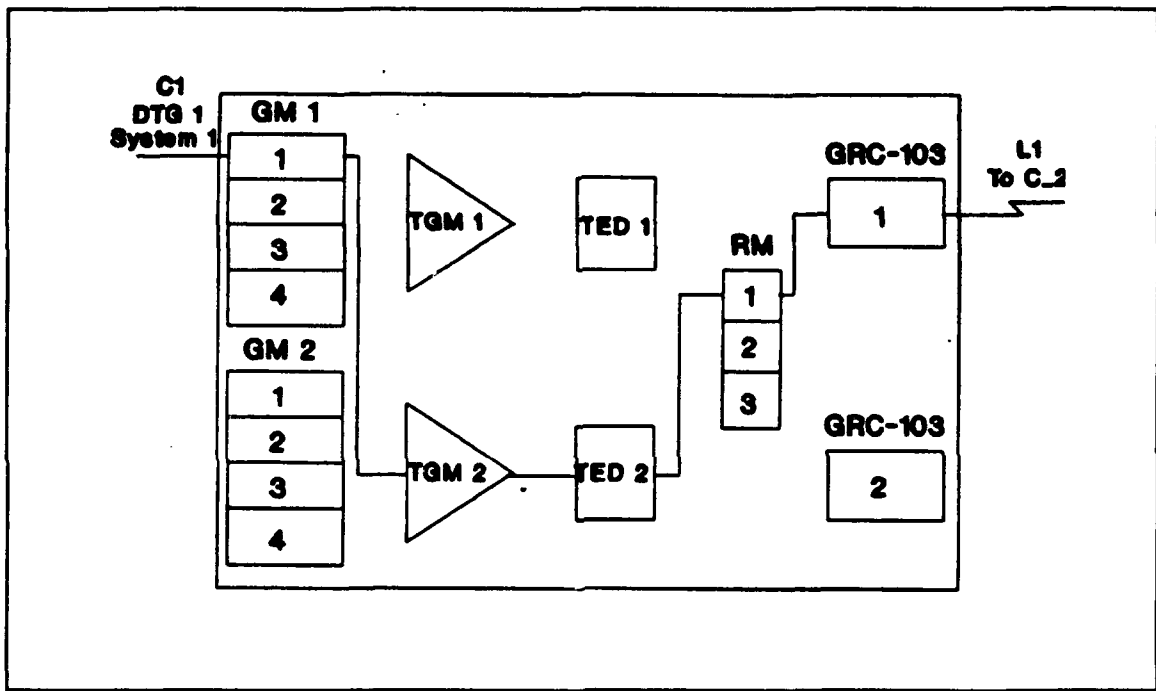

Figure 22: Node 1 C_1 Internal Connectivity

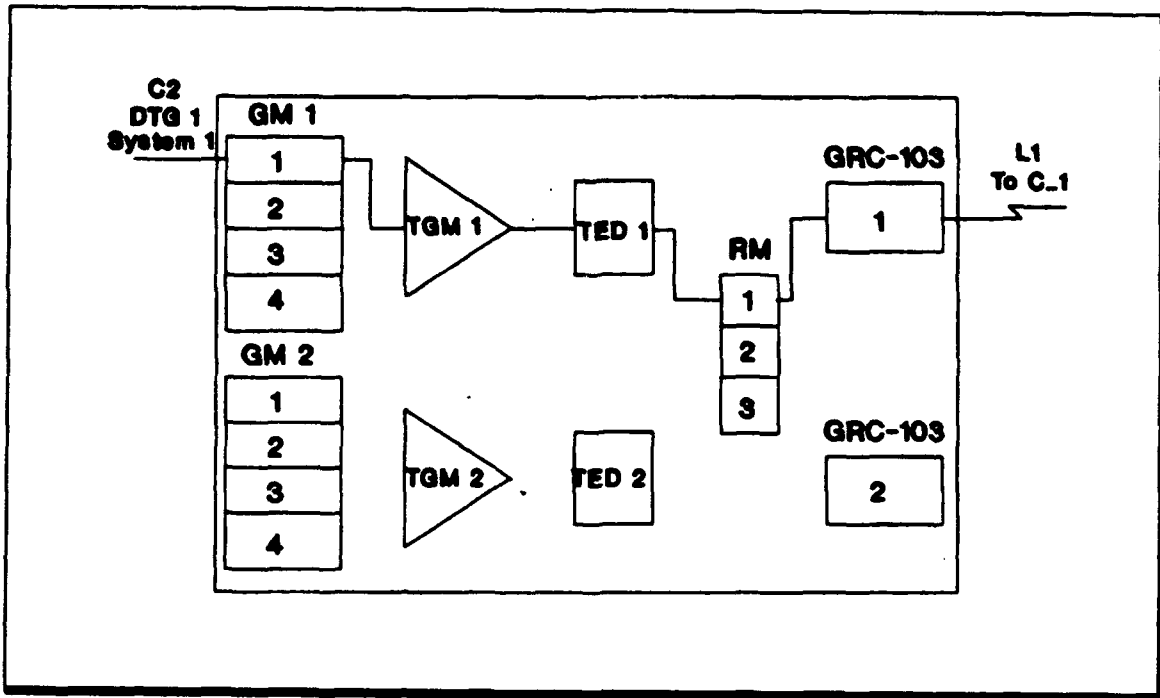

Figure 23: Node 1 C_2 Internal Connectivity

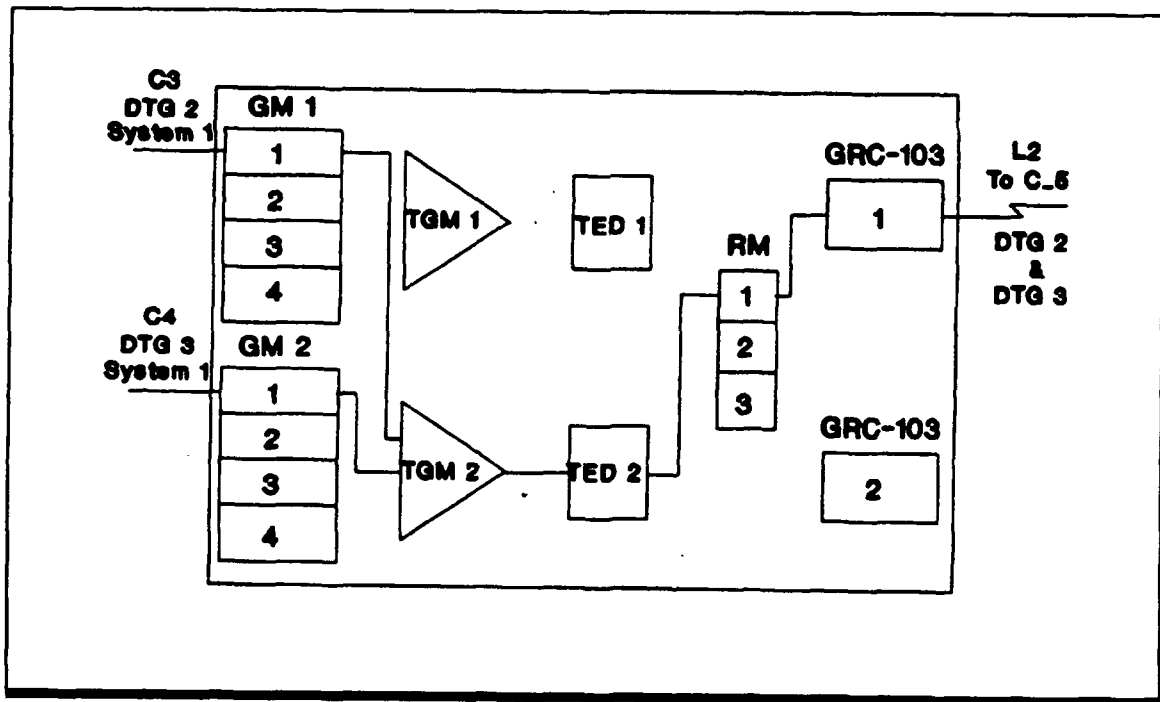

Figure 24: Node 1 C_4 Internal Connectivity

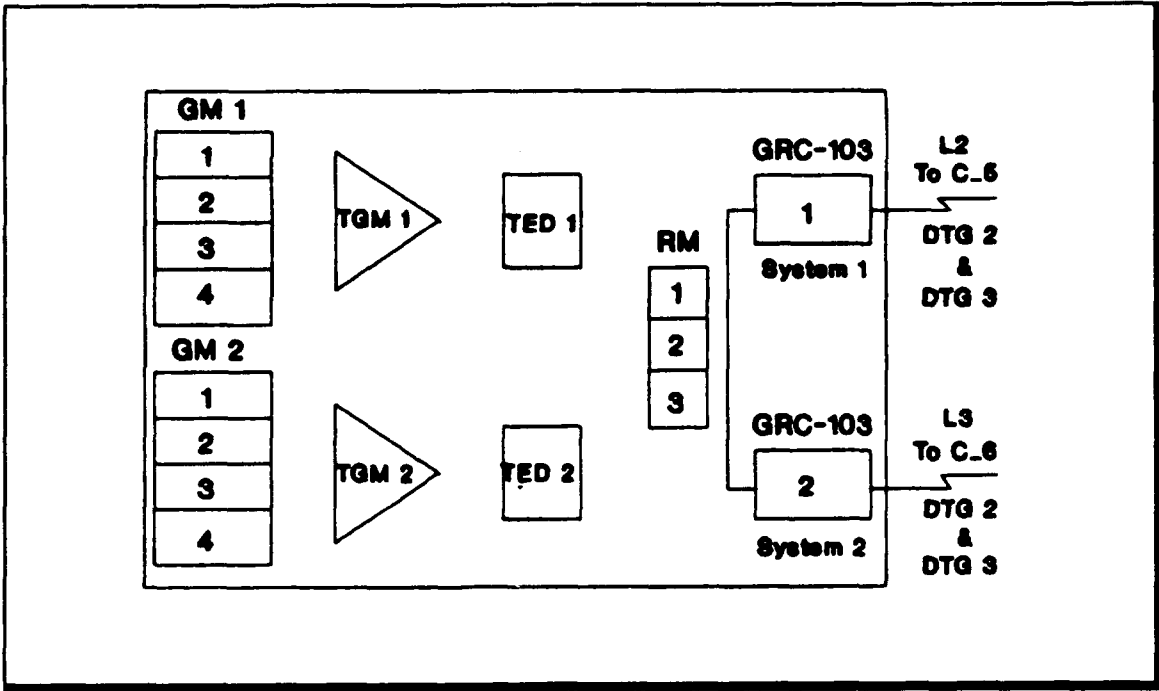

Figure 25: Node 1 C_5 Internal Connectivity

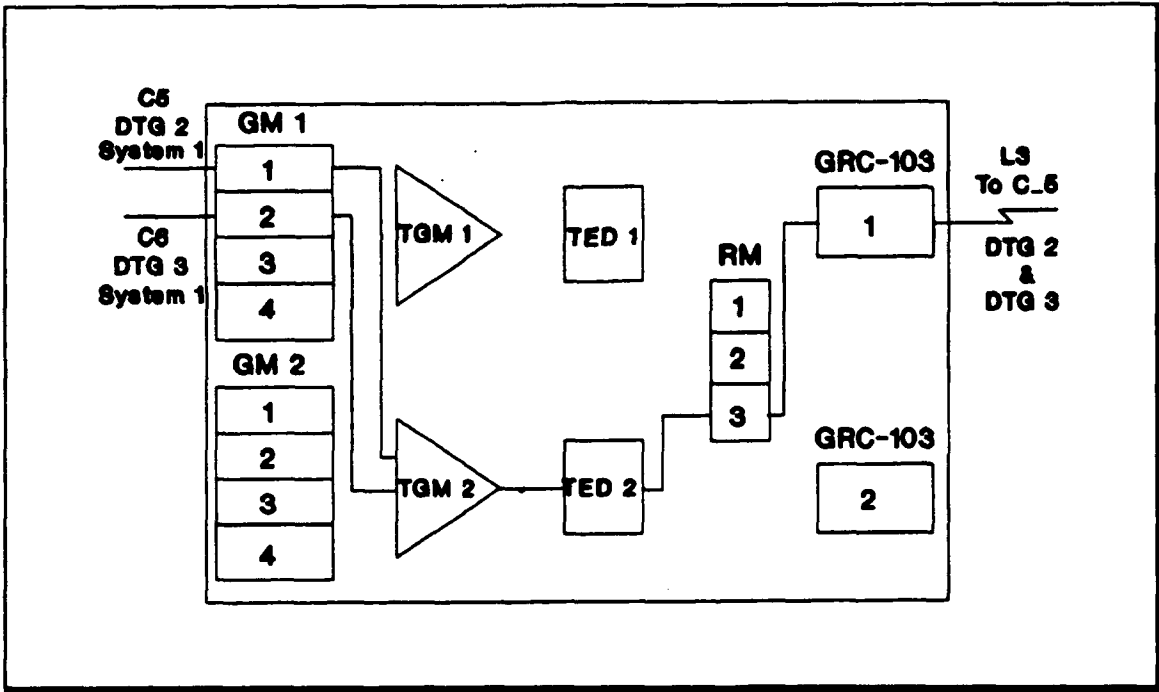

Figure 26: Node 1 C_6 Internal Connectivity

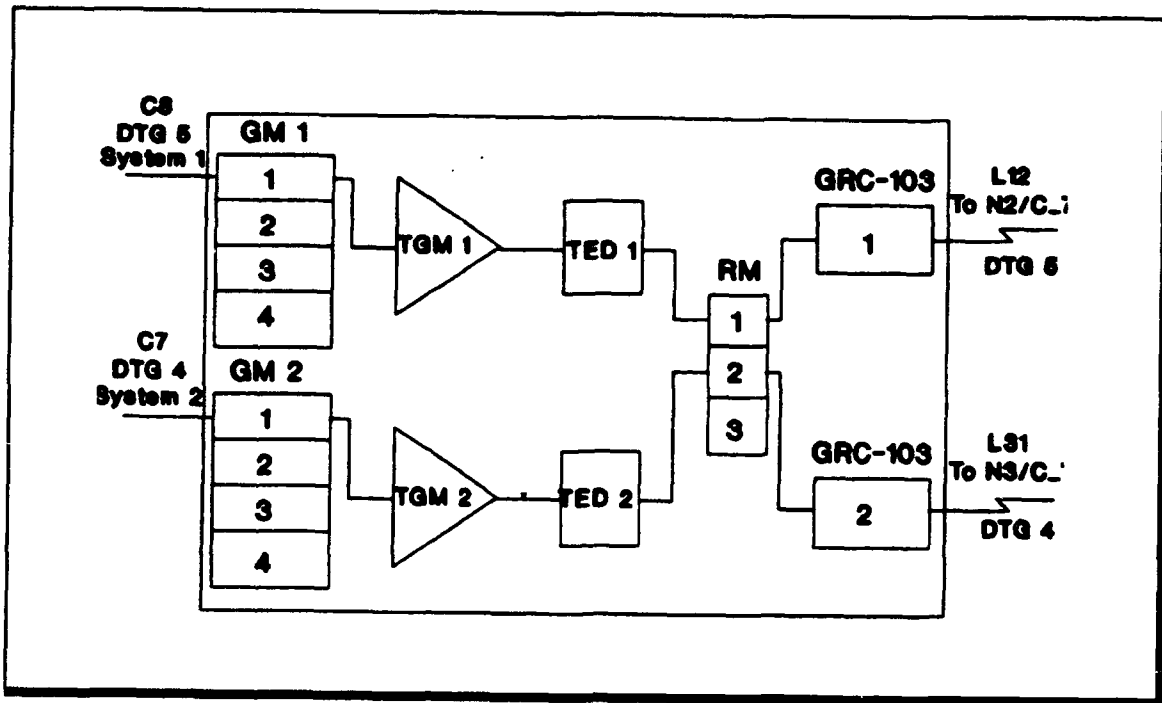

Figure 27: Node 1 C_7 Internal Connectivity

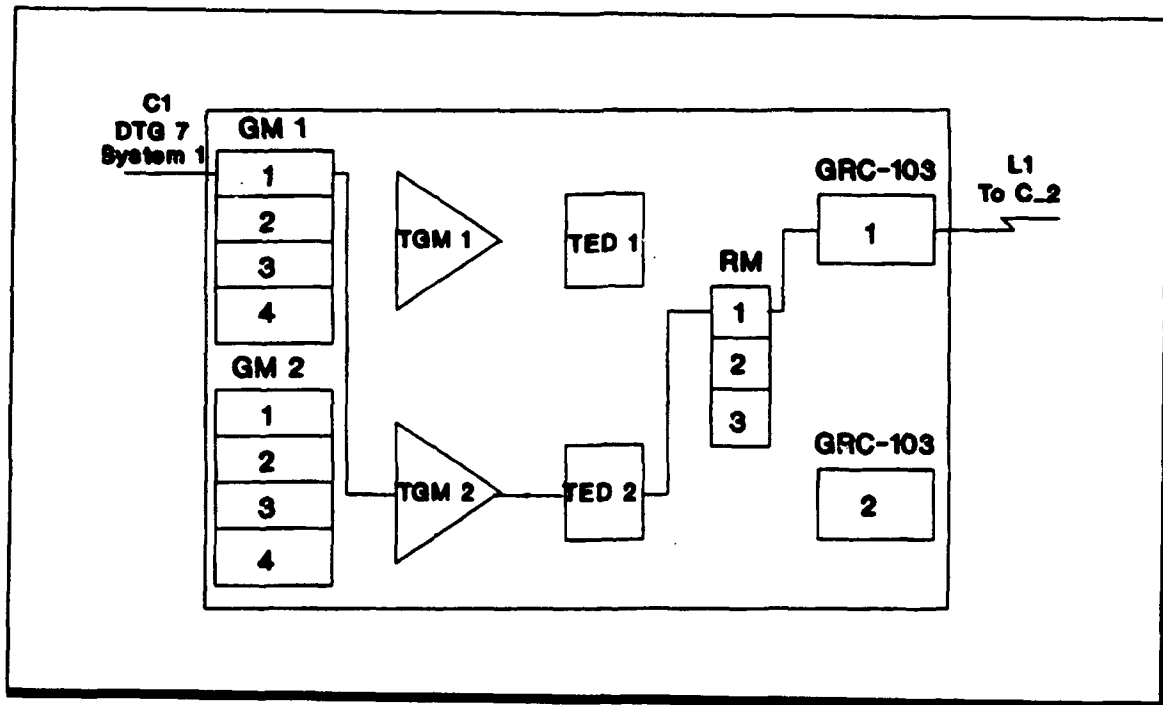

Figure 28: Node 2 C_1 Internal Connectivity

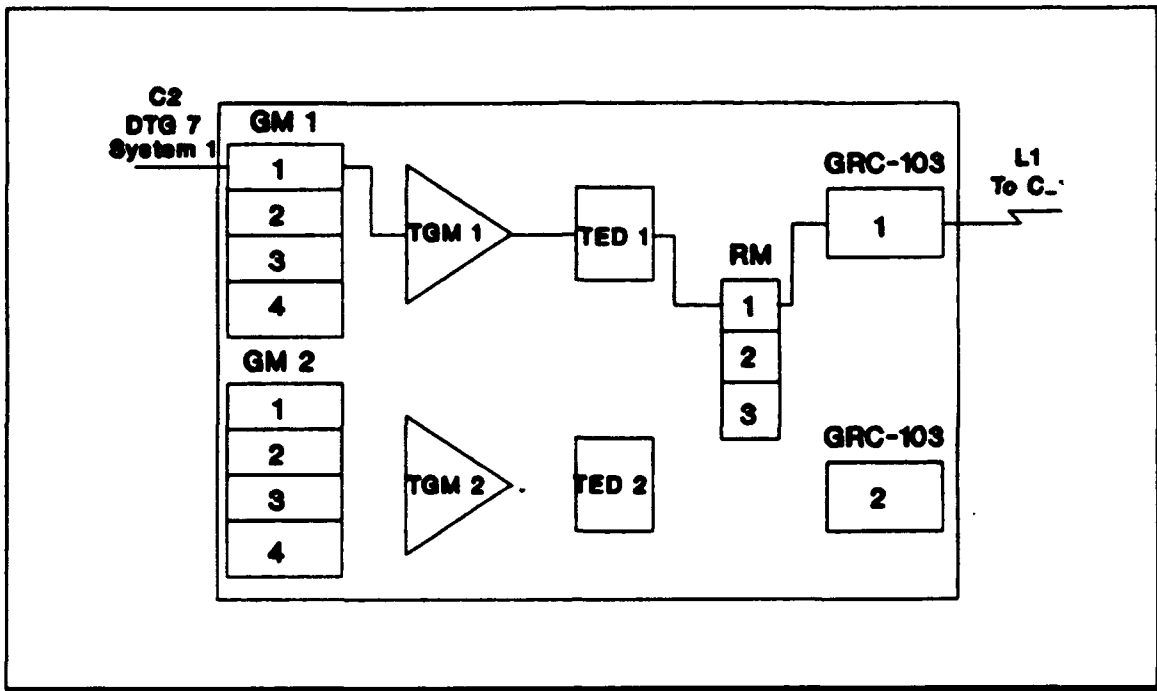

Figure 29: Node 2 C_2 Internal Connectivity

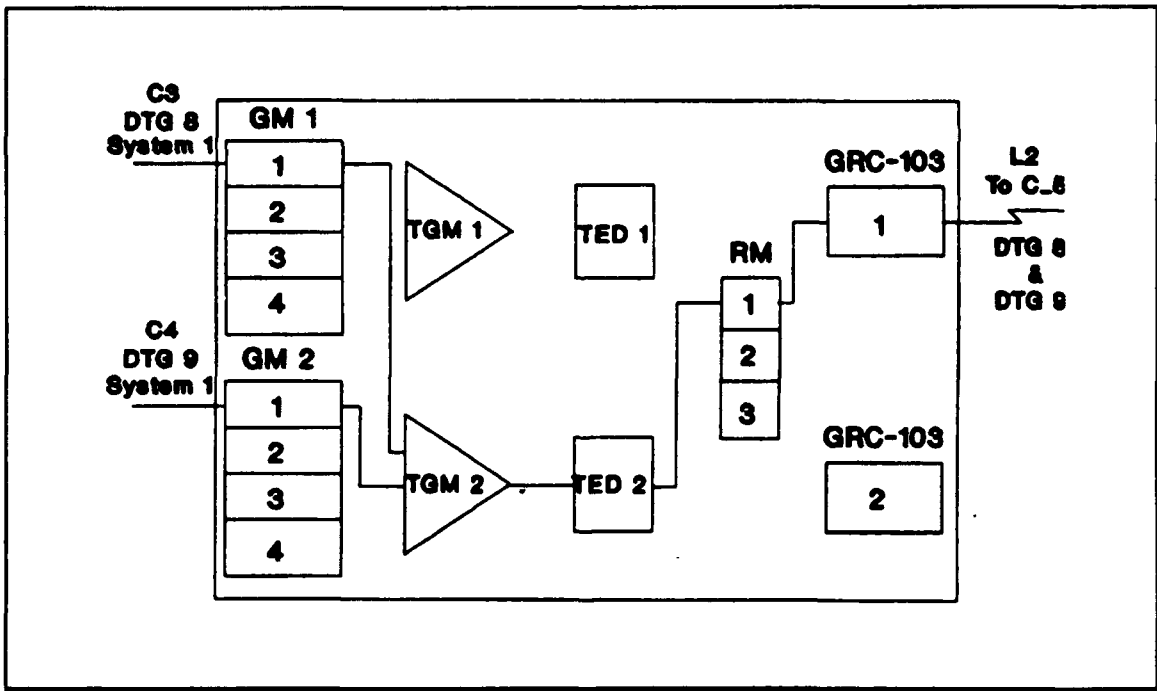

Figure 30: Node 2 C_4 Internal Connectivity

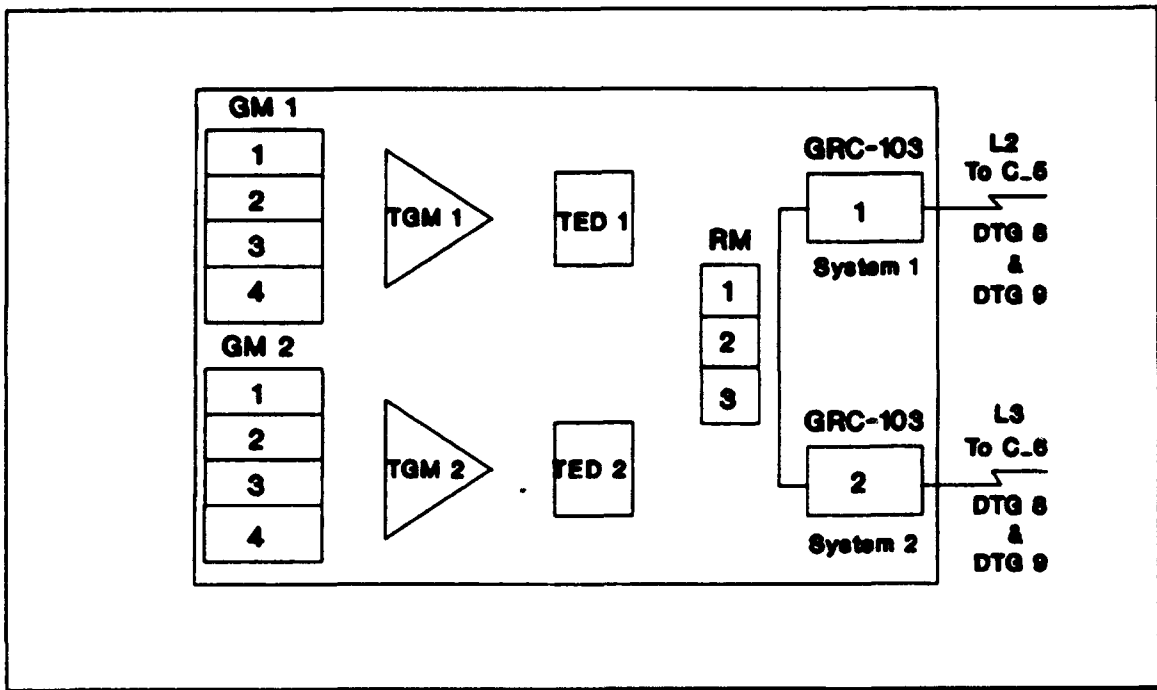

Figure 31: Node 2 C_5 Internal Connectivity

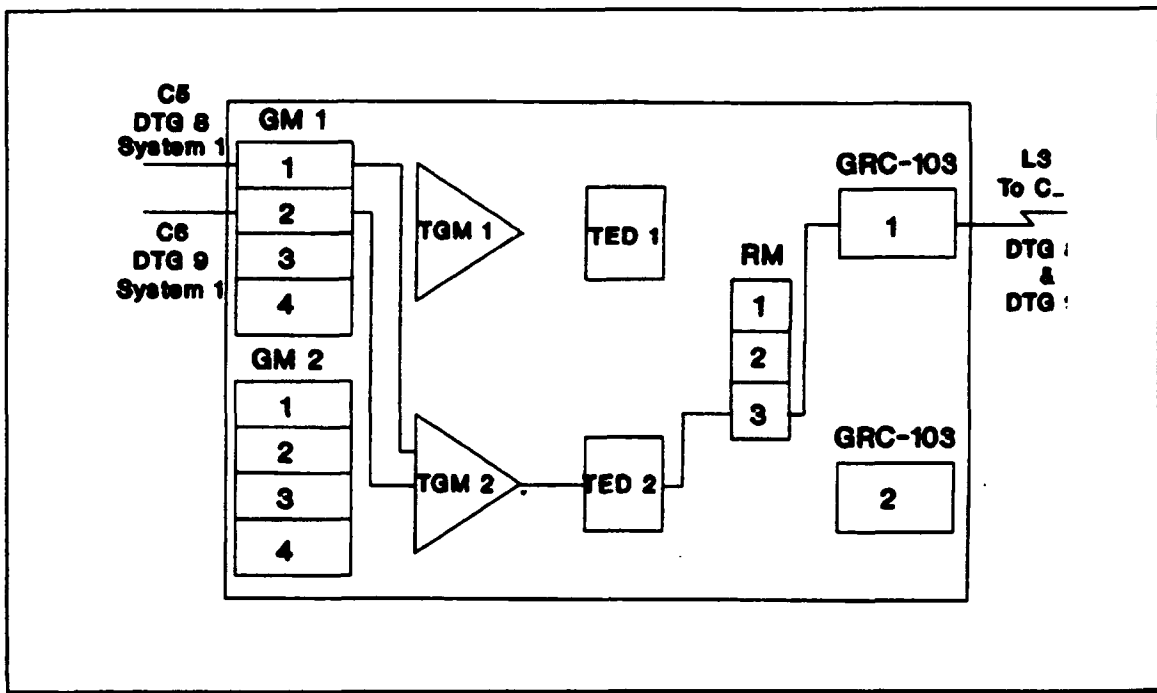

Figure 32: Node 2 C_6 Internal Connectivity

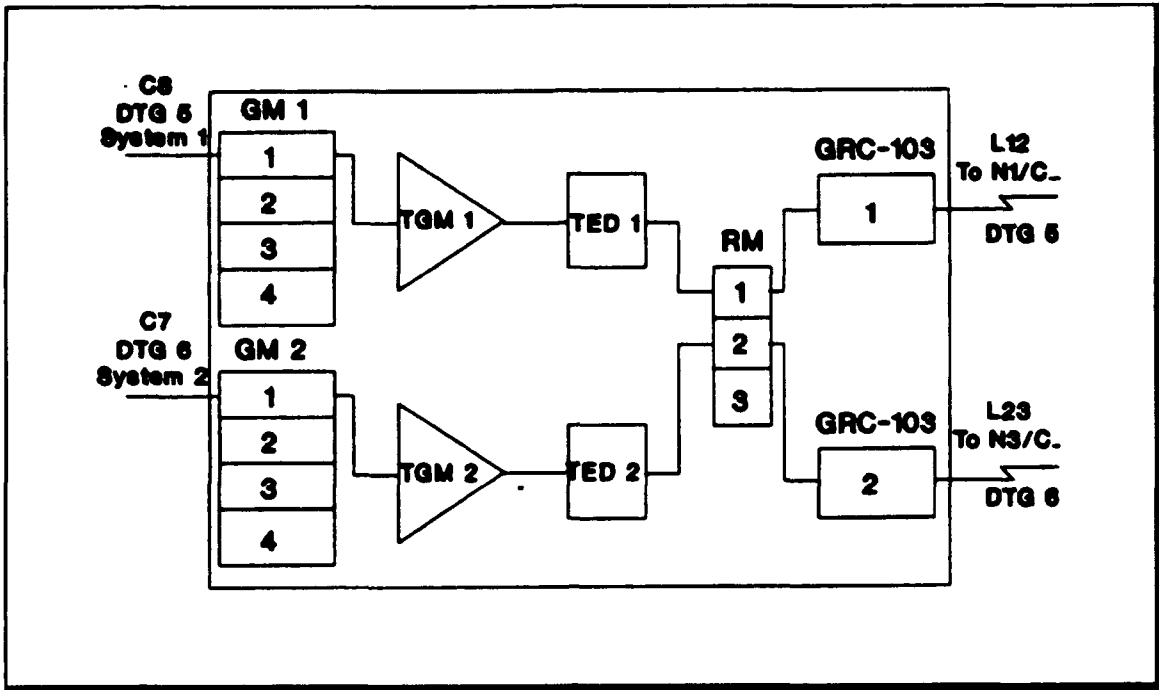

Figure 33: Node2 C_7 Internal Connectivity

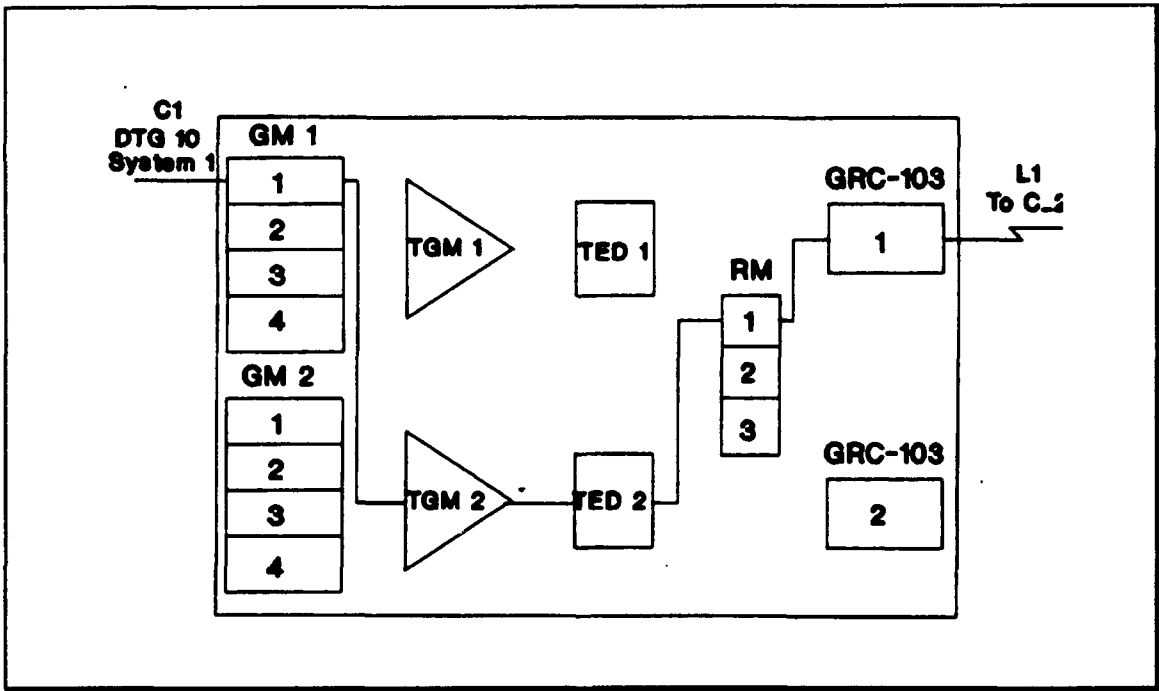

Figure 34: Node 3 C_1 Internal Connectivity

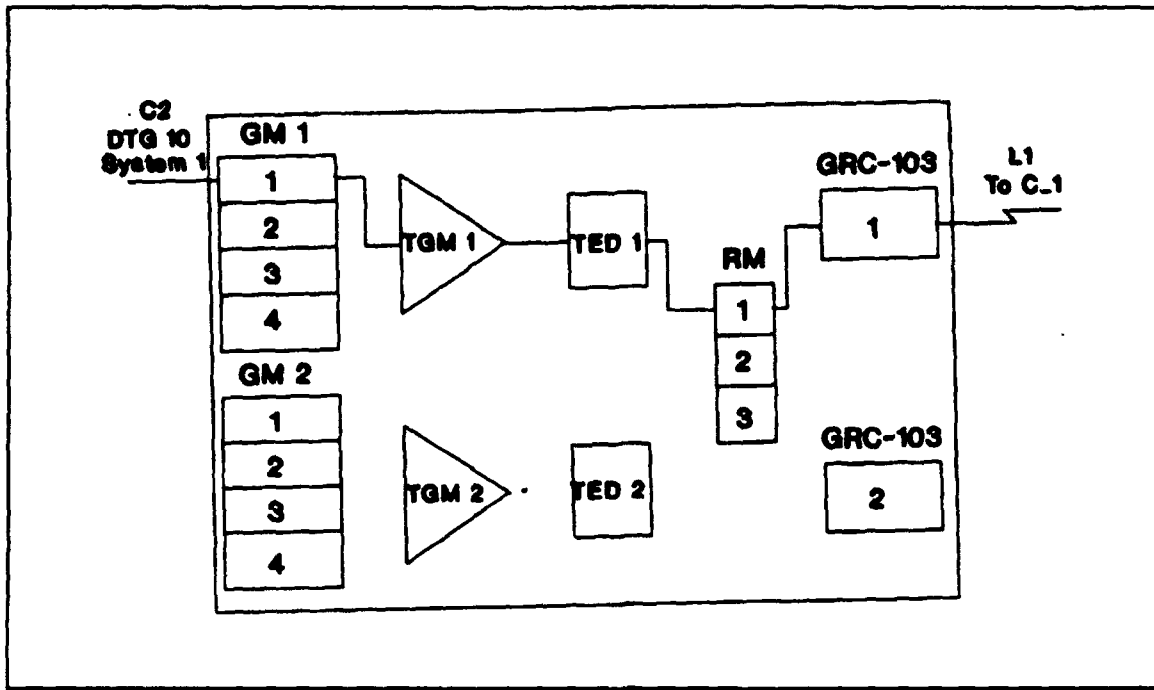

Figure 35: Node 3 C_2 Internal Connectivity

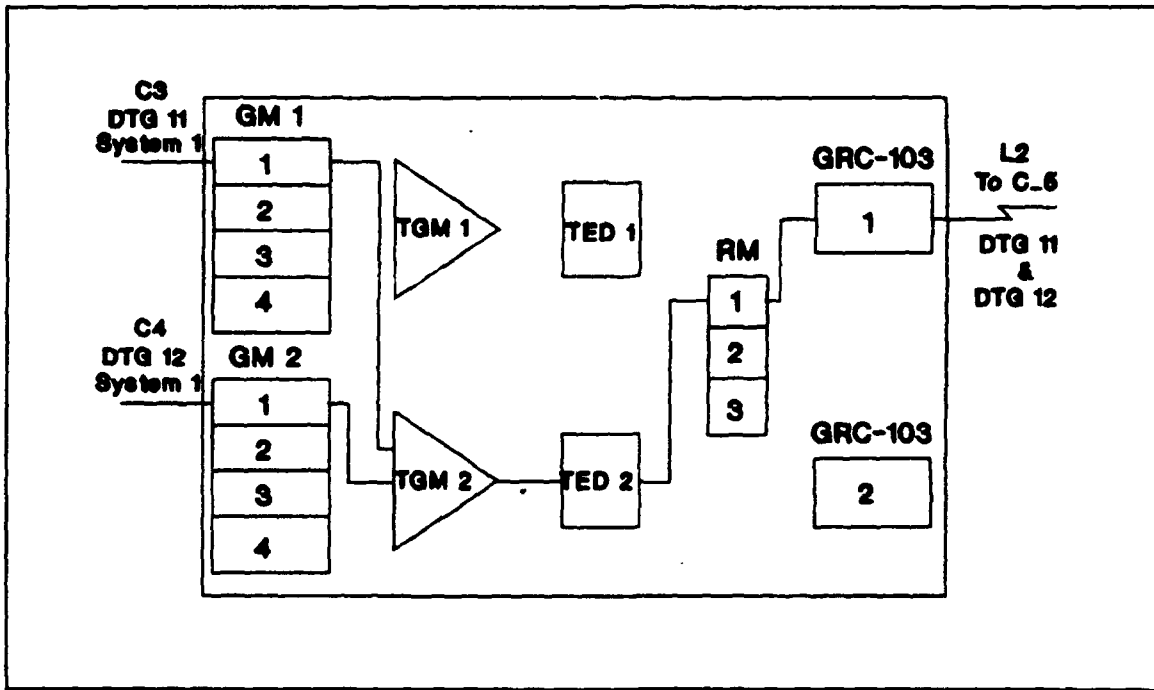

Figure 36: Node 3 C_4 Internal Connectivity

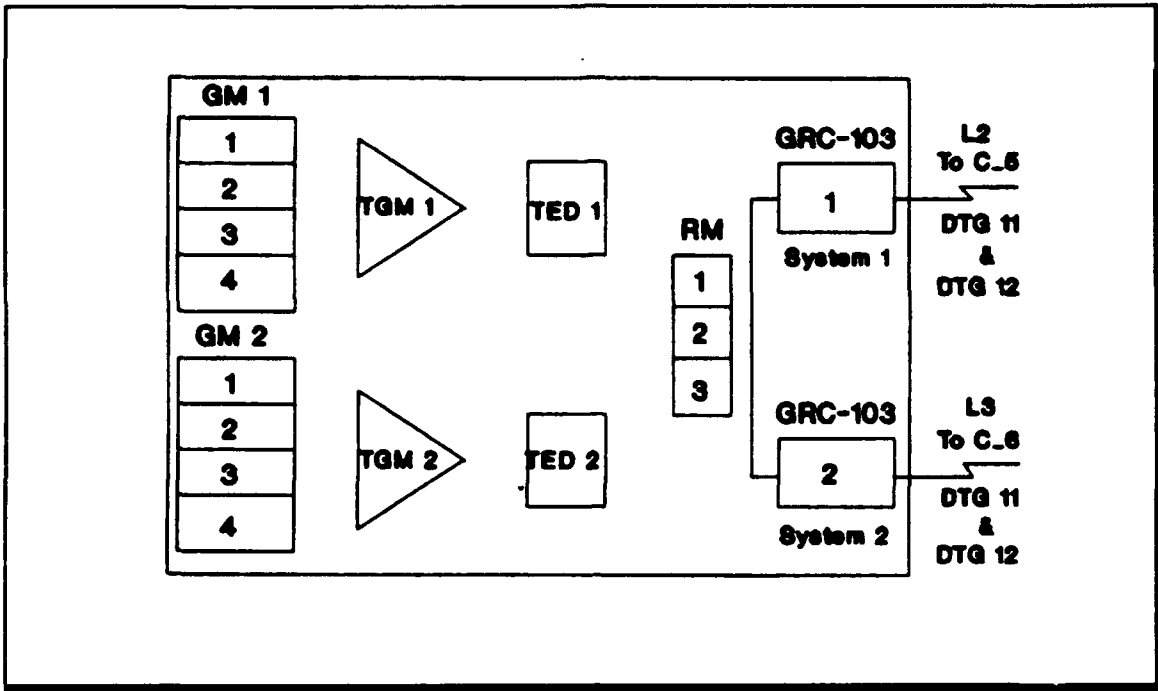

Figure 37: Node 3 C_5 Internal Connectivity

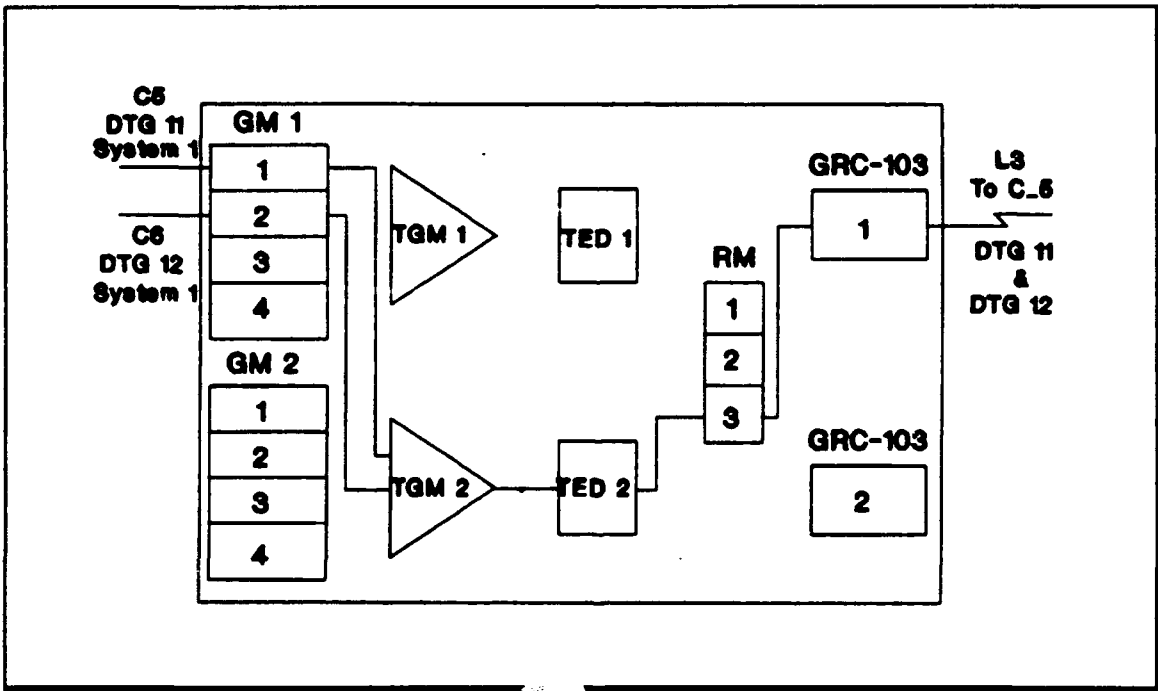

Figure 38: Node 3 C_6 Internal Connectivity

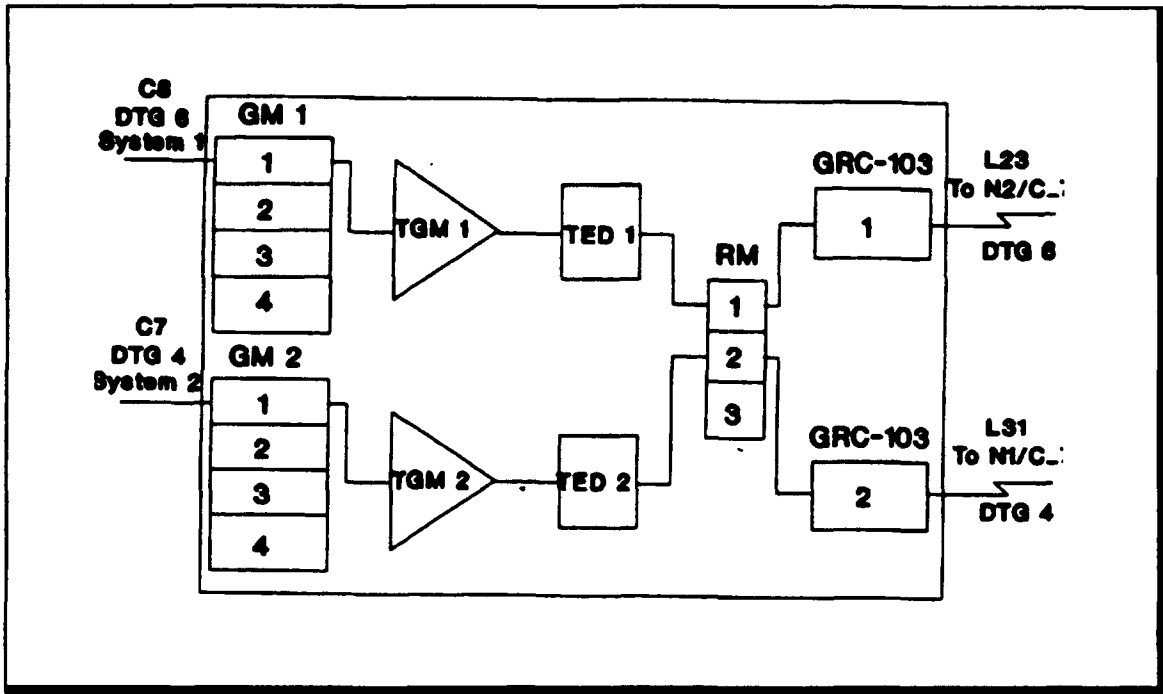

Figure 39: Node 3 C_7 Internal Connectivity

APPENDIX C: ALGORITHMS FOR MESSAGE PROCESSING

A. Red and In-system Sub-module Algorithm Steps

1. Search for a tuple in the TRC-173 Components Relation that matches the Unit_Id, Node_Id, and Equipment_Id attributes in the status message. When the tuple is found change its component (identified in the status message) to the status indicated (in the status message).

2. Check if the remaining components' (that match the component type in the status message) statuses are also red. If true, search for a tuple in the Basic Equipment Relation that matches the Unit_Id, Node_Id, and Equipment_Id attributes in the status message and push a red status with the current Message_Id on the tuple's Status_Stack attribute.

3. If the component in the status message is an internal component then the following are executed:

a) Find the GRC-103, in the tuple from step 1, that has the same System_Number as in the status message.

b) Search for a tuple in the GRC-103 Radio Unit to Radio Link Relation that matches the Unit_id, Node_Id, Equipment_Id, and GRC-103 from step 3.a.

c) Search for the tuples in the DTG to Link (radio links) Mapping Relation that match the Link_Node_Id and Link_Id in step 3.b).

d) Search for the tuples in the Item (DTGs) Status Relation that match the Node_Id and Item_Id in step 3.c) and push a red status with the current Message_Id on the tuples' Status_Stack attribute.

e) Search for the tuples in the DTG to Link (cable links) Mapping Relation that match the DTG_Node_Id and DTG_Id in step 3.d).

f) Search for the tuples in the Item (cable links) Status Relation that match the Node_Id and Item_Id in step 3.e). Next evaluate and assign a new status to each cable link tuple based on TABLE 2.

TABLE 2: CABLE OR RADIO LINK STATUS

Overall Cable Links' Status Is	Oper	Overall Cable Links' Status Is	Then Do The Following To The Status_Stack
Blue	Or	Blue	If No Red Status: Pop & Push Blue Status
Orange	Or	Orange	If No Red Status: Pop & Push Orange Status
Green	And	Green	If No Red Status: Pop & Push Green Status

g) Search for the tuples in the DTG to Link (radio links) Mapping Relation that match the DTG_Node_Id and DTG_Id in step 3.d).

h) Search for the tuples in the Item (radio links) Status Relation that match the Node_Id and Item_Id in step 3.g). Next evaluate and assign a new status to each radio link tuple based on TABLE 2.

4. If the component in the status message is a GRC-103 Radio Unit then the following are executed:

a) Search for the tuple in the GRC-103 Radio Unit to Radio Link Mapping Relation that matches the Unit_Id, Node_Id, Equipment_Id, Component attributes in the status message.

b) Search for the tuple in the Item (radio link) Status Relation that matches the Node_Id and Item_Link_Id attributed in step 4.a). Then push a red status with the current Message_Id on the tuple's Status_Stack attribute.

c) Search for the tuples in the DTG to Link (radio links) Mapping Relation that match the Link_Node_Id and Link_Id in step 4.b).

d) Search for the tuples in the Item (DTGs) Status Relation that match the Node_Id and Item_Id in step 4.c) and push a red status with the current Message_Id on the tuples' Status_Stack attribute.

e) Search for the tuples in the Item (radio links) Status Relation that match the Node_Id and Item_Id in step 4.c). Next evaluate and assign a new status to each radio link tuple based on TABLE 2.

f) Search for the tuples in the DTG to Link (cable links) Mapping Relation that match the DTG_Node_Id and DTG_Id in step 4.d).

g) Search for the tuples in the Item (cable links) Status Relation that match the Node_Id and Link_Id in step 4.f). Next evaluate and assign a new status to each cable link tuple based on TABLE 2.

5. If the component in the status message is a GM Slot then the following are executed:

a) Search for the tuple in the GM Slot to Cable Link Mapping Relation that matches the Unit_Id, Node_Id, Equipment_Id, Component attributes in the status message.

b) Search for the tuple in the Item (cable link) Status Relation that matches the Node_Id and Item_Id attributes from step 5.a). Then push a red status with the current Message_Id on the tuple's Status_Stack attribute.

c) Search for the tuples in the DTG to Link (cable links) Mapping Relation that match the Link_Node_Id and Link_Id attributes from step 5.b).

d) Search for the tuples in the Item (DTGs) Status Relation that match the Node_Id and Item_Id attributes from step 5.c) and push a red status with the current Message_Id on the tuples' Status_Stack attribute.

e) Search for the tuples in the Item (cable links) Status Relation that match the Node_Id and Item_Id attributes from step 5.c). Next evaluate and assign a new status to each cable link tuple based on TABLE 2.

f) Search for the tuples in the DTG to Link (radio links) Mapping Relation that match the DTG_Node_Id and DTG_Id attributes from step 5.d).

g) Search for the tuples in the Item (radio links) Status Relation that match the Node_Id and Item_Id attributes from step 5.f). Next evaluate and assign a new status to each radio link tuple based on TABLE 2.

6. Search for the TRC-173 tuple in the Basic Equipment Relation that matches the Unit_Id, Node_Id, and Equipment_Id attributes in the status message. Next evaluate and assign a new status to this tuple based on TABLE 3.

TABLE 3: TRC-173 THAT GENERATED MESSAGE STATUS

If Current Link Status Is	And	All DTGs That Map To This Link are	Then Do The Following To The Status_Stack
Green		Green	No Change
Green		Red	Pop & Push Red Status & Message_Id
Green		Green & Red	Pop & Push Orange Status
Orange		Green	Pop & Push Green Status
Orange		Red	Pop & Red Status & Message_Id
Orange		Green & Red	Pop & Push To Orange Status
Blue		Green	Pop & Push Green Status
Blue		Red	Pop & Push Red & Message_Id
Blue		Green & Red	Pop & Push Orange Status
Red		Green	Search & Remove Red Status That Has the Same Message_Id As The Current Status Message If No Additional Red Status Then Push Green Status
Red		Red	Push Red Status & Message_Id
Red		Green & Red	Search & Remove Red Status That Has the Same Message_Id As The Current Status Message If No Additional Red Status Then Push Green Status

7. Evaluate the status of each TRC-173 that is affected by the propagation of this status message. This is accomplished by searching the Basic Equipment Relation for each TRC-173 (except the one in the status message) and then determining their status by TABLE 4.

8. Evaluate the status of each TTC-39D that is affected by the propagation of this status message. This is accomplished by searching the Basic Equipment Relation for each TTC_39D and then determining their status by TABLE 5.

TABLE 4: TRC-173 THAT DID NOT GENERATE MESSAGE STATUS

Overall Cable Links' Status Is	Then Do The Following To The Status_Stack
Blue	If No Red Status: Pop & Push Blue Status
Orange	If No Red Status: Pop & Push Orange Status
Green	If No Red Status: Pop & Push Green Status

9. Evaluate the status of each RMC that is affected by the propagation of this status message. This is accomplished by searching the Basic Equipment Relation for each RMC and then determining their status by TABLE 5.

B. Component Green and In-system Sub-module Algorithm Steps

1. Check whether all components' (that match the component type in the status message) statuses are red. If true, search for a tuple in the Basic Equipment Relation

TABLE 5: TTC-39D OR RMC STATUS

If Overall Radio Links' Status Is	Oper	Overall Cable Links' Status Is	Then Do The Following To The Status_Stack
Red	And	Red	Push Red Status & Message_Id
Blue	Or	Blue	If No Red Status: Pop & Push Blue Status
Orange	Or	Orange	If No Red Status: Pop & Push Orange Status
Green	And	Green	If No Red Status: Pop & Push Green Status

that matches the Unit_Id, Node_Id, and Equipment_Id attributes in the status message. Then pop the red status with the same Message_Id as the current status message from the tuple's Status_Stack attribute. If the tuple's Status_Stack is free of red status values then push an orange status on the stack.

2. Search for a tuple in the TRC-173 Components Relation that matches the Unit_Id, Node_Id, and Equipment_Id attributes in the status message. When the tuple is found change its component (identified in the status message) to status indicated (in the status message).

3. If the component in the status message is an internal component then the following are executed:

a) Find the GRC-103, in the tuple from step 1, that has the same System_Number as in the status message.

b) Search for a tuple in the GRC-103 Radio Unit to Radio Link Relation that matches the Unit_id, Node_Id, Equipment_Id, and GRC-103 from step 3.a).

c) Search for the tuples in the DTG to Link (radio links) Mapping Relation that match the Link_Node_Id and Link_Id attributes from step 3.b).

d) Search for the tuples in the Item(DTGs) Status Relation that match the Node_Id and Item_Id attributes in step 3.c). Then pop the red status with the same Message_Id as the current status message from the tuple's Status_Stack attribute. If the tuple's Status_Stack is free of red status values then push a green status on the stack.

e) Search for the tuples in the DTG to Link (cable links) Mapping Relation that match the Item_Node_Id and Item_Id attributes from step 3.d).

f) Search for the tuples in the Item (cable links) Status Relation that match the Node_Id and Item_Id attributes from step 3.e). Next evaluate and assign a new status to each cable link tuple based on TABLE 2.

g) Search for the tuples in the DTG to Link (radio links) Mapping Relation that match the DTG_Node_Id and DTG_Id attributes from step 3.d).

h) Search for the tuples in the Item (radio links) Status Relation that match the Node_Id and Item_Id attributes from step 3.g). Next evaluate and assign a new status to each radio link tuple based on TABLE 2.

4. If the component in the status message is a GRC-103 Radio Unit then the following are executed:

a) Search for the tuple in the GRC-103 Radio Unit to Radio Link Mapping Relation that matches the Unit_Id, Node_Id, Equipment_Id, Component_Id attributes in the status message.

b) Search for the tuple in the Item (radio link) Status Relation that matches the Node_Id and Item_Id attributes from step 4.a). Then pop the red status with the same Message_Id as the current status message from the tuple's Status_Stack attribute. If the tuple's Status_Stack is free of red status values then push a green status on the stack.

c) Search for the tuples in the DTG to Link (radio links) Mapping Relation that match the Link_Node_Id and Link_Id attributes from step 4.b).

d) Search for the tuples in the Item (DTGs) Status Relation that match the Node_Id and Item_Id attributes from step 4.c). Then pop the red status with the same Message_Id as the current status message from the tuple's Status_Stack attribute. If the tuple's Status_Stack is free of red status values then push a green status on the stack.

e) Search for the tuples in the Item (radio links) Status Relation that match the Node_Id and Item_Id attributes from step 4.c). Next evaluate and assign a new status to each radio link tuple based on TABLE 2.

f) Search for the tuples in the DTG to Link (cable links) Mapping Relation that match the DTG_Node_Id and DTG_Id attributes from step 4.d).

g) Search for the tuples in the Item (cable links) Status Relation that match the Node_Id and Item_Id attributes from step 4.f). Next evaluate and assign a new status to each cable link tuple based on TABLE 2.

5. If the component in the status message is a GM Slot then the following are executed:

a) Search for the tuple in the GM Slot to Cable Link Mapping Relation that matches the Unit_Id, Node_Id, Equipment_Id, Component attributes in the status message.

b) Search for the tuple in the Item (cable link) Status Relation that matches the Node_Id and Item_Id attributes in step 5.a). Then pop the red status with the same Message_Id as the current status message from the tuple's Status_Stack attribute. If the tuple's Status_Stack is free of red status values then push a green status on the stack.

c) Search for the tuples in the DTG to Link (cable links) Mapping Relation that match the Link_Node_Id and Link_Id attributes from step 5.b).

d) Search for the tuples in the Item (DTGs) Status (Relation that match the Node_Id and Item_Id attributes from step 5.c). Then pop the red status with the same Message_Id as the current status message from the tuples' Status_Stack attribute. If the tuples' Status_Stack is free of red status values then push a green status on the stack.

e) Search for the tuples in the Item (cable links) Status Relation that match the Node_Id and Item_Id attributes from step 5.c). Next evaluate and assign a new status to each cable link tuple based on TABLE 2.

f) Search for the tuples in the DTG to Link (radio links) Mapping Relation that match the DTG_Node_Id and DTG_Id attributes from step 5.d).

g) Search for the tuples in the Item (radio links) Status Relation that match the Node_Id and Item_Id in step 5.f). Next evaluate and assign a new status to each radio link tuple based on TABLE 2.

6. Search for the tuple in the Basic Equipment Relation that matches the Unit_Id, Node_Id, and Equipment_Id attributes in the status message. Next evaluate and assign a new status based on TABLE 3.

7. Evaluate the status of each TRC-173 that is affected by the propagation of this status message. This is accomplished by searching the Basic Equipment Relation for each TRC-173 (except the one in the status message) and then determining their status by TABLE 4.

8. Evaluate the status of each TTC-39D that is affected by the propagation of this status message. This is accomplished by searching the Basic Equipment Relation for each TTC_39D and then determining their status by TABLE 5.

9. Evaluate the status of each RMC that is affected by the propagation of this status message. This is accomplished by searching the Basic Equipment Relation for each RMC and then determining their status by TABLE 5.

C. Component Red and Not In-system Sub-module Algorithm Steps

1. Search for a tuple in the TRC-173 Components Relation that matches the Unit_Id, Node_Id, and Equipment_Id attributes in the status message. When the tuple is found change its component (identified in the status message) to the status indicated (in the status message).

2. Check if the remaining component's (that match the component type in the status message) status are also red. If true, search for a tuple in the Basic Equipment Relation that matches the Unit_Id, Node_Id, and Equipment_Id attributes in the status message. Then push a red status with the current Message_Id on the tuple's Status_Stack attribute.

D. Component Green and Not In-system Sub-module Algorithm Steps

1. Check whether all components' (that match the component type in the status message) statuses are red. If true, search for a tuple in the Basic Equipment Relation that matches the Unit_Id, Node_Id, and Equipment_Id attributes in the status message. Then pop the red status with the same Message_Id as the current status message from the tuple's Status_Stack attribute. If the tuple's Status_Stack is free of red status values then push an orange status on the stack.

2. Search for a tuple in the TRC-173 Components Relation that matches the Unit_Id, Node_Id, and Equipment_Id attributes in the status message. When the tuple is found change its component (identified in the status message) to the status indicated (in the status message).

APPENDIX D: MANAGEMENT SYSTEM FLOW DIAGRAMS

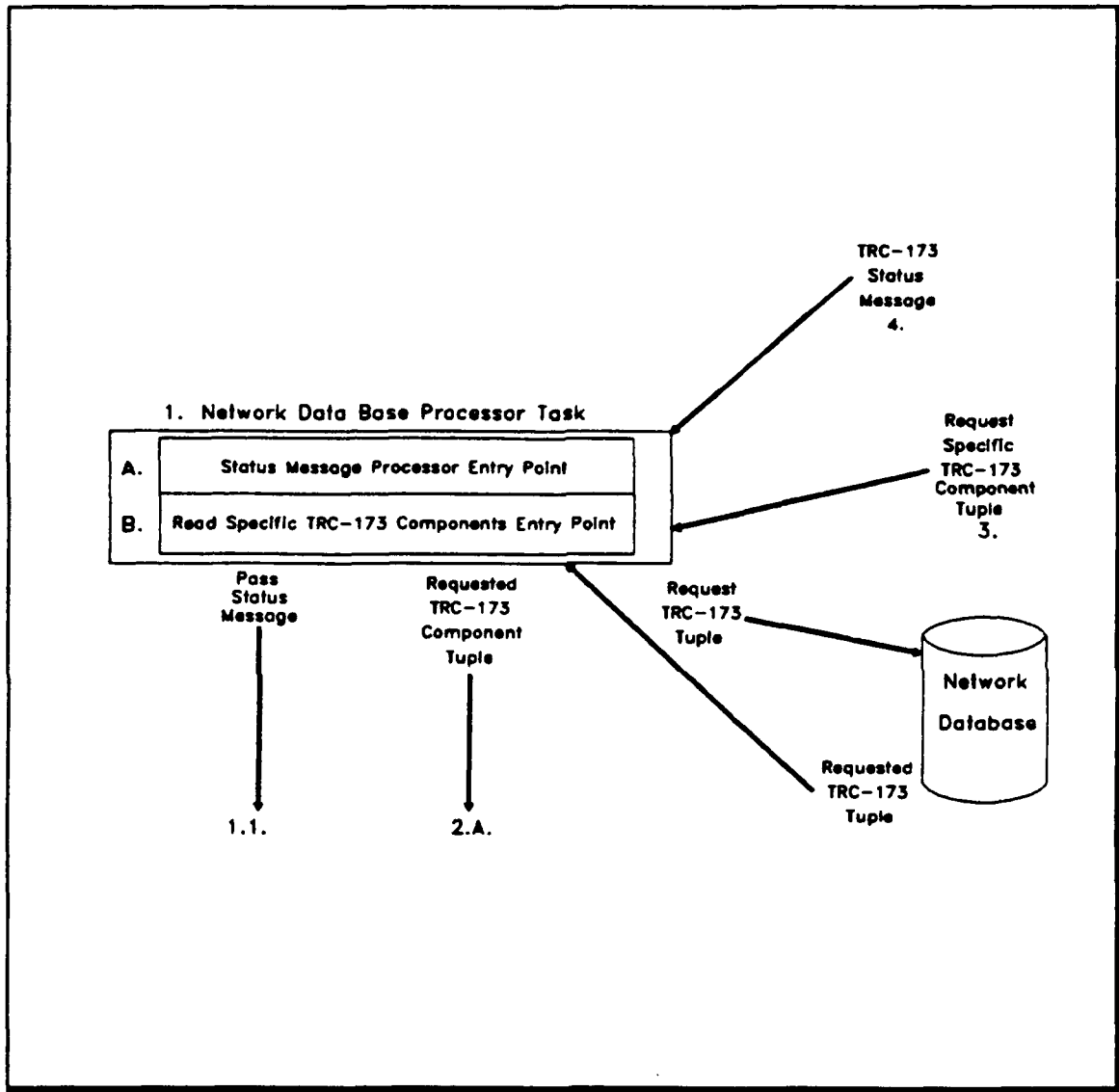

Figure 40: Network Database Processor Task Flow Diagram

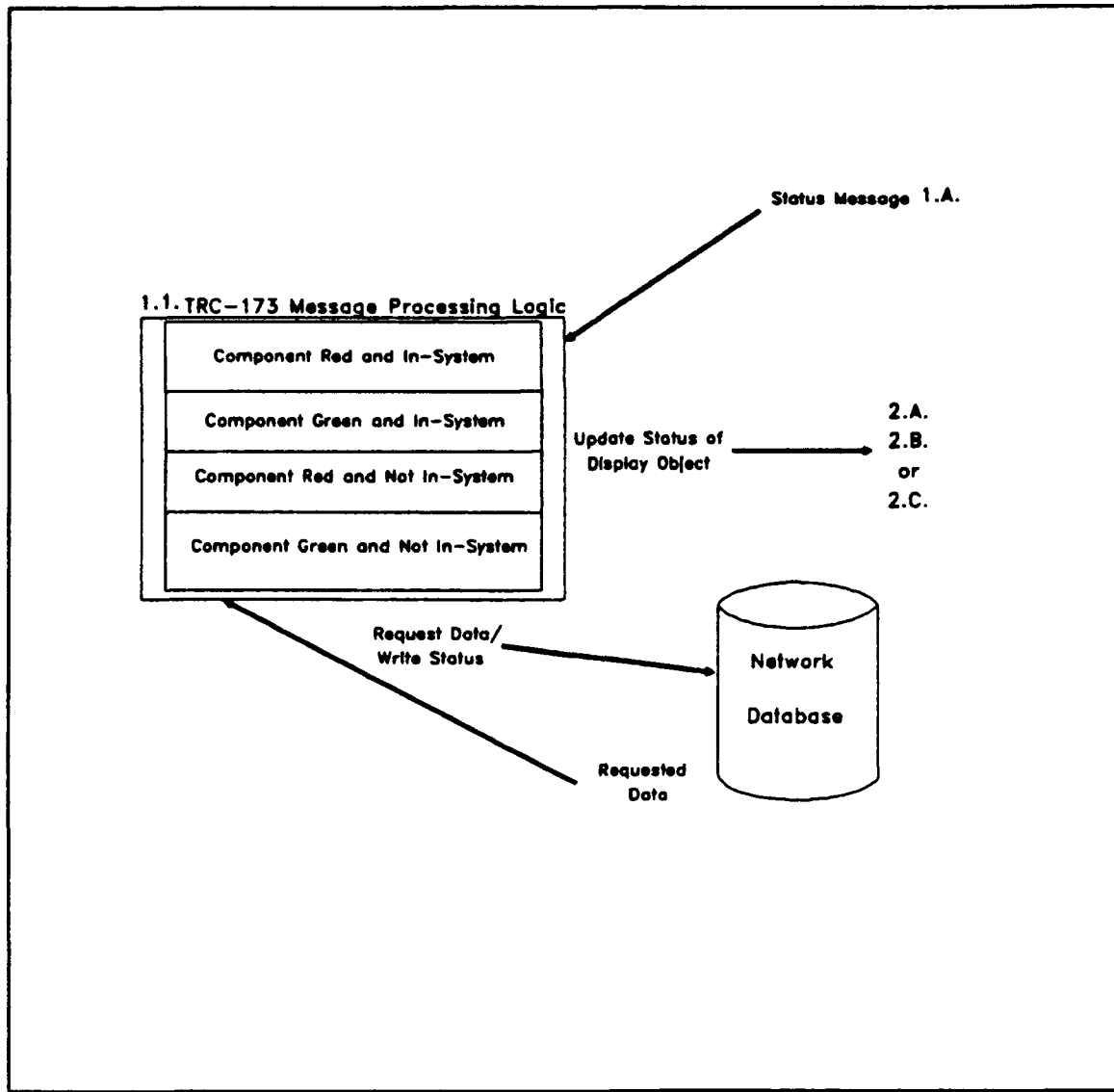

Figure 41: TRC-173 Message Processing Logic Flow Diagram

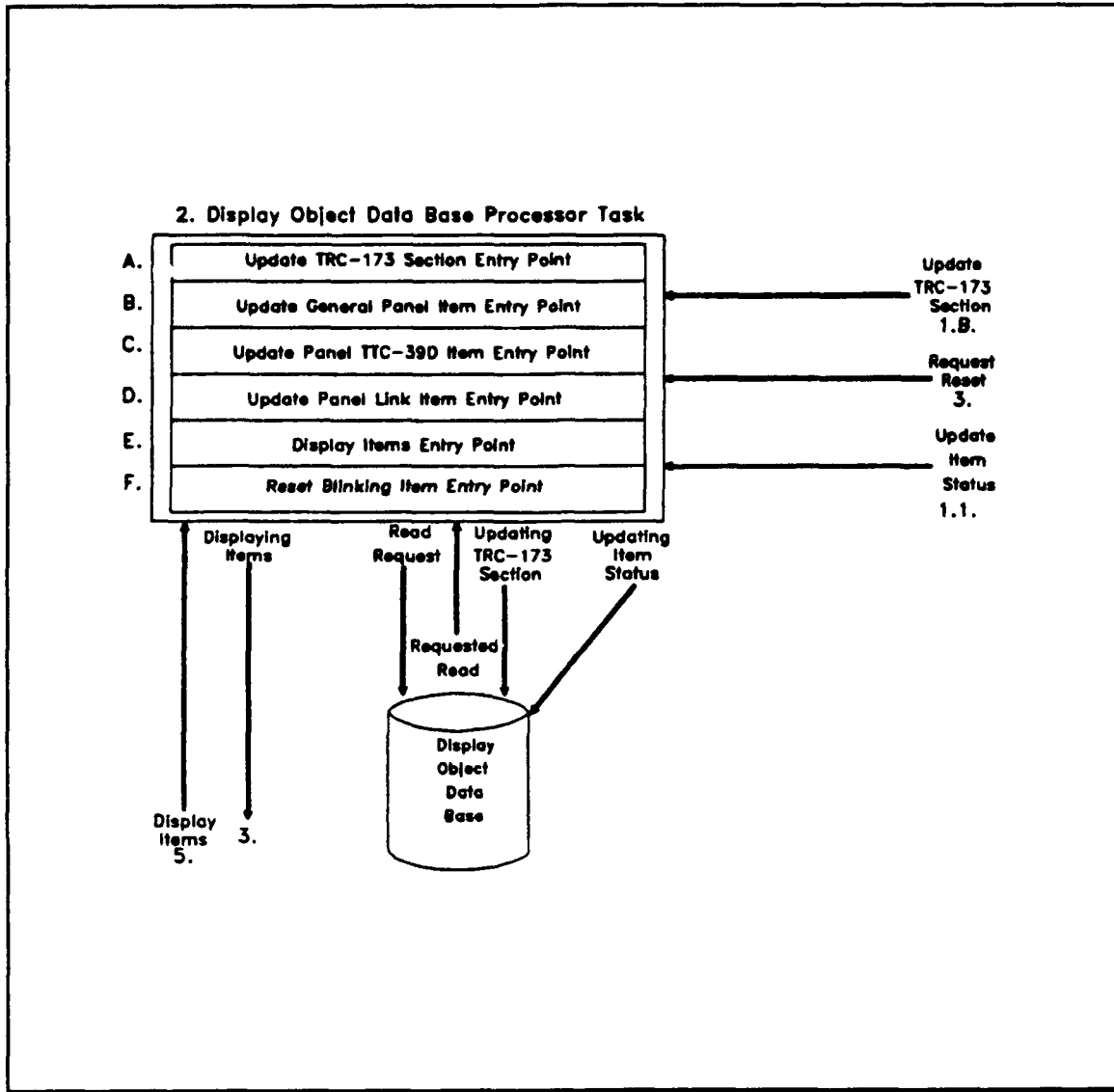

Figure 42: Display Object Database Processor Task Flow Diagram

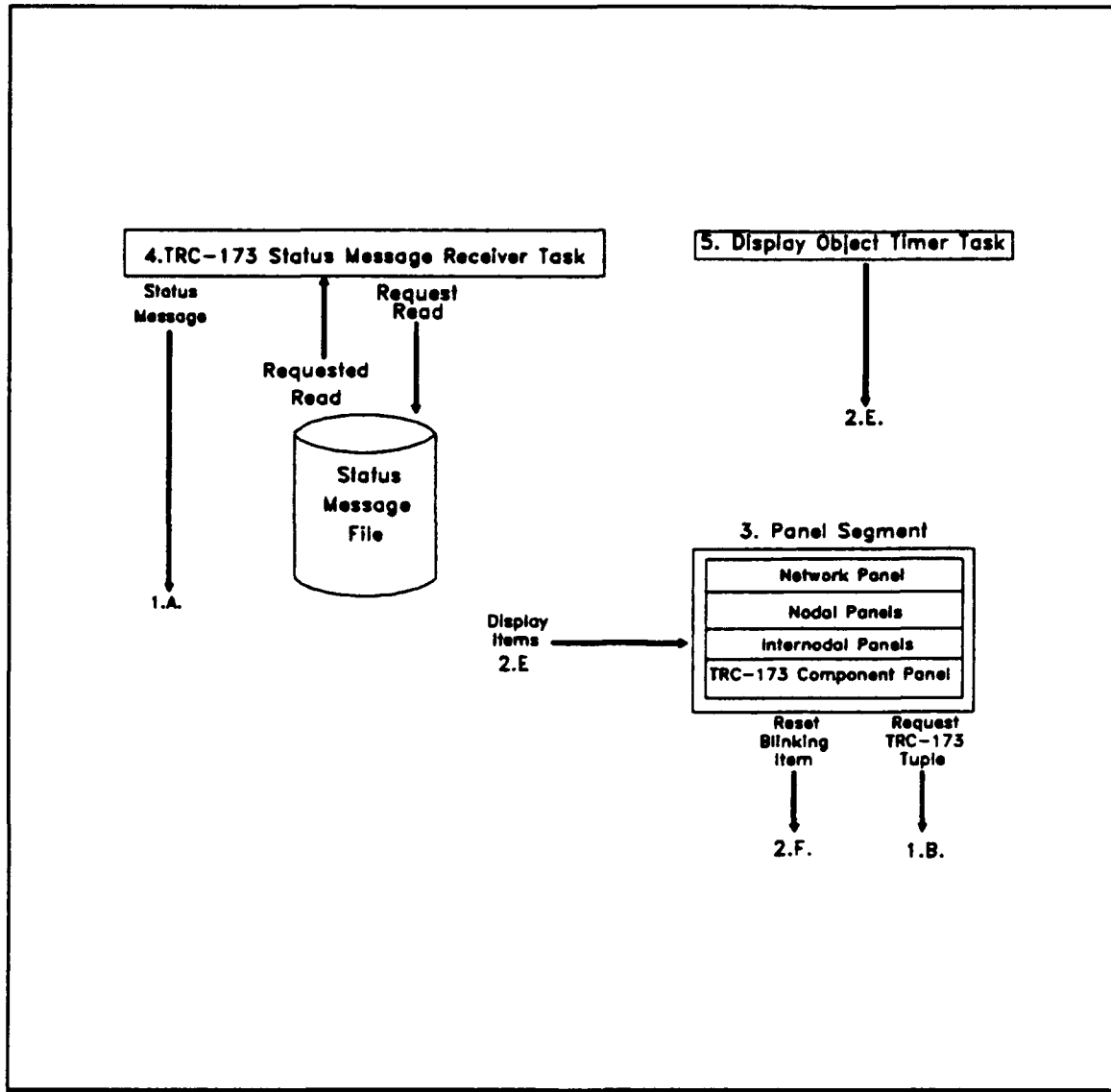

Figure 43: Other Flow Diagrams

REFERENCES

- [Ref. 1] Commander, U.S. Army Signal Center and Fort Gordon, Attention: ATZH-CDM, Fort Gordon, Georgia 30905-5000, SUBJECT: Required Operational Capabilities for the Integrated System Control, UNCLASSIFIED, 5 December 1990.
- [Ref. 2] Department of the Army, Field Manual 11-23, Signal Support Responsibilities: Echelons Above Corps (EAC) (Final Draft), November 1990.
- [Ref. 3] Department of the Army, Special Text 11-30, Corps/Division Signal Unit Operations, 30 June 1989.
- [Ref. 4] Department of Defense, Joint and Multiservice Publication 6-05.4, Joint Transmission Systems, 1 July 1990.
- [Ref. 5] Department of Defense, Joint and Multiservice Publication 6-05.2, Joint Voice Communications Systems (Draft), 19 June 1992.
- [Ref. 6] GTE Mobile Subscriber Equipment Division, 400 John Quincy Adams Road, Taunton, Massachusetts 02780, Mobile Subscriber Equipment: Commander's Brief, 1992.
- [Ref. 7] Commander, U.S. Army Signal Center and Fort Gordon, Directorate of Combat Developments, Fort Gordon Georgia 30905-5000, Briefing: Echelons Above Corps Improvement Program Communications, UNCLASSIFIED, 1989.
- [Ref. 8] Commander, U.S. Army Signal Center and Fort Gordon, Directorate of Combat Developments, Fort Gordon Georgia 30905-5000, Briefing: Battlefield Information Architecture Near, Mid, and Far Term, UNCLASSIFIED, 4 April 1991.
- [Ref. 9] The MITRE Corporation, 145 Wyckoff Road, Eatontown, New Jersey 07702, Initial Investigation Into The Feasibility of Orderwire Telemetry Acquisition For The Communications Systems Control Element (CSCE), November 1990.
- [Ref. 10] GTE Mobile Subscriber Equipment Division, 400 John Quincy Adams Road, Taunton, Massachusetts 02780, Mobile Subscriber Equipment (MSE): System Control Center (SCC) Requirements Document SCC Operational Messages, 10 June 1992.
- [Ref. 11] Terplan, K., Communication Networks Management, Prentice-Hill, Inc., 1987.

- [Ref. 12] National Aeronautics and Space Administration, Goddard Space Flight Center, Transportable Applications Environment Plus User Interface Developer's Guide, v.5.1, April 1991.
- [Ref. 13] Pressman, R. S., Software Engineering: A Practitioner's Approach, McGraw-Hill, Inc., 1982.

INITIAL DISTRIBUTION LIST

1. Defense Technical Information Center 2
Cameron Station
Alexandria, VA 22304-6145
2. Dudley Knox Library 2
Code 52
Naval Postgraduate School
Monterey, CA 93943-5002
3. Dr. Ted Lewis, Chairman 1
Computer Science Department
Naval Postgraduate School
Monterey, CA 93943-5000
4. Dr. G. M. Lundy 1
Code CS/Ln
Assistant Professor, Computer Science Department
Naval Postgraduate School
Monterey, CA 93943-5000
5. Commander, USASC&FG 1
Attn: ATZH-CDM (Don Jones)
Ft. Gordon, GA 30905-5075
6. Project Manager 1
Multi-Service Communications System
Attn: SFAE-CM-MS-CMS
Ft. Monmouth, NJ 07703-5000
7. CPT Gregory M. Johnson 3
13122 Pavilion Lane
Fairfax, VA 22033
8. LCDR John A. Daley 1
Code CS/Da
Computer Science Department
Naval Postgraduate School
Monterey, CA 93943-5000