

AD-A275 106



WL-TR-93-2025

**PERFORMANCE EVALUATION OF A
22.5/30 KW 270 VOLTS DIRECT CURRENT
GENERATOR SYSTEM**

John G. Nairus, David A. Criminski
Power Components Branch
Aerospace Power Division

February 1993

Final Report for Period January 1992 - January 1993

Approved for public release, distribution is unlimited.

AERO PROPULSION AND POWER DIRECTORATE
WRIGHT LABORATORY
AIR FORCE MATERIEL COMMAND
WRIGHT-PATTERSON AIR FORCE BASE, OHIO 45433-7251

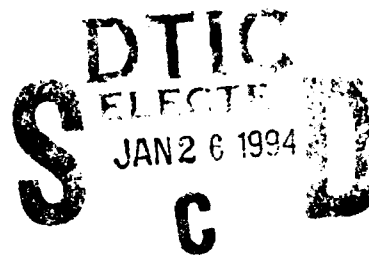

94 1 25 057

153

94-02159

NOTICE

When Government drawings, specifications, or other data are used for any purpose other than in connection with a definitely Government-related procurement, the United States Government incurs no responsibility or any obligation whatsoever. The fact that the government may have formulated or in any way supplied the said drawings, specifications, or other data, is not to be regarded by implication, or otherwise in any manner construed, as licensing the holder, or any other person or corporation; or as conveying any rights or permission to manufacture, use, or sell any patented invention that may in any way be related thereto.

This report is releasable to the National Technical Information Service (NTIS). At NTIS, it will be available to the general public, including foreign nations.

This technical report has been reviewed and is approved for publication.



John G. Nairus
Electrical Engineer
Power Components Branch
Aerospace Power Division
Aero Propulsion and Power Directorate



Charles W. Anderson
Chief, Power Components Branch
Aerospace Power Division
Aero Propulsion and Power Directorate



Michael D. Braydich, Lt Col, USAF
Deputy Chief, Aerospace Power Division
Aero Propulsion and Power Directorate

If your address has changed, if you wish to be removed from our mailing list, or if the addressee is no longer employed by your organization please notify WL/POOC, WPAFB, OH 45433-7251 to help us maintain a current mailing list.

Copies of this report should not be returned unless return is required by security considerations, contractual obligations, or notice on a specific document.

REPORT DOCUMENTATION PAGE

Form Approved
OMB No. 0704-0188

Public reporting burden for this collection of information is estimated to average 1 hour per response, including the time for reviewing instructions, searching existing data sources, gathering and maintaining the data needed, and completing and reviewing the collection of information. Send comments regarding this burden estimate or any other aspect of this collection of information, including suggestions for reducing this burden, to Washington Headquarters Services, Directorate for Information Operations and Reports, 1215 Jefferson Davis Highway, Suite 1204, Arlington, VA 22202-4302, and to the Office of Management and Budget, Paperwork Reduction Project (0704-0188), Washington, DC 20503.

1. AGENCY USE ONLY (Leave blank)		2. REPORT DATE December 1993	3. REPORT TYPE AND DATES COVERED Final 1/92 - 1/93	
4. TITLE AND SUBTITLE Performance Evaluation of a 22.5/30 kW 270 Volts Direct Current Generator System			5. FUNDING NUMBERS Program Element No. 62203F Work Unit No. 31452939	
6. AUTHOR(S) John G. Nairus, David A. Criminski			8. PERFORMING ORGANIZATION REPORT NUMBER WL-TR-93-2025	
7. PERFORMING ORGANIZATION NAME(S) AND ADDRESS(ES) WL/POOC-1 Bldg 18 1950 Fifth St. Wright Patterson AFB OH 45433-7251			9. SPONSORING/MONITORING AGENCY NAME(S) AND ADDRESS(ES)	
9. SPONSORING/MONITORING AGENCY NAME(S) AND ADDRESS(ES)			10. SPONSORING/MONITORING AGENCY REPORT NUMBER	
11. SUPPLEMENTARY NOTES				
12a. DISTRIBUTION/AVAILABILITY STATEMENT Approved for public release; distribution is unlimited.			12b. DISTRIBUTION CODE	
13. ABSTRACT (Maximum 200 words) This report documents the electrical system performance testing of a 12-pole, wound rotor machine with integral 3:1 speed increaser and rectifier, 22.5/30 kW 270 Vdc generator system. The performance testing was accomplished in the generator test facility of the Aerospace Power Division (WL/POOC-1). This report also documents WL/POOC-1's Data Acquisition System modified for 270 Vdc test and analysis. Generator system parameters measured include transient responses to load applications and removals, ripple voltages, distortion spectrums, and fault currents. Results were compared to electrical system characteristics specified in MIL-STD-704E.				
14. SUBJECT TERMS			15. NUMBER OF PAGES 154	
			16. PRICE CODE	
17. SECURITY CLASSIFICATION OF REPORT Unclassified	18. SECURITY CLASSIFICATION OF THIS PAGE Unclassified	19. SECURITY CLASSIFICATION OF ABSTRACT Unclassified	20. LIMITATION OF ABSTRACT	

FOREWORD

This report documents the electrical performance testing of an AV-8B generator modified to be a 22.5/30 kW 270 Vdc primary power generation system. The performance testing was accomplished using the generator test facility of the Aerospace Power Division. An advanced high-speed digital data acquisition system was used extensively in that it ran the test sequences, collected the data, and ran the analysis routines on the data.

This effort was accomplished by the Power Components Branch (POOC), Aerospace Power Division (POO), Aero Propulsion and Power Directorate, Wright Laboratory, Wright-Patterson Air Force Base, Ohio, under work unit 31452939, "Advanced Aircraft Electrical Power Generation and Distribution" with John G. Nairus leading the technical effort, supported by David A. Criminski of the University of Dayton Research Institute who was responsible for the data acquisition system software development and implementation. Samuel W. Sexton was the technician for both generator setup and test.

DTIC QUALITY INSPECTED 5

Accession For	
NTIS CRA&I	<input checked="" type="checkbox"/>
DTIC TAB	<input type="checkbox"/>
Unannounced	<input type="checkbox"/>
Justification:	
By _____	
Distribution/	
Availability Codes	
Dist	Avail and/or Special
A-1	

CONTENTS

SECTION		PAGE
	FOREWORD	iii
	TABLE OF CONTENTS	v
	FIGURES	vi
	TABLES	ix
1	INTRODUCTION	1
2	DISCUSSION	4
	Objective	4
	Data Acquisition and Hardware	4
	Test Hardware	11
	Test Setup	11
3	TEST RESULTS	18
	Transient Characteristics	18
	Ripple Characteristics	62
	Generator Acceleration/Deceleration	75
	Distortion Characteristics	75
	Fault Current	92
4	CONCLUSIONS	99
	REFERENCES	100
	APPENDIX A TEST SEQUENCE DESCRIPTIONS	101
	APPENDIX B TEST EXECUTION LOG	103

FIGURES

NUMBER	TITLE	PAGE
1	Overview of VAXstation III/GPX and Generator Test Facility	2
2	Drive Stand Controls	5
3	CAMAC Crate #1	6
4	CAMAC Crate #2	7
5	Generator Test Facility Generator Instrumentation Interface	8
6	Drive Stand #3 Instrumentation Interface	9
7	Load Bank Controller	10
8	Manual Control Panel for 270 VDC Load Bank	12
9	Drive Stand #3 Control Panel	13
10	Generator System Under Test	14
11	Reverse Angle Generator Close-up	15
12	Test Setup Schematic	16
13	Load Application and Removal, 20 Amps, 4000 rpm	20
14	Load Application and Removal, 20 Amps, 8200 rpm	21
15	Load Application and Removal, 50 Amps, 4000 rpm	22
16	Load Application and Removal, 50 Amps, 8200 rpm	23
17	Load Application and Removal, 80 Amps, 4000 rpm	24
18	Load Application and Removal, 80 Amps, 8200 rpm	25
19	Load Application and Removal, 100 Amps, 4000 rpm	26
20	Load Application and Removal, 100 Amps, 8200 rpm	27
21	Load Application and Removal, 110 Amps, 4000 rpm	28
22	Load Application and Removal, 110 Amps, 8200 rpm	29
23	Overload (1.5 pu) Application and Removal, 120 Amps, 4000 rpm	30
24	Overload (1.5 pu) Application and Removal, 120 Amps, 8200 rpm	31
25	Overload (2.0 pu) Application and Removal, 160 Amps, 4000 rpm	32
26	Overload (2.0 pu) Application and Removal, 160 Amps, 8200 rpm	33
27	Load Application Transient, 20 Amps, (4000 rpm)	34
28	Load Removal Transient, 20 Amps, (4000 rpm)	35
29	Load Application Transient, 50 Amps, (4000 rpm)	36
30	Load Removal Transient, 50 Amps, (4000 rpm)	37
31	Load Application Transient, 80 Amps, (4000 rpm)	38
32	Load Removal Transient, 80 Amps, (4000 rpm)	39
33	Load Application Transient, 100 Amps, (4000 rpm)	40
34	Load Removal Transient, 100 Amps, (4000 rpm)	41
35	Load Application Transient, 110 Amps, (4000 rpm)	42
36	Load Removal Transient, 110 Amps, (4000 rpm)	43

37	Overload (1.5 pu overload) Application Transient, 120 Amps, (4000 rpm)	44
38	Overload (1.5 pu overload) Removal Transient, 120 Amps, (4000 rpm)	45
39	Overload (2.0 pu overload) Application Transient, 160 Amps, (4000 rpm)	46
40	Overload (2.0 pu overload) Removal Transient, 160 Amps, (4000 rpm)	47
41	Load Application Transient, 20 Amps, (8200 rpm)	48
42	Load Removal Transient, 20 Amps, (8200 rpm)	49
43	Load Application Transient, 50 Amps, (8200 rpm)	50
44	Load Removal Transient, 50 Amps, (8200 rpm)	51
45	Load Application Transient, 80 Amps, (8200 rpm)	52
46	Load Removal Transient, 80 Amps, (8200 rpm)	53
47	Load Application Transient, 100 Amps, (8200 rpm)	54
48	Load Removal Transient, 100 Amps, (8200 rpm)	55
49	Load Application Transient, 110 Amps, (8200 rpm)	56
50	Load Removal Transient, 110 Amps, (8200 rpm)	57
51	Overload (1.5 pu overload) Application Transient, 120 Amps, (8200 rpm)	58
52	Overload (1.5 pu overload) Removal Transient, 120 Amps, (8200 rpm)	59
53	Overload (2.0 pu overload) Application Transient, 160 Amps, (8200 rpm)	60
54	Overload (2.0 pu overload) Removal Transient, 160 Amps, (8200 rpm)	61
55	Peak-to-Peak Ripple	62
56	No Load Ripple Voltage, 4000 rpm	63
57	No Load Ripple Voltage, 8200 rpm	64
58	Ripple Voltage, 20 Amp Load, 4000 rpm	65
59	Ripple Voltage, 20 Amp Load, 8200 rpm	66
60	Ripple Voltage, 50 Amp Load, 4000 rpm	67
61	Ripple Voltage, 50 Amp Load, 8200 rpm	68
62	Ripple Voltage, 80 Amp Load, 4000 rpm	69
63	Ripple Voltage, 80 Amp Load, 8200 rpm	70
64	Ripple Voltage, 100 Amp Load, 4000 rpm	71
65	Ripple Voltage, 100 Amp Load, 8200 rpm	72
66	Ripple Voltage, 110 Amp Load, 4000 rpm	73
67	Ripple Voltage, 110 Amp Load, 8200 rpm	74
68	Generator Acceleration Under Full Load (Acceleration Rate = 500 rpm/s)	76
69	Generator Acceleration Under Full Load (Acceleration Rate = 1000 rpm/s)	77
70	Generator Deceleration Under Full Load (Deceleration Rate = 500 rpm/s)	78

71	Generator Deceleration Under Full Load (Deceleration Rate = 1000 rpm/s)	79
72	No Load 4000 rpm Distortion Spectrum	80
73	No Load 8200 rpm Distortion Spectrum	81
74	Distortion Spectrum, 20 Amp Load, 4000 rpm	82
75	Distortion Spectrum, 20 Amp Load, 8200 rpm	83
76	Distortion Spectrum, 50 Amp Load, 4000 rpm	84
77	Distortion Spectrum, 50 Amp Load, 8200 rpm	85
78	Distortion Spectrum, 80 Amp Load, 4000 rpm	86
79	Distortion Spectrum, 80 Amp Load, 8200 rpm	87
80	Distortion Spectrum, 100 Amp Load, 4000 rpm	88
81	Distortion Spectrum, 100 Amp Load, 8200 rpm	89
82	Distortion Spectrum, 110 Amp Load, 4000 rpm	90
83	Distortion Spectrum, 110 Amp Load, 8200 rpm	91
84	Generator Short Circuit Fault Sequence, 4000 rpm	93
85	Short Circuit Fault Application, 4000 rpm	94
86	Generator Trip / Fault Clear, 4000 rpm	95
87	Generator Short Circuit Fault Sequence, 8200 rpm	96
88	Short Circuit Fault Application, 8200 rpm	97
89	Generator Trip / Fault Clear, 8200 rpm	98

TABLES

NUMBER	TITLE	PAGE
1	Load Application Transients	19
2	Load Removal Transients	19
3	Peak-to-Peak Ripple Voltage	62
4	Distortion Factors	75

SYMBOLS AND ABBREVIATIONS

A	Ampere
ac	Alternating Current
APPD	Aero Propulsion and Power Directorate
D/A	Digital-to-Analog
DAS	Data Acquisition System
dc	Direct Current
DEC	Digital Equipment Corporation
GCU	Generator Control Unit
hp	Horsepower
Hz	Hertz
kHz	Kilohertz
kW	Kilowatt
ms	milliseconds
P/N	Part Number
POOC-1	Aircraft Electrical Technology Group
pu	per unit
rpm	revolutions per minute
s	seconds
TTL	Transistor Transistor Logic
UDRI	University of Dayton Research Institute
V	Volts
Vdc	Volts Direct Current
V_{pp}	Volts Peak-to-Peak

SECTION I

INTRODUCTION

This report will describe electrical performance testing of a 22.5/30 kW, 270 Vdc power generation system designed specifically for laboratory environments. The generator and generator control unit (GCU) are modified AV-8B hardware. The generator is a 12 pole, wound rotor machine with integral 3:1 speed increaser and rectifier to develop 270 Vdc. The GCU provides control and protection for the 270 Vdc generator. The generator and GCU were procured from Westinghouse Electric Corporation in Lima, OH. Air Force testing of the above generator system served a threefold purpose:

1. Demonstrate the capability of the Aero Propulsion and Power Directorate's (APPD) Aircraft Electrical Laboratory (POOC-1) to test 270 Vdc generator systems.
2. Provide an independent evaluation of the modified AV-8B generator system electrical performance.
3. Demonstrate feasibility of using this power generation system as the primary source of power for the POOC-1 270 Vdc Testbed.

One of the APPD Aircraft Electrical Laboratory's capabilities is to conduct tests of aircraft electrical generating systems. The heart of this capability is the high speed data acquisition system which performs the following functions: control of test execution, control of high-speed data acquisition, data analysis, and data display. These features provide the test engineer the means to conduct generator testing under a wide range of test conditions, to analyze performance of the subject generator in response to test conditions, and to examine the analysis results. Tests are performed with various electrical load levels presented to the generator, including overload and fault conditions. All tests require that the generator be operated at known speeds within its operating range. Some tests require the speed of the generator be changed at specific rates of acceleration or deceleration. Other test conditions may be varied for particular generator system operating conditions.

Real-time monitoring of the generator system parameters is conducted during the test to determine its performance in response to the conditions of the test. Measurements of the raw output data are then processed by various analysis techniques in order to portray a clear measure of the performance of the generator. The combination of these features eliminates many difficulties associated with generator testing. Computer control of test sequence execution insures proper synchronization of test actions, provides a flexible means for specifying all types of test conditions, and requires a minimum of personnel to perform a generator test.

The Digital Equipment Corporation (DEC) VAXstation III/GPX was used as the main system control and display unit. Figure 1 shows the DEC VAXstation III/GPX block

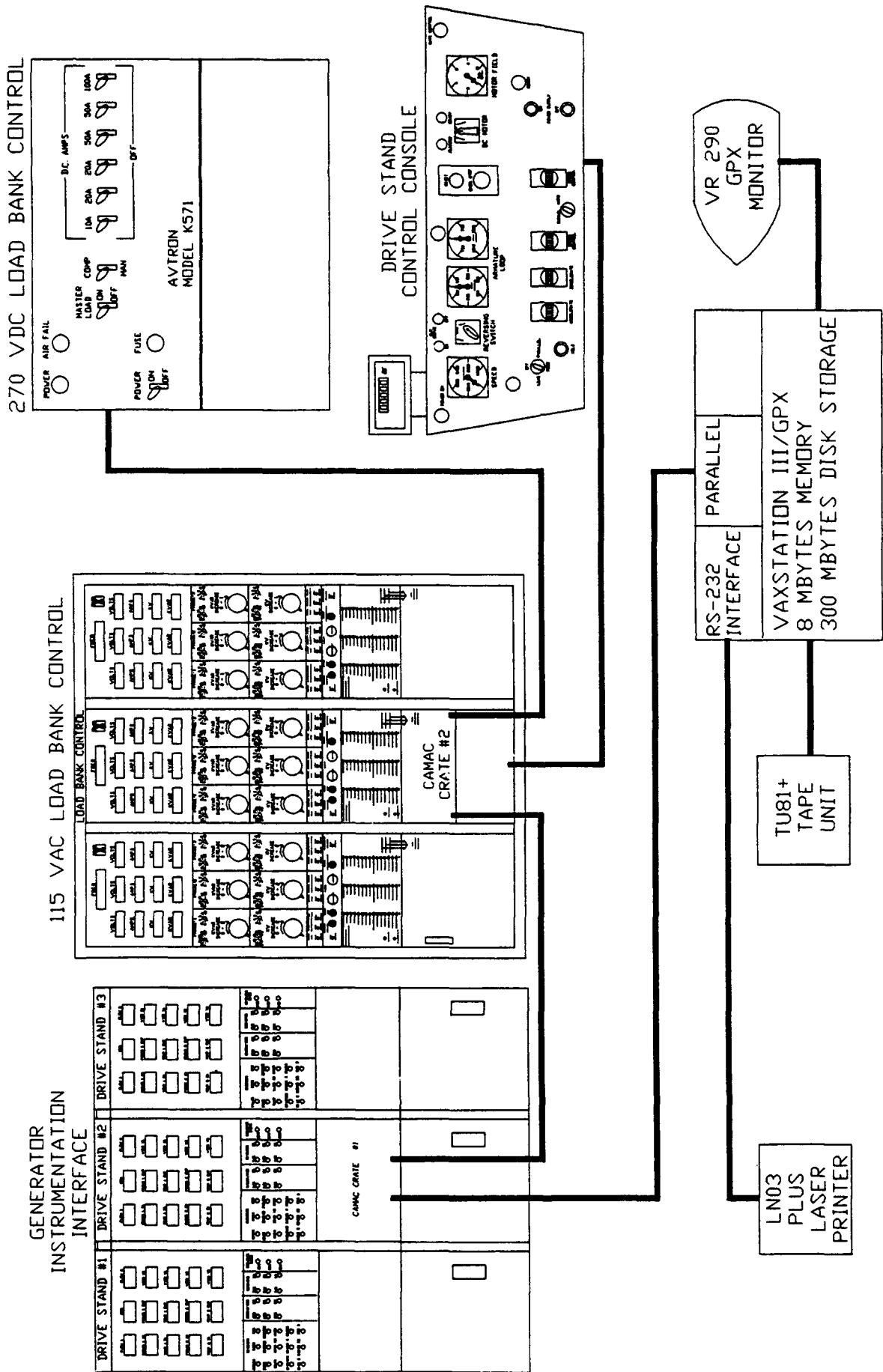

Figure 1
 Overview of VAXstation III/GPX
 and Generator Test Facility

diagram along with the two KineticSystems 25-slot data acquisition and control crates located in the generator instrumentation and ac-load bank interface cabinets. Also shown in this figure are the drive stand controls and the 270 Vdc load bank. The VAXstation III is a 32-bit VAX computer system configured using the extended Q-bus. This computer system is engineered to perform real-time applications and general-purpose programming. The VAXstation III minicomputer is compatible with the larger VAX family of computer systems. The system consists of a VAXstation III/GPX with the following hardware and software:

-- **Hardware:**

- High-performance Color Graphics
1024 x 864 pixel display
- 8 Mbytes of memory
- 301 Mbytes of disc storage
One RD54 a 159 Mbyte drive
Two RD53s each 71 Mbyte drive
- 95 Mbyte magnetic tape unit
- 1600/6250 BPI magnetic tape drive
- 12 EIA RS-232 serial ports
- LN03 Laser Printer

-- **Software:**

- VMS V4.7a - two user license
- DECnet
- FORTRAN-77
- Ada
- C
- CMS
- MMS
- VAXlab
- GKS
- CA-DISSPLA

The remainder of this report describes the test sequences performed on the 22.5/30 kW, 270 Vdc system and the results of these tests.

SECTION 2

DISCUSSION

OBJECTIVE

The objective of this test program was to ascertain electrical performance of the modified AV-8B 22.5/30 kW 270 Vdc system. These performance measurements are derived from analyses performed on test data obtained using the Generator Test Facility of the Aero Propulsion and Power Directorate.

DATA ACQUISITION HARDWARE

This section is a description of the system hardware configuration for the 270 Vdc generator test facility. It illustrates the data control, acquisition, and display system interfaces to the drive stands, generators, generator control system, and to the load banks to acquire data for real-time analysis and displaying of results. The system is capable of executing pre-programmed test sequences written in datafiles with timing control, as well as acquiring data from the generators and load banks.

The generator data acquisition and control system uses Kinetic Systems Corporation transient recorders, memory modules, and discrete I/O modules housed in CAMAC crates. Two crates were used, one for data acquisition and the other for controlling the drive stands, load banks, and relay contacts. Figure 2 shows a diagram of the electrical controls for the 350 hp drive motors. The first 25-slot crate (Figure 3) houses two 8-channel transient recorders, four 1-megaword memory modules, one timing generator module, and one parallel crate controller. The other 25-slot crate (Figure 4) houses 10 16-bit relay output modules, one 48-bit TTL discrete input module, two 8-channel 12 bit D/A converters, and a parallel crate controller module.

The first crate handles all of the data acquisition for tests involving 270 Vdc generators. For the 270 Vdc generator tests, two modules, each with 8-channel 12-bit transient recorders are used. They can be programmed to run at sample frequencies from 5 Hz to a maximum of 31.25 kHz, with all eight channels running simultaneously. One of these transient recorder modules will use two channels to record the voltage and current from the generator. The other module will use a single channel to monitor and record the drive stand speed. Both modules will have two of the 1-megaword memory modules as dedicated memory. There will be 13 channels left as spares. Figure 5 shows the generator instrumentation cabinets where crate 1 is housed. Figure 6 shows a closeup of the generator instrumentation interface for Drive Stand #3. This instrumentation panel is used to monitor pressures, temperatures, and drive stand speed. It also provides the outputs necessary for reading the voltage and current data.

Figure 7 shows the AC load bank cabinet where crate 2 is housed. This crate is used to control the ac and 270 Vdc load banks, the drive stands, and the relay controls. The two 8-channel 12-bit digital-to-analog converters allows for nine analog outputs to

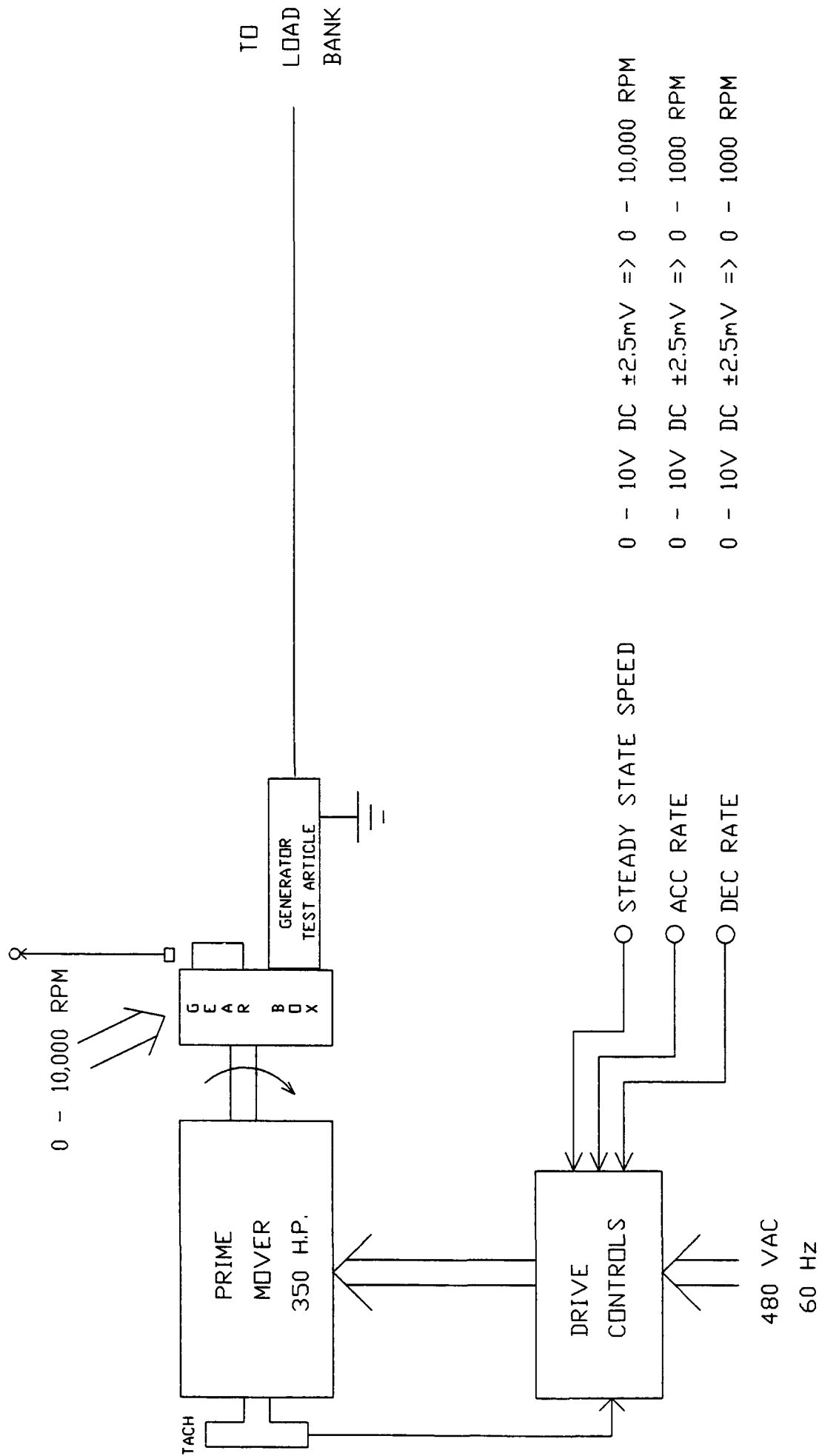

Figure 2
DRIVE STAND CONTROLS

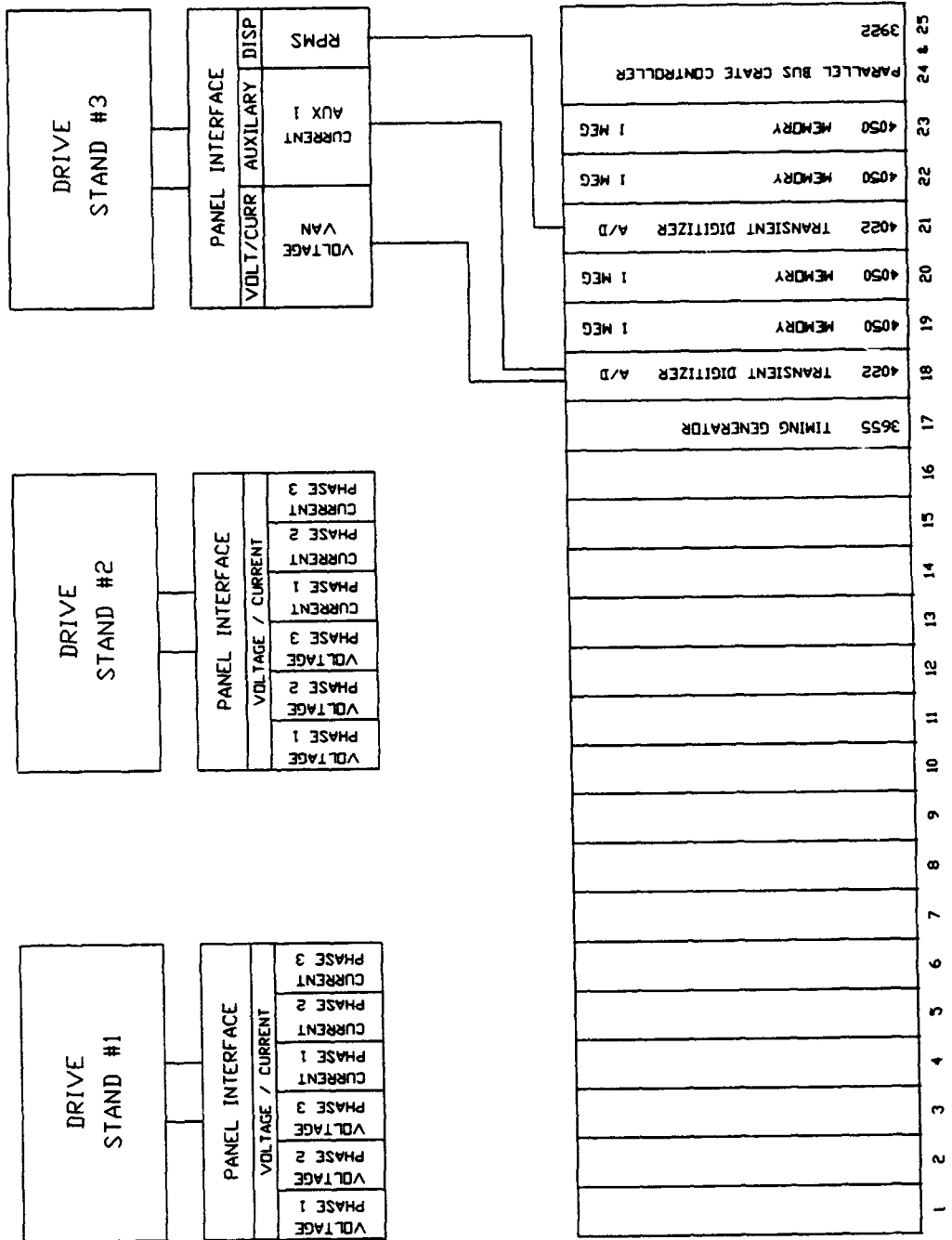

Figure 3
CAMAC CRATE #1

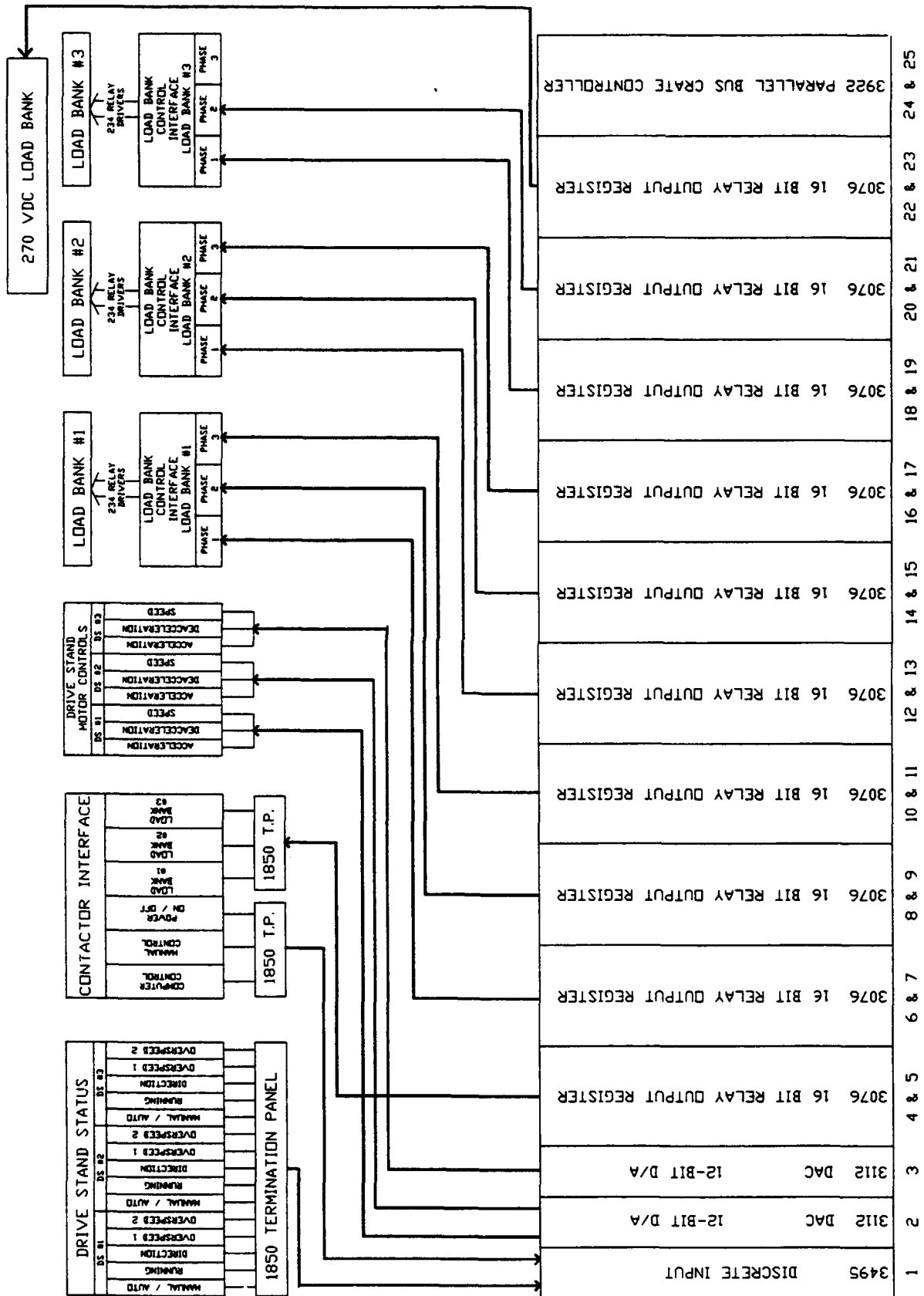

Figure 4

CAMAC CRATE #2

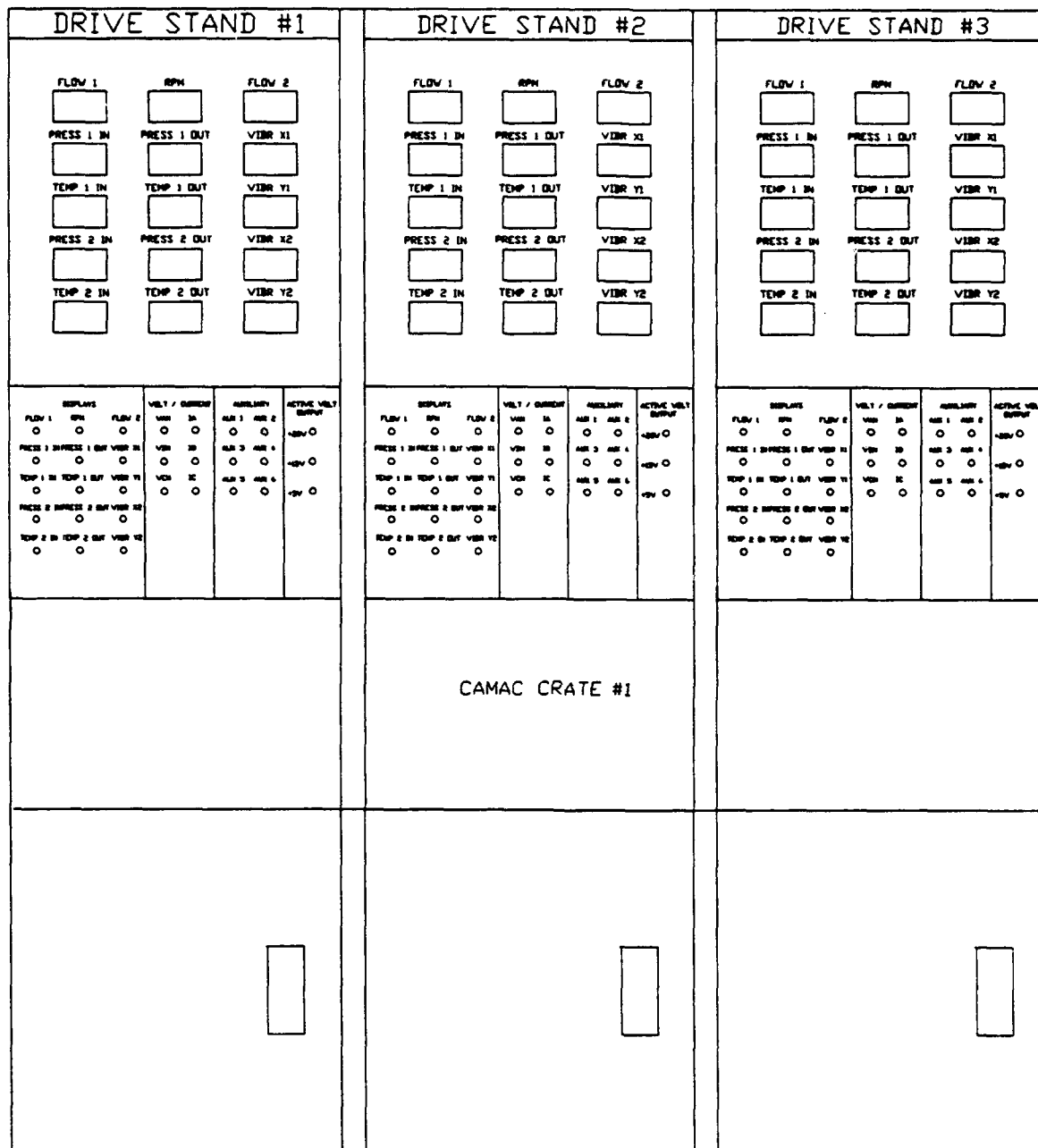

Figure 5
GENERATOR TEST FACILITY
GENERATOR INSTRUMENTATION INTERFACE

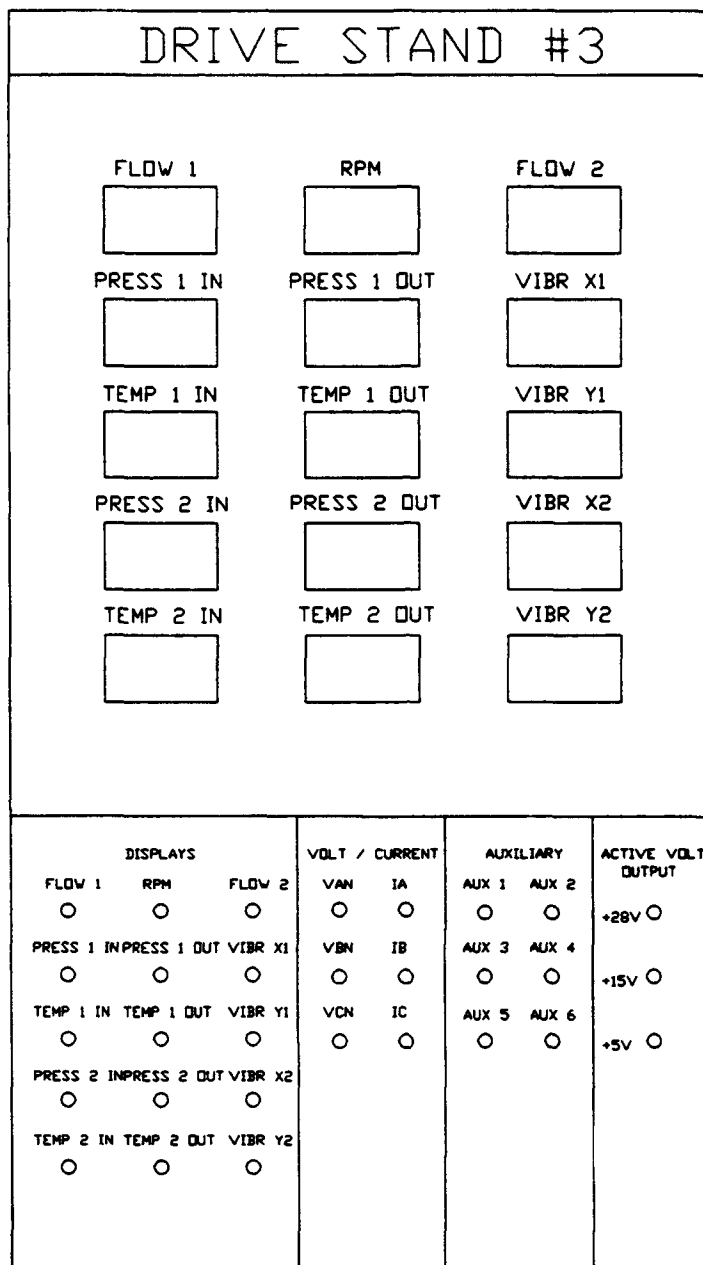

Figure 6
CLOSEUP OF GENERATOR
INSTRUMENTATION INTERFACE
FOR DRIVE STAND #3

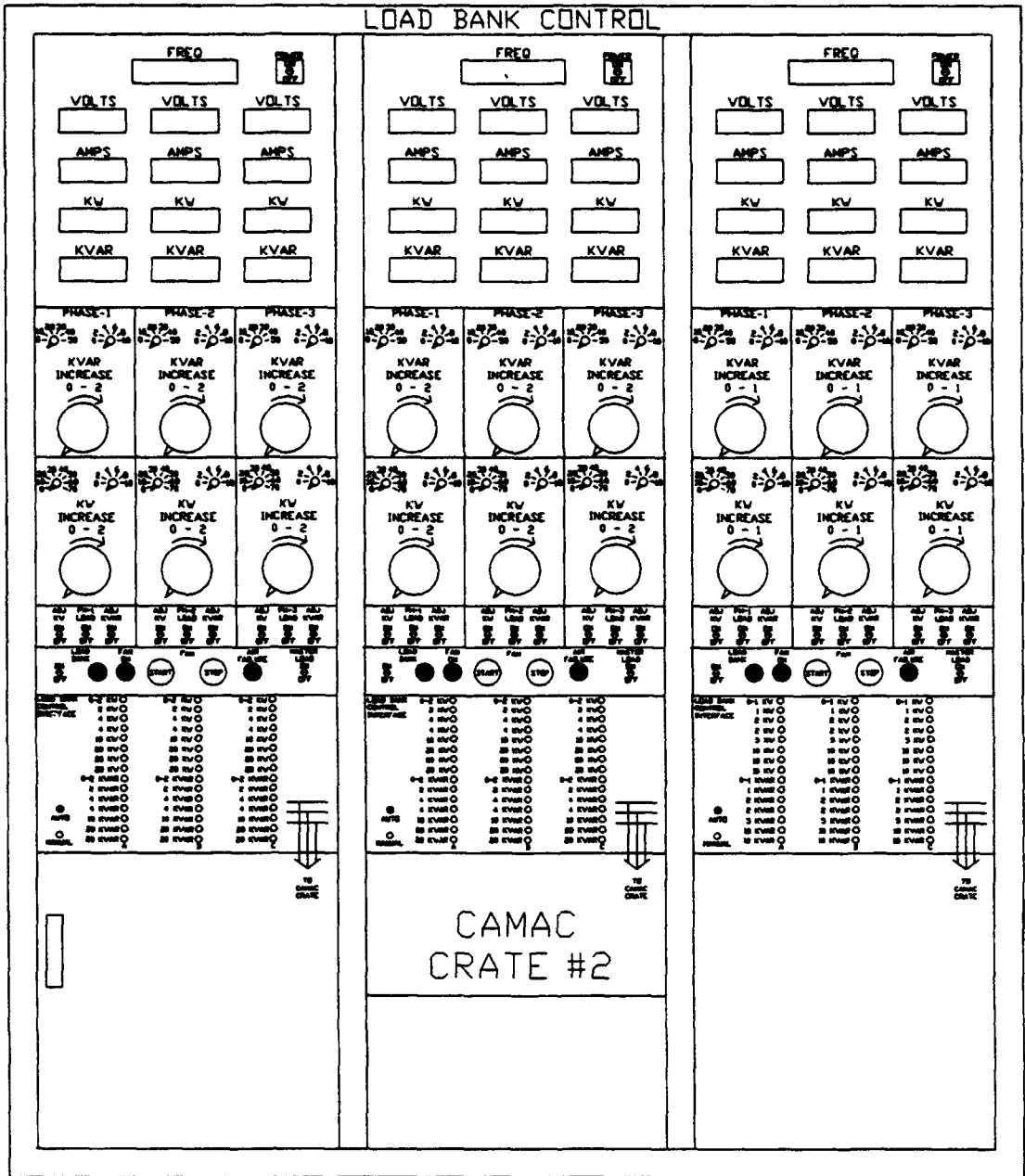

Figure 7
GENERATOR TEST FACILITY
AC LOAD BANK CONTROLLER

control the drive stand motor controls for three generators, leaving three spare outputs. The ten 16-bit relay output modules allows control for 78 load bank relay drivers per ac load bank. A single 16-bit relay output module is used to control the dc load bank. Figure 8 shows the 270 Vdc load bank control panel used for manual operation of the load bank. When the load bank is in computer mode, the load switches on the load bank control panel do not function.

A 48-bit discrete TTL input allows for sensing discrete inputs from the generators, drive stands, or system control components. Figure 9 shows drive stand #3 control panel. Both crates are controlled by crate controllers that interface to the Vaxstation III using a Q-bus parallel adapter with direct memory access.

For a complete description of the subsystem breakdown by individual components see UDRI report "Analysis Procedures Utilizing MIL-STD-704D," Fox, J.A. and Criminski, D.A., UDR-TR-89-57, July 1989, Appendix D. This appendix describes the generator test facility subsystem hardware and includes schematics, descriptions, and wiring diagrams.

TEST HARDWARE

The modified AV-8B system consisted of the following equipment:

Generator DC, Aircraft (Westinghouse Electric)
Mfr. P/N - 997J036-1
Serial No. - WRDC-01
Rating - 22.5/30 KW, 270 Vdc

Generator Control Unit (Westinghouse Electric)
Mfr. P/N - ED427282-1
Serial No. - WRDC-01

Figure 10 is a photograph of the generator system under test mounted on the drive stand. Figure 11 is a reverse angle close-up of the generator mounted on the drive stand.

TEST SETUP

Figure 12 is a schematic of the generator system under test. The following is a listing of the contents of Figure 12.

1. DC Drive Motor
General Electric Model 350 hp
2. Speed Increasing Gearbox
General Electric 10,000 max output rpm

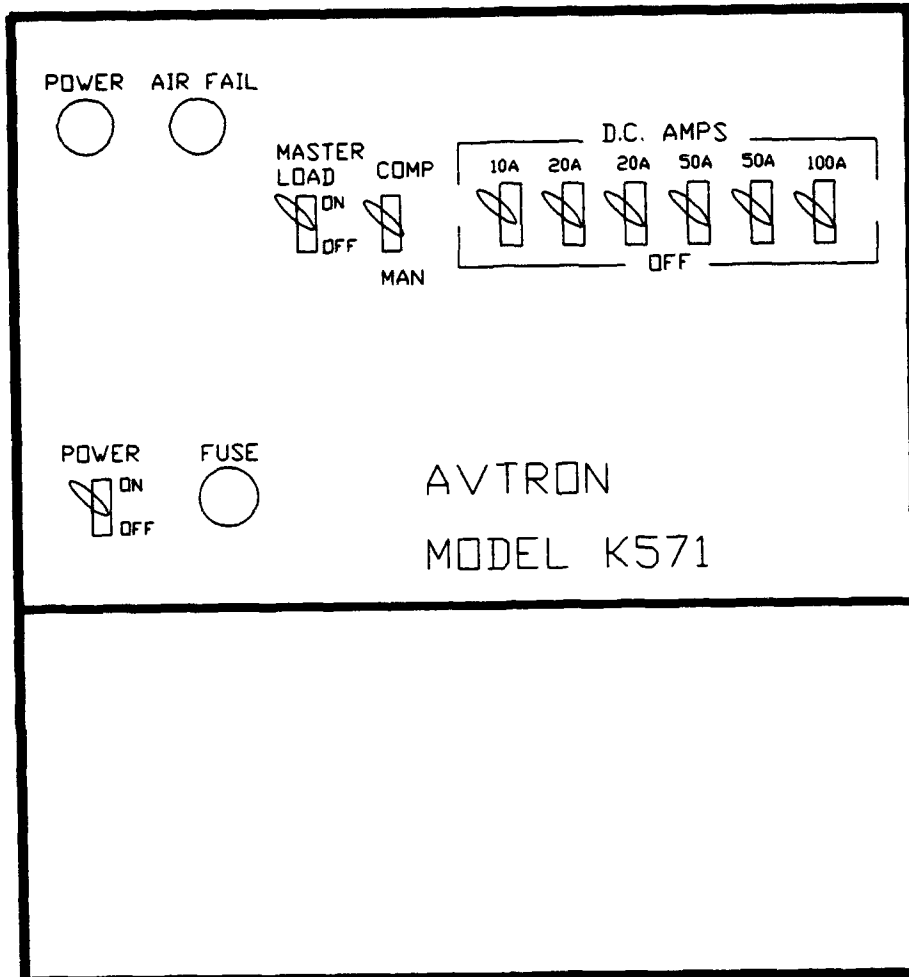

Figure 8
270 VDC LOAD BANK
MANUAL CONTROL PANEL

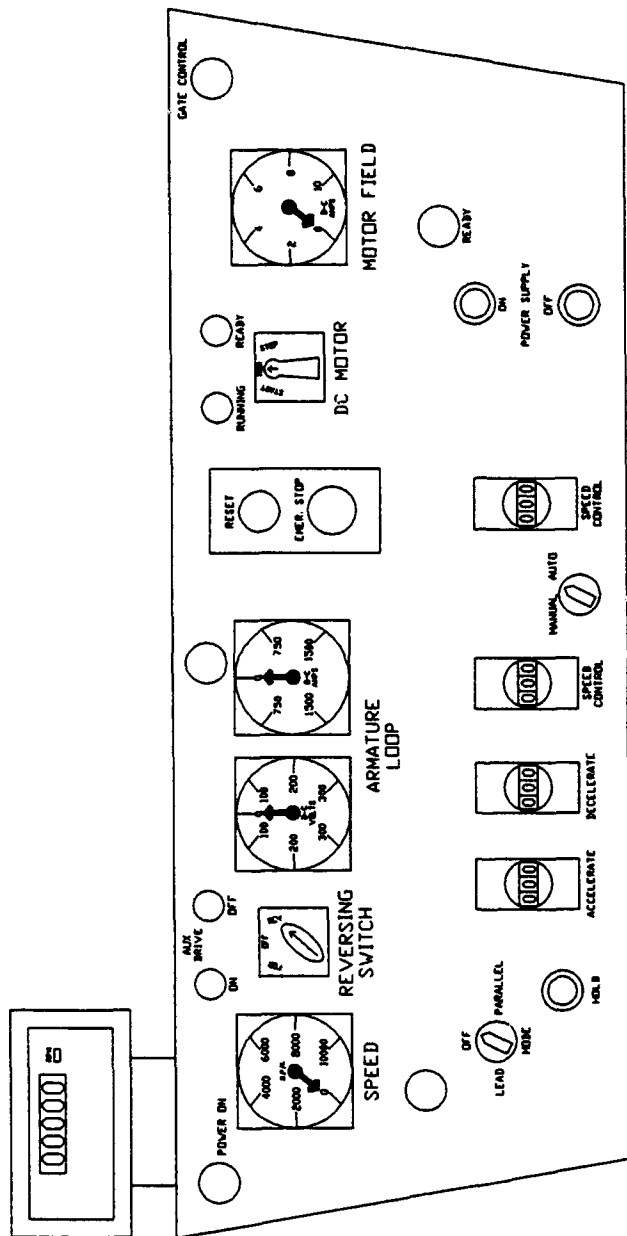

Figure 9

DRIVE STAND #3 CONTROL PANEL

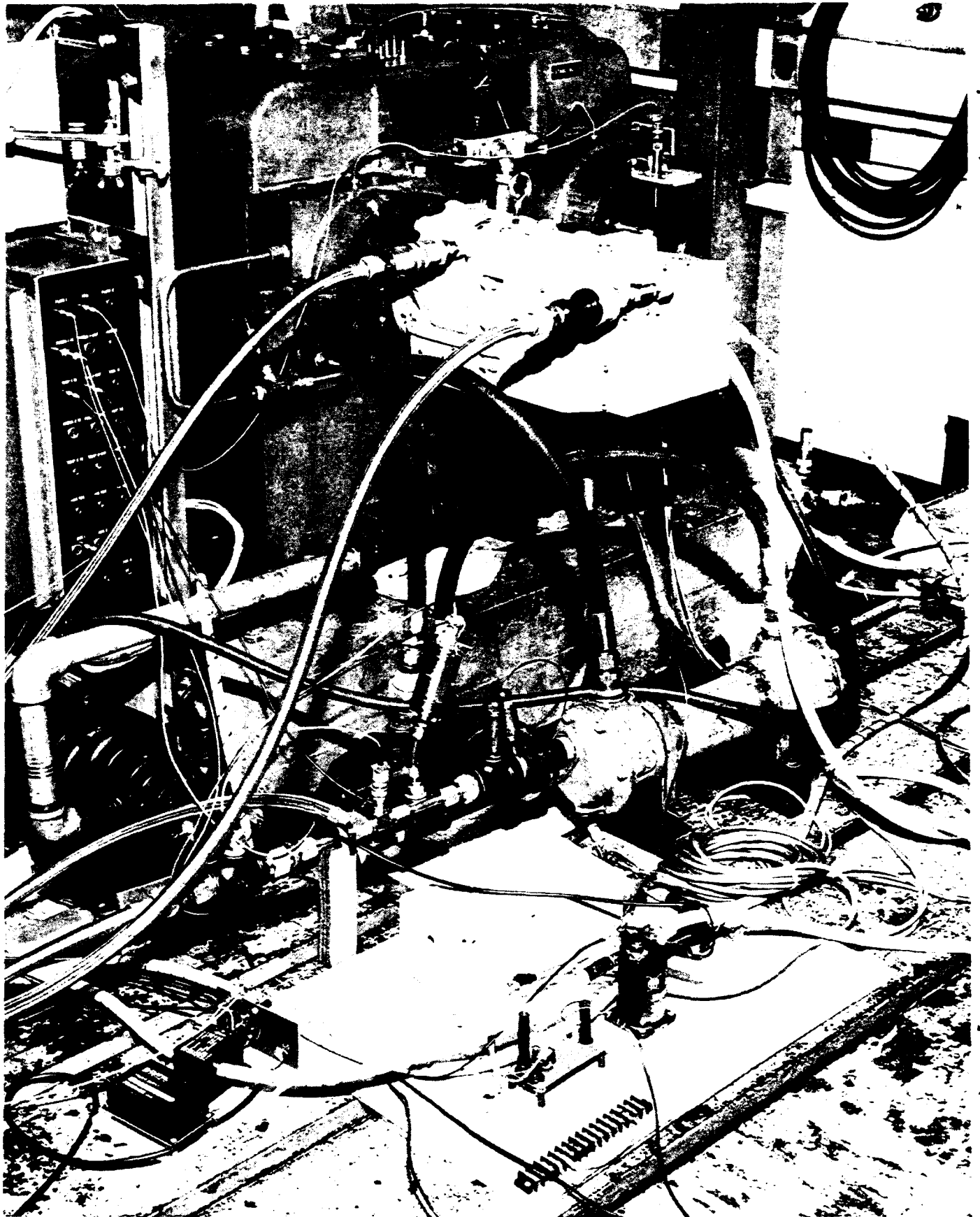

Figure 10: Generator System Under Test

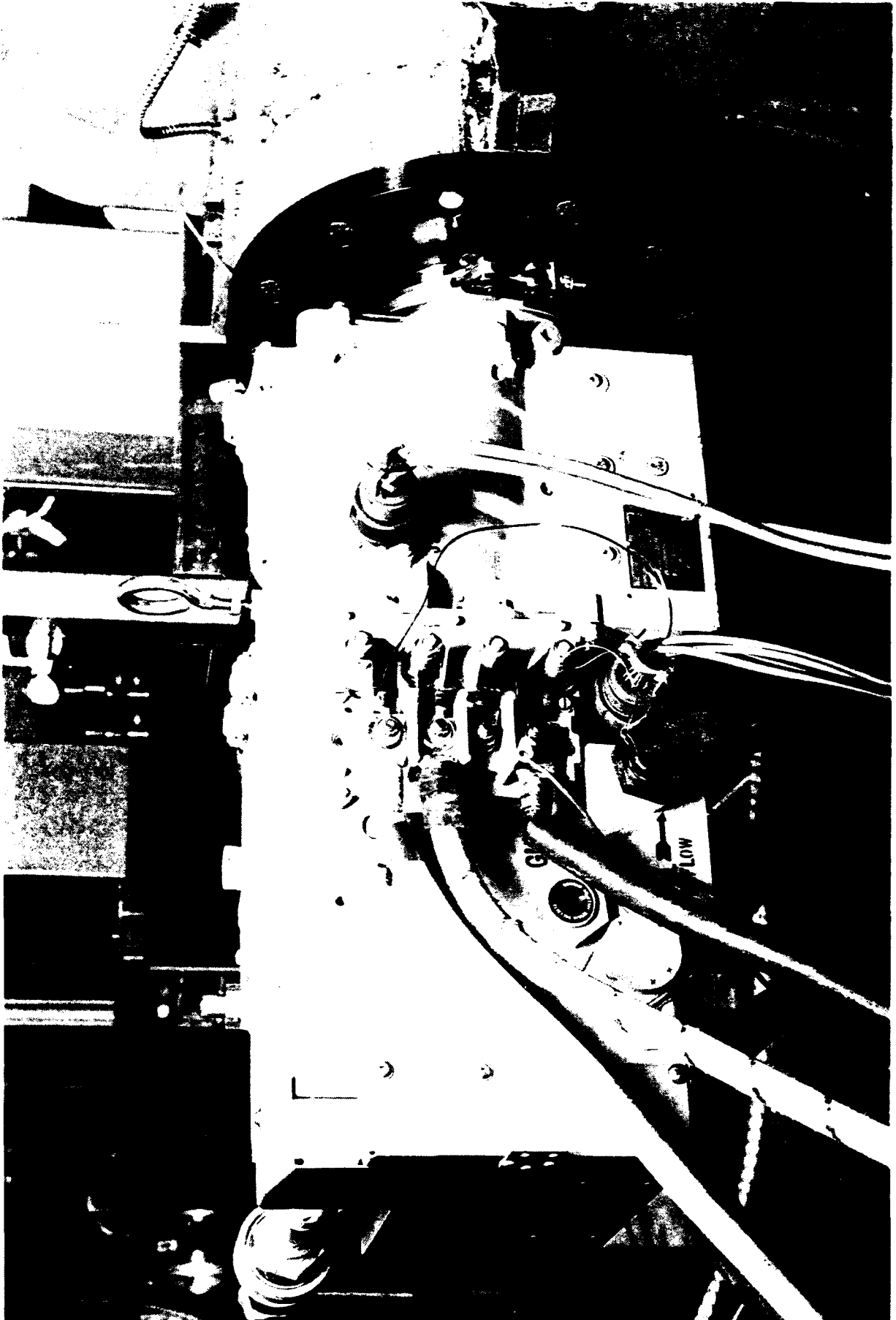

Figure 11: Reverse Angle Generator Close-up

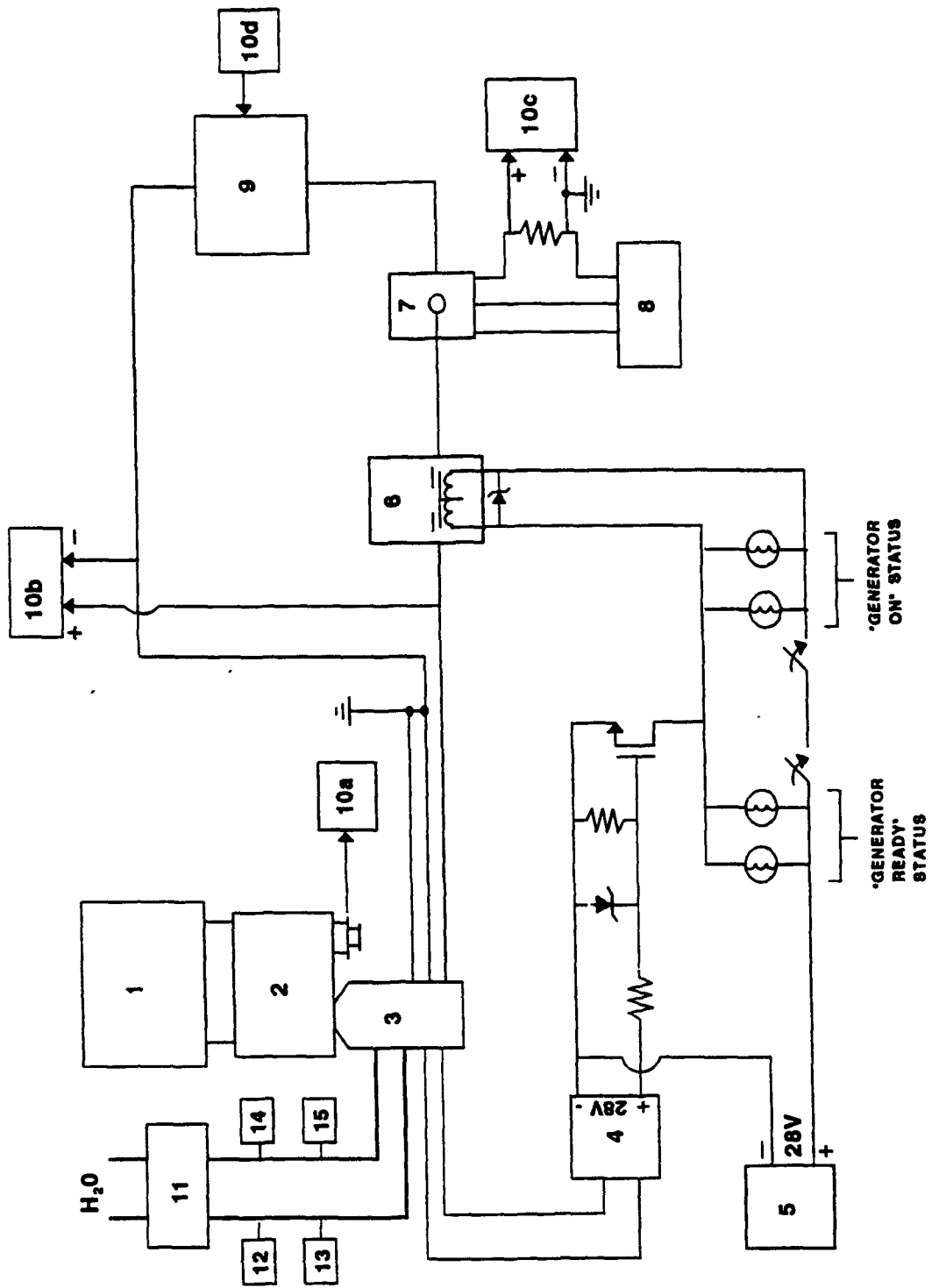

Figure 12
TEST SETUP

3. 22.5/30 KW 270 Vdc Generator Under Test
Westinghouse P/N 997J036-1
4. Generator Control Unit
Westinghouse P/N ED427282-1
5. 28 Vdc Power Supply
Kepco P/N BOP36-5-M
6. Contactor
Kilovac P/N AP150X854 (Czonka)
7. Hall Effect Current Sensor
LEM P/N LT300-S
8. 15 Vdc Bipolar Power Supply
DATEL P/N BPM 15/200
9. 250 A, 270 Vdc Load Bank
Avtron P/N K571D19279
- 10a. Data Acquisition System rpm Sense Input
- 10b. Data Acquisition System Volt Sense Input
- 10c. Data Acquisition System Current Sense Input
- 10d. Data Acquisition System Load Bank Control
11. Heat Exchanger
Perfex P/N B-415-422
12. Generator Oil "Out" Temperature Sensor
YSI-YOSTMAN
13. Generator Oil Flow Transducer
P/N WPAF-10
14. Generator Oil "In" Temperature Sensor
YSI-YOSTMAN
15. Generator Oil "In" Pressure Transducer
BLH P/N 416088

SECTION 3

TEST RESULTS

Test sequences are described in Appendix A. Appendix B is the computer log of the test sequence executions and includes the actual test sequences in data file format. This section will describe the results of the test sequence executions

TRANSIENT CHARACTERISTICS

Generator transient responses were measured for various resistive load applications and removals at the rated low and high ends of the generator input speed range. Transient responses were measured as described in Appendix A for 20 A, 50 A, 80 A, 100 A, 110 A, 120 A (1.5 per unit), and 160 A (2.0 per unit) and the results can be seen in Figures 13 - 54. Figures 13 - 26 show the entire test sequences as they were executed. Figures 27 - 40 show the transients for load applications and load removals grouped for each load with the generator speed set to 4000 rpm. Figures 41 - 54 are the same as figures 27 - 40 with generator speed set to 8200 rpm. Transient voltage maximums and minimums and response times are illustrated in Figures 27 - 54 are summarized in Tables 1 and 2. The voltages are the extreme voltage values resulting from the load application (minimum voltage) or removal (maximum voltage). Response time is defined as the time measured for the generator voltage to reach steady state after initialization of a load application or removal. These results were compared to the transient limits specified in MIL-STD-704E and the generator met these limits in most cases. The MIL-STD-704E limits have been superimposed onto Figures 40, 47, 48, 49, 50, 52, and 54 where the generator voltage spikes exceeded the specified transient limit envelope for that particular test sequence. This type of voltage spike is defined as an abnormal transient. Note that most of these abnormal transients are a result of overloads and the abnormal transients become more frequent with the high (8200 rpm) generator speeds. Overload applications did not cause abnormal transients since overloads were applied by removal of some load before application of the overload as can be seen in figures 37, 39, 51, and 53. Also note that voltage and current spikes observed prior to the actual load transients in Figures 27 - 54 are glitches in the data acquisition system and should be ignored.

Table 1: Load Application Transients

Applied Load (Amps)	Generator Speed = 4000 rpm		Generator Speed = 8200 rpm	
	Recovery Time (ms)	Minimum Voltage (V)	Recovery Time (ms)	Minimum Voltage (V)
20	11.8	236	7.4	234
50	13.6	206	10.2	233
80	15.8	221	10.3	214
100	18.0	212	11.3	197
110	16.0	222	9.7	197
120 (1.5 pu)	20.2	225	10.3	209
160 (2.0 pu)	24.4	230	12.6	226

Table 2: Load Removal Transients

Removed Load (Amps)	Generator Speed = 4000 rpm		Generator Speed = 8200 rpm	
	Recovery Time (ms)	Maximum Voltage (V)	Recovery Time (ms)	Maximum Voltage (V)
20	10.8	290	9.3	291
50	29.8	299	21.6	309
80	33.1	310	22.0	326
100	32.0	322	24.6	339
110	32.0	325	27.5	342
120 (1.5 pu)	32.7	324	27.4	341
160 (2.0 pu)	37.7	340	27.9	338

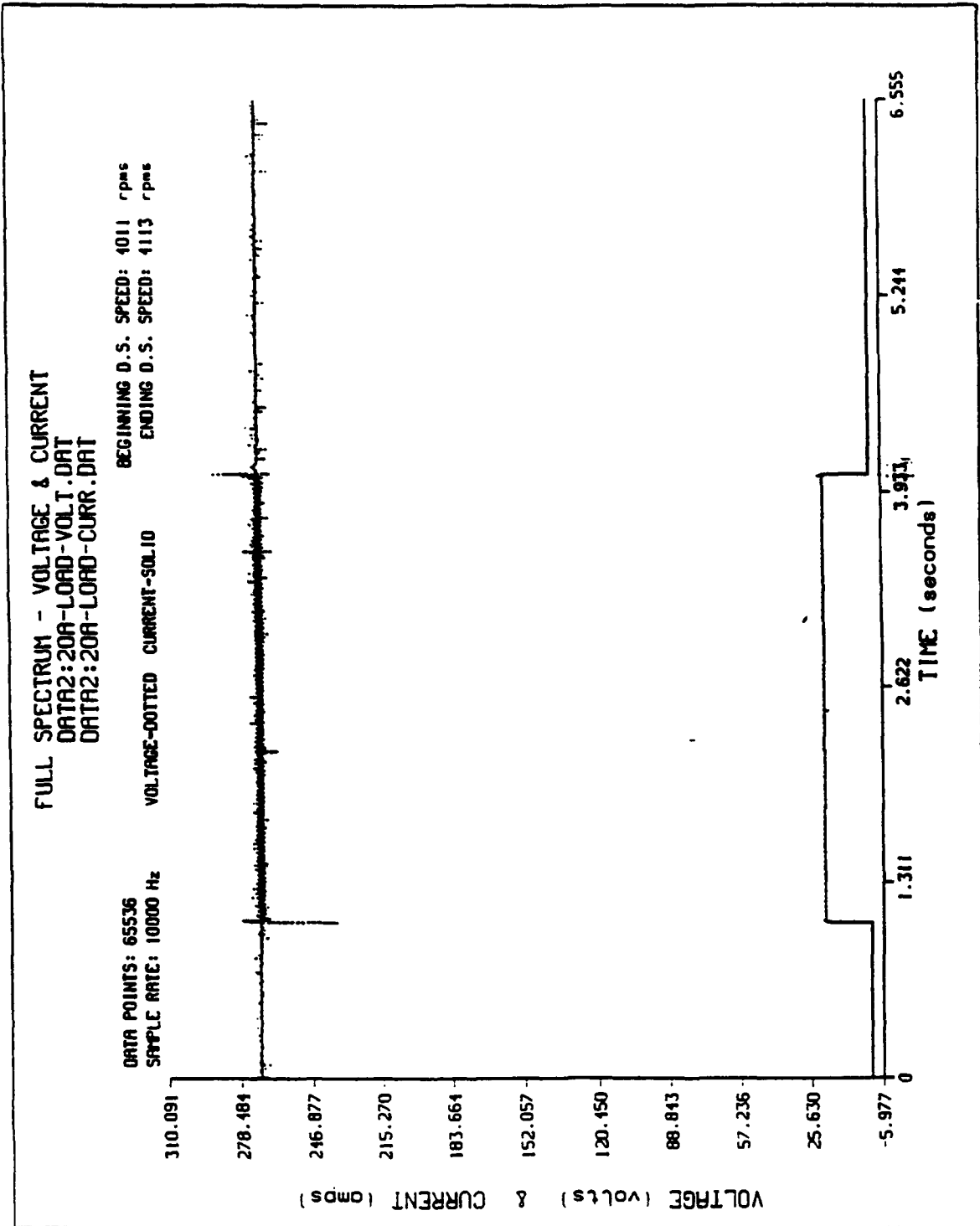

Figure 13: Load Application and Removal; 20 Amps, 4000 rpm

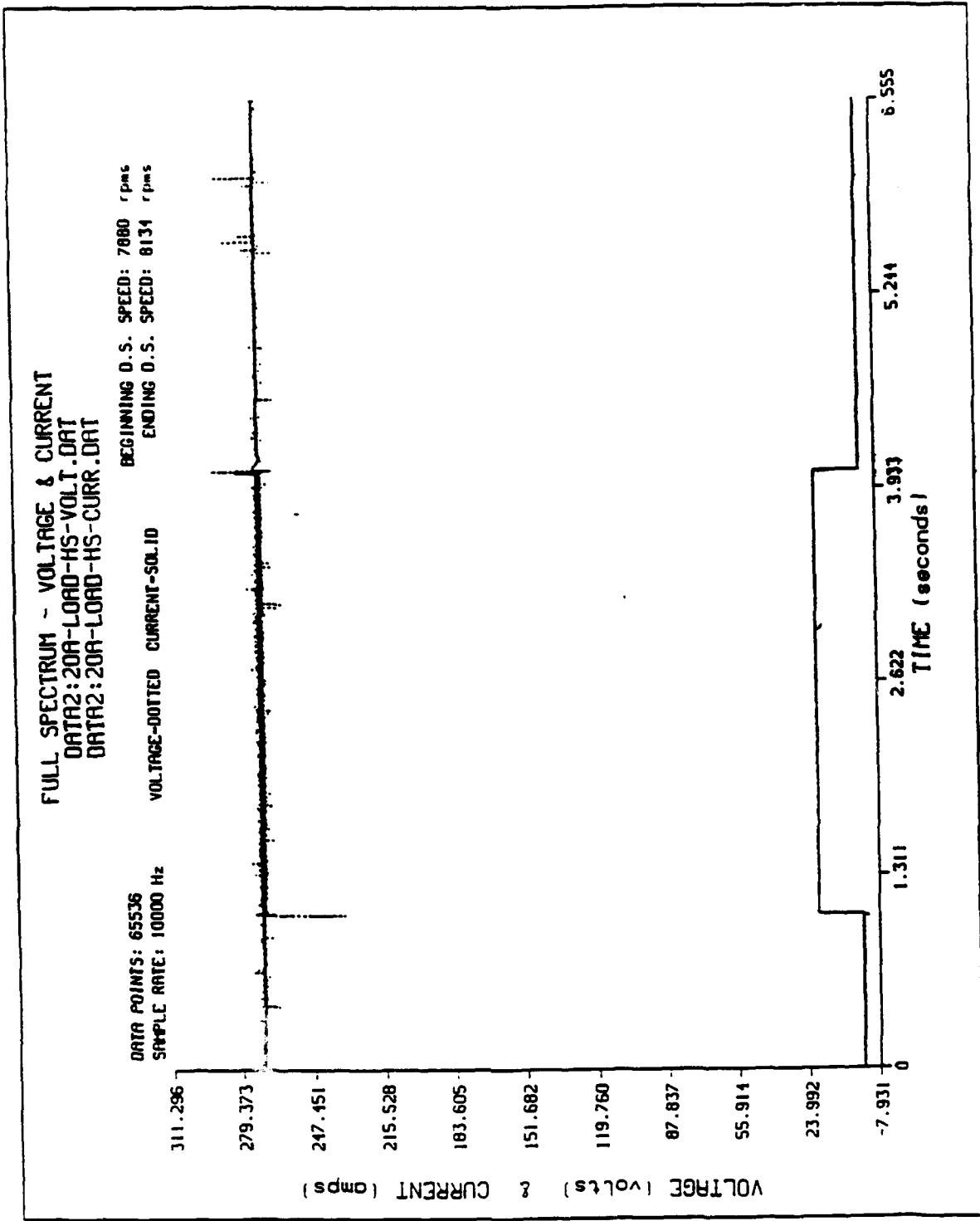

Figure 14: Load Application and Removal; 20 Amps, 8200 rpm

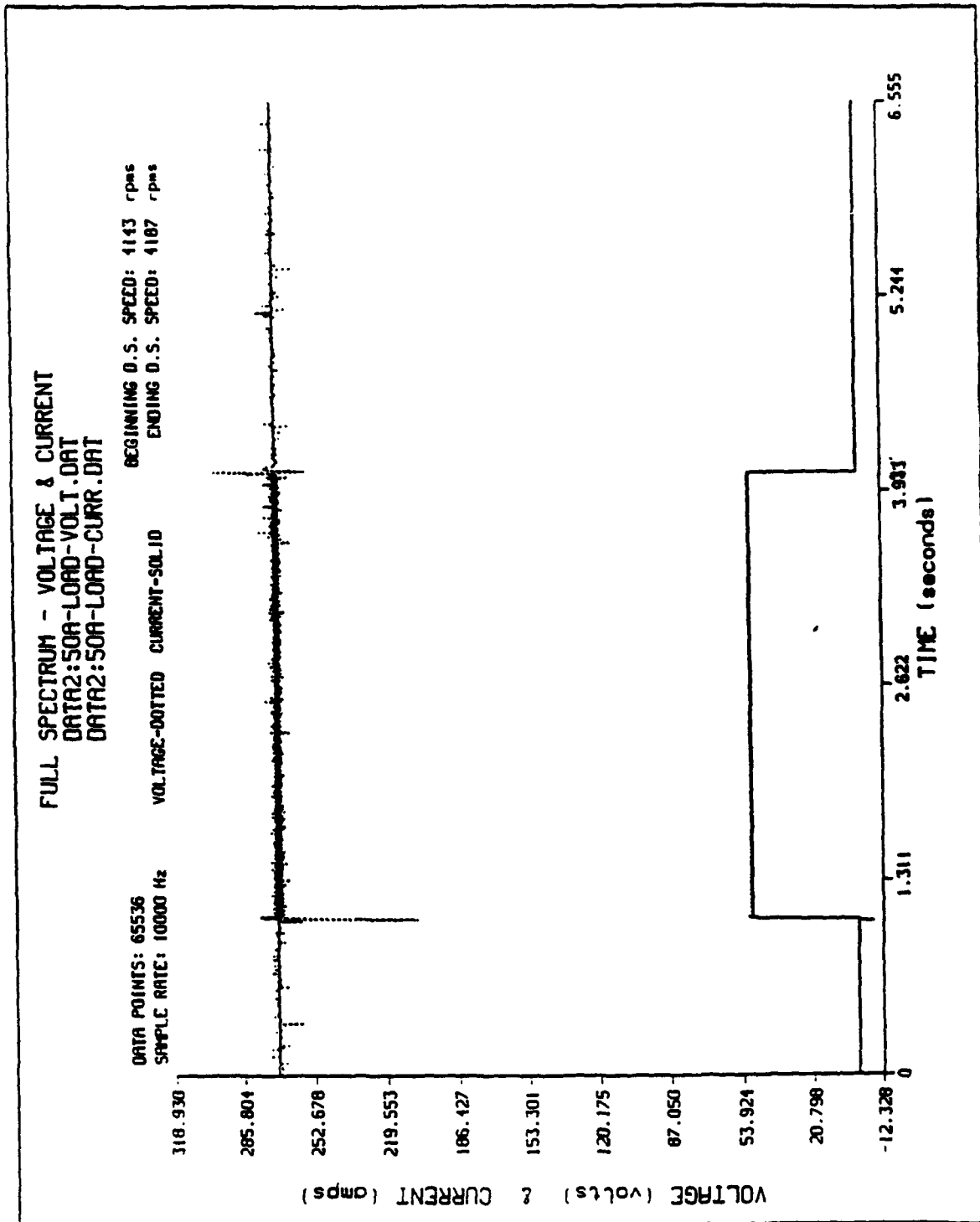

Figure 15: Load Application and Removal; 50 Amps, 4000 rpm

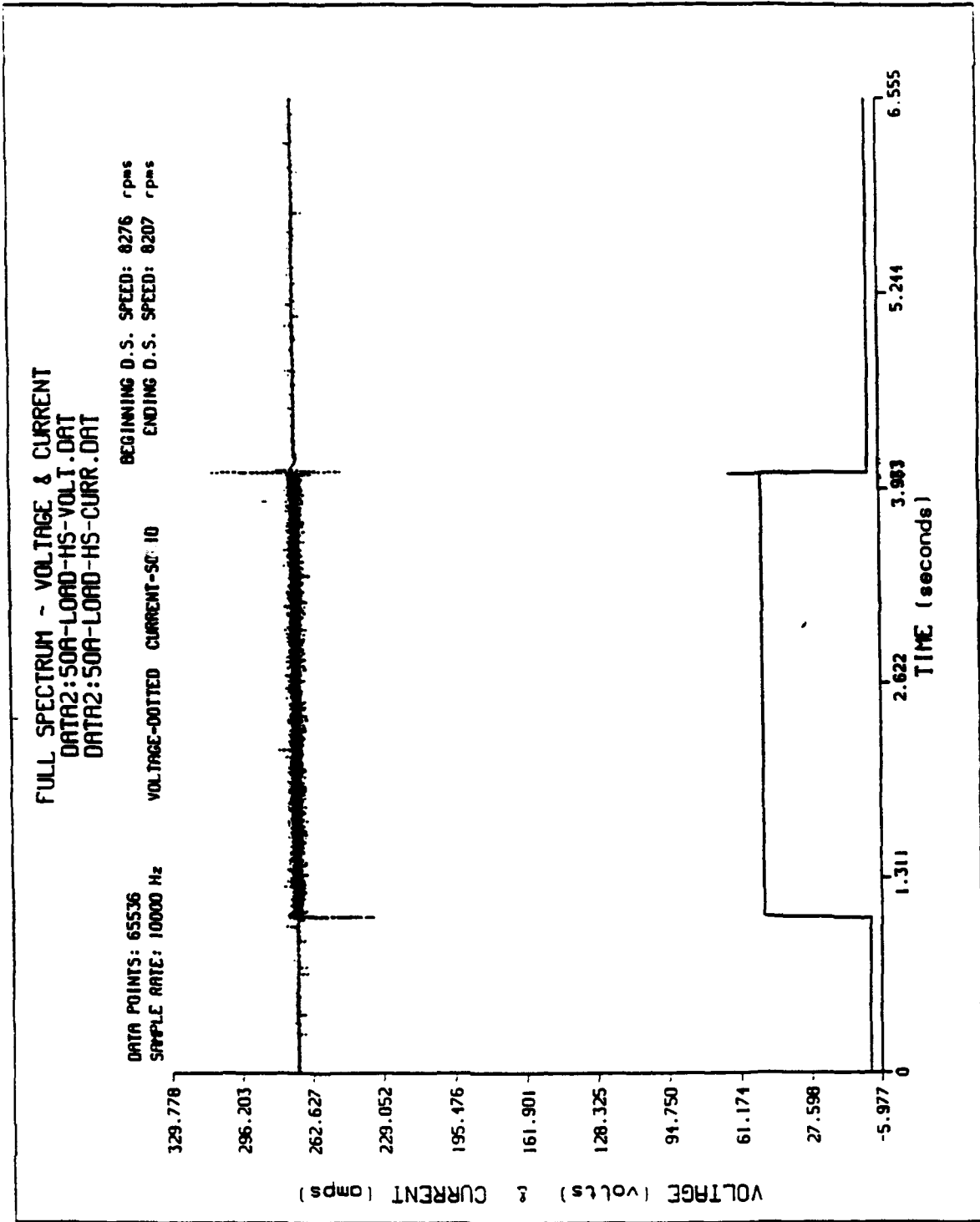

Figure 16: Load Application and Removal; 50 Amps, 8200 rpm

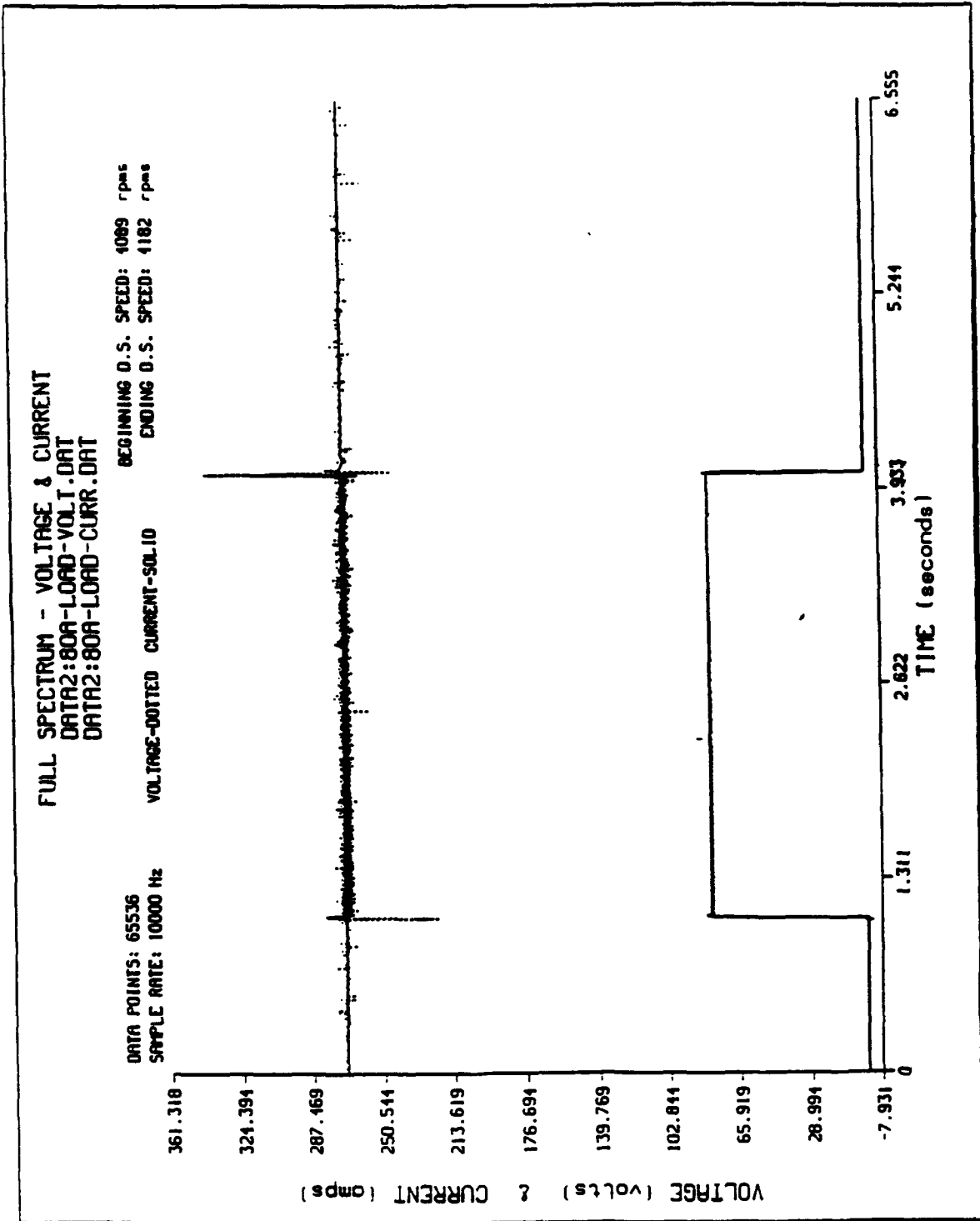

Figure 17: Load Application and Removal; 80 Amps, 4000 rpm

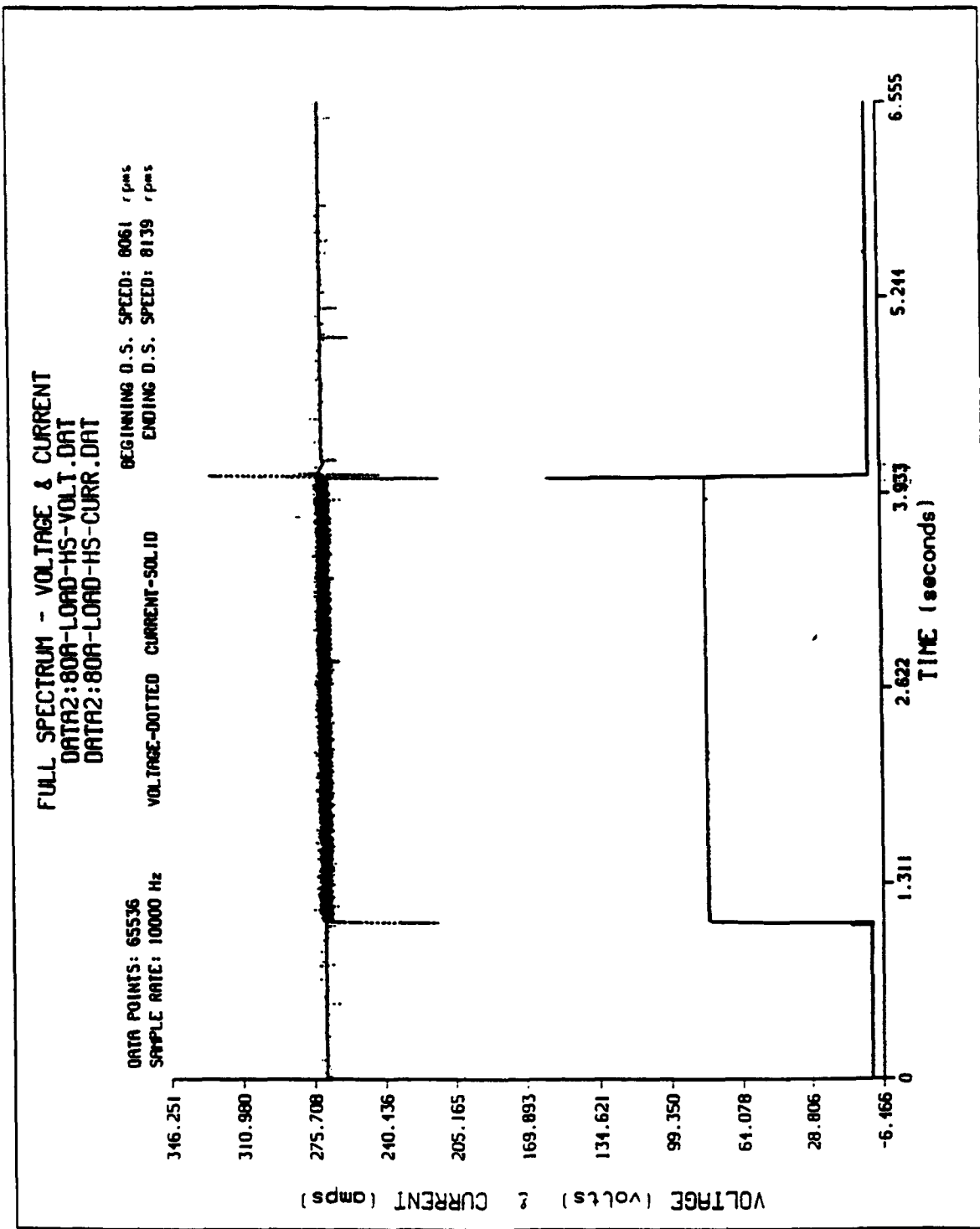

Figure 18: Load Application and Removal; 80 Amps, 8200 rpm

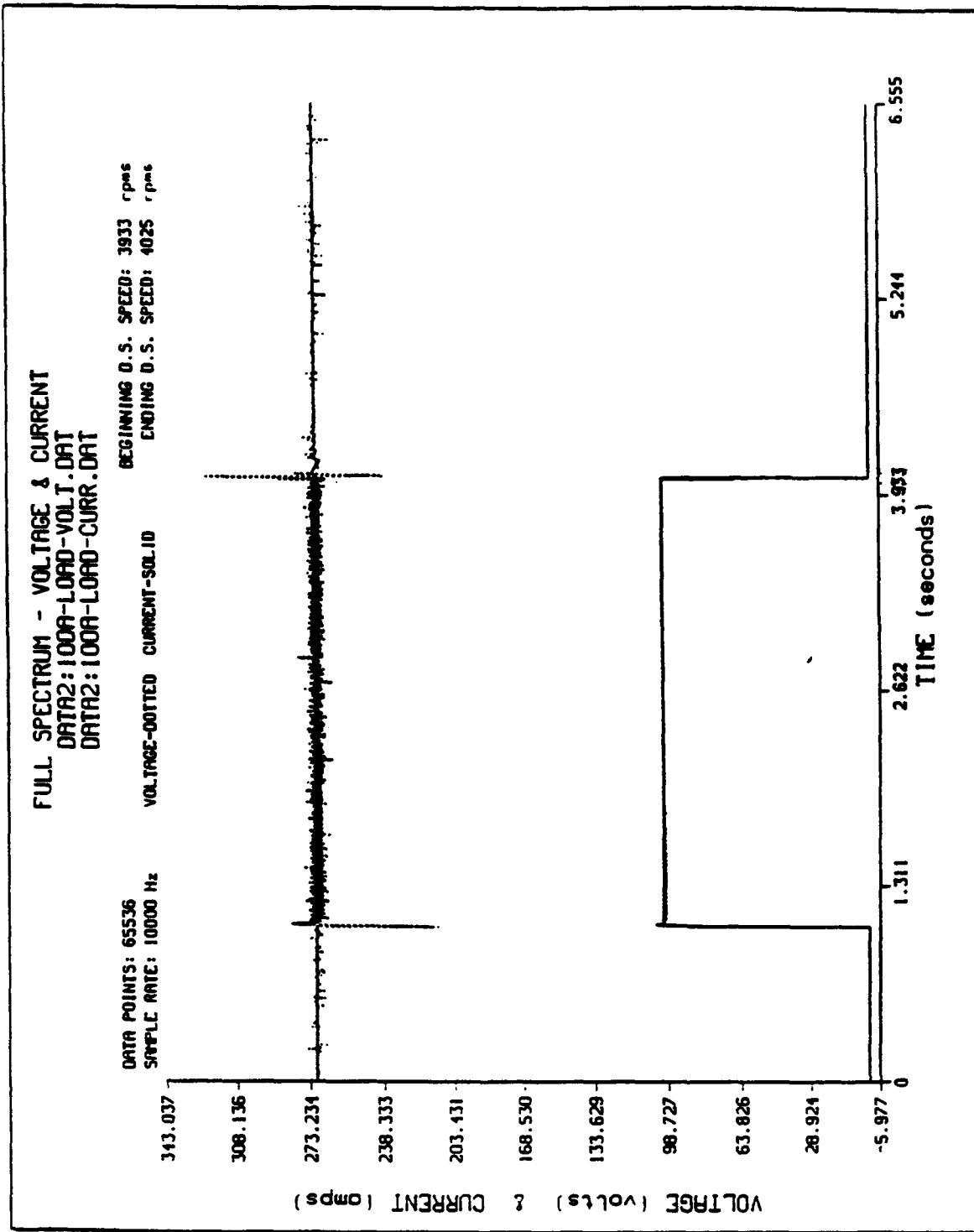

Figure 19: Load Application and Removal; 100 Amps, 4000 rpm

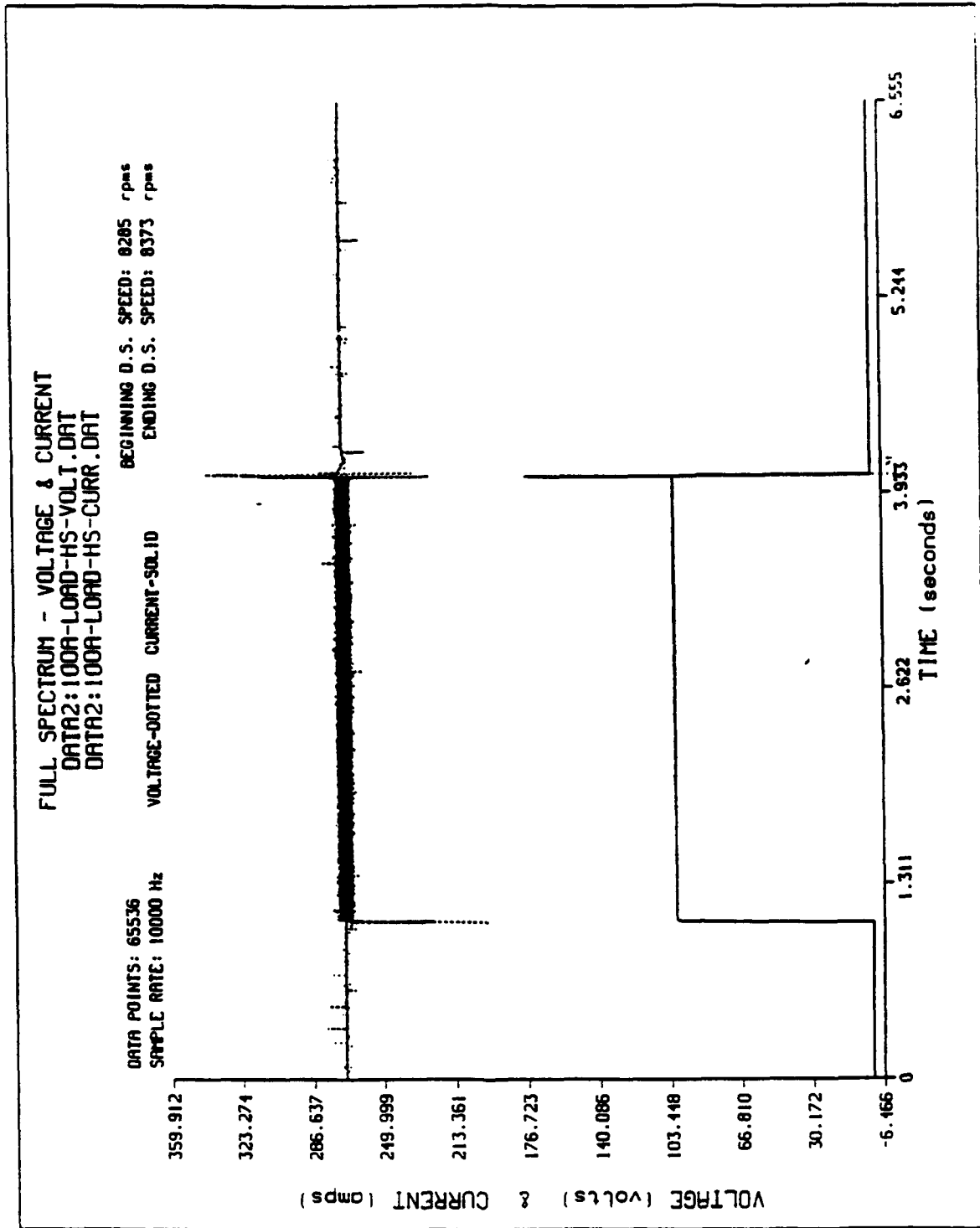

Figure 20: Load Application and Removal; 100 Amps, 8200 rpm

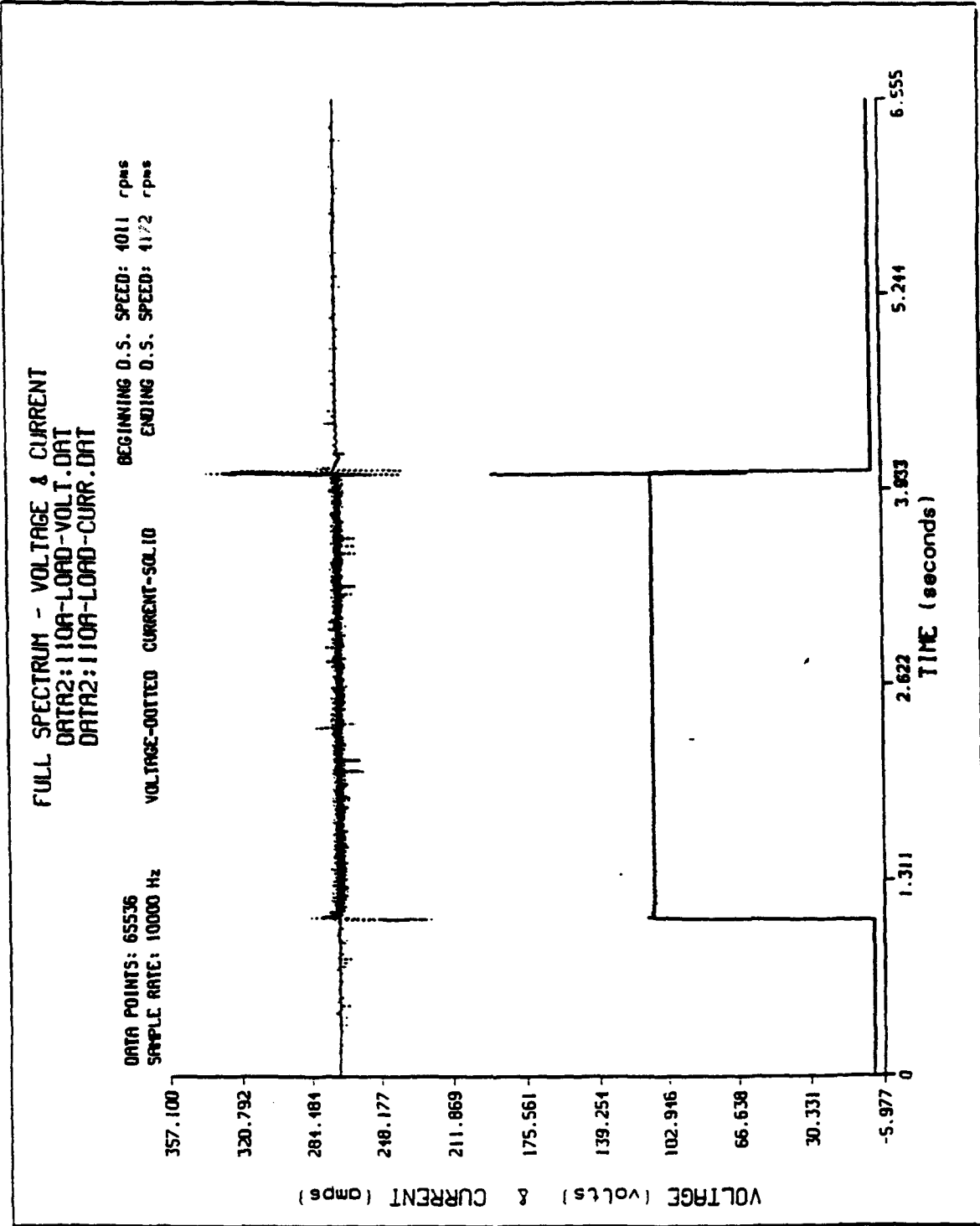

Figure 21: Load Application and Removal; 110 Amps, 4000 rpm

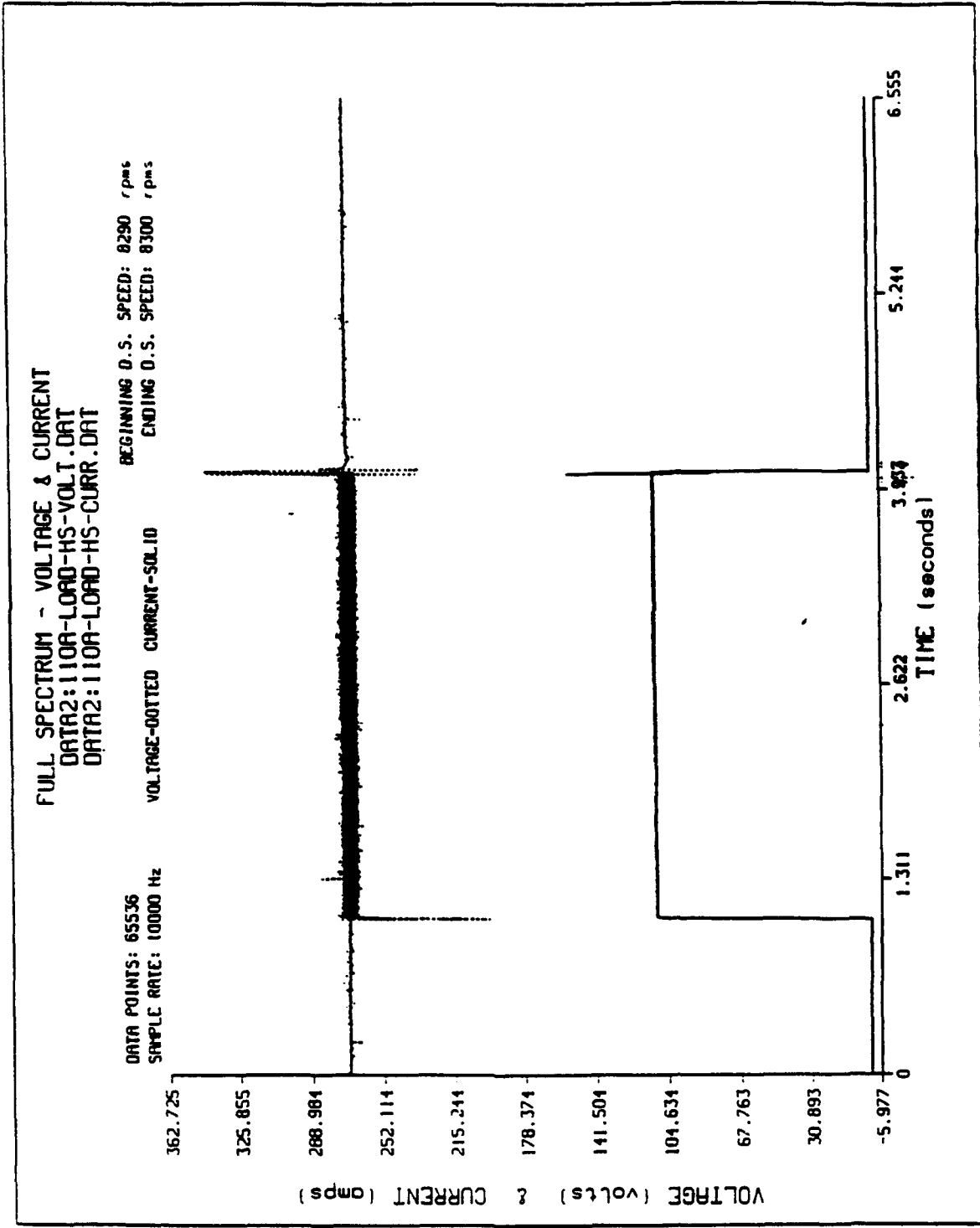

Figure 22: Load Application and Removal; 110 Amps, 8200 rpm

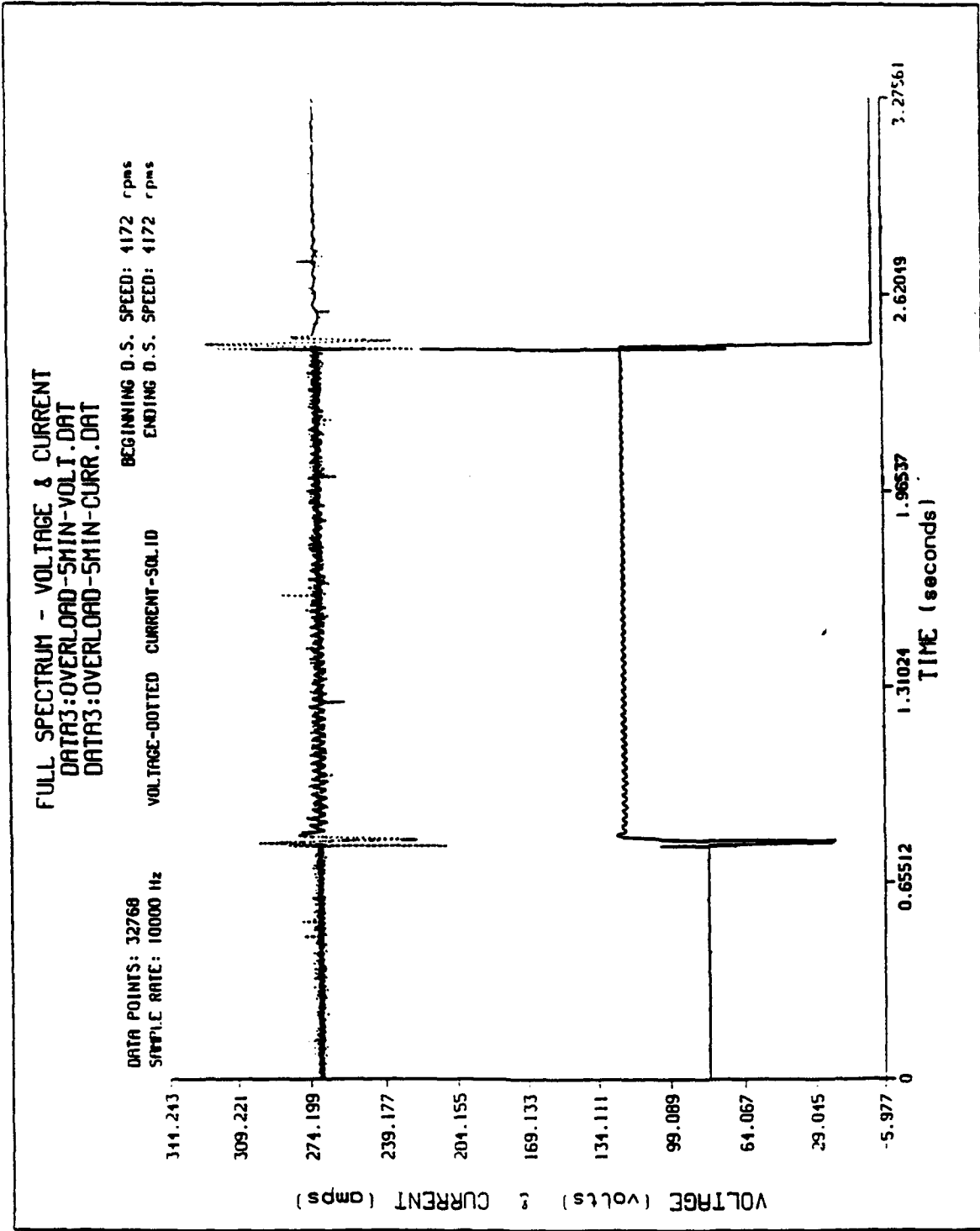

Figure 23: Overload (1.5 pu) Application and Removal, 120 Amps, 4000 rpm

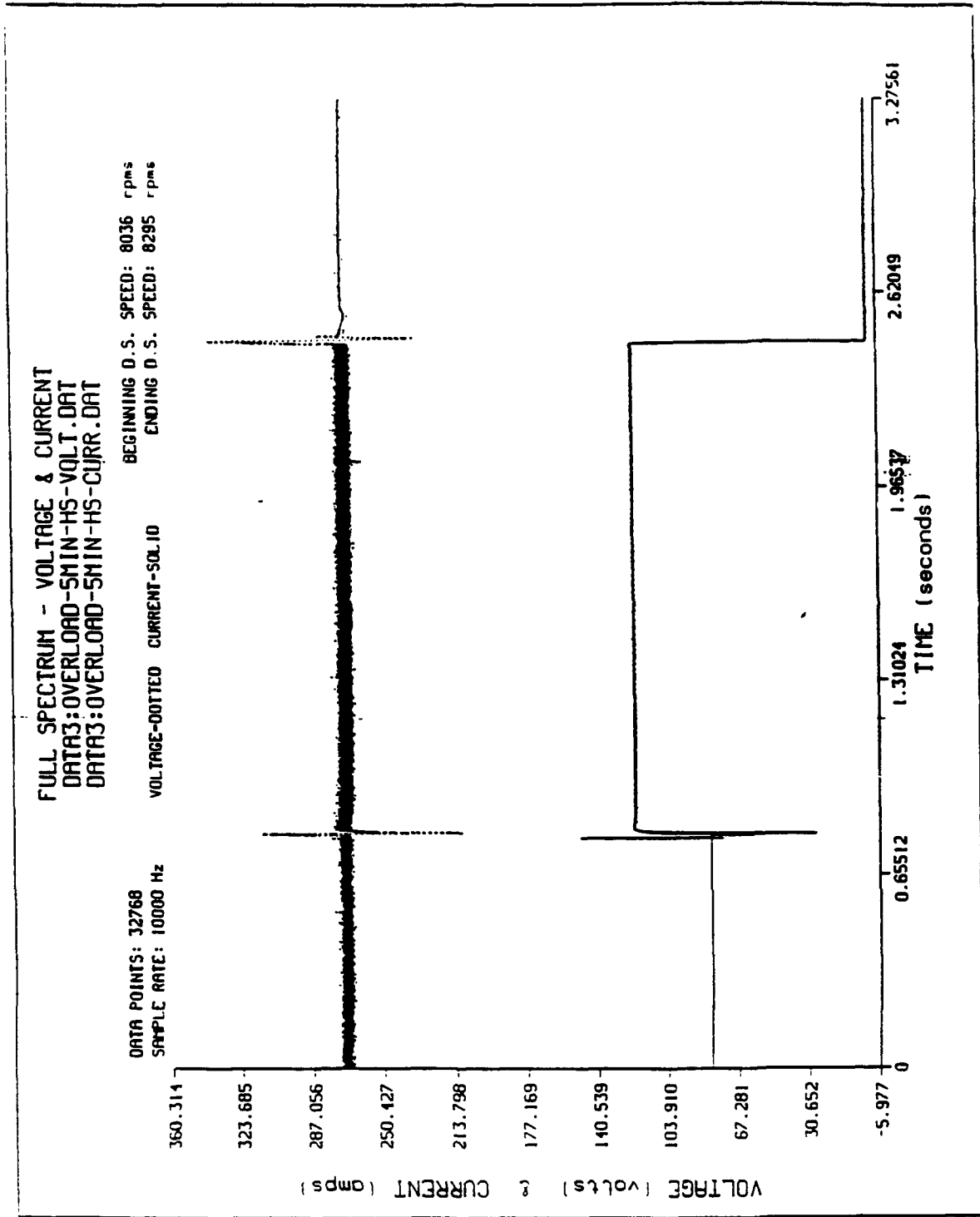

Figure 24: Overload (1.5 pu) Application and Removal; 120 Amps, 8200 rpm

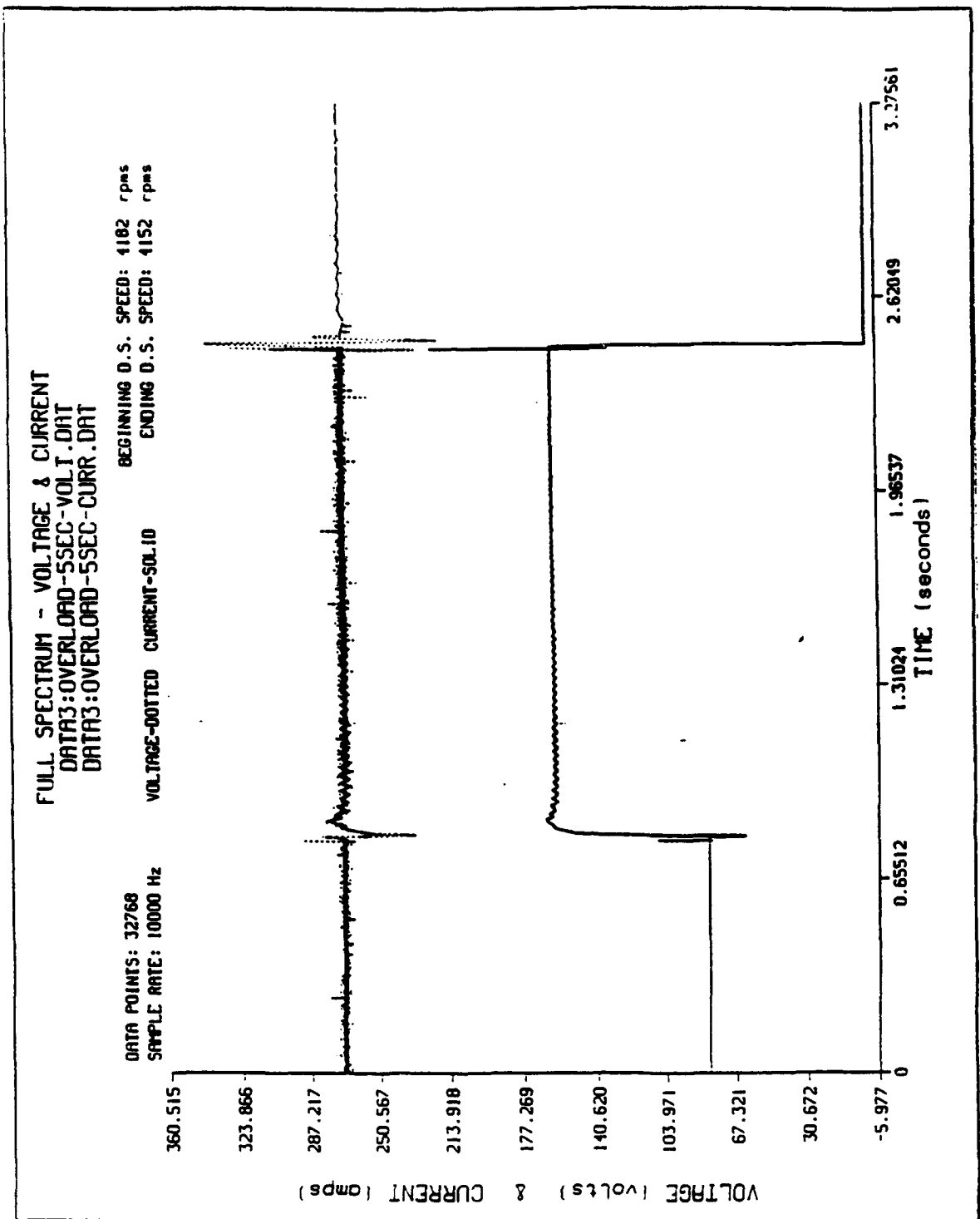

Figure 25: Overload (2.0 pu) Application and Removal; 160 Amps, 4000 rpm

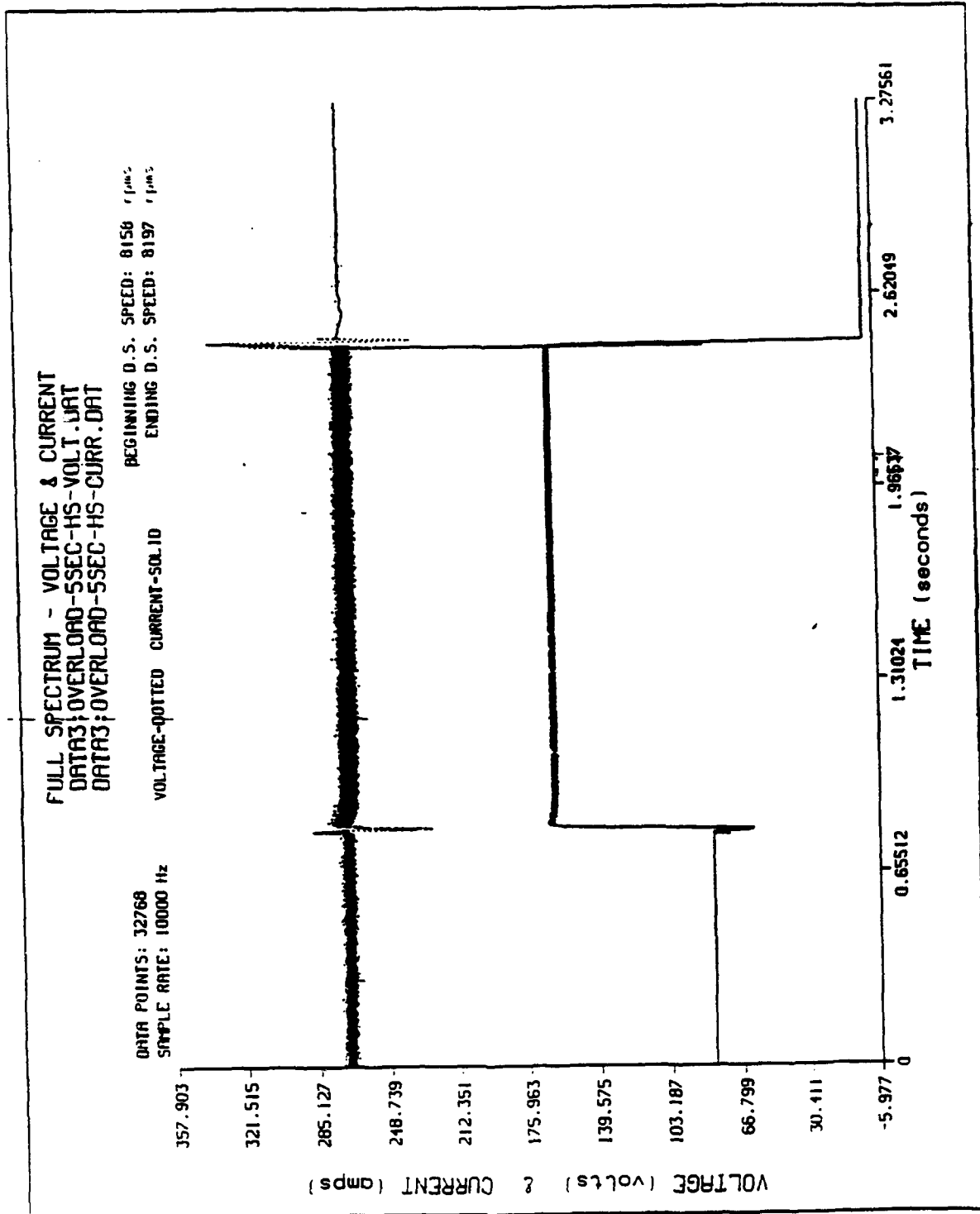

Figure 26: Overload (2.0 pu) Application and Removal; 160 Amps, 8200 rpm

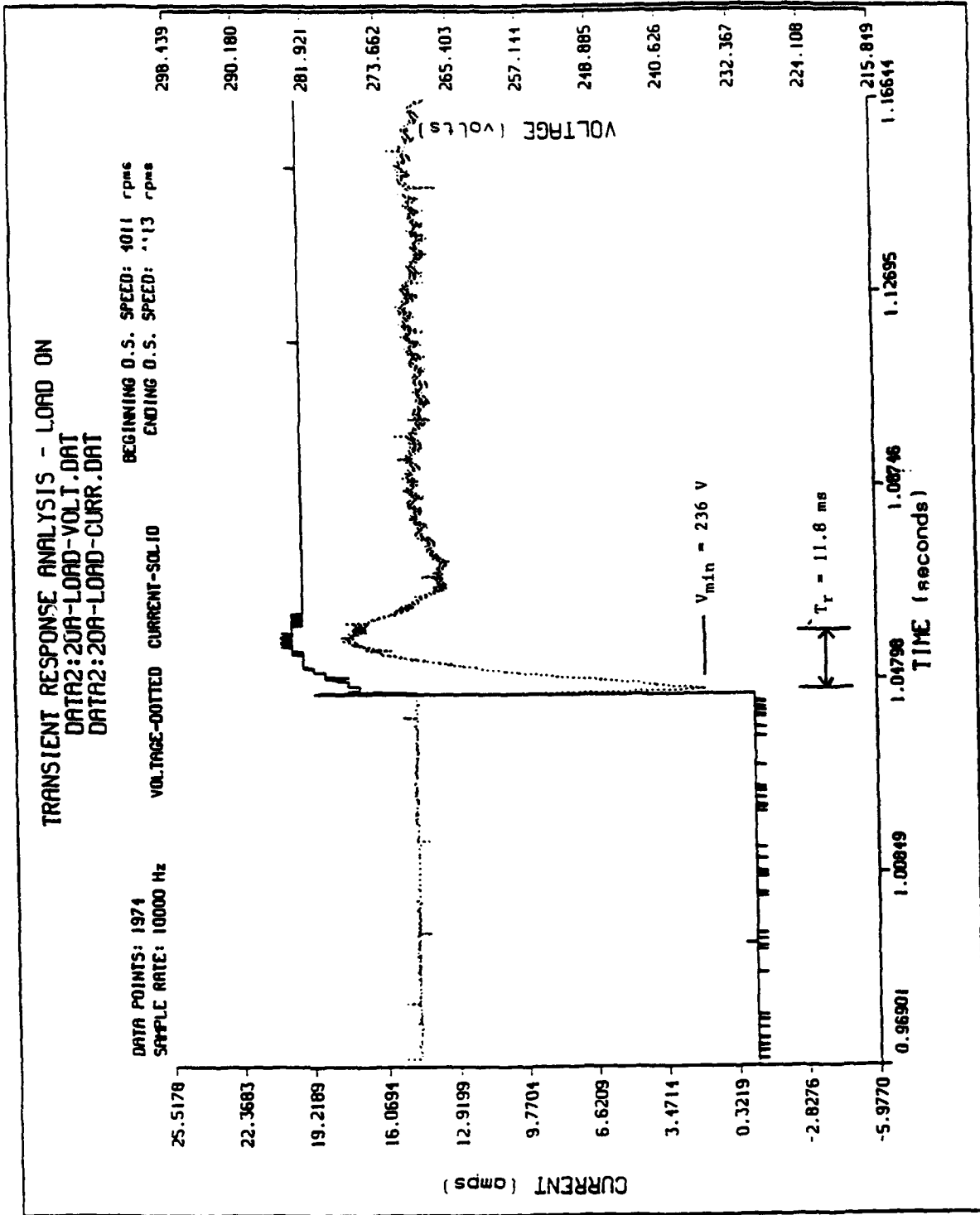

Figure 27: Load Application Transient, 20 Amps, (4000 rpm)

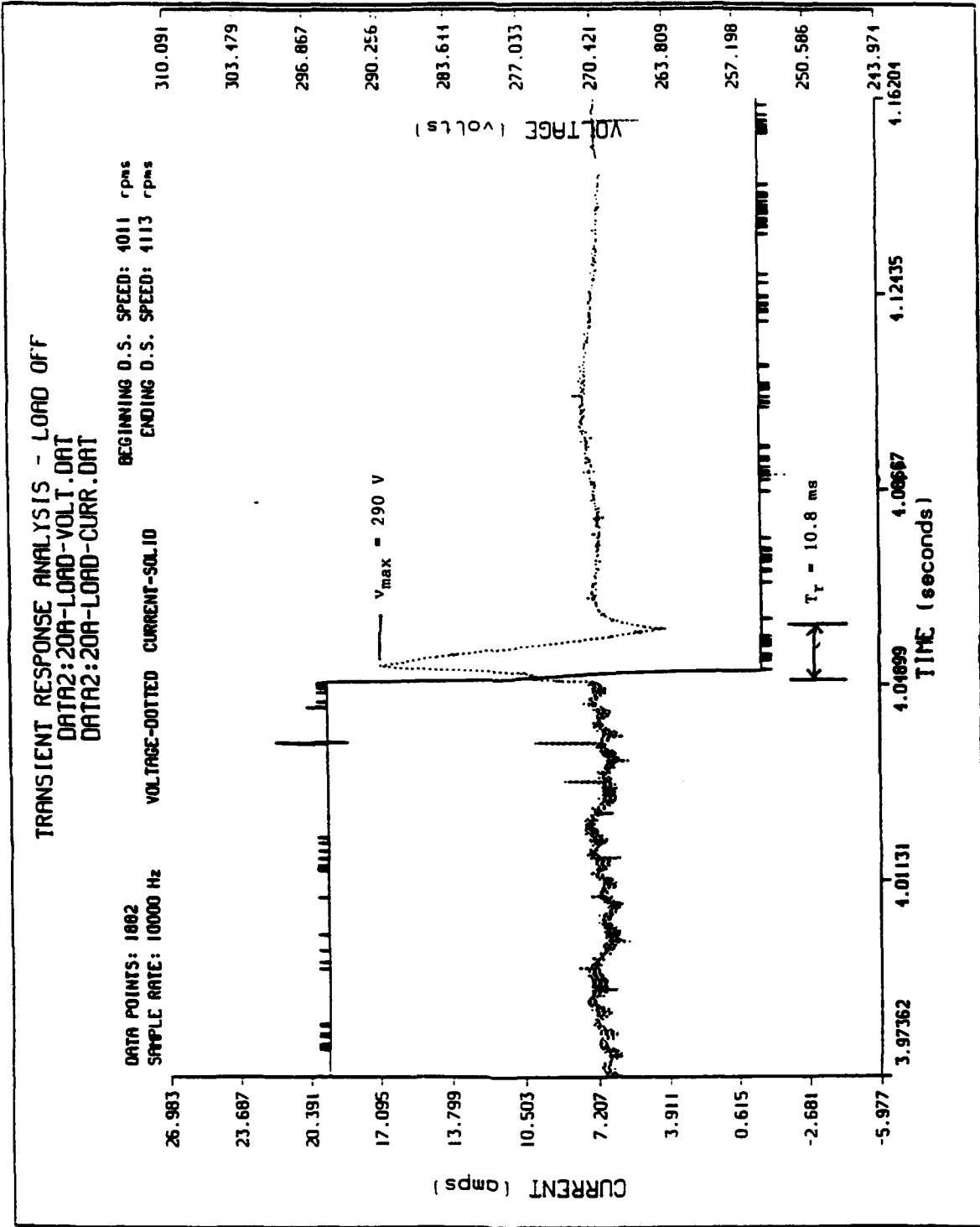

Figure 28: Load Removal Transient, 20 Amps, (4000 rpm)

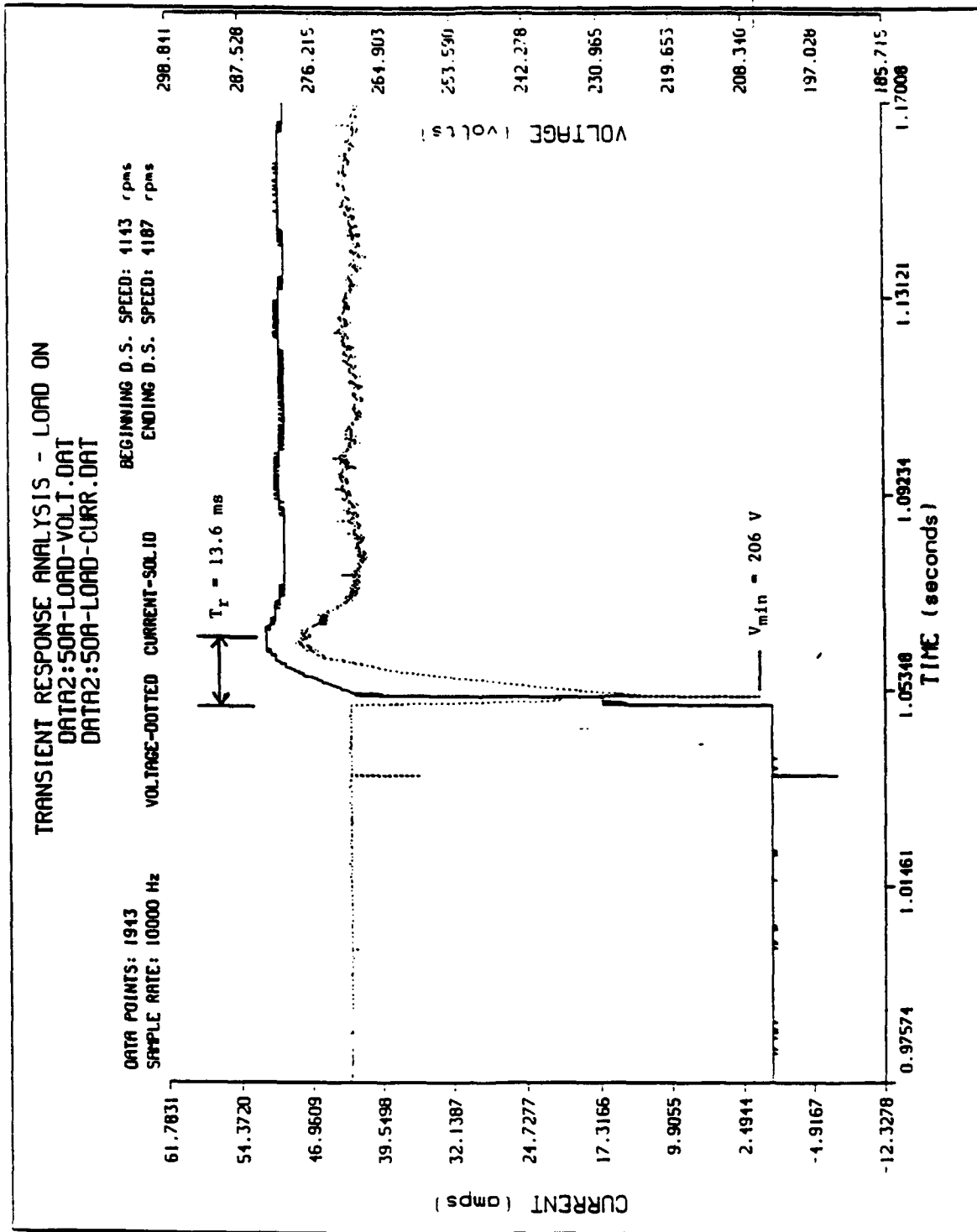

Figure 29: Load Application Transient; 50 Amps, (4000 rpm)

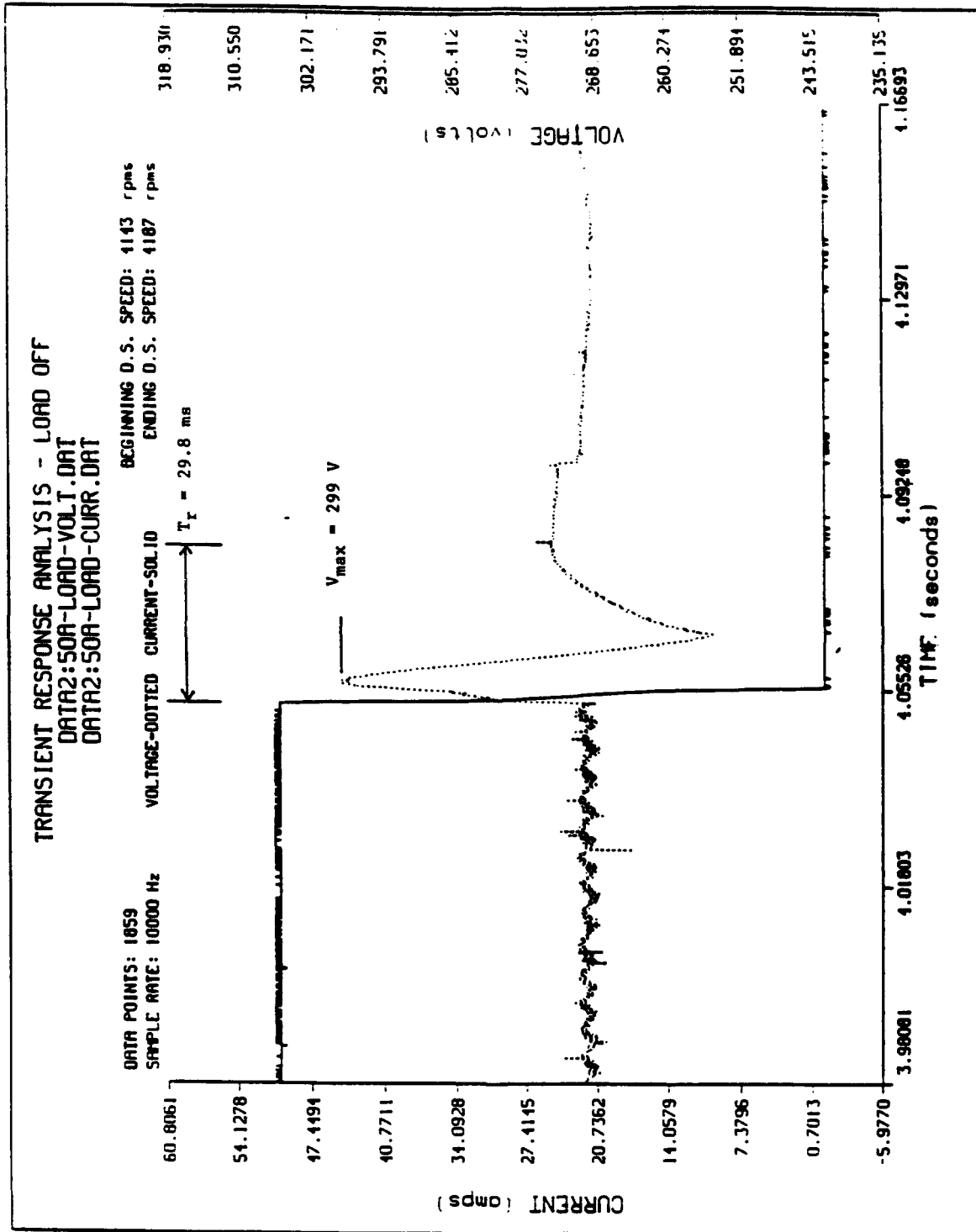

Figure 30: Load Removal Transient, 50 Amps, (4000 rpm)

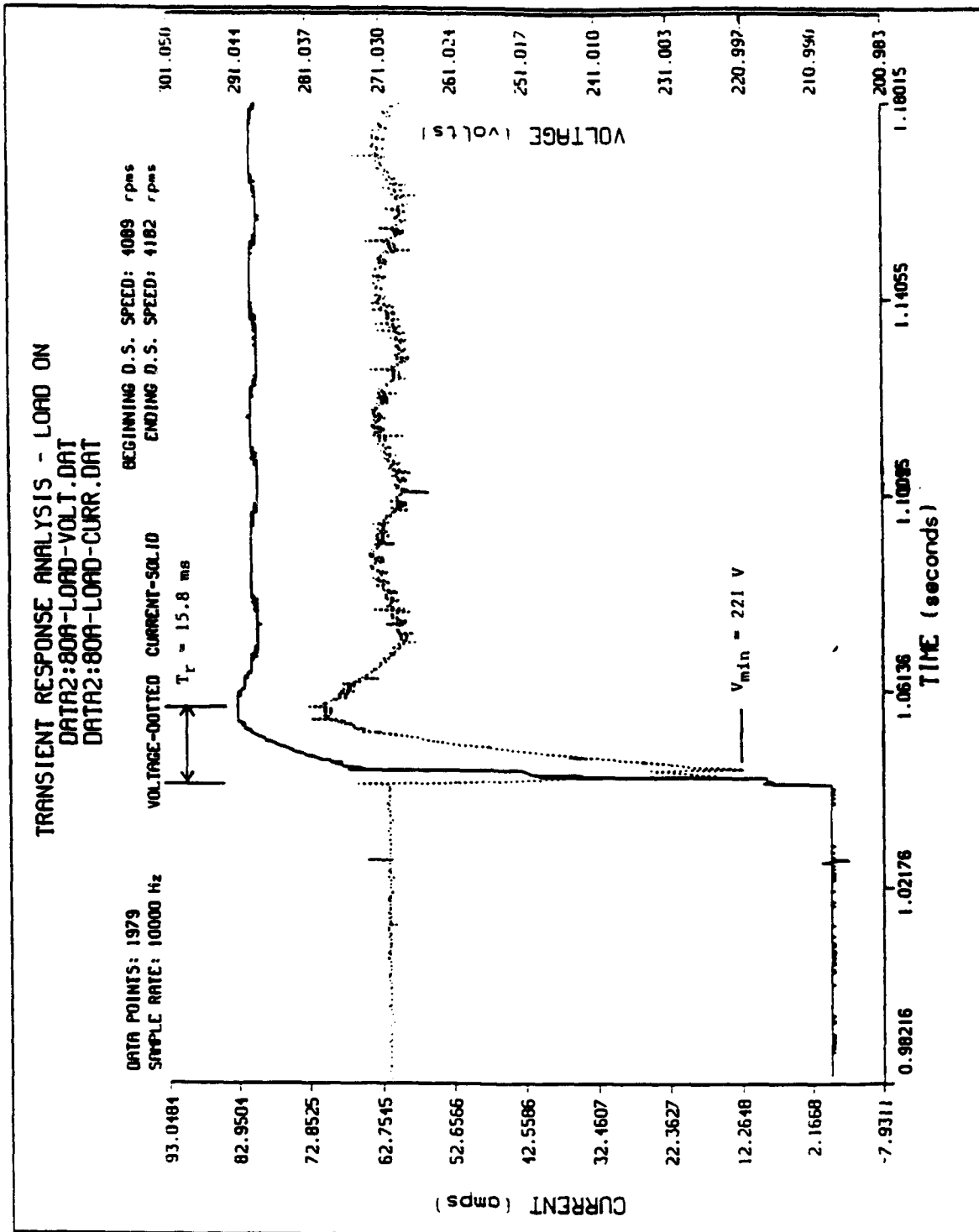

Figure 31: Load Application Transient; 80 Amps, (4000 rpm)

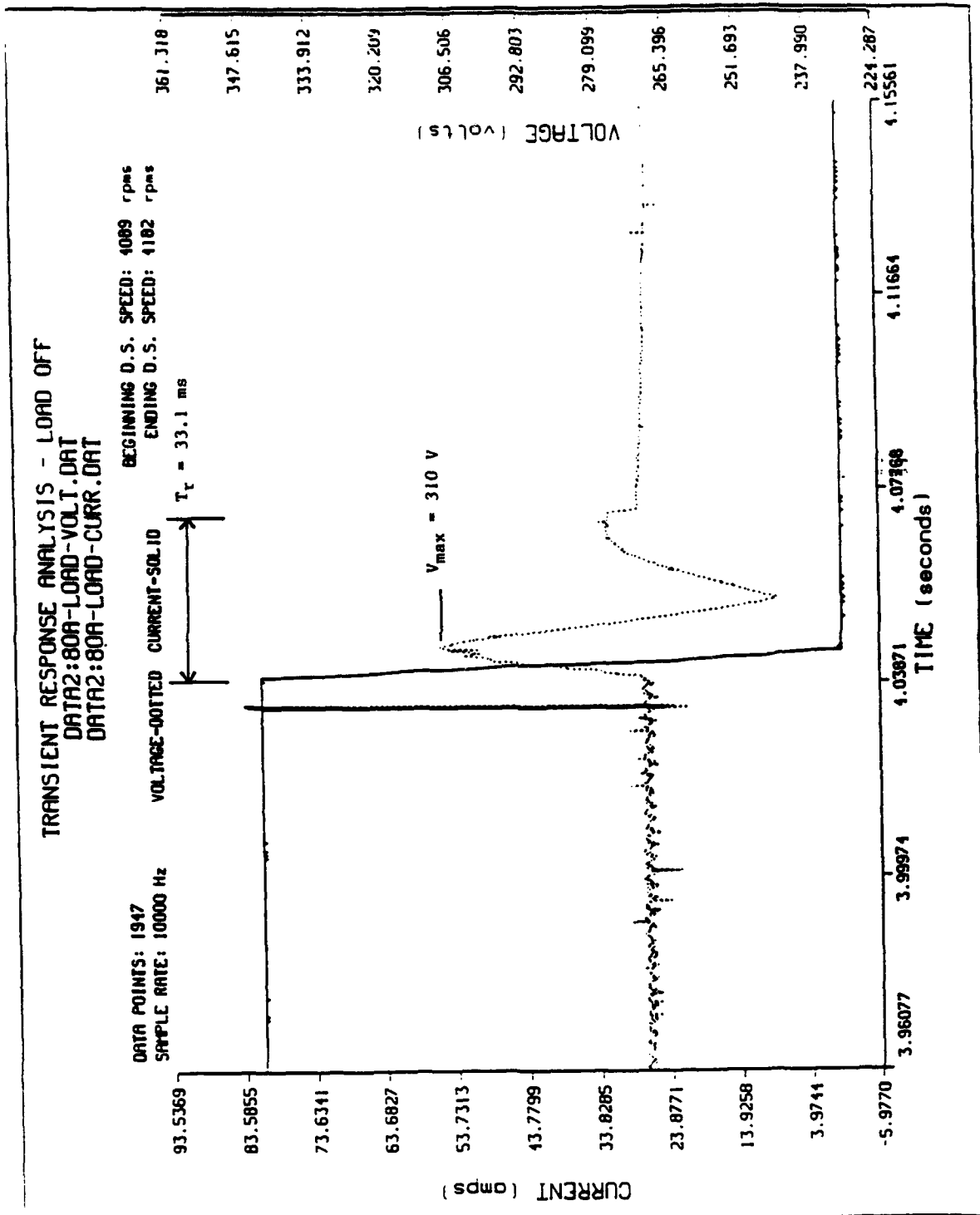

Figure 32: Load Removal Transient; 80 Amps, (4000 rpm)

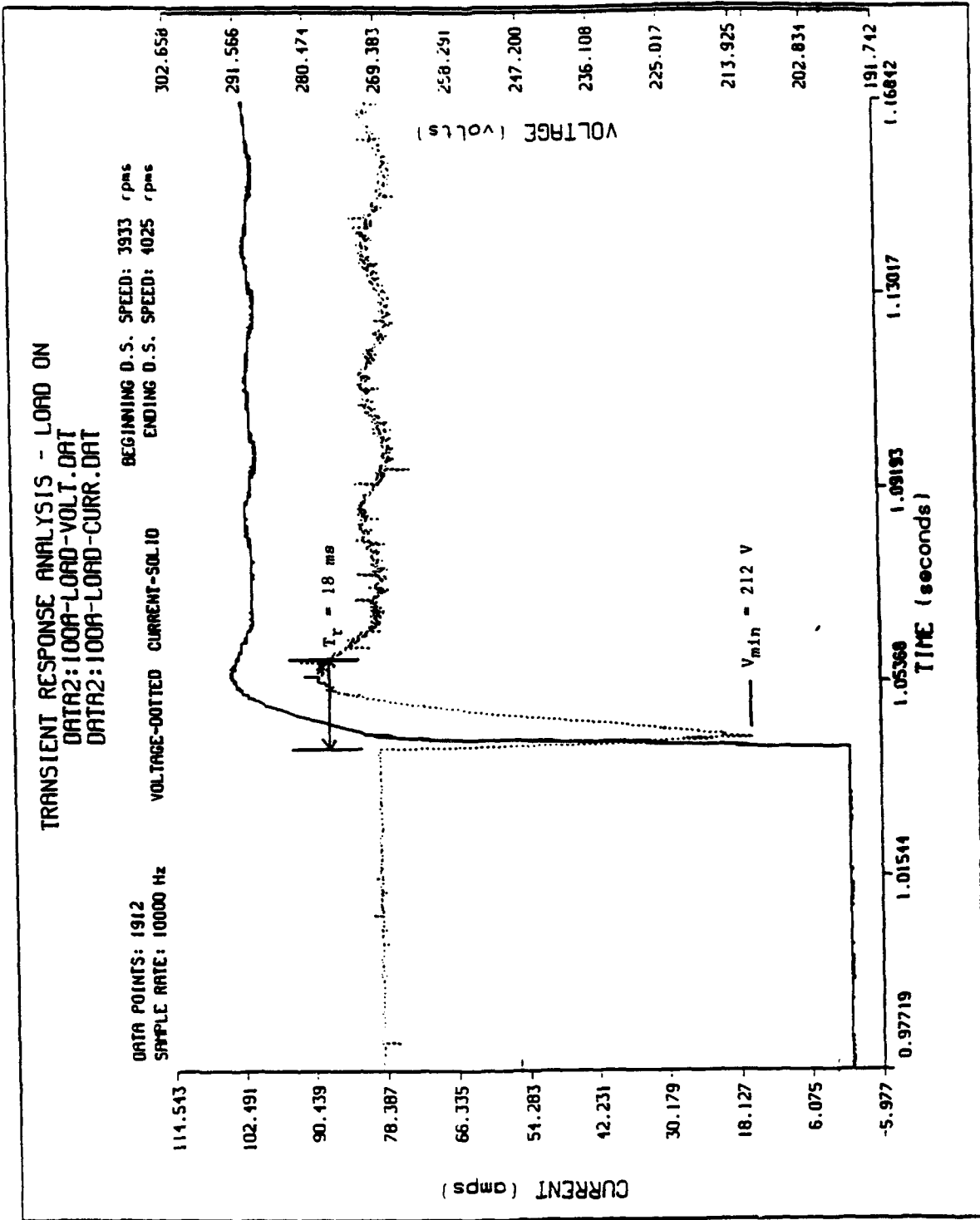

Figure 33: Load Application Transient; 100 Amps, (4000 rpm)

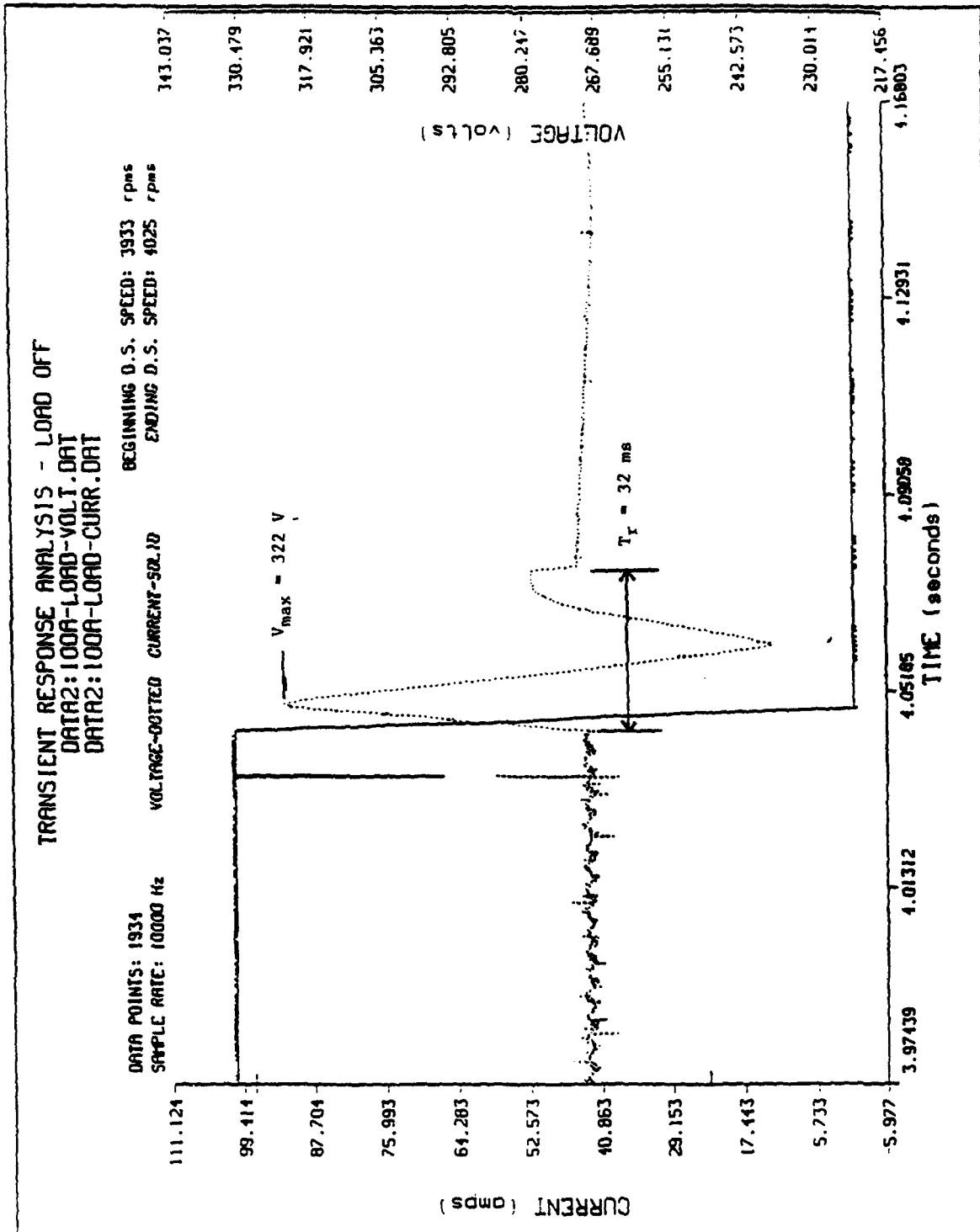

Figure 34: Load Removal Transient; 100 Amps, (4000 rpm)

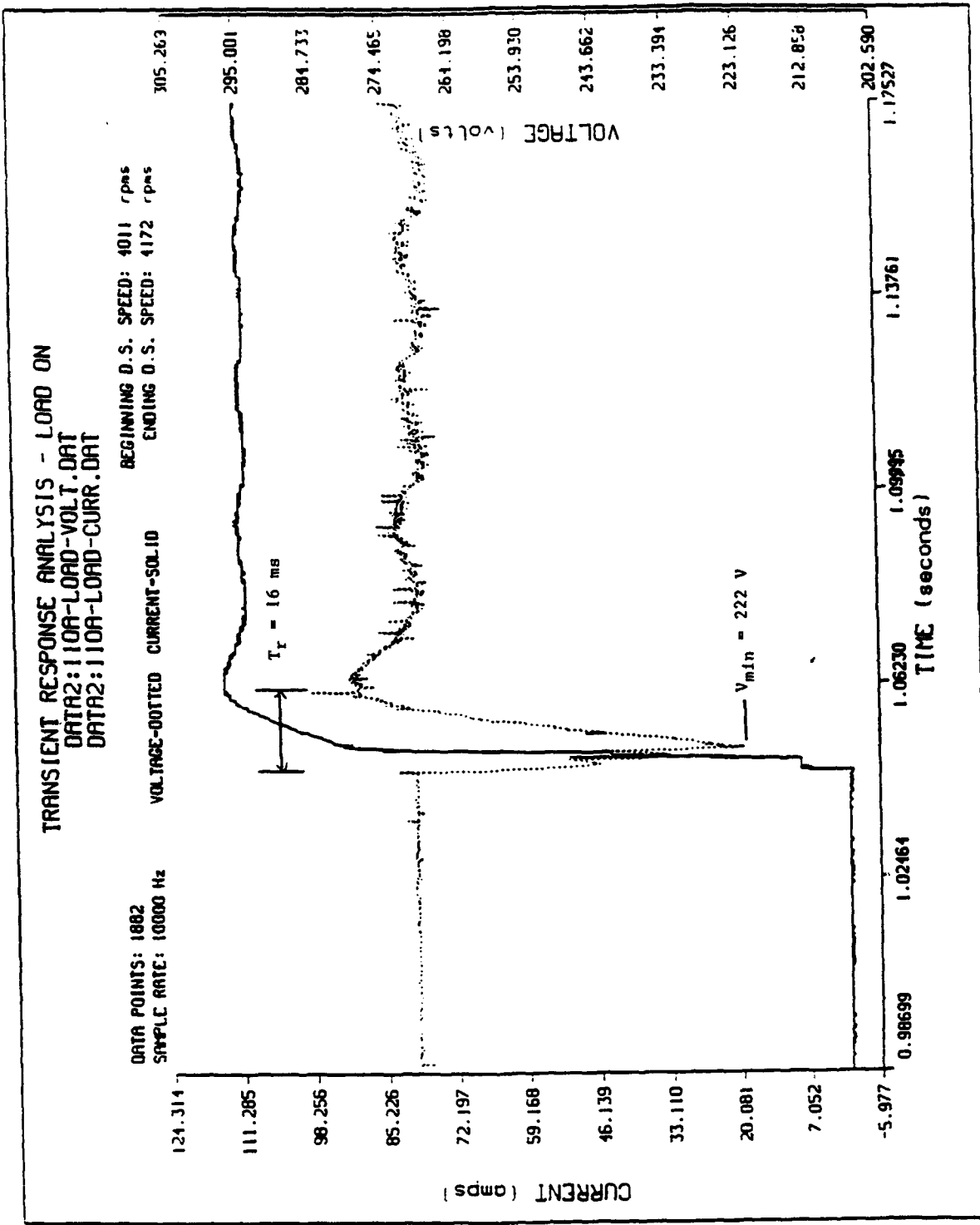

Figure 35: Load Application Transient; 110 Amps, (4000 rpm)

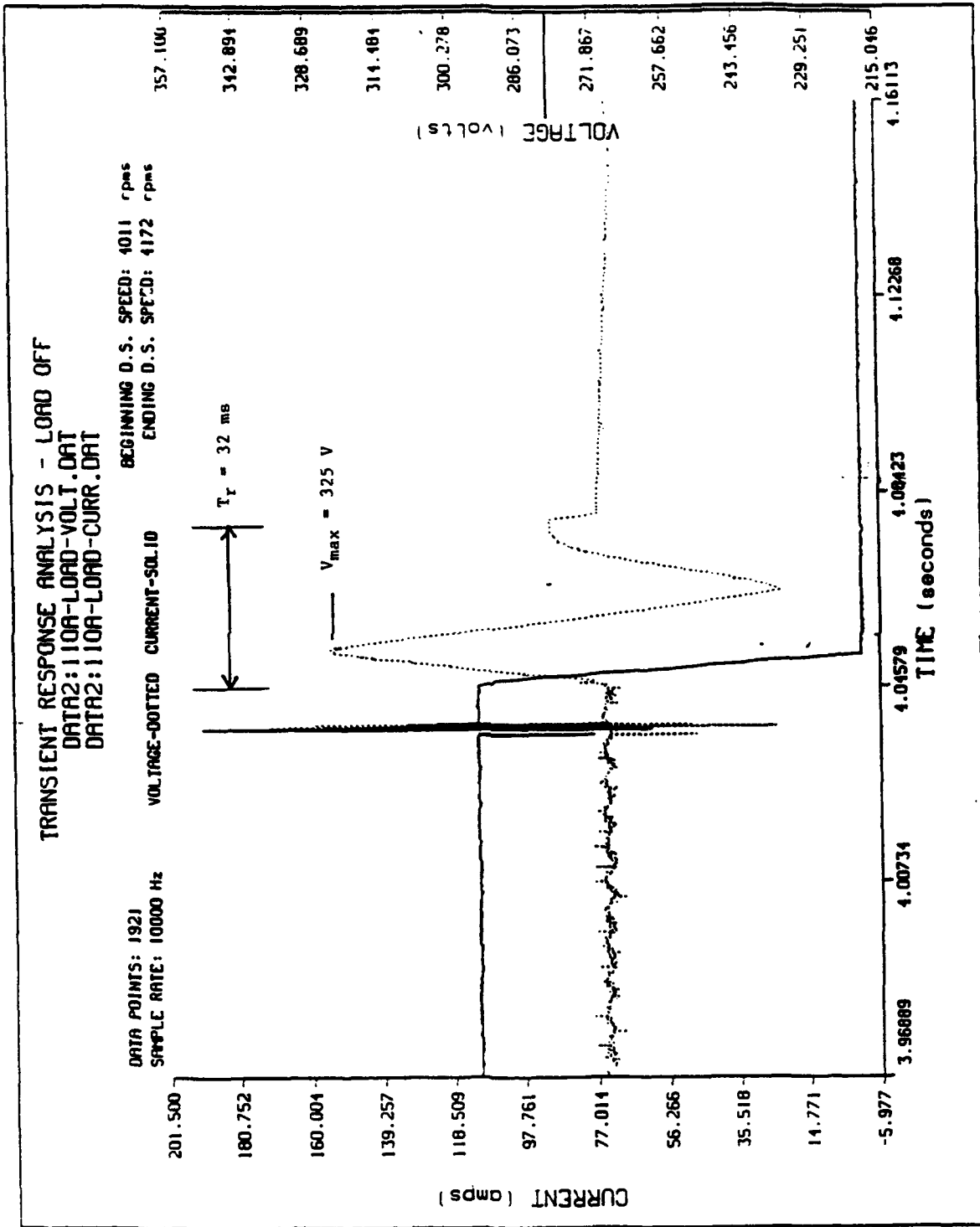

Figure 36: Load Removal Transient; 110 Amps, (4000 rpm)

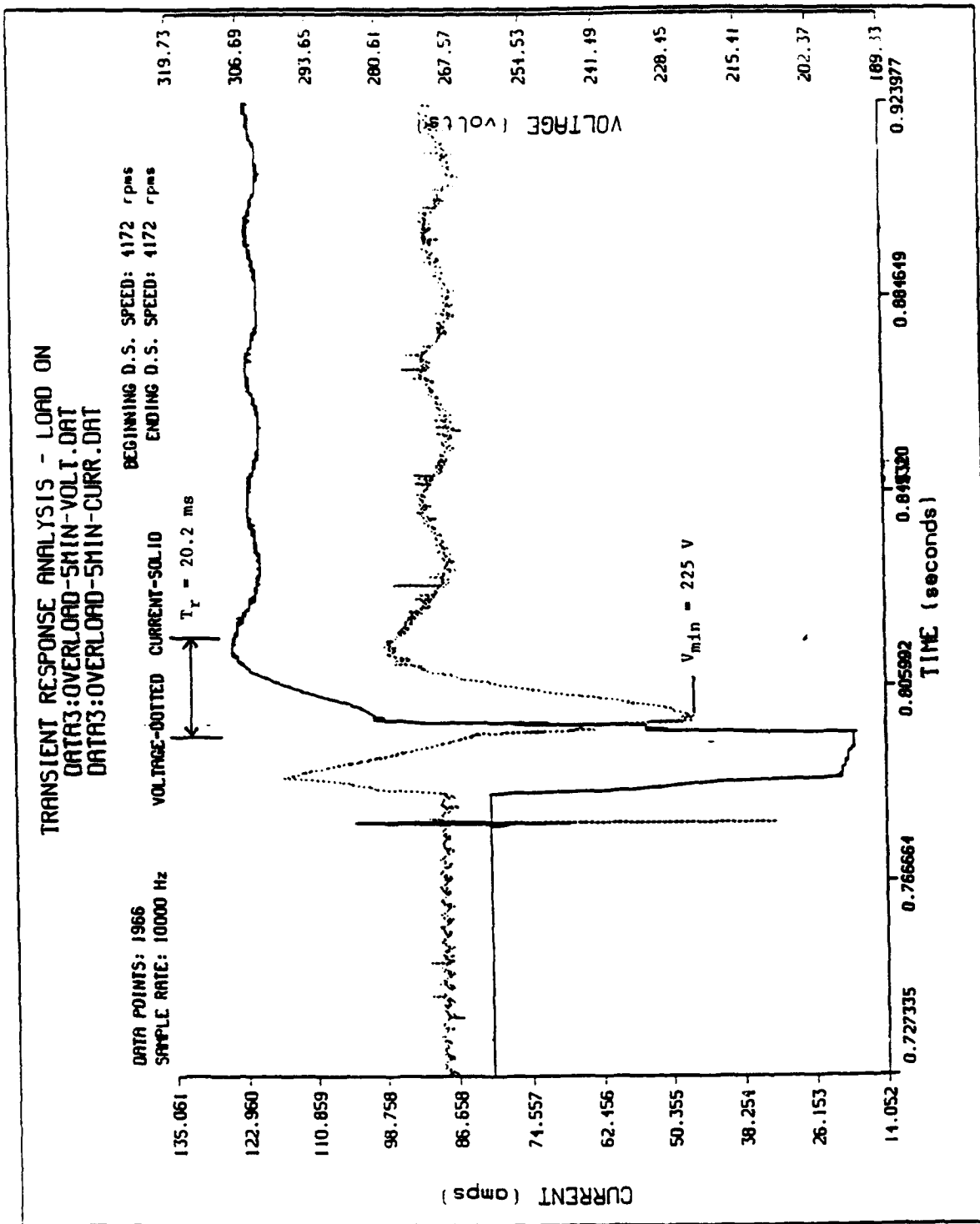

Figure 37: Overload (1.5 pu overload) Application Transient, 120 Amps, (4000 rpm)

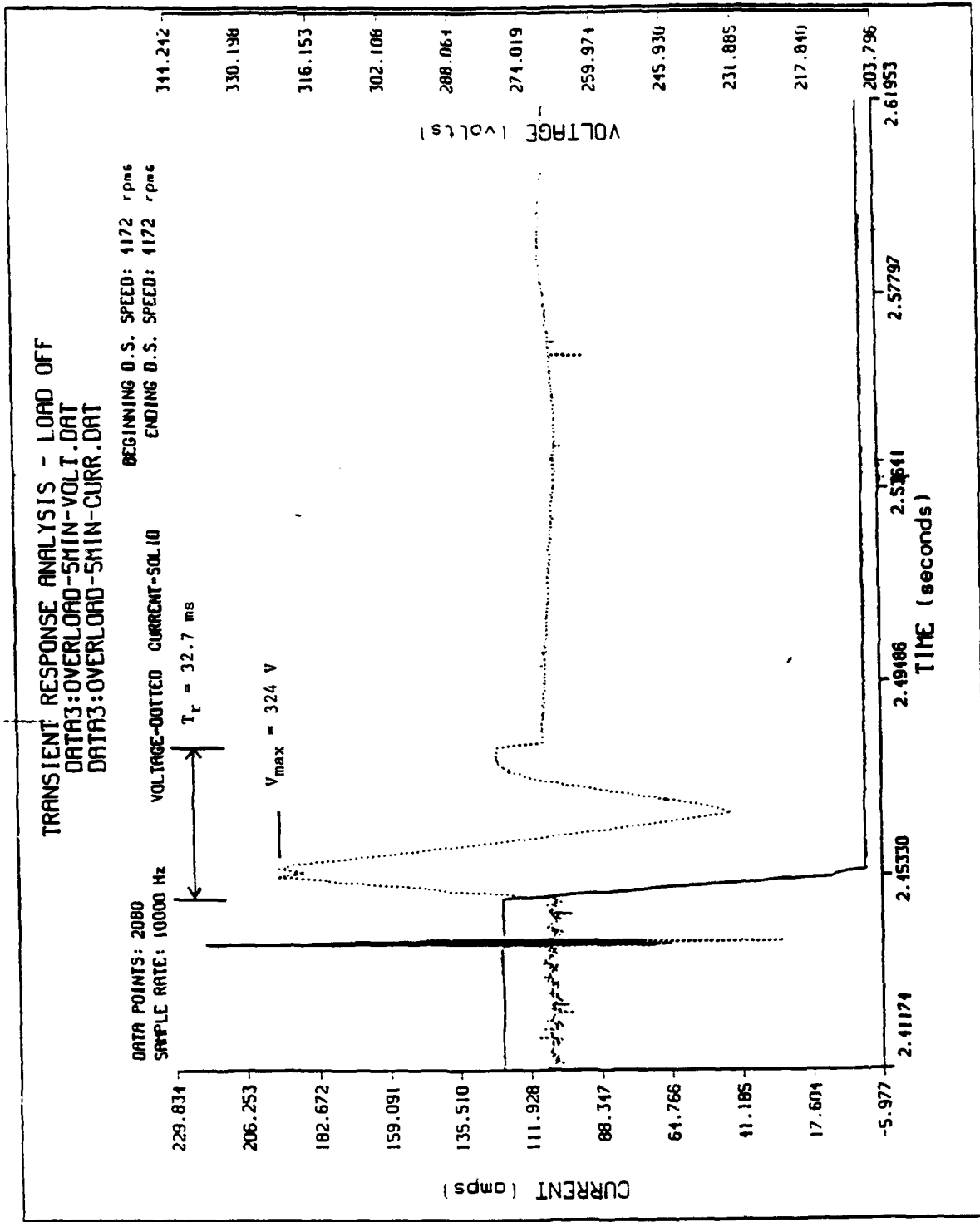

Figure 38: Overload (1.5 pu overload) Removal Transient, 120 Amps, (4000 rpm)

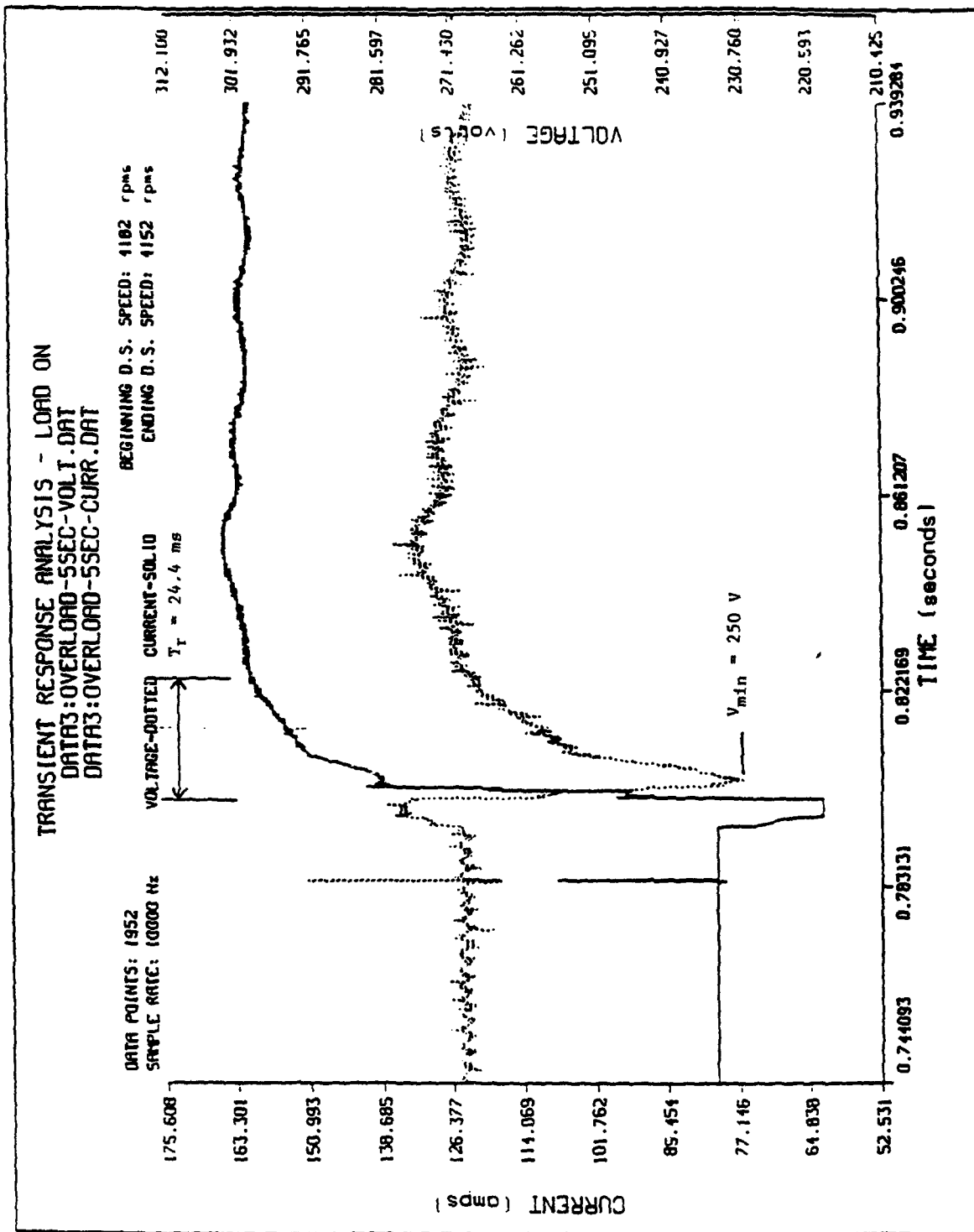

Figure 39: Overload (2.0 pu overload) Application Transient, 160 Amps, (4000 rpm)

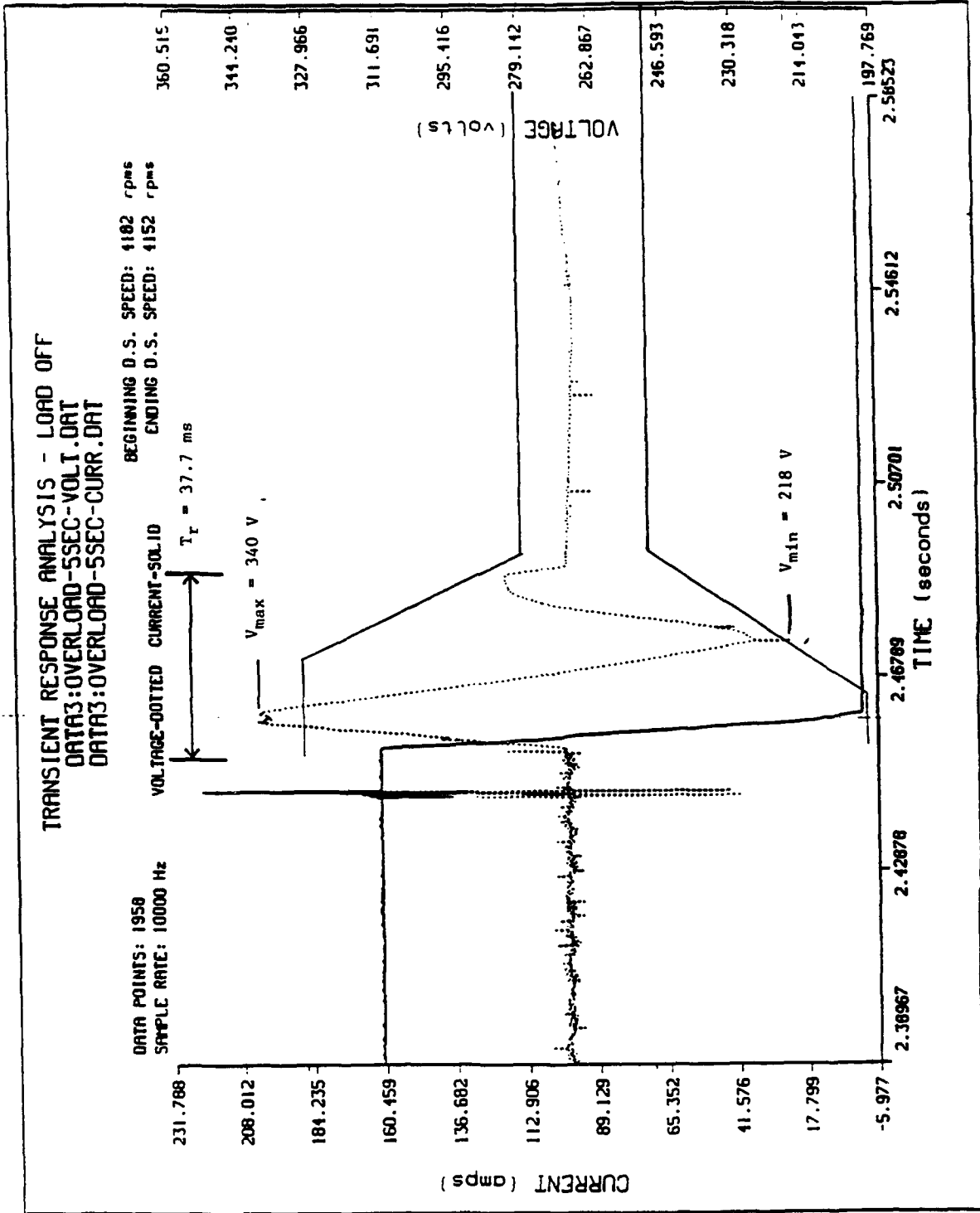

Figure 40: Overload (2.0 pu overload) Removal Transient, 160 Amps, (4000 rpm)

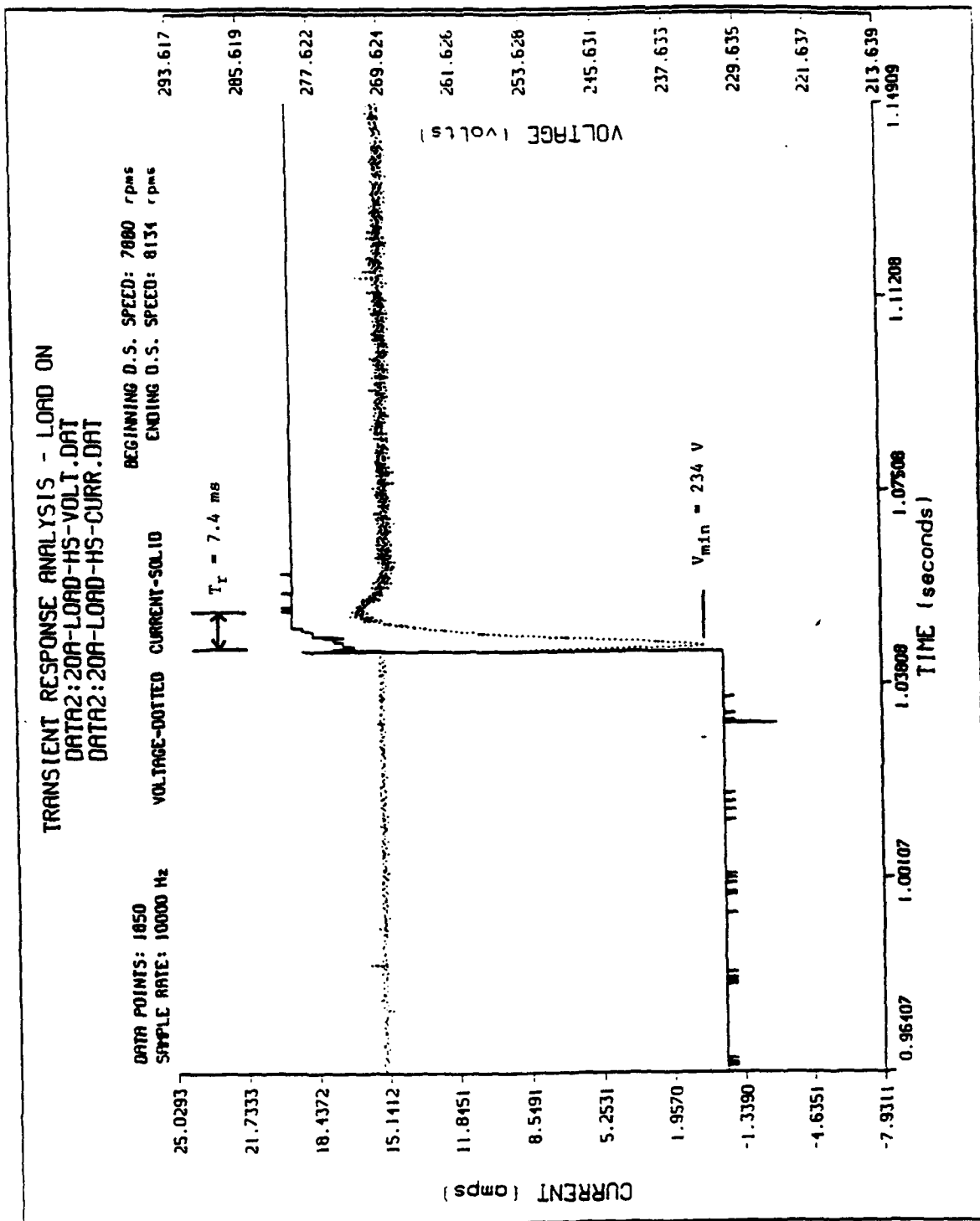

Figure 41: Load Application Transient, 20 Amps, (8200 rpm)

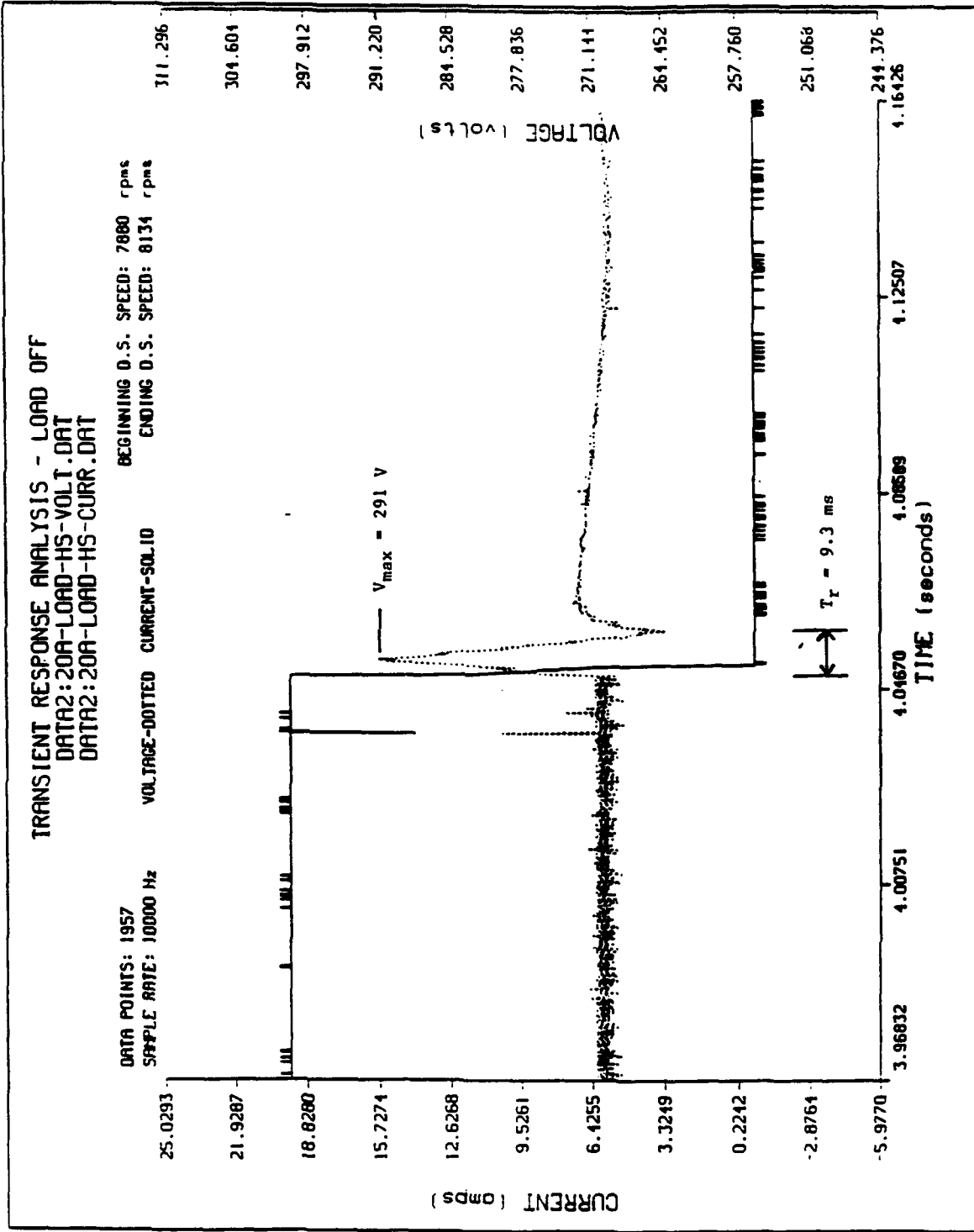

Figure 42: Load Removal Transient, 20 Amps, (8200 rpm)

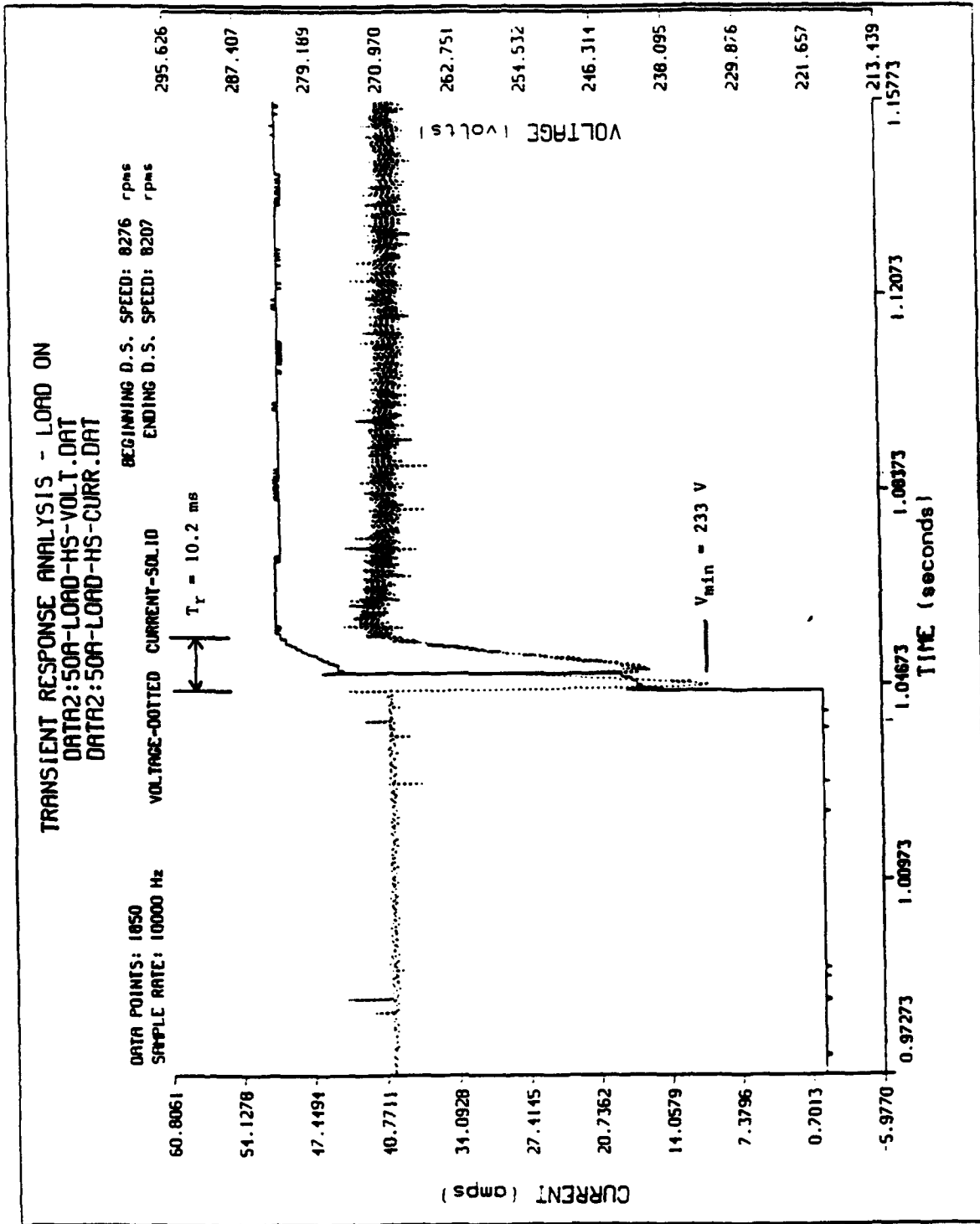

Figure 43: Load Application Transient, 50 Amps, (8200 rpm)

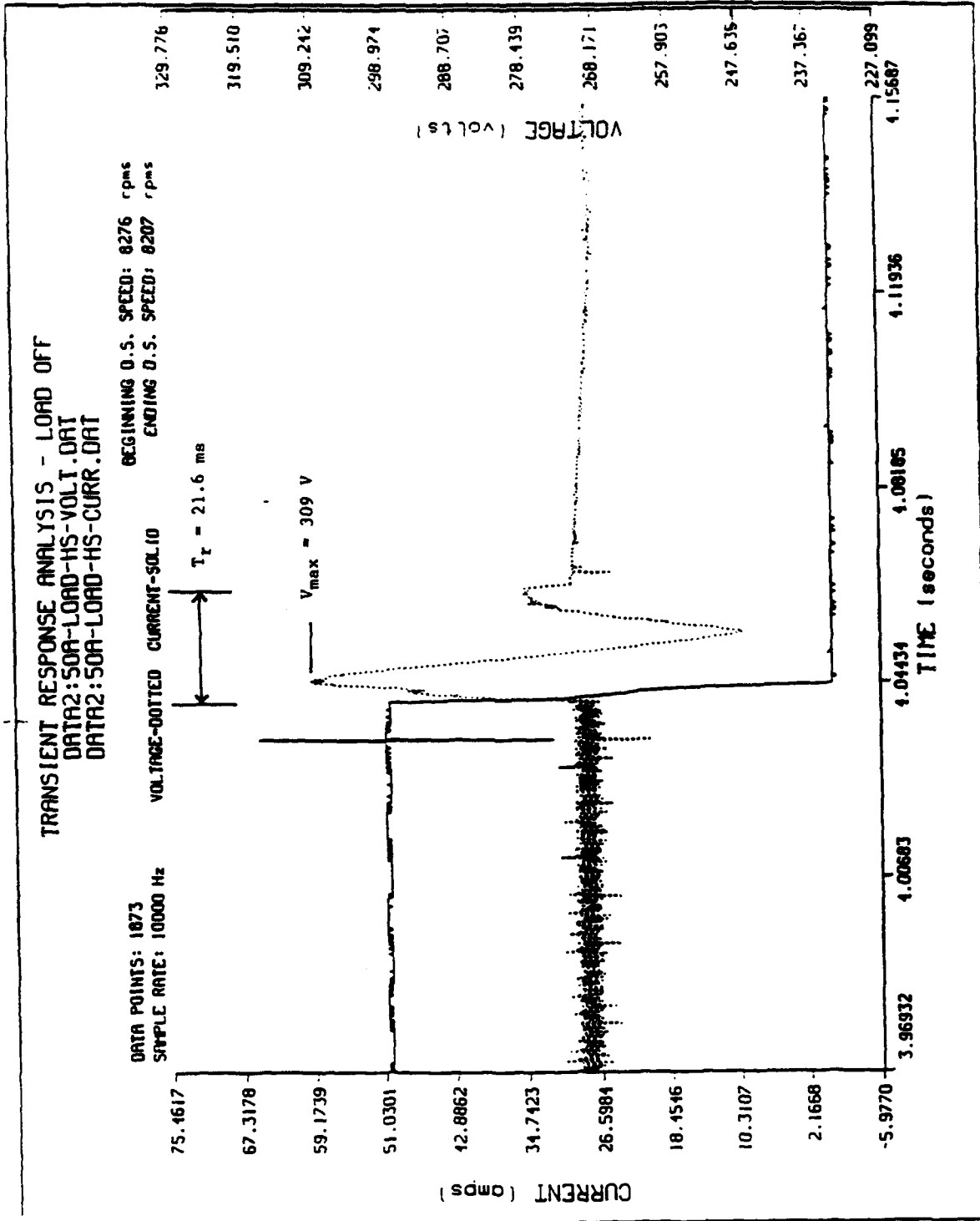

Figure 44: Load Removal Transient, 50 Amps, (8200 rpm)

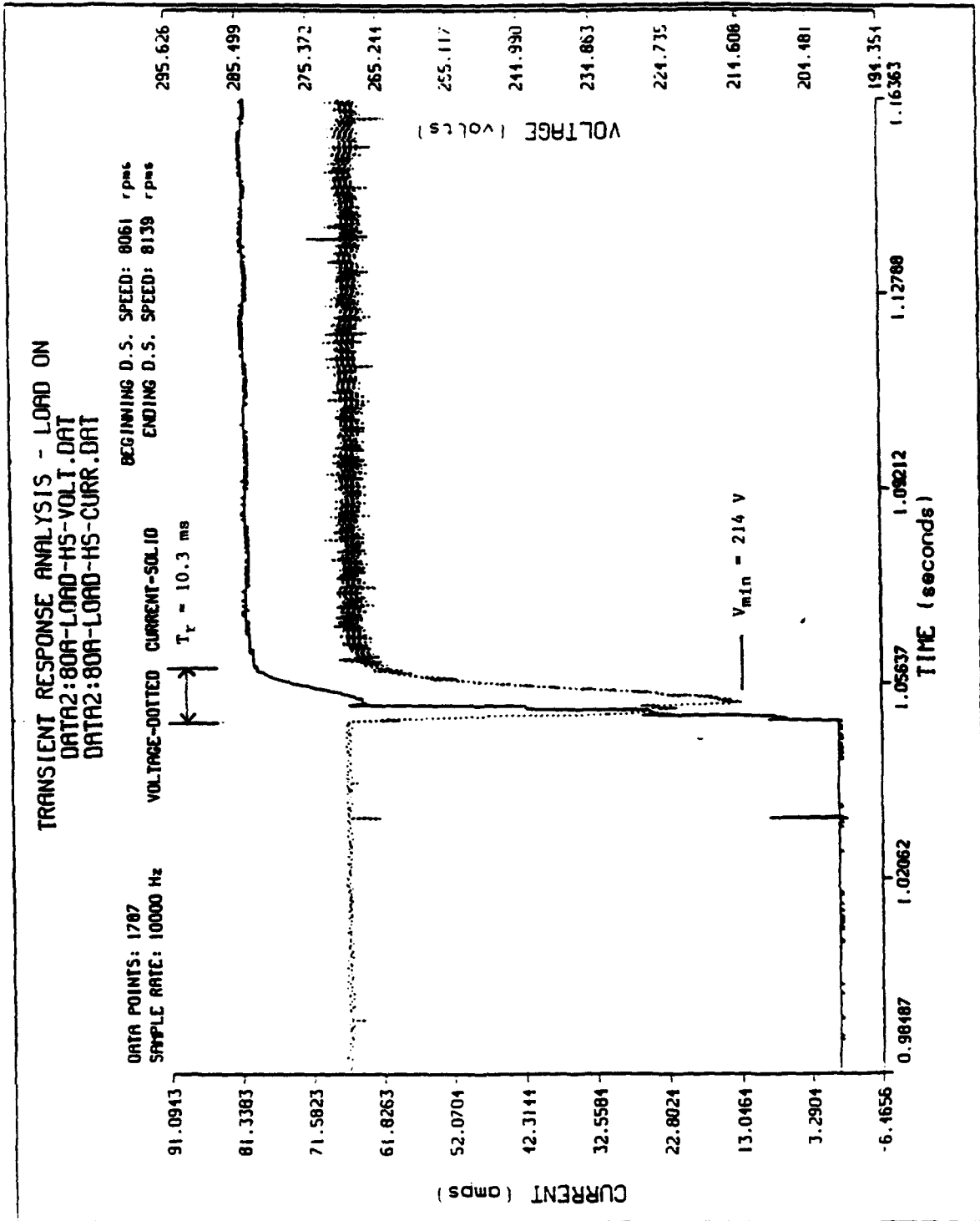

Figure 45: Load Application Transient, 80 Amps, (8200 rpm)

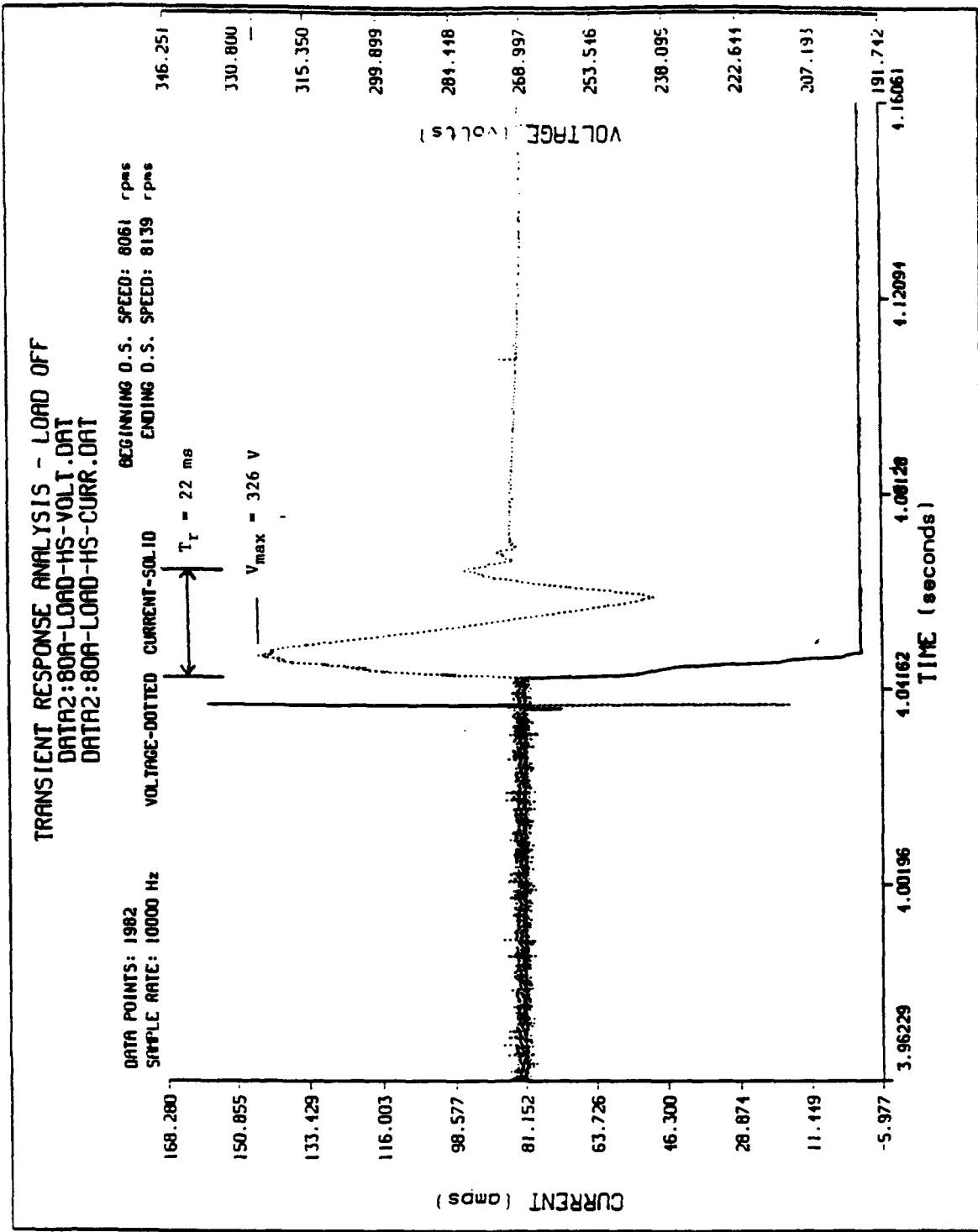

Figure 46: Load Removal Transient, 80 Amps, (8200 rpm)

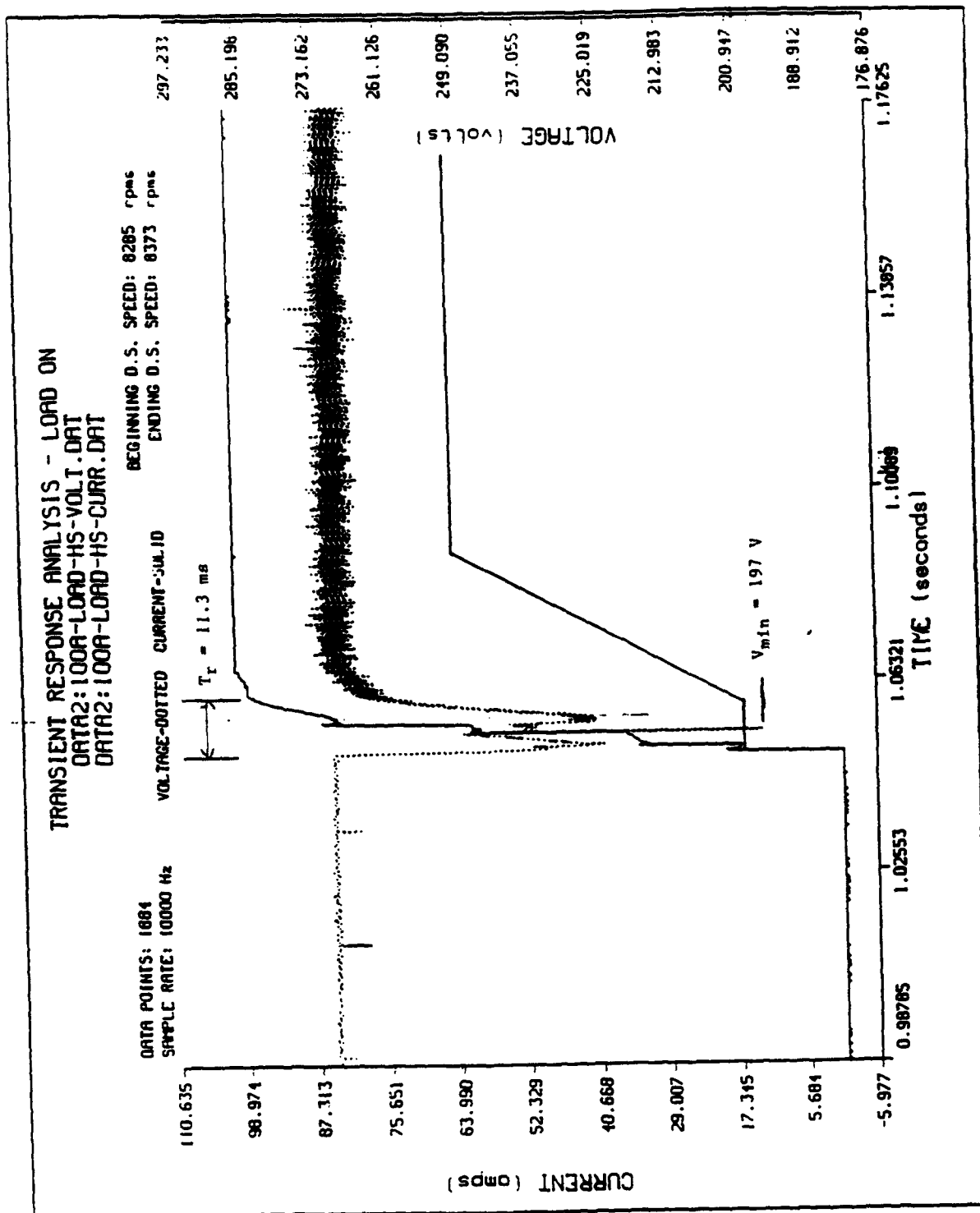

Figure 47: Load Application Transient, 100 Amps, (8200 rpm)

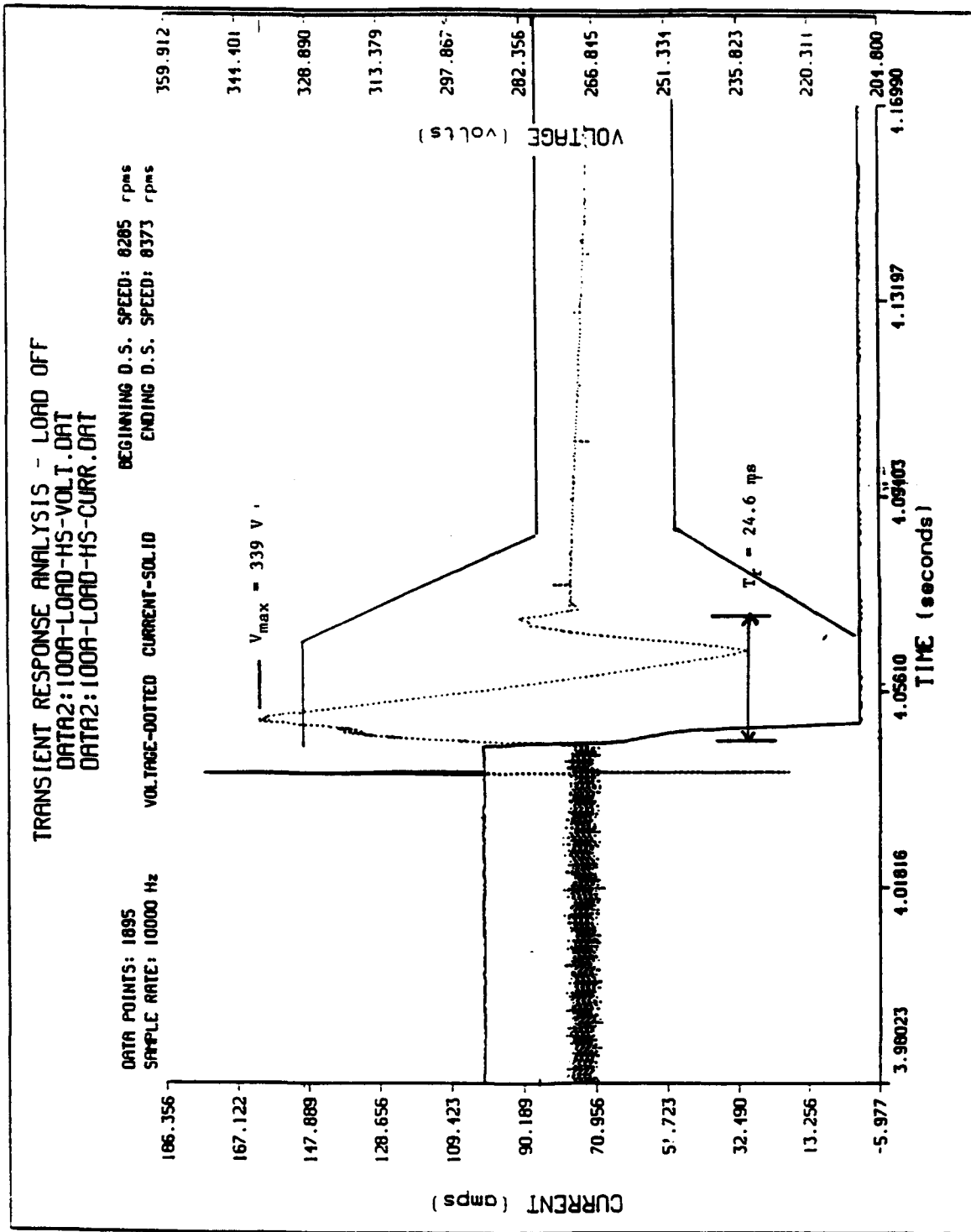

Figure 48: Load Removal Transient, 100 Amps, (8200 rpm)

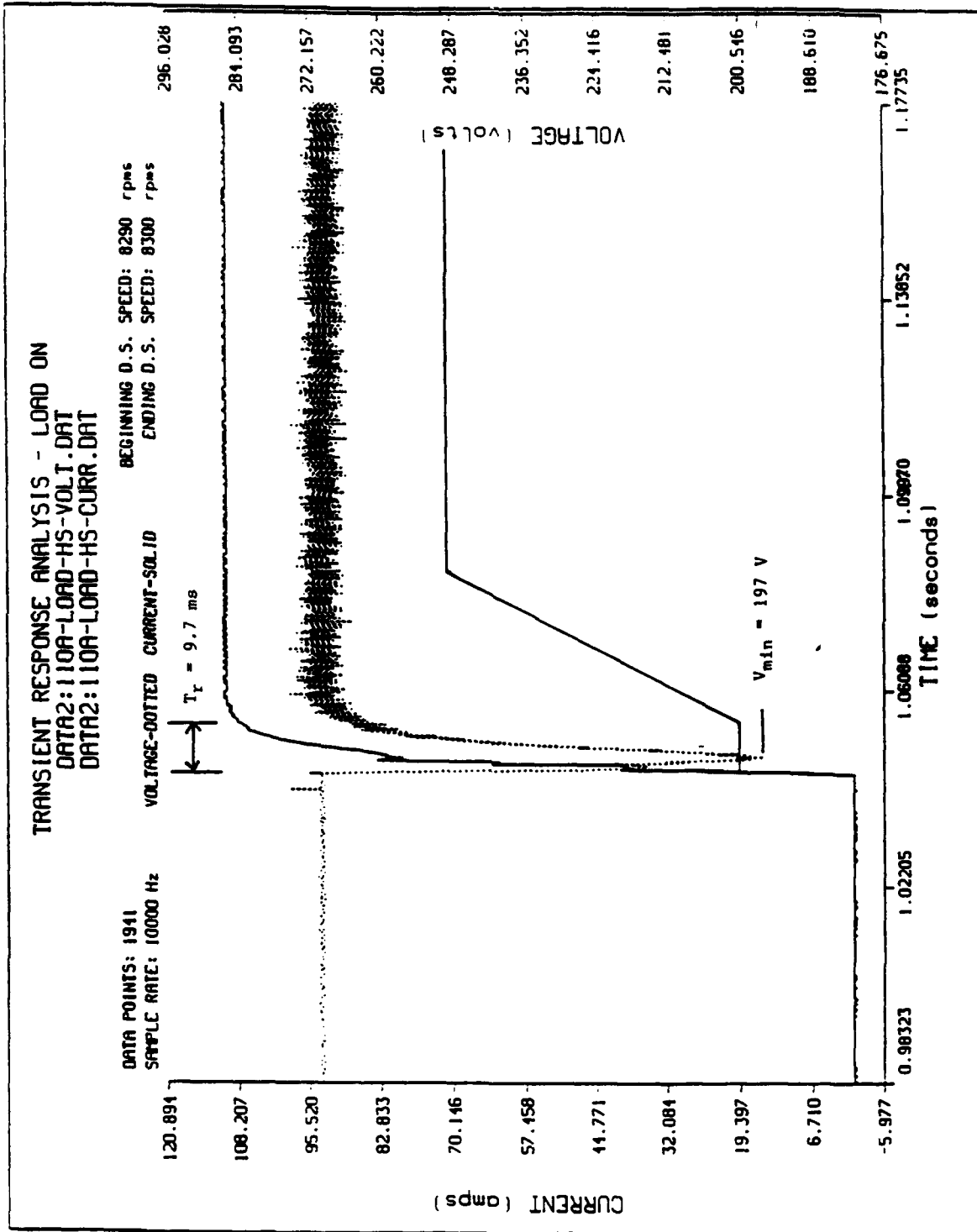

Figure 49: Load Application Transient, 110 Amps, (8200 rpm)

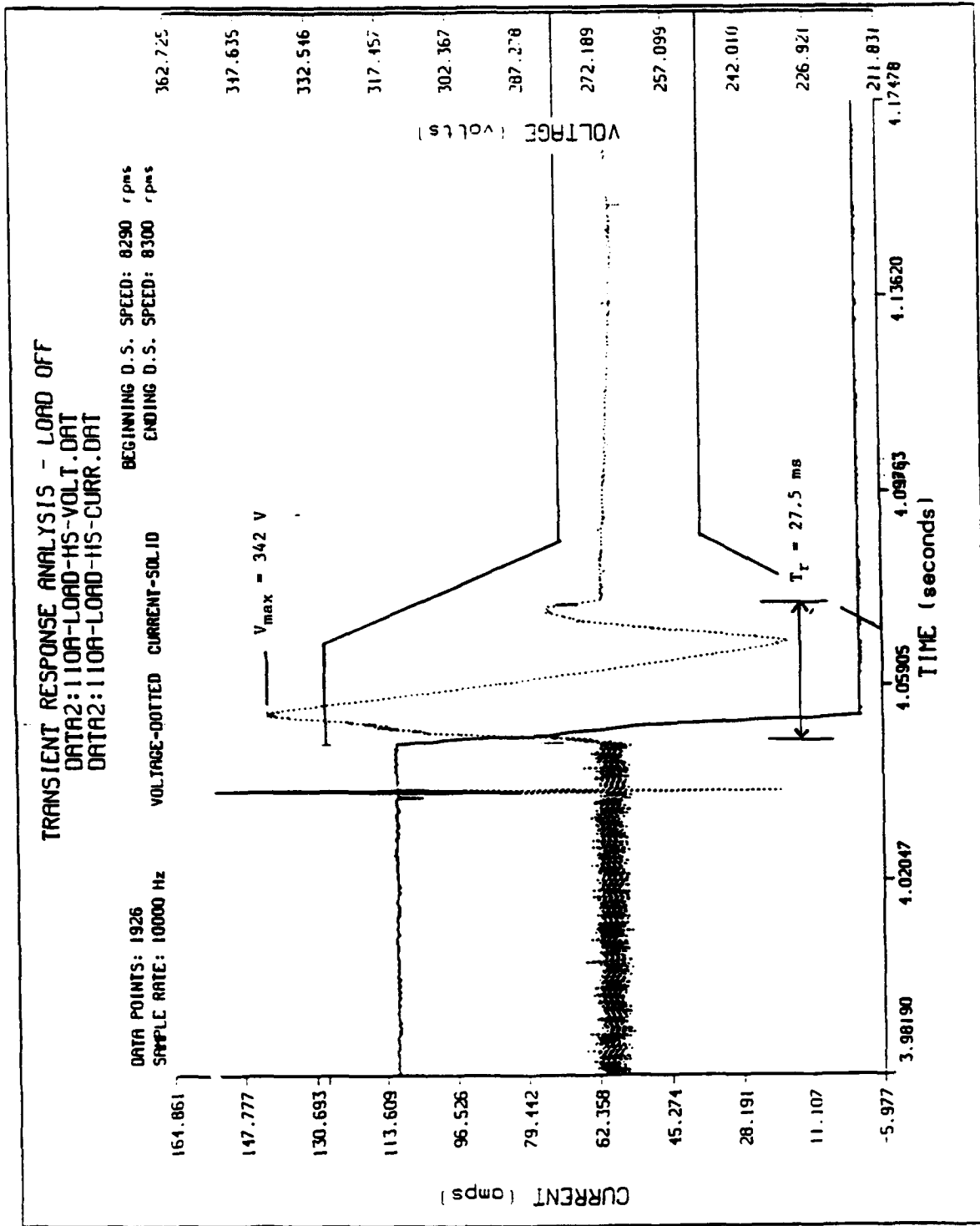

Figure 50: Load Removal Transient, 110 Amps, (8200 rpm)

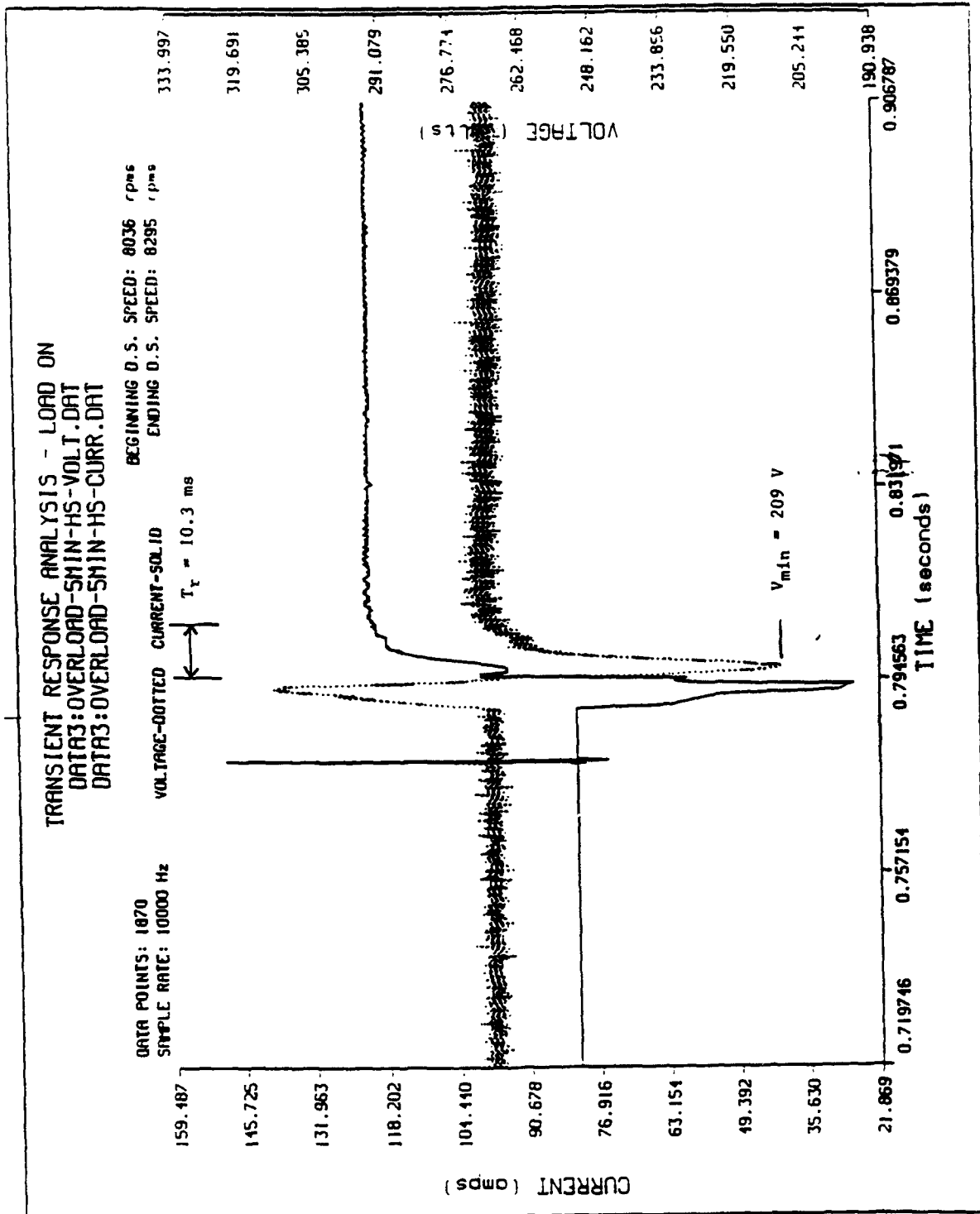

Figure 51: Overload (1.5 pu overload) Application Transient, 120 Amps, (8200 rpm)

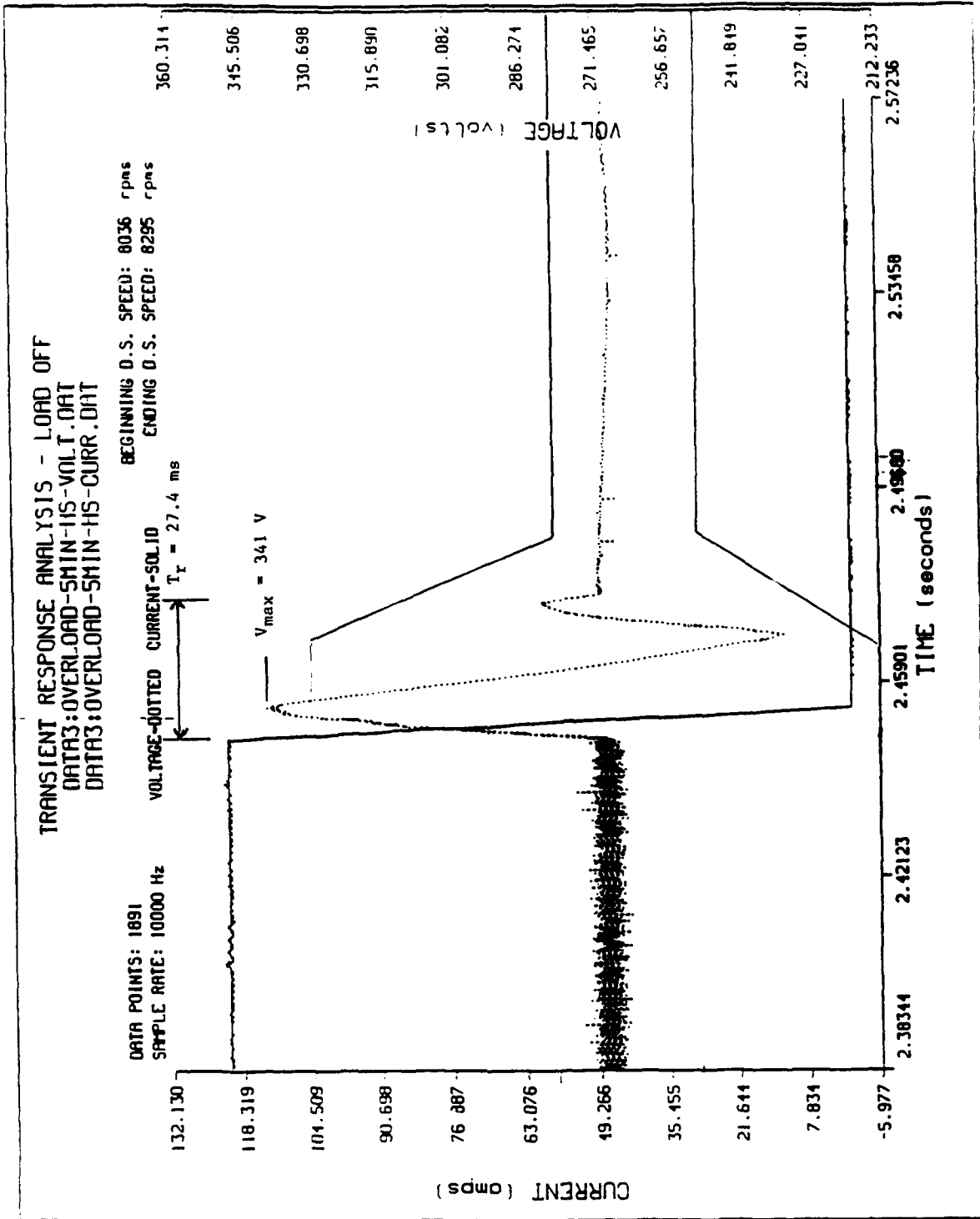

Figure 52: Overload (1.5 pu overload) Removal Transient, 120 Amps, (8200 rpm)

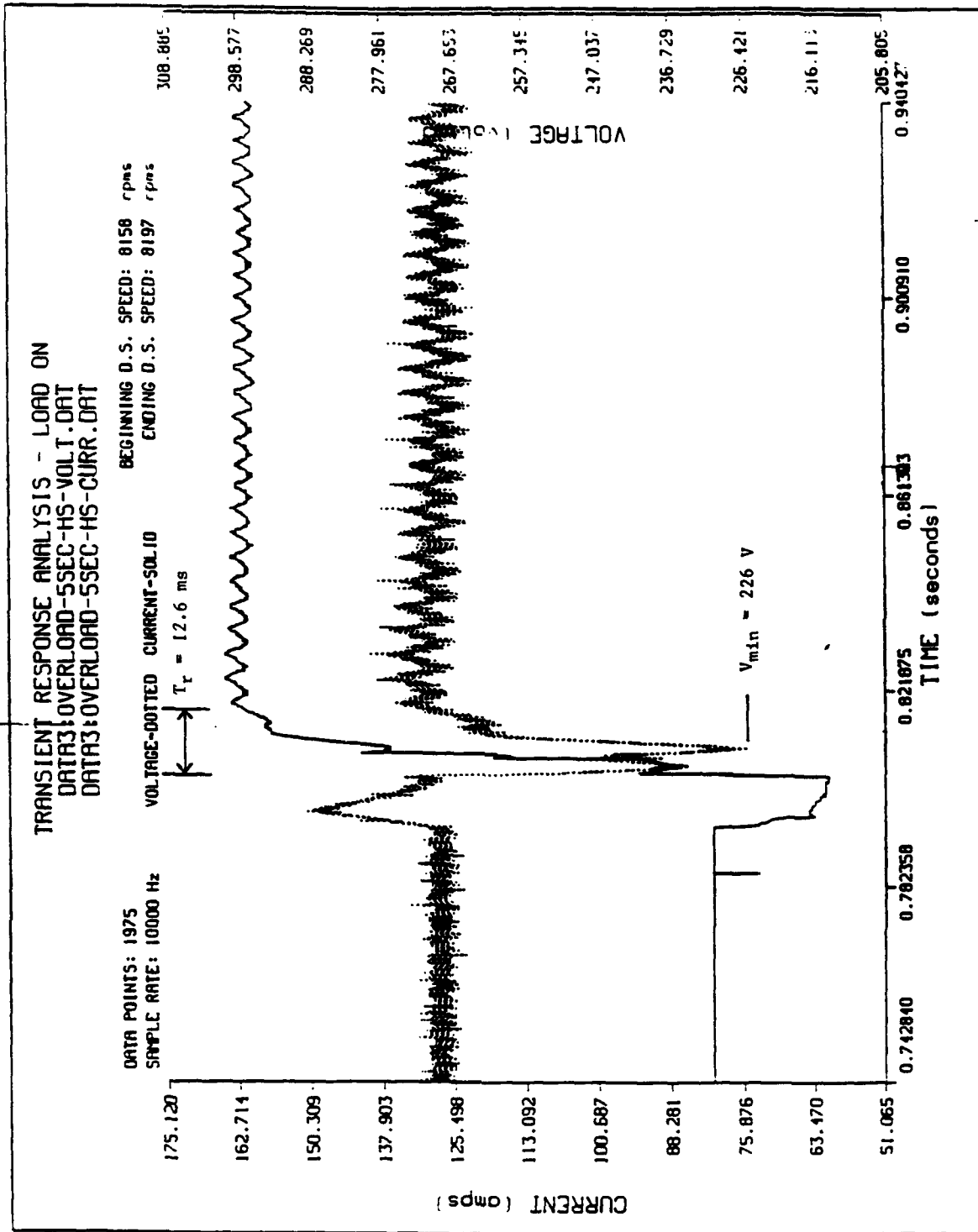

Figure 53: Overload (2.0 pu overload) Application Transient, 160 Amps, (8200 rpm)

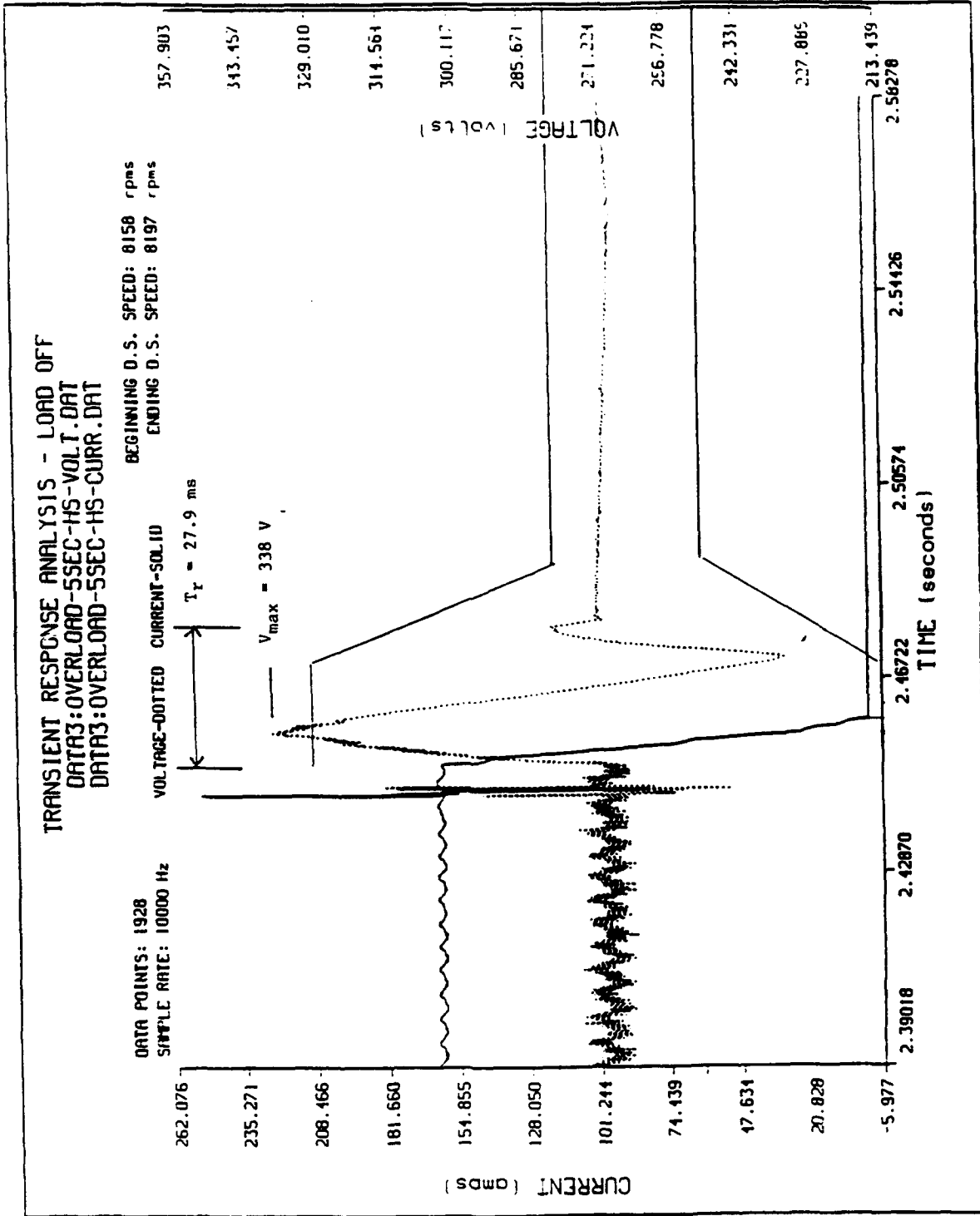

Figure 54: Overload (2.0 pu overload) Removal Transient, 160 Amps, (8200 rpm)

RIPPLE CHARACTERISTICS

Peak-to-peak ripple voltage was measured at no load, 20 A, 50 A, 80 A, 100 A, and 110 A with generator speeds of 4000 rpm and 8200 rpm. A Fast Fourier Transform (FFT) was then performed on this data to obtain distortion characteristics. The ripple measurements are tabulated in Table 3. A plot of Table 3 data can be found in Figure 55. Table 3 data was obtained from Figures 56 - 67. All measured ripple voltages were well below the MIL-STD-704E limit of 6 Volts. The results indicate that at 4000 rpm, the amount of load does not significantly affect the ripple voltage. The average ripple voltage at 4000 rpm (excluding no load) is 1.51 V_{pp} . Generator speed affects the ripple voltage in that at 8200 rpm the ripple voltage (excluding no load) is small compared to the 4000 rpm values for loads of 80 A and less. At 8200 rpm, increasing loads result in higher ripple voltages with ripple beginning to increase exponentially for loads greater than 80 A. Note that minimum ripple for the 4000 rpm loads occurred at 80 A (see Figure 55).

Table 3: Peak-to-Peak Ripple Voltage

Load (Amps)	Ripple Voltage (V_{pp})	
	Generator Speed = 4000 rpm	Generator Speed = 8200 rpm
0	0.164	0.113
20	1.65	0.385
50	1.42	0.400
80	1.12	0.582
100	1.67	2.19
110	1.68	3.18

Figure 55: Peak-to-Peak Ripple Voltage (Excluding No-Load)

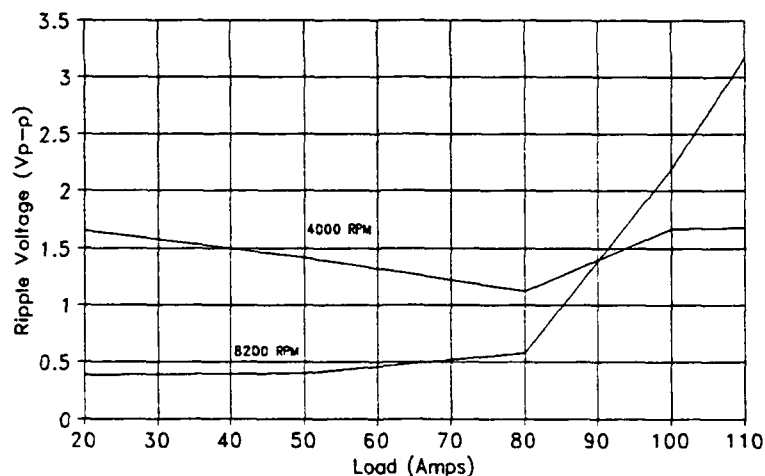

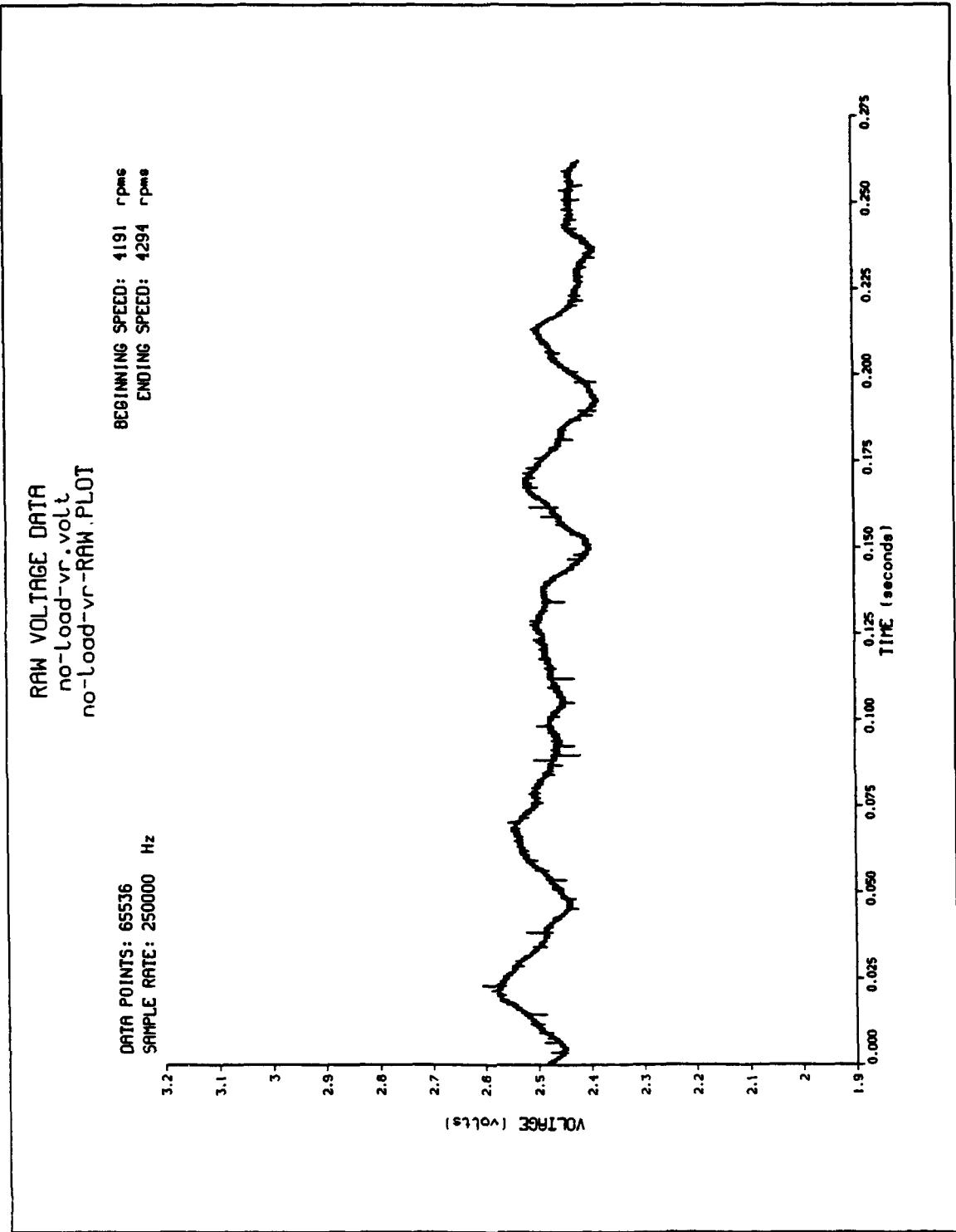

Figure 56: No Load Ripple Voltage, 4000 rpm

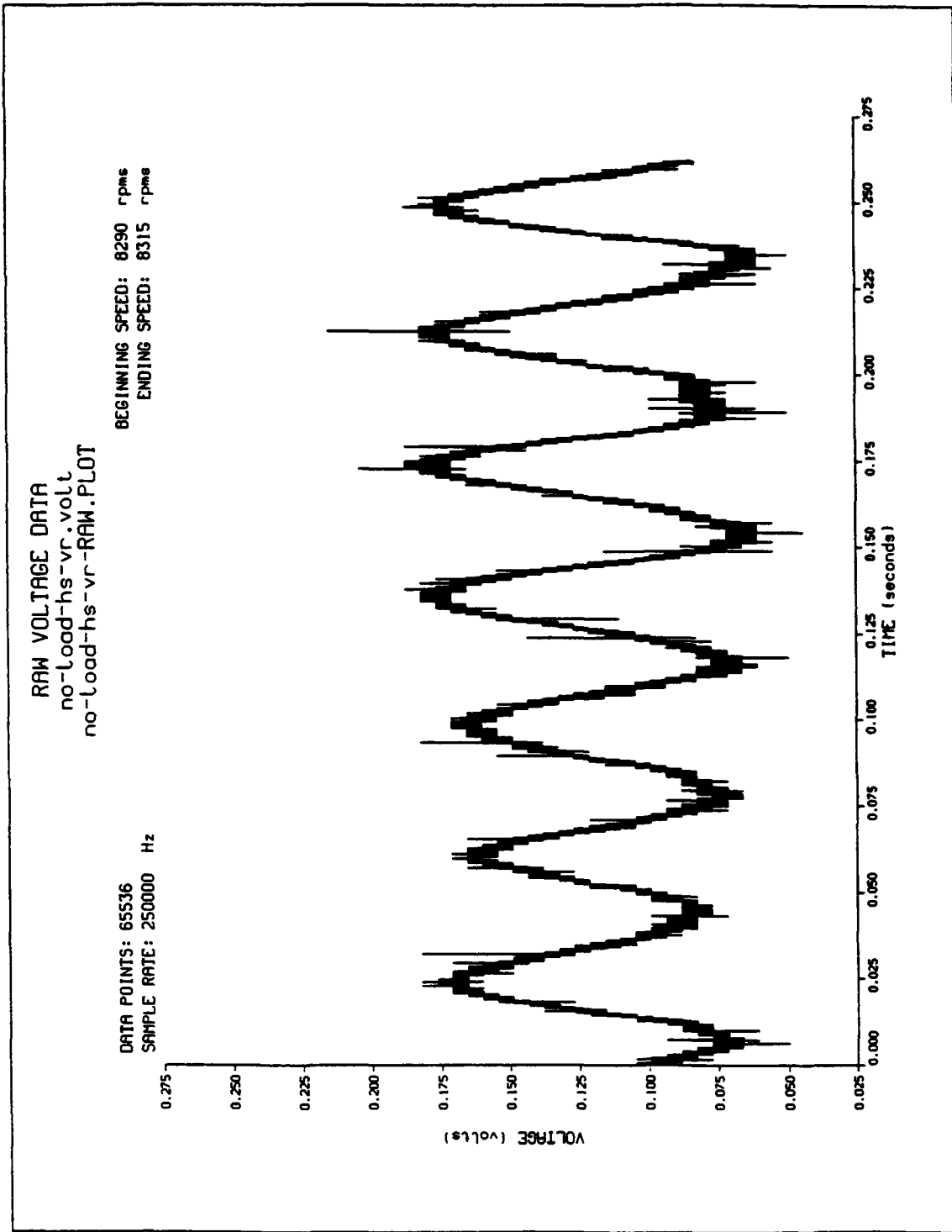

Figure 57: No Load Ripple Voltage, 8200 rpm

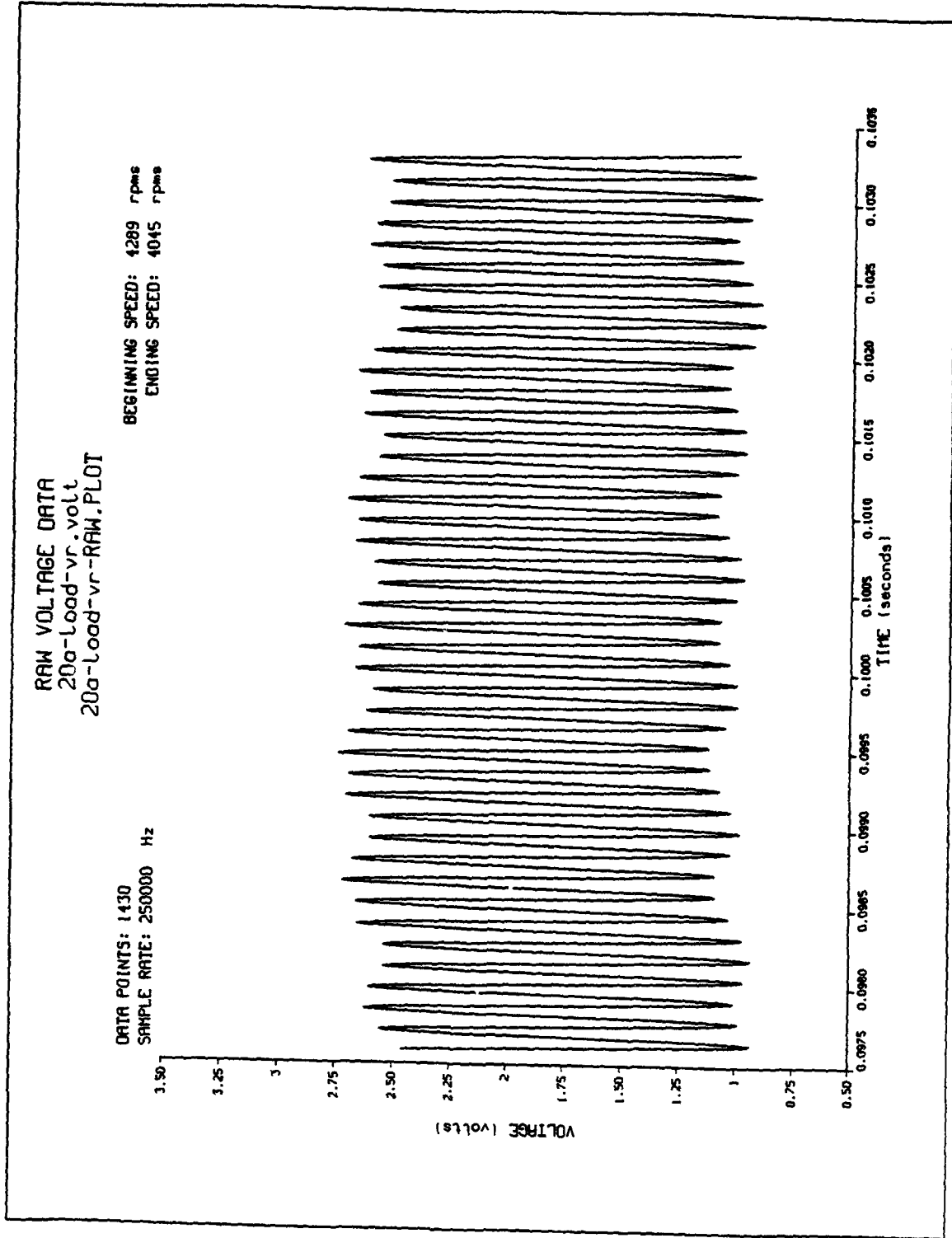

Figure 58: Ripple Voltage, 20 Amp Load, 4000 rpm

RAW VOLTAGE DATA
20a-Load-hs-vr.volt
20a-Load-hs-vr-RAW.PLOT

BEGINNING SPEED: 8486 rpm
ENDING SPEED: 8432 rpm

DATA POINTS: 1503
SAMPLE RATE: 250000 Hz

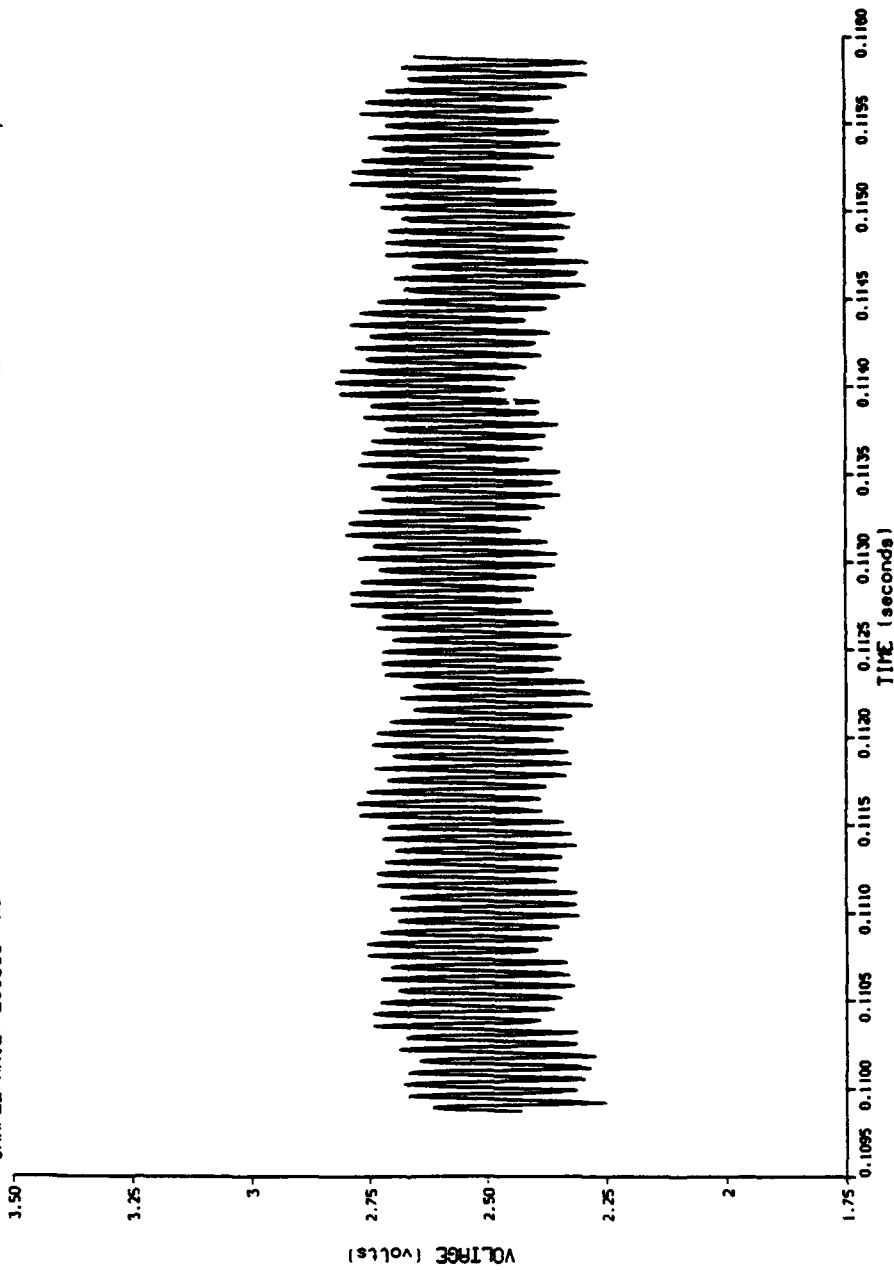

Figure 59: Ripple Voltage, 20 Amp Load, 8200 rpm

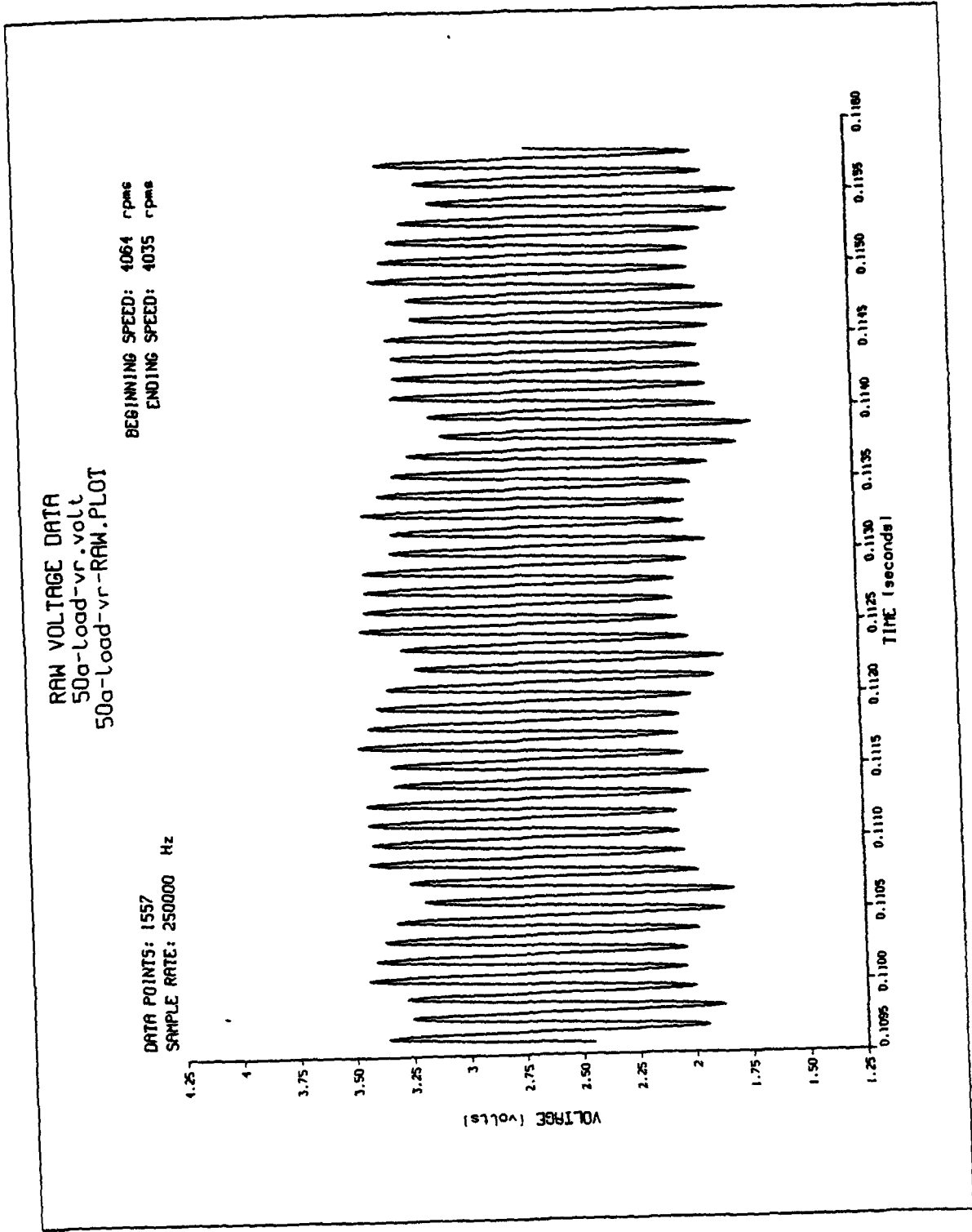

Figure 60: Ripple Voltage, 50 Amp Load, 4000 rpm

RAW VOLTAGE DATA

50a-Load-hs-vr.volt

50a-Load-hs-vr-RAW.PLOT

BEGINNING SPEED: 8447 rpm
ENDING SPEED: 8486 rpm

DATA POINTS: 1971
SAMPLE RATE: 250000 Hz

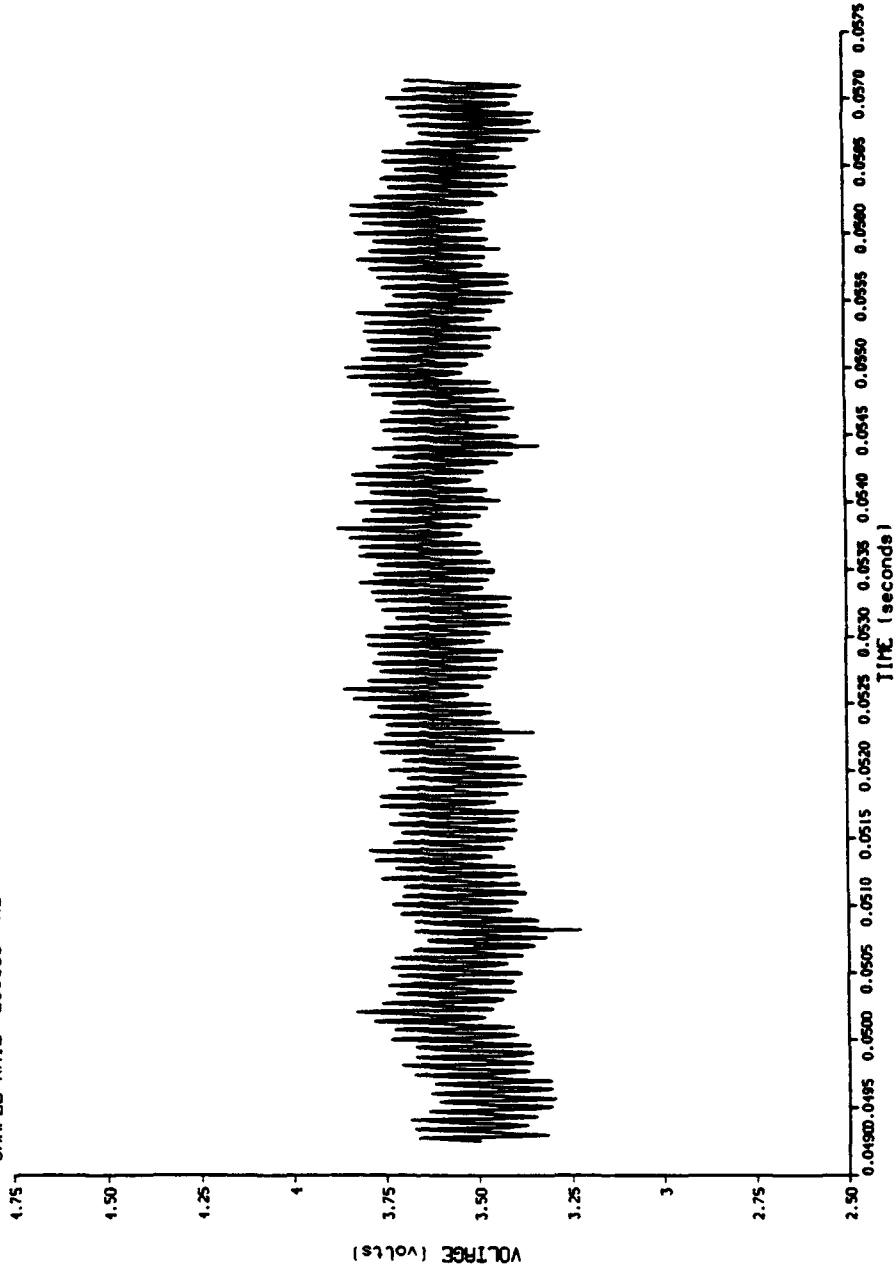

Figure 61: Ripple Voltage, 50 Amp Load, 8200 rpm

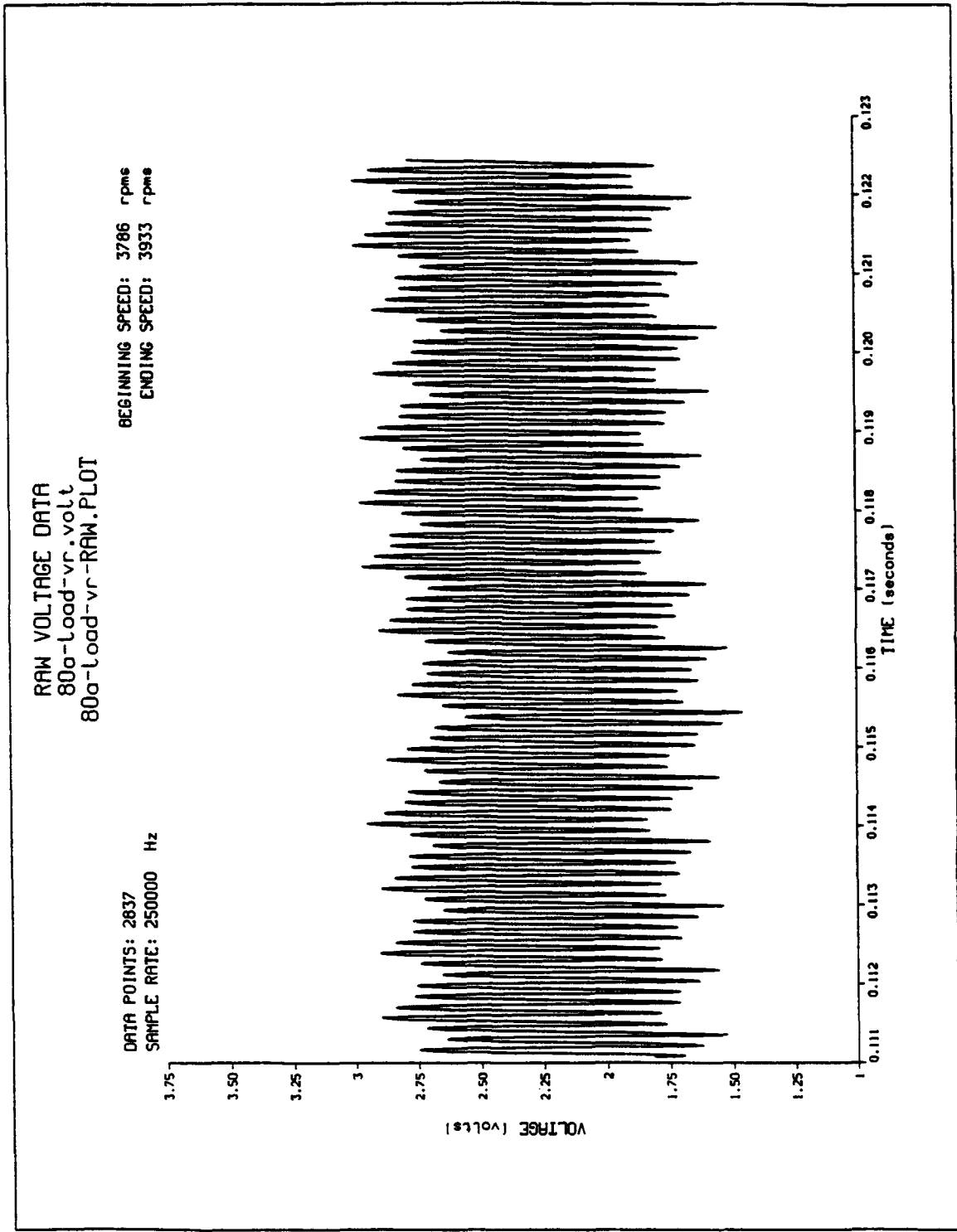

Figure 62: Ripple Voltage, 80 Amp Load, 4000 rpm

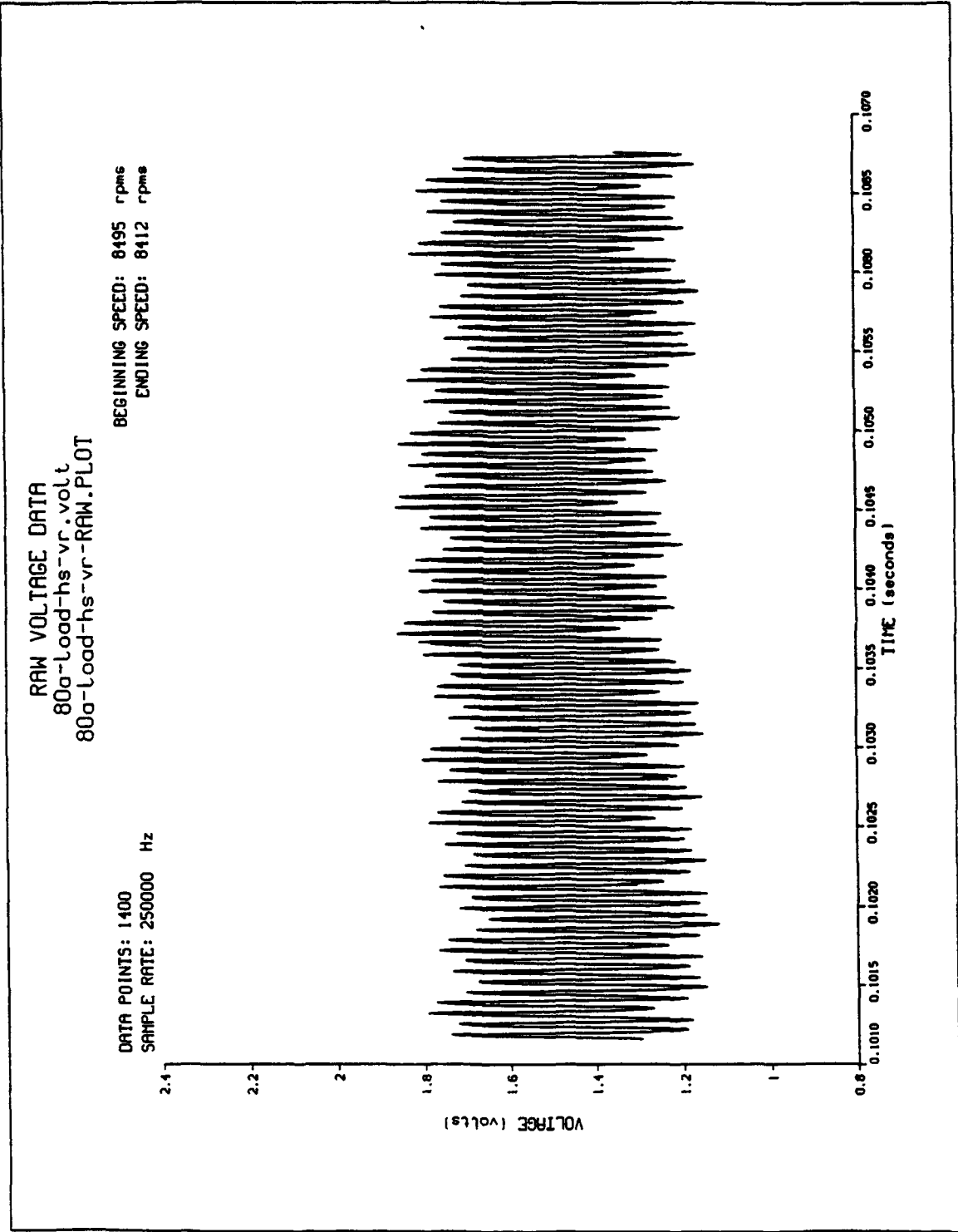

Figure 63: Ripple Voltage, 80 Amp Load, 8200 rpm

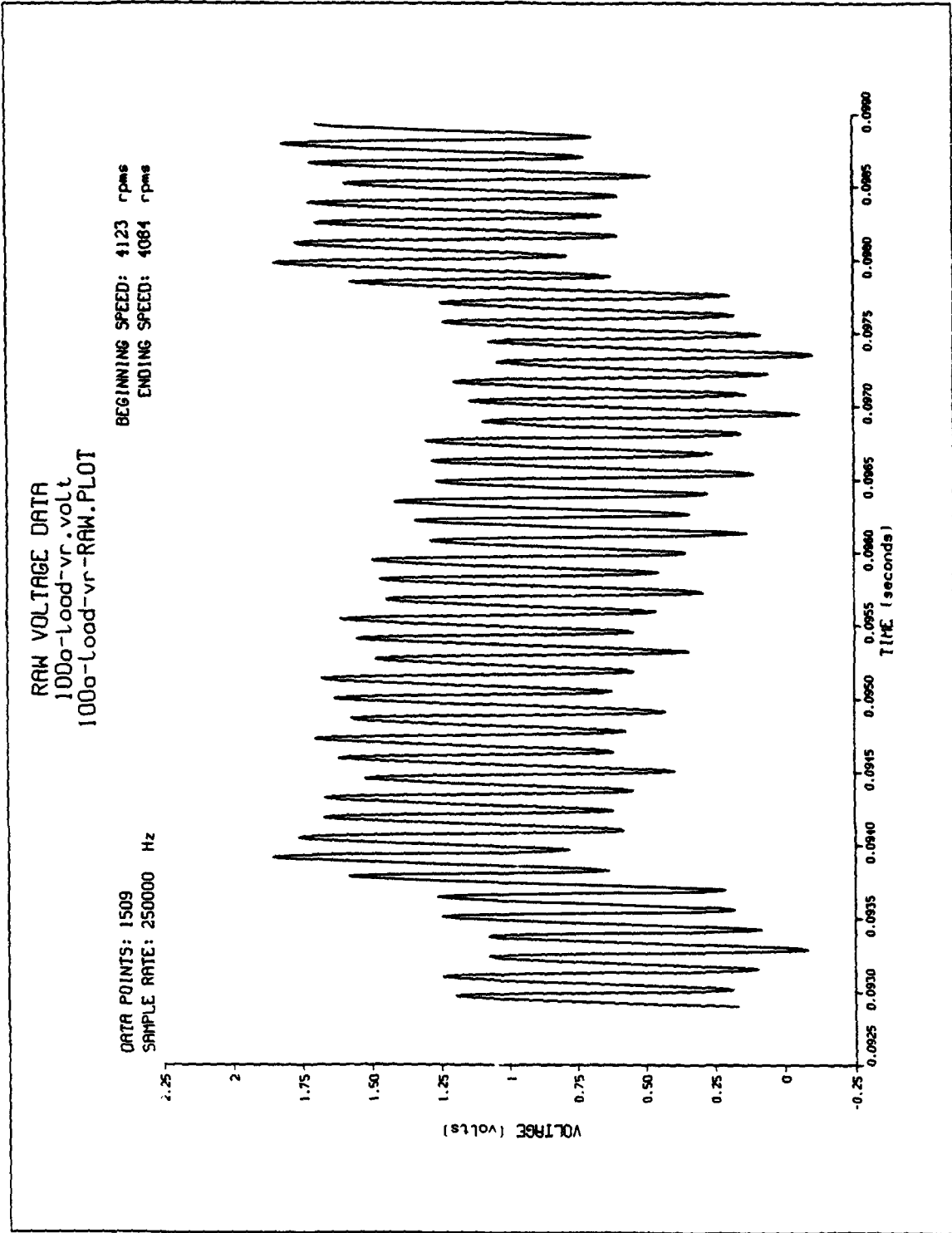

Figure 64: Ripple Voltage, 100 Amp Load, 4000 rpm

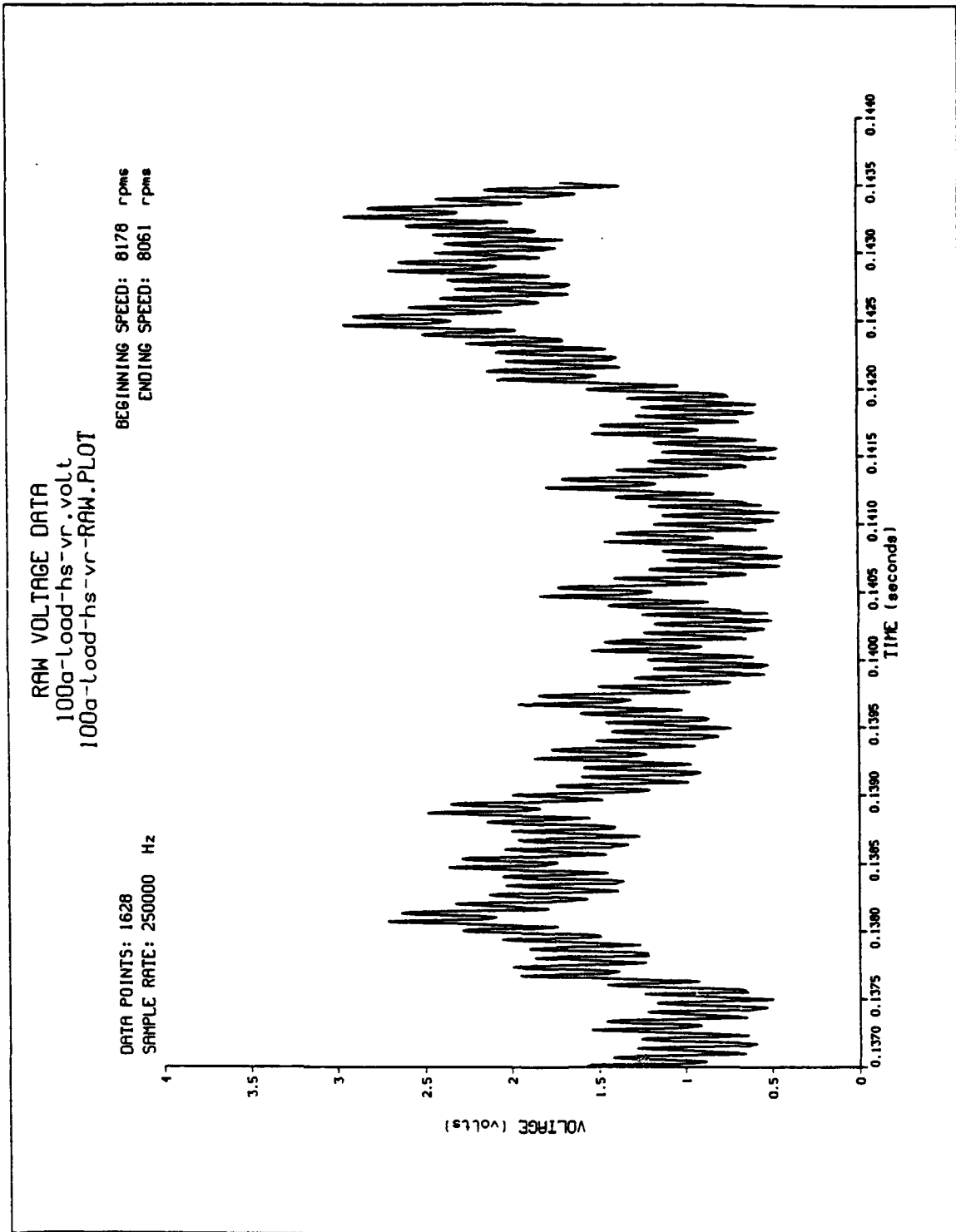

Figure 65: Ripple Voltage, 100 Amp Load, 8200 rpm

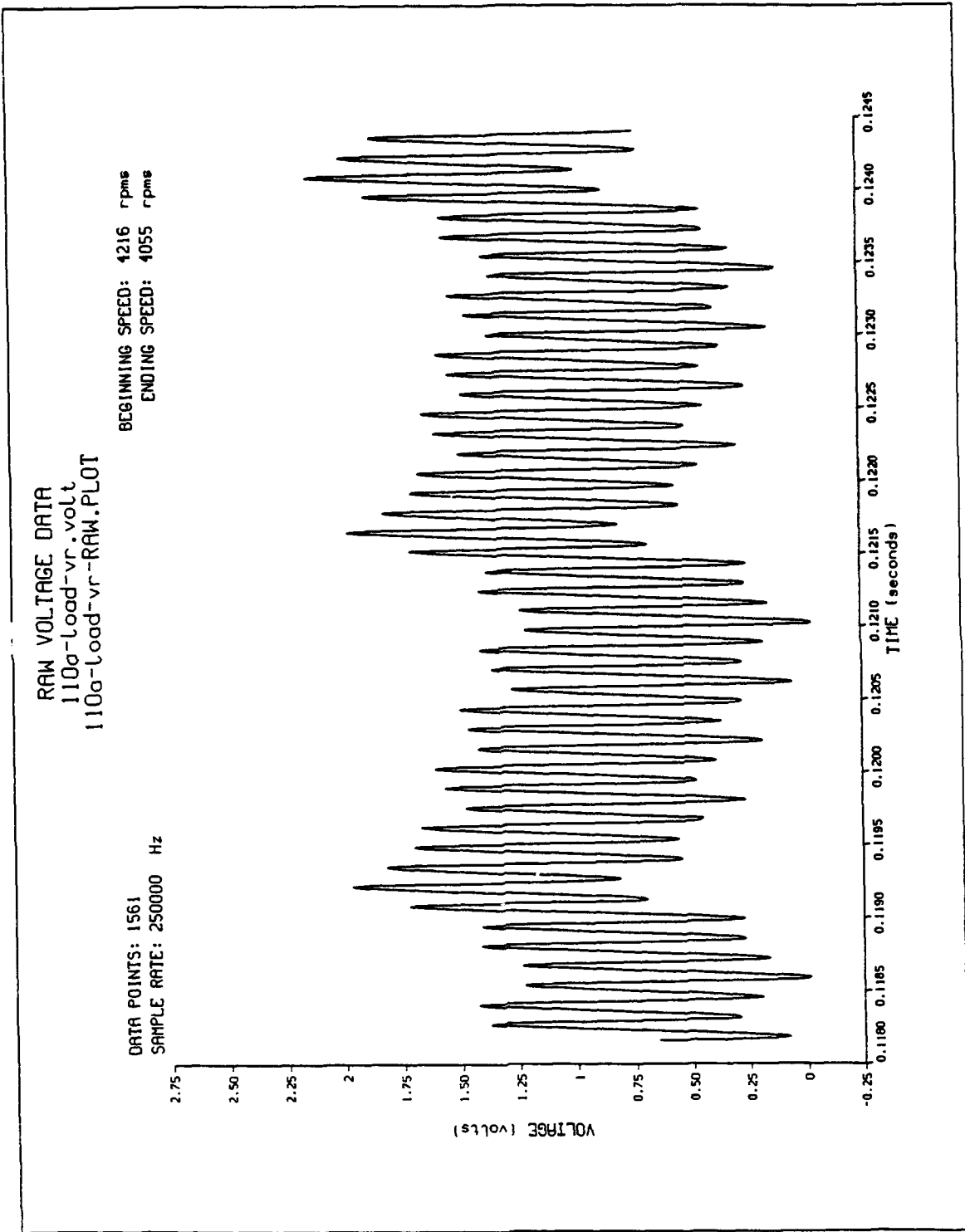

Figure 66: Ripple Voltage, 110 Amp Load, 4000 rpm

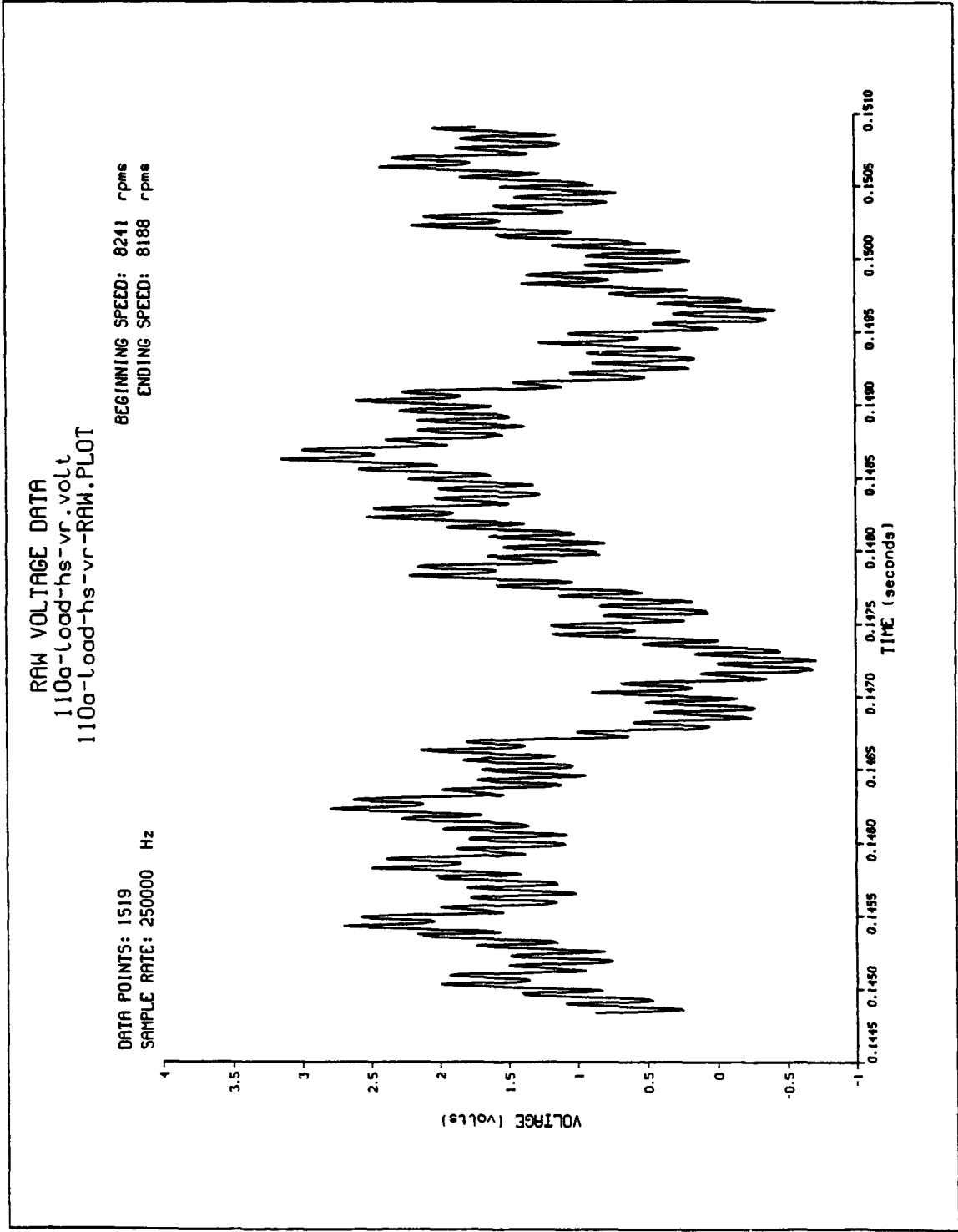

Figure 67: Ripple Voltage, 110 Amp Load, 8200 rpm

GENERATOR ACCELERATION/DECELERATION

The acceleration and deceleration test sequences measured the effect of generator speed on generator output voltage and current. These measurements were taken with the generator under full load (30 kW) while the generator was accelerated and decelerated over its specified operating range of 4000 rpm to 8200 rpm. The results can be seen in Figures 68 - 71. The figures show that generator speeds above ~7000 rpm induce higher ripple voltage magnitudes than lower generator speeds but the effect is not very significant.

DISTORTION CHARACTERISTICS

DC distortion is defined as the rms value of the alternating voltage components on the dc voltage. A distortion spectrum quantifies the distortion in terms of the amplitude of each frequency component. Distortion spectrums (Figures 72 - 83) were measured at no load, 20 A, 50 A, 80 A, 100 A, and 110 A from 10 Hz to 125 kHz. Data acquisition system limitations would not allow the distortion spectrum to be measured beyond 125 kHz. DC distortion factor is defined as the ratio of the dc distortion to the dc steady-state voltage. Measured distortion factors are tabulated in Table 4. All distortion factors are significantly less than 0.015 which is the specified limit in MIL-STD-704E for the spectrum from 10 Hz to 500 kHz. The measured distortion would still have been within the limits had it been measured over the full 10 Hz to 500 kHz spectrum since the fundamental noise of the machine was measured ~7.4 kHz for 4000 rpm machine speed and ~15 kHz for 8200 rpm machine speed. The highest measured distortion factor was 0.00291 and was measured at 110 A load with generator speed = 8200 rpm.

Table 4: Distortion Factors

Load (A)	Distortion Factor (10 Hz to 125 kHz)	
	Generator Speed = 4000 rpm	Generator Speed = 8200 rpm
0	0.00013	0.00003
20	0.00051	0.00039
50	0.00113	0.00032
80	0.00096	0.00059
100	0.00125	0.00205
110	0.00118	0.00291

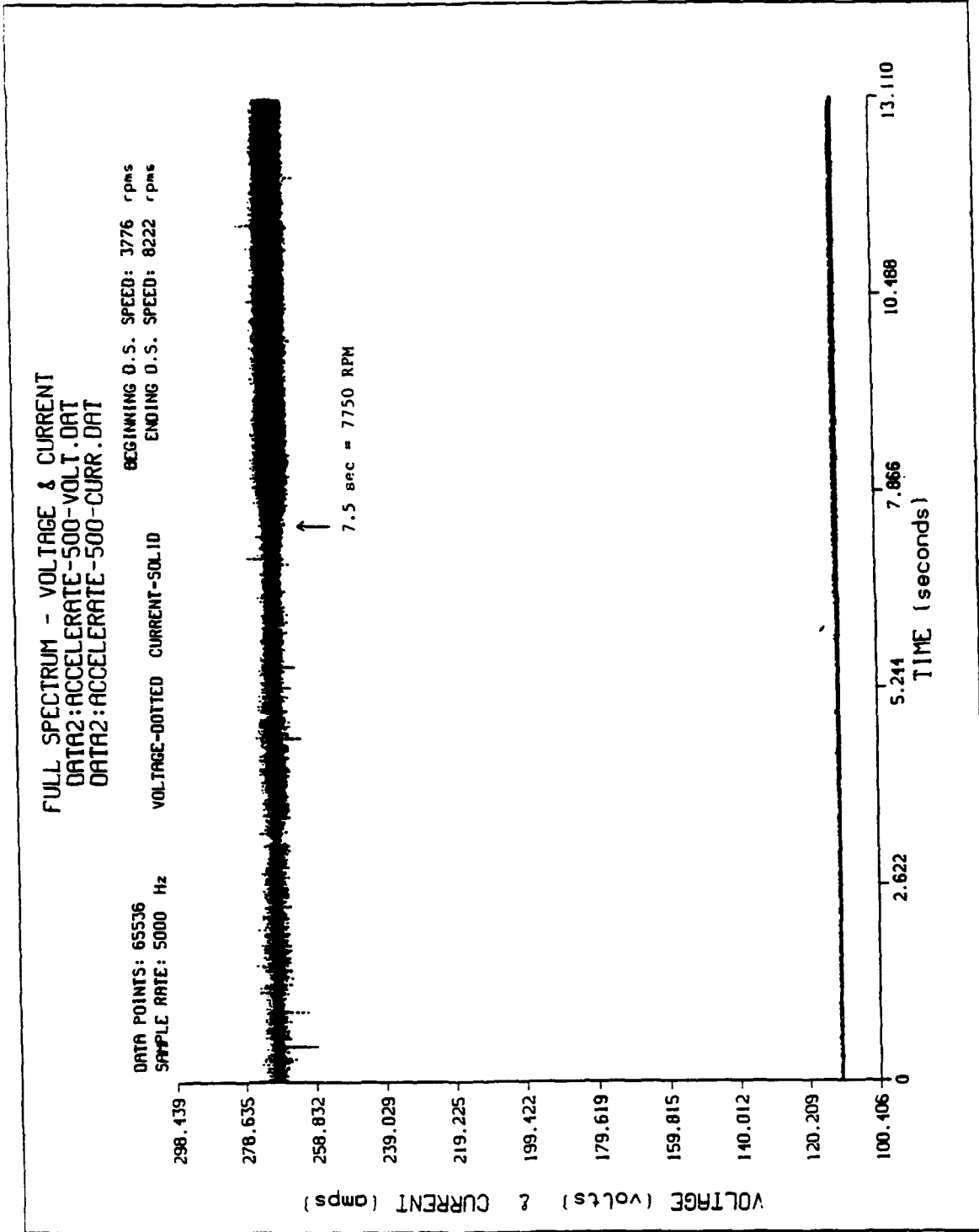

Figure 68: Generator Acceleration Under Full Load (Acceleration Rate = 500 rpm/s)

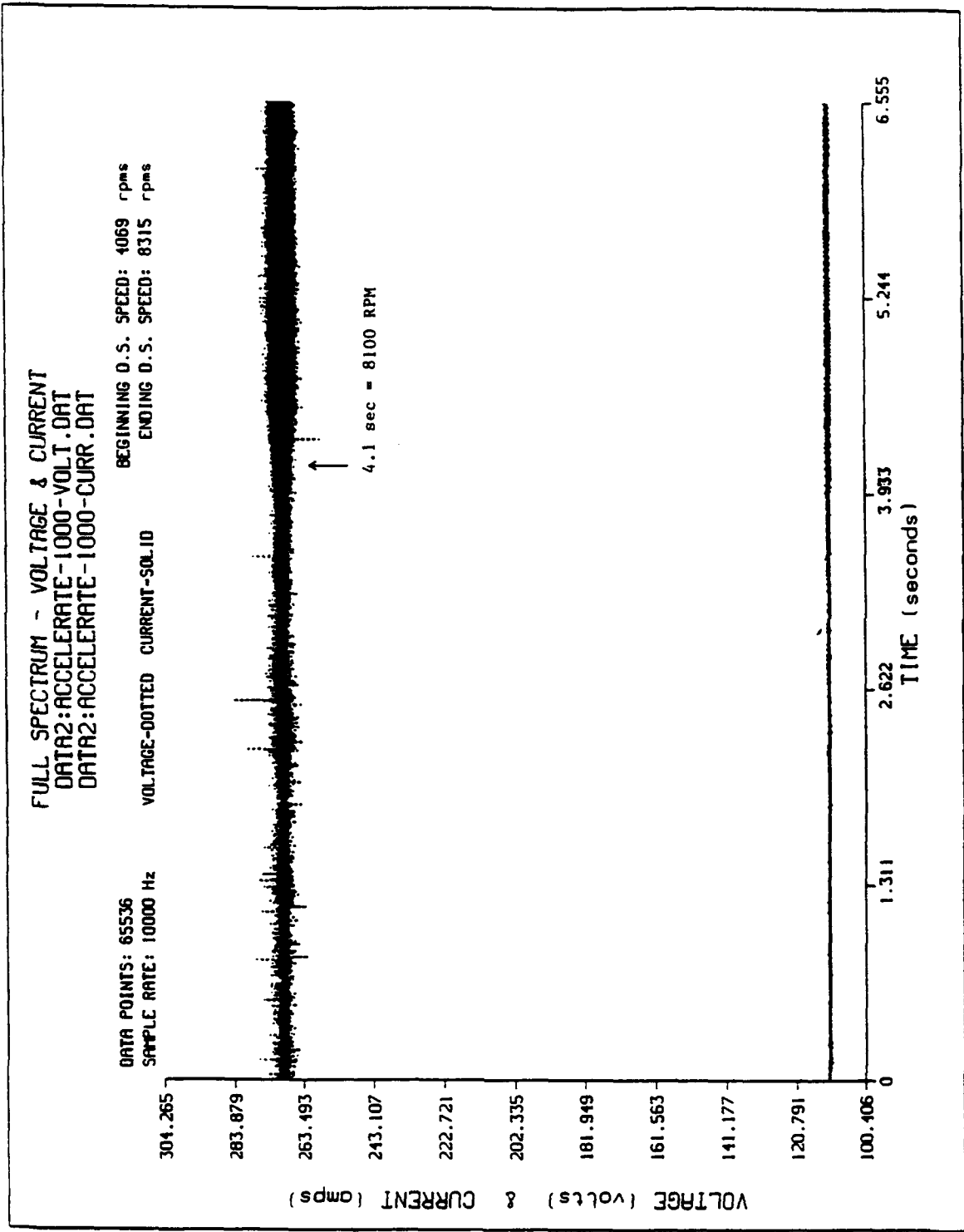

Figure 69: Generator Acceleration Under Full Load (Acceleration Rate = 1000 rpm/s)

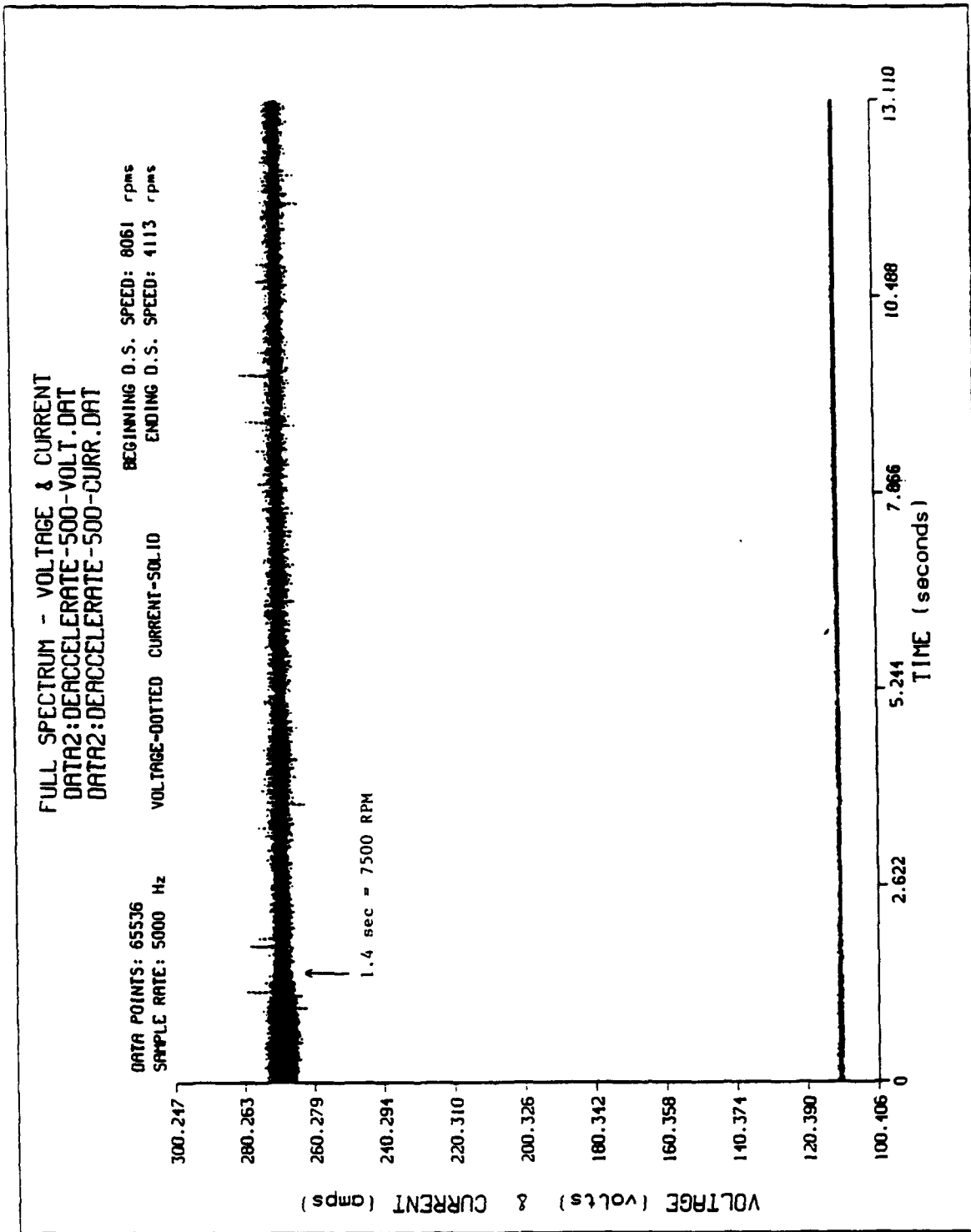

Figure 70: Generator Deceleration Under Full Load (Deceleration Rate = 500 rpm/s)

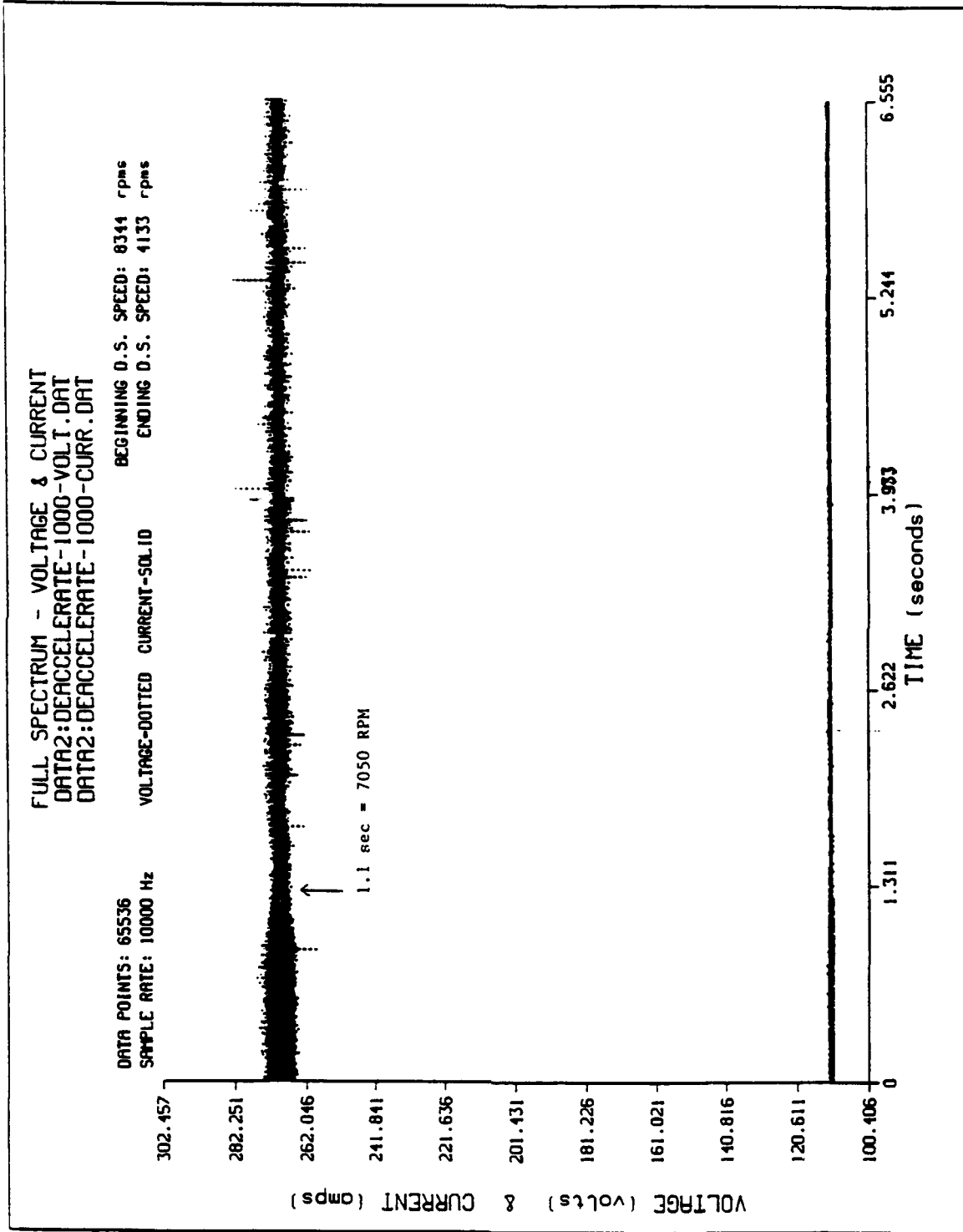

Figure 71: Generator Deceleration Under Full Load (Deceleration Rate = 1000 rpm/s)

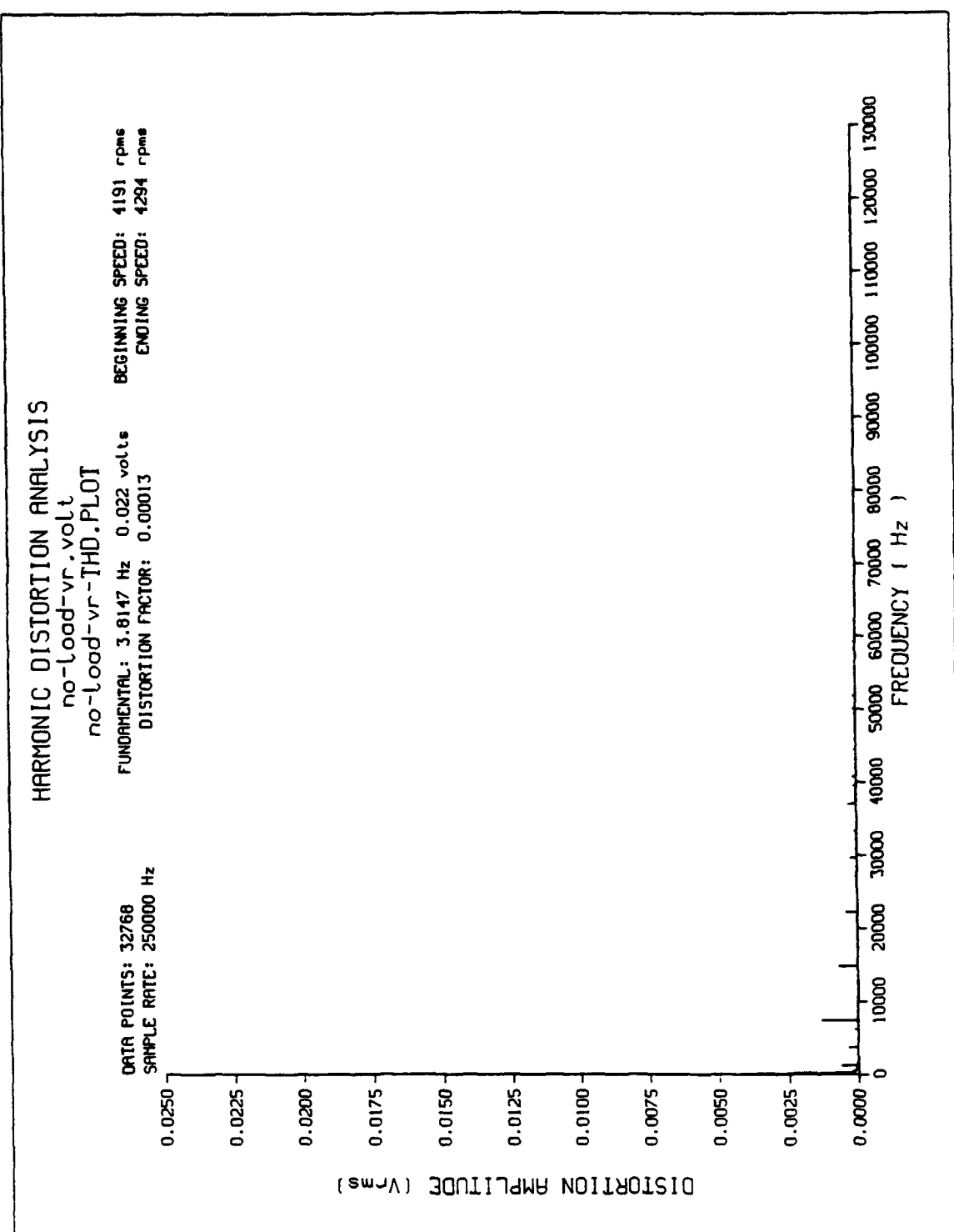

Figure 72: No Load 4000 rpm Distortion Spectrum

HARMONIC DISTORTION ANALYSIS

no-Load-hs-vr.volt
no-Load-hs-vr-THD.PLOT

FUNDAMENTAL: 26.703 Hz 0.034 volts
DISTORTION FACTOR: 0.00003

DATA POINTS: 32768
SAMPLE RATE: 250000 Hz

BEGINNING SPEED: 8290 rpms
ENDING SPEED: 8315 rpms

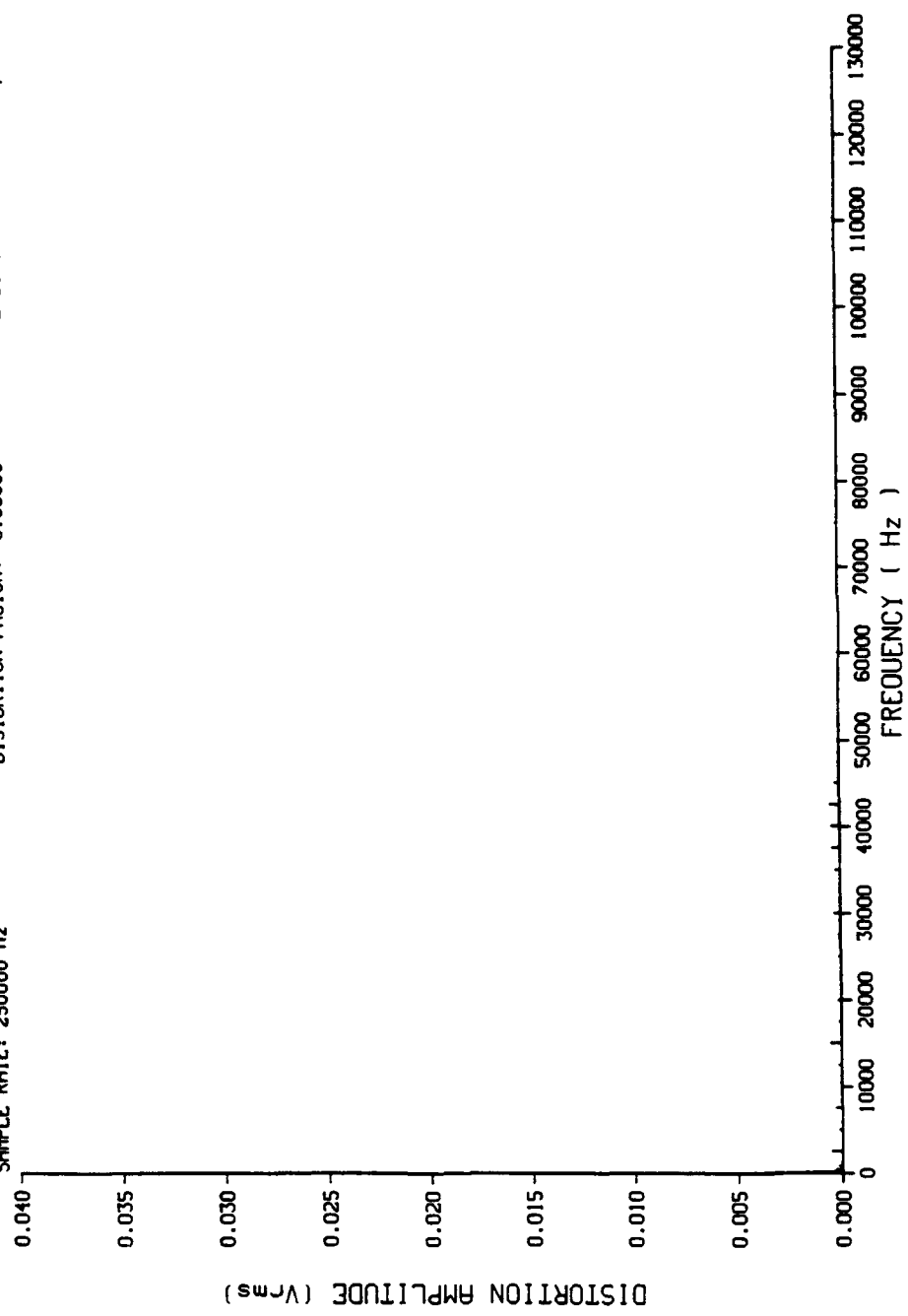

Figure 73: No Load 8200 rpm Distortion Spectrum

HARMONIC DISTORTION ANALYSIS

20a-load-vr.volt
20a-load-vr-THD.PLOT

DATA POINTS: 32768
SAMPLE RATE: 250000 Hz

FUNDAMENTAL: 7412.0 Hz 0.559 volts
DISTORTION FACTOR: 0.00051

BEGINNING SPEED: 4289 rpms
ENDING SPEED: 4045 rpms

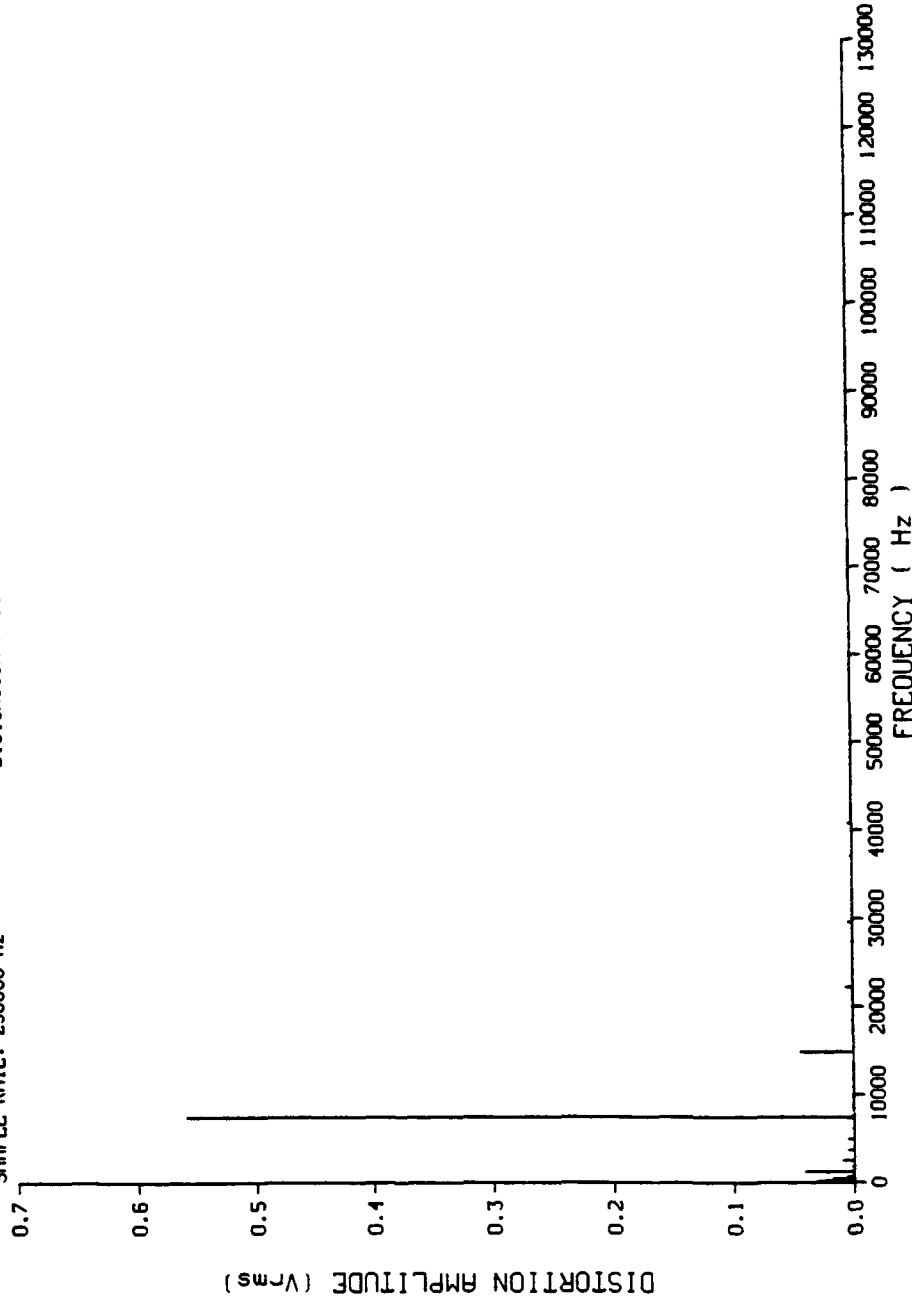

Figure 74: Distortion Spectrum, 20 Amp Load, 4000 rpm

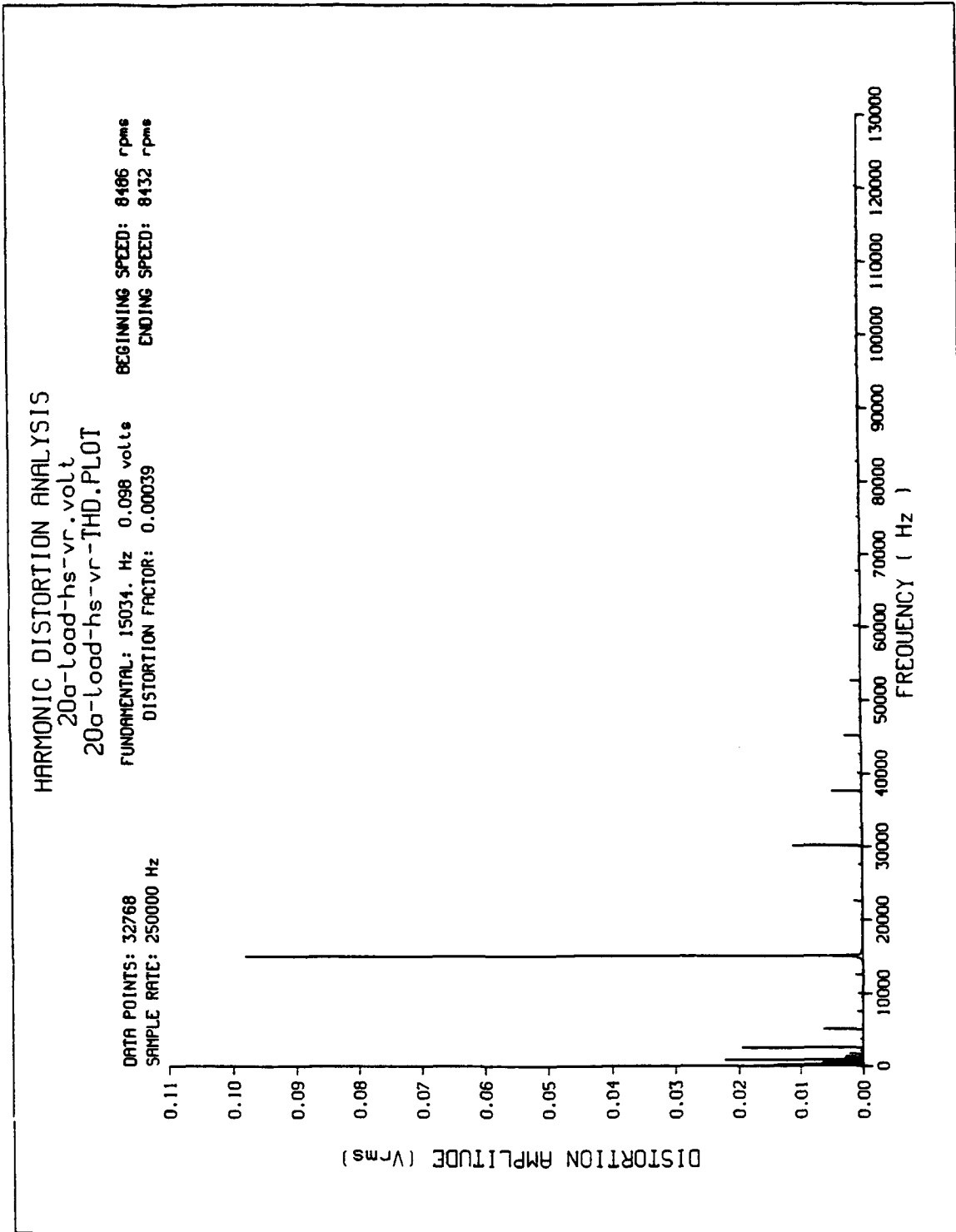

Figure 75: Distortion Spectrum, 20 Amp Load, 8200 rpm

HARMONIC DISTORTION ANALYSIS

50a-Load-vr.volt

50a-Load-vr-THD.PLOT

BEGINNING SPEED: 4064 rpm
ENDING SPEED: 4035 rpm

FUNDAMENTAL: 7400.5 Hz 0.406 volts
DISTORTION FACTOR: 0.00113

DATA POINTS: 32768
SAMPLE RATE: 250000 Hz

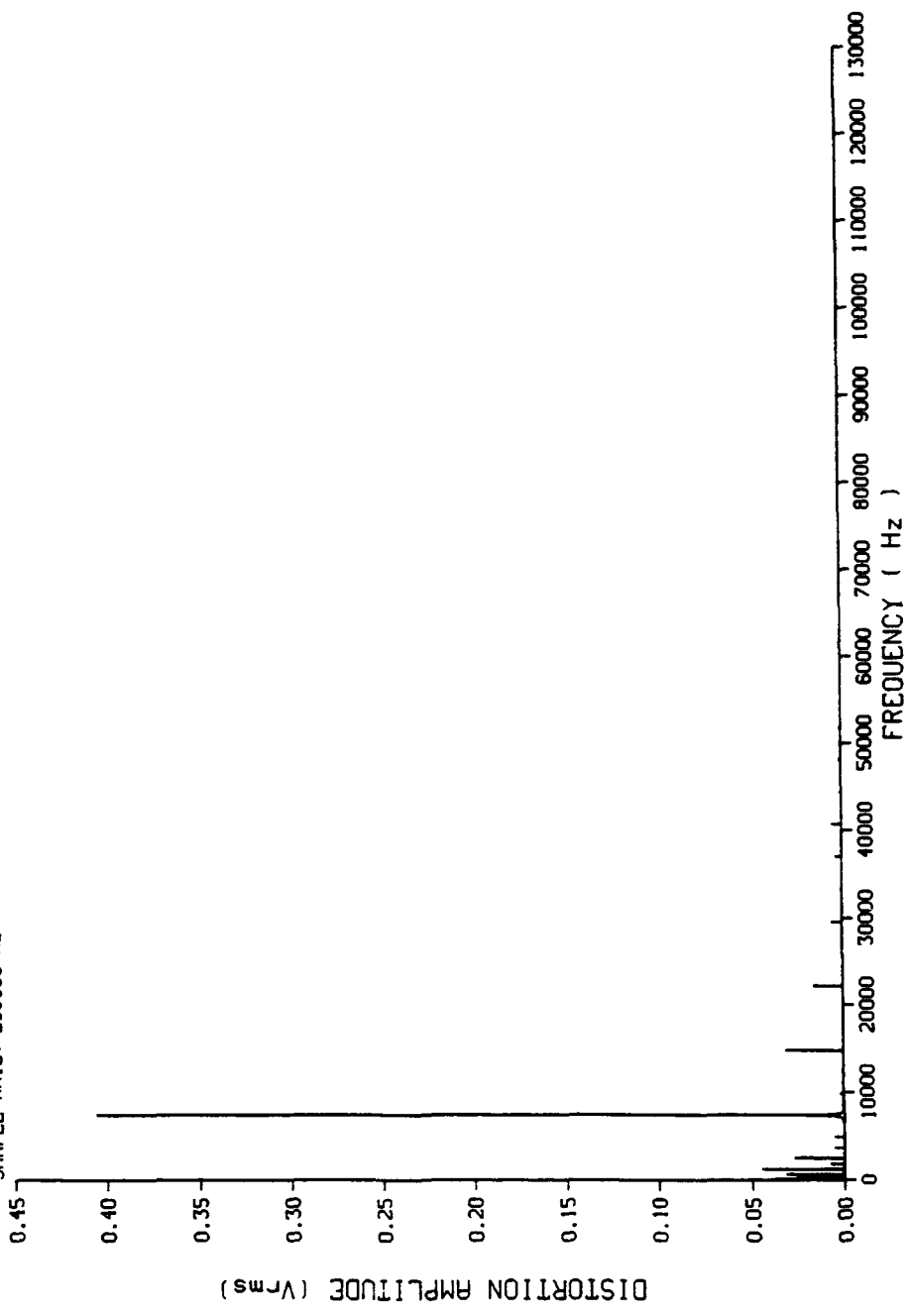

Figure 76: Distortion Spectrum, 50 Amp Load, 4000 rpm

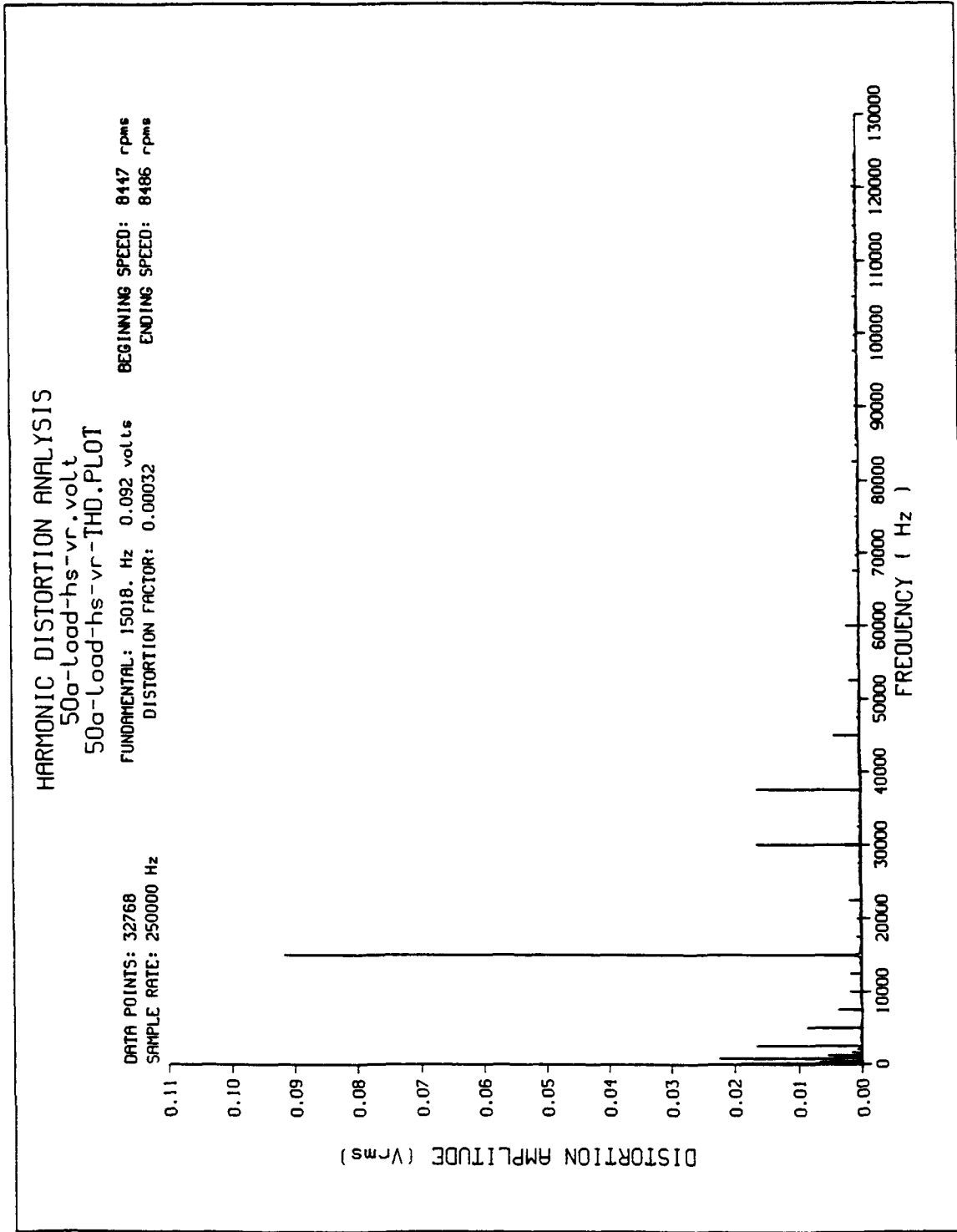

Figure 77: Distortion Spectrum, 50 Amp Load, 8200 rpm

HARMONIC DISTORTION ANALYSIS

80a-load-vr.volt

80a-load-vr-THD.PLOT

FUNDAMENTAL: 7366.2 Hz 0.311 volts
DISTORTION FACTOR: 0.00096

DATA POINTS: 32768
SAMPLE RATE: 250000 Hz

BEGINNING SPEED: 3786 rpm
ENDING SPEED: 3933 rpm

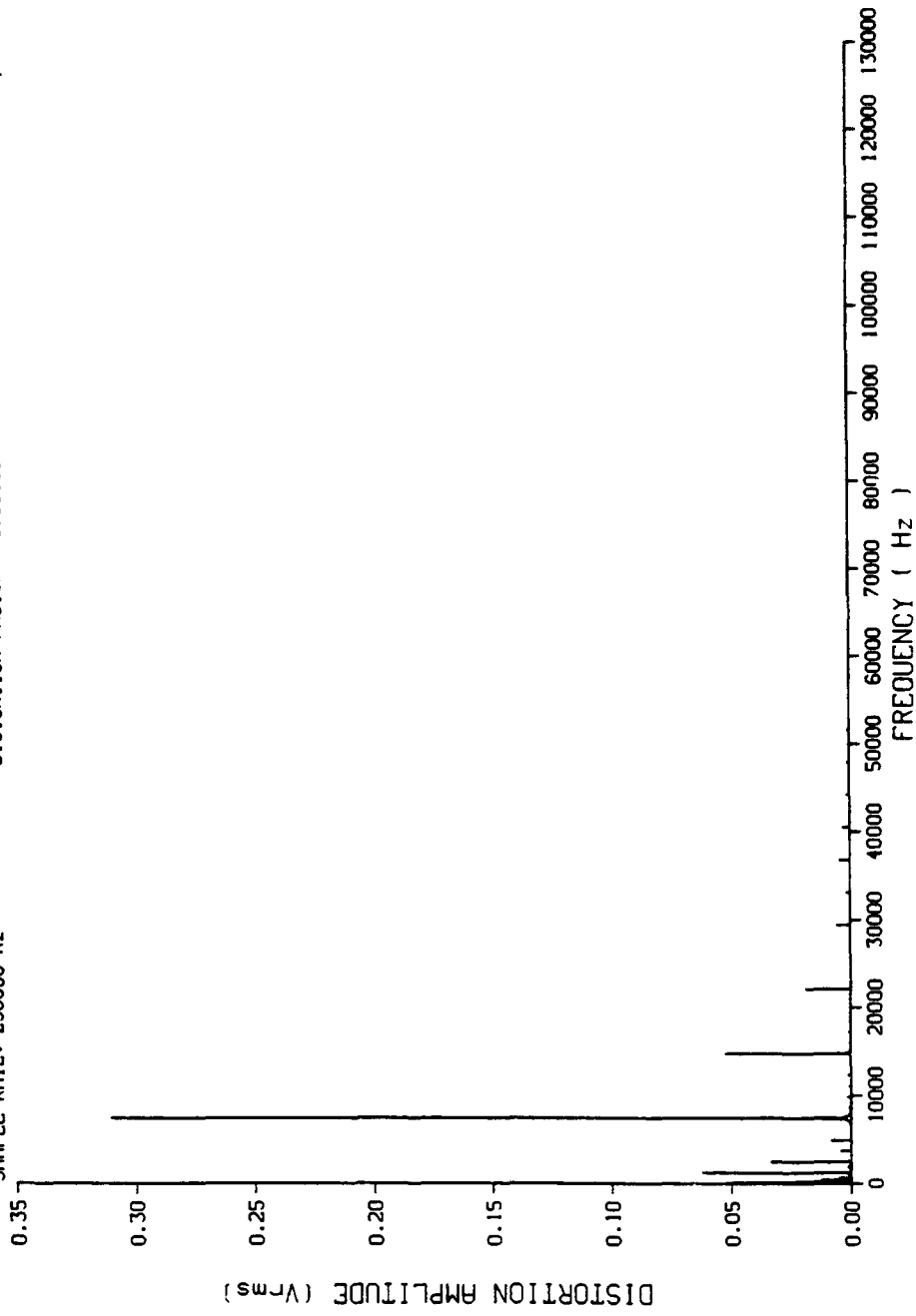

Figure 78: Distortion Spectrum, 80 Amp Load, 4000 rpm

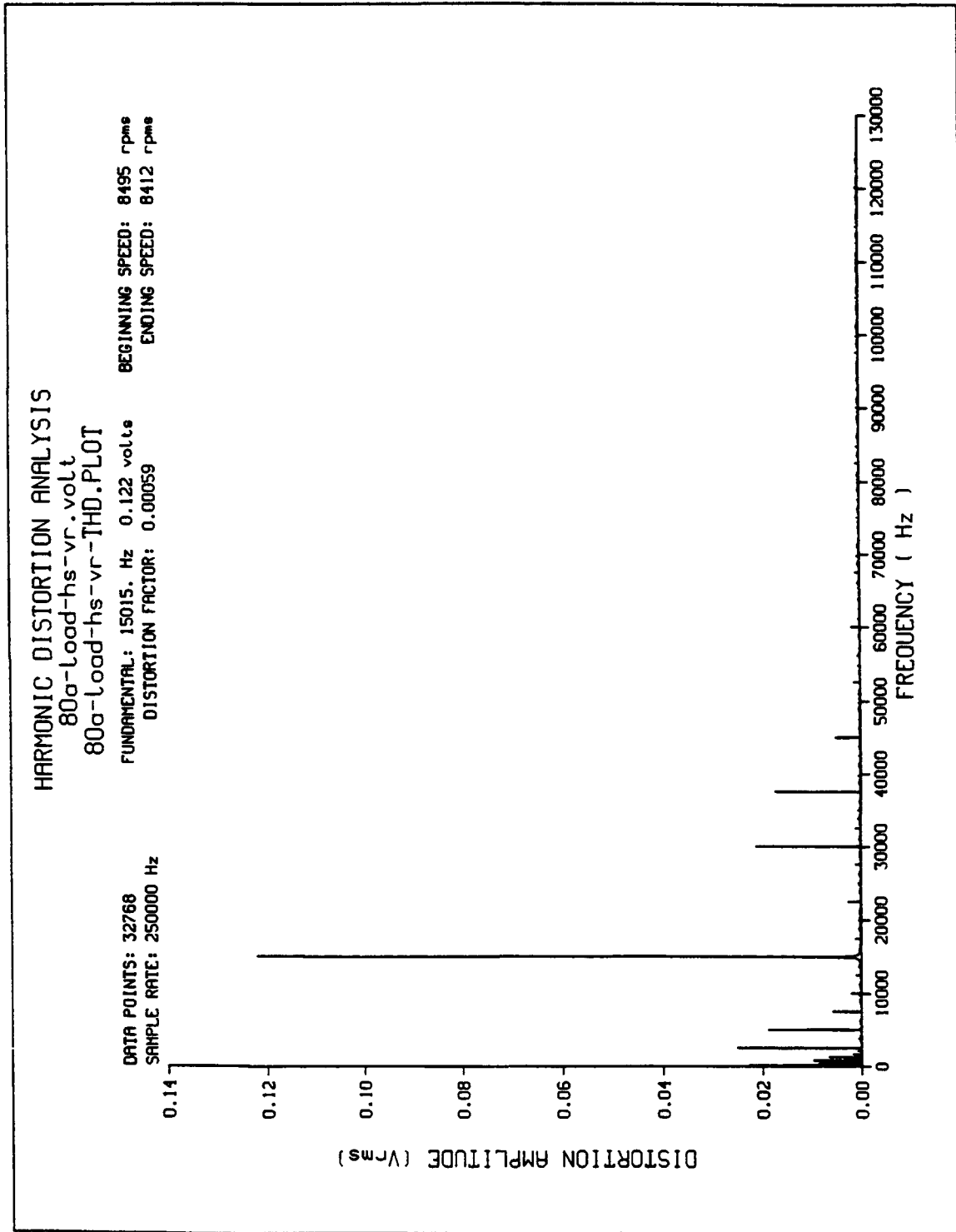

Figure 79: Distortion Spectrum, 80 Amp Load, 8200 rpm

HARMONIC DISTORTION ANALYSIS
100 α -Load-vr.volt
100 α -Load-vr-THD.PLOT

FUNDAMENTAL: 7381.4 Hz 0.324 volts
DISTORTION FACTOR: 0.00125

DATA POINTS: 32768
SAMPLE RATE: 250000 Hz

BEGINNING SPEED: 4123 rpms
ENDING SPEED: 4084 rpms

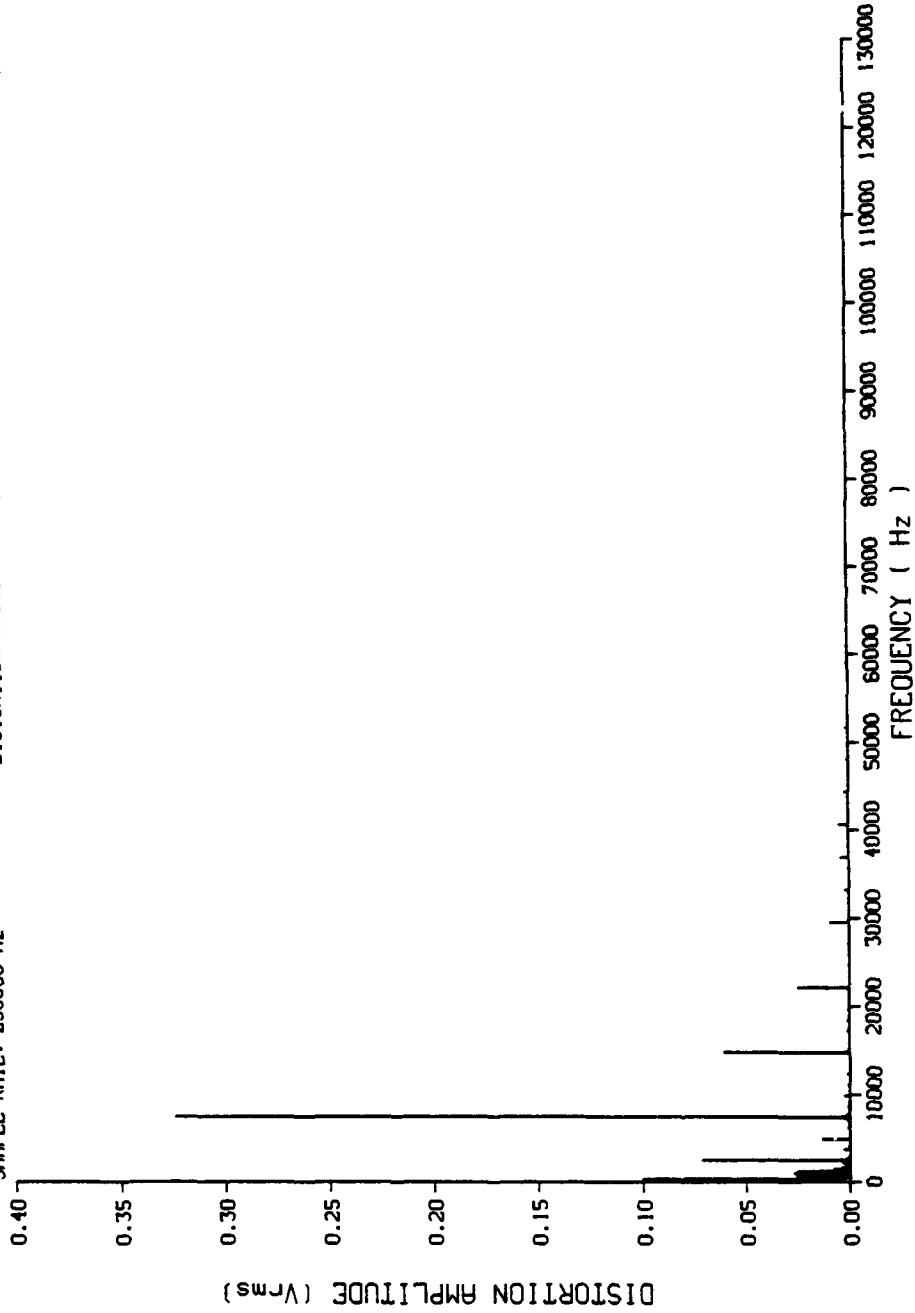

Figure 80: Distortion Spectrum, 100 Amp Load, 4000 rpm

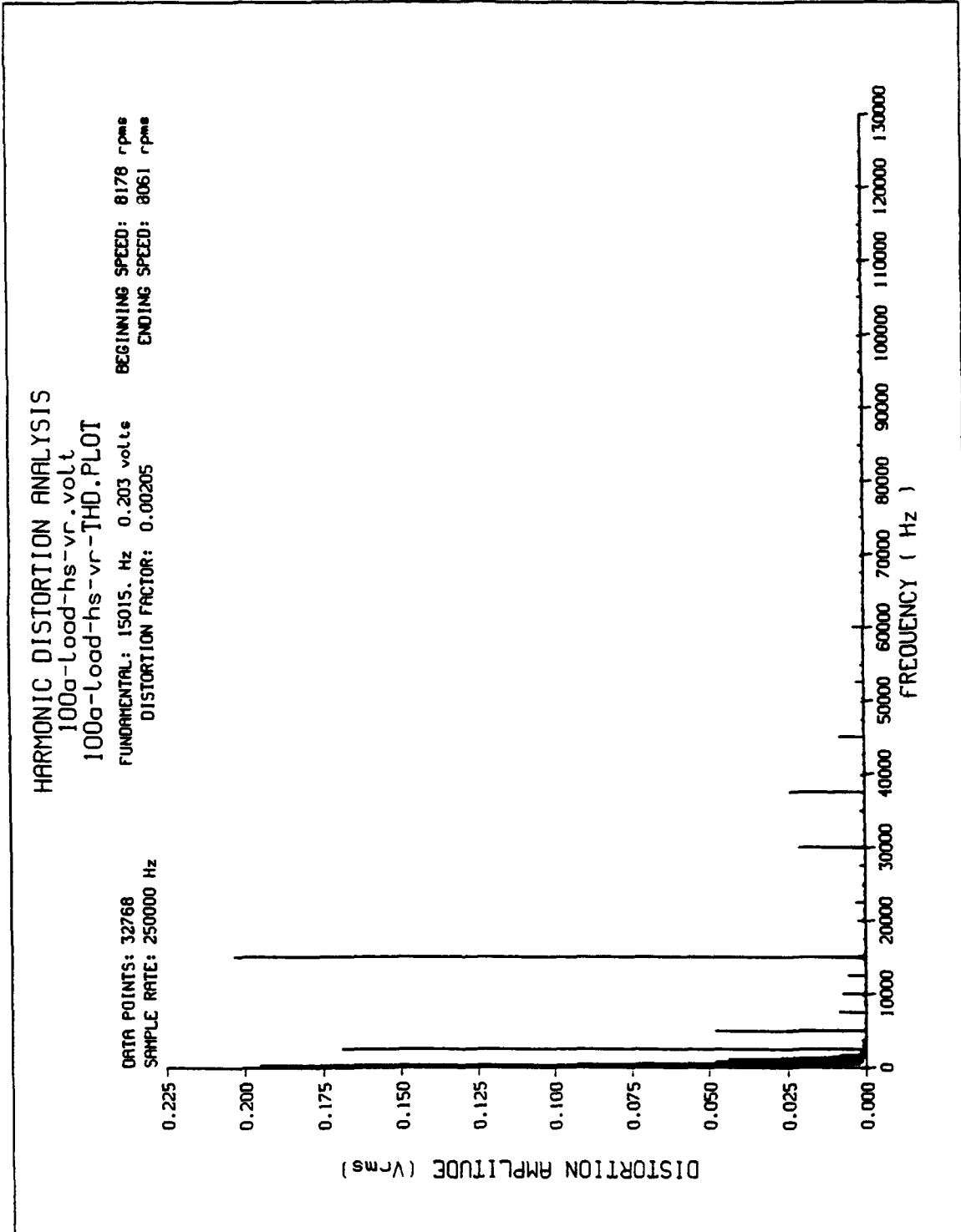

Figure 81: Distortion Spectrum, 100 Amp Load, 8200 rpm

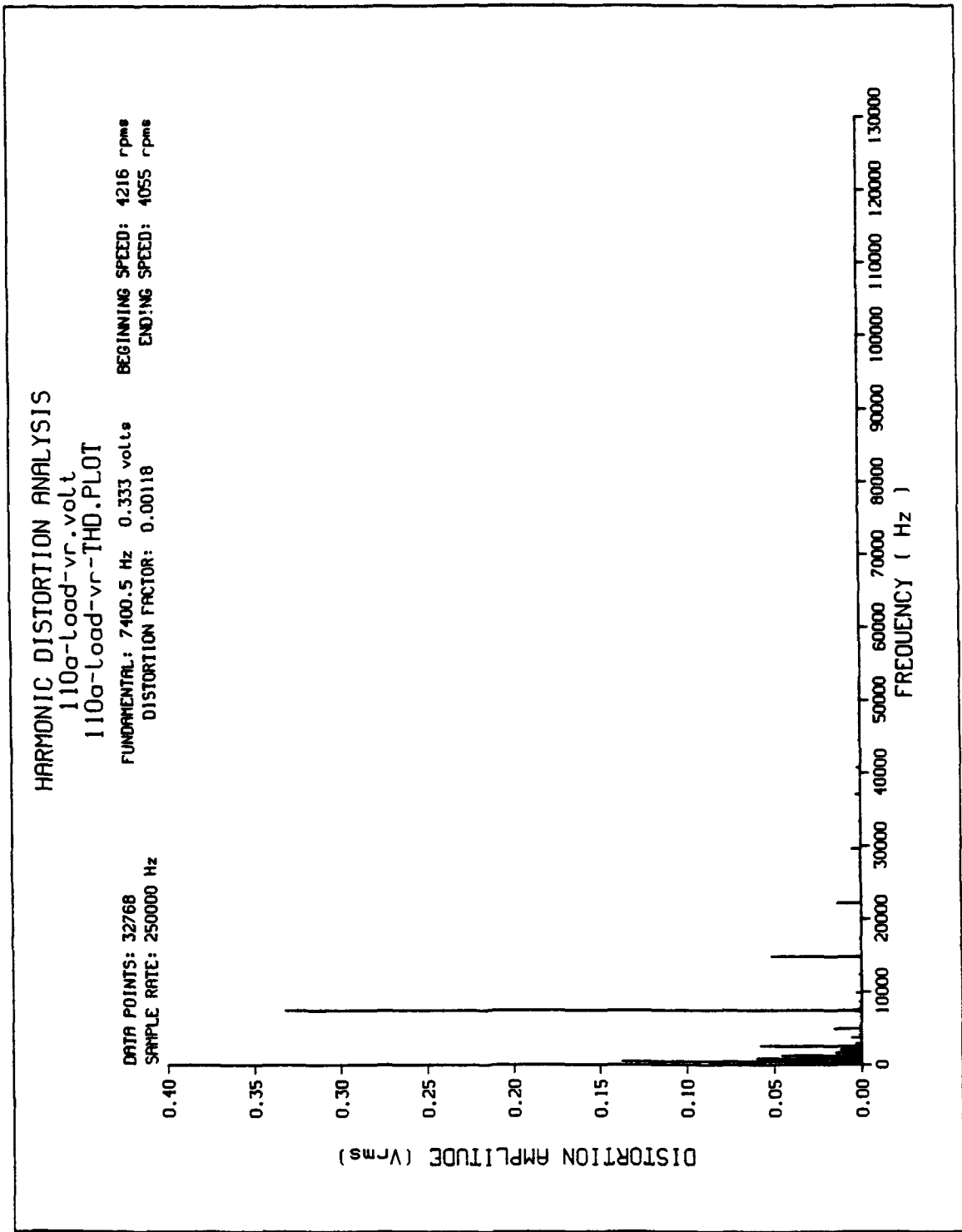

Figure 82: Distortion Spectrum, 110 Amp Load, 4000 rpm

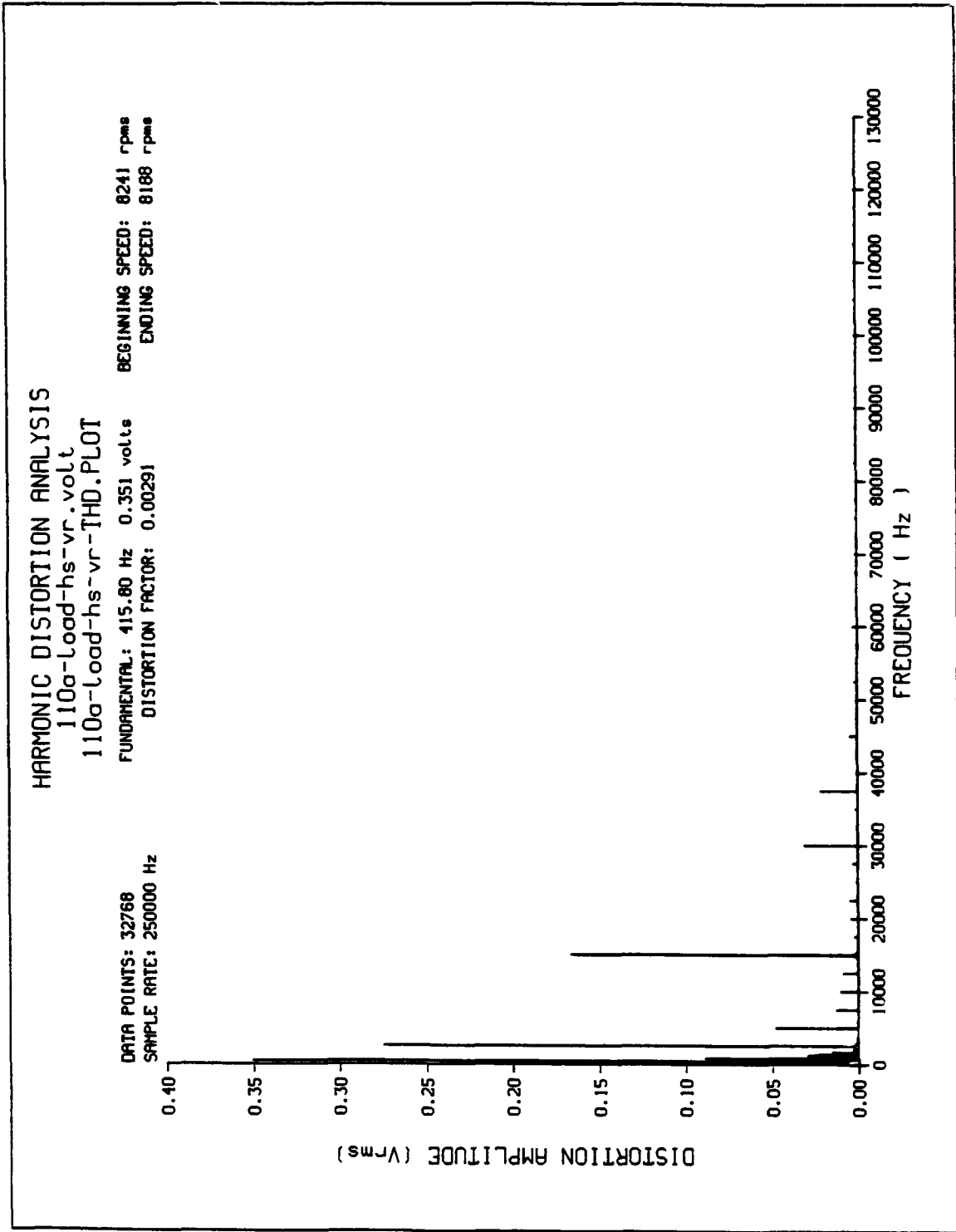

Figure 83: Distortion Spectrum, 110 Amp Load, 8200 rpm

FAULT CURRENT

Generator fault currents were measured when short circuits were applied across the output terminals of the generator. Voltage and current data was recorded during these test sequence executions. The results are plotted in Figures 84 - 89. With generator speed at 4000 rpm, the peak fault current was 358 A (Figure 85) before the GCU current limit circuitry activated and with generator speed at 8200 rpm, the peak fault current was 276 A (Figure 88). In both cases, the generator system current limit circuitry limited the generator output current to 168 A (Figures 84 and 87) and cleared the fault current after 5.04 seconds.

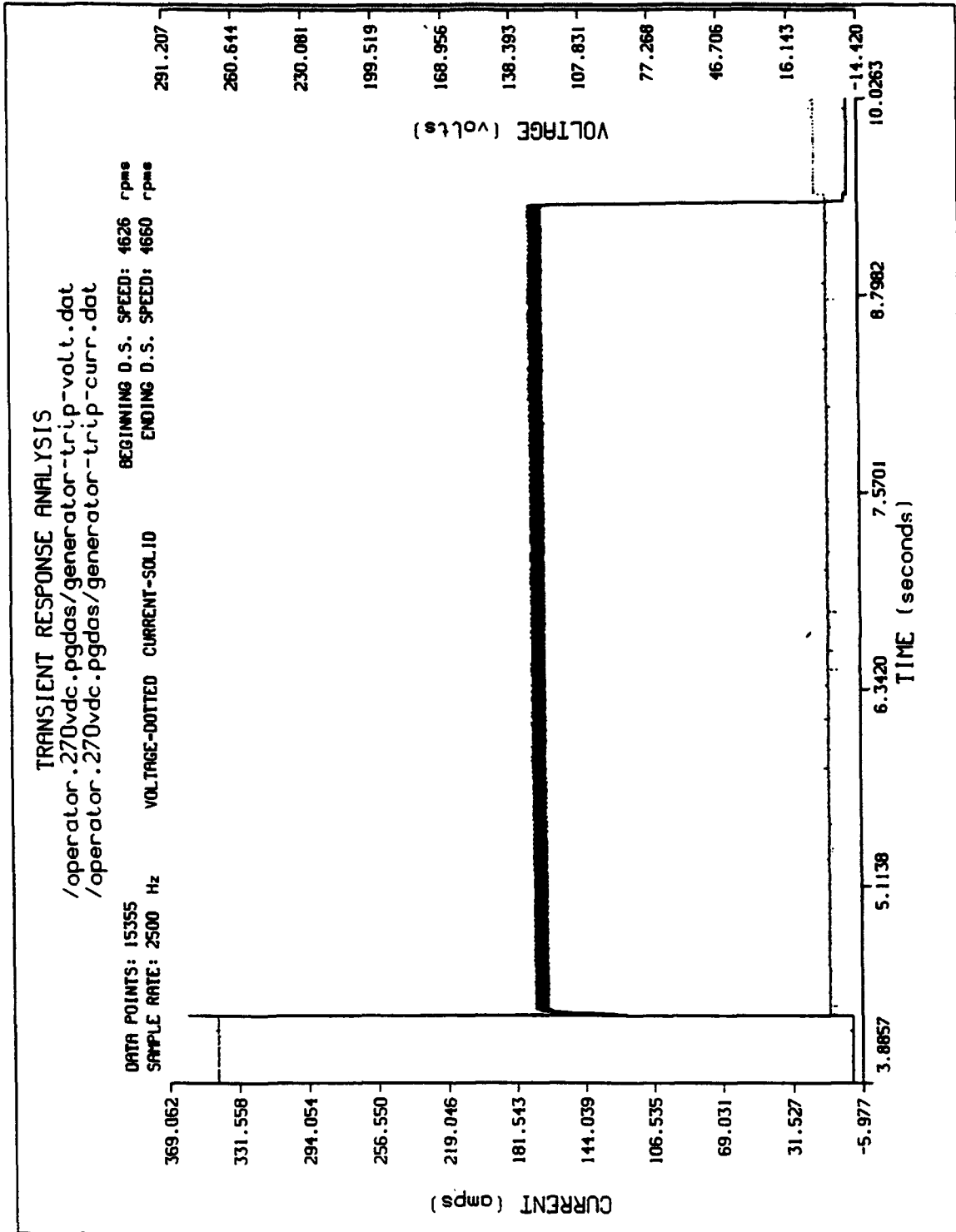

Figure 84: Generator Short Circuit Fault Sequence, 4000 rpm

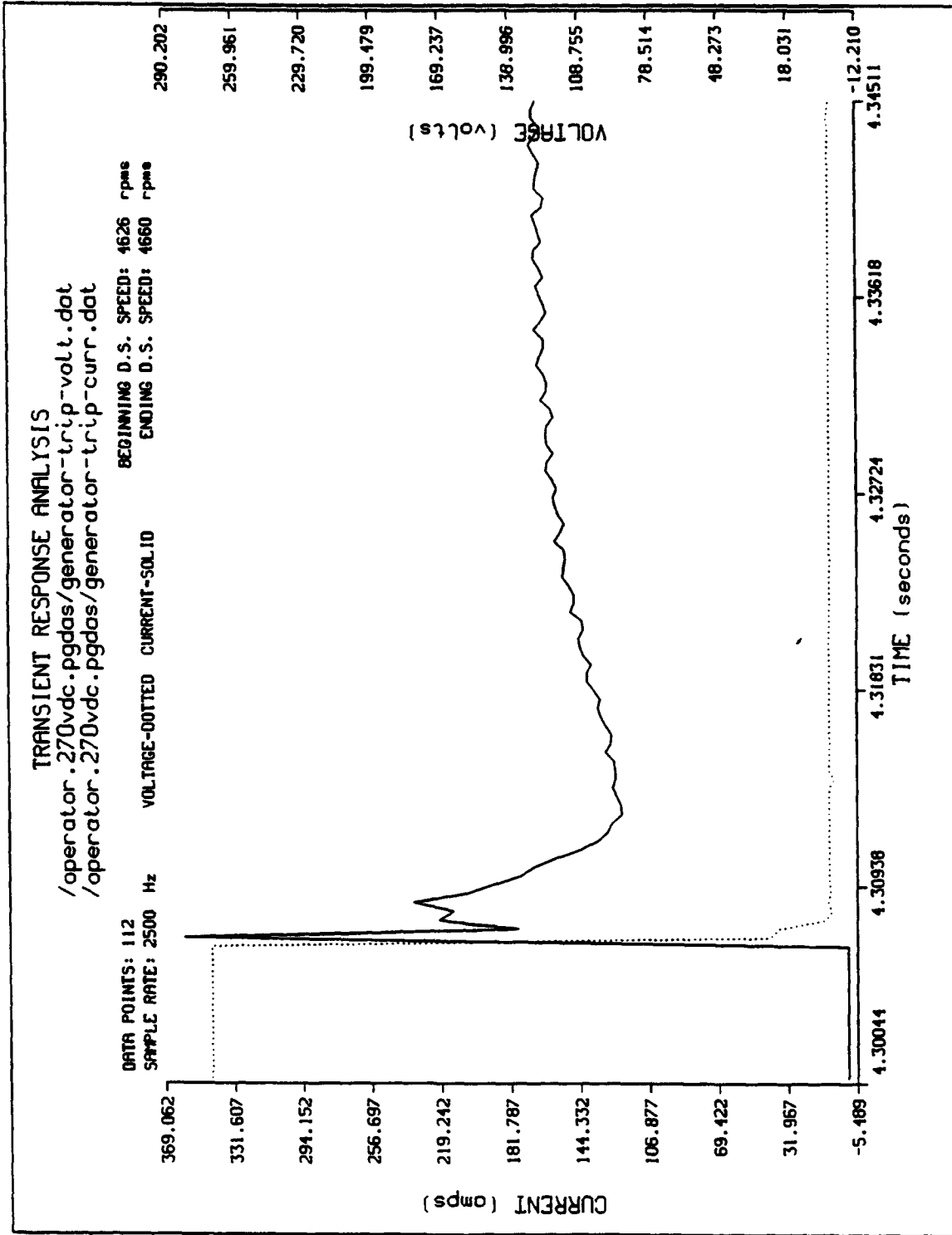

Figure 85: Short Circuit Fault Application, 4000 rpm

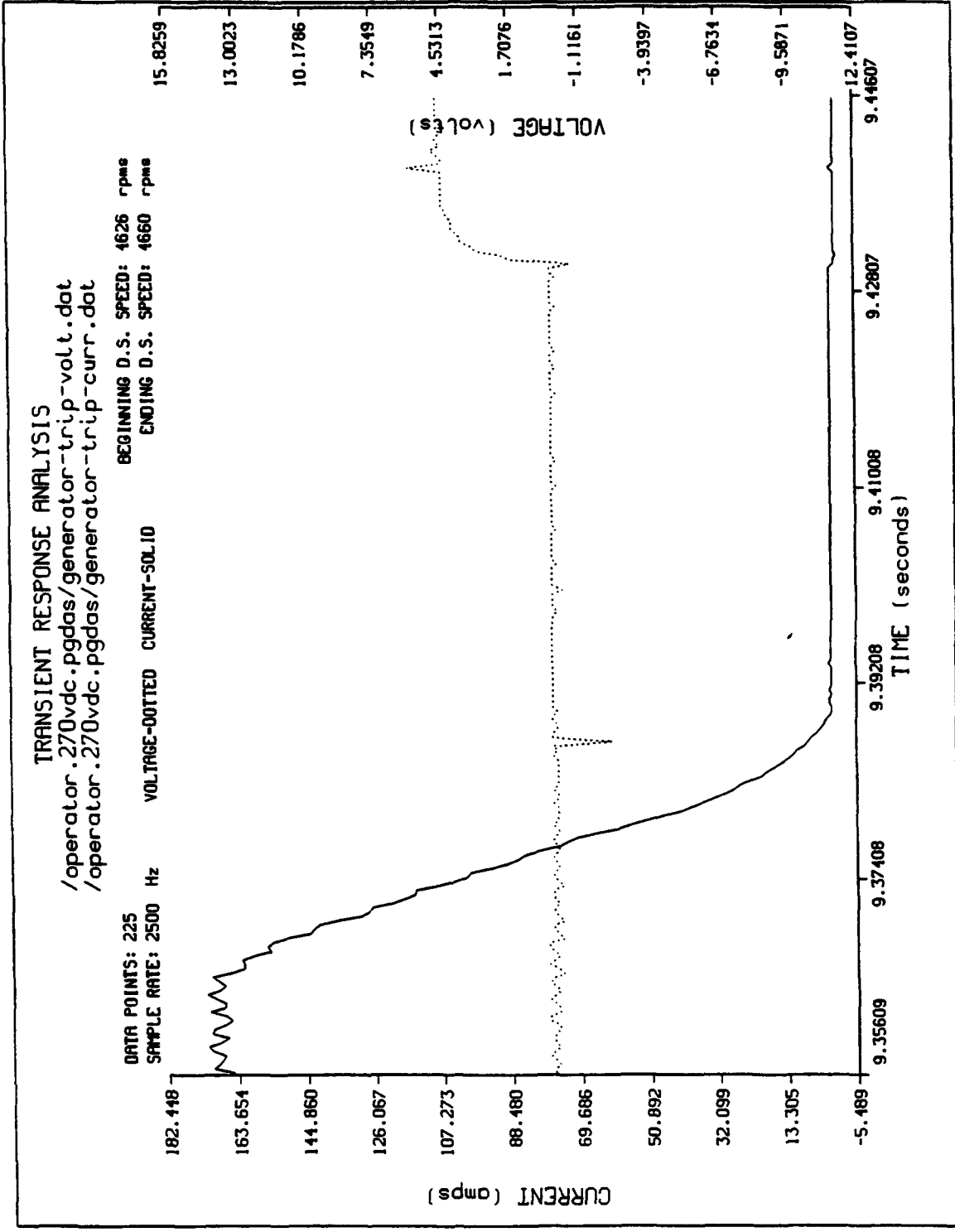

Figure 86: Generator Trip / Fault Clear, 4000 rpm

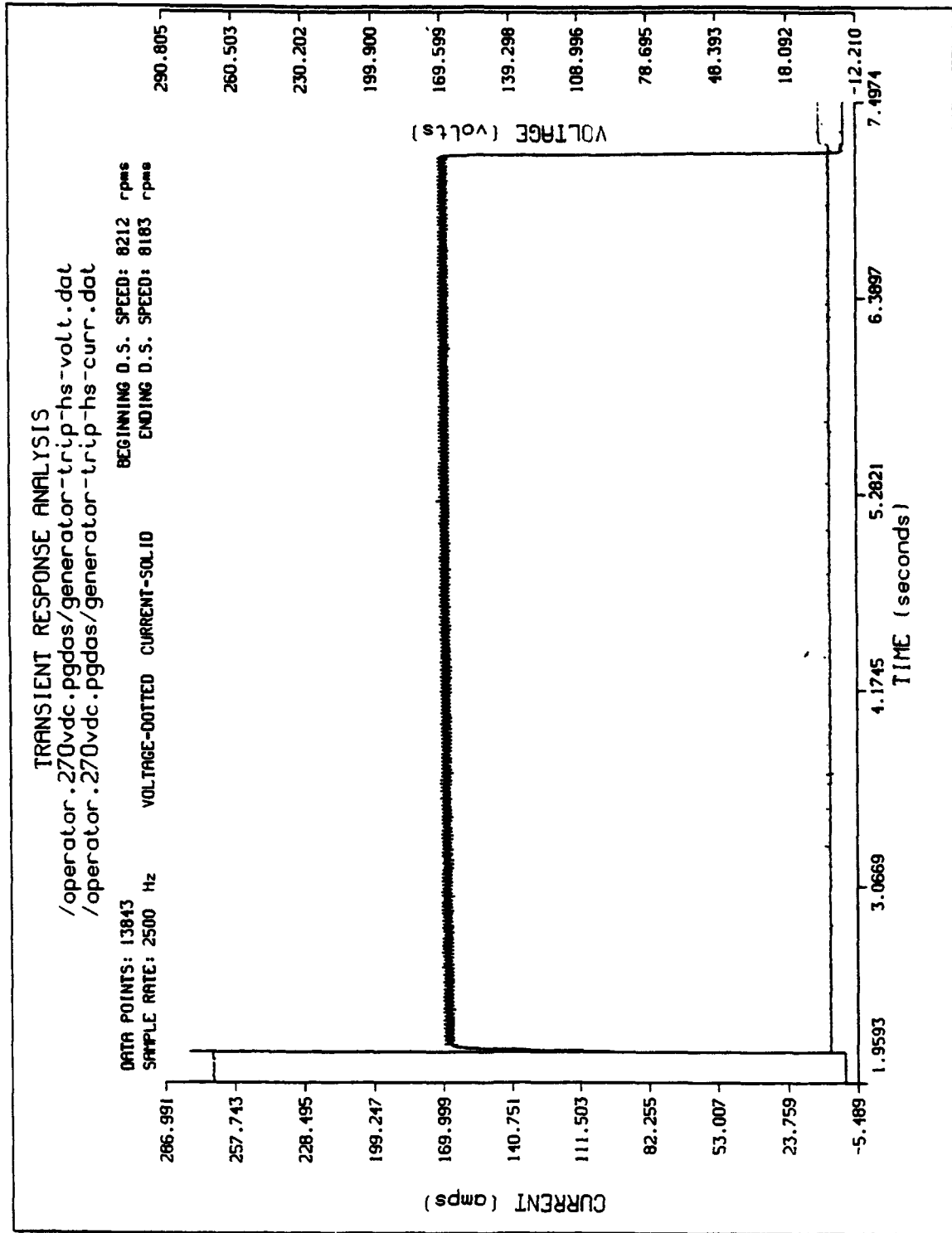

Figure 87: Generator Short Circuit Fault Sequence, 8200 rpm

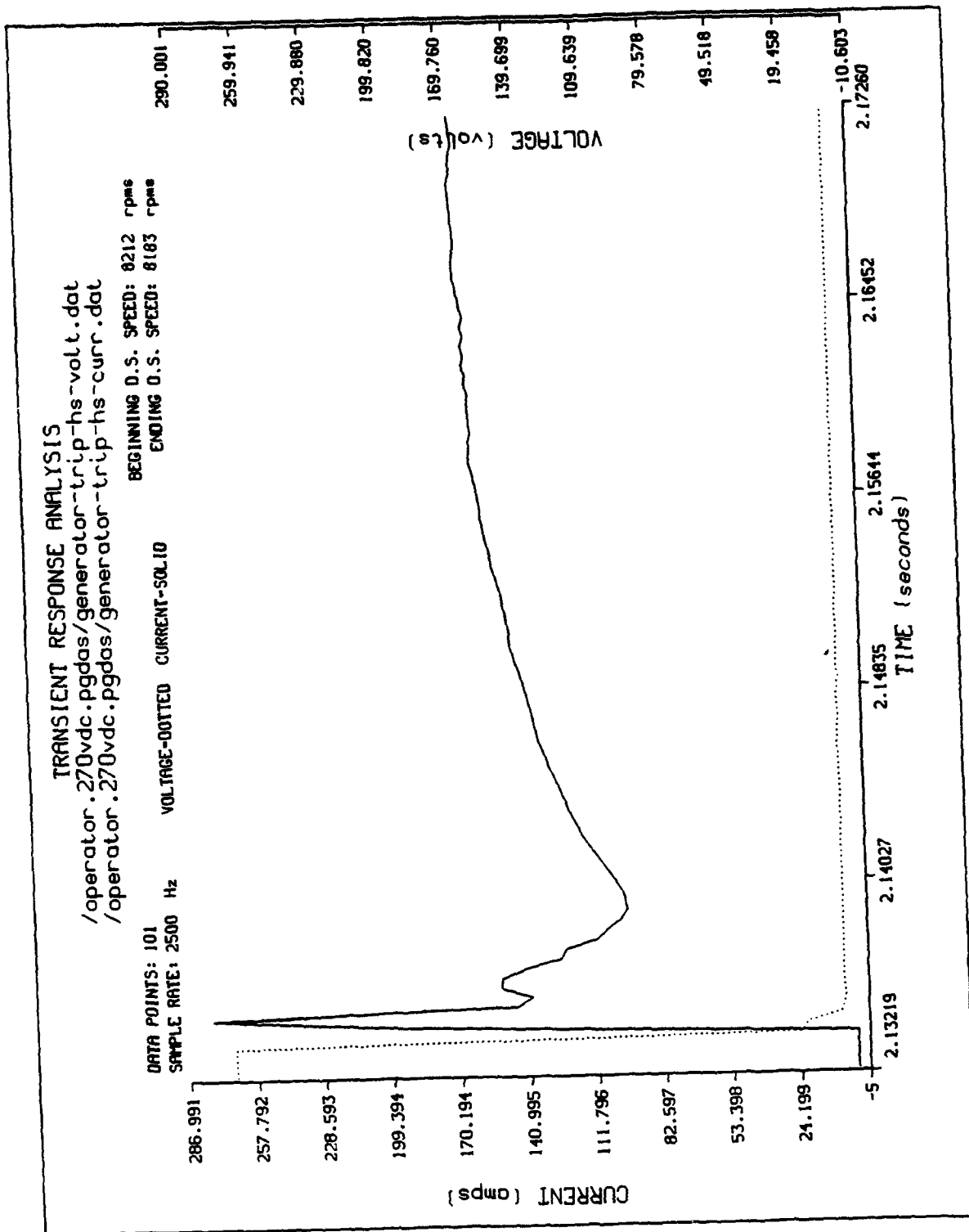

Figure 88: Short Circuit Fault Application, 8200 rpm

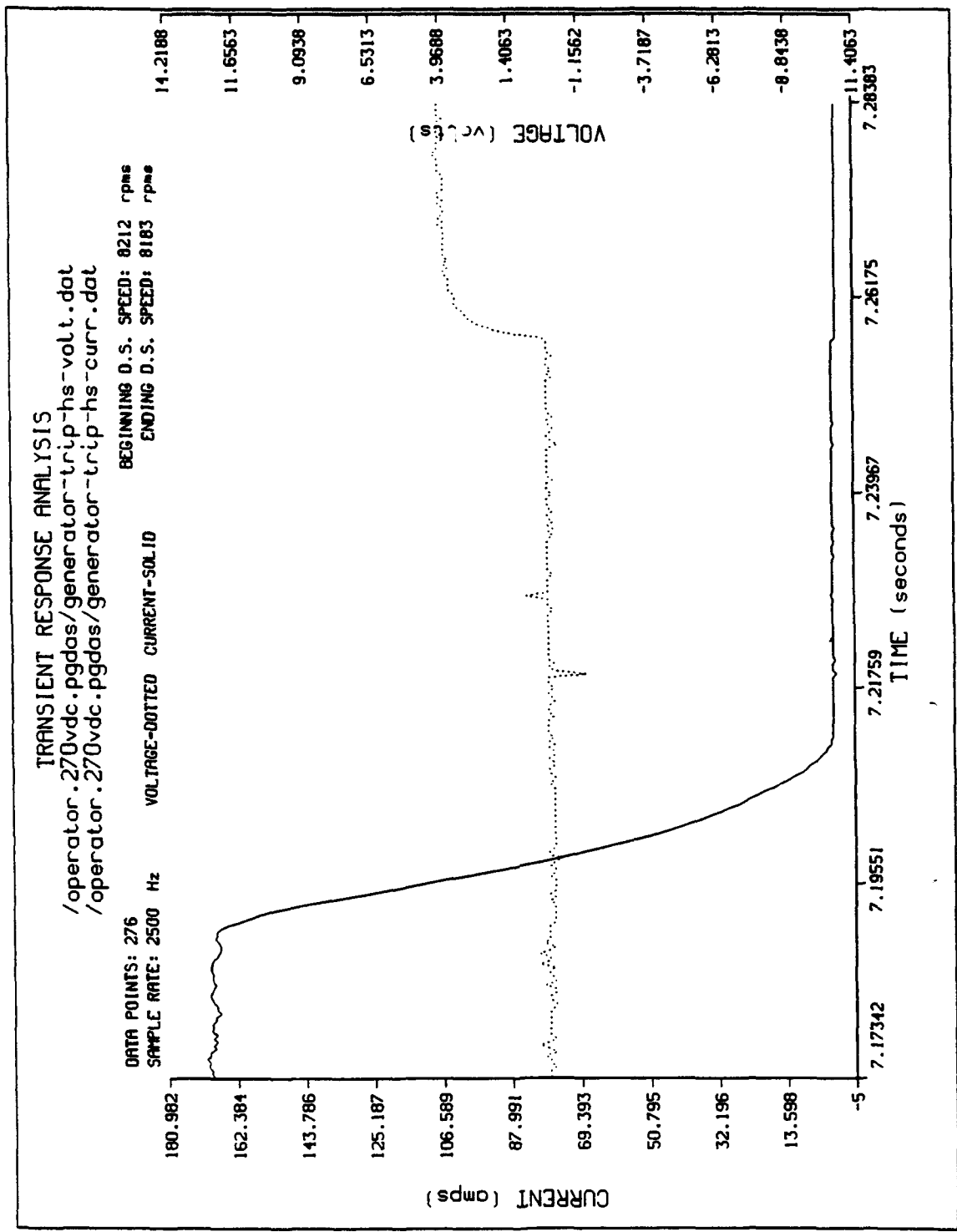

Figure 89: Generator Trip / Fault Clear, 8200 rpm

SECTION 4

CONCLUSIONS

This generator system evaluation successfully accomplished its goals. It demonstrated that the Aircraft Electrical Laboratory (POOC-1) is very capable of providing a thorough evaluation of 270 Vdc generator systems. The evaluation also provided an independent evaluation of the modified AV-8B 270 Vdc 22.5/30 kW generator system for future reference by the Air Force and Industry. It is also concluded that this generator system is an excellent choice for source of primary power for POOC-1's 270 Vdc Testbed.

The modified AV-8B generator system performed satisfactorily during all test sequences. Where appropriate, the results were compared to limits defined in MIL-STD-704E and except for a few transient conditions, the generator met MIL-STD-704E. In the seven transient conditions that the generator exceeded the MIL-STD-704E limits, the generator was well within the limits specified in MIL-STD-704D. The maximum measured ripple peak-to-peak voltage was 3.18 V and the maximum distortion factor measured from 1 Hz to 125 kHz was 0.00291. Both of these worse cases are well within the limits found in MIL-STD-704E. The overload protection circuitry worked as required by limiting fault current to 168 A (slightly greater than a 2 per unit overload) after fault detection and interrupting the fault 5 seconds after fault initiation.

REFERENCES

1. Borger, William U., Joseph P. Walick, Phillip G. Gaberdiel, 1Lt, USAF, and Jere L. Brown, 2Lt, USAF, "A-10 Generator System Performance Test 30/40 KVA Integrated Drive Generator," AFWAL-TR-81-2070, September 1981.
2. Fox, Jeffrey A., and David A. Criminski, "Analysis Procedures Utilizing MIL-STD-704D," UDRI UDR-TR-89-57, July 1989.
3. MIL-STD-704D, Aircraft Electric Power Characteristics, 30 September 1980.
4. MIL-STD-704E, Aircraft Electric Power Characteristics, 1 May 1991.
5. Shannon, Jennifer M., "270 Volt Direct Current Generator Performance Evaluation," NADC-91003-60, December 1990.

APPENDIX A

TEST SEQUENCE DESCRIPTIONS

The actual data files referenced in this appendix are listed in Appendix B.

LOAD APPLICATIONS AND REMOVALS FOR TRANSIENT CHARACTERISTICS:

The purpose of these test sequences is to measure generator system transient responses to various load conditions. These test sequences were also used to measure generator voltage ripple. 20 A, 50 A, 80 A, 100 A, 110 A_LOAD.TR test sequences set generator speed to 4000 Rotations Per Minute (rpm) steady state and collect generator output voltage and current data for 6.6 s as each load is applied for 3 s and removed. After each load removal, the generator speed is set to zero. 20 A, 50 A, 80 A, 100 A, 110 A_LOAD_HS.TR test sequences are identical to 20 A, 50 A, 80 A, 100 A, 110 A_LOAD.TR test sequences except generator speed is set to 8200 rpm for load applications and removals.

OVERLOAD_5MIN.TR sets generator speed to 4000 rpm steady state and applies an 80 A (22.5 kW) steady state load. After the generator recovers from the 80 A transient, generator output voltage and current data is collected for 3.3 s as a 120 A (1.5 per unit) load is applied for 1.65 s and removed. OVERLOAD_5MIN_HS.TR is identical to OVERLOAD_5MIN.TR except generator speed is set to 8200 rpm for the test sequence.

OVERLOAD_5SEC.TR sets generator speed to 4000 rpm steady state and applies an 80 A (22.5 kW) steady state load. After the generator recovers from the 80 A transient, generator output voltage and current data is collected for 3.3 s as a 160 A (2 per unit) load is applied for 1.65 s and removed. OVERLOAD_5SEC_HS.TR is identical to OVERLOAD_5SEC.TR except generator speed is set to 8200 rpm for the test sequence.

ACCELERATE/DECELERATE:

These test sequences monitor generator output voltage and current at rated full load as a function of generator speed. ACCELERATE_500.TR sets generator speed to 4000 rpm. A 110 A (30 kW) load is then applied and the test sequence pauses to allow the generator to recover from the transient. Generator voltage and current data is then collected as generator speed is accelerated from 4000 rpm to 8200 rpm at a rate of 500 rpm/s. After data acquisition is complete, the load is removed and the generator speed is set to zero. ACCELERATE_1000.TR is identical to ACCELERATE_500.TR except that the generator acceleration rate is 1000 Rpm/s.

DECELERATE_500.TR sets generator speed to 8200 rpm. A 110 A (30 kW) load is then applied and the test sequence pauses to allow the generator to recover from the transient. Generator voltage and current data is then collected as generator speed is decelerated from 8200 rpm to 4000 rpm at a rate of 500 rpm/s. After data

acquisition is complete, the load is removed and the generator speed is set to zero. DECELERATE_1000.TR is identical to DECELERATE_500.TR except that the generator deceleration rate is 1000 rpm/s.

DISTORTION:

The distortion test sequences were used to measure the distortion spectrum and calculate the distortion factor (Total Harmonic Distortion) from 10 Hz up to 125 kHz at various generator loads and speeds. 20 A, 50 A, 80 A, 100 A, and 110 A_LOAD.THD test sequences set the generator speed to 4000 rpm and then applied the respective load. After pausing 1 s to allow for generator transient recovery, generator output voltage was collected for 0.13 s at a rate of 250 kHz. After each data acquisition, the load was removed and the generator speed set to zero. 20 A, 50 A, 80 A, 100 A, and 110 A_LOAD_HS.THD test sequences are the same as 20 A, 50 A, 80 A, 100 A, and 110 A_LOAD.THD test sequences except generator speed was set to 8200 rpm. Generator

FAULT CURRENTS:

These test sequences were executed manually. The object of these tests is to collect generator voltage and current data as a short-circuit is manually applied to the generator and then cleared by the generator protection circuitry internal to the generator control unit. Two tests were performed -- one with generator speed set to 4000 rpm and the other with generator speed set to 8200 rpm. Each test had the operator manually set the generator speed to the appropriate value. Once the speed was set, data acquisition was manually initiated followed by the operator applying a short across the generator. Data acquisition continued until after the short was cleared by the generator control unit protection circuitry. After data acquisition was complete, the generator speed was set to zero to reset the generator.

APPENDIX B

TEST EXECUTION LOG

The following is a recording of the actual test procedure used to collect transient response and acceleration/deceleration data on the Westinghouse 270 volt dc generator. The program used to collect data is called PGDAS 270.EXE and is executed on a DEC VAX/VMS Workstation. Once the data was collected, analysis was performed on the data. The results of this analysis is included in another section in this report.

Welcome to VMS V4.7

Username: OPERATOR
Password:

Welcome to VAX/VMS V4.7A

Last interactive login on Friday, 28-AUG-1992 08:39

***** For a complete list of AEL system GLOBAL commands
type>> GLOBAL at the user prompt.

28-AUG-1992 08:42:14

Directory \$DISK2:[OPERATOR]

115VAC.DIR;1	1	17-AUG-1992 10:48
270VDC.DIR;1	1	17-AUG-1992 10:48

Total of 2 files, 2 blocks.

\$ DOWN 270VDC
\$DISK2:[OPERATOR.270VDC]

\$ DOWN PGDAS
\$DISK2:[OPERATOR.270VDC.PGDAS]

The following list contains the transient response test sequence data files which will be executed. These test sequences were created using the menu-driven test sequence creation section of the PGDAS 270 program. They contain the sequence of test commands to execute on the 270 volt DC generator.

Directory \$DISK2:[OPERATOR.270VDC.PGDAS]

100A_LOAD.TR;7	1	25-AUG-1992 13:09
100A_LOAD_HS.TR;7	1	25-AUG-1992 13:10
110A_LOAD.TR;6	1	25-AUG-1992 13:15
110A_LOAD_HS.TR;6	1	25-AUG-1992 13:16
20A_LOAD.TR;7	1	28-AUG-1992 08:06
20A_LOAD_HS.TR;5	1	25-AUG-1992 13:12
50A_LOAD.TR;7	1	25-AUG-1992 13:11
50A_LOAD_HS.TR;7	1	25-AUG-1992 13:12
80A_LOAD.TR;6	1	25-AUG-1992 13:11
80A_LOAD_HS.TR;7	1	25-AUG-1992 13:10
ACCELERATE_1000.TR;4	1	26-AUG-1992 12:58
ACCELERATE_500.TR;5	1	26-AUG-1992 12:55
DecelerATE_1000.TR;11	1	26-AUG-1992 12:53
DecelerATE_500.TR;4	1	26-AUG-1992 12:55
OVERLOAD_5MIN.TR;8	1	25-AUG-1992 13:19
OVERLOAD_5MIN_HS.TR;8	1	25-AUG-1992 13:19
OVERLOAD_5SEC.TR;6	1	25-AUG-1992 13:20
OVERLOAD_5SEC_HS.TR;8	1	25-AUG-1992 13:20

Total of 18 files, 18 blocks.

\$ TYPE 100A_LOAD.TR

```
BEGIN
ACCELERATION
1000
DECELERATION
500
SPEED
4000
DELAY
8.00
FILENAMES
100A_LOAD_volt.dat
100A_LOAD_curr.dat
ACQUIRE
6.6
2
10000
131072
DELAY
1.00
LOADS
100
DELAY
3.00
LOADS
0
DELAY
5.00
SPEED
0
END
STOP
```

\$ TYPE 100A_LOAD_HS.TR

```
BEGIN
ACCELERATION
1000
DECELERATION
500
SPEED
8200
DELAY
13.00
FILENAMES
100A_LOAD_HS_volt.dat
100A_LOAD_HS_curr.dat
ACQUIRE
6.6
2
10000
131072
DELAY
1.00
LOADS
100
DELAY
3.00
LOADS
0
```

DELAY
5.00
SPEED
0
END
STOP

\$ TYPE 110A_LOAD.TR

BEGIN
ACCELERATION
1000
DECELERATION
500
SPEED
4000
DELAY
8.00
FILENAMES
110A_LOAD_volt.dat
110A_LOAD_curr.dat
ACQUIRE
6.6
2
10000
131072
DELAY
1.00
LOADS
110
DELAY
3.00
LOADS
0
DELAY
5.00
SPEED
0
END
STOP

\$ TYPE 110A_LOAD_HS.TR

BEGIN
ACCELERATION
1000
DECELERATION
500
SPEED
8200
DELAY
13.00
FILENAMES
110A_LOAD_HS_volt.dat
110A_LOAD_HS_curr.dat
ACQUIRE
6.6
2
10000
131072
DELAY
1.00
LOADS
110

DELAY
3.00
LOADS
0
DELAY
5.00
SPEED
0
END
STOP

\$ TYPE 20A_LOAD.TR

BEGIN
ACCELERATION
1000
DECELERATION
500
SPEED
4000
DELAY
8.00
FILENAMES
20A_load_volt.dat
20A_load_curr.dat
ACQUIRE
6.6
2
10000
131072
DELAY
1.00
LOADS
20
DELAY
3.00
LOADS
0
DELAY
5.00
SPEED
0
END
STOP

\$ TYPE 20A_LOAD_HS.TR

BEGIN
ACCELERATION
1000
DECELERATION
500
SPEED
8200
DELAY
13.00
FILENAMES
20A_LOAD_HS_volt.dat
20A_LOAD_HS_curr.dat
ACQUIRE
6.6
2
10000
131072

DELAY
1.00
LOADS
20
DELAY
3.00
LOADS
0
DELAY
5.00
SPEED
0
END
STOP

\$ TYPE 50A_LOAD.TR

BEGIN
ACCELERATION
1000
DECELERATION
500
SPEED
4000
DELAY
8.00
FILENAMES
50A_LOAD_volt.dat
50A_LOAD_curr.dat
ACQUIRE
6.6
2
10000
131072
DELAY
1.00
LOADS
50
DELAY
3.00
LOADS
0
DELAY
5.00
SPEED
0
END
STOP

\$ TYPE 50A_LOAD_HS.TR

BEGIN
ACCELERATION
1000
DECELERATION
500
SPEED
8200
DELAY
13.00
FILENAMES
50A_LOAD_HS_volt.dat
50A_LOAD_HS_curr.dat
ACQUIRE

6.6
2
10000
131072
DELAY
1.00
LOADS
50
DELAY
3.00
LOADS
0
DELAY
5.00
SPEED
0
END
STOP

\$ TYPE 80A_LOAD.TR

BEGIN
ACCELERATION
1000
DECELERATION
500
SPEED
4000
DELAY
8.00
FILENAMES
80A_LOAD_volt.dat
80A_LOAD_curr.dat
ACQUIRE
6.6
2
10000
131072
DELAY
1.00
LOADS
80
DELAY
3.00
LOADS
0
DELAY
5.00
SPEED
0
END
STOP

\$ TYPE 80A_LOAD_HS.TR

BEGIN
ACCELERATION
1000
DECELERATION
500
SPEED
8200
DELAY
13.00

```
FILENAMEs
80A_LOAD_HS_volt.dat
80A_LOAD_HS_curr.dat
ACQUIRE
6.6
2
10000
131072
DELAY
1.00
LOADS
80
DELAY
3.00
LOADS
0
DELAY
5.00
SPEED
0
END
STOP
```

```
$ TYPE ACCELERATE_1000.TR
```

```
BEGIN
ACCELERATION
1000
DECELERATION
1000
SPEED
4000
DELAY
8.00
LOADS
110
DELAY
5.00
FILENAMEs
accelerate_1000_volt.dat
accelerate_1000_curr.dat
ACQUIRE
6.6
2
10000
131072
DELAY
0.50
SPEED
8200
DELAY
13.00
LOADS
0
SPEED
0
END
STOP
```

```
$ TYPE ACCELERATE_500.TR
```

```
BEGIN
ACCELERATION
500
```

```
DECELERATION
1000
SPEED
4000
DELAY
12.00
LOADS
110
DELAY
5.00
FILENAMES
accelerate_500_volt.dat
accelerate_500_curr.dat
ACQUIRE
13.11
2
5000
131072
DELAY
0.50
SPEED
8200
DELAY
19.00
LOADS
0
SPEED
0
END
STOP
```

```
$ TYPE Decelerate_1000.TR
```

```
BEGIN
ACCELERATION
1000
DECELERATION
1000
SPEED
8200
DELAY
12.00
LOADS
110
DELAY
5.00
FILENAMES
decelerate_1000_volt.dat
decelerate_1000_curr.dat
ACQUIRE
6.6
2
10000
131072
DELAY
0.50
SPEED
4000
DELAY
13.00
LOADS
0
SPEED
0
```

END
STOP

\$ TYPE Decelerate_500.TR

BEGIN
ACCELERATION
1000
DECELERATION
500
SPEED
8200
DELAY
12.00
LOADS
110
DELAY
5.00
FILENAMES
decelerate_500_volt.dat
decelerate_500_curr.dat
ACQUIRE
13.11
2
5000
131072
DELAY
0.50
SPEED
4000
DELAY
19.00
LOADS
0
SPEED
0
END
STOP

\$ TYPE OVERLOAD_5MIN.TR

BEGIN
ACCELERATION
1000
DECELERATION
500
SPEED
4000
DELAY
8.00
LOADS
80
DELAY
5.00
FILENAMES
overload_5min_volt.dat
overload_5min_curr.dat
ACQUIRE
3.3
2
10000
65536
DELAY
0.75

LOADS
120
DELAY
1.65
LOADS
0
DELAY
2.0
SPEED
0
END
STOP

\$ TYPE OVERLOAD_5MIN_HS.TR

BEGIN
ACCELERATION
1000
DECELERATION
500
SPEED
8200
DELAY
13.00
LOADS
80
DELAY
5.00
FILENAMES
overload_5min_hs_volt.dat
overload_5min_hs_curr.dat
ACQUIRE
3.3
2
10000
65536
DELAY
0.75
LOADS
120
DELAY
1.65
LOADS
0
DELAY
2.0
SPEED
0
END
STOP

\$ TYPE OVERLOAD_5SEC.TR

BEGIN
ACCELERATION
1000
DECELERATION
500
SPEED
4000
DELAY
8.00
LOADS
80

```

DELAY
5.00
FILENAME
overload_5sec_volt.dat
overload_5sec_curr.dat
ACQUIRE
3.3
2
10000
65536
DELAY
0.75
LOADS
160
DELAY
1.65
LOADS
0
DELAY
2.0
SPEED
0
END
STOP

$ TYPE OVERLOAD_5SEC_HS.TR

BEGIN
ACCELERATION
1000
DECELERATION
500
SPEED
8200
DELAY
13.00
LOADS
80
DELAY
5.00
FILENAME
overload_5sec_hs_volt.dat
overload_5sec_hs_curr.dat
ACQUIRE
3.3
2
10000
65536
DELAY
0.75
LOADS
160
DELAY
1.65
LOADS
0
DELAY
2.0
SPEED
0
END
STOP

```

The data acquisition system can be executed from any user account.

Since there are no user accounts on the system, account OPERATOR can be used for all system runs. For specific generator runs, the operator should create a directory for all the data files which will be created during program execution. For general execution of the program the operator should run the program in the subdirectory [OPERATOR.RUN_PGDAS]. To execute the 270 VDC Power Generator Data Acquisition System, enter the command >> PGDAS 270. All data files created by the program will be written to the directory in which the operator is running the program.

Before executing PGDAS_270 the operator should calibrate the voltage dividers and store the new, current calibration ratios in the ratio data file. The volt per amp ratio of the current transformer is also stored in the ratio file. The file is [PGDAS.DATAFILES]VD CT RATIOS_270.DAT, and it can be edited from OPERATOR or PGDAS accounts by entering the command >> RATIO_270.

NOTE: Recording of the actual test sequence execution...

\$ PGDAS_270

```
*****
*
*                                     *
*           W E L C O M E   T O   T H E   A E L           *
*                                     *
*                   2 7 0   V O L T   D C               *
*                                     *
*                   P O W E R   G E N E R A T O R       *
*                                     *
*   D A T A   A C Q U I S I T I O N   S Y S T E M     *
*                                     *
*
*****
```

NOTE: The program will CRASH if executed before BOTH Kinetic Systems Camac Crates have been powered ON

Have BOTH Camac Crates been powered ON (Y/N) [Y] ? <CR>

Open a channel to the CAMAC interface.
Put the serial highway on line.
Clear crate # 1 for inhibit and check for errors.
Clear crate # 2 for inhibit and check for errors.

Version 2.0 ---- 01-Feb-1991
270 VDC POWER GENERATOR DATA ACQUISITION SYSTEM
DATE: 28-AUG-92 TIME: 08:42:39

Use UP and DOWN ARROWS or enter menu LETTER or NUMBER to select the menu choice. Then press <RETURN> to execute that menu choice.

1. (H)alt Program Execution
2. (L)ist/Modify PGDAS Scenario File
3. (T)est Sequence: CREATE or VALIDATE
4. (E)xecute a Test Sequence
5. (C)ollect Generator Data
6. (S)ave a PGDAS Scenario File
7. (R)etrieve a PGDAS Scenario File

Select item #2 -- 2. (L)ist/Modify PGDAS Scenario File

Version 2.0 ---- 01-Feb-1991
270 VDC GENERATOR INFORMATION & CONTROL PARAMETERS
DATE: 28-AUG-92 TIME: 08:42:41

Use UP and DOWN ARROWS or enter menu LETTER or NUMBER
to select the menu choice. Then press <RETURN>
to execute that menu choice.

1. (R)eturn to main menu (PGDAS)
2. (H)earer information
3. (G)enerator information
4. (D)efault Scenario Values Restored

Select item #2 -- 2. (H)earer information

General P G D A S Information

Date: day-month-year
Time: hour:min:sec
Operator: your name
Comments: 1 Line of comments

Change any of the above values (Y/N) [N] ? Y

Date : [day-month-year] ? 28-AUG-92
Time : [hour:min:sec] ? 8:45
Operator: [your name] ? NAIRUS, CRIMINSKI, SEXTON
Comments: [1 Line of comments] ? RECORDING TEST EXECUTION

General P G D A S Information

Date: 28-AUG-92
Time: 8:45
Operator: NAIRUS, CRIMINSKI, SEXTON
Comments: RECORDING TEST EXECUTION

Change any of the above values (Y/N) [N] ? <CR>

Version 2.0 ---- 01-Feb-1991
270 VDC GENERATOR INFORMATION & CONTROL PARAMETERS
DATE: 28-AUG-92 TIME: 08:43:21

Use UP and DOWN ARROWS or enter menu LETTER or NUMBER
to select the menu choice. Then press <RETURN>
to execute that menu choice.

1. (R)eturn to main menu (PGDAS)
2. (H)earer information
3. (G)enerator information
4. (D)efault Scenario Values Restored

Select item #3 -- 3. (G)enerator information

General GENERATOR Information

Drive Stand Number: 3
4022 Transient Digitizer # (ACQUIRE): 1
4022 Transient Digitizer # (RPMS): 2
Maximum Generator Speed: 24600
Generator Speed Increaser: 3
Maximum Drive Stand Speed: 8200
Generator Manufacturer: WESTINGHOUSE
Generator Type: 30KW_110A_270VDC

Generator Serial Number: WRDC-01
Generator Comments:

Change any of the above values (Y/N) [N] ? Y

Drive stand number : [3] ?
4022 Transient Digitizer # (ACQUIRE): [1] ?
4022 Transient Digitizer # (RPMS) : [2] ?
Maximum Generator Speed : [24600] ?
Generator Manufacturer : [WESTINGHOUSE] ?
Generator Type : [30KW 110A 270VDC] ?
Generator Serial Number : [WRDC-01] ?
Generator Comments : [] ? RECORDING TEST EXECUTION

General GENERATOR Information

Drive Stand Number: 3
4022 Transient Digitizer # (ACQUIRE): 1
4022 Transient Digitizer # (RPMS): 2
Maximum Generator Speed: 24600
Generator Speed Increaser: 3
Maximum Drive Stand Speed: 8200
Generator Manufacturer: WESTINGHOUSE
Generator Type: 30KW 110A 270VDC
Generator Serial Number: WRDC-01
Generator Comments: RECORDING TEST EXECUTION

Change any of the above values (Y/N) [N] ? <CR>

Version 2.0 ---- 01-Feb-1991
270 VDC GENERATOR INFORMATION & CONTROL PARAMETERS
DATE: 28-AUG-92 TIME: 08:43:39

Use UP and DOWN ARROWS or enter menu LETTER or NUMBER
to select the menu choice. Then press <RETURN>
to execute that menu choice.

1. (R)eturn to main menu (PGDAS)
2. (H)earer information
3. (G)enerator information
4. (D)efault Scenario Values Restored

Select item #1 -- 1. (R)eturn to main menu (PGDAS)

Version 2.0 ---- 01-Feb-1991
270 VDC POWER GENERATOR DATA ACQUISITION SYSTEM
DATE: 28-AUG-92 TIME: 08:43:42

Use UP and DOWN ARROWS or enter menu LETTER or NUMBER
to select the menu choice. Then press <RETURN>
to execute that menu choice.

1. (H)alt Program Execution
2. (L)ist/Modify PGDAS Scenario File
3. (T)est Sequence: CREATE or VALIDATE
4. (E)xecute a Test Sequence
5. (C)ollect Generator Data
6. (S)ave a PGDAS Scenario File
7. (R)etrieve a PGDAS Scenario File

Select item #4 -- 4. (E)xecute a Test Sequence

Version 2.0 ---- 01-Feb-1991
270 VDC TEST SEQUENCE EXECUTION

DATE: 28-AUG-92 TIME: 09:00:07

Use UP and DOWN ARROWS or enter menu LETTER or NUMBER to select the menu choice. Then press <RETURN> to execute that menu choice.

1. (R)eturn to main menu (PGDAS)
2. (F)ile/Menu Created Test Sequence
3. (P)reset Generator Test Sequences

Select item #2 -- 2. (F)ile/Menu Created Test Sequence

Input filename to execute >> 20A_LOAD.TR

Press <Return> to VALIDATE Test Sequence... <CR>

```
BEGIN
ACCELERATION
1000
DECELERATION
500
SPEED
4000
DELAY
8.0000000000000000
FILENAMEs
20A_load_volt.dat
20A_load_curr.dat
ACQUIRE
6.600000
2
10000
131072
DELAY
1.0000000000000000
LOADS
20
DELAY
3.0000000000000000
LOADS
0
DELAY
5.0000000000000000
SPEED
0
END
```

```
*****
*
*** Successful Test Sequence Validation ***
*
*****
```

Press <Return> to EXECUTE Test Sequence... <CR>

Initial Drive Stand Status

```
COMPUTER control
Currently IDLE
REVERSE Direction
NO Overspeed Fault Conditions
```

>>> Waiting for OPERATOR to MANUALLY START Drive Stand...

>>> Setting Drive Stand SPEED to 4000 rpms
>>> Pause test sequence for 8.00 seconds...
>>> Acquiring 270 VDC generator data for 6.600 seconds...
>>> Pause test sequence for 1.00 seconds...
>>> Setting 20 AMP load
>>> Pause test sequence for 3.00 seconds...
>>> Setting 0 AMP load
>>> Pause test sequence for 5.00 seconds...
>>> Setting Drive Stand SPEED to 0 rpms
>>> Wait 8.0 seconds to decelerate drive stand at (500 rpm/sec) to 0 rpms...

>>> Waiting for OPERATOR to MANUALLY STOP Drive Stand...

Processing Digitizer Channel #1 : DC VOLTAGE...

Processing Digitizer Channel #2 : DC CURRENT...

Press <Return> to terminate this Test Sequence Execution... <CR>

Version 2.0 ---- 01-Feb-1991
270 VDC TEST SEQUENCE EXECUTION
DATE: 28-AUG-92 TIME: 09:10:49

Use UP and DOWN ARROWS or enter menu LETTER or NUMBER
to select the menu choice. Then press <RETURN>
to execute that menu choice.

1. (R)eturn to main menu (PGDAS)
2. (F)ile/Menu Created Test Sequence
3. (P)reset Generator Test Sequences

Select item #2 -- 2. (F)ile/Menu Created Test Sequence

Input filename to execute >> 20A_LOAD_HS.TR

Press <Return> to VALIDATE Test Sequence... <CR>

BEGIN
ACCELERATION
1000
DECELERATION
500
SPEED
8200
DELAY
13.00000000000000
FILENAMES
20A_LOAD_HS_volt.dat
20A_LOAD_HS_curr.dat
ACQUIRE
6.600000
2
10000
131072
DELAY
1.00000000000000
LOADS
20
DELAY
3.00000000000000
LOADS
0
DELAY
5.00000000000000

SPEED
0
END

```
*****  
*  
*** Successful Test Sequence Validation ***  
*  
*****
```

Press <Return> to EXECUTE Test Sequence... <CR>

Initial Drive Stand Status

COMPUTER control
Currently IDLE
REVERSE Direction
NO Overspeed Fault Conditions

>>> Waiting for OPERATOR to MANUALLY START Drive Stand...

>>> Setting Drive Stand SPEED to 8200 rpms
>>> Pause test sequence for 13.00 seconds...
>>> Acquiring 270 VDC generator data for 6.600 seconds...
>>> Pause test sequence for 1.00 seconds...
>>> Setting 20 AMP load
>>> Pause test sequence for 3.00 seconds...
>>> Setting 0 AMP load
>>> Pause test sequence for 5.00 seconds...
>>> Setting Drive Stand SPEED to 0 rpms
>>> Wait 16.4 seconds to decelerate drive stand at (500 rpm/sec) to 0 rpms...

>>> Waiting for OPERATOR to MANUALLY STOP Drive Stand...

Processing Digitizer Channel #1 : DC VOLTAGE...

Processing Digitizer Channel #2 : DC CURRENT...

Press <Return> to terminate this Test Sequence Execution... <CR>

Version 2.0 ---- 01-Feb-1991
270 VDC TEST SEQUENCE EXECUTION
DATE: 28-AUG-92 TIME: 09:14:40

Use UP and DOWN ARROWS or enter menu LETTER or NUMBER
to select the menu choice. Then press <RETURN>
to execute that menu choice.

1. (R)eturn to main menu (PGDAS)
2. (F)ile/Menu Created Test Sequence
3. (P)reset Generator Test Sequences

Select item #2 -- 2. (F)ile/Menu Created Test Sequence

Input filename to execute >> 50A_LOAD.TR

Press <Return> to VALIDATE Test Sequence... <CR>

BEGIN
ACCELERATION
1000
DECELERATION
500
SPEED

```
4000
DELAY
8.0000000000000000
FILENAMES
50A_LOAD_volt.dat
50A_LOAD_curr.dat
ACQUIRE
6.600000
2
10000
131072
DELAY
1.0000000000000000
LOADS
50
DELAY
3.0000000000000000
LOADS
0
DELAY
5.0000000000000000
SPEED
0
END
```

```
*****
*
*** Successful Test Sequence Validation ***
*
*****
```

Press <Return> to EXECUTE Test Sequence... <CR>

Initial Drive Stand Status

COMPUTER control
Currently IDLE
REVERSE Direction
NO Overspeed Fault Conditions

>>> Waiting for OPERATOR to MANUALLY START Drive Stand...

>>> Setting Drive Stand SPEED to 4000 rpms
>>> Pause test sequence for 8.00 seconds...
>>> Acquiring 270 VDC generator data for 6.600 seconds...
>>> Pause test sequence for 1.00 seconds...
>>> Setting 50 AMP load
>>> Pause test sequence for 3.00 seconds...
>>> Setting 0 AMP load
>>> Pause test sequence for 5.00 seconds...
>>> Setting Drive Stand SPEED to 0 rpms
>>> Wait 8.0 seconds to decelerate drive stand at (500 rpm/sec) to 0 rpms...

>>> Waiting for OPERATOR to MANUALLY STOP Drive Stand...

Processing Digitizer Channel #1 : DC VOLTAGE...

Processing Digitizer Channel #2 : DC CURRENT...

Press <Return> to terminate this Test Sequence Execution... <CR>

Version 2.0 ---- 01-Feb-1991
270 VDC TEST SEQUENCE EXECUTION
DATE: 28-AUG-92 TIME: 09:18:25

Use UP and DOWN ARROWS or enter menu LETTER or NUMBER to select the menu choice. Then press <RETURN> to execute that menu choice.

1. (R)eturn to main menu (PGDAS)
2. (F)ile/Menu Created Test Sequence
3. (P)reset Generator Test Sequences

Select item #2 -- 2. (F)ile/Menu Created Test Sequence

Input filename to execute >> 50A_LOAD_HS.TR

Press <Return> to VALIDATE Test Sequence... <CR>

```
BEGIN
ACCELERATION
1000
DECELERATION
500
SPEED
8200
DELAY
13.000000000000000
FILENAMES
50A_LOAD_HS_volt.dat
50A_LOAD_HS_curr.dat
ACQUIRE
6.600000
2
10000
131072
DELAY
1.000000000000000
LOADS
50
DELAY
3.000000000000000
LOADS
0
DELAY
5.000000000000000
SPEED
0
END
```

```
*****
*
*** Successful Test Sequence Validation ***
*
*****
```

Press <Return> to EXECUTE Test Sequence... <CR>

Initial Drive Stand Status

```
COMPUTER control
Currently IDLE
REVERSE Direction
NO Overspeed Fault Conditions
```

>>> Waiting for OPERATOR to MANUALLY START Drive Stand...

>>> Setting Drive Stand SPEED to 8200 rpms

```
>>> Pause test sequence for 13.00 seconds...
>>> Acquiring 270 VDC generator data for 6.600 seconds...
>>> Pause test sequence for 1.00 seconds...
>>> Setting 50 AMP load
>>> Pause test sequence for 3.00 seconds...
>>> Setting 0 AMP load
>>> Pause test sequence for 5.00 seconds...
>>> Setting Drive Stand SPEED to 0 rpms
>>> Wait 16.4 seconds to decelerate drive stand at (500 rpm/sec) to 0 rpms...
```

```
>>> Waiting for OPERATOR to MANUALLY STOP Drive Stand...
```

```
Processing Digitizer Channel #1 : DC VOLTAGE...
```

```
Processing Digitizer Channel #2 : DC CURRENT...
```

```
Press <Return> to terminate this Test Sequence Execution... <CR>
```

```
Version 2.0 ---- 01-Feb-1991
270 VDC TEST SEQUENCE EXECUTION
DATE: 28-AUG-92 TIME: 09:22:24
```

```
Use UP and DOWN ARROWS or enter menu LETTER or NUMBER
to select the menu choice. Then press <RETURN>
to execute that menu choice.
```

- 1. (R)eturn to main menu (PGDAS)
- 2. (F)ile/Menu Created Test Sequence
- 3. (P)reset Generator Test Sequences

```
Select item #2 -- 2. (F)ile/Menu Created Test Sequence
```

```
Input filename to execute >> 80A_LOAD.TR
```

```
Press <Return> to VALIDATE Test Sequence... <CR>
```

```
BEGIN
ACCELERATION
1000
DECELERATION
500
SPEED
4000
DELAY
8.0000000000000000
FILENAMES
80A_LOAD_volt.dat
80A_LOAD_curr.dat
ACQUIRE
6.600000
2
10000
131072
DELAY
1.0000000000000000
LOADS
80
DELAY
3.0000000000000000
LOADS
0
DELAY
5.0000000000000000
SPEED
```

0
END

```
*****  
*  
*** Successful Test Sequence Validation ***  
*  
*****
```

Press <Return> to EXECUTE Test Sequence... <CR>

Initial Drive Stand Status

COMPUTER control
Currently IDLE
REVERSE Direction
NO Overspeed Fault Conditions

>>> Waiting for OPERATOR to MANUALLY START Drive Stand...

>>> Setting Drive Stand SPEED to 4000 rpms
>>> Pause test sequence for 8.00 seconds...
>>> Acquiring 270 VDC generator data for 6.600 seconds...
>>> Pause test sequence for 1.00 seconds...
>>> Setting 80 AMP load
>>> Pause test sequence for 3.00 seconds...
>>> Setting 0 AMP load
>>> Pause test sequence for 5.00 seconds...
>>> Setting Drive Stand SPEED to 0 rpms
>>> Wait 8.0 seconds to decelerate drive stand at (500 rpm/sec) to 0 rpms...

>>> Waiting for OPERATOR to MANUALLY STOP Drive Stand...

Processing Digitizer Channel #1 : DC VOLTAGE...

Processing Digitizer Channel #2 : DC CURRENT...

Press <Return> to terminate this Test Sequence Execution... <CR>

Version 2.0 ---- 01-Feb-1991
270 VDC TEST SEQUENCE EXECUTION
DATE: 28-AUG-92 TIME: 09:25:57

Use UP and DOWN ARROWS or enter menu LETTER or NUMBER
to select the menu choice. Then press <RETURN>
to execute that menu choice.

1. (R)eturn to main menu (PGDAS)
2. (F)ile/Menu Created Test Sequence
3. (P)reset Generator Test Sequences

Select item #2 -- 2. (F)ile/Menu Created Test Sequence

Input filename to execute >> 80A_LOAD_HS.TR

Press <Return> to VALIDATE Test Sequence... <CR>

BEGIN
ACCELERATION
1000
DECELERATION
500
SPEED
8200

DELAY
13.000000000000000
FILENAMES
80A_LOAD_HS_volt.dat
80A_LOAD_HS_curr.dat
ACQUIRE
6.600000
2
10000
131072
DELAY
1.000000000000000
LOADS
80
DELAY
3.000000000000000
LOADS
0
DELAY
5.000000000000000
SPEED
0
END

```
*****  
*  
***   Succesful Test Sequence Validation   ***  
*  
*****
```

Press <Return> to EXECUTE Test Sequence... <CR>

Initial Drive Stand Status

COMPUTER control
Currently IDLE
REVERSE Direction
NO Overspeed Fault Conditions

>>> Waiting for OPERATOR to MANUALLY START Drive Stand...

>>> Setting Drive Stand SPEED to 8200 rpms
>>> Pause test sequence for 13.00 seconds...
>>> Acquiring 270 VDC generator data for 6.600 seconds...
>>> Pause test sequence for 1.00 seconds...
>>> Setting 80 AMP load
>>> Pause test sequence for 3.00 seconds...
>>> Setting 0 AMP load
>>> Pause test sequence for 5.00 seconds...
>>> Setting Drive Stand SPEED to 0 rpms
>>> Wait 16.4 seconds to decelerate drive stand at (500 rpm/sec) to 0 rpms...

>>> Waiting for OPERATOR to MANUALLY STOP Drive Stand...

Processing Digitizer Channel #1 : DC VOLTAGE...

Processing Digitizer Channel #2 : DC CURRENT...

Press <Return> to terminate this Test Sequence Execution... <CR>

Version 2.0 ---- 01-Feb-1991
270 VDC TEST SEQUENCE EXECUTION
DATE: 28-AUG-92 TIME: 09:34:51

Use UP and DOWN ARROWS or enter menu LETTER or NUMBER to select the menu choice. Then press <RETURN> to execute that menu choice.

1. (R)eturn to main menu (PGDAS)
2. (F)ile/Menu Created Test Sequence
3. (P)reset Generator Test Sequences

Select item #2 -- 2. (F)ile/Menu Created Test Sequence

Input filename to execute >> 100A_LOAD.TR

Press <Return> to VALIDATE Test Sequence... <CR>

```
BEGIN
ACCELERATION
1000
DECELERATION
500
SPEED
4000
DELAY
8.000000000000000
FILENAMES
100A_LOAD_volt.dat
100A_LOAD_curr.dat
ACQUIRE
6.600000
2
10000
131072
DELAY
1.000000000000000
LOADS
100
DELAY
3.000000000000000
LOADS
0
DELAY
5.000000000000000
SPEED
0
END
```

```
*****
*
***   Succesful Test Sequence Validation   ***
*
*****
```

Press <Return> to EXECUTE Test Sequence... <CR>

Initial Drive Stand Status

```
COMPUTER control
Currently IDLE
REVERSE Direction
NO Overspeed Fault Conditions
```

>>> Waiting for OPERATOR to MANUALLY START Drive Stand...

```
>>> Setting Drive Stand SPEED to 4000 rpms
>>> Pause test sequence for 8.00 seconds...
```

```
>>> Acquiring 270 VDC generator data for 6.600 seconds...
>>> Pause test sequence for 1.00 seconds...
>>> Setting 100 AMP load
>>> Pause test sequence for 3.00 seconds...
>>> Setting 0 AMP load
>>> Pause test sequence for 5.00 seconds...
>>> Setting Drive Stand SPEED to 0 rpms
>>> Wait 8.0 seconds to decelerate drive stand at (500 rpm/sec) to 0 rpms...

>>> Waiting for OPERATOR to MANUALLY STOP Drive Stand...
```

Processing Digitizer Channel #1 : DC VOLTAGE...

Processing Digitizer Channel #2 : DC CURRENT...

Press <Return> to terminate this Test Sequence Execution... <CR>

Version 2.0 ---- 01-Feb-1991
270 VDC TEST SEQUENCE EXECUTION
DATE: 28-AUG-92 TIME: 09:39:01

Use UP and DOWN ARROWS or enter menu LETTER or NUMBER
to select the menu choice. Then press <RETURN>
to execute that menu choice.

1. (R)eturn to main menu (PGDAS)
2. (F)ile/Menu Created Test Sequence
3. (P)reset Generator Test Sequences

Select item #2 -- 2. (F)ile/Menu Created Test Sequence

Input filename to execute >> 100A_LOAD_HS.TR

Press <Return> to VALIDATE Test Sequence... <CR>

```
BEGIN
ACCELERATION
1000
DECELERATION
500
SPEED
8200
DELAY
13.000000000000000
FILENAMES
100A_LOAD_HS_volt.dat
100A_LOAD_HS_curr.dat
ACQUIRE
6.600000
2
10000
131072
DELAY
1.000000000000000
LOADS
100
DELAY
3.000000000000000
LOADS
0
DELAY
5.000000000000000
SPEED
0
```

END

```
*****  
*  
*** Successful Test Sequence Validation ***  
*  
*****
```

Press <Return> to EXECUTE Test Sequence... <CR>

Initial Drive Stand Status

COMPUTER control
Currently IDLE
REVERSE Direction
NO Overspeed Fault Conditions

>>> Waiting for OPERATOR to MANUALLY START Drive Stand...

>>> Setting Drive Stand SPEED to 8200 rpms
>>> Pause test sequence for 13.00 seconds...
>>> Acquiring 270 VDC generator data for 6.600 seconds...
>>> Pause test sequence for 1.00 seconds...
>>> Setting 100 AMP load
>>> Pause test sequence for 3.00 seconds...
>>> Setting 0 AMP load
>>> Pause test sequence for 5.00 seconds...
>>> Setting Drive Stand SPEED to 0 rpms
>>> Wait 16.4 seconds to decelerate drive stand at (500 rpm/sec) to 0 rpms...

>>> Waiting for OPERATOR to MANUALLY STOP Drive Stand...

Processing Digitizer Channel #1 : DC VOLTAGE...

Processing Digitizer Channel #2 : DC CURRENT...

Press <Return> to terminate this Test Sequence Execution... <CR>

Version 2.0 ---- 01-Feb-1991
270 VDC TEST SEQUENCE EXECUTION
DATE: 28-AUG-92 TIME: 09:42:51

Use UP and DOWN ARROWS or enter menu LETTER or NUMBER
to select the menu choice. Then press <RETURN>
to execute that menu choice.

1. (R)eturn to main menu (PGDAS)
2. (F)ile/Menu Created Test Sequence
3. (P)reset Generator Test Sequences

Select item #2 -- 2. (F)ile/Menu Created Test Sequence

Input filename to execute >> 110A_LOAD.TR

Press <Return> to VALIDATE Test Sequence... <CR>

BEGIN
ACCELERATION
1000
DECELERATION
500
SPEED
4000
DELAY

8.0000000000000000
FILENAMES
110A_LOAD_volt.dat
110A_LOAD_curr.dat
ACQUIRE
6.600000
2
10000
131072
DELAY
1.0000000000000000
LOADS
110
DELAY
3.0000000000000000
LOADS
0
DELAY
5.0000000000000000
SPEED
0
END

```
*****  
*  
***  Succesful Test Sequence Validation  ***  
*  
*****
```

Press <Return> to EXECUTE Test Sequence... <CR>

Initial Drive Stand Status

COMPUTER control
Currently IDLE
REVERSE Direction
NO Overspeed Fault Conditions

>>> Waiting for OPERATOR to MANUALLY START Drive Stand...

>>> Setting Drive Stand SPEED to 4000 rpms
>>> Pause test sequence for 8.00 seconds...
>>> Acquiring 270 VDC generator data for 6.600 seconds...
>>> Pause test sequence for 1.00 seconds...
>>> Setting 110 AMP load
>>> Pause test sequence for 3.00 seconds...
>>> Setting 0 AMP load
>>> Pause test sequence for 5.00 seconds...
>>> Setting Drive Stand SPEED to 0 rpms
>>> Wait 8.0 seconds to decelerate drive stand at (500 rpm/sec) to 0 rpms...

>>> Waiting for OPERATOR to MANUALLY STOP Drive Stand...

Processing Digitizer Channel #1 : DC VOLTAGE...

Processing Digitizer Channel #2 : DC CURRENT...

Press <Return> to terminate this Test Sequence Execution... <CR>

Version 2.0 ---- 01-Feb-1991
270 VDC TEST SEQUENCE EXECUTION
DATE: 28-AUG-92 TIME: 09:47:56

Use UP and DOWN ARROWS or enter menu LETTER or NUMBER

to select the menu choice. Then press <RETURN>
to execute that menu choice.

1. (R)eturn to main menu (PGDAS)
2. (F)ile/Menu Created Test Sequence
3. (P)reset Generator Test Sequences

Select item #2 -- 2. (F)ile/Menu Created Test Sequence

Input filename to execute >> 110A_LOAD_HS.TR

Press <Return> to VALIDATE Test Sequence... <CR>

```
BEGIN
ACCELERATION
1000
DECELERATION
500
SPEED
8200
DELAY
13.000000000000000
FILENAMES
110A_LOAD_HS_volt.dat
110A_LOAD_HS_curr.dat
ACQUIRE
6.600000
2
10000
131072
DELAY
1.000000000000000
LOADS
110
DELAY
3.000000000000000
LOADS
0
DELAY
5.000000000000000
SPEED
0
END
```

```
*****
*
***   Succesful Test Sequence Validation   ***
*
*****
```

Press <Return> to EXECUTE Test Sequence... <CR>

Initial Drive Stand Status

```
COMPUTER control
Currently IDLE
REVERSE Direction
NO Overspeed Fault Conditions
```

>>> Waiting for OPERATOR to MANUALLY START Drive Stand...

>>> Setting Drive Stand SPEED to 8200 rpms

>>> Pause test sequence for 13.00 seconds...

>>> Acquiring 270 VDC generator data for 6.600 seconds...

>>> Pause test sequence for 1.00 seconds...
>>> Setting 110 AMP load
>>> Pause test sequence for 3.00 seconds...
>>> Setting 0 AMP load
>>> Pause test sequence for 5.00 seconds...
>>> Setting Drive Stand SPEED to 0 rpms
>>> Wait 16.4 seconds to decelerate drive stand at (500 rpm/sec) to 0 rpms...

>>> Waiting for OPERATOR to MANUALLY STOP Drive Stand...

Processing Digitizer Channel #1 : DC VOLTAGE...

Processing Digitizer Channel #2 : DC CURRENT...

Press <Return> to terminate this Test Sequence Execution... <CR>

Version 2.0 ---- 01-Feb-1991
270 VDC TEST SEQUENCE EXECUTION
DATE: 28-AUG-92 TIME: 09:56:14

Use UP and DOWN ARROWS or enter menu LETTER or NUMBER
to select the menu choice. Then press <RETURN>
to execute that menu choice.

1. (R)eturn to main menu (PGDAS)
2. (F)ile/Menu Created Test Sequence
3. (P)reset Generator Test Sequences

Select item #2 -- 2. (F)ile/Menu Created Test Sequence

Input filename to execute >> ACCELERATE_500.TR

Press <Return> to VALIDATE Test Sequence... <CR>

BEGIN
ACCELERATION
500
DECELERATION
1000
SPEED
4000
DELAY
12.000000000000000
LOADS
110
DELAY
5.000000000000000
FILENAMES
accelerate_500_volt.dat
accelerate_500_curr.dat
ACQUIRE
13.11000
2
5000
131072
DELAY
0.500000000000000
SPEED
8200
DELAY
19.000000000000000
LOADS
0
SPEED

0
END

```
*****  
*  
***   Succesful Test Sequence Validation   ***  
*  
*****
```

Press <Return> to EXECUTE Test Sequence... <CR>

Initial Drive Stand Status

COMPUTER control
Currently IDLE
REVERSE Direction
NO Overspeed Fault Conditions

>>> Waiting for OPERATOR to MANUALLY START Drive Stand...

>>> Setting Drive Stand SPEED to 4000 rpms
>>> Pause test sequence for 12.00 seconds...
>>> Setting 110 AMP load
>>> Pause test sequence for 5.00 seconds...
>>> Acquiring 270 VDC generator data for 13.110 seconds...
>>> Pause test sequence for 0.50 seconds...
>>> Setting Drive Stand SPEED to 8200 rpms
>>> Pause test sequence for 19.00 seconds...
>>> Setting 0 AMP load
>>> Setting Drive Stand SPEED to 0 rpms
>>> Wait 0.2 seconds to decelerate drivestand at (1000 rpm/sec) to 0 rpms...

>>> Waiting for OPERATOR to MANUALLY STOP Drive Stand...

Processing Digitizer Channel #1 : DC VOLTAGE...

Processing Digitizer Channel #2 : DC CURRENT...

Press <Return> to terminate this Test Sequence Execution... <CR>

Version 2.0 ---- 01-Feb-1991
270 VDC TEST SEQUENCE EXECUTION
DATE: 28-AUG-92 TIME: 10:00:14

Use UP and DOWN ARROWS or enter menu LETTER or NUMBER
to select the menu choice. Then press <RETURN>
to execute that menu choice.

1. (R)eturn to main menu (PGDAS)
2. (F)ile/Menu Created Test Sequence
3. (P)reset Generator Test Sequences

Select item #2 -- 2. (F)ile/Menu Created Test Sequence

Input filename to execute >> ACCELERATE_1000.TR

Press <Return> to VALIDATE Test Sequence... <CR>

BEGIN
ACCELERATION
1000
DECELERATION
1000
SPEED

4000
DELAY
8.000000000000000
LOADS
110
DELAY
5.000000000000000
FILENAMES
accelerate_1000_volt.dat
accelerate_1000_curr.dat
ACQUIRE
6.600000
2
10000
131072
DELAY
0.500000000000000
SPEED
8200
DELAY
13.000000000000000
LOADS
0
SPEED
0
END

```
*****  
*  
***   Succesful Test Sequence Validation   ***  
*  
*****
```

Press <Return> to EXECUTE Test Sequence... <CR>

Initial Drive Stand Status

COMPUTER control
Currently IDLE
REVERSE Direction
NO Overspeed Fault Conditions

>>> Waiting for OPERATOR to MANUALLY START Drive Stand...

>>> Setting Drive Stand SPEED to 4000 rpms
>>> Pause test sequence for 8.00 seconds...
>>> Setting 110 AMP load
>>> Pause test sequence for 5.00 seconds...
>>> Acquiring 270 VDC generator data for 6.600 seconds...
>>> Pause test sequence for 0.50 seconds...
>>> Setting Drive Stand SPEED to 8200 rpms
>>> Pause test sequence for 13.00 seconds...
>>> Setting 0 AMP load
>>> Setting Drive Stand SPEED to 0 rpms
>>> Wait 8.2 seconds to decelerate drivestand at (1000 rpm/sec) to 0 rpms...

>>> Waiting for OPERATOR to MANUALLY STOP Drive Stand...

Processing Digitizer Channel #1 : DC VOLTAGE...

Processing Digitizer Channel #2 : DC CURRENT...

Press <Return> to terminate this Test Sequence Execution... <CR>

Version 2.0 ---- 01-Feb-1991
270 VDC TEST SEQUENCE EXECUTION
DATE: 28-AUG-92 TIME: 10:03:54

Use UP and DOWN ARROWS or enter menu LETTER or NUMBER
to select the menu choice. Then press <RETURN>
to execute that menu choice.

1. (R)eturn to main menu (PGDAS)
2. (F)ile/Menu Created Test Sequence
3. (P)reset Generator Test Sequences

Select item #2 -- 2. (F)ile/Menu Created Test Sequence

Input filename to execute >> Decelerate_500.TR

Press <Return> to VALIDATE Test Sequence... <CR>

```
BEGIN
ACCELERATION
1000
DECELERATION
500
SPEED
8200
DELAY
12.000000000000000
LOADS
110
DELAY
5.000000000000000
FILENAMEs
decelerate_500_volt.dat
decelerate_500_curr.dat
ACQUIRE
13.11000
2
5000
131072
DELAY
0.500000000000000
SPEED
4000
DELAY
19.000000000000000
LOADS
0
SPEED
0
END
```

```
*****
*
*** Successful Test Sequence Validation ***
*
*****
```

Press <Return> to EXECUTE Test Sequence... <CR>

Initial Drive Stand Status

```
COMPUTER control
Currently IDLE
REVERSE Direction
```

NO Overspeed Fault Conditions

>>> Waiting for OPERATOR to MANUALLY START Drive Stand...
>>> Setting Drive Stand SPEED to 8200 rpms
>>> Pause test sequence for 12.00 seconds...
>>> Setting 110 AMP load
>>> Pause test sequence for 5.00 seconds...
>>> Acquiring 270 VDC generator data for 13.110 seconds...
>>> Pause test sequence for 0.50 seconds...
>>> Setting Drive Stand SPEED to 4000 rpms
>>> Pause test sequence for 19.00 seconds...
>>> Setting 0 AMP load
>>> Setting Drive Stand SPEED to 0 rpms
>>> Wait 8.0 seconds to decelerate drive stand at (500 rpm/sec) to 0 rpms...
>>> Waiting for OPERATOR to MANUALLY STOP Drive Stand...

Processing Digitizer Channel #1 : DC VOLTAGE...

Processing Digitizer Channel #2 : DC CURRENT...

Press <Return> to terminate this Test Sequence Execution... <CR>

Version 2.0 ---- 01-Feb-1991
270 VDC TEST SEQUENCE EXECUTION
DATE: 28-AUG-92 TIME: 10:09:52

Use UP and DOWN ARROWS or enter menu LETTER or NUMBER
to select the menu choice. Then press <RETURN>
to execute that menu choice.

1. (R)eturn to main menu (PGDAS)
2. (F)ile/Menu Created Test Sequence
3. (P)reset Generator Test Sequences

Select item #2 -- 2. (F)ile/Menu Created Test Sequence

Input filename to execute >> Decelerate_1000.TR

Press <Return> to VALIDATE Test Sequence... <CR>

BEGIN
ACCELERATION
1000
DECELERATION
1000
SPEED
8200
DELAY
12.000000000000000
LOADS
110
DELAY
5.000000000000000
FILENAMES
decelerate_1000_volt.dat
decelerate_1000_curr.dat
ACQUIRE
6.600000
2
10000
131072
DELAY

0.5000000000000000
SPEED
4000
DELAY
13.000000000000000
LOADS
0
SPEED
0
END

```
*****  
*  
*** Successful Test Sequence Validation ***  
*  
*****
```

Press <Return> to EXECUTE Test Sequence... <CR>

Initial Drive Stand Status

COMPUTER control
Currently IDLE
REVERSE Direction
NO Overspeed Fault Conditions

>>> Waiting for OPERATOR to MANUALLY START Drive Stand...

>>> Setting Drive Stand SPEED to 8200 rpms
>>> Pause test sequence for 12.00 seconds...
>>> Setting 110 AMP load
>>> Pause test sequence for 5.00 seconds...
>>> Acquiring 270 VDC generator data for 6.600 seconds...
>>> Pause test sequence for 0.50 seconds...
>>> Setting Drive Stand SPEED to 4000 rpms
>>> Pause test sequence for 13.00 seconds...
>>> Setting 0 AMP load
>>> Setting Drive Stand SPEED to 0 rpms
>>> Wait 4.0 seconds to decelerate drivestand at (1000 rpm/sec) to 0 rpms...

>>> Waiting for OPERATOR to MANUALLY STOP Drive Stand...

Processing Digitizer Channel #1 : DC VOLTAGE...

Processing Digitizer Channel #2 : DC CURRENT...

Press <Return> to terminate this Test Sequence Execution... <CR>

Version 2.0 ---- 01-Feb-1991
270 VDC TEST SEQUENCE EXECUTION
DATE: 28-AUG-92 TIME: 10:15:13

Use UP and DOWN ARROWS or enter menu LETTER or NUMBER
to select the menu choice. Then press <RETURN>
to execute that menu choice.

1. (R)eturn to main menu (PGDAS)
2. (F)ile/Menu Created Test Sequence
3. (P)reset Generator Test Sequences

Select item #2 -- 2. (F)ile/Menu Created Test Sequence

Input filename to execute >> OVERLOAD_5SEC.TR

Press <Return> to VALIDATE Test Sequence... <CR>

```
BEGIN
ACCELERATION
1000
DECELERATION
500
SPEED
4000
DELAY
8.0000000000000000
LOADS
80
DELAY
5.0000000000000000
FILENAMES
overload_5sec_volt.dat
overload_5sec_curr.dat
ACQUIRE
3.300000
2
10000
65536
DELAY
0.7500000000000000
LOADS
160
DELAY
1.6500000000000000
LOADS
0
DELAY
2.0000000000000000
SPEED
0
END
```

```
*****
*
***   Succesful Test Sequence Validation   ***
*
*****
```

Press <Return> to EXECUTE Test Sequence... <CR>

Initial Drive Stand Status

```
COMPUTER control
Currently IDLE
REVERSE Direction
NO Overspeed Fault Conditions
```

>>> Waiting for OPERATOR to MANUALLY START Drive Stand...

```
>>> Setting Drive Stand SPEED to 4000 rpms
>>> Pause test sequence for 8.00 seconds...
>>> Setting 80 AMP load
>>> Pause test sequence for 5.00 seconds...
>>> Acquiring 270 VDC generator data for 3.300 seconds...
>>> Pause test sequence for 0.75 seconds...
>>> Setting 160 AMP load
>>> Pause test sequence for 1.65 seconds...
>>> Setting 0 AMP load
>>> Pause test sequence for 2.00 seconds...
```

```
>>> Setting Drive Stand SPEED to 0 rpms
>>> Wait 8.0 seconds to decelerate drive stand at (500 rpm/sec) to 0 rpms...
>>> Waiting for OPERATOR to MANUALLY STOP Drive Stand...
Processing Digitizer Channel #1 : DC VOLTAGE...
Processing Digitizer Channel #2 : DC CURRENT...
Press <Return> to terminate this Test Sequence Execution... <CR>
```

```
Version 2.0 ---- 01-Feb-1991
270 VDC TEST SEQUENCE EXECUTION
DATE: 28-AUG-92 TIME: 10:19:02
```

```
Use UP and DOWN ARROWS or enter menu LETTER or NUMBER
to select the menu choice. Then press <RETURN>
to execute that menu choice.
```

1. (R)eturn to main menu (PGDAS)
2. (F)ile/Menu Created Test Sequence
3. (P)reset Generator Test Sequences

```
Select item #2 -- 2. (F)ile/Menu Created Test Sequence
```

```
Input filename to execute >> OVERLOAD_5MIN.TR
```

```
Press <Return> to VALIDATE Test Sequence... <CR>
```

```
BEGIN
ACCELERATION
1000
DECELERATION
500
SPEED
4000
DELAY
8.0000000000000000
LOADS
80
DELAY
5.0000000000000000
FILENAMES
overload_5min_volt.dat
overload_5min_curr.dat
ACQUIRE
3.300000
2
10000
65536
DELAY
0.7500000000000000
LOADS
120
DELAY
1.6500000000000000
LOADS
0
DELAY
2.0000000000000000
SPEED
0
END
```

```
*****
*
*** Successful Test Sequence Validation ***
*
*****
```

Press <Return> to EXECUTE Test Sequence... <CR>

Initial Drive Stand Status

COMPUTER control
Currently IDLE
REVERSE Direction
NO Overspeed Fault Conditions

>>> Waiting for OPERATOR to MANUALLY START Drive Stand...

>>> Setting Drive Stand SPEED to 4000 rpms
>>> Pause test sequence for 8.00 seconds...
>>> Setting 80 AMP load
>>> Pause test sequence for 5.00 seconds...
>>> Acquiring 270 VDC generator data for 3.300 seconds...
>>> Pause test sequence for 0.75 seconds...
>>> Setting 120 AMP load
>>> Pause test sequence for 1.65 seconds...
>>> Setting 0 AMP load
>>> Pause test sequence for 2.00 seconds...
>>> Setting Drive Stand SPEED to 0 rpms
>>> Wait 8.0 seconds to decelerate drive stand at (500 rpm/sec) to 0 rpms...

>>> Waiting for OPERATOR to MANUALLY STOP Drive Stand...

Processing Digitizer Channel #1 : DC VOLTAGE...

Processing Digitizer Channel #2 : DC CURRENT...

Press <Return> to terminate this Test Sequence Execution... <CR>

Version 2.0 ---- 01-Feb-1991
270 VDC TEST SEQUENCE EXECUTION
DATE: 28-AUG-92 TIME: 10:22:53

Use UP and DOWN ARROWS or enter menu LETTER or NUMBER
to select the menu choice. Then press <RETURN>
to execute that menu choice.

1. (R)eturn to main menu (PGDAS)
2. (F)ile/Menu Created Test Sequence
3. (P)reset Generator Test Sequences

Select item #2 -- 2. (F)ile/Menu Created Test Sequence

Input filename to execute >> OVERLOAD_5MIN_HS.TR

Press <Return> to VALIDATE Test Sequence... <CR>

BEGIN
ACCELERATION
1000
DECELERATION
500
SPEED
8200
DELAY

```
13.000000000000000
LOADS
80
DELAY
5.000000000000000
FILENAMES
overload_5min_hs_volt.dat
overload_5min_hs_curr.dat
ACQUIRE
3.300000
2
10000
65536
DELAY
0.750000000000000
LOADS
120
DELAY
1.650000000000000
LOADS
0
DELAY
2.000000000000000
SPEED
0
END
```

```
*****
*
***   Succesful Test Sequence Validation   ***
*
*****
```

Press <Return> to EXECUTE Test Sequence... <CR>

Initial Drive Stand Status

COMPUTER control
Currently IDLE
REVERSE Direction
NO Overspeed Fault Conditions

>>> Waiting for OPERATOR to MANUALLY START Drive Stand...

>>> Setting Drive Stand SPEED to 8200 rpms
>>> Pause test sequence for 13.00 seconds...
>>> Setting 80 AMP load
>>> Pause test sequence for 5.00 seconds...
>>> Acquiring 270 VDC generator data for 3.300 seconds...
>>> Pause test sequence for 0.75 seconds...
>>> Setting 120 AMP load
>>> Pause test sequence for 1.65 seconds...
>>> Setting 0 AMP load
>>> Pause test sequence for 2.00 seconds...
>>> Setting Drive Stand SPEED to 0 rpms
>>> Wait 16.4 seconds to decelerate drive stand at (500 rpm/sec) to 0 rpms...

>>> Waiting for OPERATOR to MANUALLY STOP Drive Stand...

Processing Digitizer Channel #1 : DC VOLTAGE...

Processing Digitizer Channel #2 : DC CURRENT...

Press <Return> to terminate this Test Sequence Execution... <CR>

Version 2.0 ---- 01-Feb-1991
270 VDC TEST SEQUENCE EXECUTION
DATE: 28-AUG-92 TIME: 10:25:47

Use UP and DOWN ARROWS or enter menu LETTER or NUMBER
to select the menu choice. Then press <RETURN>
to execute that menu choice.

1. (R)eturn to main menu (PGDAS)
2. (F)ile/Menu Created Test Sequence
3. (P)reset Generator Test Sequences

Select item #2 -- 2. (F)ile/Menu Created Test Sequence

Input filename to execute >> OVERLOAD_5SEC_HS.TR

Press <Return> to VALIDATE Test Sequence... <CR>

```
BEGIN
ACCELERATION
1000
DECELERATION
500
SPEED
8200
DELAY
13.000000000000000
LOADS
80
DELAY
5.000000000000000
FILENAMES
overload_5sec_hs_volt.dat
overload_5sec_hs_curr.dat
ACQUIRE
3.300000
2
10000
65536
DELAY
0.750000000000000
LOADS
160
DELAY
1.650000000000000
LOADS
0
DELAY
2.000000000000000
SPEED
0
END
```

```
*****
*
*** Successful Test Sequence Validation ***
*
*****
```

Press <Return> to EXECUTE Test Sequence... <CR>

Initial Drive Stand Status

COMPUTER control
Currently IDLE
REVERSE Direction
NO Overspeed Fault Conditions

>>> Waiting for OPERATOR to MANUALLY START Drive Stand...

>>> Setting Drive Stand SPEED to 8200 rpms
>>> Pause test sequence for 13.00 seconds...
>>> Setting 80 AMP load
>>> Pause test sequence for 5.00 seconds...
>>> Acquiring 270 VDC generator data for 3.300 seconds...
>>> Pause test sequence for 0.75 seconds...
>>> Setting 160 AMP load
>>> Pause test sequence for 1.65 seconds...
>>> Setting 0 AMP load
>>> Pause test sequence for 2.00 seconds...
>>> Setting Drive Stand SPEED to 0 rpms
>>> Wait 16.4 seconds to decelerate drive stand at (500 rpm/sec) to 0 rpms...

>>> Waiting for OPERATOR to MANUALLY STOP Drive Stand...

Processing Digitizer Channel #1 : DC VOLTAGE...

Processing Digitizer Channel #2 : DC CURRENT...

Press <Return> to terminate this Test Sequence Execution... <CR>

Version 2.0 ---- 01-Feb-1991
270 VDC TEST SEQUENCE EXECUTION
DATE: 28-AUG-92 TIME: 10:29:21

Use UP and DOWN ARROWS or enter menu LETTER or NUMBER
to select the menu choice. Then press <RETURN>
to execute that menu choice.

1. (R)eturn to main menu (PGDAS)
2. (F)ile/Menu Created Test Sequence
3. (P)reset Generator Test Sequences

Select item #1 -- 1. (R)eturn to main menu (PGDAS)

Version 2.0 ---- 01-Feb-1991
270 VDC POWER GENERATOR DATA ACQUISITION SYSTEM
DATE: 28-AUG-92 TIME: 10:29:29

Use UP and DOWN ARROWS or enter menu LETTER or NUMBER
to select the menu choice. Then press <RETURN>
to execute that menu choice.

1. (H)alt Program Execution
2. (L)ist/Modify PGDAS Scenario File
3. (T)est Sequence: CREATE or VALIDATE
4. (E)xecute a Test Sequence
5. (C)ollect Generator Data
6. (S)ave a PGDAS Scenario File
7. (R)etrieve a PGDAS Scenario File

Select item #1 -- 1. (H)alt Program Execution

-- Normal PGDAS program termination

FORTRAN STOP

NOTE: The following list contains all of the datafiles created during program execution. These files contain the raw voltage and raw current data collected.

\$ DIRECTORY *.DAT

OVERLOAD_5MIN_CURR.DAT;1	1665	28-AUG-1992	10:21
OVERLOAD_5MIN_HS_CURR.DAT;1	1665	28-AUG-1992	10:24
OVERLOAD_5MIN_HS_VOLT.DAT;1	1665	28-AUG-1992	10:24
OVERLOAD_5MIN_VOLT.DAT;1	1665	28-AUG-1992	10:21
OVERLOAD_5SEC_CURR.DAT;1	1665	28-AUG-1992	10:17
OVERLOAD_5SEC_HS_CURR.DAT;1	1665	28-AUG-1992	10:26
OVERLOAD_5SEC_HS_VOLT.DAT;1	1665	28-AUG-1992	10:26
OVERLOAD_5SEC_VOLT.DAT;1	1665	28-AUG-1992	10:17
100A_LOAD_CURR.DAT;1	3329	28-AUG-1992	09:35
100A_LOAD_HS_CURR.DAT;1	3329	28-AUG-1992	09:39
100A_LOAD_HS_VOLT.DAT;2	3329	28-AUG-1992	09:39
100A_LOAD_VOLT.DAT;2	3329	28-AUG-1992	09:35
110A_LOAD_CURR.DAT;1	3329	28-AUG-1992	09:43
110A_LOAD_HS_CURR.DAT;1	3329	28-AUG-1992	09:53
110A_LOAD_HS_VOLT.DAT;1	3329	28-AUG-1992	09:53
110A_LOAD_VOLT.DAT;1	3329	28-AUG-1992	09:43
20A_LOAD_CURR.DAT;1	3329	28-AUG-1992	09:02
20A_LOAD_HS_CURR.DAT;1	3329	28-AUG-1992	09:11
20A_LOAD_HS_VOLT.DAT;1	3329	28-AUG-1992	09:11
20A_LOAD_VOLT.DAT;2	3329	28-AUG-1992	09:02
50A_LOAD_CURR.DAT;1	3329	28-AUG-1992	09:15
50A_LOAD_HS_CURR.DAT;1	3329	28-AUG-1992	09:19
50A_LOAD_HS_VOLT.DAT;1	3329	28-AUG-1992	09:19
50A_LOAD_VOLT.DAT;1	3329	28-AUG-1992	09:15
80A_LOAD_CURR.DAT;1	3329	28-AUG-1992	09:22
80A_LOAD_HS_CURR.DAT;1	3329	28-AUG-1992	09:31
80A_LOAD_HS_VOLT.DAT;2	3329	28-AUG-1992	09:31
80A_LOAD_VOLT.DAT;1	3329	28-AUG-1992	09:22
ACCELERATE_1000_CURR.DAT;1	3329	28-AUG-1992	10:00
ACCELERATE_1000_VOLT.DAT;1	3329	28-AUG-1992	10:00
ACCELERATE_500_CURR.DAT;1	3329	28-AUG-1992	09:56
ACCELERATE_500_VOLT.DAT;1	3329	28-AUG-1992	09:56
DECELERATE_1000_CURR.DAT;1	3329	28-AUG-1992	10:11
DECELERATE_1000_VOLT.DAT;1	3329	28-AUG-1992	10:11
DECELERATE_500_CURR.DAT;1	3329	28-AUG-1992	10:05
DECELERATE_500_VOLT.DAT;1	3329	28-AUG-1992	10:05

Total of 39 files, 106532 blocks.

NOTE: The file testing.sen, created during the program execution is a recording of the basic generator information and operation information for the data collection execution.

\$ TYPE TESTING.SEN

RECORDING TEST EXECUTION
28-AUG-92
8:30
NAIRUS, CRIMINSKI, SEXTON

RECORDING TEST EXECUTION	
3	Drive Stand Number
1	4022 Transient Digitizer # (ACQUIRE)
2	4022 Transient Digitizer # (RPMS)
24600	Maximum Generator Speed
3	Generator Speed Increaser
8200	Maximum Drive Stand Speed
WESTINGHOUSE	

30KW_110A 270VDC
WRDC-01

\$ LOGOUT