

AD-A273 643

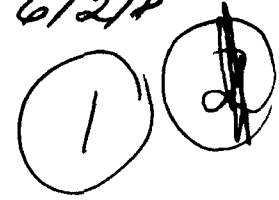

Fultz - 6/21/93



Symposium on Diffusion in Ordered Alloys

ONR Grant N00014-92-J-1921

RECEIVED
JUN 21 1993
Contract Administrator

Final Report 1993

May 31, 1992 through June 1, 1993

S DTIC
ELECTE
DEC 10 1993
A

for

Dr. Steve Fishman
Department of the Navy
Office of Naval Research
800 N. Quincy Street
Arlington, Virginia

from

Brent Fultz
Keck Laboratory of Engineering Materials 138-78
California Institute of Technology
Pasadena, California 91125

This document has been approved
for public release and sale; its
distribution is unlimited.

196
300
93-29392

93 \$22 249

I. The Symposium

The sum of \$ 5,000 from ONR Grant N00014-92-J-1921 was used to help support the symposium "Diffusion in Ordered Alloys and Intermetallic Compounds", organized by Brent Fultz, Robert Cahn, and Dave Gupta for the fall, 1992 meeting of TMS in Chicago. The symposium comprised four sessions, with attendance ranged from 35 at the start to 80 during the final session.

Additional support of the symposium was provided by C. T. Liu of ORNL (\$1,000), and five registration fee waivers were obtained from TMS. The allocation of ONR funds to the invited speakers was as listed in Table I. All ONR funds have now been spent, and final manuscripts have been received from all speakers who were reimbursed.

Table I
Travel and Registration Reimbursement from
ONR Grant N00014-92-J-1921

Dr. Pascal Bellon	601.00
Prof. Robert Cahn	735.00
Prof. Y. Austin Chang	533.80
Dr. Prof. Kurt Lücke	335.00
Prof. Syo Matsumura	698.80
Dr. Prof. Helmut Mehrer	698.80
Prof. Tetsuo Mohri	698.80
Dr. Prof. Gerhard Sauthoff	698.00
Total	<u>5,000.00</u>

Accession For	
NTIS CRA&I	<input checked="" type="checkbox"/>
DTR TAB	<input type="checkbox"/>
Unclassified	<input type="checkbox"/>
Justification	
By _____	
Dist is for /	
Availability Status	
Dist	Availability Status
A-1	Special

II. The Book

DTIC QUALITY INSPECTED 8

All papers were reviewed by at least one referee, and all but one required revisions. A formatting standard (see Appendix A) was enforced for all papers, and all chapters are reasonably uniform in appearance. The manuscript was received by TMS Publications on April 30. Proofs of additional material were received on June 8. The cover design is presented in Appendix B.

The title page contains the statement:

This work relates to the Department of the Navy Grant N00014-92-J-1921 issued by the Office of Naval Research. The United States Government has a royalty-free license throughout the world in all copyrightable material contained herein.

It is expected that the books will be available in July, 1993.
Complementary copies of the book will be sent directly from TMS to:

Scientific Officer Code: 1131N **THREE COPIES**
Dr. Steven G. Fishman
Office of Naval Research
800 North Quincy Street
Arlington, Virginia 22217-5000

Grant Administrator **ONE COPY**
Office of Naval Research
Resident Representative N47092
California Institute of Technology
565 South Wilson Ave.
Pasadena, CA 91106-3212

Defense Technical Information Center **ONE COPY**
Building 5
Cameron Station
Alexandria, Virginia 22314

III. Summary

The Symposium was well-attended, and the book contains some excellent chapters. It is a useful addition to the literature on diffusion in ordered alloys.

**APPENDIX A: FORMAT OF PAPERS FOR
DIFFUSION IN ORDERED ALLOYS**

Formatting Notes

- 0) Use a laserprinter
- 1) 12 point Times font for text and figure captions
- 2) 16 point line spacing (This is slightly less than a spacing of 1.5 lines. If your word processor cannot do this, 1.5 spacing is okay).
- 3) Justify left and right margins

Other details follow the TMS Authors Guide, except 5 below:

- 4) Template typing area is 6 3/8 x 10 inches. Do not bother gluing your printouts on the templates, but please ensure that you have followed the template layouts.
- 5) Indent paragraphs by about 1/4 inch.
(This instruction departs from TMS guidelines)
- 6) Skip a line between paragraphs.
- 7) You format your references any way you like, provided you use the notation [3], or [6-9] in the body of the text.

In my previous letter I suggested that invited papers should be around 12 pages, and contributed ones around 6. Do not, however, cut off your toes to fit the shoe. If you need more length, feel free to take it. Nevertheless, if you have an invited paper that will be longer than 18 pages, or a contributed one longer than 8, please let me know soon.

I would appreciate some help with keywords, so I can prepare an index. Please list them on a separate page.

DIFFUSION IN ORDERED ALLOYS

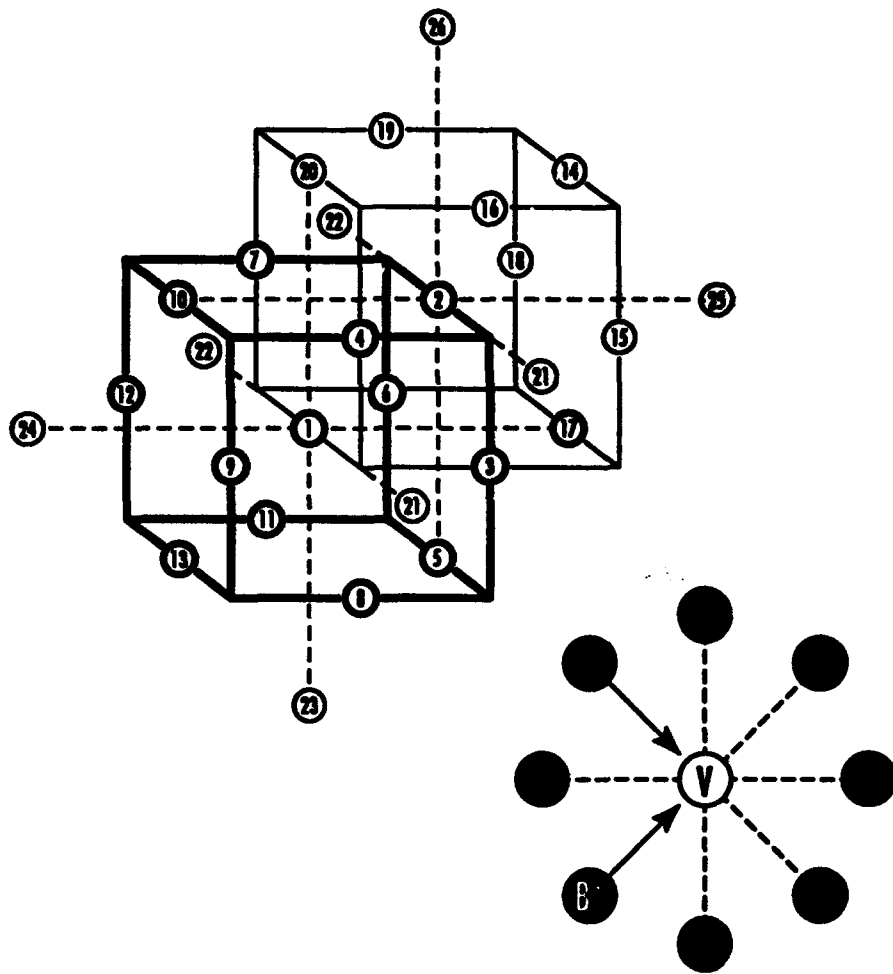

Edited by
B. Fultz, R.W. Cahn, and D. Gupta

DIFFUSION IN ORDERED ALLOYS

TMS
THE METALS SOCIETY OF AMERICA

Fultz • Cahn • Gupta

0-87339-204-3

APPENDIX C: PREFACE TO DIFFUSION IN ORDERED ALLOYS

Preface

Diffusion in ordered alloys and intermetallic compounds has received little attention in recent years, even though it lies at the heart of many fundamental and practical problems. As opposed to diffusion in dilute alloys or solid solutions, atom movements in ordered alloys are affected by the state of order in the material. Conversely, atom movements change the state of order, either locally, leading to large diffusional correlation factors, or globally, leading to order-disorder transformations. Diffusion controls the sequence of compound formation during the intermixing of pure elements, and affects properties such as creep, hydrogen embrittlement, and stability against electromigration. These topics form the scope of this book.

This book originated with the *Symposium on Diffusion in Ordered Alloys and Intermetallic Compounds*, held during the 1992 fall meeting of The Metals, Minerals, and Materials Society (TMS) in Chicago. The goal of this symposium was to bring together scientists having interests in basic and applied problems ranging from diffusional correlation factors, to effects of diffusion on microstructural evolution and on the properties of ordered alloys. The speakers and the topics were selected to match the scope of the nascent book, and the editors and authors worked together to ensure broad coverage without overlap. The editors thank the authors for accommodating the needs of the book, and the selfless referees for helping them to do so.

One of us (B.F.) is indebted to Ms. Pamela Albertson for her help in managing manuscripts and communications with authors. The editors gratefully acknowledge the support for the Symposium provided by the Office of Naval Research (S. Fishman) and the Oak Ridge National Laboratory (C. T. Liu).

Brent Fultz
California Institute of Technology

Robert Cahn
Cambridge University

Dave Gupta
IBM Thomas J. Watson Research Center