

AD-A273 524

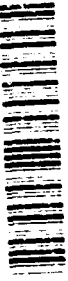

**BASEWIDE
ENGINEERING EVALUATION-
COST ANALYSIS
FOR SOIL VAPOR EXTRACTION**

SITE SPECIFIC DOCUMENT OU C1

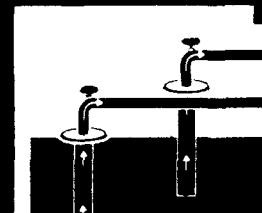
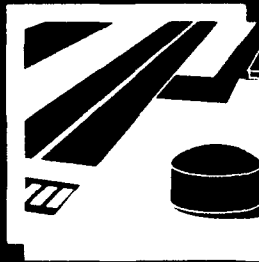
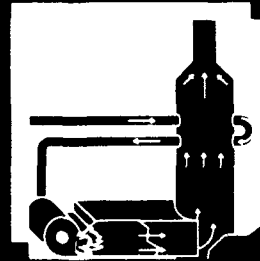

93-28863



30 P/

McClellan Air Force Base

**BASEWIDE
ENGINEERING EVALUATION-
COST ANALYSIS
FOR SOIL VAPOR EXTRACTION**

SITE SPECIFIC DOCUMENT OU C1

Statement A per telecon
Gerry Spyles SM-ALC/EMR-RPM
MC Clellan AFB, CA 95652-1036

NWW 12/8/93

Accession For		
NTIS	CRA&I	<input checked="checked" type="checkbox"/>
DTIC	AB	<input checked="checked" type="checkbox"/>
Other	to add	<input type="checkbox"/>
Date of Report		
Date of Revision		
Date of Distribution		
Date of Review		
Date of Approval		
Date of Release		
Date of Archiving		
Date of Disposal		
Date of Destruction		
Date of Destruction		
A-1		

McClellan Air Force Base

November 1993
Final



TABLE OF CONTENTS

Section 1	Introduction	1
Section 2	Site Characterization	2
	Investigation Results	6
	Interpretation	8
	Site 42 and PRL 68	8
	Site 22	12
Section 3	Justification of SVE Removal Action	15
Section 4	Removal Action Objectives	16
	Scope	16
	ARARs	16
Section 5	Conceptual Design and Cost Estimate	17
	Conceptual Design	17
	Cost Estimate	19
Section 6	Implementation Plan for SVE Removal Action	21
References		22
Glossary		23

LIST OF FIGURES

Figure 2-1	OU C1 Location Maps and Photographs	3
Figure 2-2	Enlarged View of Site 22 Site 42, and PRL 68 Borehole Locations	4
Figure 2-3	OU C1 Cross Section with Geology and TCE Concentrations in Soil Gas and Soil (Numerical Values)	9
Figure 2-4	OU C1 Cross Section with Geology and TCE Concentrations in Soil Gas and Soil, Overlaid with TCE Plume Model	10
Figure 5-1	Location for SVE System Used in Cost Estimate	18
Figure 6-1	Schedule for EE/CA Site Specific Document for OU C1	21
Figure 6-2	Generic Schedule for Implementing an SVE System	22

LIST OF TABLES

Table 2-1	Background Information for Site 22, Site 42, and PRL 68	2
Table 2-2	Summary of OU C1 Soil Investigations	6
Table 2-3	Summary of OU C1 Preliminary VOC Analytical Results and Maximum Reported Concentrations	7
Table 5-1	SVE Cost Estimate for OU C1	20

Section 1 INTRODUCTION

This document supports the use of soil vapor extraction (SVE) as the non-time-critical removal action for selected areas with high levels of volatile organic compound (VOC) contamination in Operable Unit C1 (OU C1). This SVE removal action is part of the initial basewide SVE removal action at McClellan Air Force Base (McAFB). The principal objective of basewide SVE removal actions is to achieve early risk reduction by removing a significant quantity of VOCs from soils in the vadose zone, intercepting an exposure pathway, or preventing additional flux to the groundwater.

This document is a companion to the Basewide Engineering Evaluation-Cost Analysis (EE/CA) General Evaluation Document. The General Evaluation Document provides the long-term framework to standardize and streamline the use of SVE removal actions at McAFB by establishing SVE as the presumptive remedy for McAFB, outlining a site selection methodology for SVE removal actions, and providing a general SVE system configuration and cost estimate.

The site-specific EE/CA for OU C1 focuses only on information necessary to supplement the General Evaluation Document in support of the SVE removal action at OU C1. In particular, this document demonstrates that OU C1 satisfies the criteria listed in the site selection methodology of the General Evaluation Document. Since the General Evaluation Document establishes the case for treating SVE as the presumptive remedy, this document contains no evaluation of alternatives.

Section 2 SITE CHARACTERIZATION

OU C1 is a rectangular area of approximately 23 acres in the southwest central portion of McAFB. As a part of McAFB, it has been associated with waste management and disposal activities throughout most of the base's history, and has been the site of waste oil and solvent storage and burn pits, a refuse incinerator, and building debris storage and burial areas. Open bulk storage and open burning of liquid and solid wastes took place at various times in this area from the mid-1940s to about 1970. OU C1 is currently the location of the McAFB Industrial Waste Treatment Plant (IWTP), as well as a portion of Building 704 (an aircraft maintenance facility), paved parking areas, and an excess clean soil and building rubble storage area.

A total of three confirmed sites (Sites 22, 42, and 69, also identified as LF022, LF042, and DP065, respectively) and two potential release locations (PRL 41 and PRL 68, also identified as LF041 and WP064, respectively) are located in OU C1. Three of these five locations—Site 22, Site 42, and PRL 68—are analyzed in detail to determine their suitability for application of SVE removal actions. These locations were selected on the basis of review of historical information (aerial photos, documents, interviews) and analysis of soil gas and soil samples taken in OU C1. The historical background and current status of these areas are summarized in table 2-1 and described in additional detail below. The locations of the OU C1 sites are shown in figures 2-1 and 2-2.

Site ID	Alternative Designation	Historical Usage	Chemicals of Concern	Current Status
Site 22		Primary disposal and burn debris burial pit (1946-1968); refuse incinerator (1950-1968)	VOCs	Covered with approximately 5 feet of fill: soil/rubble storage area
Site 42	IWTP Area	Three oil storage ponds and possible burn pit (1947-1971) and burn debris pit (1956-1965)	VOCs	Largely covered by the Industrial Waste Treatment Plant blending ponds and aeration basin
PRL 68	IWTP Area	Four oil storage ponds (early 1940's to 1953)	VOCs	Partially covered by the Industrial Waste Treatment Plant

Table 2-1
Background
Information for
Site 22, Site 42,
and PRL 68

Section 2



Site 42/PRL 68 Area
(IWTP Blending Ponds)



Site 22 Area

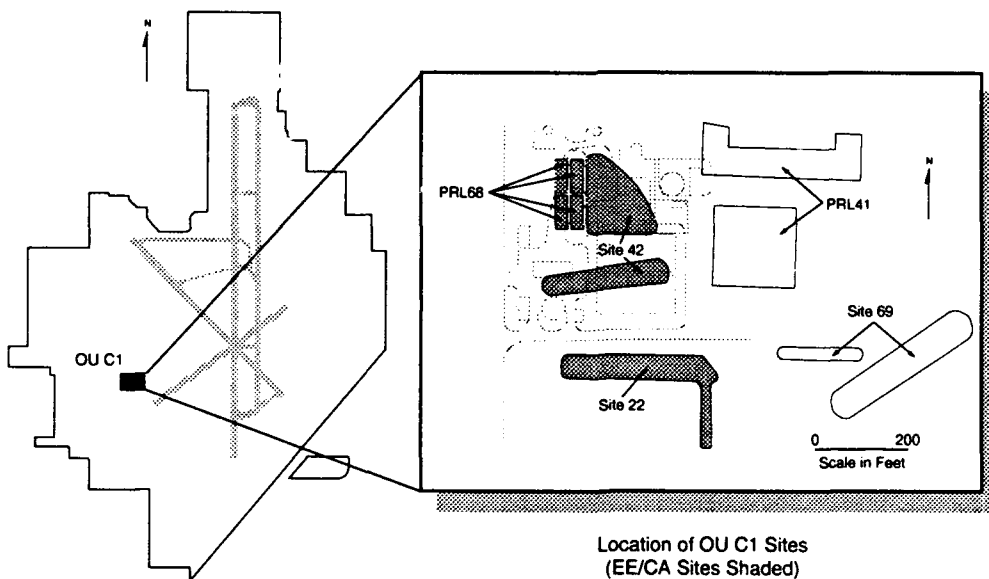

Location of OU C1

Location of OU C1 Sites
(EE/CA Sites Shaded)

Figure 2-1
*OU C1 Location
Maps and
Photographs*

Section 2

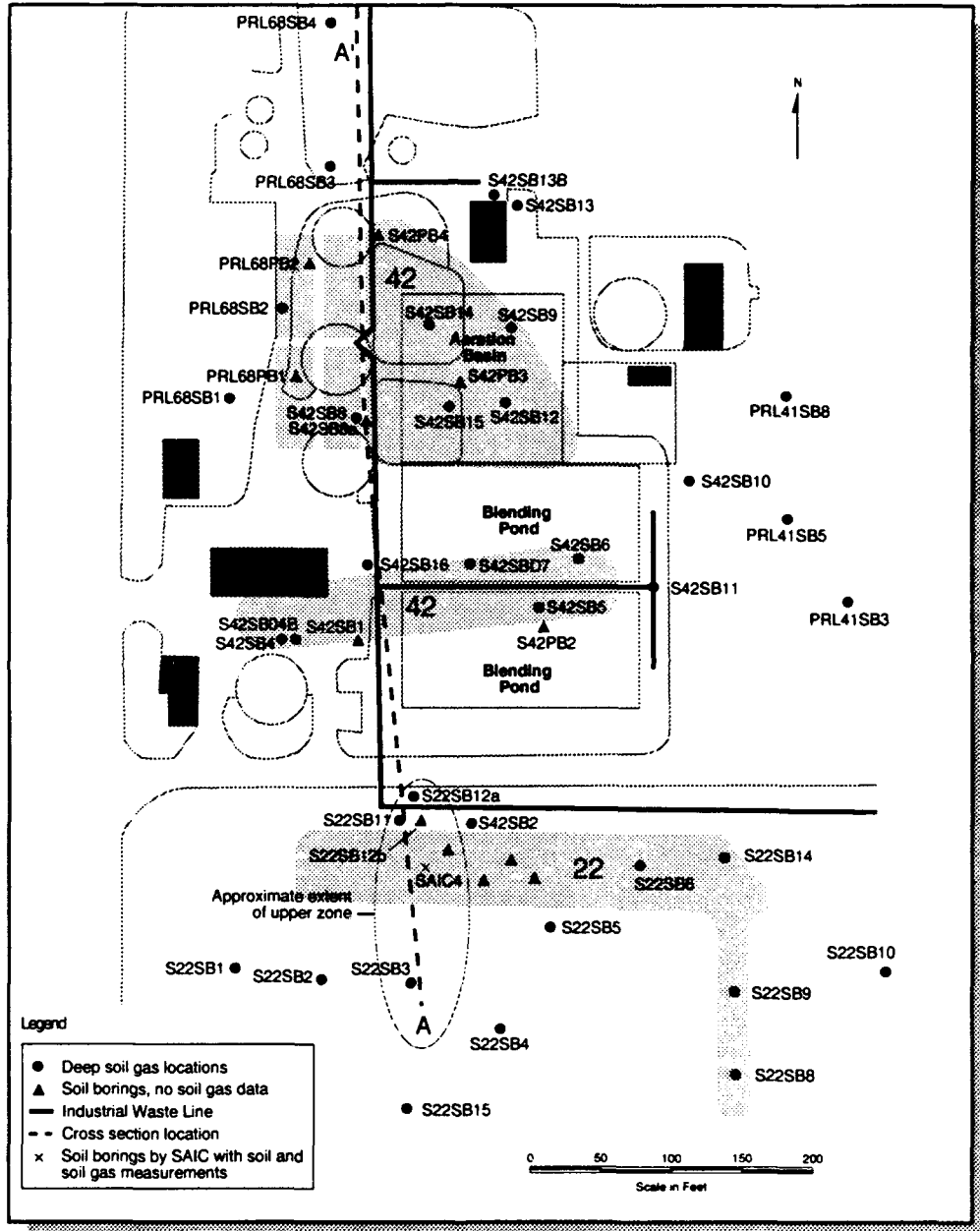

Figure 2-2
 Enlarged View
 of Site 22,
 Site 42, and
 PRL 68
 Borehole
 Locations

Section 2

Site 22 is an L-shaped area in the southwest part of OU C1, with the main portion measuring 50 feet wide by 325 feet long. The smaller portion of the site extends approximately 100 feet south from the eastern end of the main pit area. Historical records indicate that the site was the location of a large solid waste burn pit and, later, of a sheet-metal "teepee" burner-type refuse incinerator. The burn pit was first used in 1946 and continued in use until the 1950s when the incinerator was put into operation (Jacobs Engineering, 1992a). Ash and residue from the incinerator were then disposed of in the original burn pit. Records also indicate that substantial quantities of trichloroethene (TCE) and other spent solvents from base operations were burned at Site 22 (Radian, 1989a). The burial pit and incinerator remained in use until they were closed in 1968; since that time, the area over the site has been used for storage of excess soil and building rubble. The industrial wastewater line (IWL), which transports industrial waste from elsewhere on the base to the IWTP, also crosses a portion of Site 22.

Site 42 consists of two separate areas directly north of Site 22. The northern portion of Site 42 is triangular in shape, measuring about 150 to 175 feet on each side. Between 1946 and about 1974, ponds constructed in the northern portion of Site 42 reportedly held waste solvents and "oil burning sludge" (Radian, 1989b). The northern portion of Site 42 may also have been used as a burn pit/fire training area (CH2M Hill, 1992a). By 1974, the IWTP was fully constructed over this entire area, with an aeration basin located over the original location of the triangular pond (Radian, 1989b). The aeration basin were removed from service in 1987, but remains in place.

The southern portion of Site 42 is the former location of an oblong pit measuring about 275 feet by 40 feet; it was used primarily for burial of burn debris removed from the Site 22 burn pit (Radian, 1989b). The oblong pit also lies beneath a portion of the IWTP and the IWTP blending ponds (steel-reinforced concrete floor and Gunnite side walls) that were installed in 1974 and used until 1987.

PRL 68 is immediately west of the northern portion of Site 42 and consists of four small rectangular areas, each corresponding to a former pit location and measuring about 75 feet long by 25 feet wide. These four pits are thought to have been used for waste oil storage, although their exact history is unknown (Jacobs Engineering, 1992b). This area was in use from the mid-1940s to 1953. PRL 68 also lies beneath the IWTP.

Section 2

Investigation Results

Investigation of soil contamination at OU C1 dates from 1986 when the area was surveyed by McLaren Environmental Engineering. Additional investigations were conducted by McAFB in 1988, by CH2M Hill in 1991, and by Jacobs Engineering in 1991, 1992, and 1993. Table 2-2 summarizes these investigations.

Year	Designation	Number of Borings	Types of Information	Notes
1985	Walker	20	PID soil gas, soil VOC, geologic logs	Sites 22 and 42 appear to show vertical and lateral migration, thought to be contributing to groundwater contamination
1958, 1971-1973	EM Compliance	13	Soil VOC	Site 42 IWTP excavation area, soil samples
1991, 1992	CH2M Hill/SAIC	5	Soil gas, soil VOC	Site 22, 6 soil gas samples
1992, 1993	Jacobs	21	Soil gas, soil VOC, geologic logs	Sites 42 and 68, 16 with soil gas measurements
1992, 1993	Jacobs	18	Soil gas, soil VOC, geologic logs	Site 22, 13 with soil gas measurements

Table 2-2
Summary of
OU C1 Soil
Investigations

Recent investigations have focused on obtaining soil, soil gas, and geologic information in and around each of the confirmed sites and potential release locations in OU C1. Analysis of soil gas data indicates that Site 42 and PRL 68 have the most significant VOC contamination. Soil gas and historical soil data indicate that Site 22 should be examined to determine if it contains a VOC spreading center. Since soil gas VOC concentrations generally are low at PRL 41 and Site 69, these two areas have been dropped as candidates for an SVE removal action. The remainder of this document focuses on the western half of OU C1, including Site 22, Site 42, and PRL 68.

Soil gas samples from recent investigations have been analyzed quantitatively in an off-base laboratory using gas chromatography with photoionization and electron capture detectors. The samples were analyzed for the 15 VOC analytes listed in table 2-3, and all analytes except carbon tetrachloride (CTCL)

Section 2

were commonly detected (that is, present in more than 10 percent of analyzed samples). In addition, as many as 10 analytes identified as "unknowns" are frequently reported in the preliminary data, with maximum concentrations up to 3,400 ppm. In some samples, unknowns constitute more than 50 percent of the total VOC concentration reported. All soil gas data are considered preliminary and are awaiting validation.

Groundwater samples from monitor wells located downgradient from Site 22, Site 42, and PRL 68 are contaminated with compounds also observed in soil gas at these sites. Few monitor wells exist in the B and C zones, but contamination is reported from all three aquifer zones. The A-zone aquifer is most contaminated. Several groundwater extraction wells have been installed to pump water for treatment from the A and B zones. The nearest upgradient well is more than 500 feet north of PRL 68. It is completed in the A zone and has been sampled only once since 1986. The water contained detectable concentrations of DCA11, DCE11, PCE, and TCA111. One or more sites in OU C1 are suspected of contributing VOCs to the groundwater contamination observed in this area of the base.

Analyte	Maximum Concentration (ppmv)
BZ	92
BZME	120
CTCL	2.8
DCE11	15,000
DCE12C	21,000
DCE12T	88
FC113	12
FC12	1.2
PCE	32
TCA111	42
TCE	6,600
TCLME	23
VC	3,800
XYLMP	80
XYLO	49

Table 2-3
*Summary of
 OU C1
 Preliminary
 VOC Analytical
 Results and
 Maximum
 Reported
 Concentrations*

Section 2

Interpretation

The data are sufficient to permit construction of geologic cross sections containing soil and soil gas concentration data for Site 22, Site 42, and PRL 68; one cross section is shown in figures 2-3 and 2-4. This cross section—marked AA' on figure 2-2—spans a distance of nearly 700 feet. The interpretation of geologic data is limited due to the preliminary nature of all data. The soils underneath Site 22 appear to be more sandy than the soils underneath Site 42 and PRL 68, where silts appear to be the dominant soil type (figure 2-3).

The interpretation of the soil and soil gas data follows. In this analysis, the focus is on a single contaminant—TCE. Due to the preliminary nature of the data, the analysis was not extended to include other compounds. TCE is the most commonly detected compound, and it is found in significant quantities in some locations in OU C1.

Site 42 and PRL 68

The former ponds in PRL 68 have been combined with the ponds in the triangular portion of Site 42 for the purpose of this evaluation. This treatment of the ponds in Site 42 and PRL 68, hereafter referred to as 42/68, was motivated by the following considerations: they are adjoining sites; they are thought to have a common history; the VOC contamination found underneath both areas is most likely related to a common source or sources; and it is likely that both sites can be remediated at the same time. The ponds in the 42/68 area are considered potential sources, along with the IWTP and the IWL. Contamination from separate sources in this area may not be distinguishable.

Soil gas data are available from twenty deep boreholes within or near the 42/68 area. Four boreholes have been completed within the aeration basin, which is located directly over two former disposal pits and a triangular disposal pit. High TCE concentrations were reported over significant intervals for two borings (S42SB14 and S42SB15) located inside and along the western boundary of the aeration basin and within the outlines of the original disposal pits. In S42SB14, TCE concentrations in soil gas average about 6,000 ppmv between 27 to 50 feet below ground; in S42SB15, the highest continuous average concentration is about 1,500 ppmv between 50 and 90 feet below ground. Boring PRL68SB2 also contains TCE concentrations of about 1,500 ppmv from 60 to 90 feet below ground. These borings indicate that a core zone of contamination is located in the general area of the aeration basin and old disposal pits.

Section 2

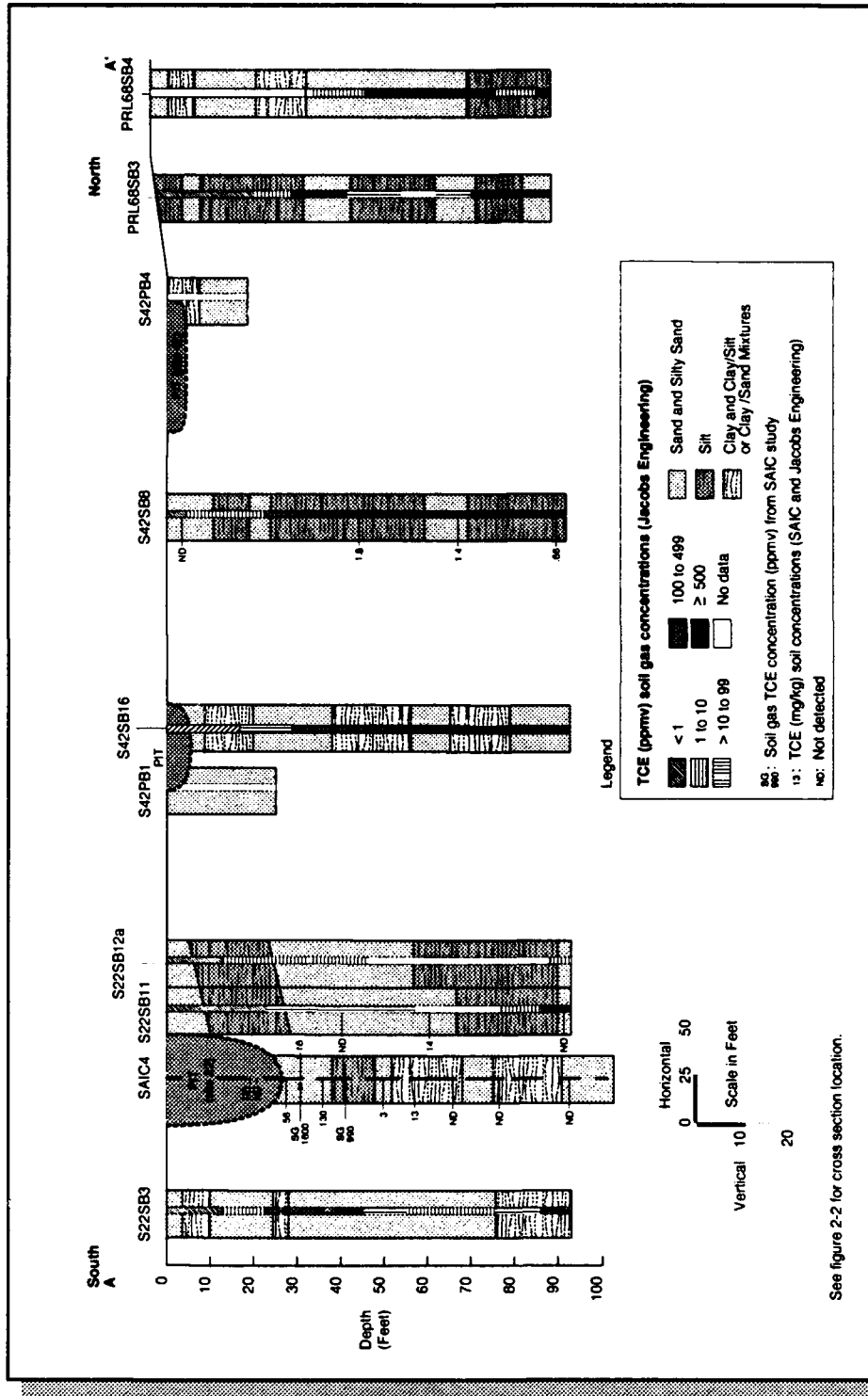
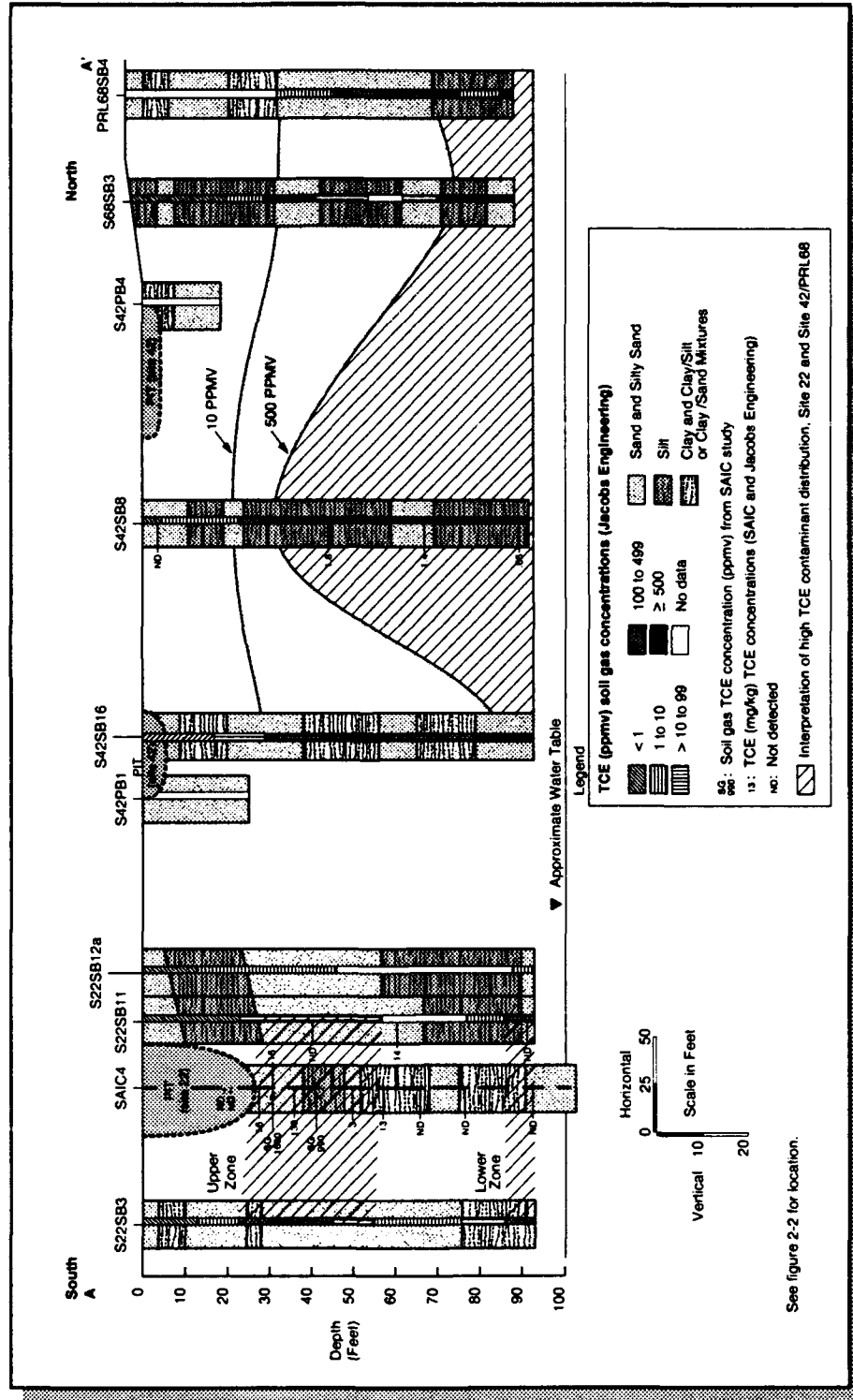

Figure 2-3
 OU C1 Cross Section
 with Geology and
 TCE Concentrations
 in Soil Gas and Soil
 (Numerical Values)

Section 2



Section 2

TCE concentrations in other borings are lower. Borings S42SB9 and S42SB12 inside the aeration basin and borings S42SB5, S42SB7, and S42SB13 have intermediate TCE concentrations. Data from these borings indicate that the plume concentrations are decreasing rapidly to the northeast, east, and south.

TCE concentrations greater than 500 ppmv have been observed in two boreholes to the north of the 42/68 area at depths greater than 70 feet below ground (PRL68SB3 and PRL68SB4). This same pattern also holds for two boreholes to the south (S42SB4 and S42SB16), where the highest concentrations of TCE are at lower depths.

Figure 2-4 shows a TCE plume extending from the core zone under the aeration basin in the north-south direction as an explanation for the pattern of contamination observed near the edges of the plume. For the peripheral borings (PRL68SB3, PRL68SB4, S42SB4, and S42SB16), the principal dispersion mechanism may be related to the movement of contaminated groundwater in the recent past or to vapor dispersion above the capillary fringe of the water table.

TCE concentrations in remaining borings help define the edge of the plume originating near the aeration basin. Borings S42SB10, S42SB11, PRL41SB3, PRL41SB5, and PRL41SB8 are located near the southeastern boundary of the TCE plume, as indicated by low TCE concentrations measured at all depths. Boring PRL68SB1 is near the western boundary of the plume.

The distribution of contaminants in borings S42SB5, S42SB6, S42SB7, and S42SB11 differs significantly from that in most other borings in the 42/68 area. In addition to the commonly observed chlorinated VOCs, samples from these borings contain toluene and xylenes over most of the depths investigated. The maximum concentration reported is 120 ppmv for toluenes and 64 ppmv for total xylenes. Since these borings are located near the eastern section of the oblong pit shown in figure 2-2, it is possible that fuel products could have been deposited in the oblong pit in the past.

In summary, there appears to be a core zone of roughly circular shape centered approximately under the western portion of the triangular pond in Site 42 and the PRL 68 ponds. The core zone is surrounded by a larger zone of less concentrated contamination elongated in the north-south direction at depths greater than 80 feet below ground. The largest dimensions of the plume are estimated to be 200 feet east to west and 800 feet north to south. Although meaningful contaminant mass estimates cannot be made with these preliminary data, available information indicates that a significant mass of VOCs is present in the 42/68 area. Additional borings are planned to complete the definition of the plume to the north and west.

Section 2

Groundwater concentrations of TCE in excess of 10,000 to 20,000 µg/L have been observed in at least one monitor well approximately 350 feet south of the vadose zone contamination in the 42/68 area. The contamination at Site 42 and PRL 68 may contribute, at least in part, to the observed high TCE concentrations in groundwater.

Based on observed concentrations of VOCs in the vadose zone, and the possible connection with existing groundwater contamination, the 42/68 area is recommended for an EE/CA removal action.

While additional boreholes may be drilled as part of the continuing remedial investigation, the oblong pit in Site 42 is not recommended as a separate candidate for a removal action at this time.

Site 22

At Site 22, soil gas data were available from 14 boreholes. The distribution of VOCs in soil gas at Site 22 appears more complex than at other sites modeled to date. While there is an area of highly-contaminated soil near the western end of Site 22, it does not appear to be a significant core zone, nor does it appear to have spread far. Other data, indicating some widely dispersed TCE contamination at moderate concentrations, suggest that there might be two zones of contamination: an upper zone of elevated TCE, separated by tens of feet of low TCE concentrations from a lower zone of elevated TCE near the groundwater table. The cross section shown in figure 2-4 illustrates this pattern for four boreholes from Site 22 (S22SB3, SAIC4, S22SB11, and S22SB12a) near the western end of the trench.

Sources of Contamination. Soil samples collected from and near borehole SAIC4 have some of the highest reported TCE concentrations in soils at the base. Moreover, two soil gas samples collected in a borehole collocated with SAIC4 contained relatively high TCE concentrations—990 and 1600 ppmv (SAIC, 1991; CH2M Hill, 1992). These data point to a TCE source near the SAIC4 location, but they do not indicate the presence a significant source volume at this location.

Soil gas TCE concentrations are available from two boreholes within 100 feet of SAIC4 (S22SB11 and S22SB12a). These concentrations are in the 10–100 ppmv range, rather than the high 100s to 1000 ppmv that would be expected in boreholes close to a significant source volume of TCE. The absence of high VOC soil gas concentrations in the vicinity of SAIC4 suggests the absence of a significant source volume. Soil sampling in SAIC4 also indicates that there is no TCE at depths 60 feet or more below ground. Together, these observations lead to the conclusion that

Section 2

the contamination in and around SAIC4 is a localized, small volume of high-concentration contamination, with limited dispersion in both horizontal and vertical directions.

The eastern portion of Site 22 is a trench where the former teepee burner was used to incinerate refuse, oil, and solvent wastes prior to 1963. Three boreholes from this area (S22SB8, S22SB9, and S22SB14) contained relatively low TCE concentrations (maximum 18 to 100 ppmv). The concentration profiles and the magnitude of the concentrations reported indicate that there is no significant spreading center near this portion of Site 22.

Upper Zone Contamination. Soil gas data from the boreholes along the cross section through Site 22 indicate that an upper zone of TCE contamination exists at depths ranging from about 20 to 75 feet below ground. Soil sampling at SAIC4 reinforces this hypothesis since the highest concentration of TCE in soils was observed at depths to about 60 feet, well within the upper soil gas zone. The thickness of this upper zone varies from about 20 feet to about 55 feet. The average soil gas concentrations within the zone vary by as much as one order of magnitude between boreholes.

An upper zone of contamination is not found in all the Site 22 boreholes. Boreholes S22SB2, S22SB4, S22SB5, and S22SB15 did not have elevated concentrations of TCE in soil gas above 40 feet below ground, thus defining the extent of the upper zone as shown in figure 2-2.

Lower Zone Contamination. A lower zone of elevated TCE is observed near the groundwater table in nearly all the Site 22 boreholes. The highest soil gas TCE concentrations at depths greater than 80 feet below ground occur in four boreholes near the western end of Site 22 (shown on the left side of figure 2-4). This is the same area where TCE concentrations in groundwater exceed 10,000 to 20,000 µg/L. The soil gas data suggest that the lower zone of contamination is related to a "smear zone" where contaminated groundwater has been withdrawn as a result of pumping, as well as degassing of contaminated groundwater beneath OU C1. This seems to be supported further by two soil gas samples (southwest of S22SB1 and S22SB2) collected near the water table as part of the Steam Injection/Vapor Extraction characterization in the western portion of Site 22 (CH2M Hill, 1993). These two boreholes also contain TCE soil gas concentrations greater than 300 ppmv.

A similar pattern of lower-zone contamination occurs in other boreholes, four in the eastern portion of Site 22 (S22SB8, S22SB9, S22SB10, and S22SB14) and one to the south of Site 22 (S22SB15). In general, the eastern portion of the lower zone of contamination contains lower concentrations (less than 50 ppmv TCE at 90 feet below ground) than the western portion (greater than 100 ppmv).

Section 2

Conclusion for Site 22. The total mass of contained TCE in soils at Site 22, based on equilibrium calculations using soil gas data, is small. Less than 200 pounds of TCE is expected in a volume about 60 feet thick, covering an area of a little more than 36,000 square feet (the area circumscribed by existing boreholes). An average unweighted TCE concentration of 42 ppmv in soil gas was applied to the volume, and conservative assumptions about soil type and other variables were used to obtain a maximum estimate of mass.

Therefore, an EE/CA removal action will not be initiated at Site 22 at this time because of the small quantity of contaminant mass. It is possible, however, that SVE operations will be initiated as part of a basewide remedial action for the vadose zone or groundwater.

Section 3

JUSTIFICATION OF SVE REMOVAL ACTION

As discussed in the General Evaluation Document, justification of a removal action using SVE as the presumptive remedy depends upon a two-step evaluation using site-specific information: an SVE feasibility evaluation and a removal action evaluation. As discussed below, the evaluation of the 42/68 area in OU C1 justifies it as an SVE removal action.

The SVE feasibility evaluation considers three criteria: contaminant volatility, air permeability in soil, and depth of contamination. At OU C1, the primary contaminants are TCE and vinyl chloride, both of which meet the volatility criteria. Soils at OU C1 are similar to soils at OU B and OU D. Air permeability tests from OU B and OU D indicate that the soil air permeability ranges from 20 to 250 darcies, and hence well above criterion of at least 10^{-1} darcies. Finally, the depth of VOC contamination in the vadose zone, as demonstrated by soil gas measurements, is from 20 to 75 feet below ground, thus meeting the depth criterion of at least five feet.

Groundwater underneath OU C1 is highly contaminated, with TCE exceeding 20,000 $\mu\text{g/L}$. Sites within OU C1 are likely to be significant sources of this groundwater contamination "hot spot." Although the remedial investigation for OU C1 has not yet been completed, available information indicates that a spreading center in the 42/68 area has reached the groundwater. Given that it is a source for groundwater contamination, this spreading in OU C1 warrants a non-time-critical removal action to prevent additional release of contaminants to groundwater. It is possible that additional significant sources of VOC contamination will be identified with the completion of the remaining investigation efforts, and additional removal actions may be identified later.

Section 4

REMOVAL ACTION OBJECTIVES

Scope

The initial removal action is aimed at removing a significant amount of VOCs from the 42/68 area. The removal action scope will be expanded if additional sampling indicates that this spreading center extends farther than currently anticipated or if the continuing remedial investigation efforts identify additional spreading centers in OU C1.

ARARs

Chemical-specific ARARs: As identified in the General Evaluation Document

Action-specific ARARs: As identified in the General Evaluation Document

Location-specific ARARs: None

Section 5

CONCEPTUAL DESIGN AND COST ESTIMATE

Conceptual Design

The initial design is focused on removing the spreading center in the 42/68 area. There is a core zone of roughly circular shape centered approximately under the western portion of the triangular pond in Site 42 and the PRL 68 ponds. A soil gas plume emanating from this spreading center is elongated in the north-south direction at depths greater than 80 feet below ground.

Seven characterization borings already have been converted to extraction wells—S42SB12 and S42SB14 (screened from 25 to 65 feet below ground); S42SB7 (screened from 50 to 90 feet); S42SB9 and PRL68SB2 (screened from 55 to 90 feet); and PRL68SB4 (screened from 65 to 95 feet). With the exception of PRL68SB4, these extraction wells are concentrated in the area of the former pond locations.

These seven converted boreholes will be used in the initial removal action, as illustrated in figure 5-1. Additional boreholes have been proposed to define the northern and western extent of the plume; depending on the data, they also could be converted to extraction wells and incorporated into the final design.

With the system outlined in figure 5-1, the extraction wells are separated by distances of about 100 to 150 feet, implying that volumes around the wells start to overlap each other at radii of about 50 to 75 feet from the wells. Since the radius of influence should be greater than 50 to 75 feet, the soil volume under the aeration basin and at the western perimeter should be effectively remediated by this system.

If the additional sampling in OU C1 detects other soil gas plumes, boreholes at the sources of these plumes can be converted to extraction wells and added to the SVE system. If more than two wells are added to the system, an additional air-water separator and one or two additional vacuum blowers will be required. Soil gas sampling conducted in the near future should indicate whether expansion of the initial SVE system is necessary.

Section 5

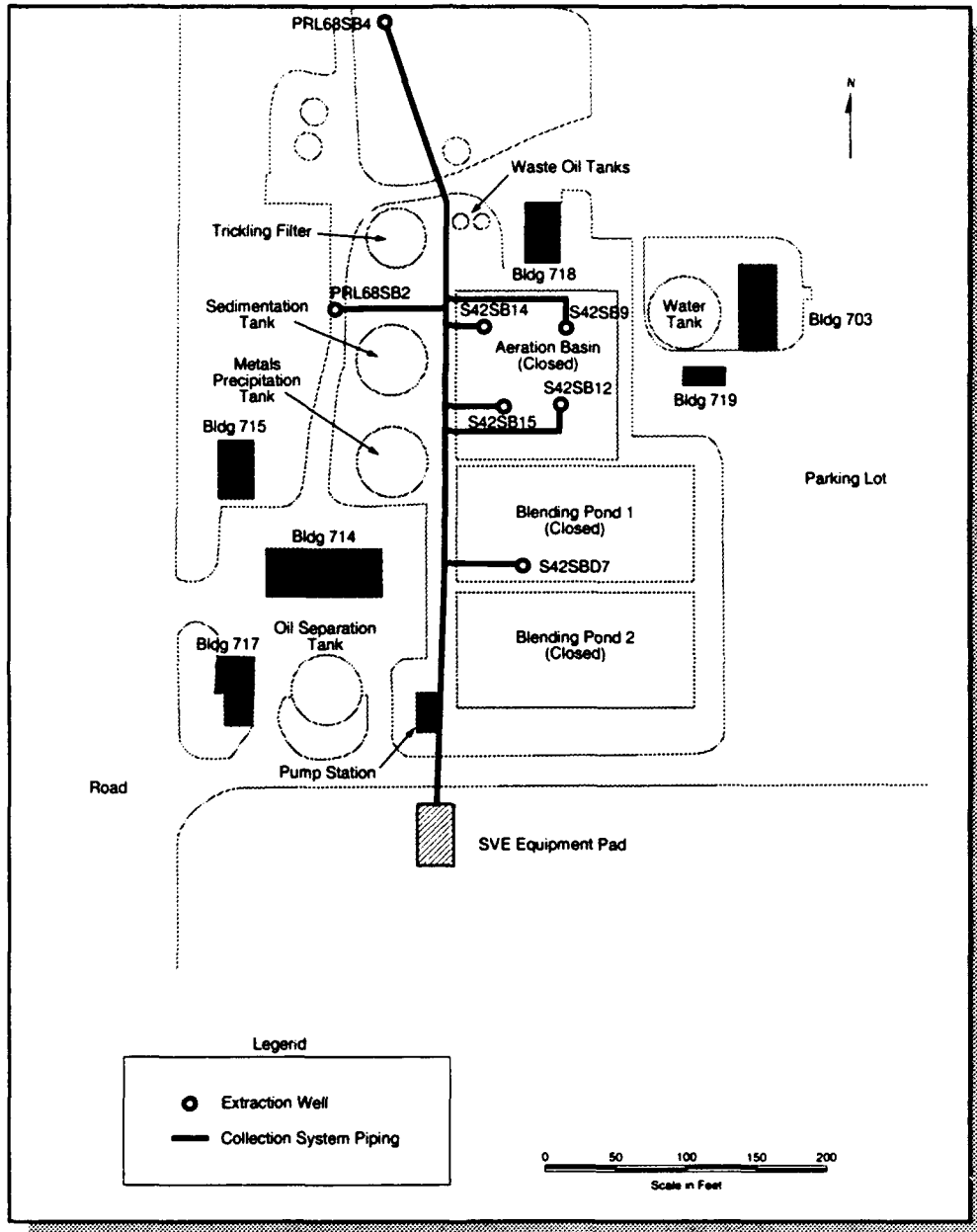

Figure 5-1
 Location for SVE
 System Used in
 Cost Estimate

Section 5

Cost Estimate

The estimated cost for installing and operating the initial SVE system at OU C1 is shown in table 5-1. This estimate is based on the assumption that a significant spreading center will be found beneath the aeration basins. Under this scenario, boreholes will be converted into extraction wells, and the converted investigative boreholes will be sufficient for the SVE removal action. Utility connections are expected to be short because of the proximity to the IWTP, where utilities are present. Construction of a concrete equipment pad in an open area south of the IWTP, and adjacent to Site 22, is planned to avoid interference with operation of the IWTP. Because of the equipment location, SVE piping runs will be longer than those generally used at other sites. The emission control system planned for use is identical to that described in the basewide EE/CA General Evaluation Document. If no evidence of free product is detected beneath the aeration basin, remediation could be completed within three months. If free product is present, remediation might require six to nine months of SVE system operation.

Section 5

Cost Item	Design Basis	Unit Cost	Equipment Cost
Site Preparation:			
Gas Connection	750 feet of 2 inch polyurethane line	\$7.50/foot	\$5,650
Electrical Connection	200 feet of buried 4 inch conduit	\$5.00/foot	1,000
Transformer	12kv 440 v unit	\$13,000	13,000
Water Connection	200 feet of buried 2 inch PVC pipe	\$14.00/foot	2,800
Grading and Equipment Platform	3000 sq. feet of subgrade and concrete	\$6.00/sq. foot	18,000
Equipment:			
Vacuum blowers	2 blowers rated 500-800 scfm @ 7-12 inches of Hg	\$17,000	\$34,000
Air -Water Separator	1 unit 2000 scfm rated @ 18 inches of Hg	\$4,000	4,000
Manifold and Piping	600 feet of 4-8 inch PVC pipe, fittings and support	\$30.00/foot	12,000
Emission Control System	Catalytic oxidizer w/scrubber	\$355,000	305,000
Engineering:	10% of site and equipment cost	\$23,000-\$65,000	35,500
Mobilization:	10% of site and equipment cost	\$23,000-\$65,000	35,500
Total Equipment Cost:			\$466,000
Operation and Maintenance:			
	90% uptime, 648 hours per month		Monthly Operating Cost:
Natural Gas	2425 scfh	\$3.50/1000 scf	\$5,500
Electricity	105 kw	\$.075/kWh	5,100
Water	617 gph	\$1.00/1000 gal	400
Scrubber Chemicals	254 pph	\$350/ton	28,800
Waste Disposal	500 gph	\$3.00/1000 gal	1,000
Testing and Monitoring	1 stack test per month, 9 well analyses per month	\$2,500/sample	25,000
Operating Labor	90 hrs for 2 part-time techs and part-time sample collector	\$70/hour	6,300
Reporting	1 monthly operations report and prorated summary report	\$6,000/month	6,000
Monthly Operating Cost:			\$78,100
Annual Operating Cost:			\$937,200

Table 5-1
SVE Cost
Estimate for
OU C1

Section 6 IMPLEMENTATION PLAN FOR SVE REMOVAL ACTION

The schedule for preparing the documents to support an SVE removal action at IC 1 is shown in figure 6-1. The OU C 1 draft final document was made available for public comment on 1 September 1993. This is followed by a 30-day public review period and a 15-day extension if requested, for a total of 45 days. A 45-day period is planned for McAFB to respond to public comments, finalize the EE/CA, and prepare the responsiveness summary and the action memorandum. The responsiveness summary addresses public comments and the action memorandum is the primary decision document for removal action. All these documents will be placed in the Information Repository and Administrative Record.

A schedule for implementing an SVE system is shown in figure 6-2 to illustrate the sequence of milestone events: design, procurement, off-site equipment assembly, installation, operation, and termination. The SVE design will begin after the date of contract award. An eight-month design period is planned for the traditional design cycle of 10, 40, 90, and 100 percent design submittals and reviews. A one-month interval between the completion of the design and the beginning of equipment installation is allowed for equipment procurement. A three-month period is planned for equipment assembly, which can be done off-site, and a one-month period is planned for on-site installation. The period of operation will be determined as part of the periodic reviews of SVE system performance, currently set for six-month intervals.

The SVE removal action for OU C 1 is part of a basewide removal action including five areas: IC 1, IC7, OU C1, OU D/Site S, and OU D/Site 3. SVE equipment will be installed sequentially at these sites rather than at all sites concurrently. McAFB has not developed an integrated schedule for all five areas, but intends to start the SVE system installation for the last of these five areas before 1 October 1994.

McAFB is not liable for delays in any planned activity in the event of Force Majeure, which is an unforeseen condition as described in the Interagency Agreement among the Air Force, Region 9 of the U.S. Environmental Protection Agency, and the state of California.

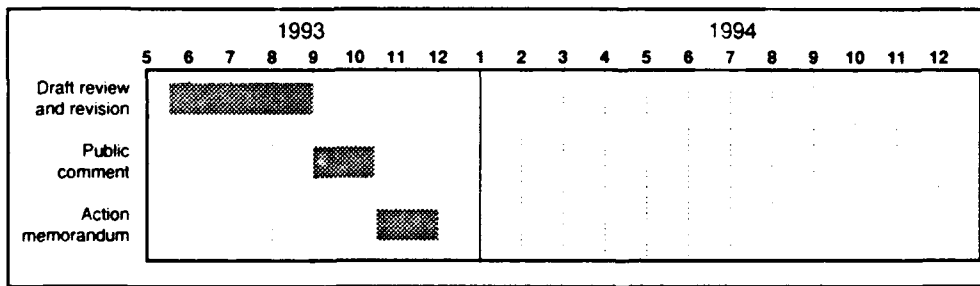

Figure 6-1
Schedule for
EE/CA Site
Specific
Document
for OU C1

Section 6

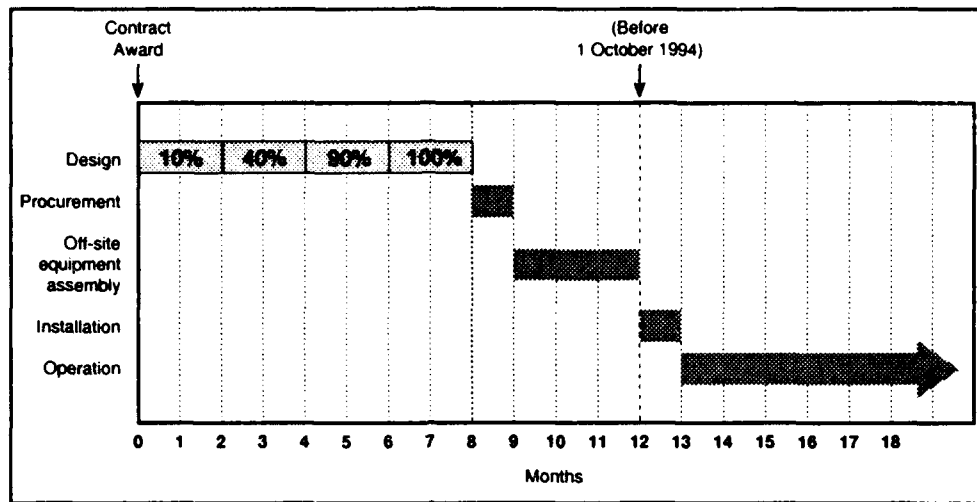

Figure 6-2
*Generic
Schedule for
Implementing
an SVE System*

REFERENCES

CH2M Hill, Inc., *Site Profiles, Delivery Order 5045*, February 1992a.

CH2M Hill, Inc., *Steam Injection/Vacuum Extraction Preliminary Feasibility Assessment and Cost Estimate*, April 1992.

CH2M Hill, Inc., *Draft Laboratory Summary Memorandum Steam Injection/Vacuum Extraction Treatability Investigation, Pre-Design Investigation Site 22 Within Operable Unit C1*, July 1993.

Jacobs Engineering Group, Inc., *Northern Plume Treatability Investigations Sampling and Analysis Plan (Draft)*, 1992b.

Jacobs Engineering Group, Inc., *Operable Unit C1 Remedial Investigation Sampling and Analysis Plan*, December 1992a.

Radian Corporation, *Preliminary Assessment for CS-42*, October 1989b.

Radian Corporation, *Technical Memorandum for CS-22*, October 1989a.

Science Applications International Corporation, *Site 22 Preliminary Data*, October 1991.

GLOSSARY

Chemical Codes

ACE	acetone
BRME	bromomethane
BUTADIEN	1,3-butadiene, erythrene
BZ	benzene
BZLCL	benzyl chloride
BZME	toluene
C8N	n-octane
CHLOROPR	2-chloro-1,3-butadiene
CLBZ	chlorobenzene
CLEA	chloroethane
CLME	chloromethane
CTCL	carbon tetrachloride
CO	carbon monoxide
CYHEXANE	cyclohexane
DCA11	1,1-dichloroethane
DCA12	1,2-dichloroethane
DCBZ12	1,2-dichlorobenzene
DCBZ13	1,3-dichlorobenzene
DCBZ14	1,4-dichlorobenzene
DCE11	1,1-dichloroethene
DCE12C	cis-1,2-dichloroethene
DCE12T	trans-1,2-dichloroethene
DCP13C	cis-1,3-dichloropropene
DCP13T	trans-1,3-dichloropropene
DCPA12	1,2-dichloropropane
EBZ	ethylbenzene
EDB	1,2-dibromoethane (ethylene dibromide)
FC11	trichlorofluoromethane
FC113	1,1,2-trichloro-1,2,2-trifluoroethane
FC12	dichlorodifluoromethane
FC114	freon 114, dichlorotetrafluoroethane
MTLNCL	methylene chloride
MVC	vinyl chloride, monovinylchloride
NOx	nitrogen oxide
PCA	1,1,2,2-tetrachloroethane
PCE	tetrachloroethene
PROP	propylene, propene
SOx	sulphur oxides
STY	styrene
TBME	bromoform
TCA	trichloroethane
TCA111	1,1,1-trichloroethane

GLOSSARY

TCA112	1,1,2-trichloroethane
TCB124	1,2,4-trichlorobenzene
TCE	trichloroethene
TCLME	chloroform
TMB124	1,2,4-trimethylbenzene
TMB135	1,3,5-trimethylbenzene (mesitylene)
UNK	unknown compounds
VC	vinyl chloride
XYLMP	m,p-xylene (sum of isomers)
XYLO	o-xylene (1,2-dimethylbenzene)
XYLP	p-xylene (1,4-dimethylbenzene)

General

ARAR	Applicable or relevant and appropriate requirements
cfm	Cubic feet per minute
EE/CA	Engineering Evaluation-Cost Analysis
EPA	U.S. Environmental Protection Agency
IAG	Interagency Agreement
IC	Investigative cluster
IRP	Installation Restoration Program
McAFB	McClellan Air Force Base
NCP	National Contingency Plan
OU	Operable Unit
ppb	parts per billion
ppm	parts per million
ppmv	parts per million by volume
scfm	standard cubic feet per minute
SMAQMD	Sacramento Metropolitan Air Quality Management District
SVE	Soil vapor extraction
TRC	Technical Review Committee
VOC	Volatile organic compound