

AD-A272 903

ARL-RR-14

AR-008-384



2

DEPARTMENT OF DEFENCE
DEFENCE SCIENCE AND TECHNOLOGY ORGANISATION
AERONAUTICAL RESEARCH LABORATORY
MELBOURNE, VICTORIA

Research Report 14

THE INFLUENCE OF SECONDARY BENDING ON FATIGUE LIFE
IMPROVEMENT IN BOLTED JOINTS

by

R.L. EVANS

S DTIC
 ELECTE
 NOV 16 1993
A

This document has been approved
 for public release and sale; its
 distribution is unlimited.

Approved for public release.

93-28037

© COMMONWEALTH OF AUSTRALIA 1993

AUGUST 1993

93 11 15 066

This work is copyright. Apart from any use as permitted under the Copyright Act 1968, no part may be reproduced by any process without prior written permission from the Australian Government Publishing Services. Requests and enquiries concerning reproduction and rights should be addressed to the Manager, Commonwealth Information Services, Australian Government Publishing Services, GPO Box 84, Canberra ACT 2601.

THE AUTHOR OF THIS REPORT IS AUTHORIZED TO REPRODUCE AND SELL THIS REPORT

DEPARTMENT OF DEFENCE
DEFENCE SCIENCE AND TECHNOLOGY ORGANISATION
AERONAUTICAL RESEARCH LABORATORY

Research Report 14

THE INFLUENCE OF SECONDARY BENDING ON FATIGUE LIFE
IMPROVEMENT IN BOLTED JOINTS

by

R.L. EVANS

SUMMARY

Secondary bending often occurs in structural joints, and to assess its influence on the fatigue life enhancement technique of hole cold-expansion, an experimental program has been undertaken. The results indicate that the effect of cold working is substantially reduced in specimens with secondary bending. For any marked extension in fatigue life, additional treatments, for example, the combination of cold expansion and interference fit, are required.



© COMMONWEALTH OF AUSTRALIA 1993

POSTAL ADDRESS: Director, Aeronautical Research Laboratory,
506 Lorimer Street, Fishermens Bend,
Victoria, 3207, Australia.

TABLE OF CONTENTS

	Page No.
1. INTRODUCTION.....	1
2. MATERIAL AND SPECIMENS.....	1
3. TESTING DETAILS.....	2
4. RESULTS AND DISCUSSION.....	3
4.1 Fatigue Lives.....	3
4.2 Failure Types.....	5
4.3 Specimen Fractures.....	5
4.3.1 Non cold-expanded specimens.....	5
4.3.2 Cold-expanded specimens.....	6
4.3.3 Cold-expanded specimens with interference-fit bolts.....	6
4.3.4 Non cold-expanded specimens with sealant.....	6
4.3.5 Cold-expanded specimens with sealant.....	6
4.3.6 Cold-expanded specimens with interference-fit bolts and sealant.....	6
4.3.7 Non-bending non cold-expanded, and non-bending cold-expanded specimens.....	7
5. CONCLUSIONS.....	7
6. ACKNOWLEDGEMENTS.....	7
REFERENCES.....	8
TABLES 1-4	
FIGURES 1-8	
APPENDIX A: Component List and Assembly Procedure	
B: Fastener Fits	
DISTRIBUTION	
DOCUMENT CONTROL DATA	

BASIC QUALITY INSPECTED 8

Accession For	
NTIS GRA&I	✓
DTIC TAB	□
Unannounced	□
Justification	
By _____	
Date _____	
Agency Use	
Date	Acquisition Source
A-1	

1. INTRODUCTION

Considerable work has been done at the Aeronautical Research Laboratory (ARL) and elsewhere on improving the fatigue performance of bolted joints by cold working¹ the bolt holes and/or using interference-fit bolts. Fatigue life enhancement greater than 100% is usually reported [1-4].

In most programs concerned with establishing the beneficial effects of cold working, the test specimens used are designed to eliminate secondary bending², yet secondary bending is common in aircraft structures. For example, Schütz and Lowak [5] have reported that 86% of construction details measured in aircraft were found to exhibit secondary bending. An AGARD collaborative program [6] has shown that secondary bending in a bolted joint may eliminate the positive effect on fatigue life of hole cold-working. These findings are disconcerting as cold working is often specified as a remedy for fatigue sensitive portions of aircraft structure. The McDonnell Douglas F/A-18 Hornet in service with the Royal Australian Air Force (RAAF) makes extensive use of hole cold-working during manufacture.

A test program was undertaken at ARL to gauge the effect of secondary bending on the fatigue life of joints with and without hole cold-working and interference-fit bolts. One level of interference fit and one level of cold expansion were used in this test program. An alloy of high strength/weight used in the F/A-18 was chosen for the specimens, and a loading sequence derived from RAAF experience with the Hornet was applied.

2. MATERIAL AND SPECIMENS

The main specimen type of this investigation is a bolted joint designed to produce secondary bending when axially loaded. The secondary-bending specimen (Figure 1) is a slightly modified version of the UK Q-joint [7]. It is comprised of three main members (two 5 mm thick components and one 3 mm thick component) and two spacers. The modification with respect to the UK Q-joint is an extension of the gripping portion of the specimen from 60 mm to 75 mm to allow easier gripping in ARL test machines. It is believed, that provided the specimen is fully inserted in the grips, no changes occur to the secondary-bending characteristics. The main specimen components are machined from 0.25 inch thick 7075-T651 aluminium alloy plate. The chemical composition of the alloy is given in Table 1 and the mechanical properties in Table 2.

The UK Q-joint components were treated with Alocromed, and sealant was used in their assembly. Approximately half (22 of 53) of the ARL specimens were surface treated according to that specified for the F/A-18 (to improve corrosion resistance and paint adhesion). The surface treatment consisted of a chemical coating which was applied as per [10], and PR 1422-B2 sealant which was used between components during assembly. The remainder of the specimens were assembled without surface treatments and they indicated a larger amount and a higher concentration of fretting³ under fatigue loading compared to those

¹The method used at ARL is the Boeing-developed split-sleeve hole cold-expansion system now marketed by Fatigue Technology Inc. (FTI) of Seattle, U.S.A.

²Secondary bending is the superposition of bending stresses on axial stresses as a result of eccentricities of lines of force acting on a cross-sectional transition or other discontinuity in construction. It is restricted to a small area and is calculable only with difficulty (a paraphrase of the definition given in [5]).

³Fretting arises when tightly fitting parts experience microscopic relative motions. The process involves the formation of pits on the facing surfaces and the creation of powdered products which are generally oxides of the contacting metals.

which were surface treated. The specimens with sealant (and chemical coating) were more representative of an F/A-18 joint.

Four test specimens of a simpler joint with no secondary bending were used to provide information on the fatigue life extension produced by hole cold-working under the loading sequence used. These symmetrical non-bending specimens were assembled from three of the 5 mm components (plus the 5 mm spacer) used in the secondary-bending specimens. Two of the components straddled the spacer and, at the other end, the third 5 mm component. Hence, compared to the secondary-bending specimens of Figure 1, the non-bending specimens did not have a 2 mm spacer, and the 3 mm component was replaced by another 5 mm component.

Specimens were assembled to give the following conditions and were tested at two main peak stress levels;

(i) Secondary-bending specimens

NCE, NCES Non Cold-Expanded, Non Cold-Expanded with Sealant
neat-fit bolts in plain holes,

CE, CES Cold Expanded, Cold Expanded with Sealant
neat-fit bolts in cold-worked holes,

CE+I, CES+I Cold Expanded + Interference Fit,
Cold Expanded + Interference Fit with Sealant,
interference-fit bolts in cold-worked holes, and

(ii) Non-secondary-bending specimens

NBNCE, NBCE Non-Bending Non Cold-Expanded, Non-Bending Cold Expanded
neat-fit bolts in plain holes, neat-fit bolts in cold-worked holes.

Each specimen component (excluding spacers) was prepared with 6.0 mm diameter reamed pilot bolt holes, from 5.7 mm diameter drilled holes. The final target bolt hole size, whether cold worked or non cold-worked, was 6.31 mm. Non cold-worked holes were reamed to the final 6.31 mm diameter. Cold-worked holes were cold expanded 0.24 mm (4.0%) by the Boeing split-sleeve system (described in detail in [11]) with the split positioned in line with the loading axis and away from the test section. They were then reamed to 6.31 mm diameter. A precision bore-gauge was used to measure hole diameter to the nearest 0.001 mm. The interference-fit bolts, machined to a diameter of 6.38 mm, were inserted after cold expansion and reaming of the holes, using a fatigue test machine and barium chromate lubricant. An interference fit of 0.07 mm (1.1%) between the finished hole and fastener diameter ensued. The specimen supplementary parts list is shown in Table 3. A more detailed assembly description, and the fastener fits for each group of secondary-bending specimens, are included as Appendix A and Appendix B, respectively.

3. TESTING DETAILS

The fatigue tests of the secondary-bending specimens were carried out under an F/A-18 manoeuvre loading program described in [12]. Each repeated loading block (program) was equivalent to 255.4 flight hours and consisted of 18648 turning points in 269 discrete loading levels, with a minimum stress of $-0.2\sigma_{max}$.

The testing was conducted in an Instron 250 kN test machine with PC interface, at an average frequency of 1.6 Hz. The majority of the secondary-bending specimen tests were made at net-area stress levels of 270 MPa or 350 MPa resulting in a practical range of lives. The net area used in stress calculations was the minimum cross-sectional area of the bottom component of Figure 1 (through the bottom set of holes) and was 191.9 mm². A few tests were run at net-area stress levels of 300 MPa or 320 MPa. The four non-bending specimens were tested at a net-area stress level of 350 MPa only.

SPATE (Stress Pattern Analysis by measurement of Thermal Emission) measurements were also performed on a secondary-bending specimen (number SQ75). This thermoelastic method was used to measure the whole-field bulk stress pattern on the surface of the specimen. Hence, the stress fields of the specimen, including its secondary bending trends, were obtained experimentally. These measurements show the influence of secondary bending on the stresses and are compared to results from a two-dimensional finite element study of the bolted joints in a separate report [13].

4. RESULTS AND DISCUSSION

All fatigue test results together with details of the locations of failure origins and fatigue fracture characteristics for each specimen are given in Table 4. Figure 2 shows the effect of different treatments on the fatigue lives of the specimens, while Figure 3 is a graphical presentation of all the fatigue lives. Photographs of representative fracture surfaces are illustrated in Figure 4, and Figure 5 explains the designation of the regions (A, B, C, D, E, F, G) of the origins of the primary fatigue cracks. The displacement profile of the loaded secondary-bending specimen is shown in Figure 6. Figures 7 and 8 are photographs of the disassembled CE specimen Q25 after testing, and the fractured main component (through holes A and B) of the specimen, respectively.

4.1 Fatigue Lives

A two-way analysis of variance of the fatigue data from the secondary-bending specimens (Table 4) indicated that cold expansion provides a significant increase in fatigue life compared with the reaming-only process of the holes of the non cold-expanded specimens. This was the case for corresponding specimen groups with and without sealant (refer to Figures 2a and 2b). However, when comparisons are made at individual stress levels, the increase in life due to cold expansion is significant only at the 270 MPa level. The average increase in life experienced by these secondary-bending specimens ranged from 5% for those without sealant at a net-area stress level of 350 MPa, to 102% for those with sealant at a net-area stress level of 270 MPa.

Percentage Increase in Life Due to Cold Expansion

Stress Level (MPa)	No Sealant	Sealant
270	66	102
300	17	-
320	13	-
350	5	35

The effect of cold expansion on fatigue-life improvement is substantially reduced in specimens with secondary bending compared to those without [1-4], where life improvements of 125% to 302% were reported.

There was no significant interaction between stress level and the application or not of sealant for all specimens ie, the influence of sealant on fatigue life was not stress-level dependent.

A comparison of the data for the NCE and NCES specimens (Figure 2c) and the CE and CES specimens (Figure 2d) shows that for both cases there is no significant difference in fatigue life resulting from the addition of a surface treatment (chemical coating and sealant) as compared to plain aluminium. It was believed that the sealant would reduce the amount of fretting and hence improve the fatigue life, and in practice the amount of fretting was reduced. However, the resultant load transfer through friction would also be reduced which, in turn, would detrimentally affect the fatigue life of the specimens with sealant.

A statistical analysis of NCE and CE+I, and CE and CE+I specimens showed that there was no significant difference between the fatigue lives of the different treatments. This was due to the low number of CE+I samples. On average the CE+I specimens had an increased fatigue life of 55% over the NCE specimens, and 47% over the CE group, at the net-area stress level of 350 MPa.

Figure 3 clearly shows that the CES+I specimens survived the longest. Statistically, for the groups NCES and CES+I, and CES and CES+I, there was an overall significant difference between the fatigue lives of the different treatments (Figures 2e and 2f, respectively). However, when comparisons are made at individual stress levels, the increase in life due to CES+I over NCES is significant only at the 270 MPa stress level. The increase in life due to CES+I over CES is significant at both the 270 MPa and the 350 MPa stress levels. The average increase in life experienced by these CES+I secondary-bending specimens ranged from 83% over those with cold expansion at a net-area stress level of 350 MPa, to 420% over those without cold expansion at a net-area stress level of 270 MPa, as shown below.

Percentage Increase in Life Due to Cold Expansion and Interference-Fit Bolts (with sealant)

Stress Level (MPa)	Compared to NCES	Compared to CES
270	420	157
350	147	83

For the net-area stress level of 350 MPa, the CES+I group was the only group to improve on the fatigue life of the NBCE specimens (by an average of 28%).

The percentage improvement in average life of the secondary-bending specimens CE compared to NCE, CES compared to NCES, CES+I compared to NCES, and CES+I compared to CES, increased as life increased ie, the lower the stress level, the longer the life, and the greater the effect of treatment on life. However, the effect of cold expansion as compared to reamed-only holes on the fatigue life of the non-bending specimens, was much less than anticipated; 35%. This abnormality may be explained by: (i) only two specimens of each type were tested, and (ii) the specimens experienced fairly short lives (at a net-area stress level of 350 MPa).

The results of this fatigue test program agree with those (that are relevant) of [6], namely high values of secondary bending (as experienced by the Q-joint) in specimens tend to nullify the effect of fatigue life enhancement fastener systems, and the highest fatigue lives are obtained with a combination of hole cold-expansion and interference-fit fasteners.

4.2 Failure Types

There were three main origins of failure;

- Type 1 from inside the bore of the hole,
- Type 2 on the surface close to the holes, and
- Type 3 on the surface well away from the holes.

Combinations of these types were common, especially the mixture of Type 1 and Type 2.

Failure Type 1 emanates from the inside of the bolt hole's diameter (Figure 4a) at multiple sites. The fatigue cracks appear to be initiated by the fretting between the bolt and the specimen, or from scratches/faults in the metal surface of the bolt hole diameter. The specimens which failed by Type 1 alone were; non-bending, most of NCE (6 of 7), and one CE (1 of 7). Half of the NCE Type 1 failures were through the relatively uncommon location of holes C and D (refer to Figure 5).

Type 2 failures are typical of those from multi-layer specimens with cold-expanded holes. They are initiated by the fretting of the out-of-plane protrusions of the faying surfaces, associated with the cold-expansion process. Hence, the fatigue cracks originate from the surface close to the cold-expanded holes (Figure 4b). Eleven of the twelve CE specimens failed by Type 2 alone through holes A and B. Four of the seven CE specimens also failed this way. The other CE and CE specimens tended to be a combination of Type 1 and Type 2 failures.

Failure Type 3 originates from one of the faying surfaces quite a distance from the holes (Figure 4c). This type of fatigue crack was a main contributor to the failure of four of the five CE+1 specimens. Fretting was not an apparent cause of these surface cracks.

4.3 Specimen Fractures

4.3.1 Non cold-expanded specimens

The secondary-bending NCE specimens exhibited a mixture of the three types of fatigue fracture (Table 4). All failures were through holes A and B. There was, predominantly, a combination of failure types in both holes. Five of the thirteen specimens also had one or two very small cracks of Type 3 (denoted by '*' in Table 4) on their fracture surfaces. The faying surfaces had a fair amount of fretting around the holes and also at quite a distance from the holes. There was a large amount of fretting around holes C and D on the 3 mm component side and on the surface (away from the holes) on the 5 mm component side.

The failure origins of the NCE specimens were hence principally due to the fretting of metal surfaces - bolt/aluminium, and aluminium/aluminium. Figure 6 is the displacement diagram of one of the theoretical models adapted from [13] (gripping sections are omitted). It shows that the larger amount of fretting around holes C and D on the 3 mm component side is possibly due to the way the specimen deforms under load. The specimen is experiencing an increased tensile stress in that location. At the A/B location, the main component of the specimen seems to be undergoing a point of inflection. However, the ultimate failure of the NCE specimens occurred at holes A and B as the cross sectional area, of these specimens, is the predominant factor compared to the increased bending stress at holes C and D.

4.3.2 Cold-expanded specimens

As mentioned in Section 4.2, the CE specimens all experienced Type 2 failures through holes A and B (except for Q14 which had a combination Type 1 and Type 2 failure of hole A and a Type 2 failure of hole B). Fretting was very concentrated on the surfaces around all the holes, with a greater intensity about the C and D holes on the side of the 3 mm component (as with the NCE specimens). The cold-expansion process therefore localises the origin of failure to the surface close to the holes. The out-of-plane protrusions created by the Boeing split-sleeve cold-expansion process become preferred sites of fretting, and ultimately failure.

4.3.3 Cold-expanded specimens with interference-fit bolts

The two CE+I specimens failed through holes A and B; one by Type 2, and the other from a combination of Type 1 and Type 2 fatigue cracks. The fretting locations were coincident with those of the CE specimens. Thus, the general mode of failure was similar to that in CE specimens but with the addition, in one case, of a Type 1 failure.

4.3.4 Non cold-expanded specimens with sealant

Half of the Type 1 failures of the NCES specimens occurred at A and B holes and the other half at holes C and D. Specimen SQ57 failed by a Type 1 fracture in hole A and a Type 2 crack in hole B (Figure 4d). There was less fretting on the component surfaces, but more in the vicinity of the holes, compared to the NCE specimens. The fractures of the three specimens that failed through holes C and D were not symmetrical through the thickness. The initiation of the fatigue cracks tended towards the 3 mm component.

The sealant tended to reduce load transfer through friction. This was indicated by a reduced amount of fretting of the metal surfaces compared to the NCE specimens, and resulted in an increase in the movement of the bolts (hence, Type 1 failures). As previously mentioned, the deformed shape of the loaded secondary-bending specimens (increased tensile stresses in holes C and D) possibly influences the location of fretting, hence failure. The positions of the Type 1 failures tend to suggest that the stresses at holes A and B, primarily due to minimum cross-sectional area and fretting; and those at C and D, due to increased bending stresses and fretting, are similar in magnitude.

4.3.5 Cold-expanded specimens with sealant

Of the seven CES specimens, four had Type 2 failures, and two had a combination of Type 1 and Type 2 failures, through holes A and B. One CES specimen (SQ 55) failed through holes C and D with a Type 1 fracture. The CES specimens seemed to have less fretting on the contacting surfaces than the NCES group. As with the CE specimens, the fretting of the CES specimens was localised to around the holes, with a greater intensity about the C and D holes on the side of the 3 mm component. Thus, as mentioned above, cold expansion tends to concentrate the failure origin to the surface close to the holes. However, as indicated by the NCES group, the sealant appears to affect load transfer, resulting in some failures other than the expected Type 2 at holes A and B, in the CES group of specimens.

4.3.6 Cold-expanded specimens with interference-fit bolts and sealant

All the CES+I specimens fractured by a mixture of failure types. The five specimens failed through hole A, or A and B holes, by small cracks of Type 2, or a combination of Type 1 and

Type 2. Four of the five also had large Type 3 failures in regions E, F or G (refer to Table 4 and Figures 4c and 5). Specimen SQ78 had a very small Type 3 crack on its fracture surface. The specimens exhibited fretting characteristics like those of the CES group. However, the CES+I specimens also had some fretting around the edges of the end of the 3 mm component and correspondingly on the adjacent 5 mm component. Fretting was not present in the regions of the large Type 3 cracks even though they originated from the faying surface of the main component. The employment of interference-fit bolts compared to neat-fit bolts tends to relocate the primary fatigue origin away from the holes. The C and D Type 1 failures of the CES group are eliminated by the use of interference-fit bolts. The resultant high friction forces generated by the 1.1% interference fit substantially reduce fretting at the bolt/aluminium interface. Figure 6 shows that the E/F/G region in the main component experiences an increased tensile stress (on the side adjacent to the other 5 mm component) compared to region A/B. It appears that these factors may be the cause of the CES+I Type 3 origin of failure.

4.3.7 Non-bending non cold-expanded, and non-bending cold-expanded specimens

The non-bending (NB) specimens, both NCE and CE, experienced Type 1 failure through holes A and B. Fretting occurred between the bolts and the hole inner surface resulting in failure of the specimen emanating from the bore of the hole, and discolouration of the fracture surfaces due to the fretting products. The fatigue failure regions were symmetrical through the thickness of the specimen, indicating the absence of bending stresses.

5. CONCLUSIONS

1. This test program has indicated that secondary bending in bolted joints reduces the effectiveness normally associated with cold expansion in extending fatigue life. For any marked extension in fatigue life of these joints, additional treatments/processes are required (eg. interference-fit bolts, in addition to cold expansion). Overall, cold expansion did significantly increase the fatigue life of the specimens as compared to non cold-expanded specimens, but not to the extent normally obtained with non-bending specimens.
2. The additional stresses introduced by secondary bending tended to move the failure origin away from the minimum cross-sectional area, and bore of the bolt hole. The failure location was also influenced by the presence of sealant and the degree of interference of the bolts.
3. The application of sealant to the chemically coated specimens, as compared to those without surface treatment and sealant, did not significantly improve the average fatigue life of either cold-expanded or non cold-expanded specimens. Although the application of sealant reduced the amount of fretting between components of the specimens, it apparently also decreased the load transfer through friction which, in turn, detrimentally affected fatigue life.

6. ACKNOWLEDGEMENTS

The author wishes to express her thanks to Mr A Machin and Dr J Finney for their sizeable contributions towards this report, and to Mr M Dvorak and Mr N Absolom for the assembly and testing of specimens.

REFERENCES

1. JY Mann, AS Machin, WF Lupson & RA Pell, "The Use of Interference-Fit Bolts or Bushes and Hole Cold Expansion for Increasing the Fatigue Life of Thick-Section Aluminium Alloy Bolted Joints", Aug 1983. ARL-STRUC-NOTE-490.
2. MW Ozelton & TG Coyle, "Fatigue Life Improvement by Cold Working Fastener Holes in 7050 Aluminium", *Fatigue in Mechanically Fastened Composite and Metallic Joints*, ASTM STP 927, John M Potter, Ed., American Society for Testing and Materials, Philadelphia, 1986 pp 53-71.
3. JY Mann, GW Revill & WF Lupson, "Improving the Fatigue Performance of Thick Aluminium Alloy Bolted Joints by Hole Expansion and the Use of Interference-Fit Steel Bushes", Apr 1983. ARL-STRUC-NOTE-486.
4. LF Impellizzeri & DL Rich, "Fatigue Analysis of Cold-Worked and Interference Fit Fastener Holes" on *Cyclic Stress-Strain and Plastic Deformation Aspects of Fatigue Crack Growth* ASTM STP 637, ASTM 1977 pp 153-175.
5. D Schütz & H Lowak, "The Effect of Secondary Bending on the Fatigue Strength of Joints". 1974. RAE Library Translation No. 1858.
6. HH van der Linden (Ed.), "Fatigue Rated Fastener Systems - An AGARD Coordinated Testing Program", May 1985. AGARD-R-721.
7. R Cook, "Standard Fatigue Test Specimens for Fastener Evaluation", Nov 1987. AGARD-AG-304.
8. "Metals Handbook", 9th edition, Volume 2, Dec 1980, American Society for Metals. pp 129, 130.
9. "MIL-HDBK-5F", 1 Nov 1990. Figure 3.7.4.1.6(g). page 3-352.
10. ASTA Engineering Process Specification No. 267, "Application of Conversion Coatings", Issue 6, Apr 1992.
11. JL Phillips, "Fatigue Improvement by Sleeve Cold Working", Oct 1973. SAE Paper No. 73095.
12. JM Finney, "Coupon Fatigue Test Comparisons of US and Australian F/A-18 Bulkhead Sequences", Sep 1991. ARL-STRUC-TM-546.
13. RL Evans & M Heller, "Stress Analysis of a Secondary Bending Specimen". ARL Document in preparation, 1993.

TABLE 1
Chemical composition of unclad 7075 aluminium alloy

Element	Specification Limits (8)	Specimen Material
Zinc	5.1 - 6.1	5.5
Magnesium	2.1 - 2.9	2.4
Copper	1.2 - 2.0	1.5
Iron	0.5 max	0.26
Chromium	0.18 - 0.28	0.20
Silicon	0.4 max	0.11
Manganese	0.3 max	0.09
Titanium	0.2 max	0.02
Others : <i>each</i>	0.05 max	0.01
: <i>total</i>	0.15 max	<0.05
Aluminium	Remainder	Remainder

TABLE 2
Mechanical properties of unclad 7075-T651 aluminium alloy

Category	Typical Properties (8, 9)	Experimental Values	
		Average of 5 tests	Standard Deviation
0.1% Proof Stress (MPa):	527.3	526.3	4.5
0.2% Proof Stress (MPa):	539.0	530.4	2.6
Ultimate Tensile Strength (MPa):	572.3	573.8	1.1
Elongation (%): gauge length 50 mm	11.0	12.3	1.6
0.1% Proof Stress/UTS:	0.92	0.92	

TABLE 3
Supplementary parts list for Q-joint specimens

Component	Part Number
Cold-expansion sleeves	CBS-B-0-N-23F
Bolts : Neat-fit	NAS 464P4-6 and -11
: Interference-fit	NAS 3004-7 and -11
Nuts	MS21044-N4
Washers	1/4" flat steel CAD plated
Sealant	PR 1422-B2
Dowels	5 mm ϕ Silver Steel

TABLE 4
Q-joint fatigue test results

(a) Secondary-bending specimens

Hole Treatment	Spec. No.	Stress (MPa)	Life (flight hours)	Log. Mean Life (flt. hours)	Failure Type at Location:				
					A	B	C	D	
Non Cold-Expanded Bolt Holes	Q5	270	12335	10642	1,2	2,3			
	Q9	270	10544			2,3	*		
	Q1	270	10279			2	*		
	Q7	270	9595			1,2	1	*	
	Q2	300	8841	8841	2	3			
	Q6	320	10297	7574	1,2,3	2,3			
	Q8	320	9368			1,3	1		
	Q4	320	7117			1,2	2		
	Q21	320	6303			1,2,3	2,3		
	Q10	320	5762			2	2	*	
	Q23	350	5506	4631	1,3	1,2,3			
	Q26	350	4959			1	2		
Q24	350	3638			2	1,2	*		
Cold-Expanded Bolt Holes	Q19	270	21597	17648	2	2			
	Q13	270	20332			2	2		
	Q16	270	18170			2	2		
	Q17	270	12159			2	2		
	Q11	300	10359	10359	2	2			
	Q20	320	9350	8536	2	2			
	Q18	320	8857			2	2		
	Q12	320	8574			2	2		
	Q14	320	7479			1,2	2		
	Q27	350	5189	4865	2	2			
Q25	350	4915			2	2			
Q22	350	4515			2	2			
Cold-Expanded Interference-Fit Bolt Holes	Q41	350	5504	7177	2	2			
	Q40	350	6056		1,2	1,2			
Non Cold-Expanded Bolt Holes with Sealant	SQ74	270	14476	8365	1	1			
	SQ59	270	8760				1	1	
	SQ51	270	6703			1	1		
	SQ53	270	5762			1	1		
	SQ57	350	8249	4350	1	2			
	SQ58	350	5180				1	1	
SQ52	350	1926			1	1			
Cold-Expanded Bolt Holes with Sealant	SQ62	270	18021	16945	2	2			
	SQ73	270	17193			2	2		
	SQ77	270	15703			1,2	2		
	SQ56	350	6764	5863	1,2	1,2			
	SQ61	350	6558			2	2		
	SQ55	350	5333					1	1
	SQ60	350	4995			2	2		

Continued

TABLE 4
Q-joint fatigue test results (cont.)

(a) Secondary-bending specimens

Hole Treatment	Spec. No.	Stress (MPa)	Life (flight hours)	Log. Mean Life (flt. hours)	Failure Type at Location:				
					A	B	E	F	G
Cold-Expanded Bolt Holes & Interference-Fit Bolts with Sealant	SQ76	270	49219	43521	2				3
	SQ71	270	38483		1,2	1,2	3		
	SQ70	350	16017		1,2	2		3	3
	SQ79	350	9879	10743	1,2	1,2		3	3
	SQ78	350	7835		2	1,2 *			
	SQ75	350	7232 ¹						

(b) Non-bending specimens

Hole Treatment	Spec. No.	Stress (MPa)	Life (flight hours)	Log. Mean Life (flt. hours)	Failure Type at Location:	
					A	B
Non Cold-Expanded	Q30	350	8099	6216	1	1
	Q32	350	4771		1	1
Cold-Expanded	Q31	350	8504	8391	1	1
	Q29	350	8279		1	1

* One or two very small surface cracks were present, however, their contribution towards failure of the specimen was negligible.

¹ Specimen completed 640300 cycles (@ 2.6 - 54.7 MPa) during SPATE testing prior to fatigue testing, hence SQ75 fatigue result is disregarded.

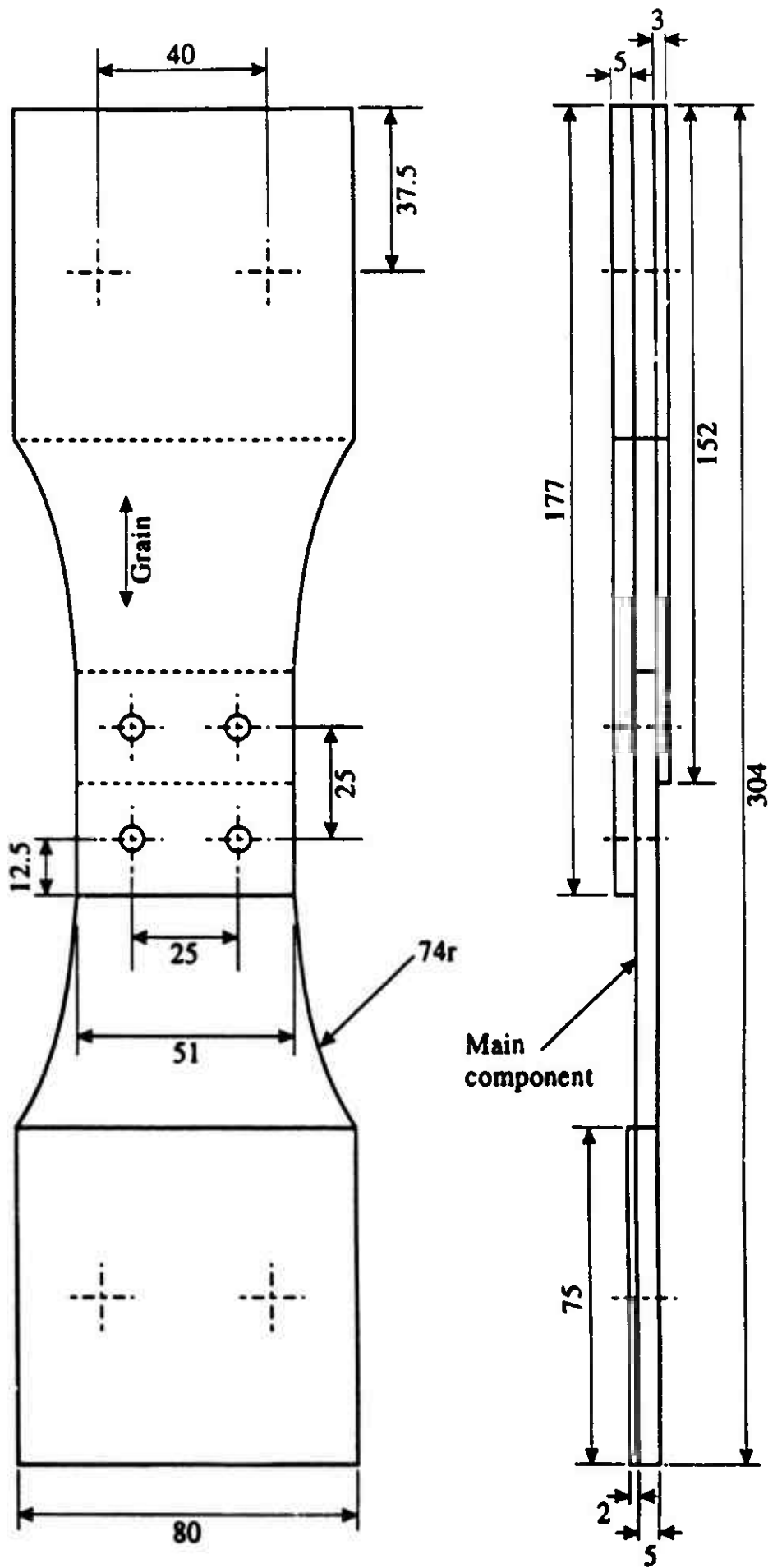

Dimensions in mm

FIGURE 1: ARL Q-joint secondary-bending specimen

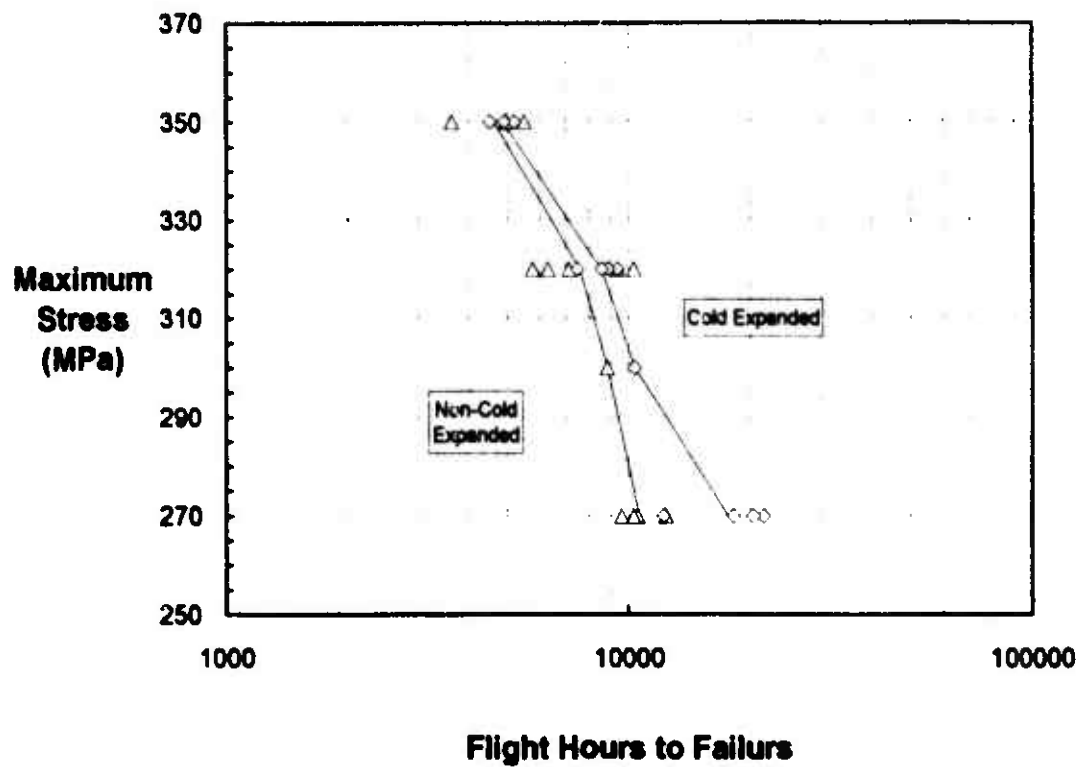

(a): Non cold-expanded vs cold-expanded specimens

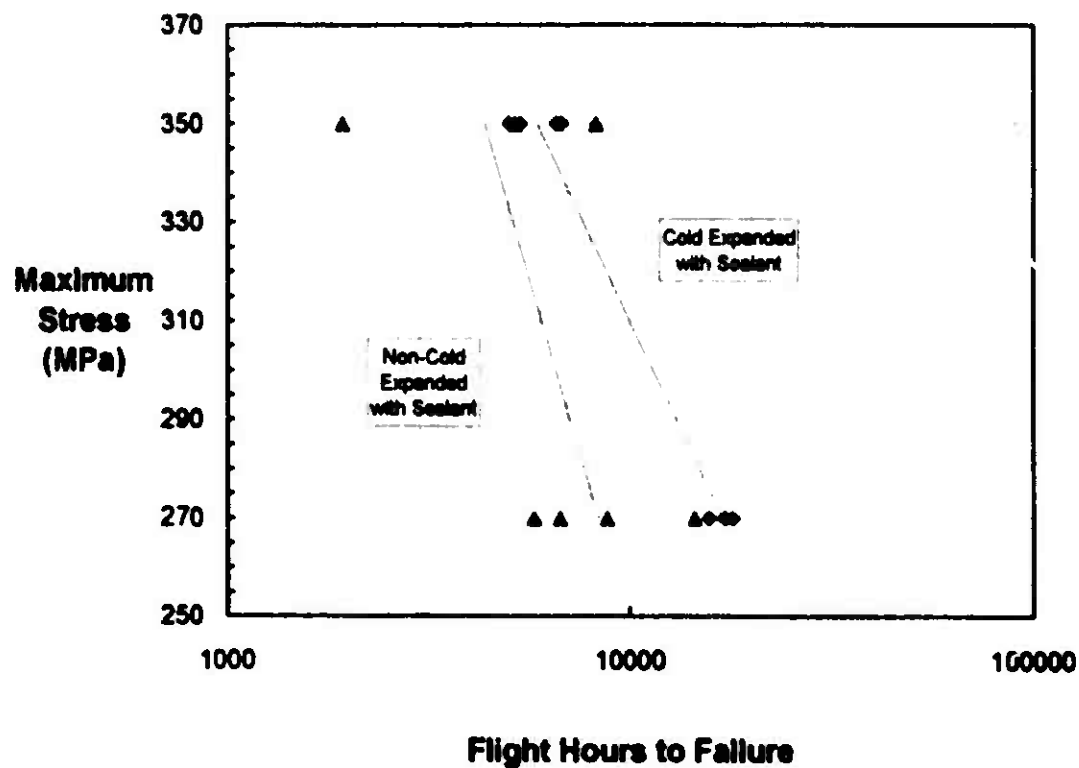

(b): Non cold-expanded vs cold-expanded specimens, with sealant

FIGURE 2: Effect of treatment on fatigue life of Q-joints (cont.)

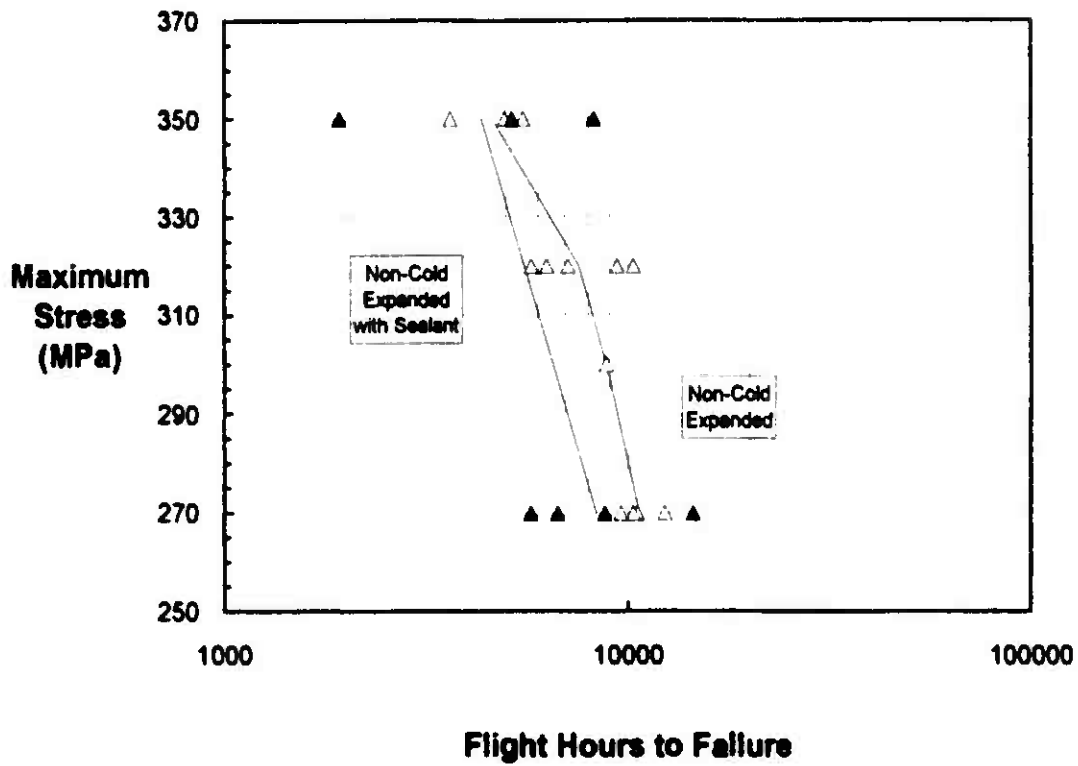

(c): Non cold-expanded specimens with and without sealant

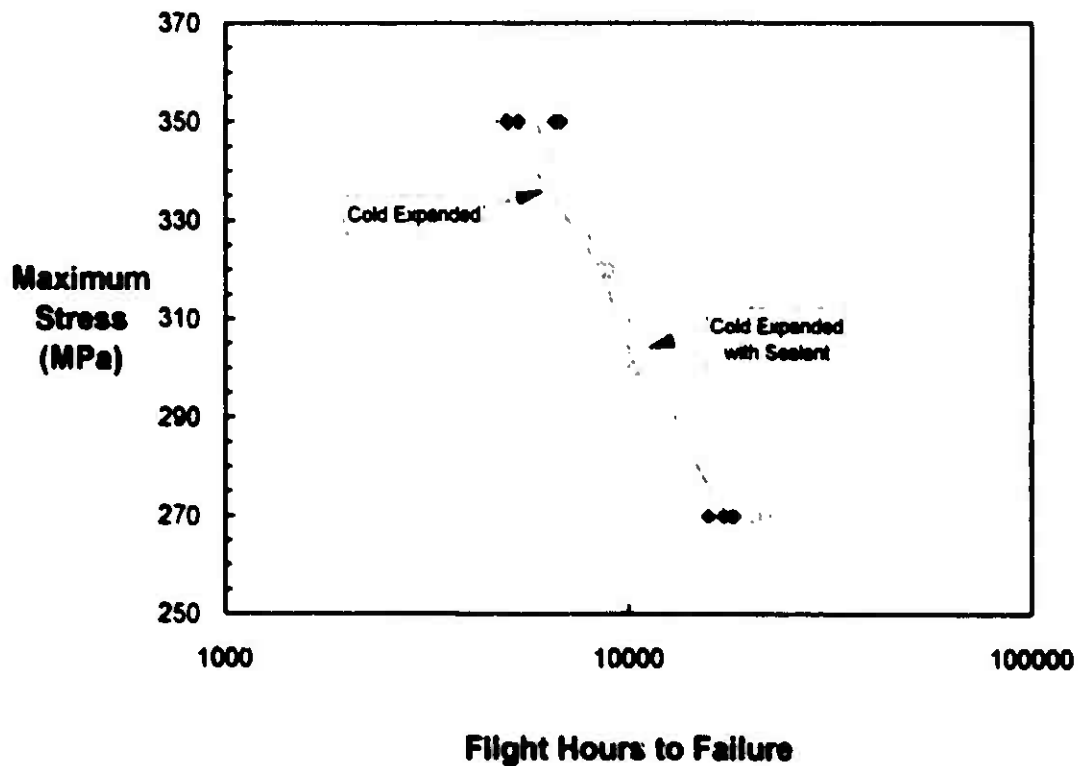

(d): Cold-expanded specimens with and without sealant

FIGURE 2: Effect of treatment on fatigue life of Q-joints (cont.)

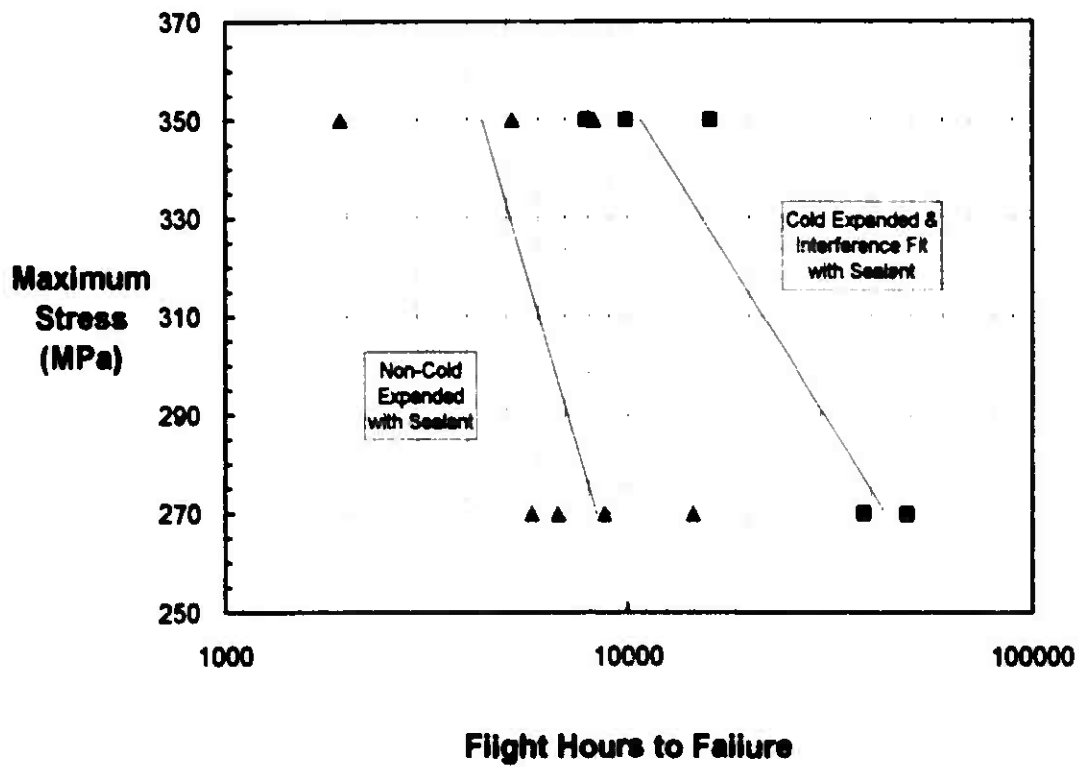

(e): Non cold-expanded vs cold expanded + interference fit, with sealant

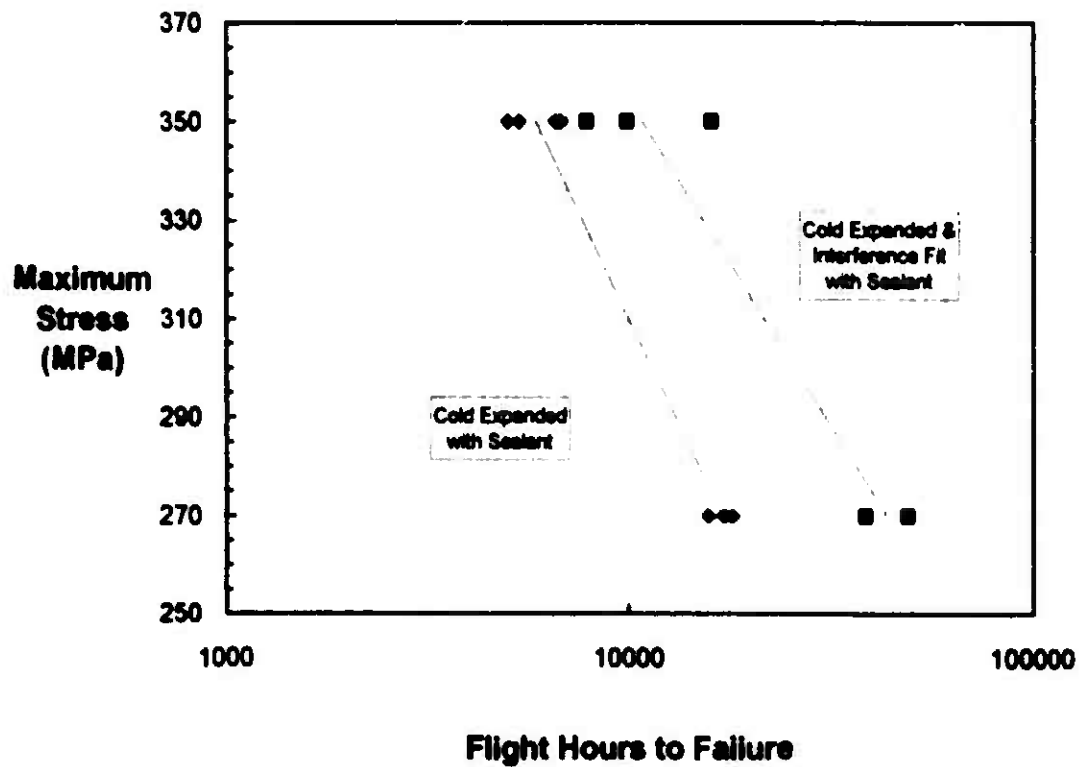

(f): Cold expanded vs cold expanded + interference fit, with sealant

FIGURE 2: Effect of treatment on fatigue life of Q-joints

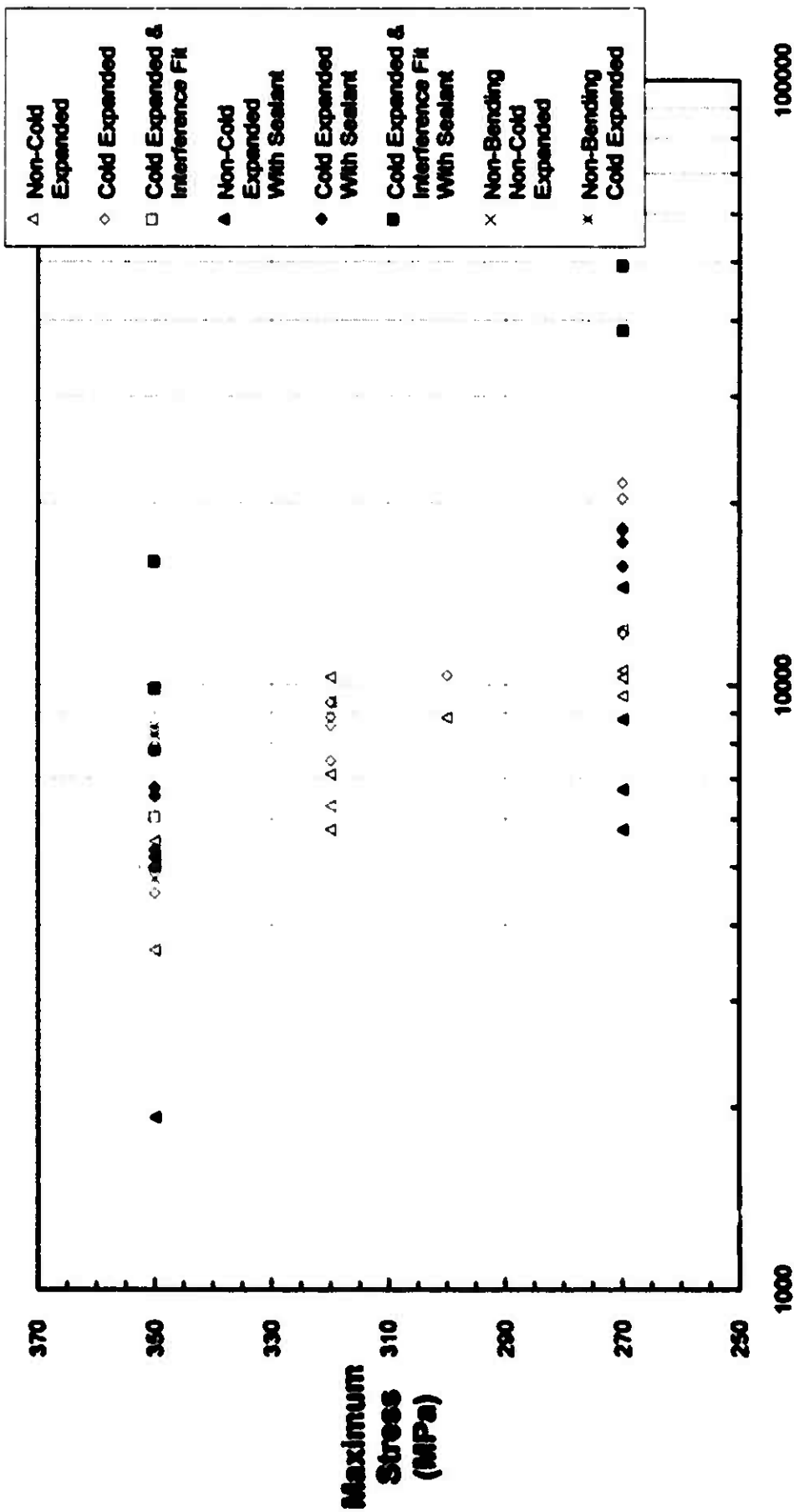

FIGURE 3: Secondary-bending specimen fatigue test results



(a): Type 1 failure of NBCE specimen Q29



(b): Type 2 failure of CE specimen Q25

FIGURE 4: Failure Types (cont.)



(c): Combination failure of CES+I specimen SQ70 - primarily Type 3



(d): Type 1 and Type 2 failure of NCES specimen SQ57

FIGURE 4: Failure Types

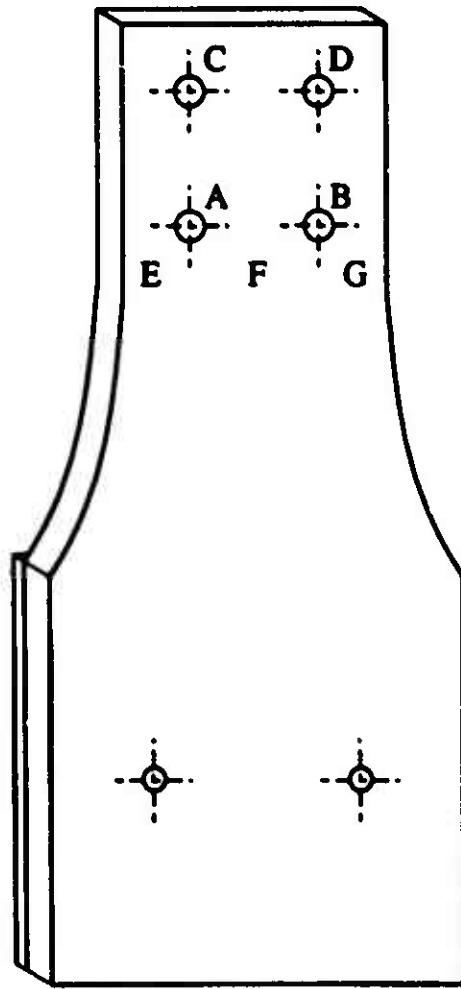
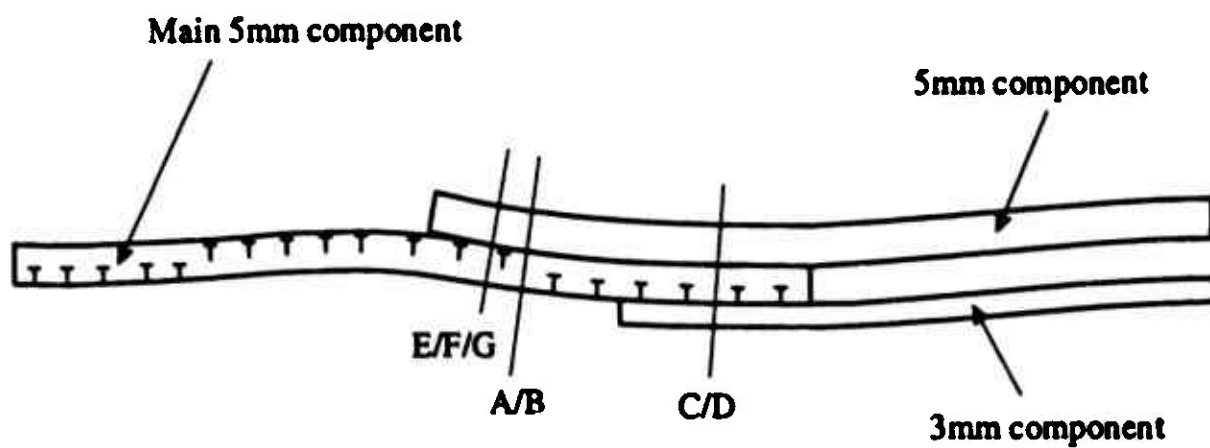

FIGURE 5: Designation of the region of failure



T: Secondary tensile stress

FIGURE 6: Displacement diagram of secondary-bending model
(adapted from [13])

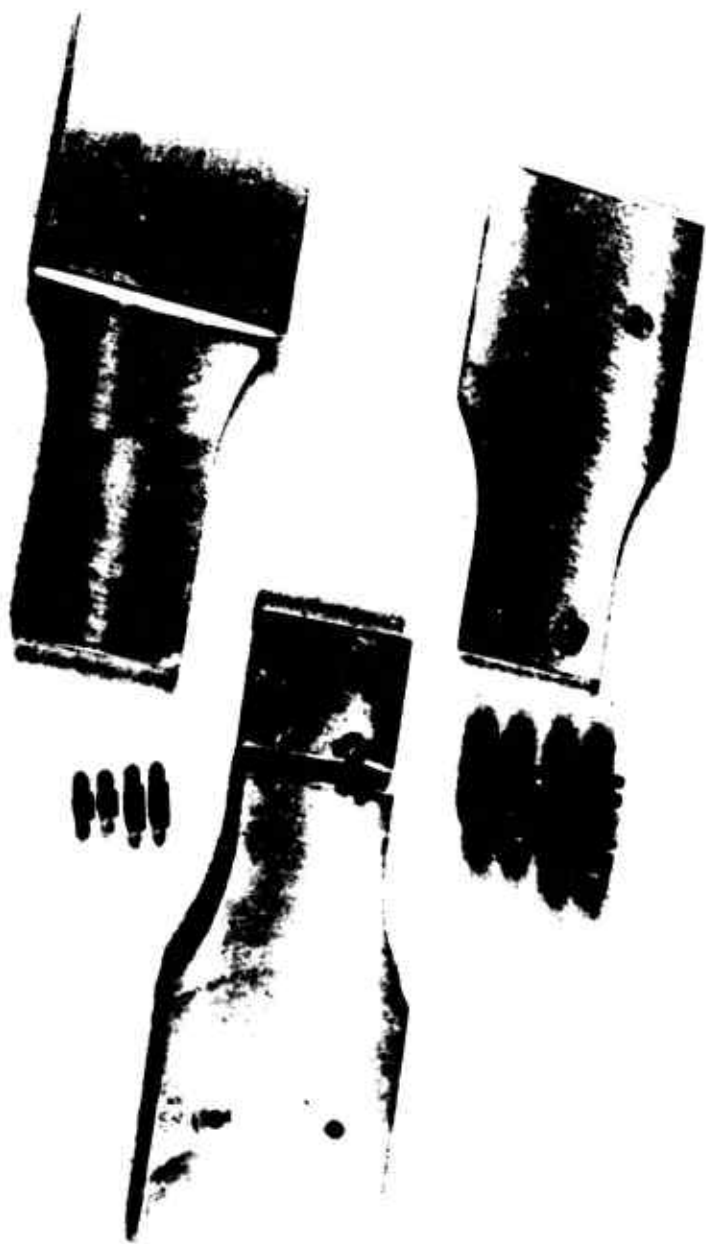

FIGURE 7: Disassembled secondary-bending specimen Q25



FIGURE 8: Fractured main component of specimen Q25

Appendix A: Component List and Assembly Procedure

Non Cold-Expanded Holes with Neat-Fit Bolts and Sealant

- 1 Required components:
 - 3 main members, 5 mm spacer, 2 mm spacer,
 - 2*NAS 464P4-6 and 2*NAS 464P4-11 bolts,
 - 4*MS 21044-N4 nuts, ≈ 20 ¼" flat steel CAD plated washers,
 - 2*7 mm and 2*13 mm 5 mm diameter silver steel dowels,
 - 4*6 mm and 2*5 mm diameter dummy bolts,
 - 4*6.30 mm diameter aligning bolts, 800 grade emery paper,
 - micrometer, 6.31 mm diameter reamer, flat stand, torque wrench,
 - sealant and applicator, lubricant, methylated spirits, ethanol, acetone.
- 2 Pre assembly
 - 2a Wash all 5 plate components with methylated spirits.
 - 2b Assemble as per Figure A1 using 6 mm dummy bolts instead of neat-fit bolts, and 5 mm dummy bolts instead of dowel pins in End 1. End 2 is assembled with dowel pins.
 - 2c Record which components are at End 1 and End 2.
 - 2d Remove dummy-bolt C (as per Figure A1) and ream hole using a lubricant.
 - 2e Record diameter of hole C.
 - 2f Wash hole and aligning bolt with ethanol. Insert aligning bolt into hole C.
 - 2g Use take-up washers, and tighten nut only slightly, to avoid NYLOC being touched.
 - 2h Complete steps 2d to 2g with aligning bolts for holes D, A and B.
- 3 Remove aligning bolt C and polish a P4-11 bolt to a neat fit for hole C (≈6.30 mm). Record bolt diameter and its corresponding position (C) - mark bolt head.
- 4 Repeat step 3 with corresponding neat-fit bolts for holes D, A and B.
- 5 Wash the bolts in ethanol.
- 6 Cover joining areas of test section and 5 mm spacer with (reacted) sealant.
- 7 Assemble specimen, inserting dowel pins in End 1 first.
- 8 Bolt the specimen together with number coded bolts (C, D, A, B) with orientation as per Figure A1.
- 9 Tighten nuts to 10 Nm, using necessary number of washers on both sides.
- 10 Wash off excess sealant with acetone.
- 11 Engrave specimen with its identification number.

Cold-Expanded Holes with Neat-Fit Bolts and Sealant

- 1 Components as for NCES specimens with the addition of:
Mandrel 8-O-N, additional 'nose piece' for expanding gun,
Teflon washer, 4*CBS-8-O-N-23F cold-expansion sleeves.
- 2 Pre assembly steps 2a to 2c as for NCES specimens
 - 2d Remove dummy bolt C (as per Figure A1) and cold-expand hole with mandrel and expanding gun, using teflon washer, cold-expansion sleeves, and slit orientation as per Figure A2. The teflon washer prevents the specimen from being scratched.
 - 2e Ream hole using a lubricant.

Complete as for NCES specimens, steps 2e to 11.

Cold-Expanded Holes with Interference-Fit Bolts and Sealant

- 1 Components as for CES specimens with the addition of:
2*NAS 3004-7 and 2*NAS 3004-11 bolts to replace the P4-6 and P4-11 bolts,
Testing Machine to insert the interference-fit bolts, lubricant (barium chromate),
Plotter.
- 2 Pre assembly as for CES specimens
- 3 Disassemble specimen (except for End 2).
- 4 Record the diameter and position number (C, D, A, B) of the interference-fit bolts. Wash them in ethanol.
- 5 Cover adjoining areas of test section and 5 mm spacer with (reacted) sealant.
- 6 Assemble specimen, inserting dowel pins in End 1 first.
- 7 Bolt the specimen together with aligning bolts in holes D, A and B. Use take-up washers, and tighten nut only slightly, to avoid NYLOC being touched.
- 8 Insert interference-fit bolt C (with orientation as per Figure A1) with testing machine, using a lubricant. Use plotter to record loading.
- 9 Repeat step 8 for bolts D, A and B.

Complete as for NCES specimens, steps 9 to 11.

Non Cold-Expanded Holes with Neat-Fit Bolts

As for NCES specimens, omitting references to sealant. Hence, steps 6 and 10 are disregarded.

Cold-Expanded Holes with Neat-Fit Bolts

As for CES specimens, omitting references to sealant. Hence, steps 6 and 10 (from NCES) are disregarded.

Cold-Expanded Holes with Interference-Fit Bolts

As for CES+I specimens, omitting references to sealant. Hence, step 5, and step 10 (from NCES) are disregarded.

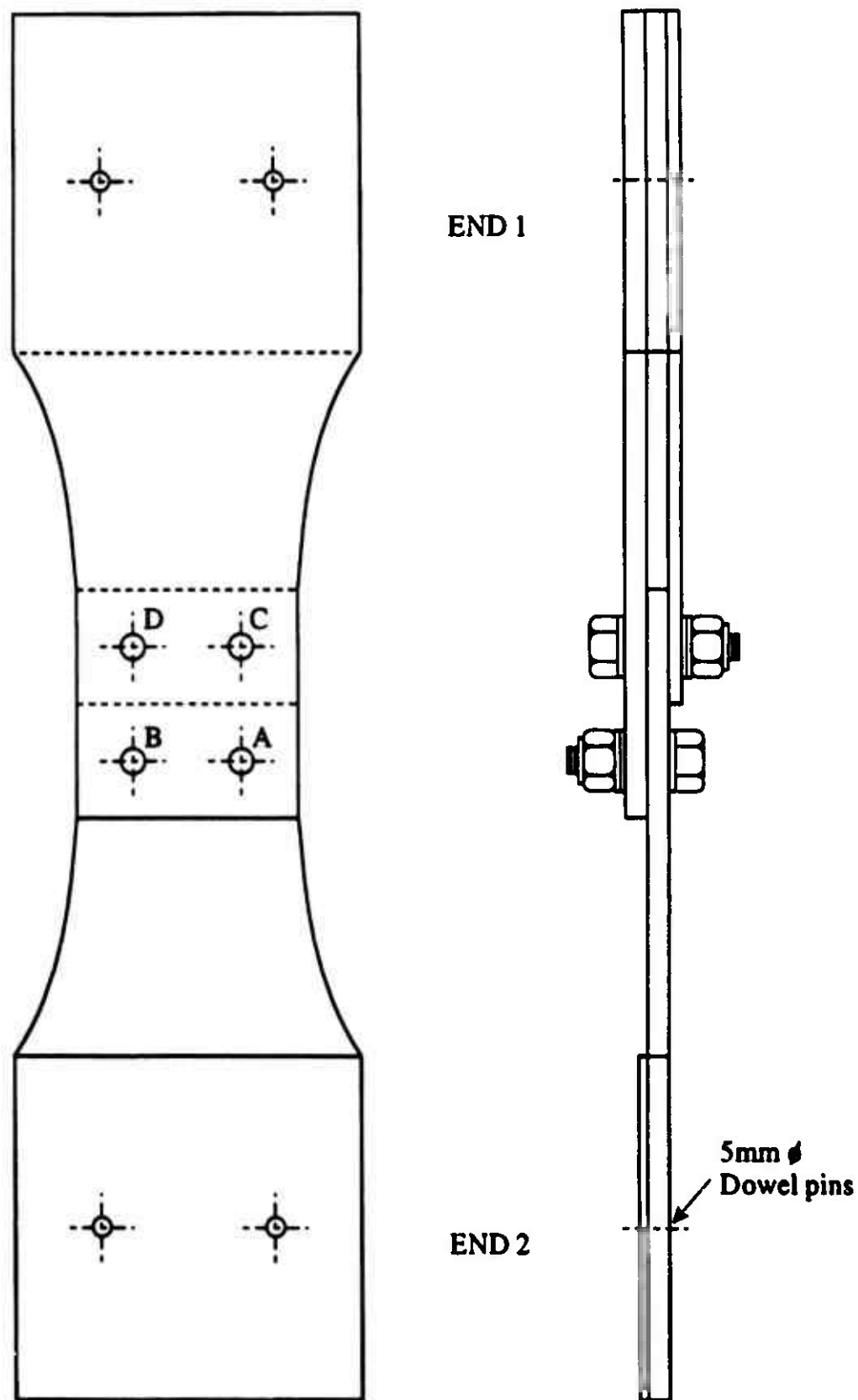

FIGURE A1: Secondary-bending specimen assembly diagram

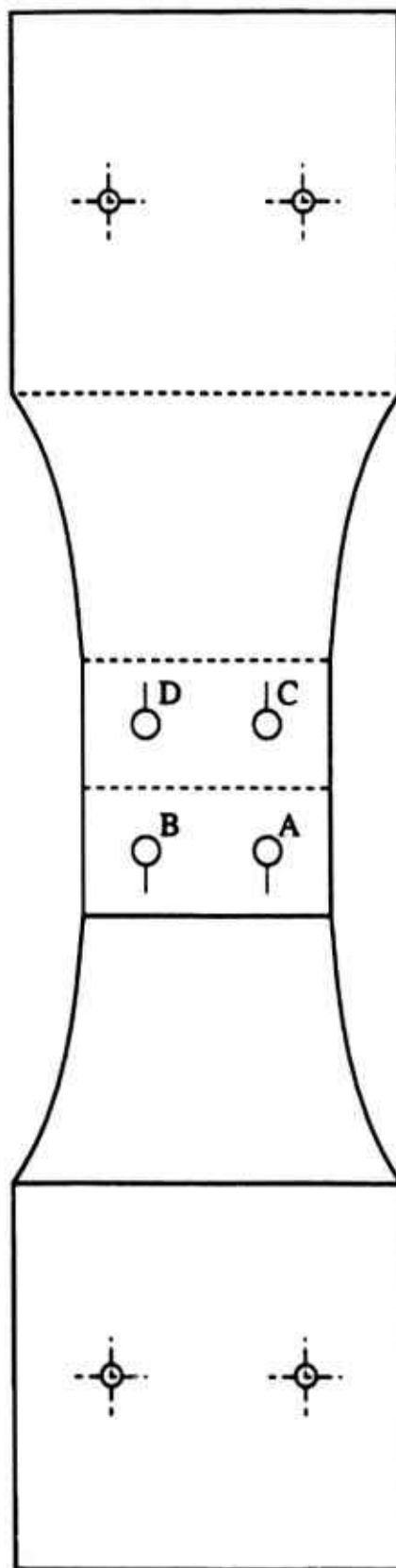

FIGURE A2: Slit orientation for cold-expansion process

Appendix B: Fastener Fits

Fastener Fits of Secondary-Bending Specimens

Both the fastener diameters and hole diameters were measured to determine the fastener fit with results as follows:

		No Sealant	Sealant
Neat Fit	Hole Diameter	6.310 – 6.320 mm	6.310 – 6.320 mm
	Bolt Diameter	6.285 – 6.302 mm	6.285 – 6.31 mm
	Range of Fastener Fit	8 – 35 μm	0 – 35 μm
Neat Fit + Cold Expansion	Hole Diameter	6.310 – 6.320 mm	6.310 – 6.320 mm
	Bolt Diameter	6.290 – 6.303 mm	6.280 – 6.310 mm
	Range of Fastener Fit	7 – 30 μm	0 – 40 μm
Interference Fit + Cold Expansion	Hole Diameter	6.310 – 6.320 mm	6.308 – 6.315 mm
	Bolt Diameter	6.380 mm	6.380 – 6.383 mm
	Range of Fastener Fit	-60 – -70 μm	-65 – -75 μm

DISTRIBUTION

AUSTRALIA

Defence Science and Technology Organisation

Chief Defence Scientist
FAS Science Policy
AS Science Corporate Management } shared copy
Counsellor Defence Science, London (Doc Data Sheet only)
Counsellor Defence Science, Washington (Doc Data Sheet only)
Senior Defence Scientific Adviser (Doc Data Sheet only)
Scientific Advisor Policy and Command (Doc Data Sheet only)
Navy Scientific Adviser (3 copies Doc Data Sheet only)
Scientific Adviser - Army (Doc Data Sheet only)
Air Force Scientific Adviser

Aeronautical Research Laboratory

Director
Library
Chief Airframes and Engines Division
Author: R.L. Evans
J.M. Finney
A.S. Machin
M. Heller
G.S. Jost
C.K. Rider

Materials Research Laboratory
Director/Library

Main Library - DSTO Salisbury

Defence Central

OIC TRS, Defence Central Library
Document Exchange Centre, DSTIC (8 copies)
Defence Intelligence Organisation
Library, Defence Signals Directorate (Doc Data Sheet Only)

HQADF

Director General Force Development (Air)

Air Force

AIRREG4-LC (2 copies)
PDR AF
OIC ATF, ATS, RAAFSTT, WAGGA (2 copies)

Army

Engineering Development Establishment Library
US Army Research, Development and Standardisation Group (3 copies)

Navy

Director Aircraft Engineering - Navy
Director of Naval Architecture

UNIVERSITIES AND COLLEGES

Australian Defence Force Academy
Library
Head of Aerospace and Mechanical Engineering

Melbourne
Engineering Library

Monash
Hargrave Library
Head Materials Engineering
Prof R. Jones, Mechanical Engineering

Newcastle
Professor R. Telfer, Institute of Aviation

Sydney
Engineering Library
Head School of Civil Engineering
Head School of Mechanical & Mechatronic Engineering
Head School of Aeronautical Engineering

NSW
Head, Mechanical Engineering

Tasmania
Engineering Library

Western Australia
Head Mechanical Engineering

RMIT
Library
Mr M.L. Scott, Aerospace Engineering

OTHER GOVERNMENT DEPARTMENTS AND AGENCIES

Department of Transport & Communication, Library
AGPS
SEC of Vic., Herman Research Laboratory
Australian Nuclear Science and Technology Organisation
Civil Aviation Authority

OTHER ORGANISATIONS

NASA (Canberra)
ASTA Engineering, Document Control Office
Ansett Airlines of Australia, Library
Qantas Airways Limited
Hawker de Havilland Aust Pty Ltd, Victoria, Library
Hawker de Havilland Aust Pty Ltd, Bankstown, Library
BHP Melbourne Research Laboratories

CANADA

NRC

J.H. Parkin Branch (Aeronautical & Mechanical Engineering Library)

Universities and Colleges

Toronto

Institute for Aerospace Studies

FRANCE

ONERA

GERMANY

Fachinformationszentrum: Energie, Physik, Mathematik GMBH

INDIA

CAARC Coordinator Structures

National Aeronautical Laboratory, Information Centre

INTERNATIONAL COMMITTEE ON AERONAUTICAL FATIGUE

per Australian ICAF Representative (27 copies)

ISRAEL

Technion-Israel Institute of Technology

JAPAN

National Aerospace Laboratory

National Research Institute for Metals, Fatigue Testing Div.

NETHERLANDS

National Aerospace Laboratory (NLR), Library

NEW ZEALAND

Defence Scientific Establishment, Library

RNZAF

Universities

Canterbury

Library

Head, Mechanical Engineering

SINGAPORE

Director, Defence Materials Organisation

SWEDEN

Aeronautical Research Institute, Library

SWITZERLAND

F+W (Swiss Federal Aircraft Factory)

UNITED KINGDOM

Ministry of Defence, Research, Materials and Collaboration

Defence Research Agency (Aerospace)

Farnborough

Head Materials and Structures

R. Cook Materials and Structures

National Engineering Laboratory, Library

British Library, Document Supply Centre

CAARC Coordinator, Structures

Welding Institute, Library

British Aerospace

Kingston-upon-Thames, Library

Hatfield-Chester Division, Library

Universities and Colleges

Bristol

Engineering Library

Cambridge

Library, Engineering Department

London

Head, Aero Engineering

Manchester

Head, Dept of Engineering (Aeronautical)

Nottingham

Science Library

Southampton

Library

Cranfield Inst. of Technology

Library

Imperial College

Aeronautics Library

UNITED STATES OF AMERICA

NASA Scientific and Technical Information Facility
Boeing Commercial Airplanes
United Technologies Corporation, Library
Lockheed Georgia
Lockheed California Company
McDonnell Aircraft Company, Library

Universities and Colleges

Florida

Aero Engineering Department
Head, Engineering Sciences

Johns Hopkins

Head, Engineering Department

Iowa State

Head, Mechanical Engineering

Princeton

Head, Mechanics Department

Massachusetts Inst. of Technology
MIT Libraries

SPARES (6 COPIES)

TOTAL (142 COPIES)

PAGE CLASSIFICATION
UNCLASSIFIED

PRIVACY MARKING

DOCUMENT CONTROL DATA

1a. AIR NUMBER AR-008-384	1b. ESTABLISHMENT NUMBER ARL-RR-14	2. DOCUMENT DATE AUGUST 1993	3. TASK NUMBER AIR 92/069
4. TITLE THE INFLUENCE OF SECONDARY BENDING ON FATIGUE LIFE IMPROVEMENT IN BOLTED JOINTS		5. SECURITY CLASSIFICATION (PLACE APPROPRIATE CLASSIFICATION IN BOX(S) IE. SECRET (S), CONF. (C), RESTRICTED (R), LIMITED (L), UNCLASSIFIED (U)).	
		6. NO. PAGES 30	
8. AUTHOR(S) R.L. EVANS		9. DOWNGRADING/DELIMITING INSTRUCTIONS Not applicable.	
10. CORPORATE AUTHOR AND ADDRESS AERONAUTICAL RESEARCH LABORATORY AIRFRAMES AND ENGINES DIVISION 506 LORIMER STREET FISHERMENS BEND VIC 3207		11. OFFICE/POSITION RESPONSIBLE FOR RAAF AIRREG4 - LC SPONSOR _____ SECURITY _____ DOWNGRADING _____ APPROVAL _____ CAED	
12. SECONDARY DISTRIBUTION (OF THIS DOCUMENT) Approved for public release. OVERSEAS ENQUIRIES OUTSIDE STATED LIMITATIONS SHOULD BE REFERRED THROUGH DSTIC, ADMINISTRATIVE SERVICES BRANCH, DEPARTMENT OF OFFENCE, ANZAC PARK WEST OFFICES, ACT 2601			
13a. THIS DOCUMENT MAY BE ANNOUNCED IN CATALOGUES AND AWARENESS SERVICES AVAILABLE TO No limitations.			
13b. CITATION FOR OTHER PURPOSES (IE. CASUAL ANNOUNCEMENT) MAY BE <input checked="" type="checkbox"/> UNRESTRICTED OR <input type="checkbox"/> AS FOR 13a.			
14. DESCRIPTORS Bending fatigue Bolted joints Fatigue life		15. DISCAT SUBJECT CATEGORIES 1305	
16. ABSTRACT <i>Secondary bending often occurs in structural joints, and to assess its influence on the fatigue life enhancement technique of hole cold-expansion, an experimental program has been undertaken. The results indicate that the effect of cold working is substantially reduced in specimens with secondary bending. For any marked extension in fatigue life, additional treatments, for example, the combination of cold expansion and interference fit, are required</i>			

PAGE CLASSIFICATION
UNCLASSIFIED

PRIVACY MARKING

THIS PAGE IS TO BE USED TO RECORD INFORMATION WHICH IS REQUIRED BY THE ESTABLISHMENT FOR ITS OWN USE BUT WHICH WILL NOT BE ADDED TO THE DISTIS DATA UNLESS SPECIFICALLY REQUESTED.

16. ABSTRACT (CONT.)

17. IMPRINT

AERONAUTICAL RESEARCH LABORATORY, MELBOURNE

18. DOCUMENT SERIES AND NUMBER

Research Report 14

19. WA NUMBER

21 227C

20. TYPE OF REPORT AND PERIOD COVERED

21. COMPUTER PROGRAMS USED

22. ESTABLISHMENT FILE NO(S)

23. ADDITIONAL INFORMATION (AS REQUIRED)