

2

THE EVALUATION OF TRANSMISSION EFFICIENCY  
AND COUPLING LOSS FACTOR OF STRUCTURAL  
JUNCTIONS

AR-008-252

AD-A272 890  



Y. TSO

MRL-TR-93-1

AUGUST 1993

DTIC  
ELECTE  
NOV 18 1993  
S E D

APPROVED  
FOR PUBLIC RELEASE

 Commonwealth of Australia

MATERIALS RESEARCH LABORATORY

DSTO

THE UNITED STATES NATIONAL  
TECHNICAL INFORMATION SERVICE  
IS AUTHORISED TO  
REPRODUCE AND SELL THIS REPORT

DTIC QUALITY INSPECTED 8

Accession For	
NTIS CRA&I	<input checked="" type="checkbox"/>
DTIC TAB	<input type="checkbox"/>
Unannounced	<input type="checkbox"/>
Justification .....	
By .....	
Distribution /	
Availability Codes	
Dist	Avail and/or Special
A-1	

# The Evaluation of Transmission Efficiency and Coupling Loss Factor of Structural Junctions

Y. Tso

MRL Technical Report  
MRL-TR-93-1

## Abstract

The evaluation of transmission efficiency of structural junctions forms an important part in the study of structure-borne noise as it provides the basis for identifying and quantifying the vibration paths in the structure. In this report, analytical methods for evaluating the transmission efficiency of structural junctions including plate-plate and plate-beam junction are described. The calculation of coupling loss factor from the transmission efficiency of a junction for Statistical Energy Analysis (SEA) is also described. Sample calculations of transmission efficiencies on a number of structural junctions are presented. It is found that for typical naval ship constructions that consist of plates coupled to light thin beams, the elastic vibrations of the beams have a significant effect on the transmission efficiency.

93-28034  
■■■■■■■■■■ 29pg

DEPARTMENT OF DEFENCE  
DSTO MATERIALS RESEARCH LABORATORY

93 11 15 063

*Published by*

*DSTO Materials Research Laboratory  
Cordite Avenue, Maribyrnong  
Victoria, 3032 Australia*

*Telephone: (03) 246 8111  
Fax: (03) 246 8999  
© Commonwealth of Australia 1993  
AR No. 008-252*

**APPROVED FOR PUBLIC RELEASE**

## *Author*



### **Y.K. Tso**

*Yan Tso obtained a BSc degree in mechanical engineering from the Polytechnic of Central London in 1977 and an MSc degree by research from the University of Bath, UK, in 1982. Prior to joining DSTO, he had research experience in the rollover stability and safety aspects of heavy vehicles. He joined MRL in 1991 and is currently working on the applications of Statistical Energy Analysis to structure-borne noise transmission in naval ships.*

---

---

## **Contents**

<b>1. INTRODUCTION</b>	<b>7</b>
<b>2. MODELLING THE STRUCTURAL JUNCTIONS</b>	<b>8</b>
2.1 <i>Mathematical Expression for Vibration Waves</i>	8
2.2 <i>Boundary Conditions</i>	12
2.2.1 <i>Plate-plate Junction</i>	12
2.2.2 <i>Plate-beam Junction (thick beam)</i>	13
2.3 <i>Mathematical Model for a Thin Beam</i>	15
<b>3. TRANSMISSION AND REFLECTION EFFICIENCIES</b>	<b>18</b>
<b>4. COUPLING LOSS FACTOR</b>	<b>19</b>
<b>5. APPLICATIONS TO SHIP STRUCTURAL JUNCTIONS</b>	<b>20</b>
5.1 <i>Plate-Plate Junctions</i>	20
5.2 <i>Plate-Beam Junctions</i>	23
<b>6. CONCLUSIONS</b>	<b>23</b>
<b>7. REFERENCES</b>	<b>25</b>
<b>APPENDIX - List of Symbols</b>	<b>27</b>

# *The Evaluation of Transmission Efficiency and Coupling Loss Factor of Structural Junctions*

## *1. Introduction*

One of the limiting factors in the analysis of vibration transmission through complex structures, such as naval ships, is the transmission across junctions and discontinuities in the structure where vibration waves are partially reflected and partially transmitted. The wave transmission properties of a structural discontinuity may be characterised by the transmission efficiency which is defined as the ratio between the transmitted wave power and the incident wave power. The transmission efficiency is an important parameter in the study of structure-borne noise since it provides the basis to identify and quantify the vibration paths in the structure. This information enables appropriate vibration control techniques to be applied. The transmission efficiency may also be used to calculate the coupling loss factor for Statistical Energy Analysis (SEA). SEA is a very useful technique for analysing the average vibration levels of complex interconnecting elements, such as ship structures, especially at high frequencies.

One of the early attempts to evaluate the transmission efficiency was carried out by Cremer (1948). His work included right-angled plate junctions subjected to oblique incident bending waves. Other authors (Wöhle *et al.*, 1981; Craven and Gibbs, 1981; and Langley and Heron, 1990) have extended the analysis to include longitudinal and transverse shear waves. The contribution of these vibration waves to structure-borne noise has been investigated by Lyon (1986). In the previous studies involving transmission efficiency of plate-beam structures, the stiffening beam was modelled by using conventional beam theory and the effect of beam vibration was neglected. While this so called "blocking mass" approach might be valid for thick heavy beams, there are situations where elastic vibrations of the beam have to be considered. For example, in plate-beam structures typical of ship constructions, the web thickness may be of the same order as the plate and hence the effect of web vibration has to be accounted for in the evaluation of transmission efficiency.

---

In this report, analytical methods for evaluating the transmission efficiency of structural junctions typical of those found in ship constructions are described. The effect of elastic vibrations of the beam in a plate-beam junction is investigated by modelling the beam as a finite plate coupled to a system of semi-infinite plates. Samples of calculations for a number of junctions are presented.

## 2. Modelling the Structural Junctions

### 2.1 Mathematical Expression for Vibration Waves

Figure 1 shows a schematic diagram of plate-plate junction which consists of  $n$  plates coupled along a line. The plates are assumed to be infinite along the  $y$  and  $x_1$  to  $x_n$  directions. It is further assumed that the plates are thin so that the boundary conditions can be applied on the plate centreline. Plate 1 is subjected to an oblique incident wave which can be either bending ( $B$ ), longitudinal ( $L$ ) or transverse shear ( $T$ ). The incident wave is partially reflected and partially transmitted at the junction as bending, longitudinal and transverse shear waves as shown. To study the mechanism of wave transmission at a junction, it is convenient, as a first step, to consider the elastic deformations due to these reflected or transmitted waves in an arbitrary plate. Figure 2 shows the plate deformations  $u$ ,  $v$  and  $w$  along a set of local co-ordinates  $x$ ,  $y$  and  $z$  respectively. Using thin isotropic plate theory, the following governing equations of motion for plate deformations may be derived (see Love, 1927, p496).

The bending wave equation being:

$$\nabla^4 w + [12\rho(1-\mu^2)/Eh^2] \partial^2 w / \partial t^2 = 0, \quad (1)$$

and the in-plane wave equations are:

$$\partial^2 u / \partial x^2 + [(1-\mu)/2] \partial^2 u / \partial y^2 + [(1+\mu)/2] \partial^2 v / \partial x \partial y - [\rho(1-\mu^2)/E] \partial^2 v / \partial t^2 = 0, \quad (2)$$

$$\partial^2 v / \partial y^2 + [(1-\mu)/2] \partial^2 v / \partial x^2 + [(1+\mu)/2] \partial^2 u / \partial x \partial y - [\rho(1-\mu^2)/E] \partial^2 u / \partial t^2 = 0, \quad (3)$$

where  $\nabla^4 = [\partial^2 / \partial x^2 + \partial^2 / \partial y^2]^2$ ,

- $\rho$  = material density,
- $\mu$  = Poisson's ratio,
- $h$  = plate thickness,
- $E$  = Young's modulus.



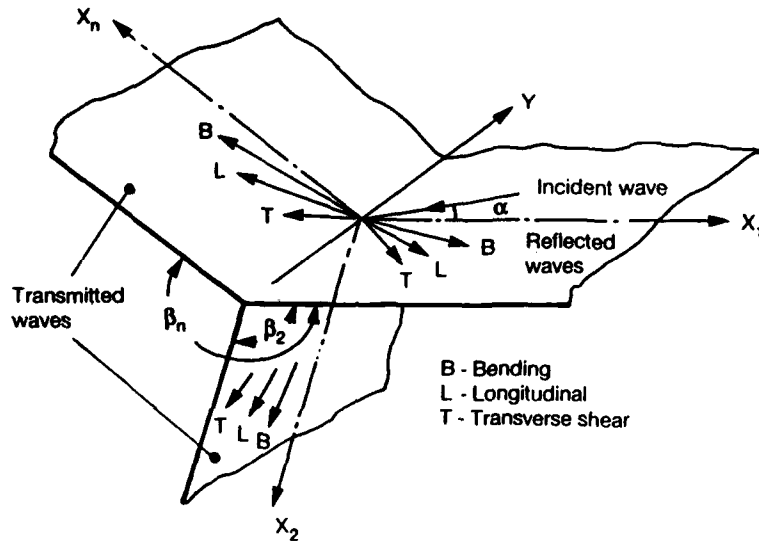

**Figure 1:** Schematic diagram of a plate-plate junction.

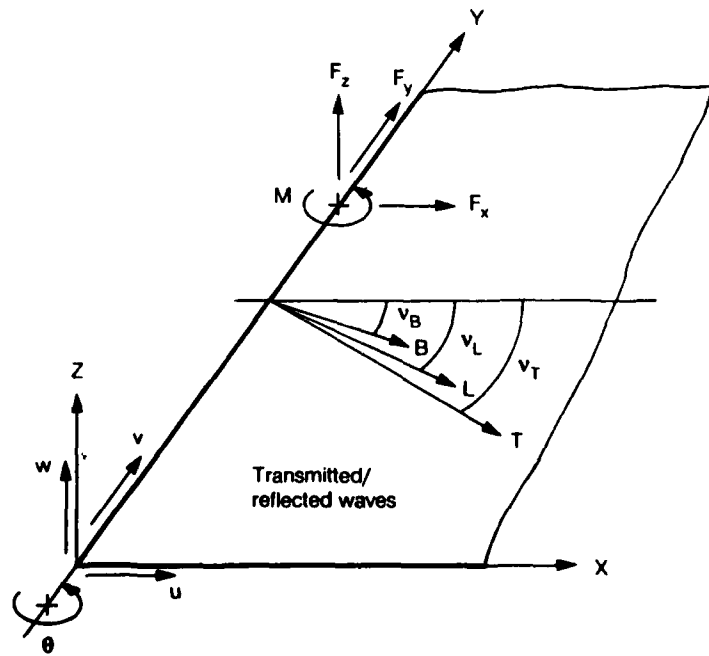

**Figure 2:** Co-ordinate system of an arbitrary plate showing transmitted/reflected waves, plate displacements and junction forces and moment.

The in-plane wave equations are functions of the plate deformations  $u$  and  $v$ . To obtain a solution for these equations, one can make use of the velocity potential  $\phi$  and stream function  $\psi$  defined as follows (a detailed discussion on the use of velocity potential and stream function to analyse vibration waves is given by Cremer *et al.*, 1988, p 138):

$$u = -\partial\phi / \partial x - \partial\psi / \partial y, \quad (4)$$

$$v = -\partial\phi / \partial y + \partial\psi / \partial x. \quad (5)$$

Using equations (4) and (5), each of the in-plane wave equations is reduced to a function of one dependent variable ( $\phi$  or  $\psi$ ) only:

$$\nabla^2\phi - [\rho(1-\mu^2)/E]\partial^2\phi / \partial t^2 = 0, \quad (6)$$

$$\nabla^2\psi - [2\rho(1+\mu)/E]\partial^2\psi / \partial t^2 = 0. \quad (7)$$

The general solutions to equations (1), (6) and (7) may be expressed as:

$$w = W \exp(k_{Bx}x + k_{By}y + j\omega t), \quad (8)$$

$$\phi = \Phi \exp(k_{Lx}x + k_{Ly}y + j\omega t), \quad (9)$$

$$\psi = \Psi \exp(k_{Tx}x + k_{Ty}y + j\omega t). \quad (10)$$

The velocity potential  $\phi$  is associated with longitudinal waves while the stream function  $\psi$  with transverse shear waves. For the solutions to be valid, the following conditions must be satisfied (these conditions can be obtained by substituting equations (8), (9) and (10) into equations (1), (6) and (7) respectively):

$$-(k_{Bx}^2 + k_{By}^2) = \pm [12\rho\omega^2(1-\mu^2)/Eh^2]^{1/2} = \pm k_B^2, \quad (11)$$

$$-(k_{Lx}^2 + k_{Ly}^2) = [\rho\omega^2(1-\mu^2)/E] = k_L^2, \quad (12)$$

$$-(k_{Tx}^2 + k_{Ty}^2) = [2\rho\omega^2(1+\mu)/E] = k_T^2, \quad (13)$$

where  $k_B$ ,  $k_L$  and  $k_T$  are the bending, longitudinal and transverse shear wave numbers respectively. Snell's law states that the trace velocity of all wave types at the junction must be the same. This implies that the  $y$ -component of wave numbers (i.e.  $k_{By}$ ,  $k_{Ly}$  and  $k_{Ty}$ ) for the reflected and transmitted waves of all plates must be the same as that of the incident wave. The  $x$ -component of wave numbers may be determined from equations (11) - (13). For bending waves, equation (11) yields four roots, the negative imaginary root and the negative real root must be selected since they represent propagating and decaying waves respectively in the positive  $x$ -direction (i.e. away from the junction). Similarly, the solutions for longitudinal and transverse shear waves must be negative imaginary. Equations (4), (5) and (8)-(10) give the elastic deformations of the plate,  $u$ ,  $v$  and  $w$ . By expressing the  $x$  and  $y$ -components of wave numbers in terms of the reflection/transmission angles  $\gamma_B$ ,  $\gamma_L$  and  $\gamma_T$ , the plate deformations may be written as:

$$u = [jk_L \Phi \cos \gamma_L \exp(-jk_L x \cos \gamma_L) - jk_T \Psi \sin \gamma_T \exp(-jk_T x \cos \gamma_T)] \exp(k_y y + j\omega t), \quad (14)$$

$$v = [-jk_L \Phi \sin \gamma_L \exp(-jk_L x \cos \gamma_L) - jk_T \Psi \cos \gamma_T \exp(-jk_T x \cos \gamma_T)] \exp(k_y y + j\omega t), \quad (15)$$

$$w = [W_1 \exp(-jk_B x \cos \gamma_B) + W_2 \exp[-k_B x \sqrt{(1 + \sin^2 \gamma_B)}]] \exp(k_y y + j\omega t), \quad (16)$$

where  $k_y$  is the  $y$  - component of incident wave number. The last exponential factor on the right hand side of the above equations represents the  $y$  - direction dependency and time dependency of the displacement amplitudes. These factors are exactly the same for all wave types and will be omitted in the subsequent expressions for simplicity. The reflection/transmission angles may be expressed in terms of the incident angle using the Snell's law as discussed earlier:

$$k_B \sin \gamma_B = k_L \sin \gamma_L = k_T \sin \gamma_T = k \sin \alpha, \quad (17)$$

where  $\alpha$  is the incident angle and  $k$  is the incident wave number. Note that the incident wave can be either bending, longitudinal or transverse shear. Equations (14) - (16) can be further simplified by introducing the complex wave displacement amplitudes defined as follows:

$$\xi_B = W_1, \quad \xi_{BN} = W_2, \quad (18), (19)$$

$$\xi_L = jk_L \Phi, \quad \xi_T = jk_T \Psi, \quad (20), (21)$$

$\xi_B$  and  $\xi_{BN}$  represents the complex wave amplitudes of the travelling and decaying bending waves respectively while  $\xi_L$  and  $\xi_T$  denote the amplitudes of the longitudinal and transverse shear waves. Using equations (17) - (21), the plate deformations may be expressed as:

$$u = \xi_L [R_L / (k_L / k)] \exp(-jkR_L x) - \xi_T [\sin \alpha / (k_T / k)] \exp(-jkR_T x), \quad (22)$$

$$v = -\xi_L [\sin \alpha / (k_L / k)] \exp(-jkR_L x) - \xi_T [R_T / (k_T / k)] \exp(-jkR_T x), \quad (23)$$

$$w = \xi_B \exp(-jkR_B x) + \xi_{BN} \exp(-kR_{BN} x), \quad (24)$$

$$\text{where } R_D = \sqrt{(k_D/k)^2 - \sin^2 \alpha}, \quad (25)$$

$D = B, L$  or  $T$  depending on the wave type,

$$R_{BN} = \sqrt{(k_B / k)^2 + \sin^2 \alpha}. \quad (26)$$

In equation (25), if the quantity inside the square root is negative, the exponential term representing the travelling wave in the wave equations becomes a real quantity and wave propagation cannot exist. One must then replace the quantity

$\sqrt{[(k_D/k)^2 - \sin^2 \alpha]}$  by  $-j\sqrt{[\sin^2 \alpha - (k_D/k)^2]}$  in the solution of wave amplitudes. For plate 1, the deformations must also include the components of incident wave. The elastic deformations due to the incident wave may be obtained in a similar manner as that of the reflected/transmitted waves. The only difference being that the positive imaginary solution of the wave numbers in equations (11) - (13) must be selected since the incident wave propagates towards the junction. For the purpose of evaluating the transmission efficiency, the incident wave may be considered as having a unit amplitude. Hence, for an incident bending wave, the elastic deformation is:

$$w^B = \exp(j k_B x \cos \alpha), \quad (27)$$

for a longitudinal wave,

$$u^L = -\cos \alpha [\exp(j k_L x \cos \alpha)], \quad (28)$$

$$v^L = -\sin \alpha [\exp(j k_L x \cos \alpha)], \quad (29)$$

and for a transverse shear wave,

$$u^T = -\sin \alpha [\exp(j k_T x \cos \alpha)], \quad (30)$$

$$v^T = \cos \alpha [\exp(j k_T x \cos \alpha)]. \quad (31)$$

Superscripts  $B$ ,  $L$  and  $T$  denote the type of incident wave. It follows from the above analysis that the elastic deformations of each plate in the junction are expressed in terms of four unknowns representing the complex wave amplitudes, namely, the amplitudes for longitudinal and transverse shear waves, as well as the travelling and decaying bending waves. Hence, in a junction that consists of  $n$  coupled plates, there are  $4n$  unknowns to describe the wave motion. These unknowns may be solved by the appropriate boundary conditions.

## 2.2 Boundary conditions

### 2.2.1 Plate-plate junction

To consider the boundary conditions at a junction, it is convenient to introduce the subscript  $i$  to denote the plate number ( $i = 1, 2, \dots, n$ ). The compatibility of plate motions requires that the displacement components of all plates along a set of reference co-ordinates (e.g.  $x_1$ ,  $y$  and  $z_1$ ) at the junction must be the same. In addition, the rotation about the  $y$  axis of all plates should be equal. The plate rotation is given by:

$$\theta_i = \partial w_i / \partial x_i, \quad (32)$$

The displacement components of all plates ( $u_i$ ,  $v_i$  and  $w_i$ ) due to bending, longitudinal and transverse shear waves are given by equations (22) - (24). For plate 1, the displacements must also include components of the appropriate incident wave as given by equations (27) - (31). Resolving the displacements of

plate 1 along co-ordinates  $x$ ,  $y$  and  $z$ , leads to the following compatibility equation:

$$\begin{matrix} n \\ \left. \begin{matrix} u_i \\ v_i \\ w_i \\ \theta_i \end{matrix} \right|_{i=2} = \left. \begin{matrix} \cos \beta_i, & 0, & -\sin \beta_i, & 0 \\ 0, & 1, & 0, & 0 \\ \sin \beta_i, & 0, & \cos \beta_i, & 0 \\ 0, & 0, & 0, & 1 \end{matrix} \right| \left. \begin{matrix} u_1 \\ v_1 \\ w_1 \\ \theta_1 \end{matrix} \right|, \quad (33) \end{matrix}$$

where  $\beta_i$  = angle between plate  $i$  and plate 1.

For thin isotropic plates, the forces and moment per unit length of plate (along the  $y$  - direction) may be expressed as (see Leissa, 1969, p 336):

$$F_{xi} = -[E_i h_i / (1 - \mu_i^2)] [\partial u_i / \partial x_i + \mu_i \partial v_i / \partial y], \quad (34)$$

$$F_{yi} = -[E_i h_i / 2(1 + \mu_i)] [\partial u_i / \partial y + \partial v_i / \partial x_i], \quad (35)$$

$$F_{zi} = [E_i h_i^3 / 12(1 - \mu_i^2)] [\partial^3 w_i / \partial x_i^3 + (2 - \mu_i) \partial^3 w_i / \partial x_i \partial y^2], \quad (36)$$

$$M_i = -[E_i h_i^3 / 12(1 - \mu_i^2)] [\partial^2 w_i / \partial x_i^2 + \mu_i \partial^2 w_i / \partial y^2]. \quad (37)$$

Note that equation (36) represents the effective edge force which consists of the shear force plus the effect of twisting moment (see Leissa, 1969, p 338 and Cremer *et al.*, 1988, p 435 for details). Using equations (34) - (37), the forces and moments of the plates can be obtained. Equilibrium requirements for the balance of forces and moments at the plate junction lead to the following equation:

$$F_{x1} + \sum_{i=2}^n F_{xi} \cos \beta_i + \sum_{i=2}^n F_{zi} \sin \beta_i = 0, \quad (38)$$

$$\sum_{i=1}^n F_{yi} = 0 \quad (39)$$

$$F_{z1} - \sum_{i=2}^n F_{xi} \sin \beta_i + \sum_{i=2}^n F_{zi} \cos \beta_i = 0, \quad (40)$$

$$\sum_{i=1}^n M_i = 0. \quad (41)$$

Equations (33) and (38) - (41) provide the necessary boundary conditions for the solution of wave amplitudes. These equations are evaluated at the origin of the co-ordinate system (i.e.,  $x_1, x_2, x_3, \dots = 0$ ). A standard computer routine which handles a system of linear equations with complex coefficients may be used.

### 2.2.2 Plate-beam junction (thick beam)

Figure 3 shows a schematic diagram of an infinite plate coupled to a thick uniform beam. The thick beam assumption in the context of this report implies that no incident wave is transmitted to the beam. Also, it is assumed that the beam centroid coincides with the shear centre and  $x_b$  is a principal axis. It is further assumed that the boundary conditions can be applied to the origin of the co-ordinate system (the validity of this assumption is discussed in section 5.2). Thus, the compatibility requirements for plate motions in this case are exactly the same as for a plate-plate junction (equation (33)). However, the force and moment balance equations ((38) - (41)) must be modified to allow for the torsional, bending and inertia effects of the beam. For beams of high slenderness ratio (defined as the ratio between the length and radius of gyration), the effects of shear deformation and rotary inertia may be neglected (these effects have been investigated by Langley and Heron, 1990) and the forces and moment balance equations may be derived by the conventional beam theory.

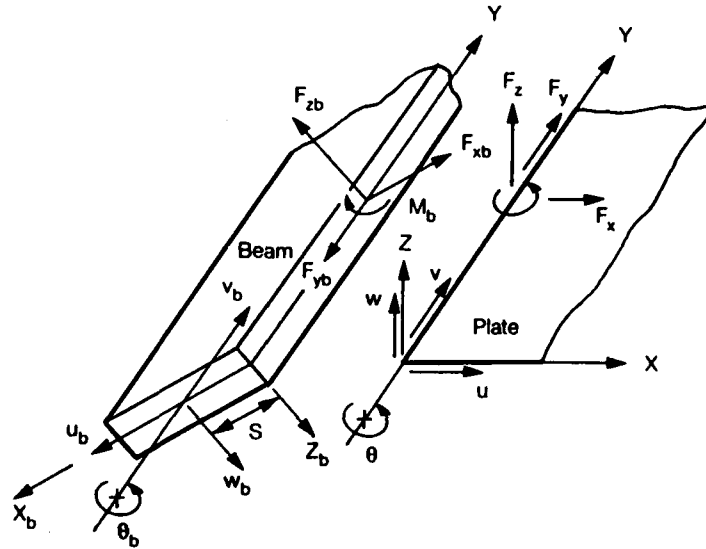

Figure 3: A plate - thick beam junction showing the displacements and junction forces and moments.

At the junction, the sum of the forces and moments due to all plates may be resolved along the beam co-ordinates  $x_b$ ,  $y_b$ ,  $z_b$  and expressed as the beam forces and moment (see Figure 3):

$$F_{xb} = F_{x1} \cos \beta_b - F_{z1} \sin \beta_b + \sum_{i=2}^n F_{xi} \cos(\beta_i - \beta_b) + \sum_{i=2}^n F_{zi} \sin(\beta_i - \beta_b), \quad (42)$$

$$F_{yb} = \sum_{i=1}^n F_{yi}, \quad (43)$$

$$F_{zb} = F_{z1} \sin \beta_b + F_{z1} \cos \beta_b - \sum_{i=2}^n F_{z1} \sin(\beta_i - \beta_b) + \sum_{i=2}^n F_{zi} \cos(\beta_i - \beta_b), \quad (44)$$

$$M_b = \sum_{i=1}^n M_i. \quad (45)$$

The motions about the beam centroid  $u_b$ ,  $v_b$ ,  $w_b$ , and  $\theta_b$  may be expressed in terms of the elastic deformations of plate 1:

$$u_b = u_1 \cos \beta_b - w_1 \sin \beta_b \quad (46)$$

$$v_b = v_1, \quad (47)$$

$$w_b = u_1 \sin \beta_b + w_1 \cos \beta_b + \theta_1 S, \quad (48)$$

$$\theta_b = \theta_1, \quad (49)$$

where  $\beta_b$  = angle between the beam and plate 1,  
 $S$  = distance between beam centroid and the junction.

The equilibrium of forces and moments at the junction must allow for the torsional, bending and inertia effects of the beam. Consider the balance of forces in the  $x_b$  direction, the beam force  $F_{xb}$  is augmented by the shear force as a result of beam bending in the  $x_b$ - $y$  plane (a similar argument exists for forces in the  $z_b$  direction). Summation of forces along the beam co-ordinates leads to the following force balance equations:

$$-F_{xb} - E_b I_{zb} \partial^4 u_b / \partial y^4 = m_b \partial^2 u_b / \partial t^2, \quad (50)$$

$$-F_{yb} = m_b \partial^2 v_b / \partial t^2, \quad (51)$$

$$-F_{zb} - E_b I_{xb} \partial^4 w_b / \partial y^4 = m_b \partial^2 w_b / \partial t^2, \quad (52)$$

where  $m_b$  = mass per unit length of beam,  
 $E_b$  = Young's modulus of beam,  
 $I_{xb}$  = second moment of area of beam about axis  $x_b$ ,  
 $I_{zb}$  = second moment of area of beam about an axis parallel to  $z_b$  and passes through the beam centroid.

The variation in plate rotation  $\theta_1$  along the  $y$  - axis causes the beam to twist and results in a torsional moment. Consider the equilibrium of moments about a line parallel to the  $y$  - axis and passes through the beam centroid:

$$-M_b + F_{zb} S + T_b \partial^2 \theta_b / \partial y^2 = J_b \partial^2 \theta_b / \partial t^2, \quad (53)$$

where  $T_b$  = torsional stiffness of the beam,  
 $J_b$  = moment of inertia per unit length about beam centroid.

Equations (33) and (50) - (53) represent the boundary conditions for a system of plates coupled with a thick beam. Again, these are sufficient to permit solution for the wave amplitudes of interest.

### 2.3 Mathematical Model for a Thin Beam

Some engineering structures (e.g. ships, aircraft) quite often involve the use of thin beams to reinforce plate elements. A thin beam in the context of this paper implies that the beam thickness is of the same order as that of the plate element and is therefore subjected to bending and in-plane waves. A schematic diagram of the structure is shown in Figure 4. The analysis of this type of structures may be carried out by assuming that the thin beam behaves as a finite plate with waves travelling in both the positive and negative  $x$  - directions. Referring back to equations (11) - (13), the solutions to wave motions of the finite plate in this case must include the positive and negative roots. This results in eight unknown complex wave amplitudes (instead of four unknowns as in the case of an infinite plate). By denoting the web as the second plate in a plate-plate junction, the expressions for bending and in-plane waves may be derived in a procedure similar to those described in section 2.1:

$$u_2 = [R_{L2} / (k_{L2} / k)] \{ \xi_{L2} \exp(-jkR_{L2}x_2) - \xi'_{L2} \exp(jkR_{L2}x_2) \} - [\sin \alpha / (k_{T2} / k)] \{ \xi_{T2} \exp(-jkR_{T2}x_2) + \xi'_{T2} \exp(jkR_{T2}x_2) \}, \quad (54)$$

$$v_2 = -[\sin \alpha / (k_{L2} / k)] \{ \xi_{L2} \exp(-jkR_{L2}x_2) + \xi'_{L2} \exp(jkR_{L2}x_2) \} - [R_{T2} / (k_{T2} / k)] \{ \xi_{T2} \exp(-jkR_{T2}x_2) - \xi'_{T2} \exp(jkR_{T2}x_2) \}, \quad (55)$$

$$w_2 = \xi_{B2} \exp(-jkR_{B2}x_2) + \xi_{BN2} \exp(-kR_{BN2}x_2) + \xi'_{B2} \exp(jkR_{B2}x_2) + \xi'_{BN2} \exp(kR_{BN2}x_2). \quad (56)$$

The additional four unknowns in a plate - thin beam junction  $\xi'_{B2}$ ,  $\xi'_{BN2}$ ,  $\xi'_{L2}$  and  $\xi'_{T2}$  represent waves that travel in the negative  $x_2$  - direction of the finite plate. Four additional boundary conditions are thus required to solve the wave motions. These boundary conditions may be obtained by considering the force and moment balance at the end of the finite plate. Substituting equations (54) - (56) into (34) - (37) and evaluating these equations at  $x_x = L_w$  gives the forces and moment. For the structural junction shown in Figure 4, the forces and moment must vanish at the free end of the plate.

Figure 5 shows a typical reinforced plate structure used in naval ship constructions. The stiffening beam in this case consists of a web and flange. For the analysis of vibration transmission, the flange may be considered as another finite plate attached to the web and the flange with the web junction analysed using a similar procedure as previously described. Alternatively, if the flange is thick compared with the web (say, or the order of twice the web thickness), one may assume that the flange behaves as a thick beam attached to the web and the analysis carried out in a procedure similar to those described in section 2.2.2. Figure 6 shows the forces and moments at the flange - web junction. The force and moment balance equations (evaluated at  $x_2 = L_w$ ) may be expressed as:



$$F_{x2} = m_f \partial^2 u_2 / \partial t^2, \quad (57)$$

$$F_{y2} = m_f \partial^2 v_2 / \partial t^2, \quad (58)$$

$$F_{z2} - \partial F_{zf} / \partial y = m_f \partial^2 w_2 / \partial t^2, \quad (59)$$

$$M_2 + \partial M_f / \partial y = I_f \partial^2 \theta_2 / \partial t^2, \quad (60)$$

where subscript  $f$  represents the flange, and

$$\partial F_{zf} / \partial y = E_f I_f \partial^4 w_2 / \partial y^4,$$

$$\partial M_f / \partial y = T_f \partial^2 \theta_2 / \partial y^2.$$

Equations (57) - (60) represents the additional boundary conditions for the solution of wave amplitudes.

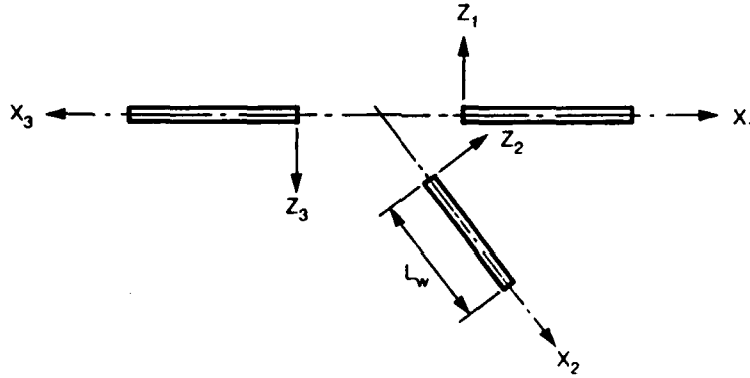

Figure 4: Schematic diagram of a plate - thin beam junction.

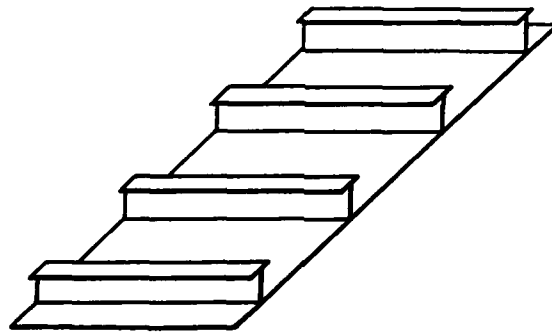

Figure 5: Periodically stiffened panel.

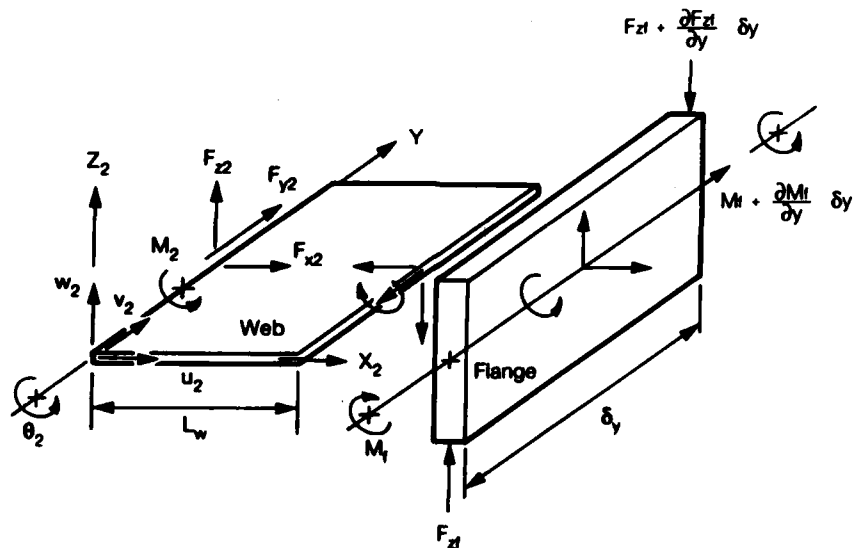

Figure 6: A flange - web junction showing displacements, forces and moments.

### 3. Transmission and Reflection Efficiencies

The above analysis solves the wave amplitudes of plate - plate and plate - beam junctions and leads to the calculation of wave power. The wave power per unit length of a junction subjected to normal waves (perpendicular to the junction) may be expressed as the energy per unit area multiplied by the group velocity (see Cremer *et al.*, 1988 p 109). For oblique waves, the expression must be modified by multiplying it with the cosine of the wave angle since it is the projected length of the boundary line that effectively intercepts the wave. Figure 7 shows the interception of an oblique incident wave for a plate - plate junction. Recall that the incident wave has a unit amplitude, the power due to an incident wave at an angle  $\alpha$  is given by:

$$P_{INC} = m_1 \omega^2 c_{g1} \cos \alpha. \quad (61)$$

Similarly, the transmitted/reflected power may be expressed as:

$$P_{Di} = m_i |\xi_{Di}|^2 \omega^2 c_{gi} \cos \gamma_{Di}. \quad (62)$$

The transmission/reflection angle  $\gamma_{Di}$  may be expressed in terms of the incident angle  $\alpha$  using Snell's law (equation (17)). The power expression thus becomes:

$$P_{Di} = m_i |\xi_{Di}|^2 \omega^2 c_{gi} (k/k_{Di}) \text{Re}[k_{Di}/k - \sin^2 \alpha], \quad (63)$$

- where  $m_i$  = mass per unit area of plate  $i$ ,  
 $D$  =  $B$ ,  $L$  or  $T$  depending on the wave type,  
 $c_{gi}$  = group velocity of plate  $i$ ,  
=  $2 c_{Bi}$  for bending waves,  
=  $c_{Li}$  for longitudinal waves,  
=  $c_{Ti}$  for transverse shear waves.

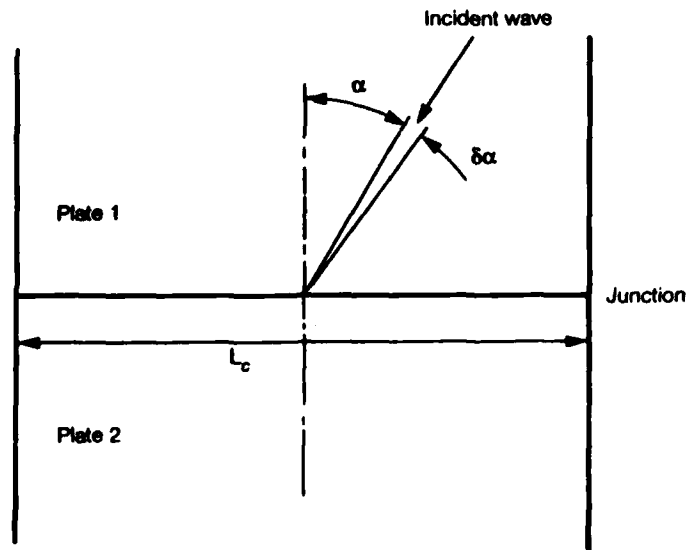

Figure 7: Interception of an oblique incident wave at a junction.

Note that for bending waves, the transmitted or reflected power in a plate is determined by the far field travelling waves only. The near field waves decay exponentially along the direction  $x_i$  and carry no time averaged power. Also, no power is transmitted by a finite plate.

The transmission/reflection efficiency is defined as the ratio of the transmitted/reflected wave power to the incident wave power and is a function of the incident angle  $\alpha$ :

$$r_i^q(\alpha) = P_{D_i} / P_{INC} \quad (64)$$

where  $q$  and  $r$  represent the wave type of the incident and generated waves respectively, and  $i$  represents the carrier plate of the generated waves. Conservation of energy requires that the sum of all transmission and reflection efficiencies to be equal to one.

#### 4. Coupling Loss Factor

The coupling loss factor used in SEA defines the amount of energy flow from one element to the other. It can be shown (Lyon, 1975, p 91) that for two coupled sub-systems, the power lost by sub-system 1 due to coupling to sub-system 2 is proportional to the energy of sub-system 1 and may be expressed in terms of the coupling loss factor as follows:

$$P_{12} = \omega \eta_{12} \langle E_1 \rangle \quad (65)$$

where  $\langle E_1 \rangle$  = time averaged energy of sub-system 1,  
 $\eta_{12}$  = coupling loss factor between sub-systems 1 and 2.

Consider an SEA system that consists of two coupled plates as shown in Figure 7. If plate 1 carries a diffuse vibration field incident on the junction, the total power transmitted to plate 2 can be obtained by multiplying the power of plate 1 with the transmission efficiency and then average the results over the entire range of incident angles (see Cremer *et al.*, 1988, p. 426):

$$\begin{aligned}
 P_{12} &= (c_{g1} L_c \langle E_1 \rangle / A_1 2\pi) \int_{-\pi/2}^{\pi/2} \tau_2^{\sigma}(\alpha) \cos \alpha d\alpha, \\
 &= (c_{g1} L_c \langle E_1 \rangle / A_1 \pi) \int_0^1 \tau_2^{\sigma}(\alpha) d(\sin \alpha), \\
 &= (c_{g1} L_c \langle E_1 \rangle / A_1 \pi) \tau_m,
 \end{aligned} \tag{66}$$

where  $L_c$  = coupling line length,  
 $\tau_m$  = mean transmission efficiency,  
 $A_1$  = area of plate 1.

From equations (65) and (66), the coupling loss factor between two coupled plates is given by:

$$\eta_{12} = (c_{g1} L_c / \omega \pi A_1) \tau_m, \tag{67}$$

From the above considerations on coupling loss factor, it is evident that the mean transmission efficiency  $\tau_m$  is a useful parameter for characterising the wave transmission properties of a junction subjected to an incident diffuse vibration field. The mean transmission efficiency may be obtained by a numerical integration procedure and incorporated into a computer program. The sample calculations presented in the following section are based on mean transmission efficiencies.

## 5. Applications to Ship Structural Junctions

### 5.1 Plate-Plate Junctions

Figure 8 shows a schematic diagram of a section of ship's structure which mainly consists of plate joints. The mean transmission efficiencies for junctions A, B and C were calculated by the mathematical model described in Section 2.2.1 and are plotted in Figures 9, 10 and 11 respectively. In all three cases studied, it can be seen that the significance of in-plane vibration in wave transmission increases with frequency. For example, at 8000 Hz, about 10-15% of the incident wave power is transmitted by in-plane vibration. Although in-plane motions are not coupled efficiently to the sound field, they may propagate through the structure and transform into bending motions at a structural discontinuity. Hence in-plane motions may be considered as a flanking path to bending motions and, if that flanking path is ignored in the analysis, the results may lead to an underestimation of the transmitted structure-borne noise.

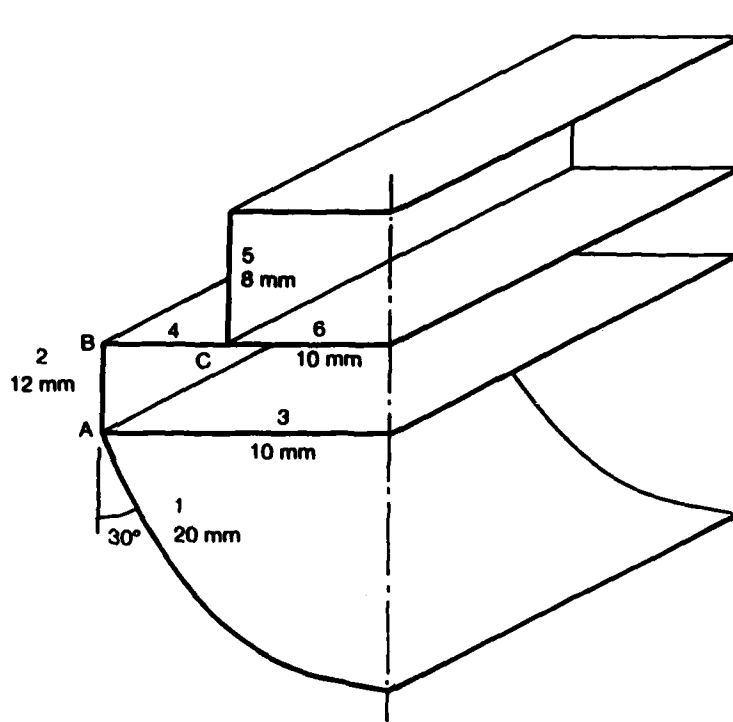

Figure 8: Schematic diagram of a ship's section.

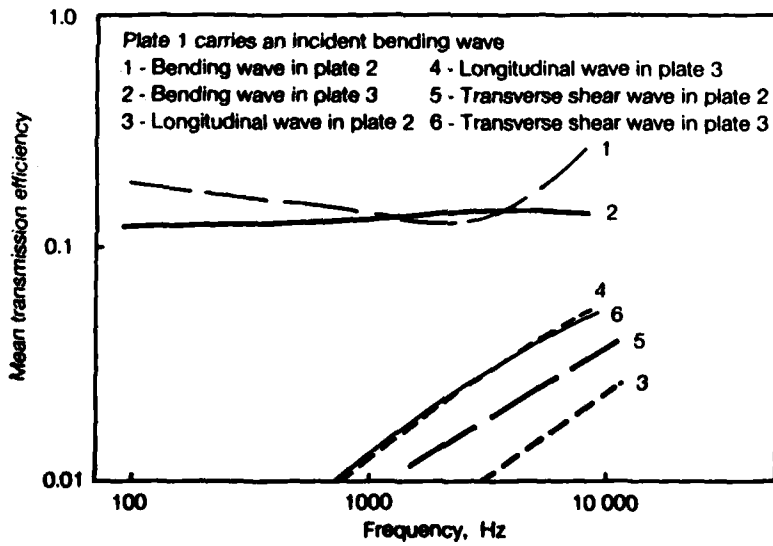

Figure 9: Wave power transmission for junction A.

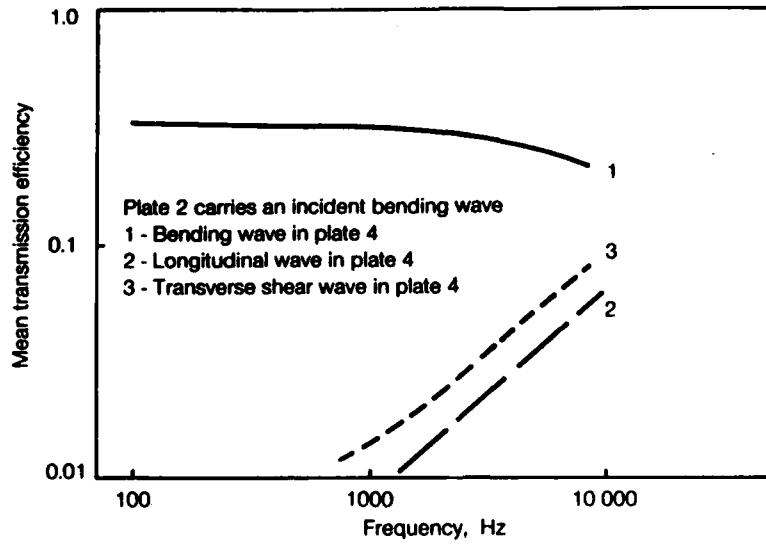

Figure 10: Wave power transmission for junction B.

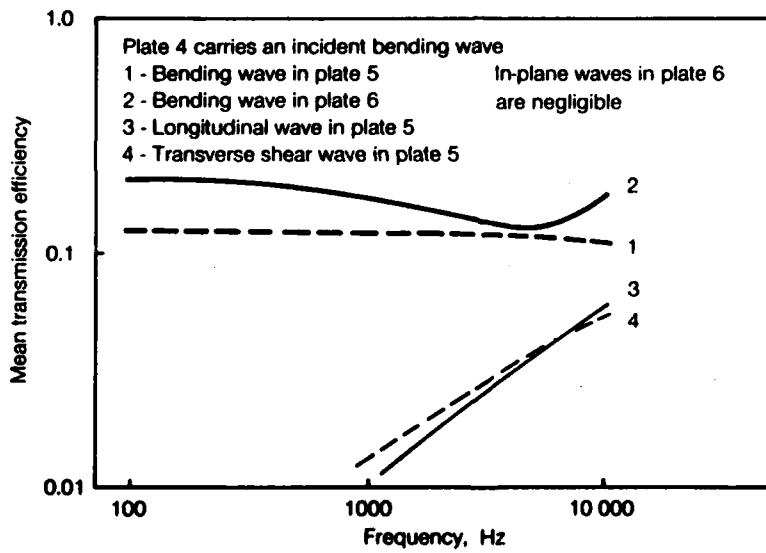

Figure 11: Wave power transmission for junction C.

## 5.2 Plate-Beam Junctions

The mathematical models for a thick beam (Section 2.2.2) and a thin beam (Section 2.3) coupled to thin plates were applied to the plate-beam junction shown in Figure 12. Since the beam thickness chosen in this example is the same as the plate, the beam would vibrate due to the incident wave and it is reasonable to argue that the thin beam model would give a more accurate prediction of the transmission efficiency. Figure 13 shows the bending wave transmission efficiency of the junction calculated by both models. The thick beam model predicts a low-pass characteristic of the plate-beam junction and underestimates the transmission efficiency at frequencies above 500 Hz. The effect of resonant bending frequency of the thin beam on wave transmission can be observed.

As a second example on plate-beam junctions, the beam thickness in Figure 10 is increased to 20 mm. Figure 14 shows the calculated transmission efficiency. Below 1 kHz, the agreement between the thick beam model and the thin beam model is reasonable. At higher frequencies, the thin beam model predicts a higher transmission efficiency, possibly due to the effect of plate resonance. It should be noted that the mathematical models used in this report are based on a thin plate theory and the assumption that the boundary conditions can be applied on the beam/plate centreline. These assumptions may not be justified at high frequencies where the cross sectional dimensions of the junction is not negligible compared with the bending wavelength. Cremer *et al.* (1988, p 115) suggested that the thin plate theory may be used if the bending wavelength is longer than six times the plate thickness. For the present example, this converts to a frequency of approximately 26 kHz. The effect of plate offset from the centreline of a thick beam may be considered by modifying the compatibility and equilibrium equations. This approach has been carried out and reported by Langley and Heron (1990). Despite the assumptions used in the models, the present analysis shows that the conventional heavy beam theory may lead to a serious underestimation of the transmission efficiency when applied to thin beam junctions.

## 6. Conclusions

Analytical methods for evaluating the transmission efficiency of structural junctions have been presented. The mean transmission efficiency may be used to identify and quantify vibration transmission paths in a junction. A study of the mean transmission efficiency of plate junctions shows that the effect of in-plane motions is significant in structure-borne noise transmission, especially at high frequencies. For structural junctions that consist of a thin beam, the elastic vibrations of beam plays an important part in wave transmission and should be considered in the analysis of structure-borne noise.

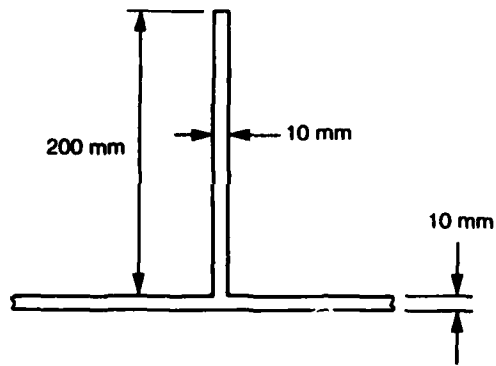

Figure 12: A simple plate – thin beam structure.

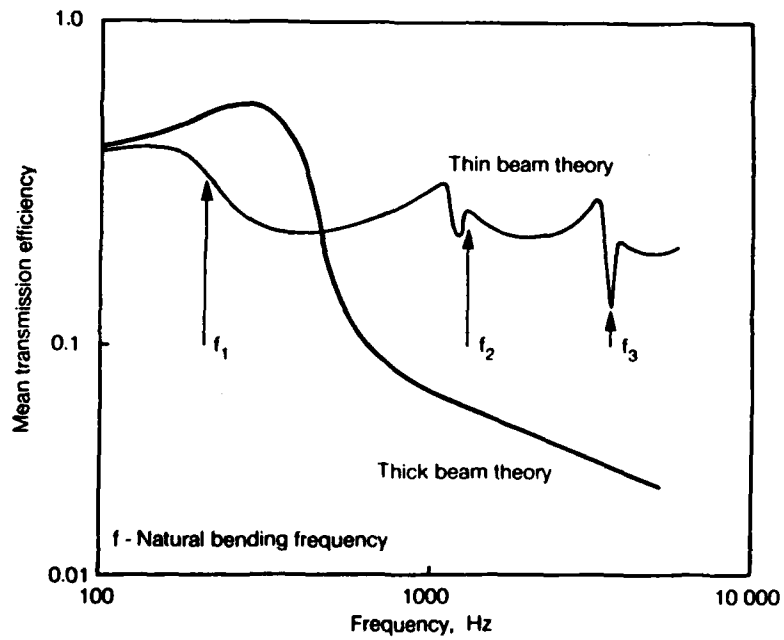

Figure 13: Bending wave transmission for a plate – thin beam junction.



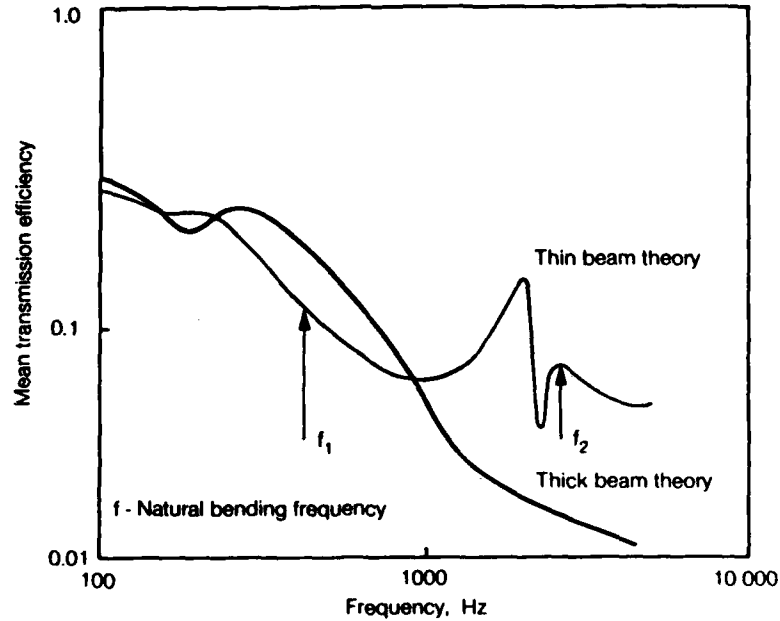

Figure 14: Bending wave transmission for a plate - thick beam junction.

## 7. References

- Craven, P.G. and Gibbs, B.M. (1981). Sound transmission and mode coupling at junctions of thin plates, part 1: representation of the problem. *Journal of Sound and Vibration* 77(3), pp. 417-427.
- Cremer, L. (1948). *The propagation of structure-borne sound*. Department of Scientific and Industrial Research Report No. 1, Series B.
- Cremer, L., Heckl, M. and Ungar, E.E. (1988). *Structure-borne sound*. Berlin: Springer-Verlag.
- Heckl, M. (1961). Wave propagation on beam-plate systems. *The Journal of the Acoustic Society of America* 33(5), pp. 640-651.
- Langley, R.S. and Heron, K.H. (1990). Elastic wave transmission through plate/beam junctions. *Journal of Sound and Vibration* 143(2), pp. 241-253.
- Leissa, A.W. (1969). *Vibration of plates*. NASA Special Report 160.
- Love, A.E.H. (1927). *A treatise on the mathematical theory of elasticity*. Cambridge University Press.

Lyon, R.H. (1975). *Statistical energy analysis of dynamical systems: theory and applications*. MIT press. Cambridge, Massachusetts.

Lyon, R.H. (1986). In-plane contribution to structural noise transmission. *Noise Control Engineering Journal* 26(1), pp. 22-27.

Nilsson, A.C. (1976). Wave propagation in simple hull-frame structures of ships. *Journal of Sound and Vibration* 44(3), pp. 393-405.

Wöhle, W., Beckmann, Th. and Schreckenbach, H. (1981). Coupling loss factors for Statistical Energy Analysis of sound transmission at rectangular structural slab joints, part 1. *Journal of Sound and Vibration* 77(3), pp. 323-334.

## Appendix

### List of Symbols

$A_i$	area of plate $i$
$B$	bending wave
$c_{B_i}c_{L_i}c_{T_i}$	bending, longitudinal and transverse shear wave velocities of plate $i$
$c_{g_i}$	group velocity of plate $i$
$D$	subscript to denote bending ( $B$ ), longitudinal ( $L$ ) and transverse shear wave ( $T$ )
$E_i, E_b, E_f$	elastic moduli of plate $i$ , beam and flange
$\langle E_i \rangle$	time averaged energy of sub-system $i$
$F_{x_i}, F_{y_i}, F_{z_i}$	component of internal plate forces per unit length in the $x_i$ , $y$ and $z_i$ directions of plate $i$
$h_i$	thickness of plate $i$
$I_{x_b}$	second moment of area of beam about axis $x_b$
$I_{z_b}$	second moment of area of beam about an axis parallel to $z_b$ and passes through the beam centroid.
$I_f$	second moment of area of flange about axis $x_2$
$I_b, I_f$	moment of inertia per unit length about longitudinal centroidal axis of beam and flange
$i$	subscript to indicate plate/sub-system number ( $i = 1, 2, 3, \dots, n$ )
$j$	complex operator
$k$	wave number of incident wave
$k_y$	$y$ - component of incident wave number
$k_{B_x}, k_{B_y}, k_{L_x}$	$x$ and $y$ - components of wave numbers for bending, longitudinal and transverse shear waves
$k_{L_y}, k_{T_x}, k_{T_y}$	
$k_{B_i}, k_{L_i}, k_{T_i}$	bending, longitudinal and transverse shear wave numbers of plate $i$

$L$	longitudinal wave
$L_c$	length of coupling line at a junction
$L_w$	width of web
$M_i$	internal bending moment per unit length of plate $i$ , the moment vector is in the $y$ - direction
$M_b, M_f$	moments per unit length about longitudinal centroidal axis of beam and flange
$m_b, m_f$	mass per unit length of beam and flange
$m_i$	mass per unit area of plate $i$
$n$	number of plates in a junction
$P_{INC}$	power of incident wave
$P_{DI}$	transmitted or reflected wave power of plate $i$
$P_{12}$	power lost by sub-system 1 due to coupling to sub-system 2
$q, r$	superscripts to indicate wave type of incident and generated waves respectively
$R_{Bi}, R_{Li}, R_{Ti}$	parameters to represent the cosine function of wave angle for bending, longitudinal and transverse shear waves of plate $i$ as defined by equation (25)
$R_{Bni}$	parameter to represent the cosine function of wave angle for the near field bending wave of plate $i$ as defined by equation (26)
$S$	distance between the beam centroid and the junction
$T$	transverse shear wave
$T_b, T_f$	torsional stiffness of beam and flange
$t$	time
$u_i$	displacement of plate $i$ in the $x_i$ - direction due to transmitted or reflected waves
$u^L, u^T$	displacement of plate 1 in the $x$ - direction due to incident longitudinal and transverse shear waves

$v_i$	displacement of plate $i$ in the $y$ - direction due to transmitted or reflected waves
$v^L, v^T$	displacement of plate 1 in the $y$ - direction due to incident longitudinal and transverse shear waves
$w_i$	displacement of plate $i$ in the $z_i$ - direction due to transmitted or reflected waves
$w^B$	displacement of plate 1 in the $z$ - direction due to incident bending wave
$x_i, y, z_i$	system of co-ordinates of plate $i$
$x_b, y, z_b$	system of co-ordinates of beam
$\alpha$	incident wave angle
$\beta_i$	angle between plate 1 and plate $i$
$\beta_b$	angle between plate 1 and beam
$\phi$	velocity potential
$\gamma_B, \gamma_L, \gamma_T$	wave angles of transmitted/ reflected bending, longitudinal and transverse shear waves
$\eta_{12}$	coupling loss factor between sub-system 1 and 2
$\mu_i$	Poisson's ratio of plate $i$
$\theta_i$	angular displacement of plate $i$ about the $y$ - axis
$\tau(\alpha)$	transmission/reflection efficiency as a function of the incident wave angle, the efficiency is defined as the ration of the transmitted/reflected wave power to the incident wave power
$\tau_m$	mean transmission/reflection efficiency
$\omega$	circular frequency
$\xi_{Bi}, \xi_{BNi}, \xi_{Li}, \xi_{Ti}$	complex wave displacement amplitudes for travelling and decaying bending waves, as well as longitudinal and transverse shear waves of plate $i$ travelling in the positive $x_i$ - direction
$\xi'_{Bi}, \xi'_{BNi}, \xi'_{Li}, \xi'_{Ti}$	same definition as above but with waves travelling in the negative $x_i$ - direction
$\psi$	stream function

SECURITY CLASSIFICATION OF THIS PAGE

UNCLASSIFIED

REPORT NO.  
MRL-TR-93-1

AR NO.  
AR-008-252

REPORT SECURITY CLASSIFICATION  
Unclassified

TITLE

*The evaluation of transmission efficiency and coupling loss factor of structural junctions*

AUTHOR(S)  
Y.K. Tso

CORPORATE AUTHOR  
DSTO Materials Research Laboratory  
PO Box 50  
Ascot Vale Victoria 3032

REPORT DATE  
August, 1993

TASK NO.  
DST 90/134

SPONSOR  
DSTO

FILE NO.  
G6/4/8-4203

REFERENCES  
11

PAGES  
30

CLASSIFICATION/LIMITATION REVIEW DATE

CLASSIFICATION/RELEASE AUTHORITY  
Chief, Ship Structures and Materials Division

SECONDARY DISTRIBUTION

Approved for public release

ANNOUNCEMENT

Announcement of this report is unlimited

KEYWORDS

Structure-borne noise  
Coupling loss factors  
SEA

Elastic vibrations  
Elastic waves

Statistical energy analysis  
Structural junctions

ABSTRACT

The evaluation of transmission efficiency of structural junctions forms an important part in the study of structure-borne noise as it provides the basis for identifying and quantifying the vibration paths in the structure. In this report, analytical methods for evaluating the transmission efficiency of structural junctions including plate-plate and plate-beam junction are described. The calculation of coupling loss factor from the transmission efficiency of a junction for Statistical Energy Analysis (SEA) is also described. Sample calculations of transmission efficiencies on a number of structural junctions are presented. It is found that for typical naval ship constructions that consist of plates coupled to light thin beams, the elastic vibrations of the beams have a significant effect on the transmission efficiency.

SECURITY CLASSIFICATION OF THIS PAGE  
UNCLASSIFIED

The Evaluation of Transmission Efficiency and Coupling Loss  
Factor of Structural Junctions

Y. Tso

DISTRIBUTION LIST

Director, MRL  
Chief, Ship Structures and Materials Division  
Dr J.C. Ritter  
Y. Tso  
MRL Information Services

Chief Defence Scientist (for CDS, FASSP, ASSCM) 1 copy only  
Director, Surveillance Research Laboratory  
Director (for Library), Aeronautical Research Laboratory  
Director, Electronics Research Laboratory  
Head, Information Centre, Defence Intelligence Organisation  
OIC Technical Reports Centre, Defence Central Library  
Officer in Charge, Document Exchange Centre 8 copies  
Army Scientific Adviser, Russell Offices  
Air Force Scientific Adviser, Russell Offices  
Navy Scientific Adviser - data sheet only  
Scientific Adviser, Defence Central  
Director General Force Development (Land)  
Senior Librarian, Main Library DSTOS  
Librarian - MRL Sydney - data sheet only  
Librarian, H Block  
UK/USA/CAN/ABCA Armies Standardisation Rep., c/- DATD (NSO) 3 copies  
Librarian, Australian Defence Force Academy  
Counsellor, Defence Science, Embassy of Australia - data sheet only  
Counsellor, Defence Science, Australian High Commission - data sheet only  
Scientific Adviser to DSTC Malaysia, c/- Defence Adviser - data sheet only  
Scientific Adviser to MRDC Thailand, c/- Defence Attache - data sheet only  
Head of Staff, British Defence Research and Supply Staff (Australia)  
NASA Senior Scientific Representative in Australia  
INSPEC: Acquisitions Section Institution of Electrical Engineers  
Head Librarian, Australian Nuclear Science and Technology Organisation  
Senior Librarian, Hargrave Library, Monash University  
Library - Exchange Desk, National Institute of Standards and Technology, US  
Exchange Section, British Library Document Supply Centre  
Periodicals Recording Section, Science Reference and Information Service, UK  
Library, Chemical Abstracts Reference Service  
Engineering Societies Library, US  
Documents Librarian, The Center for Research Libraries, US

DNA, Department of Defence, Campbell Park Offices CP1-5-05, Canberra ACT