

1991 408

2

AD-A261 727



PL-TR-92-2134

OTH-B RADAR SYSTEM: SYSTEM SUMMARY

Gary S. Sales

University of Massachusetts Lowell  
Center for Atmospheric Research  
450 Aiken Street  
Lowell, Massachusetts 01854

May 1992

Scientific Report #7

DTIC  
ELECTE  
FEB 01 1993  
S E D

Approved for public release; distribution unlimited.



PHILLIPS LABORATORY  
AIR FORCE SYSTEMS COMMAND  
HANSCOM AIR FORCE BASE, MA 01731-5000

93-01763



This technical report has been reviewed and is approved for publication.

  
JURGEN BUCHAU  
Contract Manager

  
JOHN E. RASMUSSEN, Chief  
Ionospheric Application Branch

  
WILLIAM K. VICKERY, Director  
Ionospheric Effects Division

This document has been reviewed by the ESD Public Affairs Office (PA) and is releasable to the National Technical Information Service (NTIS).

Qualified requestors may obtain additional copies from the Defense Technical Information Center. All others should apply to the National Technical Information Service.

If your address has changed, or if you wish to be removed from the mailing list, or if the addressee is no longer employed by your organization, please notify PL/TSI, Hanscom AFB, MA 01731-5000. This will assist us in maintaining a current mailing list.

Do not return copies of this report unless contractual obligations or notices on a specific document requires that it be returned.

# REPORT DOCUMENTATION PAGE

Form Approved  
OMB No. 0704-0188

Public reporting burden for this collection of information is estimated to average 1 hour per response, including the time for reviewing instructions, searching existing data sources, gathering and maintaining the data needed, and completing and reviewing the collection of information. Send comments regarding this burden estimate or any other aspect of this collection of information, including suggestions for reducing this burden, to Washington Headquarters Services, Directorate for Information Operations and Reports, 1215 Jefferson Davis Highway, Suite 1204, Arlington, VA 22202-4302, and to the Office of Management and Budget, Paperwork Reduction Project (0704-0188), Washington, DC 20503.

1. AGENCY USE ONLY (Leave blank)		2. REPORT DATE May 1992	3. REPORT TYPE AND DATES COVERED Scientific Report #7	
4. TITLE AND SUBTITLE OTH-B Radar System: System Summary			5. FUNDING NUMBERS PE 12417F PR ESDO TA01 WUAB Contract F19628-90-K-0029	
6. AUTHOR(S) Gary S. Sales				
7. PERFORMING ORGANIZATION NAME(S) AND ADDRESS(ES) University of Massachusetts Lowell Center for Atmospheric Research 450 Aiken Street Lowell, MA 01854			8. PERFORMING ORGANIZATION REPORT NUMBER	
9. SPONSORING / MONITORING AGENCY NAME(S) AND ADDRESS(ES) Phillips Laboratory Hanscom AFB, MA 01731-5000 Contract Monitor: Jurgen Buchau/OPIS			10. SPONSORING / MONITORING AGENCY REPORT NUMBER PL-TR-92-2134	
11. SUPPLEMENTARY NOTES				
12a. DISTRIBUTION / AVAILABILITY STATEMENT Approved for public release; distribution unlimited.			12b. DISTRIBUTION CODE	
13. ABSTRACT (Maximum 200 words)  This report introduces the basics of radar technology with a strong emphasis on their application to high frequency (HF) Over-the-Horizon radar systems. It is intended for people who have to work with OTH radars, but have little experience with either radar systems or with the interaction of the radar signal with the ionosphere. The report covers the radar equation, receive and transmit antenna design, waveform analysis and signal processing.				
14. SUBJECT TERMS High Frequency; Over-the-Horizon Radar; Radar Equation; Antenna; Signal Processing; Waveform; Detection; Correlation			15. NUMBER OF PAGES 56	
			16. PRICE CODE	
17. SECURITY CLASSIFICATION OF REPORT Unclassified	18. SECURITY CLASSIFICATION OF THIS PAGE Unclassified	19. SECURITY CLASSIFICATION OF ABSTRACT Unclassified	20. LIMITATION OF ABSTRACT SAR	

# TABLE OF CONTENTS

	Page
1.0 INTRODUCTION .....	1
2.0 OTH-B RADAR SYSTEM.....	2
2.1 Introduction.....	2
2.2 Radar System Concept .....	6
2.2.1 Radar Antennas .....	8
2.2.2 Radar Equation.....	18
2.2.3 Noise.....	21
2.2.3.1 Ground Clutter.....	22
2.2.3.2 Spread Doppler Clutter.....	23
2.3 Range-Doppler Signal Processing.....	24
2.3.1 Pulse Waveform.....	24
2.3.2 Frequency Modulated/Continuous Waveform (FM/CW).....	31
2.3.3 FM/CW Signal Processing.....	37
2.3.3.1 Radar Range Processing.....	37
2.3.3.2 Doppler Frequency Processing .....	41
2.3.4 Range-Doppler Windowing.....	45
2.4 Detection/Tracking (D/T) .....	46
2.5 Correlation/Identification (C/I).....	49

DTIC QUALITY INSPECTED 3

Accession For	
NTIS	<input checked="" type="checkbox"/>
CRA&I	<input checked="" type="checkbox"/>
DTIC	<input type="checkbox"/>
TAB	<input type="checkbox"/>
Unannounced	<input type="checkbox"/>
Justification .....	
By .....	
Distribution / .....	
Availability Codes	
Dist	Avail and/or Special
<b>A-1</b>	

## LIST OF FIGURES

Figure No.		Page
1	HF Radiowave Propagation-Ground Coverage .....	3
2	OTH Backscatter Radar Concept .....	7
3	System Block Diagram.....	9
4	Linear Array.....	11
5	Schematic Antenna Pattern.....	13
6	Array Gain vs. Element Spacing.....	16
7	Single Pulse Plus Target Returns .....	25
8	Periodic Pulse Train .....	28
9	Range Folding.....	29
10	Doppler Spectrum.....	32
11	FM/CW Waveform Generation .....	34
12	FM/CW Target Returns .....	36
13	FM/CW Dechirped Signal.....	38
14	FM/CW Range/Doppler Sampling Sequence.....	40
15	(a) RECT Window and (b) SINC Function.....	43
16	ARD Data Sample.....	44
17	ARD Showing A/C Spreading.....	47

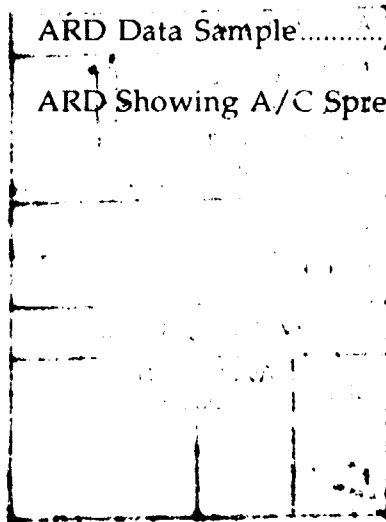

## 1.0 INTRODUCTION

This report summarizing the OTH-B Radar System was prepared, as part of a larger effort by the scientific community to publish a comprehensive "handbook" for use by the U.S. Air Force Over-the-Horizon radar operators at all levels, from technicians on up, that have had only a minimal exposure to the fundamentals of HF radiowave propagation in an ionized medium, the mechanics of the radar and the structure of the ionosphere and its relationship to other geophysical phenomena. The focus of this report is on the application of the fundamentals in these disciplines to the successful operation of the radar, bringing together the several areas of expertise necessary to make a very complex field more understandable.

The need for this material was often illustrated by the "folklore" circulated amongst the operators to explain certain phenomena that did not seem to fit their preconceived understanding of how the radar, the HF radiowave and the ionosphere interacted with each other. At times this resulted in operation of the radar that was less than optimum and it was felt that their overall performance would improve when these operators have access to this type of material.

This work depended on the contribution of several people who took the time and effort to discuss and review this report.

## 2.0 OTH-B RADAR SYSTEM

### 2.1 Introduction

The Over-the-Horizon Backscatter (OTH-B) radar system detects and tracks aircraft approaching the United States at significantly greater distances than those from conventional microwave, line-of-sight radar systems. The OTH-B uses the ionosphere as a mirror to reach out to ground ranges of 3000 km or more to detect approaching aircraft. This reflecting ionized layer is typically at an altitude of 250 to 300 km above the surface of the earth.

Over-the-horizon radiowave propagation uses an ionospheric reflection process illustrated schematically in Figure 1 where rays launched at elevation angles between  $5^\circ$  and  $20^\circ$ , measured relative to the local horizon at the radar, reach the ground at nominal ranges of 1400 to 2,900 km. The zero degree take off angle ray would provide the maximum range (3800 km), depending on the height of the layer, using this very simplified scenario. Since real antennas cannot radiate energy at such low angles, these large ranges cannot be achieved. If it is assumed that a target is observed by the radar at point G in Figure 1, the radar determines the travel time of the radar signal along the nominal ray path R - I - G and back again, providing a measure of the target distance called the slant range. In this simple description, knowing the height of the reflection ( $h=MI$ ), the slant range can be converted into the ground range (R - G) using simple geometry. Together with the radar azimuth, the ground range provides the coordinates of the target, relative to the radar. Details on the conversion of the measured slant range to an estimate of the ground range (called coordinate registration or CR) is given in Scientific Report #6, PL-TR-92-2123.

Continuing with this particular example, receive and transmit antennas are required that are capable of launching rays over the range of elevation angles that provide the desired range coverage for the radar. The OTH-B radar system processes a range interval of 518 nm ( approximately 1,000 km), though the actually useable detection coverage is often less because of the ionospheric conditions. Satisfactory range coverage is accomplished by appropriate choice of transmitter power and antenna design. The receive and signal processing software has been designed to select the start of the processed range interval anywhere from 500 to 1500 nm. At

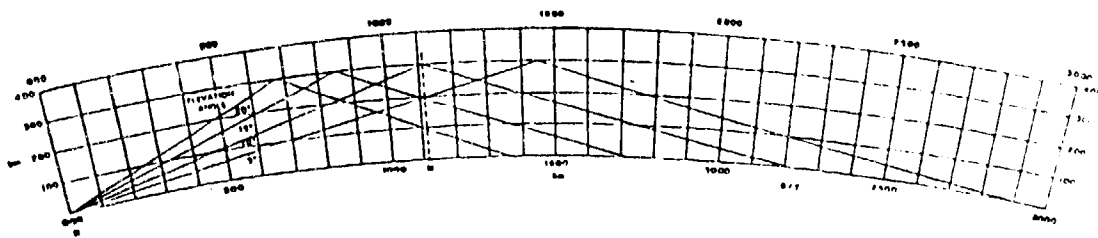

Figure 1. HF Radiowave Propagation-Ground Coverage

COPY AVAILABLE TO DTIC DOES NOT PERMIT FULLY LEGIBLE REPRODUCTION



any particular time, the surveillance range can be moved by changing the operating frequency of the radar (see Scientific Report #6, PL-TR-92-2123) and the radar antenna systems have been designed to provide maximum power in the selected range interval.

So far in this example, the discussion has centered on the radiated energy reaching the distant ground (sea or land). In general, the aircrafts to be detected, fly at altitudes varying from just above the ground to 40,000 feet (approximately 12 km) and sometimes higher. These heights are always a small fraction of the height of the ionosphere and are generally ignored in the geometry of locating a target.

A necessary condition for the successful detection of the aircraft is that the radar is able to see strong land or ocean backscatter returns from approximately the same range as the target. This indicates that the ionosphere is able to support the propagation of radio energy to the desired range.

A typical aircraft radar cross-section varies from  $100 \text{ m}^2$  to  $1,000 \text{ m}^2$  depending on the type of aircraft and on the observing frequency. The illuminated ground underneath the aircraft, contributes backscattered energy at the same range as the target and has a cross-section of some  $10^7$  to  $10^9 \text{ m}^2$  or  $10^4$  to  $10^6$  times larger than an aircraft with a  $1000 \text{ m}^2$  radar cross-section. The concept is that if this large ground area cannot be seen by the radar, then it certainly is not possible for the radar to see a relatively small aircraft.

At this point, a reasonable question is; How can an OTH-B radar detect such a small target as an aircraft against the much larger signal returned by the ground below the target? The simple answer is Doppler frequency processing. Since the aircraft is moving at a typical speed of 1,000 km/hour, it is approaching the radar with a velocity which is some significant fraction of this speed, depending on the angle between the flight path and the radar look-direction. The frequency received from the target is shifted upward when compared to the original transmitted frequency. This shift in frequency after scatter from a moving object is the same as the frequency shift of the whistle on a moving train as observed by a fixed bystander.

The Doppler shift, for the case of an approaching/receding aircraft is:

$$\Delta f = \pm \frac{2v}{c} f \cos\theta \quad (\text{Hz}) \quad (1)$$

where:

$\Delta f$  is the frequency shift, up or down depending on whether the target is approaching or receding,  
 $v$  is the speed of the target,  
 $c$  is the speed of light in a vacuum, and  
 $\theta$  is the angle between the target direction of motion and the radar look direction.

As an example, the Doppler frequency shift is +17.4 Hz, when using the values, for an approaching aircraft, of  $v = 278$  m/s,  $c = 3 \times 10^8$  m/s,  $f = 10$  MHz and  $\theta = 20^\circ$ . The Doppler frequency shift is negative for the receding aircraft.

The ground (land or sea) backscatter return is essentially from a motionless (the effect of the wave motion of the sea will be discussed later) target. This Doppler effect shifts the frequency of the returned signal from the moving target relative to the signal returned from the very much larger ground. This permits the weaker aircraft return to be separated from the very strong ground (sea) returned signal using appropriate frequency processing. The processing that accomplishes this is discussed in greater detail later in the section on signal processing.

At the East Coast Radar System (ECRS), for example, we have a system consisting of a transmitter and receiver, each with an appropriate antenna, for sending and receiving radio energy at a selected frequency within the major part of the HF radio band (5 to 28 MHz). The selection of a specific frequency depends on the ionospheric conditions and the desired range to be illuminated. This is discussed in detail in Scientific Report #6, PL-TR-92-2123.

The radiated energy from the radar follows a path up to the ionosphere, reflects back towards the ground and reaches the aircraft, typically, 2,000 km from the radar. A small fraction of this incident energy is backscattered by the target, a larger amount of energy is backscattered by the rough land or sea below the target and the scattered

energy follows the same path via the ionosphere back to the radar. This returned energy is captured by the receive antenna, then amplified by the receiving system and then computer processed to separate ground and target backscatter and to provide the location and speed of the target.

The OTH-B radar system has a very large receive antenna array resulting in a relatively narrow azimuthal receive beamwidth ( $\approx 2.5^\circ$ ) which is scanned over a  $60^\circ$  segment (see Section 2.2). Actually the U.S. OTH radar system consists of three independent  $60^\circ$  radars, providing a full  $180^\circ$  coverage. It is not necessary for the radar to "stare" at a target since the target normally remains in the coverage area of the radar for a relatively long period of time. For example, with a 1,000 km barrier and a radial speed of 1000 km/hour, the target remains in the coverage area for one hour. This permits the radar to repeatedly scan away in azimuth, look for other targets and then return to each target and continue to acquire additional detection data. The time history of these detections are used to develop a track, that is, a sequence of detections indicating the flight direction and speed of the approaching target.

## 2.2 Radar System Concept

To begin the study, it is useful to examine an overview of the entire OTH-B radar system. Figure 2a shows the ray path geometry of the radar signal through a simple ionospheric layer. Rays with elevation angles of  $3^\circ$  and higher (the maximum elevation angle before penetration is  $11^\circ$ ), provide the ground coverage from 1680 km out to 2800 km. In addition to the ground backscatter from the rough sea or land surface, an aircraft target at a range of 2100 km, in this example, scatters back a small signal that is frequency shifted (Doppler shift from a moving target as discussed above) from the transmitted frequency  $f_0$ . Figure 2b shows, schematically, the received backscattered power from the ground (ground clutter) and from an aircraft target. The ground clutter power decreases, with increasing range because of the spreading of the rays or with uniform steps in elevation angle. This spreading, called geometric spreading or thinning, corresponds to reduced power density on the ground. The interval between 0 km and the skip distance, 1680 km, is known as the skip zone, a region where no radar energy falls at that particular frequency. Finally, Figure 2c shows two sample frequency spectra, one at a range with

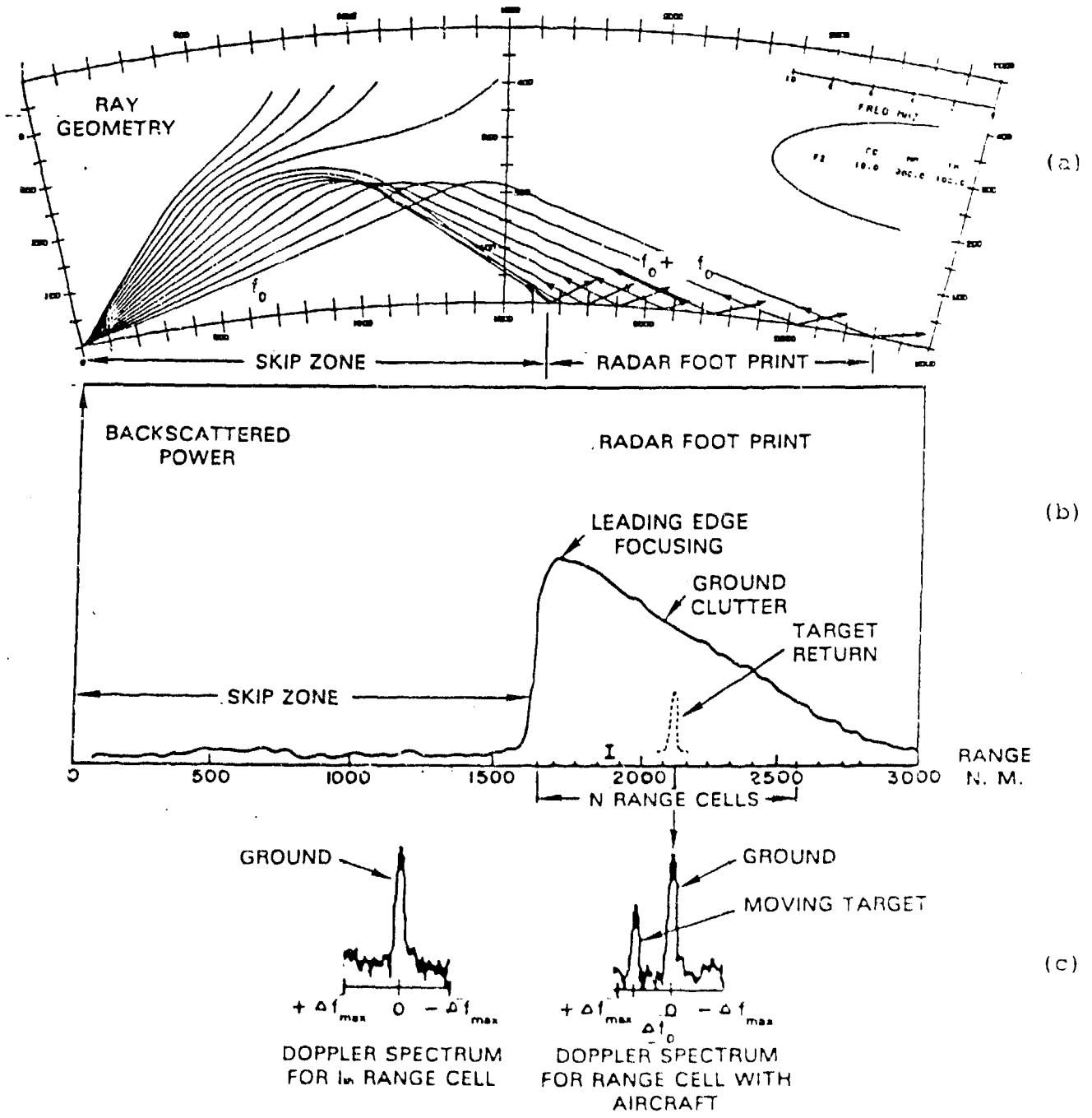

Figure 2. OTH Backscatter Radar Concept

COPY AVAILABLE TO DTIC DOES NOT PERMIT FULLY LEGIBLE REPRODUCTION

no target signal and only a large ground clutter peak at zero Doppler and the second at the target slant range where the target signal is seen Doppler shifted away from the ground clutter peak. This shift makes it possible to detect the target signal in the presence of the much greater ground clutter signal.

Figure 3 is a basic block diagram of the radar system including the propagation medium (ionosphere). The building blocks of the system are addressed in this report except for the ionosphere which was discussed further in the comprehensive handbook created for the radar operators.

### 2.2.1 Radar Antennas

The radar antenna is an electrical device for intercepting (receiving) or radiating (transmitting) electromagnetic energy. It is designed to effectively couple the energy into or out of the free space medium surrounding the antenna in which the radio wave propagates. The receiving antenna converts the electromagnetic field associated with the backscattered signal from the target into a current which is sent to amplifiers and filters, that make up the receiving system. This receiver is designed to increase the signal level and to discriminate against noise to the point where the signal can be processed.

The processing of received signals must be considered against a background of wideband noise which arises either externally to the antenna/receiver system or internally to the system itself, typically thermal noise in the first stages of the antenna amplifier or the receiver.

External noise originates from many sources including thunderstorms, galactic radiation, machinery and other HF users within the operating frequency band of the radar. The recognition of these latter noise sources is the function of the spectrum monitoring system discussed in Section 2.2.3. The OTH-B radar system operates on a non-interfering basis in the HF spectrum, and requires, for successful operation, clear channels which are free of other users. This type of interference in the operating band of the radar affects the radar signal processing and degrades the subsequent detection of targets.

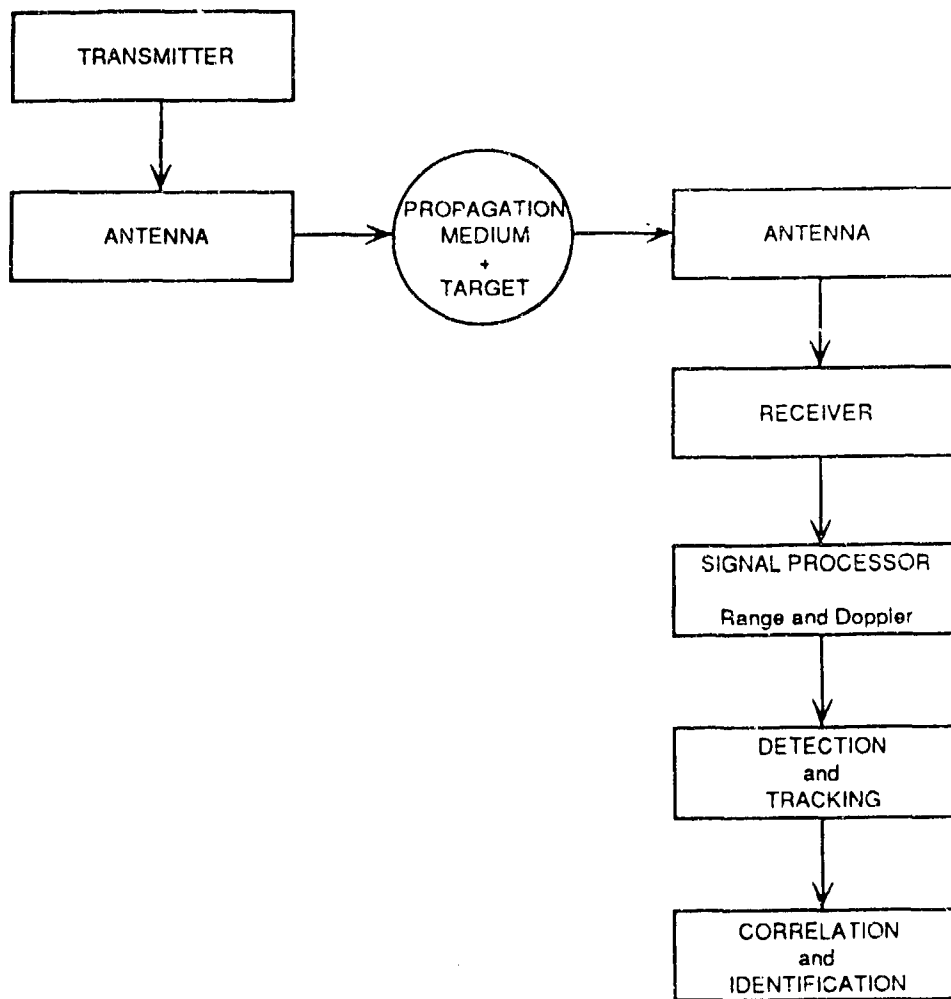

Figure 3. System Block Diagram

External noise, "picked up" by the receive antenna, just as is the target signal and is amplified in the same way as the target signal. For this reason the radar must be designed so that the target signal has sufficient amplitude to be detected after the signal processing stages.

In general, the radar antenna consists of a vertical wire element (monopole) in which a current is induced by the time varying fields in the case of reception or a current is driven by the final amplifier in the case of transmission. Such a simple wire antenna of length less than one half of the wavelength ( $\lambda$ ) of the radiated wave ( $\lambda = c/f$ , where  $c = 3 \times 10^8$  m/s is the speed of light in a vacuum and  $f$  is the radiowave frequency in Hertz), has a more or less omni-directional radiation pattern. This means that a wave arriving from almost any direction can be picked up by such an antenna with equal sensitivity.

A linear antenna array of such monopoles shown in Figure 4 produces a narrow azimuthal receiving (transmitting) pattern. In the following discussion, reference is made to the receiving antenna array, though the analysis applies equally well to a transmitting antenna array. This linear arrangement of antenna elements is used in the OTH-B radar system where such an array achieves a significant increase in directional gain. This means that the sensitivity of the antenna array is no longer azimuthally omni-directional, but that the antenna receives signals arriving from certain specified directions very well while from other directions any arriving signals are strongly attenuated.

This directivity is accomplished by properly phasing the elements of the array and then summing the signals from each element. This requires a phase shift or delay line that is added to each element such that the signals arriving from the desired direction are added together to form the sum which is  $N$  times greater than for a single element ( $N$  is the number of elements). In any other direction the same phasing is such that the summed signals tend to cancel each other and a lower sensitivity is achieved.

This process is known as beamforming and the range of angular directions where relatively low antenna sensitivity is achieved is defined as the sidelobe region. A finite array size (aperture) equal to  $[N-1] \times$  element spacing, results in a finite main

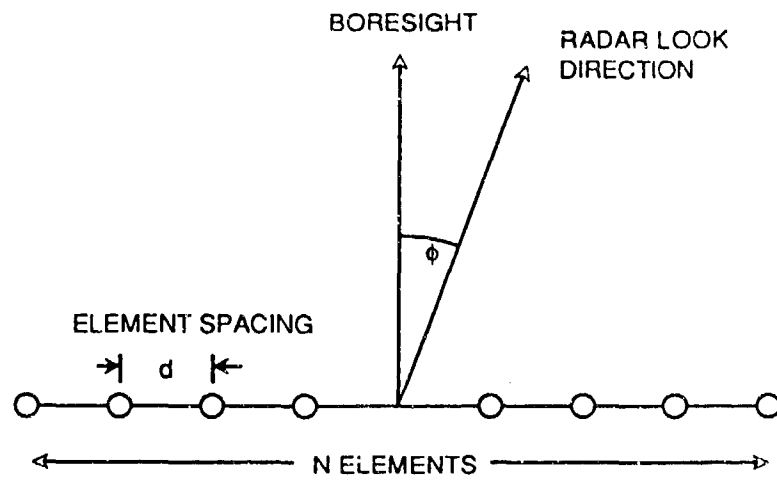

Figure 4. Linear Array



lobe beam width. This means that the angular sector for high sensitivity is of finite angular width, e.g., 2.5° for the receive beam of the OTH-B radar system and 7.5° for the transmit array. The larger beamwidth for the transmit array means that the transmit array has a smaller aperture.

Figure 5 is a schematic of the antenna pattern for a linear array. The antenna pattern is a graph of the relative power gain as a function of azimuthal angle, either in a rectangular or, as in this case, in a polar coordinate system. The angle  $\phi_0$ , the direction that the array is steered, is indicated by the direction of the main lobe. The symmetry of the array elements results in a second lobe in the back direction, which is attenuated by the presence of the high conducting backscreen, spaced approximately a quarter of a wavelength behind the elements of the linear array. The remainder of the angular space outside the main lobes is filled with low sensitivity sidelobes as the several elements go in and out of phase with respect to each other.

A measure of the directivity gain of an antenna array is the half power azimuthal beamwidth (HPBW). The higher the directivity gain, the narrower the azimuthal beamwidth. Here, the HPBW is defined as the angular width of the mainlobe beam, measured at a point where the gain is one half of the maximum gain. The HPBW, expressed in terms of the number of elements  $N$  and the element spacing  $d$ , is:

$$\text{HPBW} \approx 0.886 \frac{\lambda}{Nd} \sec\phi_0 \quad (2)$$

where  $\phi_0$  is the angle the antenna is steered off the boresight direction.

Beam steering is achieved, for the OTH radar, by adding a linearly increasing phase delay to the digitized output of each receiving element of the array as a function of the distance each element is from the end of the array. Since the signals out of the elemental receivers are stored in the computer, different steer directions can be accomplished at the same time. In fact, three receive beams spaced 5° apart are generated for each steered position of the 7.5° transmit beam. This speeds the scanning time of the radar by a factor of three but at the expense of increased processing capability, i.e., to be able to process the signals from the three adjacent

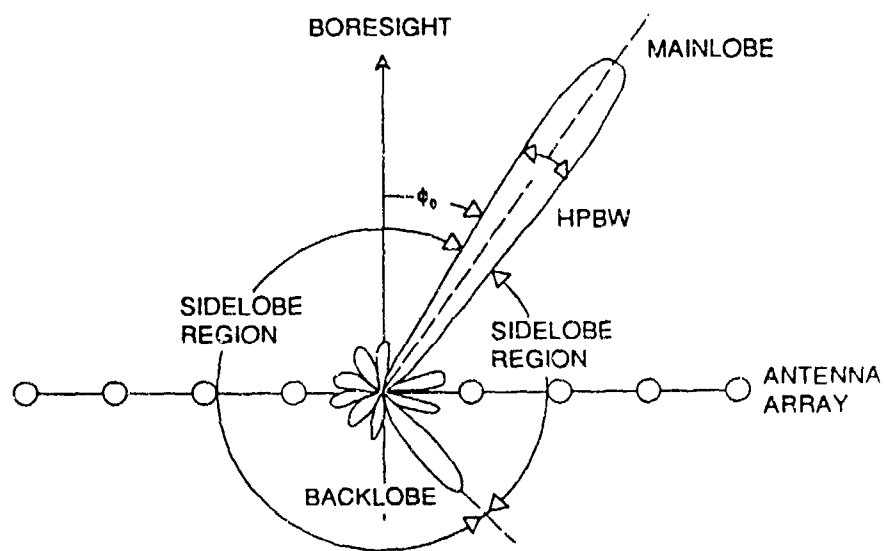

Figure 5. Schematic Antenna Pattern

beams simultaneously. Boresight, for the "broad side" arrays used in the OTH-B radar systems, is the direction perpendicular to the axis of the linear array. The above equation shows that as the array aperture (total length of the array)  $Nd$ , increases, the half power beamwidth decreases.

When the element spacing  $d > \lambda$  the phasing of the elements can result in two or more different directions where all the signals on all the elements add up in-phase giving a strong response. These other lobes, in the other directions, for  $d > \lambda$ , are called grating lobes. This is, in general, an undesirable characteristic since targets received in the direction of a grating lobe will be mistakenly assumed to be coming from the "main" lobe direction. This can be avoided, for an array with a fixed spacing, by insuring that  $d < \lambda$  for all operating frequencies. If the radar operates over a frequency range of 5 to 28 MHz, then  $\lambda$  varies from 60 m to 9.3 m. Besides keeping  $d < \lambda$  for all frequencies and avoiding grating lobes, it is desirable to maintain a nearly constant beamwidth as a function of frequency. To satisfy these requirements, the OTH-B radar system operates with three different receive apertures (and six different transmit apertures) by selecting subsets of 83 equally spaced monopole elements from the full antenna array which consists of 247 elements.

The first subset, for the low frequency band, is achieved by selecting every third antenna in the full array giving the largest element spacing and the largest aperture. As the frequency is changed within this band, the 83 selected elements are kept fixed. At higher frequencies (midband), when  $\lambda < d$ , a second set of 83 elements are chosen with a smaller spacing  $d$  ( every second element is chosen out of the center of the array). This arrangement suffices until at even higher frequencies, when the wavelength again becomes approximately equal to the midband element spacing. Then a third element spacing is achieved by selecting every adjacent element, again in the center of the array, leaving unused, the 83 elements on either side of the centered array. The following table shows the three frequency bands for the receive array, the element spacing and the associated aperture.

### Receive Array Switching Frequencies

Frequency Band (MHz)	Element Spacing (m)	Aperture (m)
5.00 - 9.63	18.3	1519
9.63 - 15.00	12.2	1013
15.00 - 28.00	6.1	506

For each of these arrays, the directional gain (maximum) of the linear array is defined as:

$$D = \frac{4\pi}{\Omega_A} \quad (3)$$

where:

$$\Omega_A = \iint |f(\theta, \phi)|^2 \sin\theta \, d\theta \, d\phi \quad (4)$$

and  $f(\theta, \phi)$  is the two dimensional angular array antenna pattern.

For a uniformly excited array, that is one where the power to each element is the same, and assuming that the elements are omni-directional, this integration is rather straightforward and results in a rather simple result for the directional gain of a linear broadside array as a function of the number of elements  $N$  and the element spacing  $d$ . For the special case where  $d = \lambda/2$  we find for the maximum directional gain:

$$D = N.$$

When  $N = 83$ ,  $D = 19.1$  dBi, where the "i" refers to a comparison with the gain of a single isotropic antenna ( $D=1$  or 0 dB). Figure 6 shows the calculated gain as a function of the spacing  $d/\lambda$ . For a spacing of  $d/\lambda = 0.9$ , the maximum gain is approximately 22 dB. For  $d/\lambda > 1$ , the maximum gain drops, coincident with the formation of a grating lobe appearing at an azimuth of  $90^\circ$  from boresight.

The half power beamwidth for ECRS OTH-B radar receive array, based on the aperture dimensions, varies between  $0.32^\circ$  and  $0.70^\circ$  as a function of frequency. These narrow beamwidths are not achieved in practice because the receive array is usually not uniformly "excited." For the purpose of sidelobe control, that is to reduce the average sidelobe level over the sidelobe region, an important consideration for a radar operating near the auroral zone, an amplitude taper or windowing function is applied to the linear array of elements.

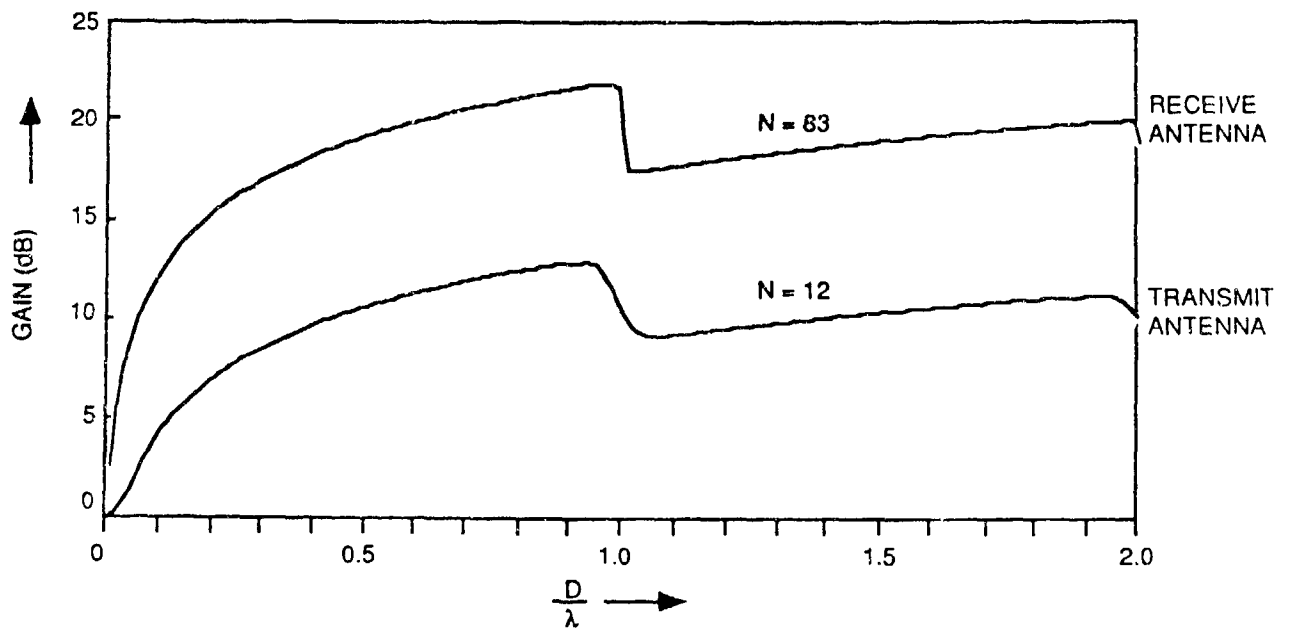

Figure 6. Array Gain vs. Element Spacing

Instead of uniformly exciting the 83 elements of the array, a symmetrically tapered weighting function, one which attenuates the outer elements and leaves the central elements of the array relatively unaffected, is applied to the receive array. With the proper choice of weights, the individual sidelobes as well as the average sidelobe level can be reduced below a specified level, relative to the peak gain. The sidelobes can be set to a level necessary to reduce the intensity of the auroral clutter entering through the sidelobes and thereby reduce the received auroral clutter level against which the detection of the aircraft target signal must be made. This improvement does not apply when the main lobe is pointed directly at the aurora.

This sidelobe suppression comes at the expense of an increase in the azimuthal beamwidth of the main lobe and this is accepted as a part of the cost of reduced auroral clutter. The resultant beamwidth is set at the 2.5 degrees as discussed earlier. The problems associated with auroral and ionospheric clutter are discussed in Scientific Report #6, PL-TR-92-2123.

The transmit array consists of six separate 12-element linear broadside arrays each with a different element spacing (aperture width) to cover the frequency range from 5 MHz to 28 MHz. The following table shows the six transmit array bands, the element spacing and the aperture.

Transmit Array Switching Frequencies

Frequency Band (MHz)	Element Spacing (m)	Aperture (m)
5.00 - 6.74	27.6	304
6.74 - 9.09	20.4	224
9.09 - 12.25	15.2	167
12.25 - 16.51	11.2	123
16.51 - 22.26	8.4	92
22.26 - 28.00	6.2	68

By switching the twelve transmitters to the different arrays as the operating frequency of the radar is changed, a nearly constant transmit beamwidth of 7.5° is achieved. The transmit beam is also steered by introducing a linear phase shift across the array.

## 2.2.2 Radar Equation

In order to understand the operation of any radar system, including the OTH-B system, it is essential to have a good appreciation of the fundamental "radar equation" that relates received power, backscattered from a target, to the parameters of the radar system and the propagation medium between the radar and the target. Following the introduction to the concept of antenna gain, it is now possible to discuss the use of the radar equation to estimate the signal-to-noise ratio (SNR) for any target.

In its most simple form, the radar equation relates the received backscattered power from a target of a given area (backscatter cross-section area) to the parameters of the radar system, the range to the target and losses in the radar system and those incurred in propagating through the ionosphere. The derivation of the radar equation is presented in many references including M. Skolnik's book Modern Radar Systems. One common form of the radar equation is:

$$P_R = \frac{P_T G_T G_R \lambda^2 \sigma_T}{(4\pi)^3 R^4 L_S L_I^2} \quad (5)$$

where:

$P_R$  is the received power in Watts,

$P_T$  is the transmitter power in Watts,

$G_T$  and  $G_R$  are the transmitter and receiver antenna gains respectively, including an estimate of the efficiency of these antennas (the efficiency differentiates the power gain  $G$  from the more simply calculated directional gain  $D$ ),

$\lambda$  is the wavelength of the radiated signal in meters,

$c = 3 \times 10^8$  (ms<sup>-1</sup>),

$\sigma_T$  is the radar backscatter cross-sectional area of the target in square meters (at this point we will only consider the aircraft as the target),

$R$  is the range to the target in meters,

$L_S$  is the system loss, and

$L_I$  is the one way ionospheric loss (absorption).

This basic equation is usually presented in terms of the logarithm (base 10) of the various terms and the results are expressed in decibels, i.e.

$$P_R \text{ (dBW)} = 10 \log P_R$$

where dBW is decibels relative to (above or below) 1 Watt.

Taking the logarithm of both sides of the radar equation produces a new form of the equation that is simpler to use. This is:

$$P_R \text{ (dBW)} = P_T \text{ (dBW)} + G_T \text{ (dB)} + G_R \text{ (dB)} + 2l \text{ (dBm)} + \sigma_T \text{ (dBsm)} \\ - 33 \text{ dB} - 4R \text{ (dBm)} - L_S \text{ (dB)} - 2L_1 \text{ (dB)} \quad (6)$$

where dBm is decibels relative to one meter and dBsm is decibels relative to one square meter, and  $10 \log (4\pi)^3 = 33 \text{ dB}$ .

This form of the equation is convenient to use because only additions and subtractions are necessary. Using this decibel form of the equation is simple, and the results obtained without the aid of a calculator have a 10 percent accuracy.

A simple table below aids in the conversion of any power ratio into decibels with the above accuracy. First, it is necessary to discuss simple powers of 10. For example:

$10^{-6}$	=	-60 dB	
$10^{-5}$	=	-50 dB	
$10^{-4}$	=	-40 dB	
$10^{-3}$	=	-30 dB	
$10^{-2}$	=	-20 dB	
$10^{-1}$	=	-10 dB	
$10^0$	=	+0 dB	
$10^1$	=	+10 dB	
$10^2$	=	+20 dB	
$10^3$	=	+30 dB	
$10^4$	=	+40 dB	
$10^5$	=	+50 dB	
$10^6$	=	+60 dB	etc.



This table can be committed to memory in a matter of seconds. The next table describes the conversion of the numbers between 1 and 10. This second table also applies to the numbers between 10 and 100, and between 100 and 1000, etc. since they are the same after factoring out the appropriate power of 10 using the above table.

Of the numbers between 1 and 10, only three need to be committed to memory:

$$2 \Rightarrow 3 \text{ dB}$$

$$3 \Rightarrow 5 \text{ dB}$$

$$5 \Rightarrow 8 \text{ dB}$$

From these three numbers, the remaining digits can be easily derived.

For example:

$$4 = 2 \times 2 = 6 \text{ dB}$$

$$6 = 2 \times 3 = 8 \text{ dB}$$

$$8 = 2 \times 2 \times 2 = 9 \text{ dB}$$

remembering that the logarithm of a product  $\log(a \times b)$  is equal to the sum of the logarithms, i.e.  $\log(a) + \log(b)$ . The numbers 7 and 9 have been ignored, since are within 1 dB of the values for 6 and 8, respectively.

As an example, consider the ratio 6,722/1. To convert this to decibels, we simply round the number to 6000 which then becomes  $6 \times 1000$ . Converting this to decibels gives  $8 + 30 = 38 \text{ dB}$ . The exact answer is 38.3 dB. For general purposes and for quick analysis, this simple conversion procedure, carried out typically to the nearest decibel, is perfectly satisfactory.

Returning to the radar equation, the terms  $P_T G_T$  are referred to as the effective radiated power, that is, the transmitter power required to produce the same energy on a target with an omni-directional transmit antenna.

To better understand the use of the radar equation, consider a simple problem in modeling an OTH-B radar system. Using typical values:

$$\begin{aligned}
P_T &= 10^6 \text{ W} = 60 \text{ dBW} \\
G_T &= 12 \text{ dB} \\
G_R &= 20 \text{ dB} \\
\lambda &= 20 \text{ m} = 13 \text{ dBm} \\
\sigma_T &= 1000 \text{ m}^2 = 30 \text{ dBsm} \\
R &= 2000 \text{ km} = 63 \text{ dBm} \quad (2000 \times 10^3 \text{ m}) \\
L_S &= 10 \text{ dB} \\
L_I &= 10 \text{ dB.}
\end{aligned}$$

Then  $P_R = 60 + 12 + 20 + 2(13) + 30 - 33 - 4(63) - 10 - 2(10) = -167 \text{ dBW}$ .

The only factors affected by the state of the ionosphere are the radar wavelength,  $\lambda$ , which is related to the radar operating frequency and changes with variations in the ionosphere and the ionospheric losses  $L_I$  which also varies with frequency, time of day, propagation mode (see Scientific Report #6, PL-TR-92-2123) and with other ionospheric factors.

### 2.2.3 Noise

The radar equation has been used to compute the received signal power for the modeled OTH-B radar or for the backscatter sounder if the proper parameters are selected, but the critical factor in determining the detectability of a target is the signal power to noise power ratio, usually shortened to signal to noise ratio (SNR). This ratio is defined as  $(P_R/N)$  in dB where  $N$  is the received noise power (dBW) in the effective bandwidth of the radar processed signal. The expected noise levels can be estimated using established world maps of HF radio noise (e.g. CCIR, Bulletin #322). These noise maps were developed using data sets from which narrow band radio frequency interference from radio transmitters has been excluded. They, therefore, represent only the worldwide levels of the galactic, atmospheric and wideband man-made (industrial and agricultural) noise. Other limitations apply to the noise power levels estimates obtained from the CCIR #322 tables. The most important of these is the omnidirectional antenna systems used to gather the large statistical data sets of atmospheric, galactic and wideband man-made noise. The applicability of these data has to be considered when applied to the relatively directional antennas used for the radar.

These CCIR sources are external to the radar and must be added to the internal front end receiver noise. These maps are given in terms of noise power in a 1 Hz bandwidth ( $N_0$ ), a quantity which varies with frequency, location, season, time of day, as well as other factors. The total predicted noise is then the product of  $N_0$  and the effective bandwidth  $B$ .

The effective processor bandwidth, the Doppler cell frequency width (related to the coherent integration time), is discussed in Section 2.4. For now, with short coherent integration times of the order of 1 second, the effective bandwidth will be of the order of 1 Hz. Then the predicted noise power  $N = N_0$ . Typical values for  $N_0$  at a quiet site such as in Maine, at a frequency of 15 MHz in the autumn daytime, is -184 dBW giving a  $SNR = P_R(\text{dBW}) - N(\text{dBW}) = -167 - (-184) = +17$  dB., sufficient for a reliable detection of a target with a cross section of  $1000 \text{ m}^2$  (see Section 2.4). At different locations, for different frequencies, times of day and seasons, the same radar achieves different SNR's. A target with a smaller radar cross-section, such as a cruise missile, has a proportionally lower SNR.

Multiplicative noise represents an additional component of noise which is part of the radar's own signal, transformed to have a noise like character, which originates through a variety of mechanisms. Multiplicative noise represents a portion of the transmitted radar signal that is backscattered into the radar receiving system and is Doppler spread and, as such, it is proportional to the transmitter power, i.e., it increases when the transmitter power is increased. Another term used to describe multiplicative noise is clutter, or an unwanted radar signal returning back to the radar by some scattering mechanism producing a noise-like signal.

#### 2.2.3.1 Ground Clutter

The most apparent multiplicative clutter is ground clutter which is radar signal backscattered from the rough ground or sea below the target in the illuminated area. Ground clutter, although a very strong component of the backscattered energy, presents no serious problem to the operation of the radar because the ground (land or sea) scattered signal is only slightly Doppler shifted or spread as a result of signal processing, ionospheric motions and motions of the illuminated ground (wave motion of the sea), and appears as a large, relatively spectrally narrow (1 to 2 Hz) amplitude peak near 0 Hz in the processed Doppler spectrum. In general, the

ground clutter is not shifted with respect to zero Doppler frequency and, therefore, except for the slight signal spreading discussed above, represents the same frequency as that of the transmitted signal.

Although the ground clutter peak is generally not widely spread, it does obscure the central region of the Doppler spectrum and can prevent the detection of slow moving targets (small Doppler shifts) or high speed targets which, when the sampling rate is too low, causes these targets to appear as a low velocity target and fall into the region of the Doppler spectrum occupied by the ground clutter returns. More on this subject of target velocity aliasing is found in Section 2.4 on signal processing.

#### 2.2.3.2 Spread Doppler Clutter

Another form of multiplicative noise that has a much more serious impact on the radar's performance is auroral/ionospheric clutter caused by intense irregularities (electron density fluctuations which deviate significantly from the ambient background electron density) in the ionosphere, particularly for radars operating in or near the auroral regions. The quasi-random character of the auroral irregularities, in space and time, results in a noise-like Doppler spectrum which adds to the ambient atmospheric noise. When the auroral backscattered power exceeds the atmospheric noise level, the detection performance of the radar is reduced; under these circumstances, radar performance is characterized as "clutter limited". It is against this combined noise background that the targets must be detected. Increasing the transmitter power and/or transmitting antenna gain (the product of the two is the effective radiated power) to improve detection process will be of no use since both the target signal and the noise level will, from the point where the radar performance is clutter limited, increase together and the target signal-to-noise ratio will remain unchanged. The structure of this ionospheric clutter and how it affects the performance of the radar is discussed in Scientific Report #6, PL-TR-92-2123.

The total noise power is the sum of the atmospheric noise and the multiplicative (ionospheric clutter) noise power. The optimum design of a radar system, from the perspective of effectively managing the noise, is for the ionospheric scattered power to be just at the same level as the atmospheric noise. Any increase in the radiated

power will increase the target signal and the noise in the same proportion and any less radiated power than that producing clutter limited performance will give a smaller ratio of target signal to atmospheric noise power. These are important constraints on the radar parameters for systems operating near regions of intense ionospheric irregularities such as the auroral and equatorial regions.

## 2.3 Range-Doppler Signal Processing

### 2.3.1 Pulse Waveform

To determine the range to a target the radar transmitted signal must have some modulation superimposed on the RF carrier. The classical approach to this problem is to use a pulsed transmission, i.e., the transmitter power is turned on and off. The on-period, known as the pulse duration is usually relatively short compared to the off-period, during which time the receiver "listens" for the scattered echo from the target.

While the AN/FPS-118 radars use a modulation known as Frequency Modulation/Continuous Wave or FM/CW, discussed below in detail, the basic understanding of radar concepts is better understood by first considering a pulse modulation scheme. Figure 7 shows schematically a single pulse transmission and the returned target echoes from two different targets, where the indicated time delays correspond to twice the slant range to the targets (the transmitted signal travels to the target and back to the radar over the same path). These time delay measurements, can be made with great accuracy and converted to the slant range to the target by dividing the time delay by two and multiplying by the speed of light,  $c$ , in a vacuum. This is a slant (or virtual) range since the pulse travels up to the ionosphere and down to the target, and while in the ionosphere, does not actually travel at the speed of light in the ionosphere: in fact the pulse travels at a velocity,  $v_g < c$ , ( $v_g$  = group velocity). The determination of the target coordinates (coordinate registration/CR) requires the conversion of the slant range into ground range.

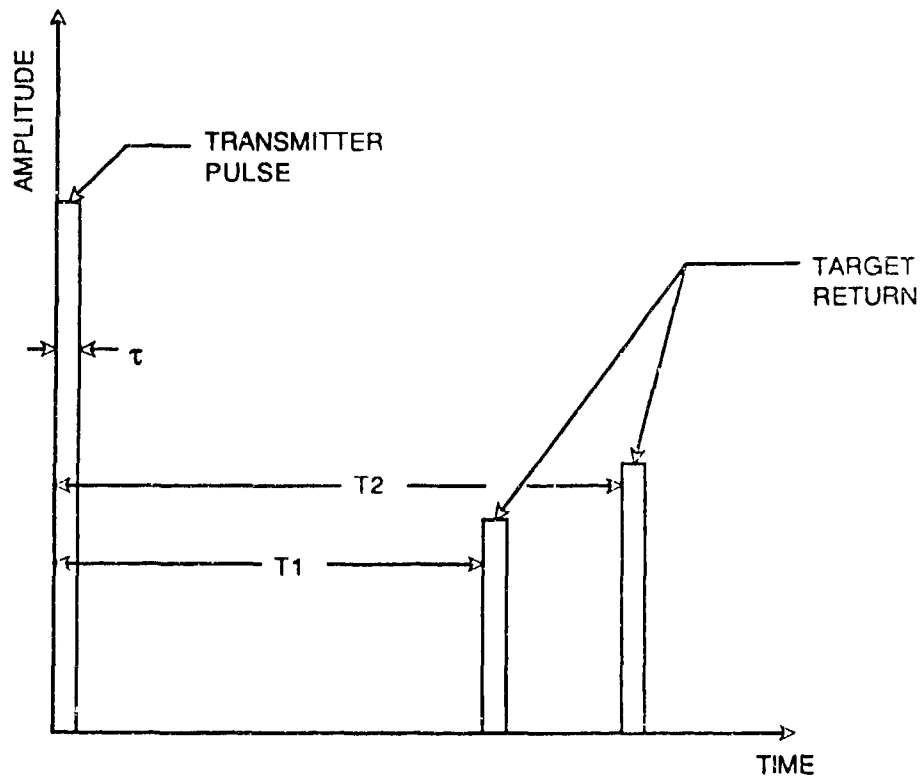

Figure 7. Single Pulse Plus Target Returns

The pulse duration (also referred to as the pulse width) determines the radar's ability to resolve multiple targets that are close to each other in range. When there are two targets present in a particular radar beam, two echoes will be received, each at a time delay corresponding to the range of the respective target. One can see that a problem arises when the two targets come within a certain distance of each other. At some point, usually set at 1/2 the pulse width the two targets can no longer be resolved as two targets, and they are identified as a single target.

It must be remembered that at most ranges, whether there is an aircraft present or not, there is usually a ground clutter return of considerably greater amplitude than any aircraft signal. The detection of the weaker aircraft backscatter return, in the presence of the stronger ground clutter, requires Doppler processing.

Although the OTH-B radar uses the FM/CW waveform, after signal processing, the characteristics of this radar is very similar to a pulsed radar and much of the terminology, such as pulse width, etc., is used and is quite appropriate. For the OTH-B radar, the pulse width varies from 50 to 200  $\mu$ s, with a typical value of 100  $\mu$ s which corresponds to a range resolution of 15 km (pulse duration  $\times$   $c/2$ ). This may seem rather large, but satisfies the mission of the OTH-B system which is primarily early warning and can, after detection of an approaching aircraft, turn over to airborne interceptor radars the job of precise location and resolution. The problem of resolving closely spaced aircraft is discussed again in the section on Doppler frequency processing later in this report. There is a simple relationship between the pulse duration,  $\tau$ , and the transmission bandwidth:

$$B_{RF} = \tau^{-1}.$$

Here, there is a conflict between the range resolution requirements of the radar (to use a small  $\tau$ ) and the difficulty in finding a clear channel in the radio frequency spectrum for bandwidths much greater than 10 kHz which corresponds to a pulse duration of 100  $\mu$ s.

Before discussing the FM/CW waveform modulation used by OTH-B radar systems, another important factor must be considered. No radar system can operate effectively by transmitting a single pulse. For several reasons these pulses must be periodically repeated. First, as we shall see later, these multiple pulses can be used to

improve the detectability of the target signal, particularly when the single pulse SNR is small. Secondly, the repeated pulse returns from the target, each considered as a time sample of the target signal, can, by producing the spectrum analysis from the sequence of pulse returns, be used to measure the Doppler frequency shift associated with an approaching or receding aircraft. As discussed earlier, the Doppler processing is a critical part of the radar signal processing, since the Doppler frequency shift allows the relatively weak target signal to be separated from the strong ground clutter return.

These benefits, obtained by transmitting a sequence of pulses with periodic repetition, introduce a negative factor in terms of range ambiguity. This is illustrated in Figure 8 where a pulse repetition period  $T$  has been introduced. Under these circumstances, it is not possible to determine if the observed target echo comes from the nearest transmitter pulse and has a time delay  $t$  seconds or from the earlier pulse and the time delay would be  $T + t$ . This time ambiguity of  $T$  seconds converts to a range ambiguity  $cT/2$ . For typical OTH-B systems, the pulse repetition frequency (PRF) =  $T^{-1}$  is usually around 40 Hz. This corresponds to a clear unambiguous range of 3750 km.

This means that any target or other return (e.g., ionospheric clutter) seen by the radar, for example at a range of 2000 km, could actually be located at  $3750 + 2000 = 5750$  km or at any other multiple of the range ambiguity added to the measured range of 2000 km. This is not a serious problem for target signals since they are relatively weak signals, typically only 10 to 15 dB above the noise and the uncertainty about the range can be resolved considering that tripling of the range reduces the received power by  $(3R)^4$  (see Equation 5), that is by a factor of 81 or 19 dB. This means that a target signal at a range beyond the unambiguous range of 3750 km has little chance of being detected and confused with a closer target.

The situation is not the same for stronger clutter sources such as auroral/equatorial irregularities. For these ionospheric clutter returns the ambiguity question must be examined carefully before assigning a range to the sources. This is best explained by a detailed example. Assume that there is a target at a range of 3000 km from the radar and long range clutter, at C (see Figure 9a, starting at 12,000 km. If the radar operates at a low PRF of 10 Hz corresponding to an unambiguous range of 15,000 km (unambiguous range is  $c/2$  times  $WRF^{-1}$ ), echoes from the target returns to the radar



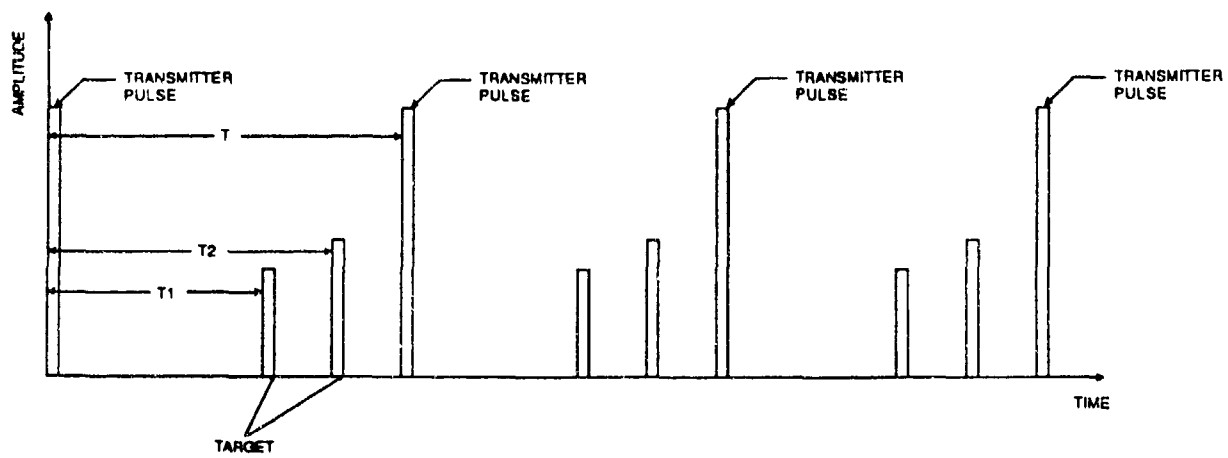

Figure 8. Periodic Pulse Train

# RANGE FOLDING

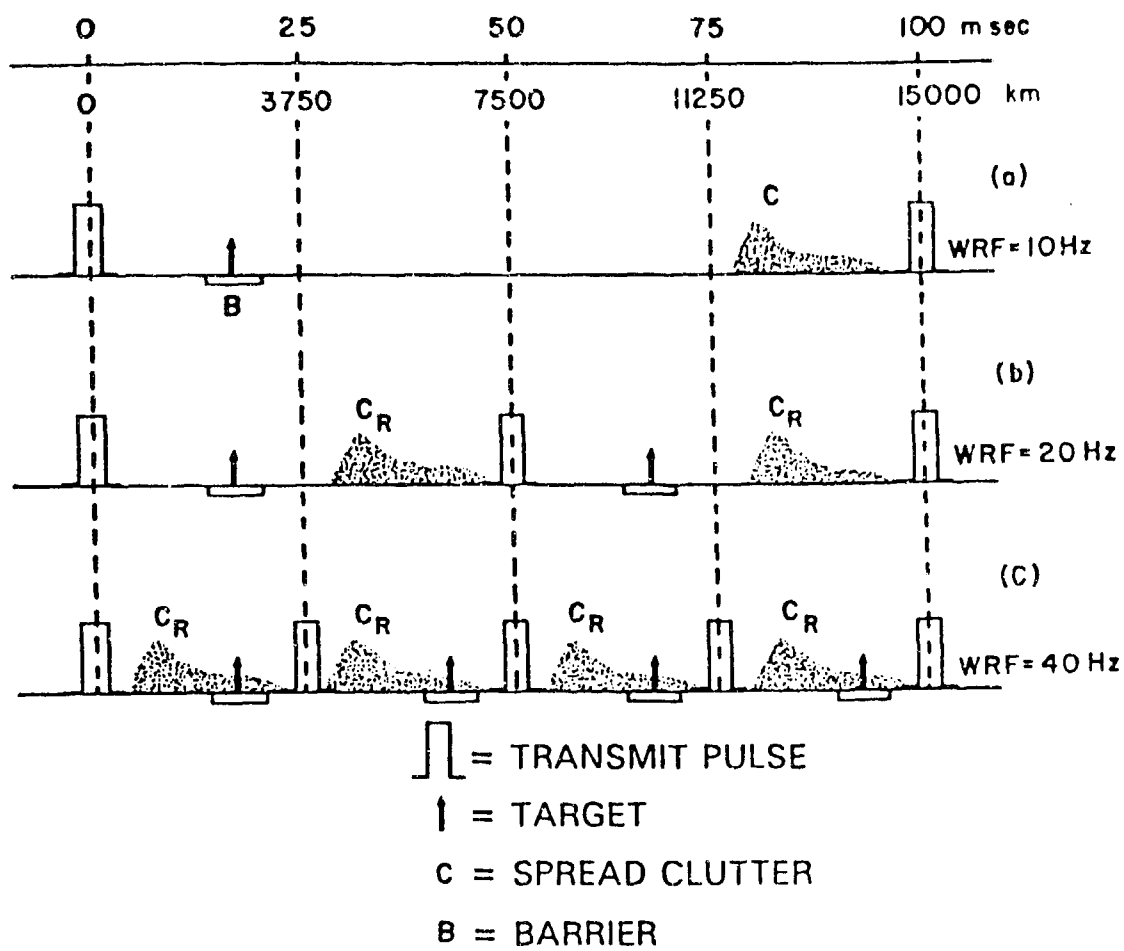

Figure 9. Range Folding

receiver before the next transmitter pulse. In this case, the target and the clutter source are observed unambiguously; i.e., their range is correctly determined. When the radar is operated at a PRF of 20 Hz (unambiguous range is 7500 km, Figure 9 b), the target is observed unambiguously before the next transmitted pulse, while the backscatter returns from the clutter source at 12,000 km is received after the next transmitter pulse. It would be seen with a range ambiguity of 7,500 km at an apparent range of  $12,000 - 7,500 = 4,500$  km.

Finally, operating the radar at a PRF of 40 Hz (Figure 9 c) means that the target and the clutter source, C, are both range folded into the unambiguous range of 3,750 km. In actual operation, the only means for determining whether the particular source (target or clutter) is range folded is to vary the PRF, choosing lower values where the unambiguous range interval is larger and the location of the sources of the echoes is unambiguously determined.

As indicated above, the choice of the PRF affects not only the unambiguous range interval but also the maximum Doppler frequency that can be unambiguously recognized. The same pulse repetition that limits the unambiguous range coverage also affects the unambiguous Doppler coverage by changing the rate at which the target returns are sampled. A basic theorem of spectrum analysis is called the Nyquist criterion. This requires that, in order to recognize a sine wave of a certain frequency, that wave must be sampled at least twice within one cycle of the wave. Therefore for a fixed sampling rate (PRF), the highest frequency that can be unambiguously recognized is  $PRF/2$ , called the Nyquist frequency. Frequencies greater than the Nyquist frequency appear as a lower Doppler frequency, always within the unambiguous Doppler frequency range,  $-PRF/2$  to  $+PRF/2$ . This process is illustrated in Figure 10. For example, as the approach speed of a target increases, the Doppler frequency shift increases until it exceeds the Nyquist frequency. There, it appears to wrap around and reappear as a negative (receding target) frequency. This is an unavoidable condition imposed by nature. This can be a serious problem for radar operation since a fast moving target, approaching the radar, can be interpreted as a receding target or as the approach speed increases, the target return can move into the ground clutter and be masked by it (Figure 10). This speed is known as the "blind" speed; it is a function of the PRF being used at the particular time; the blind speed is the approach speed that makes the Doppler frequency shift equal to the PRF. This masking of the target can be resolved using the same

technique as used for unscrambling the range ambiguity, that is to change the PRF so that the ambiguity limit is different and the target signal no longer falls on the ground clutter return. This is known as Blind Speed Unmasking (BSUM) of the target signal.

Using the Doppler spectrum to determine the target's speed and direction (approach or recede) is in error if the target speed exceeds the speed corresponding to the Nyquist frequency. This is the reason why Doppler frequency shift is not used in the automated determination of the target's speed and direction. These parameters of the target are determined by observing the rate of change of the range of these targets as part of the detection and tracking process. The range and Doppler frequency ambiguities are related to the PRF in a reciprocal fashion. As the PRF is increased, the doppler ambiguity increases while, at the same time, the unambiguous range decreases and visa versa.

One of the main reasons that the pulsed waveform is not used for the OTH-B system is that, with this waveform, the transmitter is off for a large percentage of the total time of observation. The ratio of the on-time, e.g., 100  $\mu$ s to the off-time T, the interpulse period for a PRF = 40 Hz, ( $T = \text{PRF}^{-1} = 25$  ms) is very small, i.e. 0.4%. This ratio, known as the duty factor, is a measure of the total amount of energy available for target detection. The actual detectability of a target can be expressed in terms of this available energy and therefore the pulse waveform is rather inefficient. As a consequence, a more efficient modulation waveform, the FM/CW is generally used in OTH-B radar systems.

### 2.3.2 Frequency Modulated/Continuous Waveform (FM/CW)

The FM/CW waveform is one of the most commonly used modulation waveforms for radar systems today, both for OTH-B and line-of-sight microwave radar. It is a very efficient waveform since it permits a duty factor of 100%. As its name indicates, this waveform uses frequency modulation, that is the carrier frequency (the radar operating frequency) is periodically modulated by linearly shifting the frequency over a range corresponding to the same RF bandwidth (typically 10 kHz) as the pulse waveform.

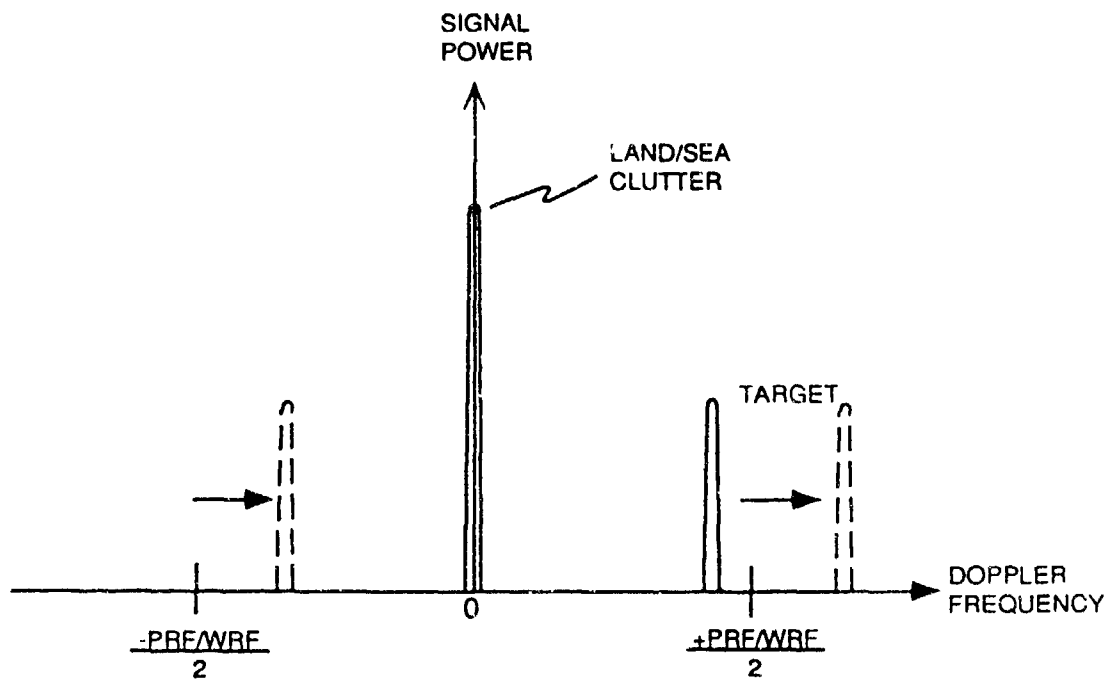
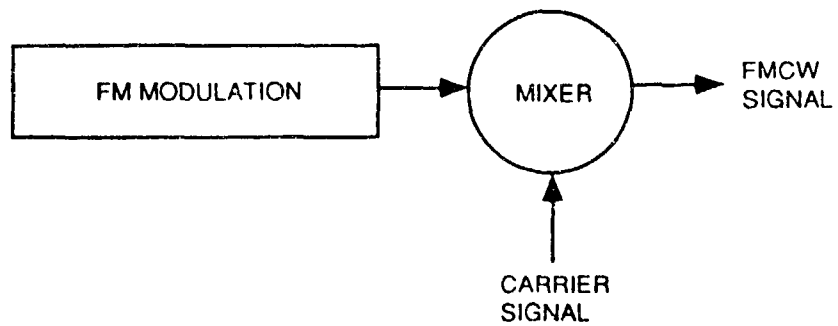

Figure 10. Doppler Spectrum

With the radar's transmitting system radiating continuously, a reasonable question is how does this system achieves a range resolution comparable to that from the pulsed radar. The basic processing that achieves this range resolution is known as pulse compression. Beyond the pulse compression processing, the radar signal structure is essentially the same as in a pulsed radar. Before going into details, it should be recognized that this system, because of the CW nature of the transmission, has a gain factor of 250 over the pulse waveform discussed above ( $\text{duty factor FM/CW} / \text{duty factor pulse} = 1 / .004 = 250$ ). This means that with the same peak transmitter power and antenna gain, this FM/CW waveform produces a radar that is 24 dB more sensitive than the pulse radar.

This high efficiency comes at the cost of requiring separated transmitting and receiving sites. With the transmitter "on" continuously, a collocated receiver would be "blocked" by the very powerful transmissions. To achieve good isolation between the two parts of a high power radar, it is necessary to separate them by 100 to 200 km. The required separation, for good isolation, depends on, besides the radar transmitter power, the terrain profile and ground conductivity between the receiver and transmitter. These two parameters for the terrain between the transmitter and receiver affect the losses suffered by an electromagnetic wave propagating over the ground (ground wave).

A simple representation of the FM/CW modulation scheme is shown in Figure 11a. Here, the carrier CW signal linearly swept in frequency producing a periodic FM modulated carrier (called a "chirp") which is amplified, fed to the antenna system and radiated towards the target. Figure 11b shows the frequency vs. time plot for the modulated wave. As can be seen, the linear sweep is reset periodically after a time duration which corresponds to the time between pulses in the classical system. For the FM/CW waveform, the unambiguous range is related to this waveform repetition frequency (WRF), as was the PRF for the pulse system. This change in terminology only distinguishes between a continuous waveform and a pulse waveform. Finally, Figure 11c shows a schematic representation of the modulated carrier.



(a) Schematic

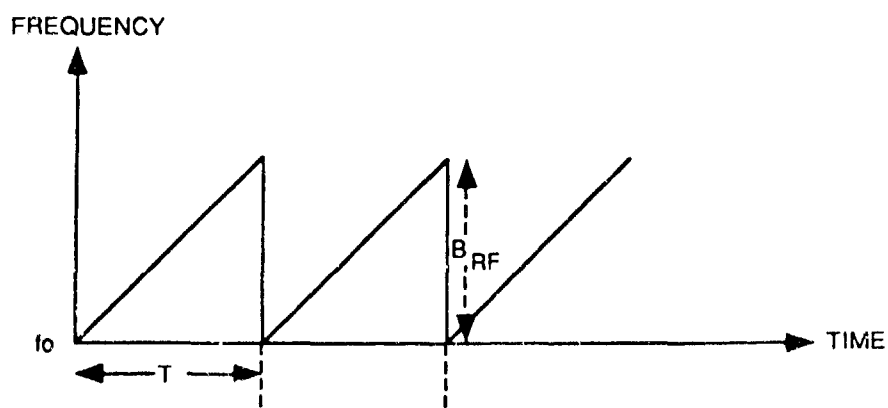

(b) Frequency vs. Time

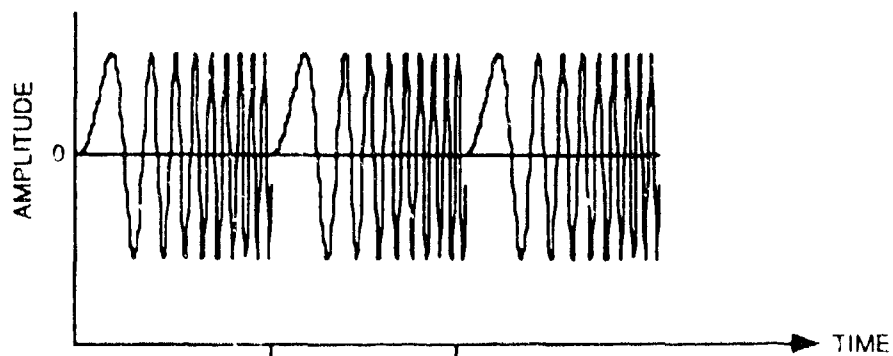

(c) Carrier Modulation

Figure 11. FM/CW Waveform Generation

The bandwidth of the FM/CW waveform is the same as the range of the frequency chirp (that is why these systems are also referred to as chirp radars), normally about 10 kHz, and the same as for the pulse waveform (10 kHz corresponds to 100  $\mu$ s). This FM/CW waveform changes carrier frequency periodically in a linear sweep from " $f_0$ " to " $f_0 + \Delta f$ ", where  $\Delta f$  is the chirp bandwidth.

Referring again to Figure 11a, the receiving system of the FM/CW radar has a demodulating system similar to the modulating system of the transmitting system. The local swept oscillator runs synchronously with the one at the transmitter. This is accomplished by using very precise clocks and frequency standards at both ends of the radar system. The demodulation process generates the frequency difference between the received signal from individual targets and from the distributed (in range) ground clutter and the swept local oscillator. Since the received signal has traveled a distance out to the target and back, when it is "mixed" with the local swept oscillator in the receiver, the two frequencies are out of synchronization and there is now a difference between the two frequencies. The mixing process produces both the sum and difference frequencies and the output of the mixer is low pass filtered to remove the "sum" frequency. The remaining difference frequency is proportional to the time delay of the transmitted radar signal required to travel to the target and back again.

This concept is shown schematically in Figure 12. Here, the target signal, be it either an aircraft at a time delay  $\tau_0$  or the backscatter from the sea at the same time delay, with a frequency difference between the returned signal and the reference (local oscillator) chirp, indicated by the line, of  $Q\tau_0$ , where  $Q$  is the slope of the frequency chirp, typically 400 kHz/sec. Sweeping a chirp range of 10 kHz, at the rate of 400 kHz/s, will take 0.025 sec. For a periodic waveform this leads to a repetition frequency of 40 waveforms/sec (WRF=40 Hz). For a target (aircraft and ground scatter) at a range of 2000 km, with a round trip time delay of 13.33 ms yields a frequency difference of 5.33 kHz. For shorter range targets the frequency difference will be smaller and vice versa for longer range targets. When there are multiple targets in the beam at the same time, each target returns a signal with a frequency which corresponds to the time delay of that target and each target at a different range results in a unique frequency difference. The output of the receiver mixer will be a combined signal with all the frequencies that correspond to the various targets at their respective ranges.



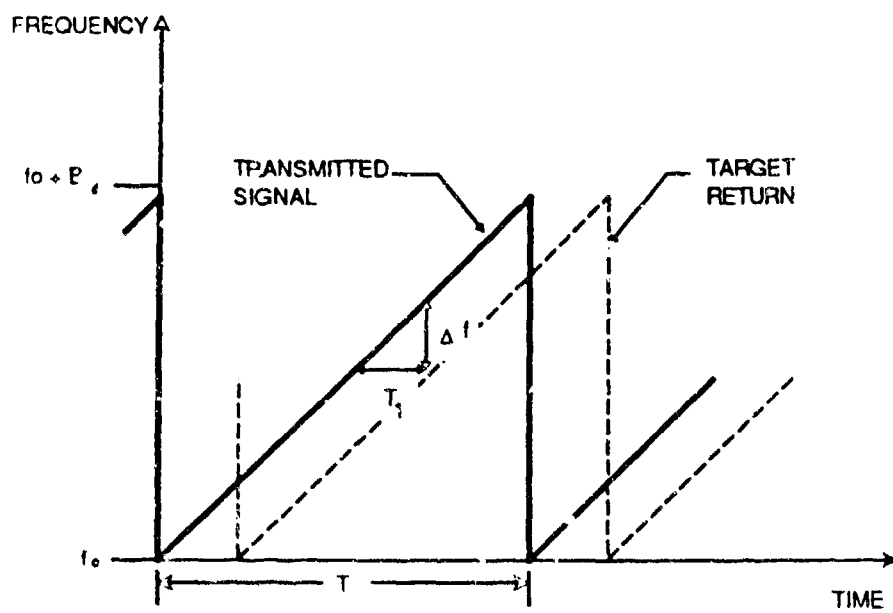

Figure 12. FM/CW Target Returns

### 2.3.3 FM/CW Signal Processing

#### 2.3.3.1 Radar Range Processing

The first requirement of the radar signal processor is to separate the ground clutter frequency components that correspond to the various targets (aircraft and sea scatter) at different ranges. If two or more targets are at the same range, e.g. two aircrafts or an aircraft and the ground beneath the plane, then, as with the pulse radar, they will not be resolved in range. To begin the range processing, the first step is to digitize the output of the mixer (demodulator) after low pass filtering.

With no additional filtering beyond the basic low pass filter, the highest frequency would correspond to the maximum chirped frequency, i.e. 10 kHz. As we discussed earlier, to avoid confusing high speed targets with slow moving ones, a sampling rate is required that meets the criteria established by the Nyquist frequency. This theorem then requires a sampling rate of 20 kHz (that is at least two times the highest frequency in the data being sampled; in this case, 10 kHz) to avoid aliasing or shifting of the received frequency of the target to another part of the processed spectrum. To avoid the large amount of data associated with a 20 kHz sampling rate and to limit the range coverage, a 2.5 kHz low pass filter is inserted before the A/D conversion. This eases the data handling requirements, though it limits the range coverage. With the output of the dechirped (mixed) signal band limited to 2.5 kHz, the sampling rate can then be set at 5 kHz. The digital samples make it possible, through the use of spectrum analysis (Fourier analysis), to measure both the amplitude of the different frequency components in the dechirped received signal; this identifies the radar range to the several targets in the radar beam at that time. Schematically, this is shown in Figure 13.

Fourier analysis is a mathematical process that takes a time varying function (the time domain signal may be in digital form, i.e., a sequence of discrete samples) and forms a set of narrow frequency filters to measure the amplitude of the different frequency components that make up the original time domain signal. An undesirable but unavoidable side effect of the Fourier transform of a data set taken over a finite time duration is the spreading of the signal out of one of the frequency filters into the surrounding filters or spectrum lines.

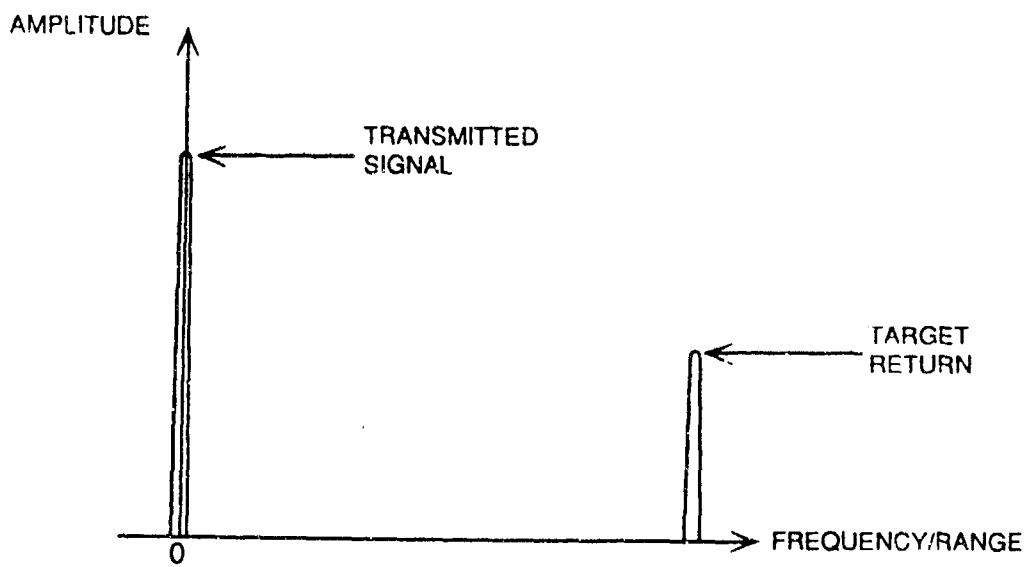

Figure 13. FM/CW Dechirped Signal

To better understand this problem, a short excursion into the theory of Fourier transform or spectrum analysis is necessary. Starting with a pure sine wave, a single frequency of course, will be appear in a single frequency filter only if the sine wave is of infinite length. If the data set acquired to represent the composite dechirped signal, for example, is limited in time duration, as it must be in any real application, the data set can be represented as the result of a hypothetical infinite data set and a time sum domain window function which makes all the samples outside the actual data set zero by multiplying the data values by zero. The most simple example of such a window function (see Figure 14a) is the so called "rectangular" function (RECT), which is zero everywhere except over a finite interval where it has the value of unity. The result of this rectangular function with the infinite time data set gives a finite data set, only where  $RECT = 1$ .

The transform (spectrum analysis) of the finite data set is the transform of the product of the infinite data set with RECT function. A basic theorem of transform analysis is that the transform of the product of two functions is the "convolution" of the transforms of the two functions separately (a type of sliding product of the transform of the two functions), i.e., the transform of the infinite data set convolved with the transform of the RECT function. The transform of the window function is always a spectrum of finite width, spread on either side of a peak. For the RECT function, the spectrum, called the SINC function ( $\sin x/x$ ) is shown in Figure 14 b. Any narrow spectrum lines in the original, infinite data set, when convolved with the SINC function will be spread over the all the frequencies contained in the SINC function (this is a property of the convolution process).

The range processing for the OTH radar is an example of these principles. The number of samples per chirp (in the time domain) is the product of the chirp duration and the sampling rate; at the above sampling rate (5 kHz) and a pulse duration of 0.025 s ( $WRF=40$  Hz), there are 125 samples in one chirp. Actually, the radar parameters are adjusted so that the number of samples is of the form of  $2^n$ , or in this case 128 samples, to make the spectrum analysis more efficient. Each group of 128 samples, corresponding to one chirp, are Fourier transformed into a 128 line spectrum. In this spectrum of the periodic waveform, one for each chirp, the different frequencies appear as a separate lines, each corresponding to a target at different range.

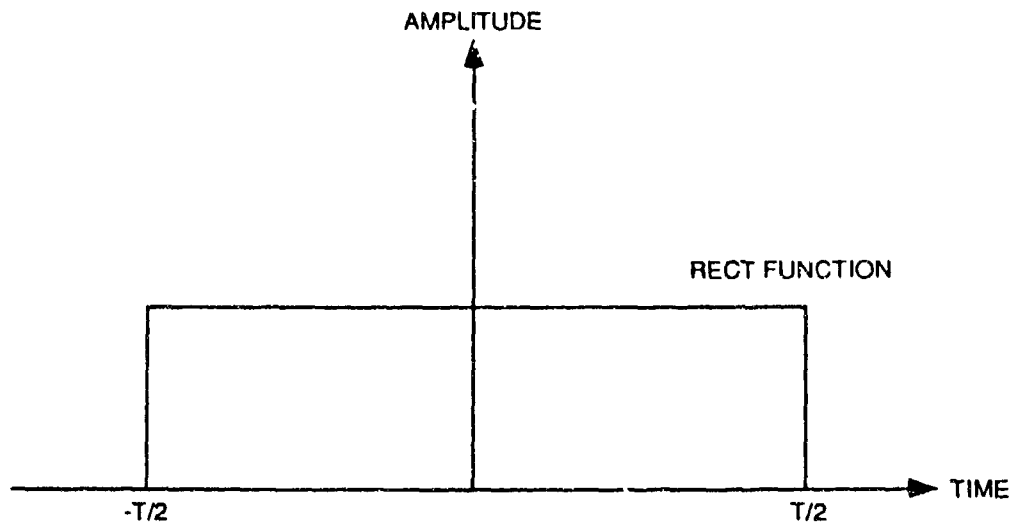

Figure 14a. RECT Window

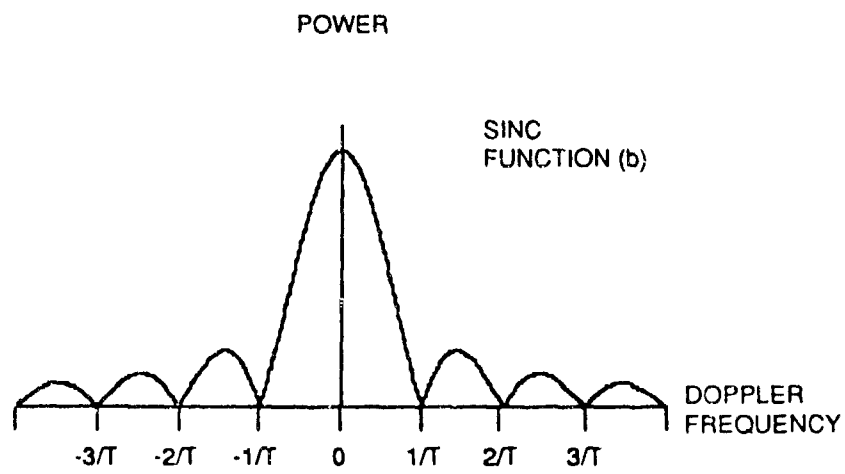

Figure 14b. SINC Function

As an example, consider targets at different ranges from the radar. There is a spectrum line at frequencies that corresponds to the time delay of these targets. The frequency scale ( maximum range is 0 to 2500 Hz) on these spectra is proportional to the time delay or range of the targets. In fact, the frequency start does not have to be at zero, but can be shifted to any frequency (time delay or range start) by offsetting the start of the local swept frequency oscillator used in the receiver mixer.

The power spectrum for a particular target, as displayed in Figure 13 looks exactly like the returned echoes in a pulse radar system. In fact, the spectrum width of each line in the FM/CW range processing output is related to the pulse width of an equivalent pulse radar with the same bandwidth and so the correspondence is complete up to this point. By processing only 2.5 kHz of the possible 10 kHz spectrum there are only 128 samples per chirp waveform; the spectrum output has 128 frequency bins which in turn are interpreted as 128 range bins. The spacing of these range bins is approximately 7.5 km and, as it was with the pulse waveform, it is possible to resolve two targets which are separated by one or more range bins.

This processing, by Fourier transform analysis, is known as pulse compression. The result is a signal gain by the ratio of 25 ms/100  $\mu$ s or 24 dB. Although the original waveform has a 100% duty factor, the resultant pulse display (power spectrum) has all the energy returned from a single target compressed into a single range bin, with the above gain factor.

#### 2.3.3.2 Doppler Frequency Processing

After pulse compression, the Doppler frequency processing for the FM/CW waveform is the same as it would be for a pulse waveform. As discussed earlier, each measured pulse return at a particular range bin is a single sample in a time sequence (from each successively transmitted pulse) that forms the time series for input to the the Doppler Fourier transform. Each waveform repetition provides one sample, at each range bin, for the time duration, corresponding to what is called the coherent integration time (CIT). Coherent integration requires the summing of backscattered signals that preserve the phase of the transmitted signal and thereby

sum more to a greater value than the wideband noise signals which, by the definition of noise, do not maintain a consistent phase and add more slowly. When "n" samples are summed, assuming a stable or slowly changing phase, the SNR increases by a factor of "n".

Using the same example as above, for a 64 line Doppler frequency spectrum, covering the Doppler range of  $\pm WRF/2$  (similar to  $\pm PRF/2$  for the pulsed radar), these 64 samples will take  $64 \times 25 \text{ ms}$  ( $WRF^{-1}$ ), which equals 1.6 sec, the coherent integration time (CIT). For each of the 128 range bins the signal processing has to perform a 64 point Fourier transform. This sequence of range-Doppler samples is shown in Figure 15. The total number of range Doppler bins in this example is  $128 \times 64 = 8192$ ; this number determines the size of the processor for the radar. Given a particular processor, such as for the AN/FPS 118, the configuration can be adjusted so that the number of computed range and Doppler bins can be changed as long as the product of the two numbers remains at 8192.

The signal processing described here is a two step process; range and Doppler spectrum analysis carried out sequentially following more closely the more familiar pulse radar system. To summarize this two step process, first, a 128 point Fast Fourier Transform (FFT) for range is followed, in the second step, by a 64 point FFT for the Doppler frequency process. Although this two step method is often used, it can also be performed as a single step process by taking 8192 time samples at the same rate as in the two step method. The 8192 samples are applied directly to a large FFT processor and the range-Doppler processing is done in a single operation (with somewhat greater efficiency). Mathematically the two methods are completely equivalent and it is not necessary to go into detail of the one step method.

The one step transform processing method does make the one significant difference between the pulse waveform and the FM/CW waveform radars very clear. The output of the one step method is the so called "nested" range-Doppler-amplitude presentation seen on the radar display system in the ECRS operations center, an example of which is shown in Figure 16. This output is the result of the one 8192 point Fourier transform and the display shows a series of ground clutter lines, moving out in range. Between these lines are the nested Doppler spectra covering the range from  $-WRF/2$  to  $+WRF/2$ .

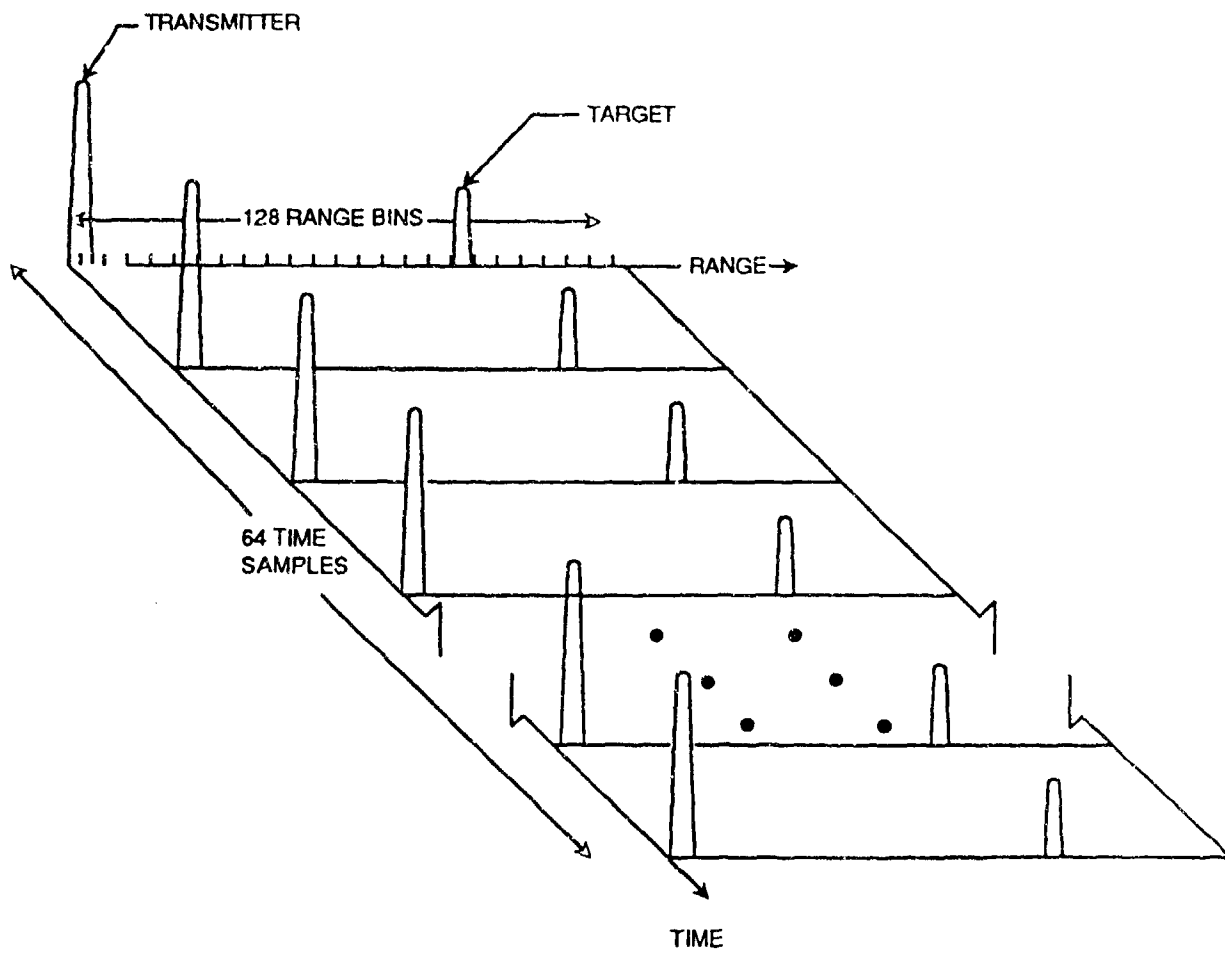

Figure 15. FM/CW Range/Doppler Sampling Sequence



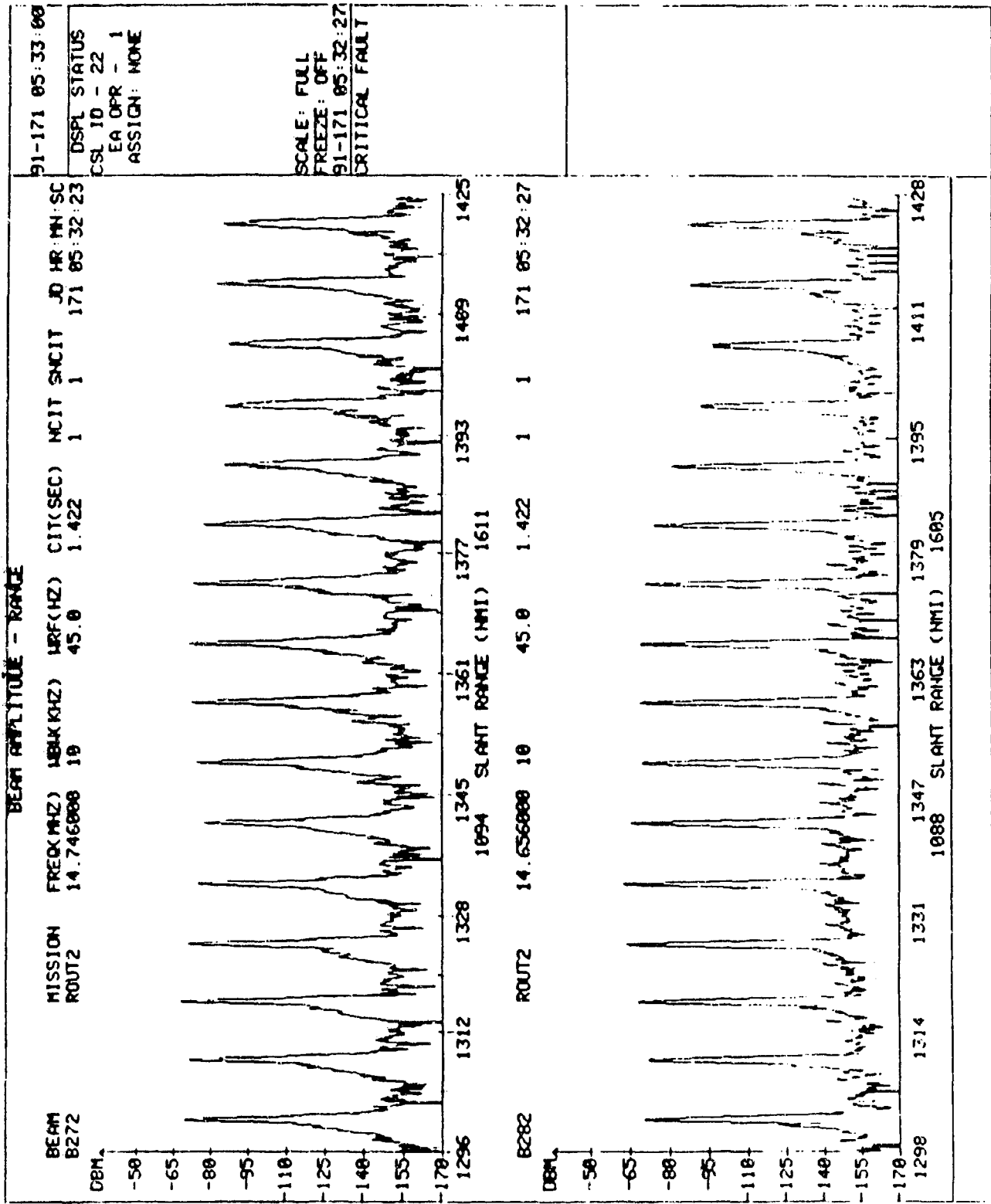

Figure 16. ARD Data Sample

A target signal shown at the indicated range bin is located at a particular Doppler frequency bin at that range. Targets with speeds which exceed the limit set by the unambiguous Doppler frequency range ( $\pm 20$  Hz or  $\pm 300$  m/s or  $\pm 600$  mph at a frequency of 10 MHz) the spectrum line move into the next range bin with a Doppler frequency at the other end of the unambiguous Doppler spectrum. This means, with the assumed radar parameters, that for a target with a speed that just exceeds +600 mph (this is the Doppler folding speed for a 10 MHz operating frequency), the target will appear in the next range bin with an apparent speed of -600 mph.

This coupling between Doppler frequency shift and range does not occur when a pulse waveform is used. With the pulsed waveform, the same Doppler and range ambiguities occur, but there is no range confusion as with the FM/CW waveform. This range-Doppler coupling is an inherent feature of the linear FM/CW chirp waveform and it is something that the radar users have accepted in order to obtain the benefit of the significant compression gain.

#### 2.3.4 Range-Doppler Windowing

The simple rectangular window described above applies equal weights to each sample in the sequence. It should be noted that the range weighting concepts discussed above, apply also to the Doppler frequency sampling. The use of alternative windows has as its goal the reduction of the sidelobe level to avoid spreading strong signal peaks into other parts of the range or Doppler spectrum. As stated earlier, the rectangular or uniform window (also known as the RECT function) produces significant sidelobes over many range or Doppler bins, e.g., at the -40 dB level the sidelobes extend out over  $\pm 30$  range bins from the peak signal. This means that at that level, a strong signal can contaminate a significant fraction of the range or Doppler bins. This is clearly undesirable as it can affect the detection of other weaker target signals and a better windowing function is employed that avoids this spreading.

Alternative windows can be designed which, in the transformed domain, have sidelobes lower than any specified level. The actual selection of the window depends on the sensitivity of the system, that is, on the level of the strong signals compared to the weak signals. Without going into the mathematics of these

windows, there exists the Taylor family of windows, which insures that all the sidelobes lie below any specified level.

This sidelobe level improvement comes at some cost. These improved windows make little contribution through the sidelobes, instead, the strong signal is spread through the broadening of the mainlobe, over a calculable number of range or Doppler bins (from  $\pm 2$  to  $\pm 3$  bins on either side of the peak depending on the selected sidelobe level). Again, this broadening of the main lobe and the reduction of the sidelobe levels through appropriate weighting windows is the equivalent to applying a weighting function to an antenna array as discussed in Section 2.2.1. It is a general rule that the more severe the taper, producing lower sidelobes, the wider will be the mainlobe of the transformed window. This deterministic spreading of the target signal, in range or Doppler, is fully predictable and is compensated for in the target detection processing. An example of the spreading of an aircraft target signal is shown in Figure 17.

#### 2.4 Detection/Tracking (D/T)

Following the range-Doppler signal processing, a number of peaks in the spectrum, some target returns and others from noise spikes, are present. For each receive azimuth beam position (every 2.5 degrees) and range bin, there is a spectrum (64 lines in this example) where some number of the lines have peaks which exceed a preselected threshold. The threshold is applied to eliminate the majority of the weaker peaks that correspond to additive noise (atmospheric and receiver noise), but set at a level that does not affect the target signals. The determination of the threshold level is a complicated process that requires considerable experience.

The threshold level is the level above which the signal is declared a target and below which the signal is identified as noise. With this detection scheme it is possible to make two types of errors. One type of error is to call a signal (a line in the Doppler spectrum) which exceeds the threshold, a target when in fact it is only noise. This is called a false detection or false alarm. The second type of error is when the actual target signal falls below the threshold and then it is called noise. This is a missed detection.

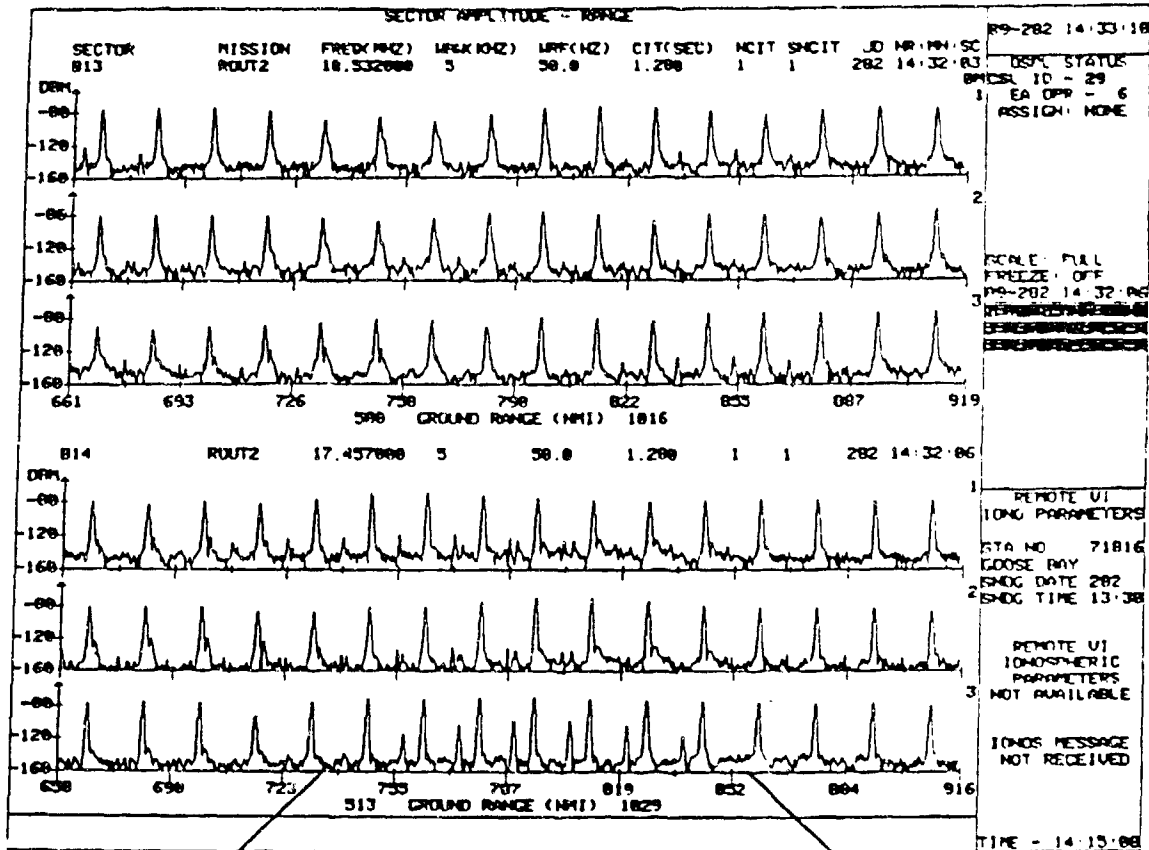

Figure 17. ARD Showing A/C Spreading

Lowering the threshold in an attempt to minimize the second type of error, that is to miss fewer real targets, makes more errors of the first kind in that more of the noise spikes are identified as targets. The trade-off between these two types of errors work in the reverse direction as well, that is when the threshold is increased, the system, by reducing the number of false alarms increases the number of missed detections. How to make the trade-off between these two types of errors depends on the radar application. For OTH-B radar systems, the design tends to lean in the direction of lowering the threshold to avoid missing targets at the expense of having an increased number of false targets carried through the D/T processor. The system can tolerate this increased number of detections as long as the number doesn't get too large and overload the D/T files.

The system is tolerant of these false detections because the radar is a tracking radar. Before a detection is positively identified as an approaching target, several detections must form an acceptable track with parameters that meet the expected profile of an aircraft approaching the radar. In simple terms, this means that after each coherent dwell (1.6 s in this example, but it may be considerably longer, up to 10 s or more depending on how the parameters of the radar are set at the particular time) the new set of detections are compared to the previous sets and only those that form a pattern consistent with aircraft flying at a reasonable speed along a reasonable flight path (not making erratic changes in direction that would be incompatible with a maneuvering aircraft) are declared to be tracks, i.e., targets.

The criteria for maintaining a track, changes as the data base of detections is built up with time. The target remains in the radar barrier for one hour or longer and with the normal scan times (revisiting the target location about once per minute), can be observed many times. By this method, noise detections are ultimately weeded out because they do not form acceptable tracks and so the OTH-B system design of the threshold setting is such as to tolerate more of these false detections with the concomitant benefit of missing fewer real targets. The probability of false alarm is the technical term usually applied to the false detections, but this is misleading terminology for this type of radar. The actual false alarm rate is reserved for those times when a false track is formed, that is, there is no real aircraft on that track. This is a relatively unlikely event when the observation time is sufficiently long.

## 2.5 Correlation/Identification (C/I)

The final part of the signal processing operation is to distinguish between so called "friendly" aircraft in the radar coverage and "intruders" which are defined as those aircrafts which remain unidentified at the time when they approach the inner boundary of the radar coverage. The process of target recognition requires a knowledge of the flight plans or paths of "all" the aircrafts in the radar coverage. This is accomplished by the OTH-B radar systems by obtaining flight information from the Air Traffic Control Centers, particularly the Oceanic Control Centers (OCC) that receive the aircraft position reports from all commercial and some military flights approaching the US.

A distinction is made between a flight plan and a position report. A flight plan is the track that the aircraft is expected to follow, that is, to be at a specified position at a specified time. Position reports represent the information radioed to the OCC as the aircraft proceeds along its flight path towards or away from the United States. Depending on location, these reports are made periodically to the OCC, which forwards this information to the OTH-B radar operations center.

At the radar site, this information is accumulated into a flight path database that is available to the C/I operators for comparison (correlation) with the set of observed radar tracks. These correlations are carried out automatically using a special algorithm for assessing, statistically, the closeness of the radar track and the set of flight paths. One complication arises that must be addressed before the correlation process can be successful. The flight paths are given in ground distance coordinates while the radar tracks are still in slant range which typically exceeds the ground range of the target by some 100 km, depending on the height of the ionosphere and the detailed electron density profiles.

The coordinate conversion process was discussed earlier, where the conversion of the slant range to ground range requires a knowledge of the ionosphere along the ray path from the radar to the detected target. The best source of this information is from the local vertical ionospheric sounding data at the radar site, as well as from the remote vertical soundings from Goose Bay, Labrador, Argentina, Newfoundland, etc., whenever they are available. Ionospheric mapping codes are part of the system software; used to interpolate the measured ionospheric parameters onto a range-

azimuth grid in the coverage region of the radar. Within this software resides a synoptic median model of the ionosphere which is "driven" to closely match the real-time ionospheric measurements by adjusting several of the control parameters that are built into the model. The ionospheric mapping program combines the synoptic model with the real-time soundings to generate a "best" fit map, providing an estimate of the ionospheric parameters at the midpoint of the path from the radar to the detected aircraft. The radar software generates from the on-site and remote vertical soundings, and where or when these are not available, from the resident ionospheric model, tables of reflection heights as a function of range, separately for each 7.5° sector. This is essential since frequencies can be selected independently for each sector (for example, to maintain the barrier at a constant range) even though the ionosphere is changing as the radar swings around in azimuth. These tables are called "coordinate registration" tables or CR tables and provide the means to convert the radar/slant range, using geometric principles (see Figure 1).

Of importance to the generation of realistic CR tables, especially in the absence of ionospheric data, in real-time are the Precision Navigation (PNAV) aircraft. These are aircraft, equipped with inertial navigation systems which reliably report their positions (e.g., national carriers such as PAN AM, TWA, Lufthansa and others). With their known precise positions, the measured slant range to the aircraft can be used to compute an exact reflection height. The CR tables are then automatically corrected to this PNAV height. The correction affects the CR table over a certain range around the aircraft.

The radar software actually has several methods for making this coordinate transformation, depending on the available ionospheric data. When none of the remote vertical sounding data are available, the system falls back to the site sounding, in conjunction with a simple model of the ionosphere over the entire coverage region. Another choice for the operators is to override the model and select a fixed mirror reflector at a constant height, so that the coordinate conversion process becomes a simple exercise in geometry. This subject of coordinate registration remains a subject of research as to the best method for carrying out the conversion. In order to best correlate the flight paths with the radar tracks this conversion should be done as accurately as possible, consistent with the available data, particularly when the density of flights is high.

The correlation process, part automatic and part manual, searches for a match between the known flight paths and the several declared tracks that exist at the same time. With accurate coordinate registration, as each track is correlated with a flight path, it is identified as that flight and removed from the set of tracks which still need identification. This process continues until all possible tracks at a particular time are correlated and identified. If, after the best efforts of the C/I manual and automatic processing, a track cannot be correlated with a known flight path, then it is declared uncorrelated. The unidentified tracks are forwarded to higher authorities for action.