

AD-A257 747



2

# NAVAL POSTGRADUATE SCHOOL

## Monterey, California

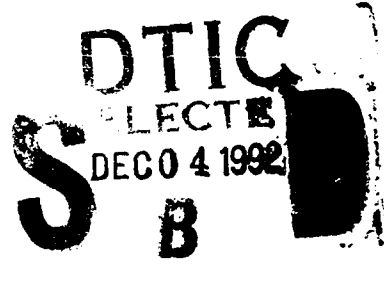

# THESIS

IR IMAGING FOR COMBUSTION CHARACTERISTICS  
AND  
OPTICAL PROPERTIES OF BORON / BORON OXIDE  
by

Yang Jen-Cheng

June, 1992

Thesis Advisor:

David W. Netzer

Approved for public release; distribution is unlimited

92-30832



REPORT DOCUMENTATION PAGE			
1a. REPORT SECURITY CLASSIFICATION Unclassified		1b. RESTRICTIVE MARKINGS	
2a. SECURITY CLASSIFICATION AUTHORITY		3. DISTRIBUTION/AVAILABILITY OF REPORT Approved for public release; distribution is unlimited.	
2b. DECLASSIFICATION/DOWNGRADING SCHEDULE			
4. PERFORMING ORGANIZATION REPORT NUMBER(S)		5. MONITORING ORGANIZATION REPORT NUMBER(S)	
6a. NAME OF PERFORMING ORGANIZATION Naval Postgraduate School	6b. OFFICE SYMBOL (If applicable) AA	7a. NAME OF MONITORING ORGANIZATION Naval Postgraduate School	
6c. ADDRESS (City, State, and ZIP Code) Monterey, CA 93943-5000		7b. ADDRESS (City, State, and ZIP Code) Monterey, CA 93943-5000	
8a. NAME OF FUNDING/SPONSORING ORGANIZATION Naval Air Warfare Center, Weapons Division	8b. OFFICE SYMBOL (If applicable)	9. PROCUREMENT INSTRUMENT IDENTIFICATION NUMBER	
8c. ADDRESS (City, State, and ZIP Code) China Lake, Ca 93555		10. SOURCE OF FUNDING NUMBERS	
		Program Element No.	Project No. S92FZW30007G
		Task No.	Work Unit Accession Number
11. TITLE (Include Security Classification) IR Imaging for Combustion Characteristics and Optical Properties of Boron / Boron Oxide			
12. PERSONAL AUTHOR(S) Yang Jen-Cheng			
13a. TYPE OF REPORT Master's Thesis	13b. TIME COVERED From To	14. DATE OF REPORT (year, month, day) 1992, June 18	15. PAGE COUNT 42
16. SUPPLEMENTARY NOTATION The views expressed in this thesis are those of the author and do not reflect the official policy or position of the Department of Defense or the U.S. Government.			
17. COSATI CODES		18. SUBJECT TERMS (continue on reverse if necessary and identify by block number)	
FIELD	GROUP	SUBGROUP	
		Boron oxide, Infrared, Optical properties	
19. ABSTRACT (continue on reverse if necessary and identify by block number) An experimental investigation was conducted to determine if a new high speed IR microscope could be used to study the ignition and combustion characteristics of boron/boron carbide and to measure the particle emissivity as a function of temperature. Air heater limitations did not permit the investigation of ignition characteristics. Emissivity in the 2 - 5 μm band was measured as a function of temperature using a small boron filament. Data obtained using different IR band-pass filters resulted in significantly different results due to the apparent dependence of the emissivity of boron oxide on both temperature and wavelength. It was also found that care must be used to insure that the entire image is in sharp focus and that a means must be provided for measuring an accurate surface temperature.			
20. DISTRIBUTION/AVAILABILITY OF ABSTRACT <input checked="" type="checkbox"/> UNCLASSIFIED/UNLIMITED <input type="checkbox"/> SAME AS REPORT <input type="checkbox"/> DTIC USERS		21. ABSTRACT SECURITY CLASSIFICATION Unclassified	
22a. NAME OF RESPONSIBLE INDIVIDUAL David W. Netzer		22b. TELEPHONE (Include Area code) (408) 646-2980	22c. OFFICE SYMBOL AA/Nt

Approved for public release; distribution is unlimited.

IR Imaging for Combustion  
Characteristics and Optical Properties  
of Boron / Boron Oxide

by

Yang Jen-Cheng  
Lieutenant Commander, Republic of China Navy  
B.S., Chung Cheng Insitute of Technology, 1979

Submitted in partial fulfillment  
of the requirements for the degree of

MASTER OF SCIENCE IN AERONAUTICAL ENGINEERING

from the

NAVAL POSTGRADUATE SCHOOL  
June, 1992

Author:

  
Yang Jen-Cheng

Approved by:

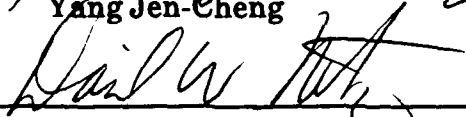
  
David W. Netzer, Thesis Advisor

  
David Laredo, Second Reader

  
Dainel J. Collins, Chairman  
Department of Aeronautics and Astronautics

## ABSTRACT

An experimental investigation was conducted to determine if a new high speed IR microscope could be used to study the ignition and combustion characteristics of boron/boron carbide and to measure the particle emissivity as a function of temperature. Air heater limitations did not permit the investigation of ignition characteristics. Emissivity in the 2 - 5  $\mu\text{m}$  band was measured as a function of temperature using a small boron filament. Data obtained using different IR band-pass filters resulted in significantly different results due to the apparent dependence of the emissivity of boron oxide on both temperature and wavelength. It was also found that care must be used to insure that the entire image is in sharp focus and that a means must be provided for measuring an accurate surface temperature.

<b>Accession For</b>	
NTIS GRA&I	<input checked="" type="checkbox"/>
DTIC TAB	<input type="checkbox"/>
Unannounced	<input type="checkbox"/>
Justification	
By _____	
Distribution/	
Availability Codes	
Dist	Special
A-1	

## TABLE OF CONTENTS

I. INTRODUCTION .....	1
II. EXPERIMENTAL APPARATUS .....	11
A. HEATER .....	12
B. IR IMAGING SYSTEM .....	15
C. HIGH SPEED MOTION-PICTURE CAMERA .....	16
D. EXPERIMENTAL APPARATUS LAYOUT .....	16
III. EXPERIMENTAL PROCEDURES .....	19
A. GENERAL OBSERVATION OF BORON FILAMENT .....	19
B. RESISTANCE HEATING OF BORON FILAMENT .....	19
C. THERMOCOUPLE INSTALLATION .....	20
D. WINDOW EFFECTS .....	20
E. IR IMAGING SYSTEM OPERATING TECHNIQUES .....	22
IV. RESULTS AND DISCUSSION .....	24
A. THE EMISSIVITY .....	24
B. THE EMISSIVITY OF BORON OXIDE .....	24

V. CONCLUSIONS AND RECOMMENDATIONS . . . . .	29
LIST OF REFERENCES . . . . .	30
INITIAL DISTRIBUTION LIST . . . . .	33

## LIST OF TABLES

1. Thermodynamic comparison of fuels..... 2
2. Window material effects on measured boron emittance at 350 °K..... 21

## LIST OF FIGURES

1. Semi-quantitative map of various rate-limiting processes in oxidation of element boron in oxygen.....	4
2. Model for low-temperature stage in the combustion of boron particle.....	6
3. Physicochemical processes in the combustion of boron/poly (BAMO/NMMO) solid fuel in air.....	8
4. Schematic diagram of the vitiated air heater.....	13
5. The initial layout of experimental apparatus.....	17
6. The final layout of experimental apparatus.....	18
7. The averaged emissivity of boron oxide in $2\ \mu\text{m} - 5\ \mu\text{m}$ band in the lateral direction...	26
8. The averaged emissivity of boron oxide in $2\ \mu\text{m} - 5\ \mu\text{m}$ band in longitudinal direction...	27
9. The radiation intensity of boron oxide.....	28



## ACKNOWLEDGEMENT

This thesis was sponsored by the Naval Air Warfare Center, Weapons Division and the Naval Postgraduate School.

First of all, I would like to express my sincere appreciation to my thesis adviser, Professor D. W. Netzer, and co-adviser Dr. D. Laredo a NRC research associate for their guidance, encouragement and patience throughout the course of this study.

I would also like to thank Dr. B. Natan for his initial guidance to this experimental investigation field. The assistance of Mr. P. Hickey and Mr. H. E. Conner of the Naval Postgraduate School is greatly appreciated in performing the boron filament tests.

Finally, I would like to take this opportunity to express my deepest gratitude to my wife Kuei-Yu and my sons Chun-Chieh and Chun-Yaw for their encouragement and self sacrifice in support of my efforts.

## I. INTRODUCTION

In the past several decades, the solid fuel ramjet (SFRJ) has become an attractive candidate for new and improved propulsion technology, because of its high specific impulse compared to rockets and its relative simplicity compared to other air breathing devices. An increasing interest in high-energy-density fuels for use in the SFRJ has resulted in growing emphasis on the use of metallized fuels, such as boron or boron carbide with hydroxy-terminated polybutadiene (HTPB).

Solid particulate boron has received considerable attention in recent years due to its remarkably high gravimetric and volumetric heating values. As indicated by Talley [Ref.1], the heating value of boron is considerably higher than those of carbon, aluminum, and magnesium. Table I shows that boron is an ideal candidate for the development of a high-energy fuel. However, extracting the theoretical energy is not so straightforward. Boron particles are difficult to ignite and to sustain combustion because of a molten oxide layer, which is formed around the particle. This layer serves as a barrier between the oxygen and the boron. In the SFRJ, prior to their ejection into the flowfield, boron particles tend to coalesce and form relatively large agglomerates [Ref. 2], whose burning times may be long compared to the residence time in the combustor [Ref. 3]. Unlike the combustion process of most typical hydrocarbon fuels which are well understood, the present knowledge of the mechanisms of ignition and combustion

of solid particulate boron are incomplete. Under many practical situations the energy release from boron is low compared to its theoretical potential, and poor combustion efficiencies can be expected [Ref. 4].

Table I. Thermodynamic comparison of fuels [Ref. 1]

Fuel	Density	Heat of Combustion	
	gm./cc.	Kcal./gm.	Kcal./cc.
Boron	2.34	13.90	32.40
Boron-carbide	2.52	12.40	31.40
Carbon	2.25	7.83	17.60
Magnesium	1.74	5.91	10.30
Aluminum	2.70	7.42	20.00
Gasoline	0.74	11.50	8.51

Another interesting solid fuel is boron-carbide ( $B_4C$ ). Boron-carbide has almost the same energy potential as boron.  $B_4C$  has 89.3% of the heating value of boron on a weight basis and its volumetric heating value is 96.9% that of boron (see Table I). Moreover,  $B_4C$  has a better shelf-life, is much more stable than pure boron and its cost is considerably lower [Ref. 5]. Again, there is also lack of detailed experimental data, and the ignition and combustion mechanisms for  $B_4C$  are virtually unknown.

Boron and  $B_4C$  particle temperatures during the ignition process have never been measured accurately to provide data for validation of the mathematical models which have been developed. The surrounding gas temperature has been measured at some distance from the particle [Refs. 6,7,8]; however, it has never been measured close to

the particle. In addition, the actual temperature gradient around the particle is unknown.

In the past 30 years or so, numerous investigations of boron (but not for boron carbide) ignition and combustion in the form of rods, single particles and slurry agglomerates of particles have been conducted by using electrical resistance heating, flat flame burners, pulsed lasers, electronic balance/electrical heating furnaces or microwave induced plasma emission spectroscopy (MIPES).

Talley [Ref. 1] measured the consumption rate of 1 mm diameter boron rods by electrically heating them up to temperatures between 1100 and 2300 °K in a pure oxygen environment at various pressures. He presented various rate-limiting processes for the oxidation of elemental boron in oxygen as a function of temperature and pressure (Fig. 1). He divided the temperature range of 0-5000 °K into five regions. In region I, the rate-limiting process was the diffusion of oxygen through a glassy film, which resulted in a slow reaction rate. Region II begins at temperatures above the melting point of  $B_2O_3$  (723 °K). As the temperature was increased to approximately 1100 °K, he concluded that the rate of evaporation of oxide and the rate of removal of oxide by flow of liquid under the influence of gravity dominated the mechanisms of oxide removal. He observed that a transparent viscous liquid coating covered the boron surface completely as a uniform thin film ( $B_2O_3$ ) which was about 10  $\mu\text{m}$  thick at one atmosphere with a temperature of about 1200 °K and 1400 °K in region II and region III respectively. He also concluded that the burning rate of boron rod in region III was controlled by the outward diffusion rate of  $B_2O_3$  (g), which maintained equilibrium with a liquid layer of  $B_2O_3$ . As the temperature goes higher to regions IV and V, the rate is no longer retarded

by the presence of a protective liquid coating, but rather, is limited by the gas-phase diffusion of oxygen through boron oxide vapor. Although many of the details are still poorly understood and somewhat controversial, this general description has been supported by most subsequent theoretical and experimental works.

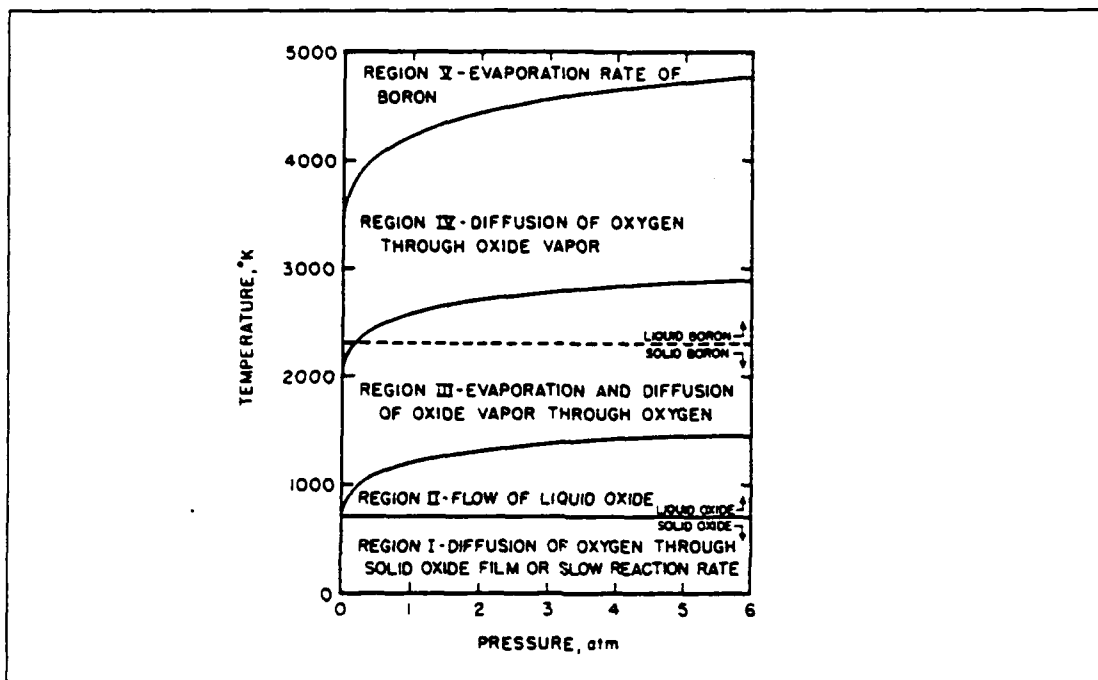

Figure 1. Semi-quantitative map of various rate-limiting processes in oxidation of elemental boron in oxygen (after Talley [Ref. 1])

Maček and Semple [Ref. 6] presented a comprehensive study of the ignition of crystalline boron particles, approximately  $40 \mu\text{m}$  in diameter, in the post-flame zone of a flat-flame burner. They observed two successive stages of combustion. In the first stage (after heat up to about  $1800 - 2000 \text{ }^\circ\text{K}$ ), the particle ignited and burned brightly for a short period of time, and then seemed to extinguish. Then the particle reignited and burned completely in a second stage, which was much brighter and longer than the first stage. These two stages were later defined as "ignition" (or "low-temperature") and

"combustion" (or "high-temperature") stages. In addition, to verify the two-stage combustion mechanism, they observed burning times for each stage from time-exposed photographs. Both burning times were found to be inversely proportional to the mole fraction of oxygen and to decrease substantially with the addition of water vapor. Although the effect of water had not determined so quantitatively, Maček et al point out that the addition of water vapor increased the burning rate and can change the chemistry of pertinent reactions to a major extent. The ignition temperature of boron particles (1850 to 2000 °K) was found to be independent of particle size and of gas temperature, but affected by the composition of ambient gases. They measured the ambient temperature required for ignition, defined as the critical ignition temperature. This temperature was found to be around 1920 - 1930 °K for particles 35 - 45  $\mu\text{m}$  in diameter in a dry atmosphere.

Mohan and Williams [Ref. 7 ] also conducted an investigation of the ignition of the crystalline and amorphous boron particles in the 100  $\mu\text{m}$  range. The particles were supported at the tip of a 10  $\mu\text{m}$  glass fiber by natural adhesive forces, then ignited by a pulsed laser in a chamber filled with known mixtures of oxygen and nitrogen. The ignition and combustion of boron particles were then recorded by a 16-mm Hycam high-speed motion-picture camera at measured framing rates typically of 5000 fps. Experimental observation included long periods of one-sided, low temperature burning for crystalline boron, and almost explosive combustion for amorphous boron. An oxide-coating model [Fig. 2], very similar to that of King [Ref. 9] was developed for describing the low-temperature ignition phenomena. They assumed that the layer of  $\text{B}_2\text{O}_3$

(l) was thin enough to be treated as a planar geometry which is bounded by solid boron at B and by the ambient gas at C.

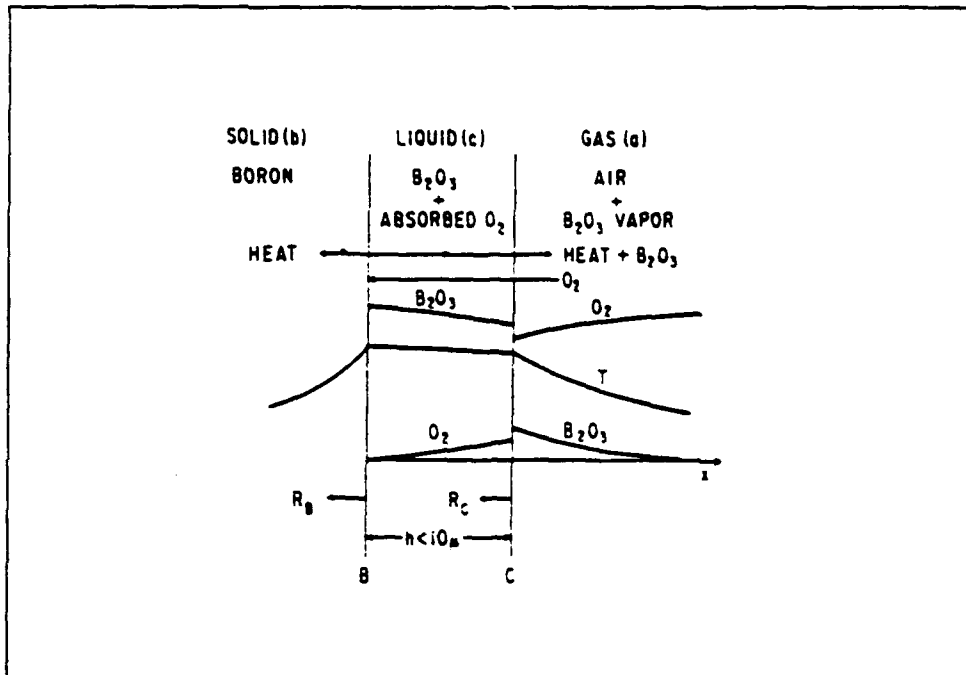

Figure 2. Model for low-temperature stage in the combustion of boron particles (after Mohan et al [Ref. 7])

They also assumed that a diffusion-controlled reaction of  $O_2$  with boron produced  $B_2O_3$  (l) and released heat at interface B; an equilibrium vaporization of  $B_2O_3$  and an equilibrium absorption of  $O_2$  at C. The over-all reaction that occurs was  $2B(s) + (3/2)O_2(g) \rightarrow B_2O_3(g)$ .

Boron particle ignition is clearly complex, intriguing and controversial. The overall processes which occur during boron particle ignition and combustion may be described as follows [Ref. 10]: A cold boron particle having a very thin solid boron oxide coating on the order of  $10 \text{ \AA}$  (assumed by most investigators) is injected into a hot, oxidizing gas. Heat transfer by convective and/or radiative flux(es) from hotter

surroundings causes the particle temperature to rise, with the oxide coating melting at roughly 720 °K (the first-stage ignition). Oxygen and/or boron diffuse across the liquid oxide layer and tend to react more rapidly as the particle temperature increases. As the oxidation of the boron particle continues, it causes the oxide layer to thicken, thereby increasing resistance to diffusion. At the same time, boron oxide is ejected from the particle surface by evaporation and diffuses away from the particle at a rate which depends upon the particle temperature. However, evaporation is an endothermic process, which tends to cool, or at least lower the rate of heating of the particle. Further increases of particle temperature cause rates of evaporation of the relatively volatile oxide also to increase, tending to reduce the thickness of the oxide layer. If the particle temperature becomes high enough (approximately 1900 °K), the rate of oxide vaporization exceeds that of production and ignition eventually occurs (i.e. the oxide layer thickness reaches zero and a temperature runaway will occur). This leads to the second-stage ignition. On the other hand, if the sum of heat transfer from the surroundings and non-negligible particle self-heating terms (King assumed that at sufficiently high particle temperatures of approximately 1500-1800 °K the particle self-heating should be considered, whereas Mohan et al [Ref. 7] and Maček et al [Ref. 6] assumed it negligible during ignition) drops below the vaporization heat demand before the surface is cleaned, the particle will not ignite [Ref. 9].

If ambient temperature or rates of reaction are sufficiently high, the boron particle melts (ca. 2450° K). This temperature level and those near the boiling point of boron (ca. 3930° K) are rarely attained in practical propulsion systems. Fig. 3 shows a





the surface of the boron. This simplified viewpoint of diffusion-limited burning has been recently questioned by Glassman et al., who, based on results of carbon combustion (whose reaction mechanism is believed to be similar to that of boron combustion), discussed the possibility that, for small particles of relevance to propulsion systems, finite rate kinetics at the surface could assert a much stronger influence than previously assumed. The latter mechanism was based on evaluation of boron and oxygen solubilities in liquid boron oxide. Regardless of the mechanistic details, it is general agreed that to achieve rapid combustion of boron, the oxide layer must be removed.

The above discussion has indicated the complexity of the ignition and combustion processes of boron particles and that the processes are qualitatively understood. However, quantitative accuracy for the prediction of ignition and burning rates is lacking and the models developed to date have not been adequately validated. The situation with boron carbide is considerably worse, with no adequate models for ignition or burning rate. This lack of understanding has required empirical development of boron containing fuels for ramjets and ducted rockets. In solid fuel ramjet applications, catalysts and/or small amounts of more easily ignited metals (e.g., magnesium) are often used to enhance ignition and combustion of the boron or boron carbide. The use of these catalysts and/or "enhancers" is undesirable since they reduce the specific impulse. However, the minimum required quantities of these additives have not been determined experimentally or analytically. In addition, it has also not been determined where these additives can be most effectively utilized (as a coating on the boron, imbedded in the fuel matrix, etc.). No ignition or combustion models have been developed which can be used to guide the

use of these additives. Thus, somewhat expensive experimental efforts using subscale fuel grains are currently required.

In addition to the combustion phenomenon of boron and boron carbide, the optical properties of boron oxide are important for the accurate prediction of plume signature [Ref. 21]. Additional data are needed on the effects of temperature and contaminants (from the combustion process) on the emissivity.

The purpose of this investigation was to determine if a new high speed IR imaging microscope could be used to examine the ignition and combustion characteristics of boron/boron carbide in order to provide new data for model validations and an inexpensive means for evaluating the effectiveness of the combustion catalysts/enhancers and for measuring the optical properties. This required developing a source of dry, hot air for heating an individual particle or filament of boron to above the oxide melting (720 °K) and particle ignition (1900 °K) temperatures. In addition a technique had to be found which would permit the accurate measurement of surface temperature in order to determine the surface emittance from the radiance received by the IR camera.

## II. EXPERIMENTAL APPARATUS

The experimental investigation of the ignition and combustion of boron and boron-carbide using an IR microscope imaging system has not been attempted before. There were several equipment limitations that had to be addressed, such as protecting the IR microscope from exposure to temperatures in excess of 125 °C, observing the hot material within the 4 mm focal distance of the microscope, etc.. Therefore, many efforts were devoted to the set-up of a suitable experimental apparatus. Spherical particles of boron or boron carbide were not available. Boron filament could be obtained with small diameters. The initial idea was to heat a boron filament or a boron-carbide agglomerate with an air heater in which the composition (mole fraction of oxygen, catalysts, etc.) of the air could be varied. The filament/particle was to be heated (initially at atmospheric pressure) by forced convection, once the heater, microscope protection and particle/filament support techniques were developed. The IR camera was to be used to examine the temperature of the filament/particle itself and the temperature field surrounding the particle/filament, as well as for measuring the surface optical properties as the temperature was increased through the melting temperature of boron oxide and the ignition temperature of boron. In addition, it was desired to utilize a high speed motion picture camera with filtering to measure the burning rate once ignition occurred.

## A. HEATER

A major effort of the present work was in developing an air heater. As mentioned above, the ignition temperature of boron at atmospheric pressure conditions is about 1900 °K. Initially, a vitiated air heater was considered to achieve this goal. This heater consisted of a stainless cylinder, 50.8 mm (2") O.D. and 304.8 mm (12") long (see Fig. 4). Hydrogen and air were mixed in the centrally located annular channel of the heater and ignited by a spark. Cooling air was provided from the outer annular chamber. A 7.7 mm O.D. by 0.1 mm thick by 200 mm long tantalum tube was placed in the center of the heater. The dry sample air passed through the hot tantalum tube and was heated by convection. The maximum combustion temperature that theoretically could be reached was about 2400 °K, at a fuel-to-air ratio of 32 (stoichiometric mixture of hydrogen and air). Unfortunately, the tantalum tube oxidized at too high a rate in the presence of oxygen, limiting the attainable air temperature for long term operation to 550 °K. Therefore, another alternative was chosen; an electric resistance heater.

Initially, a 0.2 mm diameter nichrome wire was manually wound as a 6" long, 3/16" diameter coil with 3" of straight wire left over on each end. This coil then was inserted into a zirconia ceramic tube (O.D. = 0.5", I.D. = 3/8"). The ceramic tube was previously cut into two pieces, one piece 6" long and the other 3". These two pieces were joined by a steel sleeve; therefore, one end of wire passed from the interface of the ceramic tubes through a hole in the steel sleeve. The dry air was guided by the 3" ceramic tube before passing through the hot coil. The two ends of the coil were series connected to a variable transformer. Varying the input air flow rate and/or the voltage

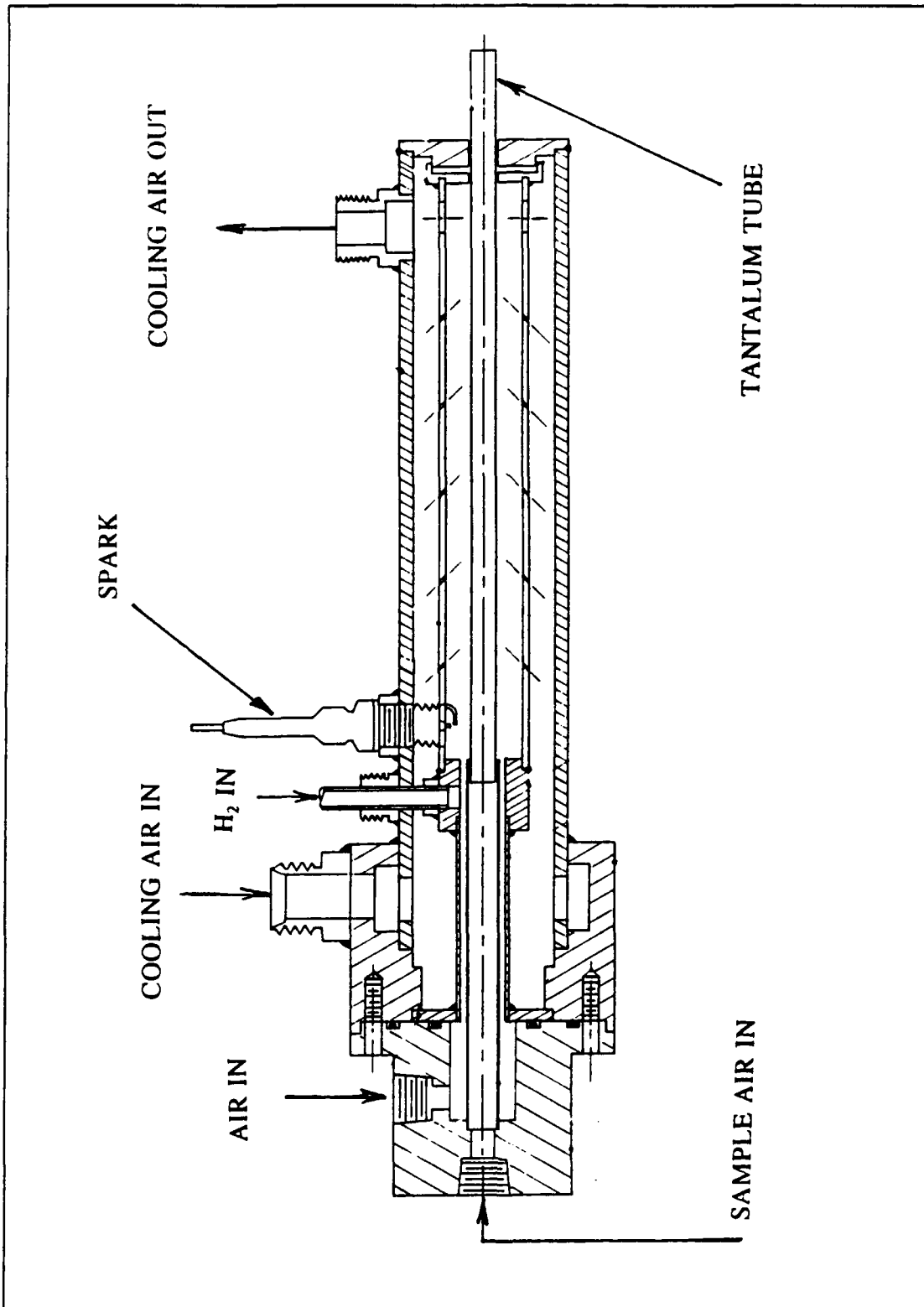

Fig. 4 Schematic diagram of the vitiated air heater

from the transformer controlled the output air temperature. The maximum output temperature 0.5" from the edge of this nichrome wire heater was measured at about 930 °K, which was close to the nichrome melting point of 1088 °K. Then the nichrome wire was replaced by a 24" long, 0.32" diameter platinum (+6% rhodium) wire which had a higher operating temperature (melting point about 2042 °K) and a higher unit price. By using the same technique as described previously, another electric heater was prepared for testing. Platinum wire is a very good conductor and, therefore, could not be heated sufficiently using resistance heating. However, the resistance of platinum wire increases with increasing temperature. Therefore, two electric heaters were joined in series, using the nichrome wire heater as a preheat stage. The hot air passing through the platinum wire heater increased the resistance of the platinum wire to the point where it could be resistance heated. The maximum obtainable output temperature of the two-stage heater was about 1150 °K, before the platinum wire failed. It was suspected that the platinum wire failed due to the presence of a notch on the inner surface of the coil which occurred when winding the wire. Obviously, the platinum wire had not failed due to reaching its melting point. Owing to time limitations, no further attempts were made to improve the heater design. Hence, the nichrome wire heater was used for the rest of the investigation. The maximum attainable temperature was 930 °K, restricting the investigation to measurements of the emittance of boron oxide through its' melting point.

## B. IR IMAGING SYSTEM

An AGEMA infrared imaging camera and microscope [Refs. 22,23,24] were used for obtaining the real-time images from the sample. This system consisted of a Thermovision 870 (scanner) with a microscope stage, plus an on-line IBM PC-AT computer for recording, displaying and analyzing the thermograms. The system is capable of measuring temperatures up to about 3000 °K with a measurement accuracy about  $\pm 4\%$  at 300 °K object temperatures and higher. The object radiation was detected by a mercury cadmium telluride detector mounted on a sapphire substrate. The detector is sensitive to radiation with wavelengths between 2 and 5  $\mu\text{m}$ . The standard image frame consists of 140x140 lines. Two modes of operation are possible; full frame and line-scan. The image may be taken at a speed of 2500 lines per second. It includes the ability to scan a single line at the same rate, which results in a measurement every 0.4 msec. The system is capable of sampling the whole frame at a rate of 25 Hz. The microscope [Ref. 24] can be focused to a 1.6x1.6 mm field of view (FOV) with an operating distance of 4 mm (i.e., the distance from the microscope head to the object surface). This results in a pixel-to-pixel distance of approximately 11.5 $\mu\text{m}$ . The microscope also has two optical paths, one infrared measurement path and a video channel for setting the correct distance to the object. The system utilizes a user defined emittance with the recorded energy to provide a temperature distribution on the object. The image emissivity can only be varied from 0.1 to 1. With this limitation the system cannot measure the emissive power of most gases, whose emissivities are far less than



0.1. The recorded images can then be manipulated using built-in software [CATS E, Ref. 22] and printed on a color printer.

### **C. HIGH SPEED MOTION-PICTURE CAMERA**

A 16 mm high speed motion-picture camera (HYCAM) can be used to record the behavior of the filament or the particle surface during ignition and combustion. The HYCAM is capable of taking 12,000 pictures per second. In order to obtain a picture of the burning sample, the sample is illuminated with an argon laser and viewed through a laser-line filter. Since the present heater could not heat the boron up to the ignition point, the HYCAM was not used in the present investigation.

### **D. EXPERIMENTAL APPARATUS LAYOUT**

The initial layout of the experimental apparatus is shown in Fig. 5. A 30 mm long boron filament was placed vertically in an insulating holder at 0.5" from the nichrome wire heater. The boron-carbide particle could be suspended with a vacuum on a small quartz tube and placed in a similar location to that used for the filament. A ceramic plate with a 1/8" diameter hole was placed between the microscope and the sample to protect the microscope head from excessive heat. A crystalline quartz window was placed over the hole and attached using ceramic cement. Since the focal length of the microscope was only 4 mm, the sample had to be placed nearly touching the ceramic plate. This resulted in not being able to place the heater parallel to the ceramic plate. To permit placing the sample in the center of the heated air stream, the electric heater was placed at a small angle relative to the ceramic plate. A fine-wire (0.005" diameter)

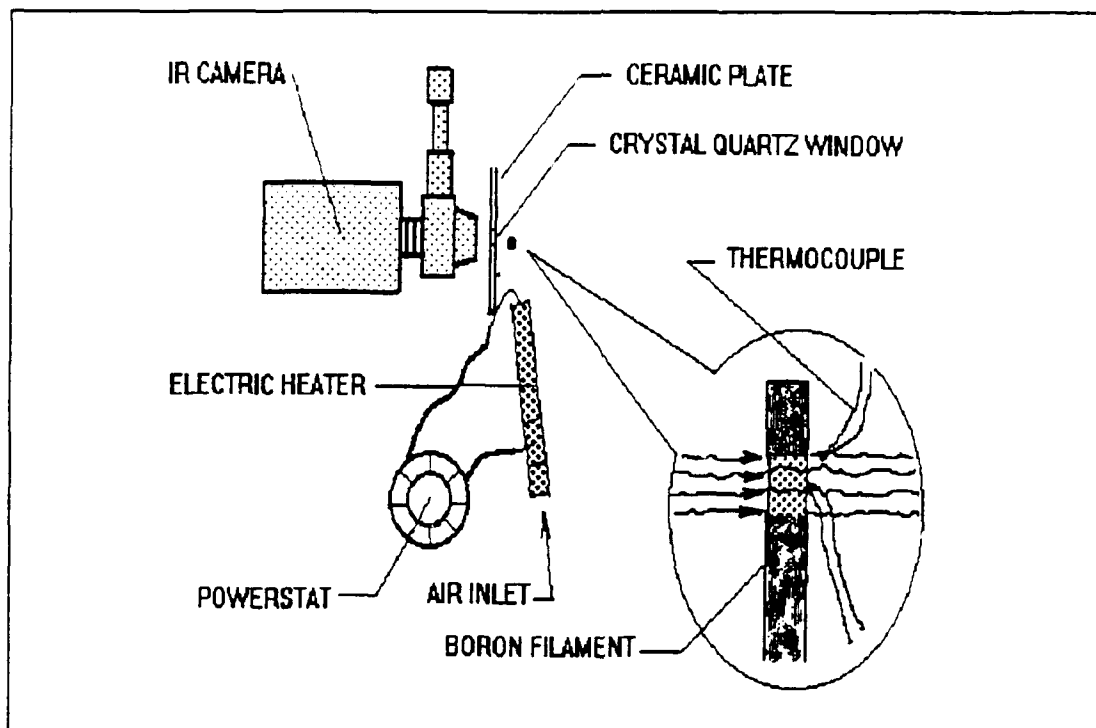

Figure 5. The initial layout of experimental apparatus

thermocouple (chromel-alumel) was used to measure the sample surface temperature. Another thermocouple was placed adjacent to the sample to measure the surrounding air temperature. With this layout, the data obtained was inconsistent. Several problems were identified. First, the quartz window did not pass all of the emitted energy in the 2-5 $\mu\text{m}$  range. This presented a problem since the optical properties of boron oxide are known to be wavelength dependent. Second, the glowing wire on the exit end of the heater generated a lot of radiation which was detected by scanner. Third, the thermocouple was not in solid contact with the boron filament surface. Therefore, an alternative test setup was used as shown in Fig. 6. The quartz window and ceramic plate were replaced by a sapphire window which passed all of the radiation in the 2-5 $\mu\text{m}$  range. Two sample configurations were used. A 1 mm long boron "cylinder" was held

firmly on the end of a small ceramic rod by a 0.003" diameter thermocouple placed around its surface. Moreover, a 20 mm x 20 mm, thin stainless steel shield was used to block the radiation from the heater to the scanner.

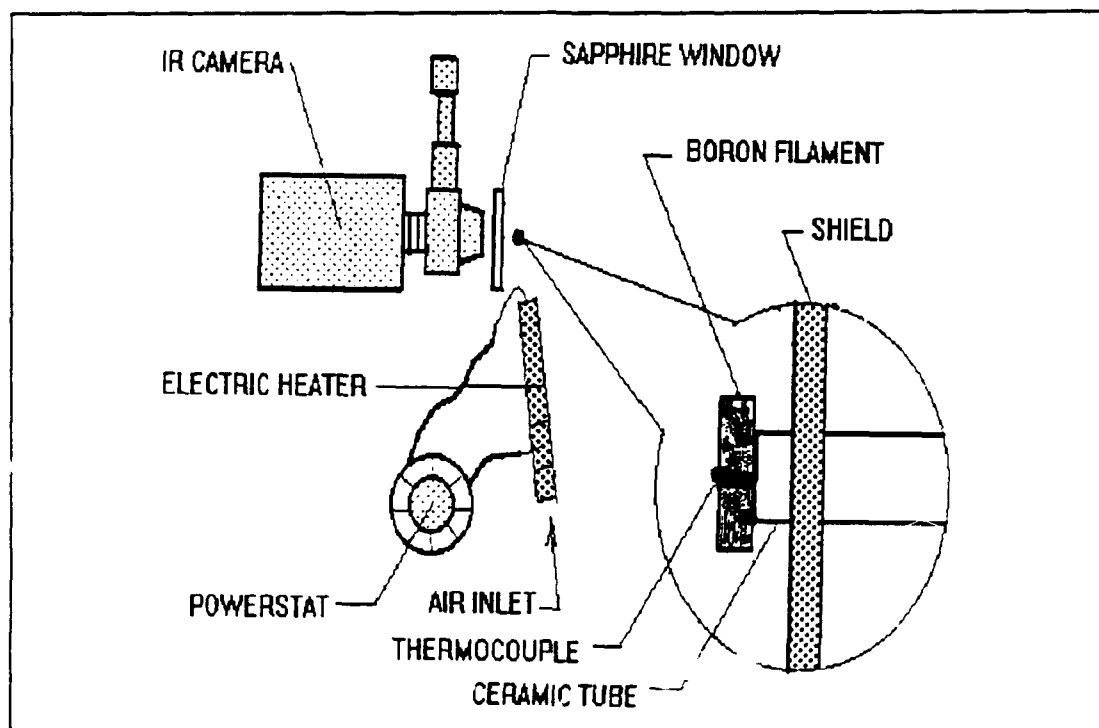

Figure 6. The final layout of experimental apparatus

The ceramic rod was used to insulate the heated filament and provide for the attainment of fairly uniform sample temperatures. The heater was placed close to the edge of the stainless steel shield to let the hot air pass on both sides of the shield. In one case the smooth cylindrical surface of the filament was observed. In the other case the rough end of the filament was observed. The flow rate of air through the ceramic tube was varied between 20 and 50 standard cubic feet per minute.

### **III. EXPERIMENTAL PROCEDURES**

The original objective of the investigation to use the IR microscope to observe boron filament and boron-carbide particle ignition and combustion processes was modified because of the inability to develop a suitable heater for the desired temperatures. The alternative objective of this study was focused on how the existing system could be used for evaluating the optical properties of boron oxide as a function of temperature to the melting temperature of  $B_2O_3$ .

#### **A. GENERAL OBSERVATION OF BORON FILAMENT**

A 0.29 mm diameter boron mono-filament (purchased from Goodfellow Co.) was used for all tests. The boron filament was quite brittle. Manually breaking the filament produces a coarse powder which has very sharp edges.

#### **B. RESISTANCE HEATING OF BORON FILAMENT**

Boron has a relatively high electrical resistivity, on the order of  $10^4$  ohm-cm at room temperature and has a high negative temperature coefficient of electrical resistance, a characteristic of semiconductors in general [Ref. 25]. A 50 mm long pure boron filament was series connected to an AC transformer to determine how it would respond to resistance heating. No surface temperature increase was measured when increasing the voltage. When the material reached its' breakdown voltage it suddenly ignited with

a bright light burst (at an input voltage of about 80 volts). Thus, to effectively heat the boron electrically, the boron will have to be deposited on a fine wire such as tungsten.

### **C. THERMOCOUPLE INSTALLATION**

To obtain emissivity as a function of temperature using the IR imaging system requires the accurate measurement of temperature. The initial idea was that one thermocouple could be imbedded in the surface of the boron filament, just out of view of the IR microscope. Another thermocouple was placed adjacent to the filament to measure the air temperature and the tip of this thermocouple was placed at the corner of the microscope image. The emissivity measurement area was isolated to a 1.6 x 1.6 mm region. It was found that maintaining firm contact of the first thermocouple with the filament was necessary to obtain consistent temperature data. Therefore, instead of "pushing" the thermocouple onto the filament surface, a more accurate method was found to be "pulling" the thermocouple into the boron oxide surface. A 0.003" diameter chromel-alumel thermocouple was passed through a two-hole, (40 mm long, 2 mm diameter) ceramic tube. A small piece of filament was fed through the tip of the thermocouple and then the thermocouple was pulled tightly to the filament. The diameter of the thermocouple only 1/4 that of the boron filament. This procedure produced repeatable temperature measurements of the surface of the boron filament.

### **D. WINDOW EFFECTS**

A 2" x 2" x 1/8" ceramic plate with a 1/8" diameter hole in the center was initially placed between the microscope and the boron filament to block the heat from the

microscope head. A 5 mm x 5 mm x 0.7 mm crystal quartz window was attached behind the hole using ceramic cement to allow the object radiation to reach the detector. It was found that the total emittance received by the IR camera from the boron filament surface was reduced about 20% at 350 °K. This resulted from the transmission characteristics of quartz as a function of wavelength. It does not effectively pass light between 2 and 5 microns in wavelength, which is within the sensitive range of the detector. Therefore, a 50.8 mm diameter, 1 mm thick sapphire window was used to replace the crystal quartz window and ceramic plate. Sapphire has a uniform transmission characteristic (about 80%) from 0.25  $\mu\text{m}$  to 5  $\mu\text{m}$ . Hence, the sapphire window should permit a better measurement than crystal quartz when using the AGEMA 870 system. The measured emittance of the boron filament was reduced by only 9% when using the sapphire at 350 °K and with the emissivity specified at 0.2. Table 2 presents the effects of the window material on the emittance of boron at 350 °K.

Table 2. Window material effects on measured boron emittance at 350 °K

Specified Emissivity		0.1	0.2	0.3	0.4	0.5
w/o window	W/m <sup>2</sup>	93	145	192	240	285
w/quartz	W/m <sup>2</sup>	71	118	164	210	253
	Reduction	24%	19%	15%	12%	11%
w/sapphire	W/m <sup>2</sup>	82	132	180	225	270
	Reduction	12%	9%	6%	6%	5%

## E. IR IMAGING SYSTEM OPERATING TECHNIQUES

In order to get the highest possible accuracy from the microscope thermal measurement, several important techniques should be utilized, some of which were not clearly specified in the operating manual. First of all, to bring the object into accurate focus was a challenge. The test sample had to be mounted on a micrometer stage to permit small adjustments in position. Focusing on the top surface or on the side of the 0.29 mm diameter filament produced significantly different results. The microscope focal distance is where the radiation measurement is made and is where the thermocouple contact point should be made. It was observed that at low temperatures the boron filament surface temperature was uniform over the surface due to low heat losses. As temperature was increased, the heat loss became significant and produced temperature gradients on the boron surface. When using the microscope, the field of view (FOV) setting in the system software should be "M16", which can be changed from "live mode" by typing the "LIDAT" command in the CATS E program. It will then write into PROM and the calibration constants will update automatically. The operation manual [Ref. 24] recommended only aperture 0 be used with the microscope, which is the most sensitive setting. Filters are required to operate at higher temperatures and they significantly affect the emissivity calculation as a result of their spectral transmission band (discussed below). The filters were fitted to a filter turret housed within the scanner unit. A maximum of two filters may be fitted into a revolving holder controlled at the rear of the scanner. A glass filter ( GLS ) and a flame filter ( FLM ) were used. The temperature range which can be measured using the IR camera with any given filter

depends upon the aperture setting and the specified surface emissivity. The lowest temperature is obtained with  $\epsilon = 1.0$  and aperture 0, whereas, the maximum temperature is obtained with  $\epsilon = 0.1$  (minimum value) and aperture 2 (maximum setting). The minimum and maximum temperatures for the present system were as follows: no filter, 262-817 °K; flame filter, 345-1857 °K; glass filter, 308-3139 °K.

For high accuracy, the measured area temperature should be averaged by integrating over the area for a period of time (approximately 100 scans). This can be achieved by using the "SHINT" command.



## IV. RESULTS AND DISCUSSION

### A. THE EMISSIVITY

The emissivity is an important factor in radiation theory which is required to describe the fraction of the radiant emittance of a black body produced by an object at a specific temperature. Expressed mathematically, this can be written as the ratio of the spectral emittance of the object to that of a black body as follows:

$$e_{\lambda} = \frac{W_{\lambda o}}{W_{\lambda b}}$$

From the Stefan-Boltzmann formula, the total emissive power is given by

$$W = \epsilon \sigma T^4 \quad [\text{Watts/m}^2]$$

where  $\sigma$  = the Stefan-Boltzmann Constant =  $5.7 \times 10^{-8}$  Watts/m<sup>2</sup> K<sup>4</sup>.

This formula states that the total emissive power of a gray body is proportional to the product of the  $\epsilon$  and the fourth power of its absolute temperature. In fact, the value for  $\epsilon$  obtained by using the Thermovision 870 system is an average value of  $\epsilon$  occurring over the infrared wavelength interval (2  $\mu\text{m}$  - 5  $\mu\text{m}$ ), and also includes any surface geometric effects. For this reason, it is best to use a surface that is flat, and uniformly in focus.

## B. THE EMISSIVITY OF BORON OXIDE

The emissivity of boron oxide was obtained with a small piece of boron filament (1 mm long, 0.29 mm in diameter) using the IR microscope. A very thin boron oxide layer coated the boron surface, with a melting temperature of about 720 °K. When the boron filament was heated by the dry hot air at 1 atm, it was necessary to insure that a steady-state was attained before taking data.

The emissivities obtained for boron oxide in the temperature range of 300 °K to 900 °K are shown in Figs. 7 and 8. The data in Fig. 7 was obtained when the IR microscope was focussed on the top surface of the boron filament in the lateral direction. The emissivity of boron oxide increased continuously from 0.5 to 0.8 as the temperature increased from 350 °K to 700 °K without using the filter (2 - 5  $\mu\text{m}$ ). Beyond this temperature range no image could be obtained without the use of filters. With use of the glass (GLS, 3.5- 5  $\mu\text{m}$ ) and the flame (FLM, 3.6-4.2  $\mu\text{m}$ ) filters, the emissivity dependence on temperature changed significantly. The emissivity decreased as temperature increased to approximately 650 °K. However, as temperature was increased beyond 650 °K the emissivity began to increase. It is interesting that the lowest emissivities obtained using the GLS and the FLM filter occurred near the boron oxide melting point. In addition, no significant change was observed on the boron filament surface from the IR image as the temperature reached the boron oxide melting point.

The reason for the above behavior was not initially clear. Thus, the emittances received by the IR camera when using the different filters were examined and are shown in Fig. 9. The data in Fig. 9 includes the corrections for the reduced transmittances

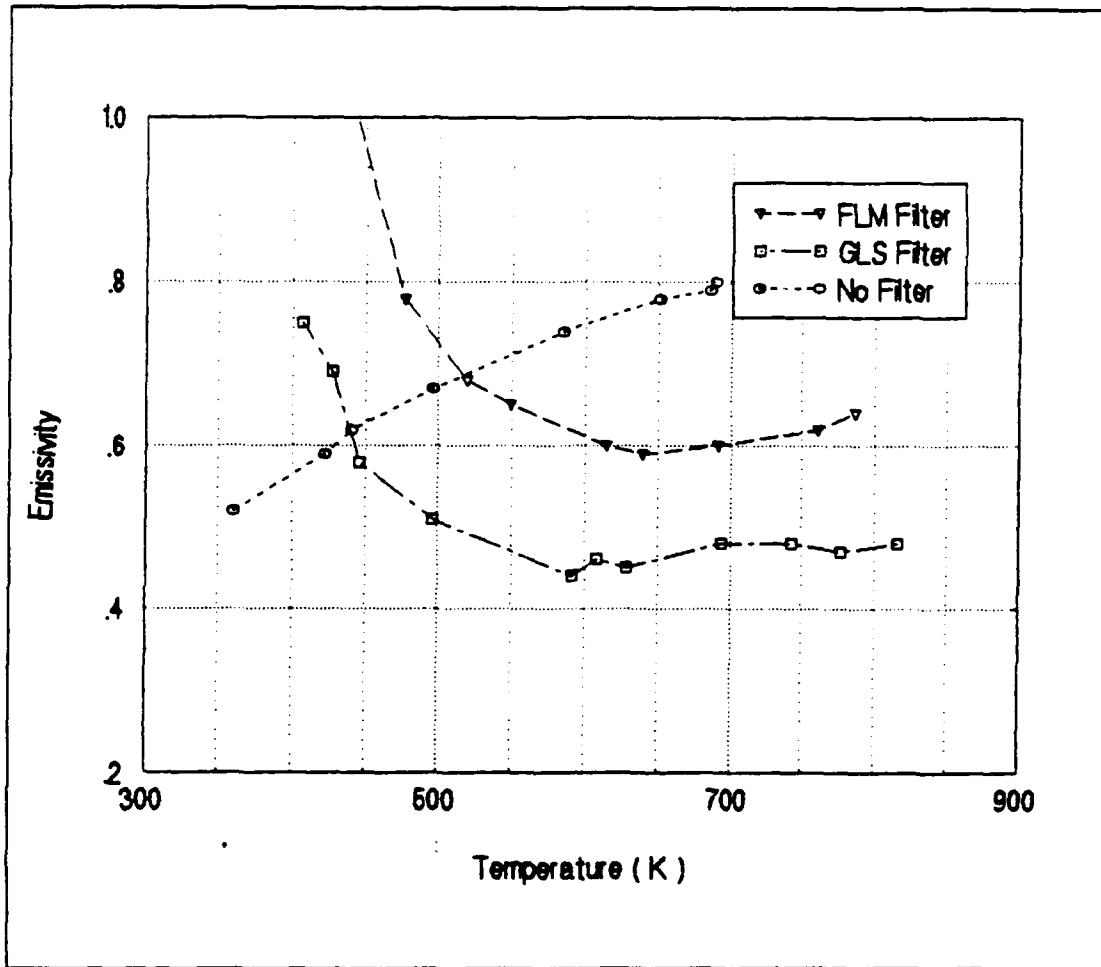

Figure 7. The averaged emissivity of boron oxide in 2  $\mu\text{m}$  - 5  $\mu\text{m}$  band in the lateral direction (smooth surface)

through the filters. It can be seen that the results were in good agreement.

The apparent reason for the effects of filter selection on emissivity seen in Fig. 7 and 8 is the variation of  $\text{B}_2\text{O}_3$  emittance with wavelength and temperature, coupled with the differences in (and overlapping of) band-pass for each filter (no filter = 2 - 5  $\mu\text{m}$ ; glass filter = 3.5 - 5  $\mu\text{m}$ ; flame filter = 3.6 - 4.2  $\mu\text{m}$ ).

Fig. 8 shows the  $\text{B}_2\text{O}_3$  emissivity received from the "end" of the filament. The results are similar to those in Fig. 7, but the values of emissivity are higher. The reason

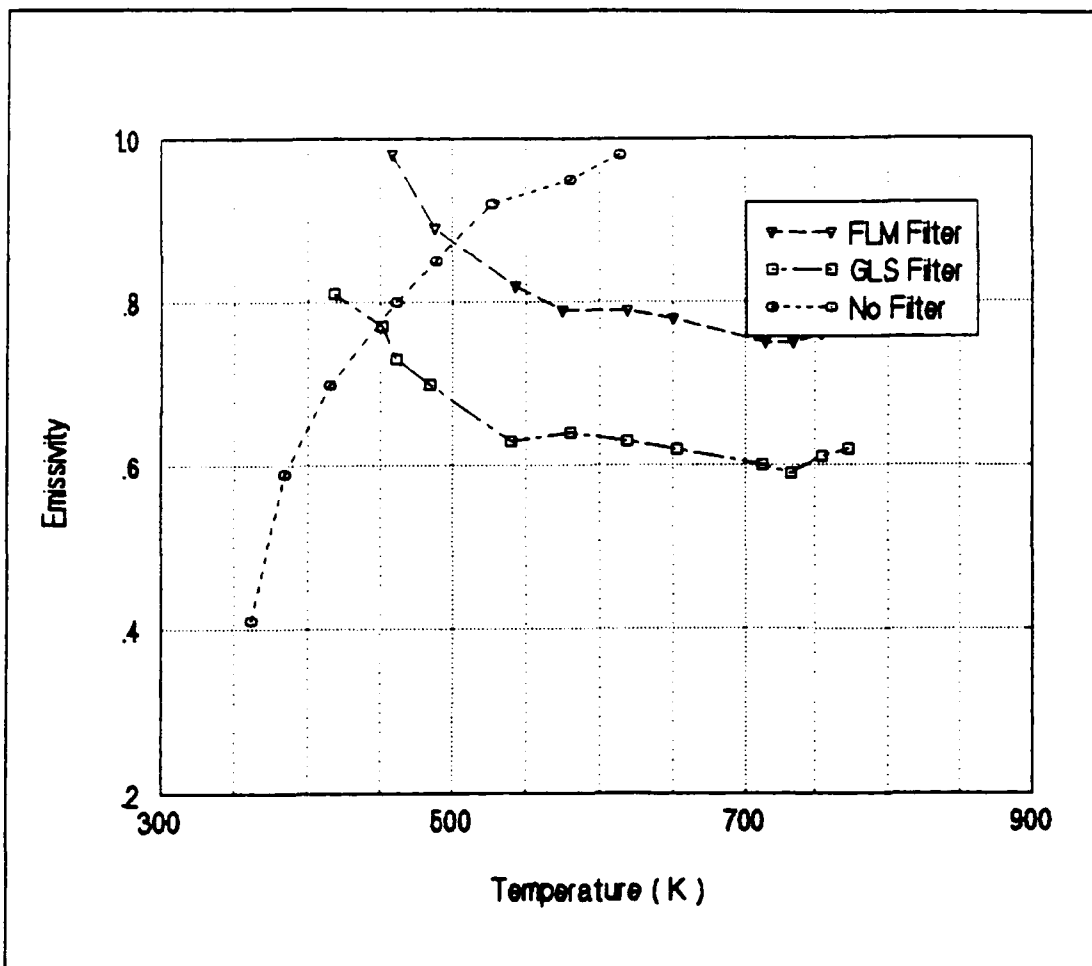

Figure 8. The averaged emissivity of boron oxide in  $2 \mu\text{m} - 5 \mu\text{m}$  band in the longitudinal direction (rough surface)

for the differences are due to the differences in surface configuration. The side of the filament presents a relatively smooth surface, but one on which it is difficult to focus due to the cylindrical surface and small depth of field of the microscope. The end of the filament was flat and more easily brought into focus, but had a much rougher surface.

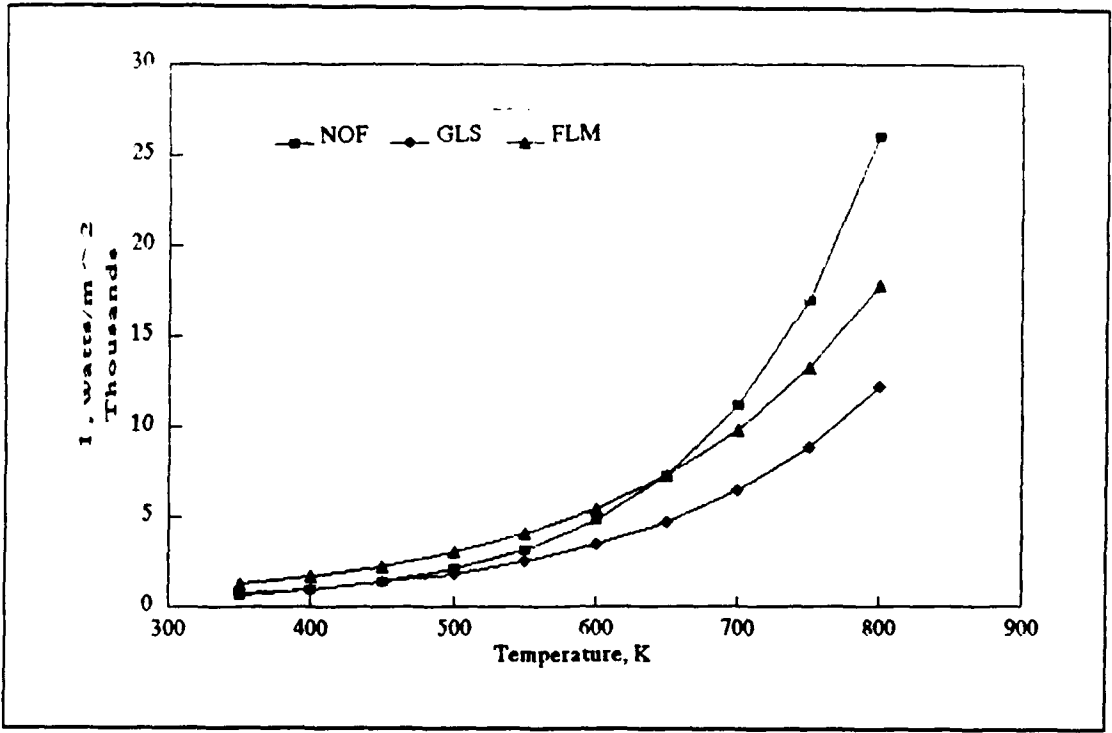

Figure 9. The radiation intensity of boron oxide

## V. CONCLUSIONS AND RECOMMENDATIONS

It was apparent from this investigation that it will be difficult to use the IR microscope system for obtaining the effects of both temperature and wavelength on the emissivity of particulate matter. Over a wavelength band the average emissivity can be determined, provide that the entire surface in the image is within the focal depth of the microscope and provided that an accurate surface temperature can be measured.

Coupled resistance heaters using nichrome for preheat and platinum for the final stage should permit heating of air to temperatures above the ignition temperature of boron ( ~ 1900 °K). Resistance heating of boron coated tungsten wire and/or laser heating from multiple sides of the particle/filament should also be considered.

The high speed microscope has proven to be a valuable new diagnostic tool for studying the behavior of metallized fuels. The effects of catalyst within the particle or surrounding gas can be readily studied for their resulting effects on self-heating and the ignition point.

## LIST OF REFERENCES

1. Talley, C.P., "Combustion of Elemental Boron", *Aero/Space Engineering*, Vol. 18, June 1959, pp. 37-47.
2. Karadimitris, A., Scott, C. II, Netzer, D. W. and Gany, A., "Regression and Combustion Characteristics of Boron Containing Fuels for Solid Fuel Ramjets", *J. Propulsion*, Vol. 7, No. 3, May-June 1991, pp. 341-347.
3. Natan, B. and Gany, A., "Ignition and Combustion of Boron Particles in the Flowfield of a Solid Fuel Ramjet", *J. Propulsion*, Vol 7, No. 1, Jan.-Feb. 1991, pp. 37-43.
4. Natan, B. and Netzer, D. W., "Experimental Investigation of the Effect of Bypass Air on Boron Combustion in a Solid Fuel Ramjet", *Second International Symposium on Special Topics in Chemical Propulsion : Combustion of Boron-Based Solid Propellants and Solid Fuels*, Lampoldshausen, Germany, March 4-6, 1991.
5. Maček, A. and Semple, J. M., "Combustion of Boron Carbide", *Final Report on Contract N00123-69-C-2365, April 1970, Atlantic Research Corp. Alexandria, Va.*
6. Maček, A. and Semple, J. M., "Combustion of Boron Particle at Atmospheric Pressure", *Combustion Science and Technology*, Vol. 1, 1969, pp. 181-191.
7. Mohan, G. and Williams, F. A., "Ignition and Combustion of Boron in O<sub>2</sub>/Inert Atmospheres", *AIAA Journal*, Vol. 10, No. 6, June 1972, pp. 776-783.
8. Turns, S. R., Holl, J. T., Solomon, S. P. and Faeth, G. M., "Gasification of Boron Oxide Drops in Combustion Gases", *Combustion Science and Technology*, Vol. 43, 1985, pp. 287-300.
9. King, M. K., "Ignition and Combustion of Boron Particles and Clouds", *J. Spacecraft*, Vol. 19, No. 4, 1982, pp. 294-306.
10. Holl, J. T., Turns, S. R., Soloman, S. P. and Faeth, G. M., "Ignition and Combustion of Boron Sulurry Agglomerates", *Combustion Science and Technology*, Vol. 45, 1986, pp. 147-166.

11. Hsieh, W. H., Peretz, A., Huang, I. T. and Kuo, K. K., "Combustion Behavior of Boron-Based BAMO/NMMO Fuel-Rich Solid Propellants", *J. Propulsion*, Vol. 7, No. 4, July-August 1991, pp. 497-504.
12. King, M. K., "Boron Ignition and Combustion in Air-Augmented Rocket Afterburner", *Combustion Science and Technology*, Vol. 5, 1972, pp. 155-164.
13. King, M. K., "Boron Particle Ignition in Hot Gas Streams", *Combustion Science and Technology*, Vol. 8, 1974, pp. 255-273.
14. Meese, R. A. and Skifstad, J. G., "Ignition and Global Combustion Models for Clouds of Boron Particles", *AIAA Journal*, Vol. 12, No. 1, Jan. 1974, pp. 71-77.
15. Zolotar, E. A. and Ozerov, E. S., "Calculation of the Ignition Limit of Boron", *Combustion, Explosive and Shockwaves*, Vol. 9, No. 4, 1973, pp. 446-450.
16. Grigor'ev, A. I., Sigimov, V. I. and Grigor'eva, I. D., "Ignition of a Solid Particle of Boron", *Combustion, Explosive and Shockwaves*, Vol. 10, No. 4, 1974, pp. 460-470.
17. Gaponenko, L. A., Biunovskii, S. N., Tulupov, Y. I. and Yakovleva, T. A., "A Model For the Ignition of a Single Boron Particle in a Medium Containing Water", *Combustion, Explosive and Shockwaves*, Vol. 17, No. 1, 1981, pp. 9-14.
18. Meinköhn, D., "The Ignition of Boron Particles", *Combustion and Flame* 59, 1985, pp. 225-232.
19. Turns, S. R., Holl, J. T., Solomon, S. P. and Faeth, G. M., "Gasification of Boron Oxide Drops in Combustion Gases", *Combustion Science and Technology*, Vol. 43, 1985, pp. 287-300.
20. Glassman, I., Williams, F. A. and Antaki, P., "A physical and Chemical Interpretation of Boron Particle Combustion", *20th Symposium (International) on Combustion*, The Combustion Institute, Pittsburgh, 1984, pp. 2057-2064.
21. Nelson, H. F. and Tucker, E. O., "Infrared Emission From Jet Engine Exhaust Plumes", *AIAA 24th Aerospace Science Meeting*, AIAA-86-0465, Jan. 6-9, 1986/Reno, Nevada.
22. "Thermal Image Computer TIC-8000 Operating Manual", Publication No. 556556883, Agema Infrared System AB, June 20, 1988.



23. "Thermovision 870 Operating Manual", Ed. 2, Publication No. 556804, Agema Infrared System AB, 1986.
24. "Infrared Microscope Manual for Thermovision 800", Rev. 3, Publication No. 556891, Agema Infrared Systems, June 29, 1989.
25. Talley, C. P., Line, L. E. Jr. and Overman, Q. D. Jr., "Amorphous Elemental Boron", *Boron Synthesis, Structure and Properties*, Plenum Press Inc., New York, 1960, pp. 94-104.

## INITIAL DISTRIBUTION LIST

1. Defense Technical Information Center 2  
Cameron Station  
Alexandria, Virginia 22304-6145
2. Superintendent 2  
Attn: Library, Code 52  
Naval Postgraduate School  
Monterey, California 93943-5000
3. Department Chairman, Code AA 2  
Department of Aeronautics and Astronautics  
Naval Postgraduate School  
Monterey, California 93943-5000
4. Professor D. W. Netzer, Code AA/Nt 2  
Department of Aeronautics and Astronautics  
Naval Postgraduate School  
Monterey, California 93943-5000
5. Dr. David Laredo 1  
Faculty of Aerospace Engineering  
Technion - Israel Institute of Technology  
Haifa 32000, Israel
6. Library Center 2  
Chung Shang Institute of Technology  
P. O. Box-2, Long-Tung, Taoyuan, Taiwan,  
R. O. C.
7. LCDR Yang Jen-Cheng 2  
121, 3F., Ming-Li St., Ku-Shan Dist.,  
Kaohsiung, Taiwan, R. O. C.