

(2-)
20

A TRIDENT SCHOLAR PROJECT REPORT

AD-A257 115

NO. 197



"THE INFLUENCE OF HEAT TREATMENT ON THE PERFORMANCE
OF HIGHLY CORROSION RESISTANT ALUMINUM ALLOYS"



UNITED STATES NAVAL ACADEMY
ANNAPOLIS, MARYLAND

This document has been approved for public
release and sale; its distribution is unlimited.

92-29338

U.S.N.A. - Trident Scholar project report; no. 197 (1992)

**"THE INFLUENCE OF HEAT TREATMENT ON THE PERFORMANCE
OF HIGHLY CORROSION RESISTANT ALUMINUM ALLOYS"**

A Trident Scholar Project Report

by

Midshipman Frederick G. Schenk, Class of 1992

U.S. Naval Academy

Annapolis, Maryland

Patrick J. Moran

**Adviser: Assoc. Prof. Patrick J. Moran
Department of Mechanical Engineering**

Accepted for Trident Scholar Committee

Francis W. Correll

Chair

8 May 1992

Date

DTIC QUALITY INSPECTED 4

Accession For	
NTIS CRA&I	<input checked="" type="checkbox"/>
DTIC TAB	<input type="checkbox"/>
Unannounced	<input type="checkbox"/>
Justification	
By	
Distribution/	
Availability Codes	
Dist	Avail and/or Special
A-1	

USNA-1531-2

REPORT DOCUMENTATION PAGE

Form Approved
OMB No 0704-0188

Public reporting burden for this collection of information is estimated to average 1 hour per response, including the time for reviewing instructions, searching existing data sources, gathering and maintaining the data needed, and completing and reviewing the collection of information. Send comments regarding this burden estimate or any other aspect of this collection of information, including suggestions for reducing this burden, to Washington Headquarters Services, Directorate for Information Operations and Reports, 1215 Jefferson Davis Highway, Suite 1204, Arlington, VA 22202-4302, and to the Office of Management and Budget, Paperwork Reduction Project (0704-0188) Washington, DC 20503.

1. AGENCY USE ONLY (Leave blank)	2. REPORT DATE 8 May 1992	3. REPORT TYPE AND DATES COVERED Final 1991/92	
4. TITLE AND SUBTITLE THE INFLUENCE OF HEAT TREATMENT ON THE PERFORMANCE OF HIGHLY CORROSION RESISTANT ALUMINUM ALLOYS		5. FUNDING NUMBERS	
6. AUTHOR(S) Schenk, Frederick G.		8. PERFORMING ORGANIZATION REPORT NUMBER U.S.N.A. - TSPR; 197 (1992)	
7. PERFORMING ORGANIZATION NAME(S) AND ADDRESS(ES) U.S. Naval Academy, Annapolis, Md.			
9. SPONSORING/MONITORING AGENCY NAME(S) AND ADDRESS(ES)		10. SPONSORING/MONITORING AGENCY REPORT NUMBER	
11. SUPPLEMENTARY NOTES Accepted by the U.S. Trident Scholar Committee			
12a. DISTRIBUTION/AVAILABILITY STATEMENT This document has been approved for public release; its distribution is UNLIMITED.		12b. DISTRIBUTION CODE	
13. ABSTRACT (Maximum 200 words) New "stainless aluminum" alloys must be produced using expensive processing methods such as co-sputter deposition and ion implantation. To determine the influence of temperature on the sputter deposited alloys heat treatments were conducted. These heat treatments caused pitting potential to decrease from the "as processed" values, but did not cause a total loss of corrosion properties relative to pure aluminum. Constant potential tests below the determined pitting potential were conducted on both heat treated and "as processed" sputter deposited alloys in an attempt to confirm the heat treatment data. Anodic currents were observed for both conditions. Some mechanical failure has been noted with these thin film alloys, which could result in crevice corrosion, possibly causing the anodic currents detected. This contradictory result requires further investigation.			
14. SUBJECT TERMS aluminum alloys - corrosion; aluminum alloys - heat treatment; corrosion resistant materials; sea-water corrosion		15. NUMBER OF PAGES 81	
17. SECURITY CLASSIFICATION OF REPORT UNCLASSIFIED		16. PRICE CODE	
		20. LIMITATION OF ABSTRACT	
18. SECURITY CLASSIFICATION OF THIS PAGE UNCLASSIFIED	19. SECURITY CLASSIFICATION OF ABSTRACT UNCLASSIFIED		

ABSTRACT

Aluminum and conventional aluminum alloys are used extensively throughout the Navy. Their application ranges from lightweight aircraft components to the superstructures on various ships. Though these alloys have good mechanical properties, they do not exhibit excellent resistance to corrosion in the marine environment. In an effort to alleviate these problems, transition metals, used to make stainless steels, have been alloyed with aluminum. These new "Stainless Aluminum" alloys cannot be produced by conventional alloying techniques because the alloying elements utilized have very low solubility limits in aluminum. Expensive processing methods such as co-sputter deposition and ion implantation must be used to produce alloys that exist in a supersaturated solid solution (the alloying element exceeding the solubility limit). Co-sputter deposition was used in this project to produce Al-8.5wt% Ta and Al-11wt% W thin film alloys. Potentiodynamic polarization experiments were done on the "as processed" alloys to determine their pitting potential. Large improvements relative to pure aluminum were achieved.

With the alloying element exceeding the solubility limit, these materials existed in a nonequilibrium state. Since the alloys would prefer to be in a two phase material, their behavior when exposed to elevated temperature is of interest. To determine the influence of temperature on the

sputter deposited alloys heat treatments at 200°, 300°, and 400° C for 30, 60, 180, 360, and 720 minutes were conducted.

These heat treatments caused the pitting potential to decrease from the "as processed" values, but did not cause a total loss of corrosion properties relative to pure aluminum. Scanning electron microscopy showed that the heat treatment resulted in the formation of second phase precipitates. It was determined that pitting attack occurred at precipitates, but not all precipitate sites experienced attack.

Bulk material produced through the rapid solidification process, spray forming, was evaluated. For both materials, Al-1.0 wt% Ta and Al-1.0 wt% W, it was noted that large precipitates, up to 5 microns, existed within the material. No corrosion improvement over pure aluminum was observed. Scanning electron microscopy showed that attack occurred around the precipitates like the sputter deposited samples.

Constant potential tests below the determined pitting potential were conducted on both heat treated and "as processed" sputter deposited alloys in an attempt to confirm the heat treatment data. Anodic currents were observed for both conditions. Some mechanical failure has been noted with these thin film alloys, which could result in crevice corrosion, possibly causing the anodic currents detected. This contradictory result requires further investigation.

TABLE OF CONTENTS

ABSTRACT.....1

INTRODUCTION AND OBJECTIVES.....4

BACKGROUND.....6

PROCEDURE.....29

RESULTS AND DISCUSSION.....45

CONCLUSIONS.....76

ACKNOWLEDGEMENTS.....79

REFERENCES.....80

INTRODUCTION AND OBJECTIVES

Aluminum alloys are used extensively in the United States Navy and range from lightweight, high strength aircraft components to large shipboard applications such as the superstructures on the Ticonderoga class cruisers. However, the corrosive marine environment has caused considerable problems with these conventional alloys because the elements typically added to aluminum to improve mechanical properties such as copper, magnesium, and zinc generally do not increase the corrosion resistance. In an effort to alleviate these problems, the Naval Research Laboratory and others have developed new high corrosion resistant aluminum alloys that have been termed "Stainless Aluminums" [6,7]. These alloys are composed of an aluminum matrix with elements such as tungsten or tantalum suspended in a supersaturated solid solution. The alloys exist in the supersaturated state because the solubility limits of tantalum and tungsten are very small in aluminum. Also, the superior corrosion properties are only achieved if the alloying element is kept in the supersaturated condition. To produce these types of alloys either a cold process or a rapid solidification process is needed. Some methods used to date are co-sputter deposition of thin film alloys and ion implantation [2,3,4,5,6,7]. Both of these processes have produced alloys that have shown the superior corrosion

properties. Co-sputter deposition has limited application because it produces very thin films, about one thousand angstroms, of the aluminum alloy on a substrate. Thicker deposits can be made, but the process is very difficult and expensive. Ion implantation, on the other hand, could be used to treat the surface of a large structure and "stitch" the alloying element into the aluminum exceeding the solubility limit. This, however, is an extremely expensive process and has only been done to small specimens. Both the co-sputter deposition and the ion implantation involve little or no heat generation, and thus do not allow the alloying element to precipitate into its equilibrium phase, thereby achieving the necessary supersaturated solid solution condition. Explosion compaction powder metallurgy and spray forming, two rapid solidification processes, have been used to make bulk material. The rapid cooling of the liquid metal could trap the alloying element in a supersaturated solid solution, and thus yield a bulk piece of material that exhibits the same properties as the cold processed specimens. Previous research has shown that the dynamically compacted material does not show any corrosion improvement, and in fact, exhibited properties similar to pure aluminum. The objectives of this project were two-fold. The first was to determine the influence of heat treatments at different temperatures for varying amounts of time on the corrosion resistance of the sputter deposited

Al-Ta and Al-W alloys. The second objective was to determine if spray forming, a rapid solidification process, would yield bulk alloys that exhibit the superior corrosion properties of the "Stainless Aluminums."

BACKGROUND

Aluminum, like all other metals, comes from an ore that is found within the earth. This thermodynamically stable ore is then processed by a refinery which adds energy to the elements, and a thermodynamically usable metal is produced. This piece of aluminum or aluminum alloy exists in an unstable phase, and thus will tend to revert to its stable form; in other words, it will corrode [9]. However, during this reaction with the environment the aluminum produces corrosion products, usually oxides, on its surface. These products will create a thin film and will generally inhibit the metal from reverting back to its thermodynamically stable state [9]. When this occurs, the metal is said to be passive. Presently, there are two accepted and debated definitions of passivity: 1) A metal is passive if, on increasing its potential to more positive values, the rate of dissolution decreases, exhibiting low rates at high potentials. 2) A metal is passive if it substantially resists corrosion in an environment where there is a large

thermodynamic driving force for its oxidation (known as thick film passivity). Different theories have been developed to prove each of the definitions, and some argue that it is the metal which determines the definition to be applied [9,12]. However, independent of which definition is chosen to explain the underlying mechanism of passivity, there is a certain phenomenology of active passive metals that can be shown [12]. This phenomenology is best shown by the polarization curve in Figure 1. This is a plot of the electrochemical potential versus the log of the current density for an active passive metal, like aluminum, in a solution of neutral pH. The current density is proportional to the corrosion rate. This means that the greater the current density, the faster the metal is corroding. The curve shows how the metal will react to an increasing potential [12]. In the lower region aluminum will freely corrode with an increase in potential. This is referred to as the active region. As the potential increases, the metal will reach a point (E_{pass} and I_{crit}) where the current density, which is directly proportional to corrosion rate, will fall off drastically to very low passive values (I_{pass}). This is the passive region. In this region, the film that has formed on the surface of the aluminum will protect the metal from corroding, and will reform rapidly if it should be scratched or damaged [1]. It is within this region that engineers attempt to keep aluminum so that it will not

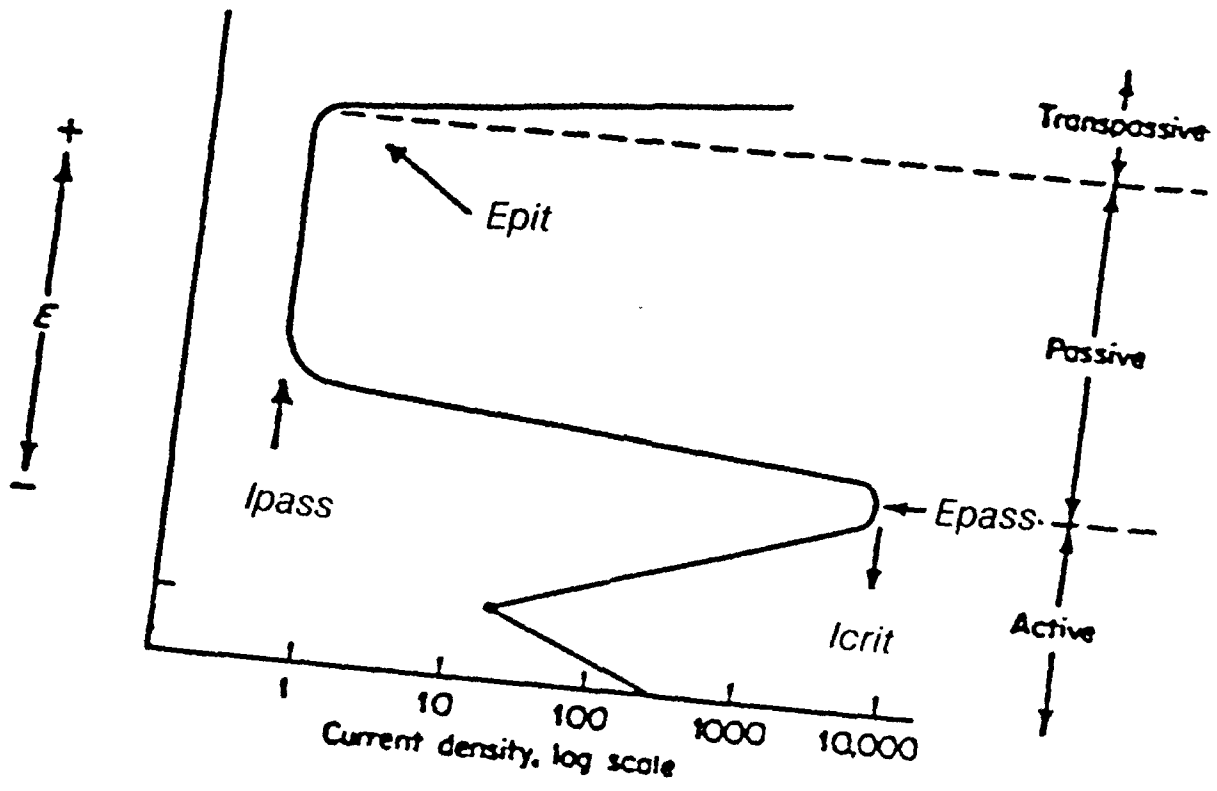

FIGURE 1: Typical behavior of an active-passive metal with increasing potential

corrode. As the potential continues to increase, the aluminum will generally reach a potential at which the passive film breaks down and pitting ensues (E_{pit}). This is termed the pitting potential. At potentials above the pitting potential the material is damaged by pitting.

The described parameters (E_{pit} , E_{pass} , I_{crit} , I_{pass}) characterize passivity, and depend on both the metal and the environment [12]. The presence of an oxidizer, such as dissolved oxygen, can cause aluminum to become spontaneously passive and thus will not exhibit the active region in Figure 1. The active nose of the polarization curve becomes hidden by the hydrogen evolution line shown in Figure 2 [12]. The polarization curve without the active region takes on a different shape, Figure 3. This is the shape of the curves that were generated during this study.

When the potential reaches E_{pit} , the passive film will break down and the sample will begin to corrode. The aluminum will not corrode uniformly over the whole surface, but will instead be subject to localized corrosion. The sample will be attacked at discrete sites where the passive film breaks down. The actual mechanism by which this happens is subject to much debate, but again the phenomenology has been well documented [9,12]. Since aluminum passivates, it is subject to a form of localized

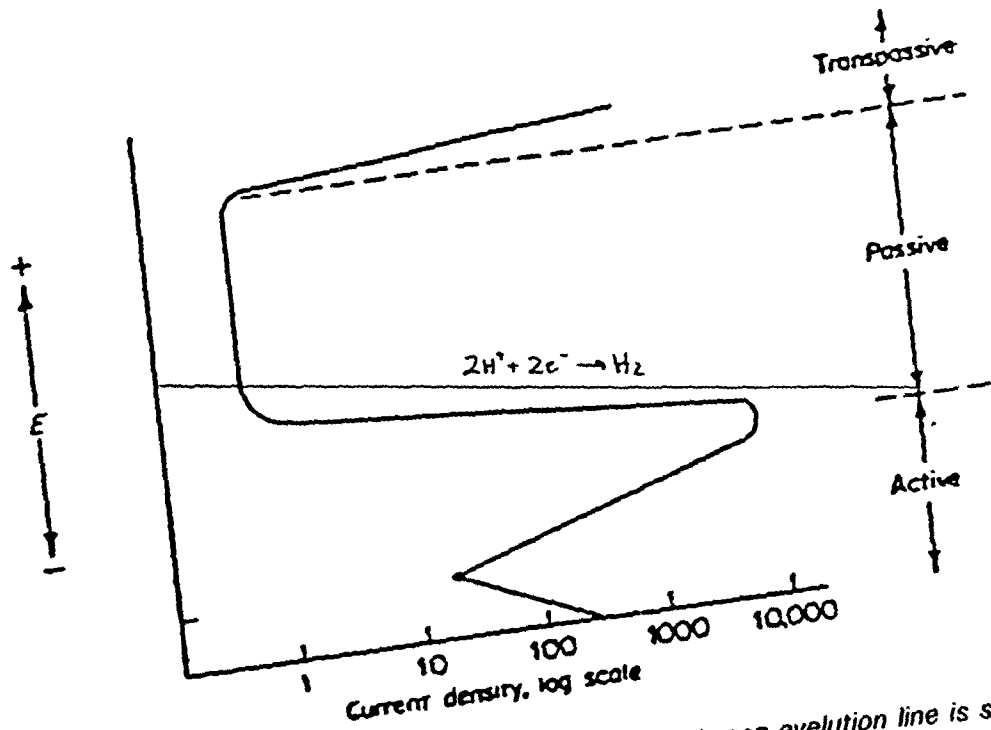

FIGURE 2: The location of the hydrogen evolution line is shown above the active region which causes the metal to spontaneously passivate

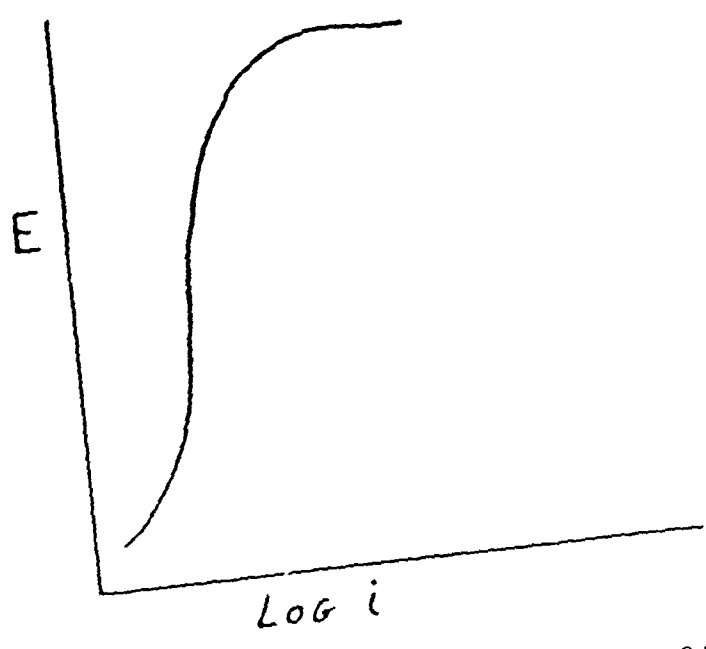

FIGURE 3: The shape of a polarization curve when the metal has spontaneously passivated

corrosion known as pitting. Pitting can be broken down into two phases: initiation and propagation. During the initiation phase, there is little or no change in the surface conditions. However, upon initiation of pitting, discrete sites of attack propagate and new sites continue to develop [12]. Some of the pits will repassivate, but others will continue to propagate into the aluminum and will eventually cause the piece to fail [10]. Though the initiation of pitting is a much debated issue, it is agreed upon that the local attack occurs at inhomogeneities on the metal's surface [12]. These imperfections could be either in the metal, in the film, or in the solution.

The environment, or solution, can have a dramatic effect on the pitting potential. Pitting is generally accelerated in an environment of aggressive chloride anions like the ocean [8]. For the two alloys studied in this project (Al-W and Al-Ta), the increase in chloride concentration in the solution has been shown to rapidly decrease the pitting potential. This effect has been determined to be a linear relationship for these alloys with Al-Ta having a slope much greater than 250 mV/percent of solute, and the Al-W alloy having a slope of approximately 550 mV/percent of solute [4]. For naval applications, aluminum is often coupled with steel. This electrical contact between the two metals causes a galvanic couple to form. This galvanic couple can affect the passivity of the

aluminum in one of three ways: "1) increasing the potential so that passivity can occur for conditions under which it otherwise would not, 2) increase the potential to the point that localized corrosion can occur, and 3) decrease the potential so that passivity cannot be maintained and active dissolution occurs on the (previously) passive metal" [12]. These three cases are shown in Figures 4, 5, and 6. Two of these three cases are detrimental to the passivity of the aluminum. Unfortunately, the aluminum steel galvanic couple falls under case 2. This is shown by the use of the galvanic series, Figure 7, which shows the rest potential or E_{corr} of different metals and alloys in the ocean environment. From this series, the rest potential of steel ranges from -700 mV to -550 mV; the rest potential of aluminum alloys ranges from -1000 mV to -750 mV. These are shown in Figure 8. When these two metals are electrically connected, they form a galvanic couple which will achieve a rest potential around -700 mV depending on the area ratio. This is the approximate pitting potential for aluminum and conventional aluminum alloys in a 3.5 wt% NaCl solution. This means that the couple will likely cause the aluminum to move out of the passive region and begin to pit. If the pitting potential of the aluminum alloy could be increased to a value higher than -700 mV, such as -550 mV, then the aluminum alloy would remain in its passive region and would not corrode. This has been accomplished with the new

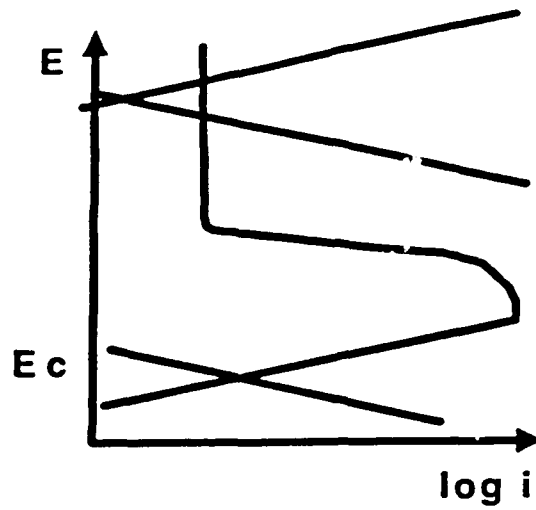

FIGURE 4: *A galvanic couple which increases the potential and pulls the active-passive metal into the passive region*

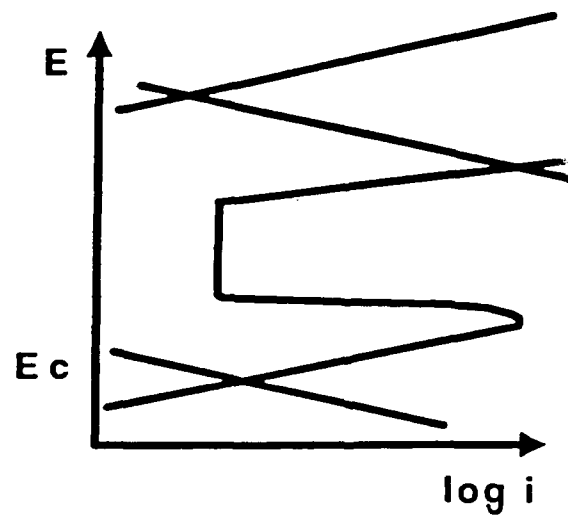

FIGURE 5: *A galvanic couple which increases the potential and pulls the active-passive metal into the region where it will corrode*

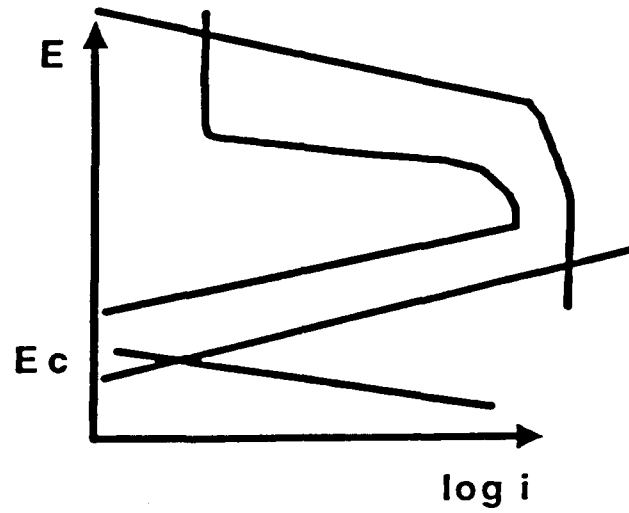

FIGURE 6: *A galvanic couple which decreases the potential and pulls the active-passive metal down into the active region.*

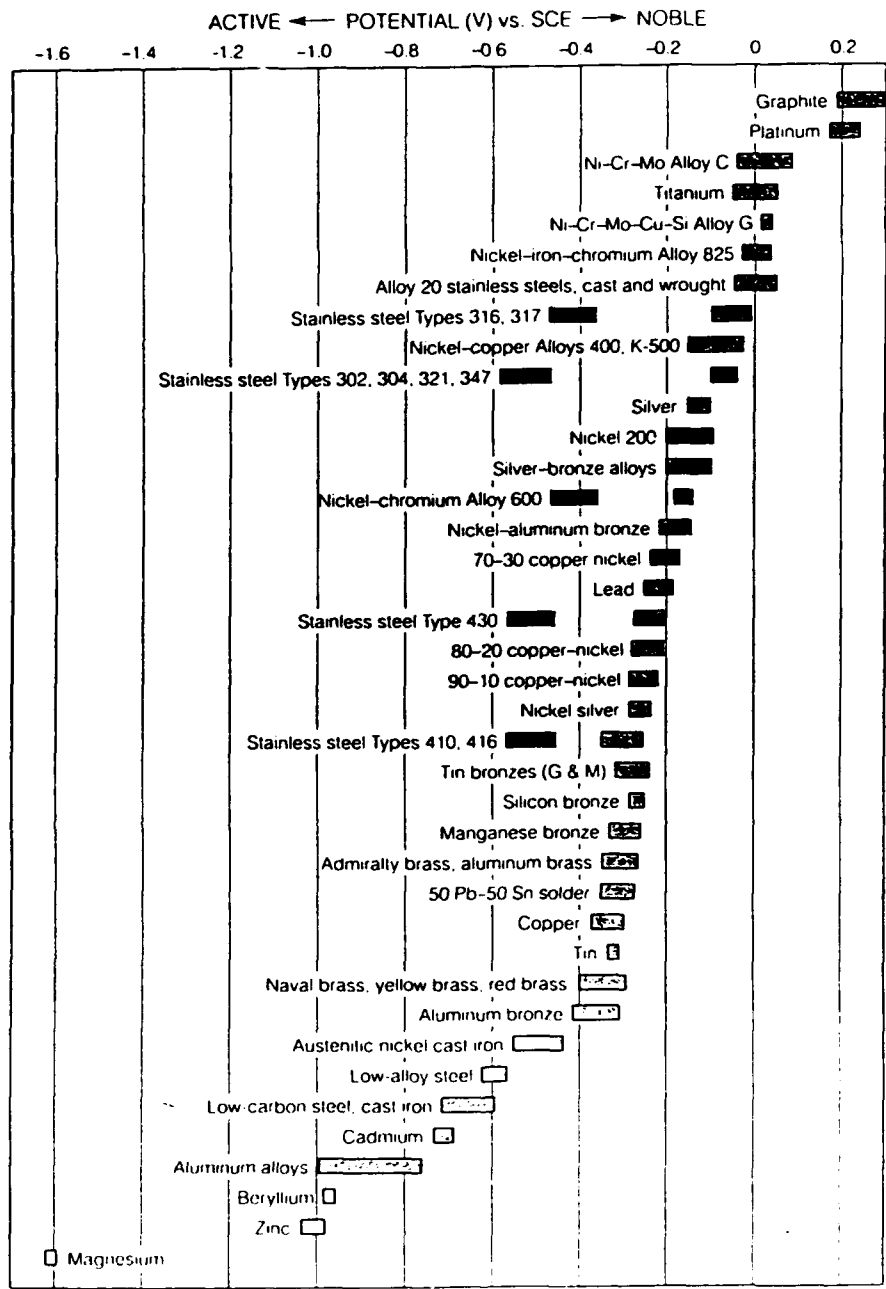

FIGURE 7: Galvanic Series showing the range of E_{corr} for various metals and alloys in seawater.

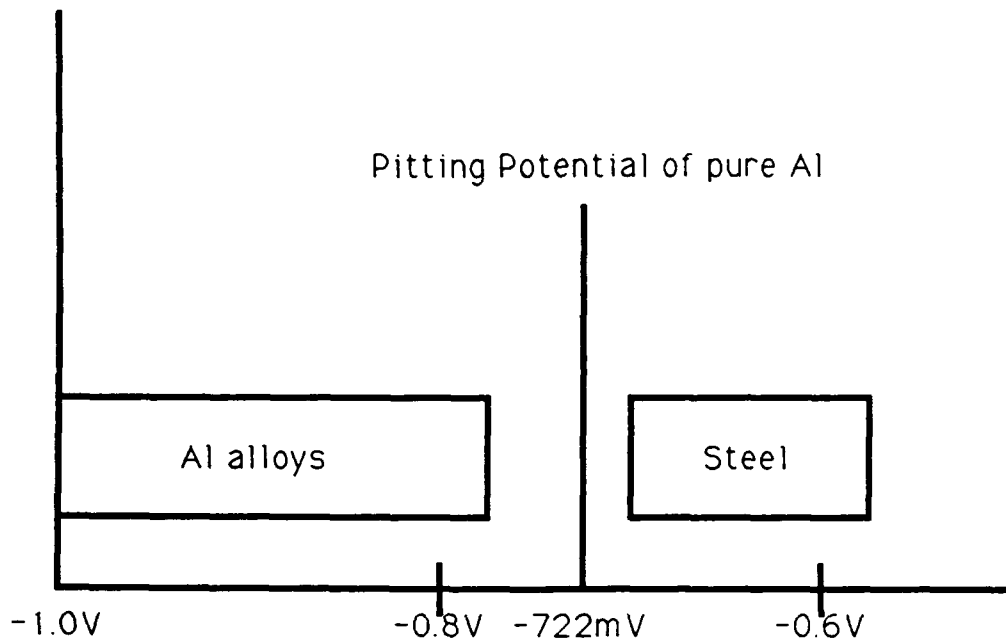

FIGURE 8: *This diagram shows the ranges of E_{corr} for aluminum alloys and steel in seawater.*

"Stainless Aluminum" alloys as will now be discussed.

The new "Stainless Aluminum" alloys that have been developed to alleviate the corrosion problem in the marine environment have been researched extensively by Martin Marietta Laboratories in Baltimore, Maryland, and by the Naval Research Laboratory in Washington, DC. The funding for these efforts has been through the Office of Naval Research. Martin Marietta has produced several different supersaturated solid solution aluminum alloys by co-sputter deposition in order to analyze which alloy would exhibit the highest pitting potential. The elements that have been introduced into aluminum are the same elements that have been used to produce stainless steels, thus giving the new aluminum alloys the name "Stainless Aluminum" [5]. These transition elements, such as Mo, Ta, W, and Cr, are not usually alloyed with aluminum because of their very low solubility limit, less than 1 at.%. "However, the amount of solute in solid solution can be increased, by several orders of magnitude, and corrosion performance significantly enhanced if the alloys are produced using nonequilibrium alloying methods" [5].

The Naval Research Lab (NRL) has used the process of ion implantation to produce the "Stainless Aluminums". This is different from the sputter deposition process used by Martin Marietta in that "ion implantation offers a method of producing solid solution surface alloys unattainable by

conventional alloying techniques" [6]. Ion implantation is a line of sight process where atoms of a particular element are ionized, focused into an ion beam, accelerated, and then bombarded into a host material, Figure 9. Though expensive, ion implantation is a very versatile process. Any solid material can be used as a host material, including metals, semiconductors, and insulators, and almost any element from hydrogen to uranium can be implanted [6,7]. The elements can be driven into the host material to depths of 100 to 10000 angstroms, and the concentration can be varied from trace amounts to 50 atomic percent [6,7]. Ion implantation offers several advantages over other techniques: 1) No sacrifice of bulk properties, 2) Low temperature process, 3) Solid solubility limit can be exceeded, 4) No change in sample dimensions, 5) Depth-concentration distribution is controllable, 6) Precise location of implanted area [6,7]. Presently, ion implantation has only been done on small samples due to the constraints of the apparatus. However, this process does have the potential to be applied to large structures such as aircraft, or shipboard components.

A supersaturated solid solution occurs when a metal is alloyed with an element to a concentration beyond the solubility limit in such a way that the alloying element does not precipitate out as a new phase. This is shown by the phase diagram of tantalum and aluminum shown in Figure 10, with tantalum having a solubility limit of 0.25 wt% in

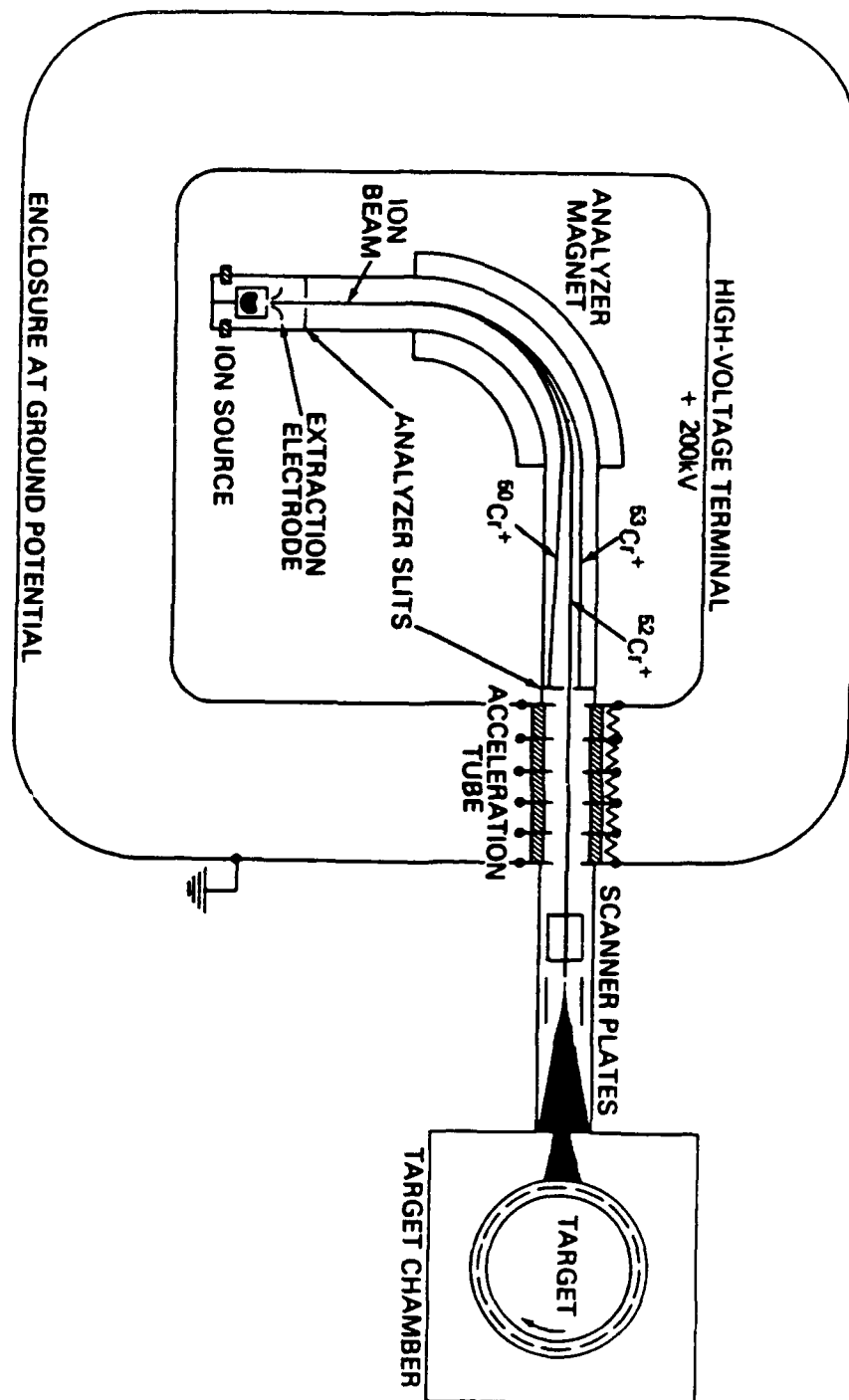

FIGURE 9: A schematic of the Ion Implantation process.

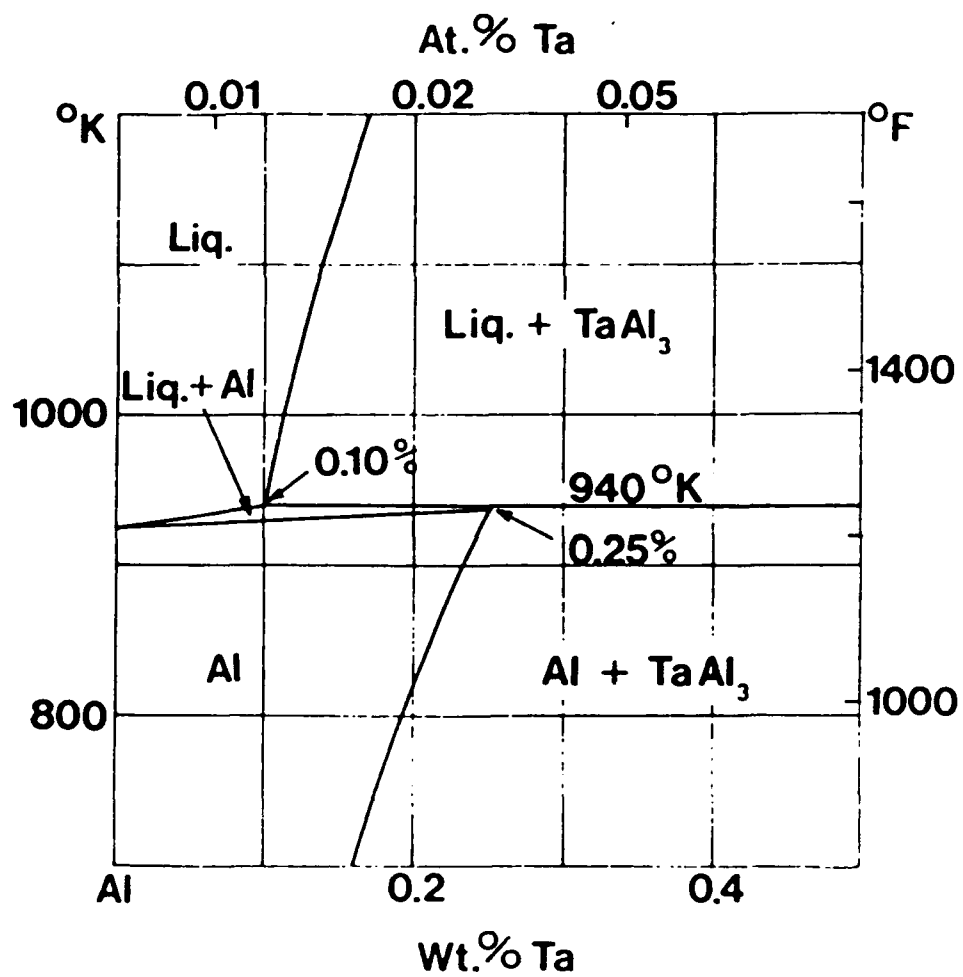

FIGURE 10: *The phase diagram of Al-Ta. Note*

the very low solubility limit of tantalum in aluminum.

aluminum at approximately 675 C (1250 F) [11]. If 5 wt% of tantalum in aluminum is chosen, it is easily seen that this exceeds the solubility limit. In order to make a supersaturated solid solution, a process must be used to trap the alloying element in the aluminum matrix. This can be attempted by either heating the alloy up to the point where it becomes a liquid, point B, and then rapidly cooling it as to not allow the second phase to precipitate, or by a cold processing method such as sputter deposition. From the phase diagram it can be seen that the supersaturated solid solution is not the equilibrium state of the alloy. It would prefer to exist as a two phase material.

For the sputter deposited alloys, both the Al-W and the Al-Ta resist corrosion in a similar matter. In each case "surface analysis of the passive films formed on these alloys revealed that they become enriched in oxidized solute as the specimen is anodically polarized. In general, the oxidized solute protects the substrate by restricting the ingress of chloride and thereby preventing localized attack" [4]. The two alloys that exhibit the highest pitting potential were Al-W and Al-Ta shown in Figure 11. This figure shows that Al-Ta alloys pit between 0 and 100 mV in aerated 0.1M KCl solution, and Al-W showing pitting potentials as high as 1900 mV. The polarization curves also show that the pitting potential of the Al-W alloys increases with increasing concentration of tungsten.

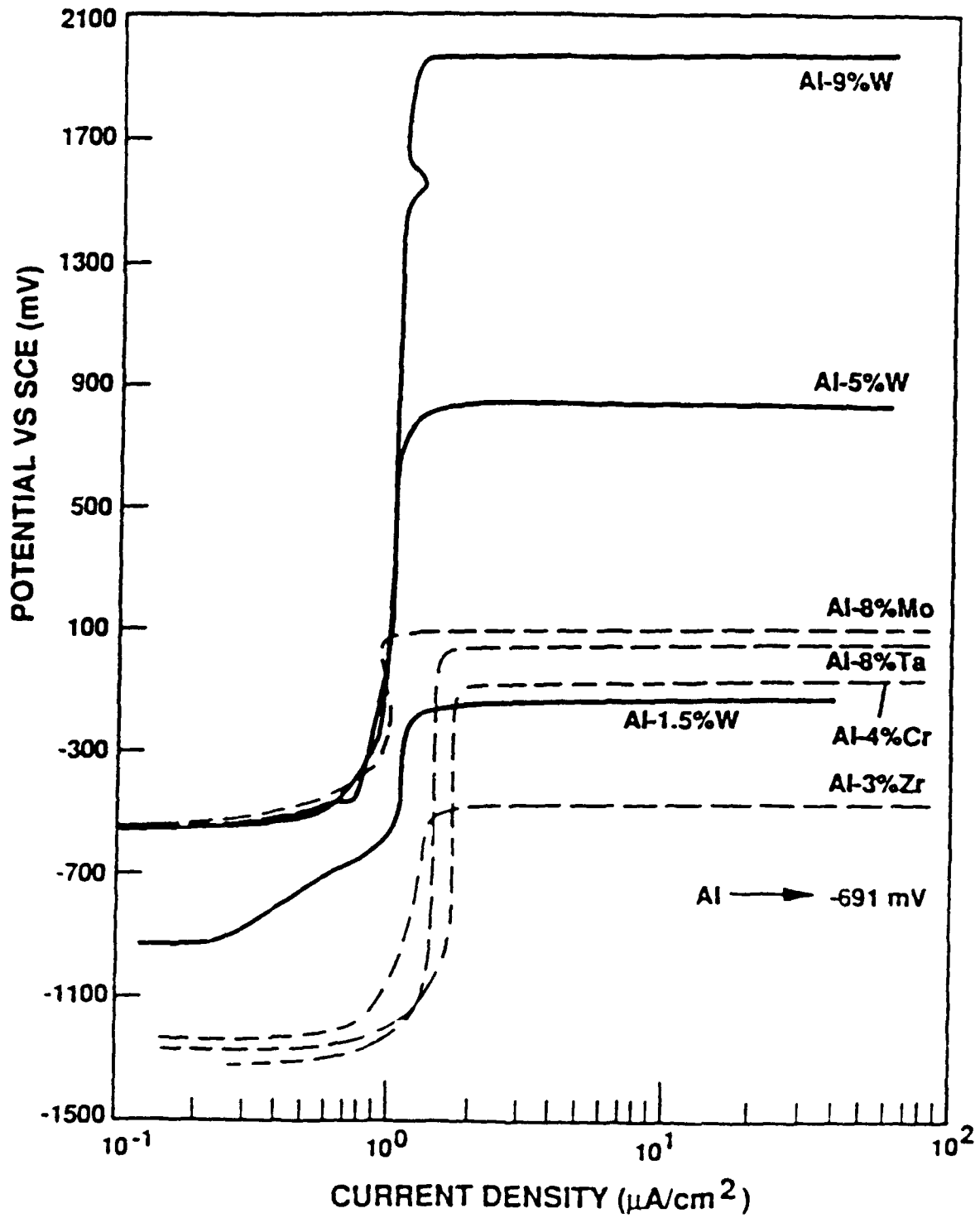

FIGURE 11: A plot of polarization curves for various sputter deposited aluminum alloys in 0.1M KCl solution.

Since the rapid solidification of explosion compaction powder metallurgy did not show the improved corrosion properties that the "Stainless Aluminums" did, another rapid solidification process, spray forming, was examined in this project. This process consisted of first melting the alloy in a crucible, and then spraying the atomized material on a moving substrate, Figure 12. Two specific alloy compositions were spray formed at the University of California, 1 wt% tantalum in aluminum and 1 wt% tungsten in aluminum [10]. Spray forming was chosen for three reasons. First, this process has led to improvements in mechanical properties and the microstructure in various alloys, especially reactive metals like aluminum. Second, spray forming is cost effective compared to the techniques described above. Third, spray atomization and deposition has never been done on Al-Ta and Al-W alloys before, and the corrosion properties of these materials are unknown [10]. Scanning electron microscopy had already been done on the four spray formed samples, and showed that the alloying elements had in fact precipitated out of the aluminum. The precipitates were approximately one to five microns in size and were spread throughout the material, Figure 13. This meant that the alloy probably did not exist in a supersaturated solid solution.

Since the Al-W and Al-Ta alloys are fabricated in nonequilibrium supersaturated solid solutions, the stability

SPRAY FORMING

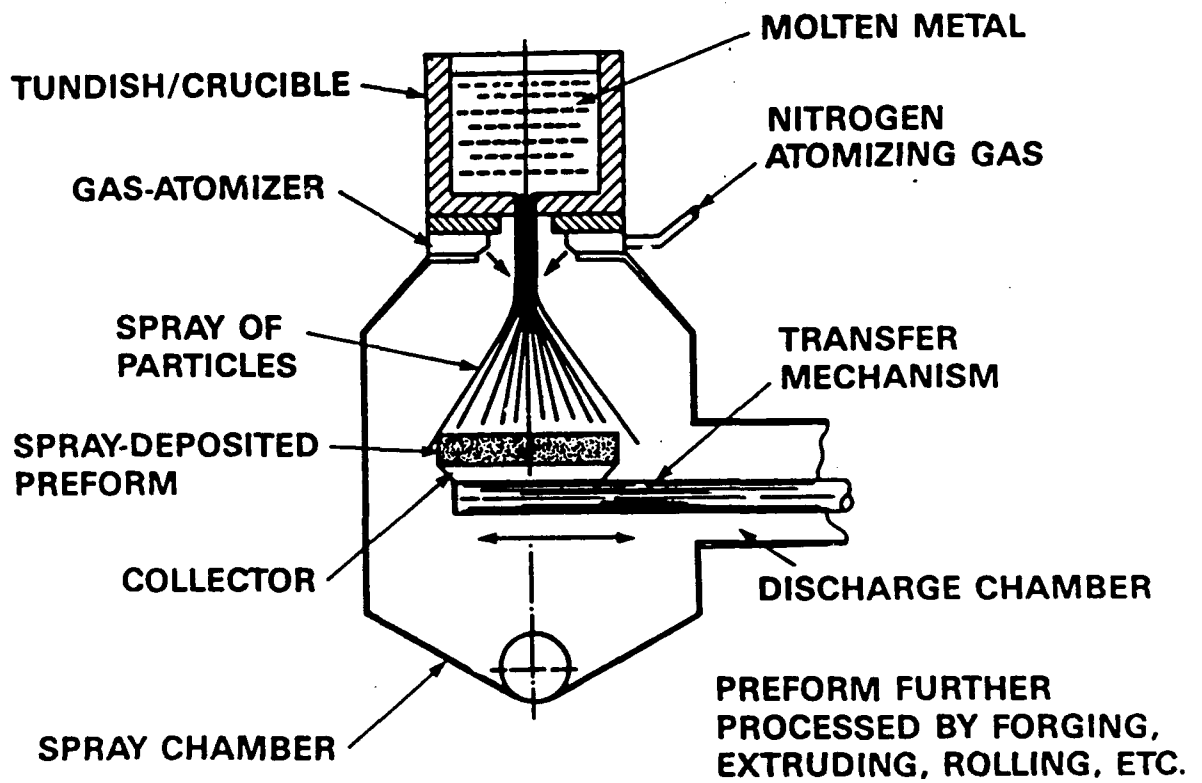

FIGURE 12: *A schematic of the spray forming process.*



FIGURE 13: *A SEM photograph showing large precipitates, up to 5 microns, on the surface of the spray formed material.*

of the alloys needed to be examined. A critical question is whether time and/or temperature would promote precipitation of the second phase, and diminish the corrosion properties. Martin Marietta characterized samples immediately after they were sputtered, and again after one year of being maintained at room temperature. No precipitation of the second phase was noted in the Al-W and Al-Ta alloys [2,3,4,5]. It was determined that the precipitation of the second phase would be detrimental to the corrosion properties of the material. To prove this, and to see just how much the alloys would be affected by the second phase, heat treatments were done at 400 C for one hour and twenty-four hours. The only alloys to retain some of their corrosion properties after the heat treatment and the formation of an intermetallic phase were the Al-W and Al-Ta alloys. The Al-W alloy still had a small passive region of 200 to 300 mV shown in Figures 14 and 15 [3,5]. This limited study has been the only work reported on the influence of heat treatment on the corrosion properties of "Stainless Aluminum" alloys prior to this Trident Scholar report.

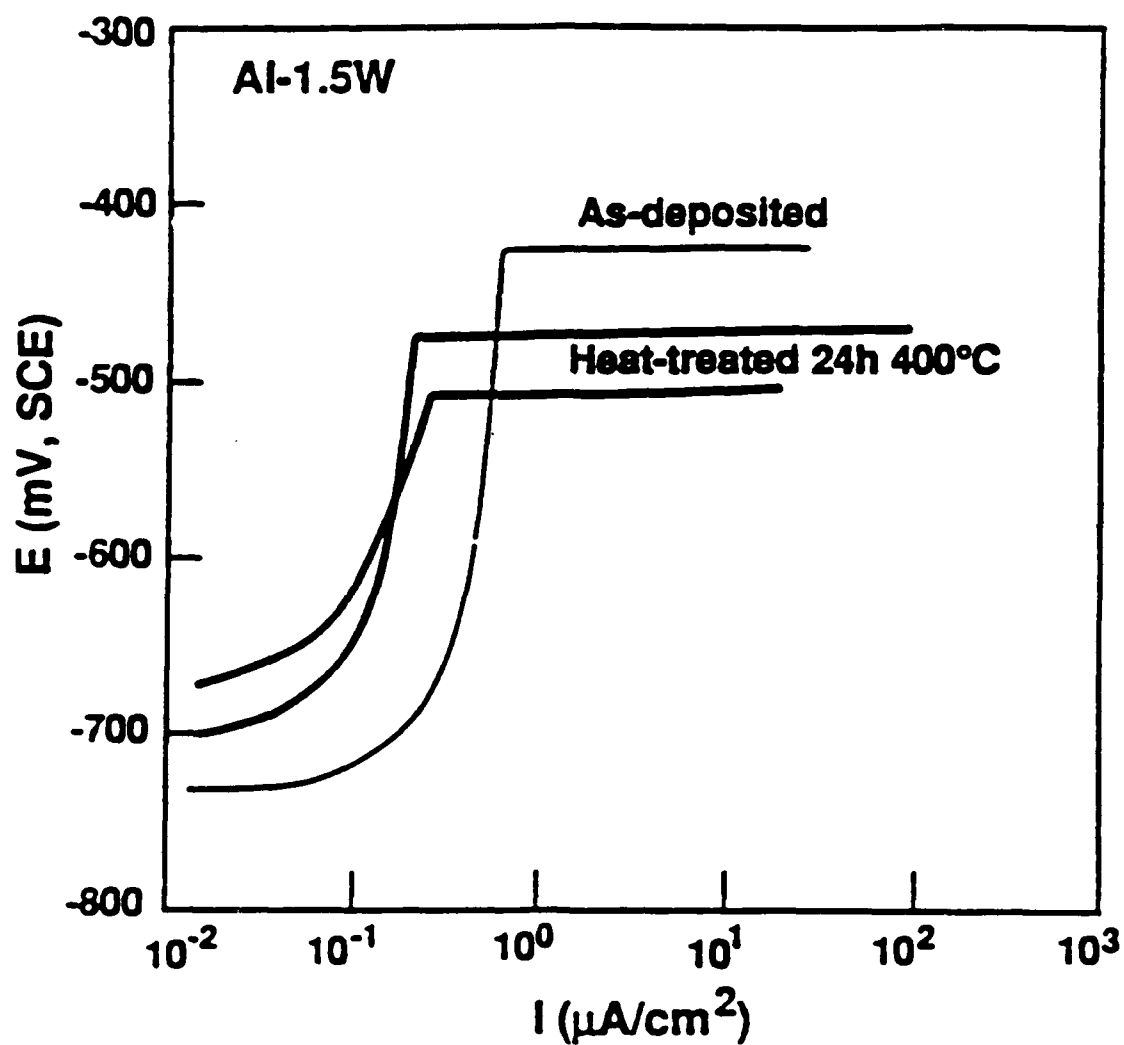

FIGURE 14: A polarization curve showing the effects of a twenty-four hour heat treatment on the same material as compared to the as-deposited. Experiment was done in 0.1M KCl solution.

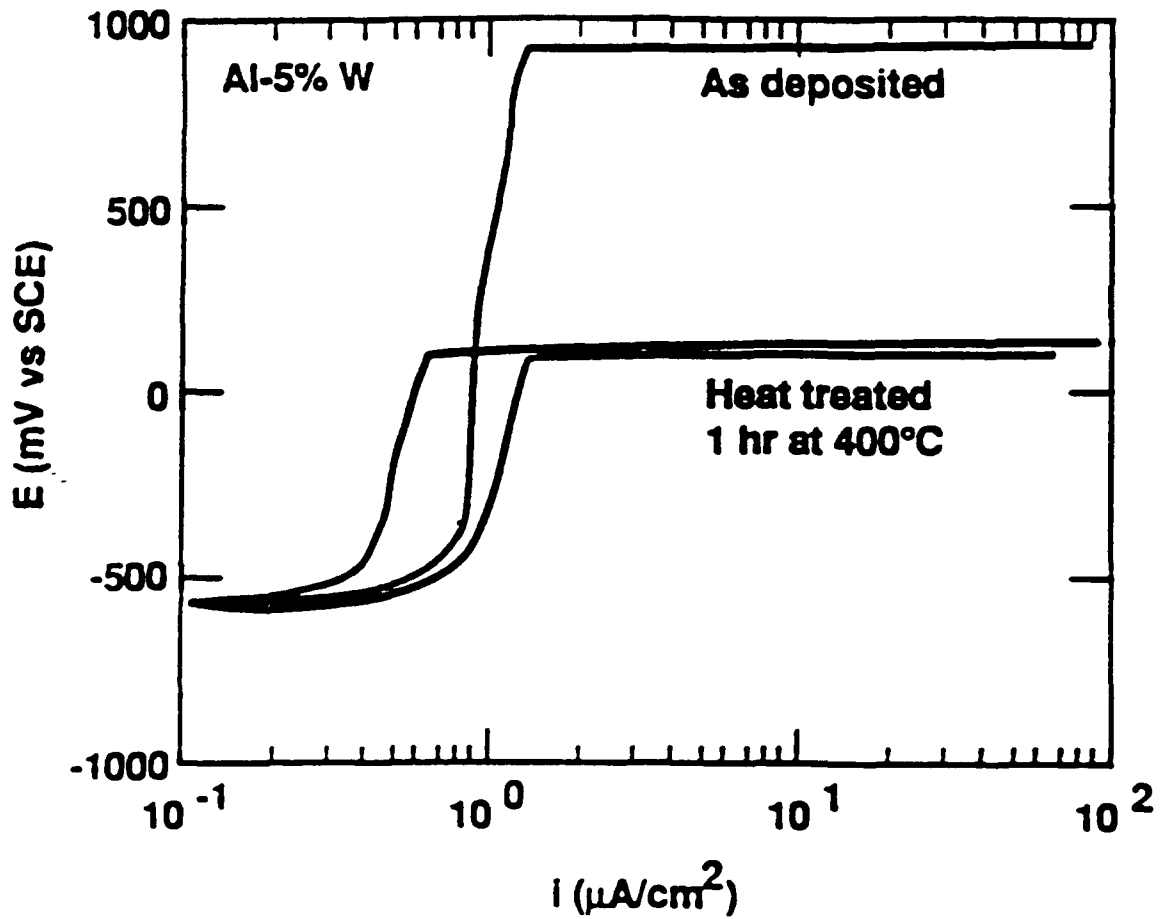

FIGURE 15: A polarization curve showing the effects of a one hour heat treatment as compared to the as-deposited material.

Experiment was done in 0.1M KCl solution,

PROCEDURE

The first step was to identify the pitting potential of pure aluminum and three conventional aluminum alloys in a 3.5 wt% NaCl solution. To do this, a mounted 99.999% pure aluminum sample was obtained from The Johns Hopkins University, and three conventional bulk alloys, 6061-T6, 7075-T6, and 2024-T4, were mounted using a hot process. A hot mount could be used on these conventional alloys because they are not in a supersaturated solid solution, and thus elevated temperature would not affect their corrosion properties. The three alloys were first cut into small pieces using a Leco model CM-12 cut saw. The small chunks were placed into a Buehler Simplimet II mounter along with a Buehler Green Phenolic Premold on top. The press was preloaded to 29 MPa, and the heat was applied. Once the pressure went to zero the heat was removed and the heat sink was put in place to quickly cool the samples down. The samples were removed after cooling, and then were polished (polishing details are given later in this section). The next step was to attach a 24 gauge wire so the electrical connection could be made. A small hole was drilled through the mounting material and into the metal. The wire was then coated with silver paint and inserted into the hole. When the paint dried, the electrical connection was checked with a Fluke model 77/BN multimeter. The wire was secured with a

Cole and Palmer extra fast setting three to five minute epoxy. The completed samples, Figure 16, were then ready to be potentiodynamically polarized to find their pitting potential.

Two methods were used to produce the Aluminum Tantalum (Al-Ta) and Aluminum Tungsten (Al-W) samples used in this project. They were co-sputter deposition of thin film alloys and spray forming. The cold process of co-sputter deposition was used to produce the samples that were used for the heat treatments, and comprised the majority of the research. This was done at The Johns Hopkins University using a Kurt J. Lesker Co. Sputter Coater. This machine produced samples of 8.5 wt% Tantalum in Aluminum and 11 wt% Tungsten in Aluminum on glass slides. These samples were then brought back to the laboratory at the Naval Academy in a dry environment to be cut and heat treated. Each sputter run was cut into eight separate samples using a Buehler Isomet Slow Cut saw and a clean Buehler Diamond blade. In order to avoid any contamination, a new blade was used and devoted only to cutting the sputter deposited samples. A total of eleven sputter runs were done, seven Al-Ta and four Al-W. The spray formed samples were produced at the University of California using an Osprey machine.

Since the spray formed samples were bulk material like the conventional aluminum alloys, they needed to be mounted

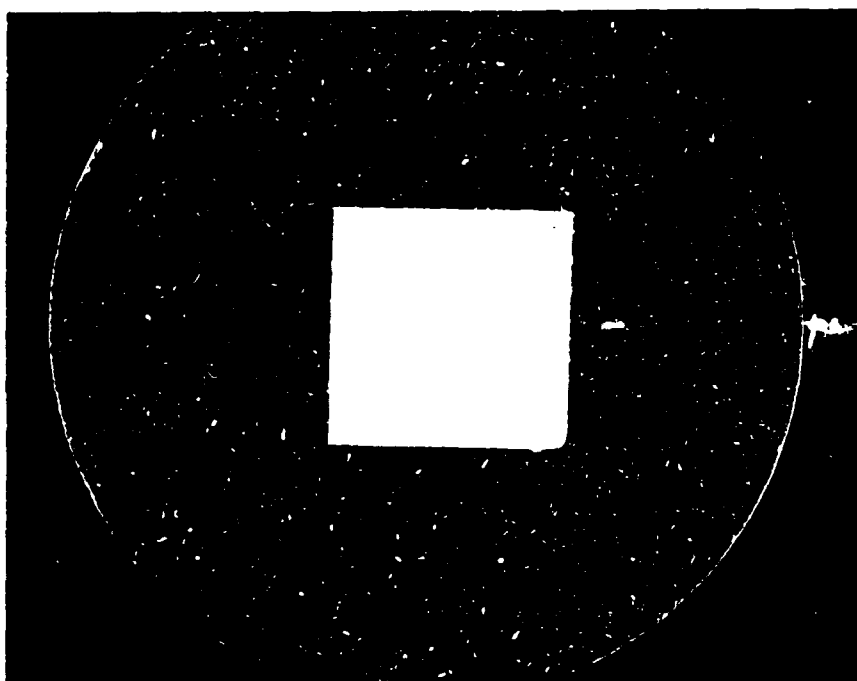

FIGURE 16: *A photo of a completed mount of a conventional aluminum alloy. The sample is 1 cm on each side.*

using a conventional mounting method. However, to avoid further precipitation of the second phase, the spray formed samples could not be mounted using the described process. Instead, the samples were mounted using a cold process. First, the bulk material was cut on a metal saw to get large cylindrical pieces shown in Figure 17. These pieces were then cut into quarters, Figure 18, using a bandsaw. One of the quarters was then trimmed on the isomet slow cut saw with the uncontaminated diamond blade to insure that no steel or other metals were on the specific surface that was to be polished and scanned. A 24 gage wire was then mounted to the sample by drilling a small hole in the material, coating the end of the wire with silver paint, and inserting the wire into the hole. The silver paint was allowed to dry for about an hour, and the resistance of the connection was checked with the Fluke multimeter. Once a low resistance connection was achieved, the wire was fastened to the sample with the three to five minute epoxy. The sample was then mounted using Buehler Sampl-Kwick two part potting material. The potting material consisted of two parts by volume of number 20-3562 Sampl-Kwick Powder with one part number 20-3564 Sampl-Kwick Liquid. The two portions were measured in separate graduated cylinders, and then mixed in a small paper cup. The samples were placed in small molds which were coated with Buehler silicone mold release in order to allow the mount to slip out of the mold.

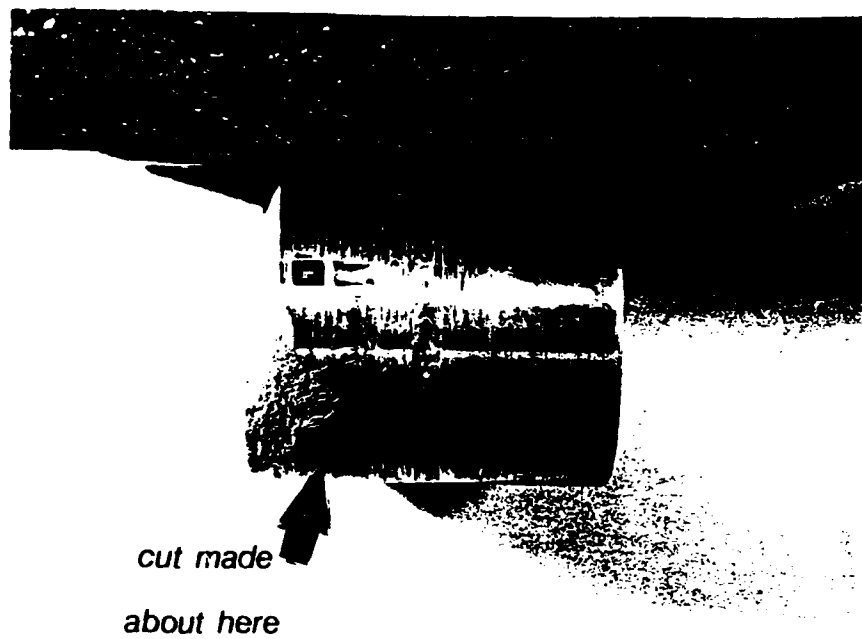

FIGURE 17: *The initial cut was made on the spray formed samples in order to get a small cylinder.*

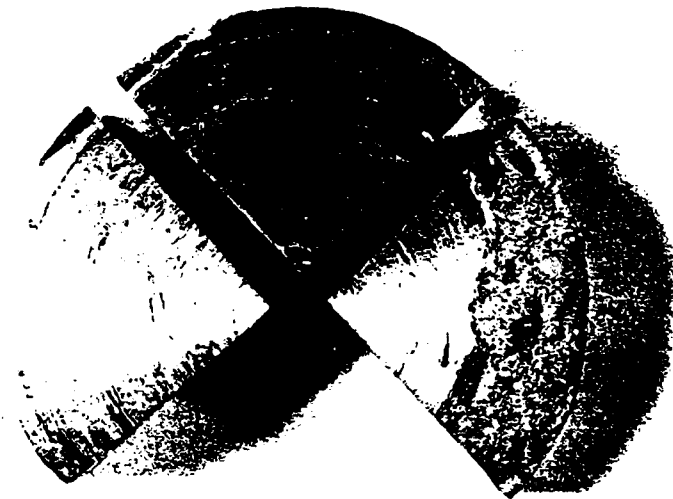

FIGURE 18: *The small cylinder was then cut into quarters.*

The sample has a diameter of 2 in.

The potting material was poured over the sample until the sample was entirely immersed in the liquid. Once the potting material set, about twenty minutes, the mold was removed and the mounting material was allowed to dry for 24 hours. The completed sample, shown in Figure 19, was then polished.

Both the spray formed samples, the three conventional alloys, and the pure aluminum sample were polished to a near mirror finish in order to minimize crevice corrosion. This was done through a two step process. The samples were first polished using a Buehler Handimet Grinder and Buehler Carbimet paper strips of grit 240, 300, 400, 600. The samples were first polished by hand on the 240 grit, being careful to keep the sample flat. Once the entire surface was touched, the sample was rotated 90 degrees and polished on the 300 grit paper. The sample was sanded until all the scratches from the previous polishing paper had left. This process was repeated for the two remaining polishing papers. The sample was then inserted into a Buehler Whirlmet Polisher, and No 40-6351 AB polishing alumina with particle size of 0.5 micron was used to give a near mirror finish.

To potentiodynamically polarize the samples, a cell had to be prepared which would approximate the chloride concentration in the ocean environment. To do this, a 3.5 wt% NaCl solution was made using 14 grams of NaCl and

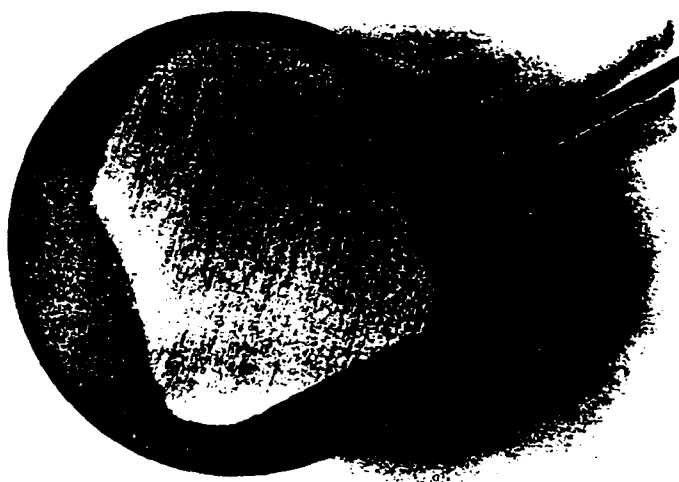

FIGURE 19: *A completed mount of a spray formed sample.*

The entire mount has a diameter of 1 in.

400 ml of distilled water. The NaCl was measured on an Ohaus Dial-O-Gram balance and put into a 500 ml beaker. Then the 400 ml of distilled water were measured using a graduated cylinder and poured into the beaker. The solution was mixed with a glass stirring rod until all the salt was in solution. A carbon rod counter electrode was suspended in the solution along with a Fisher saturated calomel reference electrode. The sample was then suspended in the solution facing the carbon rod. This completed the basic cell arrangement. But, because these alloys corrode at or near their E_{corr} , a few modifications had to be made. First, a tube with a bubbling frit was put into the cell, and the cell was then covered with plastic, Figure 20. The tube was connected to a bottle of nitrogen and the gas was bubbled into the cell at a moderate rate in order to displace the oxygen in the solution. With less oxygen present the rest potential, or E_{corr} , of the alloys would decrease to a lower value and prevent corrosion at the rest potential.

Once the cell was set up, a Model 273A Princeton Applied Research Potentiostat was connected. The sample was attached to the working electrode of the electrometer. The carbon rod was attached to the counter electrode and the reference electrode was plugged into the reference electrode plug. The cell was then given a short period of time to settle at E_{corr} . During this time, the M342C SoftCorr

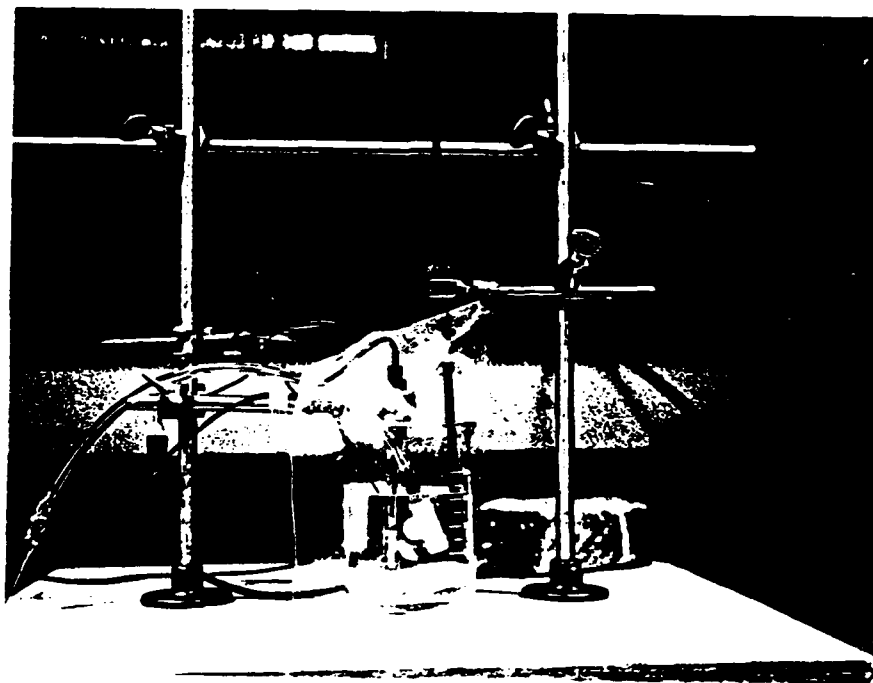

FIGURE 20: *The modified cell used when nitrogen bubbling was necessary.*

Corrosion Software was programmed to potentiodynamically polarize the sample at a rate of 0.2 mV per second. The experiment began at E_{corr} and was stopped once the sample began to pit or once the current density exceeded 50 microamperes per centimeter squared.

The sputter deposited samples were then heat treated in a Thermolyne Type 47900 Furnace at 200°, 300°, and 400° C, and for time intervals of 30, 60, 180, 360, and 720 minutes at each temperature. Since these alloys are reactive to oxygen and various other gases, it was necessary to heat treat the samples in an inert environment of argon gas. To do this, one or two samples were put in a large test tube and sealed with a rubber stopper. Two tubes, one to pump argon into the test tube and one to allow the gases to escape, were inserted into the test tube through the rubber stopper. A thermocouple was also inserted into the test tube through the rubber stopper in order to measure the temperature inside the tube. The test tube arrangement is shown in Figure 21. Argon gas was then vigorously pumped into the test tube for five minutes to displace any oxygen or other gases that may have been present. Since argon is heavier than air, it naturally settled to the bottom of the tube where the sample was and forced the atmospheric air out of the tube. After five minutes, the flow rate of the argon was turned down so that a slight overpressure was maintained in the test tube as to not allow air to seep back in. Once

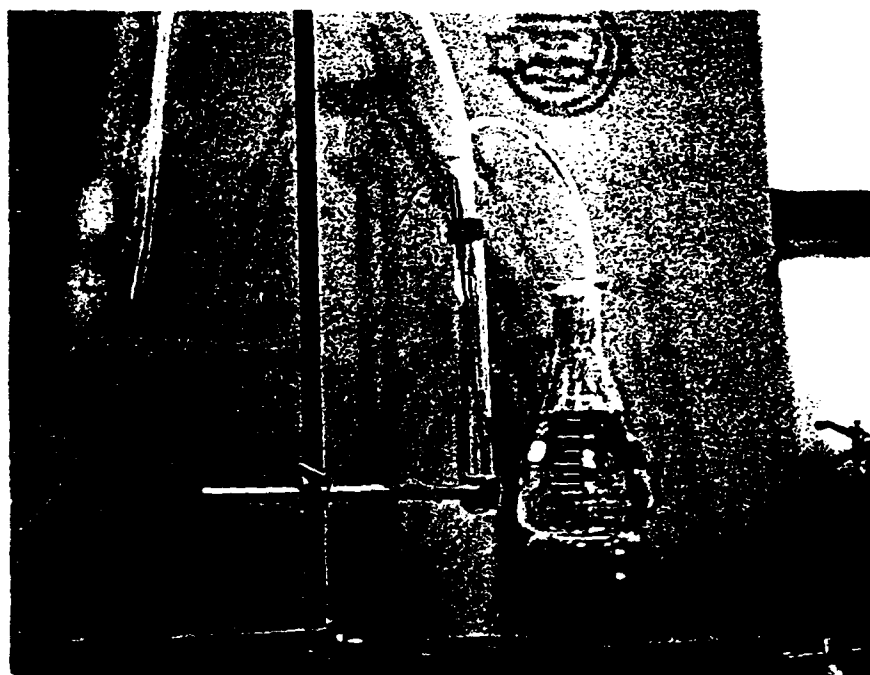

FIGURE 21: *The test tube setup that was used to heat treat the samples. The two gas tubes and the thermocouple can be seen.*

the flow rate was turned down, the sample was ready to be inserted into the furnace. The furnace was brought up to the temperature of the heat treatment and the test tube was inserted into the top of the furnace. The time for the sample to heat up to temperature was recorded. Once the sample achieved the heat treatment temperature, the time of the heat treatment began. At the completion of the heat treatment, the test tube was removed from the furnace and the flow rate of argon was increased in order to speed up the cooling process. The cooling time was also recorded.

Once the heat treatment was complete, the samples were mounted so that they could be potentiodynamically scanned. A wire was attached to the sample and the edges were coated with an epoxy so that the solution would not penetrate between the glass slide and the thin film. The first step was to silver paint a 24 gauge wire to the sample. The silver paint was then allowed to thoroughly dry for about an hour, and the resistance of the connection was measured with the Fluke multimeter. The wire connection was then securely fastened to the slide using a three to five minute epoxy. When this was completed, the resistance was again measured to insure a proper electrical connection. The next step was to coat the edges of the glass slide with Interlux Barrier-Kote Two Part Epoxy Primer, which consisted of a Number 404 Base and a Number 414 Reactor. The West System Two Part Epoxy was initially used to coat the edges of the sample,

but due to difficulty in controlling the epoxy, and a possible crevice corrosion problem, Interlux was used. Polarization curves done on samples with the Interlux had the same characteristics as those generated when the West System was used. Interlux had been shown to resist crevice corrosion in similar experiments conducted at both Johns Hopkins University and Pennsylvania State University. This proved that a crevice corrosion problem did not exist, but due to the ease of application the Interlux was used for the rest of the project. This epoxy was allowed to dry for about 24 hours, and the samples were ready to be scanned.

The sputter deposited samples were potentiodynamically polarized in a cell similar to the one used for the conventional aluminum alloys. It was not necessary, however, to use nitrogen bubbling for these specimens because their pitting potentials were much higher than their rest potentials. Therefore, the bubbling frit and tube were removed from the cell, and no plastic covering was required, Figure 22. The samples were suspended in the solution, and the M342C SoftCorr Corrosion Software was programmed to polarize the samples at 0.2 mV per second.

After the samples were pitted and the scans were finished, a hard copy of the polarization curves was printed out on an Epson FX-85 Dot Matrix Printer. The M342C Corrosion Software was then used to view the data and see

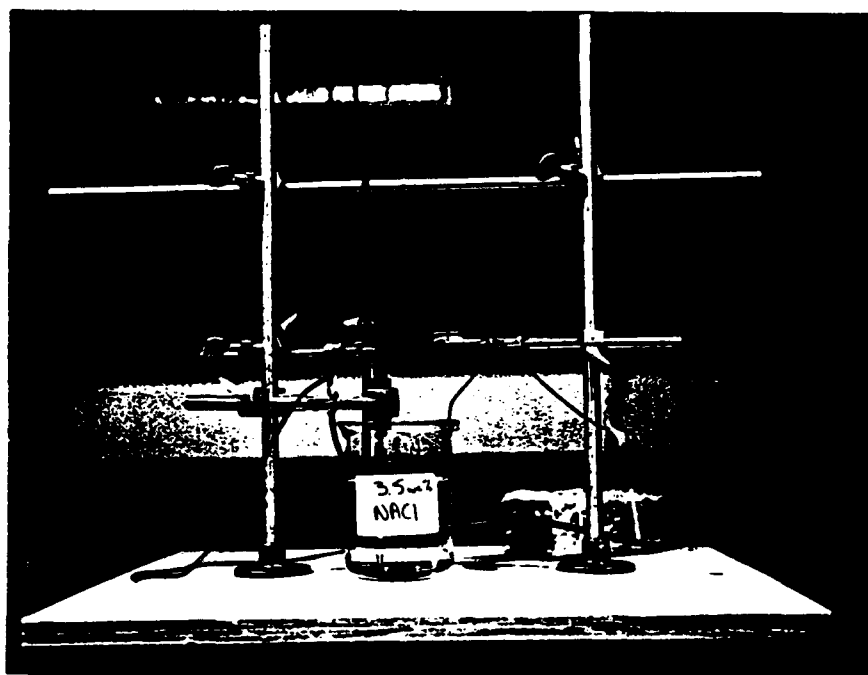

FIGURE 22: *The electrochemical cell setup that was used to potentiodynamically polarize specimens.*

the breakdown potential for each sample. The pitting potential was taken at the point where the current density reached a value of 50 microamperes per centimeter squared. This value was recorded, and then plotted on a pitting potential versus time graph for each temperature.

In an effort to characterize the microstructure of the samples before and after heat treatments, a Jeol JSM-6100 Scanning Electron Microscope was used. The samples were physically and electrically connected to a stage that was placed into the microscope. The electrical connection was made so that the sample would not collect the emitted electrons and become invisible. The chamber was then pumped to a vacuum and the electron beam was initiated. The samples were viewed at a low magnification, 500X, to characterize the overall surface. The magnification was then increased to 10,000X to view any defects, pits, or precipitates that may have been present. The magnification was then increased to 12,000X, and the surface texture of the thin films was examined. Photographs were taken at the different magnifications for both heat treated and unheat treated samples in order to compare the microstructure of the two. The spray formed samples were also characterized in the SEM.

In an attempt to verify the collected data, potentiostatic holds were done on the samples. The set up for these experiments was the same as the potentiodynamic

polarization except for the programming of the software. Instead of increasing the potential at increments of 0.2 mV per second, the potential was held at a constant value. These holds were done for 24 hours each. Both the as received samples and samples that were heat treated at 400° C for three hours were held at -550 mV and the current density was monitored. Additional holds were also done at -700 mV on as processed Al-Ta and Al-W samples. At the termination of the experiment, a hardcopy of the data was made in the form of a current density versus time plot.

RESULTS AND DISCUSSION

Potentiodynamic polarization experiments were done on pure aluminum and some common aluminum alloys in order to establish a baseline pitting potential that could be compared to the pitting potential achieved by the "Stainless Aluminums." Along with 99.999% aluminum (pure aluminum), the three conventional aluminum alloys that were scanned were 6061-T6, 7075-T6, and 2024-T4. They showed pitting potentials of -722 mV for pure aluminum, and -725 mV, -761 mV, and -663 mV, respectively, for the conventional alloys, Figure 23. When galvanically coupled to steel, these alloys would be pulled up to or near their pitting potential

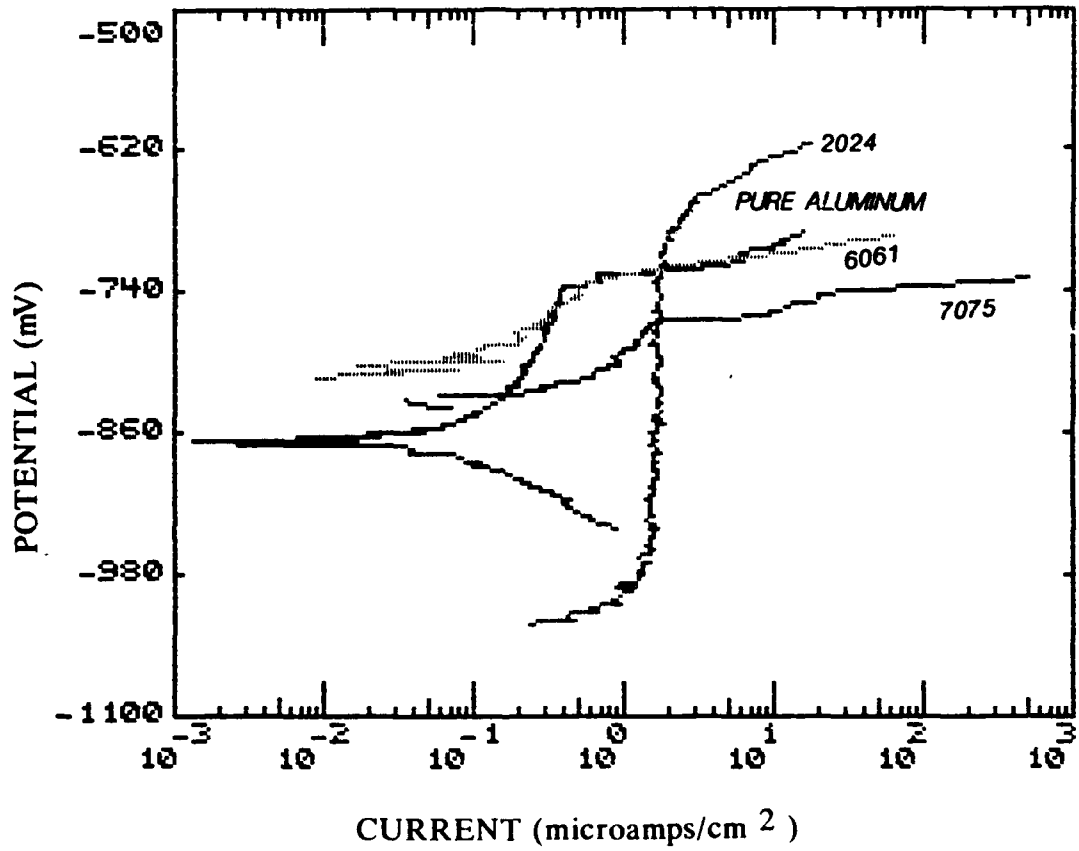

FIGURE 23: Polarization curves of pure aluminum and conventional aluminum alloys.

because steel has a rest potential higher than that of aluminum and aluminum alloys in seawater, Figure 8. This would cause the conventional alloys to experience pitting.

The four spray formed samples were composed of 1 wt% Ta in aluminum (Al-0.51wt% Ta actual), and 1 wt% W in aluminum (Al-0.57wt% W actual) [10]. Two samples of each concentration were produced yielding a total of four bulk samples. It was theorized that the fast solidification rate of the spray forming process would trap the alloy in a super saturated solid solution and exhibit good corrosion properties. The data collected on the alloys was not very encouraging, however. The pitting potentials of the four samples ranged from -686 mV to -721 mV, which is approximately the pitting potential exhibited by pure aluminum. The pitting potential of each specimen is shown in Table 1. The low pitting potentials that were realized by these alloys could be due to two factors. First, the concentration of the alloying element may have been too low. If 5 wt% tungsten or tantalum was used, some of the alloying element could have been trapped in solid solution, which may have yielded improved corrosion properties. Second, if a faster solidification rate could be used, then the alloying element may become trapped in a solid solution.

The co-sputter deposited samples (Al-8wt% Ta and Al-11wt% W) were the main focus of the research. Before any heat treating could be done on the thin films, a pitting

TABLE #1	
Sample Number	Pitting Potential (mV)
241	-714
246	-713
247	-686
249	-721

The pitting potentials of Al-Ta (247 and 249) and

Al-W (241 and 246) in 3.5wt% NaCl solution.

potential for the "as processed" samples had to be determined. For each sputter run, one or more unheat treated samples were potentiodynamically polarized. The Al-Ta samples yielded pitting potentials which ranged from +73 mV to -293 mV between the different sputter runs, Table 2. The Al-W samples yielded pitting potentials which ranged from -147 mV to -236 mV for varying sputter runs, Table 3. These are very large improvements over the pitting potential of pure aluminum (-722 mV), and are consistent with previous work on these alloys. This tremendous improvement showed that "Stainless Aluminums" were definitely produced, and that the alloys were in a supersaturated solid solution.

Once the baseline pitting potential was determined, the heat treatments were done. The first set of heat treatments was done on the Al-Ta samples at temperatures of 200°, 300°, and 400° C for varying amounts of time. The data is shown in Tables 4-6 and is plotted on a pitting potential versus time graph, Figures 24 through 26. The Al-W samples were then heat treated at 200°, 300°, and 400° C for varying amounts of time. This data is shown in Tables 7, 8, and 9 and is plotted in Figures 24 through 26. In each case, the curves show that the alloys experience a sharp decrease in pitting potential initially, and then continued to decrease slightly with increasing time. The data also shows that as the temperature increased, the pitting potential fell off to lower values. This is consistent with the limited data

TABLE #2	
Sputter Run	Pitting Potential (mV)
1	-247
1	73
1	-272
2	-192
2	-209
2	-89
3	7
3	90
4	-293
4	-290
5	-198
5	-218
6	-150
7	-213

The "As-Processed" pitting potential for each Al-Ta sputtering run.

TABLE #3	
Sputter Run	Pitting Potential (mV)
1	-149
1	-147
2	-218
3	-236
4	-174

The "As-Processed" pitting potential for each Al-W sputtering run.

TABLE #4	
Time (min)	Pitting Potential (mV)
5	-71
15	-45
30	-62
60	-265
180	-139
360	-162
720	-173

Pitting potentials of sputter-deposited Al-Ta samples heat treated at 200 C for varying amounts of time.

TABLE #5	
Time (min)	Pitting Potential (mV)
15	-45
30	-98
45	5
60	-307
180	-482
360	-254
720	-322

Pitting potentials of sputter-deposited Al-Ta samples heat treated at 300 C for varying amounts of time.

TABLE #6	
Time (min)	Pitting Potential (mv)
15	-438
30	-470
45	-435
60	-478
180	-465
360	-446
720	-439

Pitting potentials of sputter-deposited Al-Ta samples heat treated at 400 C for varying amounts of time.

HEAT TREATMENTS AT 200 C Al-Ta and Al-W

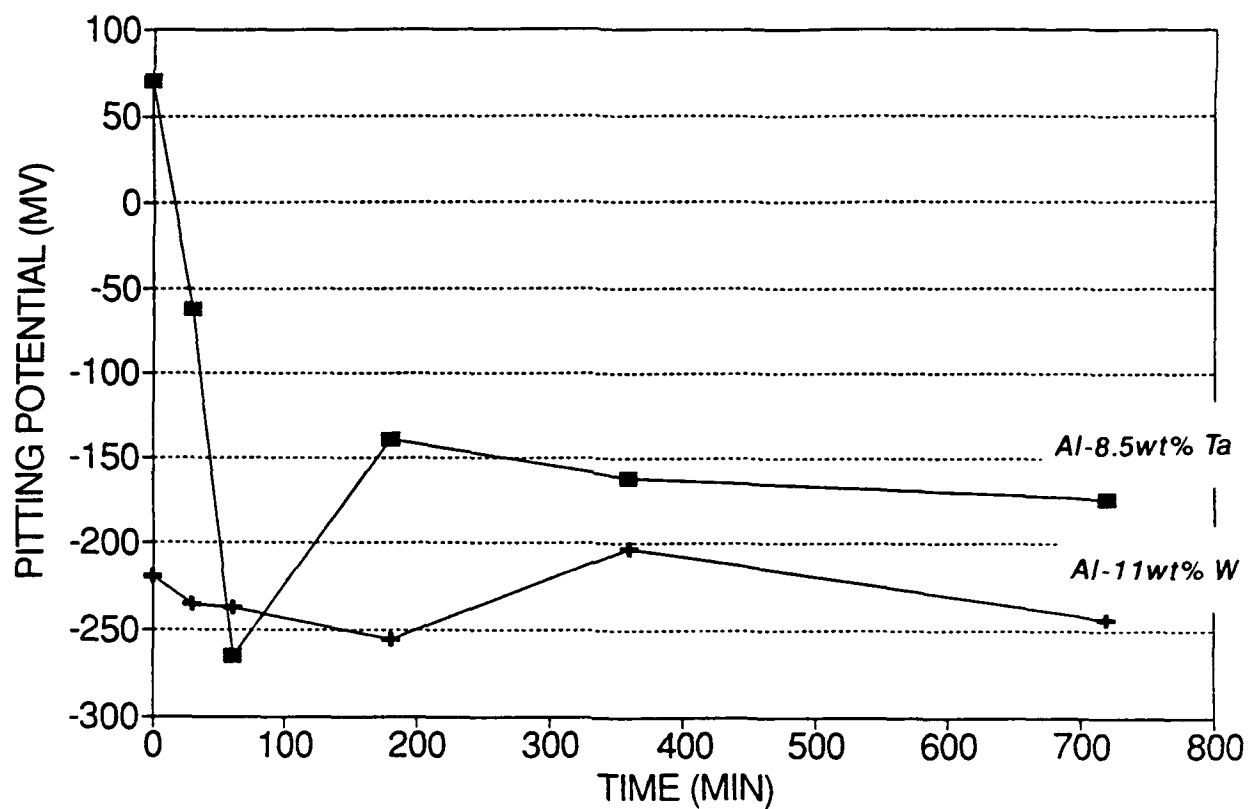

FIGURE 24: *Plot of pitting potential vs. time for Al-Ta and Al-w samples heat treated at 200 C.*

HEAT TREATMENTS AT 300 C Al-Ta and Al-W

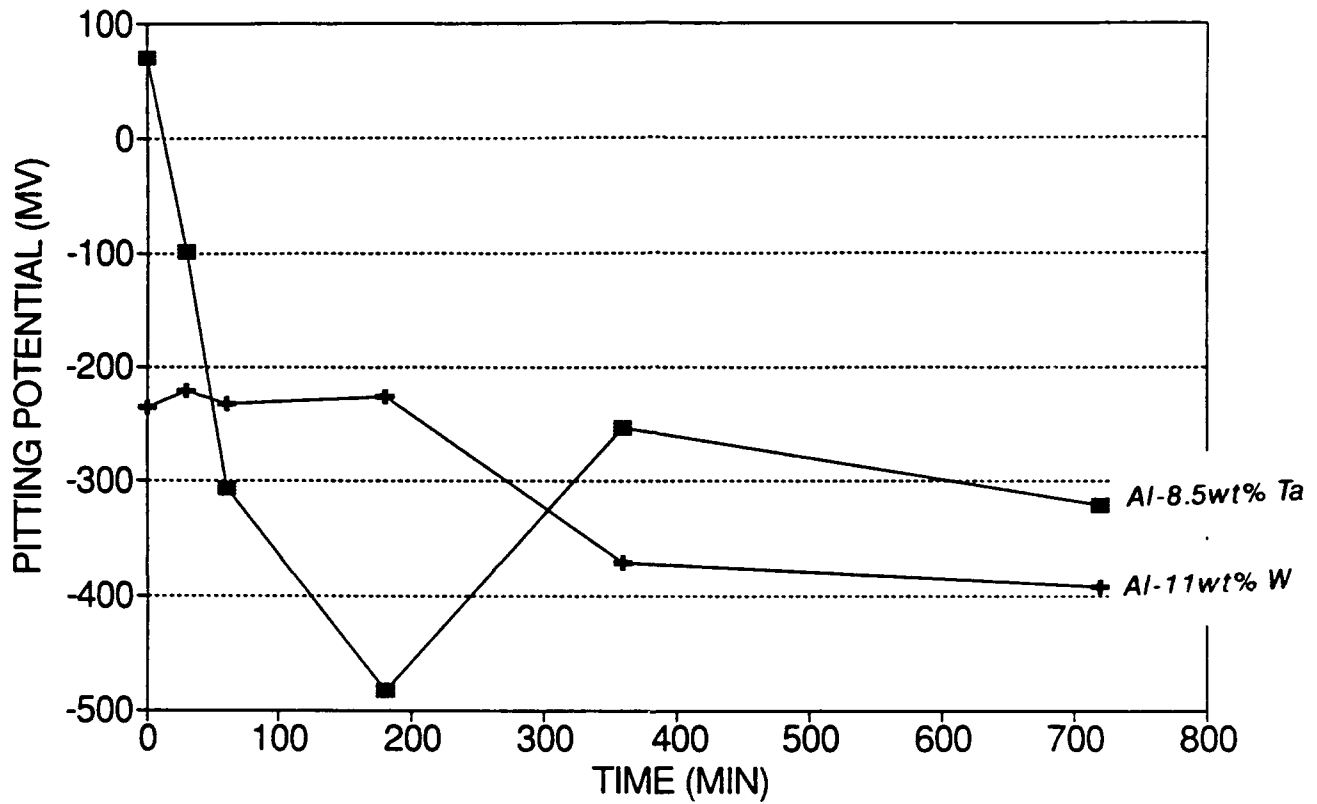

FIGURE 25: Plot of pitting potential vs. time for Al-Ta and Al-w

samples heat treated at 300 C.

HEAT TREATMENTS AT 400 C Al-Ta and Al-W

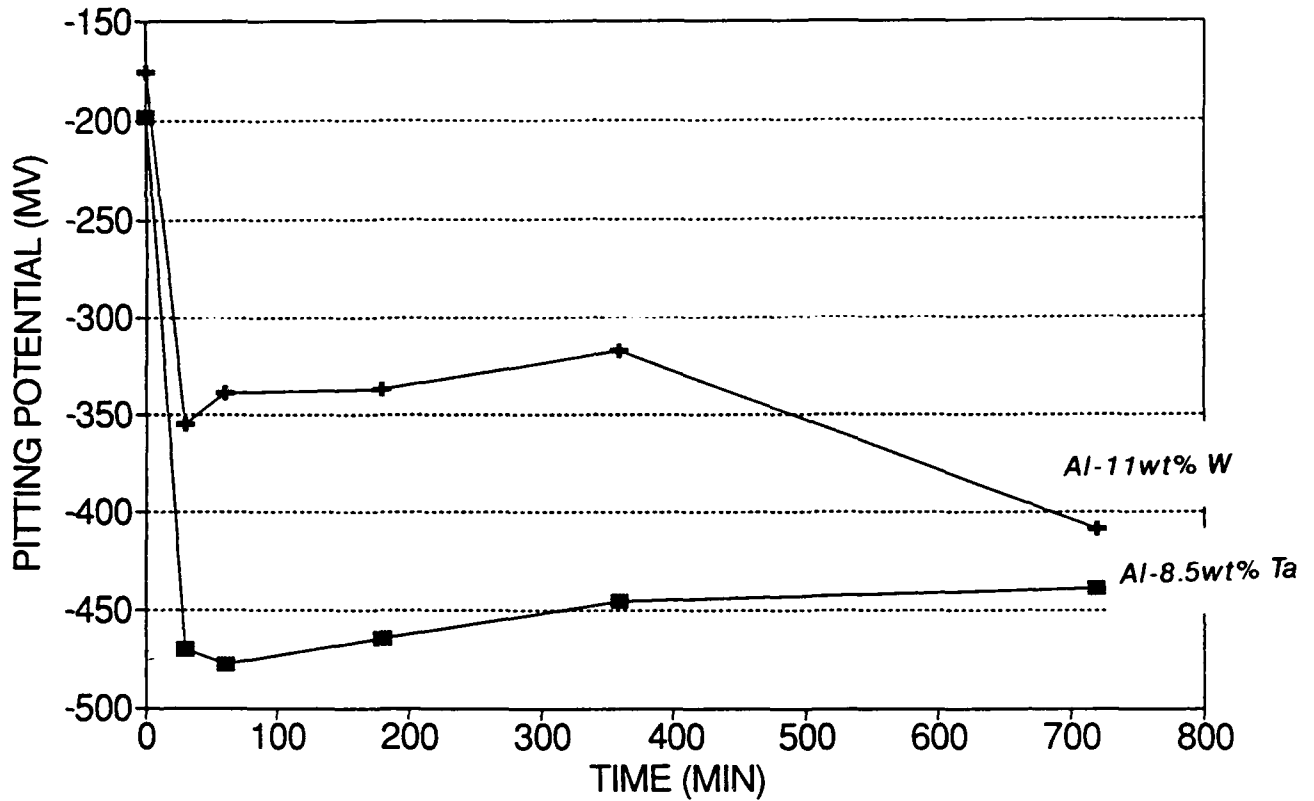

FIGURE 26: Plot of pitting potential vs. time for Al-Ta and Al-w

samples heat treated at 400 C.

TABLE #7	
Time (min)	Pitting Potential (mV)
30	-235
60	-237
180	-255
360	-203
720	-245

Pitting potentials of sputter-deposited Al-W samples heat treated at 200 C for varying amounts of time.

TABLE #8	
Time (min)	Pitting Potential (mV)
30	-220
60	-232
180	-226
360	-371
720	-392

Pitting potentials of sputter-deposited Al-W samples heat treated at 300 C for varying amounts of time.

TABLE #9	
Time (min)	Pitting Potential (mV)
45	-355
60	-354
180	-337
360	-317
720	-409

Pitting potentials of sputter-deposited Al-W samples heat treated at 400 C for varying amounts of time.

presented by Martin Marietta Laboratories. Their heat treatments for one hour at 400° C and 12 hours at 400°C both showed decreases in pitting potential, but not a total loss of the improved corrosion properties.

The polarization curves that were generated during this study did not share the same characteristics as the polarization curves presented in the literature. Initially, it was theorized that a crevice corrosion problem existed. However, the use of the Interlux epoxy disproved that theory. The other possible explanation was the aggressive solution that was used. In the literature, a 0.1 M KCl solution has been used when polarization experiments were done [2,3,4,5]. The solution that was used in this study was 3.5 wt% NaCl in distilled water, which was used to approximate the ocean environment. This equates to a 0.599 M NaCl solution, or about six times more chloride concentration than the solution in the literature. This large increase in chloride could be the reason why the baseline pitting potentials of the as received samples were lower than the literature, and why the polarization curves did not exhibit the same characteristics. The curves showed a good passive region and breakdown when the samples were not heat treated, or heat treated for short periods of time. However, when the samples were held at elevated temperatures for extended periods of time, the polarization curves did not show a passive region with a definite breakdown, or

pitting potential. They did, however, show better corrosion resistance than the conventional aluminum alloys. For these materials, a value of 50 was used to determine the pitting potential. This value for the current was chosen because it is no longer small enough to be deemed a passive current.

From this data some estimates could be made about how the "Stainless Aluminums" would react to other processes that involve elevated temperatures. One such process is welding. From the collected data it could be estimated that the corrosion properties of the welded area, and the region surrounding the weld would probably experience some degradation in its corrosion properties. High service temperature could also cause the corrosion properties of these alloys to decrease. This would depend on the actual temperature that the alloy was being exposed to, but elevated service temperature would essentially be a prolonged heat treatment.

Potentiostatic holds were done on several heat treated and unheat treated samples in order to determine if the potentiodynamic polarization data was in fact valid and not being masked by a long induction time for pitting. The holds were done at potentials of -550 mV and -700 mV on both "as processed" samples and samples heat treated at 400° C for three hours. Both Al-Ta and Al-W were used for the twenty-four hour holds. The data that were compiled were both confusing and disturbing. Four samples, one as

received Al-W, one as received Al-Ta, one Al-W heat treated at 400° C for three hours, and one Al-Ta heat treated at 400° C for three hours were held at a static potential of -550 mV. All four of the samples showed anodic currents (corrosion) within the first five hours. The two heat treated samples showed anodic currents for much longer periods of time, Figure 27 and Figure 28, and the films were completely removed from the glass slide after the 24 hour period. The two as processed samples showed sharp increases in anodic currents initially, but then fell back to little or no current, Figure 29 and Figure 30. The Al-Ta film was removed from the glass slide again, but the Al-W remained intact. Since the holds at -550 mV were not successful, additional holds were done at -700 mV for only "as processed" samples. Again four samples were scanned, two Al-Ta and two Al-W. The Al-W samples showed no anodic currents and the films held up during the scans, Figure 31 and Figure 32. The Al-Ta, however, did not do so well during the scans. Both samples showed some anodic currents, with one of the samples corroding over most of the scan and removing half the film, Figure 33 and Figure 34. Research done at The Johns Hopkins University has shown that some mechanical breakdown occurs on these thin sputter deposited films when they are immersed for long periods of time. This breakdown has been observed in chloride environments and also in chloride free environments. This

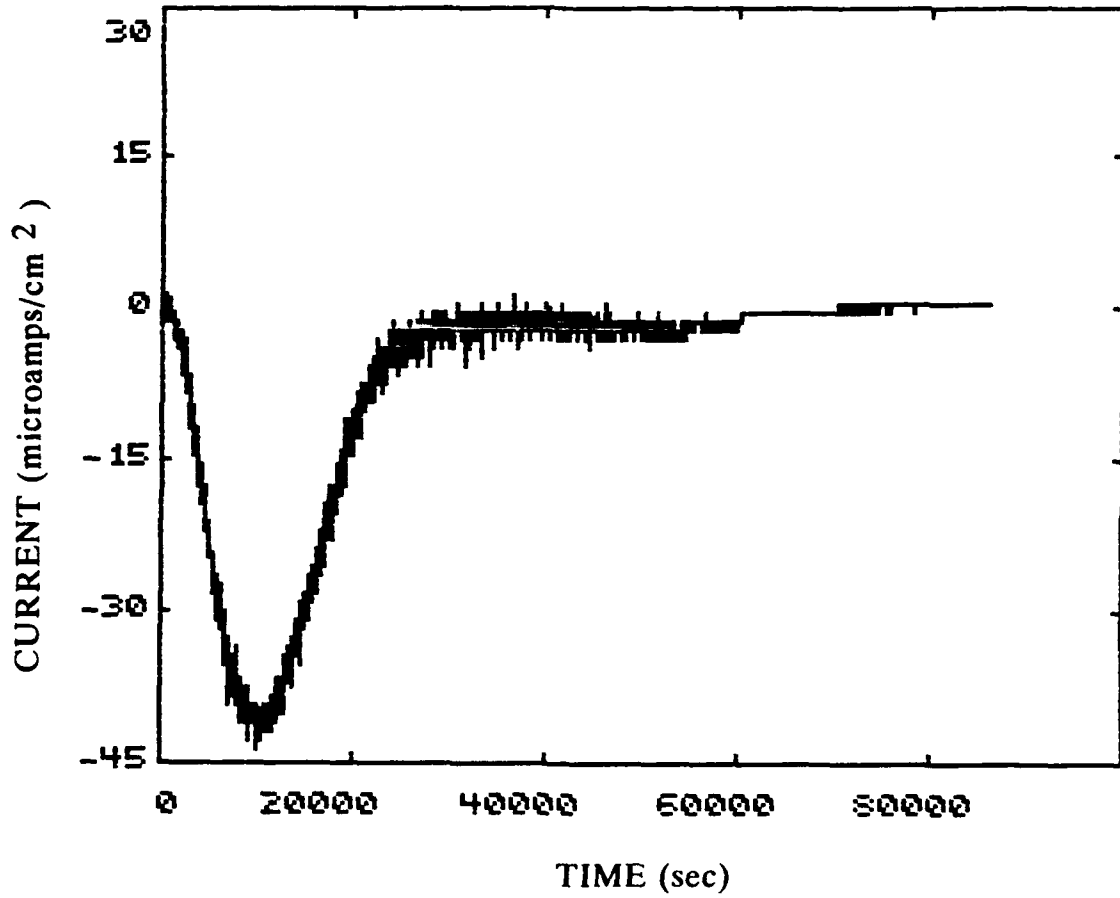

FIGURE 27: *A potentiostatic hold done on a an Al-W sample heat treated at 400 C for three hours.*

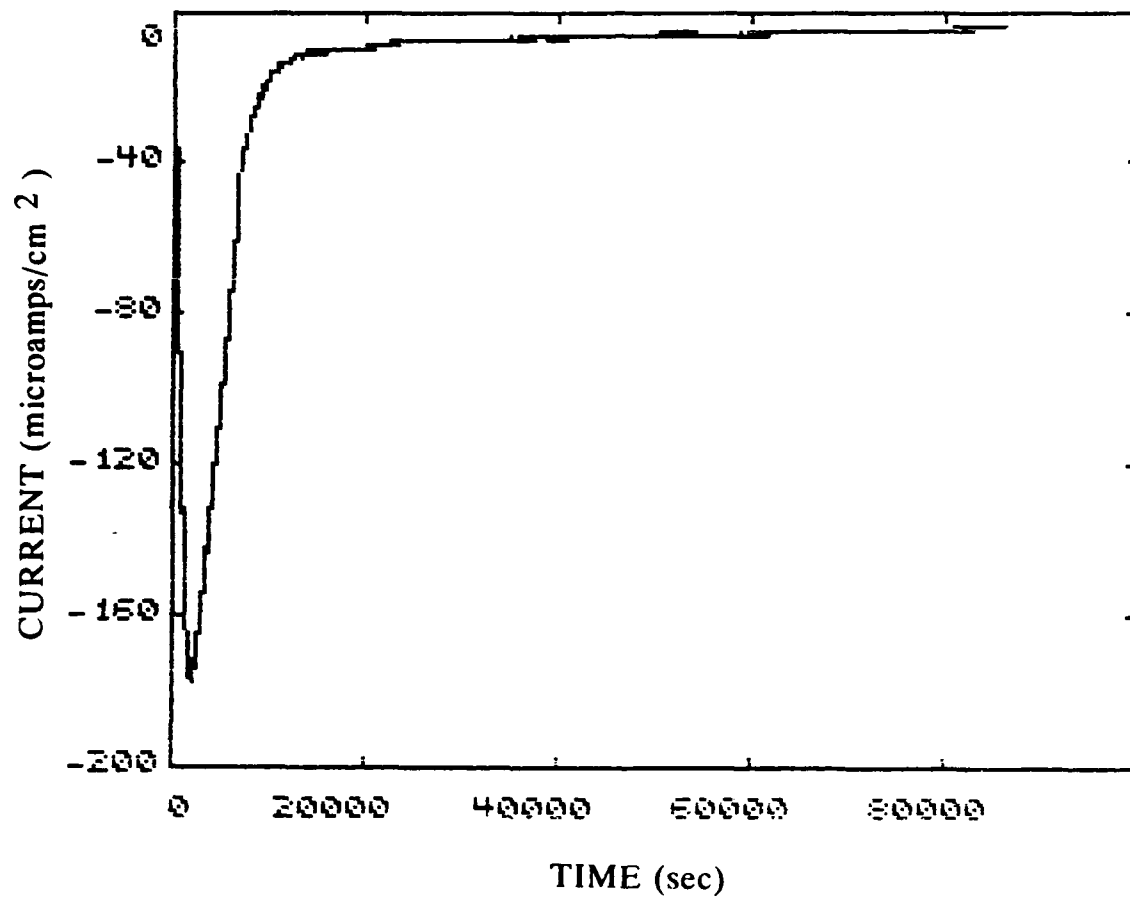

FIGURE 28: *A potentiostatic hold done on an Al-Ta sample heat treated at 400 C for three hours.*

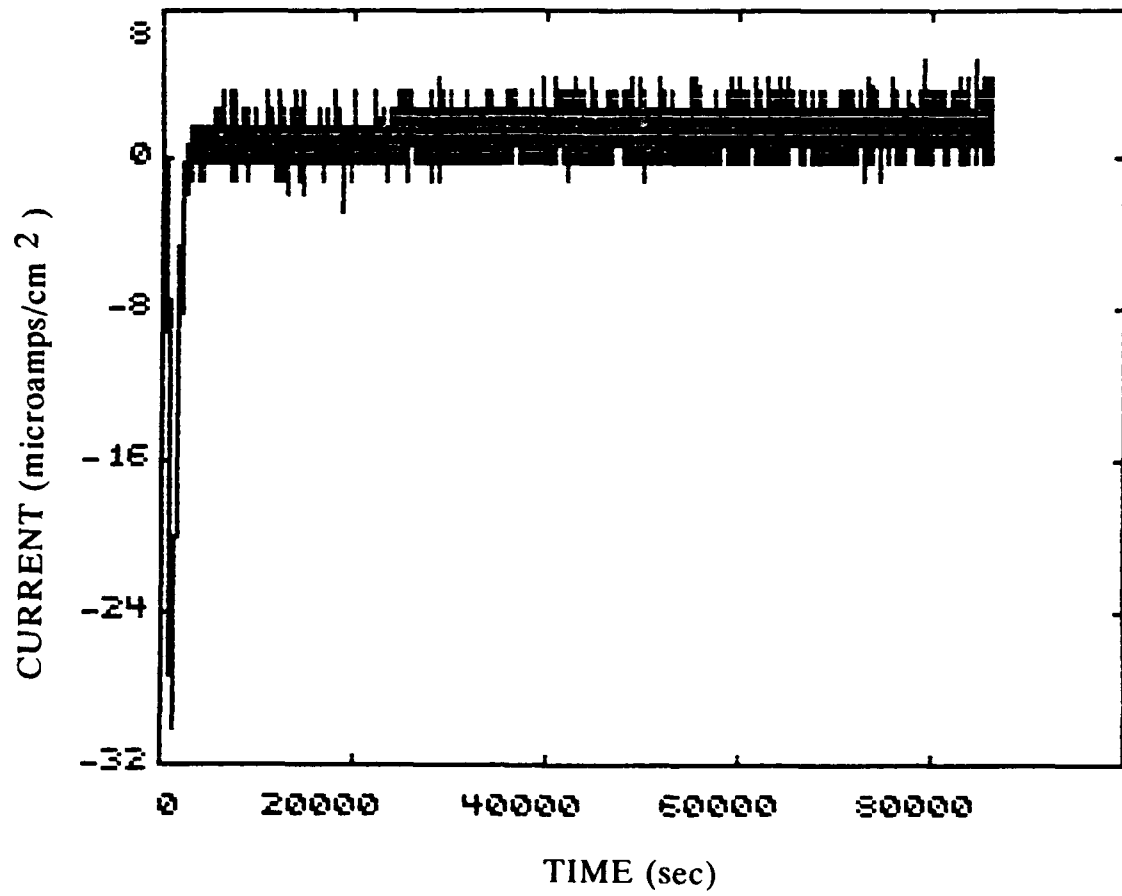

FIGURE 29: *A potentiostatic hold done on an unheat treated*

Al-W sample.

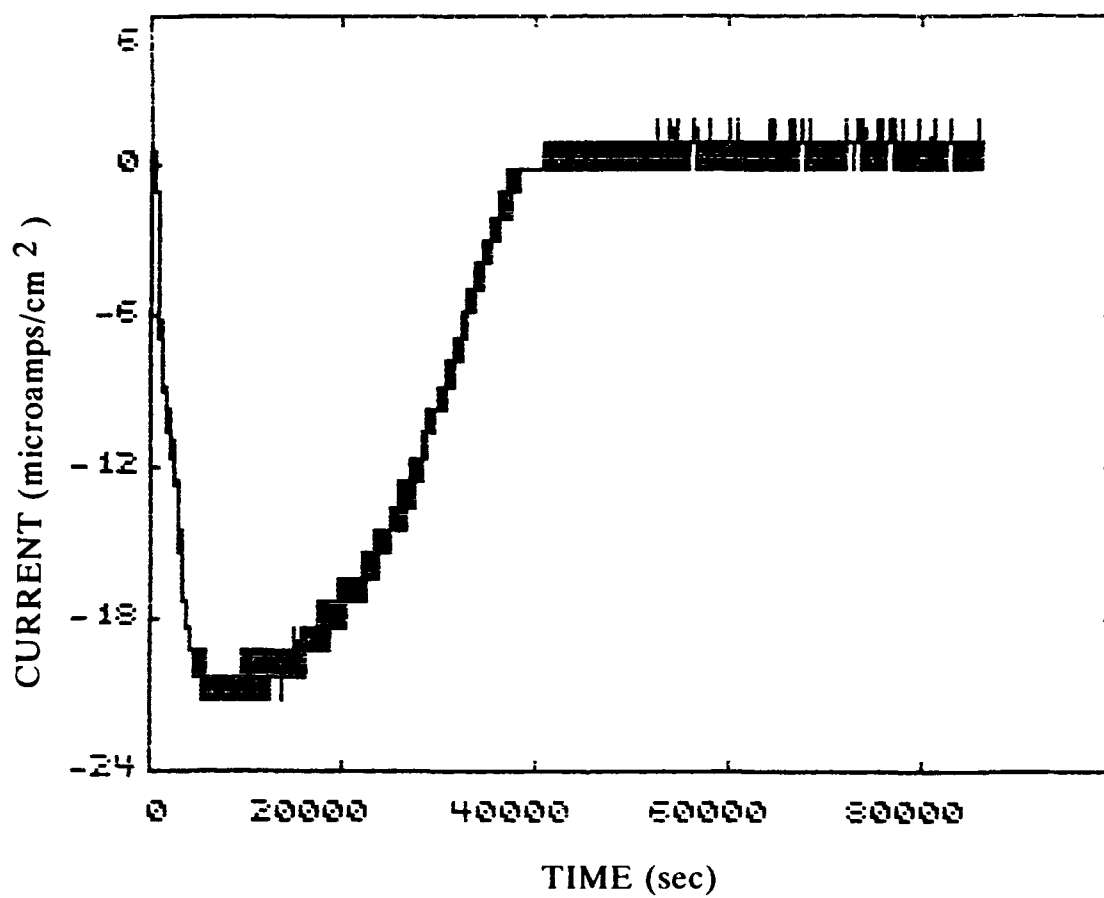

FIGURE 30: A potentiostatic hold done on an unheat treated Al-Ta sample.

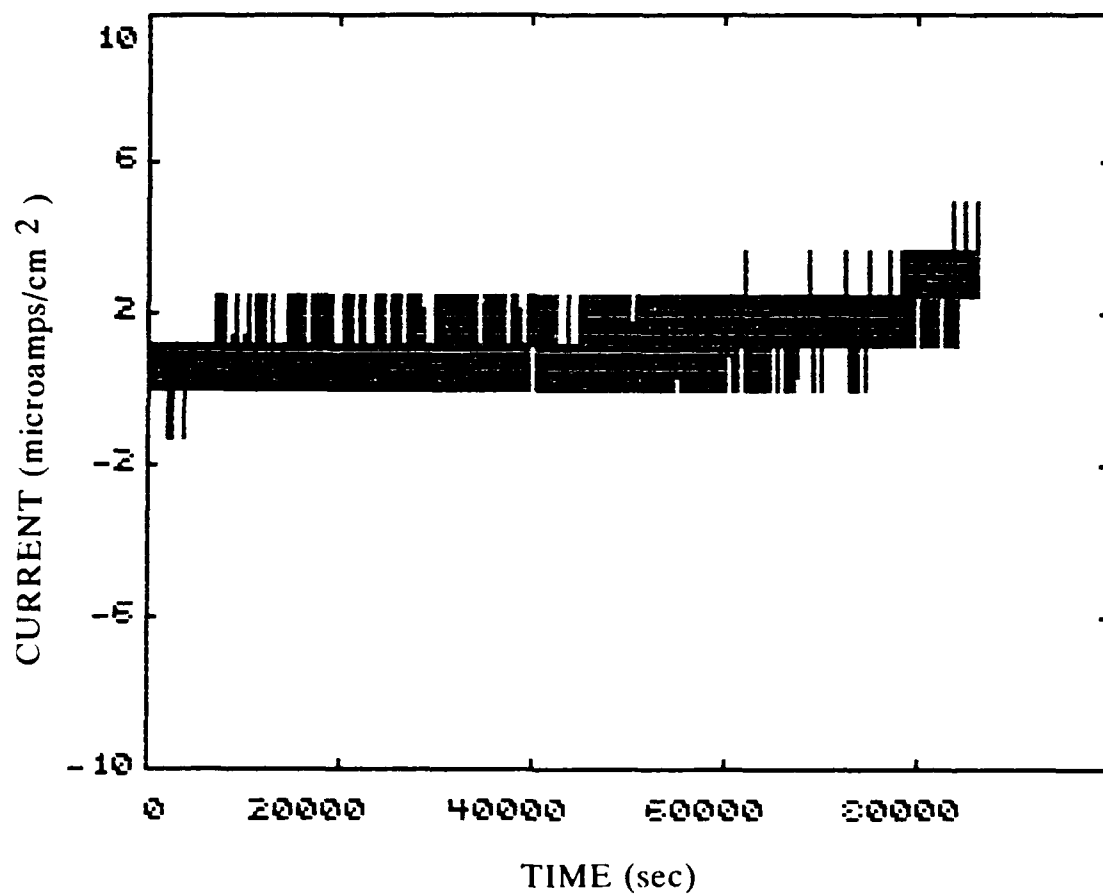

FIGURE 31: A potentiostatic hold done on an unheat treated Al-W sample in 3.5wt% NaCl solution.

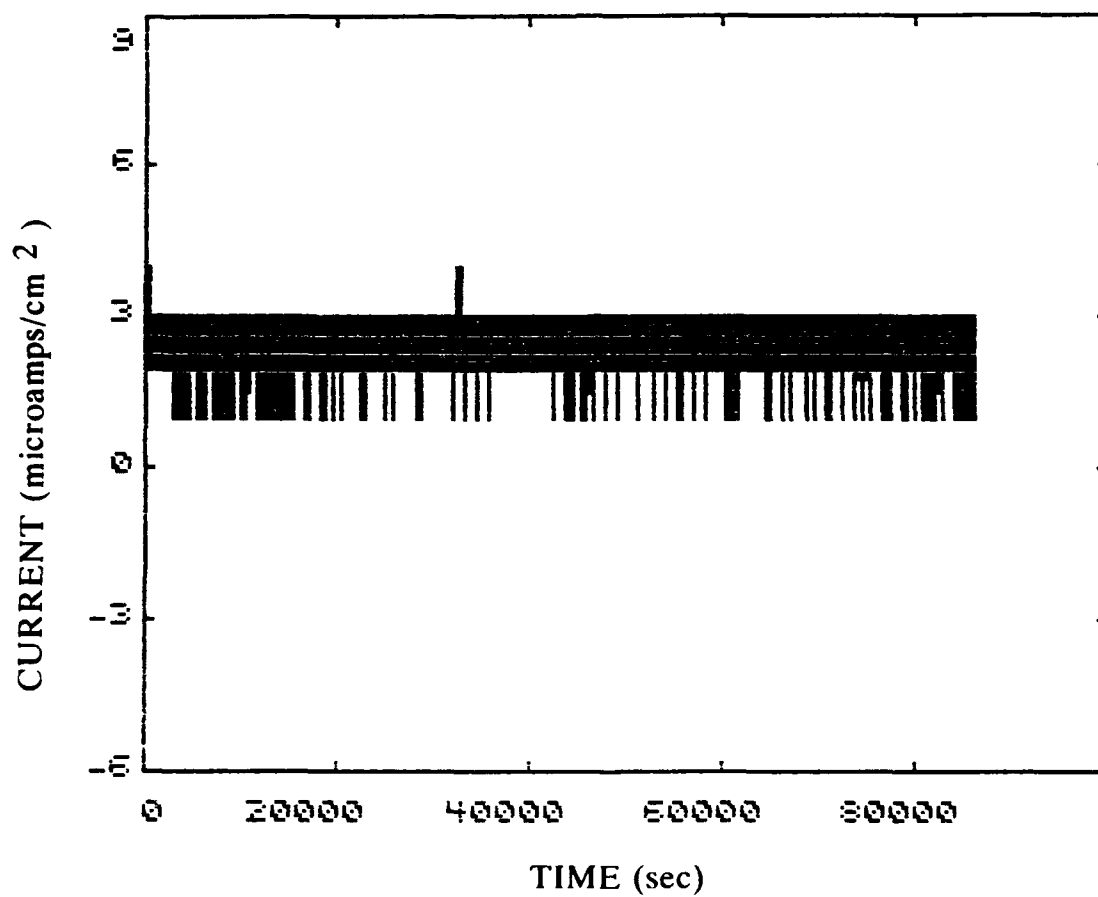

FIGURE 32: *A potentiostatic hold done on an unheat treated Al-W sample in 3.5wt% NaCl solution.*

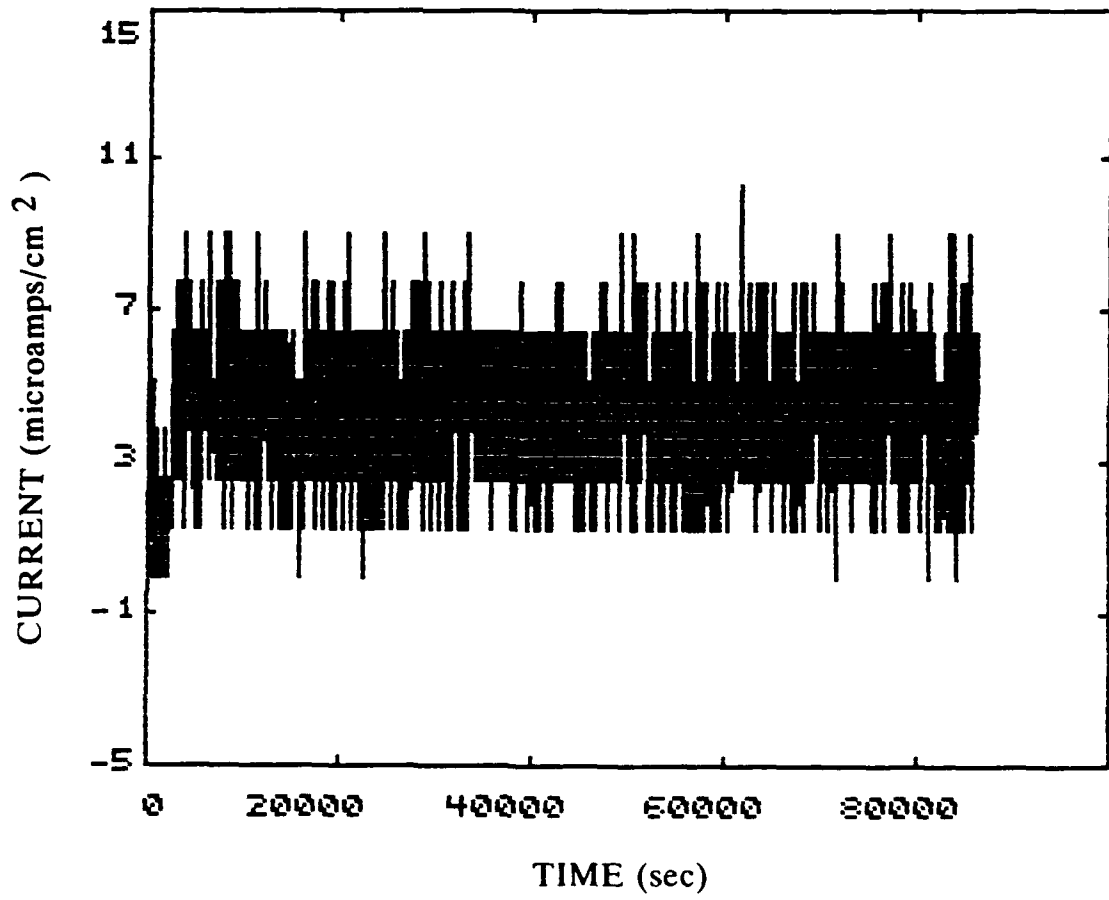

FIGURE 33: *A potentiostatic hold done on an unheat treated Al-Ta*

sample in 3.5wt% NaCl solution.

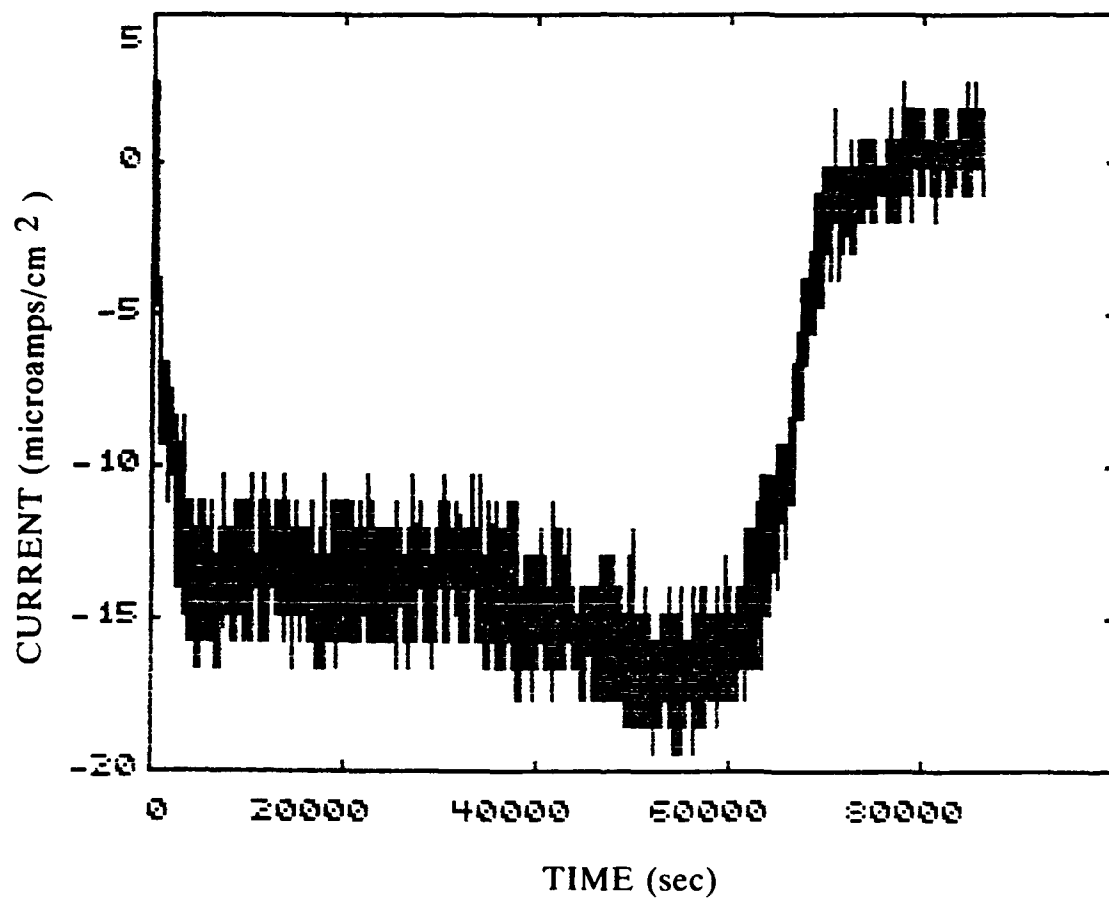

FIGURE 34: A potentiostatic hold done on an unheat treated Al-Ta sample in 3.5wt% NaCl solution.

mechanical damage could be causing crevices to develop and thus initiate crevice corrosion. This would give a false indication of the resistance to pitting. Although these potentiostatic holds have caused some concern, the tests are not conclusive at this stage.

Scanning electron microscopy was done on both the "as processed" samples and the heat treated samples in order to characterize the microstructure. First, Al-Ta and Al-W "as processed" films were viewed in the microscope. The surface was shown to be uniform, and generally free from any precipitates. Next, Al-Ta and Al-W films that were heat treated at 200°, 300°, and 400° C for one hour, and a sample that was heat treated at 400° C for 12 hours were examined in the microscope to view the effects of elevated temperature on the films. It was shown that with increasing temperature, precipitates larger in size (from one micron to 10 microns), and more numerous, developed (Figures 35 and 36). It was also noted that with increased time and temperature, some of the precipitates tended to form into long lines, Figures 37 and 38. When samples that had been pitted were viewed in the microscope, it was noted that pitting almost always occurred at precipitates, and that the aluminum surrounding the precipitate was corroded away, Figure 39 and 40. However, pitting was not initiated at every precipitate on the film, and seemed to occur more often at larger precipitates.



FIGURE 35: SEM photo of an Al-W sample
heat treated at 200 C for one hour.



FIGURE 36: SEM photo of an Al-W sample
heat treated at 400 C for one hour.

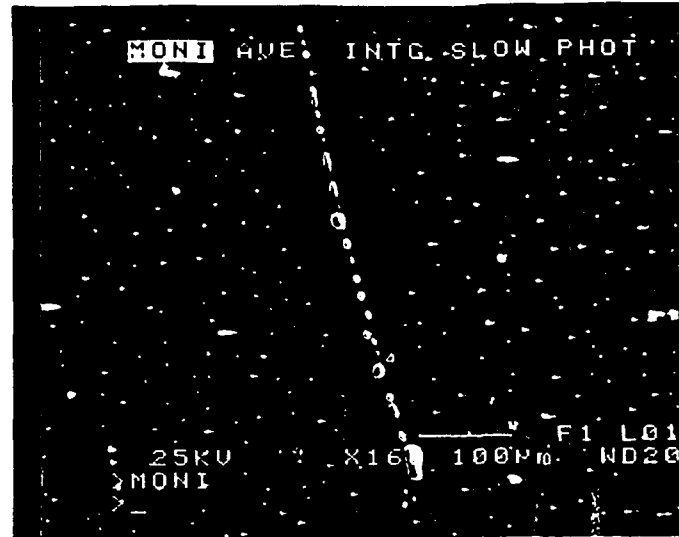

FIGURE 37: SEM photo of an Al-W sample
heat treated at 400 C for twelve hours.

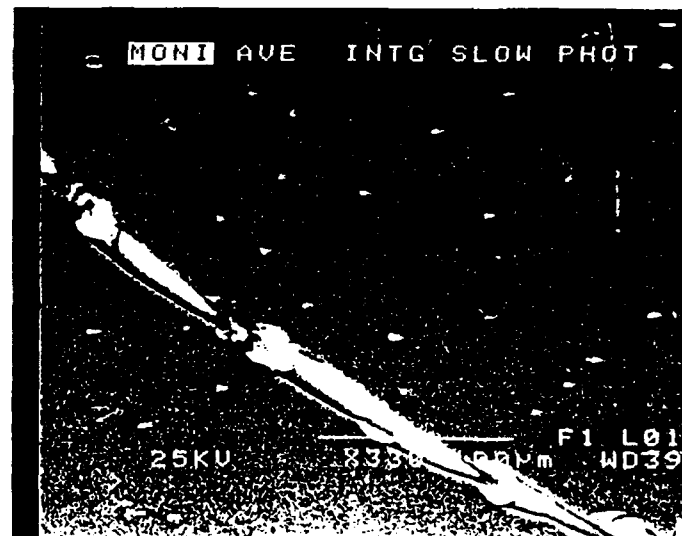

FIGURE 38: SEM photo of an Al-Ta sample
heat treated at 400 C for one hour.



FIGURE 39: SEM photo of a pitted region on a thin film. The brightness is caused by charging on the glass slide.

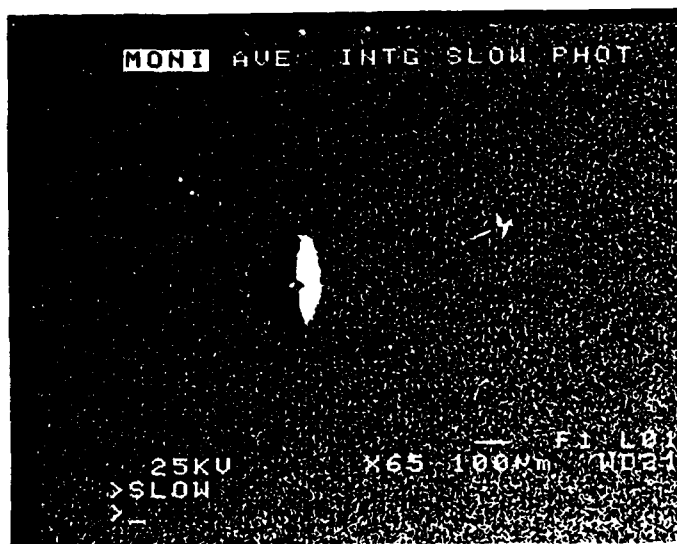

FIGURE 40: The same pitted region, however the precipitate can be seen in the center of the pit.

The spray formed samples were also characterized in the scanning electron microscope before and after polarization. Before polarization, large precipitates of approximately one to five microns could be seen in the material. After polarization and the initiation of pitting, it was noted that the attack occurred in the region around the precipitates, Figures 41 and 42.

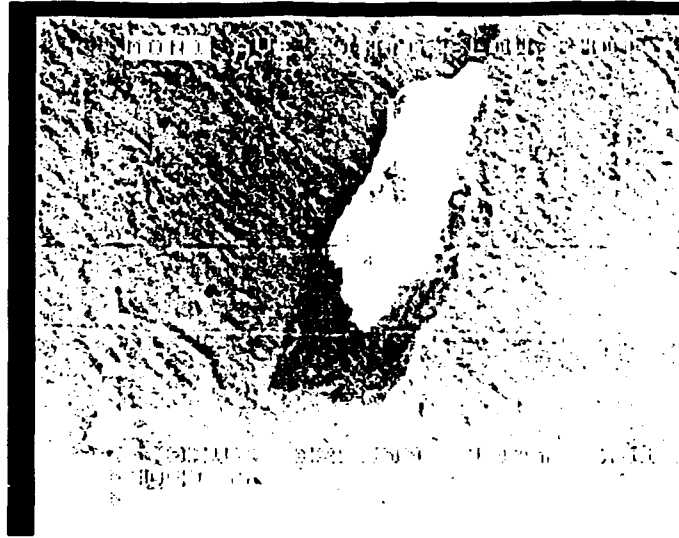

FIGURE 41: SEM photo of a precipitate on the surface of the spray formed sample. The photo was taken after the initiation of pitting.

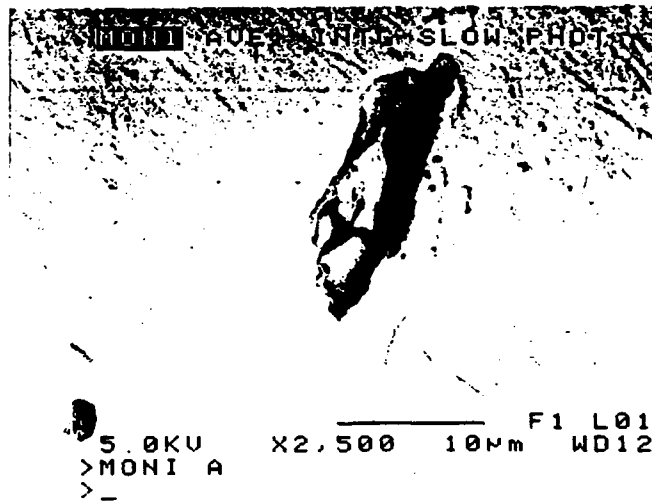

FIGURE 42: The inverse of the same image clearly shows the precipitate in the center of a corroded region.

CONCLUSIONS

Based upon the data collected and microstructure characterization presented above, the following conclusions can be drawn:

1. Conventional aluminum alloys show very little, if any, increase in their pitting potential over pure aluminum.
2. Spray forming, a rapid solidification process, did not trap the tungsten or tantalum in a supersaturated solid solution.
3. Neither the spray formed Al-1.0wt% Ta nor the spray formed Al-1.0wt% W showed any improvement in pitting potential over pure aluminum.
4. Pitting attack appeared to be concentrated around the large precipitates in the two spray formed materials.
5. The "as processed" Al-8wt% Ta and Al-11wt% W demonstrated large increases, as much as 790 mV, in pitting potential as compared to pure aluminum or conventional aluminum alloys.
6. Heat treatments caused the pitting potential to decrease for both sputter deposited materials. Increasing the temperature caused a relatively larger decrease in pitting potential, as well as increasing the amount of time of the heat treatment. Elevated temperature did not totally destroy the corrosion

properties of the material, however, and even after 12 hours, the pitting potential was not reduced to that of pure aluminum.

7. Scanning electron microscopy showed that the "as processed" sputtered specimens were generally free of precipitates and were composed of a uniform surface with some surface texture. Once the samples were subject to heat treatments at 200° C for even 30 minutes, precipitate growth was noted.
8. For increased temperature, the precipitates became more abundant, and increased in size. Likewise, with increasing amounts of time, the precipitates were more numerous and larger.
9. After pitting was initiated, the attack was observed to be around the precipitates in the material. However, attack was not observed around every precipitate.
10. Potentiostatic holds for 24 hours at -550 mV showed anodic currents, or corrosion, for both the samples that were heat treated at 400° C for three hours and the unheat treated Al-Ta and Al-W samples. Both of the Al-Ta films, heat treated and unheat treated were completely removed from the substrate. The Al-W samples showed some pitting, but remained intact. Holds done at -700 mV on unheat treated samples, two of each alloy, showed similar results. Experiments done at The Johns Hopkins University have

shown some mechanical damage to these alloys during potentiostatic experiments, and could be the cause of the pitting. However, these experiments are inconclusive at this time.

ACKNOWLEDGEMENTS

I would like to gratefully acknowledge Professor Patrick J. Moran for his continual guidance and help during this project. I would like to thank R. Scott Lillard and Christopher Streinz for their help in the production of the sputter deposited samples, and their continual advice throughout the project. I would also like to thank laboratory technicians, John Hien, Robert Woody, and Louise Bechnel for their help in the mechanics of the project. Furthermore, I would like to acknowledge Professor Joseph F. Lomax and the Chemistry department for help in doing the initial heat treatments on the sputter deposited samples. I would also like to thank Dr. Angela Moran at the David Taylor Research Center for supplying the spray formed samples.

REFERENCES

1. Callister, W.D., "Materials Science and Engineering." John Wiley and Sons, Inc. New York, New York. 1991.
2. Cote, G.O., Davis, G.D., Fritz, T.L., Moshier, W.C., "Evolution of the Chemistry of Passive Films of Sputtered-Deposited, Supersaturated Al Alloys." Martin Marietta Laboratories Technical Report 89-12c, January 1989.
3. Davis, G.D., Fritz, T.L., Moshier, W.C., Rees, B.J., Shaw, B.A., "A Study of the Influence of Alloying Additions on the Passivity of Aluminum." Martin Marietta Laboratories Technical Report 91-10c, March 1, 1991.
4. Davis, G.D., Fritz, T.L., Shaw, B.A., "A Study of the Influence of Alloying Additions on the Passivity of Aluminum." Martin Marietta Laboratories Technical Report 90-28c, February 1990.
5. Davis, G.D., Fritz, T.L., Moshier, W.C., Rees, B.J., Shaw, B.A., "The Influence of Tungsten Alloying Additions on the Passivity of Aluminum." 1991-1992.
6. Hubler, G.K., Kant, R.A., McCafferty, E., Moore, P.G., Natishan, P.M., Sartwell, B.D., "Naval Research Laboratory Surface Modification Program: Ion Beam and Laser Processing of Metal Surfaces for Improved Corrosion Resistance." Naval Research Laboratory, May 5, 1986.
7. Hubler, G.K., McCafferty, E., Natishan, P.M., "Surface Charge Considerations in the Pitting of Ion-Implanted Aluminum." Naval Research Laboratory, February, 1988.
8. Janik-Czachor, M., Thompson, G.E., Wood, G.C., "Assessment of the Process Leading to Pit Nucleation."
9. Kruger, J., "Passivity of Metals - A Materials Science Perspective." The Institute of Metals and ASM International, 1988.
10. Lavernia, E.J., "Spray Atomization and Deposition: Ceramic Particle Injection and Experiments With Al-Ta, And Al-W." Materials Science and Engineering Department of Mechanical and Aerospace Engineering University of California, December 5, 1991.

11. Mondelfo, L.F., "Aluminum Alloys Structures and Properties." Butterworths. Boston, Mass. 1976.
12. Booklet from, "Electrochemical Techniques in Corrosion Engineering", Short Course University of Virginia, 1991.