

TNO-Defensieonderzoek

AD-A256 544



Lange Kleiweg 137
Postbus 45
2280 AA Rijswijk

Fax 015 - 84 39 91
Telefoon 015 - 84 28 42



TNO-rapport

PML 1992-11

August 1992

Copy no.: - 6

Instrumented experiments aboard the frigate "WOLF".
Wolf II: Measurement results of the 3 kg TNT
experiment in the crew front sleeping
compartment

Author (s):

Th.L.A. Verhagen
R.M. van de Kastele

Total Number of Pages :
(ex. distr. list and RDP)

66

Number of Annexes :

-

Number of Figures :

49

Number of Tables :

11

DO assignment no.:

A88/KM/419

Number of Copies :

26

Classification

Report :

UNCLASSIFIED

Title:

UNCLASSIFIED

Summary:

UNCLASSIFIED

Annex(es) :

-

DTIC
ELECTE
OCT 28 1992
S A D

*Original contains color
plates: All DTIC reproduct-
ions will be in black and
white*

Alle rechten voorbehouden.
Niets uit deze uitgave mag worden
vermenigvuldigd en/of openbaar gemaakt
door middel van druk, fotokopie, microfilm
of op welke andere wijze dan ook, zonder
voorafgaande toestemming van TNO.

Indien dit rapport in opdracht werd
uitgebracht, wordt voor de rechten en
verplichtingen van opdrachtgever en
opdrachtnemer verwezen naar de
'Algemene Voorwaarden voor Onderzoeks-
opdrachten aan TNO', dan wel de
betreffende terzake tussen partijen
gesloten overeenkomst.
Het ter inzage geven van het TNO-rapport
aan direct belanghebbenden is toegestaan.

TNO

This document has been approved
for public release and sale; its
distribution is unlimited.

92-28357



Summary

Within the framework of the research into the vulnerability of ships, an experimental investigation took place in 1989 aboard the frigate "WOLF" of the "Roofdierklasse" (PCE 1604 class) (Wolf, Phase II).

In this report the measurement results of an instrumented experiment in the crew front sleeping compartment are presented. During this experiment, a non-fragmenting charge of 3 kg TNT was initiated.

Samenvatting

In het kader van het onderzoek naar de kwetsbaarheid van schepen zijn in 1989 een aantal experimenten uitgevoerd op het fregat "WOLF" van de Roofdierklasse (PCE 1604 class) (Wolf, Fase II).

In dit rapport worden de meetresultaten gepresenteerd van een geïnstrumenteerde beproeving van het manschappenslaapcompartiment op het voorschip. Tijdens dit experiment werd een kale, 3 kg TNT lading tot ontploffing gebracht.

Accession For	
NTIS CRA&I	<input checked="" type="checkbox"/>
DTIC TAB	<input type="checkbox"/>
Unannounced	<input type="checkbox"/>
Justification	
By	
Distribution/	
Availability Codes	
Dist	Avail on
	Special
A-1	

CONTENTS

	SUMMARY/SAMENVATTING	2
	CONTENTS	3
1	INTRODUCTION	5
2	DESCRIPTION OF THE EXPERIMENT	7
2.1	Objective of the experiments	7
2.2	Experimental set-up	7
3	PRESSURE MEASUREMENT	10
3.1	Position of the pressure transducers	10
3.2	Discussion of the pressure measurements	12
4	QUASI-STATIC PRESSURE MEASUREMENT	17
4.1	Position of the quasi-static pressure transducers	17
4.2	Discussion of the quasi-static pressure measurement	19
5	STRAIN MEASUREMENT	23
5.1	Position of the strain gauges	23
5.2	Discussion of the strain measurements	28
6	ACCELERATION MEASUREMENT	41
6.1	Position of the accelerometers	41
6.2	Discussion of the acceleration measurements	43
7	TEMPERATURE MEASUREMENT	57
7.1	Position of the temperature transducers	57
7.2	Discussion of the temperature measurement	58

8	BREAKWIRES	58
8.1	Position of the breakwires	58
8.2	Discussion of the breakwire measurements	59
9	CONCLUSION	61
10	AUTHENTICATION	63
11	REFERENCES	64
11.1	General references	64
11.2	FRET reports	64
11.3	WOLF, phase I reports	64
11.4	WOLF, phase II reports	65
11.5	Roofdier Blast damage reports	66

1 INTRODUCTION

In order to obtain quantitative as well as qualitative information on the effects of internal and external explosions on a frigate, a number of (instrumented) experiments were performed on the frigates "FRET" and "WOLF" (Figure 1). These are Roofdier class frigates, the former United States Navy PCE 1604 class, which were decommissioned by the Royal Netherlands Navy. A general overview of the Roofdier trials is given in Table 1.

Table 1 A general overview of the Roofdier trials

Fret I	June/September 1987	(v.d. Kastele and Verhagen, 1989)
Wolf I	October/ November 1988	(v.d. Kastele and Zwaneveld, 1989)
Wolf II	September/October 1989	(Verhagen and v.d. Kastele, 1992)

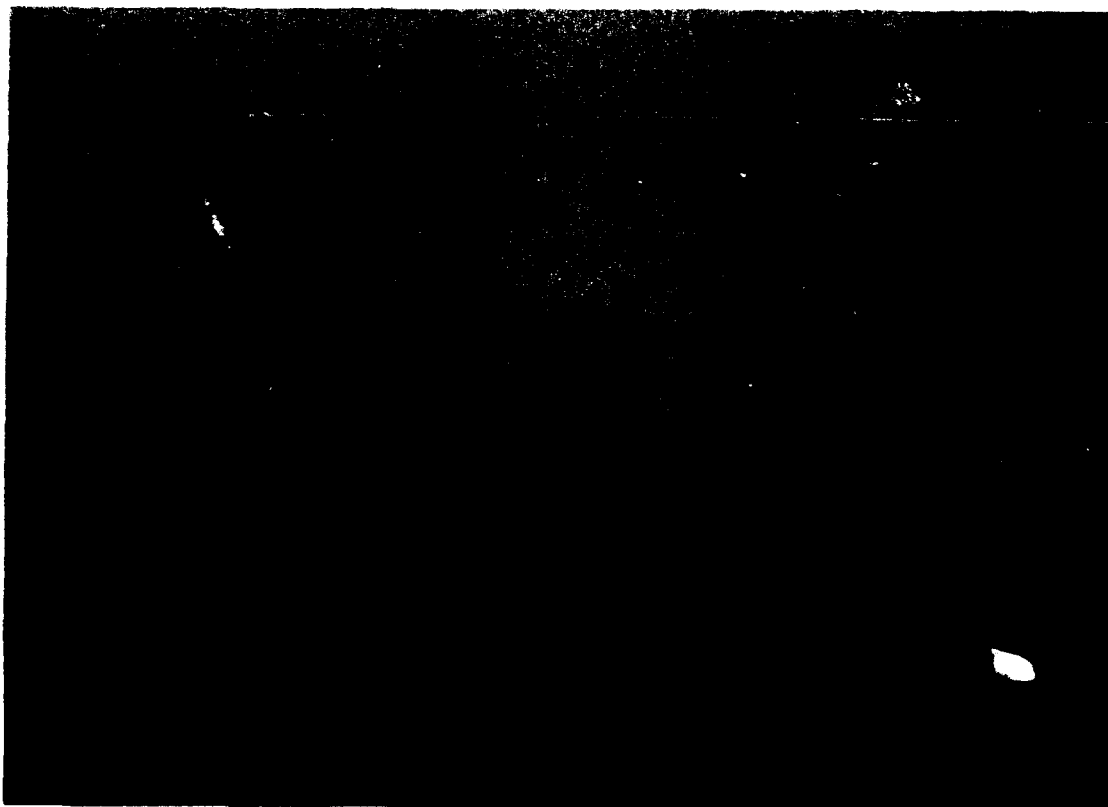

Figure 1 Wolf frigate (891052-7)

Pressure, strain, acceleration etc. were recorded during the Wolf Phase II bare charge experiments. These experiments were performed in the crew aft as well as the crew forward sleeping compartment. In the crew aft sleeping compartment, the 2, 5.5 and 15 kg TNT bare charge experiments were performed on one day. The volume of this compartment was $\pm 77 \text{ m}^3$, thus realizing a "charge density" of ± 0.026 , ± 0.072 and $\pm 0.20 \text{ kg/m}^3$.

The 3 and 12 kg TNT bare charge experiments were also performed in the crew forward sleeping compartment on one day. The volume of this compartment was $\pm 105 \text{ m}^3$, thus resulting in a "charge density" of ± 0.029 and $\pm 0.11 \text{ kg/m}^3$.

During these Phase II experiments, special attention was paid to the blast resistance of the watertight doors (i.e. the 2, 3 and 5.5 kg TNT experiments), the resistance of the structure (the 12 kg TNT experiment) and the rupture of structural elements (the 15 kg TNT experiment).

The recordings of the instrumented Wolf Phase II experiments presented conform to the previous reports dealing with the recordings of the Fret and Wolf Phase I experiments. Each report can be regarded as an individual report. It goes without saying that it is not within the scope of these reports to discuss the recordings in detail or even to compare the recordings with theoretical predictions. That will be an integral part of the reports presented by van Erkel (1992).

Nevertheless, some additional information is given concerning the reliability of the presented recordings.

Due to the increased knowledge and experience gained from the Fret and Wolf Phase I trials, modified mounting and protection techniques were used during the Wolf Phase II trial. It is for this reason that a separate report deals with the general background information as well as the mounting and protection methods used. For the sake of completeness, a description is also given of the registration equipment and the signal analyses system used.

This report deals with the bare 3 kg TNT experiment in the crew forward sleeping compartment.

Some general remarks are made of the experiment in Chapter 2, as well as some specific information on the charge used. In the following chapters, the recordings are presented.

Offset elimination was carried out. The time axis used was related to the moment of ignition of the charge ($t=0$).

Because the 3 and 12 kg TNT experiments in the crew forward sleeping compartment were performed in one day, no time remained between the experiments for the technicians to adjust the

settings of the registration equipment. It is for this reason that the settings of the registration equipment for the 3 kg TNT experiment were based on the predictions of the maximum charge (12 kg TNT) to be used that day. However this can have an effect on the signal-to-noise ratio recorded during this 3 kg TNT experiment.

Some abbreviations often used are BHD (Bulkhead), SB (Starboard), PS (Portside) and CL (Centre line frigate).

2 DESCRIPTION OF THE EXPERIMENT

2.1 Objective of the experiments

One of the objectives of the ROOFDIER trials is the validation of the computer code "DAMINEX" as developed by the Weapon Effectiveness Department of the TNO - Prins Maurits Laboratory.

The DAMINEX code determines the structural damage to a frigate due to internal blast. A number of theoretical assumptions were made during the development of this code, which however may have a large influence on the final simulation results.

In general, the damage caused by the experiments is registered visually. It is for this reason that a lack of quantitative information is still apparent. The specific goal of the ROOFDIER experiments is to gain more quantitative as well as qualitative information by performing well-documented experiments. This information will be used to validate (or even modify) the DAMINEX code.

2.2 Experimental set-up

Two crew sleeping compartments were chosen by the Weapon Effectiveness Department for the instrumented experiments: the crew forward sleeping compartment and the crew aft sleeping compartment. These two compartments correspond with the crew sleeping compartments used during the FRET experiments. As a consequence, these experiments can be compared with the FRET experiments, although during the latter, (bare) charges of 8 kg and 12 kg TNT were used.

The crew forward sleeping compartment (height: 2.25 m, length: 5.5 m, width: 8.35 m - 9.35 m) was cleared as much as possible of all obstacles. Preceding the experiments, a venting hole (diameter 20 cm) was made in the centre of the SB hull of the compartment in which the experiment took place to simulate the hull's penetration by a warhead.

The charge used during this experiment was composed of six rectangular blocks of 500 grams TNT each (size: $45.6 \times 70.8 \times 105.0 \text{ mm}^3$) resulting in a 3 kg TNT rectangular charge (size: $136.8 \times 141.6 \times 105 \text{ mm}^3$). The charge was placed in the centre of the compartment at midheight. The direction of the centre line of the frigate corresponds with the 141.6 mm side of the charge. The charge was ignited with one electrical detonator (No. 8) and a booster of three RDX cartridges ($L/D=1$, $D=50 \text{ mm}$) placed in the bottom of one of the rectangular blocks as indicated in Figure 2. The geometry and an impression of the charge are shown schematically in Figures 2 and 3. Figure 4 shows the compartment after the experiment was performed.

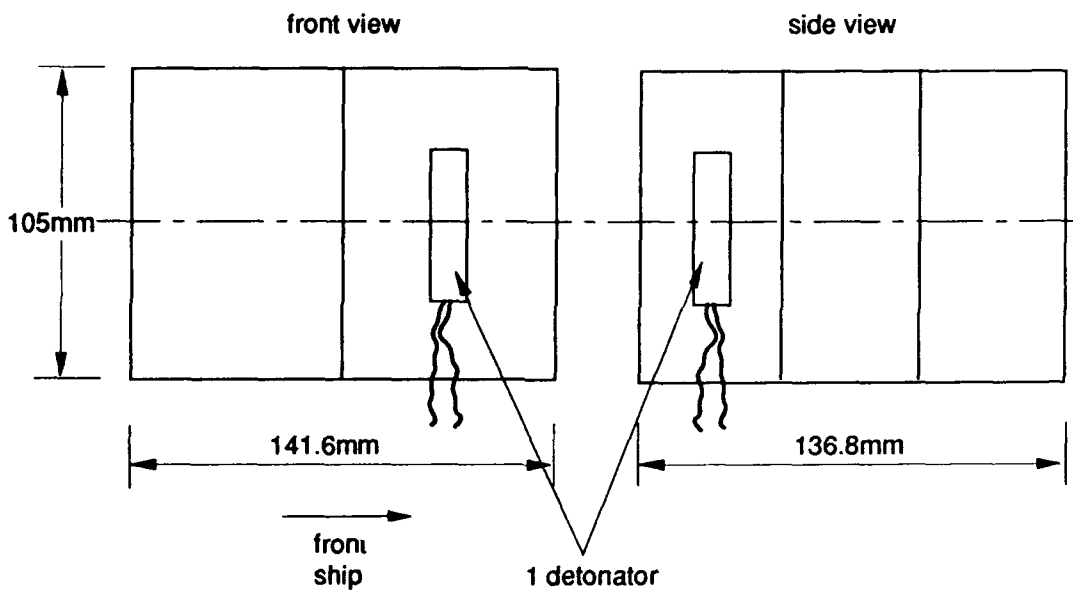

Figure 2 Geometry of the charge

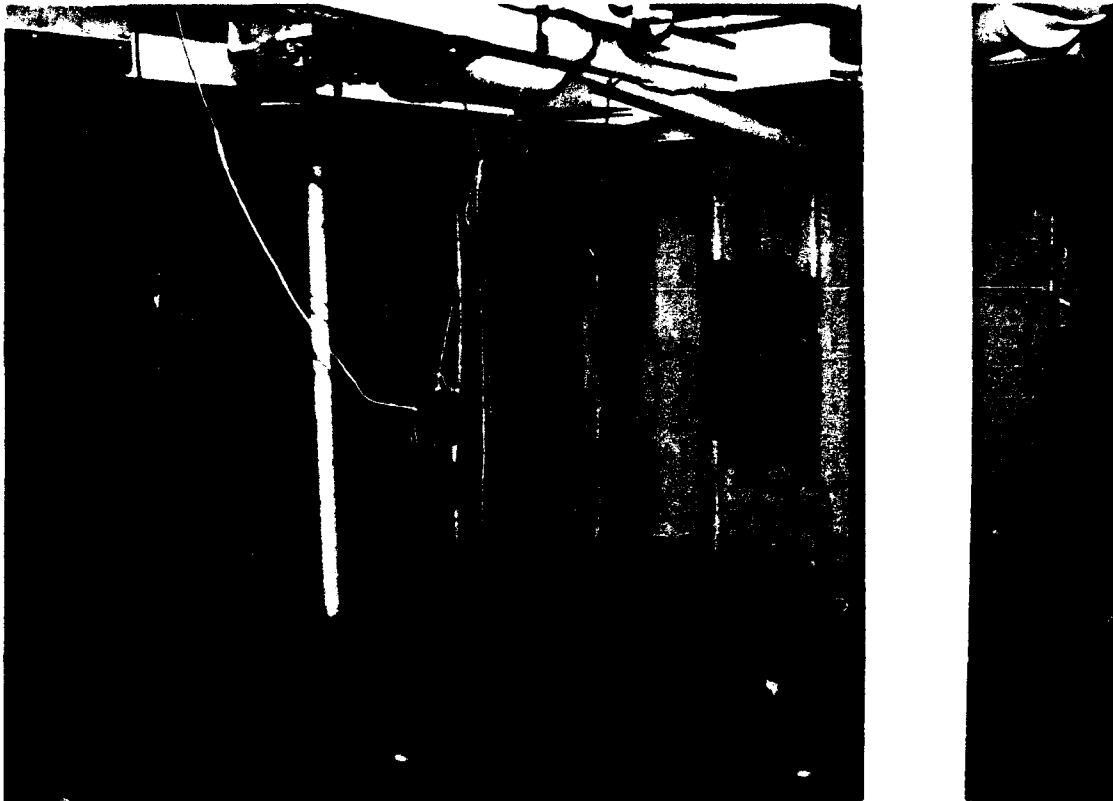

Figure 3 Impression of the experimental set-up

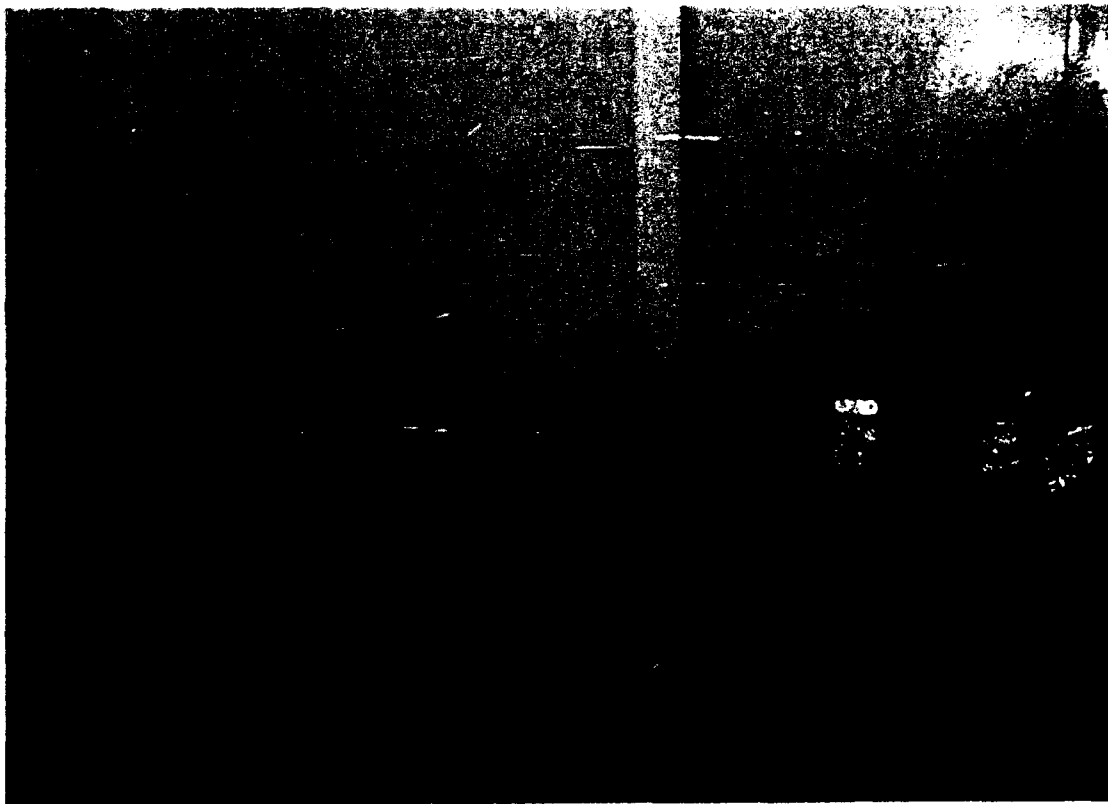

Figure 4 The compartment after the experiment was performed

3 PRESSURE MEASUREMENT

3.1 Position of the pressure transducers

To measure the overpressure, six piezo-electric pressure transducers B1-B6 were used, all mounted in the experiment compartment. B1 and B2 were mounted on the hull of the frigate whereas B3-B5 were mounted on bulkhead 32. B6 was mounted in the ceiling of the compartment. The transducers were mounted at about midheight in the compartment, the positions are summarized in Table 2 and shown schematically in Figures 5 and 6.

Table 2 Position of pressure transducers

Device	Height	Mounting position
B1 (*)	112 cm	on hull SB, 179 cm from BHD 23 on stiffener
B2	114 cm	on hull PS, 184 cm from BHD 23 on stiffener
B3	112 cm	on BHD 32, 63 cm from CL
B4	112 cm	on BHD 32, 174 cm from CL
B5	112 cm	on BHD 32, 286 cm from CL
B6	ceiling	40 cm from SB, 42 cm from BHD 32

(*) in vicinity of the venting hole

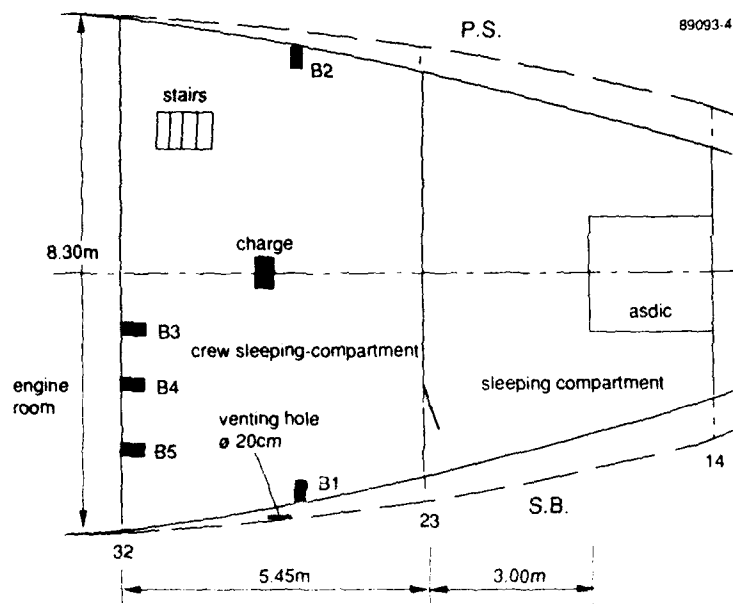

Figure 5 Schematic illustration of the position of the pressure transducers

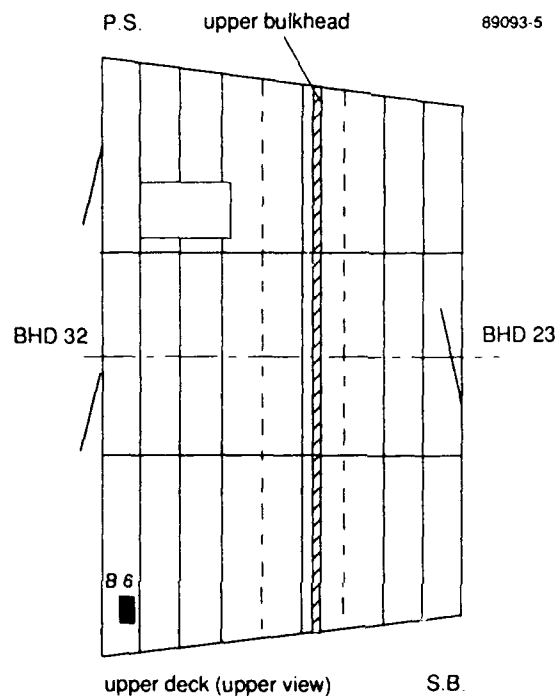

Figure 6 Schematic illustration of the position of the pressure transducer B6

3.2 Discussion of the pressure measurements

The recorded pressure signals are presented in Figures 7, 8 and 9. A significant signal-to-noise ratio is noticeable (B2, B3, B4, B6). This is due to the equipment settings which were related to the 12 kg TNT experiment later that day. The recorded peak pressures and the arrival times are given in Table 3.

Theoretical predictions of peak pressure and arrival time are also presented in this table. They are based on a centrally ignited, spherical charge (Baker 1983, Figures 2.45 and 2.46), in spite of the exact geometry of the charge.

From this table a reasonable correspondence between experimental first peak and theoretical peak pressure is evident. The slight discrepancies noticeable in the arrival times may be due to the geometry of the charge. Symmetric with respect to the charge, mounted devices B1 and B2 show a close resemblance.

The stiffeners on the bulkheads were in the experiment compartment, in contrast with the crew aft sleeping compartment. Due to these stiffeners the shock wave will be reflected, which is apparent in the recordings.

Table 3 Comparison of experimental and theoretical (first) peak pressure and arrival time

Device	d(D,C) [m]	Z [m/kg ^{1/3}]	Peak pressure		Arrival time	
			Exp. [kPa]	Theor. [kPa]	Exp. [ms]	Theor. [ms]
B1(1)	3.90	2.71	324	280	4.4	4.5
B2	3.90	2.71	290	280	4.0	4.4
B3	2.80	1.94	820	800	1.9	2.6
B4	3.35	2.32	712	450	3.8	3.5
B5	4.00	2.77	417	260	5.8	4.6
B6	4.80	3.33	178	155	7.0	6.3

d(D,C) : distance between Device and Charge

Z : scaled distance [m/kg^{1/3}]

(1) : in vicinity of venting hole

: Theoretical predictions for a centrally ignited, spherical charge (Baker 1983, Figures 2.45 and 2.46)

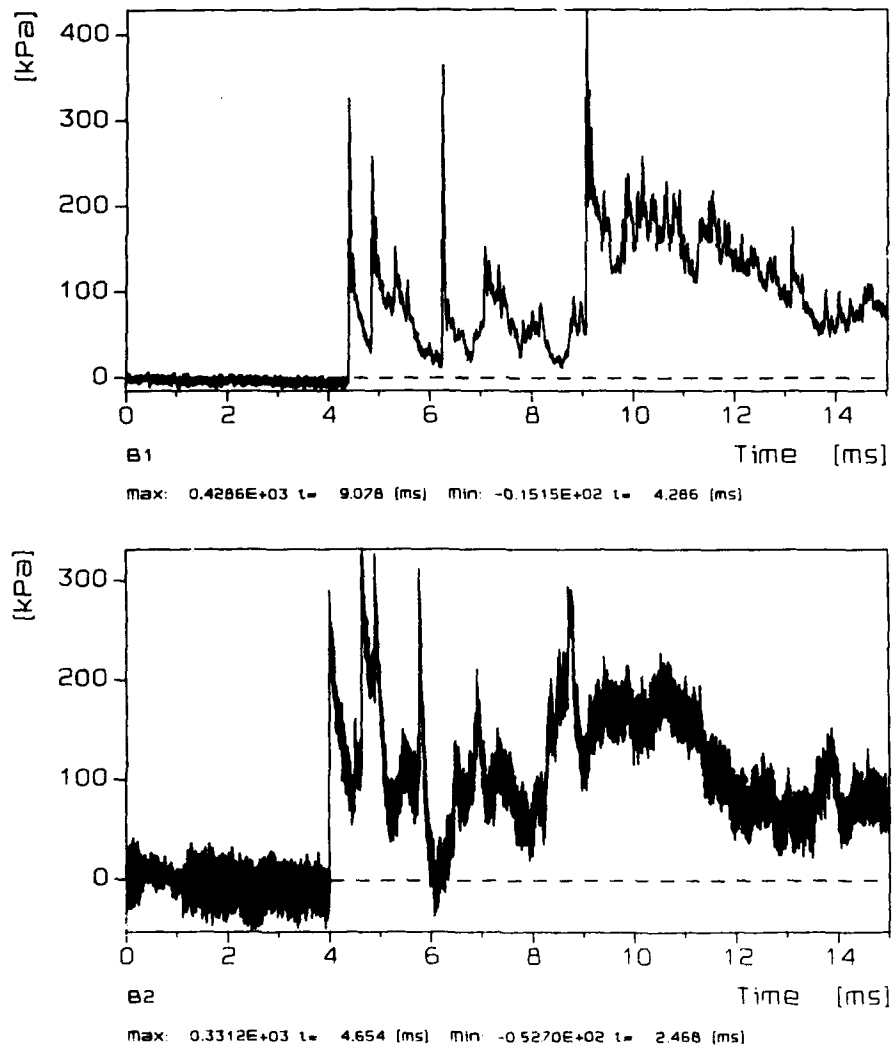
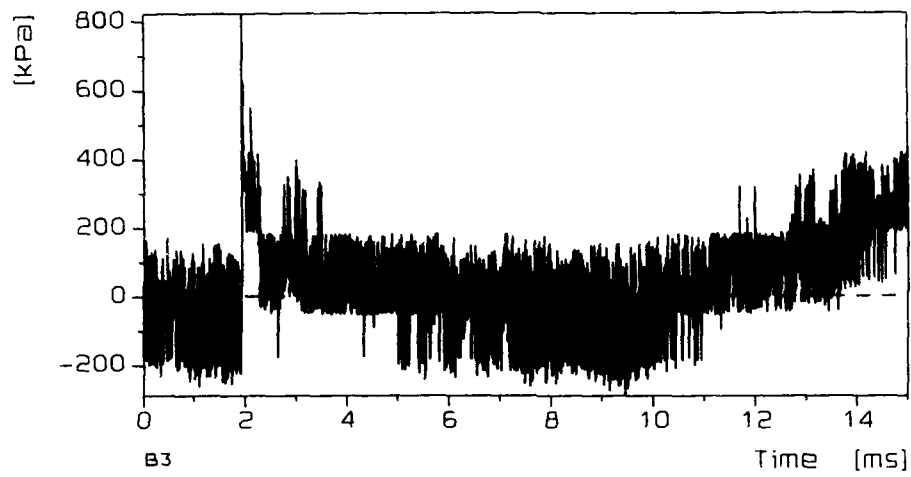
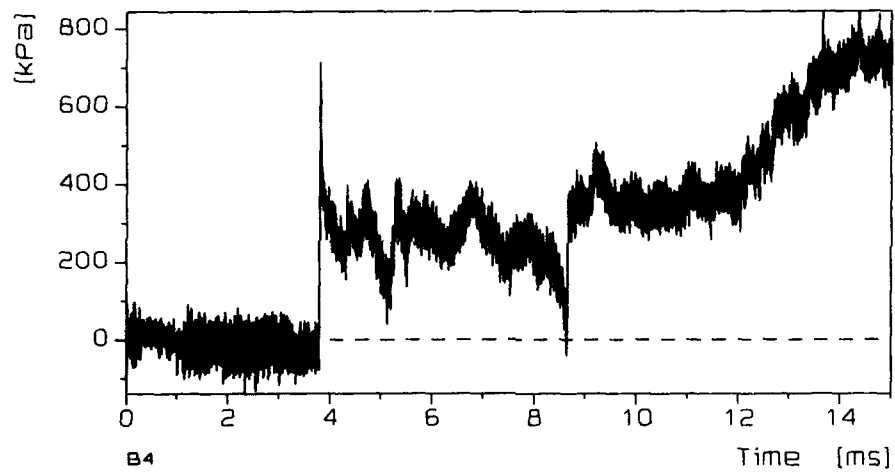

Figure 7 Pressure signals B1 (SB hull) and B2 (PS hull)



max: 0.8223E+03 t= 1.936 [ms] Min: -0.2889E+03 t= 9.458 [ms]



max: 0.8434E+03 t= 13.668 [ms] Min: -0.1404E+03 t= 2.344 [ms]

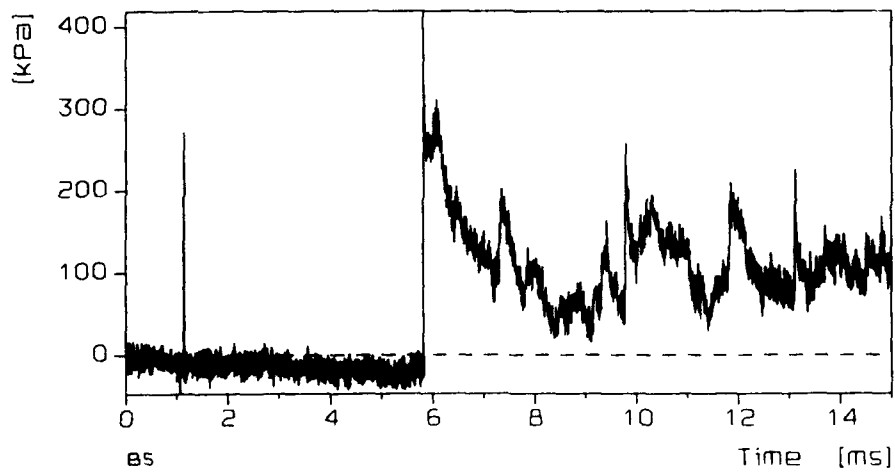

max: 0.4186E+03 t= 5.832 [ms] Min: -0.4744E+02 t= 1.062 [ms]

Figure 8 Pressure signals B3, B4 and B5 (BHD 32)

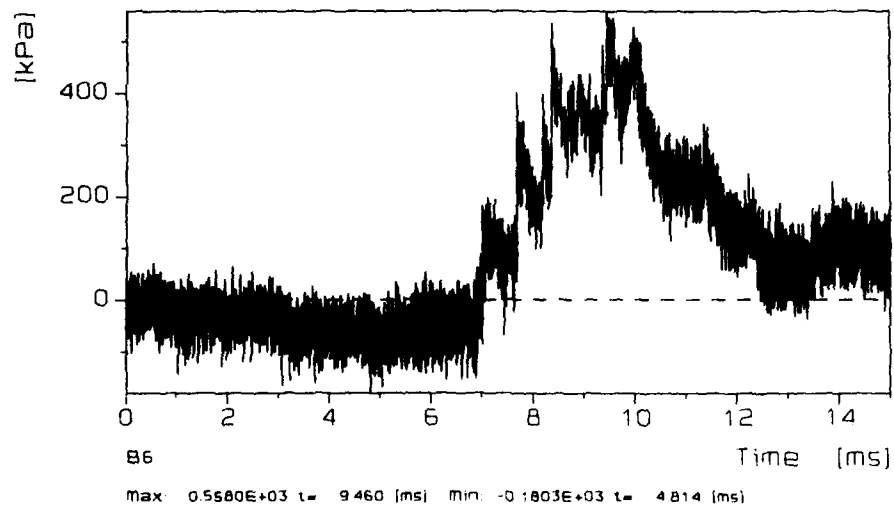

Figure 9 Pressure signals B6 (ceiling corner)

4 QUASI-STATIC PRESSURE MEASUREMENT

4.1 Position of the quasi-static pressure transducers

The quasi-static pressure was registered with piezo resistive transducers at six different locations (Q1-Q6). Two transducers (Q1, Q2) were placed in the crew forward sleeping quarters. The other transducers were placed in the neighbouring compartments, i.e. three transducers (Q3, Q4, Q5) in the corporals' sleeping quarters/mess, one (Q6) in the officers' room which is located above the experiment compartment. The positions of the transducers are summarized in Table 4 and shown schematically in Figures 10 and 11.

Table 4 Position of the quasi-static pressure transducers

Device	Height	Position
Q1 ⁽¹⁾	128 cm	14 cm in front of the hull, SB
Q2	127 cm	14 cm in front of the hull, PS
Q3	107 cm	320 cm behind door on frame 18, SB
Q4	100 cm	52 cm from CL, on wall ASDIC room
Q5	113 cm	150 cm from BHD 14, on wall ASDIC room
Q6	114 cm	44 cm from door in BHD 32 in officers' room

(1) in vicinity of the venting hole

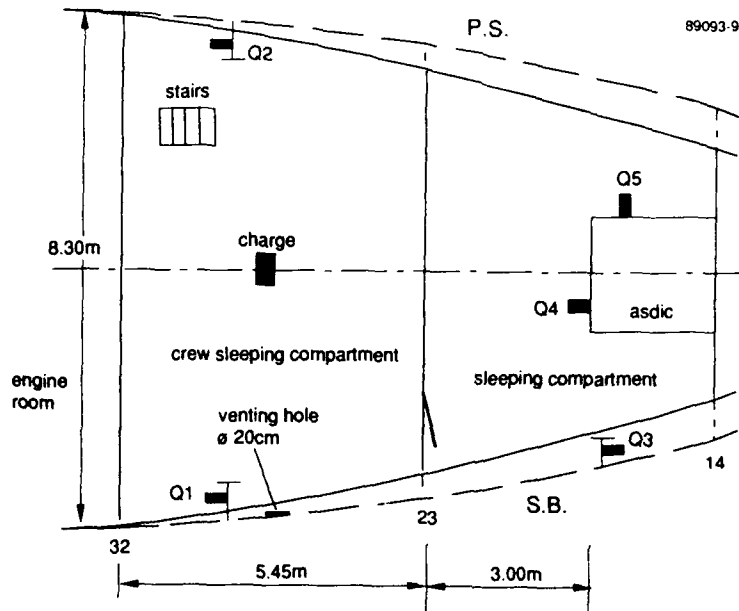

Figure 10 Schematic illustration of the position of the quasi-static pressure transducers

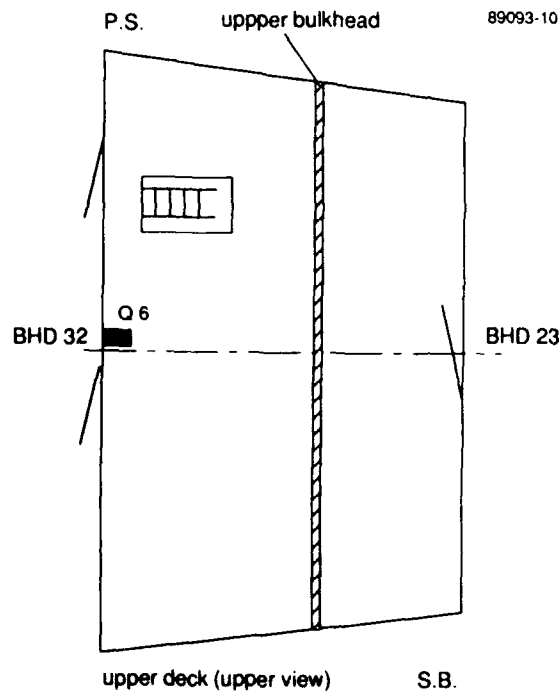

Figure 11 Schematic illustration of the position of the quasi-static pressure transducers

4.2 Discussion of the quasi-static pressure measurement

The quasi-static pressure recordings Q1 and Q2 are presented in Figures 12 and 13. The signal-to-noise ratio was strongly influenced by the settings of the equipment, which were based on the 12 kg TNT experiment later that day. Using a uniform filtering improved the results considerably.

The recorded quasi-static pressure signals Q3-Q6 contain no relevant information. Slight pressure fluctuations were measured, probably due to some leakage. It is for this reason that these recordings were omitted from this report.

In Table 5, the arrival time T_a , the maximum quasi-static pressure P_{max} and time T_{max} are summarized for transducers Q1 and Q2. A comparison with theoretical values is possible for Q1 and Q2 because these transducers were mounted in the experiment compartment. Using Baker (1983, Figure 3.15), a theoretical peak pressure of 150 kPa is found, based on 3 kg TNT and a

room volume of 105 m^3 . Using the Weibull expression leads to 174 kPa. Comparing these values with the experimental values shows a good agreement.

Table 5 Quasi-static pressure measurement

Device	T_a [ms]	P_{\max} [kPa]	T_{\max} [s]
Q1	4.9	120	0.1
Q2	4.9	120	0.1

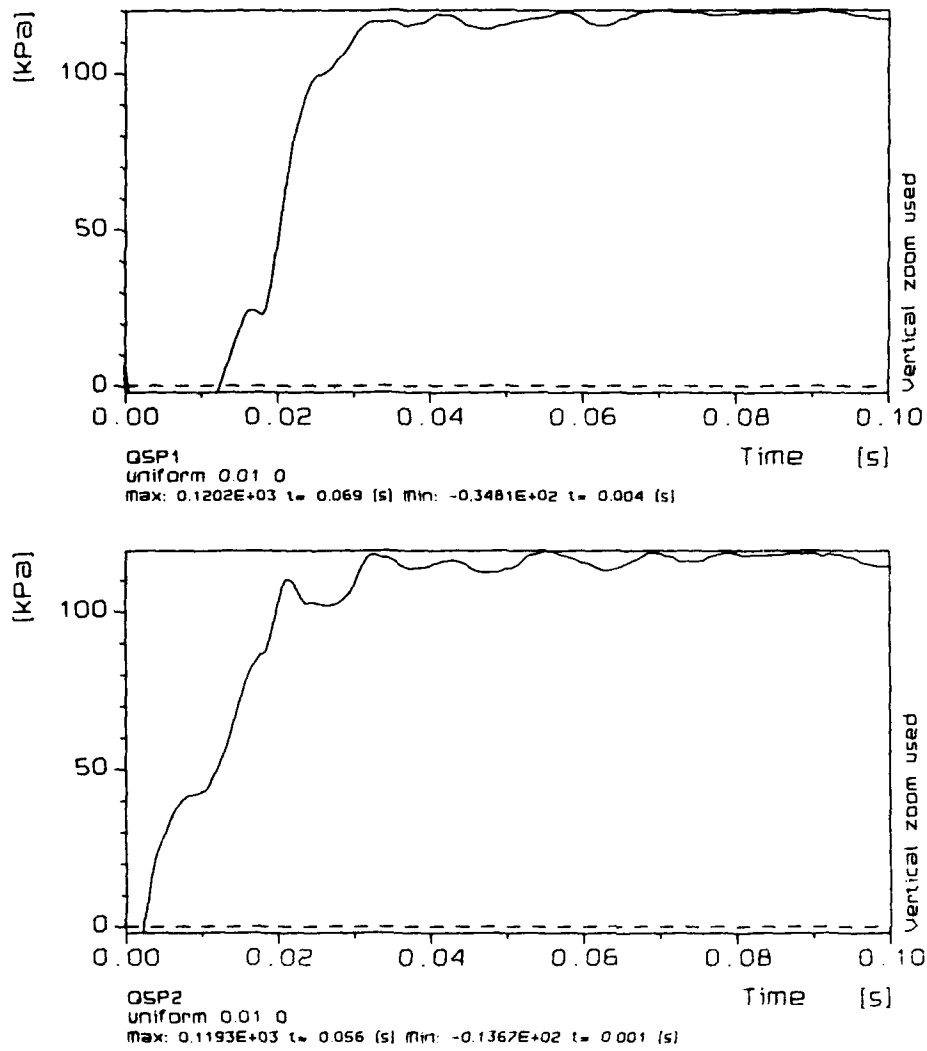

Figure 12 Quasi-static pressure signals Q1 and Q2 (experiment compartment) (short time base)

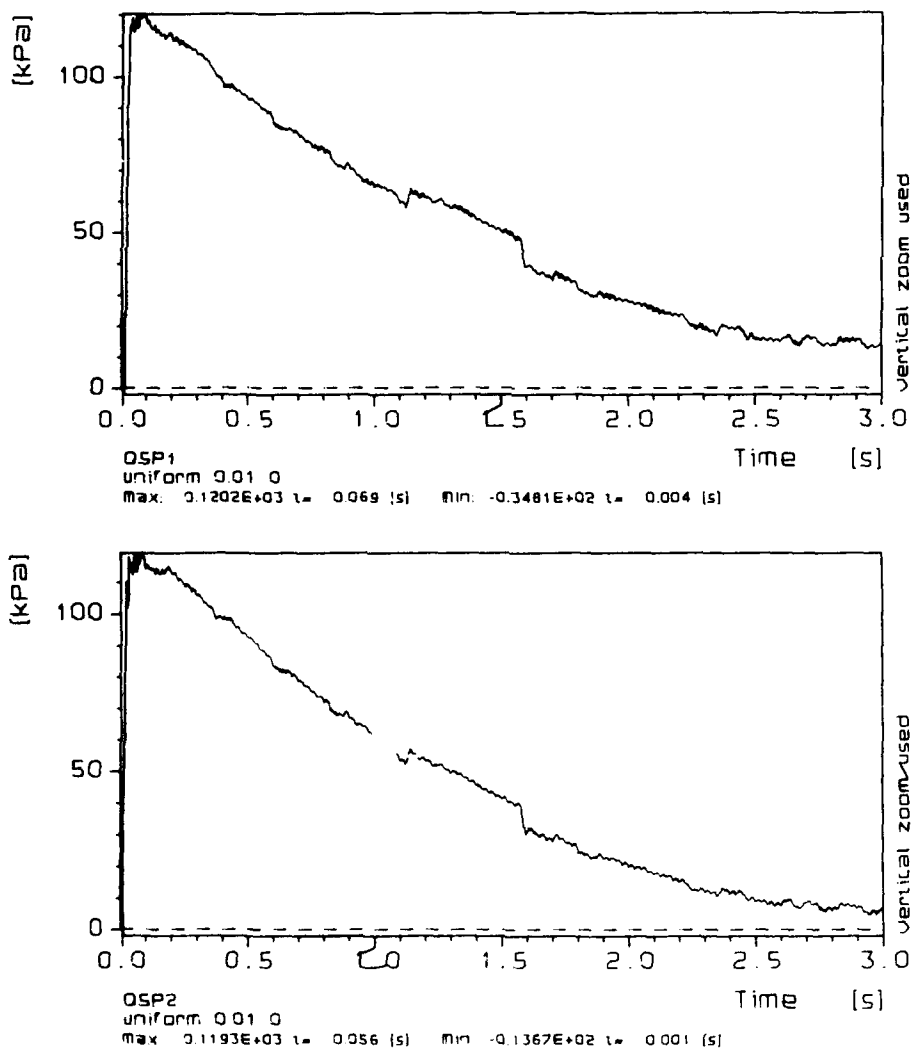

Figure 13 Quasi-static pressure signals Q1 and Q2 (experiment compartment)

5 STRAIN MEASUREMENT

5.1 Position of the strain gauges

The strain was measured using eight 2% and nineteen 10% strain gauges in twenty-seven positions (S1-S27) during the experiment. Some of the strain gauges were placed singly, while others were placed in pairs, opposite each other.

The positions of the strain gauges are summarized in Tables 6-9 and shown schematically in Figures 14-18; a subdivision was used.

To visualize the location of the strain gauges, the following notation is used:

- : 2% strain gauge, single, front side
- : 2% strain gauge, single, back side
- d ■ : 2% strain gauge, double, both sides

- : 10% strain gauge, single, front side
- : 10% strain gauge, single, back side
- d —■— : 10% strain gauge, double, both sides

The "front side" or "back side" description is related to the plane of view as shown in the figures.

Table 6 Position of the strain gauges on the hull (all in experiment compartment)

Device	Range	Height	Mounted on:
S1	2%	96 cm	Frame 29, midheight, SB
S2	2%	97 cm	Frame 29, midheight, PS

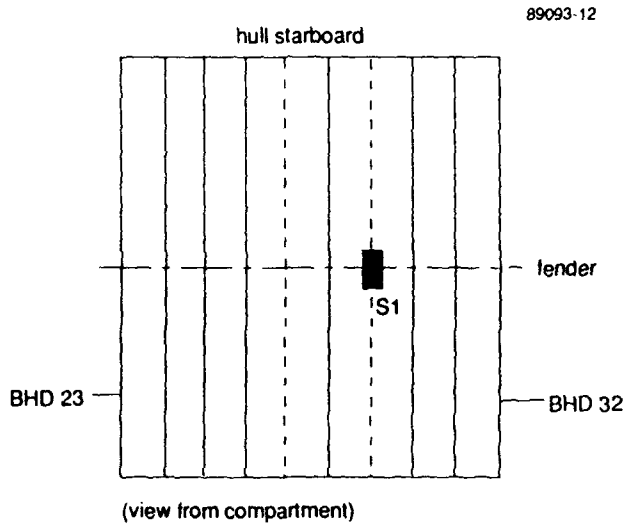

Figure 14 Schematic illustration of strain gauge position S1 (SB)

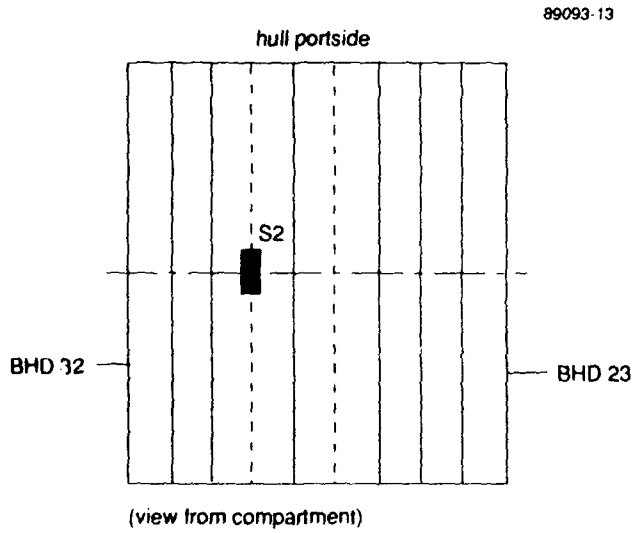

Figure 15 Schematic illustration of strain gauge position S2 (PS)

Table 7 Strain gauges position on BHD 23

Device	Range	Opposite	Height	Mounted on:
S3	10%	---	82 cm ⁽²⁾	31 cm from door case
S4(1)	10%	S5	7 cm ⁽³⁾	8 cm from stiffener
S5	10%	S4	6 cm ⁽³⁾	
S6(1)	10%	S7	112 cm	26 cm from stiffener
S7	10%	S6	112 cm	
S8(1)	10%	S9	112 cm	8 cm from stiffener
S9	10%	S8	112 cm	
S10(1)	10%	S11	113 cm	centre stiffener
S11	10%	S10	112 cm	
S12(1)	10%	S13	7 cm	26 cm from stiffener
S13	10%	S12	7 cm	
S14(1)	10%	S15	7 cm	8 cm from stiffener
S15	10%	S14	7 cm	
S16	10%	---	7 cm	back of stiffener
S17(4)	2%	S18	15 cm	back of stiffener
S18(4)	2%	S17	15 cm	on stiffener
S19(4)	2%	S20	40 cm ⁽³⁾	back of stiffener
S20(4)	2%	S19	40 cm ⁽³⁾	on stiffener

- (1) in experiment compartment
(2) from bottom side door
(3) beneath ceiling
(4) in officers' room above experiment compartment

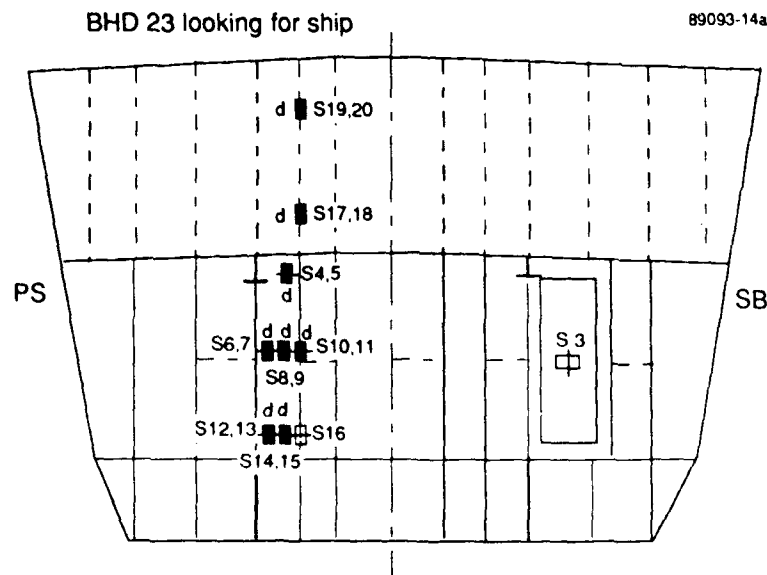

Figure 16 Schematic illustration of strain gauge positions on BHD 23

Table 8 Strain gauge positions on BHD 32

Device	Range	Opposite	Height	Mounted on:
S21(1)	10%	---	217 cm	in machine room
S22	2%	S23	120 cm	back stiffener officers' galley
S23	2%	S22	120 cm	stiffener officers' mess

(1) from ceiling

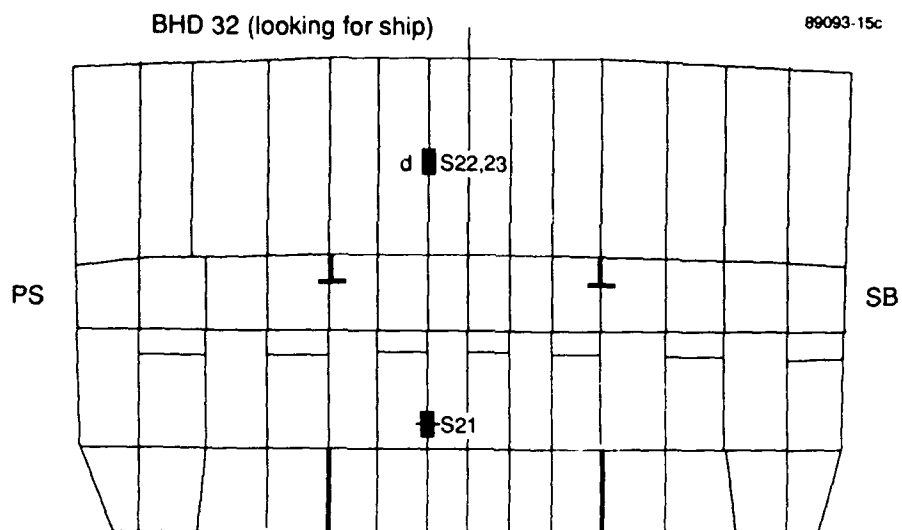

Figure 17 Schematic illustration of strain gauge positions on BHD 32

Table 9 Strain gauge positions on floor officers compartment above experiment compartment

Device	Range	Mounted on:
S24	10%	5 cm from SB, 181 cm from BHD 32
S25	10%	3 cm from SB girder, 308 cm from BHD 32
S26	10%	4 cm from SB girder, 181 cm from BHD 32
S27	10%	back of SB girder, 177 cm from BHD 32

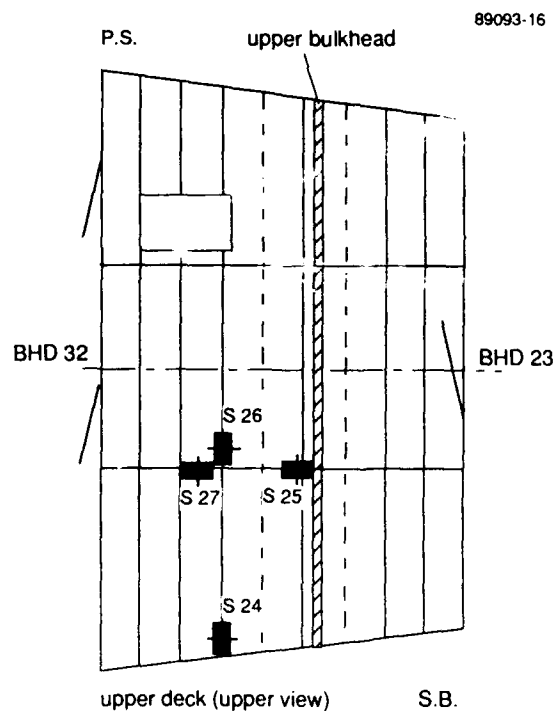

Figure 18 Schematic illustration of strain gauge positions on floor officers compartment which is located above the experiment compartment

5.2 Discussion of the strain measurements

The strain signals are shown on two different time-scales, i.e. 300 ms and 3 s. Opposite-mounted strain gauges are depicted in one figure, enabling a better understanding of the behaviour. S9, S10, S13 and S27 are omitted due to their malfunction during the experiment.

From these figures it can be concluded that both elasto-plastic and elastic deformation responses were recorded. *Some of the recordings drift, which may be due to thermal influences.* From the figures it appears that most couples of strain gauges show an 'in-phase' response, whereas other couples show an 'anti-phase' response. This different response can be explained as follows. The plate is part of the girder and acts as one of the flanges. Consequently, a bending vibration in the girder is observed as an 'in-phase' vibration in the plate near the girder. The 'anti-phase' response indicates that the strain gauges are outside the influence zone of the girder.

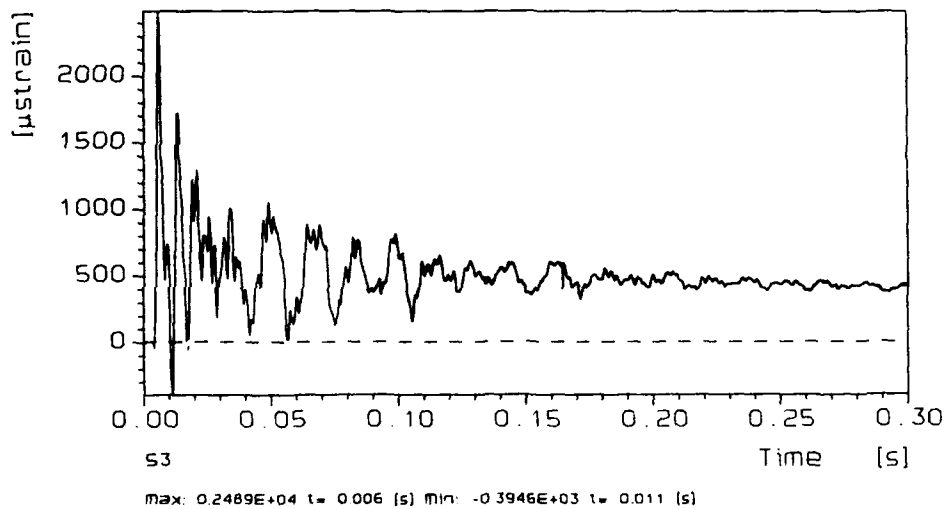
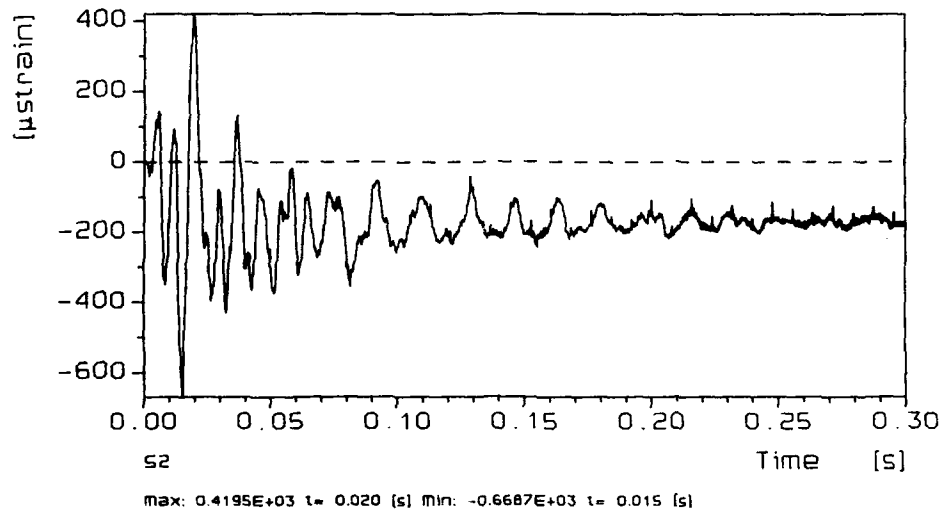
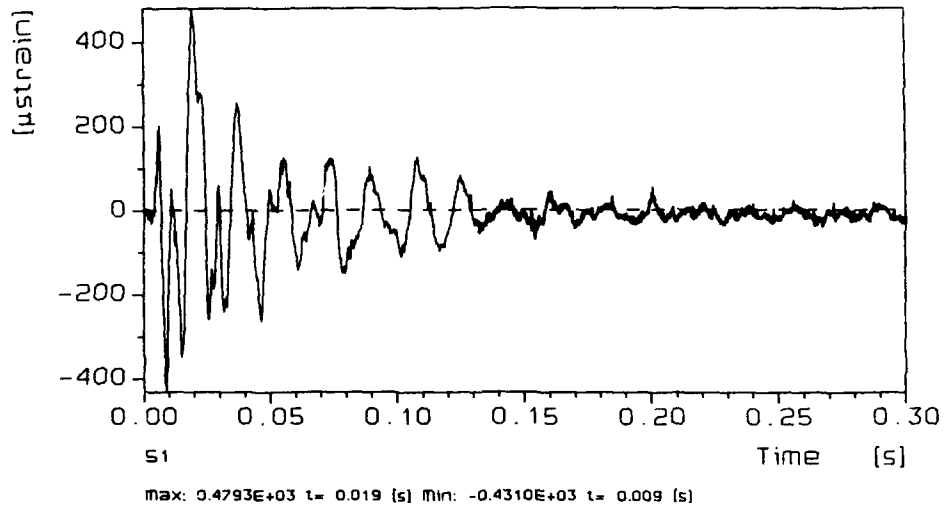

Figure 19 Strain gauge response S1, S2 (experiment compartment), S3 (BHD 23) (300 ms base)

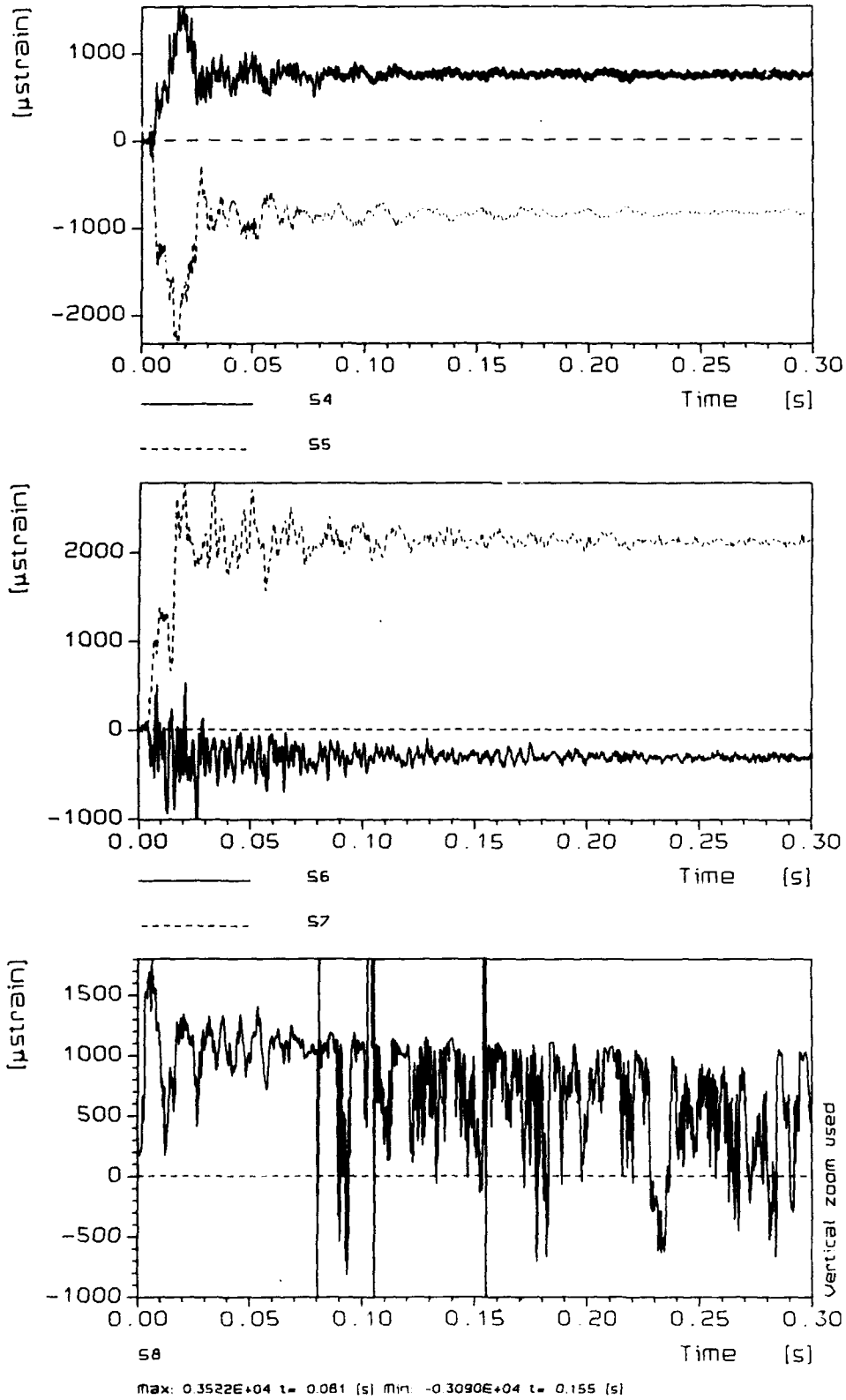

Figure 20 Strain gauge response S4 and S5, S6 and S7, S8 and S9 (BHD 23) (300 ms base)

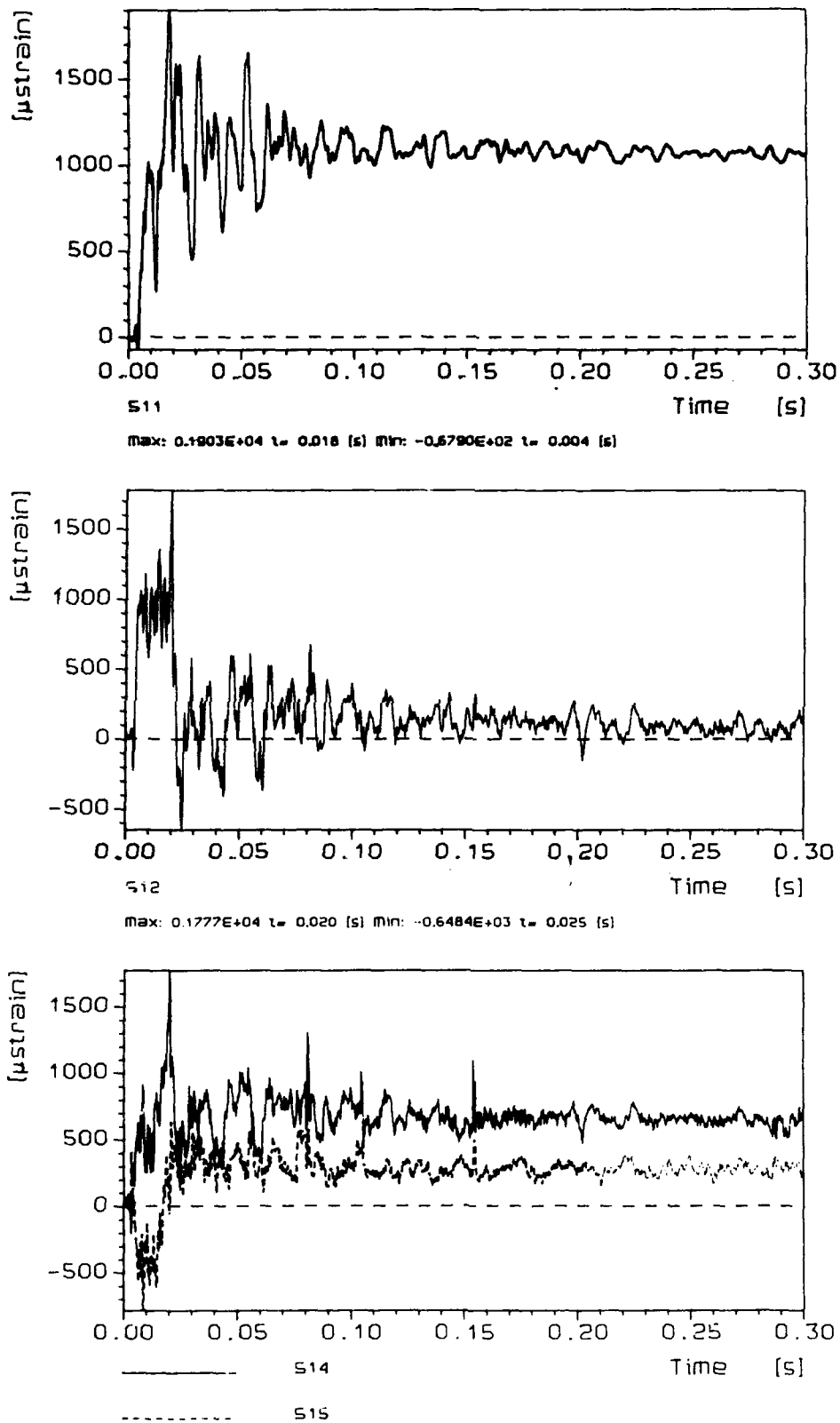

Figure 21 Strain gauge response S11, S12, S14 and S15 (BHD 23) (300 ms base)

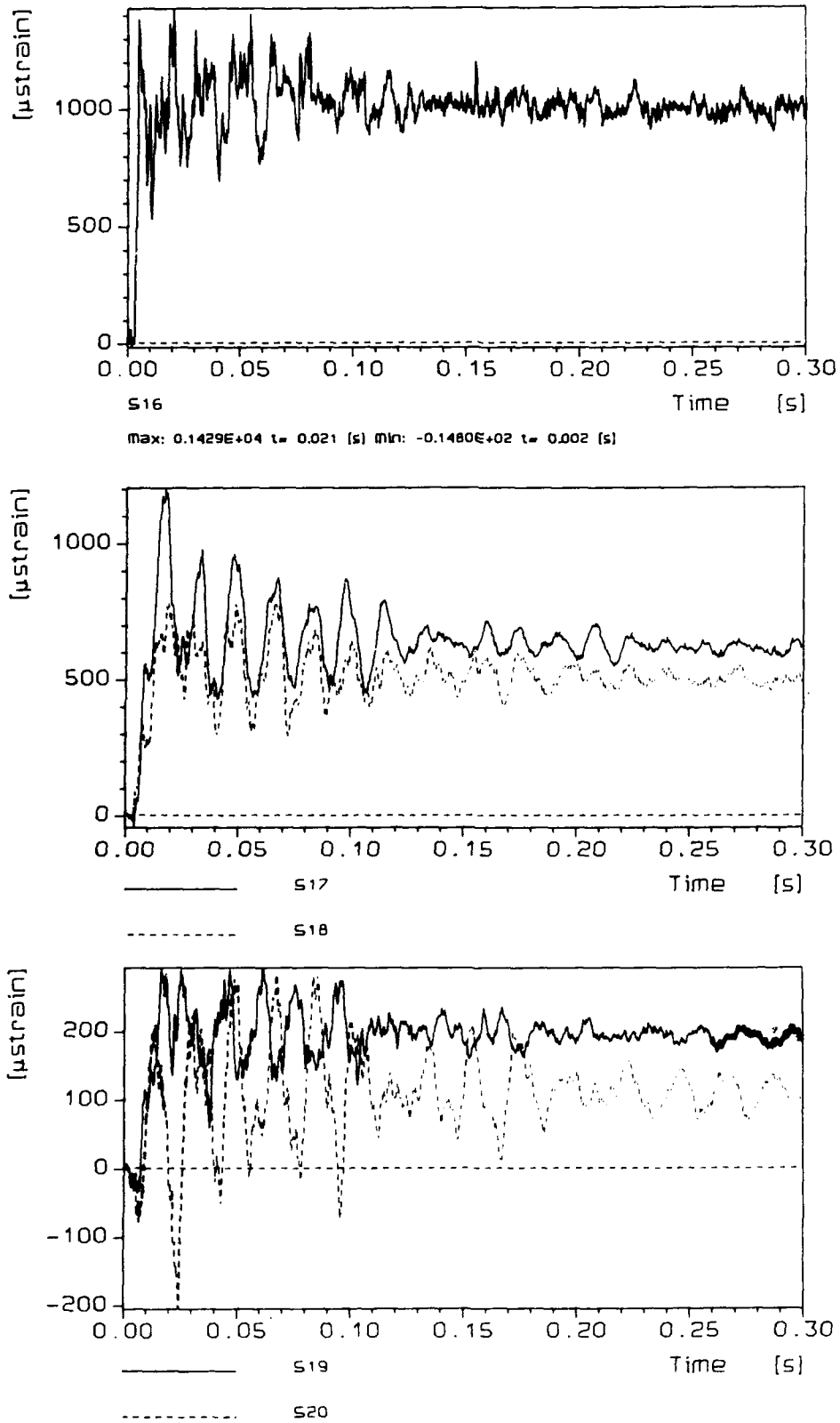

Figure 22 Strain gauge response S16, S17 and S18, S19 and S20 (BHD 23) (300 ms base)

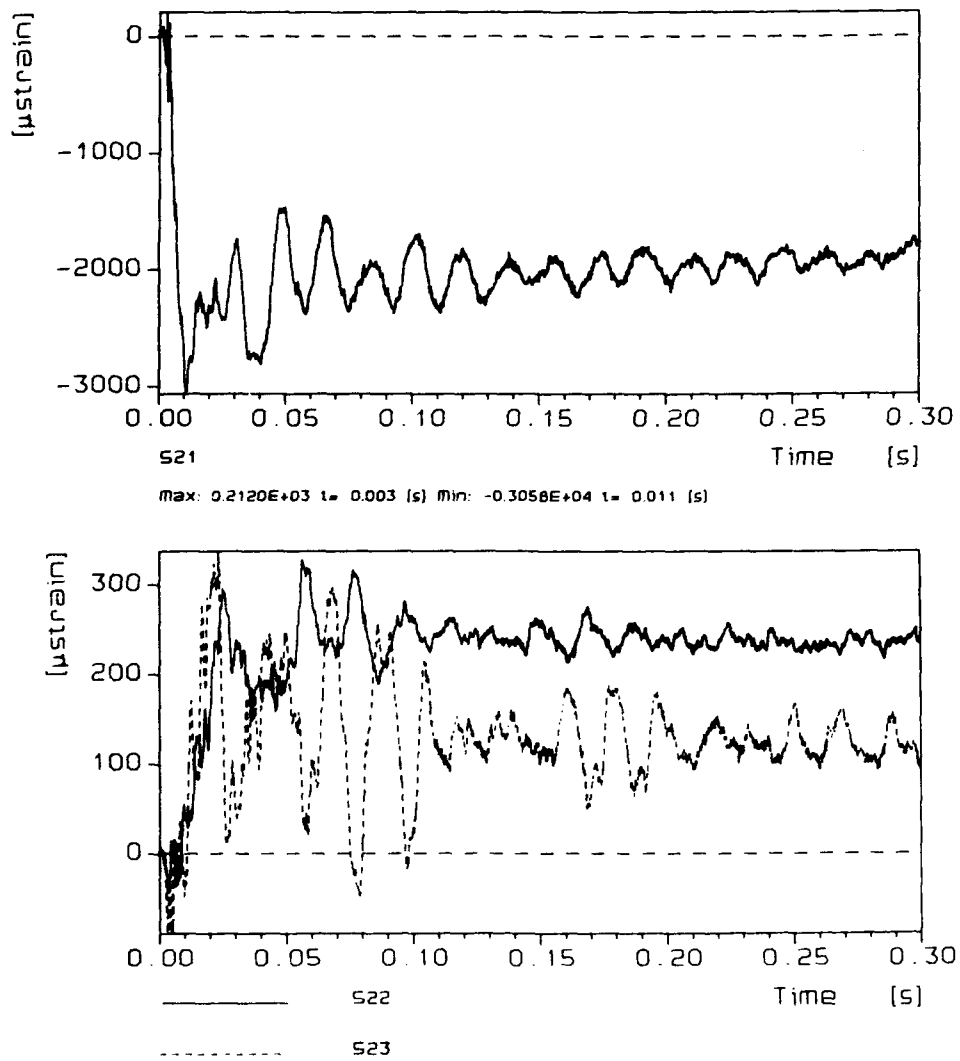

Figure 23 Strain gauge response S21, S22 and S23 (BHD 32) (300 ms base)

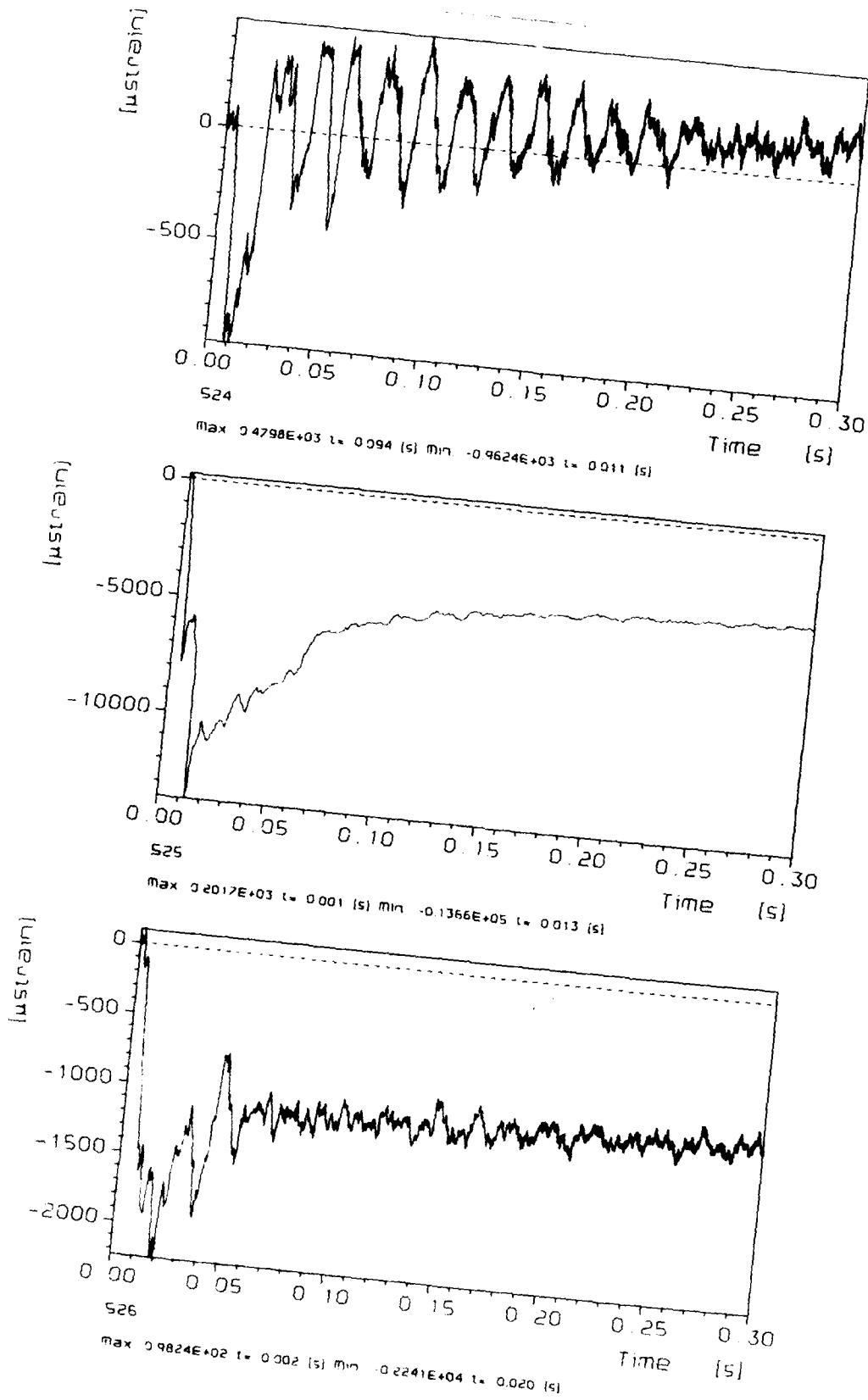

Figure 24 Strain gauge response S24, S25, S26 (floor officers' compartment) (300 ms base)

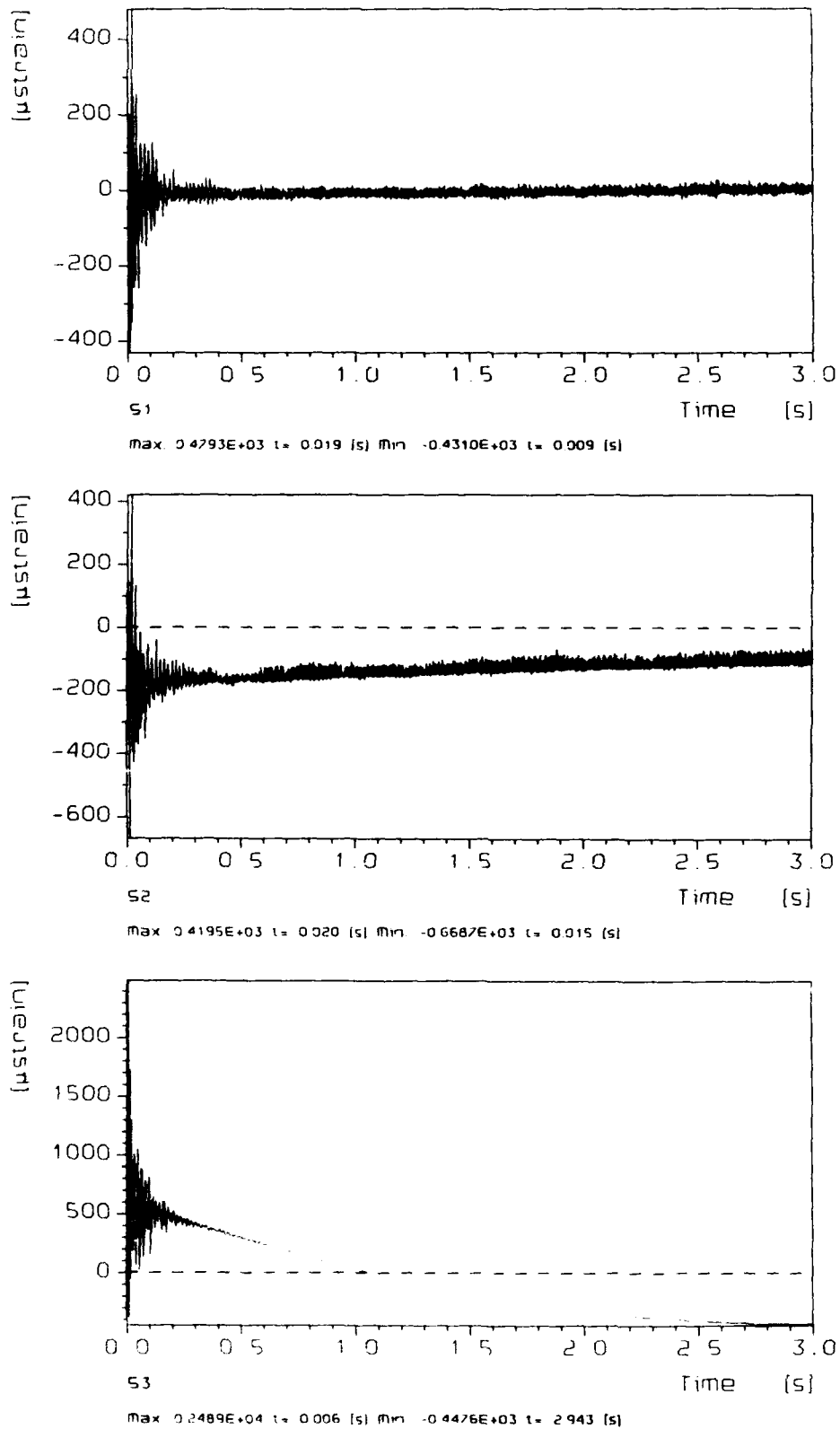

Figure 25 Strain gauge response S1, S2 (experiment compartment), S3 (BHD 23) (3.0 s base)

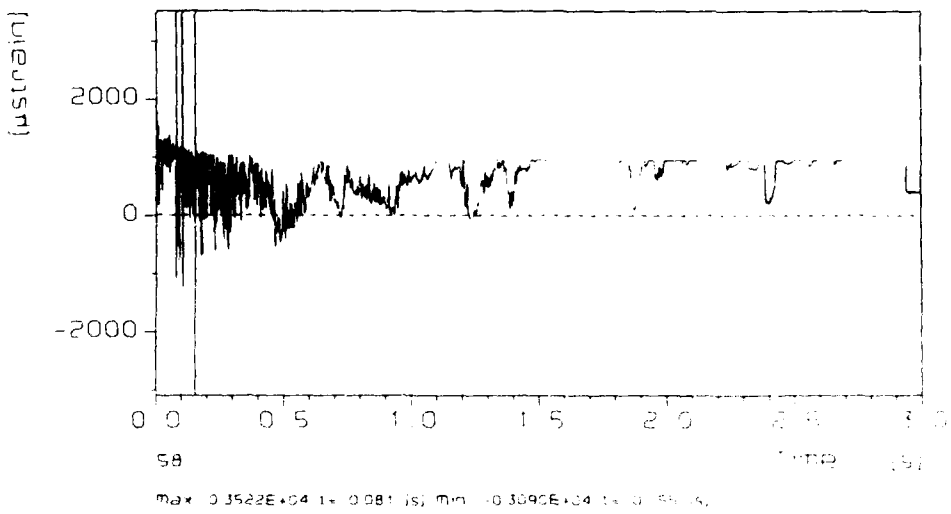
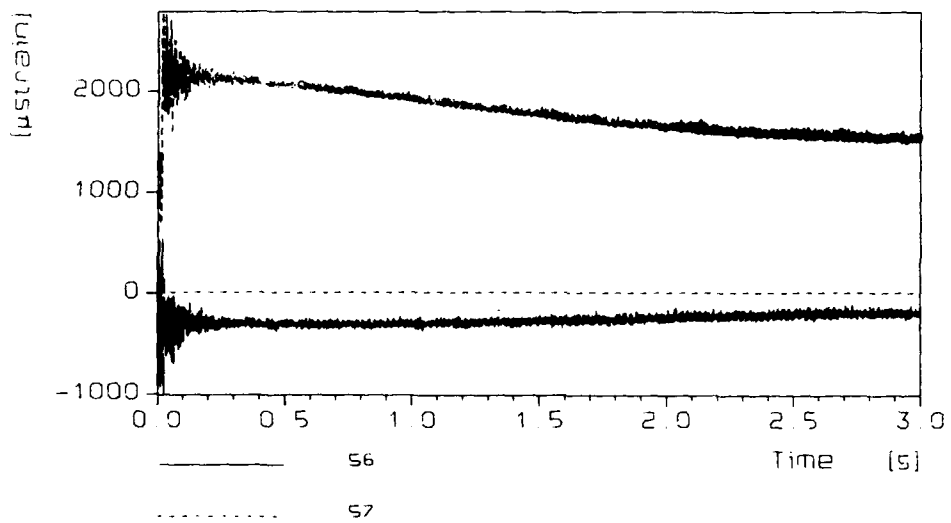
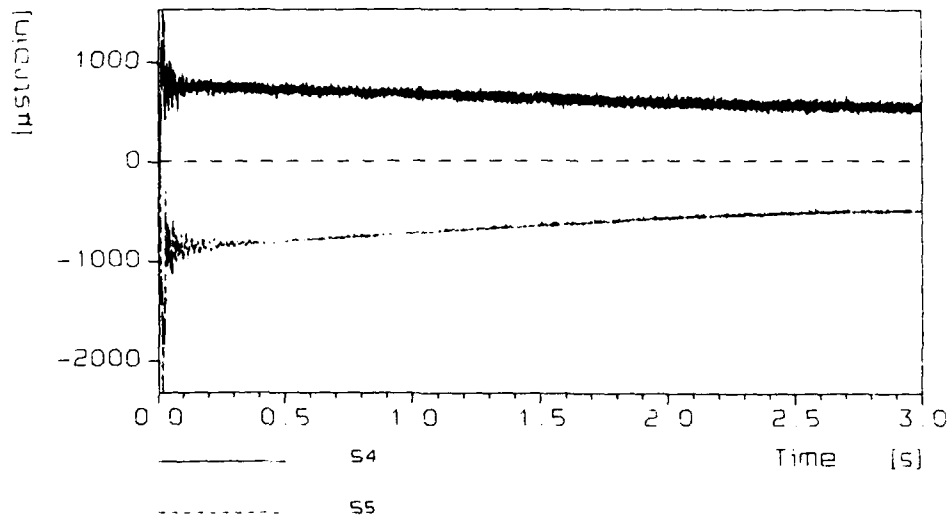

Figure 26 Strain gauge response S4 and S5, S6 and S7, S8 and S9 (BHD 23) - 3.0 s base

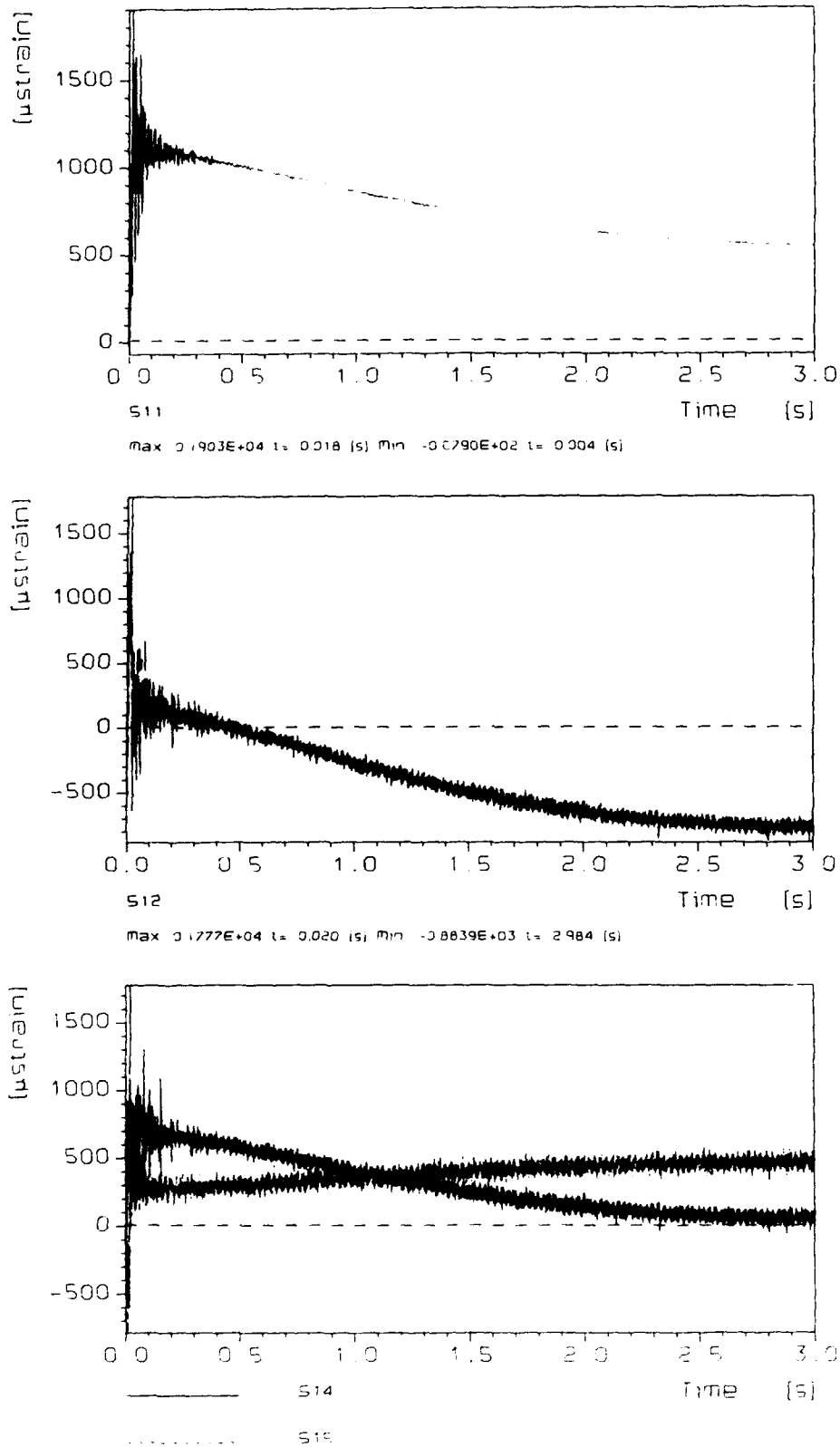

Figure 27 Strain gauge response S11, S12, S14 and S15 (BHD 23) (3.0 s base)

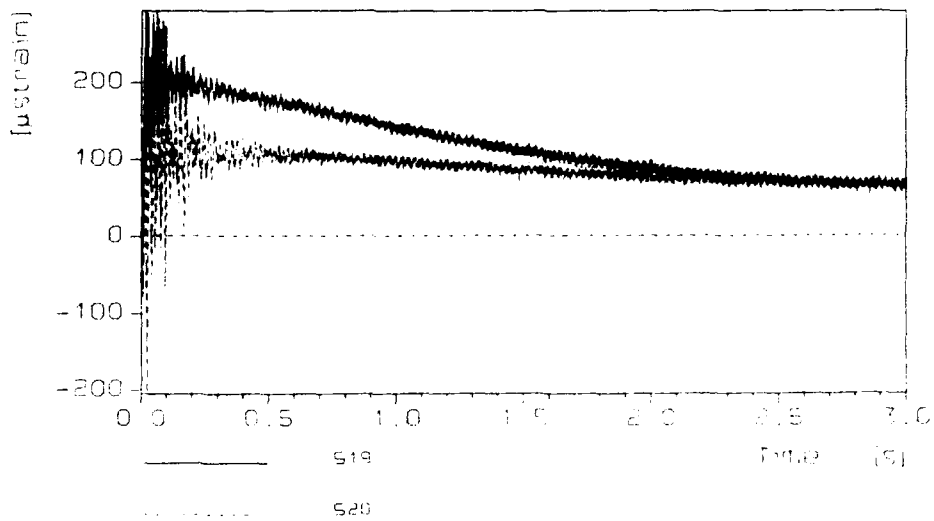
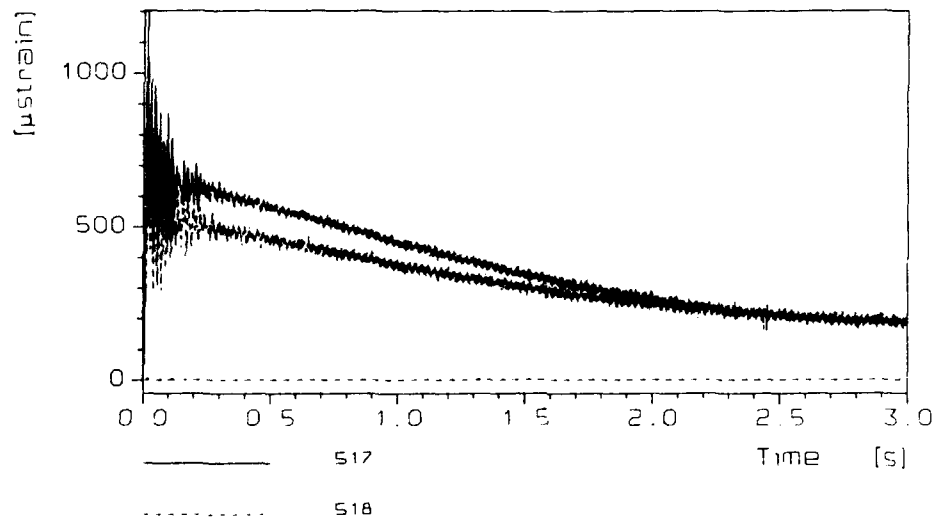
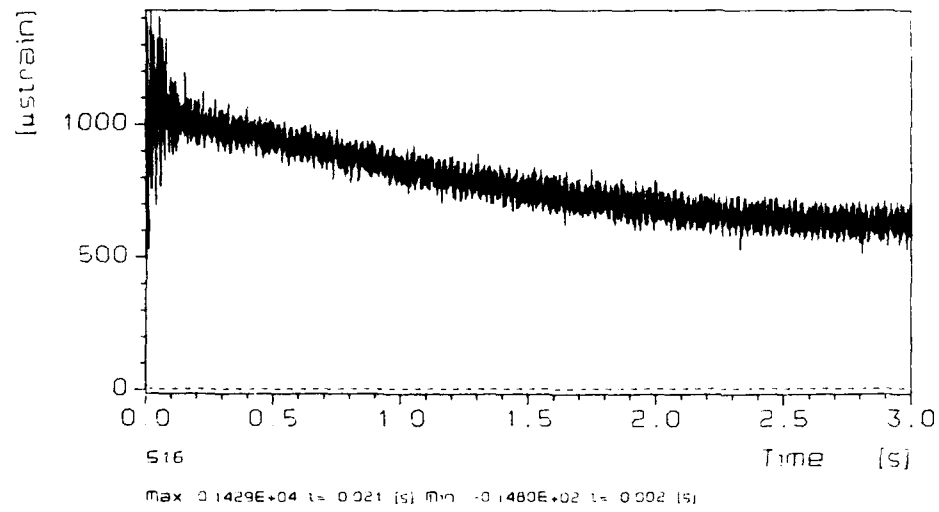

Figure 28 Strain gauge response S16, S17 and S18, S19 and S20 (BHD 23) (3.0 s base)

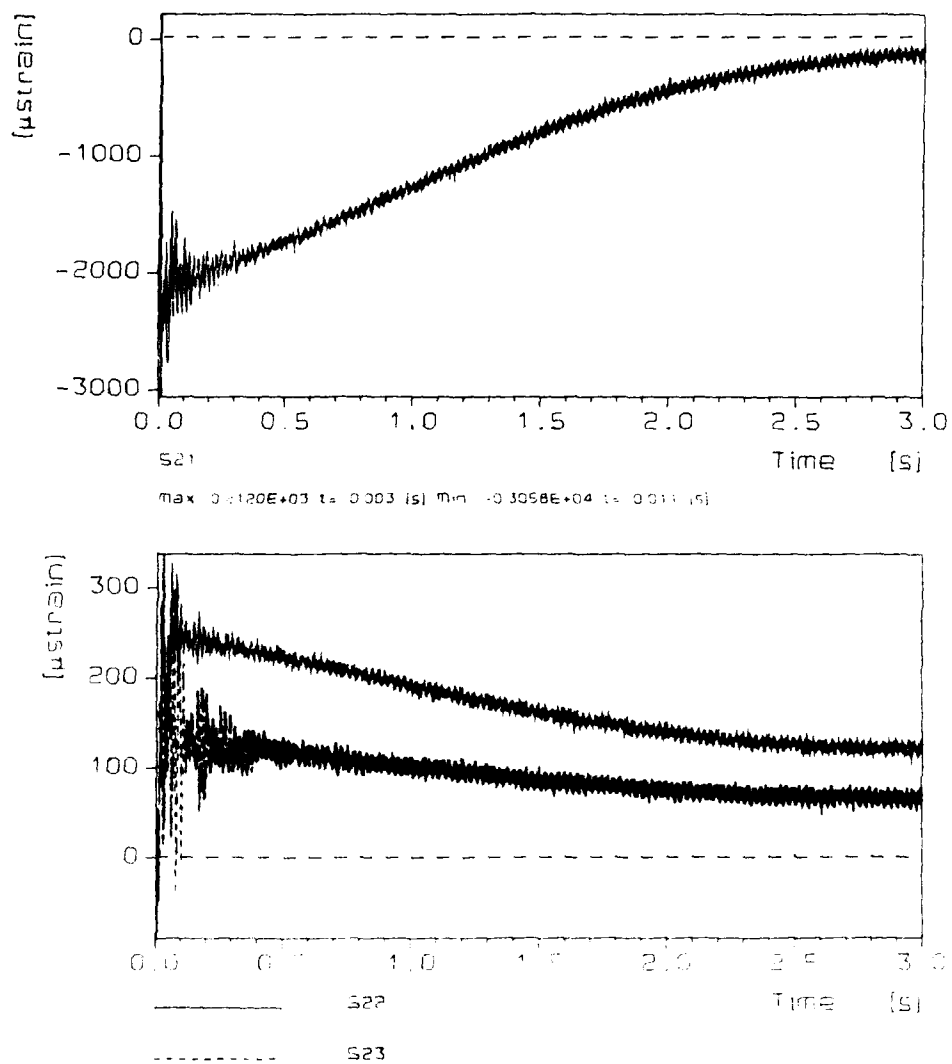

Figure 29 Strain gauge response S21, S22 and S23 (BHD 32) (3 s base)

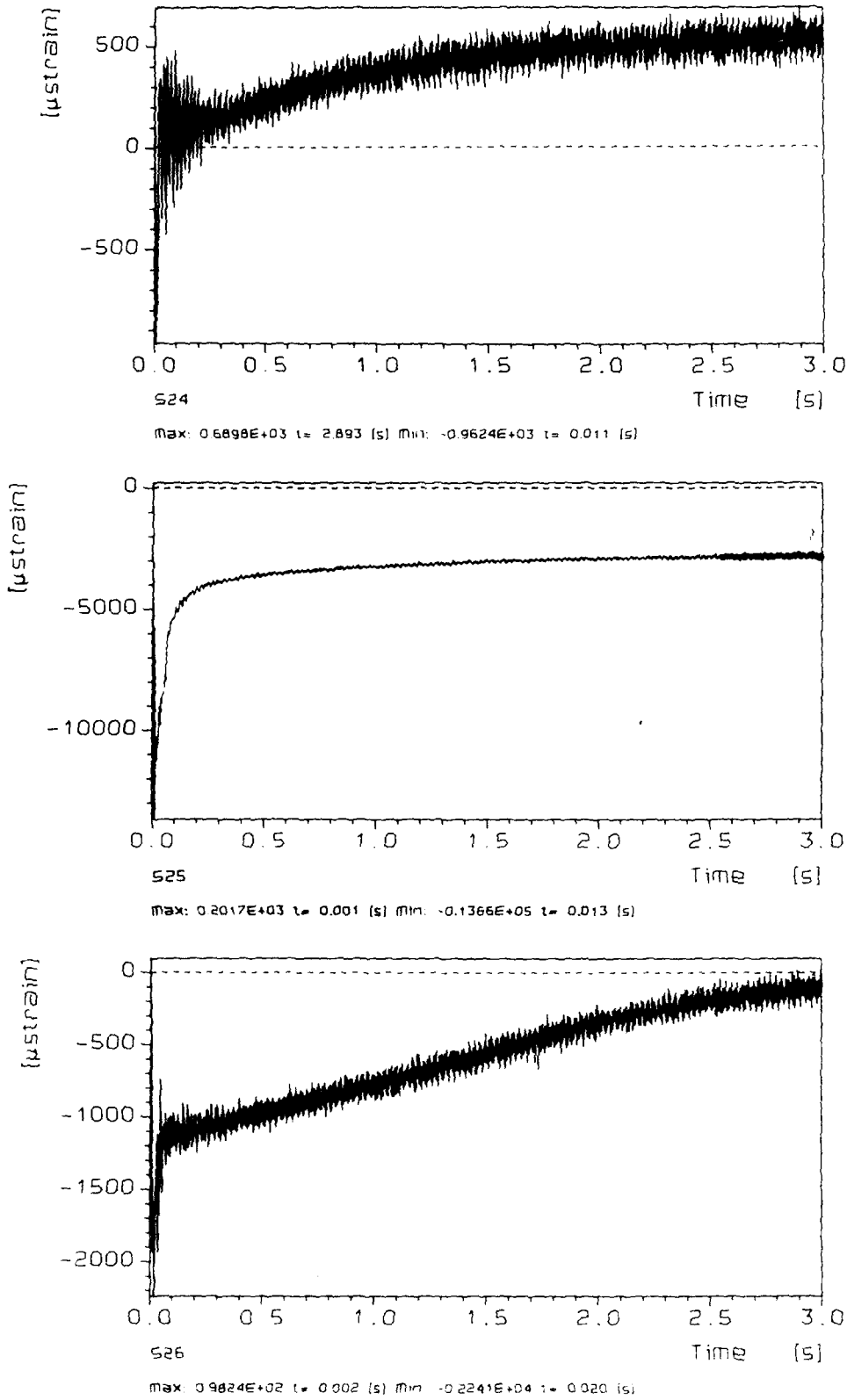

Figure 30 Strain gauge response S24, S25, S26 (floor officers' compartment) (3 s base)

6 ACCELERATION MEASUREMENT

6.1 Position of the accelerometers

During the experiment in the crew forward sleeping compartment, seven accelerometers were used, mounted on the H and J deck, respectively. The locations of the accelerometers are summarized in Table 10 and shown schematically in Figures 31, 32 and 33. In these figures the direction of sensitivity of the transducers is denoted by the length axis of the block ■.

Table 10 Position of the accelerometers

Device	Mounting position		
A5	ceiling	J-deck	74 cm BHD 45, on PS girder
A6	floor	J-deck	75 cm from BHD 45
A8	ceiling	J-deck	284 cm from BHD 23, on PS girder
A9	see A5	horizontal measuring direction	
A10	see A8	horizontal measuring direction	
A11	75 cm above floor,	60 cm from BB	
A13	119 cm above floor,	on stiffener near chartroom	

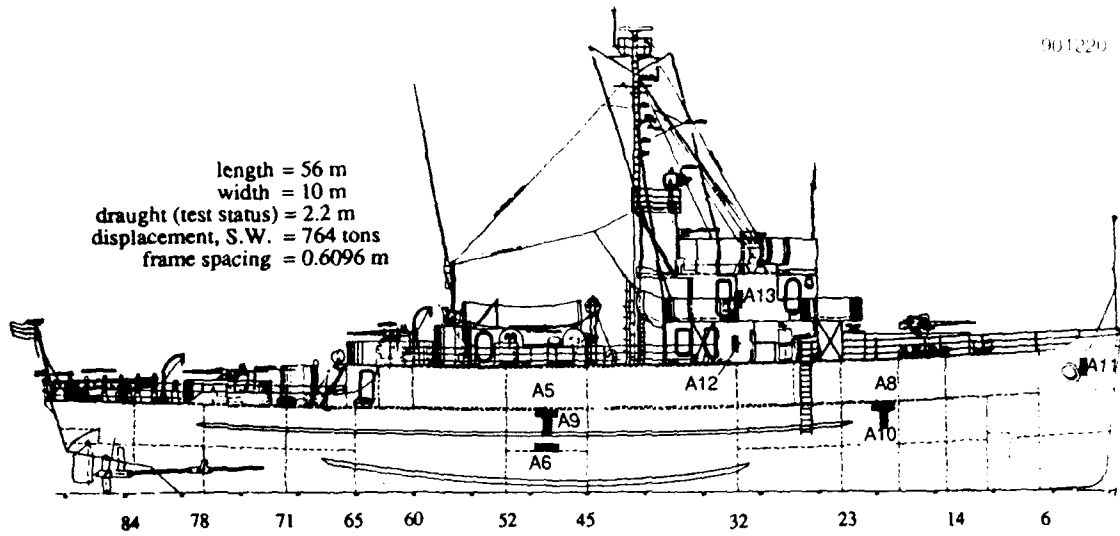

Figure 31 Schematic illustration of the accelerometers positions

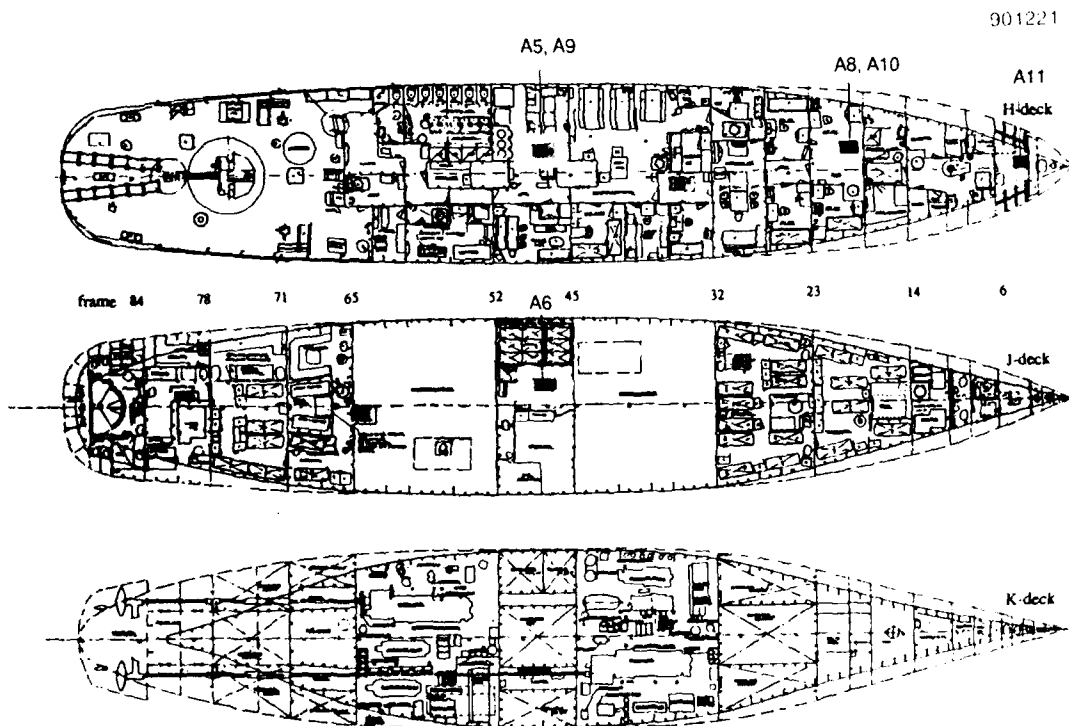

Figure 32 Schematic illustration of the accelerometer positions

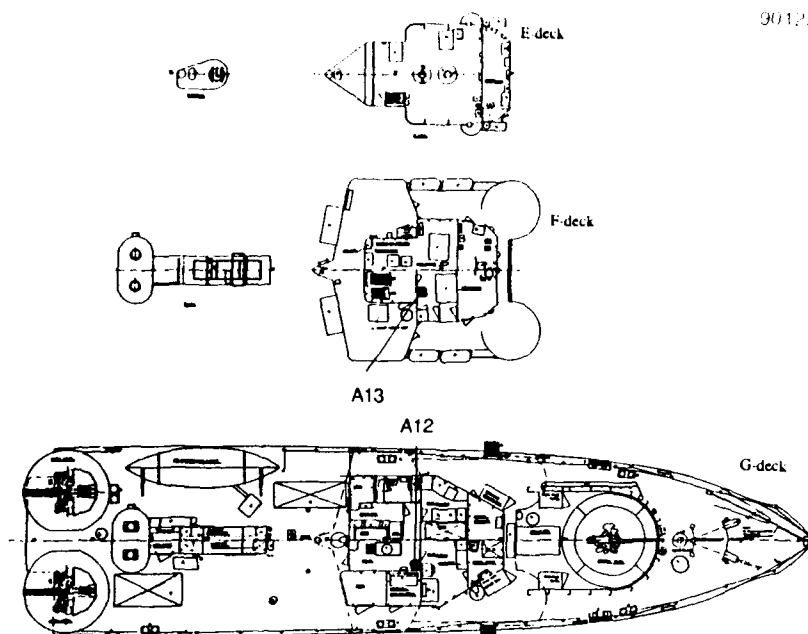

Figure 33 Schematic illustration of the accelerometer positions

6.2 Discussion of the acceleration measurements

The results of the acceleration measurements are shown in Figures 34-39. A distortion of the measurements was removed by a 50 Hz signal. A third order low pass Butterworth filter (1.5 kHz) was used to minimize the influence of the higher frequencies.

Integration of the acceleration recordings with respect to the time resulted in velocity and displacement signals. However, it must be noted that drift correction was applied to achieve 'reliable' displacement signals. The drift correction is indicated in the legends of the figures. Notwithstanding these corrections, drift is still noticeable in some of the displacement signals. It is obvious that the (rather ad hoc) digital signal analyses techniques applied influence the ultimate presented velocity and displacement signals.

The recorded responses of transducers A11 and A13 were disturbed with dropouts/spikes. It is for this reason that the integrations which would lead to velocity and displacement signals were omitted.

The shock spectra of these acceleration signals are shown in Figures 40-46. Damping was omitted, resulting in an identical positive and negative residual shock spectra.

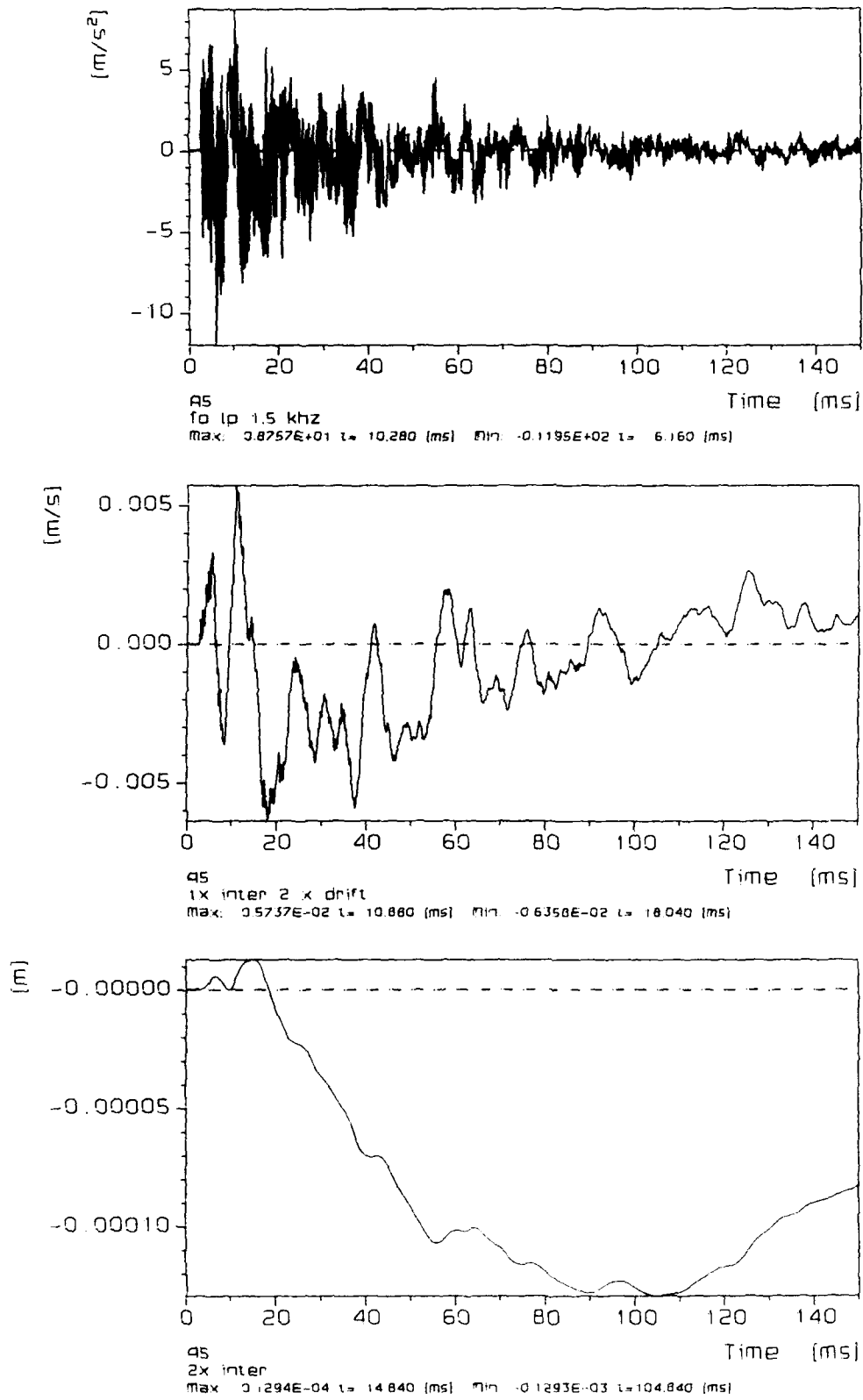

Figure 34 Accelerometer A5

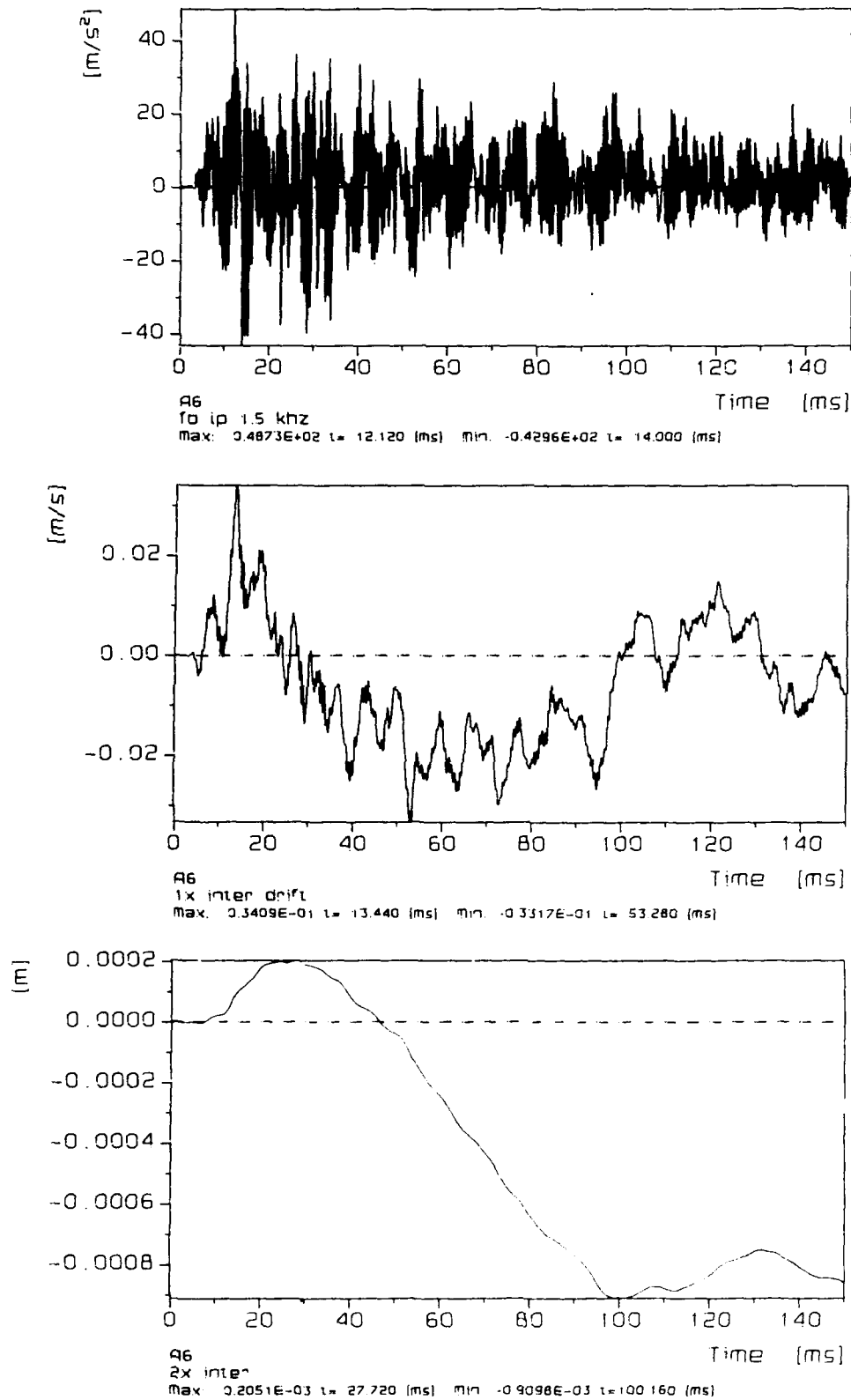

Figure 35 Accelerometer A6

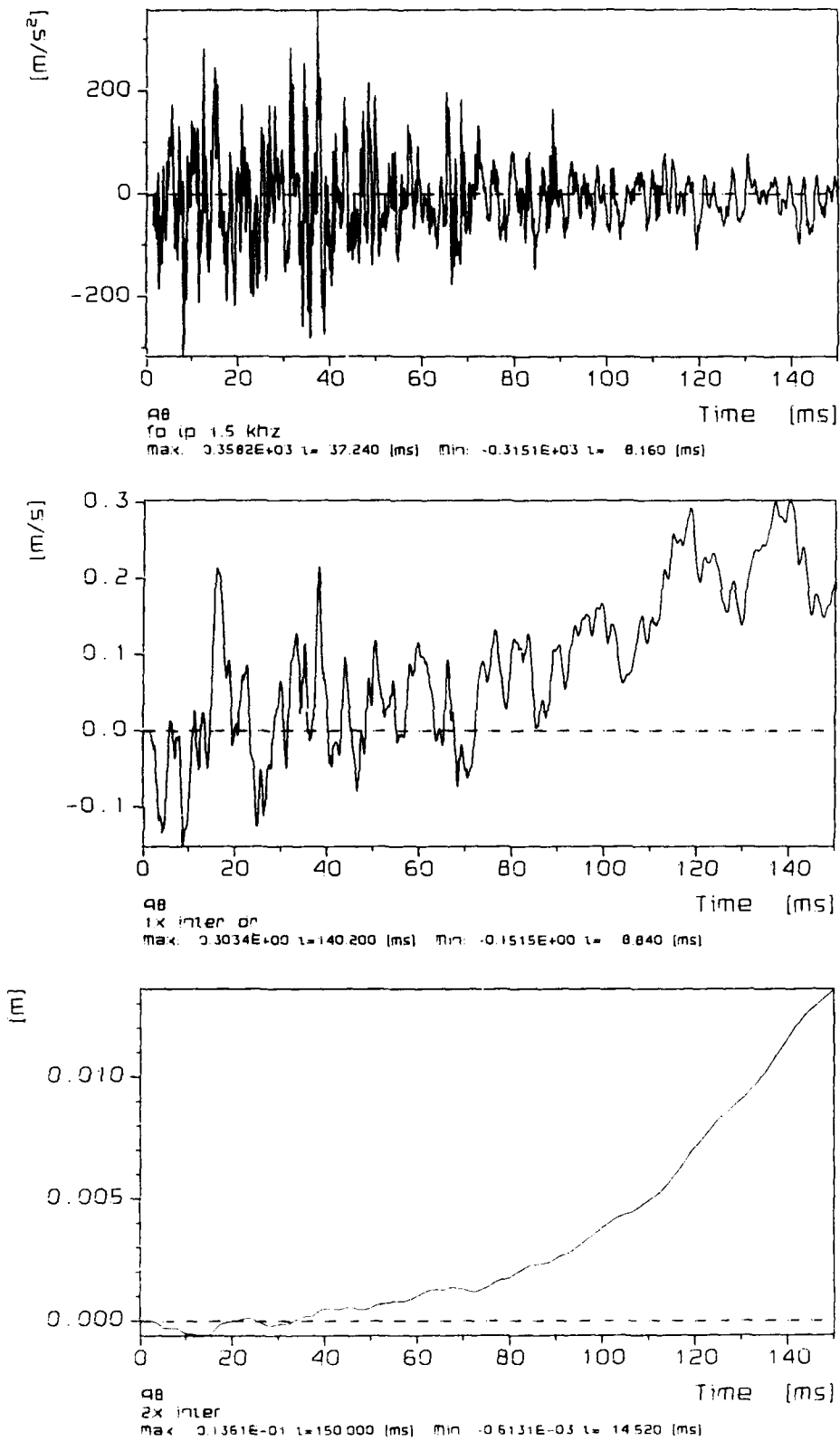

Figure 36 Accelerometer A8

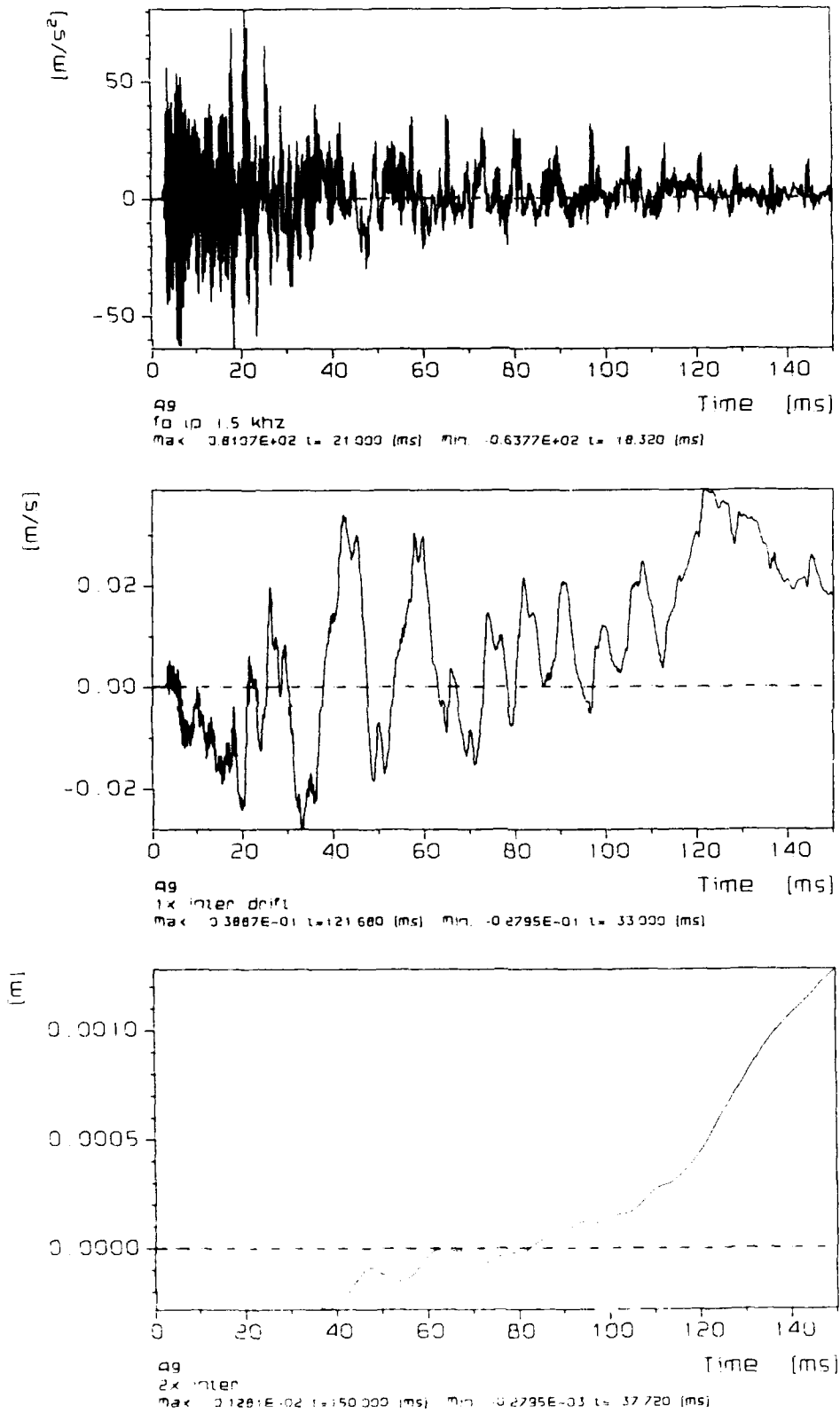

Figure 37 Accelerometer A9

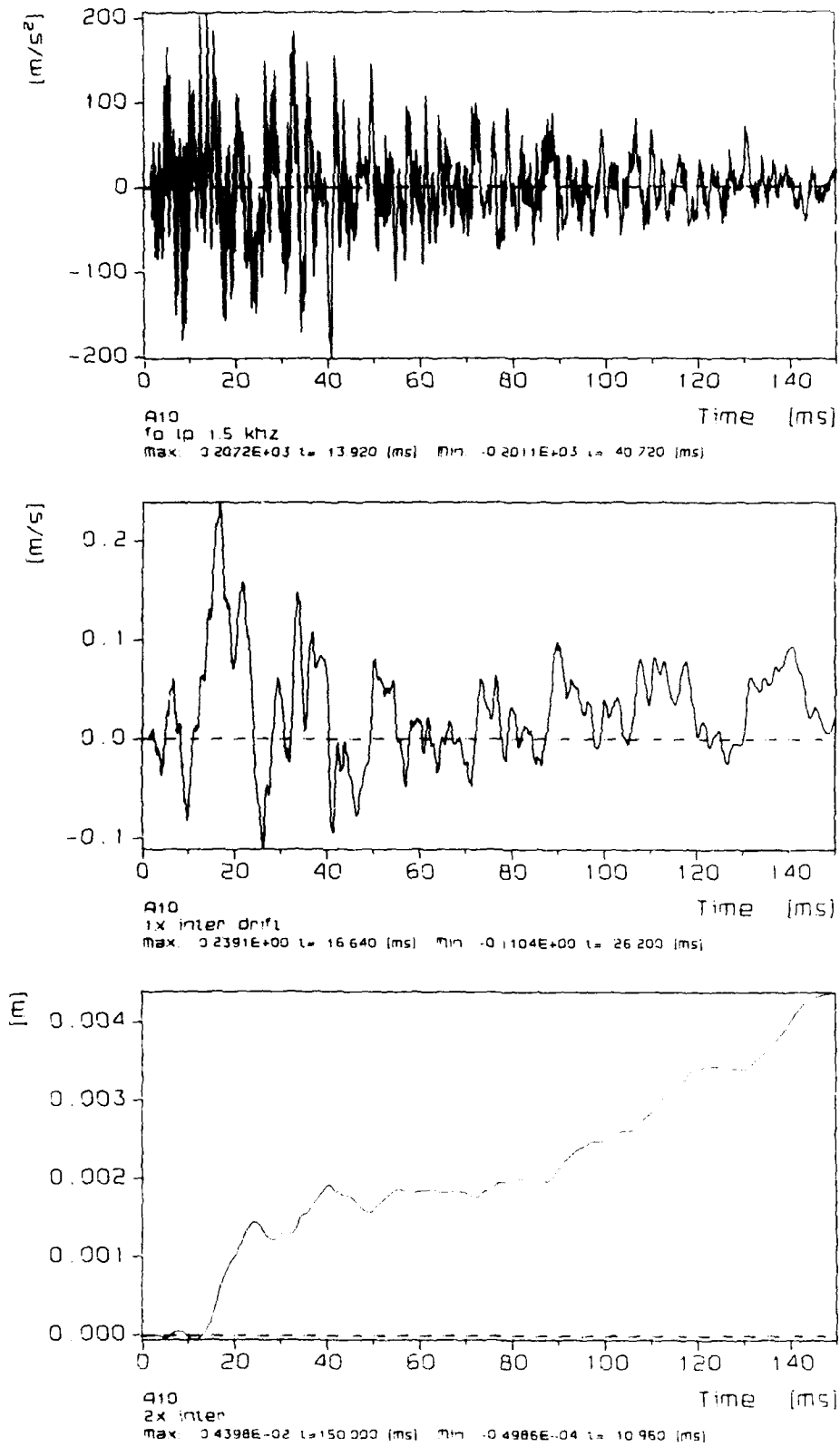

Figure 38 Accelerometer A10

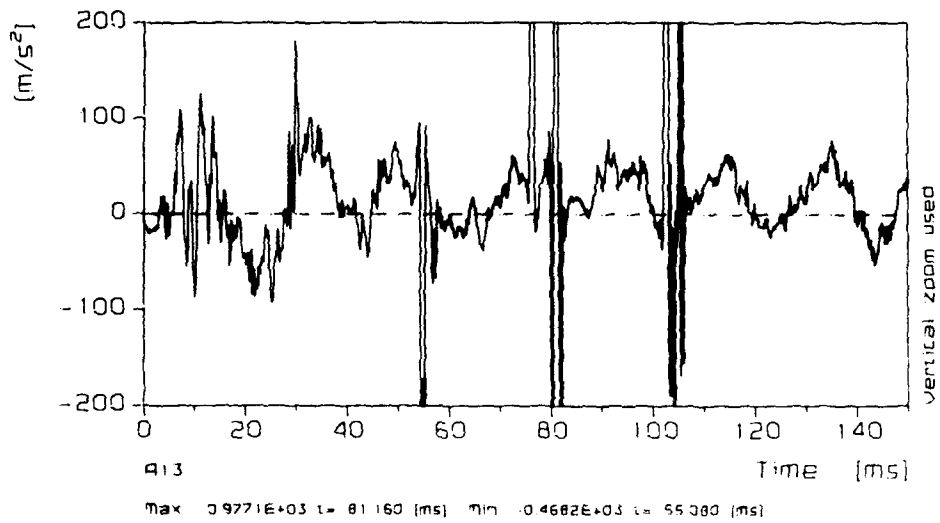
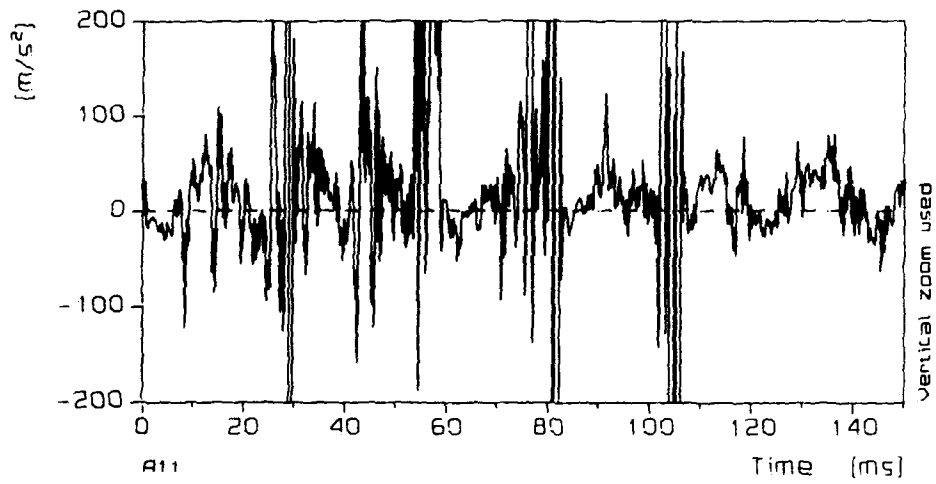

Figure 39 Accelerometer A11, A13

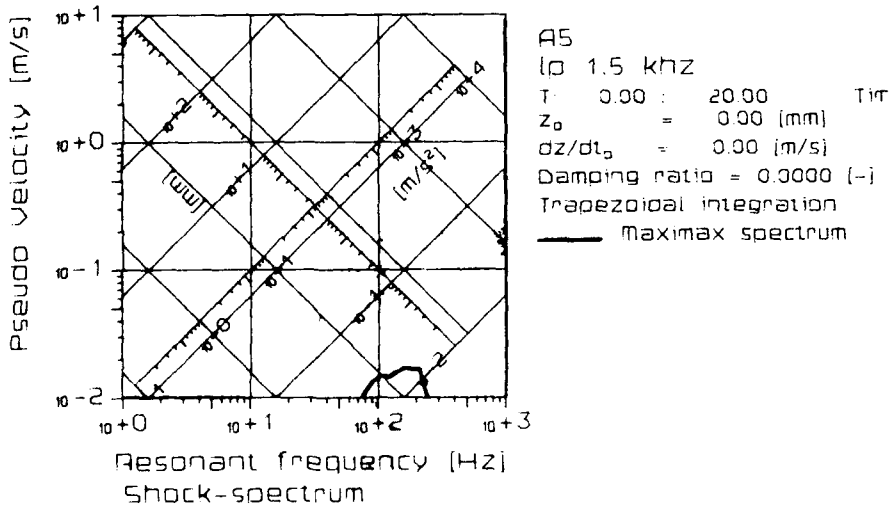
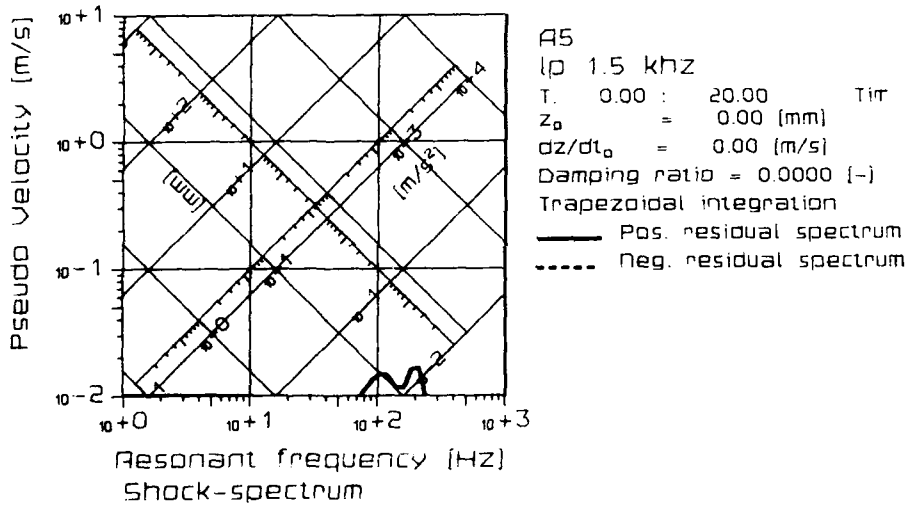
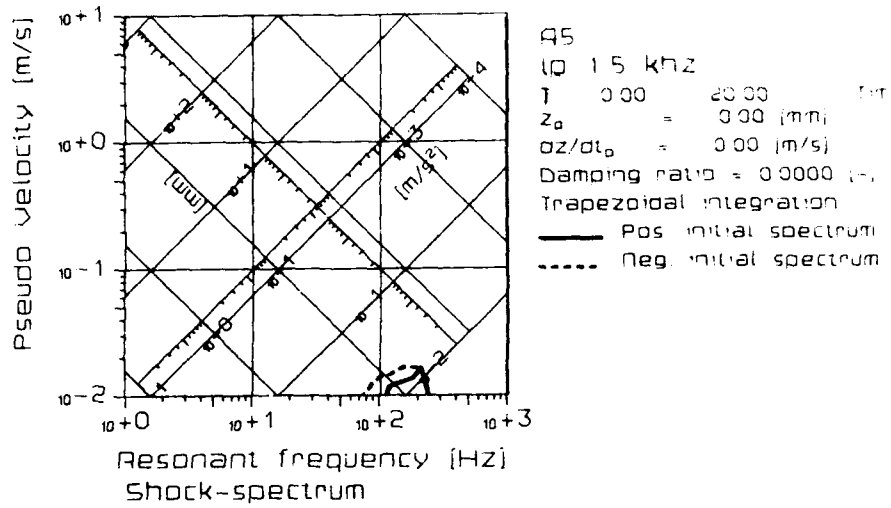
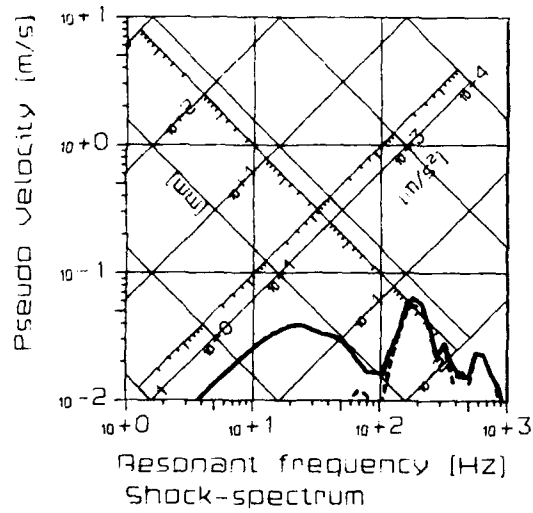
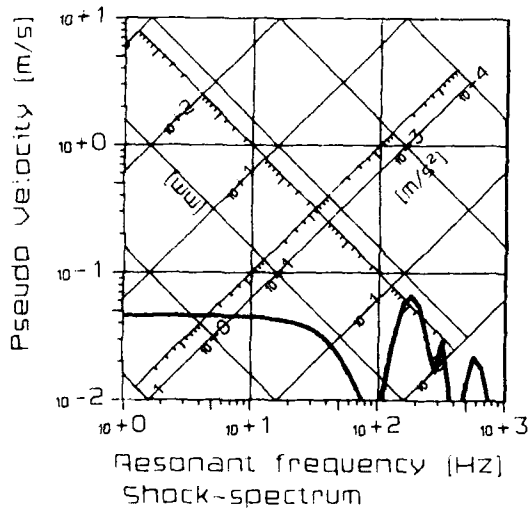

Figure 40 Shock spectra of accelerometer A5



A6
 l_p 1.5 kHz
 T: 0.00 : 20.00 Tir
 z₀ = 0.00 [mm]
 dz/dt₀ = 0.00 [m/s]
 Damping ratio = 0.0000 [-]
 Trapezoidal integration
 — Pos. initial spectrum
 - - - Neg. initial spectrum



A6
 l_p 1.5 kHz
 T: 0.00 : 20.00 Tir
 z₀ = 0.00 [mm]
 dz/dt₀ = 0.00 [m/s]
 Damping ratio = 0.0000 [-]
 Trapezoidal integration
 — Pos. residual spectrum
 - - - Neg. residual spectrum

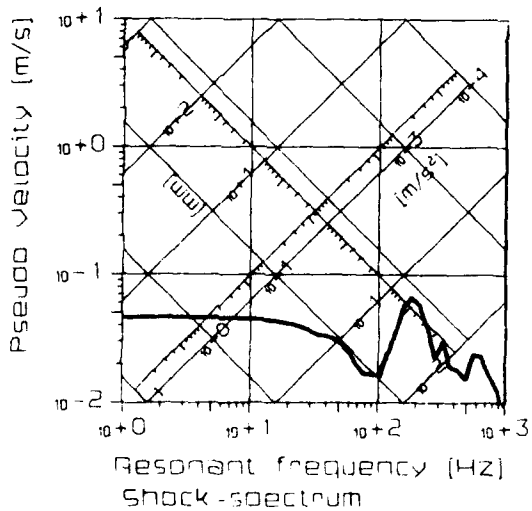

A6
 l_p 1.5 kHz
 T: 0.00 : 20.00 Tir
 z₀ = 0.00 [mm]
 dz/dt₀ = 0.00 [m/s]
 Damping ratio = 0.0000 [-]
 Trapezoidal integration
 — Maximax spectrum

Figure 41 Shock spectra of accelerometer A6

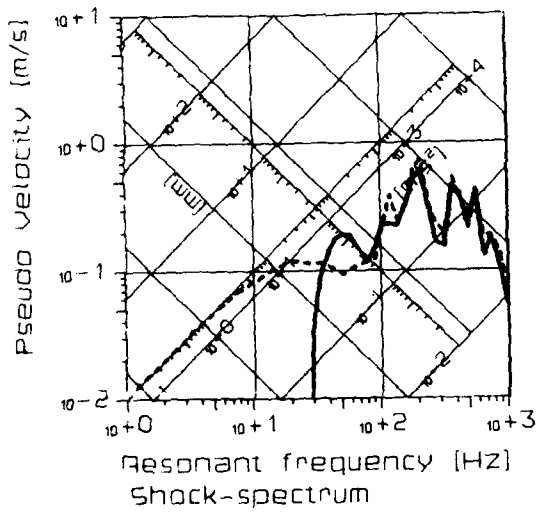

A8
 lg 1.5 khz
 T: 0.00 : 20.00 TIT
 $Z_0 = 0.00$ (mm)
 $dz/dt_0 = 0.00$ (m/s)
 Damping ratio = 0.0000 (-)
 Trapezoidal integration
 — Pos. initial spectrum
 - - - Neg. initial spectrum

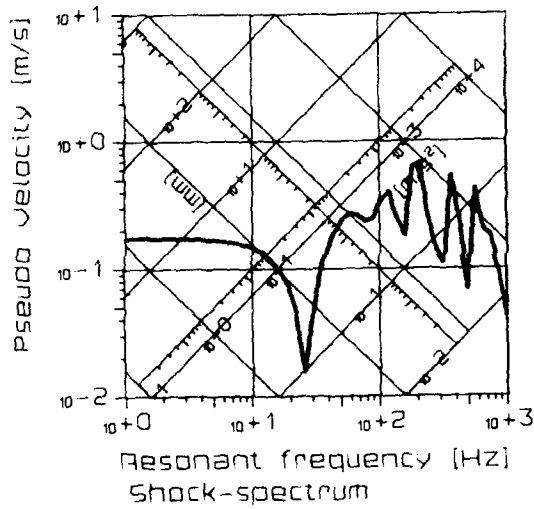

A8
 lg 1.5 khz
 T: 0.00 : 20.00 TIT
 $Z_0 = 0.00$ (mm)
 $dz/dt_0 = 0.00$ (m/s)
 Damping ratio = 0.0000 (-)
 Trapezoidal integration
 — Pos. residual spectrum
 - - - Neg. residual spectrum

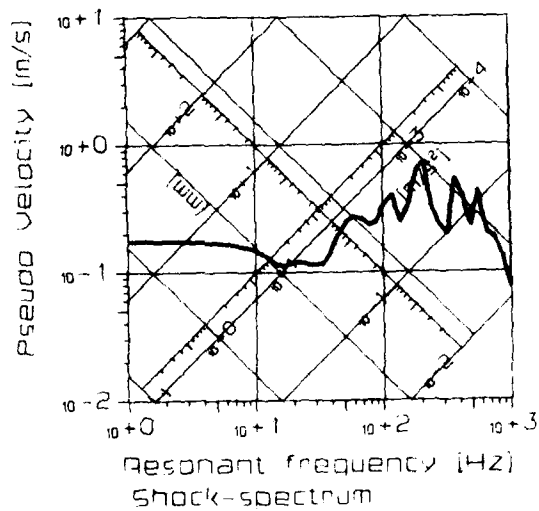

A8
 lg 1.5 khz
 T: 0.00 : 20.00 TIT
 $Z_0 = 0.00$ (mm)
 $dz/dt_0 = 0.00$ (m/s)
 Damping ratio = 0.0000 (-)
 Trapezoidal integration
 — Maximax spectrum

Figure 42 Shock spectra of accelerometer A8

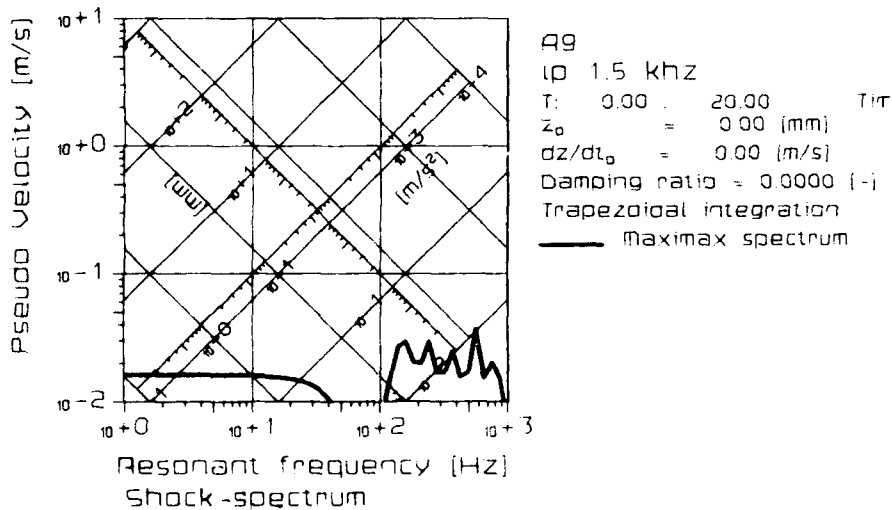
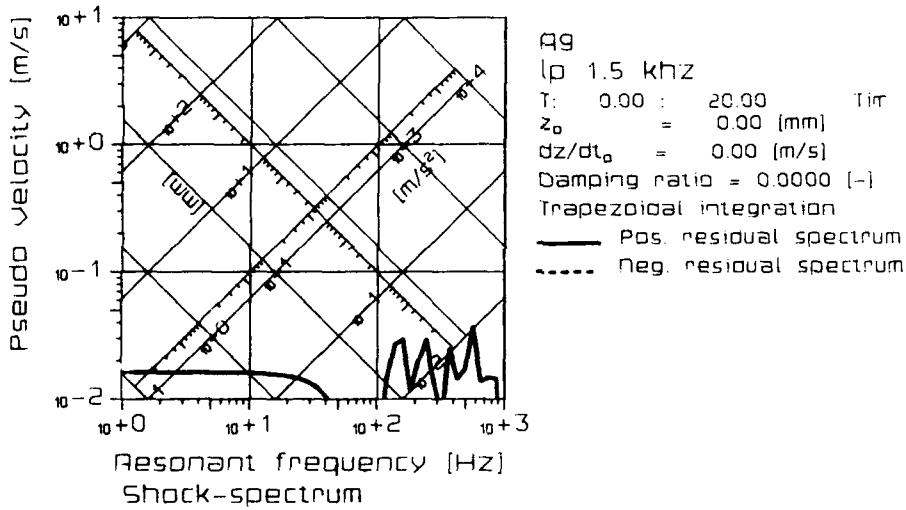
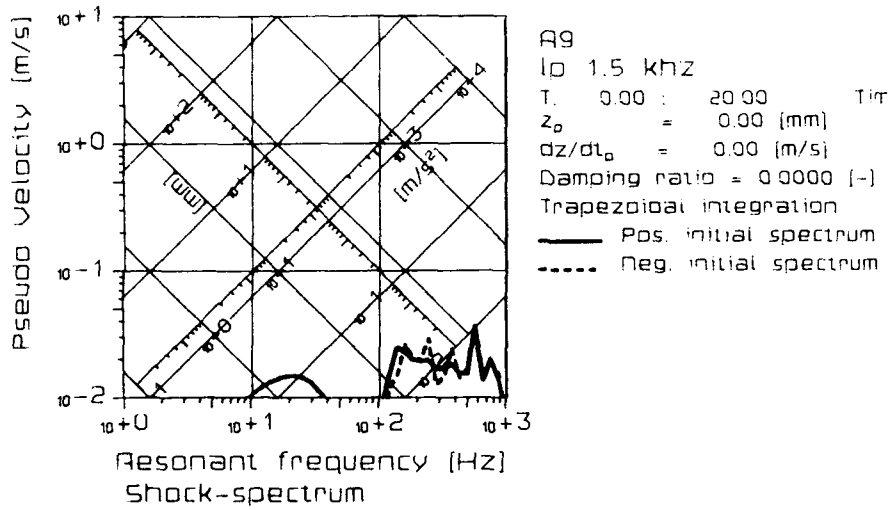

Figure 43 Shock spectra of accelerometer A9

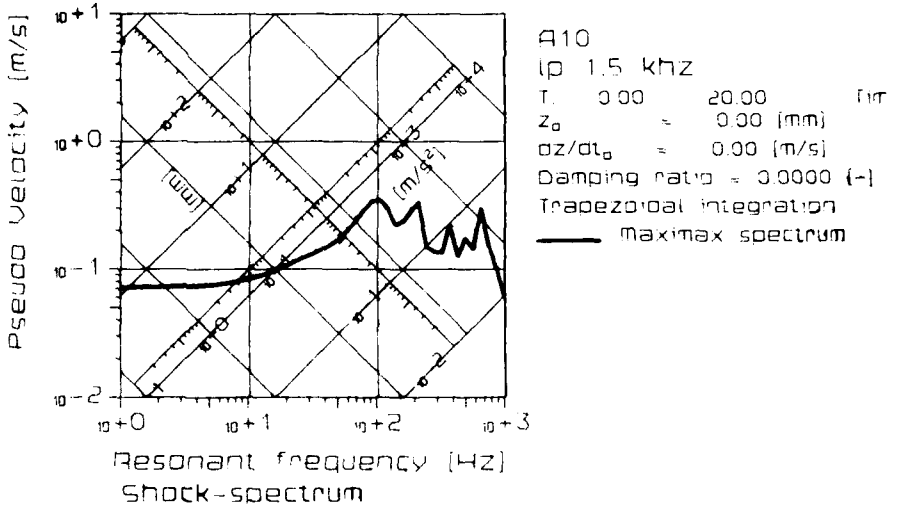
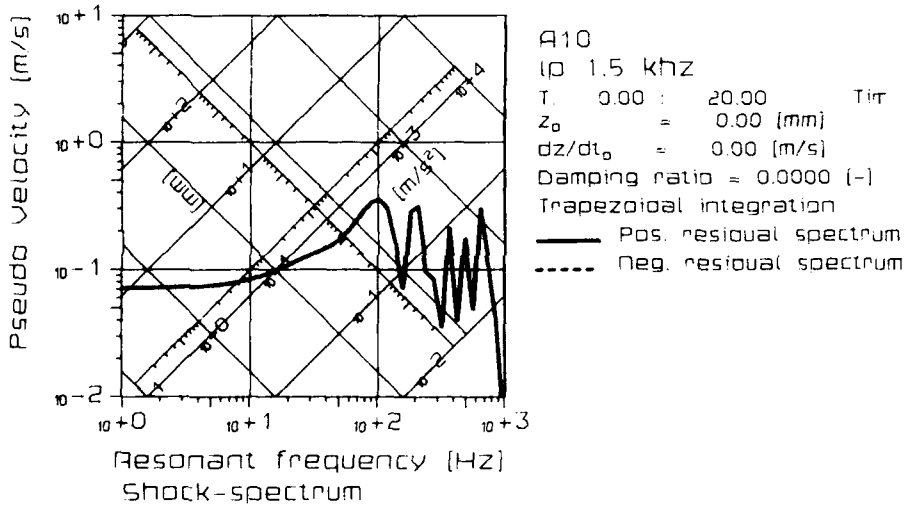
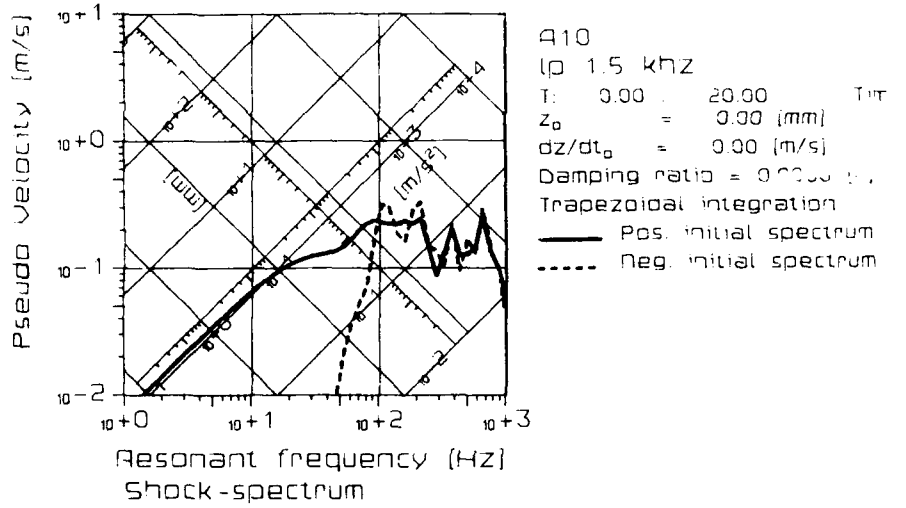

Figure 44 Shock spectra of accelerometer A10

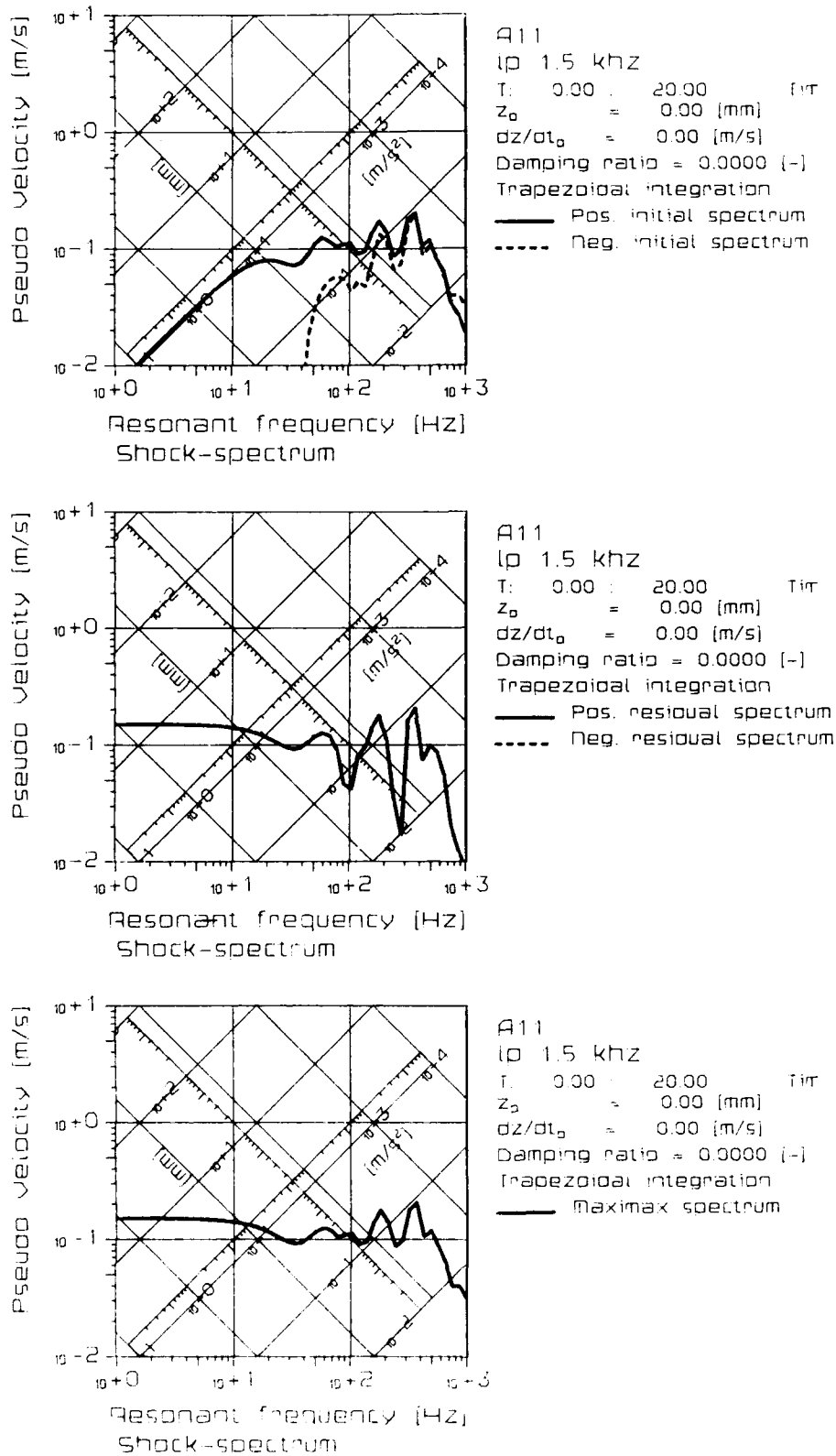

Figure 45 Shock spectra of accelerometer A11

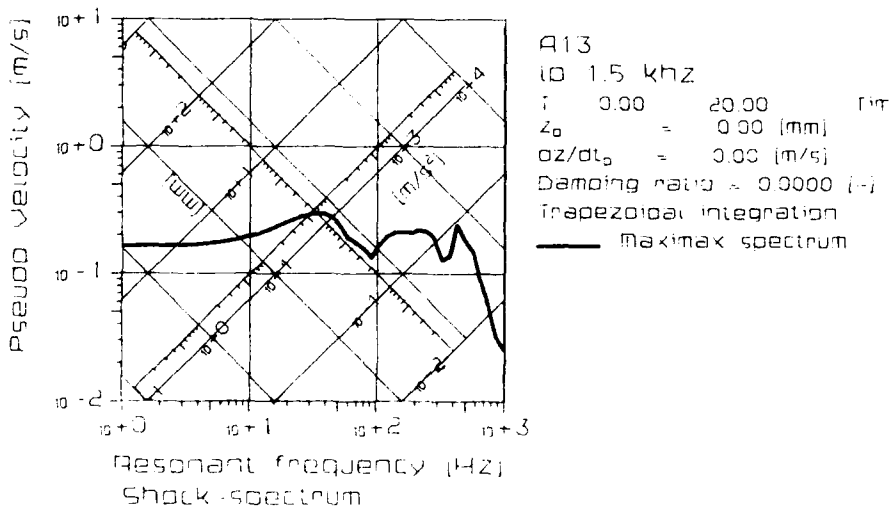
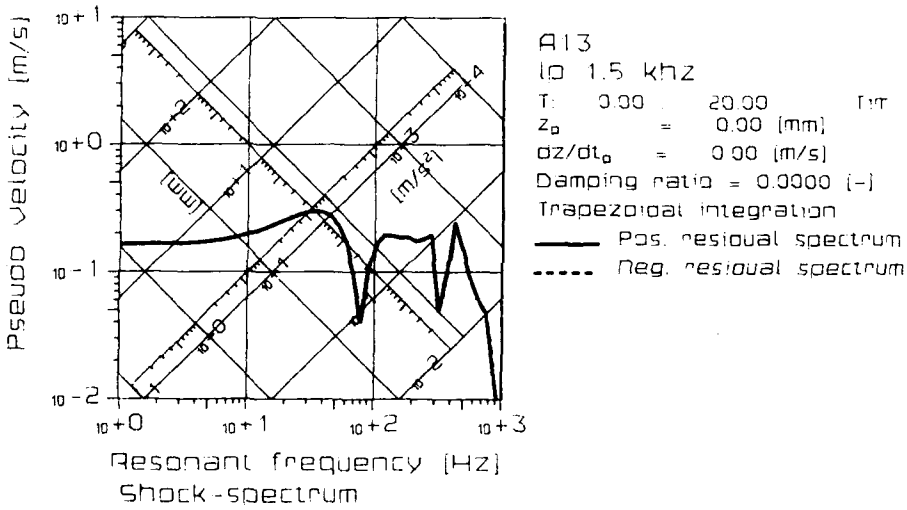
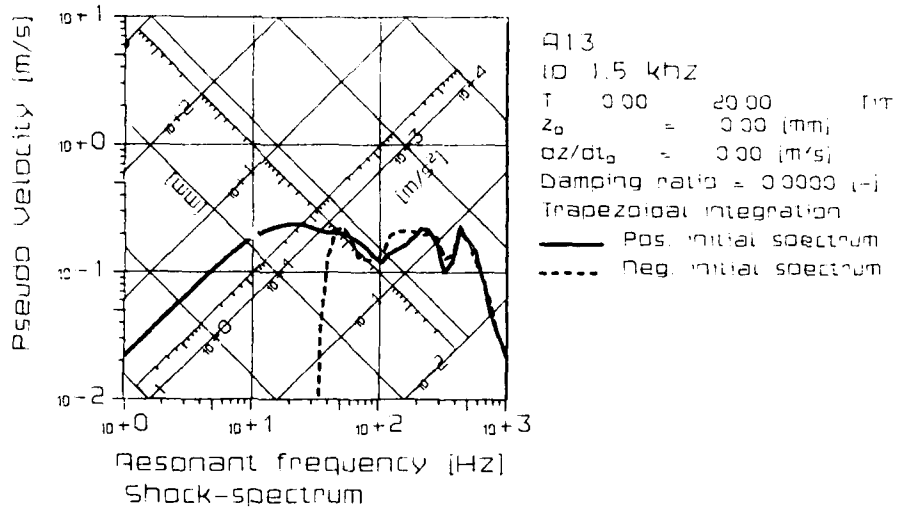

Figure 46 Shock spectra of accelerometer A13

7 TEMPERATURE MEASUREMENT

7.1 Position of the temperature transducers

During the experiment, one temperature measurement was performed. The location of the temperature measurement is given in Table 11 and shown schematically in Figure 47.

Table 11 Position of the temperature transducer

Device	Height	Position
T1	113 cm	115 cm from BHD 14 in ASDIC room in the vicinity of Q5

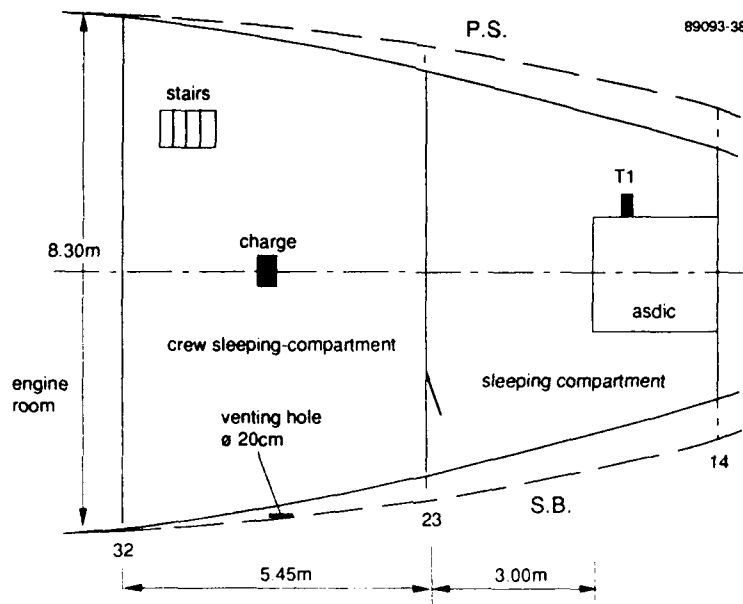

Figure 47 Schematic illustration of the temperature transducer position

7.2 Discussion of the temperature measurement

Unfortunately, due to the temperature transducer malfunction no temperature signal can be shown.

8 BREAKWIRES

8.1 Position of the breakwires

To enable the determination of the possible moment of collapse of the watertight door in BHD 23, two breakwires (BW1 and BW2) were used. They were mounted behind the watertight door at one-third and two-thirds of the way up the door, outside the experiment compartment.

The positions of the breakwires used are shown schematically in Figure 48.

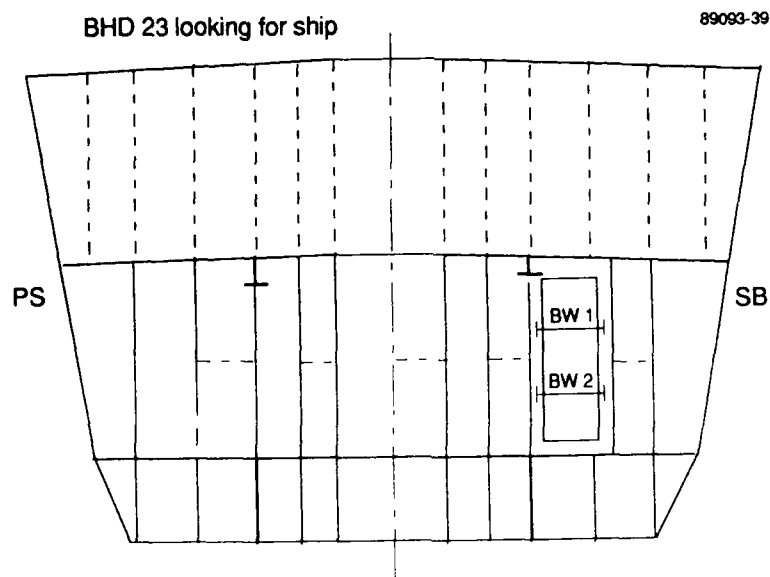

Figure 48 Schematic illustration of the breakwire positions in BHD 23

8.2 Discussion of the breakwire measurements

In Figure 49, the registered signals are shown. Note that the door did not collapse during this experiment.

From these signals, an initial response time of 2.8 (or 3.8) ms is found for BW1, while BW2 starts responding after 4 ms. These times stem from the possible arrival time of the shock wave at the door (see for instance strain gauge S3 (3.1 ms), and the symmetrically placed blast transducers B4 (3.8 ms) and B5 (5.8 ms)). From this it can be concluded that the breakwires registered the shock front's arrival time at the door, but this time is not the intended collapse time of the door. This suggests that the combination of breakwires/microswitches used were too sensitive to shock.

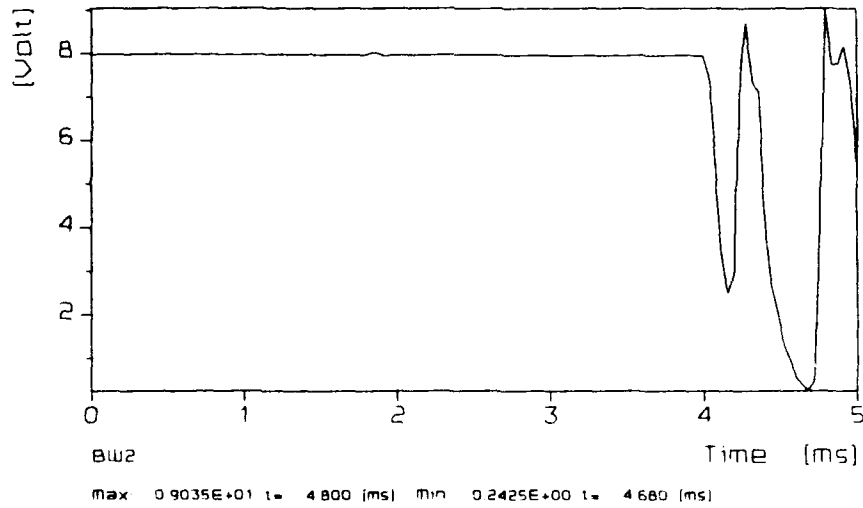
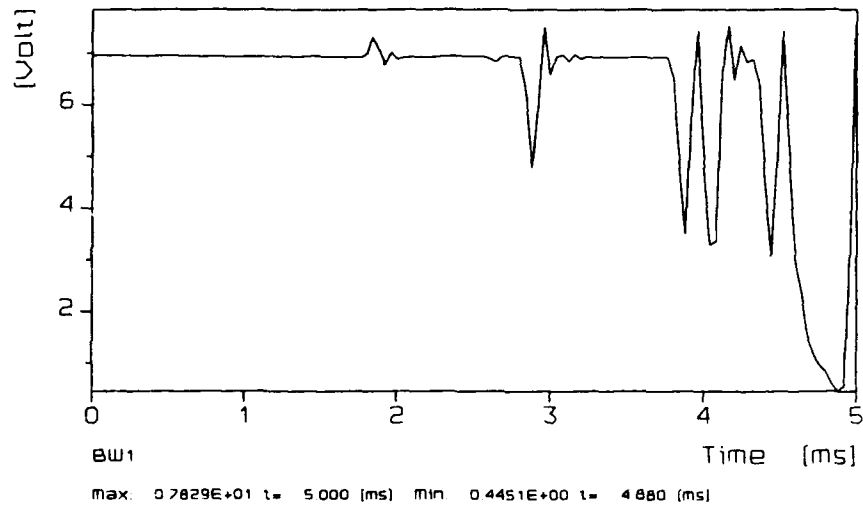

Figure 49 The breakwire signals

9 CONCLUSION

During the Wolf Phase II trial, a number of instrumented experiments in the crew forward and the crew aft sleeping compartment took place. During the instrumented experiments, attention was paid to the blast, quasi-static pressure, strain, acceleration, temperature and the possible moment of collapse of the watertight door(s).

This report deals with the bare 3 kg TNT experiment in the crew forward sleeping compartment. The interpretation of the recordings will be the subject of the van Erkel (1992) reports.

The setting of the recording equipment was based on the prediction of the 12 kg TNT experiment which was performed later that day. This effects the signal-to-noise ratio of the recordings of this particular experiment.

The blast measurements in the experiment compartment seem to be very realistic. An acceptable correspondence is found for the theoretically predicted peak pressures and arrival times which were based on a centrally ignited, spherical charge.

The quasi-static pressure measurements in the experiment compartment compare well with the theoretical predictions. The recordings of the quasi-static pressure in adjacent compartments contained no relevant information and was probably due to a small leakage. It is for this reason that these signals were omitted from this report.

Opposite-mounted strain gauges were presented in one figure to enable a better understanding of the physical phenomena.

Some of the recordings are omitted from this report due to malfunction. Most recordings show elastic deformations, although some recordings indicate a (permanent) elasto-plastic deformation. Drift, due to temperature, is noticeable in some of the recordings. Some couples of glued strain gauges show an 'in-phase' behaviour whereas other couples show an 'anti-phase' response behaviour. This indicates longitudinal and transversal waves.

A distortion of 50 Hz was removed from the acceleration measurements. Filtering was performed with a third order low pass Butterworth filter (1.5 kHz) to diminish the influence of the higher frequencies.

Integration of the acceleration signals resulted in velocity and displacement signals. Drift becomes apparent in some of the displacement signals. Two of the acceleration measurements were afflicted with serious distortions, it is for this reason that no velocity or displacement signals (A11 and A13) are incorporated in this report.

The reported velocity and displacement signals should be handled with care due to the rather ad hoc applied digital signal techniques. The undamped shock spectra are included in this report.

The temperature measurement failed during this experiment.

The watertight door did not collapse during this experiment. The registered breakwire responses must have been due to the sensitivity of the breakwire/microswitch combination to shock. Registered response times seem to correspond with the shock front's arrival time at the door.

From this it can be concluded that the 3 kg TNT experiment in the crew forward sleeping compartment resulted in a valuable set of reliable data, which can be used for the validation of computational prediction methods.

10 AUTHENTICATION

The realization of the Wolf Phase II trials presented in this set of reports was achieved due to the effort of a number of technicians from the Explosion Prevention Group: Mr. M.W.L. Dirkse, Mr. Ph. van Dongen, Mr. R.M. van de Kastele and Mr. A.M. Steenweg who carried out the experiments and processed the recordings.

We would also like to acknowledge the supporting services of the Royal Netherlands Navy.

Date:

10 April 1934

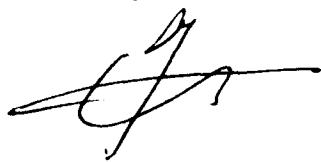

J. Weerheijm
(Project Manager)

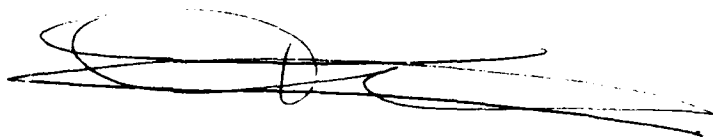

Th.L.A. Verhagen
(Author)

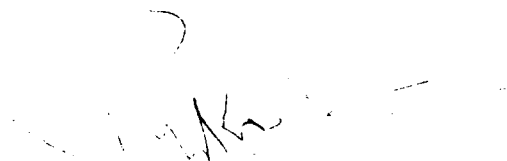

R.M. van de Kastele
(Author)

11 REFERENCES

11.1 General references

Baker, W.E.; Cox, P.A.; Westine, P.S.; Kulesz, J.J.; Strehlow, R.A.
Explosion hazards and evaluation fundamental studies in engineering 5
Elsevier Scientific Publishing Company, 1983

11.2 FRET reports

Kastele, R.M. van de; Verhagen, Th.L.A.
Geïnstrumenteerde beproeving van het roefdierfregat "FRET"
Meetresultaten van de proef in het manschappen slaapverblijf op het voorschip
PML - TNO, Rapport No. 1989-32 (in Dutch)

Kastele, R.M. van de; Verhagen, Th.L.A.
Geïnstrumenteerde beproeving van het roefdierfregat "FRET"
Meetresultaten van de proef in het manschappen slaapverblijf op het achterschip
PML - TNO, Rapport No. 1989-33 (in Dutch)

Kastele, R.M. van de; Verhagen, Th.L.A.
Geïnstrumenteerde beproeving van het roefdierfregat "FRET"
Achtergrond informatie met betrekking tot gebruikte opnemers en bevestigingsmethoden
PML - TNO, Rapport No. 1989-34 (in Dutch)

11.3 WOLF, phase I reports

Kastele, R.M. van de; Zwaneveld, J.H.C.
Geïnstrumenteerde beproeving aan boord van fregat "WOLF"
Wolf I: Meetresultaten van de proeven in kabelgat/ankerlierruimte en onderofficiers verblijf/kombuis
PML - TNO, Rapport No. 1989-45 (in Dutch)

Kastele, R.M. van de; Zwaneveld, J.H.C.

Geïstrumenteerde beproeving aan boord van fregat "WOLF"

Wolf I: Resultaten van de metingen verricht in de stuurhut en de wasplaats

PML - TNO, Rapport No. 1990-12 (in Dutch)

Kastele, R.M. van de

Geïstrumenteerde beproeving aan boord van fregat "WOLF"

Wolf I: Achtergrond informatie met betrekking tot gebruikte opnemers en bevestigingsmethoden

PML - TNO, Rapport No. 1989-36 (in Dutch)

Zwaneveld, J.H.C.

Overpressure, blast, strain and accelerations in a ship compartment due to near external explosions

PML - TNO, Report No. 1989-18

11.4 WOLF, phase II reports

Verhagen, Th.L.A.; Kastele, R.M. van de

Instrumented experiments aboard the frigate "WOLF"

Wolf II: Measurement results of the 2 kg TNT experiment in the crew aft sleeping compartment

PML - TNO, 1992-10

Verhagen, Th.L.A.; Kastele, R.M. van de

Instrumented experiments aboard the frigate "WOLF"

Wolf II: Measurement results of the 3 kg TNT experiment in the crew front sleeping compartment

PML - TNO, 1992-11

Verhagen, Th.L.A.; Kastele, R.M. van de

Instrumented experiments aboard the frigate "WOLF"

Wolf II: Measurement results of the 5.5 kg TNT experiment in the crew aft sleeping compartment

PML - TNO, 1992-12

Verhagen, Th.L.A.; Kastele, R.M. van de

Instrumented experiments aboard the frigate "WOLF"

Wolf II: Measurement results of the 12 kg TNT experiment in the crew front sleeping compartment

PML - TNO, 1992-13

Verhagen, Th.L.A.; Kastele, R.M. van de
Instrumented experiments aboard the frigate "WOLF"
Wolf II: Measurement results of the 15 kg TNT experiment in the crew aft sleeping compartment
PML - TNO, 1992-14

Kastele, R.M. van de; Verhagen, Th.L.A.
Instrumented experiments aboard the frigate "WOLF"
Wolf II: Background information concerning the transducers and mounting methods used
PML - TNO, 1992-15

11.5 Roofdier Blast damage reports

Erkel, A.G. van
Blast tests on ship doors
PML-TNO, 1990-31

Erkel, A.G. van
Roofdier internal blast damage
Part I: Bare charge experiments in the aft sleeping compartment
PML-TNO, 1992-(to be published)

Erkel, A.G. van
Roofdier internal blast damage
Part II: Bare charge experiments in the front sleeping compartment
PML-TNO, 1992-(to be published)

Erkel, A.G. van
Roofdier internal blast damage
Part III: Experiments with shells and asymmetrical located bare charges
PML-TNO, 1992-(to be published)

Erkel, A.G. van
Roofdier internal blast damage
Part IV: lessons learned
PML-TNO, 1992-(to be published)

REPORT DOCUMENTATION PAGE

(MOD NL)

1. DEFENSE REPORT NUMBER (MOD-NL) TD94-2528	2. RECIPIENT'S ACCESSION NUMBER	3. PERFORMING ORGANIZATION REPORT NUMBER PML1992-11
4. PROJECT/TASK/WORKUNIT NO. 292489093	5. CONTRACT NUMBER A88/KM/419	6. REPORT DATE August 1992
7. NUMBER OF PAGES 66	8. NUMBER OF REFERENCES 19	9. TYPE OF REPORT AND DATES COVERED Final

10. TITLE AND SUBTITLE

Instrumented experiments aboard the frigate "WOLF". Wolf II: Measurement results of the 3 kg TNT experiment in the crew aft sleeping compartment.
(Gefinstrumenteerde beproevingen aan boord van het fregat "WOLF". Wolf II: Meetresultaten van de 3 kg TNT beproeving van het manschappen slaapcompartiment op het achterschip.)

11. AUTHOR(S)

Th.L.A. Verhagen,
R.M. van de Kastele

12. PERFORMING ORGANIZATION NAME(S) AND ADDRESS(ES)

TNO Prins Maurits Laboratory
P.O. Box 45, 2280 AA Rijswijk, The Netherlands

13. SPONSORING AGENCY NAME(S) AND ADDRESS(ES)

DMKM
P.O. Box 20702, 2500 ES The Hague

14. SUPPLEMENTARY NOTES

15. ABSTRACT (MAXIMUM 200 WORDS (1044 BYTE))

Within the framework of the research into the vulnerability of ships, an experimental investigation took place in 1989 aboard the frigate "WOLF" of the "Roofdierklasse" (PCE 1604 class) (Wolf, Phase II).
In this report recordings of an instrumented experiment in the crew aft sleeping compartment are presented.
During this experiment, a non-fragmenting charge of 3 kg TNT was initiated.

16. DESCRIPTORS

Frigates
Vulnerability
TNT
Explosion Effects
Blast Measurement

IDENTIFIERS

Pressure Measurement
Strain Measurement
Accelerometers
Temperature Measurement

17A. SECURITY CLASSIFICATION (OF REPORT) UNCLASSIFIED	17B. SECURITY CLASSIFICATION (OF PAGE) UNCLASSIFIED	17C. SECURITY CLASSIFICATION (OF ABSTRACT) UNCLASSIFIED
18. DISTRIBUTION AVAILABILITY STATEMENT Unlimited Distribution		17D. SECURITY CLASSIFICATION (OF TITLES) UNCLASSIFIED

DISTRIBUTION LIST

- 1 DWOO
- 2 HWO-KL
- 3 HWO-KLu
- 4 HWO-KM
- 5/7 TDCK
- 8/11 Ministerie van Defensie
DMKM, Afd. Scheepsbouw
- 12 Hoofddirecteur DO-TNO
- 13 Lid Instituuts Advies Raad PML
Prof. drs. P.J. van den Berg
- 14 Lid Instituuts Advies Raad PML
Prof. Ir. M.A.W. Scheffelaar
- 15 Lid Instituuts Advies Raad PML
Prof. Ir. H. Wittenberg
- 16 PML-TNO, Directeur Programma; daarna reserve
- 17/21 PML-TNO, Secretariaat Divisie 2, Groep Explosiepreventie en -bescherming
- 22/24 PML-TNO, Secretariaat Divisie 3, Groep Wapeneffectiviteit
- 25 PML-TNO, Documentatie
- 26 PML-TNO, Archief