

**AD-A256 541**

AD-A256 541

**TNO-Defensieonderzoek**

Prins Maurits Laboratorium TNO

TD 91-2527

①

TNO-rapport  
PML 1992-13

August 1992  
Copy no.: 5

Instrumented experiments aboard the frigate "WOLF".  
Wolf II: Measurement results of the 12 kg TNT  
experiment in the crew front sleeping  
compartment

**TDCK RAPPORTENCENTRALE**  
Frederikkazerne, gebouw 140  
v/d Burchlaan 31 MPC 16A  
TEL. : 070-3166394/6395  
FAX. : (31) 070-3166202  
Postbus 90701  
2509 LS Den Haag 

**DTIC**  
ELECTE  
OCT 29 1992

**S E D**

**DISTRIBUTION STATEMENT**

Approved for public release  
Distribution Unlimited



TNO-rapport  
PML 1992-13

Instrumented experiments aboard the frigate "WOLF".  
Wolf II: Measurement results of the 12 kg TNT  
experiment in the crew front sleeping  
compartment

August 1992  
Copy no.: - 5

Author (s):

Th.L.A. Verhagen  
R.M. van de Kastele

Total Number of Pages :  
(ex. distr. list and RDP)  
68

Number of Annexes :  
-

Number of Figures :  
50

Number of Tables :  
11

DO assignment no.:  
A88/KM/419

Number of Copies :  
26

Classification  
Report :  
UNCLASSIFIED

Title:  
UNCLASSIFIED

Summary:  
UNCLASSIFIED

Annex(es) :  
-

Alle rechten voorbehouden.  
Niets uit deze uitgave mag worden  
vermenigvuldigd en/of openbaar gemaakt  
door middel van druk, fotokopie, microfilm  
of op welke andere wijze dan ook, zonder  
voorafgaande toestemming van TNO.

Indien dit rapport in opdracht werd  
uitgebracht, wordt voor de rechten en  
verplichtingen van opdrachtgever en  
opdrachtnemer verwezen naar de  
'Algemene Voorwaarden voor Onderzoeks-  
opdrachten aan TNO', dan wel de  
betreffende terzake tussen partijen  
gesloten overeenkomst.  
Het ter inzage geven van het TNO-rapport  
aan direct belanghebbenden is toegestaan.

TNO

DTIC  
ELECTE  
OCT 29 1992  
S E D

DISTRIBUTION STATEMENT  
Approved for public release  
Distribution Unlimited

92-28363



## Summary

Within the framework of the research into the vulnerability of ships, an experimental investigation took place in 1989 aboard the frigate "WOLF" of the "Roofdierklasse" (PCE 1604 class) (Wolf, Phase II).

In this report the recordings of an instrumented experiment in the crew front sleeping compartment are presented. During this experiment, a non-fragmenting charge of 12 kg TNT was initiated.

## Samenvatting

In het kader van het onderzoek naar de kwetsbaarheid van schepen zijn in 1989 een aantal experimenten uitgevoerd op het fregat "WOLF" van de Roofdierklasse (PCE 1604 class) (Wolf, Fase II).

In dit rapport worden de meetresultaten gepresenteerd van een geïnstrumenteerde beproeving van het manschappen slaapcompartiment op het voorschip. Tijdens dit experiment werd een kale, 12 kg TNT, lading tot ontploffing gebracht.



Accession For	
NTIS CRA&I	<input checked="" type="checkbox"/>
DTIC TAB	<input type="checkbox"/>
Unannounced	<input type="checkbox"/>
Justification .....	
By .....	
Distribution /	
Availability Codes	
Dist	Avail and/or Special
A-1	

## CONTENTS

	SUMMARY/SAMENVATTING	2
	CONTENTS	3
1	INTRODUCTION	5
2	DESCRIPTION OF THE EXPERIMENT	7
2.1	Objective of the experiments	7
2.2	Experimental set-up	7
3	PRESSURE MEASUREMENT	10
3.1	Position of the pressure transducers	10
3.2	Discussion of the pressure measurements	12
4	QUASI-STATIC PRESSURE MEASUREMENT	18
4.1	Position of the quasi-static pressure transducers	18
4.2	Discussion of the quasi-static pressure measurement	20
5	STRAIN MEASUREMENT	26
5.1	Position of the strain gauges	26
5.2	Discussion of the strain measurements	31
6	ACCELERATION MEASUREMENTS	42
6.1	Position of the accelerometers	42
6.2	Discussion of the acceleration measurement	45
7	TEMPERATURE MEASUREMENTS	60
7.1	Position of the temperature transducers	60
7.2	Discussion of the temperature measurement	61

8	BREAKWIRES	61
8.1	Position of the breakwires	61
8.2	Discussion of the breakwire measurement	62
9	CONCLUSION	63
10	AUTHENTICATION	65
11	REFERENCES	66
11.1	General references	66
11.2	FRET reports	66
11.3	WOLF, phase I reports	67
11.4	WOLF, phase II reports	67
11.5	Roofdier Blast damage reports	68

## 1 INTRODUCTION

In order to obtain quantitative as well as qualitative information on the effects of internal and external explosions on a frigate, a number of (instrumented) experiments were performed on the frigates "FRET" and "WOLF" (Figure 1). These are Roofdier class frigates, the former United States Navy PCE 1604 class, which were decommissioned by the Royal Netherlands Navy. A general overview of the Roofdier trials is given in Table 1.

Table 1 A general overview of the Roofdier trials

Fret I	June/September 1987	(v.d. Kastele and Verhagen, 1989)
Wolf I	October/ November 1988	(v.d. Kastele and Zwaneveld, 1989)
Wolf II	September/October 1989	(Verhagen and v.d. Kastele, 1992)

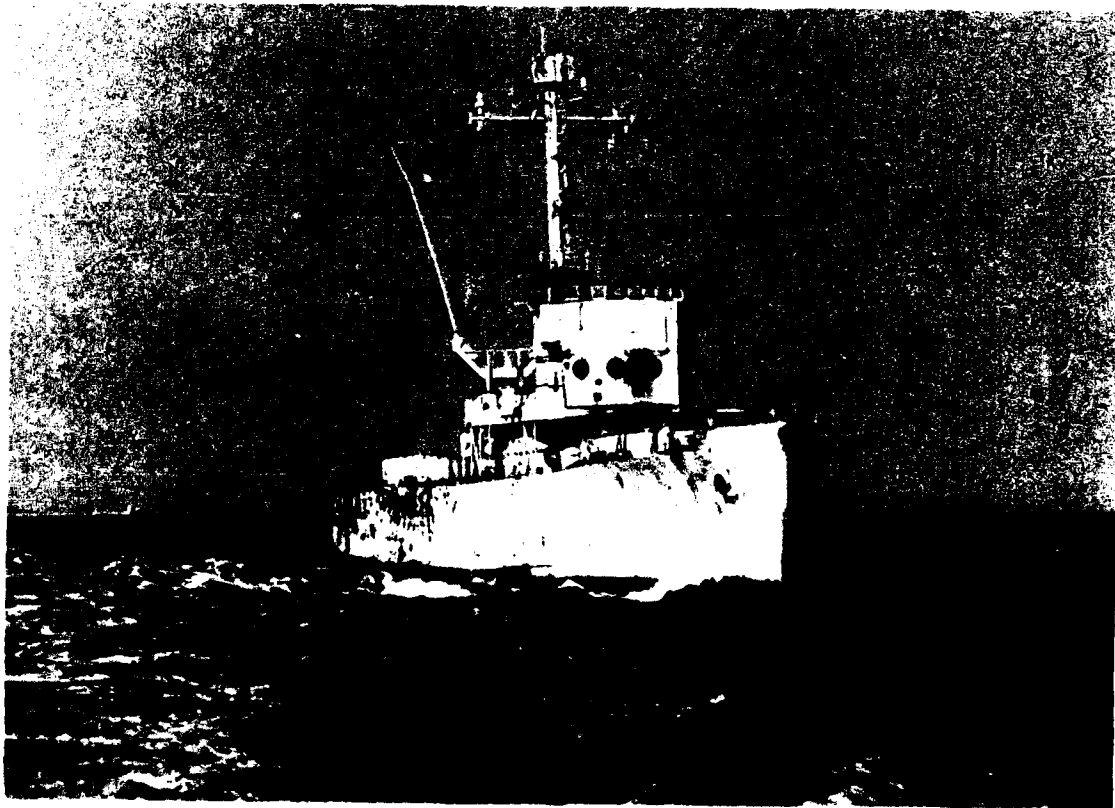

Figure 1 Wolf frigate

Pressure, strain, acceleration etc. were recorded during the Wolf Phase II bare charge experiments. These experiments were performed in the crew aft as well as the crew forward sleeping compartment. In the crew aft sleeping compartment, the 2, 5.5 and 15 kg TNT bare charge experiments were performed on one day. The volume of this compartment was  $\pm 77 \text{ m}^3$ , thus realizing a "charge density" of  $\pm 0.026$ ,  $\pm 0.072$  and  $\pm 0.20 \text{ kg/m}^3$ .

The 3 and 12 kg TNT bare charge experiments were performed in the crew forward sleeping compartment also on one day. The volume of this compartment was  $\pm 105 \text{ m}^3$ , thus resulting in a "charge density" of  $\pm 0.029$  and  $\pm 0.11 \text{ kg/m}^3$ .

During these Phase II experiments, special attention was paid to the blast resistance of the watertight doors (i.e. the 2, 3 and 5.5 kg TNT experiments), the resistance of the structure (the 12 kg TNT experiment) and the rupture of structural elements (the 15 kg TNT experiment).

The results of the instrumented Wolf Phase II experiments presented conform to the previous reports dealing with the recordings of the Fret and Wolf Phase I experiments. Each report can be regarded as an independent report. It goes without saying that it is not within the scope of these reports to discuss the recordings in detail or even to compare the recordings with theoretical predictions. That will be an integral part of the reports presented by van Erkel (1992).

Nevertheless, some additional information is given concerning the reliability of the presented recordings.

Due to the increased knowledge and experience gained from the Fret and Wolf Phase I trials, modified mounting and protection techniques were used during the Wolf Phase II trial. It is for this reason that a separate report deals with the general background information as well as the mounting and protection methods used. For the sake of completeness, a description is also given of the registration equipment and the signal analysis system used.

This report deals with the bare 12 kg TNT experiment in the crew forward sleeping compartment.

Some general remarks on the experiment are given in Chapter 2, as well as some specific information on the charge used. In the following chapters, the recordings are presented.

Offset elimination was carried out. The time axis was related to the moment of ignition of the charge ( $t=0$ ).

Because the 3 and 12 kg TNT experiments in the crew forward sleeping compartment were performed in one day, hardly any time was left between the experiments for the technicians to

modify or repair the instrumentation equipment. Damage due to the 3 kg TNT experiment earlier that day was not repaired.

Some abbreviations often used are BHD (Bulkhead), SB (Starboard), PS (Portside) and CL (Centre line frigate).

## 2 DESCRIPTION OF THE EXPERIMENT

### 2.1 Objective of the experiments

One of the objectives of the ROOFDIER trials is the validation of the computer code "DAMINEX" as developed by Weapon Effectiveness Department of the TNO - Prins Maurits Laboratory.

The DAMINEX code determines the structural damage to a frigate due to internal blast. A number of theoretical assumptions were made during the development of this code, which however may have a large influence on the final simulation results.

In general, the damage caused by the experiments is registered visually. It is for this reason that a lack of quantitative information is still apparent. The specific goal of the ROOFDIER experiments is to gain more quantitative as well as qualitative information by performing well-documented experiments. This information will be used to validate (or even modify) the DAMINEX code.

### 2.2 Experimental set-up

Two crew sleeping compartments were selected by the Weapon Effectiveness Department for the instrumented experiments: the crew forward sleeping compartment and the crew aft sleeping compartment. These two compartments correspond with the crew sleeping compartments used during the FRET experiments. As a consequence, these experiments can be compared with the FRET experiments, during which (bare) charges of 8 kg and 12 kg TNT were used.

The crew forward sleeping compartment (height: 2.25 m, length: 5.5 m, width: 8.35 m - 9.35 m) was cleared as much as possible of all obstacles. Preceding the experiments, a venting hole (diameter 20 cm) was made in the centre of the SB hull of the compartment to simulate the hull's penetration by a warhead and to enable quicker venting after the experiment.

The experiment compartment was used earlier that day for the bare 3 kg TNT experiment. As a consequence, some transducers were damaged and could not be repaired/replaced in time (mainly strain gauges).



During the 3 kg TNT experiment, slight pressure fluctuations were measured in the adjacent compartments. From this it was concluded that the damage to the structure was minimal and therefore was not repaired.

The charge used during this particular experiment was a cast cylindrical charge with  $L/D=2$ ,  $D=168$  mm, resulting in a bare charge of 12 kg TNT. The charge was placed in the centre of the compartment at midheight. This location corresponds with the 3 kg TNT experiment, however the charges' geometries differ considerably. The charge was ignited at its centre with one electrical detonator (No. 8) and a booster of three RDX cartridges ( $L/D=1$ ,  $D=50$  mm). The geometry and orientation as well as an impression of the charge are shown in Figures 2 and 3. Figure 4 shows the compartment after the experiment was performed.

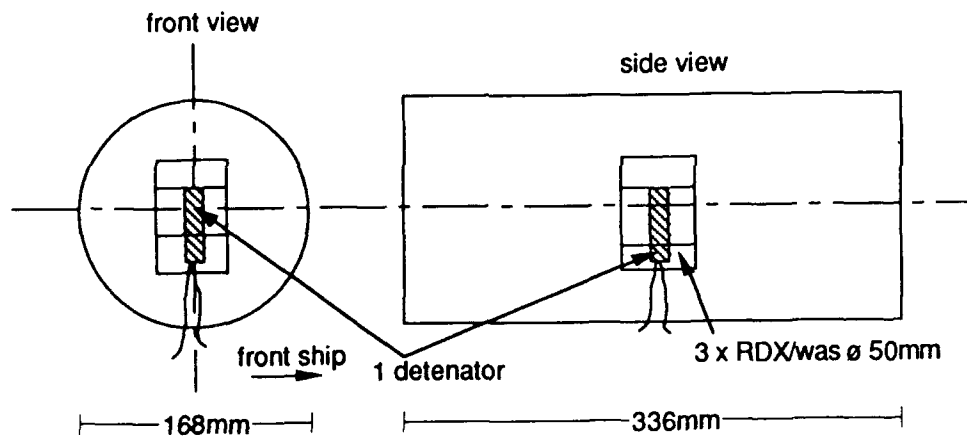

Figure 2 Geometry of the charge

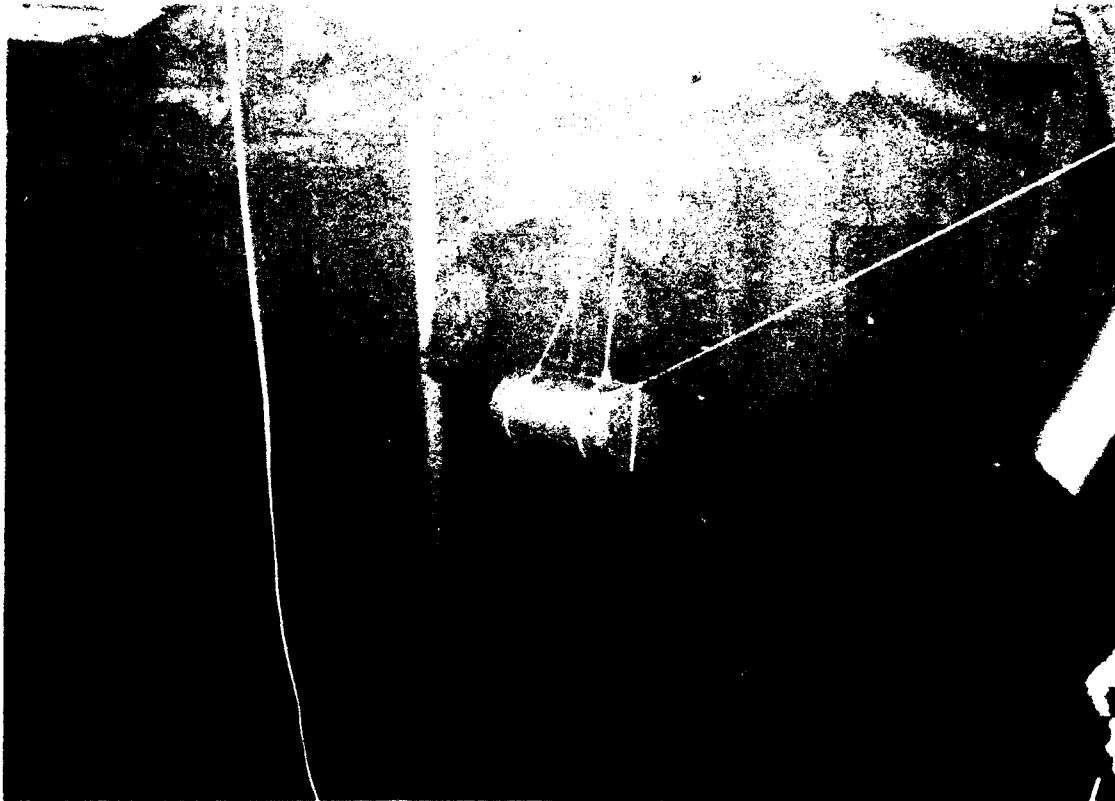

Figure 3 Impression of the experimental set-up and charge



Figure 4 The compartment after the experiment was performed

### 3 PRESSURE MEASUREMENT

#### 3.1 Position of the pressure transducers

To measure the overpressure, six piezo-electric pressure transducers B1-B6 were used, all mounted in the experiment compartment. B1 and B2 were mounted on the hull of the frigate whereas B3-B5 were mounted on bulkhead 32. B6 was mounted on the ceiling of the compartment. The transducers were mounted at about midheight in the compartment. The positions are summarized in Table 2 and shown schematically in Figures 5 and 6.

Table 2 Position of pressure transducers

Device	Height	Mounting position
B1 (*)	112 cm	on hull SB, 179 cm from BHD 23 on stiffener
B2	114 cm	on hull PS, 184 cm from BHD 23 on stiffener
B3	112 cm	on BHD 32, 63 cm from CL
B4	112 cm	on BHD 32, 174 cm from CL
B5	112 cm	on BHD 32, 286 cm from CL
B6	ceiling	40 cm from SB, 42 cm from BHD 32

(\*) in vicinity of the venting hole

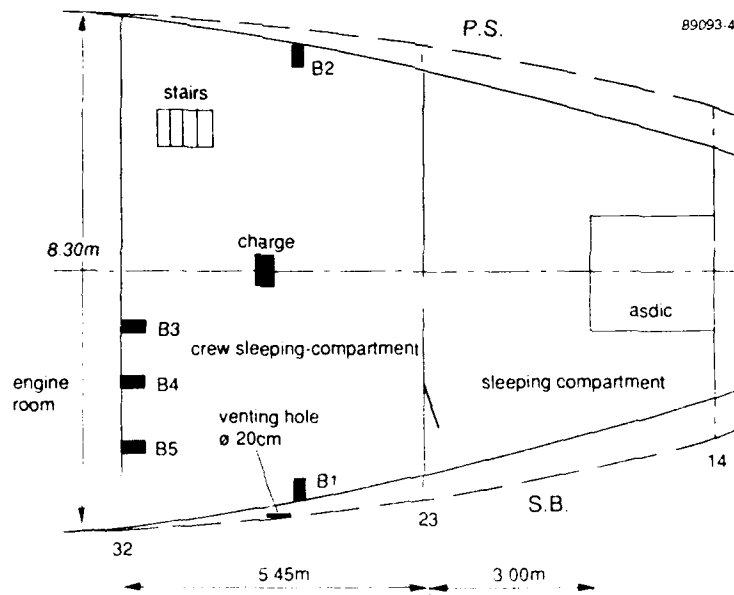

Figure 5 Schematic illustration of the position of the pressure transducers

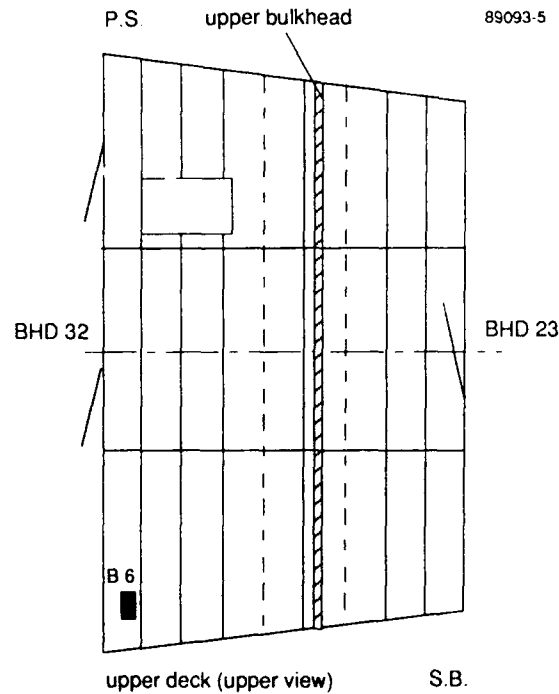

Figure 6 Schematic illustration of the position of the pressure transducers

### 3.2 Discussion of the pressure measurements

The recorded pressure signals are presented in Figures 7, 8 and 9. At first glance, these recordings show reliable signals. Transducer B4 seems to drift, probably due to temperature influences. This drift also became apparent from the 3 kg TNT recording. The strong negative pressure registered by transducer B6 after 8 ms could not be explained. This may be due to reflections. The transducer was mounted on the ceiling at the edge of the experiment compartment.

To get a more objective impression of the reliability of these recordings, the registered first peak pressure and the arrival time of the shock front were compared with theoretical predictions. To this end, the geometry of the charge was simplified to a spherical charge. It was assumed that this 'theoretical charge' was centrally ignited. The theoretical predictions according to Baker (1983,

Figures 2.45 and 2.46) are collected in Table 3. The experimental values are also given in this table.

Table 3 Comparison of recorded and predicted (first) peak pressure and arrival time

Device	d(D,C) [m]	Z [m/kg <sup>1/3</sup> ]	Peak pressure		Arrival time	
			Exp. [kPa]	Theor. [kPa]	Exp. [ms]	Theor. [ms]
B1 <sup>(1)</sup>	3.90	1.70	611	1144	2.2	3.1
B2	3.90	1.70	1666	1144 (1627) <sup>(3)</sup>	2.3	3.1
B3	2.80	1.22	5594	2185 (5440) <sup>(3)</sup>	1.4	1.6
B4	3.35	1.46	965	1500	2.6	2.3
B5	4.00	1.75	713	1100	4.3	3.2
B6	4.80	2.10	2626	630	5.6	4.7

d(D,C) : distance between Device and Charge

Z : scaled distance [m/kg<sup>1/3</sup>]

(1) : in vicinity of venting hole

(2) : Theoretical values for a centrally ignited, spherical charge (Baker 1983, Figure 2.45 and 2.46)

(3) : Theoretical peak pressures for a cylindrical charge (L/D=2), (Baker, 1980, Form. 4.34)

Comparing the arrival times of the shock front shows that in some situations the predicted shock front arrival overrates the recordings (B1, B2, B3), whereas for the remaining transducers, the theoretical values underrate them.

The theoretical and recorded peak pressures do not fit very well. In some situations, the theoretical predictions overestimate the recordings (B2) by up to a factor 2, others underrate the recordings by up to a factor 4 (B6). Transducers B1 and B2, located symmetrically with respect to the centre of the charge, show a considerable discrepancy in peak pressures although the arrival times of the shock front correspond well. The theoretical predicted peak pressure appeared to be the averaged value of B1 and B2.

From this it must be concluded that the simplification of the charge geometry used for the theoretical predictions does not hold. The geometry of the charge greatly influences the recorded pressures and should therefore be taken into account for the theoretical predictions.

With Baker (1980, Formula 4.34), it is possible to give theoretical predictions of peak pressures from cylindrical charges ignited at one end plane of the cylinder. Using  $L/D=2$  in this expression resulted in predictions for transducers B2 and B3 which correspond remarkably well with the experimental values (see Table 3). The predictions for the remaining transducers were omitted, as these should be corrected to deal with non-perpendicular reflections.

From these considerations concerning the pressure recordings, it can be concluded that the use of a simplified (theoretical) spherical charge does not result in correct predictions for peak pressures and shock front arrival times. Using predictions based on a cylindrical charge improved the predictions considerably. The charge geometry and the way and place where the charge is ignited appeared to have a great influence on the pressure predictions (on the used scaled distances).

The pressure recordings in the experiment compartment resulted in reliable pressure signals, notwithstanding discrepancies with theoretical predictions based on simplified charge geometries.

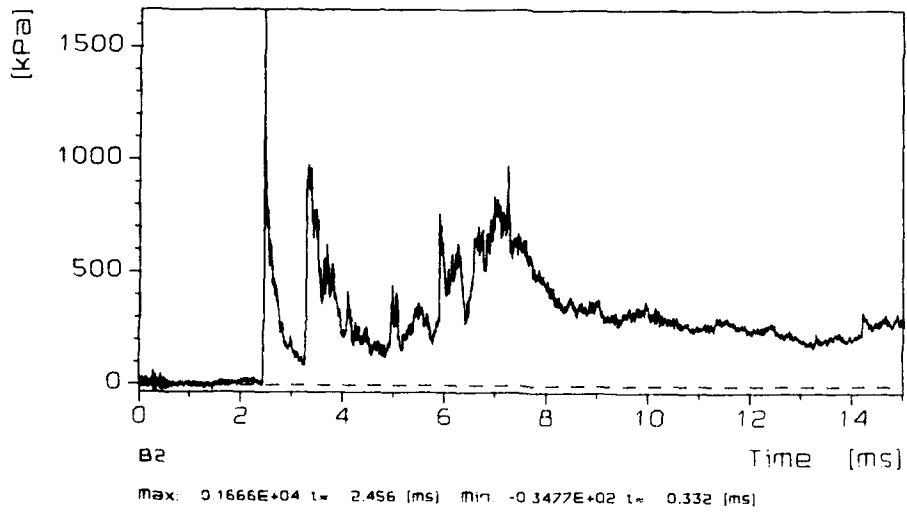
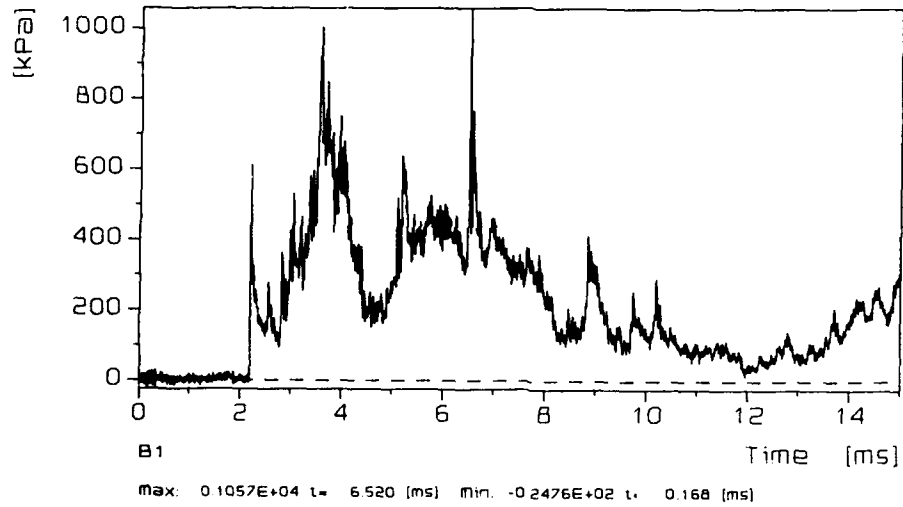

Figure 7 Pressure signals B1 (SB hull) and B2 (PS hull)



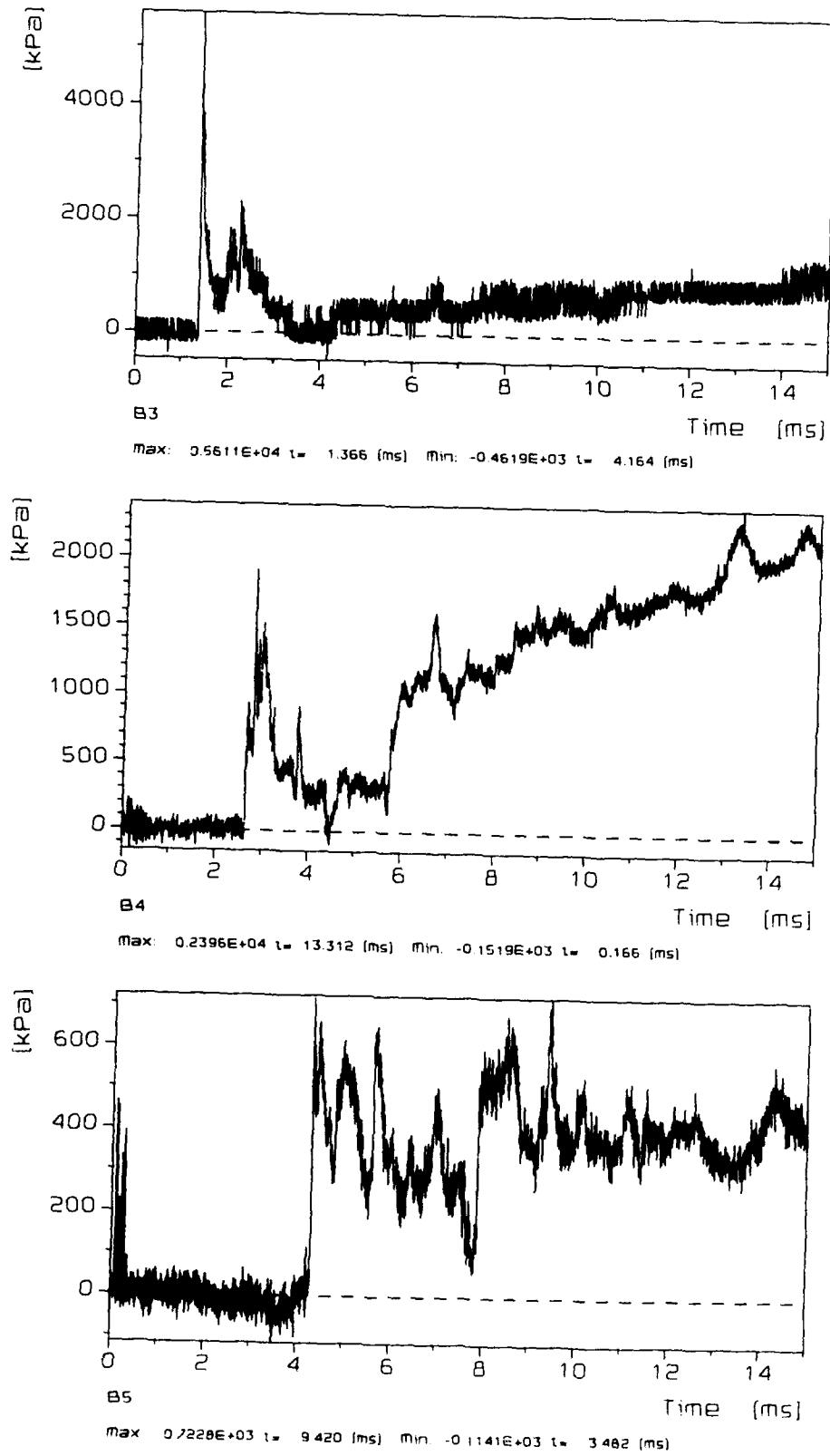

Figure 8 Pressure signals B3, B4 and B5 (BHD 32)

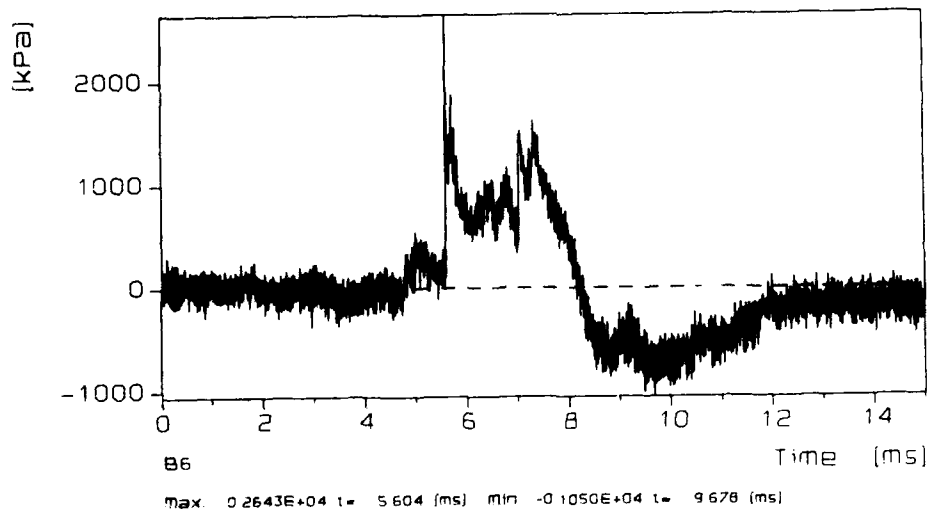

Figure 9 Pressure signal B6 (on ceiling corner)

## 4 QUASI-STATIC PRESSURE MEASUREMENT

### 4.1 Position of the quasi-static pressure transducers

The quasi-static pressure was registered with piezo resistive transducers at six different locations (Q1-Q6). Two transducers (Q1, Q2) were placed in the crew sleeping compartment. The other transducers were placed in the neighbouring compartments, i.e. three transducers (Q3, Q4, Q5) in the corporals' sleeping quarters/mess, one (Q6) in the officers' room which is located above the experiment compartment. The positions of the transducers are summarized in Table 4 and shown schematically in Figures 10 and 11.

Table 4 Position of the quasi-static pressure transducers

Device	Height	Position
Q1 <sup>(1)</sup>	128 cm	14 cm in front of the hull, SB
Q2	127 cm	14 cm in front of the hull, PS
Q3	107 cm	320 cm behind door on frame 18, SB
Q4	100 cm	52 cm from CL, on wall ASDIC room
Q5	113 cm	150 cm from BHD 14, on wall ASDIC room
Q6	114 cm	44 cm from door in BHD 32, in officers' room

(1) in vicinity of venting hole

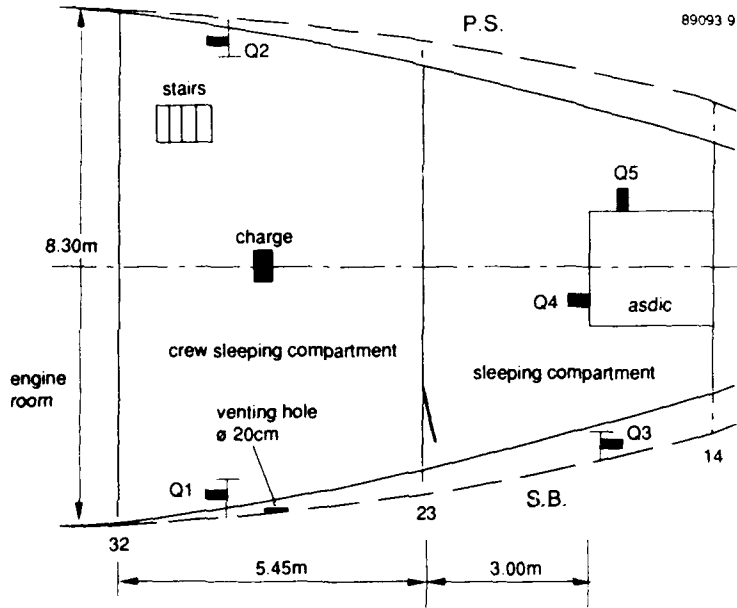

Figure 10 Schematic illustration of the quasi-static pressure transducers positions

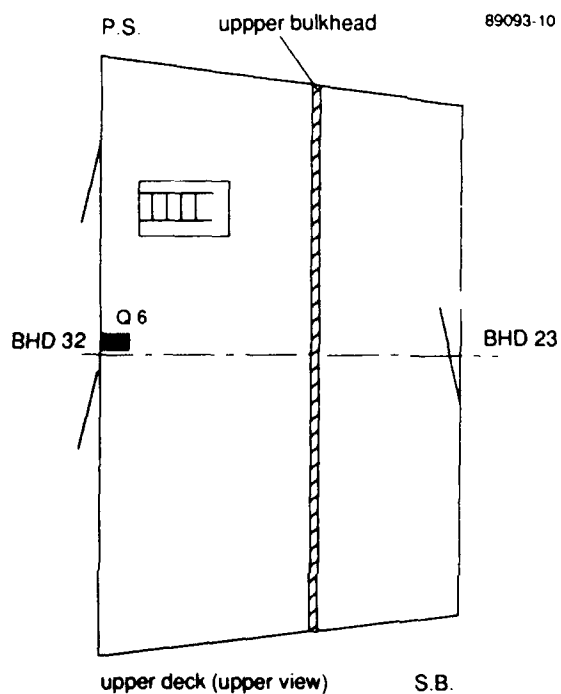

Figure 11 Schematic illustration of the quasi-static pressure transducers positions

#### 4.2 Discussion of the quasi-static pressure measurement

The registered quasi-static pressures are presented in Figures 12-15. Unfortunately, transducer Q6 malfunctioned after 100 ms. Transducers Q3, Q4, Q5 and Q6 were placed in the adjacent compartments. From their figures it appears that these transducers start reacting after 10-15 ms and the quasi-static pressure increases up to  $\pm 200$  kPa ( $t=50$  ms). During this time period, the quasi-static pressure in the experiment compartment drops to  $\pm 200$  kPa, i.e. at  $t=50$  ms the quasi-static pressure in the experiment compartment as well as in the adjacent compartments was  $\pm 200$  kPa. Later on, the quasi-static pressure had comparatively decayed.

From this it may be deduced that the damage to the bulkhead was realized in the first 15 ms, thus effecting a drastic enlargement of the experiment compartment.

According to Baker (1983, Figure 3.15), a theoretical quasi-static pressure of  $\pm 400$  kPa is found based on a 12 kg TNT charge and a compartment volume of  $105 \text{ m}^3$ . The Weibull relation leads to

460 kPa. These theoretical values overestimate the quasi-static pressures of Q1 and Q2 (in the experiment compartment) (300 kPa), although one should realize that the 'leakage' to the adjacent compartments already started after 15 ms.

In Table 5, the arrival time  $T_a$ , the maximum pressure  $P_{max}$  and time  $T_{max}$  are summarized.

Table 5 Quasi-static pressure measurement

Device	$T_a$ [ms]	$P_{max}$ [kPa]	$T_{max}$ [s]
Q1	2.0	300 <sup>(1)</sup>	30
Q2	2.3	300 <sup>(1)</sup>	30
Q3	11.4	250	50
Q4	10.6	230	50
Q5	14.3	260	50
Q6	5.8	160	50

<sup>(1)</sup> based on the first 50 ms

Theoretical predictions based on an enlarged compartment volume of  $\pm 300 \text{ m}^3$  (due to the destruction of the bulkheads) lead to quasi-static pressures of  $\pm 220 \text{ kPa}$  (Weibull) which compare well with the recordings from 50 ms onwards.

From these observations it may be concluded that the quasi-static pressure recordings are reliable. An indication of the destructive processes could also be deduced.

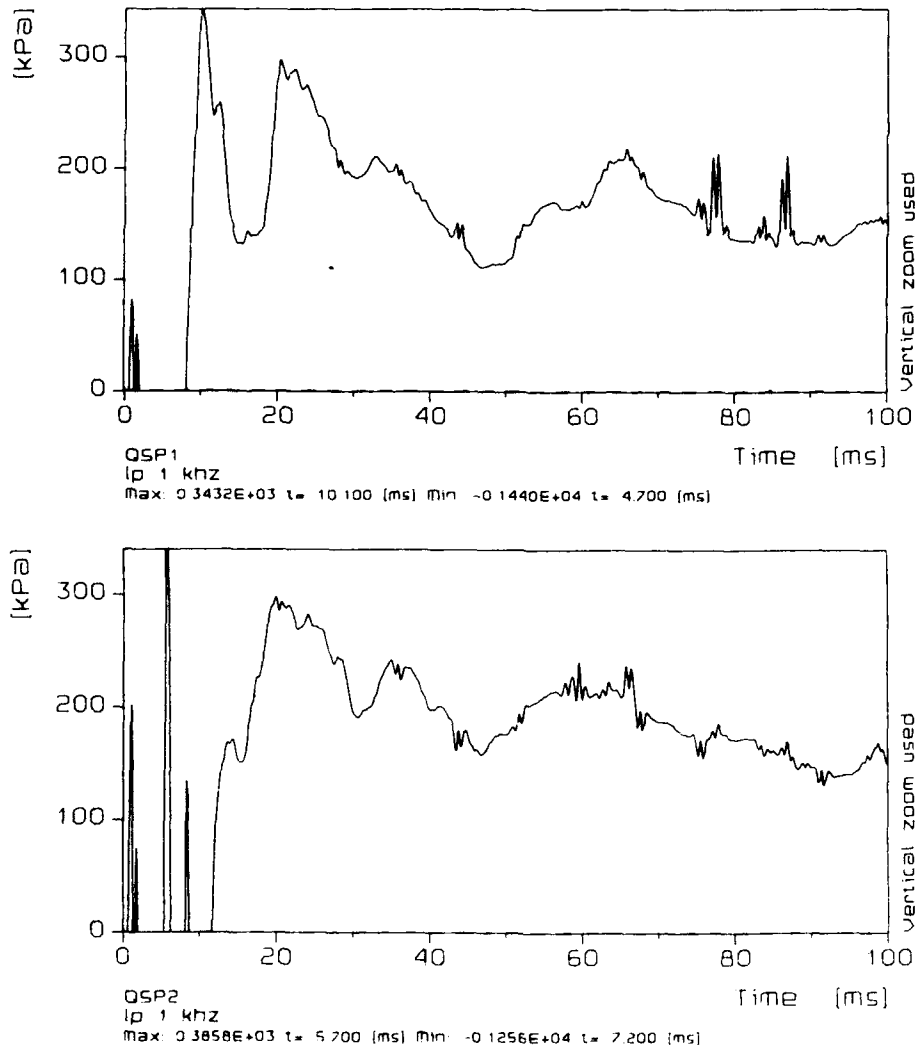

Figure 12 Quasi-static pressure signals Q1, Q2 (in the experiment compartment) (short time base)

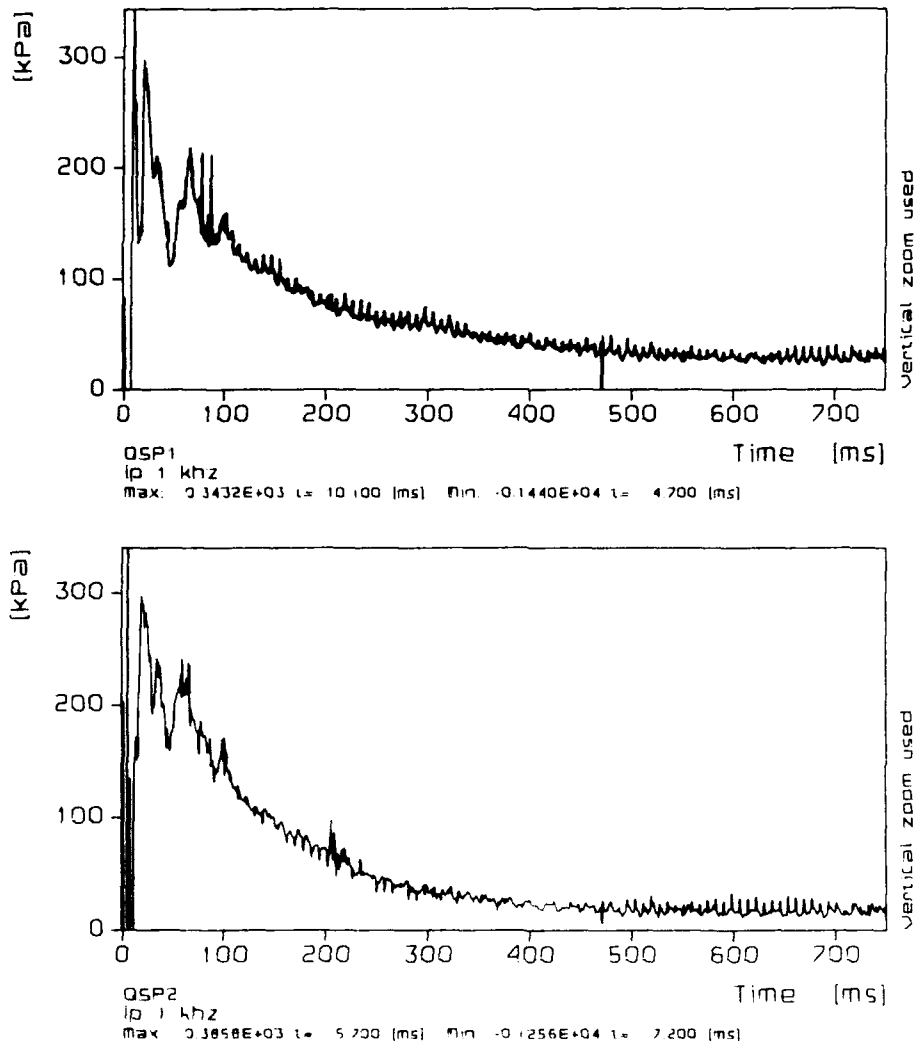

Figure 13 Quasi-static pressure signals Q1, Q2 (in the experiment compartment)



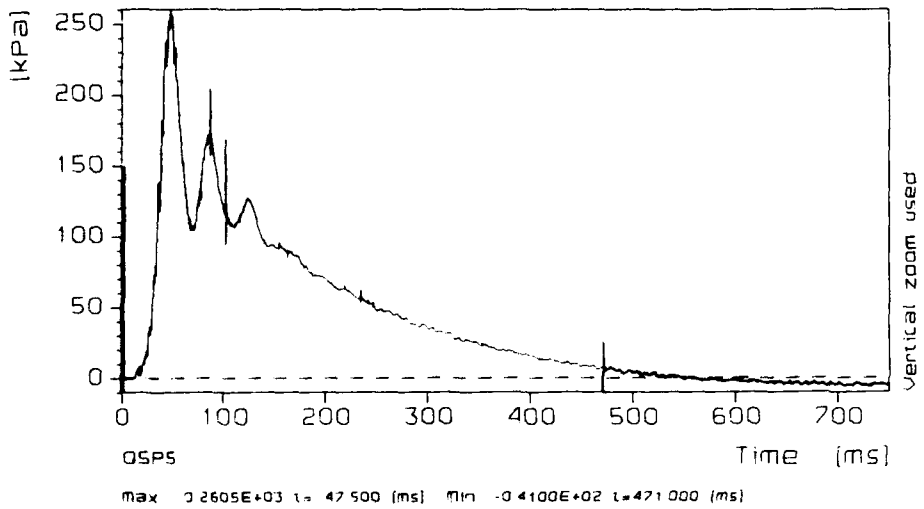
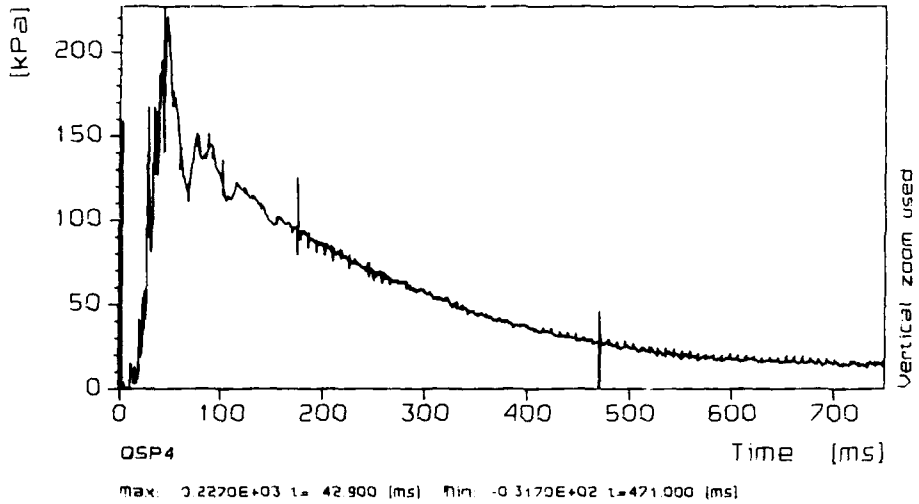
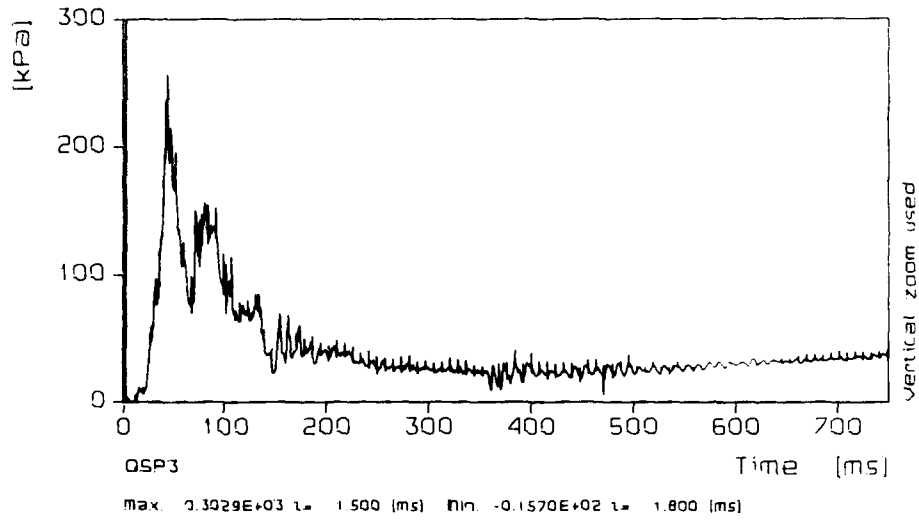

Figure 14 Quasi-static pressure signals Q3, Q4 and Q5

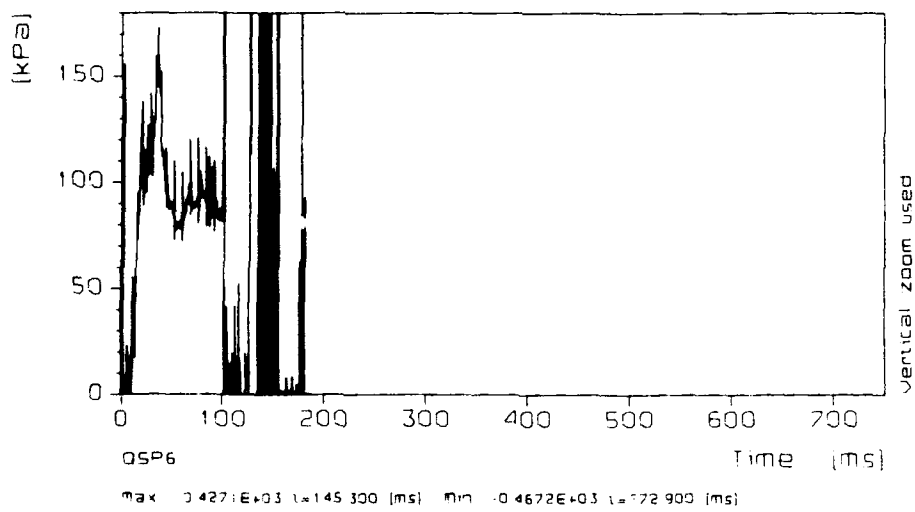

Figure 15 Quasi-static pressure signal Q6







## 5 STRAIN MEASUREMENT

### 5.1 Position of the strain gauges

The strain was measured using eight 2% and nineteen 10% strain gauges in twenty-seven positions (S1-S27) during the experiment. Some of the strain gauges were placed singly, while others were placed in pairs, opposite each other.

The positions of the strain gauges are summarized in Tables 6-9 and shown schematically in Figures 16-20; a subdivision was used.

To visualize the location of the strain gauges, the following notation was used:

-  : 2% strain gauge, single, front side
-  : 2% strain gauge, single, back side
- d  : 2% strain gauge, double, both sides
  
-  : 10% strain gauge, single, front side
-  : 10% strain gauge, single, back side
- d  : 10% strain gauge, double, both sides

The "front side" or "back side" description is related to the plane of view as shown in the figures.

Table 6 Strain gauge positions on the hull (all in experiment compartment)

Device	Range	Height	Mounted on:
S1	2%	96 cm	Frame 29, midheight, SB
S2	2%	97 cm	Frame 29, midheight, PS

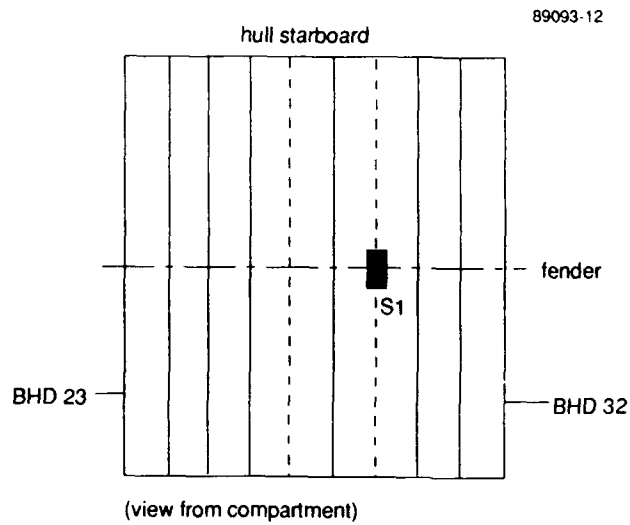

Figure 16 Schematic illustration of strain gauge position S1 (SB)

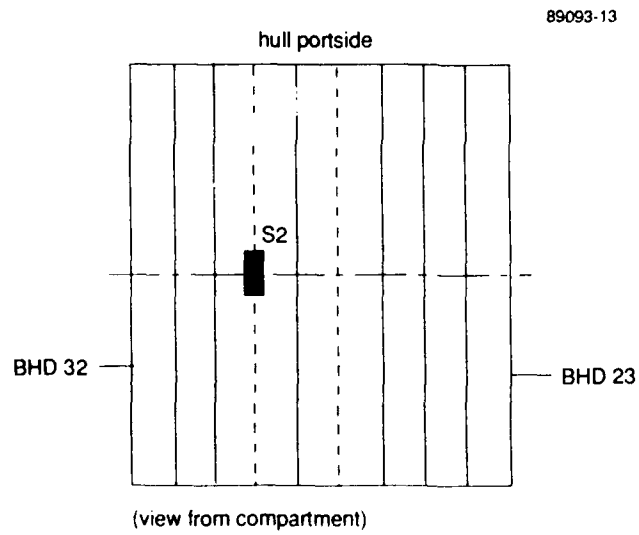

Figure 17 Schematic illustration of strain gauge position S2 (PS)

Table 7 Strain gauge positions on BHD 23

Device	Range	Opposite	Height	Mounted on:
S3	10%	---	82 cm <sup>(2)</sup>	31 cm from door case
S4 <sup>(1)</sup>	10%	S5	7 cm <sup>(3)</sup>	8 cm from stiffener
S5	10%	S4	6 cm <sup>(3)</sup>	
S6 <sup>(1)</sup>	10%	S7	112 cm	26 cm from stiffener
S7	10%	S6	112 cm	
S8 <sup>(1)</sup>	10%	S9	112 cm	8 cm from stiffener
S9 <sup>(*)</sup>	10%	S8	112 cm	
S10 <sup>(1,*)</sup>	10%	S11	113 cm	centre stiffener
S11	10%	S10	112 cm	
S12 <sup>(1)</sup>	10%	S13	7 cm	26 cm from stiffener
S13 <sup>(*)</sup>	10%	S12	7 cm	
S14 <sup>(1)</sup>	10%	S15	7 cm	8 cm from stiffener
S15	10%	S14	7 cm	
S16	10%	---	7 cm	back of stiffener
S17 <sup>(4)</sup>	2%	S18	15 cm	back of stiffener
S18 <sup>(4)</sup>	2%	S17	15 cm	on stiffener
S19 <sup>(4)</sup>	2%	S20	40 cm <sup>(3)</sup>	back of stiffener
S20 <sup>(4)</sup>	2%	S19	40 cm <sup>(3)</sup>	on stiffener

(1) in experiment compartment

(2) from bottom side door

(3) beneath ceiling

(4) in officers room above experiment compartment

(\*) malfunctioned during the 3 kg TNT experiment

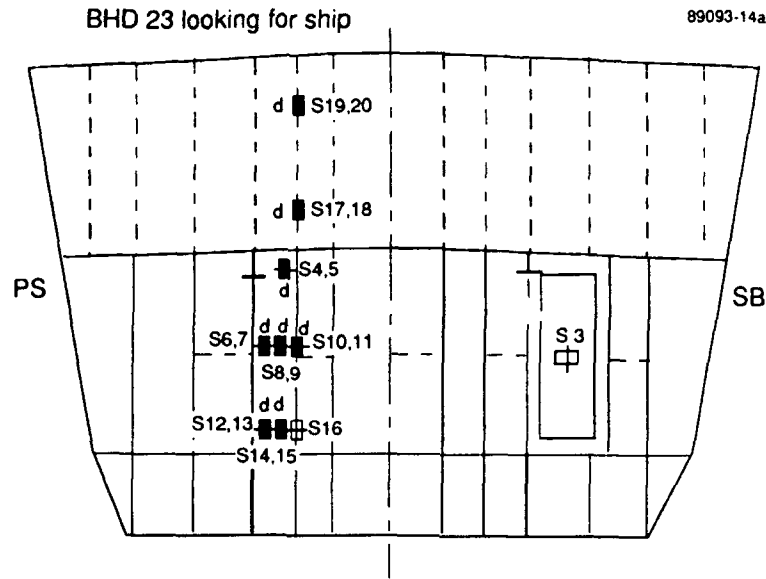

Figure 18 Schematic illustration of strain gauges position on BHD 23

Table 8 Strain gauges positions on BHD 32

Device	Range	Opposite	Height	Mounted on:
S21	10%	---	217 cm <sup>(1)</sup>	in machine room
S22	2%	S23	120 cm	back stiffener officers' galley
S23	2%	S22	120 cm	stiffener officers' mess

(1) from ceiling

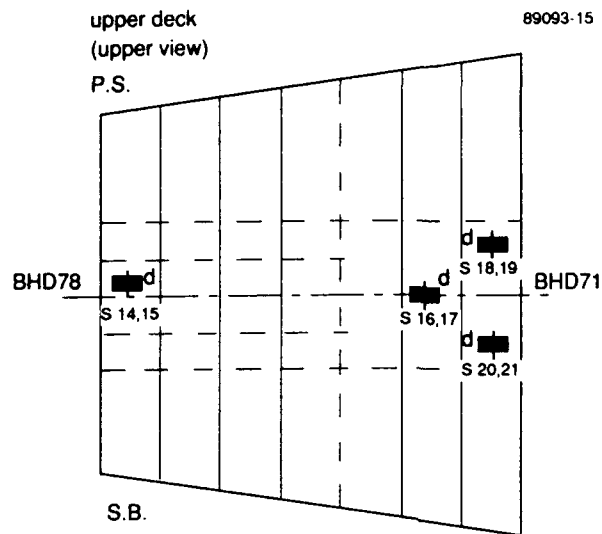

Figure 19 Schematic illustration of strain gauges positions on BHD 32

Table 9 Position of strain gauges on floor of officers' compartment above experiment compartment

Device	Range	Mounted on:
S24	10%	5 cm from SB, 181 cm from BHD 32
S25	10%	3 cm from SB girder, 308 cm from BHD 32
S26	10%	4 cm from SB girder, 181 cm from BHD 32
S27(*)	10%	back of SB girder, 177 cm from BHD 32

(\*) malfunctioned during the 3 kg TNT experiment

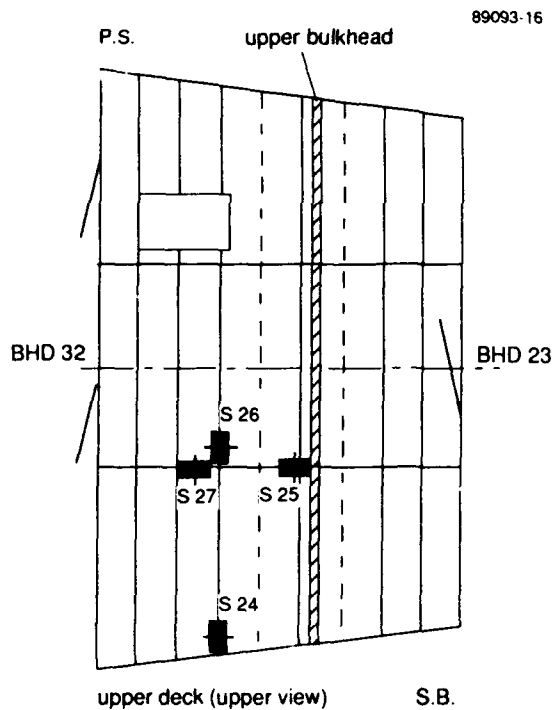

Figure 20 Schematic illustration of strain gauges positions on floor of officers' compartment which is located above the experiment compartment

## 5.2 Discussion of the strain measurements

Opposite-mounted strain gauges are shown in one figure, enabling a better understanding of the behaviour. S9, S13 and S27 are omitted due to the damage caused during the 3 kg TNT experiment earlier that day. The initial response of the S10 strain gauge seems to be reliable, although it malfunctioned during the 3 kg TNT experiment. Low pass filtering (1 kHz) was applied to some of the responses to remove noise (S1, S2, S6 and S7). Most signals are presented with respect to one time-scale. The length of the time-scale used is, in some cases, related to the moment that the transducer malfunctioned. Some signals however can be shown on an even longer time-scale.



From the quasi-static pressure measurements it was concluded that the bulkheads were destroyed during the first 15 ms after the charge ignited. During the period up to 50 ms, the pressure in the experiment compartment and adjacent compartments was equalized.

The strain gauges glued on the hull of the frigate (S1, S2) in the experiment compartment show some permanent deformation. They functioned well for a long period.

Compare the moment of malfunction of the strain gauges which were glued close together; couples S6 and S7, S8 and S9, 10 and S11. It appears that first S10 and S11, glued onto a stiffener, malfunctioned, followed by couple S8 and S9 and, finally, by couple S6 and S7. Note that the latter couples malfunctioned after  $\pm 50$  ms, i.e. after the violent pressure equalizing process took place.

*The response behaviour of couple S6 and S7 is remarkable: the first part of the recordings is 'in-phase' (longitudinal waves) which changes into 'anti-phase' (transversal waves) during the pressure equalizing process.*

The character of the strain gauge recording S3 on the watertight door in BHD 23 seems also to change nature at  $\pm 15$  ms. A malfunction occurred after  $\pm 60$  ms. From this it appears that during the first 15 ms, the door/bulkhead combination could no longer resist the strong pressure, resulting in its collapse. The door and bulkhead start to react independently.

The strain gauges glued on BHD 23 near the floor (S12, S14 and S15, S16) also show a response up to  $\pm 15$  ms.

The remaining strain measurements (outside the experiment compartment) also seem to result in reliable recordings, even during a considerably longer time period. The strain gauges glued on BHD 32 appeared to function well for a long period. Strain gauges glued on the ceiling indicate a permanent deformation, which was also visible afterwards.

The strain gauge recordings as presented in this chapter seem to be reliable up to the moment of malfunction. Malfunction can be due to the extreme conditions in the experiment compartment and demolition of the bulkheads. The overall impression (and times) of the destructive process, as concluded from the quasi-static pressure recordings, compare well with the strain gauge recordings.

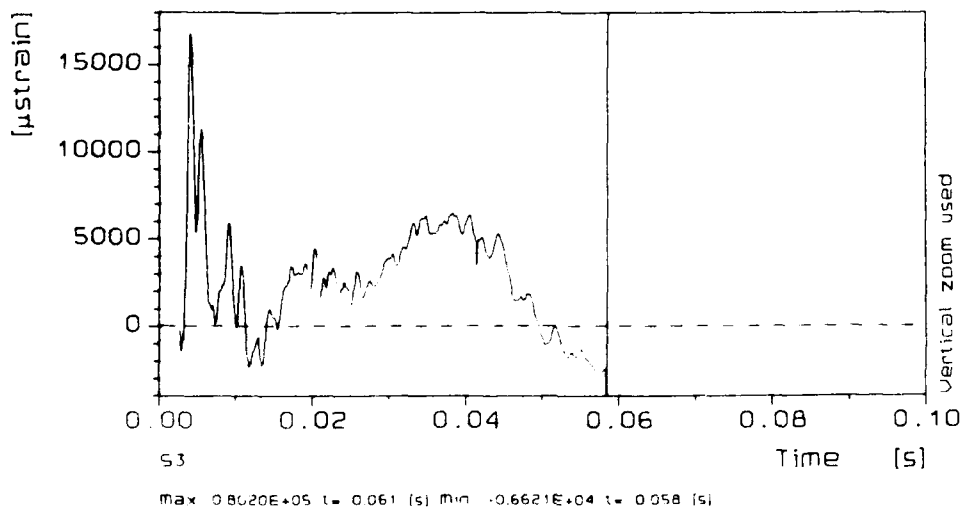
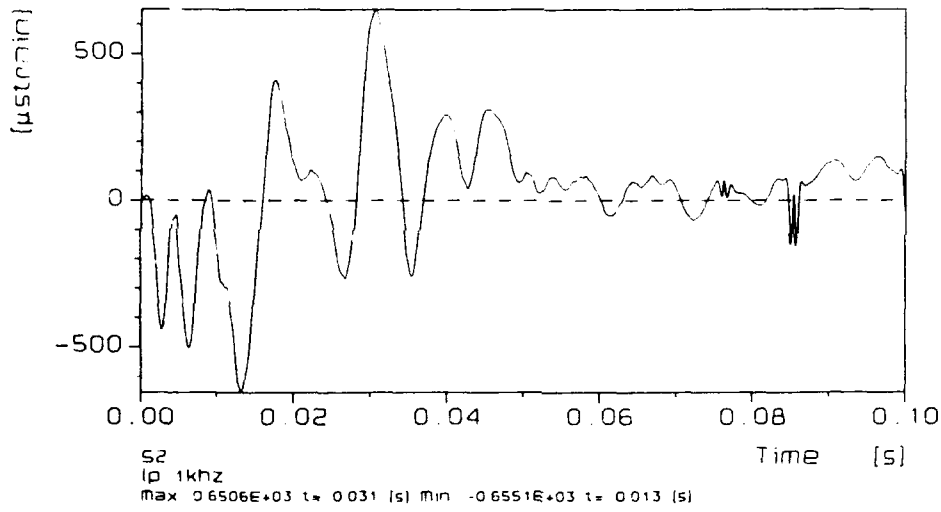
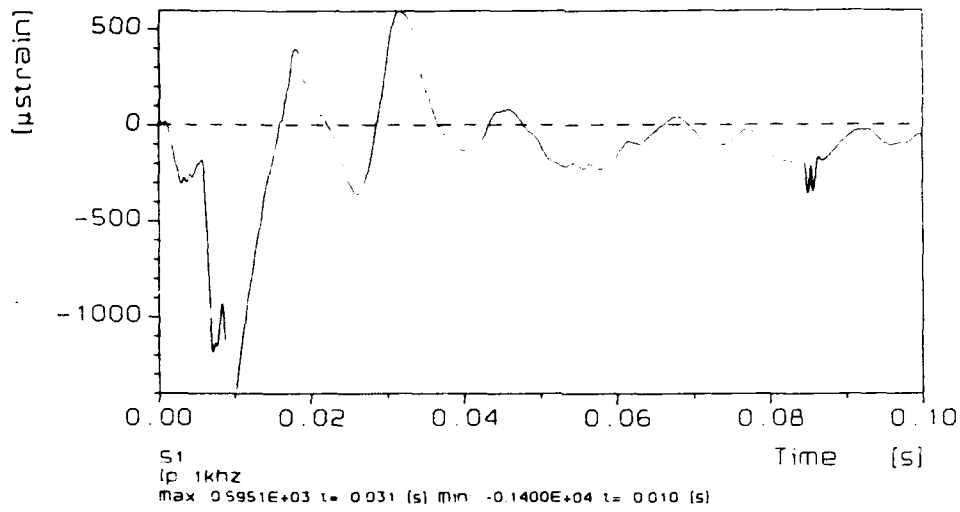

Figure 21 Strain gauge response S1, S2 (hull experiment compartment), S3 (BHD 23)

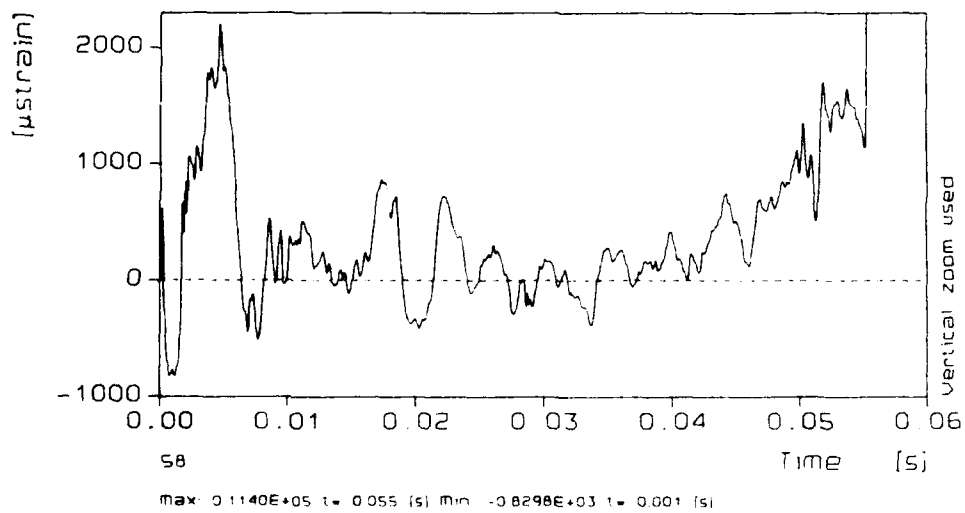
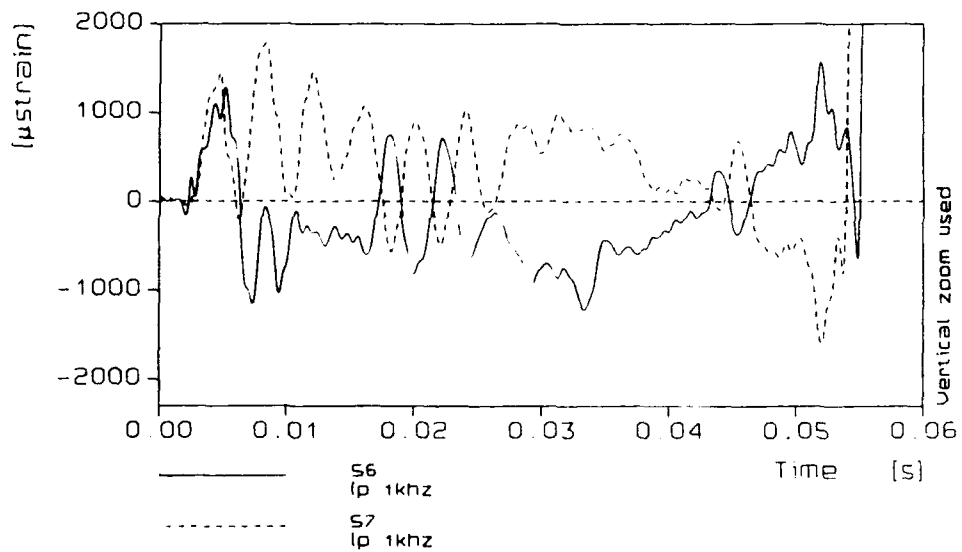
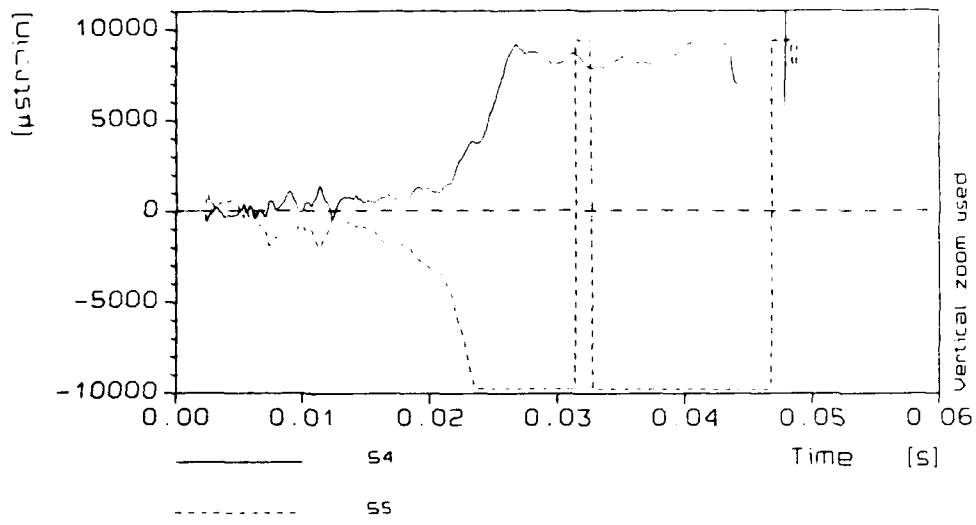

Figure 22 Strain gauge response S4 and S5, S6 and S7, S8 (BHD 23)

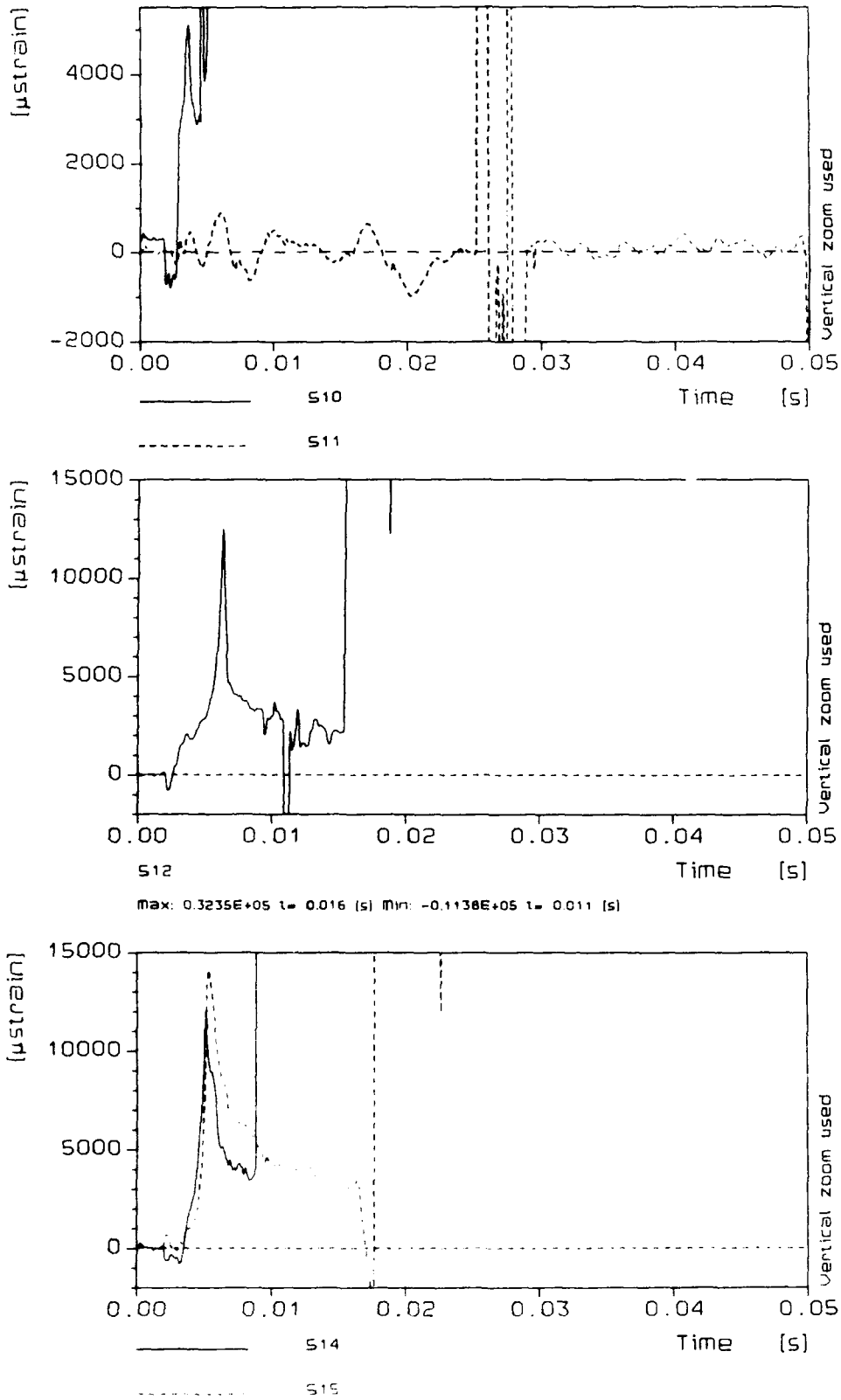

Figure 23 Strain gauge response S10 and S11, S12, S14 and S15 (BHD 23)

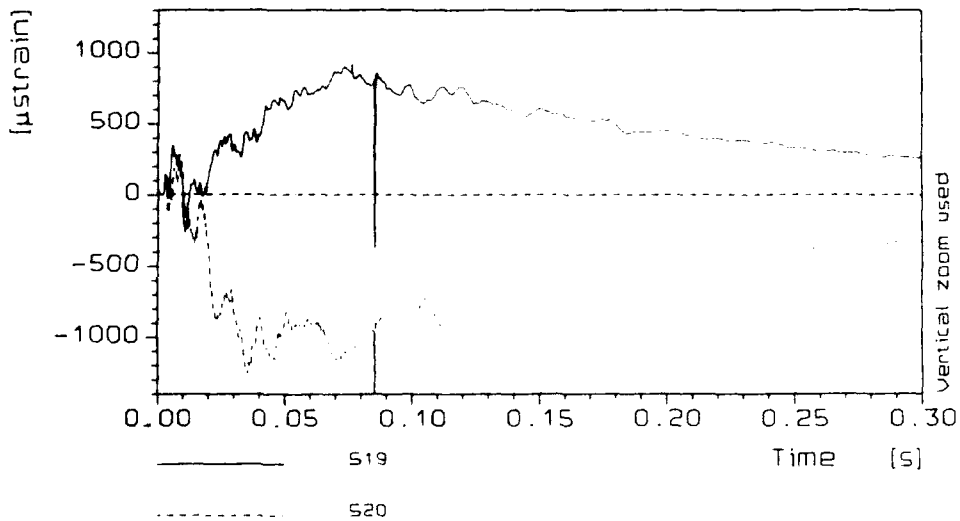
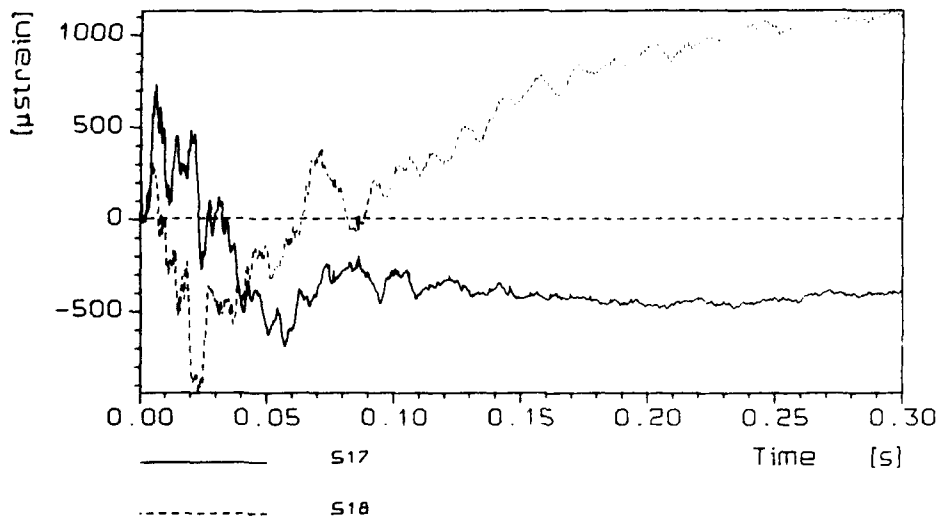
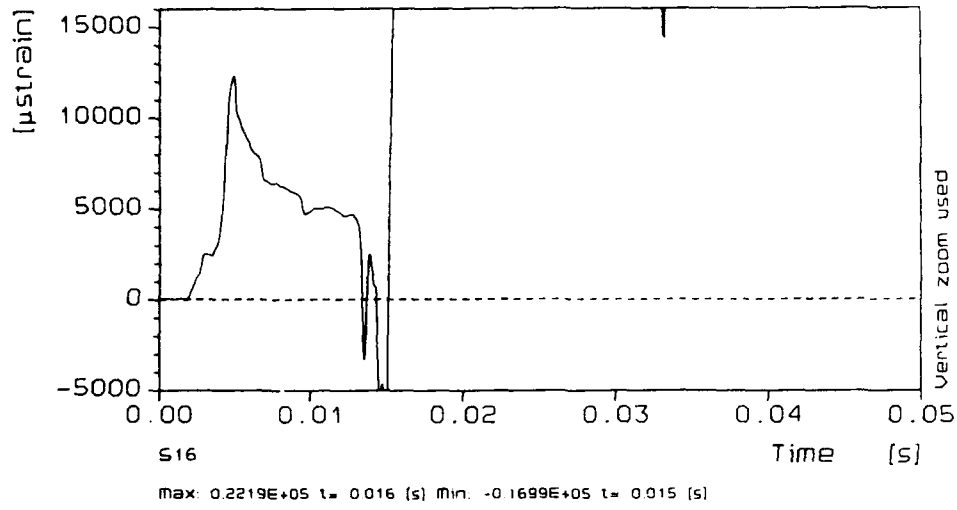

Figure 24 Strain gauge response S16, S17 and S18, S19 and S20 (BHD 23)

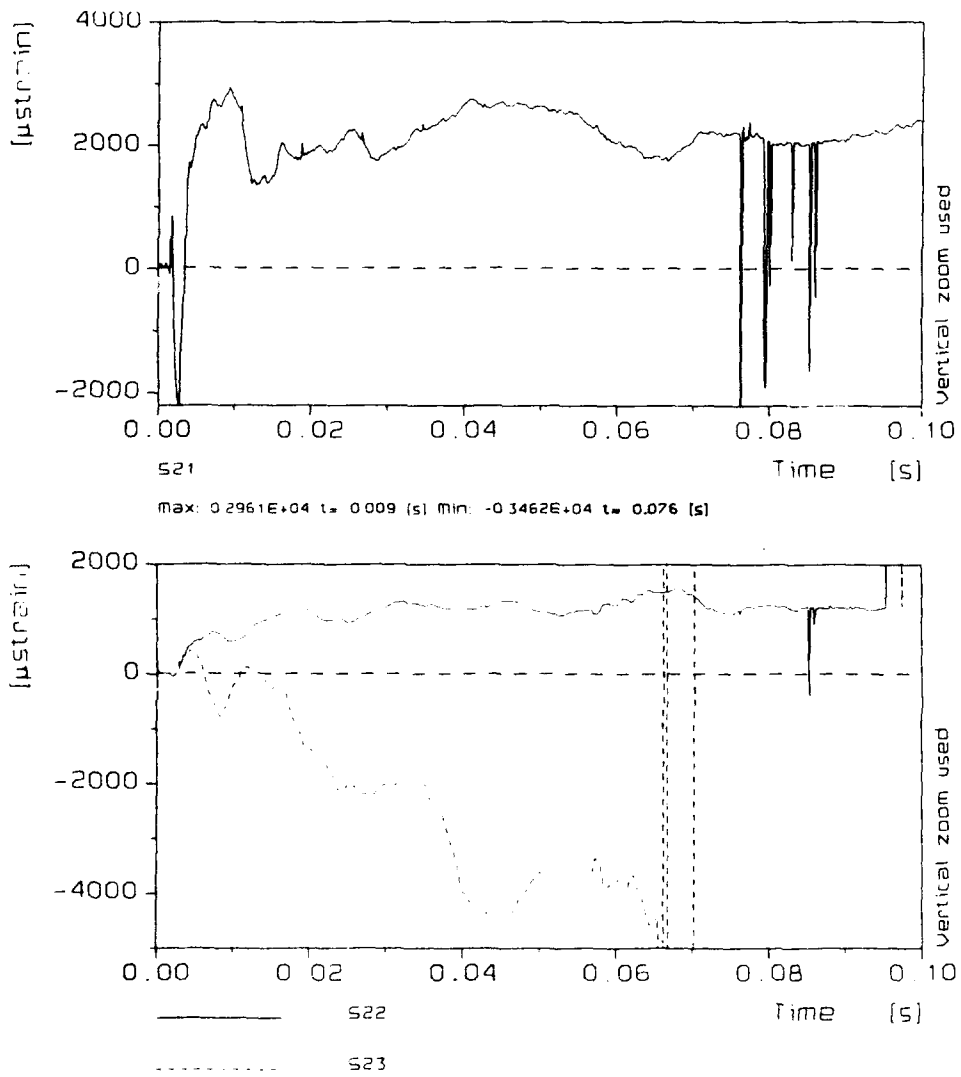

Figure 25 Strain gauge response S21, S22 and S23 (BHD 32)

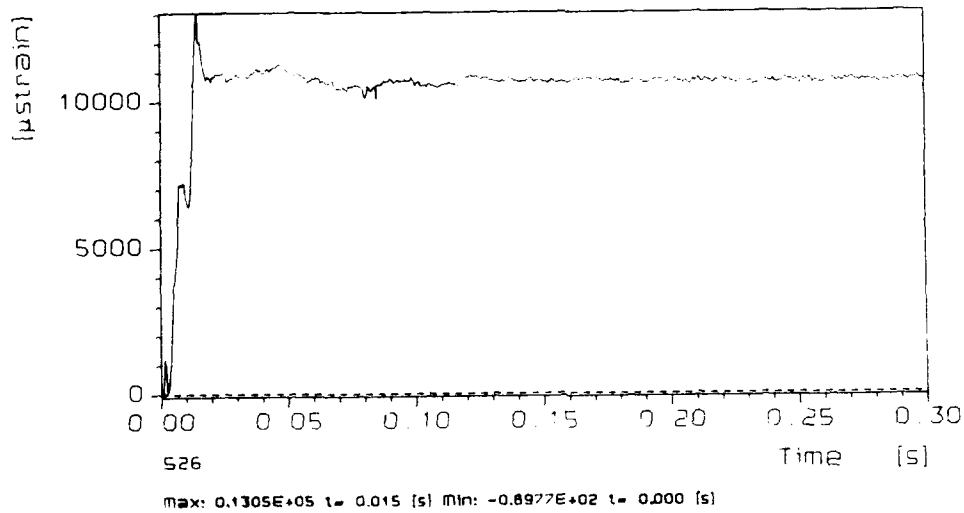
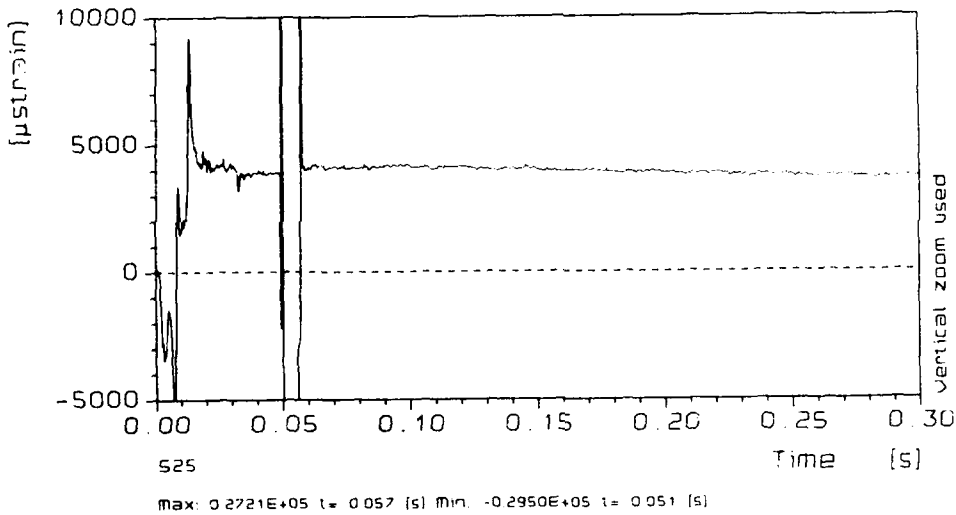
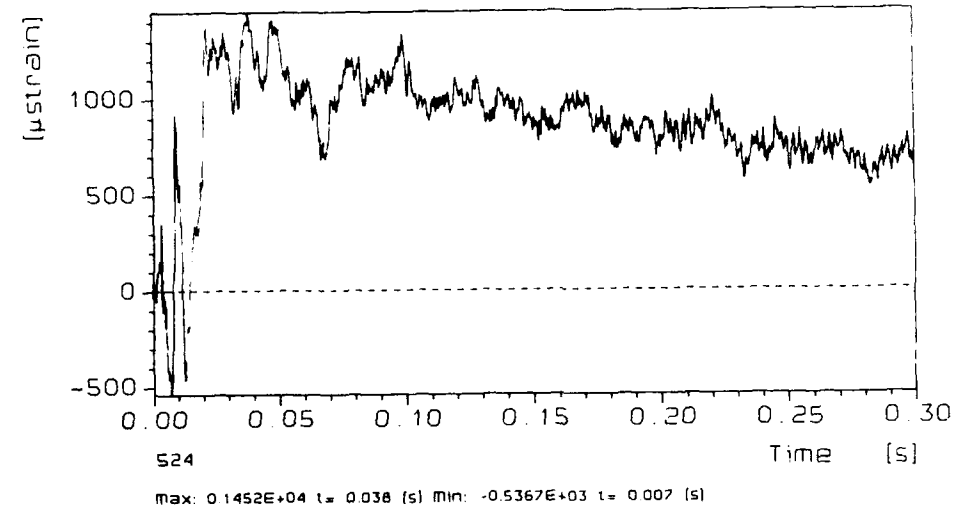

Figure 26 Strain gauge response S24, S25, S26 (floor officers' compartment)

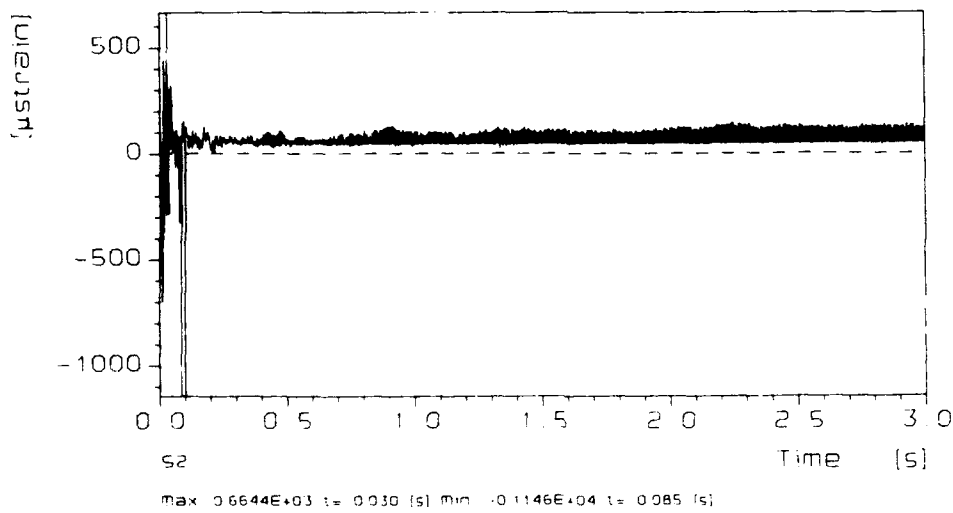
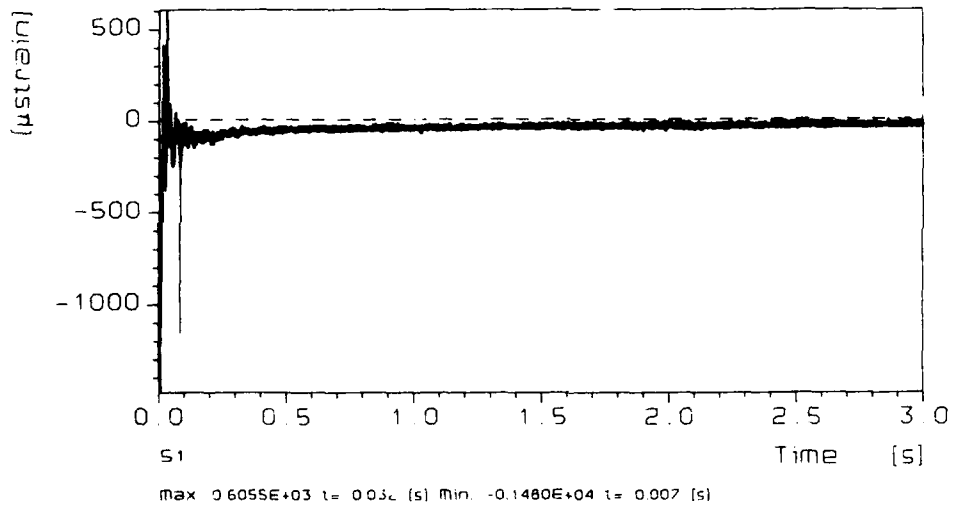

Figure 27 Strain gauge response S1, S2 (hull experiment compartment)



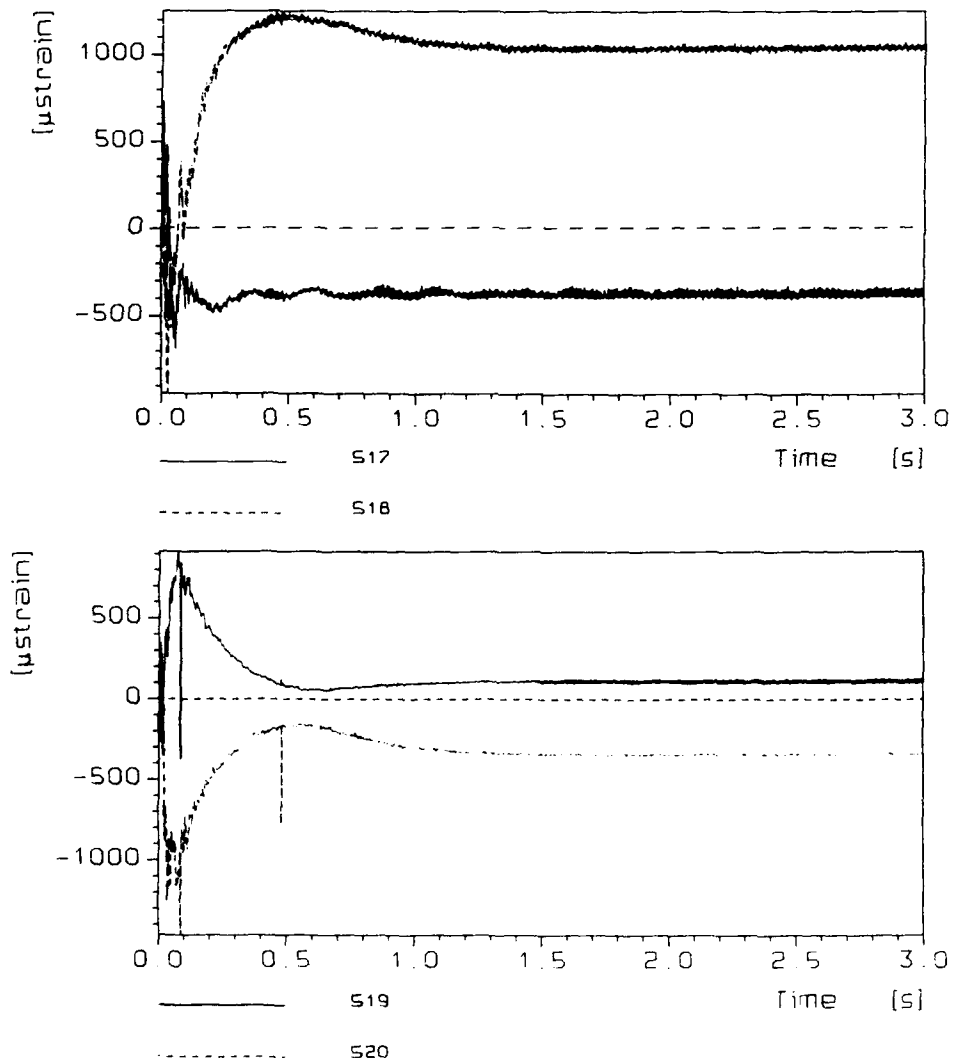

Figure 28 Strain gauge response S17 and S18, S19 and S20 (BHD 23)

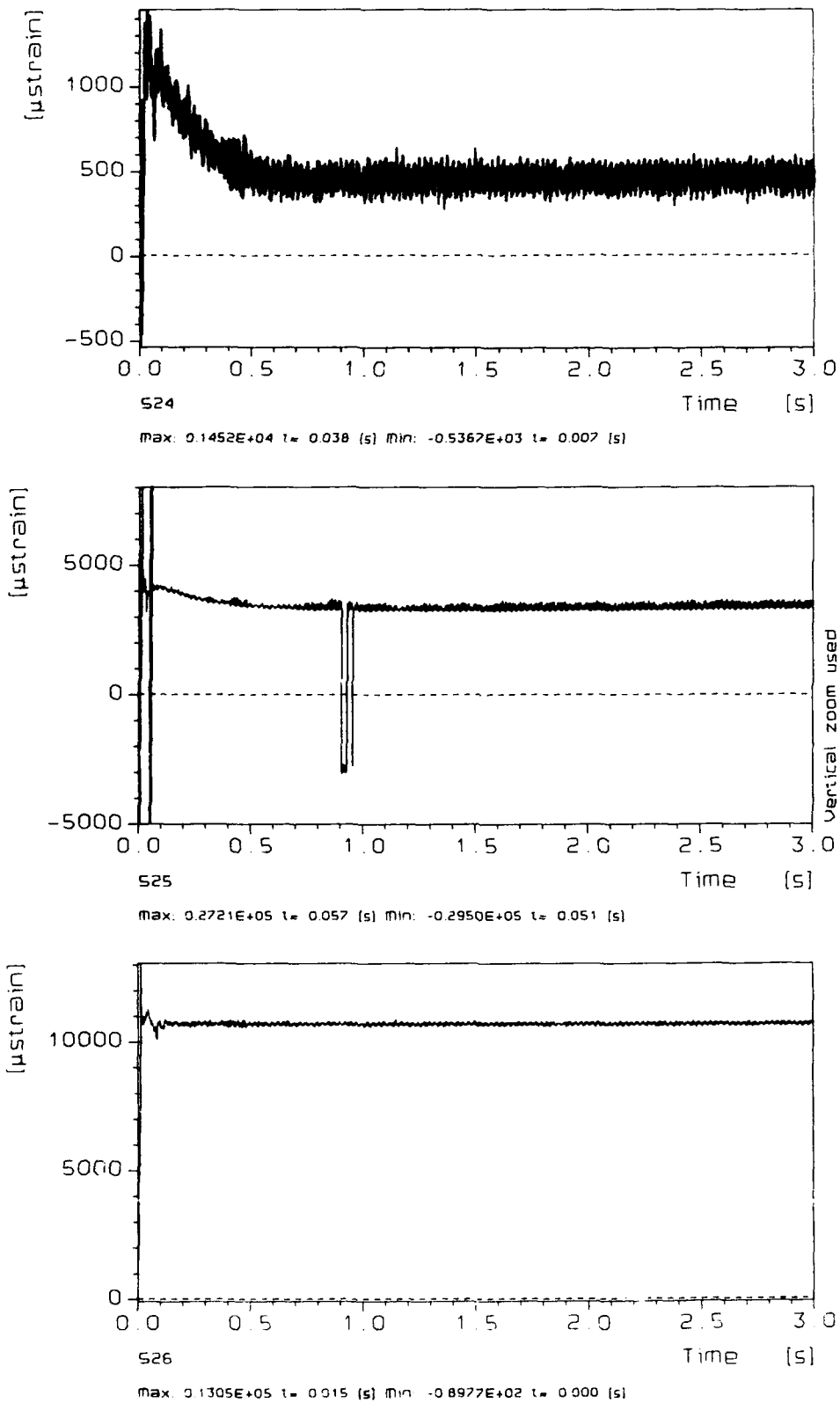

Figure 29 Strain gauge response S24, S25, S26 (floor of officers' compartment)

## 6 ACCELERATION MEASUREMENTS

### 6.1 Position of the accelerometers

During the 3 and 12 kg TNT experiment, seven accelerometers were used, mounted on the H and J deck, respectively. The locations of the accelerometers are summarized in Table 10 and shown schematically in Figures 30, 31 and 32. In these figures, the direction of sensitivity of the transducers is denoted by the length axis of the blocks ■.

Table 10 Position of the accelerometers

Device	Mounting position		
A5	ceiling	J-deck	74 cm BHD 45, on PS girder
A6	floor	J-deck	75 cm from BHD 45
A8	ceiling	J-deck	284 cm from BHD 23, on PS girder
A9	see A5	horizontal measuring direction	
A10	see A8	horizontal measuring direction	
A11	75 cm above floor,	60 cm from BB	
A13	119 cm above floor,	on stiffener near chartroom	

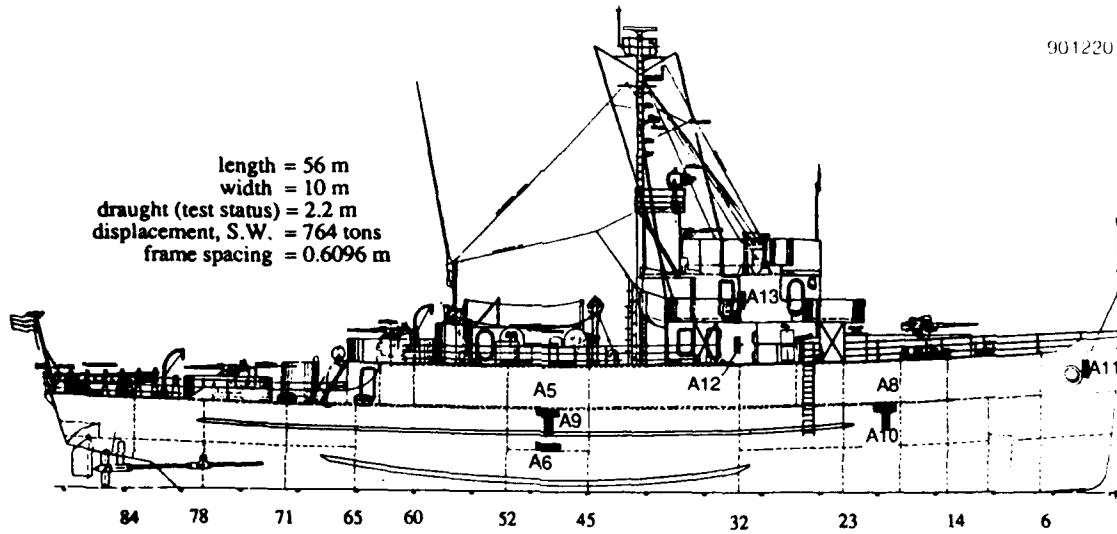

Figure 30 Schematic illustration of the positions of the accelerometers

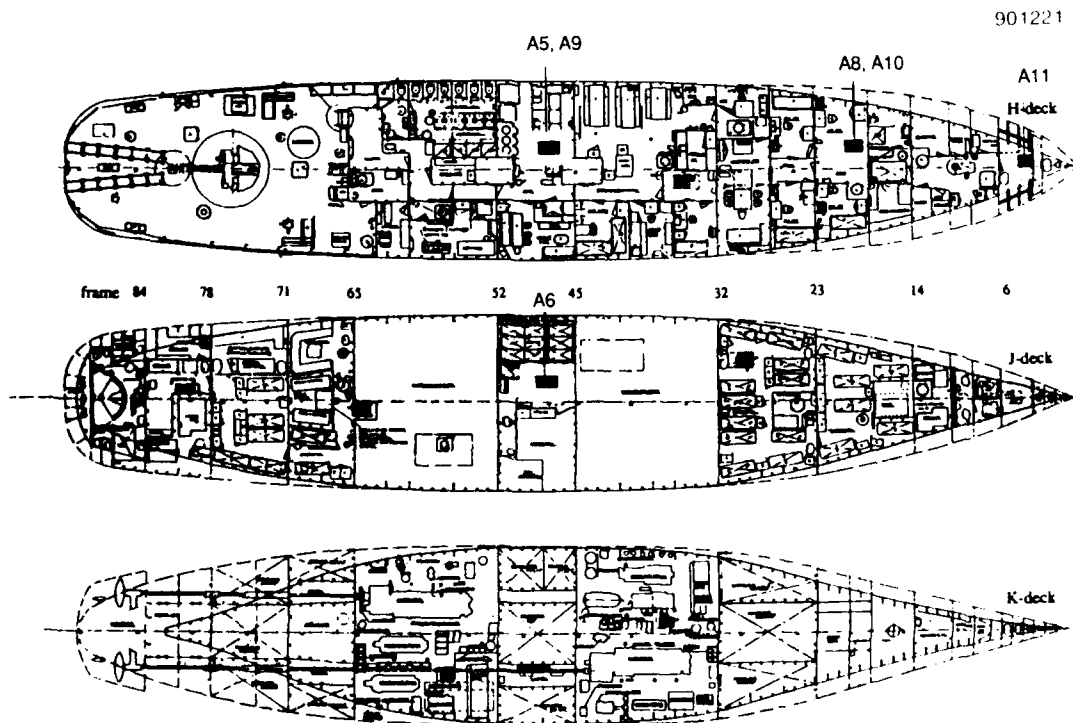

Figure 31 Schematic illustration of the positions of the accelerometers

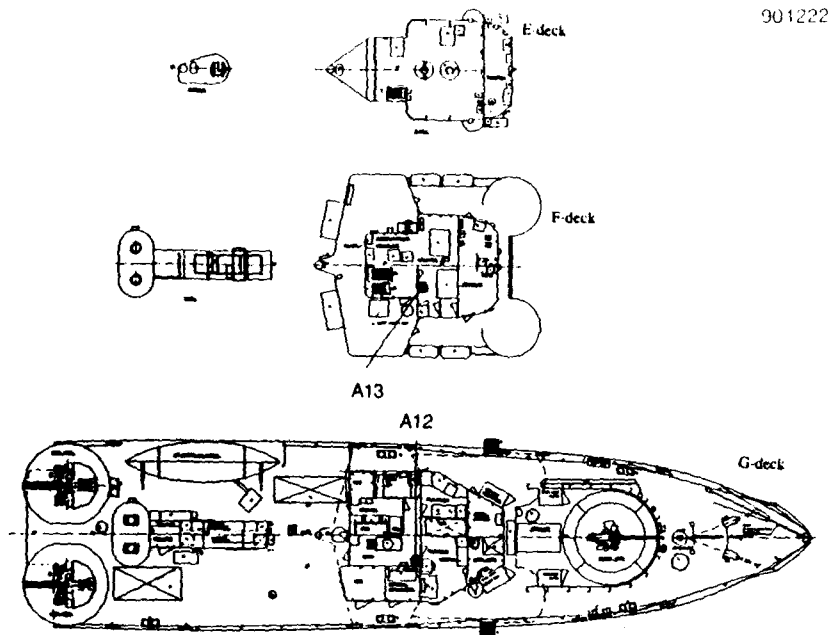

Figure 32 Schematic illustration of the positions of the accelerometers

## 6.2 Discussion of the acceleration measurement

The results of the measurements are shown in Figures 33-39. A distortion of the acceleration signals with a 50 Hz signal was removed. Additionally, a third order low pass Butterworth filter (1.5 kHz) was used to diminish the influence of the higher frequencies.

Integration of the recordings with respect to the time results in the velocity and displacement signals, which are also shown in these figures. Drift correction was applied as indicated in the legends. Drift however seems to be still noticeable in some of the displacement signals.

The behaviour of transducer A8 is ambiguous for the time period 50-60 ms, while the start of transducer A10 seems to be not realistic. During this experiment, the A11 and A13 transducers recorded realistic signals up to 40 ms, in contrast with the 3 kg TNT experiment.

It is obvious that the presented velocity and displacement signals should be handled with care due to the rather ad hoc applied signal analysis correction techniques.

The (undamped) shock spectra are also included in this report in Figures 40-46. The positive and negative residual shock spectra are identical because damping was omitted.

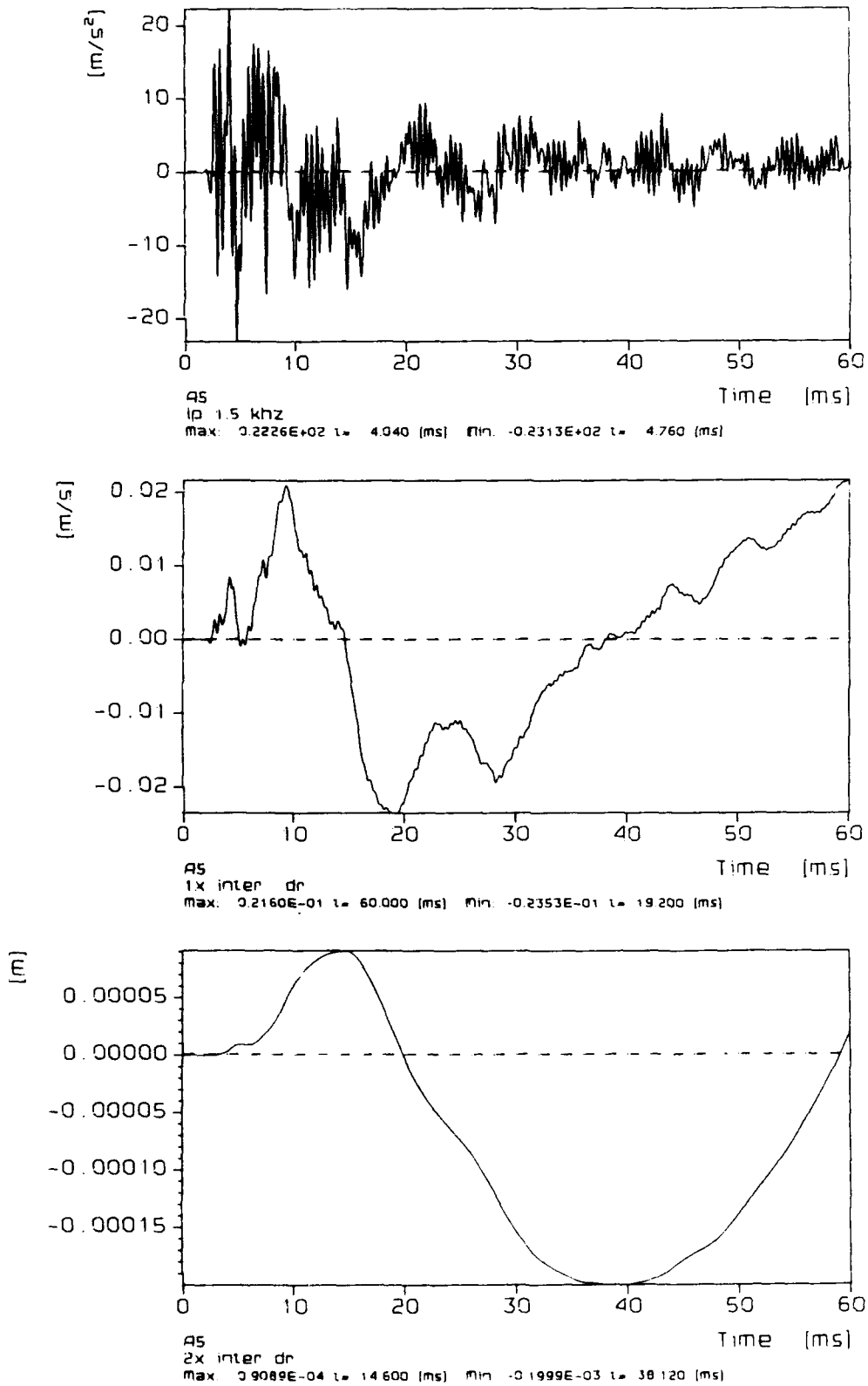

Figure 33 Accelerometer A5

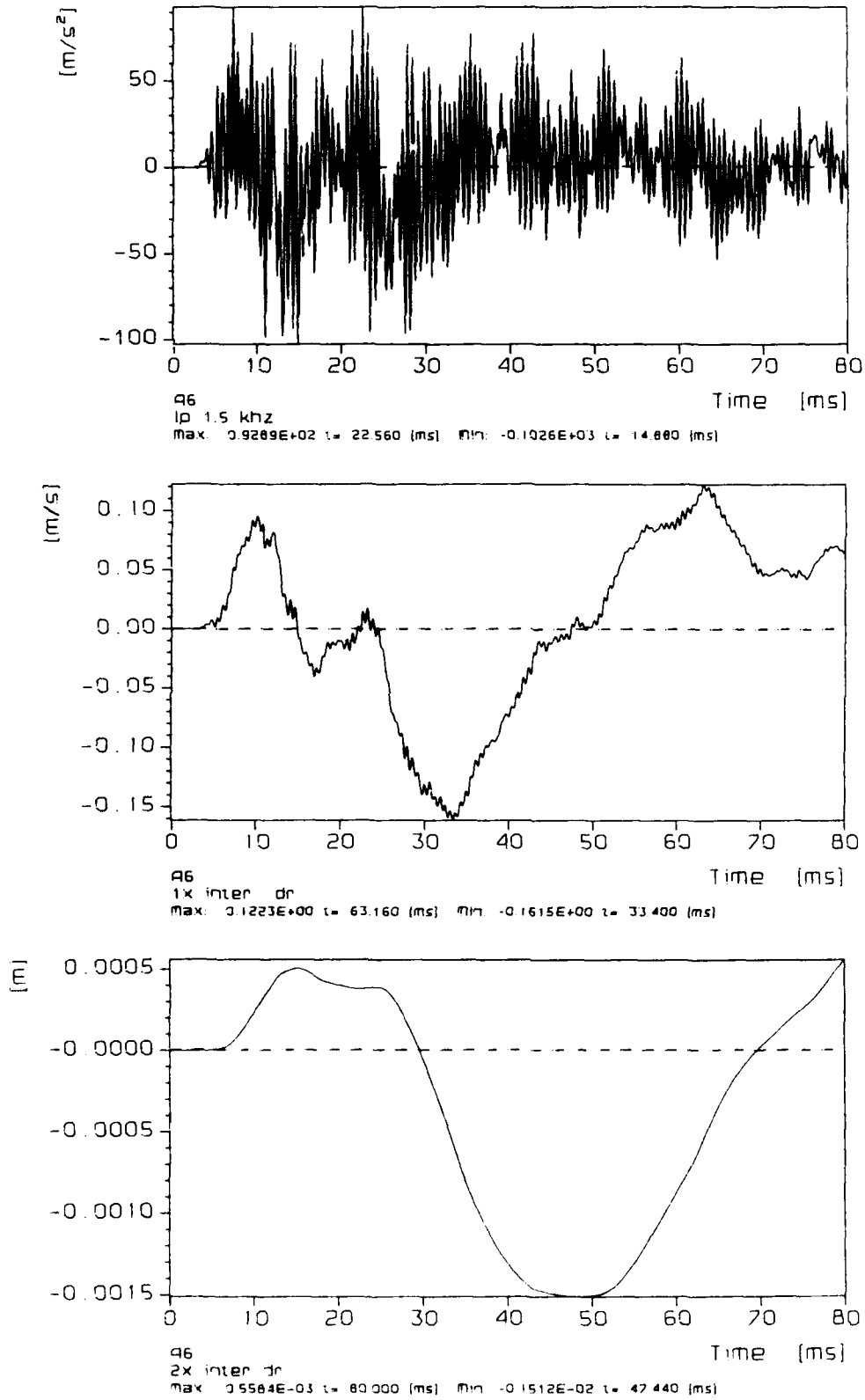

Figure 34 Accelerometer A6



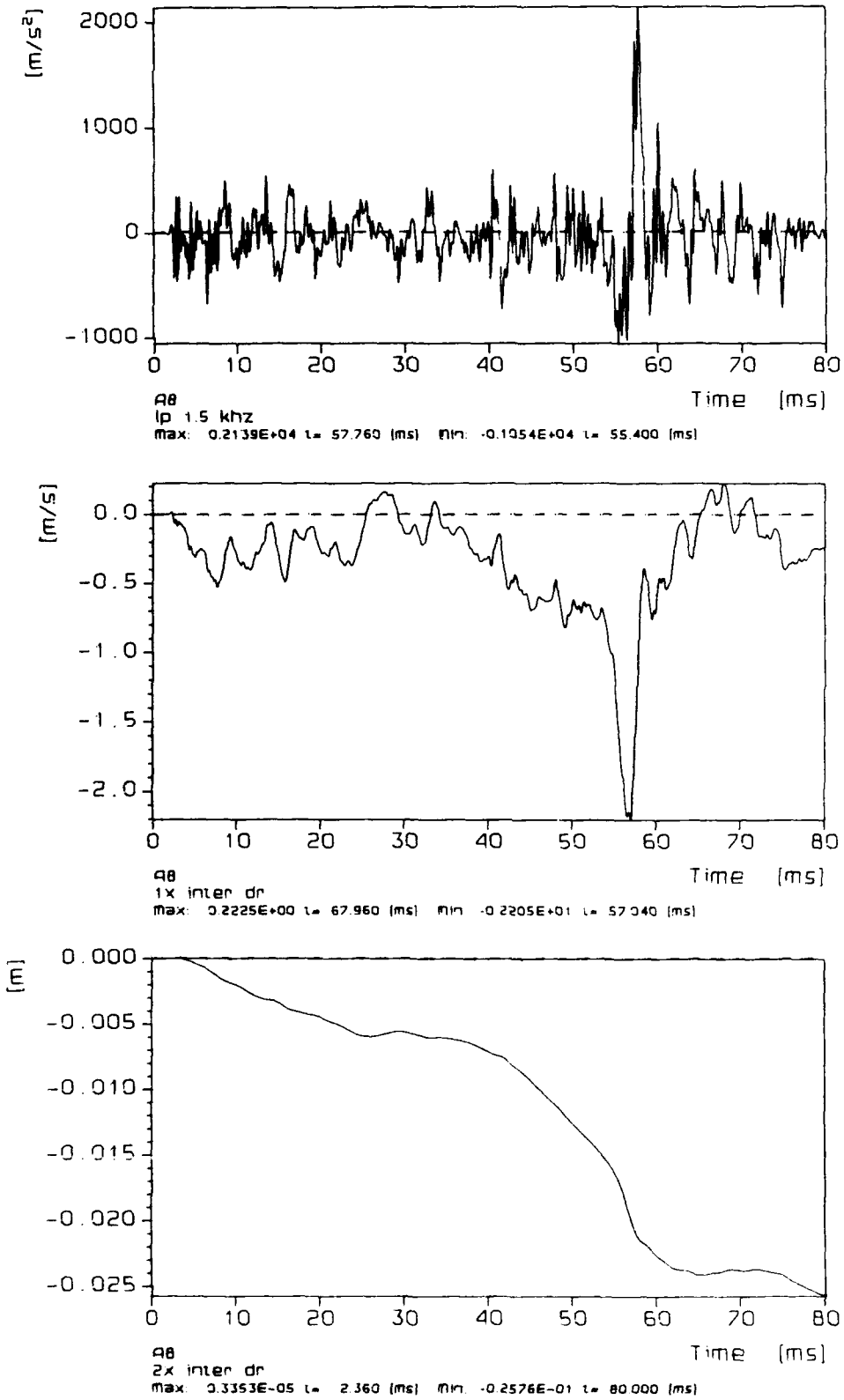

Figure 35 Accelerometer A8

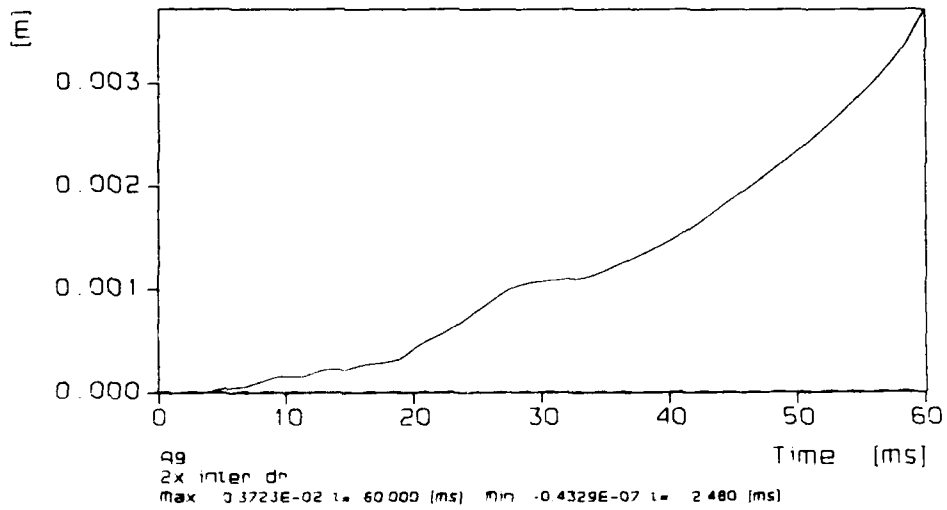
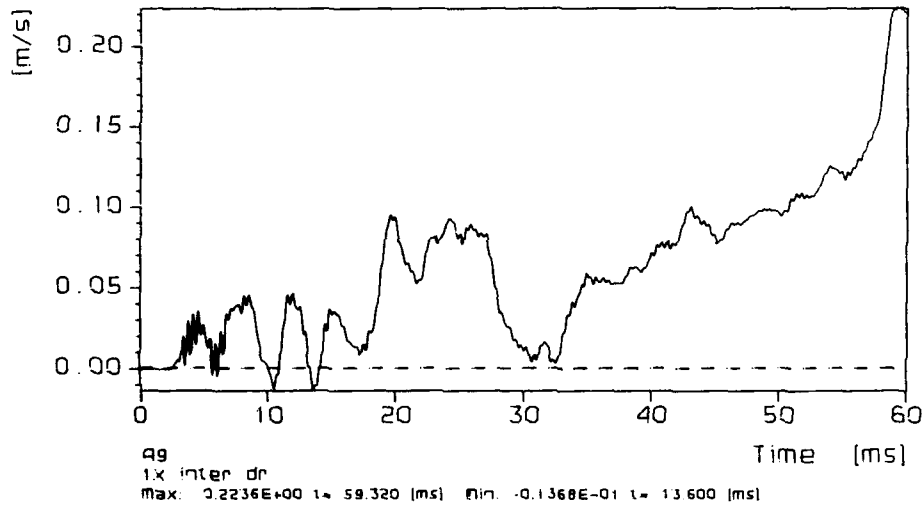
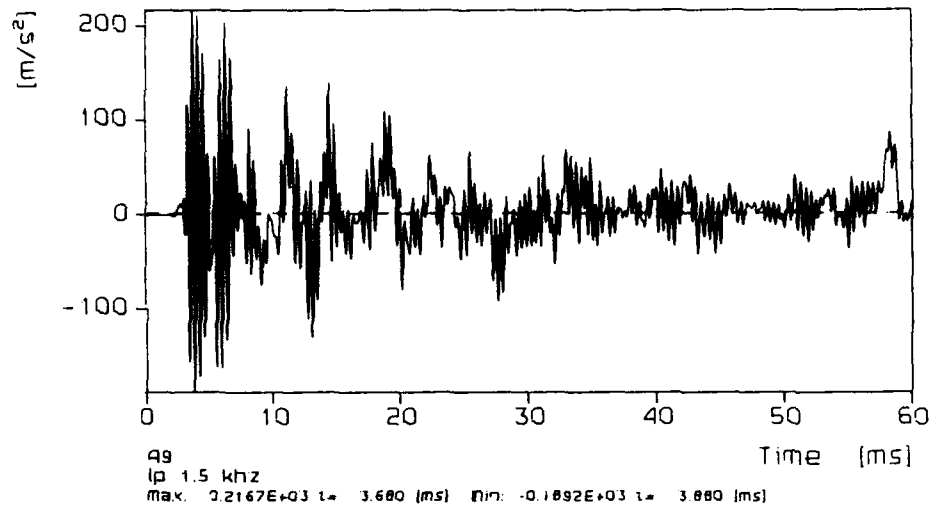

Figure 36 Accelerometer A9

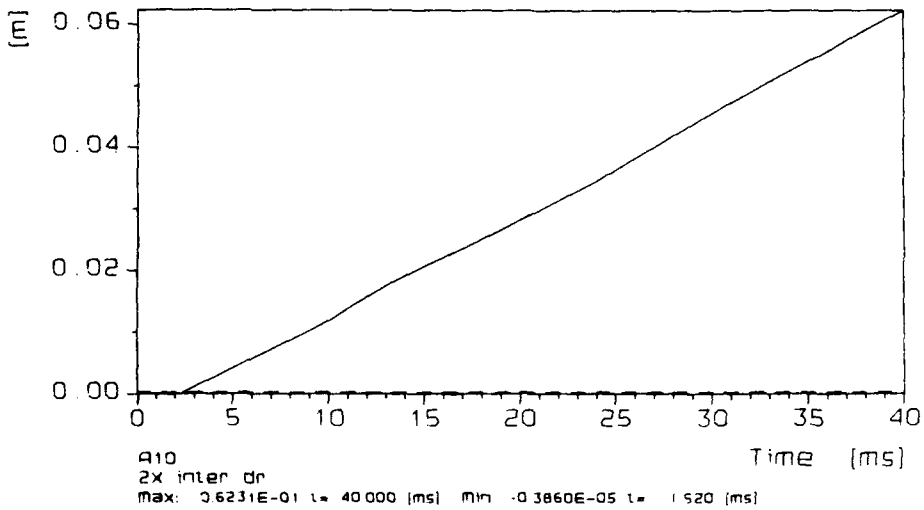
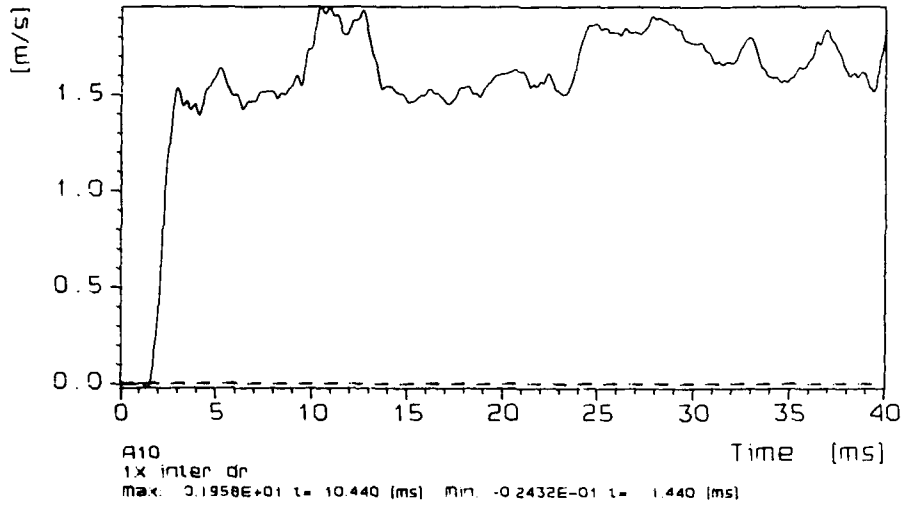
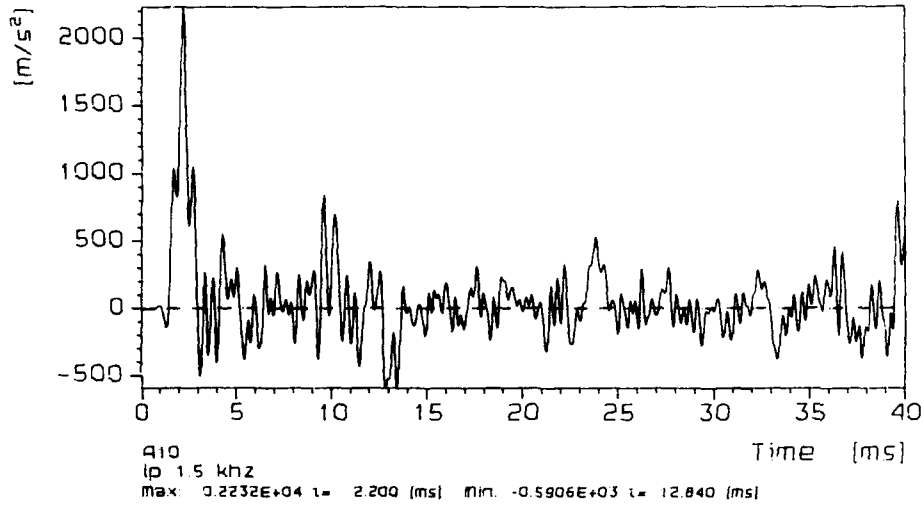

Figure 37 Accelerometer A10

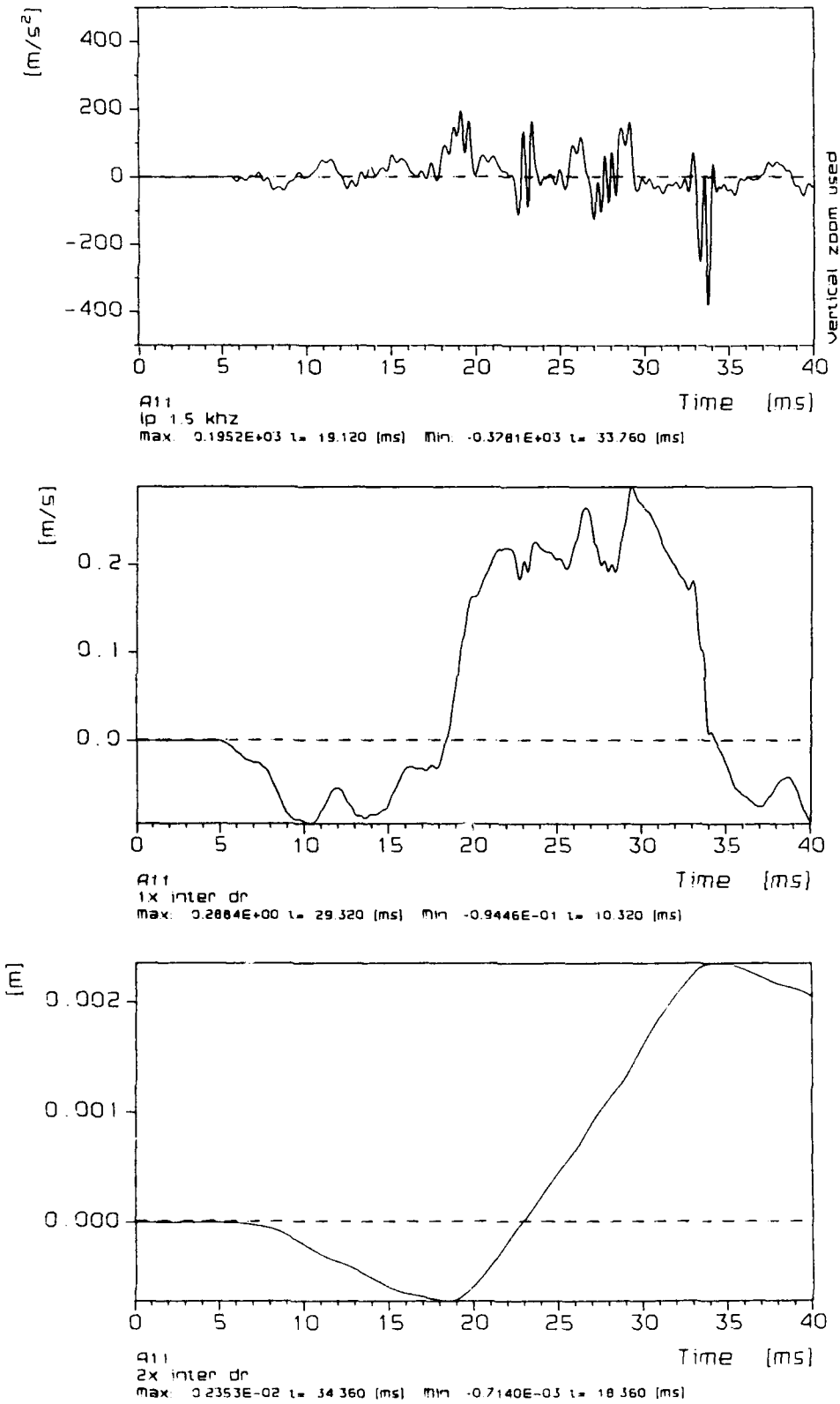

Figure 38 Accelerometer A11

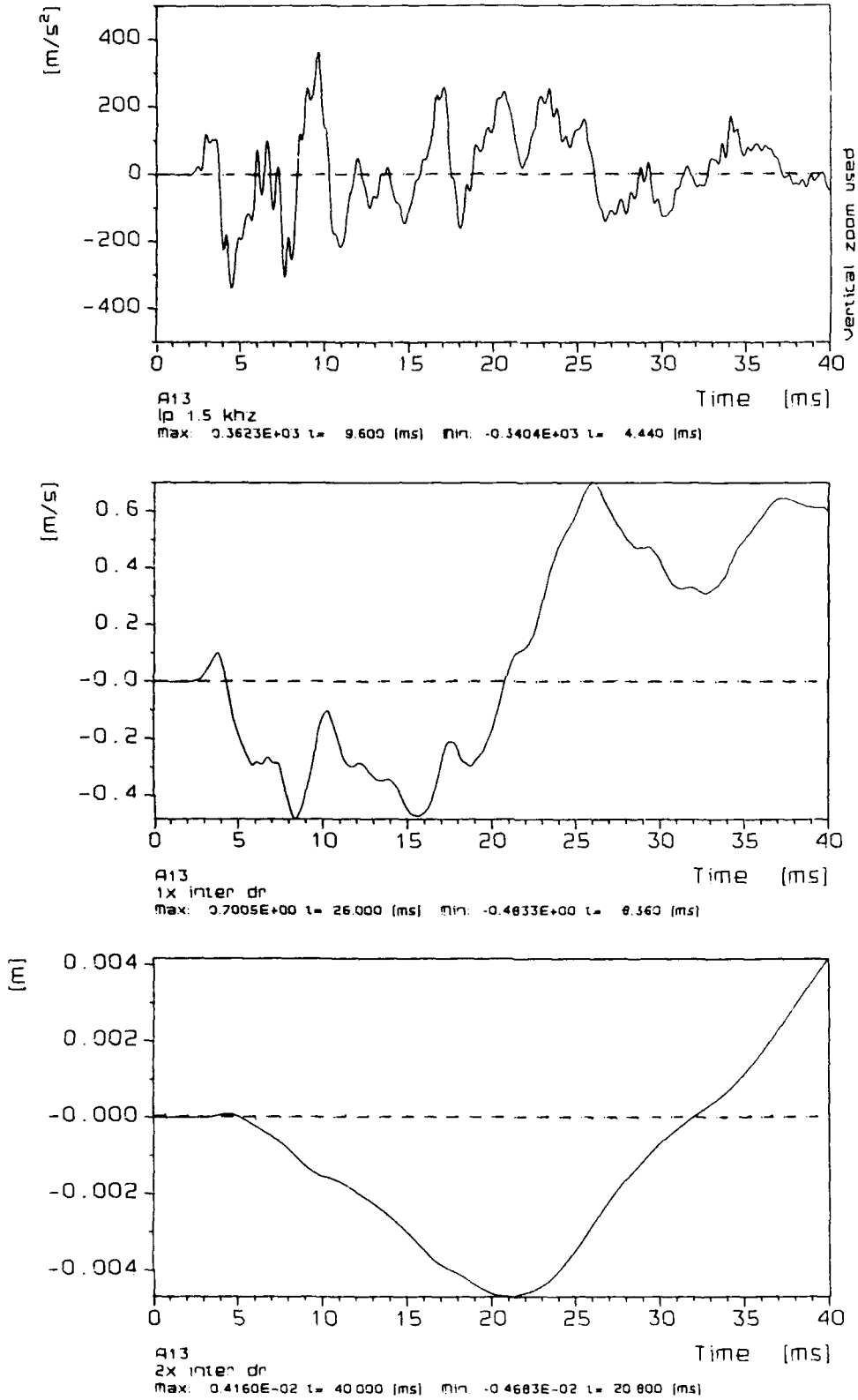

Figure 39 Accelerometer A13

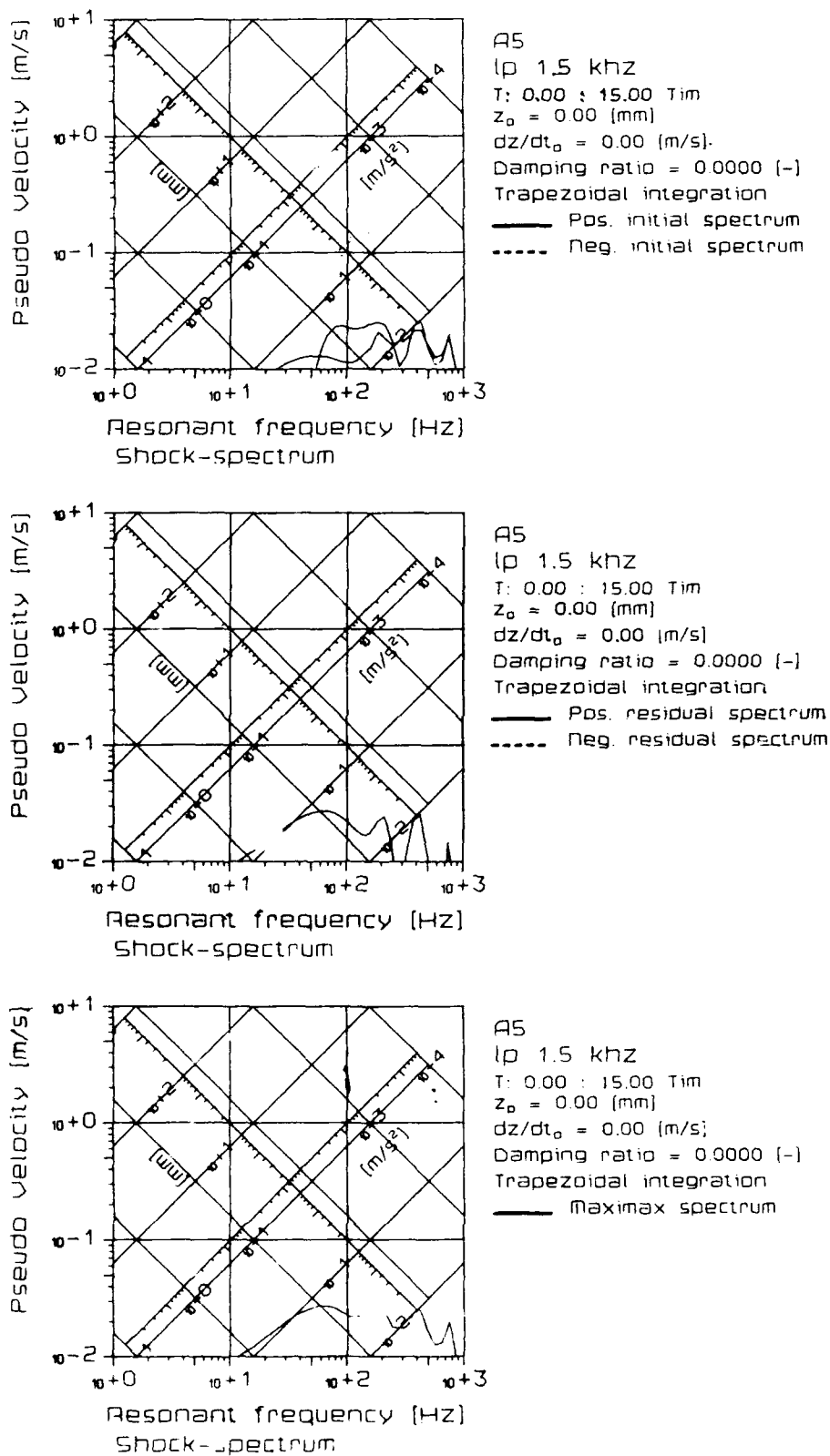

Figure 40 Shock spectra of accelerometer A5

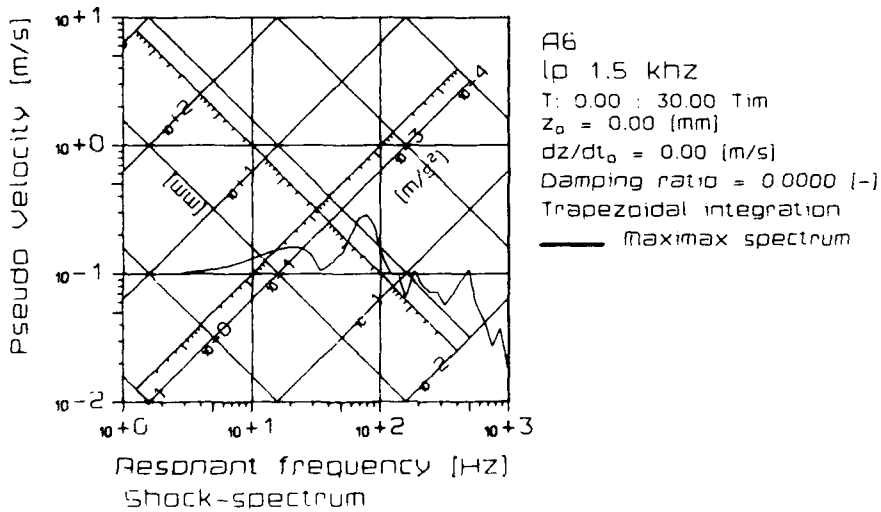
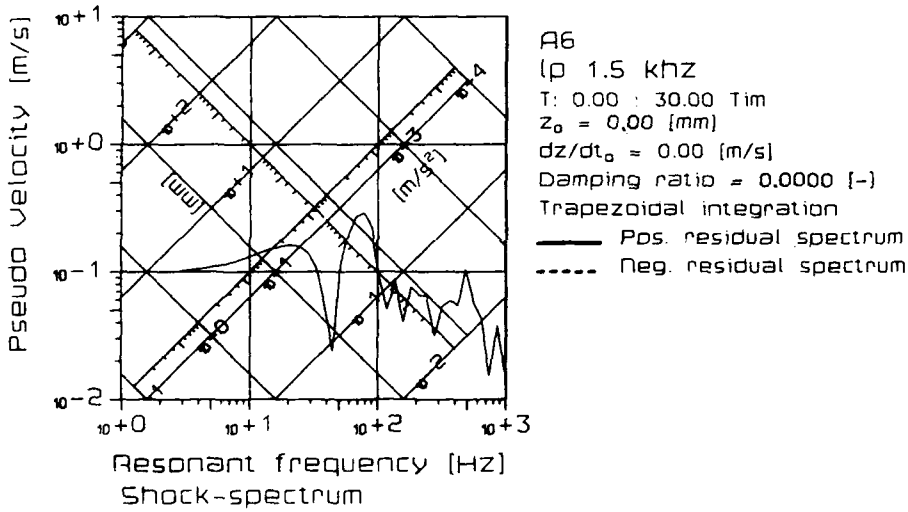
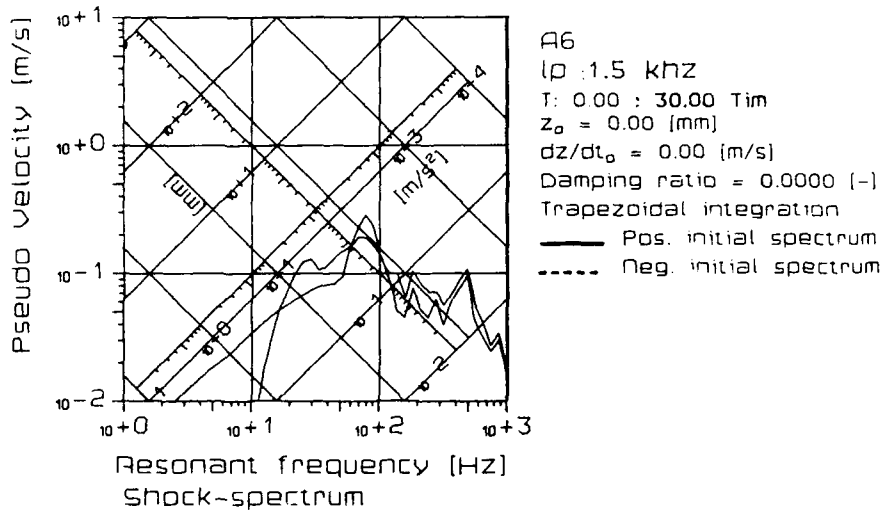

Figure 41 Shock spectra of accelerometer A6

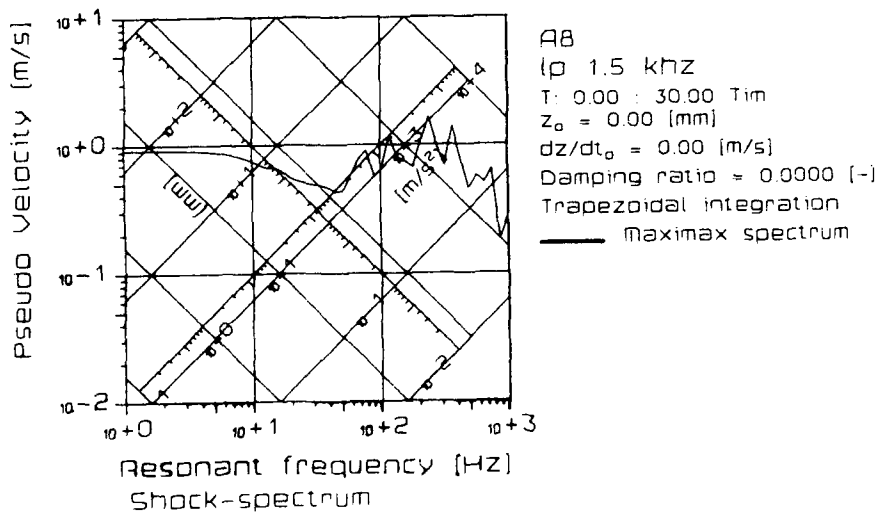
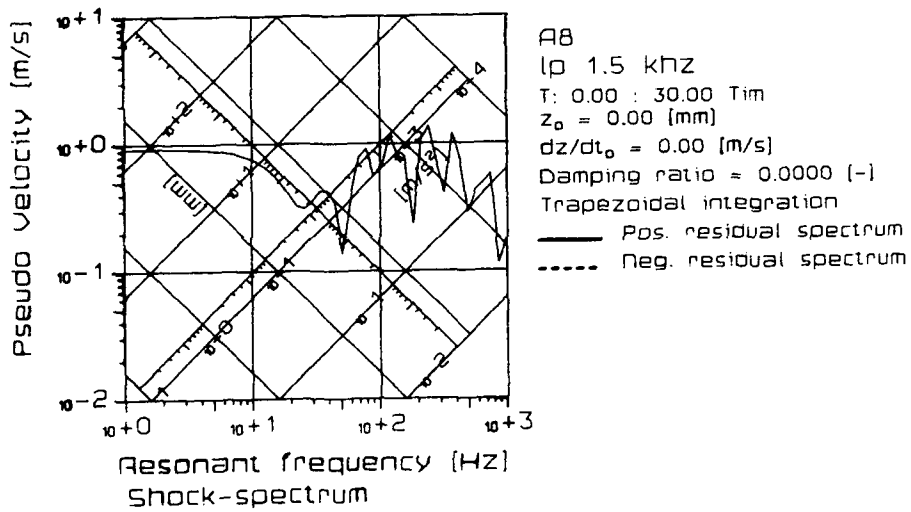
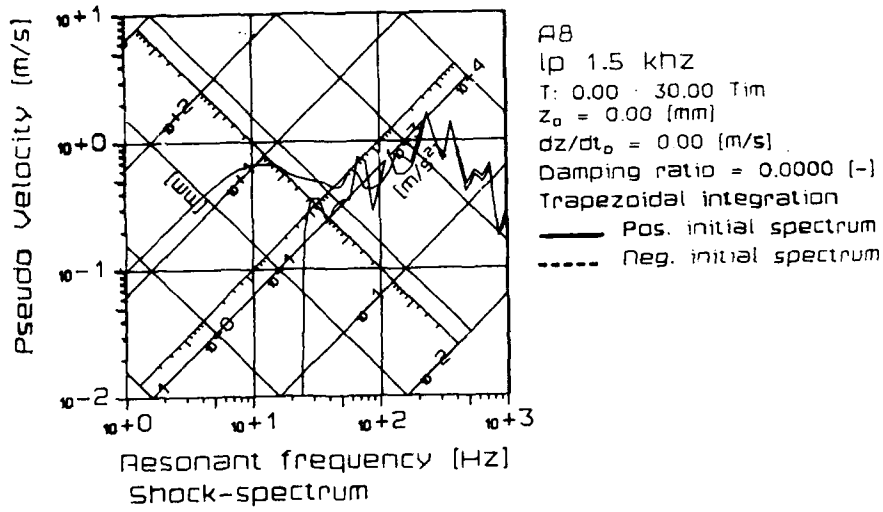

Figure 42 Shock spectra of accelerometer A8



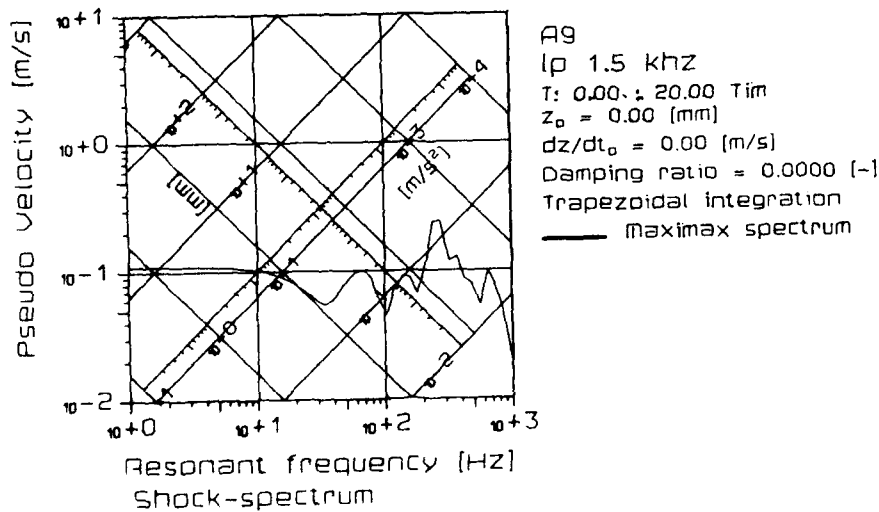
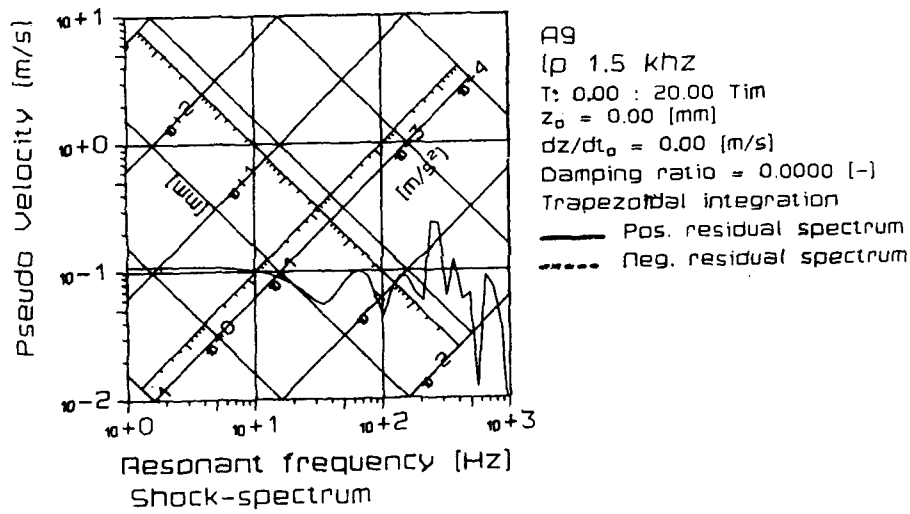
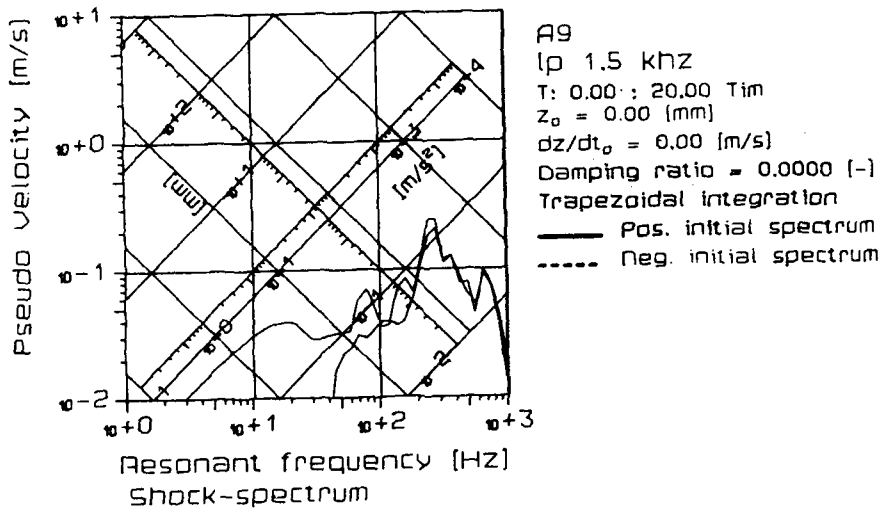

Figure 43 Shock spectra of accelerometer A9

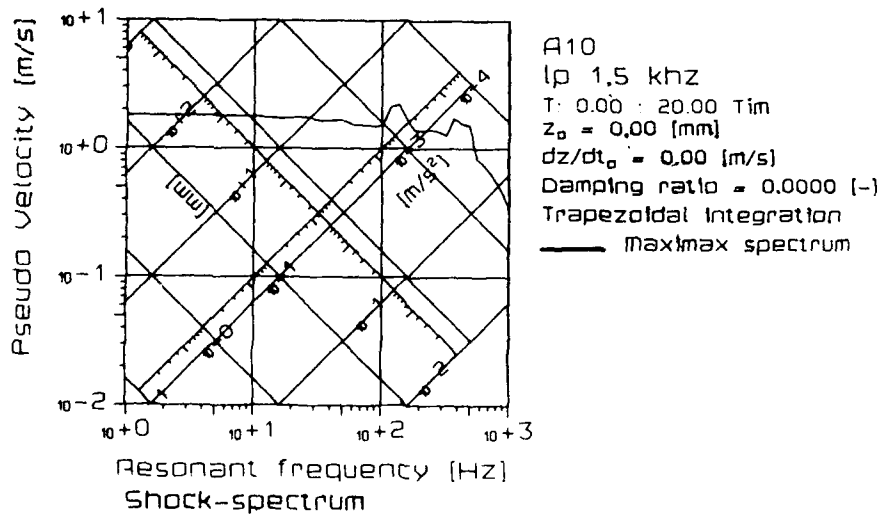
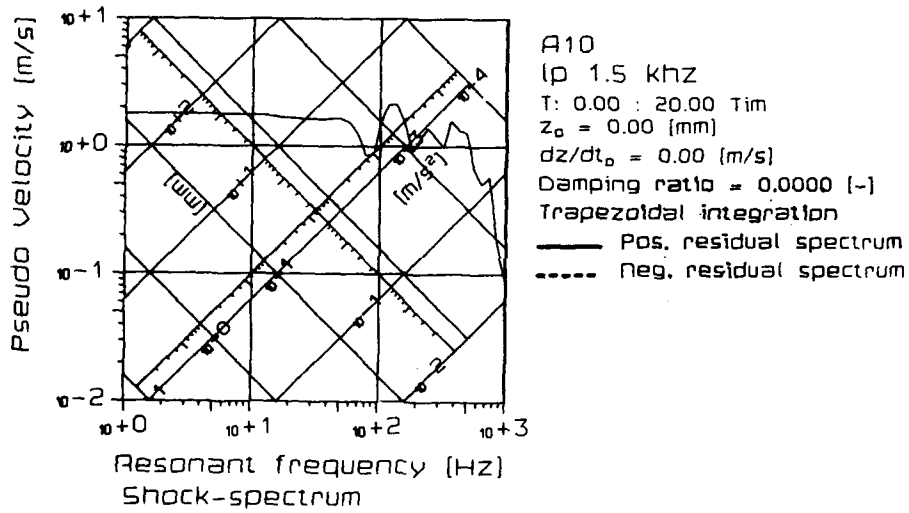
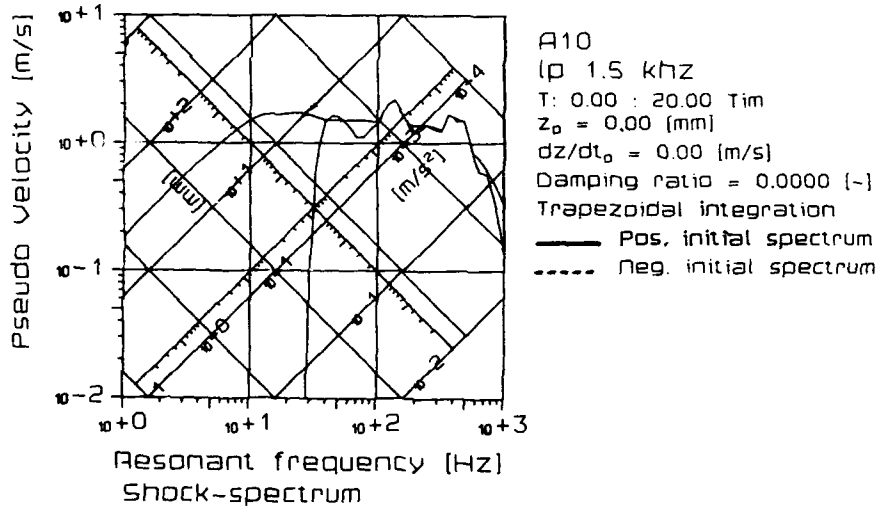

Figure 44 Shock spectra of accelerometer A10

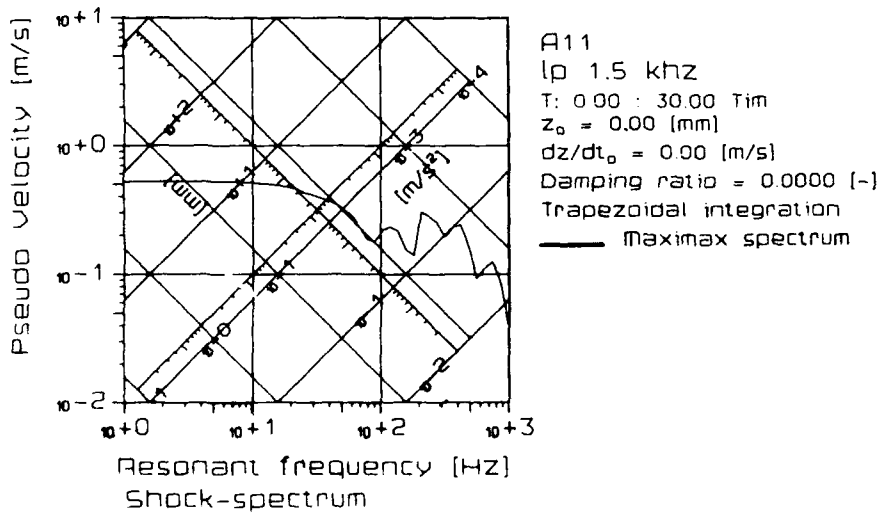
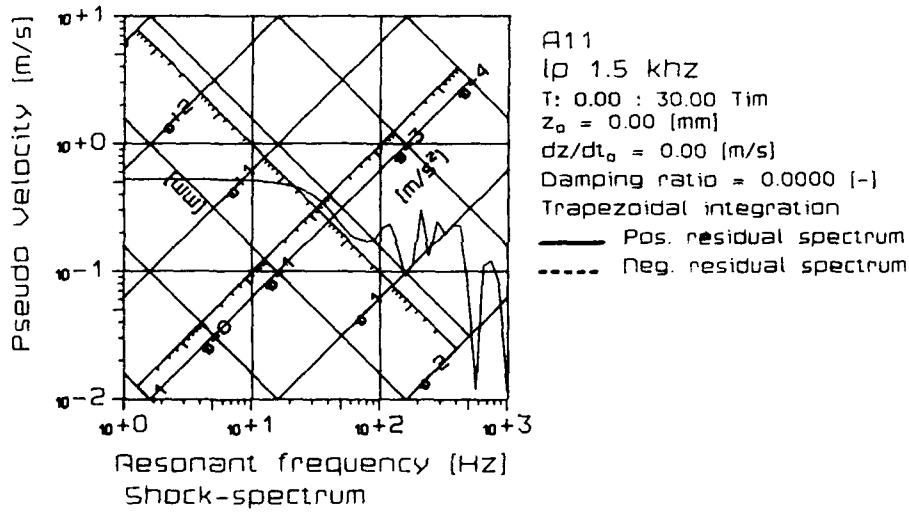
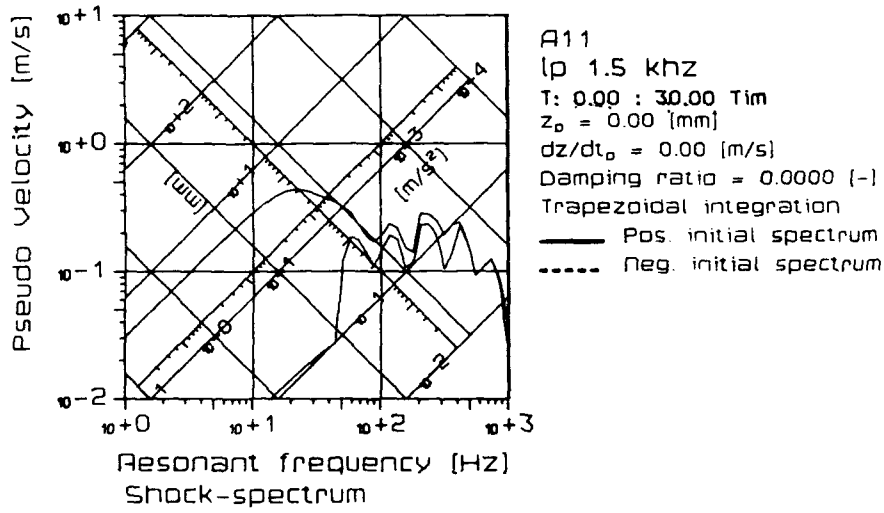

Figure 45 Shock spectra of accelerometer A11

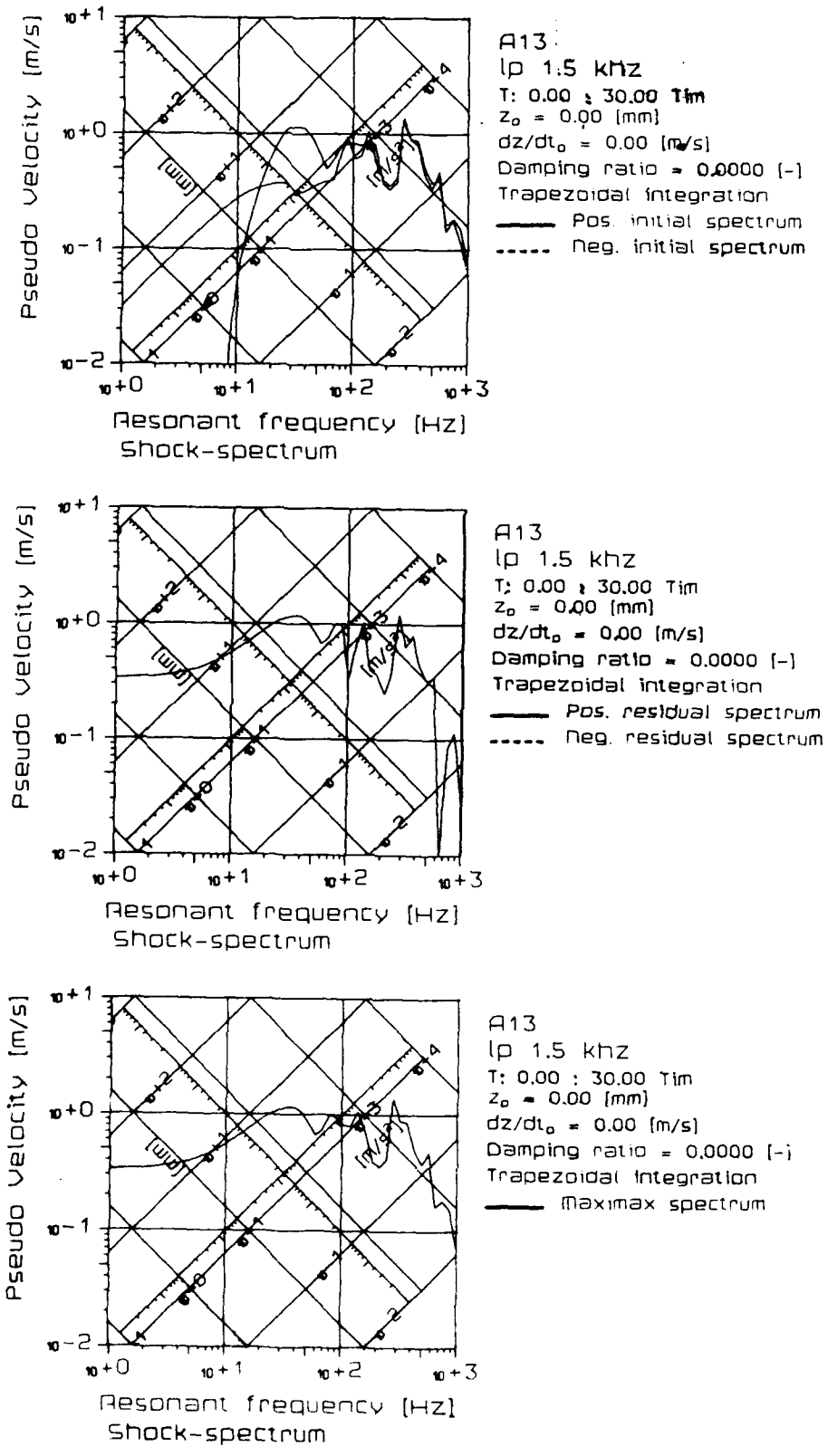

Figure 46 Shock spectra of accelerometer A13

## 7 TEMPERATURE MEASUREMENTS

## 7.1 Position of the temperature transducers

During the experiment, one temperature measurement was performed. The location of the temperature measurement is given in Table 11 and shown schematically in Figure 47.

Table 11 Position of the temperature transducer

Device	Height	Position
T1	113 cm	115 cm from BHD 14 on ASDIC room in the vicinity of Q5

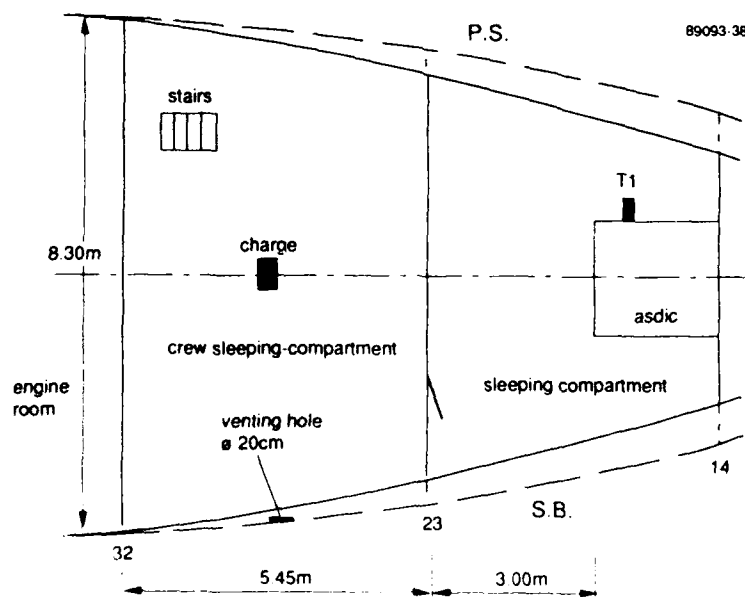

Figure 47 Schematic illustration of the position of the temperature transducer

## 7.2 Discussion of the temperature measurement

In Figure 48, the registered temperature increase signal is shown. It appeared that the temperature measurement resulted in a reliable signal, although the transducer malfunctioned during the 3 kg TNT experiment earlier that day.

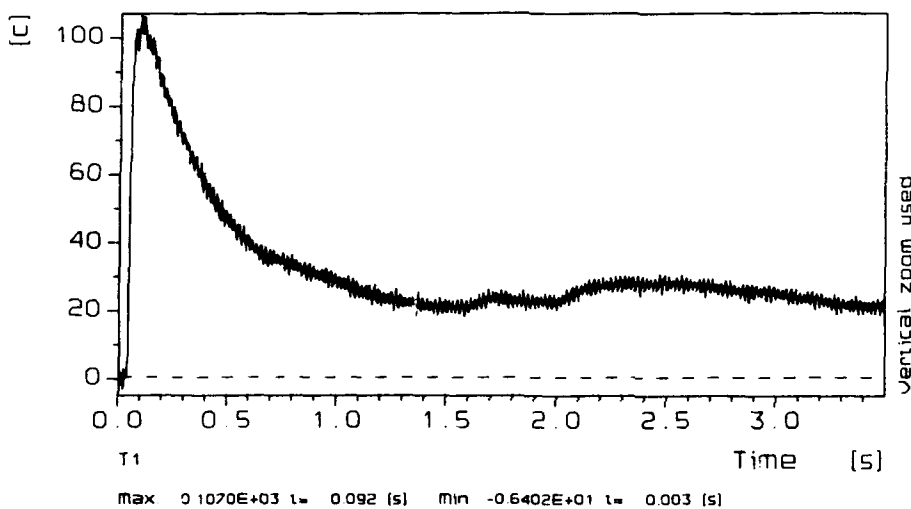

Figure 48 Temperature behaviour, relative to the ambient temperature

## 8 BREAKWIRES

### 8.1 Position of the breakwires

In order to determine the possible moment of collapse of the watertight door in BHD 23, two breakwires were used. They were mounted behind the watertight door, one third and two-thirds of the way up the door. These wires were outside the experiment compartment.

The positions of the breakwires used are shown schematically in Figure 49.

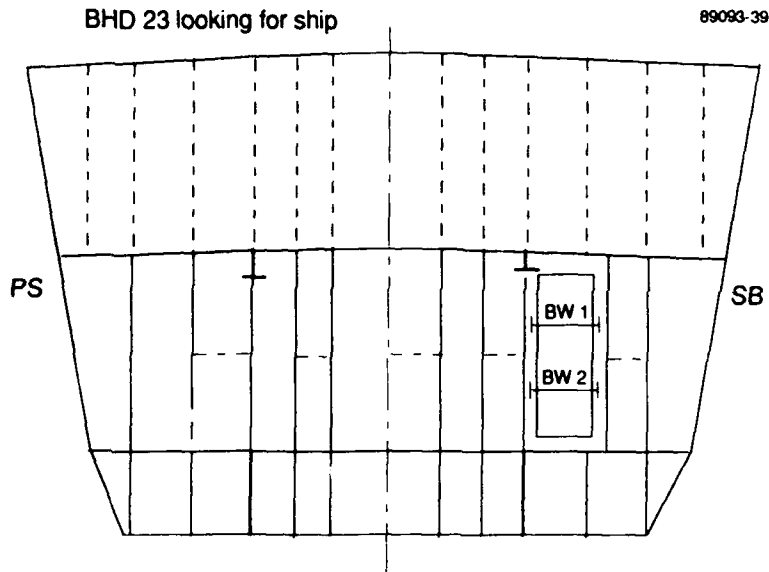

Figure 49 Schematic illustration of the breakwire positions in BHD 23

## 8.2 Discussion of the breakwire measurement

In Figure 50, the registered signal BW1 is shown. It must be noted that the door collapsed during this experiment. Unfortunately the BW2 signal malfunctioned during the experiment.

The breakwire BW1 responded after 1.5 ms, or even 1.7 ms. Comparing these times with the symmetrically placed B4 and B5 transducers (arrival time 2.6 and 4.3 ms) indicates an early reaction time. From this it must be concluded that the breakwire reacts again on the arrival of the shock wave through the decks, etc..

The breakwire measurement method used, breakwires in combination with microswitches, is too sensitive to shock.

Regarding the fall in the quasi-static pressure signals Q1 and Q2 at about 10-15 ms, and the start of the quasi-static pressure signals in the adjacent compartments after 10-15 ms, the collapse of the door and BHD 23 must have also taken place during this time period.

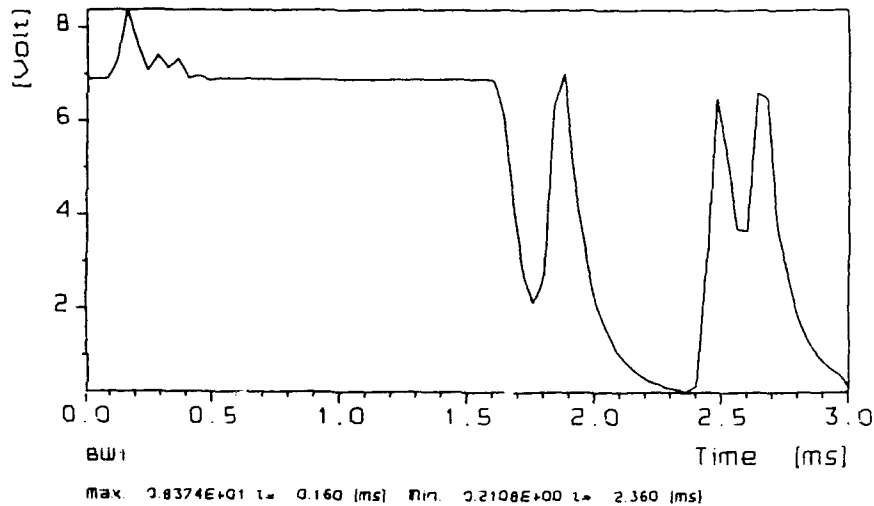

Figure 50 The registered breakwire signal

## 9 CONCLUSION

During the Wolf Phase II trial, a number of instrumented experiments in the crew forward and the crew aft sleeping compartment were performed. During the instrumented experiments, special attention was paid to the measurement of the blast, quasi-static pressure, strain, acceleration, temperature and the possible moment of collapse of the watertight door(s).

This report deals with the 12 kg TNT experiment in the crew forward sleeping compartment, which was preceded by the 3 kg TNT experiment earlier that day. The damage to the compartment as well as to some of the transducers could not be repaired between the experiments. It is for this reason that some of the transducers did not function (well) during this experiment.

The interpretation of these recordings will be part of the van Erkel (1992) reports.

The blast transducers recorded realistic signals up to 15 ms. It must be noted that theoretical predictions of peak pressure and arrival time, based on a centrally ignited, spherical charge, do not correspond well with the recordings. The geometry of the charge, as well as the way the charge is



ignited, appeared to be very important. However, an acceptable correspondence is found with the theoretical predictions based on a cylindrical charge.

The quasi-static pressure measurements in the experiment compartment correspond with the theoretical predictions. From 10-15 ms up to 50 ms, these signals drop in favour of the rise in the quasi-static pressure in the adjacent compartments. From 50 ms the decay of the quasi-static pressure is very similar for the transducers in the experiment compartment and the adjacent compartments. From these measurements one may deduce that the walls probably collapsed during the first 15 ms after the charge ignited. The quasi-static pressure in the 'enlarged' compartment also compares well with the theoretical predictions.

Opposite strain measurements were depicted in one figure, enabling a better understanding of the physical phenomena. Several strain gauges malfunctioned during the recording period due to the destructive processes. The time-scales used in the figures are depicted by its malfunctioning. However, the initial parts of most signals seems to be reliable. The conclusions from these strain measurements concerning the collapse of the bulkhead compares well with the conclusions from the quasi-static pressure measurements.

The acceleration recordings showed a distortion of 50 Hz, which was removed before the signals were presented in this report. In addition, a low pass filtering was used to diminish the influence of higher frequencies.

Integration of the acceleration signals with respect to the time resulted in velocity and displacement signals. Drift correction was necessary. The resulting velocity and displacement signals should be handled with care due to the rather ad hoc applied signal analysis techniques. The (undamped) shock spectra of these recordings are included in this report.

In contrast with the previous 3 kg TNT experiment, the temperature measurement was of good quality and resulted in a reliable signal.

Determination of the moment of collapse of the watertight door in BHD 23 by breakwire measurement seems to be an inappropriate solution. The registered breakwire signals seem to indicate the moment of shock wave arrival. The breakwire/microswitch combination appears to be too sensitive to shock.

From the recordings as presented in this report, it may be concluded that the instrumented 12 kg TNT experiment in the crew forward sleeping compartment resulted in a valuable set of data which can be used to validate the prediction models. Notwithstanding the violence and demolition processes during these kind of experiments, the recordings are of good quality due to the special preparations, mounting techniques and protection methods applied.

## 10 AUTHENTICATION

The realization of the Wolf Phase II trial presented in this set of reports was achieved due to the effort of a number of technicians from the Explosion Prevention Group: Mr. M.W.L. Dirkse, Mr. Ph. van Dongen, Mr. R.M. van de Kastele and Mr. A.M. Steenweg who carried out the experiments and processed the results.

We would also like to acknowledge the supporting services of the Royal Netherlands Navy.

Date:

1 April 1992



J. Weerheijm  
(Project Manager)



Th.L.A. Verhagen  
(Author)

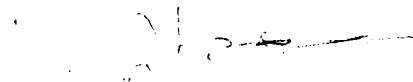

R.M. van de Kastele  
(Author)

## 11 REFERENCES

### 11.1 General references

**Baker, W.E.; Kulesz, J.J.; Westine, P.S.; Cox, P.A.; Wilbeck, J.S.**

**A manual for the prediction of blast and fragment loading on structures**  
Southwest Research Institute, San Antonio, Nov. 1980

**Baker, W.E.; Cox, P.A.; Westine, P.S.; Kulesz, J.J.; Strehlow, R.A.**

**Explosion hazards and evaluation fundamental studies in engineering 5**  
Elsevier Scientific Publishing Company, 1983

### 11.2 FRET reports

**Kastele, R.M. van de; Verhagen, Th.L.A.**

**Geïnstrumenteerde beproeving van het roefdierfregat "FRET"**  
Meetresultaten van de proef in het manschappen slaapverblijf op het voorschip  
PML - TNO, Rapport No. 1989-32 (in Dutch)

**Kastele, R.M. van de; Verhagen, Th.L.A.**

**Geïnstrumenteerde beproeving van het roefdierfregat "FRET"**  
Meetresultaten van de proef in het manschappen slaapverblijf op het achterschip  
PML - TNO, Rapport No. 1989-33 (in Dutch)

**Kastele, R.M. van de; Verhagen, Th.L.A.**

**Geïnstrumenteerde beproeving van het roefdierfregat "FRET"**  
Achtergrond informatie met betrekking tot gebruikte opnemers en bevestigingsmethoden  
PML - TNO, Rapport No. 1989-34 (in Dutch)

### 11.3 WOLF, phase I reports

**Kastele, R.M. van de; Zwaneveld, J.H.C.**

**Geïnstrumenteerde beproeving aan boord van fregat "WOLF"**  
Wolf I: Meetresultaten van de proeven in kabelgat/ankerlierruimte en onderofficiers-verblijf/kombuis  
PML - TNO, Rapport No. 1989-45 (in Dutch)

Kastele, R.M. van de; Zwaneveld, J.H.C.

Geïnstrumenteerde beproeving aan boord van fregat "WOLF"

Wolf I: Resultaten van de metingen verricht in de stuurhut en de wasplaats

PML - TNO, Rapport No. 1990-12 (in Dutch)

Kastele, R.M. van de

Geïnstrumenteerde beproeving aan boord van fregat "WOLF"

Wolf I: Achtergrond informatie met betrekking tot gebruikte opnemers en bevestigingsmethoden

PML - TNO, Rapport No. 1989-36 (in Dutch)

Zwaneveld, J.H.C.

Overpressure, blast, strain and accelerations in a ship compartment due to near external explosions

PML - TNO, Report No. 1989-18

#### 11.4            *WOLF, phase II reports*

Verhagen, Th.L.A.; Kastele, R.M. van de

Instrumented experiments aboard the frigate "WOLF"

Wolf II: Measurement results of the 2 kg TNT experiment in the crew aft sleeping compartment

PML - TNO, 1992-10

Verhagen, Th.L.A.; Kastele, R.M. van de

Instrumented experiments aboard the frigate "WOLF"

Wolf II: Measurement results of the 3 kg TNT experiment in the crew front sleeping compartment

PML - TNO, 1992-11

Verhagen, Th.L.A.; Kastele, R.M. van de

Instrumented experiments aboard the frigate "WOLF"

Wolf II: Measurement results of the 5.5 kg TNT experiment in the crew aft sleeping compartment

PML - TNO, 1992-12

Verhagen, Th.L.A.; Kastele, R.M. van de

Instrumented experiments aboard the frigate "WOLF"

Wolf II: Measurement results of the 12 kg TNT experiment in the crew front sleeping compartment

PML - TNO, 1992-13

Verhagen, Th.L.A.; Kastele, R.M. van de  
Instrumented experiments aboard the frigate "WOLF"  
Wolf II: Measurement results of the 15 kg TNT experiment in the crew aft sleeping compartment  
PML - TNO, 1992-14

Kastele, R.M. van de; Verhagen, Th.L.A.  
Instrumented experiments aboard the frigate "WOLF"  
Wolf II: Background information concerning the transducers and mounting methods used  
PML - TNO, 1992-15

11.5           Roofdier Blast damage reports

Erkel, A.G. van  
Blast tests on ship doors  
PML-TNO, 1990-31

Erkel, A.G. van  
Roofdier internal blast damage  
Part I: Bare charge experiments in the aft sleeping compartment  
PML-TNO, 1992-(to be published)

Erkel, A.G. van  
Roofdier internal blast damage  
Part II: Bare charge experiments in the front sleeping compartment  
PML-TNO, 1992-(to be published)

Erkel, A.G. van  
Roofdier internal blast damage  
Part III: Experiments with shells and asymmetrical located bare charges  
PML-TNO, 1992-(to be published)

Erkel, A.G. van  
Roofdier internal blast damage  
Part IV: lessons learned  
PML-TNO, 1992-(to be published)

# REPORT DOCUMENTATION PAGE

(MOD NL)

1. DEFENSE REPORT NUMBER (MOD-NL) TD91-2527	2. RECIPIENT'S ACCESSION NUMBER	3. PERFORMING ORGANIZATION REPORT NUMBER PML1992-13
4. PROJECT/TASK/WORKUNIT NO. 292489093	5. CONTRACT NUMBER A88/KM/419	6. REPORT DATE August 1992
7. NUMBER OF PAGES 68	8. NUMBER OF REFERENCES 20	9. TYPE OF REPORT AND DATES COVERED Final
10. TITLE AND SUBTITLE Instrumented experiments aboard the frigate "WOLF". Wolf II: Measurement results of the 12 kg TNT experiment in the crew aft sleeping compartment. (Geïstrumenteerde beproevingen aan boord van het fregat "WOLF". Wolf II: Meetresultaten van de 12 kg TNT beproeving van het manschappen slaapcompartiment op het achterschip.)		
11. AUTHOR(S) Th.L.A. Verhagen, R.M. van de Kastele		
12. PERFORMING ORGANIZATION NAME(S) AND ADDRESS(ES) TNO Prins Maurits Laboratory P.O. Box 45, 2280 AA Rijswijk, The Netherlands		
13. SPONSORING AGENCY NAME(S) AND ADDRESS(ES) DMKM P.O. Box 20702, 2500 ES The Hague		
14. SUPPLEMENTARY NOTES		
15. ABSTRACT (MAXIMUM 200 WORDS (1044 BYTE))  Within the framework of the research into the vulnerability of ships, an experimental investigation took place in 1989 aboard the frigate "WOLF" of the "Roofdierklasse" (PCE 1604 class) (Wolf, Phase II).  In this report recordings of an instrumented experiment in the crew aft sleeping compartment are presented.  During this experiment, a non-fragmenting charge of 12 kg TNT was initiated.		
16. DESCRIPTORS Frigates Vulnerability TNT Explosion Effects Blast Measurement		IDENTIFIERS Pressure Measurement Strain Measurement Accelerometers Temperature Measurement
17A. SECURITY CLASSIFICATION (OF REPORT) UNCLASSIFIED	17B. SECURITY CLASSIFICATION (OF PAGE) UNCLASSIFIED	17C. SECURITY CLASSIFICATION (OF ABSTRACT) UNCLASSIFIED
18. DISTRIBUTION AVAILABILITY STATEMENT Unlimited Distribution		17D. SECURITY CLASSIFICATION (OF TITLES) UNCLASSIFIED

## DISTRIBUTION LIST

- 1 DWOO
- 2 HWO-KL
- 3 HWO-KLu
- 4 HWO-KM
- 5/7 TDCK
- 8/11 Ministerie van Defensie  
DMKM, Afd. Scheepsbouw
- 12 Hoofddirecteur DO-TNO
- 13 Lid Instituuts Advies Raad PML  
Prof. drs. P.J. van den Berg
- 14 Lid Instituuts Advies Raad PML  
Prof. Ir. M.A.W. Scheffelaar
- 15 Lid Instituuts Advies Raad PML  
Prof. Ir. H. Wittenberg
- 16 PML-TNO, Directeur Programma; daarna reserve
- 17/21 PML-TNO, Secretariaat Divisie 2, Groep Explosiepreventie en -bescherming
- 22/24 PML-TNO, Secretariaat Divisie 3, Groep Wapeneffectiviteit
- 25 PML-TNO, Documentatie
- 26 PML-TNO, Archief