

AD-A256 537

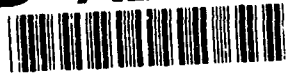

2

NAVAL POSTGRADUATE SCHOOL Monterey, California



OTIC
OCT 23 1992
E D

THESIS

CONCEPTS AND ISSUES FOR SYSTEMS
INTEGRATION OF U.S. AIR FORCE
DEPLOYABLE COMMUNICATIONS

by

Michael A. Cervi

June, 1992

Co-Advisor:
Co-Advisor:

Dan C. Boger
Carl R. Jones

Approved for public release; distribution is unlimited.

92-27962



251450

10519

92

REPORT DOCUMENTATION PAGE			
1a. REPORT SECURITY CLASSIFICATION UNCLASSIFIED		1b. RESTRICTIVE MARKINGS	
2a. SECURITY CLASSIFICATION AUTHORITY		3. DISTRIBUTION/AVAILABILITY OF REPORT Approved for public release; distribution is unlimited.	
2b. DECLASSIFICATION/DOWNGRADING SCHEDULE			
4. PERFORMING ORGANIZATION REPORT NUMBER(S)		5. MONITORING ORGANIZATION REPORT NUMBER(S)	
6a. NAME OF PERFORMING ORGANIZATION Naval Postgraduate School	6b. OFFICE SYMBOL (If applicable) 55	7a. NAME OF MONITORING ORGANIZATION Naval Postgraduate School	
6c. ADDRESS (City, State, and ZIP Code) Monterey, CA 93943-5000		7b. ADDRESS (City, State, and ZIP Code) Monterey, CA 93943-5000	
8a. NAME OF FUNDING/SPONSORING ORGANIZATION	8b. OFFICE SYMBOL (If applicable)	9. PROCUREMENT INSTRUMENT IDENTIFICATION NUMBER	
8c. ADDRESS (City, State, and ZIP Code)		10. SOURCE OF FUNDING NUMBERS	
		Program Element No.	Project No.
		Task No.	Work Unit Accession Number
11. TITLE (Include Security Classification) Concepts and Issues for Systems Integration of U.S. Air Force Deployable Communications			
12. PERSONAL AUTHOR(S) Michael A. Cervi			
13a. TYPE OF REPORT Master's Thesis	13b. TIME COVERED From To	14. DATE OF REPORT (year, month, day) June 1992	15. PAGE COUNT 105
16. SUPPLEMENTARY NOTATION The views expressed in this thesis are those of the author and do not reflect the official policy or position of the Department of Defense or the U.S. Government.			
17. COSATI CODES		18. SUBJECT TERMS (continue on reverse if necessary and identify by block number)	
FIELD	GROUP	SUBGROUP	
		Deployable communications, tactical communications, theater battle management, systems integration, interoperability	
19. ABSTRACT (continue on reverse if necessary and identify by block number)			
<p>This thesis examines the broad issues and concepts which impact the effectiveness of U.S. Air Force deployable communications. A high level "systems analysis" approach was used in this study to gain visibility on the number of elements involved in deployable communications and their interrelationships. Previous studies were reviewed to determine where trends existed, and contemporary analysis efforts were examined for clarity and cohesiveness. The principles of command and control are discussed, followed by a description of the current family of U.S. Air Force deployable communications equipment and how it supports the warfighters in the deployed environment. Central issues and concepts are developed through trade-off analysis and illustrative examples. Key concepts include: time phased arrival of equipment in theater, modularity of design, strategic/tactical interface, and interoperability. Conclusions indicate that persistent systems integration problems are more the result of organizational and conceptual problems than with the physical technologies. Recommendations include the establishment of a "center of excellence" to coordinate and facilitate systems integration. The tools for such a center include clear policy direction, computer models and simulations, trade-off analysis, and artificial intelligence/expert systems. A conceptual architecture is provided to illustrate the desired relationship between cooperative sub-architectures, and a definition proposed for architectures in an attempt to standardize its interpretation.</p>			
20. DISTRIBUTION/AVAILABILITY OF ABSTRACT <input checked="" type="checkbox"/> UNCLASSIFIED/UNLIMITED <input type="checkbox"/> SAME AS REPORT <input type="checkbox"/> DTIC USERS		21. ABSTRACT SECURITY CLASSIFICATION UNCLASSIFIED	
22a. NAME OF RESPONSIBLE INDIVIDUAL Dan C. Boger		22b. TELEPHONE (Include Area code) (408) 646-2607	22c. OFFICE SYMBOL AS/BO

Approved for public release; distribution is unlimited.

CONCEPTS AND ISSUES FOR SYSTEMS
INTEGRATION OF U.S. AIR FORCE
DEPLOYABLE COMMUNICATIONS

by

Michael A. Cervi
Captain, United States Air Force
B.S.E.E., University of Michigan, 1982

Submitted in partial fulfillment
of the requirements for the degree of

MASTER OF SCIENCE IN SYSTEMS TECHNOLOGY

from the

NAVAL POSTGRADUATE SCHOOL

June 1992

Author:

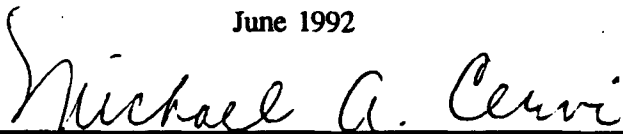

Michael A. Cervi

Approved by:

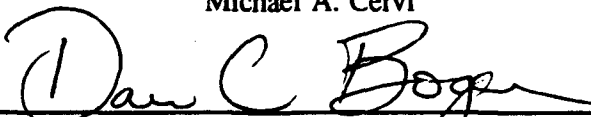

Dan C. Boger, Co-Advisor



Carl R. Jones, Co-Advisor



Carl R. Jones, Chairman

Command, Control, and Communications Academic Group

ABSTRACT

This thesis examines the broad issues and concepts which impact the effectiveness of U.S. Air Force deployable communications. A high-level "systems analysis" approach was used in this study to gain visibility on the number of elements involved in deployable communications and their interrelationships. Previous studies were reviewed to determine where trends existed, and contemporary analysis efforts were examined for clarity and cohesiveness. The principles of command and control are discussed, followed by a description of the current family of U.S. Air Force deployable communications equipment and how it supports the warfighters in the deployed environment. Central issues and concepts are developed through trade-off analysis and illustrative examples. Key concepts include: time phased arrival of equipment in theater, modularity of design, strategic/tactical interface, and interoperability. Conclusions indicate that persistent systems integration problems are more the result of organizational and conceptual problems than with the physical technologies. Recommendations include the establishment of a "center of excellence" to coordinate and facilitate systems integration. The tools for such a center include clear policy direction, computer models and simulations, trade-off analysis, and artificial intelligence/expert systems. A conceptual architecture is provided to illustrate the desired relationship between cooperative sub-architectures, and a definition proposed for architectures in an attempt to standardize its interpretation.

Approved For	
NTIS	X
DTIC	
UNCLASSIFIED	
Justification	
By	
Date	
Dist	
A-1	

TABLE OF CONTENTS

I. INTRODUCTION	1
A. BACKGROUND	1
B. TERMS	2
C. SCOPE	3
D. OVERVIEW BY CHAPTER	3
II. REVIEW OF STUDIES	5
A. BACKGROUND AND OBJECTIVES	5
1. Twenty-First Century Tactical Command and Control (TC ² -21) .	5
2. Tactical Battle Management (TBM)	6
3. U.S. Air Force Tactical Communications	6
B. SIGNIFICANT FINDINGS	7
1. TC ² -21	7
2. Tactical Battle Management (TBM)	7
3. U.S. Air Force Tactical Communications	9
C. RECOMMENDATIONS	10
1. Management Issues	10
2. Technical Issues	11

D.	SUMMARY	11
III.	ARCHITECTURES	13
A.	C ⁴ I FOR THE WARRIOR	13
1.	Concept and Goal	13
2.	The Road Map	14
3.	Moving Toward the Goal	15
a.	Standards	15
b.	Use of Existing Resources	16
c.	Testing	16
B.	JOINT INTEROPERABILITY ENGINEERING ORGANIZATION ARCHITECTURES	16
C.	AIR FORCE COMMUNICATIONS-COMPUTER SYSTEMS ARCHITECTURE	18
1.	Background	18
2.	Architectural Development Fundamentals	19
a.	Attributes	19
b.	Key Concepts	20
(1)	Understanding the User Requirement.	20
(2)	Interoperability.	21
(3)	Open Systems.	21
(4)	Distributed Processing.	21

c.	Common Processes	21
3.	Target Architecture	22
a.	Deployable Communications-Computer Systems	24
b.	Data Management	24
c.	Local Information Transfer	25
d.	Long-Haul Information Transfer	25
e.	Integrated Systems Control	25
f.	Software	25
g.	Security	25
h.	Automated Support Systems	26
D.	AIR FORCE DEPLOYABLE C-CS ARCHITECTURE	27
1.	Current Baseline	27
2.	Target Architecture	27
3.	Evolutionary Path	30
E.	SUMMARY	31
IV.	DEPLOYABLE SYSTEMS AT PRESENT	32
A.	TACTICAL AIR CONTROL SYSTEM	32
1.	The Tactical Air Control Center	33
2.	Tactical Control, Monitoring, and Coordination	34
a.	Control and Reporting Center	35
b.	Control and Reporting Post	35

c.	Forward Air Control Post	36
d.	Message Processing Center	36
e.	Airborne Warning and Control	36
3.	Tactical Air Support and Control	37
a.	Air Support Operations Center	38
b.	Tactical Air Control Parties	38
c.	Forward Air Control	38
d.	Wing Operations Center	39
e.	Airborne Command and Control Center	39
B.	COMBAT COMMUNICATIONS	39
C.	TRI-TAC	41
D.	GROUND MOBILE FORCES SATELLITE COMMUNICATIONS	44
E.	SHORTFALLS AND TRENDS FROM DESERT STORM	45
1.	Phasing of Equipment Arrival	45
2.	Strategic/Tactical Interface	50
3.	Satellite Communication Dependence	50
4.	Paradigm Shift in Operations	50
F.	SUMMARY	51
V.	CENTRAL ISSUES AND CONCEPTS	52
A.	DEFINITION OF C ²	52
1.	JCS Pub 1-02 Definition of C ²	52

2.	C ² is Information Centered	53
3.	Timeliness and Accuracy	53
4.	Boyd's O-O-D-A Loop	55
B.	POLICY AND ASSUMPTIONS	57
1.	Joint Publication 1	58
2.	FACRP	60
3.	The Next Step	63
C.	PLANNING AND DESIGN CONSIDERATIONS	63
1.	Type of Conflict	63
2.	Modularity	64
3.	Statement of Requirements	64
4.	Sizing Requirements	65
5.	Standards	66
6.	Transportation and Phasing of Equipment	67
7.	Dispersal and Distributed Processing	67
D.	SUMMARY	69
VI	CONCLUSIONS AND RECOMMENDATIONS	71
A.	CONCLUSIONS	71
B.	RECOMMENDATIONS	72
1.	Assignment of Responsibility and Authority	72
2.	Follow-up Mechanism	73

3.	Providing the Tools	74
a.	Policy	74
b.	Models	74
c.	Trade-off Analysis	75
d.	Artificial Intelligence	75
4.	Conceptual Clarity	76
5.	Systems Training	78
C.	THE MISSING LINK	79
D.	SUMMARY	80
APPENDIX		81
LIST OF ACRONYMS		84
LIST OF REFERENCES		87
BIBLIOGRAPHY		90
INITIAL DISTRIBUTION LIST		91

LIST OF TABLES

TABLE 1: SUMMARY OF STUDY RECOMMENDATIONS 11

TABLE 2: AF C-CS ARCHITECTURAL GOALS 20

TABLE 3: AF C-CS ARCHITECTURAL OBJECTIVES 20

TABLE 4: TRI-TAC EQUIPMENT 43

TABLE 5: ENVIRONMENT AND STRATEGY CHANGES 61

TABLE 6: C² DRIVERS 62

LIST OF FIGURES

Figure 1: Architectural Options	8
Figure 2: Target Architecture	23
Figure 3: Architectural Building Blocks	24
Figure 4: Automated Support Systems	26
Figure 5: Current Deployable C-CS Architecture	28
Figure 6: Information Transfer Node	29
Figure 7: Interconnected ITN's forming a MOB	29
Figure 8: Theater-wide Connectivity	30
Figure 9: The Tactical Air Control System	33
Figure 10: Deployable Tactical Communications	40
Figure 11: TAB Current (1991)	46
Figure 12: TAB Target (1996-1999)	47
Figure 13: AFCH Current (1991)	48
Figure 14: AFCH Target (1996-1999)	49
Figure 15: Confidence in Information Curve	54
Figure 16: Boyd's O-O-D-A Loop	56
Figure 17: Lawson's C² Model	56
Figure 18: Operational Continuum (1990-Beyond)	59
Figure 19: Example Global Reach Ground Station	70
Figure 20: Architectural Concepts	77

ACKNOWLEDGEMENT

The author wishes to recognize and thank the people whose patience and understanding helped make this thesis a reality. First, to my wife Melanie and son Tony; thank you for the sacrifices you've endured so that I may further my education. You've been great troopers, and I love you all the more for it. Second, to my advisors, Dr. Boger and Dr. Jones, I express my sincere appreciation for your guidance and genuine interest in this effort. Thank you for listening, prodding, focusing, and honing when and where needed. Third, to the many people contacted both within and outside the Air Force, thank you for the time you took to field questions or send documents. This thesis is far better rounded out than it would have been without your help. And finally, it is to the memory of Mr. and Mrs. George Peeples that this thesis is dedicated. I'm saddened that you'll never be able to read these words, but your influence and teachings gave me the strength to keep moving forward. May you rest in peace.

I. INTRODUCTION

A. BACKGROUND

The motivation for this thesis stems from years of frustration on the part of the author to gain an insight into how to "integrate" deployable communications systems. Integrate is set off in quotes because the word can mean many things to many people. In this context, it will be taken to parallel the ideas from systems theory, which states:

- The whole is more than the sum of parts,
- The whole determines the nature of the parts,
- The parts cannot be understood if considered in isolation from the whole, and
- The parts are dynamically interrelated and interdependent. [Ref. 1:p. 10]

This means that communications support is more than just a set of wires between two points. Integration concepts should encompass not only the technical aspects of communications, but also the management and organizational structures which ultimately enable the wires to exist.

Pre-thesis research indicated that the above concept was still not very prevalent among those who are charged with the responsibility to manage deployable systems. This is somewhat understandable given the nature of the task. Communications systems themselves are complex. They are the single common denominator throughout a theater;

every functional area is affected by communications. This makes the gaining of consensus among users challenging due to differing opinions of priorities and requirements. Further, while the management mechanism used to eventually field a system seems to have structure in theory, the execution is frequently considered fragmented in actual operation.

As such, there are two separate threads that run through this thesis: the fundamental issues relating to the physical process of providing communications, and the organizational issues which impact the Air Force's ability to put those physical systems in place. They are distinct, yet intertwined, and systems theory maintains both must be understood if the "whole" of deployable communications is to be understood.

B. TERMS

Many terms have come to be associated with communications over the years. Command and control, or C², is frequently joined with communications to form C³. Later, computers and intelligence were added to C³ to form C⁴I. All terms are used in this paper primarily due to the thrust of the source documents. While the terms are not exactly interchangeable, the frequent use of C³ and C⁴I in documents illustrates the interdependence of elements. This thesis will consider communications as the bridge between where information is processed (computers and intelligence) and where it is used to make decisions (command and control).

C. SCOPE

Tackling a project such as this forced the focus to remain at a fairly high level. Any single issue could lend itself to in-depth analysis. But the challenge is not one of solving individual problems, it is one of integrating all of those solutions into a larger, workable whole. In our case, it is the communications supporting the warfighter in a deployed environment. To stay manageable, the scope was generally limited to Air Force systems, with the understanding that the Air Force systems are themselves part of a larger, joint system.

D. OVERVIEW BY CHAPTER

Chapter II is a review of three previous studies of deployable communications. The objectives, findings, and recommendations of the studies are discussed and summarized.

Chapter III provides a snapshot of the joint and USAF views of architectures. The development flows from high level guidance from the joint staff through to the directives which stipulate the Air Force deployable communications architecture.

Chapter IV describes deployable systems at present. This includes a detailed description of the tactical air control system (TACS), and the communications equipment which supports the TACS and the tactical air base. Shortfalls and trends highlighted from Operation Desert Storm are discussed briefly.

Chapter V explores the central issues and concepts which must be addressed in developing a deployable communications architecture. The emphasis is on understanding the interrelationships between the issues to facilitate and stimulate informed decisions

regarding the potential shape of future systems. Policy, type of conflict to plan for, phasing of equipment arrival, modularity, and distributed processing are key issues.

Chapter VI provides a summary of the research and recommendations to enhance systems integration of deployable communications for the future.

II. REVIEW OF STUDIES

Three studies were reviewed to provide a foundation for the balance of this research. While they differed somewhat in their approach and assumptions, they were remarkably consistent in their findings and recommendations.

A. BACKGROUND AND OBJECTIVES

The studies reviewed were completed between 1985 and 1991, and all were sponsored by the Air Force Systems Command (AFSC).

1. Twenty-First Century Tactical Command and Control (TC²-21)

This study was conducted in 1985 by a group of industry and DoD personnel. Their intention was to "...develop an architectural framework for tactical command and control (C²) for the early twenty-first century period...to guide development of a survivable and sustainable tactical C² capability...", all against a NATO backdrop. Important assumptions were:

- Basic USAF mission and doctrine (as stated in Air Force Manual 1-1) would not change
- Basic tactical C² functions do not change, although the execution and environment could
- The threat and C² structure from the NATO central region provided the baseline of consideration to establish maximum requirements of performance
- The likelihood of worldwide contingency deployments established the need for modularity, flexibility, and transportability [Ref. 2:p. I-1]

2. Tactical Battle Management (TBM)

This study, along with the U.S. Air Force Tactical Communications study, was conducted by the Air Force Studies Board (AFSB). The TBM study was completed in 1986, but the report was not published until 1990 due to changing priorities (as a result of a changing world political climate). Scope was limited to conventional tactical air missions for Europe and Southwest Asia. Their task was as follows:

- Examine the operational requirements, independent of the present or likely capability to satisfy those needs
- Survey and project the technology relevant to decision-aiding information technology
- Match the capabilities to the needs
- Review the current programs and acquisition process
- Recommend ways to facilitate the development of effective TBM aids and related technology [Ref. 3:p. 1]

What this amounts to is to find out where the Air Force can apply decision aids to assist in TBM, and then determine how to put those tools in place.

3. U.S. Air Force Tactical Communications

Completed in 1991, this study was an extension of the earlier TBM study. While the TBM study recognized communications as an important element in TBM, the panel was not chartered or structured to examine it in detail. This study focused specifically on tactical communications support to battle management. By agreement with the sponsor, scope was limited to reviewing the USAF's ability to meet the needs of its contingency forces. Their task was:

- Evaluate planned tactical communications capabilities, with particular emphasis on joint-service and multi-national interoperability
- Examine the technological command and control requirements
- Recommend future concepts for application
- Propose an implementation strategy [Ref. 4:p. 5]

B. SIGNIFICANT FINDINGS

1. TC²-21

This study determined that physical dispersal and functional distribution would be key to survivability for deployed systems. Figure 1 helps to illustrate this point. From a topology standpoint, the greater the separation between elements, the greater the difficulty in locating and targeting them. For functional distribution, their idea was to provide redundancy through spreading the functions throughout the theater versus concentrating them in focused elements. In this way, if one part of the network is disabled, another part can assume its workload. This helps eliminate single points of failure. In addition, to take full advantage of technology, manual methods of battle management must give way to using automated decision-support capabilities. Finally, the need for rapid deployment will drive a "building-block", modular C² approach for transportability and for allowing incremental levels of capability as required. [Ref. 2:p. ii]

2. Tactical Battle Management (TBM)

The TBM study found that current technology would meet the USAF's needs, but must be integrated into the Tactical Air Control System (TACS) to be effective. This is being accomplished through programs such as the Modular Tactical Air Control Center (MTACC), the

Centralized

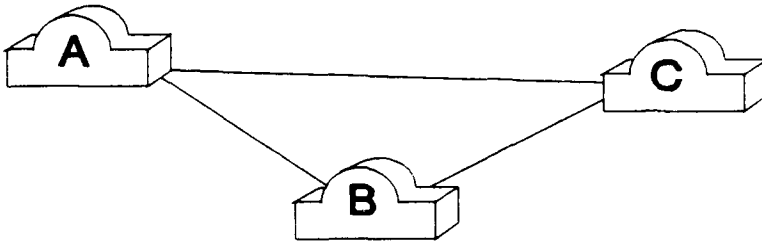

Dedicated support to each function/facility
No replication of functions
Irredundant central processors
Many single-point failures
Readily distinguishable signatures
Limited modularity
Limited interoperability
Low bandwidth, point-to-point communications

Fully Distributed

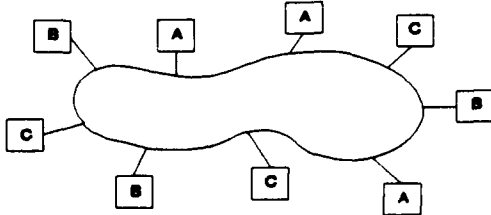

Single common support element
Theater wide function replication
Elimination of single point failures
No distinguishable signatures
Universal modules
High interoperability
High communication loads

Semi-Distributed

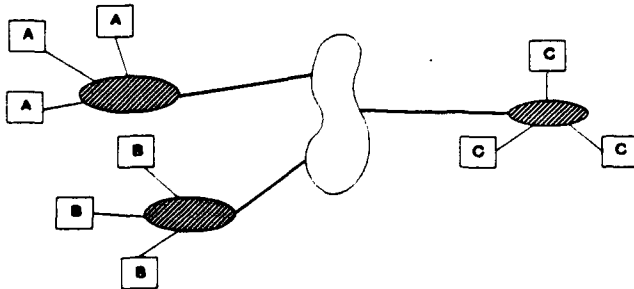

Limited classes of support elements
Dispersed replication of functions
Elimination of single point failures
Minimal distinguishable signatures
Classes of modules
Moderate communication loads

Figure 1: Architectural Options [Ref. 2:p. III-19]

Contingency TACS Automated Planning System (CTAPS), and the Modular Control Element (MCE). However, they stated the current development and acquisition system does not get this new technology into the field fast enough to meet the Air Force's needs for TBM. It takes too long, and items are frequently outdated by the time they are fielded. It was pointed out that an acquisition system which works well for weapon systems does not provide the flexibility needed when technologies are rapidly evolving. Finally, the lack of coordinated effort to field essential systems has severely impacted the Air Force's ability to manage tactical air warfare. [Ref. 3:pp. 3-4]

3. U.S. Air Force Tactical Communications

This study highlighted discrepancies in the areas of testing, architecture and engineering. They found that communications systems were not stressed during testing in a way that would be typical of a warlike environment. This may be at least partially related to the next point of there being a lack of knowledge regarding the network loading demands which might be experienced under warlike conditions. Without this information, it is difficult to realistically stress a network during testing or exercises. Finally, they noted there is a lack of adequate systems architecture and systems engineering. According to the report:

Planning, development, and management of the tactical communications system has been and is fragmented and dispersed among several organizations. The Air Force must establish a structure for TBM, including the supporting communications, so that the developing technologies and the evolving command, control, communications, and intelligence capabilities 'fit' into and contribute to the overall system. [Ref. 4:p. 8]

C. RECOMMENDATIONS

The study recommendations fell into two broad categories: those that related to the management of the systems (development, acquisition, and implementation) and those that were concerned with the technical means of providing deployed command and control.

1. Management Issues

The number one issue from all studies was that a tactical C² or battle management architect must be designated and given clear responsibility and authority to accomplish the task of systems integration. It was noted that the process of design and implementation of systems was fragmented among many different offices, and no single agency was responsible for oversight and integration of the various efforts [Ref. 2:p. IV-1, Ref. 3:p. 4, Ref. 4:p. 13]. The TBM study along with the TC²-21 were critical of the development, acquisition, and testing arenas. TBM suggests a better interaction between the users and developers since requirements tend to be dynamic and difficult to state in detail. Rapid prototyping and field testing (what they call "build a little, test a little") will ultimately be the key to successful development [Ref. 3:p. 4]. TC²-21 pointed out the need for a comprehensive test bed. At the time of its writing, equipment and expertise were spread across the country. Little if any networking existed to tie these sites together [Ref. 2:p. IV-3]. While the National Test Bed (NTB) concept seeks to tie research, development and operations sites together through a distributed network, it is unclear if TC²-21 was a motivating factor. The USAFTC study further suggested rapid prototyping and field testing as part of the evolutionary acquisition approach [Ref. 4:p. 14]. Table 1 summarizes these and the following recommendations.

2. Technical Issues

While not a specific recommendation except from the TC²-21 study, all reports noted that simply using many of the equipments and concepts already available in the private sector will provide the ability to field smaller, lighter, and more modular equipment. The USAFTC study points out that much of our current equipment is based on 1960's technology [Ref. 4:p. 9]. Advances in electronics and packaging (large scale integration of components) since that time have yielded large reductions in size and weight. Finally, the USAFTC states the tactical C³ system must remain robust under operational stress and continue to fulfill its essential missions. To do this requires knowledge of the missions, expected degradations under stress and enemy countermeasures, and loading of the supporting communications network. [Ref. 4:p. 14]

TABLE 1: SUMMARY OF STUDY RECOMMENDATIONS

RECOMMENDATIONS	TC ² -21	TBM	TC
1. Integrate planning & C ² architectures	XX	XX	XX
2. Greater flexibility and user interface in development, acquisition, and testing	XX	XX	XX
3. Comprehensive testing	XX		XX
4. Develop smaller, lighter, more modular equipment	XX		
5. Robust network under stress			XX

D. SUMMARY

The studies reviewed all made the point of needing to designate a systems architect and engineer, and to vest in them the authority to integrate the many aspects of systems design as it

is currently performed. Rapid prototyping and field testing, and greater use of commercially available items will also speed the transfer of higher technology equipment into the Air Force's deployable communications systems.

III. ARCHITECTURES

This chapter is an overview of the joint and Air Force concepts and architectures which are currently guiding the planning and implementation of deployable systems.

A. C⁴I FOR THE WARRIOR

C⁴I for the Warrior (referred to in this section as simply C⁴I) is a concept paper developed by the Joint Staff/J-6 office [Ref. 5]. It provides a high level view of what is expected for the warrior and how to transition current systems toward that goal.

1. Concept and Goal

The idea behind C⁴I is to take a top-down approach to integrating technology into deployable systems, versus the usual bottom-up approach which can introduce new technology quickly but tends to fragment its implementation. The result of the bottom-up approach has been the fielding of a great deal of helpful equipment, but much of it operates in a stand-alone mode, overloading the warfighter with too much information that is uncorrelated between sources. This is unacceptable in a era of increasing emphasis on joint operations. The ultimate goal of C⁴I is to provide "...a fused, real time, ground truth picture of [the warrior's] battle space and the ability to order, respond and coordinate horizontally and vertically to the degree necessary to prosecute his mission in that battle space." While many elements must work together to make this happen, the focus in this document was only on equipment, not on procedures or doctrine. [Ref. 5:p. 2]

2. The Road Map

While many architectures provide a view of systems on the horizon that will be all things to all users, C⁴I argues that none will provide the needed interoperability today. What is needed is an affordable way to make the current systems interoperate to give our warfighters the needed edge. With an ideal of being able to pull from the ether whatever the warfighter needs, C⁴I states that standardizing our information exchange will enable us to gain the needed interoperability and provide the required "picture" for the warrior.

The single, overriding fact is that interoperable systems must exchange information. The foundation needed for interoperability is formed by defining the criteria to exchange information. **THE STANDARD** that is needed is a very straight forward definition of the communications protocol and data format required to input and extract information from the 'data base in the ether.' [Ref. 5:pp. 5-6]

There are a number of advantages to making existing systems interoperable through information exchange. The primary reason is that the cost becomes reasonable-- instead of entirely new systems, only interfaces need to be built to allow existing systems to talk. In addition, existing systems are already performing the missions assigned and commanders are comfortable with them. What is needed is to enhance their "picture" through greater access to a more extensive data base. The point is made that for survivability reasons, the "data base in the ether" should not be a single data base, but rather a distributed data base. Service architectures would fit under this concept simply by meeting the communications protocols and data formats established within the data base. [Ref. 5:p. 6]

C⁴I accepts that getting "from here to there" will still be a long, costly process, but insists that the goals must be set today and adhered to, or else they will never be achieved. The focus will be on concepts such as open systems architecture, pull of information (from the data base) versus pushing everything into a commander and letting him sort it out, data standards, fusion of intelligence, and tools such as expert systems and artificial intelligence to enable construction of the ultimate architecture. [Ref. 5:p. 6]

3. Moving Toward the Goal

C⁴I outlined three areas that will provide the means to realize the goal of interoperability between existing systems and the long range architecture: standards, use of resources, and testing.

a. Standards

An instrumental factor in defining standards has been the establishment of the Defense Information Systems Agency (DISA) (and the Joint Interoperability Engineering Organization (JIEO) within DISA) as the single focal point within DoD for standards. Getting this concept institutionalized will require all of the CINC's and services to use the DISA standards. In addition, the standards must be kept as simple as possible. The example of 60 cycle, 115 volt household electricity is used as an analogy. The rationale is that keeping the standards simple will keep program costs down. [Ref. 5:p. 7]

b. Use of Existing Resources

A suggested starting point for an interoperability program would be to examine the existing data formats currently in use, as well as those that industry can offer. Studying the current information set may allow correlation of some elements into an ultimately smaller and more clearly defined set of data elements. The desire is to keep that set as small as possible. Some standards may be able to be used as is, while others might need slight or even complete modification. Once the standard is defined, the issue of compliance comes up. Compliance will be the responsibility of the system owners, and will be verified through testing. [Ref. 5:pp. 7-8]

c. Testing

Just as a focal point has been appointed for standards, the Joint Interoperability Test Center (JITC) at Fort Huachuca, AZ will be the focal point for interoperability testing. The recommendation is to make testing an early priority in program life. Eventually, the JITC will have a distributed test capability which will no longer require the equipment to be physically located at their premises. Testing will be possible through "dial-in" connectivity aimed at making compliance easier and earlier in program development. [Ref. 5:p. 8]

B. JOINT INTEROPERABILITY ENGINEERING ORGANIZATION ARCHITECTURES

The Joint Interoperability Engineering Organization (JIEO) serves as the DoD systems engineer for C⁴ information systems. In this capacity, they look primarily at

interoperability issues between forces supporting the deployed CINCs. They look at architectures from three standpoints: long-range objective, CINC interoperability, and functional interoperability. [Ref. 6]

The long-range objective architecture program reviews the current and long-range service architectures for potential duplication or interoperability problems. JIEO hosted an objective architecture conference in September 1991 where the services briefed their conceptual architectures and discussed potential interoperability problems. [Ref. 6]

The CINC interoperability program reviews the C⁴ requirements of the CINC, and identifies the elements that will provide C⁴ support. These elements could be U.S. forces, Federal agencies, or allied/coalition forces. Assessments of C⁴ capabilities are made, deficiencies identified, solutions recommended, and a detailed implementation plan developed. [Ref. 6]

The functional interoperability program focuses on specific mission areas and is not limited in scope to a specific CINC. Again, an assessment of current capabilities is made, deficiencies identified, solutions recommended, and an implementation plan developed. [Ref. 6]

Because the products developed are generally classified, no diagrams are included in this paper. In addition, many of the documents are under revision in an attempt to standardize the information provided. Eventually, these documents will serve as the design model for C⁴ systems in the joint environment. [Ref. 6]

C. AIR FORCE COMMUNICATIONS-COMPUTER SYSTEMS ARCHITECTURE

Guidance for the Air Force Communications-Computer Systems (C-CS) Architecture is contained in Air Force Pamphlet 700-50, Volume I. It ensures that:

...validated communications-computer systems requirements are satisfied with integrated, affordable solutions. [An architecture's] purpose is to provide standards, systems, protocols, interfaces, and so forth, that must be considered when developing, implementing, or modifying Air Force communications-computer systems. [Ref. 7:p. 3]

The intent of the architecture is to keep "today's innovative solution" from becoming tomorrow's integration nightmare.

1. Background

The need for an architecture is driven by the number of systems introduced by the various communities (whether functional area, base- or command-level, or Air Force wide, or those supporting weapons systems) to meet unique needs. Without a plan, all compete for the same limited resources of dollars, cable plant, and space, and with little regard toward interoperability with other systems. [Ref. 7:p. 3]

This situation occurred as an outgrowth of the rapid expansion of technology over the last 20 years. As users have become more literate in the new technologies, they, in turn, developed new applications to automate and enhance their operations. Finally, as products became available, requirements tended to be written in terms of hardware desired, not a capability. Frequently, the technical community was not consulted for ways to satisfy the requirement. [Ref. 7:p. 3]

The 700-series regulations outline a process and family of documents to provide the guidance needed to pull all of the elements together. They move from the more abstract "vision" outlined in the Planning and Architectural Guidance (a ten year planning horizon) to the defined roadmaps that will provide the goal architecture, and finally the programming and implementation phases which work in shorter horizons and more concrete terms. [Ref. 7:pp. 4-5]

2. Architectural Development Fundamentals

There are certain goals, attributes, key concepts, and common processes which must span all C-CS efforts. Goals provide the common direction for all levels as systems are reviewed for improvement. The goals of the Air Force C-CS architecture, and the more specific objectives which support them are shown in Tables 2 and 3. [Ref. 7:p. 8]

a. Attributes

An architecture must have influence if it is to affect the long-term C³I infrastructure. It must also provide a structure to guide the entire life cycle of a program and its equipment. The focus must be on wartime requirements, and it must specify systems which will meet military requirements even in an era of fiscal contraction. [Ref. 7:p. 8]

TABLE 2: AF C-CS ARCHITECTURAL GOALS [Ref. 7:p. 8]

GOALS
<i>1. Ensure mission essential needs for communications-computer systems are supported.</i>
<i>2. Exploit information as a resource to enhance mission effectiveness and efficiency in both wartime and peacetime.</i>
<i>3. Ensure mission-essential communication-computer systems are as functionally survivable and enduring in stressed environments as the forces supported.</i>
<i>4. Ensure communications-computer systems which process sensitive information provide an adequate level of information protection.</i>
<i>5. Exploit technology to improve the effectiveness and efficiency of communications-computer systems to meet Air Force wartime and peacetime mission requirements.</i>

TABLE 3: AF C-CS ARCHITECTURAL OBJECTIVES [Ref. 7:p. 8]

OBJECTIVES
<i>1. Focus the efforts of communications-computer systems organizations to provide better end-user support.</i>
<i>2. Enhance communications-computer systems support to end-users to increase mission effectiveness or permit reduction in resource requirements.</i>
<i>3. Provide end users with powerful, flexible, integrated tools to improve responsiveness.</i>
<i>4. Enhance user friendliness of communications-computer systems to reduce training requirements associated with their use.</i>
<i>5. Provide modern, machine-independent software engineering tools to expedite development of major systems.</i>
<i>6. Increase portability through "open systems."</i>

b. Key Concepts

(1) *Understanding the User Requirement.* Understanding the user requirements (what they call "user information needs") entails information flows, possible stress points, and the impact of environmental dynamics. Requirements should be stated in terms of mission needs, and not in terms of specific hardware or technologies. [Ref. 7:p. 8]

(2) *Interoperability*. Since data frequently moves from one system to another, systems must be interoperable and compatible with each other at the boundary. As more systems are interconnected, the technical architecture should guide system design to ensure interoperability at the time of implementation. [Ref. 7:p. 9]

(3) *Open Systems*. Open systems allow equipment from many different manufacturers to co-exist and interoperate. With renewed emphasis on fully competitive contract awards, the C-CS environment will have even greater vendor diversity in the future. The layered approach in open systems, which specifies where certain technical functions are performed, provides the ground rules any new system must meet. [Ref. 7:p. 9]

(4) *Distributed Processing*. The idea here is to move the information as little as possible and keep it as close as possible to the user to meet their needs. The pamphlet suggests a robust, shared network of interconnections to facilitate distributed processing and standards to define information exchange to minimize data conversions. [Ref. 7:p. 9]

c. Common Processes

All architectures, regardless of nature or scope, are to follow the same basic development process. The steps are as follows:

1. Describe the baseline architecture,
2. Identify system requirements,
3. Identify key factors that affect the architecture,

4. Develop a target architecture,
5. Define an evolutionary path, and
6. Develop acquisition and implementation strategies to reach the target. [Ref. 7:p.9]

3. Target Architecture

The target architecture is shown in Figure 2, and is expected to employ concepts stated earlier in a "system of systems which will be robustly interconnected to responsively serve all users." The target does not carry a specific time for implementation, but most of the features are expected to be in place by the year 2010. [Ref. 7:p. 11] The target will use the concepts of open systems, multi-level security, and centralized communications with distributed processing. Data and software are to be standardized to enable the sharing of resources (such as data elements) and reduce duplication of effort. [Ref 7:p. 14] The interplay between the "building blocks" used in the development of the architecture is illustrated in Figure 3.

Each building block is also a "technical architecture" documented in additional volumes of AFP 700-50. Because many of the technical architectures/building blocks appear in the architecture of interest (deployable systems) it is helpful to briefly explain the role of each.

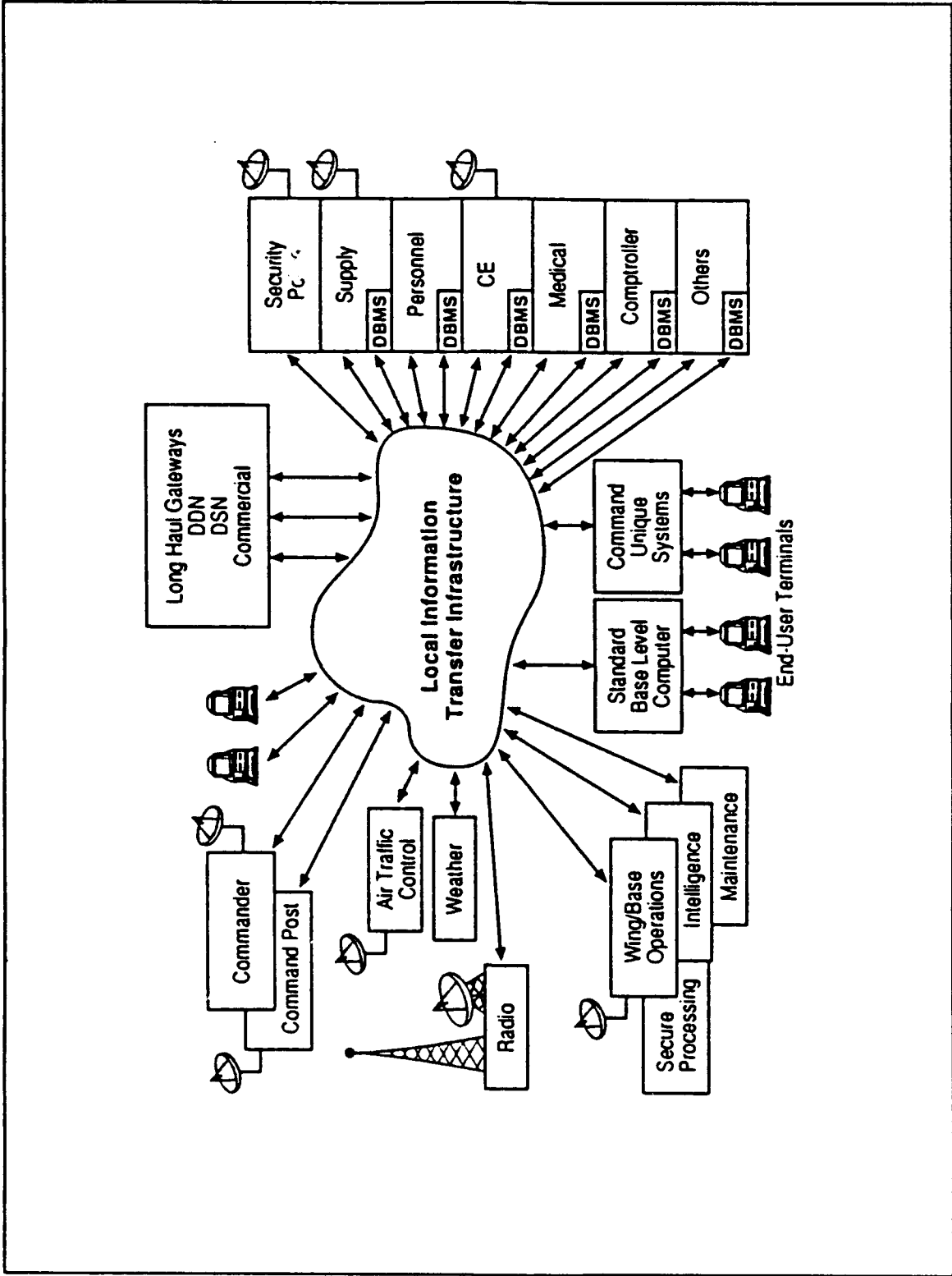

Figure 2: Target Architecture [Ref. 7:p. 11]

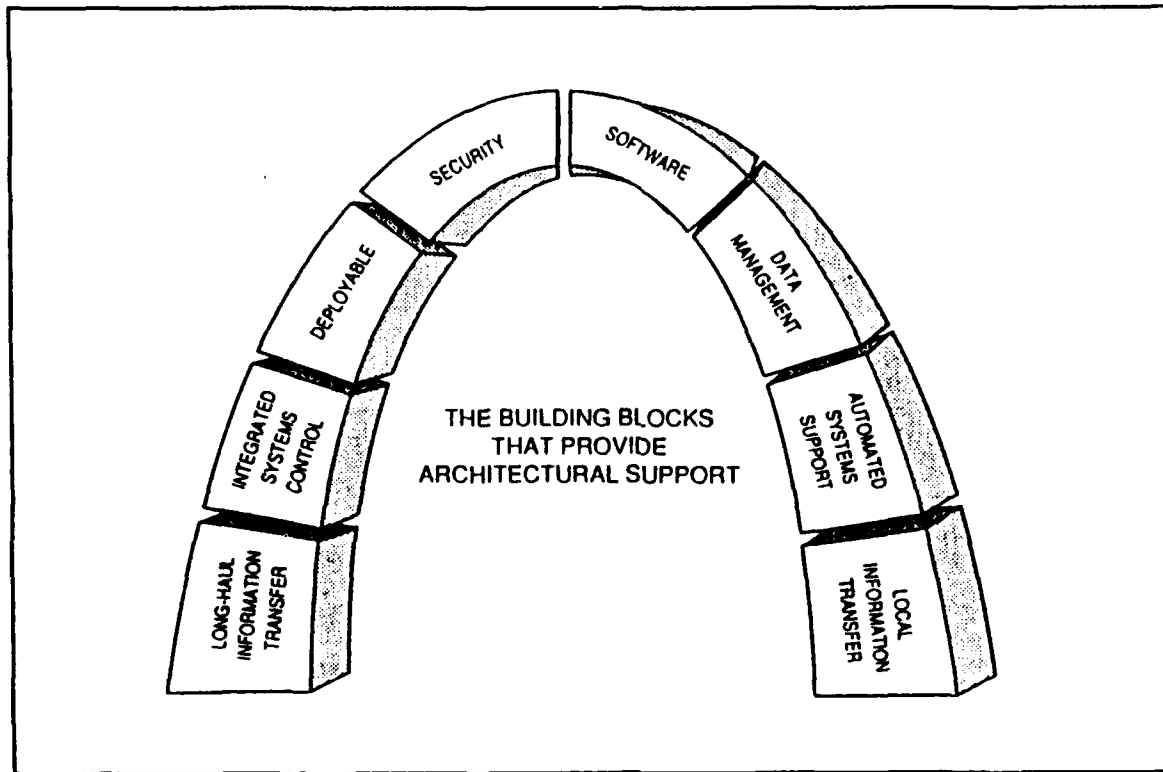

Figure 3: Architectural Building Blocks [Ref. 7:p. 12]

a. *Deployable Communications-Computer Systems*

Deployable systems support a wide range of users through switching equipment, transmission media, and access to common-user systems in a deployed environment. They provide both intra- and inter-theater connectivity through either local or long-haul information transfer. [Ref. 7:p. 11]

b. *Data Management*

Data management sets up the standards which allow different applications programs running on different hardware the ability to share data as a corporate resource. [Ref. 7:p. 11]

c. *Local Information Transfer*

Local information transfer is the movement of voice, data, video, and other services within a base environment. [Ref. 7:p. 11]

d. *Long-Haul Information Transfer*

Long-haul systems provide connectivity to the common-user systems managed by DISA, and dedicated command and control systems which reside outside the intrabase environment. [Ref. 7:p. 13]

e. *Integrated Systems Control*

Integrated systems control provides the equipment and procedures to monitor and troubleshoot network facilities as needed. It serves as a technical control point for fault isolation and detection at base level. [Ref. 7:p. 13]

f. *Software*

Future software acquisition and development will be based upon commercial products already available, Ada (the DoD standard language), and standard databases, tools, and supporting languages. Configuration control will continue to be a priority. [Ref. 7:p. 13]

g. *Security*

The objective of security is to protect information from either physical or electronic compromise. Technical and procedural measures are employed to accomplish this task. [Ref. 7:p. 13]

h. Automated Support Systems

This area includes the dedicated and shared-use computer systems in the base environment, with a focus on standard systems. Computers can be those acquired from standard requirements contracts or from other sources. An example of the current automated support systems is shown in Figure 4. [Ref. 7:p. 13]

The above concepts all support the overall Air Force C-CS architecture. Deployable systems naturally use many of the same building blocks to develop the sub-architectures used to support deployed forces. The deployable C-CS architecture is discussed next.

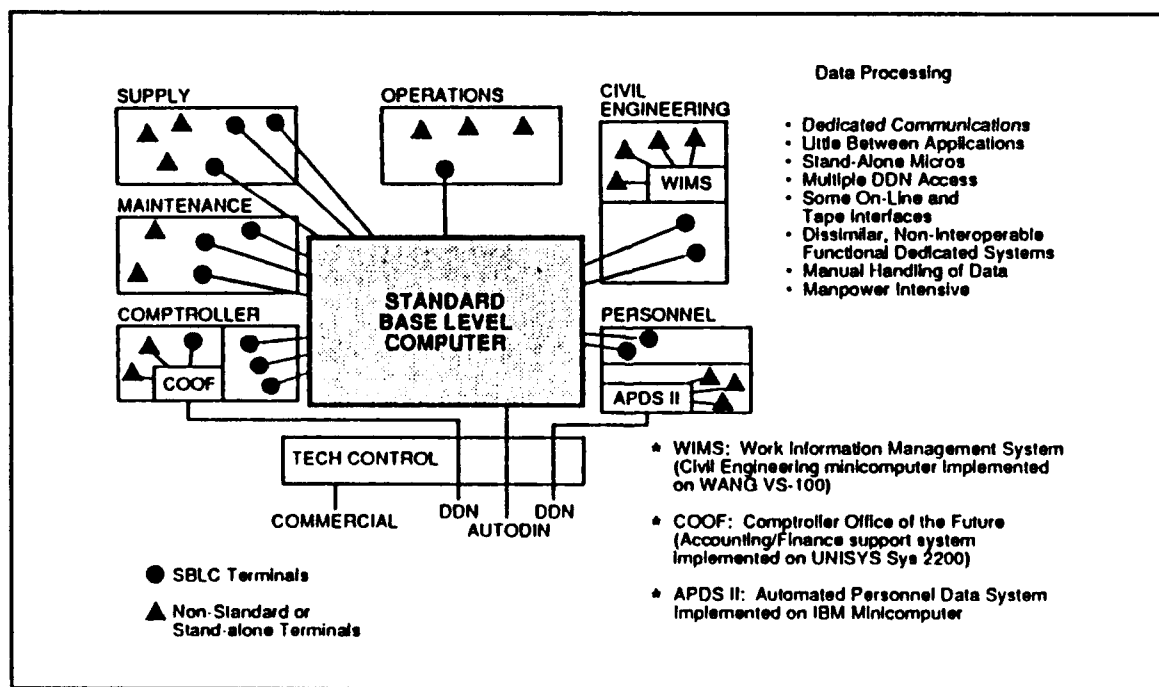

Figure 4: Automated Support Systems [Ref. 7:p.13]

D. AIR FORCE DEPLOYABLE C-CS ARCHITECTURE

The Air Force Deployable C-CS Architecture (DCSA), as stated in AFP 700-50, Volume II, provides the technical structure to realize the target architecture and defines an evolutionary path to follow. The document parallels the steps outlined in Section III.C.2.c in providing background, the current baseline, the target, and an evolutionary strategy. The background is similar to that presented earlier, so will not be repeated.

1. Current Baseline

The current baseline of equipment is as depicted in Figure 5. The equipment provides the supporting infrastructure for control of combat air forces, airlift assets, and the main operating bases (MOB's). [Ref. 8:p. 10] The present deployable systems are covered in greater detail in Chapter IV.

2. Target Architecture

The target architecture is designed to overcome shortfalls in the areas of voice, data, and transmission systems through an integrated, digital, common-user, distributed network. Commercially available technologies and standards, coupled with open systems will be used to the maximum extent possible. Components should be the same as their fixed-station counterparts, or re-packaged (but not re-designed) to meet unique military requirements. [Ref. 8:p. 28] The target architecture is centered around an Information Transfer Node (ITN). The ITN serves to route information packets and performs network functions. Concepts presented during Chapter II are also included, i.e., modularity and distributed systems. Figure 6 shows how an ITN acts as "the primary

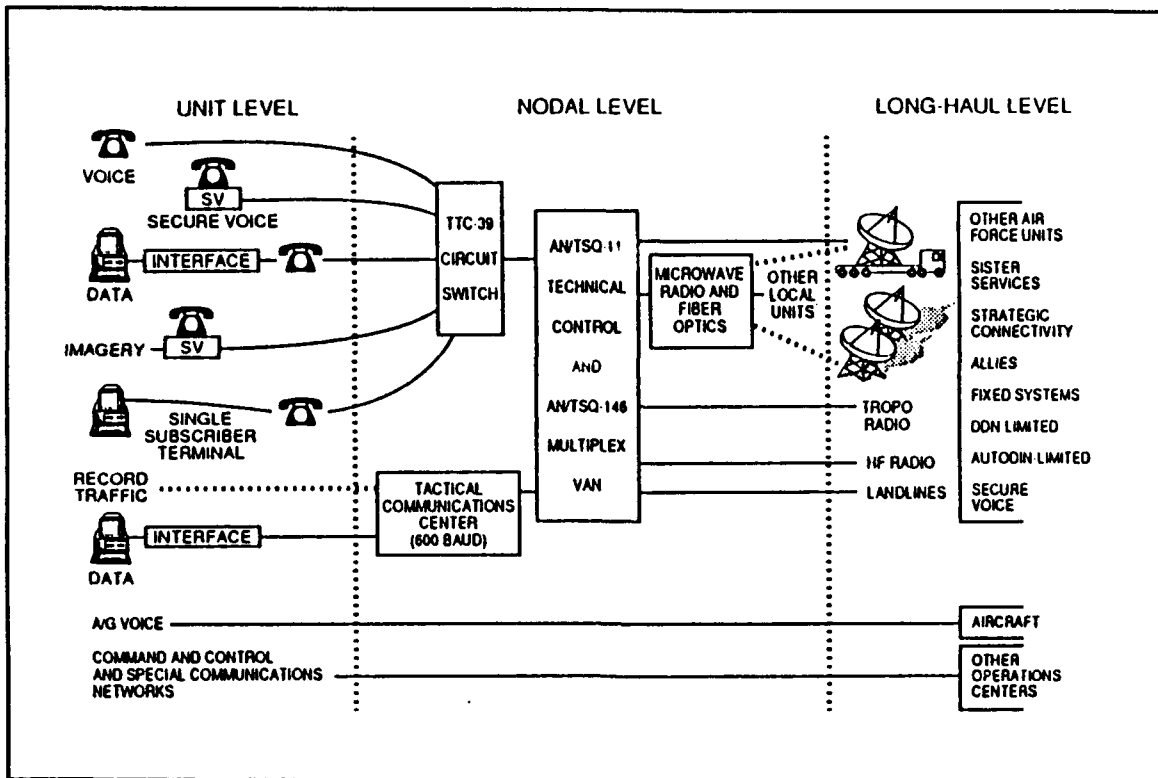

Figure 5: Current Deployable C-CS Architecture [Ref. 7:p. 12]

building block" for intrabase communications. Each topology will be tailored to the specific needs of the attached users. [Ref. 8:p. 37] Groups of users are further interconnected across the deployed base through a communications backbone as shown in Figure 7. This allows users to transfer information throughout the MOB, and to reach long-haul lines not homed off of their ITN. [Ref. 8:p. 38] Finally, Figure 8 depicts many MOB's interconnected. This provides connectivity throughout the theater, and into the fixed systems via Defense Communications System (DCS) gateways. [Ref. 8:p. 42]

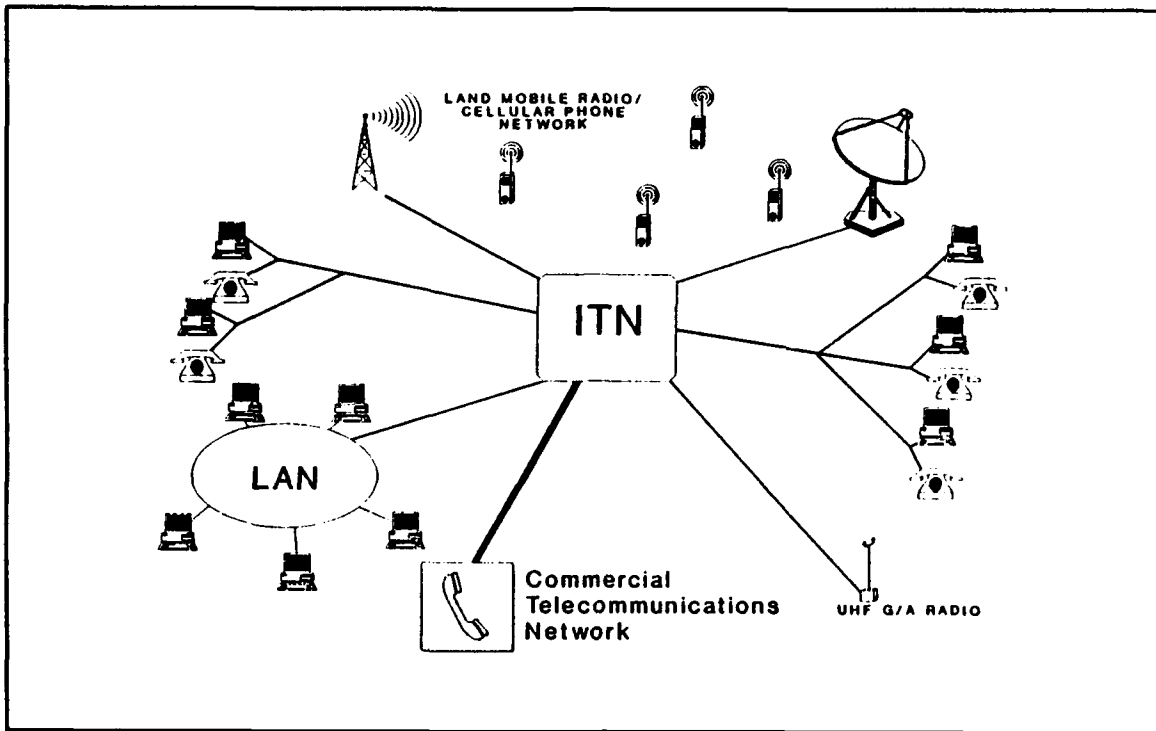

Figure 6: Information Transfer Node [Ref. 8:p. 38]

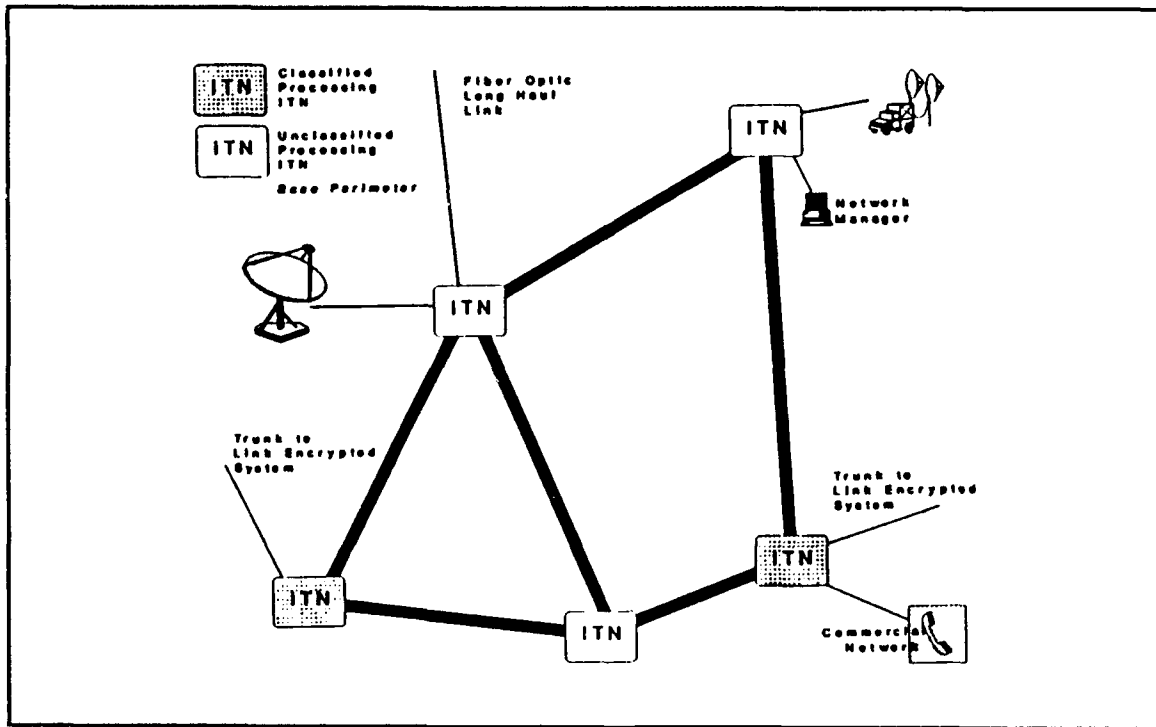

Figure 7: Interconnected ITN's forming a MOB [Ref. 8:p. 39]

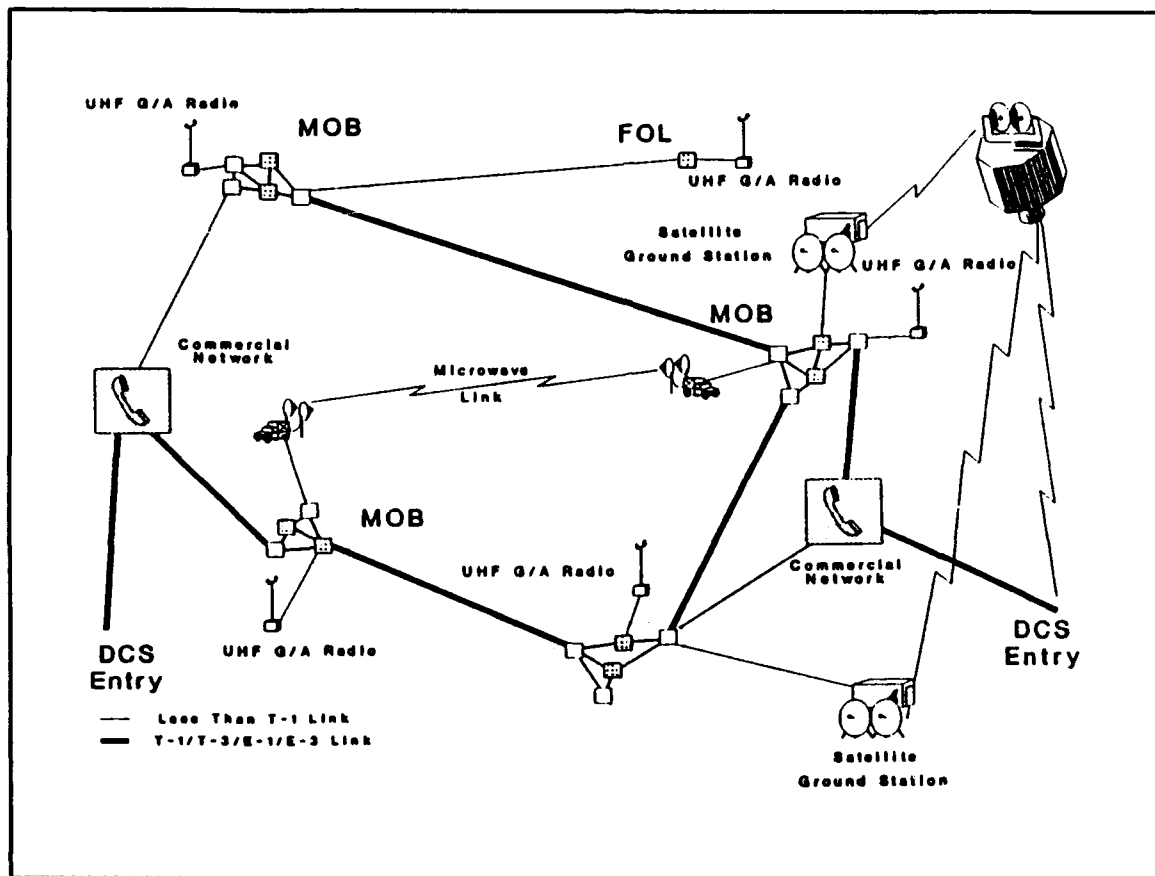

Figure 8: Theater-wide Connectivity [Ref. 8:p. 43]

3. Evolutionary Path

The evolutionary path in AFP 700-50 Vol. II is a restatement of previous ideas: using an evolutionary approach to integrating commercially available standards, technologies, and concepts into the DCSA. The rationale is simple: fiscal constraints will not allow the fielding of an entirely new family of equipment. Interfacing existing systems to new systems (or among non-interoperable current systems) will be both a priority and challenge. [Ref. 8:p. 46]

E. SUMMARY

The consensus from the high level joint guidance through the Air Force technical architecture is that deployable systems must be able to support the warfighter. Since solutions are needed now, and money is hard to come by, interfaces will play a major role in this evolution. The long range objective is to incorporate as much off-the-shelf equipment and technology into the deployed environment as possible. This should ensure interoperability among users within the theater, and between the fixed environment and deployed systems.

IV. DEPLOYABLE SYSTEMS AT PRESENT

This chapter provides an overview of the deployable equipment presently in use, and introduces some of the challenges presented to those systems during Operation Desert Storm. The Tactical Air Control System (TACS) and combat communications provide the bulk of what is generally considered deployable or tactical communications. Although their missions are different, much of their supporting communications infrastructure is the same.

A. TACTICAL AIR CONTROL SYSTEM

The TACS is, as its name states, a system. A number of components serve to pull the entire air picture together. In broad terms, the TACS has two primary missions: control and monitor the movements of tactical aircraft, and provide the means for request and control of tactical air support (also known as close air or ground support). Figure 9 shows the overall TACS [Ref. 9:p. 32]. The TACS uses the principle of centralized control and decentralized execution in both structure and operation. Its focal point is the Tactical Air Control Center (TACC).

History has shown the absolute necessity for centralized control and decentralized execution in tactical air operations. A TACC is the hub of that activity. A TACC is the operational facility in which the Air Component Commander (ACC) plans, directs, and controls tactical resources. The TACC enables the ACC and his senior staff to supervise the activities of assigned or attached forces and to monitor the actions of both enemy and friendly forces. [Ref. 10:p. 1]

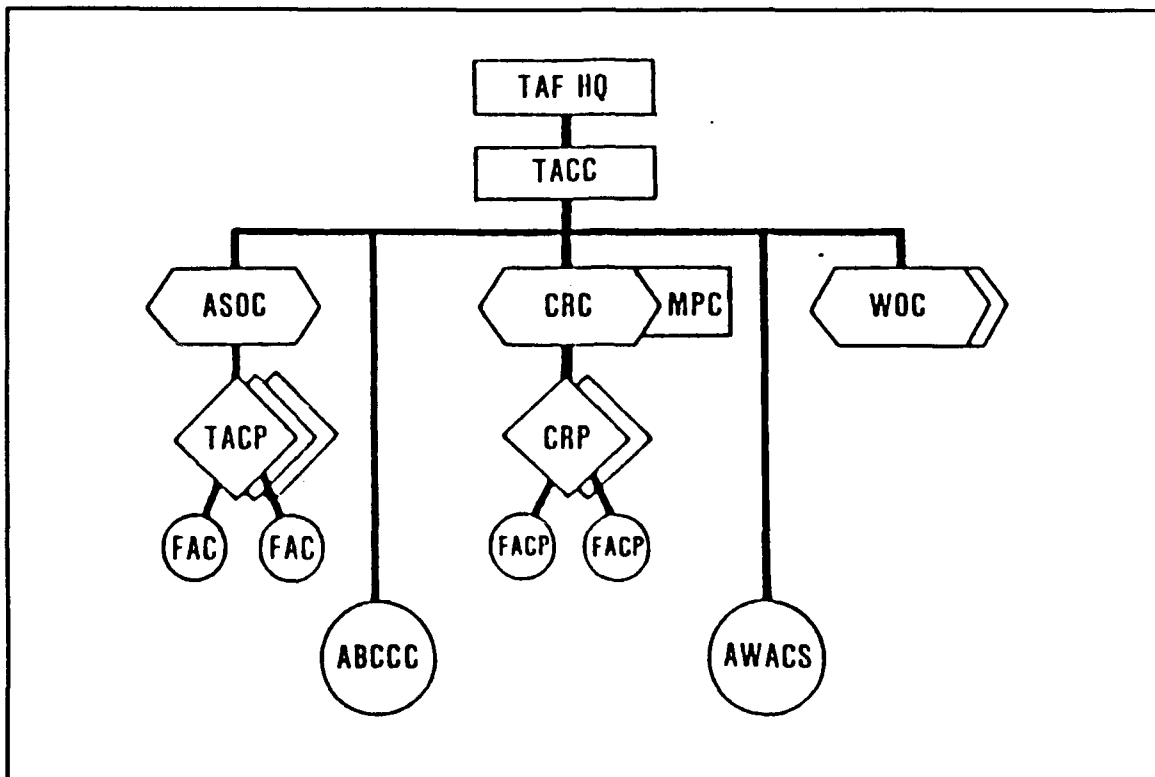

Figure 9: The Tactical Air Control System [Ref. 9:p. 32]

1. The Tactical Air Control Center

The functions of the TACC are: force employment, flight management, battle management, and systems management. Force employment is the result of the Air Tasking Order (ATO)--the translation of the ACC's guidance and strategy into coordinated and detailed execution orders. Flight management monitors the progress of assigned missions. Battle management is control of actions taken in direct response to those of enemy forces, while systems management ensures the smooth flow of C² information between the various elements of the TACS. [Ref. 10:p. 1]

In the joint arena, the TACC is the C² system that supports the Air Force Component Commander/Commander Air Force Forces (AFCC/COMAFFOR) for airspace management. It is dedicated to and operationally responsive to him for airspace control, air support coordination and control, and air strike coordination and control. Decentralized execution of air missions (the ATO) by subordinate elements of the TACS promotes mission effectiveness and enhances responsiveness. [Ref. 11:p. 4-24]

The combat plans division of the TACC develops the ATO based upon mission objectives, availability of forces, and the tactical situation. It tasks units to accomplish specific missions in support of the commander's objectives, and contains enough detail to enable the air crews and TACS elements to accomplish those missions. [Ref. 10:p. 2] The combat operations division then provides centralized control, monitoring, and supervision of the decentralized execution of the ATO. Flexibility is built in to allow adjustment to the ATO should the tactical situation dictate. [Ref. 10:p. 4]

2. Tactical Control, Monitoring, and Coordination

The TACS uses a tiered approach to assist the TACC in its tasks of controlling, monitoring, and coordinating tactical aircraft (and then reporting their movements). The subordinate elements to the TACC are the control and reporting centers (CRC's), the control and reporting posts (CRP's), the forward air control posts (FACP's), the message processing center (MPC), and the airborne warning and control elements. [Ref. 9:p. 32]

a. Control and Reporting Center

The CRC is directly subordinate to the TACC and is the primary element concerned with decentralized execution of air defense and air space control operations. The CRC gets its tasking and receives weapons allocations from the TACC. Sensor or radar information comes to it from ground-based sources (such as the CRP's and FACP's) as well as airborne elements. [Ref. 11:p. 4-24]

Within its area of responsibility, the CRC directs the region or sector air defense and provides aircraft control and monitoring for both offensive and defensive missions. It relays, as directed, mission changes to aircraft and coordinates control of missions with subordinate TACS elements and other agencies. In addition, it has the following responsibilities:

- Supervise subordinate radar elements
- Provide threat warning for friendly aircraft
- Ensure air defense assets of all services are employed in mutually supporting roles
- Coordinate procedures based upon friendly artillery fire plans
- Establish the means for air traffic regulation and identification
- Support air rescue operations [Ref. 12:p. 4]

b. Control and Reporting Post

The CRP is subordinate to the CRC and provides radar surveillance and aircraft control within an assigned sector. It has similar capabilities to the CRC and can

assume CRC functions when directed. One or more CRP's may be employed depending upon area size, terrain, and anticipated level of threat. [Ref. 11:p. 4-24]

c. Forward Air Control Post

The FACP is the mobile radar element subordinate to the CRC or CRP. It is normally deployed into forward areas to extend radar coverage and to provide control of air operations, early warning surveillance, and gap filler service. Because of its mobility and compact design, the FACP can be quickly moved to maintain a desirable location for a changing tactical situation. During initial or contingency operations, a FACP may be the only ground radar available, and would report directly to the TACC. [Ref. 12:p. 5]

d. Message Processing Center

The MPC supports the TACC, CRC's, and CRP's, acting as the interface control unit for the TACS. It is the primary element of the TACS that provides for the automatic exchange of data with other services and air defense systems. It uses the tactical data link (TADIL) to "talk" to other services, and provides the capability to translate from one TADIL format to another. This last feature enhances overall service interoperability since at least two formats are currently in use between the three military departments. [Ref. 11:p. 4-26]

e. Airborne Warning and Control

The airborne warning and control system (AWACS) provides an airborne radar platform coupled with a C² capability. This enables it to perform the function of

a CRC or CRP, or to provide enroute C² during a tactical deployment. The basic mission responsibilities include surveillance, warning, control, and battle management. The AWACS can detect initial hostile air action and provide its radar picture to ground and naval units via the TADIL. In addition, the AWACS can monitor surface vessels and provide the capability to monitor enemy naval activity, and deny them the advantage of conducting covert operations in an area where no surface radar exists. The AWACS can also provide information on friendly ground forces through the use of transponders. [Ref. 12:p. 9]

The Joint Surveillance Target Attack Radar System (Joint STARS) aircraft is not shown as part of the TACS in Figure 9 because it is still under development, but it provides a look-down radar to capture the area beyond the forward line of troops (FLOT). It has a moving target indicator (MTI) which will detect vehicles in either a broad or focused mode, and a synthetic aperture radar which can provide terrain mapping or coverage for fixed targets. [Ref. 13:p. 53]

3. Tactical Air Support and Control

The elements that assist the TACC in its task of tactical air support and control functions are the air support operations center (ASOC), tactical air control parties (TACP's), forward air controllers (FAC's), the wing operations center (WOC), and the airborne battlefield command and control center (ABCCC). [Ref. 9:p. 32]

a. *Air Support Operations Center*

The ASOC is collocated with the senior Army tactical operations center. The ASOC plans, coordinates, and directs immediate tactical air support of ground forces. It is subordinate to the TACC, and provides fast reaction for immediate requests for close air support, tactical air reconnaissance, and in some situations, tactical airlift. [Ref. 12:p. 6]

b. *Tactical Air Control Parties*

TACP's are subordinate to the ASOC and are located at each appropriate command echelon of the supported ground force, normally battalion through corps. They assist the commander through the request and coordination of preplanned and immediate tactical air support. [Ref. 12:p. 7]

c. *Forward Air Control*

The FAC's and Airborne-FAC's (A-FAC's) are subordinate to the TACP's and primarily dedicated to direct support of friendly ground forces. They provide the detailed coordination and control of close air support that integrates air-delivered firepower with friendly ground force fire. Although the FAC's primary missions are controlling attacks, requesting air support, and providing immediate battle damage assessment, the A-FAC also performs air surveillance and search and rescue operations as needed. [Ref. 12:p. 7]

d. *Wing Operations Center*

The WOC is subordinate to the TACC and serves as the airwing commander's headquarters. He uses the WOC, with its facilities and staff, to manage and control sortie generation by his wing. [Ref. 9:p. 35]

e. *Airborne Command and Control Center*

The ABCCC provides flexibility and control for tactical air missions and ensures the ATO is implemented. It normally serves as an extension of the combat operations division of the TACC or as an airborne ASOC. The facility is a self-contained module carried aboard a specially modified C-130 aircraft (a number of external antennas are mounted to accommodate the C² radios). The ABCCC can handle only procedural control; it cannot perform radar coverage. Radar coverage is provided by the AWACS. [Ref. 12:p. 8]

B. COMBAT COMMUNICATIONS

Where the TACS has a mission defined in terms of command and control, combat communication's mission is to provide the last "C" in C³ to facilitate C² in the deployed environment. In essence, combat communications provides the backbone or infrastructure which will link the locations together within a theater, and even across theaters as needed [Ref. 14]. Figure 10 shows an overview of a deployed tactical communications network including the TACS and combat communications equipment. The elements within the TACS were explained in previous sections.

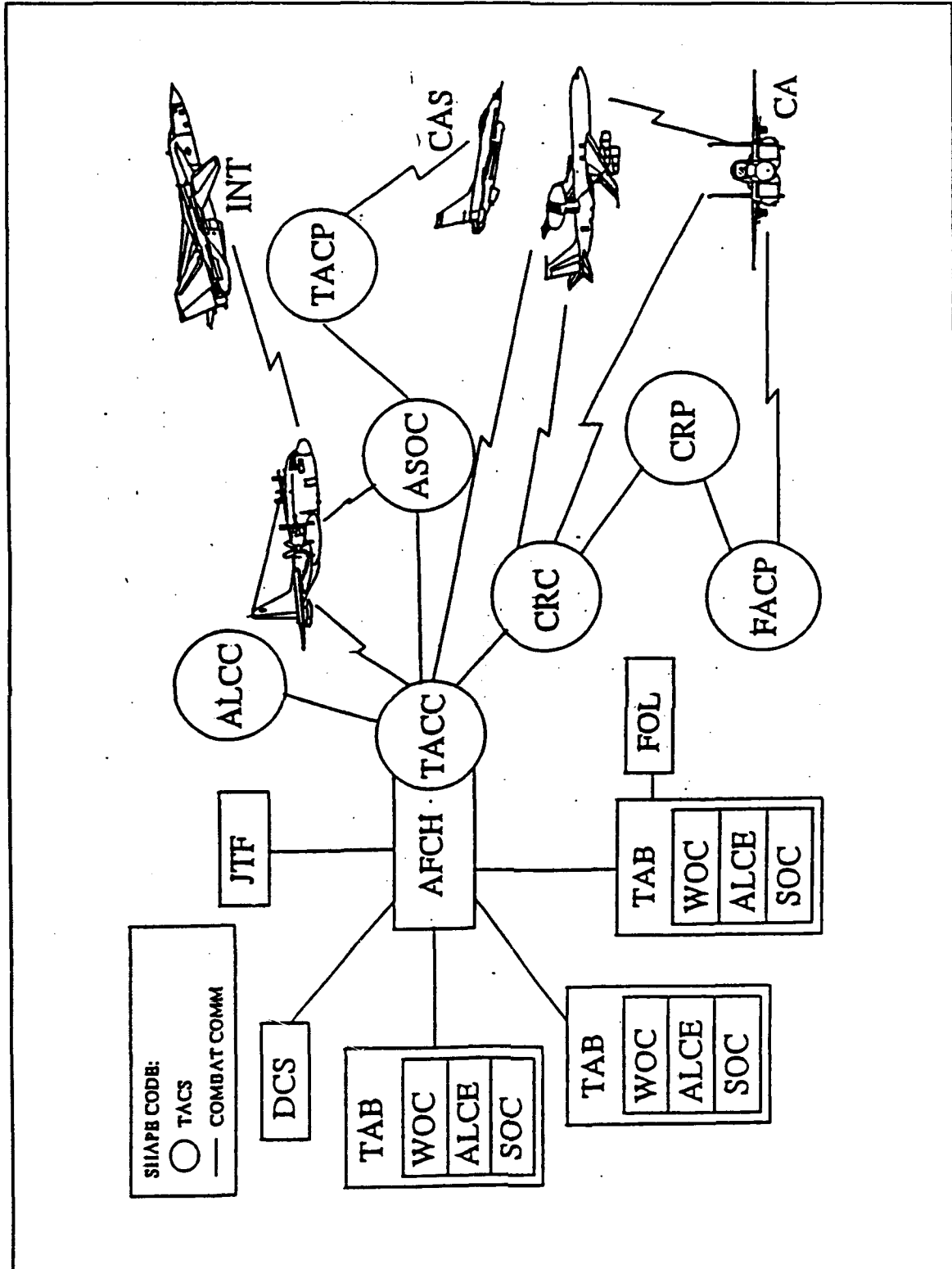

Figure 10: Deployable Tactical Communications [Ref. 15:p. 22]

Combat communications provides the backbone from the Air Force Component Headquarters (AFCH) to the tactical air bases (TAB's) and into the Defense Communications System (DCS). Where the TACS relies upon mission-unique equipment (radars and display scopes, for example) for its C² mission, it uses much of the same equipment as combat communications for its links between sites. These links, as shown in Figure 10, are usually provided by the joint tactical communications (TRI-TAC) and ground mobile forces satellite communications (GMFSC) equipment.

C. TRI-TAC

TRI-TAC is the acronym given to the joint tactical communications program and the equipment procured under it. The program evolved out of interoperability problems experienced by U.S. forces during the Korean and Viet Nam conflicts. In the early 1960's, the U.S. participated in an allied research effort with Australia, Canada, and the United Kingdom called Mallard. The intent was to develop an allied communications capability based upon evolving digital technologies. In 1969, the Congress mandated that the U.S. pull out of the Mallard effort to focus upon U.S. joint-service interoperability. Even though Mallard never provided any hardware, it did generate a great deal of technical information which would serve as the foundation for TRI-TAC. [Ref. 16:p. 15]

DoD Directive 5148, May 1971 created the TRI-TAC program and office. This program was intended to create a new family of multi-service, interoperable, digital-switched equipment that was totally compatible across the family and with existing equipment. To do this, common equipment items were divided among the services, who

acted as the single development and procurement agent for that item. The major objectives of the TRI-TAC program according to the DoD charter were:

- Achieve the necessary degree of interoperability among tactical communications systems and other DoD telecommunications systems
- Place in the field in a timely manner new tactical communications equipment required by the armed forces to perform their mission and which reflected the most effective technology
- Eliminate duplication, where feasible, in the development of service equipment, and
- Perform the above in the most economical manner

The TRI-TAC office, specifically the director, was tasked to act as the systems architect and principal planner for the TRI-TAC system. [Ref. 16:p. 16]

The equipment procured can be divided into six general categories: user terminals, switching facilities, control element, transmission facilities, multiplexers, and modems. By the late 1980's most of the major equipment had been fielded, and many pieces have evolved through internal equipment and software updates. Table 4 provides the description and nomenclature of the major pieces of TRI-TAC equipment by category. The multiplex and modem equipment is frequently referred to as digital group multiplex (DGM) equipment. The AN/TSQ-146 Multiplex Van is not a separate piece of multiplex equipment, but rather an assemblage of DGM equipment into a larger van that provides a patching and testing capability.

TABLE 4: TRI-TAC EQUIPMENT [Adapted from Ref. 16:p. 20]

TYPE	DESCRIPTION	NOMENCLATURE
User Terminals	Digital Subscriber Voice Terminal Digital Nonsecure Voice Terminal Advanced Narrowband Digital Voice Terminal Communications Terminal Lightweight Digital Facsimile	KY-68 TA-954/1042 CV-3591 AN/UGC-144 AN/UXC-7
Switching Facilities	750 Line Nodal Circuit Switch 150 Line Unit Level Circuit Switch 30 Line Unit Level Circuit Switch 50 Line Store and Forward Message Switch 12 Line Unit Level Message Switch	AN/TTC-39 AN/TTC-42 SB-3865 AN/TYC-39 AN/GYC-7
Control Element	Communications Nodal Control Element	AN/TSQ-111
Transmission Facilities	Troposcatter Radio Set Line-of-Sight Radio Terminal Set Line-of-Sight Radio Repeater Tropo-satellite Support Radio Fiber Optic Interface Unit	AN/TRC-170 AN/TRC-173 AN/TRC-174 RT-1492 AN/TAC-1
Multiplexers	Multiplex Van Remote Loop Group Multiplexer Remote Multiplexer Combiner Loop Group Multiplexer Trunk Group Multiplexer Master Group Multiplexer	AN/TSQ-146 TD-1233 TD-1234 TD-1235 TD-1236 TD-1237
Cable Driver Modems	Group Modem Low Speed Cable Driver Modem High Speed Cable Driver Modem Remote Loop Group Multiplexer Cable Driver Modem Low Speed Pulse Restorer High Speed Pulse Restorer	MD-1026 MD-1023 MD-1024 MD-1025 TD-1218 TD-1219

A word about equipment packaging is in order here. Terminals, multiplexers, and modems are usually man-portable devices, ranging in size from a desk telephone to a desktop personal computer, and less than 40 pounds. Switching, control, and transmission facilities are usually integrated into their own shelters which require the use of mobilization equipment and trucks to move them. The Air Force uses the S-280 and S-250 shelters for this equipment. The S-280 is about 7' x 7' x 14' and can weigh up to 10,000 pounds when fully configured. The AN/TTC-39, AN/TTC-42, AN/TYC-39, AN/TSQ-111, and one version of the AN/TRC-170 use the S-280 shelter. The S-250 shelter is sized to fit in the bed of a standard pick-up truck, and can weigh up to 6,000 pounds when fully configured. The trucks that carry this shelter are modified to handle the extra weight. A smaller version of the AN/TRC-170 uses the S-250 shelter.

D. GROUND MOBILE FORCES SATELLITE COMMUNICATIONS

The ground mobile forces satellite communications (GMFSC) terminals are not formally part of the TRI-TAC program, but are complementary since TRI-TAC does not include any satellite communications equipment. The Air Force uses two GMFSC terminals, the AN/TSC-94A and the AN/TSC-100A. Both use super-high frequency (SHF) radios, but the 100A is a larger, multi-carrier frequency version with greater built-in redundancy. The 100A's are frequently used as "hub" stations, with the 94A's acting as "spokes" and extending the network. Two antennas are available for use, the standard 8-foot dish or the higher gain 20-foot dish. The GMFSC terminals use the same shelters

as does TRI-TAC. The AN/TSC-100A is housed in an S-280 shelter, and the AN/TSC-94A uses the S-250.

Figures 11 to 14 show representative connectivity diagrams for how the TRI-TAC and GMFSC equipments are used to support the tactical air base (TAB) and air force component headquarters (AFCH) in the near- and far-term.

E. SHORTFALLS AND TRENDS FROM DESERT STORM

The conflict in the Middle East affords an opportunity to study how deployable systems worked under operational use, as well as a chance to view the larger management processes that occur above the theater level. While not exhaustive, four areas are listed below.

1. Phasing of Equipment Arrival

With an initial emphasis on getting a deterrent presence in theater, the communications equipment needed to eventually manage that presence was considered a low priority for use of airlift assets. Only after discussions among senior officers to alert commanders that they would not be able to control their forces without the supporting communications equipment did the priorities move up. But it was still several weeks before the larger pieces of equipment arrived. Although the Time Phased Force Deployment List (TPFDL) is intended to iron out these details in advance, allocation of airlift assets was conducted on an ad hoc basis and was complicated by the non-modular, heavy equipment which needed to be transported. [Ref. 17]

TAB CURRENT (1991)

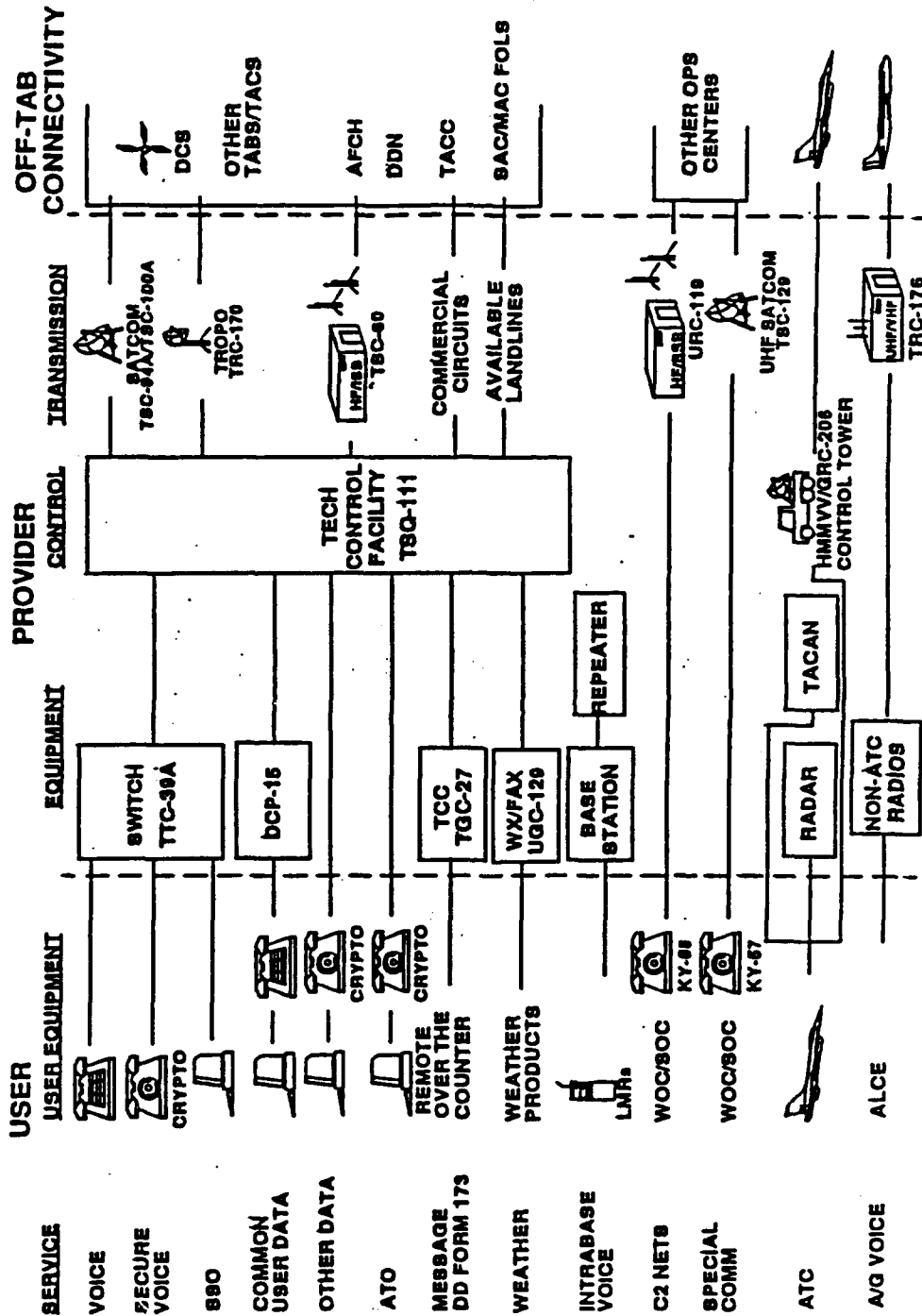

Figure 11: TAB Current (1991) [Ref. 15:p. 23]

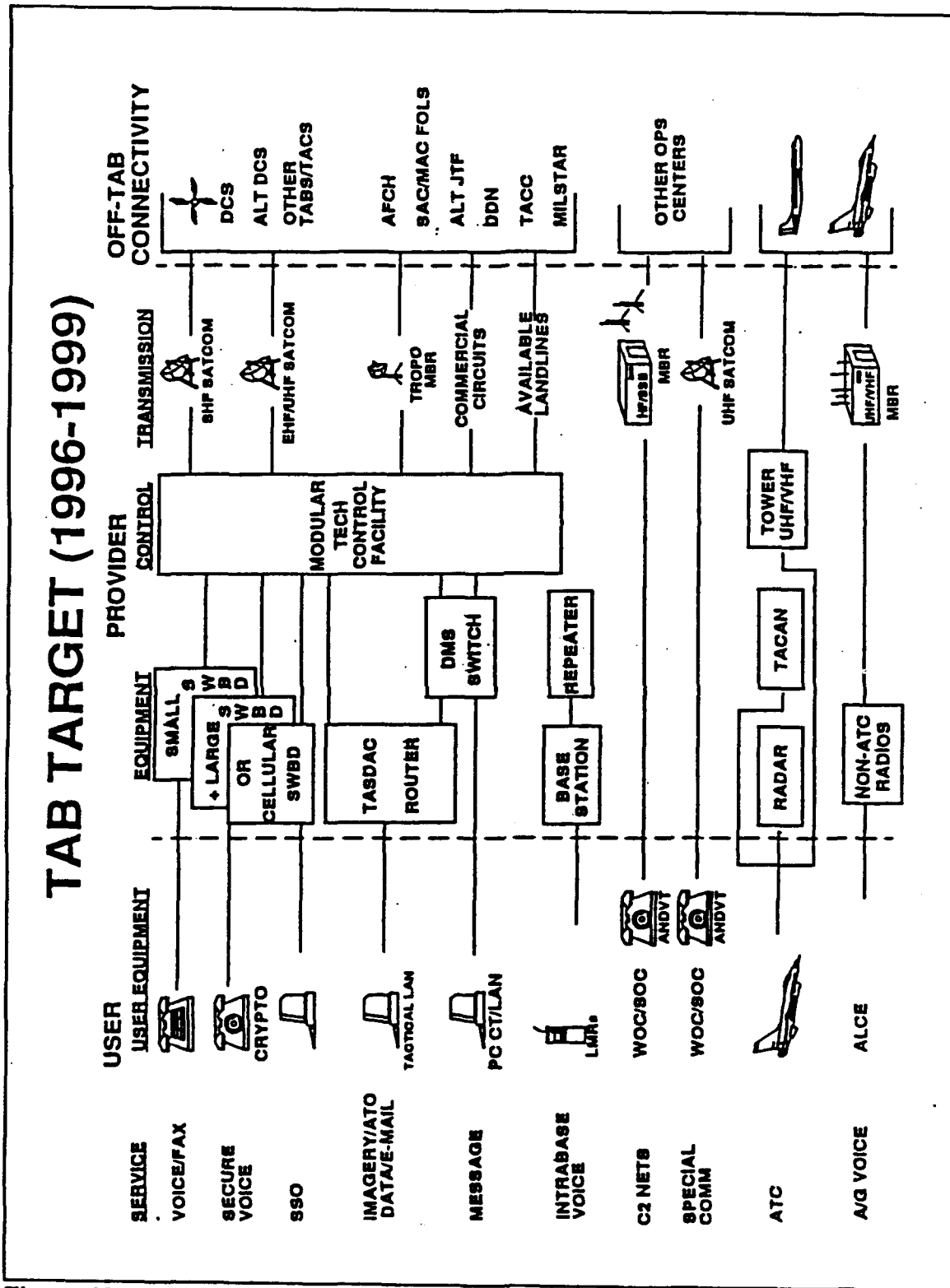

Figure 12: TAB Target (1996-1999) [Ref. 15:p. 25]

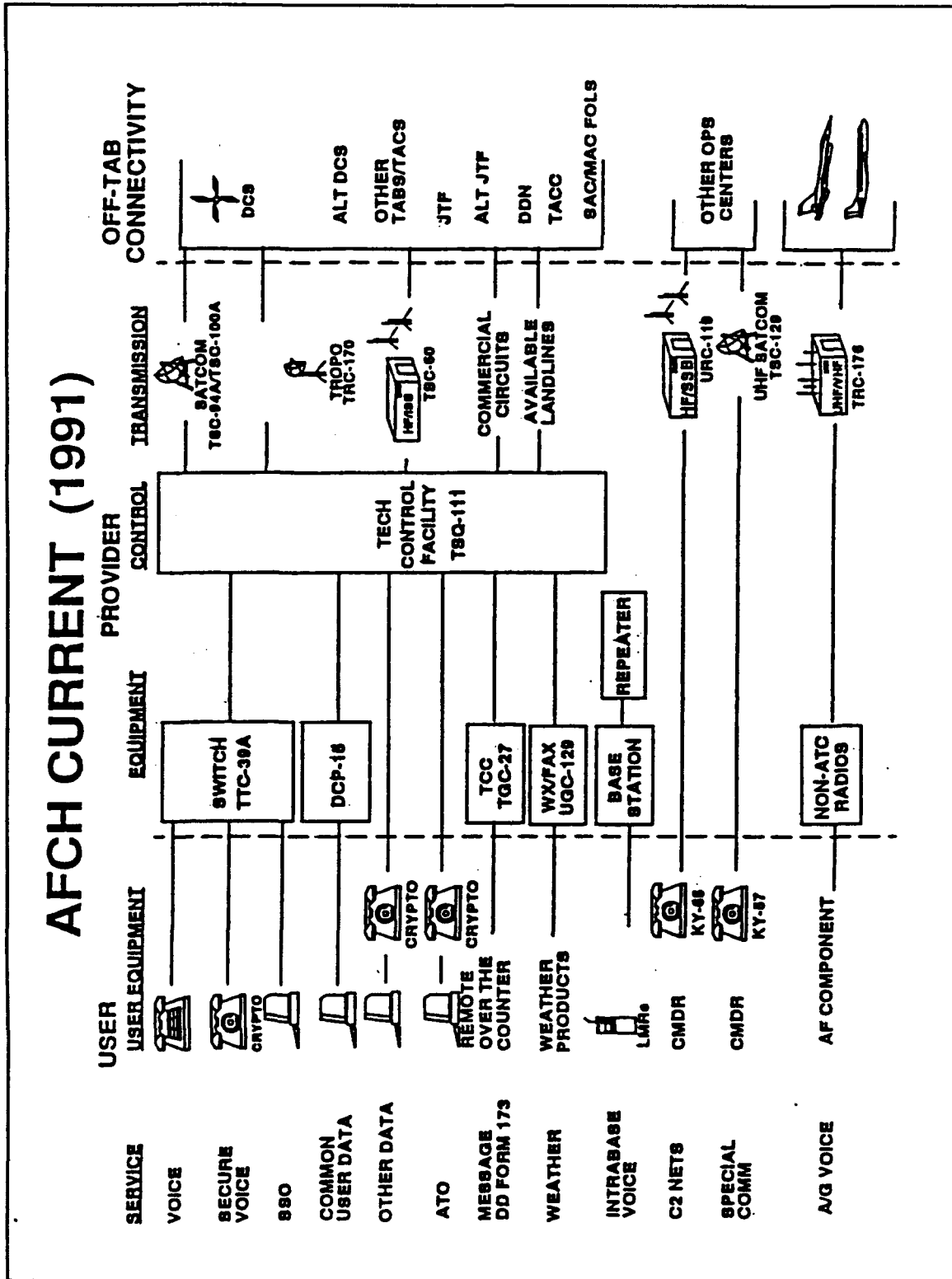

Figure 13: AFCH Current (1991) [Ref. 15:p. 27]

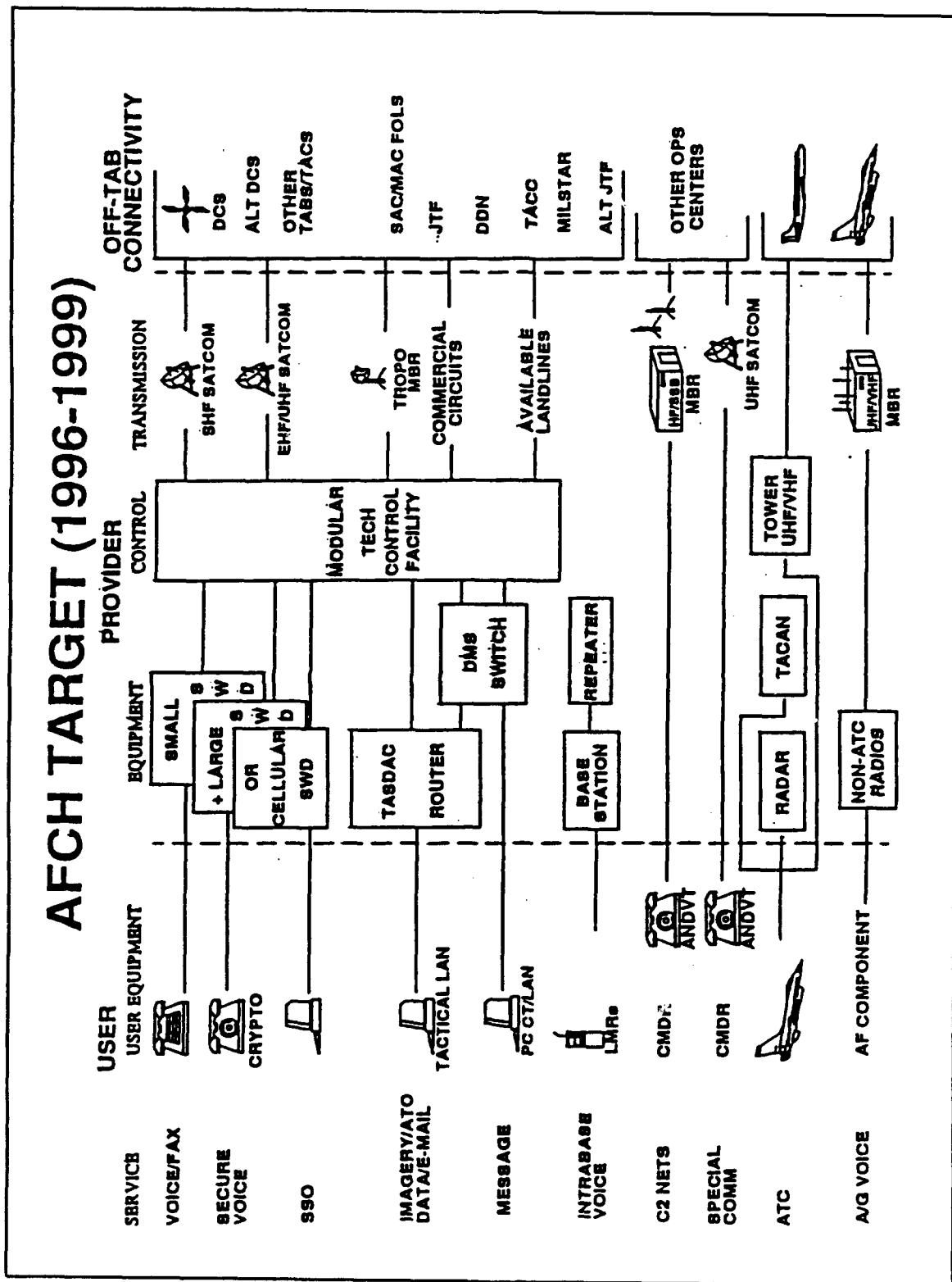

Figure 14: AFCH Target (1996-1999) [Ref. 15:p. 29]

2. Strategic/Tactical Interface

This area has been, and continues to be, a problem when deployed communications equipment attempts to interface with fixed systems such as the DCS [Ref. 16:p. 28]. This stems from the different environments each system operates within, and the standards and test procedures each accordingly employs. In fact, of the 24 trunks between the U.S. and the Middle East, 18 did not work properly until 21 Dec 90--four months after intended activation. [Ref. 18]

3. Satellite Communication Dependence

The network established for Desert Storm relied greatly upon satellite communication (SATCOM) for its success. This medium provided the capability to grow and reconfigure under dynamic conditions which the network architects desired. [Ref. 19:p. 42] SATCOM was the only feasible way to distribute the network over the vast theater of operations and provide the connections back into the DCS. Terrestrial communications were used to extend the network further from "spoke" sites and served to provide the critical redundancy between sites already connected via SATCOM. [Ref. 19:p. 43]

4. Paradigm Shift in Operations

The current command structure for air operations places most of the command and control functions physically on the ground. However, during Desert Storm, the roles reversed and much of the C² of air operations took place in the air. The primary platforms involved were the Airborne Warning and Control System (AWACS), the

Airborne Command and Control Center (ABCCC), the Joint Surveillance and Targeting Attack System (Joint STARS), and Rivet Joint (a signals intelligence aircraft). This is a significant departure from the historical command and control role for aircraft as primarily sensors. [Ref. 20] This evolution in operations could be shifting the Air Force toward a new de facto C² architecture which could provide unparalleled capability, but will also force designers to deal with growing complexities and associated issues.

F. SUMMARY

The Tactical Air Control System and combat communications comprise the majority of what the Air Force calls tactical communications. Both systems use the TRI-TAC and GMFSC equipment to provide the communications links needed in the deployed environment: TACS for the airspace management and control missions, and combat communications for theater connectivity. Desert Storm presented challenges to deployable systems from both a technical and conceptual standpoint. Not only was the actual equipment put to the test, but the entire process of providing command and control has been opened up for examination.

V. CENTRAL ISSUES AND CONCEPTS

This chapter is not intended to "solve" the problems currently facing communication systems planners, but is an attempt to lay out a selection of variables for consideration so as to help "define" the problem. Due to the interdependence of the variables, a systems approach was considered appropriate as an analysis method. Every attempt was made not to reduce a very complex problem into simple, toy-problem terms, but more into chunks that illustrate the interdependence of the elements.

A. DEFINITION OF C²

At the core of any military communications issue should be the reason that communication is needed: to facilitate and support command and control (C²) of the forces and means of war. JCS Publication 1-02 provides a good starting point for C² from which to build upon.

1. JCS Pub 1-02 Definition of C²

The exercise of authority and direction by a properly designated commander over assigned forces in the accomplishment of the mission. Command and control functions are performed through an arrangement of personnel, equipment, communications, facilities, and procedures employed by a commander in planning, directing, coordinating, and controlling forces and operations in the accomplishment of the mission. [Ref. 21:p. 77]

Perfect C² implies some level of omnipotence on the part of the commander, the ability to have all the desired information available to make a decision at the time of the commander's choosing (what he needs to know when he needs to know it).

2. C² is Information Centered

Information, as opposed to raw data, is what allows a commander to make decisions that will favorably affect the outcome of war. Paul Stares said in his book

Command Performance:

The contribution of command and control to military effectiveness derives from the use of its basic commodity--information. With accurate information, uncertainty about the surrounding environment can be reduced and decisions affecting the readiness, movement, and application of military force can be taken with a clearer understanding of the likely costs and benefits. If processed and delivered promptly, information can also provide more time for these decisions to be taken and, moreover, implemented with successful results. [Ref. 22:p. 19]

Decisions made without the benefit of information are at best lucky, and at worst disastrous. As Stares points out, to be of any value, this information must possess at least two qualities: timeliness and accuracy.

3. Timeliness and Accuracy

Perfect information should, by implication, possess both timeliness and accuracy. In reality, perfect information is not available to the commander. In general, accuracy and timeliness are proportional, where highly accurate information can take a very long time to prepare and confirm. Under dynamic conditions, this situation would not prove helpful. As such, a balance between the two qualities is desirable. Some amount of accuracy is traded off to allow the information to get to the commander in time to be of value. Determining how "good" is "good enough" and trying to quantify the trade off between timeliness and accuracy is beyond the scope of this effort. However, assignment of a confidence level to information is one way to provide an indication of how sure the source is about the accuracy of the information.

There is an economic concept called the "Law of Diminishing Marginal Returns" where, as additional resources are used, the incremental increase in output declines with higher levels of resource usage. Beyond some point, there is zero or negative marginal return for resources used in the production an output. Using the above case as an example, it may be possible to attain a 90% confidence for accuracy of information within 1 hour, but to improve the confidence an additional 5-9 percentage points (to 95-99%) may require an additional 4 hours. Figure 15 illustrates this point in graphic form.

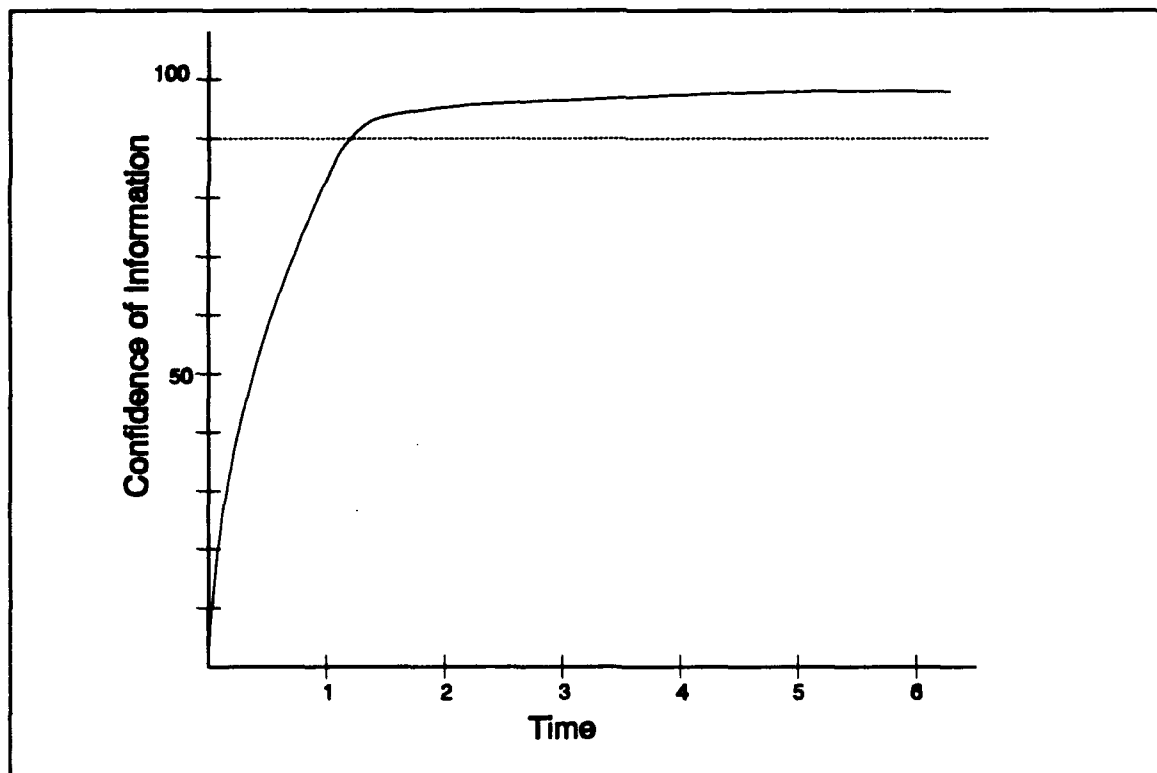

Figure 15: Confidence in Information Curve

The shape of the curve is due to the underlying technologies and processes which are used to obtain and confirm the information. A relatively fast sensor may indicate the occurrence of an event within a class of events, while different sources may be consulted to further narrow the event. All of this confirmation takes time, especially where manual intervention is needed. For many applications, the 90% confidence may be sufficient to base decisions upon. Policy, sensitivity of decisions, and commander's experience will likely shape the thresholds used in practice.

What this information allows a commander to do is outperform the opponent in real-time under dynamic conditions. Colonel John Boyd illustrated this concept well in what is called the "O-O-D-A" loop.

4. Boyd's O-O-D-A Loop

Colonel Boyd, a former USAF pilot and aerial combat theorist, developed this model originally for maneuver warfare. It is used here to simplify and illustrate the C² process. According to James Fallows:

This 'loop' consists of cycles of *observing* (O) the enemy's actions, *orienting* (O) oneself to the unfolding situation, *deciding* (D) on a counter, and then *acting* (A). The principle is that the side which can complete these cycles more quickly will ultimately prevail [Ref. 23:p. 19]

As seen in Figure 16, Boyd's model does not show the adversary's O-O-D-A loop and the environment that contains both. Dr. Joel Lawson and Prof. Paul Moose extended and adapted Boyd's model to include the adversary's loop in the overall environment, as seen in Figure 17 [Ref. 24:p. 187]. Although different terms are used, the functions remain essentially the same.

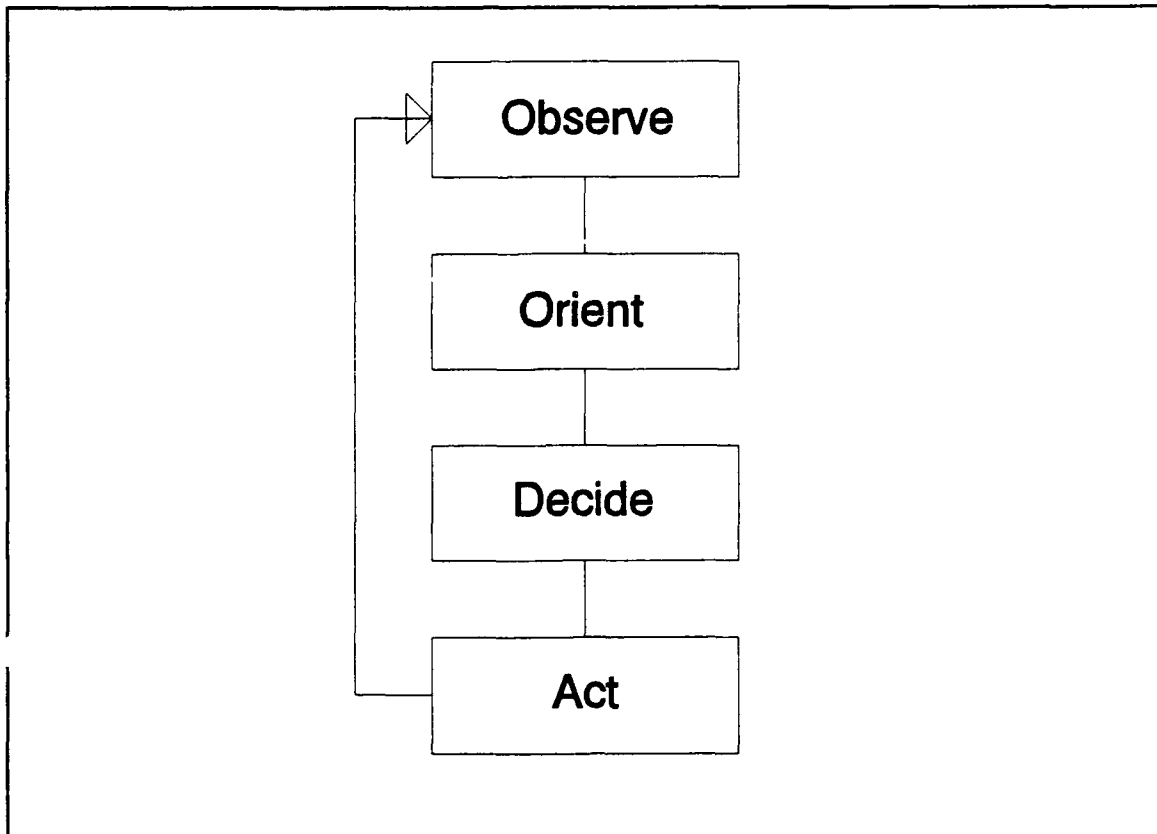

Figure 16: Boyd's O-O-D-A Loop

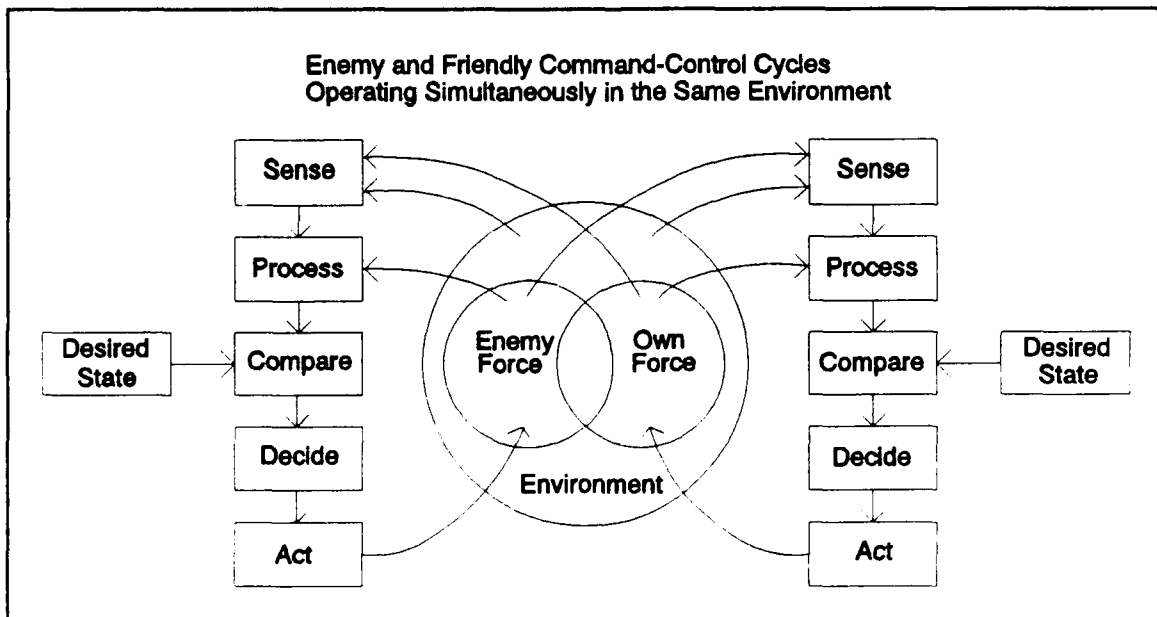

Figure 17: Lawson's C² Model

The balance of this chapter is concerned with the issues and concepts that form the basis for designing architectures and systems. Just as the Chief of Staff of the Air Force (CSAF) asked his staff: "...how would we set up comms for a Desert Storm like operation if we were free to do it the way we want, starting from a clean sheet of paper?" we can also build from the ground up. [Ref. 15:p. 31]

B. POLICY AND ASSUMPTIONS

We cannot truly start with a blank sheet of paper. The role of policy is to provide the planning guidance needed to shape and narrow the feasible alternatives. Viewed in terms of operations analysis, policy helps define the objective function and constraints used to obtain an optimal solution to a problem. For example, the problem might state:

Minimize: Cost
Subject To: Capability $\geq X$
Airlift Requirements $\leq Y$
:
Personnel Requirements $\leq Z$

Or the problem could be of the form:

Maximize: Capability
Subject To: Cost $\leq S$
Airlift Requirements $\leq Y$
:
Personnel Requirements $\leq Z$

The above illustrates different ways to state the problem. The bottom line is to provide an acceptable level of capability for a specified number of dollars. (It should be noted that the problem as stated may or may not have a feasible solution). The difficulty

arises in trying to write a model which will allow an analytical solution. Many variables will of necessity be constrained, i.e., money that can be allotted or current airlift available. However, by holding the other values constant and letting the variable of interest run unconstrained, the model can return a value that will satisfy the constraints as written. While the chosen level of capability may require three times the gross national product or more airlift than currently exists in the world, this can still be used as a planning tool for model refinement or to examine the underlying technologies with greater scrutiny.

Given that previous studies and guidance are leading towards smaller, lighter, more modular equipment, and greater interoperability between services and the commercial sector, what issues and approaches will shape an integrated transition into the next century? Due to the complexity of C² systems (organizationally, technically, or the human element involved) it may never be possible to enumerate a "best" solution to C² needs. However, through an illustration of the trade-offs involved in differing approaches to solving parts of the system, it may be possible to choose a better system than if no analysis were performed. Because the initial assumptions or conditions have such a great impact upon the direction the system planning will take, it is helpful to review some of the current high level guidance.

1. Joint Publication 1

If planners are to design systems to perform in a wartime environment, they must know what the expected environment will be. However, inconsistencies exist between high-level documents, and even within documents. Joint Publication 1 states:

...the arena of our potential operations is the entire planet, with its surrounding aerospace, from the ocean depths to geosynchronous orbit and beyond. We must be prepared to defend our national interests in every type of terrain and state of sea and air, from jungles, deserts, and tropical seas to polar ice caps. The US Armed Forces face the challenge of mastering multifaceted conditions, unlike nations whose military forces can concentrate on a more limited range of environments. Indeed, the ability to project and sustain the entire range of military power over vast distances is a basic requirement for the US Armed Forces and contributes, day in and day out, to the maintenance of stability and deterrence worldwide. [Ref. 25:p. 2]

In contrast, the planning emphasis appears to be shifting toward the crisis and limited objective warfare (CALOW) environment in the Copernicus architectural document, as shown in Figure 18. As will be seen next, the C² Functional Analysis and Consolidation Review Panel (FACRP) states we should plan for general nuclear war and focus attention on the CALOW environment. Any system designed without a clear vision of its intended use will likely be compromised in some way.

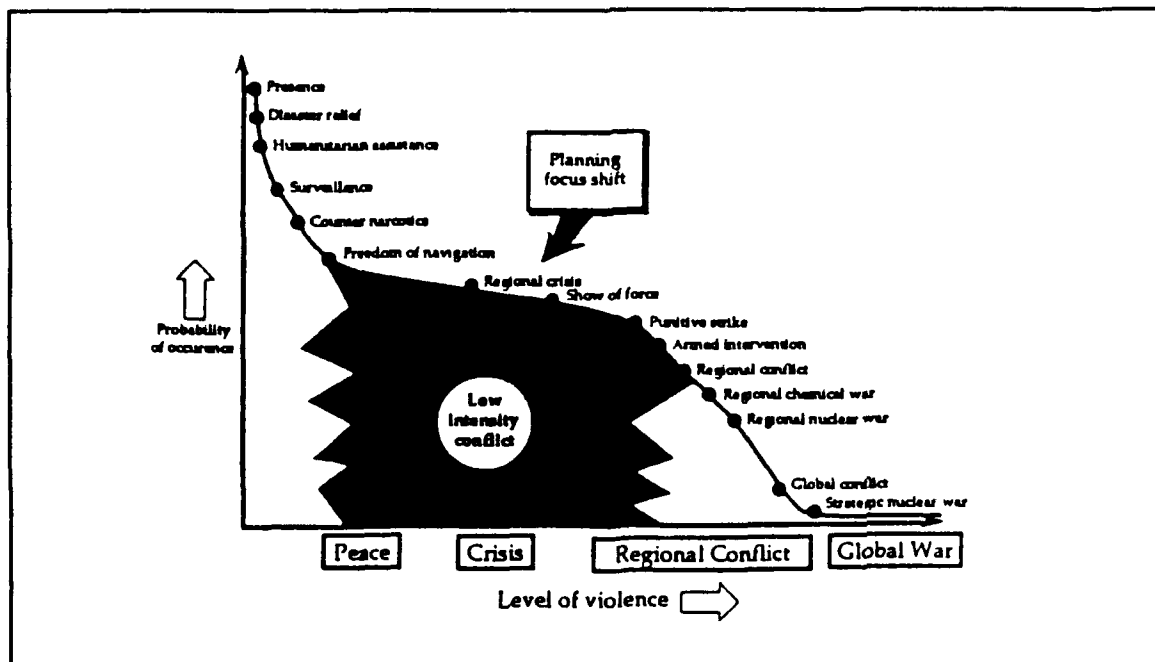

Figure 18: Operational Continuum (1990-Beyond) [Ref. 26:p. 2-4]

2. FACRP

With a goal of finding more efficient ways to meet the mission, the FACRP reviewed national strategy and policy to assess C² operational requirements in support of the National Command Authorities (NCA) and Commanders in Chief (CINCs). Their purpose was to "...identify cost-effective approaches to satisfying DoD-wide C² requirements, specifically through consolidation of capabilities where such action makes operational and economic sense." [Ref. 27:p. 2] The FACRP went on to list the economic and strategy changes, and the C² drivers which will shape and impact future architectures. These lists are shown in Tables 5 and 6. They also found that the current DoD C² structure would not provide the long-term efficiencies needed, and suggested a new C² structure would have the features below:

- A consolidated, DoD-wide, global C² infrastructure
- A greater emphasis on joint task forces as the principle tactical operational forces
- Centrally managed operational support [Ref. 27:p. 13]

Even though much of the above information is consistent with the findings from the studies reviewed in Chapter II, consistency of policy or planning guidance is still a problem.

TABLE 5: ENVIRONMENT AND STRATEGY CHANGES [Ref. 27:p. 3]

Resource Availability

- US budget constraints
- Decreasing motivation to fund at Cold War levels
- Decreasing defense funding advocacy among major allies

The Soviet Threat

- Continuing, improving strategic forces
- Reduced conventional threat to Europe, reduced power projection capability
- Soviet political uncertainties

The Increased Regional Threat(s)

- Political and economic power shifts
- Insurgency, drugs, terrorism problems
- Availability, use of advanced weapons, including weapons of mass destruction

Strategy Changes, Force Posture

- Forward presence, but with reduced forces at fewer overseas bases
- Backed up by CONUS contingency and reserve forces
- Planned mobilization, if needed

Technology Advances

- High-lethality weapons (e.g., precision guided, chemical, biological)
- High-capability weapon delivery (missile and airborne) systems
- Increased use of space
- New information transmission, processing, support capabilities

TABLE 6: C² DRIVERS [Ref. 27:p. 7]

Streamlining and Consolidating

- Reduce C² personnel
- Consolidate U & S organization elements
- Eliminate redundant systems where possible

Risk Management and Acceptance

- Maintain deterrence, prepare for nuclear war
- Determine size, nature, and location of forces
- Determine minimum essential capabilities
- Standby contingency capabilities
- Mobilize if necessary

Strategic Agility

- Focus on low end of the conflict spectrum
- Deter, fight regional powers if necessary
- Support forward-deployed forces
- Support rapid deployment and redeployment
- Interact and interoperate with allies

Force C² Interoperability

- Technical standards and protocols
- Applications: processing, interpretation
- Procedures
- Command response, common understanding

Force and C² Modularity

- Joint and combined interoperability
- Relocatable/mobile modular assets
- Building-block planning tools

Technology

- Networking
- Multilevel security
- Automation, communications
- New sensing and reporting systems

3. The Next Step

As stated earlier, because the initial assumptions or conditions have such a great impact on the direction system planning takes, they should be clear and consistent. This forms the basis of the "givens" from which future trade-off analysis can occur.

C. PLANNING AND DESIGN CONSIDERATIONS

Chapter II reviewed three studies which laid out a general direction of smaller, lighter, more modular and interoperable equipment as goals for any new deployable TBM equipment the USAF might purchase. In addition, C⁴I for the Warrior mentions a goal architecture where all systems are connected to an ether. While either concept is not hard to visualize as a possibility in its end form, no roadmap exists to join what is currently in the inventories with the goal architectures. Many factors may make it difficult, but not impossible, to realize these goals. The resolution of the areas explored below are considered essential by the author for a cohesive deployable architecture to emerge.

1. Type of Conflict

It is not clear from policy exactly what type of warfare the military services should realistically prepare for. The conflict spectrum presented from Copernicus implies a planning shift, as does the FACRP. Planning should be consistent with the probability of occurrence, but must also factor in the "cost" of being unprepared, even for some unlikely event. Since the needs of each type of event will be different, the broader the range covered (on the spectrum), the greater the compromise in capability for each particular application.

2. Modularity

Modularity affords greater flexibility in terms of response and capability sizing at the initial stages of a deployment. These modules should be compact and able to be configured to meet the needs of a contingency force. Over time, however, if the network becomes large, the advantages of the modules could diminish (due to economies of scale) but could still be viable if the network is somewhat dynamic.

How modular to be is also a question, since many functions will still require specialized equipment. For example, a telephone switch and a radar are very different functions and would likely require different classes of equipment. The family of modules as well as what is expected of them must be considered carefully.

3. Statement of Requirements

Before a communications structure can be developed, requirements must be determined. As a result of post-Desert Storm tasking, the USAF (as well as JIEO and other organizations) have drafted architectures which now serve as the design model for developing the supporting communications structure [Ref. 28]. These architectures are helpful in showing which activities are coupled and which are not, but do not show the relative capacity that would be required between entities.

4. Sizing Requirements

The capacity requirements of the links that connect the various entities, as well as the direction of flow (A to B, B to A, or both) are needed to properly size the network.

The USAFTC study had this to say about sizing:

While communications connectivity requirements are understood (i.e., who needs to talk to whom) the expected utilization or circuit loading is not well characterized. Without this data, the degree to which circuits can be shared in a demand assignment or packet switching environment cannot be assessed. [Ref. 4:p. 9]

To illustrate this, the Air Force Communications Command's Standard Systems Center eventually provided a deployed data network (in support of Desert Storm) capable of handling in excess of 200,000 supply and maintenance transactions from 50 sites each day--linked back to a host computer at Langley AFB, VA by commercial satellite links at over 3 million bits per second (MBPS). But the planning for this network did not get off the ground until the first planes were on their way to Saudi Arabia. While the concepts had been explored earlier, testing was being accomplished to validate it during the build-up of forces. Even after the network was installed and became operational, it continued to grow as demands increased. [Ref. 29:p. 58] This situation is likely to be the norm in the future, especially as data networks are increasingly used to support the warfighters.

Understanding what needs to flow between entities will help quantify the size of the links needed. Not all information needs to go in every direction. Copernicus uses the ideas of "push-pull" to show this. "Push" could be information which is broadcast from a central source (such as intelligence information from national assets), while "pull" would be queries or requests made for information from a central database. In the "pull"

mode, the user only draws in the information of immediate interest. [Ref. 26:p. 2-8] Of course, actually determining the size of these links will be dependent upon the service increment chosen as the basic building block. This is one of the roles that standards play.

5. Standards

Standards provide a common reference point for determining required capacity of service (how many channels of a given size), and they define the technical parameters that equipment must conform to in order to connect to the network. While deployable systems use a digital channel based upon a 16 or 32 kilobit per second (KBPS) rate and the continuously variable sloped delta (CVSD) voice modulation scheme [Ref. 16:p. 19], modern fixed systems use a 64 KBPS rate and the pulse code modulation scheme, commonly called a DS-0 channel. The DS-0 channel is part of the larger North American Multiplexing Scheme which includes DS-1 and DS-3 (also referred to as T-1 and T-3) at 1.544 and 44.736 MBPS. [Ref. 30:p. 39] Adopting these standards would ease the strategic/tactical interface problem highlighted in Chapter IV, and allow the use of modern and highly reliable commercial equipment. This would also afford deployed users the same level of service they now enjoy in-garrison. In fact, T-1 service to the customer premises is now common, and T-3 services are appearing rapidly as more tariffs are approved [Ref. 31:p. 82]. The down side is an initial investment in new equipment, but this has in recent years become relatively inexpensive as commercial standards and technology have outpaced military ones.

6. Transportation and Phasing of Equipment

More modular equipment should be easier to move (less air cargo space required) at the onset of hostilities since only the required capabilities need to be sent. Recall from Chapter II that the initial emphasis for Desert Storm was on getting firepower into theater, not necessarily support equipment. Under the current methods, communications support for an airwing is provided from organizations outside the wing. While this works well for sustainment, it is not responsive to rapid deployment needs or contingencies. As such, Tactical Air Command (TAC) is exploring a wing-integral communications concept that will deploy with the wing and provide all essential communications for the first two weeks. After that, the sustaining equipment and personnel would assume the communications functions. [Ref. 29:p. 57]

While this approach could help alleviate some of the phasing problems that arose during Desert Storm, new issues are brought forth. If different people and equipment will be responsible for the same support, but at different times, how will the handoff be accomplished? If the initial package becomes part of the sustaining force, it must be interoperable and compatible with it. Modular design would help ensure the follow on forces would be able to add to the capability gracefully. If equipment will be "swapped out," the network must be designed in such a way as to ensure an orderly transition with little or no outage time.

7. Dispersal and Distributed Processing

Dispersal and distributed processing appears as a goal in many architectural documents (recall TC²-21 and the Air Force C-CS Architecture, for example). This

concept spreads equipment and personnel over a greater geographic region to provide a high degree of physical protection to both. Embedded in this concept is a very high degree of interoperability and conformance to standards. Demands on the network infrastructure would increase since each dispersed location must have a connection into the network. But it may be possible to reduce or eliminate some of the transportation requirements through pre-positioning. In a position paper on tactical C³I architectures in support of Global Reach, Captain Duncan McKenzie advocates the construction of three Global Reach ground entry stations; one on each coast of the United States, and one within the footprint of the Indian Ocean satellite [Ref. 32:p. 1]. McKenzie's premise is that these ground stations could handle the "hubbing" function normally assigned to theater assets, so that the equipment actually deployed could be in direct support of a wing [Ref. 32:p. 7].

This is a departure from a traditional hierarchical approach to C², which he says works well for ground forces, but not for air forces (as they found out during Desert Storm). He attributes this to differences for ground and air forces in their C², intelligence, and logistics relationships. [Ref. 32:p. 2] Where ground forces are very hierarchical in structure, air forces tend to be more horizontal (at least for the support functions--the C² functions performed by the TACC would still remain hierarchical to retain centralized control). Wings deploy to a tactical air base, but get nearly all their support from outside the theater. McKenzie points out that only two C² circuits originate inside the theater, scramble (used to "scramble" alert aircraft toward targets) and CAFMS (computer assisted force management system, used to disseminate the ATO). Supply and maintenance

functions are remoted from U.S. bases, and intelligence and weather go direct to the wing via national sources. [Ref. 32:p. 3] He further asks: "Since the above services require little or no intervention by higher echelons within a theater, why not adopt a tactical network architecture that simultaneously provides intra-theater C² connectivity and direct inter-theater connectivity between deployed air forces and their CONUS based sources?" [Ref. 32:p. 4] His concept would be to provide the ground stations with connections to networks for national information, trunks to other ground stations for inter-theater capabilities, and switching facilities for intra-theater needs. A user would reach the ground station by satellite, and would be patched to the path their needs dictate. Figure 19 shows an example layout for a ground station. Note that users can be patched direct to another user (a dedicated path), or switched, and can be routed within the theater, or into any of the global networks that the ground station can access.

D. SUMMARY

There are a great many issues which must be considered if an integrated approach to providing deployable communications is to be taken. In some ways, the way in which the services are being provided is evolving faster than the present structure can accommodate. Some issues focus on the technical aspects of getting equipment to talk to and understand each other, while others are more related to planning considerations, while others still examine the more fundamental question of how services will be provided. All are important if balance and perspective are to be maintained.

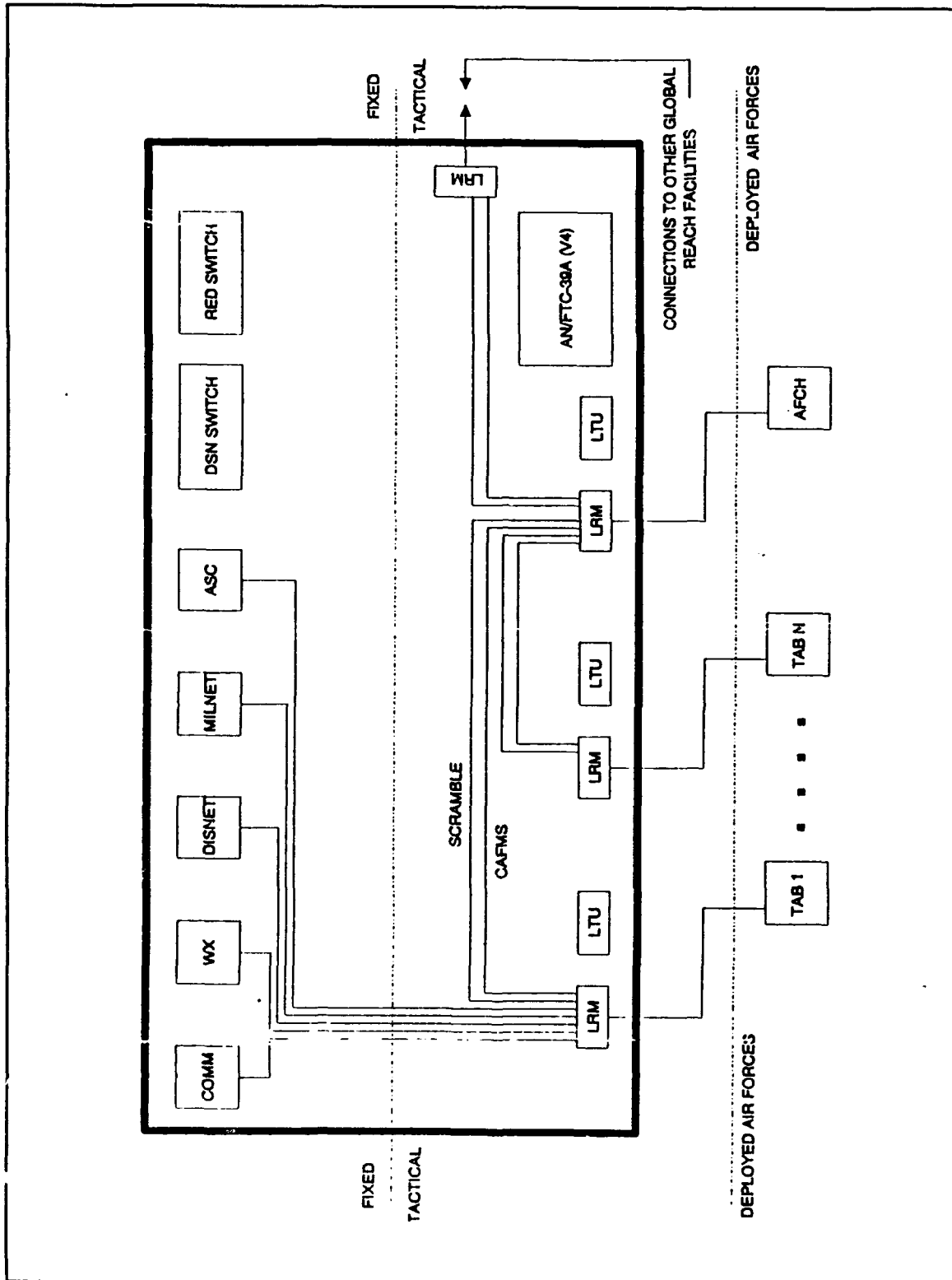

Figure 19: Example Global Reach Ground Station [Ref. 32:p. 11]

VI. CONCLUSIONS AND RECOMMENDATIONS

A. CONCLUSIONS

There has been a great deal of effort at many levels to get a handle on the problems that face deployable systems. These efforts should be acknowledged for their attempts to quantify the problems and develop solutions prior to any of this author's own recommendations. Specifically, the studies reviewed, the after-action reports that followed Desert Storm, C⁴I for the Warrior, and the Functional Analysis Consolidation Review Panel (FACRP) all demonstrate that the technical problems are reasonably well understood and are solvable. The people behind these efforts are doing their best to take a very complex situation, one which crosses many functional boundaries, and meld it into a synthesized, cohesive whole. Their work has paved the way for better communications support for the warriors in the future.

Defining the goal and reaching it can be two different things, however. Where it appears the technical solutions are within reach, the mechanisms to implement those solutions may be cumbersome, or worse yet, non-existent. Integrated problem solving should include not only the technical solutions but also the addressing of the means to implement those solutions. The recommendations below serve as a starting point for getting some of these areas identified, and ultimately solved.

B. RECOMMENDATIONS

1. Assignment of Responsibility and Authority

Assignment of responsibility and authority has yet to be vested in a single focal point. The TBM study called for the creation of a "center of excellence" where architectural and technical expertise, as well as information on the TBM activities of other services, could be centrally located. [Ref. 3:p. 5] Although a General Officer Steering Group (GOSG) and working group have been established for TBM activities, these groups meet only periodically to resolve issues of concern and to set broad policy. Their charter is included as an Appendix for information purposes.

It is possible that the GOSG could act as a "board of directors" in guiding the TBM activities for the Air Force. However, it is not clear who the members of the "communications corporation" really are, what their responsibilities would be, and what the relationships between them would be. Following the lead set by DISA, focal points should be established for areas under the TBM umbrella. All of these would then report back to the TBM architect who would ensure overall harmony of effort. The TBM architect should also act as the Air Force focal point for joint activities regarding deployable communications.

Without a center of excellence to guide and shape the efforts of many agencies, the Air Force lacks the integration needed to ensure the findings of the studies are resolved. Research for this thesis revealed that many entities are developing independent architectures outside any broad umbrella structure which might require them to fit within [Ref. 33:p. 1]. On the bright side, actions are being taken by the new

architecture and integration division of the Joint Staff and the Office of the Secretary of Defense to eliminate duplication of effort and get control of greater than 300 architectures [Ref. 34:p. 1].

Where to place such a center and how to staff it are tough issues. Since the best operational perspective comes from people immersed in the operational environment, it may be possible to distribute the "center" geographically to gain expertise, while a core group would be responsible for the day-to-day management of affairs. The core group would manage the databases and coordination with other services and DoD agencies, and the designated, distributed focal points would be consulted and kept apprised through messages. For this system to work would require commitment on the part of the distributed representatives, and significant dialogue between them and the core group. The core group could be co-located with the Technology Integration Center, but to have any power, it must have the backing of Headquarters and the major commands (MAJCOM's) to carry out its mission. The expertise is available; it merely needs to be assembled and oriented toward the goal.

2. Follow-up Mechanism

Possibly at the heart of the above problems is the lack of any institutionalized follow-up procedures. The studies did not carry any directive authority to implement their recommendations, and the AFSB does not track the status of a study once completed [Ref. 35]. Nor does the sponsor, Air Force Systems Command (AFSC), have a means yet to determine the status of corrective actions taken. Although measures are being implemented informally at AFSC, follow-up action will still be sporadic for some time

to come. [Ref. 36] One responsibility of the TBM architect should be to gauge progress of the current system relative to the goals set forth from sanctioned studies.

3. Providing the Tools

a. Policy

Above all, clear policy is needed to guide the thinking of systems architects and engineers. The USAF's Global Reach, Global Power concept, where we desire the ability to respond quickly to any contingency, at any point on the earth, helps frame the problems to be solved. But this broad goal will be difficult to reach without breaking it into smaller pieces. It is still possible to respond to the challenges with a balanced suite of capabilities, where elements of the suite can be individually tailored to an appropriate mission. Policy should help determine the level of resources to use in realizing each element (based upon the threat and its probability of occurrence).

b. Models

Modelling and computer simulations can be valuable tools when resources are tight and risks are high. They allow many options to be examined without ever having to build a physical system. But to build these models and simulations requires good input data if reasonable results are to be expected. The Air Force has very little quantitative knowledge on network loading under stress [Ref. 4:p. 8]. Traffic analysis records from Desert Storm should prove helpful in developing realistic models for wartime communications requirements. However, caution should be exercised since the requirements may not be representative or scalable to other situations. An

understanding of the model will be critical to allow its evolution and growth as requirements and future needs dictate. This understanding will hopefully enable successful alterations, and provide greater confidence in the results of "what-if" analysis. These models would also be able to assist in trade-off analysis to highlight performance under various scenarios for the alternatives under study.

c. Trade-off Analysis

Within broad guidelines, many different architectures or systems would be equally capable of providing suitable service. While this is understood and exploited in weapon systems design, it seems to be a relatively new concept to tactical C² or TBM. A report by the E-Systems Corporation, conducted for the Electronics Systems Division of AFSC did attempt to determine the relative merits of a fully centralized versus fully distributed TBM approach [Ref. 38:p. 5]. This was an extension of the TC²-21 study, where the architectures were more fully developed and analyzed.

d. Artificial Intelligence

Expert systems and artificial intelligence can be used as database management and information decision tools. Recalling the concepts of push and pull of information, rule sets can be established to automatically route information to a commander. The rule set can be established in advance, and information placed into the ether can be tested against the rules. A simple example would be the use of key words, similar to the way information is cataloged for libraries. If the conditions specified are met, the information is sent to the commander. Otherwise, the information can be stored

for possible later retrieval. In this way, the commander can pre-filter incoming information so that only the information of interest actually arrives at his desk.

4. Conceptual Clarity

A recurring theme throughout this research has been a sense of confusion over how the different pieces of the puzzle fit together: the relationship between master plans and architectures, the relationships between different architectures (technical, functional, or those in support of a specific CINC or major command), and the relationships between architectures of different services. Logically, there should be a natural nesting of architectures from one level to the next. At the risk of over-simplification, Figure 20 shows how service architectures could be pieced together to form a CINC architecture. Further, using the Air Force segment, MAJCOM architectures can be joined to form the service architecture. The functional areas are represented as ellipses; they span the entire theater, and are represented within each service/MAJCOM architecture as well.

Sub-architectures can taken down to the desired level of detail, with the caveat that connections to other parts of the parent architecture remain clear. In a sense, the sub-architectures would be modules that plug into the parent architecture. Sub-architectures would also be cascaded to ultimately form the support structure required by the CINC.

Interoperability should be treated as an issue within an architecture, not as an architecture itself. Interoperability between systems is a design goal that can be served through clear architectural concepts. Interoperability concerns occur wherever a boundary is crossed. This could be between functional areas, services, or commands. Defining the standards at the boundaries, and enforcing compliance ensures systems will interoperate.

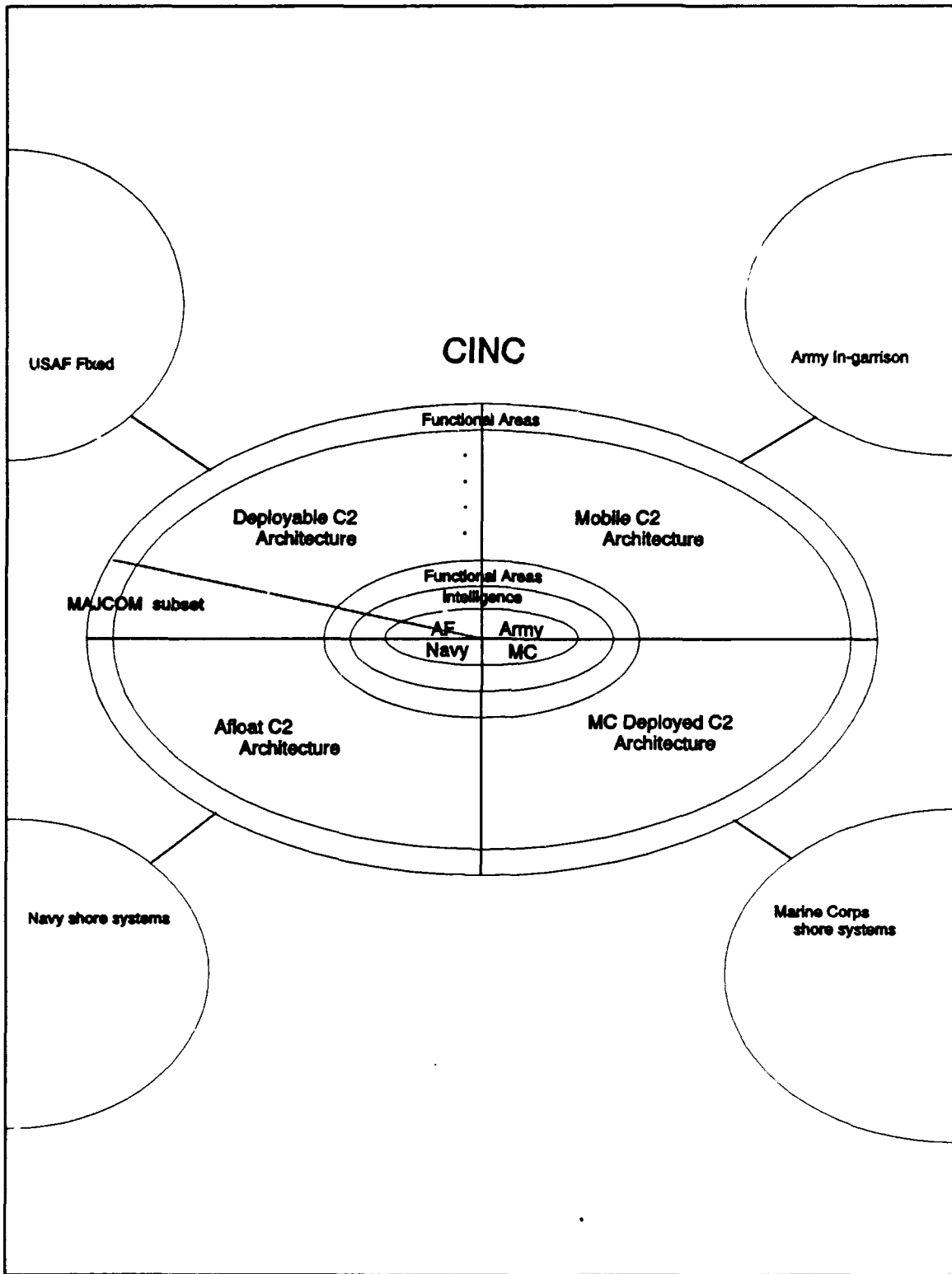

Figure 20: Architectural Concepts

A factor that compounds these conceptual problems is that the word "architecture" does not have a universal meaning within the DoD. JCS Pub 1-02 does not have an entry for architectures, and dictionaries are not always consistent with each other. This has led to many different interpretations of the word and corresponding confusion over what should be in an architectural document. [Ref. 38:pp. 2-3] A proposed definition is:

A guide or "blueprint" which outlines the shape and structure of a system, or group of systems. It provides a goal to build toward, and shows the boundaries between systems and the standards used at the boundaries.

The essential elements are structure and standards. It should be clear to anyone reading an architectural document what would be required for them to interface with it.

5. Systems Training

Part of the difficulties facing deployable systems may stem from a lack of training in "systems" themselves. As stated in Chapter I, systems are more than just the sum of their parts, and are characterized by interdependence of elements. Engineers and technicians need to understand the individual pieces of equipment, but maybe even more important is an understanding of how that piece of equipment contributes to the overall network, and the impact to the network if that equipment is dysfunctional. This is especially important since, as they progress in their careers, these same people will be responsible for designing and implementing new families of equipment.

C. THE MISSING LINK

Integrating deployable communications systems will not be easy; otherwise the problem would have been solved by now. But from a systems standpoint, it appears that many of the problems are more organizational in nature than technical. Fundamentally, this means that the physical system can only be as integrated as the management and organizational infrastructure behind it. Where concepts are not well understood or executed in organizations, it will be difficult to design these concepts into a physical system; the finished product will mirror the strengths and weaknesses of its design. While solving the small problems is important, the task still remains to ensure that all the solutions are integrated and that the total product produces the desired system performance.

In the goal architectures, the Air Force has asked *deployable communications* systems to perform things which have not yet been solved for the fixed systems--compatible data formats, for example. If the organizational and management issues behind data formats remain unresolved, the best of equipment will not solve the problem. Simply providing a personal computer to Oscar Madison (of the "Odd Couple") will not, in itself, make him an organized person.

If this thesis can leave the reader with a better appreciation for the underlying causes of persistent integration problems with *deployable communications* then its goal has been reached. Possibly the single most important concept could be that the way systems are fielded is just as critical as the system itself. Study after study can determine

where technical problems lie and recommend solutions, but without a coherent mechanism to implement to solutions, the best plans will never be fully realized.

D. SUMMARY

The technical problems facing deployable communications systems today are fairly well characterized and understood. The solutions lie in developing interfaces to allow existing equipment to interoperate, while at the same time reaching toward a goal of greater use of common standards, open systems, modular equipment, and distributed processing. But if the goal of integrated systems is to be reached, the management structure which spawns the system must itself become integrated. This author is optimistic that both goals can be reached.

APPENDIX

THEATER BATTLE MANAGEMENT GENERAL OFFICER STEERING GROUP/WORKING GROUP CHARTER

1. **PURPOSE:** This Charter defines the membership of the Theater Battle Management (TBM) General Officer Steering Group (GOSG) and its subordinate TBM Working Group (WG).

2. **SCOPE:** Theater Battle Management is broadly defined as that function of AF command, control, communications, and intelligence (C³I) which supports the rapid acquisition and reliable processing, correlation, and dissemination of information required for decision making in support of theater operations at all levels from command battle management to the mission planning and execution levels. TBM is focused on automation of processes, integration of systems, and interoperability of hardware, software, and procedures which directly or indirectly affect the speed and efficiency of tactical and strategic force execution. The program will orchestrate the fielding of selected C³I projects through rapid prototyping, evolutionary acquisition, and continuous user-developer interaction. The TBM C³I goal is to improve our warfighting ability through (1) accelerating information flow to the commanders, (2) providing more timely information for decisions, (3) providing better decision support, and (4) decreasing the tasking-to-execution-to-retasking cycle times.

3. **ORGANIZATION:** The GOSG is supported by the TBM WG, which provides a forum for: (1) working issues assigned by the GOSG, (2) developing recommendations for inclusion of selected efforts within the TBM program, (3) providing activity reports to each GOSG meeting, and (4) exchanging information. Neither the GOSG nor the WG is intended to supplant existing staff organizations/groups dedicated to resolving TBM problems, but rather to provide cross functional guidance and policy.

a. GOSG membership is comprised of AF customers (TAC/DO, PACAF/DO, MAC/XO, AFSOC/CV, AFIC/CV, and AFSPACECOM/DO), requirements developers (TAC/DR, MAC/XR, SAC/XR), and suppliers (AFSC/XR, AFCC/CC, ESD/CV, and SSC/CC). The chairman is TAC/DR. Other agencies are asked to participate and provide expertise in areas of interest to the AF and include representatives from the MAJCOM/IN/SC/XP, SAF/AQP, AF/XO/IN/SC, and the suppliers/laboratories such as ASD, ESD, Rome and Armstrong Labs, and the TIC. The Secretariat is TAC/DRI.

TAC/SCP serves as technical advisor to the Secretariat. Responsibilities for day-to-day decision making will be delegated to the TBM WG.

b. The General Officer Steering Group will:

(1) Serve as the governing body to set policy for the theater operators on procedures, terminology, direction and scope of TBM activities and establish priorities for requirements.

(2) Provide direction, guidance, and support for TBM initiatives and C³I automation efforts.

(3) Establish focal points for resolution of problems/issues regarding TBM systems' requirements, funding, development, fielding, and the connectivity between other systems.

(4) Serve as the sponsoring group for the TBM WG.

(5) Confirm decisions of the TBM WG.

(6) Meet twice a year (or as required).

c. Associate (ex officio) membership will be extended to the Army, Navy, and Marines. Their participation will be as observers/advisors as required.

d. The TBM Working Group membership is comprised of customer representatives from appropriate TAC, PACAF, USAFE, MAC, SAC, AFSOC, AFIC, and AFSPACECOM program offices (both functional and technical), interested air staff (SAF/AQP/ACT, AF/XOO/XOR/INX/SCM), suppliers (AFSC, AFCC, AFCSC, ASD, AWS, DMA, ESD, SSC, Rome and Armstrong Labs), and joint services (equivalent user/developer-level representation). As with the GOSG, TAC/DRI is the Secretariat. The group may establish one or more subgroups tailored to address specific programs/issues assigned.

e. The Working Group will:

(1) Work issues assigned by the GOSG.

(2) Review, prioritize, and approve TBM needs.

(3) Monitor TBM programs under development.

(4) **Oversee TBM laboratory/testbed developments.**

(5) **Review advanced TBM technology and command-unique TBM programs for AF applicability and recommend candidates for rapid prototyping considerations.**

(6) **Define specific TBM interoperability issues and propose solutions.**

(7) **Confirm decisions of subordinate working groups.**

(8) **Meet as required.**

LIST OF ACRONYMS

ABCCC	Airborne Command and Control Center
ACC	Air Component Commander
AF	Air Force
A-FAC	Airborne Forward Air Controller
AFCC	Air Force Communications Command
AFCC/COMAFFOR	Air Force Component Commander/Commander Air Force Forces
AFCH	Air Force Component Headquarters
AFCS	Air Force Cryptologic Security Center
AFIC	Air Force Intelligence Command
AFSC	Air Force Systems Command
AFSOC	Air Force Special Operations Command
AFSPACECOM	Air Force Space Command
ASD	Aeronautical Systems Division
ASOC	Air Support Operations Center
ATO	Air Tasking Order
AWACS	Airborne Warning and Control System
AWS	Air Weather Service
C ²	Command and Control
C ³	Command, Control, and Communications
C ⁴ I	Command, Control, Communications, Computers and Intelligence
CAFMS	Computer Assisted Force Management System
CALOW	Crisis and Limited Objective Warfare
C-CS	Communications-Computer System
CINC	Commander-in-Chief
CONUS	Continental United States
CRC	Control and Reporting Center
CRP	Control and Reporting Post
CSAF	Chief of Staff of the Air Force
CTAPS	Contingency TACS Automated Planning System
CVSD	Continuously Variable Sloped Delta
DCS	Defense Communications System
DCSA	Deployable Communications-Computer Systems Architecture
DGM	Digital Group Multiplexing equipment
DISA	Defense Information Systems Agency
DMA	Defense Mapping Agency
DoD	Department of Defense

ESD	Electronic Systems Division
FACP	Forward Air Control Post
FACRP	Functional Analysis and Consolidation Review Panel
FLOT	Forward Line of Troops
GOSG	General Officer Steering Group
GMFSC	Ground Mobile Forces Satellite Communications
ITN	Information Transfer Node
JCS	Joint Chiefs of Staff
JITC	Joint Interoperability Test Center
Joint STARS	Joint Surveillance Targeting Attack Radar System
KBPS	Kilobits per second
MAC	Military Airlift Command
MAJCOM	Major Command
MBPS	Megabits per second
MCE	Modular Control Element
MOB	Main Operating Base
MPC	Message Processing Center
MTACC	Modular Tactical Air Control Center
MTI	Moving Target Indicator
NCA	National Command Authorities
NTB	National Test Bed
OSD	Office of the Secretary of Defense
PACAF	Pacific Air Forces
PCM	Pulse Code Modulation
SAC	Strategic Air Command
SAF	Secretary of the Air Force
SATCOM	Satellite Communications
SHF	Super High Frequency
SSC	Standard Systems Center
TAB	Tactical Air Base
TAC	Tactical Air Command
TACC	Tactical Air Control Center

TACS	Tactical Air Control System
TACP	Tactical Air Control Party
TADIL	Tactical Data Link
TBM	Theater Battle Management
TC ² -21	21st Century Tactical Command and Control
TIC	Technology Integration Center
TPFDL	Time Phased Force Deployment List
TRI-TAC	Joint Tactical Communications
USAF	United States Air Force
USAFE	United States Air Forces Europe
USAFTC	United States Air Force Tactical Communications
WOC	Wing Operations Center

LIST OF REFERENCES

1. Wright, R., *Systems Thinking: A Guide to Managing in a Changing Environment*, Society of Manufacturing Engineers, 1989.
2. Science Applications International Corporation, *21st Century Tactical Command and Control Study [TC²-21], Volume 1: Proposed Architectural Framework*, 30 August 1985.
3. Air Force Studies Board, *Decision Aiding Technology for Tactical Battle Management*, December 1990.
4. Air Force Studies Board, *U.S. Air Force Tactical Communications*, December 1991.
5. *Command, Control, Communications and Computers (and Intelligence) for the Warrior*, Joint Staff/J-6 Concept Paper, Undated (Approximately February 1992).
6. Telephone conversation between Mr. Cristy, JIEO-TDAA, Fort Monmouth, NJ, and the author, 28 May 1992.
7. Air Force Pamphlet 700-50, Vol. I, *Air Force Communications-Computer Systems Architecture*, July 1990.
8. Air Force Pamphlet 700-50, Vol. II, *Deployable Communications-Computer Systems Architecture (DCSA)*, Initial Draft, March 1992.
9. Buchanan, H., *The Tactical Air Control System: Its Evolution and Its Need for Battle Managers*, Air University Press, May 1987.
10. *Concept of Operations - Modular Tactical Air Control Center*, HQ TAC/DOY, Langley AFB, VA, June 1990.
11. *JTC3A Handbook 8000, Joint Connectivity Handbook*, Joint Tactical Command, Control, and Communications Agency, Fort Monmouth, NJ, April 1989, 2nd edition.
12. *Brief of the Tactical Air Control System*, HQ TAC/DOY, Langley AFB, VA, May 1990.
13. "Gulf's Electronic Marvels Set for Multiple Upgrades", *Signal*, August 1991, p. 53 to 55, no author listed.

14. Telephone conversation between Maj. Hinchman, HQ USAF/SCMT, Washington, D.C., and the author, 21 April 1992.
15. *Brief of the AF C4 Architecture*, HQ USAF/SCX, Washington D.C., September 1991.
16. Scalet, E. J., *Interoperability Between the Defense Communications System (DCS) and the Joint Tactical Communications (TRI-TAC) System*, Air War College Research Report, May 1985.
17. Telephone conversation between Dr. Starr, MITRE Corporation, McLean, VA, and the author, 15 Apr 92.
18. Telephone conversation between Mr. Dube, MITRE Corporation, Fort Huachuca, AZ, and the author, 15 Apr 92.
19. McKenzie, D., "U. S. Air Force Communications in Desert Storm," *IEEE Communications Magazine*, January 1992.
20. Starr telephone interview, 17 Jan 92.
21. Joint Publication 1-02, Department of Defense Dictionary of Military and Associated Terms, 1 December 1989.
22. Stares, P. B., *Command Performance: The Neglected Dimension of European Security*, The Brookings Institution, 1991.
23. Orr, G., *Combat Operations C³I: Fundamentals and Interactions*, Air University Press, July 1983.
24. Hughes, W. P., *Fleet Tactics*, Naval Institute Press, 1986.
25. Joint Publication 1, Joint Warfare of the US Armed Forces, 11 November 1991.
26. Copernicus Project Office, *Copernicus Phase I Requirements Definition*, August 1991.
27. *C2 Functional Analysis and Consolidation Review Panel (FACRP) Report*, Joint Chiefs of Staff Study, 30 October 1991.
28. Telephone conversation between Lt. Col. Sullivan, HQ USAF/SCMT, Washington D.C., and the author, 30 September 1991.

29. "Tailored Communications Meet Fighter Wing Moves," *Signal*, August 1991, p. 57-59, (no author listed).
30. Stallings, W., *ISDN: An Introduction*, Macmillan Publishing Company, 1989.
31. Fleming, S., Get Ready for T-3 Networking, *Data Communications*, September 1989.
32. McKenzie, D., "Tactical C³I Architecture in Support of Global Reach, Global Power," Post-Desert Storm staff position paper prepared for Headquarters, 9th Air Force, Shaw Air Force Base, SC, 3 October 1991.
33. Joint Staff/J-6A Unclassified Memorandum to Assistant Secretary of Defense (Command, Control, Communications and Intelligence), Subject: Policy Direction for C³ Architectures, 15 May 1991.
34. Munro, N., "Pentagon Presses C³I Effort," *Defense News*, p. 1 and p. 82, 24 February 1992.
35. Telephone conversation between Mr. Entlich, Air Force Studies Board (National Research Council), Washington, D.C., and the author, 18 February 1992.
36. Telephone conversation between Lt. Col. Davis, HQ AFSC/XTR, Andrews AFB, MD, and the author, 19 February 1992.
37. E-Systems Report 1005/86, *Tactical Air Control System Functional Distribution Options*, 30 September 1986.
38. Balderman, M., C3 Architecture Review (Joint Staff/J-6 information paper), 6 May 1991.

BIBLIOGRAPHY

Bethmann, R. C., and Malloy, K. A., *Command and Control: An Introduction*, Master's Thesis, Naval Postgraduate School, Monterey, CA, March 1989.

C³I Architectural Study for Theater Battle Management (Draft), Electronic Systems Division, Hanscom AFB, MA, Undated.

Communications Support for the Air Force Battlefield Environment 1993-1999, Technology Integration Center, Scott AFB, IL, 15 Nov 1991.

Daft, R. L., *Organizational Theory and Design*, 3rd ed., West Publishing Co., 1989.

Department of the Air Force Report, *Reaching Globally, Reaching Powerfully: The United States Air Force in the Gulf War*, September 1991.

Department of the Air Force, *The Air Force and U. S. National Security: Global Reach - Global Power*, June 1990.

Dearborn, R., and Morales, R., *An Overview of the Copernicus C4I Architecture*, Master's Thesis, Naval Postgraduate School, Monterey, CA, March 1992.

Endoso, J., "Navy's Copernicus Repaves the Information Highway," *Government Computing News*, 20 January 1992.

Office of the Assistant Secretary of Defense Unclassified Letter to Mr. Duane Andrews- (ASD for C⁴I), Subject: Implications of the Command and Control Functional Analysis and Consolidation Review Panel Report of 30 October 1991, 28 December 1991.

Stallings, W., *Data and Computer Communications*, 3rd ed., Macmillan Publishing Company, 1991.

Tuttle, J. O., "C⁴I for the 21st Century," *IEEE Communications Magazine*, January 1992.

INITIAL DISTRIBUTION LIST

1. Defense Technical Information Center 2
Cameron Station
Alexandria, VA 22304-6145
2. Library, Code 52 2
Naval Postgraduate School
Monterey, CA 93943-5002
3. HQ USAF/SCMT 1
The Pentagon
Washington, D.C. 20330-5190
4. HQ TAC/DRCG 1
Langley AFB, VA 23665
5. HQ TAC/DRIV 1
Langley AFB, VA 23665
6. HQ 9AF/SCX (Capt McKenzie) 1
Shaw AFB, SC 29152-5000
7. TIC/TIAA (Mr. Holt) 1
Scott AFB, IL 62225
8. MITRE Corporation/Mailstop Z-521 1
7525 Colshire Drive
McLean, VA 22102
9. National Academy of Sciences 1
2102 Constitution Avenue, N.W.
Room HA-254
Air Force Studies Board (Mr. Entlich)
Washington, D.C. 20418
10. Carl R. Jones, Code AS/JS 1
Naval Postgraduate School
Monterey, CA 93943-5002

- | | | |
|-----|----------------------------------------------------------------------------------------|---|
| 11. | Dan C. Boger, Code AS/BO
Naval Postgraduate School
Monterey, CA 93943-5002 | 1 |
| 12. | Capt Michael A. Cervi, Code 39
Naval Postgraduate School
Monterey, CA 93943-5002 | 2 |