

2

NPS-AS-92-019

# NAVAL POSTGRADUATE SCHOOL

Monterey, California

AD-A255 893



DTIC  
ELECTE  
OCT 6 1992  
S C D

92-26436  
5115



**Some Notes on the Application of  
Single Minute Exchange of  
Die (SMED)**

by

**Dan Trietsch**

**July 1992**

92 16 1992

Approved for public release; distribution is unlimited.

Prepared for: Naval Sea Systems Command  
Washington, D.C. 20362

NAVAL POSTGRADUATE SCHOOL  
Monterey, California

RADM. R. W. West, Jr.  
Superintendent

Harrison Shull  
Provost

This report was prepared for and funded by the Naval Sea Systems Command, Washington, D.C.

Reproduction of all or part of this report is authorized.

This report was prepared by:

Dan Trietsch  
Dan Trietsch  
Department of Administrative Sciences

Reviewed by:

David R. Whipple for  
David R. Whipple, Chairman  
Department of Administrative Sciences

Released by:

Paul J. Marto  
Paul J. Marto, Dean of Research

# REPORT DOCUMENTATION PAGE

*Form Approved*  
*OMB No. 0704-0188*

Public reporting burden for this collection of information is estimated to average 1 hour per response, including the time for reviewing instructions, searching existing data sources, gathering and maintaining the data needed, and completing and reviewing the collection of information. Send comments regarding this burden estimate or any other aspect of this collection of information, including suggestions for reducing this burden, to Washington Headquarters Services, Directorate for Information Operations and Reports, 1215 Jefferson Davis Highway, Suite 1204, Arlington, VA 22202-4302, and to the Office of Management Budget, Paper Reduction Project (0704-0188), Washington, DC 20503.

1. AGENCY USE ONLY <i>(Leave Blank)</i>	2. REPORT DATE 27 August 1992	3. REPORT TYPE AND DATES COVERED Technical Report, July 1992
---	----------------------------------	---

4. TITLE AND SUBTITLE Some Notes on the Application of Single Minute Exchange of Die (SMED)	5. FUNDING NUMBERS  N0002492WR01521
--	---

6. AUTHOR(S)  Dan Trietsch	
----------------------------------	--

7. PERFORMING ORGANIZATION NAME(S) AND ADDRESS(ES)  Administrative Sciences Department Naval Postgraduate School, Monterey, CA 92943	8. PERFORMING ORGANIZATION REPORT NUMBER  NPS-AS-92-019
---	---

9. SPONSORING / MONITORING AGENCY NAME(S) AND ADDRESS(ES)  Naval Sea Systems Command , Washington, D.C. 20362	10. SPONSORING/MONITORING AGENCY REPORT NUMBER
---	--

11. SUPPLEMENTARY NOTES

12a. DISTRIBUTION / AVAILABILITY STATEMENT  Approved for public release; Distribution Unlimited	12b. DISTRIBUTION CODE
---	------------------------

13. ABSTRACT *(Maximum 200 words)*

SMED is a method introduced by Shigeo Shingo to reduce setup durations from hours to minutes. The name implies a goal of reducing each setup to less than 10 minutes, so the number of minutes will be expressed by a single digit. SMED has been primarily developed for repetitive manufacturing, and is most beneficial when dealing with recurring setups. In this paper we present the basic theory of SMED and discuss to what extent it is applicable to custom job shops and repair job shops, such as machine shops at naval shipyards. We also present general rules how to prioritize SMED efforts, i.e., which resources should be treated first. This is important, because as we approach the goal of a single digit setup, it may be required to invest progressively more to obtain further savings.

14. SUBJECT TERMS	15. NUMBER OF PAGES 51
	16. PRICE CODE

17. SECURITY CLASSIFICATION OF REPORT Unclassified	18. SECURITY CLASSIFICATION OF THIS PAGE Unclassified	19. SECURITY CLASSIFICATION OF ABSTRACT Unclassified	20. LIMITATION OF ABSTRACT Unlimited
---	--	---	---

**Some Notes on the Application of  
Single Minute Exchange of Die (SMED)**

by

Dan Trietsch\*

July 1992

Accession For	
NTIS GRA&I	<input checked="" type="checkbox"/>
DTIC TAB	<input type="checkbox"/>
Unannounced	<input type="checkbox"/>
Justification	
By	
Distribution/	
Availability Codes	
Dist	Special and/or Special
A-1	

DTIC QUALITY INSPECTED 1

---

\* Code AS/Tr, Department of Administrative Sciences, Naval Postgraduate School, Monterey, CA 93943

This work was supported by the NPS Foundation Research Program and by NAVSEA Systems Command.

**Some Notes on the Application of  
Single Minute Exchange of Die (SMED)**

*Abstract*

**SMED is a method introduced by Shigeo Shingo to reduce setup durations from hours to minutes. The name implies a goal of reducing each setup to less than 10 minutes, so the number of minutes will be expressed by a single digit. SMED has been primarily developed for repetitive manufacturing, and is most beneficial when dealing with recurring setups. In this paper we present the basic theory of SMED and discuss to what extent it is applicable to custom job shops and repair job shops, such as machine shops at naval shipyards. We also present general rules how to prioritize SMED efforts, i.e., which resources should be treated first. This is important, because as we approach the goal of a single digit setup, it may be required to invest progressively more to obtain further savings.**

## **Introduction**

One definition of quality is adding as much value as possible for the customer while preventing waste. Waste can be defined as any activity or input that does not add value to the customer.

Obvious examples of waste, in line with the traditional view of quality, are scrap and rework. While producing scrap, no value is added to the customer. On the contrary, raw materials, labor, machine time, tools and energy are wasted. Rework does produce value to the customer, hopefully, but it represents waste which preceded it, and it usually requires more inputs than doing it right in the first place,<sup>1</sup> i.e., more waste; the net effect is that all the inputs invested in rework represent waste. Below we concentrate on less obvious types of waste.

In general, some activities contribute value to the customer directly, and are thus productive. Other activities produce obvious waste (e.g., defective items), and are thus counterproductive. Some activities, often referred to as indirect activities, do not produce value, but support activities that do. For example, product storage, transportation to and from resources, and inspections belong to this group, and so do setups.

Traditionally, indirect activities were often considered productive, since they serve value adding activities. Nevertheless, they do not produce value in and as of themselves, and thus they must be considered waste (i.e., a quality problem). In particular, setup or changeover time between jobs is also waste (non-value-adding).

---

<sup>1</sup>This observation should not be construed as an exhortation to "do it right the first time." Rather it says that doing it right the first time is a goal to strive for.

Calling such indirect activities waste should not be construed to mean that people involved in carrying them out are not productive. Rather, it means that a system that includes such activities needs improvement in terms of reducing them. Note that this implies that practically every system needs improvement--a basic tenet under TQM. Also note that this puts the responsibility squarely where it belongs, i.e., in management's domain.

For our purpose here, following Shingo, we define setup time as the time elapsed from the moment a machine finishes one job, until it starts working again *producing quality items* for the next job.<sup>2</sup> An implicit assumption in this definition is that the machine is not scheduled to idle between jobs. If it is, we would start measuring the setup from the instant setup activities on the machine start. More importantly, preparation time for the setup that is done while the machine is working, is not part of the setup time according to our definition here.<sup>3</sup>

In light of the above, reducing setup time increases the quality of operation by definition. Consider that setups often produce scrap as a by-product, and this argument becomes even stronger. Indeed it is often possible to reduce the amount of scrap produced

---

<sup>2</sup>This includes tearing down the former job, which is why some people prefer the terminology changeover time. We shall use the two terms interchangeably, however.

<sup>3</sup>This omission is appropriate when the machine involved is a bottleneck, i.e., a resource that limits throughput and thus limits the value we can add to our customers. For a bottleneck resource, when we minimize the time it is not producing quality products, we increase our throughput. Note, also, that a bottleneck should never be scheduled to idle between jobs (except for preventive maintenance, which can be viewed as a special type of job itself), to avoid unnecessary loss of throughput; so, measuring the setup from the end of the former job to the beginning of the next one makes perfect sense. Nevertheless, applying setup reduction methods to non-bottleneck resources also provides important benefits to the system, especially in terms of flexibility.

during setup as a direct result of the setup reduction. For instance, scrap is often produced while adjusting equipment; so, by eliminating the need for adjustments we not only save the time they took (typically 50% of the setup time), but also eliminate this scrap.

After WWII, the Japanese have embarked on a national movement to improve quality (i.e., combat waste). Since the early seventies, as part of this movement, they tackled setup reductions. At the heart of the setup reduction effort is a method called SMED (Single Minute Exchange of Die). Though the name implies a limitation to presses, for which the method was originally developed, SMED can be applied to setups other than die changes. The successes achieved in applying SMED are sometimes referred to as a revolution, so profound were their effects. For instance, JIT (Just-in-Time), the famous Japanese management system, could not have been developed without SMED. Such a success, in general and particularly in the setup reduction crusade, merits imitation.

SMED applications, in addition to their beneficial effect on scrap, often prevent the need for new equipment. Instead, the existing equipment is augmented and adapted. This often takes the form of converting a general purpose machine that can be adjusted infinitely, wasting time in the process, to a dedicated machine that can be set up fast for some group of parts for which it is pre-adjusted. Thus the use of SMED is in synergy with the application of Group Technology (where we sort our jobs to small families and create cells to handle each of them).

Before, setup time was regarded almost as a given: a necessary evil that may be improved a bit at large cost perhaps, but not really avoidable. Production management was more concerned with planning around long setups than with reducing them by orders of



magnitude so that they will no longer pose a problem. The EOQ model is perhaps the best known example of managing around setup time, which is sometimes referred to as the order cost in this context. The EOQ model minimizes some of the waste caused by setups without trying to improve the setups at all.

The SMED revolution started in 1969, when Toyota learned that press die changes that were taking 4 hours at Toyota City, Japan, were taking 2 hours at Wolfsburg, Germany (where Volkswagens are made). The evidence that their setup times were excessive was the impetus management needed to realize that they have neglected an important opportunity. They asked Shigeo Shingo, a very experienced industrial engineering consultant, to reduce their setup to less than 2 hours. After several months of work with a team of press operators, Shingo succeeded in reducing the setups to 1.5 hours. This was done mainly by identifying activities that could be done in parallel to the press working, and taking care not to have the press wait idly for any of them. The 1.5 hours were spent actually removing the old die from the press and attaching the new one on, including adjustments. These activities could not have been done while the press was working.

A reduction from 4 hours to 1.5 hours may look like a very impressive achievement, and it was at the time, but it's not a reduction by orders of magnitude. Indeed, Shingo has been achieving similar successes by the same method since the early fifties, so no breakthrough was involved . . . yet. To illustrate the magnitude of such an improvement, using the EOQ logic, and assuming the setup cost is proportional to the time it takes (an assumption that is approximately correct when nonproductive machine time is the dominant cost involved), reducing the setup to 37.5% of what it was (as was the case here),

corresponds to reducing lot sizes to about 61% (the square root of 0.375), with an identical reduction in the total inventory carrying and ordering costs. This is good, but not revolutionary. The point is that due to the EOQ's square root formula, to reduce the inventory costs and the lot sizes by, say, tenfold, we have to reduce the setup cost by a hundredfold (i.e., ten squared).

The revolutionary step came next, when Toyota, now free of the blinders that hid the importance of setup reductions, asked Shingo for a further reduction to 3 minutes. Such a reduction would make a qualitative difference indeed!

Shingo was too polite to say right away that it was impossible, so he decided to bide his time and refuse politely later. By the time he would have been ready to say "Sorry, it can't be done," however, an inspiration came to him that made the goal attainable.<sup>4</sup> It involved a relatively modest investment in hardware, which would make possible preparing the next setup outside the press, in parallel to its operation. The new goal was achieved in three months.

The success of this bold move made it possible for Toyota to disregard the EOQ model, and specify very small lots indeed (i.e., even smaller than the 11% EOQ would call for after such a reduction). The reason Toyota could ignore the EOQ model at this stage was that the inventory costs involved became too small to be the driving consideration.

---

<sup>4</sup>This anecdote is based on the author's recollection of Shingo's description of the event in a former edition of his book (Shingo 1985). The current edition already has a different story, according to which the new inspiration came to Shingo as soon as he heard the new request. Whether this author's recollection of the alleged former version is correct or not, one thing is clear: management created this breakthrough by what seemed at the time an outrageous demand. So, Shingo deserves the credit for the idea, and Toyota deserves the credit for making it happen.

Other considerations, which have always been dominated by the inventory costs, such as flexibility and lead-time, now became the drivers for the lot size determination. This is the seminal development that made possible Toyota's revolution in production scheduling: Just-In-Time (JIT).

Let us elaborate this point a bit. Using EOQ, a reduction to  $3/240 = 1.25\%$  implies a reduction to 11% in lot size and inventory costs, and an increased setup frequency of about nine. In total the more frequent but shorter setups would take 11% of the time setups took before. This implies a savings of 89% of the former total setup time. Thus there is much additional machine capacity, *so the machine may no longer be a bottleneck*. One can increase the number of setups by a factor of 80 approximately--and decrease lot sizes, likewise, by a factor of 80--and still have the same capacity as before. Assuming that after the reduction there exists excess capacity, the marginal value of machine time is *zero*, which implies that the order cost in the EOQ model should be reduced, or even eliminated. Thus, as long as enough labor exists to perform the setups, one can often schedule more setups than EOQ calls for, and reduce the lots by more than EOQ calls for. In fact, at Toyota the limitation is how many setups the workers can prepare while the machines are running. That is, the lot size becomes just large enough to keep the machine busy while the new setup is being prepared in parallel.

Following this first success, Shingo created the concept of SMED. The acronym stands for "single minute exchange of die," but was really meant as "single *digit* exchange of die." That is, die changes that require a single-digit number of minutes to perform. For instance, 9 minutes is acceptable, but not 10. As mentioned above, the method applies to any setup,

not just ones that involve die changes.

Shingo has shown that even setups that formerly took days can be done in a few minutes. This makes possible proportional lead-time reductions (long lead-times are an obvious quality problem). The more a setup is reduced, however, the more we may have to invest to achieve further reductions, so for some setups the goal may not be reached. Nevertheless, although not every setup operation can be reduced to single-digit minutes, practically all setups can be reduced significantly. Furthermore, there is no justification to stop looking for reductions once the goal has been reached. The next evolutionary objective, already achieved for many setups (especially in Japan), is One Touch Change of Die (OTCD), which calls for instantaneous setups.

Though SMED was developed for the repetitive manufacturing environment, where the exact same setups are repeated periodically, much of the methodology can be applied to other environments, e.g., job shops. One way to do it is to look for setups that do repeat. Other ways, which are applicable even to unique setups that never repeat, will be discussed below. Furthermore, the methodology can, and should, be applied even outside the manufacturing environment or the repair environment. We illustrate by some relatively minor examples that also show how SMED is often applied.

- Saving time in adjusting viewgraphs. This is done by marking the correct location and adjustment once and for all [Johansen & McGuire, 1986]. The savings may be not more than a minute each time, but taken over dozens of uses, we soon realize savings of hours. Consider the frequency at which viewgraphs are adjusted while the audience is waiting, and the number of hours we talk about becomes even more meaningful. (Of course, doing the job right implies that the viewgraph will be ready before the lecture is scheduled to start, i.e., it is an activity that can be done ahead of time.)
- An application of the same principle to a similar frequent adjustment was given to me

by a student who applied SMED in his personal life with zeal. It concerns getting the shower to the required temperature (part of the morning setup). My student simply marked the optimal tap position, so he did not have to repeat the same adjustment daily. The new setup involved opening the tap at the hot setting until the hot water arrived, and then adjusting instantly to the marked position. The savings include time, water, energy, and the likelihood to get scorched or chilled. The latter are analogous to scrap, and, as mentioned above, SMED often reduces scrap while saving time.

- The same student stopped untying his ties all the way, so there would be no need to tie them again. This gave him significant savings in getting set up for work each morning. Note that this solution allowed him to adjust the length of his ties right, once and for all. So this application includes avoiding an adjustment. (I've been doing the same thing myself for years, simply because I was lazy, but my student showed me I was really practicing SMED all the time.)
- Returning to the shower example for a while, by an investment in hardware, even more savings of water and energy can be achieved. This is done by circulating hot water in the system for a while before allowing the water to flow. The necessary hardware consists of return pipes and pumps in the network, as found aboard many ships and in some high-rising buildings. When using such a system one would circulate the water in parallel to other preparations.<sup>5</sup>

As we have seen, we can look for setup reduction opportunities on any resource, and not just machines. Following are examples of opportunities relating to the service sector (military and otherwise):

- minimizing the time it takes to dock a ship (during which both the pier and the ship are not productive);
- minimizing the time required to prepare a ship for deployment;

---

<sup>5</sup>Valves exist in the market that adjust the water temperature automatically. They perform the same function as that achieved by the first method. Most traditional engineers would suggest one of these automatic valves as the solution to the problem right away, without stopping to consider whether this level of sophistication is actually required. The new golden rule of automation is: streamline first, then (if still necessary) automate.

- **minimizing the time to prepare an aircraft for takeoff;**
- **minimizing the time to unload and load a truck;**
- **minimizing the time it takes to provide instructions and other necessary input to workers (so they can start the next job earlier, and be more likely to do it right);**

**In general, identifying areas in which SMED techniques can be useful is a challenge in which everyone should be involved. To be able to do that, however, it is important to review SMED as developed by Shingo [Shingo, 1985]. We do this in the next section, which includes some minor interpretations that are different from the original, but is essentially a summary of Shingo's book. Then, we discuss some specific opportunities that exist in job shops, such as Shop 31 at the naval shipyards. Finally, we discuss how to prioritize SMED efforts.**

### **SMED: A Brief Description**

**Shigeo Shingo developed SMED for the repetitive manufacturing environment, where production is in lots. There, the advantage of SMED is that it makes possible smaller lots (e.g., lots with less than 500 units, in contrast to more than 10000).**

**Shingo defines setup time as the time elapsed from the moment the machine finishes the last item in one lot, until it starts the first good item in the next lot, and is ready to continue without further adjustments. The time to set up each unit, if any, is not part of the setup according to this definition. A possible reason for this is that for presses and many other mass production machines the time to switch from one unit to the next, in the same lot, is often negligible. Changing over from one lot to another, however, is often very time-**

consuming. In machine job shops, however, it often takes a long time to set up each unit even if it is part of a lot.

Fortunately, the same principles that make possible fast changeovers from one lot to another, often make it possible to switch products within the same lot faster. Therefore, we need not make a conceptual distinction between setting up a machine for a new type of part (Shingo's setup definition) and changing a part on the machine in the middle of a lot. Of course, these two are different from each other in the details, so they are not *identical* setups. In conclusion, the time the machine is idle while changing over from one part to the next will be the setup we're concerned with, whether the parts belong to the same lot, or not.

### **The Conceptual Stages of SMED**

Shingo identifies four stages in SMED application:

0. Preliminary Stage: Internal and External Setups are Mixed.
1. First Stage: Separate Internal and External Setups.
2. Second Stage: Convert Internal Setup to External Setup.
3. Third Stage: Streamline Both Internal and External Setups.

We now discuss these four stages in more detail, and later discuss some ways of achieving them.

0. Preliminary Stage: Internal and External Setups are Mixed.

SMED differentiates between internal setup and external setup. *Internal setup* consists

of setup operations that can only be done while the machine is stopped. Such operations may include mounting or removing dies and fixtures. *External setup* includes setup operations that can be done while the machine is running. Operations like transporting dies and fixtures to and from the machine and ensuring the correct tools and parts are on hand and functioning before changeover are all examples of external setups. During the preliminary stage no effort is invested in differentiating external and internal setup, so external setup is often performed while the machine is stopped.

#### **1. First Stage: Separate Internal and External Setups.**

Recall that we defined setup time starting when the last good product is completed by a resource and ending when the first good product is produced consistently, without further adjustments. It becomes clear now that setup time *cannot be less* than the internal setup, *and should not be more* than the internal setup. Therefore, care should be taken to perform all external setup while the machine is running (either before or after the changeover). For example, transporting the new die to the press should be done before the changeover begins, and transporting the old die to storage should be done after the changeover. These two activities are both external setups. If the operator cannot do these jobs while the machine is running, it may be justified to assign another person to do it.

Typically, the first stage requires very small investments in hardware, if at all. Instead, as any other improvement effort, it requires thoughtware, i.e., brain power.<sup>6</sup> The benefit,

---

<sup>6</sup>Fortunately, brainpower, though precious, is a potentially ubiquitous commodity. It just needs to be unleashed, and under TQM and modern management in general there is a good chance this will happen. In fact, it has already started to happen.



again typically, is a savings of about 50% of the setup time.

## **2. Second Stage: Convert Internal Setup to External Setup.**

Once no external setups are performed while the machine is waiting, a good way to reduce the setup further is to analyze the internal setup carefully and see which activities can be transformed to external setup. For example, Shingo cites a case where by using an extra table for a planer the new job could be set up while the old one was running with the other table on the machine. Then, the tables were exchanged in internal setup. This may require a small investment in hardware (an extra table and a crane), but it can alleviate the need for an extra planer. Other examples: preheat a die that was usually heated as part of internal setup; store vacuum in a large tank and impart it to a setup by opening a valve.

## **3. Third Stage: Streamline Both Internal and External Setups.**

So far, all we've done was to shift work from the time the machine is down to time when the machine is running. We did this by separating internal and external setups, and by transforming internal setups to external setups. Nevertheless, though the setup itself may be cut significantly, the total amount of work may not be reduced. Thus, if we intend to increase the number of setups, we may find that we don't have enough manpower to perform the external setups. Viewed from another point, lots have to be at least large enough to last while the external setups are performed. At the third stage we reduce the total setup effort by streamlining all setup activities, both internal and external. Examples: avoiding the need for adjustments by providing stops that locate the new die exactly at the

right spot; using dies with standardized external dimensions that avoid the need to adjust the stroke of the press; using one-turn fasteners, instead of traditional nuts and bolts, which require many turns; using rollers and pushing the old die out by inserting the new die in.

Shingo cites mechanization as a fourth stage, but says that it is very rarely justified. According to Shingo, one can typically reduce setups from up to 24 hours down to three or four minutes *without* any mechanization. Then, mechanization can gain another minute or two, and reduce the setup to the range of one to three minutes. But, the investment is not likely to be justified when viewed this way. Usually, however, we cite the whole reduction from hours to minutes as the justification for mechanization, and this is simply not correct. To get a fair comparison, one should compare the best solution available with and without mechanization. Furthermore, when one starts a mechanization project without streamlining the old process first, one is not likely to achieve the best results with mechanization either. In such cases it's likely that mechanization will take the setup down to a level *higher* than could have been achieved without it. This is known as "paving the cowpath," and has been the downfall of many mechanization and computerization projects.

Note that the second and third stage can actually be done in parallel. That is, it is not necessary to transform internal setup to external setup *before* streamlining some setup activities. Nevertheless, the conceptual order implied by the stages as presented above is good. First, shift as much work to times when the machine is running (stages 1 and 2), then, when we have a more rational process, we can concentrate on detailed small improvements. Figure 1 summarizes the stages of SMED. We now discuss some details associated with the various stages.

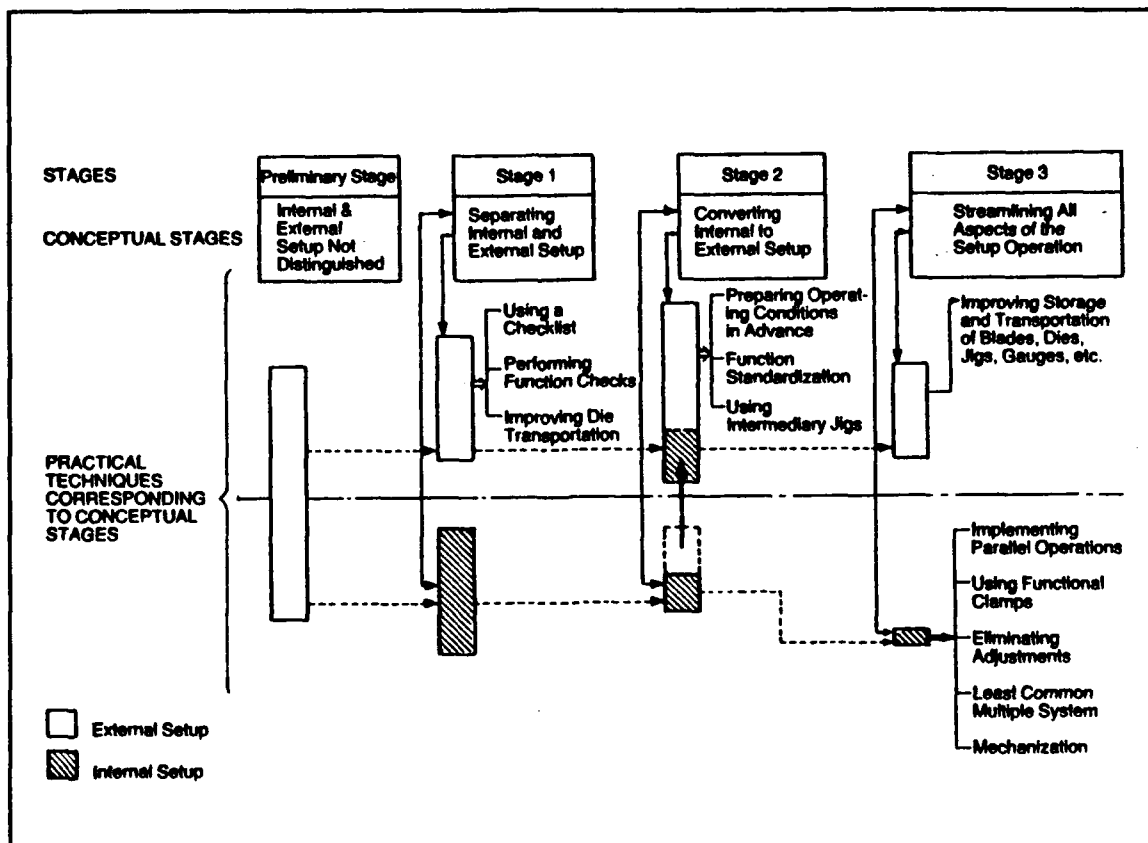

**Figure 1. Conceptual Stages and Effects for Setup Improvements**

To reduce a setup, it is necessary to analyze it first. For that purpose, we may use a stopwatch, worksample, or interviewing methods. A simpler way is to videotape the setup. Videotaping captures each detail of the setup process, and allows reruns. It is very effective because often the workers will come up with improvement ideas as soon as they see their own process on tape. Following videotaping, the operators can provide a description of events and make recommendations to achieve better setups.

Where work relations are strained, however, workers may be very resistant to any of the above methods. In some places good results have been achieved by letting the workers maintain possession of the tape, which prevented any misuse by management of the record the tape created. Once the workers learn by management's actions that the data is not going

to be used against them, more cooperation can be achieved. This, of course, is a general TQM issue, and not specific to SMED.

A very effective technique is to create a checklist for each setup. This helps in checking all preparations have been completed. For instance, frequent travelers have checklists they use to pack their bags for each trip. This saves a lot of setup time otherwise required to regenerate the list, and check the results. The same idea applies when we prepare the materials, parts and instruments required to perform a setup. Continually questioning why a setup activity is on the checklist is also important. Old ways of doing business cannot be allowed to overshadow the questioning of current procedures.

The use of visual controls can augment checklists, providing an indication of the availability of all tools or parts required for a particular setup at a glance. It is important to establish a specific checklist and table for each setup (including the items specific to that setup) and each machine (including items used for many setups on that machine). The Japanese have proven that visual aids can increase productivity and provide better communications to personnel than do complicated written instructions, which we support in America in the form of complex technical manuals. Visual controls may include: tool templates which contain drawings or outlines of tools required for a particular setup; boards showing status and location of dies, fixtures, and shop scheduling; and consolidated operating procedures found in one location as opposed to looking through several manuals. Color coding is also a form of visual control. For instance, when a press may be adjusted to three distinct dimensions, we can use notches on the controls that lock them in the right locations; we can mark each such location by a color, and a setup would entail putting all

the controls at the right color notch, with the same color marking the dies of that size.<sup>7</sup> These are but a few of the possibilities visual controls can provide [Gritzmacher, 1987].

We must also adopt a system for functional operation checks of tools and parts to complement checklists and visual controls. Once a machine has been stopped, it's too late to find out that a certain tool is defective, or that a nut is frozen. It should have been done as part of external setup. In fact, in most cases the right time to repair tools and fixtures is when the problem first occurs, i.e., after the setup during which the problem manifested itself for the first time. Be that as it may, we should not shut down a resource that could have been gainfully employed before accomplishing all external activities, including positioning material and tools in front of the machine and performing functional checks.

Although the first stage is capable of significant setup time reductions up to 50%, this alone will not achieve SMED's goal of setup reductions to under ten minutes. Further lead time reductions, typically 30%, may be achieved by converting internal activities to external activities. To do this, we must reexamine each elemental internal operation with an open-minded attitude and, if possible, develop a means of converting them to external setups. This stage often calls for investments in hardware, as well as thoughtware.

Though cost is a consideration, often the hardware required to transform an internal setup activity to an external one can be built in house cheaply.<sup>8</sup> The same observation

---

<sup>7</sup>US Naval Shipyards already have a color code in effect to mark various types of hazardous materials. This limits slightly the selection of colors that can be used to code setup materials.

<sup>8</sup>In government service there are three major issues that impact on the decision to make or buy. One, regulations require that when costing the make option all fixed costs should  
(continued...)

applies to many Stage 3 activities. Even when this is not the case, one still needs to compare the costs of reducing the setups to the alternative, e.g., buying new equipment, to decide whether the investment is justified. It is quite likely that on bottleneck machines such investments will be worthwhile almost always. Be that as it may, a low budget for hardware may be a good incentive to earnest searches for cheap solutions. Such cheap solutions also have a beneficial morale effects, because the workers are justifiably proud of them.

SMED espouses two methods to convert internal setup to external setup: (i) preparing operating conditions in advance of changeover; (ii) the use of intermediary jigs. The following examples illustrate each of these techniques.

#### **Preparing Operating Conditions in Advance**

The activities that can be converted from internal to external are often those associated with setting conditions such as temperature or pressure. For instance, setups in plastic molding may require that the new die be at a high temperature. Traditionally, this temperature was achieved by injecting a few parts and thus heating the mold. These parts, scrap, were then reused as raw material. When viewed narrowly, it is quite convincing that the heating operation is indeed internal, and cannot be externalized, because the machine

---

<sup>8</sup>(...continued)

be loaded; this is often misleading because often there is no other way to utilize the resources required for the make option at the relevant time, and thus there is no other way to recapture these fixed costs, i.e., they are sunk. Two, in an environment that still places a high premium on the lowest bid, the buy option is often synonymous with bad quality, and one way around having to buy bad quality is to make a better quality product at home. Three, almost invariably, the make option is associated with a much shorter lead time than the buy option. All three considerations above are in favor of the make option, if it is feasible at all.

actually has to be used with the new mold in order to bring its temperature to par. Nevertheless, it is possible to preheat the die before the changeover, and thus externalize this step. This preheating can be done by steam or electricity, but perhaps the best way to do it is to connect the next die to the coolant of the current mold, thus saving energy as well. Pressure, likewise, can be stored in tanks and imparted to the setup when necessary (the vacuum example mentioned above is a special case of storing pressure). The way to find such opportunities is to analyze the internal setup activities very carefully not only in terms of what is done, but also in terms of why is it done that way.

### **Intermediary Jigs**

Intermediary jigs are standard size jig (often shaped as plates) used to attach similar work pieces. As the machine processes one work piece, the operator or an assistant centers and prepares the next work piece as an external setup activity on a duplicate intermediary jig. When processing of the first work piece is complete, the second jig is ready for attachment to the machine. Intermediary jigs avoid preparation of the work piece on the machine during shutdown periods, reduce time required for centering operations on the resource, and reduce resource idle time. Figure 2 illustrates an intermediary jig (drill holder) for a drill. Originally, an operator attached the drill to a press at a specified angle during machine shutdown. Countersinking depth was critical, requiring micrometer measurements once cutting began. Using a drill dimensioning jig, drill cut depth is now preset during external setup operations. This reduces machine shutdown periods and micrometer measurements during operations. Another example of an intermediary jig is the extra table

that Shingo recommended using with the planer mentioned above.

Note that intermediary jigs do not require that the parts be standardized to be useful. Thus the use of intermediary jigs holds much promise for setups in job shop environments and repair shops such as naval shipyards. In fact, Mare Island Naval Shipyard is considering adopting a shop-wide intermediary jig program developed at FMC corporation, where practically every job is set up on an intermediary jig that attaches quickly by four specially designed bolts to most machines in the shop. In this case, the intermediary jig also makes possible transferring a setup from one machine to another, as well as relatively cheap preemption of a job, without losing the setup effort.<sup>9</sup>

### **Third Stage: Streamline Both Internal and External Setups**

Usually, the first two stages achieve setup reductions of around 80%, but are not enough to get us to the single digit goal. Furthermore, by themselves the first two stages often do not save any time at all, they just transfer it to external setup. The goal of the third stage is to streamline elemental operations in internal as well as external setup, and thus to finally reduce setup times to under ten minutes. This stage may be completed simultaneously

---

<sup>9</sup>Generally speaking, preempting jobs is an evil that arises because of lead-time quality problems, and creates a vicious cycle that exacerbates the problem that caused it in the first place. Thus preemption should not be encouraged. To the extent it exists, however, one is much better off if it does not involve losing the setup effort already invested in the current job (which is being preempted). Furthermore, if preemption becomes cheap, one may plan on running low priority jobs whenever a resource is free, and preempting when a high priority job arrives. Under such a system, preemption may become a viable sensible policy after all.



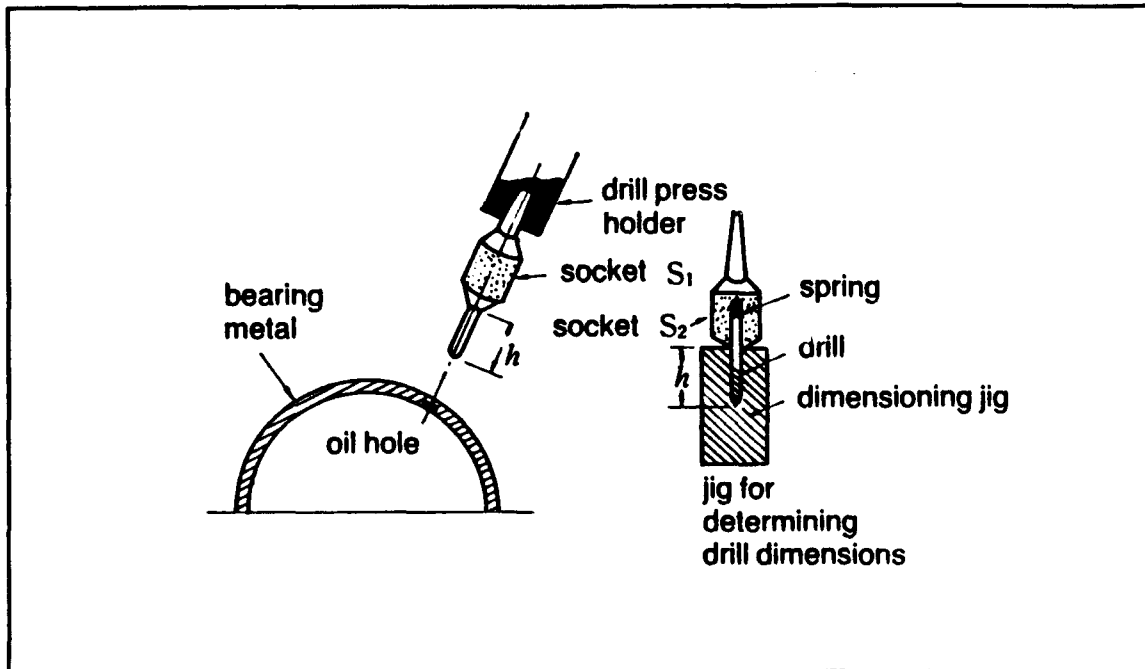

**Figure 2. Countersinking Operations using an Intermediary Jig**

with stage two above or as a separate stage--which Shingo recommends. The following are some generic ways to achieve the third stage objectives.

### **Streamlining External Setup Operations**

Improving identification, storage, and transportation of tools, dies, and parts are external setup streamlining actions. Having well-organized tool cabinets close to equipment, organized storage racks for dies, and conducting functional checks of tools and parts before turning off machines are all examples of this process. Other tools for streamlining external setup operations include visual controls in the form of tool or storage rack templates, color coding of tools and dies to aid in easy location and better organization, and transporting the material and tools to the machine before shutdown. We must eliminate the search for tools and the repair of parts during machine idle time. Nevertheless, by streamlining external

setup operations, the setup time itself is not reduced. To do that, we must streamline the internal setup operations.

### **Streamlining Internal Setup Operations**

Several tested methods for streamlining internal setup are available. They include the use of parallel functions, functional clamps, adjustments' elimination, and function standardization.

#### **Parallel Functions**

Parallel functions entail having more than one worker involved in completing setup operations. Oftentimes, one person may waste time in movement from one side of the machine to another during changeover operations. Teamwork during such operations could reduce setup time. For instance, we can divide work on a large machine into work required to the front and to the rear of the machine. For safety, this requires clear signals and, sometimes, the use of safety switches where a worker can prevent the other from endangering him or her. Visual aid charts can also provide a listing of detailed steps and signals to avoid confusion and safety problems. Parallel operations do not require additional personnel. Cross-training neighboring personnel or a floor supervisor to assist in parallel operations will relieve this problem, and the help is only needed during the short internal setup stage (the one that is supposed to be reduced to less than 10 minutes). The extra worker is usually justified in such cases.

## **Functional Clamps**

Functional clamping involves securing objects with the least amount of effort. We often use numerous turns of a screw to provide enough clamping resistance to secure a die or work piece. Yet, if the function required is clamping or holding, numerous turns are not required. We can reduce time and effort by minimizing motions to a single-turn, single-motion, or screwless (interlocking) fastening methods. The goal is to reduce the number of turns required for tightening operations to one at most. Figure 3 provides some examples.

## **Elimination of Adjustments**

The elimination of internal setup adjustments is crucial to ensure setup time reductions, as well as to improve the quality of the product. Shingo distinguishes between settings and adjustments. Settings involve the initial application of the die or work piece to the machine, and is thus a necessary operation. Adjustments involve correcting the position, and thus if we can get the setting right, there should be no need for them. Usually, however, adjustments can account for 50% of total setup time. Shingo illustrates several methods to eliminate adjustments: the use of standardized sizes for dies, so that the die can be attached without adjustment; the use of calibrated scales; avoiding the use of imaginary center line and reference points; and the use of the Least Common Multiple method. On a more detailed level, Shingo suggests that two washers should be used instead of one, perhaps with a drop of oil between them, because this prevents movement during the final tightening of the fastener.

The U-Shaped Washer Method

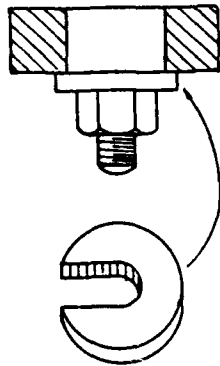

The U-Slot Method

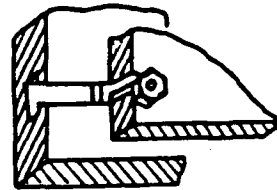

The Clamp Method

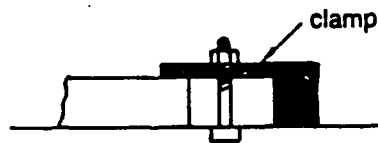

Spring Stops (one-motion)

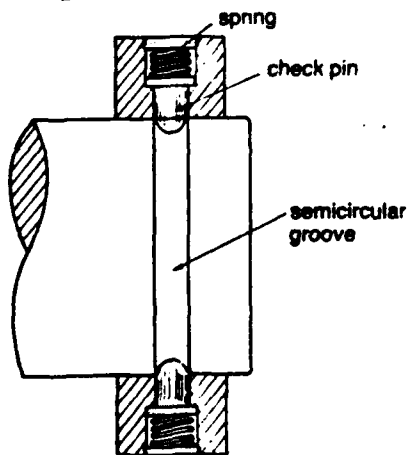

Interlocking Method

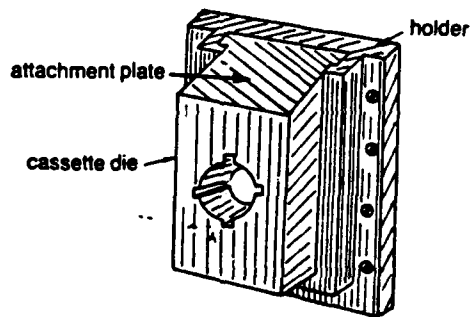
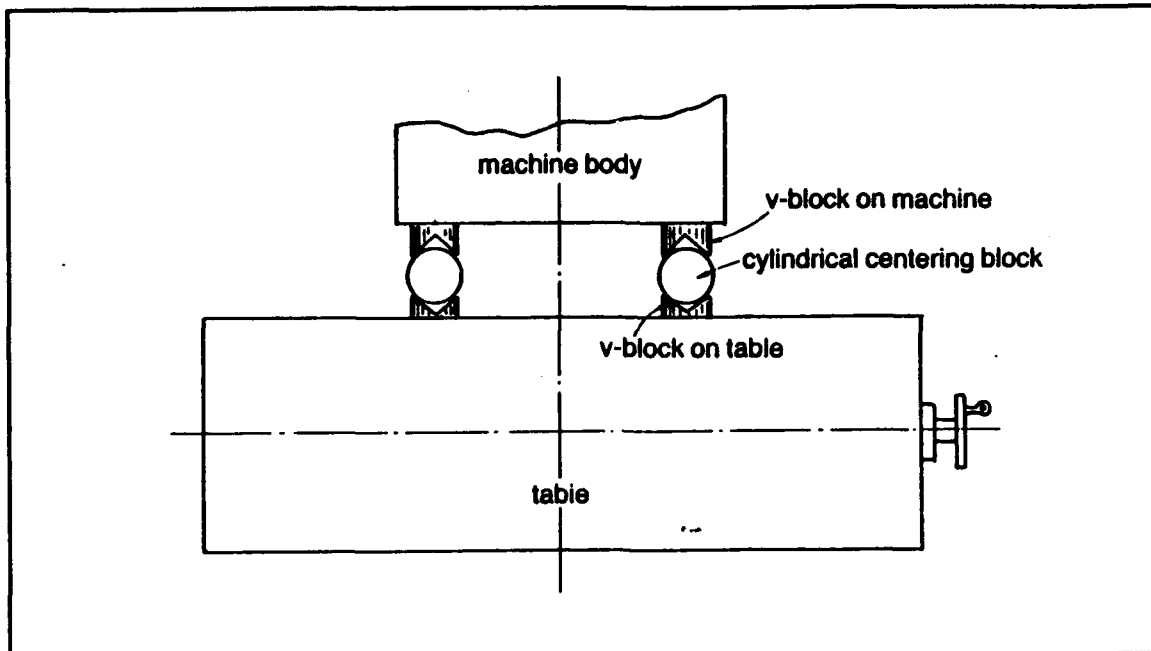

Figure 3. Examples of One-Turn/One-Motion Functional Clamping

(a) Calibrated Scales. By attaching calibrated scales on machines or by using a combination of a limited series of gauges, we can eliminate adjustments previously made by intuition. These actions simplify setups and reduce trial runs. Accuracies on the order of 0.5mm are possible with calibrated scales. Finer settings down to the order of 0.01mm (0.4 thousands of an inch) are possible with calipers or dial gauges. We can closely approximate settings during succeeding setups by simply marking setting positions on the machine. This procedure may not always suffice to eliminate adjustments totally, but even in the worst case it can reduce them significantly.

(b) Making Imaginary Center Lines or Reference Points Explicit. Using imaginary center lines causes much difficulty in setup operations. Instead of locating centers for each setup on the machine during shutdown periods, we can determine known reference points before changeover by a variety of methods. One such method is shown in Figure 4 for centering a machine table by using a centering jig fixed on the machine at a known distance from the desired center. V-shaped projections on this male jig when joined to the female jig already attached to the machine table assure proper centering as designed. Making imaginary centerlines or reference planes visible reduces adjustments to settings and simplifies skill levels required to perform the settings, resulting in reduced setup time. Figure 5 depicts dies with two different sizes, which implies adjustments are necessary when changing them. By standardizing the clamping height using shims welded to the dies it is possible to equalize their external dimensions, so no adjustments will be required when they



**Figure 4. Eliminating Adjustments With Centering Jigs**

are changed. This reduces the skill required to attach dies, simplifying setups and die management.

(c) Least Common Multiple System. The last technique proposed by Shingo to eliminate adjustments involves the Least Common Multiple System. This technique proposes making settings, not adjustments, by leaving the mechanism alone, and modifying only the function. The name [least common multiple system] refers to the notion of providing a number of mechanisms corresponding to the least common multiple of various operating conditions. The workers then perform only the functions required for a given operation.

One such example is shown in Figure 6. Here, a copying lathe required changing cylindrical templates which the mechanism traces and copies to similar cylindrical parts. By using the part shown in the figure, Shingo made it possible to complete the setup by just

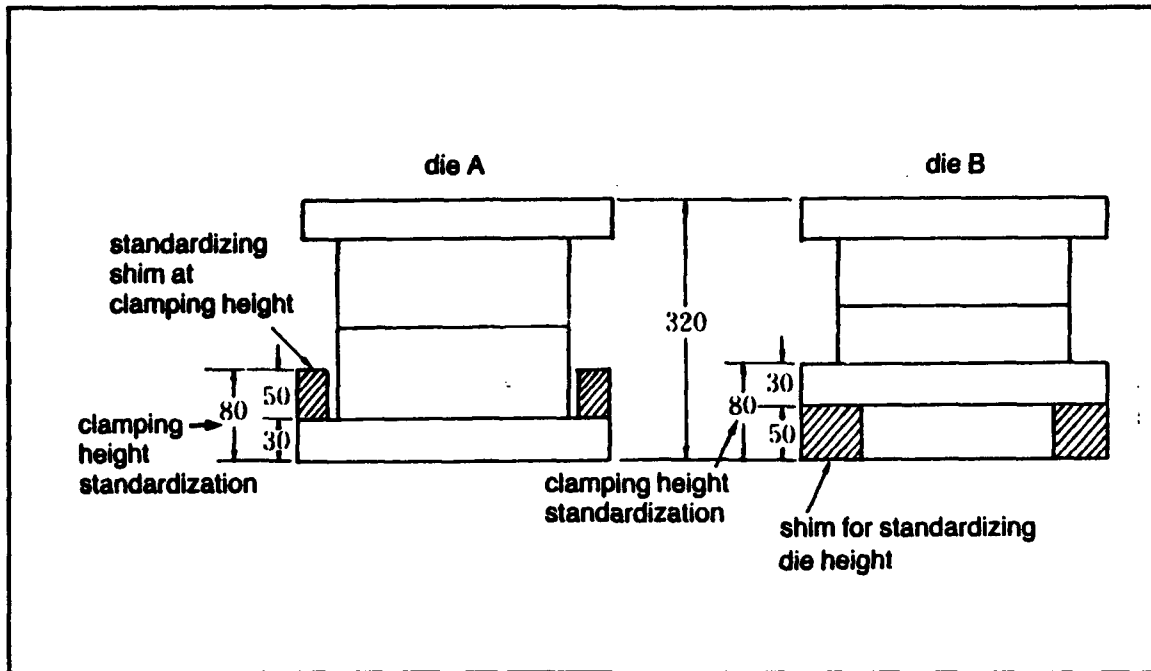
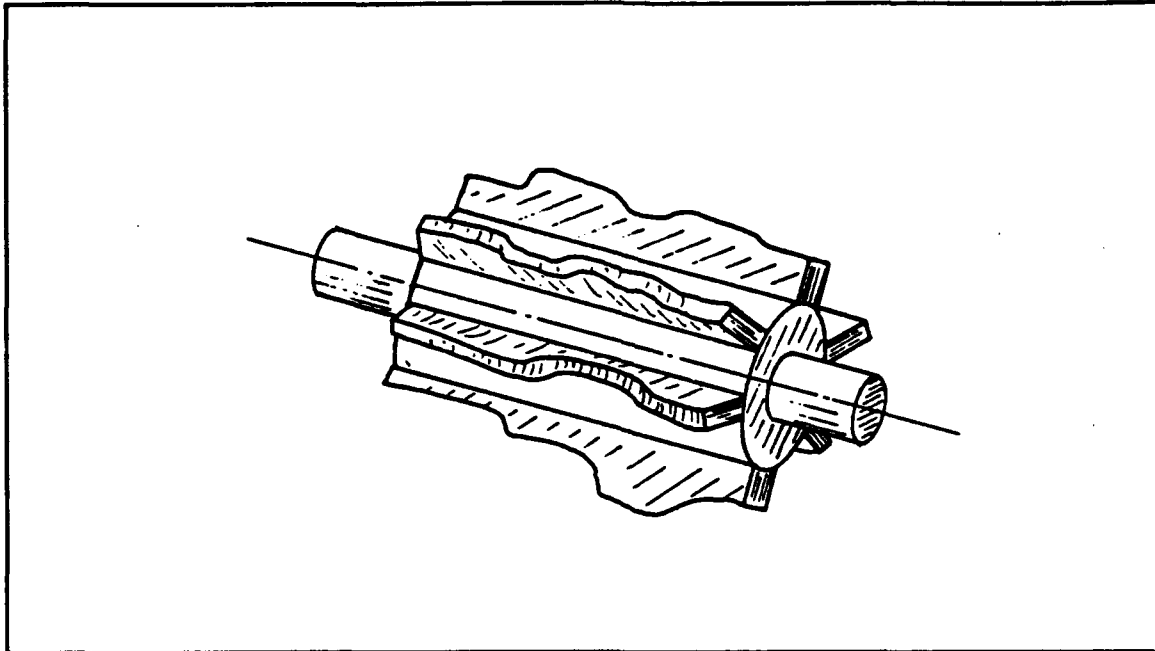

Figure 5. Function Standardization of Die Height and Clamping Edge

rotating the new template to the correct profile. As a result, this setup actually became an example of one touch change of die. It is an instance of modifying the function only, because the whole template need not be changed.

### Function Standardization

Function standardization calls for changing only those parts of a setup whose functions are different for each lot, and leaving the parts that are common to both setups intact. Efficient function standardization requires that we analyze the functions of each piece of apparatus, element by element, and replace the fewest possible parts. (This technique is particularly suited to a group technology environment, where setups tend to be similar to each other, and thus have many parts in common.)



**Figure 6. Least Common Multiple Technique**

### **SMED Techniques Specifically Suited for Job Shops**

In custom job shops and repair oriented job shops, such as Shop 31 in naval shipyards, many of the SMED techniques that are tailored to the repetitive manufacturing environment have limited use. That is not to say that such methods cannot be used at all. For instance, at Philadelphia Naval Shipyard, a mechanic has devised a setup system for machining chain links that have to be processed repetitively on an NC machine. In this setup each link is machined on two faces, and thus requires two setups. While the machine is working on one face of the link, the other setup is performed in parallel on a second part, and then the machine moves on to the second face of the second part, etc. This is an excellent example of a classic SMED application.



Though it is rare that a shop will have no recurring setups, to which the whole spectrum of SMED techniques can be applied, it is still true that most setups in this environment are not repetitive. Even then, some key SMED ideas still hold. In this section we list some examples, most of which are based on the experience gained at Mare Island Naval Shipyard. Most of these ideas were developed by a team headed by Dan Sunia (Machinist General Foreman, Mare Island NSY), with minimal help from this author.

### **Separating External and Internal Setups**

In general, even in a custom job shop environment, it is possible to anticipate the needs of the next setup and start working on it while the machine is working. This is especially important if there is a reason to use a particular machine, such as an NC machine which tends to yield higher quality products. Thus, all the activities that were mentioned above in this context apply. For instance, one should use check lists, transport setup equipment and perform function tests on equipment while the machine is working.

### **Converting Internal Setup to External Setup**

Perhaps the most promising technique for this purpose that is applicable to the job shop environment is the use of intermediary jigs. Shop 31 at Mare Island has started experimenting with an intermediary jig system developed at FMC, which applies to many types of machines (engine lathes being the notable exception). So far the experiment looks very promising. The idea is to attach a standardized plate to the table of the machine by four special fasteners, with the part to be machined set up on the plate. The next part can

be set up on a similar plate while the machine is working, and then attached to the machine in a very short time once it's free. This also makes possible moving a part from one machine to another without changing the setup.

Some of these plates have clamps attached to them permanently, in such a manner that when attached to a machine one face of the clamp (the stationary part) is preadjusted to a fixed reference line. When using two such clamps next to each other, it becomes possible to attach long pieces along the reference line without any adjustment. Without this improvement two clamps would be attached directly to the machine bed and would have to be adjusted to be parallel to the axis of the machine (which the reference line represents).

For repetitive parts, a standardized plate can be augmented by a fixture, designed specifically for the part. Using two such plates with fixtures makes possible setting the new part in the second fixture while the first part is being machined. This is the same idea utilized at Philadelphia Naval Shipyard that was described above, except for the use of a standardized plate to create an intermediary jig.

For non-repetitive parts, or small one-time batches of parts, one can create intermediary jigs that utilize modular fixtures, another idea that Mare Island is currently experimenting with. These modular fixtures utilize one-turn fasteners and prevent the need for irregular blocks that often prevail in the one-time setup environment. This is good for single parts, but it is especially useful for small batches that are not expected to be repeated. In such cases, assembling a modular fixture once can eliminate the need for separate adjustments for each part later. While assembling such a fixture typically takes more than an hour, note that this can be done in external setup.

### **Streamlining Internal and External Setups**

The most promising idea for streamlining internal setups in the job shop environment may be the use of one-turn fasteners, such as clamps. Note that the modular fixtures mentioned above speak to this issue as well, because they use such fasteners. The use of intermediate jigs also makes centering and dimensioning activities easier, so it also applies here.

By having tools and fixtures stored in such a way that one does not need to spend too much time looking for them, we can streamline the external setup. At Mare Island it was found that machinists spent at least 25% of their time in setup activities, and most of that time was spent looking for tools and fixtures. Therefore, they decided to invest in better storage of setup materials and tools. Using better quality tools also falls in this category, because it makes it easier to carry out the setup operations, both internal and external. Not having to, say, sharpen a tool is the ultimate streamlining of tool sharpening one can achieve.

### **SMED and Group Technology (GT)**

Group technology is concerned with sorting the product line to families, and assigning each family to a cell. This sortation is done based on similarities in manufacturing, so the machines in a cell fit all the parts of the family assigned to it. This is conducive to setup reductions in two ways: (i) the parts in a family tend to be of similar sizes and shapes, and thus require slightly less setup (e.g., one does not have to replace the chuck in a lathe if all

the parts in a family require the same size chuck); (ii) by assigning a subset of the parts to each cell, one reduces the number of potential setups each cell has to perform, thus making possible the application of SMED techniques that are usually associated with repetitive manufacturing. Thus SMED and GT are in synergy.

### **Prioritizing SMED Efforts**

There are two major types of resources involved in setups: people and machines. Much of the SMED theory is predicated on the assumption that machine time is at premium, and workers need to utilize the machines efficiently.<sup>10</sup> It turns out that for some machines this is a correct assumption, while for others the premium resource may be the workers. In either case, the above should not be interpreted in terms of values, but rather in terms of what's best to concentrate on to produce quality for a given system at a given time. When discussing the priority of SMED efforts we need to elaborate these issues a bit further.

In addition to the distinction above, it is important to remember that there are two distinct benefits to SMED applications: (i) reductions in setup time (the primary objective); (ii) improvement of quality due to better adjustments and prevention of scrap (a very welcome and important by-product). Below, we concentrate on prioritizing SMED efforts in terms of the primary objective only; i.e., where is it most important to reduce the setup time. Prioritizing improvements designed to improve quality in terms of good adjustment and lack of scrap should be addressed separately, especially since SMED is just one of the

---

<sup>10</sup>Shingo expresses the opposite opinion, that people are the most important asset. The remark above, however, is based on analyzing what SMED achieves, rather than what Shingo says.

techniques available for such purposes.

### **Bottlenecks, or Capacity Constraint Resources**

In general, every system has resources that limit its throughput. These resources are known as *bottlenecks*, or *capacity constraint resources* [Goldratt & Fox, 1986]. If one defines a system too narrowly, however, one may fail to find a bottleneck. For instance, in a shipyard it may happen that a particular department can serve more vessels than the shipyard as a whole can. Such a department cannot be a bottleneck, by definition, and so can't be any resource inside that department. If we look at the department as our system, then, we'll fail to find any bottleneck. In contrast, looking at the whole shipyard *plus* its vendors and customer base as the system will assure that at least one bottleneck resource will be in the system. Thus, when we talk about a particular department, e.g., Shop 31, it may or may not include a bottleneck resource in it.

Nevertheless, when a department has more equipment than it needs to satisfy all the demands placed on it, manpower is often reduced to match the demand, and in this situation workers become a bottleneck resource. Even then, some machines may behave as *de facto* bottlenecks, if the workers, or management, prefer to work them over the others. At shipyards today, many older machines are in such state of disrepair that they cannot hold tight tolerances. Not surprisingly then, the newer machines tend to be loaded to capacity, to maximize the number of items that do meet the tolerances. Thus, these good machines are bottlenecks in terms of tight tolerance capacity.

To continue, in a well-designed system a bottleneck will always be a resource that's

expensive to enhance. And it will be served by other, cheaper, resources which have enough capacity to at least make sure that the expensive bottleneck will be kept busy producing quality items that can be sold.

If the bottleneck is a machine, than using Shingo's definition of setup is most appropriate. In such a case we should stress all stages of SMED. The least important part of SMED in this case is streamlining the external setup, because this does not add capacity to the system, but this lack of importance is only in comparison to the activities that actually save bottleneck time.

If the bottleneck is manpower, than a quick analysis reveals that Stage 3, streamlining all setup operations, is the most important part of SMED we should concentrate on. This includes internal as well as external setups, because they both represent the usage of our scarce manpower resource. Note that most of the recommendations we made vis a vis job shop SMED activities fall into the category of utilizing manpower more efficiently, and are thus important regardless of whether the bottleneck is a machine.

### **Critical Activities or Time Bridges**

In PERT or CPM charts the resources that are on the critical path, i.e., dictate the duration of a project, may be referred to as "time bridges." As is the case with bottlenecks, if we define the system widely enough it will always have such time bridges. These are resources whose capacity may be more than enough, but they simply belong to chains of activities that together dictate the total time to process the items they need to process. Saving an hour on a critical path activity reduces the lead time of the system by one hour,

but need not necessarily increase the systems capacity. In contrast, saving an hour on a bottleneck resource gives us an hour's worth of additional capacity, but need not necessarily reduce our lead time (if the bottleneck is not on the critical path). As an example of a time bridge suppose we have to train pilots on clear days, and we spend several weeks for a clear day to manifest itself, then clear weather is a time bridge in the system. But if we have enough planes and instructors they do not necessarily limit our throughput.

### **When a Bottleneck is also a Time Bridge**

Time bridges may or may not be bottlenecks as well. When a bottleneck is also a time bridge, then there will typically be additional activities on the same critical path, both before and after the bottleneck, which are time bridges but not bottlenecks.

Proper bottleneck management calls for buffers ahead of the bottleneck, whose purpose is to prevent starving the bottleneck. Such starving of a bottleneck resource implies irreversible loss of production to the system. The size of these buffers is proportional to the unpredictability of the resources that feed it (but *not* the ones that it feeds). If these resources operate without any hitch, one does not need a buffer to protect the bottleneck against starvation; one simply plans on feeding the bottleneck on time. So, by smoothing the operations that feed bottlenecks we can afford to reduce the buffers protecting them. But note now that if a bottleneck is also a time bridge, then reducing the size of its buffer directly reduces the lead time of the system! Furthermore, by applying SMED to a resource we certainly reduce the variance of the time it takes to set it up. Thus, by applying SMED to a resource we also achieve a smoother output from it. So, applying SMED to time bridge

activities that feed bottlenecks that are also time bridges helps reduce the lead time directly (because they are time bridges) and indirectly (by making possible a reduction in the size of the buffer). Applying SMED to activities that are not time bridges themselves, but feed bottlenecks that are time bridges is also conducive to reduced lead time by making possible a reduced buffer in front of the bottleneck.

### **How to Prioritize Then?**

Based on the discussion above prioritizing SMED activities is different when the bottlenecks and time bridges are machines then when they are people. In the latter case we should concentrate on Stage 3 activities, i.e., streamlining setups, and do so everywhere. This is simply a better utilization of our scarce resource. In the former case a logical order is as follows:

- First Priority:** Bottleneck resources that are also time bridges
- Second Priority:** Other bottlenecks
- Third Priority:** Time bridges that feed bottlenecks that are also time bridges
- Fourth Priority:** Other time bridges
- Fifth Priority:** Activities that feed bottlenecks that are also time bridges
- Sixth Priority:** Activities that feed other bottlenecks
- Seventh Priority:** All others.

This order is based on the assumption that increasing capacity is more important than reducing lead time, which in turn is more important than reducing inventories that do not impact the lead time. Recall that if we have enough capacity there will be no bottlenecks,



and if our activities are not critical there will be no time bridges. So we are talking about adding capacity that can be used to sell more, and about reducing the lead time to the end customer.

The above priorities should apply to investing in hardware (money). Many SMED ideas only require thoughtware, and there is no reason whatsoever not to encourage all workers to apply thoughtware to their processes, regardless of their priority as per the above.

## **Conclusion**

SMED is a revolutionary way to approach production today and is applicable wherever setup operations occur. Flexibility of operations, increased productivity, decreased lead time, and zero inventory take on a new meaning with SMED applications.

Although setup time reductions are possible through mechanization, organizations should avoid this approach until attempts have been made to implement SMED and streamline current setup operations. It is much more effective to mechanize setups that have already been streamlined.

SMED's acceptance within organizations requires cultural change. For SMED to be effective, team work, creativity, and the desire to pursue continuous improvement must be common goals of each individual within the organization. The management system must also be open to change before taking advantage of the additional productivity potential offered by effective SMED applications. In this, SMED is similar to any other TQM implementation.

Nevertheless, SMED has the advantage of being an improvement process that is inherently conducive to other TQM improvements. It is very unlikely to fall into the trap of suboptimization while pursuing SMED. It is also usually possible to apply SMED in a department without much coordination with other departments and top management. That is, it is relatively easy to apply SMED on a local level. For these reason SMED is a very good type of TQM improvement to concentrate on during the initial stages of a TQM program, when it is important to demonstrate success to motivate the rest of the organization.

### References

Gavish, B., CM<sup>3</sup> (Computer Mediated Meeting Management), Vanderbilt University, Owen Graduate School of Management, Nashville, Tenn., 37203, 1992.

Goldratt, E. M. and Fox, R. E., *The Race*, North River Press, Inc., 1986.

Gritzmacher, K. J., "Visual Control Tools: A Hidden Productivity Factor?", *National Productivity Review*, Autumn, 1987, pp. 314-323.

Johansen, P. and McGuire, K. J., "A Lesson in SMED With Shigeo Shingo", *Industrial Engineering*, Vol. 8, No. 10, October 1986, pp. 26-28, 30, 32-33.

Shingo, S., *A Revolution in Manufacturing: The SMED System*, Productivity Press, 1985. (Originally published in Japanese as *Shinguru Dandori*, Japan Management Association, 1983.)

## APPENDIX

This appendix lists some observations the author was able to make during his Shop 31 visits at the Naval shipyards. These include visits to all eight Naval shipyards, namely at Charleston, Long Beach, Mare Island, Norfolk, Pearl Harbor, Philadelphia, Portsmouth and Puget Sound. Some of the positive findings are attributed to the shipyards where they were observed. Other opportunities for change, however, are not identified with shipyards for two reasons: (a) they tend to be generic; (b) the author was committed to avoid any potential use of this report to criticize particular shipyards.

### **Good ideas observed at shipyards:**

#### *Applications of group technology (GT):*

**Observation:** Charleston, under the leadership of Jeff Johnston, appears to be well ahead of the average in applying GT to the machine shop layout. To do that, they settled for less than perfect data analysis, by sampling parts based on verbal descriptions of the planners (say, a sample of all "plates," rather than a perfect coding scheme). A similar observation holds for Norfolk, where GT is also proceeding quickly without waiting for perfect analysis. At the same time, Mare Island is also advancing considerably in their own GT effort, which does involve intensive analysis.

**Recommendation:** The sooner we break the shop to smaller cells, the better. Fine-tuning, i.e., shifting a few machines from one cell to another or switching a part from one cell to another, should be done later. To hit the ideal layout right away is not a likely event regardless of the amount of analysis, whereas the immediate benefit of breaking the shop down to cells will probably pay for the costs before the formal analysis would have been finished. Be that as it may, the other shipyards might consider simply copying some of the cell configurations developed in these shipyards.

**Observation:** At three shipyards at least (Norfolk, Charleston and Mare Island) industrial engineers reside at the machine shop. In fact, at Norfolk they have several industrial engineers at the shop, under the leadership of Jim Tice, and at Mare Island there is a team of two industrial engineers. This creates much better communications and cooperation between engineers and planners and machinists; and engineering talent sits where it is needed, thus reducing planning lead times.

**Recommendation:** Adopt at all shipyards, and consider applying the same idea with design engineers, who currently are too remote from production. Likewise, purchasing personnel would also be able to serve the shops better by residing there, and specializing in purchases of the type the shops need. Resist any pressure to reverse this arrangement.

*Use of visual control tools:*

**Observation:** At Portsmouth a large lathe, used to machine propeller shafts, was marked in such a manner that the operator can tell the angle of rotation at a glance. This was done very simply by attaching small markers to the circumference of the chuck, marking the angle every 45°

**Recommendation:** Adopt this practice for all large lathes, including vertical lathes. In addition, attach a scale to the length of engine lathes to facilitate setup and operation. Once such a scale exists, a diagram denoting the offset along it would greatly facilitate setup and operation of the lathe, especially for workers who usually operate other machines.

**Observation:** At Pearl Harbor a scale was attached to the bridge of the bridge crane, making it possible to adjust the crane to a prespecified position with ease. A similar scale marks the location of the bridge along the shop. Thus, the crane can be brought to any specified position with ease.

**Recommendation:** Copy. In addition, look for ways to improve the fine adjustment of these cranes, which seems to be a problem.

## **Other opportunities for change at shipyards:**

**Observation:** Lack of perceived management commitment

**Discussion:** Complaints against management's lack of cooperation came up typically. This is not to imply that management has the power to correct everything the floor personnel think it should: it too is limited by the system. It does say that Deming is right: quality starts at the top, however high the top may be. Many participants in the seminars said they would like to implement the ideas presented, but did not believe management would support them, and therefore did not feel empowered to do so. Others concentrated on what they *could* do, which is not insignificant considering that many of the ideas require thoughtware only. The main evidence for lack of management commitment was in complaints about lack of action on safety issues that were raised (even while telling the workers that safety was everybody's job) and complaints about budget cuts that were allowed to kill preventive maintenance in the shops. (More on preventive maintenance later.)

**Recommendation:** This is a major TQM issue. Management needs not only to listen to workers, but also to respond. TQM coordinators should strive to make this happen. A technical tool that might help is an electronic network which makes it possible to communicate anonymously with management. Such tools exist today; for instance, see Gavish 1992, which describes and promotes a particularly advanced product of this type developed at Vanderbilt University.

**Observation:** Lack of preventive maintenance (PM)

**Discussion:** Preventive maintenance is painfully lacking. It seems it was the first area to suffer under past budget cuts, and never recovered. Some shipyards are doing a better job with their newer machines--for which they have an outside maintenance contract--but gave up on the old ones. What is done, though, is that important old machines get sent to be rebuilt completely, after having been neglected for a long time.

When machines are out of alignment they will not hold jobs to pre-qualified positions. When fasteners are allowed to become loose or when bearings are allowed to deteriorate the machine vibrates more and cannot hold the tolerances it was designed to hold. The resulting quality problems are difficult to measure, but definitely large. One of these resulting quality problems is that machinists no longer use the machine for precision work, and thus the newer machines get excessively loaded. This in turn leads to persistent requirements to purchase new machines which might not have been needed had the old ones been properly maintained.

Furthermore, When a machine starts vibrating due to fasteners that are not tight or bearings that are deteriorated, it is possible to fix it relatively easily and cheaply. The machinists themselves could be trained to do that. But if allowed to continue working this way it will not only produce parts of lesser quality, but also damage the shafts. Once shafts are bent, it is much more difficult to repair the machine. In fact, most shipyards allowed their old machines to reach such a stage, and now their choice is whether to scrap the machine or overhaul it at huge costs.

These overhauls, invariably, are done by contractors outside the shipyard and involve expensive transportation of the machines. At the same time, the shop itself may have the technical capacity of doing the overhaul, but due to obsolete make-or-buy decision rules the shops resources will be allowed to idle, and the job will go out. This is the lesser evil. More serious evil occurs when the machine is not fixed due to lack of budget, but at the same time the necessary resources that could be used to fix it at virtually zero marginal cost are idle.

**Recommendation:** Train machinists to do their own preventive maintenance and pursue it vigorously. Trigger should be quality of work produced by machine, and periodic checks of fasteners. Allow shipyards to overhaul and upgrade their own equipment during slack periods.

**Observation:** Storage of setup materials is not satisfactory

**Discussion:** At most shipyards, setup materials are stored in such a manner that excessive time is wasted locating them and/or planning and carrying out alternative ways to set items up when the preferred setup items are not located after all. Indeed, at Mare Island the first action taken to implement SMED was improving the storage<sup>11</sup>. Note that in some areas of most shops the storage is better than average, but no single shop was well organized throughout.

**Recommendation:** Invest thought and hardware to alleviate the problem. Consider the use of visual controls (e.g., tool templates, pictorial lists of materials in opaque cabinets) and color coding.

**Observation:** Lack of setup items causes hoarding

**Discussion:** When machinists know there will be enough setup items to support their work, they will return these items to the proper location when done. When they know that setup items are in short supply, some machinists will hide these items for their personal use. For instance, in one shipyard there were two chucks available for a particular type of work, and machinists could usually get one when they needed it. One of the chucks was damaged during work, however, and the very next day the other one disappeared. (It was later recovered from one of the machinists personal tool storage areas.)

**Recommendation:** Rather than just treating the symptom (by tighter controls), the core problem should be addressed, i.e., there should be enough setup materials to support the

---

<sup>11</sup>According to Dan Sunia, Machinist General Foreman, Mare Island NSY, who leads the SMED implementation project at Shop 31, 26% of machinists' time was spent just looking for setup materials, and another 20% was spent actually setting up. By better storage of setup materials they hope to eliminate the former almost totally. Combined with SMED methods to reduce the 20% by half, he expects to achieve total savings of 33%. This is equivalent to increasing the number of machinists by 50%. Indeed, visiting Shop 31 at Mare Island after an absence of a few months, this author was highly impressed with how much better organized the place has become recently.

work. This includes ample supply of modular fixturing items. As for control, a color code could be used to mark items that belong to particular areas, to discourage uncontrolled tool migrations.

**Observation:** Lack of small hoisting and transporting equipment

**Discussion:** In many shipyards there are no jib cranes or other small cranes. In most cases they were removed when the CNC machinery was installed (a step in the direction opposite to group technology, which constituted sub-optimization of the severe type: spend money to hurt the system). Some of the jib cranes that are still installed in some shipyards are not in working condition (PM, again). Replacing jib cranes by central cranes is a quintessential example of sub-optimization of the severe type. Many hours are wasted waiting for the crane. Sometimes the crane does not arrive because it is busy elsewhere. At other times the problem is lack of licensed operators; but this is a task that most machinists could be trained to perform and be licensed for.

**Recommendation:** License many machinists to operate bridge crane<sup>12</sup>; acquire jib cranes, mobile cranes, hand dollies etc.

**Observation:** In some shops they no longer have the capacity to perform small welding jobs. This causes long delays for some jobs.

**Recommendation:** Employ some machinist/welders who are cross trained in both trades, and who would be able to support the shop with occasional small welding jobs without having to go outside the shop.

**Observation:** CNC machinists typically watch the machine idly instead of working in parallel

---

<sup>12</sup>Credit for this suggestion is due to John Whitmore, a machinist from Philadelphia NSY. He also suggested the idea of having some machinists qualify as in-shop welders.



**Discussion:** CNC machines are supposed to operate automatically once programmed and stop in case of trouble (e.g., broken tool). Thus, the machinist should be able to perform other tasks in parallel to the machine working, such as, programming for the next job or setting the next job up on the extra pallet (when one exists). At some shops the problem stems from not having opted to purchase the fail-safe gadgets that stop the machine in case of trouble. In contrast, modern facilities have one machinist oversee up to 15 machines. These machines rarely stop, and when they do it's not a big issue if it takes the machinist a few minutes to arrive.

**Recommendation:** Maximize opportunities for machinists to work in parallel to the machine. Where necessary, purchase the fail-safe gadgets.

**Observation:** Unwittingly moving away from group technology

**Discussion:** Though there are instances where the shops are doing the right things in terms of group technology, as listed above, there are also instances where, over the years, they have been moving in the opposite direction. Some of the problems mentioned above fall into this category, most notably the removal of welding capabilities from shops and the removal of jib cranes. The following conversation with Ray, a veteran machinist, speaks to the same generic problem:

"We used to have storage of fasteners and straps right next to each machine, sorted out by size and color. It was visually clear and well maintained by the machinists who 'owned it'. This has been changed, though, by one of the new managers who came aboard, and now we have cabinets that we cannot see through, far from the machines, with fasteners mixed together haphazardly, some of them bent or stripped, and it takes forever to locate what you need. Also, nobody knows if you got too few or too many of each size. There's no color coding whatsoever. When damaged, T-slot bolts do not get straightened out, and when stripped they do not get replaced.

"Jib cranes can help a lot, but they were removed."

At the same shipyard, the General foreman of the valve repair section related that in the past he had a lathe and a milling machine at his disposal, and lost them when they moved to a new building. At that time it was judged that the valve repair section was close

enough to the machining section. Now, says he, the machines are lost forever, and the lead time increases.

The most time consuming item in the valve repair process, according to the same general foreman, is to get engineering to sign off on the repair. The engineers are far away, and their process includes 92 steps and a multitude of signatures. The machinist can do the job 99% of the time, as long as the regulations are clear, but they are not allowed to, and are not funded to. It's also not likely that the engineer will reside downstairs at the repair area any time soon, so we really ensure the perpetuation of this problem. It is important to note that these valves are often on the ship's critical path, so reducing their turn around time is extremely important. The engineer may think it's a valve that awaits processing, but in reality it is often a ship that's waiting.

**Recommendation:** Reverse all "improvement projects" that take capabilities away from where they are needed to central locations. Instead, embark on projects that bring capability to where it is needed, especially in areas that are often critical. For example, change the inspection of valves and similar items by qualifying the machinists to perform it when it is clear-cut, engineer to arrive and do it for exceptional cases. Indeed, requiring a multitude of signatures just means that nobody is really responsible: the process should be simplified. (And see recommendation above to have some engineers reside at the shops.)

**Observation:** Planners plan new jobs (though that plan is rarely good enough for actual execution) and also worry about the financing. Their double duty there just adds lead-time to the job, because typically the job has to be planned again by the programmers. Therefore, by the time the job reaches the floor it's already a hot job.

**Recommendation:**<sup>13</sup> Programmers should work in parallel to the office on the planning. Chances are the job will be funded and their efforts will be utilized. This way, the total planning time will be reduced, and--most importantly--the job will be finished earlier.

---

<sup>13</sup>Credit for this idea is due to Jim Horgan, Norfolk NSY.

### Distribution List

<u>Agency</u>	<u>No. of copies</u>
Defense Technical Information Center Cameron Station Alexandria, VA 22314	2
Dudley Knox Library, Code 0142 Naval Postgraduate School Monterey, CA 93943	2
Office of Research Administration Code 08 Naval Postgraduate School Monterey, CA 93943	1
Library, Center for Naval Analyses 4401 Ford Avenue Alexandria, VA 22302-0258	1
Department of Administrative Sciences Library Code AS Naval Postgraduate School Monterey, CA 93943	6
Prof. Dan Trietsch Code AS/Tr Administrative Sciences Department Naval Postgraduate School Monterey, Ca. 93943	100
Commander Naval Sea Systems Command Washington, D. C. 20362	10