



AD-A255 812

2



DOT/FAA/CT-90/21

FAA Technical Center
Atlantic City International Airport
N.J. 08405

Aircraft Command in Emergency Situations (ACES) Phase I: Concept Development

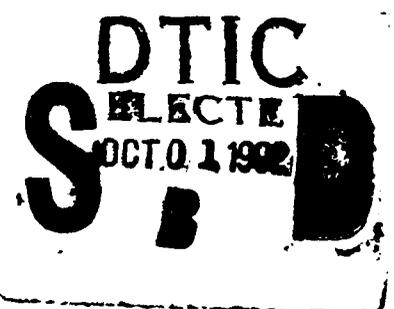

April 1991

Final Report

This document is available to the U.S. public
through the National Technical Information
Service, Springfield, Virginia 22161

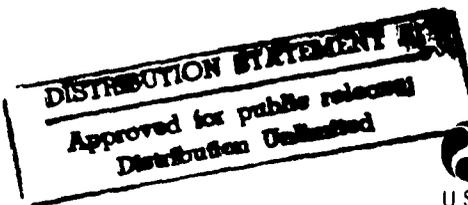

U.S. Department of Transportation
Federal Aviation Administration

92-26307
370145
12504

92 26307

NOTICE

This document is disseminated under the sponsorship of the U. S. Department of Transportation in the interest of information exchange. The United States Government assumes no liability for the contents or use thereof.

The United States Government does not endorse products or manufacturers. Trade or manufacturers' names appear herein solely because they are considered essential to the objective of this report.

Technical Report Documentation Page

1. Report No. DOT/FAA/CT-90/21		2. Government Accession No.		3. Recipient's Catalog No.	
4. Title and Subtitle Aircraft Command in Emergency Situations (ACES) Phase 1: Concept Development				5. Report Date April 1991	
				6. Performing Organization Code	
				8. Performing Organization Report No.	
7. Author's Thomas L. Reynolds, Gregory E. Grimstad, Charles D. Anderson				10. Work Unit No. (TRAIS)	
9. Performing Organization Name and Address Boeing Commercial Airplane Group Advanced Programs – Payloads P.O. Box 3707 Seattle, Washington 98124-2207				11. Contract or Grant No. DTFA03-89-C-00061	
				13. Type of Report and Period Covered Final Report (Phase 1)	
				14. Sponsoring Agency Code ACD-240	
12. Sponsoring Agency Name and Address U.S. Department of Transportation Federal Aviation Administration Technical Center Atlanta City International Airport, NJ 08405					
15. Supplementary Notes The FAATC Contracting Officer Technical Representative (COTR) is Dr. Thor Eklund, Telephone (609) 484-5322					
16. Abstract This contract study defined two conceptual approaches for an advanced smoke/fire detection system for commercial passenger jet aircraft that would provide for accurate, timely guidance to the flight crew for their use in responding to possible and/or actual inflight smoke and fire events within the pressurized fuselage. The motivation for this work has been the computerization of the modern commercial jet aircraft flight deck, the evolution toward the two-man crew, and documented times taken to locate and implement the appropriate emergency procedure. The primary objective of the ACES system concepts are to provide the capability to reduce the time required for the flight deck crew to make a decision to land the aircraft.					
17. Key Words Smoke detection Passenger cabin Fire detection Cabin safety Crew alerting Emergency evacuation Inflight fire				18. Distribution Statement This document is available to the public through the National Technical Information Service, Springfield, Virginia 22161	
19. Security Classif. (of this report) Unclassified		20. Security Classif. (of this page) Unclassified		21. No. of Pages 133	22. Price

Preface

This report describes the results of a concept definition study of an advanced smoke and fire detection system that would assist in the detection and management of inflight emergencies aboard commercial jet aircraft. The system, known as "Aircraft Command in Emergency Situations (ACES)" (Phase I) was conducted by the Boeing Commercial Airplane Group, Advanced Programs, Payload Systems, under contract to the U.S. Department of Transportation, Federal Aviation Administration (FAA) Technical Center, Atlantic City, New Jersey between October 1989 and July 1990.

Dr. Thor Eklund was assigned as the FAATC Contract Officer Technical Representative (COTR). Dr. Eklund provided invaluable insight into the background and physics of aircraft type fires, previous research, current FAA activities and future research interests. His help and assistance has been welcomed and greatly appreciated.

Boeing personnel participating in the study included: Tom Reynolds, Program Manager; Greg Grimstad, Principle Investigator; Chuck Anderson, Flight Deck Research; Cathy Rider, Payloads Documentation; Mike McCloskey, Electrical Engineering; Ken Kreig, Payloads; Drew Anderson, Product Safety; Ernie Campbell, Flight Operations; Dr. Jim Peterson, Materiel Technology; Danella Hastings, Contracts; and Cindy Edgerton and Marge Apels, Business Management.

The contribution of several commercial companies and their staffs engaged in fire detection and advanced research is gratefully acknowledged and appreciated:

- Darchem Engineering Ltd., Stockton-on-Tees, UK
- Fike Fire Suppression Systems, Blue Springs, MO
- Fire and Safety International, Berkshire, UK
- Gamewell, Cedar Knolls, NJ
- Geomatic Control System AB, Gotenborg, Sweden
- HTL/Pacific Scientific, Duarte, CA
- Jamco Corporation, Tokyo, Japan
- Pellew Engineering, Maralsburg, R.S.A.
- Schlumberger Industries, Hampshire, UK
- York, V.S.O.P., Hampshire, UK

DTIC QUALITY INSPECTED 3

Accession For	
NTIS GRA&I	<input checked="" type="checkbox"/>
DTIC TAB	<input type="checkbox"/>
Unannounced	<input type="checkbox"/>
Justification _____	
By _____	
Distribution/	
Availability Codes	
Dist	Avail and/or Special
A-1	



Table of Contents

1. INTRODUCTION	1
1.1 BACKGROUND	1
1.2 PREVIOUS STUDIES	4
1.3 PURPOSE	4
2. SCOPE	4
2.1 OBJECTIVES OF STUDY	5
2.2 STUDY CGNSTRAINTS	6
2.3 APPLICATION OF DUNLAP SCENARIOS	6
3. BASELINE AIRCRAFT	9
3.1 GENERAL DESCRIPTION	9
3.2 BASELINE DETECTOR TYPES	11
3.3 LOCATIONS MONITORED	12
3.4 SYSTEM REQUIREMENTS	17
3.5 FLIGHT DECK CONFIGURATION	18
3.6 AIRBUS DETECTION SYSTEM	22
4. TECHNICAL APPROACH	23
4.1 ACCIDENT STUDY DATA	24
4.2 FIRE SIGNATURES	28
4.3 SENSOR TECHNOLOGY	31
4.4 FLIGHT DECK DESIGN APPROACH	33
5. CONCEPT A	38
5.1 GENERAL DESCRIPTION	38
5.2 DETECTOR TYPES	40
5.3 LOCATIONS MONITORED	43
5.4 SYSTEM REQUIREMENTS	50
5.5 FLIGHT DECK DESIGN	52
5.6 CREW PROCEDURES	57
5.7 SYSTEM INSTALLATION COST	58

Table of Contents (*Continued*)

6. CONCEPT B	60
6.1 GENERAL DESCRIPTION	60
6.2 DETECTOR TYPES	61
6.3 LOCATIONS MONITORED	66
6.4 SYSTEM REQUIREMENTS	69
6.5 FLIGHT DECK DESIGN	70
6.6 CREW PROCEDURES	75
6.7 SYSTEM INSTALLATION COST	76
7. CONCEPT PERFORMANCE EVALUATIONS	77
7.1 DUNLAP SCENARIO EVALUATIONS	77
8. CONCLUSIONS	92

Appendices

APPENDIX A SMOKE AND FIRE DETECTOR SUMMARY	95
APPENDIX B 757-200 GENERAL DESCRIPTION	98
APPENDIX C SOFTWARE DESIGN ARCHITECTURE	103

List of Figures

2-1	Scenario Data	7
3-1	757-200 Flight Deck EICAS Display	9
3-2	757-200 Fire Protection Systems	10
3-3	Autronics Photoelectric Smoke Detector	11
3-4	Existing 757-200 Fuselage Fire Protection System	12
3-5	757-200 Cargo Compartment Fire Protection	13
3-6	757-200 Cargo Compartment Smoke Detector Installation	14
3-7	Lavatory Ionization Smoke Detector	15
3-8	Equipment Cooling, Ventilation Systems and Smoke Detectors	16
3-9	Sensor Outputs to the Caution and Warning System	18
3-10	Central Crew Alerting System	20
3-11	Communications Handset	22
4-1	Total Smoke/Fire Incidents	24
4-2	Inflight Smoke/Fire Incidents	25
4-3	Lavatory – Inflight Smoke/Fire Incidents	26
4-4	Passenger Cabin – Inflight Smoke/Fire Incidents	27
4-5	Cargo Compartment – Inflight Smoke/Fire Incidents	28
4-6	The Four Stages of Fire	29
4-7	Particle Size Ranges for Common Aerosols	30
4-8	Ionization Detector	31
4-9	Light Attenuation Type Photoelectric Smoke Detector	32
4-10	ACES Context Diagram	37
4-11	The Overall Structure Diagram of ACES	37
4-12	ACES Knowledge Base Partition	38
5-1	ACES Concept A	39
5-2	Gamewell Consecutive Pulse Photoelectric Detector	42
5-3	Geamatic Light Attenuation Photoelectric Detector	42
5-4	Lower Cargo Compartments	43
5-5	Cargo Compartment Detection System	44
5-6	Concept A Modification – Lavatory Features	45

List of Figures (Continued)

5-7	Jamco Ionization Smoke Detector PU90-461	46
5-8	Attic Detectors	47
5-9	Air-Conditioning System	48
5-10	Conditioned Air Smoke Detection System	49
5-11	Smoke Detector Galley Area Ceiling	50
5-12	Format for the Electronic Checklist – Aft Cargo Fire Checklist	52
5-13	Page Two of the Aft Cargo Fire Checklist	53
5-14	Cabin Attendant Panel – Aft Lavatory Smoke Alert	55
5-15	Cabin Attendant Panel – After Attendant Response	56
5-16	Cabin Attendant Panel – Circuit/Lamp Test	57
6-1	ACES Concept B	61
6-2	Fike Analog Photoelectric Detector	63
6-3	Schematic Layout of the York Fiber-Optic DTS System	64
6-4	Schlumbergher Acoustic Thermal Monitoring System	65
6-5	Pellew Combi/Freighter Smoke Detection System	68
6-6	Combi/Freighter Main Deck Cargo Bay Fire Protection System	69
6-7	Inflight Diversion Planner Display Format	72
6-8	Inflight Diversion Planner Format for Weather Information	73
6-9	Synoptic Display Layout for Concept B	74
6-10	Synoptic Display – Sensor Signatures	74

List of Tables

1-1	Transport Aircraft Fire Safety Rulemaking	2
2-1	ACES System Configurations	5
3-1	Baseline 757-200 Component Costs	13
3-2	Alerting Categorization	19
3-3	Alerting System Categorization	21
5-1	Concept A 757-200 Component Costs	40
5-2	ACES Production Estimate	59
6-1	Concept B Component Costs	62

List of Acronyms

A/C	- Air-Conditioning	EICAS	- Engine Indications and Crew Alerting System
ACES	- Aircraft Command in Emergency Situations	EMI	- Electromagnetic Interference
ACP	- Area Call Panel	ETE	- Estimated Time Enroute
AFLOTS	- Automatic Fire/Overheat Logic Test System	F/D	- Flight Deck
AGL	- Above Ground Level	F/F	- Fire Fighter
AIP	- Attendant Indication Panel	FAA	- Federal Aviation Authority
APU	- Auxiliary Power Unit	FAATC	- Federal Aviation Administration Technical Center
ARINC	- Aeronautical Radio Incorporated	FAP	- Forward Attendant Panel
ASHRAE	- American Society of Heating Refrigeration and Air-Conditioning Engineers	FAR	- Federal Aviation Regulation
Attn	- Attendant	FMC	- Flight Management Computer
BIT	- Built-In Test	I/O	- Input/Output
CAR	- Civil Air Regulation	IR&D	- Independent Research and Development
CFDS	- Centralized Fault Display System	IR	- Infrared
CO	- Carbon Monoxide	LED	- Light Emitting Diode
COTR	- Contract Officer Technical Representative	MW/C	- Master Warning/Caution
CRT	- Cathode Ray Tube	MEL	- Minimum Equipment List
DATAAC	- Digital Autonomous Terminal Access Communication	MTBF	- Mean Time Between Failure
DOT	- Department of Transportation	NASA	- National Aeronautics and Space Administration
DTS	- Distributed Temperature Sensor	PBE	- Protective Breathing Equipment
E/E	- Electronic Equipment	P/N	- Part Number
ECAM	- Electronic Centralized Aircraft Monitoring	QRH	- Quick Reference Handbook
ECS	- Environmental Control System	R&D	- Research and Development
		RLS	- Remote Light Sensor
		STA	- Station

Executive Summary

Aircraft Command in Emergency Situation (ACES)

Boeing Commercial Airplane Group, Advanced Programs, Payload Systems, performed this product development study for the Federal Aviation Administration Technical Center (FAATC), Atlantic City International Airport, New Jersey, under contract No. DTFA03-89-C-00061. The genesis for this study arises from the FAA's concern for early detection and control of inflight smoke/fire incidents aboard commercial jet aircraft. The motivation for this product development study is the computerization of the modern commercial jet aircraft flight deck, the evolution toward the two-person flight deck crew, and the documented times taken to locate and correctly implement the appropriate emergency procedures during past accidents. The purpose of this contract was to conduct a product definition study that would identify two systems and associated hardware that would provide for the faster detection and identification of an inflight smoke/fire event and, hence, a faster crew response. The primary objective of an ACES-type system is to provide a capability for decreasing the time needed to make a decision to land at the nearest suitable airport.

In developing the ACES system concepts, a four-step process was used: 1) review of aircraft requirements and previous studies; 2) develop the necessary database on currently available and new sensors and detectors; 3) develop the "concept" requirements for each of the proposed detection approaches; and, 4) identify the necessary flight deck interface requirements for both sensor system status and communications. The Boeing 757-200 was selected as the baseline aircraft for the study model. Both of the ACES concepts were then applied to the baseline model for comparative purposes and analyzed against scenarios identified and defined in a previous FAATC contract. The installed cost of each ACES concept was estimated for development and installation cost impact on current production 757-200 aircraft. Costs were estimated for block change implementation in current year (1990) dollars. Retrofitting to existing aircraft is beyond the scope of this study and not considered part of this cost analysis.

The technology studied in support of the ACES concepts centered primarily on new and improved sensor and detector technology and the improvements in flight deck operations which could be realized with changes in computer and display technology.

The two concepts developed are: Concept A, which included new types of ionization and photoelectric smoke/fire detectors with additional areas selected for coverage within the pressurized fuselage, and a electronic checklist to present the flight deck with emergency procedures. Concept B expands on the detection capability of Concept A; more areas are to be monitored, greater use of analog and digital sensors, thermal detection and monitoring capability (acoustic wire and fiber optic), and an Inflight Diversion Planner on the flight deck to assist, if necessary, in diverting to an alternate airport.

Both of the ACES concepts addressed four specific areas that had been previously identified as having potential for significant improvements. These areas were:

Sensing - Identify sensors which, through design improvements, have increased overall system reliability and improved capabilities, and which will reduce the potential for false alarms by trend monitoring and concurrence of other sensors. The incidence of false alarms has been found to be one of the main causes which delays the decision to divert to alternate airports.

Alerting - The quality of information to the flight deck can be improved by providing more definitive data and improving the communications between the flight deck and cabin crew. New automated systems have been identified which can respond faster with more qualitative information such as the type and location of the event.

Crew response - Crew response can be significantly improved with the implementation of an automated emergency procedure checklist. These checklists are keyed to the type and location of the smoke/fire event and are available immediately after an alarm is initiated. Additional improvements can be realized in the verbal and nonverbal communication between the flight deck and cabin crew with the implementation of a new cabin attendants panel that will interface with the flight management system.

Crew decision making - Flight deck crews are required to make several key decisions once an alarm or alert is sounded. Most often these decisions are sequential in nature with periods of time used for diagnostics and analysis. The delays incurred to confirm the alert also delay initiating a response. An electronic checklist called up by the flight management computer when an alarm is initiated saves the crew time in locating emergency reference handbooks and starting the emergency procedure. The Boeing-developed electronic checklist provides a listing of the emergency procedure steps which must be initiated, tracks each function that is in progress, and displays those functions which have been completed. If a decision is made to divert to an alternate airport, an automated Inflight Planner can be selected to display information on alternate airports along the flight path, flying time to each airport, weather conditions, runway status, and equipment available. This information is displayed on the lower Engine Indications and Crew Alerting System (EICAS) panel located in the center console.

New technology sensors include improvements in both photoelectric and ionization smoke/particle detectors and new technology thermal sensing systems capable of monitoring and establishing a thermal profile of the area where they are installed. All detectors are interfaced with the aircraft data bus and flight management computer system, providing alarm indications directly to the flight deck. The generation of a smoke/fire event signal causes the automated emergency checklist to be activated and displayed to the flight deck.

The need for additional detector coverage has been identified for the galleys, lavatory, overhead compartment (attic), conditioned air exiting the air packs, and hidden areas. The new detectors greatly reduce the potential for false alarms (a constant source of problems in existing aircraft), one detector requires a given number of sequential pulses (4 pulses, 2 seconds apart) before the alarm threshold is reached. The use of parallel detectors coupled with "and" circuit logic further reduces the potential for false alarm by providing concurrence and backup. These circuits are reconfigurable if one of the detectors fails, and will provide maintenance messages if a circuitry fault is detected, and still allow the aircraft to be dispatched. A matrix of detector types, capabilities, advantages, and disadvantages, reviewed during the course of the study, is provided as an Appendix.

Average unit costs for an installed system, which includes all nonrecurring and recurring costs based on a fleet implementation for 200 aircraft, is \$57,300 for Concept A, \$189,150 for Concept B utilizing a Schlumberger acoustic thermal detection system, and \$190,150 for Concept B incorporating a York fiber-optic thermal detection system.

Federal Aviation Administration

Aircraft Command in Emergency Situations (ACES)

Final Report

1. INTRODUCTION

The feasibility of using a computer-based system that would assist a flight crew in the direction and management of inflight fire and smoke emergencies was established through an analysis of thirteen hypothetical emergency scenarios (Reference 1). The conclusions reached in this study indicate that both the current and projected advancements in sensor, computer, and display technologies have advanced whereby a computer-based fire detection system can provide timely guidance to the flight crew in responding to inflight smoke fire emergencies. These conclusions influenced the FAA decision to implement a product definition study and develop the broad objectives for an ACES advanced smoke/fire detection system.

1.1 BACKGROUND

It can be argued, that though very infrequent, the most dangerous inflight emergency is a smoke/fire event occurring in a passenger laden aircraft. Generally the exact location and source of the smoke/fire is unknown, sometimes in a hidden area within the pressurized volume. When a fire is discovered in a hidden area, time that should be used to divert to the nearest suitable airport is often not used to its best advantage: the crew tries to determine location and source of the event. Most people, especially those not trained in fire management, do not appreciate the speed at which a fire can evolve to catastrophic intensity nor the difficulties in completely extinguishing a fire.

While commercial air travel is undoubtedly the safest mode of public transportation, it is, unfortunately, not without its tragedies. The conclusion to be drawn from recent study of accident history file is the necessity of early smoke fire detection coupled with prompt and correct action by the flight crew *in getting the airplane on the ground*. It is clear from accident and incident data that early detection of a smoke/fire event is of significant importance as is the communications/warnings of event information to the flight deck in a clear, concise, and reliable manner. These two items, early detection and prompt action, are seen to be the critical criteria in nearly all inflight fire incidents. The Varig 707 (1973), Saudi L-1011 (1980), and the Air Canada DC-9 (1983) accidents all demonstrate the tragedy that can result when a hidden fire progresses undetected and less than prompt action is taken to land at the nearest available airport.

Communications between the cabin attendants and the flight deck is critical, especially with the advent of the two-man flight crew. With a two-man flight crew the flight deck is dependent on the cabin attendants for information regarding a smoke fire event in the lavatory, galleys, overhead (attic), and passenger areas. Upon being made aware of a fire event, the flight deck will call upon the Quick Reference Handbook (QRH) to review and implement the specified airline emergency procedure. FAA studies have shown that the time required to access the QRH and specific procedures is time not spent on directly dealing with the emergency.

Major fire prevention-protection improvements have been incorporated into commercial aircraft in the decade of the 80's. These improvements, while not without great expense in some instances, have provided a net benefit to the flying public. Aircraft fire safety improvements are best seen in the Federal Aviation Regulations (FARs) which have been mandated since 1984. These rules, discussed in the next section, included: seat fire blocking layers, floor proximity lighting, smoke detectors and automatic discharge halon fire extinguishers in the lavatory, and heat release, flammability, and smoke criteria for interior materials. All of the FARs have added greatly to aircraft safety, both in preventing fire and in increasing passenger survivability should a fire occur.

This ACES study is a result of the FAA's desire to improve commercial aircraft fire safety through research and study of new technology and applications.

In March, 1989, Boeing Commercial Airplane Group completed a multi-phase FAA contract study, for "Airplanes Tests of Enhanced Smoke Venting" (Reference 2). During 1988/89 Phase 3 aircraft testing, both ground and inflight, was conducted. A Boeing owned 757-200 was used as a test platform to verify the previous Phase I Study findings on enhanced smoke venting techniques for removing smoke from a passenger aircraft cabin.

For a number of years, Boeing has been conducting Independent Research and Development (IR&D) studies on various automated cockpit concepts for implementing electronic emergency procedure checklist and expert systems that will perform various flight deck crew functions, thus reducing pilot work load. Initial applications of these Boeing IR&D efforts have been included in both the 1989/90 contract for the ACES Phase I concept development and 1990/91 Phase 2 prototype hardware demonstration.

1.1.1 FAR Requirements

Prior to 1946, there were no requirements for smoke and fire detection systems within the passenger and cargo compartments. In 1946, Civil Air Regulation (CAR) Amendment 04-1 established limits on the sizes and classes of cargo compartments and the requirement for smoke/fire detection and suppression in Class C compartments. The CAR was again amended (4b-6) in 1952 to establish the requirements for a Class D compartment. Class D compartments are required to have fire-resistant liners and the capability to extinguish a fire through oxygen depletion. The old CAR amendments resulted in FARs 25.855, 25.857, and 25.858.

As a result of a number of inflight incidents and, most specifically, the tragic loss of life following an inflight fire on an Air Canada DC-9 in 1983, numerous regulations effecting fire safety inside the pressurized volume have been adopted. Rules published since 1984 are presented in Table 1-1 below.

Table 1-1. Transport Aircraft Fire Safety Rulemaking.

Rule	Final Rule Published	Compliance Date	Parts Affected	Am'dt Number
Seat fire blocking layers	10/26/84	11/26/87	25, 29, 121	25-59
Floor proximity lighting	10/26/84	11/26/86	25, 121	25-58
Cabin fire protection	3/29/85		121	121-185
Lavatory smoke detectors		10/29/86		
Lavatory automatic fire extinguishers		4/29/87		
Halon 1211 hand extinguishers		4/29/86		
Hand extinguishers		4/29/85		
Cargo compartment fire protection	5/16/86	6/16/86	25	25-60
Cabin material flammability	7/21/86		25, 121	25-61
100/100 heat	8/25/88	8/20/88		25-66
65/65 heat, 200 smoke		8/20/90		
Crew protective breathing	6/3/87	7/6/89	121	121-193
Cargo compartment fire protection	2/17/89	3/20/91	121, 135	121-202

Source: C.P. Sarkos paper presented at International Aircraft Cabin Safety Symposium, January 22-25, 1990

Aircraft seat cushions are typically made with a polyurethane foam core that can produce lethal smoke and combustion gases. Amendment 25-59 established the seat blocking rule (FARs 25.853 (b) and 121.312 (b)) requires the use of a highly fire resistant material to encapsulate the foam core seat cushion. The blocking material delays the ignition of the seat foam core, thereby providing a more survivable environment.

As a fire burns the upper portion of the cabin is filled with hot buoyant smoke and gases. As smoke and gas continues to be generated by the fire, the smoke "ceiling" descends down to floor level. Floor proximity lighting, amendment 25-58, resulting in FARs 25.812 (e) and 121.310 (c), is the means to direct passengers to the emergency exits during the extreme moments of passenger egress.

Regulations governing fire protection in airplane lavatories and hand held fire extinguishers were greatly expanded with implementation Amendment 121-185. This regulatory activity was the result of two closely spaced incidents, June 2, 1983 at Cincinnati and June 25, 1983 at Tampa. FAR 121.308 requires that each lavatory be equipped with a smoke detector system which provides a warning to the flight attendants and/or the flight deck and that each lavatory trash receptacle be equipped with a fire extinguisher that would discharge automatically upon fire in the receptacle. FAR 121.309 addresses the need for an increase in the number of hand held fire extinguishers to be installed in passenger aircraft of 60 seats or more and requires that at least two of the extinguishers contain Halon 1211 or equivalent as extinguishing agent.

The fire protection requirements for class C and D cargo compartments were upgraded by Amendment 25-60. Class D cargo compartment volume was restricted to 1,000 cubic feet (FAR 25.857 (d)). FAR 25.855 specifies new burn through fire test criteria for C and D cargo compartment ceiling and sidewall liner panels. A Class D cargo compartment depends on oxygen starvation to control a fire. This method of fire control requires that the compartment liner material not be breached, and thus allow air to enter the compartment and "feed" the fire. Both these rules serve to upgrade the fire safety standards of Class D compartment

Amendment 25-61 upgrades the fire safety standard for cabin interiors by establishing new fire testing criteria. Amendment 25-66 refines the test criteria established by 25-61 and adds new requirements for smoke emission testing. These two amendments identify the Ohio State University rate-of-heat-release apparatus as the most suitable method for determining material qualification. Smoke emission testing is intended to minimize the impact smoke obscuration will have on emergency egress.

Amendment 121-193 requires protective breathing equipment (PBE), such as a full face mask attached to an oxygen supply, be made available to the flight attendants, in addition to the flight deck crew, to provide protection when fighting on-board fires. Three fatal accidents since 1973, the latest being the 1983 Cincinnati fire, lead to the requirements contained in this amendment. With PBE available it is conceivable that the loss of life that occurred in each of these three accidents may have been lessened. Portable PBE as required by this rule are to be located within three feet of each hand held fire extinguisher (FAR 121.337) for use by the crew in fighting the fire. Amendment 121-218 extends the compliance date from 7/6/89 as shown in Table 1-1 to 1/31/91.

Amendment 121-202 (FAR 121.314) imposes stringent burn through requirements on all Class C and D cargo compartments liners.

Part 25.858 establishes the Airworthiness Standards for cargo compartment fire detection systems and is given below in full:

- a) The detection system must provide a visual indication to the flight deck within one minute after the start of the fire.
- b) The system must be capable of detecting a fire at a temperature significantly below that at which the structural integrity of the airplane is substantially decreased.

- c) There must be means to allow the crew to check inflight, the functioning of each fire detector circuit.
- d) The effectiveness of the detection system must be shown for all approved operating configurations and conditions.

The major impact of the part 25.858 is the tightening of the respond time criteria from five minutes to one minute. This has led to the use of even more sensitive detectors, which can impact the rate of false alarms.

The above FARs coupled with increased systems reliability and years of safety design experience, has greatly improved aircraft fire safety. However, there are still improvements which can be made to provide increased, cost effective, passenger safety benefits.

1.2 PREVIOUS STUDIES

Several distinguished studies that established the groundwork and technical feasibility of advanced smoke/fire detection systems have been previously undertaken by the FAA and private companies. These studies form part of the foundation and direction which has influenced the ACES program. Namely:

Heath Tecna, Kent, WA, 1985/86 — Developed a microprocessor prototype demonstration system utilizing smoke detectors, fused links, and thermistors (IR&D) (Reference 3).

Hughes Associates, Wheaton, MD, 1987/88 — Conducted an FAA-funded state-of-the-art review of detector technology focusing on the location and magnitude of temperature changes and software required to link existing data systems (Reference 4).

Dunlap and Associates, Norwalk, CT, 1987/88 — Conducted FAA-funded technology assessment study of automated smoke/fire detection, postulating scenarios for evaluation of hypothetical ACES system (Reference 1).

1.3 PURPOSE

The purpose of the ACES contract is to develop two system configurations utilizing either a different approach or complexity, which, through analysis, will demonstrate the projected systems effectiveness in both performance and cost. The goal of each system is the same, to provide accurate and timely smoke/fire warning to the flight crew, (cabin and flight deck). Such warning will enable the fire to be controlled and procedures implemented to expedite the landing of the aircraft.

2. SCOPE

The ACES contract studied several broad areas: current and new sensor technology that would provide additional detection capability on the study aircraft; the computer interface and processing required to integrate an ACES-type system; display format and type of information to be displayed on the flight deck; and impact and improvements to crew workload as a result of integrating the recommended ACES concept.

A matrix that details the configurations and capabilities of the baseline aircraft and of the two ACES concepts is shown in Table 2-1. An assessment and analysis of the concept systems performance was accomplished using only the 757-200 (baseline) study aircraft and the scenarios previously postulated in the Dunlap and Associates technology assessment.

Table 2-1. ACES System Configurations.

	Baseline 757-200	ACES Configuration	
		Concept A	Concept B
<u>Detector Locations</u>			
Lavatory			
Ceiling - smoke	Ion-discrete	Ion-discrete	Ion-discrete
Under counter - smoke	N/A	Ion-discrete	Ion-discrete
Attic			
Smoke	N/A	Photo-pulse	Photo-analog
Thermal	N/A	N/A	Yes (1)
Air-conditioning			
Smoke	N/A	Photo-analog	Photo-analog
Cargo			
Smoke	Photo-discrete	Photo-pulse	Photo-analog
Thermal	N/A	N/A	Yes (1)
Galley			
Smoke	N/A	Ion-discrete	Ion-discrete
Lower lobe cheek			
Smoke	N/A	N/A	N/A
Thermal	N/A	N/A	Yes (1)
<u>Computers</u>			
Baseline	Yes	N/A	N/A
Baseline w/ expanded memory	N/A	Yes	N/A
New computer	N/A	N/A	Yes
<u>Flight Deck</u>			
Quick Reference Handbook	Yes	N/A	N/A
Electronic Checklist	N/A	Yes	Yes
Inflight Diversion Planner	N/A	N/A	Yes
System Synoptics	N/A	N/A	Yes
Alerting System			
Baseline	Yes	Yes	N/A
Expanded	N/A	N/A	Yes
<u>Cabin Attendant</u>			
Crew Call System	Yes	N/A	N/A
Cabin Attendant Panel	N/A	Yes	Yes

Note 1: Thermal monitoring: acoustic (Schlumberger) or fiber optic (York)

2.1 OBJECTIVES OF STUDY

Given an inflight smoke/fire emergency:

The objective of the ACES study was to develop two system concepts that would result in reducing the time required to make a decision to land the aircraft; provide accurate, timely, and complete guidance to the flight crew for their use in responding to inflight smoke/fire events; and to enhance/improve the situational awareness of the flight crew to an inflight fire.

2.2 STUDY CONSTRAINTS

For planning and control purposes, some parametric constraints were placed on the study. These parameters are given below:

- a) Smoke/fire events were restricted to those occurring in the pressurized volume; engines, control surfaces and other non-pressurized areas are not considered.
- b) The study is directed at large commercial passenger transport category aircraft only. Smaller general aviation aircraft are not considered.
- c) Only new airplanes are considered. Issues regarding fleet retrofit are not addressed.
- d) For sensors to be considered for ACES application they must be commercially available. Sensors in breadboard/R&D stage of development were not considered.
- e) Volume, weight, and maintenance considerations of ACES hardware must be adaptable to aircraft application.

Specific applications of ACES concepts were limited to the Boeing 757-200, but additional consideration was given to "combi" type aircraft, where passengers and cargo are colocated on the main deck, posing unique safety considerations.

2.3 APPLICATION OF DUNLAP SCENARIOS

The fire scenarios described in Reference 1 were prepared by Dunlap and Associates in their technology assessment and have been used as a basis for comparing the capabilities of the baseline airplane and each of the two ACES concepts. Improvements in detection time and outcome are postulations based on an experienced engineering assessment and practical first hand knowledge of the aircraft, its systems and operational procedures, changes in regulations, and the addition of new technology smoke and fire detection systems.

A summary of each of the Dunlap scenarios is discussed in Section 7.1. Figure 2-1 is a matrix tabulation of the general parameters and conditions of these scenarios.

Four specific areas were identified in the Reference 1 report where an ACES type system would contribute to significant improvements in overall aircraft safety. The areas identified, and investigated in the course of this produce definition study, are given below:

- a) Sensing – Improvements can be achieved with the implementation of newer, increased sensing capability smoke/fire detectors and additional selected locations.
- b) Alerting – By integrating the sensor and detector systems into the aircraft avionics data buses, the flight deck can receive the alerts the instant they are detected.
- c) Crew response – A significant amount of time can be saved with the automation of the emergency procedures checklist, which, once activated by an alert, would be instantly available to the flight deck crew for implementation.
- d) Crew decision making – Once an alert is sounded and the emergency checklist is implemented, the flight crew will be able to consult the Boeing-developed "NEXPERT" system for assistance in diverting to the closest suitable airport.

Upon review and study of the Reference 1 report the above four areas were found to be major links in the smoke/fire detection/response chain required to accomplish the primary goal of ACES: land the aircraft and evacuate the passengers as quickly as possible. While these areas are of importance, they were not used as study constraints.



Scenario	Type of Indication	Indication Speed	Identified Location	Discern Smoke/Fire
Scenario #1 Wide Body 3 Engine 3 Crew	Horn and Light (Master Warning)	Immediately Upon Detection; 7-15 minutes After Ignition	Aft Cargo	Only Smoke Detectors
Scenario #2 Narrow body 2 Engine 2 Crew	Interphone Message	Immediately Upon Detection; But May Have Been 14 minutes After Ignition	Aft Lavatory	Attendant Identified Smoke and Fire
Scenario #3 Wide Body 4 Engine 2 Crew	Horn and Light (Master Warning)	Immediately Upon Detection; No Ignition	Aft Baggage	Only Smoke Detectors
Scenario #4 Narrow body 3 Engine 2 Crew	Horn and Light (Master Warning)	Immediately Upon Detection; No Ignition	Aft Lavatory	Only Smoke Detectors
Scenario #5 Wide Body 3 Engine 2 Crew	Interphone Message Horn and Light (Master Warning)	Immediately Upon Detection; Several Minutes After Ignition	Center Lavatory	Attendant Identified Smoke
Scenario #6 Wide Body 4 Engine 3 Crew	Interphone Message	Several seconds; Overheat Occured Before Sensing	Ceiling Light Ballast	Passenger Identified Odor Only (No Smoke)
Scenario #7 Narrow body 2 Engine 2 Crew	Horn and Light (Master Warning)	Immediately Upon Detection; Several Seconds After Smoke Started	Avionics Bay	Only Smoke Detectors
Scenario #8 Wide Body 2 Engine 2 Crew	Cabin Attendant	1 Minute; 5 Minutes After Ignition	Forward Closet	Attendant Observed Smoke

Figure 2.3-1. Dunlap Scenario Evaluation

(2)

OPS Manual-Contains Specific
 Procedure for Fire in
 Identified Location
 Flight Crew Procedures

Cabin Crew Procedures

	Indication True/ False	Available	Time to Locate	Followed	Available	Followed
	True	Yes	4 Minutes	Yes, But Did Not Expedite Return	No	N/A
Identified	True	No	N/A	N/A	Yes	Yes
Fire	False	Yes	Immediate	Yes	No	N/A
	False	No	N/A	N/A	Yes	Yes
Identified	True	DC10 - Yes L1011 - No	Immediate N/A	Yes, But Diverted N/A	Yes	Yes
Identified	True	No	N/A	N/A	Yes	Yes
	True	Yes	Several Seconds	Yes	N/A	N/A
Identified	True	No	N/A	N/A	Yes	Yes

Scenario	Type of Indication	Indication Speed	Identified Location	Discern Smoke/Fire	Indic True/
Scenario #9 Narrow body 2 Engine 2 Crew	Interphone Message	1 Minute After Smoke Was Observed	Cabin Smoke	Attendant Observed Smoke	T
Scenario #10 Wide Body 3 Engine 3 Crew	Horn and Light (Galley Smoke)	Immediately Upon Detection; But May Have been 26 Minutes After Ignition	Lower Lobe Galley	Smoke Detector	T
Scenario #11 Narrow body 2 Engine 2 Crew	Interphone Message	Immediately Upon Sensing; 12 Minutes After Smoke Started	Galley Oven	Attendant Observed Smoke	T
Scenario #12 Narrow body 4 Engine 3 Crew	Crew Observation	Immediately Upon Observing; 34 Minutes After Ignition	Avionics Bay	Crew Observed Smoke	False Carg
Scenario #13 Wide Body 2 Engine 2 Crew	Interphone Message	Immediately Upon Observing; 1 Minute After Ignition	Passenger Cabin	Attendant Observed Smoke and Fire	T

Figure 2.3-1. Dunlap Scenario Evaluation (Continued)

2

**OPS Manual Contains Specific
Procedure for Fire in
Identified Location
Flight Crew Procedures**

Cabin Crew Procedures

Indication True/ False	Available	Time to Locate	Followed	Available	Followed
True	Yes	4 Minutes	Yes, Crew Acted Rashly in Engine Shutdown	N/A	N/A
True	Yes	30 Seconds	Yes, But Delayed 35 Minutes to Declare Emergency	Yes	Yes
True	No	N/A	N/A	Yes	Yes
False was a Cargo Fire	Yes	2-3 Minutes	Yes, Identified Wrong Source and Used Wrong Procedure	N/A	N/A
True	No	N/A	N/A	Yes	Yes

One possible scenario not postulated in the Dunlap report pertains to smoke/fire emergencies that occurs in a combi configuration airplane (Class B cargo compartment) when no alternate airport nearby. This scenario will be addressed, in full, in Section 7.1.14.

3. BASELINE AIRCRAFT

The Boeing 757-200 airplane was selected by the ACES study team as the baseline aircraft for the purposes of this study. A 757-200 configuration with mixed class (first and economy) passenger seating, four lavatories, and three galleys located forward, mid and aft is to be used for this product definition study. The general arrangement, principal characteristics, and body cross section of the 757 aircraft is presented in Appendix B.

The 757 is also manufactured as combi and package freighter models, thus providing for a full compliment of airplane configurations to be studied.

3.1 GENERAL DESCRIPTION

The 757, passenger configuration, was studied to develop a full range of aircraft requirements for the configuration and evaluation of an ACES system. The 757 afforded many advantages in the study and definition of the two ACES concepts: a modern airplane with a state-of-the-art flight deck, Figure 3-1; a two-man flight deck crew; a fire detection and suppression system in the forward and aft cargo compartments, Figure 3-2. The 757 is also equipped with engine, auxiliary power unit (APU), and wheelwell fire/overheat warning systems, these systems fall outside the pressurized volume and are not addressed in the study.

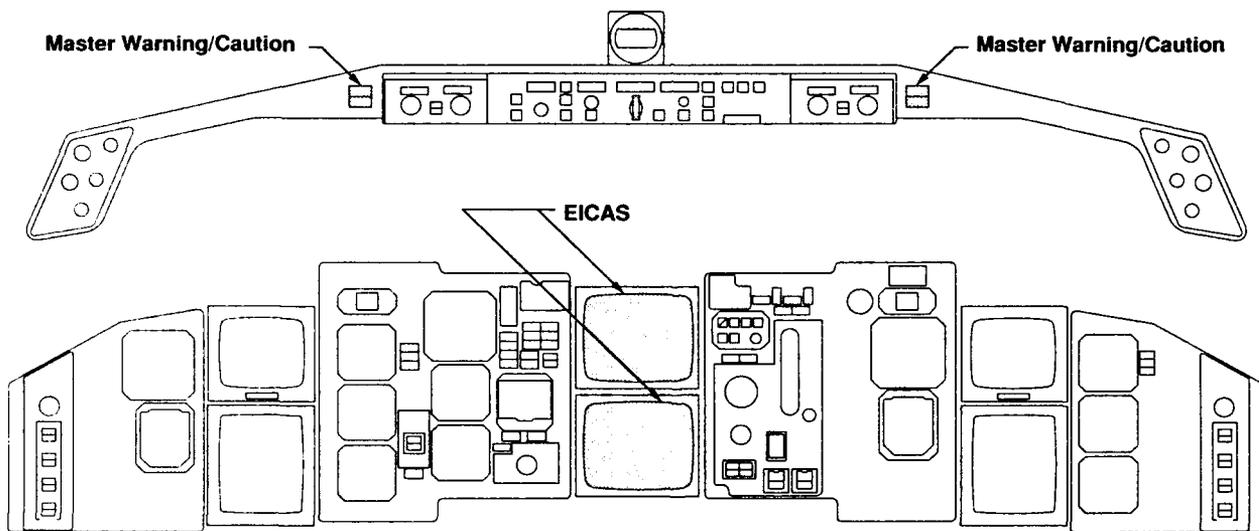

Figure 3-1. 757-200 Flight Deck EICAS Displays.

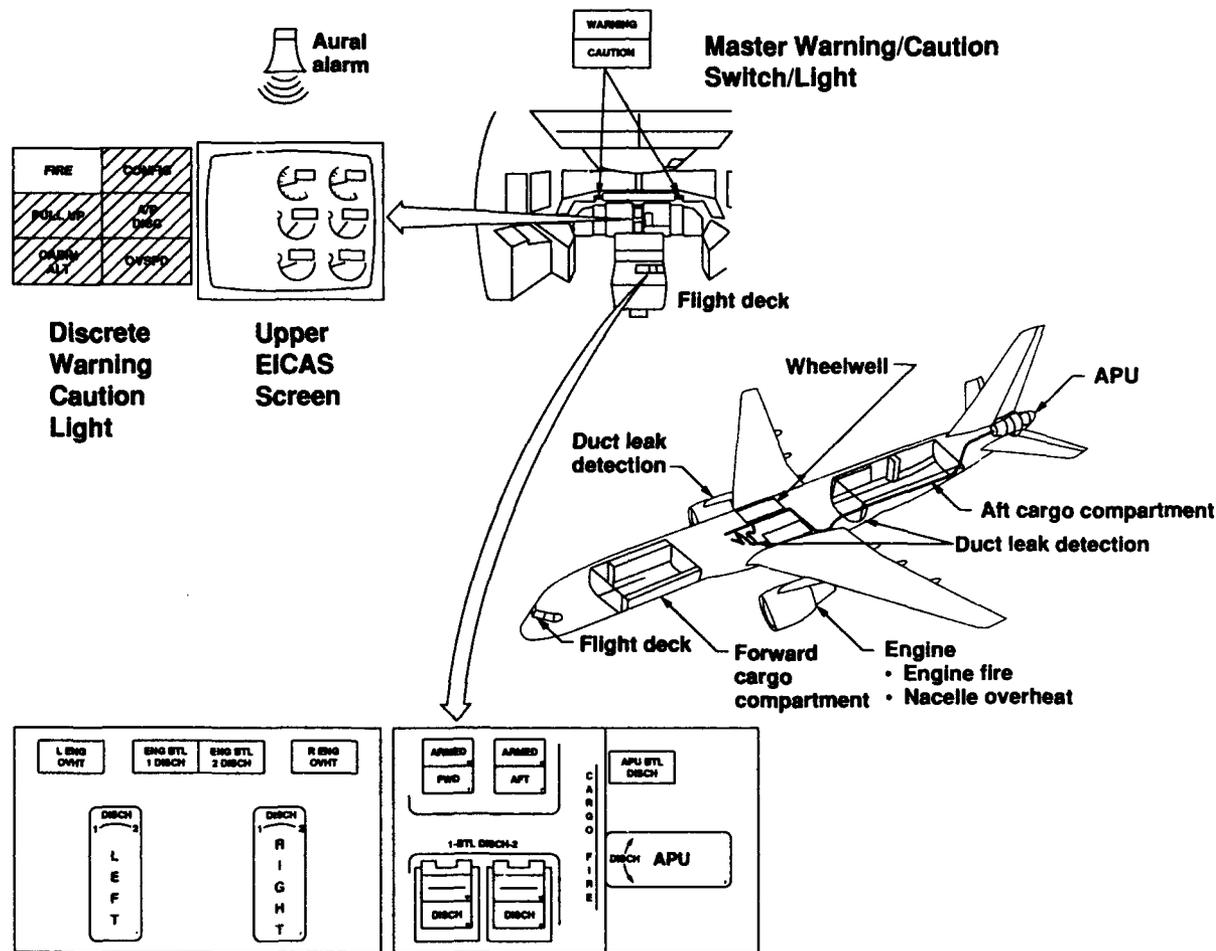

Figure 3-2. 757-200 Fire Protection Systems.

To maintain cabin and flight deck air temperature, air quality, and cabin pressurization, the 757 utilizes a centralized, two pack, Environmental Control System (ECS). The packs condition (cool) engine bleed air, that is then mixed (in the mix manifold) with recirculated cabin air and given final temperature regulation by the use of hot trim air. This air is then delivered to the passenger cabin through the air distribution system. During normal flight the ratio of fresh air to recirculated air is approximately 1 to 1. The flight deck is serviced separately from the passenger cabin and receives only fresh conditioned air, no recirculated air. Lavatory and galley exhaust air is routed directly to the aft lower lobe area of the airplane where it is vented overboard through the outflow valve. Some of the air exiting from the flight deck and the passenger cabin is used to control the thermal environment of the Electronic Equipment (E/E) bay and cargo compartments. Air which has been circulated through the E/E bay is then returned to the mix manifold to be reconditioned with fresh conditioned air.

The ECS/air distribution systems provide several potential pathways for smoke to enter the occupied areas of the airplane. Smoke could be detected in the contaminated bleed air from one of the engines, the APU, a faulty pack, or the E/E bay. The E/E bay is equipped with smoke detectors that monitor the air both as it enters and exits the E/E bay, if smoke is detected the E/E exhaust air is vented overboard. There are currently no procedures on the 757 to determine if a pack, engine, or APU is the source of a smoke problem, nor is there a procedure which engine or pack (right or left) is the source of the smoke without some trial and error tests, discussed later in this report.

3.2 BASELINE DETECTOR TYPES

The 757-200 passenger airplane employs two sensing technologies, ionization and photoelectric, for monitoring specific areas within the pressurized hull for smoke/fire events. Ionization sensors detect invisible particles (less than $0.3\ \mu\text{m}$) and photoelectric sensors detect visible particles (greater than $0.3\ \mu\text{m}$) such as smoke. Each of these technologies, as used in the 757, are discussed in the following paragraphs.

3.2.1 Ionization

The ionization detector used on the 757 and other airplanes in the Boeing family (737,747,767), is a dual-chamber type manufactured by Jamco, P/N PU90-499R3 (Reference 5). Air entering each of the chambers passes over an alpha radiation source, Am241. The ionized air passes between two charge plates, allowing a current to flow. One chamber is used as a reference and is only partially open to the environment through a small pin hole. This secondary, (reference) chamber provides for compensation due to fluctuations in power supply as well as changes in temperature, pressure, and humidity. The primary chamber is open to the environment and any particles in the air causes the current flow between the two charged plates to be altered. The current flow in the primary chamber is then compared to the current flow of the reference chamber. When the two chambers become sufficiently "unbalanced," an alarm signal is generated. A dual-chamber configuration is design to reduce the incidence of false alarms.

3.2.2 Photoelectric

The photoelectric smoke detector used on the 757 and other airplanes in the Boeing family (737,747,767), is manufactured by Autronics, P/N 2156-204 (Reference 6). The detector consists of a photocell, a pilot lamp, light trap, and a test lamp, encased in a light-proof chamber, Figure 3-3.

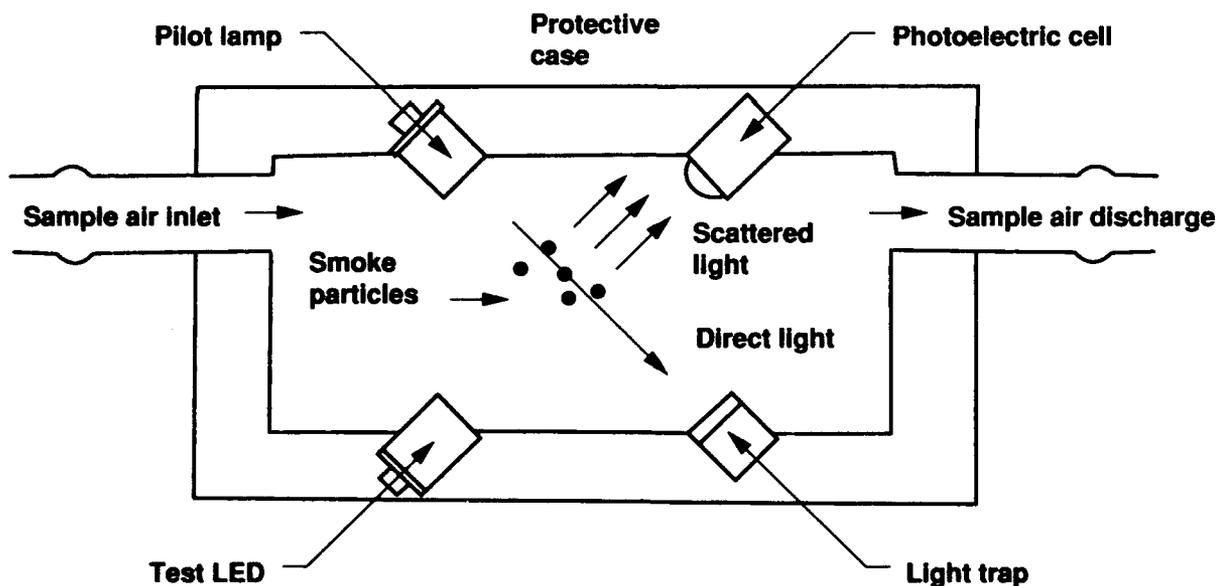

Figure 3-3. Autronics Photoelectric Smoke Detector.

The detector unit directs a small focused beam of light, from the pilot lamp, across the chamber to a non-reflective surface (light trap) at the opposite side of the chamber. In clear air, without particles, there is little or no scattering of the pilot light beam and thus no light reaches the photocell. With the absence of light, the cell is in a highly resistive state. When particles greater than $0.3\ \mu\text{m}$ (visible particles) enter the chamber, light is scattered with some reaching the photocell. Light striking the photocell causes a decrease in resistance. When the resistance drops to a calibrated level, equivalent to the light transmissibility to falling below 92% to 85% (measured over one foot), an alarm signal is sent from the detector to the Automatic Fire/Overheat Logic Test System (AFOLTS) card, (discussed in Section 3.3.1), for interpretation and transmit-

tal to the flight deck. Testing of the photocell is accomplished by the use of the test LED (light emitting diode) that is focused on the photocell.

3.3 LOCATIONS MONITORED

The all passenger configuration 757-200 has smoke/fire protection in the forward and aft Class C cargo compartments, all lavatories, and the forward E/E bay. Halon 1301 is used for fire suppression in the cargo compartments, the command for discharging the halon is initiated from the flight deck. Small halon bottles are installed in each of the lavatory waste bins. The bottles have a thermal plug, that when exposed to elevated temperatures melts, releasing the halon agent. The passenger cabin is equipped with 3 to 4 hand held fire extinguishers, the number depends upon passenger seating configuration. Of these hand held fire extinguishers at least 2 must contain Halon 1211 or an equivalent agent.

A block diagram of the existing smoke/fire system, showing detector and suppression locations, maintenance message capability, and flight attendant communications, is given in Figure 3-4. Table 3-1 gives the component costs of the 757 smoke/fire detection system.

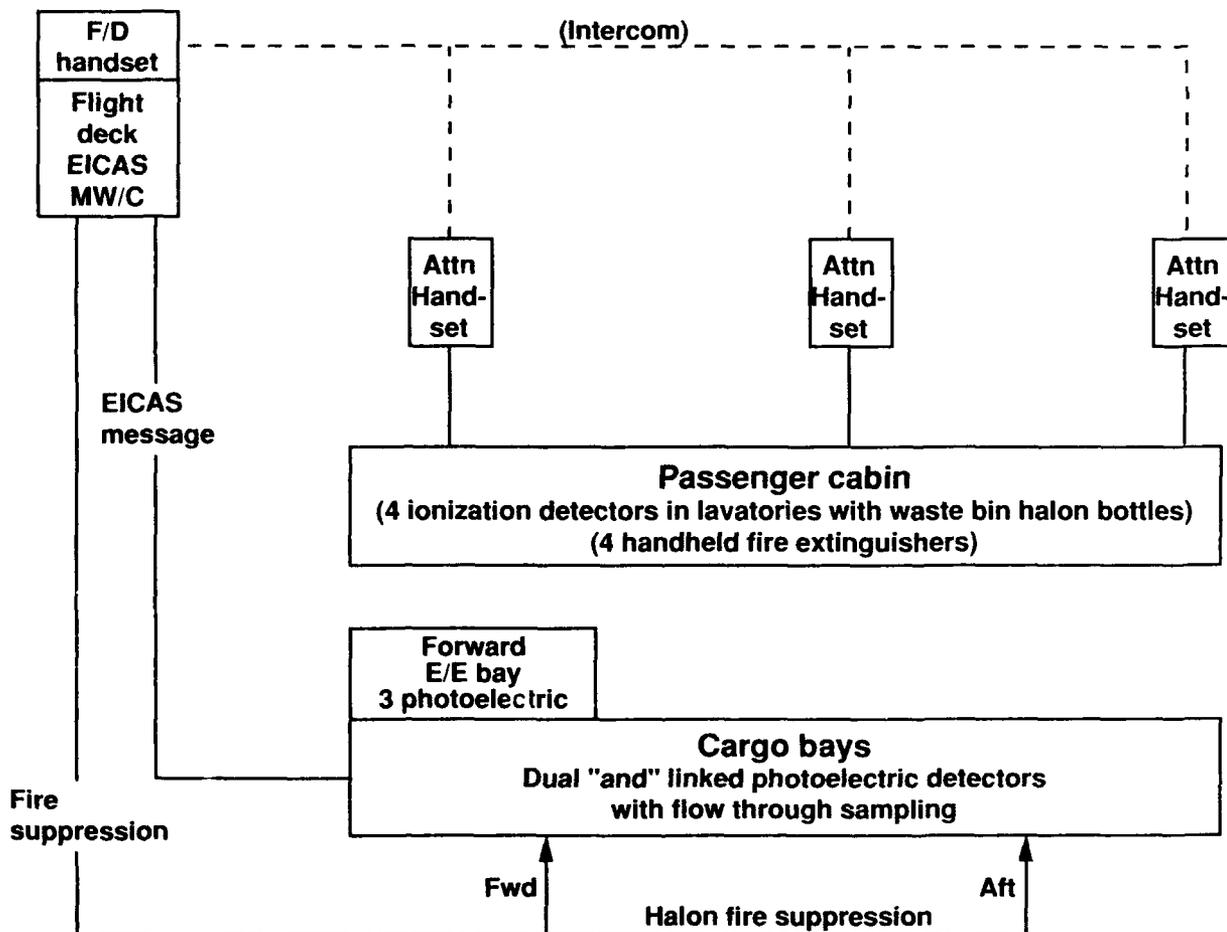

Figure 3-4. Existing 757-200 Fuselage Fire Protection System.

Table 3-1. Baseline 757-200 Component Costs.

Locations Monitored	Units	Unit Cost	Cost	Type- Manufacturer	Part No.
Cargo					
Fwd (1)	2	\$788	\$1,576	Photoelectric - Autronics	2156-204
Aft (1)	2	\$788	\$1,576	Photoelectric - Autronics	2156-204
Lavatory					
Celling	4	\$225	\$900	Ionization - Jamco	PU90-499R3
Forward E/E bay					
Supply air (1)	2	\$788	\$1,576	Photoelectric - Autronics	2156-204
Exhaust air	1	\$788	\$788	Photoelectric - Autronics	2156-204
Total Cost	11		\$6,416		

Note 1: Installed as pairs with "and" logic

3.3.1 Cargo Compartments

The 757 forward and aft lower lobe cargo compartments are classified as Class C compartments, as established in FAR 25.855. Each compartment is equipped with an independent photoelectric smoke detection system. The two compartments share a Halon 1301 fire suppression system. The cargo detection and suppression systems are shown schematically in Figure 3-5.

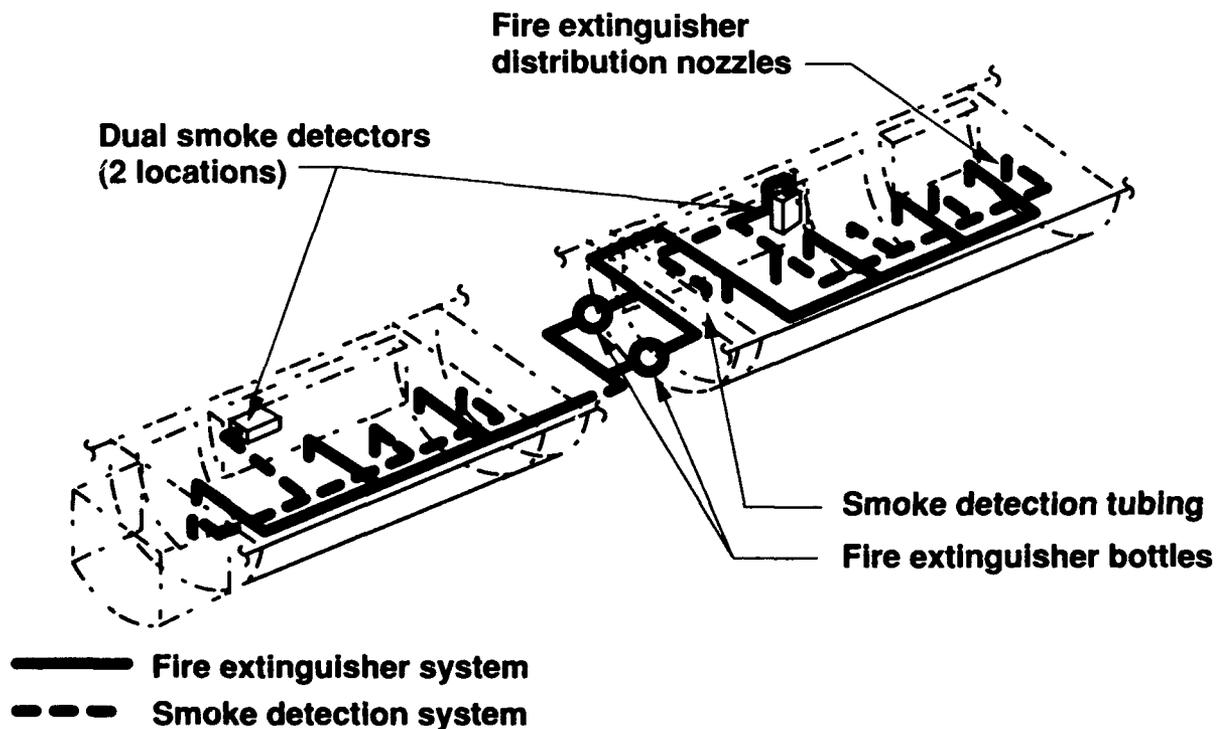

Figure 3-5. 757-200 Cargo Compartment Fire Protection.

Each of the compartments detection systems consists of dual "and" linked Autronics photoelectric smoke detectors, two vacuum source blowers, a plenum, a pressure switch, air sampling ducting, and electrical controls, Figure 3-6. Air from the cargo compartment is pulled through air sampling ports located in the compartment ceiling. (The aft compartment has 5 sampling ports while the forward compartment has 4). The 5 samples from the aft cargo compartment are mixed together (diluting the air from each port by 80%) and routed to the detector unit which is located just inside the cargo compartment door. The air is then divided and drawn through each of the dual linked photoelectric detectors.

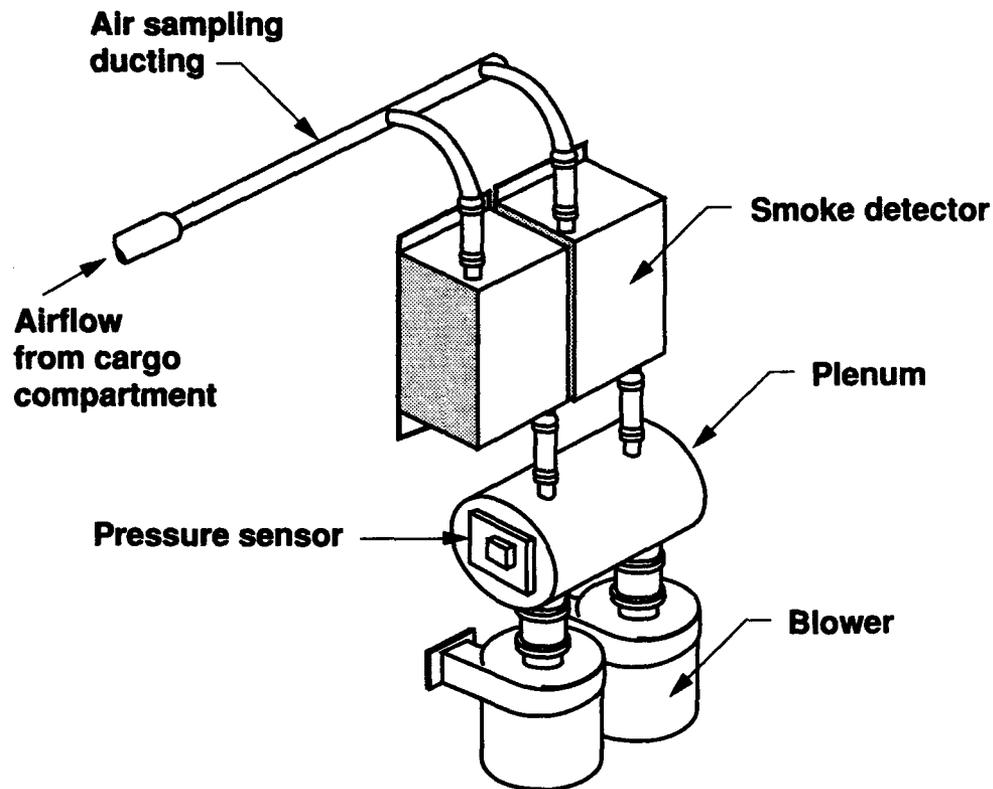

Figure 3-6. 757-200 Cargo Compartment Smoke Detector Installation.

Redundant vacuum blowers, connected through a common plenum, provide the means to pull the air through the system. If a blower should fail the pressure switch in the plenum actuates, bringing the second blower on-line. In addition, the trip causes a maintenance message to be generated and stored on the maintenance computer.

Each of the dual-loop smoke detection systems continuously monitors the air samples from the respective cargo compartments for the presence of smoke, the parameter used to determine a fire condition. If smoke is detected in a compartment by either one or both of the detectors (depending on system status), the flight deck crew is notified by both visual and audible warning devices. These include the master warning light, fire warning bell, illuminated cargo compartment fire selector switches, and the Engine Indication and Crew Alerting System (EICAS) displays.

The AFOLTS is the detection system electronic logic card that contains two functionally isolated circuits. Each circuit is connected to the dual-loop detection system. The function of each circuit is to monitor the inputs from the detectors and provide the appropriate output alarms and status signals, all based upon a specific set of Boolean equations. The AFOLTS card contains a test circuit that is activated automatically upon initial power-up or in response to a manual push-to-test button located on the flight deck.

The dual smoke detector systems of the forward and aft cargo compartments are normally operated in an "and" logic configuration. For "and" configuration, inputs from each detector is required before AFOLTS will initiate a fire warning to the flight deck. In the event that one loop (detector) is found inoperable, the system will reconfigure to single-loop operation automatically. In single-loop operation, AFLOTS requires only input from one loop (detector) to send an alarm to the flight deck.

Power to the dual detectors and AFOLTS is from the right 28V dc battery bus via three separate circuit breakers. The 28V dc battery bus provides the ability to accomplish system preflight testing concurrent with the engine fire detection test. The power circuitry is configured to ensure the continuous operation of the system. Should a failure occur in one of the redundant power sources, the AFLOTS card and detectors will remain operational with power supplied by the remaining power source.

3.3.2 Lavatory

Each standard equipment 757 lavatory is furnished with a Jamco (P/N PU90-499R3) ionization smoke detector and a automatic discharge halon fire suppression bottle located in the waste paper disposal bin, in compliance with FAR 121.855.

The ionization smoke detector, shown in Figure 3-7, is a ceiling-mounted, self contained dual chamber unit that operates on free convection principle, that is, there is no mechanical means used to move air to the detector. When sufficient products of combustion enter the primary (open) chamber an unbalance is created between the two chambers and an alarm is generated. The alarm is an audio warning sounded from the unit's built-in alarm horn. In addition, the unit's red alarm light flashes. A customer option is available that provides for the transmission of this signal to the flight deck as well.

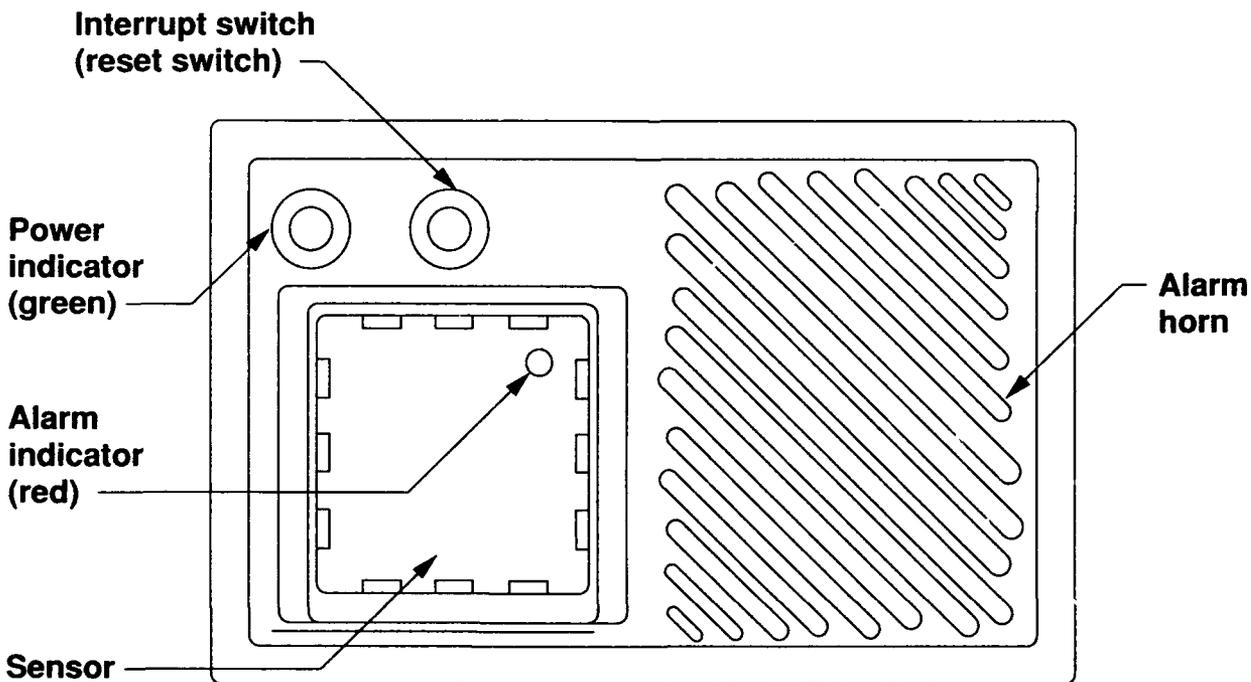

Figure 3-7. Lavatory Ionization Smoke Detector.

The Jamco unit has a green indicator light that confirms the unit is receiving power from a 28V dc battery bus. There are no provisions or requirements for the unit to be tested from the flight deck. When a smoke detector is tested, and found to be inoperable, the lavatory is secured (closed), allowing the flight to continue.

3.3.3 Electronics Equipment Bay

The forward electronic equipment (E/E) bay smoke detection system employs three photoelectric smoke detectors, manufactured by Autronics. These detectors are the light-scattering type, previously shown in Figure 3-3, the same type as used in the cargo compartment, discussed in Section 3.3.1.

The E/E bay smoke detection system, Figure 3-8, contains two smoke detection circuits – supply duct and exhaust duct. Smoke detection for the supply duct uses two photoelectric detectors, while the exhaust duct has a single photoelectric detector. The detection of smoke by either unit will illuminate the smoke light on the pilot's overhead panel. An EICAS display will provide a message indicating in which duct the smoke has been detected. During cruise condition, smoke detection in either duct causes the recirculation fans, left and right, to be commanded off, the air-conditioning to be put into high-flow mode, and the E/E Bay exhaust valve to be latched in the open position. This serves to vent the smoke overboard and switches incoming cabin air to 100% fresh air (no recirculated air). Equipment cooling requirements are maintained by the airflow generated by the pressure differential across the exhaust vent.

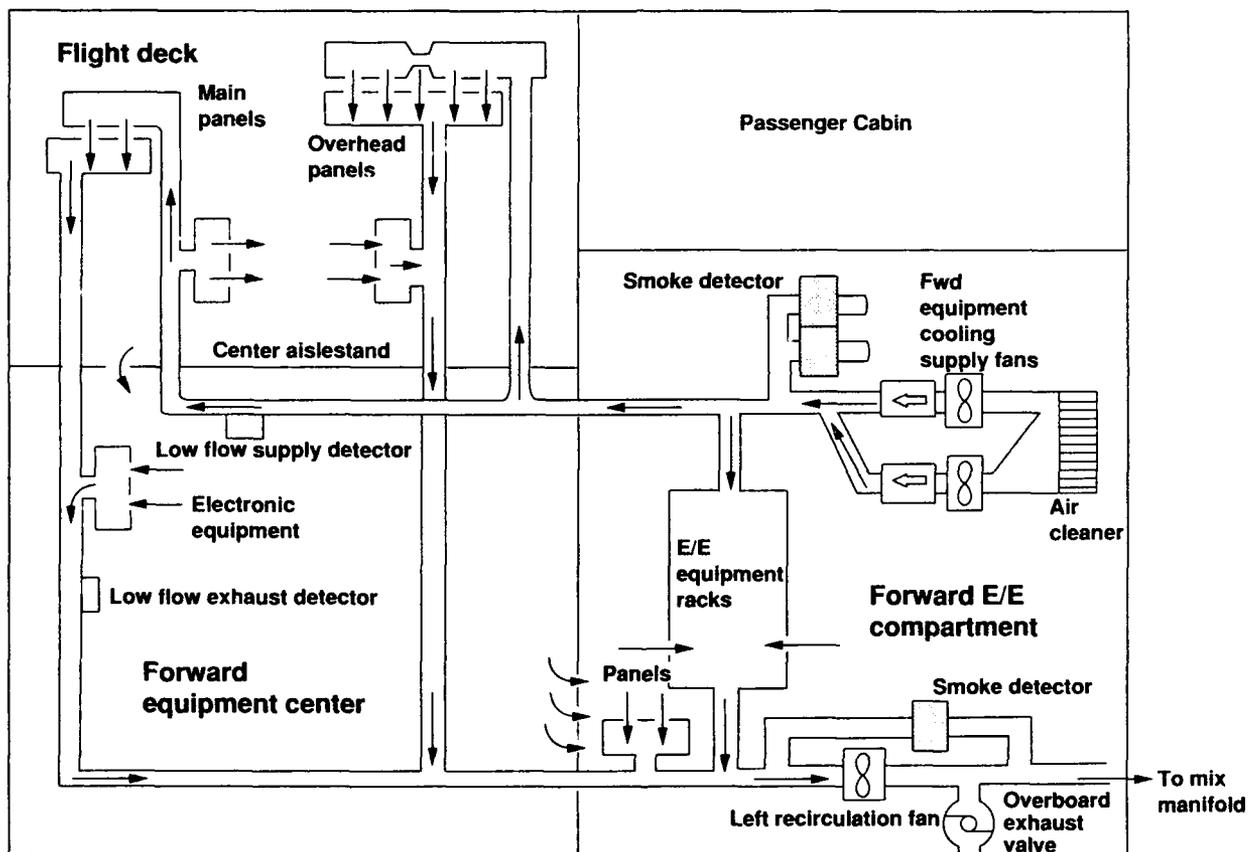

Figure 3-8. Equipment Cooling, Ventilation Systems, and Smoke Detectors.

The supply circuit uses "and" logic for detecting smoke. However, the supply system will reconfigure to "or" logic if one detector is found to be faulty during system test. A system check of both circuits is automatically performed upon engine shutdown, with any maintenance messages generated displayed on EICAS. Manual push-to-test switches are provided on the flight deck, located on panel P61, allowing the system to be tested inflight.

The aft E/E bay of 757 airplanes delivered after April 1986 do not have smoke detection units. The detector was removed when testing showed that smoke exhausting the aft E/E bay will not infiltrate into the recirculation system and enter the passenger cabin. Air from the aft E/E bay goes into the lavatory/galley exhaust vent system where it is routed to the outflow valve and overboard.

3.4 SYSTEM REQUIREMENTS

The design of the smoke/fire detection systems must be safe, reliable, and have no adverse impact on the functioning of other aircraft components.

All components are required to meet or exceed rigorous standards established by Boeing and the Federal Aviation Administration. Standards for flight quality hardware has evolved from extensive industry/military operating experience and testing. Standards for the 757 are specified for each system through a Specification Control Drawing and include performance test parameters such as altitude, humidity, temperature, power, electromagnetic interference (EMI), salt, fog, fungus, dust, acceleration loads, vibration loads, and other parameters that may be unique to a given system.

3.4.1 FAR Compliance

The 757, as certified, meets all applicable Federal Aviation Regulations as proscribed in Parts 25 and 121. Sections of greatest significance, as regards fire protection safety are addressed in Section 1.1.1

3.4.2 False Alarm Protection

False alarm protection is of paramount importance when designing and configuring a smoke/fire detection system. The 757 incorporates several features to reduce the occurrence of false alarms.

Ionization detectors installed in the lavatories use a dual-chamber configuration to protect against false alarms, and are discussed in Section 3.2.1. and 3.3.2. Ionization detectors trigger in the presence of invisible (less than 0.3 μm) particles. While this sensitivity may not be practical for all areas of the airplane, in areas with easy access such as the lavatories, a high level of sensitivity is judged to be warranted.

Photoelectric detectors, which monitor the cargo compartments and the E/E bay, protect against false alarm by use of dual detectors linked with "and" logic. While not foolproof, such a configuration requires that both sensors detect a certain smoke level (85% - 92% transmissibility over 1 foot) before an alarm is relayed to the flight deck. Additional false alarm protection is provided by the fact that photoelectric detectors are not, inherently, as sensitive as the ionization type. The photoelectric sensors react to visible particles (greater than 0.3 μm) whereas an ionization detector responds to invisible particles. In areas where visual inspection is not feasible, such as the lower lobe cargo compartment and E/E bay, a reduction in sensitivity is balanced by reduction in false alarms.

3.4.3 System Failure Analysis

The lower lobe smoke/fire system was analyzed, component by component, to determine the effects of various failures in the functioning of the overall system. The failure analysis for the 757-200 found that it is "extremely improbable that any failure will prevent the continued safe flight and landing of the airplane or the ability of the crew to cope with adverse operating conditions" (Reference 7, page 79).

3.4.4 Sensor Output/Interface

Sensor output is typically a 28V dc signal to a central electronic processing unit that routes the warning signals to the appropriate systems. The sensor outputs and interfaces in the 757 master warning/caution system are shown in Figure 3-9. The Engine Indicating and Crew Alerting System (EICAS) develops the alerting messages, lights, and tones from these signals. This system interfaces with two of the primary flight displays, referred to as the "upper and lower EICAS displays."

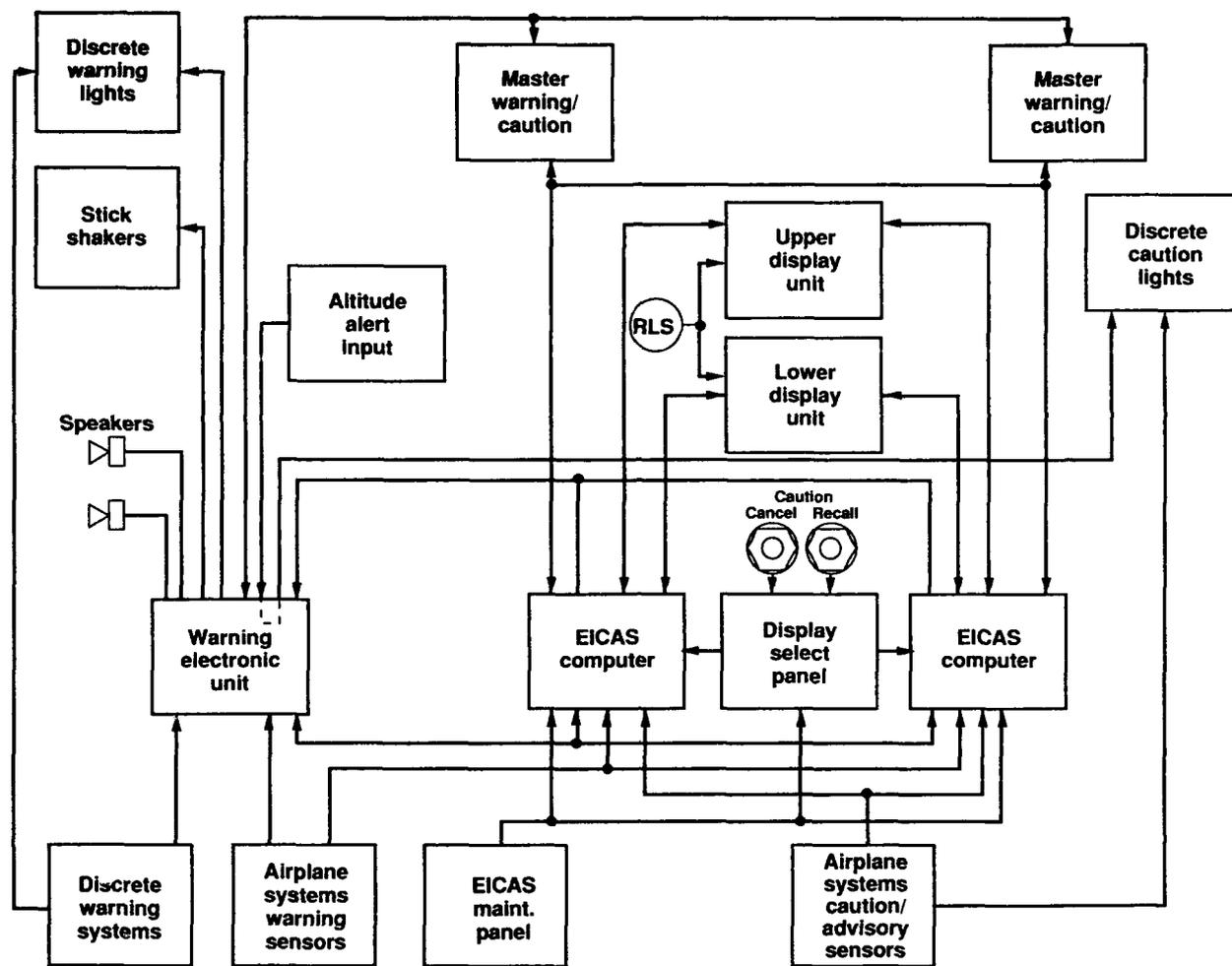

* RLS—Remote light sensor

Figure 3-9. Sensor Outputs to the Caution and Warning System.

3.4.5 Built-in Test (BIT)

The smoke/fire systems on the 757 have press-to-test capabilities that enables locating faulty and/or failed system components. System functional tests can be initiated from the flight deck allowing systems to be evaluated on the ground or inflight. System tests occur automatically at power-up for the cargo compartment and on engine shutdown for the E/E bay. A fault identified during a system test causes the system to reconfigure automatically and appropriate maintenance messages are sent and displayed/stored on EICAS.

3.5 FLIGHT DECK CONFIGURATION

The current 757 flight deck configuration and associated alerting system was used as the baseline for development of both Concepts A and B. The 757 alerting system is illustrated in Figure 3-1. For demonstration and concept development, a PC-based simulation of the EICAS displays and alerting system has been adopted and is discussed in detail in Sections 4.4, 5.5 and 6.5.

The same flight deck hardware configuration is recommended for both ACES concepts. This configuration will provide for: a) smoke/fire detector signal processing; b) generation of various alerts; c) flight deck alerting sequence; d) bringing up and performing the appropriate electronic checklist; e) bringing up and operating an inflight diversion planner; and f) calling up various synoptic displays.

3.5.1 Alerting Philosophy

The alerting system design incorporated on the 757-200 is consistent with the philosophy of alerting and alert urgency levels currently used on other Boeing aircraft and by most of the airline industry.

All alerts originating from smoke/fire detection sensors, or from associated status monitoring subsystems, are categorized into alert levels defined by the integrated alerting criteria adopted for the 757-200 and all similar aircraft. The alert levels and their criteria are summarized in Table 3-2. These alert criteria, as presented in the Boeing 757-200 Operating Manual, are standardized throughout the industry. The three primary categories of advisories, cautions, and warnings provide for differential response urgencies and procedures, while keeping the number of alert levels to an easily understood and recognized set.

Table 3-2. Alerting Categorization.

Condition	Criteria
Warning	Indicates operational or system conditions that require prompt corrective action. They are the most urgent type of alert. A cargo compartment fire is a typical warning.
Caution	Indicates operational or system conditions that require timely corrective action. They are less urgent than warnings. An engine overheat is a typical caution.
Advisory	Indicates operational or system conditions that require corrective action on a time available basis. Advisories are the least urgent type of crew alert. A yaw damper fault is a typical advisory.

3.5.2 Current 757-200 Alerting Components

The basic alert system components on the flight deck of the 757-200 are shown in Figure 3-10. The Master Warning/Caution switch-lights are the initial source of crew alerting, with either the "Warning" segment (in red), or the "Caution" segment (in amber), illuminating respectively for warning or caution alerts. At the same time, an aural tone is sounded. A "fire bell" is used for fire alerts, while for other warning-level alerts, either a siren or a warbler tone is sounded. A "beeper" sound is used for caution level alerts and no alerting tone is used for advisories.

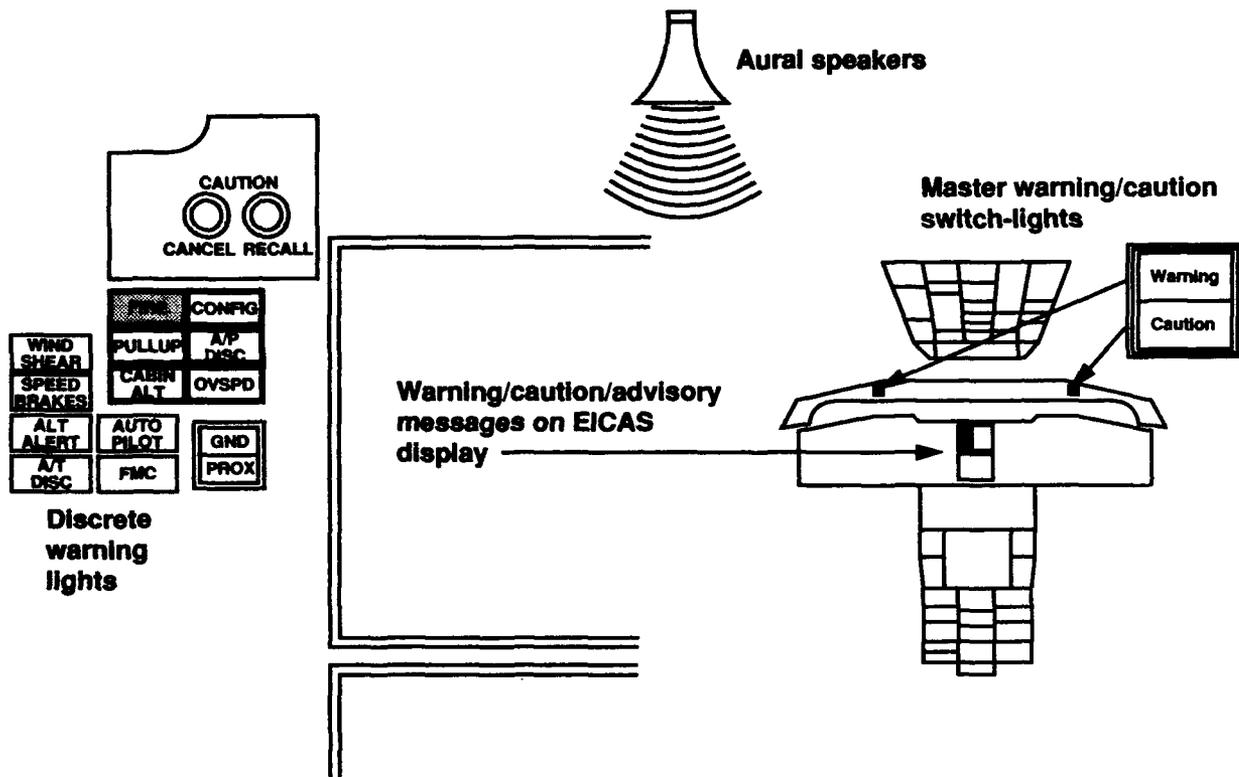

Figure 3-10. Central Crew Alerting System.

A fire warning triggers a discrete light (red), located on the front panel beside the upper EICAS display, and will light up an associated subsystem light for the affected subsystem. Currently, discrete lights are not provided for all caution and advisory level alerts. However, there may be subsystem lights that illuminate, usually in proximity or coexistent with switches that are activated in the crew's response to the alert.

Finally, for all warnings, cautions, and advisories, a message is displayed on the left half of the upper EICAS display identifying the subsystem and the source of the problem, e.g., "FWD CARGO FIRE." This message is red for warnings and amber for cautions and advisories, with the line for advisories indented one space. The results of a research study (Reference 8) recommends that a color other than amber (perhaps cyan) be used to color the advisory messages, with no indentation. Table 3-3 describes some of the relevant features of this alerting concept.

Table 3-3. Alerting System Categorization.

Condition	Criteria	Alert System Characteristics		
		Visual	Aural	Tactile
Warning	Emergency operational or aircraft system conditions that require immediate corrective or compensatory crew action	Master visual (red) plus centrally located alphanumeric readout (red)	Unique attention-getting warning sound plus voice*	Stick shaker (if required)
Caution	Abnormal operational or aircraft system conditions that require immediate crew awareness and require prompt corrective or compensatory crew action	Master visual (amber) plus centrally located alphanumeric readout (amber)	Unique attention-getting caution sound plus voice*	None
Advisory	Operational or aircraft system conditions that require crew awareness and may require crew action	Centrally located alphanumeric readout (unique color)	Unique attention-getting advisory sound	None

* Voice is pilot selectable

3.5.3 Crew Procedures

On the flight deck, warning-level alerts require an immediate response by the crew, and the established sequence involves the following steps: a) the master visual warning indicator light illuminates red, with a "WARNING" legend, and the corresponding aural alerting tone sounds; b) crew response under the 757-200 alerting configuration initially consists of a crewmember depressing the Master Warning/Caution switch-light that inhibits the fire bell and extinguishes the warning light; c) the crewmember then looks to the alert section of the upper EICAS display to determine the nature of the problem, the affected system or component, and its location; d) from this information, the crewmember performs the procedures from memory or identifies the correct checklist, and goes to the QRH to find the checklist; e) the crewmember reviews the appropriate steps that should be taken as covered in the non-normal procedures (checklist) for the particular alert; and f) the checklist steps are performed by the crewmembers. The decision to perform the checklist is made by the captain. Items that involve control of the aircraft are usually performed by the pilot flying, while those involving aircraft systems are usually performed by the pilot not flying.

3.5.4 Flight Deck – Cabin Attendant Communications

Communications between the cabin attendant stations and the flight deck on current 757-200's are established using the "Crew Call System." This system uses call switches in each handset in the passenger cabin and flight deck to select the call-to area, Figure 3-11. A call to the flight deck using the "PILOT" call switch sounds a flight deck chime and illuminates either the "FWD", "MID", or "AFT" call light, as appropriate on the pilots' overhead call panel.

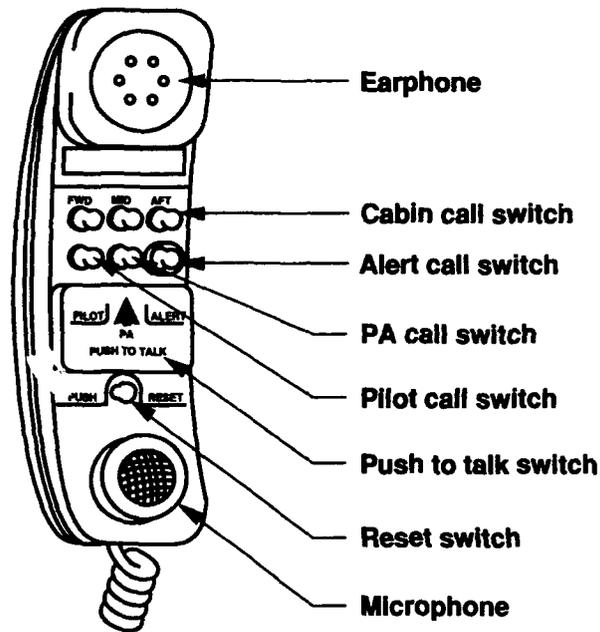

Figure 3-11. Communications Handset.

For urgent communications, pressing the red "ALERT" call switch produces an attention-getting chime on the flight deck and illuminates the pilots "ALERT" call light. In addition, a hi/lo chime sounds three times over the PA system and the pink master call lights at each flight attendant station flash. Subsequent voice communications are conducted over the handset.

The flight crew can use the system to call the cabin attendants, which results in: a) illumination of the pink master call light at the attendant station called; and b) sounding of a hi/lo chime over the passenger address system. The pink light is extinguished when the handset is lifted from its stowage position, or can also be extinguished by pressing the "RESET" switch on the handset. Calls can also be made between attendant stations. An improved cabin attendant panel for Concepts A and B is discussed in detail in Section 4.4.2.3.

3.6 AIRBUS DETECTION SYSTEM

In addition to the baseline smoke and fire detection systems used on the Boeing 757 and other similar airplanes, the detection systems used on another advanced aircraft such as the Airbus A320 were also examined. The following descriptions are based upon technical training manuals for these systems.

3.6.1 Airbus A320 Fire Protection System Objectives

The objectives of the Airbus A320 fire protection system, as it relates to the pressurized volume includes the following:

- a) To detect the presence of smoke in the E/E compartment;
- b) To detect smoke and to extinguish fire in the lavatories;
- c) To extinguish fire in passenger/cabin compartments and other accessible areas in flight;
- d) To detect smoke in the forward, aft and bulk cargo compartments.

Detection in the E/E compartment, the cargo compartments, and the lavatories is accomplished by electronic (ionization-type) smoke detectors which are sensitive to both visible and invisible combustion gases. Each detector is the dual chamber type, one is used as a reference chamber, the other being the measuring chamber. When the two chambers become "unbalanced" by a set amount a warning is triggered.

3.6.2 E/E Compartment Detection System

Smoke emission from the E/E compartment can be sensed directly by the crew, supplemented by an ionization-type smoke detector mounted on the air extraction duct of the equipment cooling system. When the detector senses smoke, a smoke warning signal is sent to the Centralized Fault Display System (CFDS) and to the Electronic Centralized Aircraft Monitoring (ECAM) system. The "SMOKE" light on the emergency electrical power panel comes on, as do the "BLOWER" and "EXTRACT" fault lights on the ventilation panel.

A flight crew member switches the two E/E compartment fans to the override position, which serves to vent the smoke overboard. If smoke emission persists for more than five minutes, a secondary electrical power shutdown procedure is initiated to isolate the source of the smoke.

3.6.3 Cargo Compartment Alerting System

Ionization-type detectors are mounted in a dual configuration in each cargo compartment, with "and" alerting logic between the two detectors in each pair to avoid spurious smoke warnings. If only one detector of a pair sends an over-threshold signal, the other detector's circuit is checked automatically. If the detector is found to be faulty, the system accepts the single alerting signal as legitimate. Once the warning is triggered, the corresponding ventilation and heating system closes automatically. On the flight deck a repetitive chime is sounded, a red master light illuminates, a red light on the cargo smoke panel also illuminates, and a warning message is displayed on the ECAM screen.

This warning is nearly identical as that for the 757; master warning/caution light, chime, EICAS message.

3.6.4 Lavatory Alerting System

Each lavatory air extraction duct is equipped with one ionization-type smoke detector to monitor the corresponding lavatory. Each lavatory also has a fire extinguisher mounted in the waste bin. This fire extinguisher is not directly connected to the smoke detector, but fires automatically when a fusible plug in the tip of the discharge tube melts as the result of an overheat condition. If a lavatory fire occurs outside of the waste bin, a portable cabin fire extinguisher is used.

A lavatory fire alert signal is routed to the cabin area where: a) a triple chime is sounded through all cabin loudspeakers; b) a red warning light is illuminated at the Forward Attendant Panel (FAP); c) a display on the Attendant Indication Panel (AIP) shows which lavatory is affected; and d) a flashing amber light is activated at the respective lavatory's Area Call Panel (ACP). Pressing a "TONE-OFF" switch at the FAP stops the aural tone and the visual warnings on the ACP and the AIP. However, the red smoke indication light on the FAP remains on until smoke is no longer detected. The flight deck is made aware of the alert by the sounding of a single chime, an amber master/caution light illuminating, and a lavatory smoke message is displayed on the ECAM screen.

3.6.5 Conclusions Drawn from Airbus Systems

The smoke/fire detections systems used on the Airbus A320 are very similar in many regards to those used on modern Boeing, and other, commercial aircraft. Of particular interest to the present study were the features incorporated into the cabin attendant panels. Also of interest was the automatic testing and re-configuration feature of a "silent" detector's circuit when its partner (in a dual-detector arrangement) sent out a detection alarm signal. The philosophy and capabilities of the Airbus A320 smoke/fire detection systems were considered in the design of the ACES concepts.

4. TECHNICAL APPROACH

The technical approach was to identify and develop two system concepts that would comply with the prototype development requirements of the ACES system. Concepts A and B have undergone comparative evaluation for application, function, cost, procedural impact, and technical merits, while maintaining the primary objective of decreasing the time required for the flight crew to decide to land the aircraft at a

suitable airport. Sensor and detector technology databases have been expanded to include new sensors, combined function detectors, and new applications. Flight deck enhancements were improved with the development and implementation of electronic checklists and the NEXPERT system for automated flight deck functions.

4.1 ACCIDENT STUDY DATA

To assist in establishing the history of the locations of smoke/fire occurrences in commercial jet aircraft, a detailed review of the Boeing Jet Transport Safety Event Data File, FAA records and library research was made. These records cover the period of time from January 1974 through September 1989. During this period of time, an excess of 60-million (free world) flights were recorded. Figures 4-1 through 4-5 show the events, locations and numbers of smoke/fire incidents. In the figures, total fatalities are shown in parentheses.

4.1.1 Total Smoke/Fire Incidents

During the period from January 1974 through September 1989, safety data records indicate there were 892 persistent (5 minutes or more) smoke/fire events for both ground and inflight conditions, twenty of which progressed to the level of accident. It is known the total number of events is not accurate as many go unreported, however the location distribution is considered to be representative of all smoke/fire events. Of the twenty accidents, nine occurred inflight with six of these resulting in fatalities. The 892 events were further analyzed to determine which occurred inflight, and the origin of the smoke/fire, Figure 4-1.

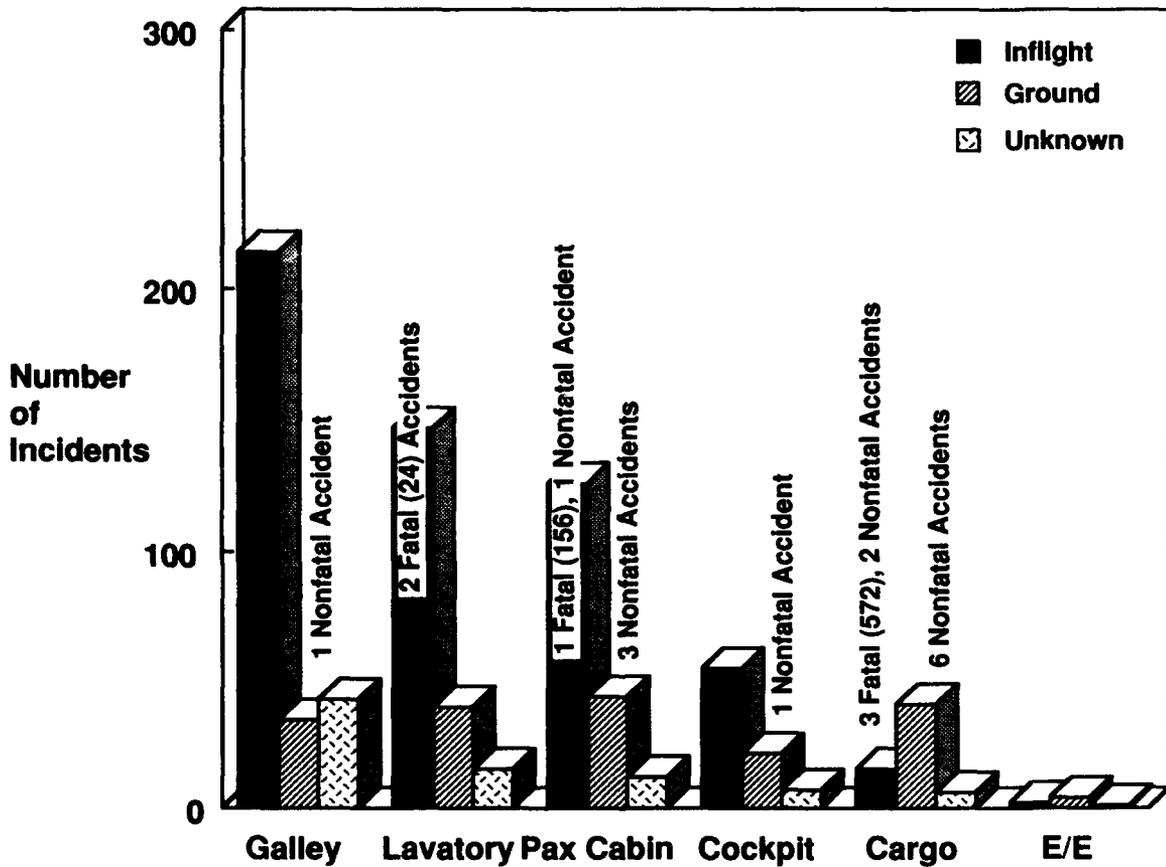

Figure 4-1. Total Smoke/Fire Incidents.

4.1.2 Total Inflight Smoke/Fire Incidents

Further analysis of the data for the 892 recorded incidents of persistent smoke and fire in the passenger cabin indicate that 558 occurred inflight. The most severe of these was the Saudi Arabian L-1011 (August 19, 1980), followed by the Pakistan Air International 707 (November 26, 1979), the Air Canada DC-9 (June 2, 1983), and Gulf Air 737 (September 23, 1983). In general, the fires with the greatest life loss potential are those originating in inaccessible areas of the airplane.

4.1.3 Locations of Incidents Aboard Aircraft

Figure 4-2 delineates the frequency and location of occurrence of fire and persistent smoke events. As indicated in Figure 4-2, the majority of the smoke and fire events are reported for the galley, followed by the lavatory and passenger cabin. The cargo compartments and E/E bay have the least reported incidents. It is not surprising that the galley has the highest number of reports, with frequent use of ovens and water boilers for inflight meal preparation. A fire in the passenger cabin generally does not propagate without immediate detection, as each of the passengers and crew are individual acute sensory detection systems.

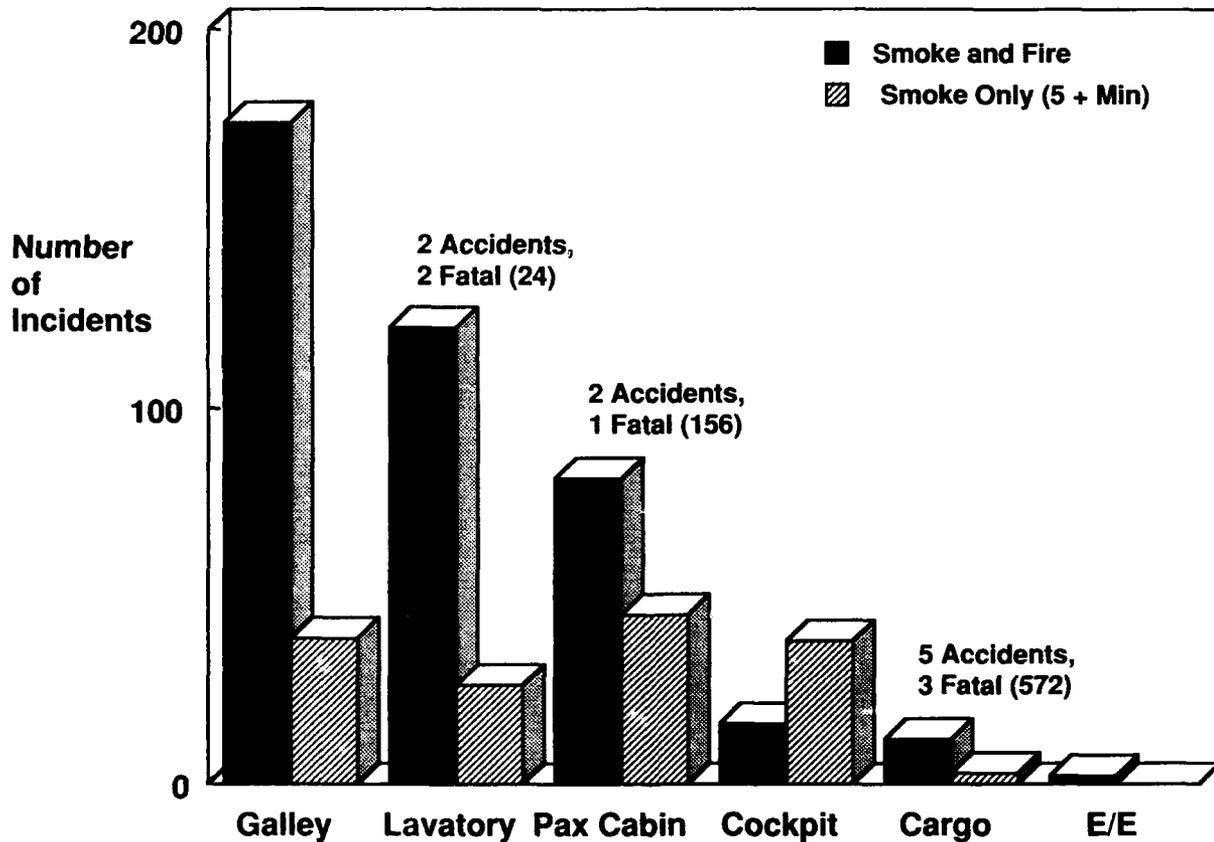

Figure 4-2. Inflight Smoke/Fire Incidents.

Passengers typically occupy one-half of the pressurized volume of an aircraft, and even less in a combi configuration. The unoccupied volume is used for airplane systems routing and cargo/baggage compartments. Some of these unoccupied areas have thermal and/or smoke detectors and some do not. The detection capabilities vary depending upon airplane type. A small fire originating in an area without detectors could propagate to a significant size before the human sensors (passengers and crew) can detect it. Studies and investigations have shown that conditions can worsen when the crew spends time diagnosing or reverifying the problem, thus delaying landing. The previously cited scenario study (reference 1, page 6) states "... most people (including pilots) do not have a complete appreciation for the mechanism by

which fires propagate and, hence, of the limited time available to respond". The standard recommended operating procedure in the industry is to land at the nearest suitable airport, rather than attempt to confirm the validity of warnings from the automated sensor systems.

As indicated in Figure 4-2, three areas of an aircraft have contributed to all six fatal accidents incurred in inflight smoke/fires during the past fifteen years. These are: the lavatory (2), the passenger cabin (1), and the cargo compartments (3).

The distribution and frequency of occurrence can be determined by examining the data for each of three areas. Figures 4-3, 4-4, 4-5 identify the location of the smoke/fire source for the lavatory, passenger cabin, and cargo compartment, respectively. The bars on each figure represent the total number of smoke and fire or smoke only events.

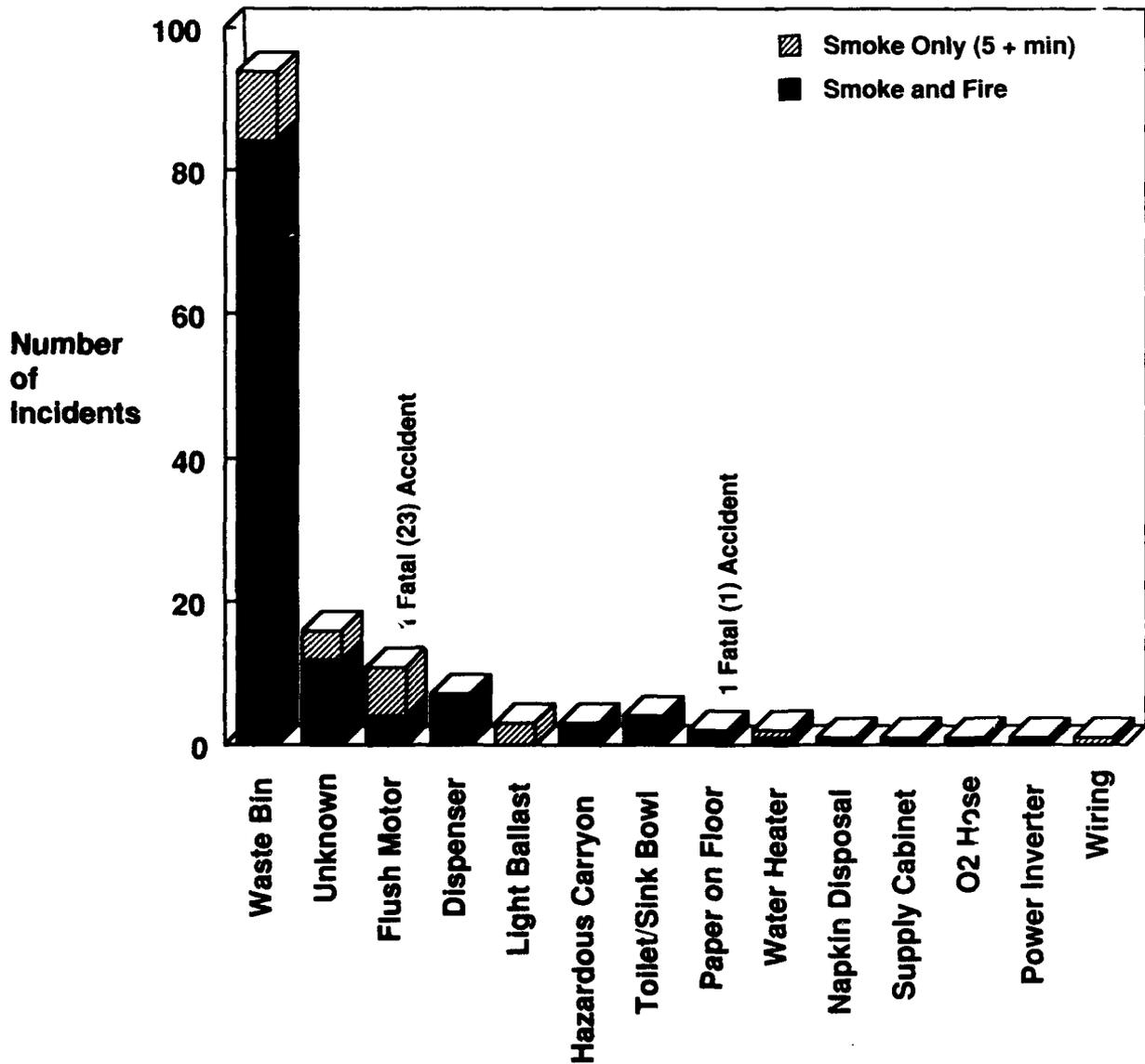

Figure 4-3. Lavatory – Inflight Smoke/Fire Incidents.

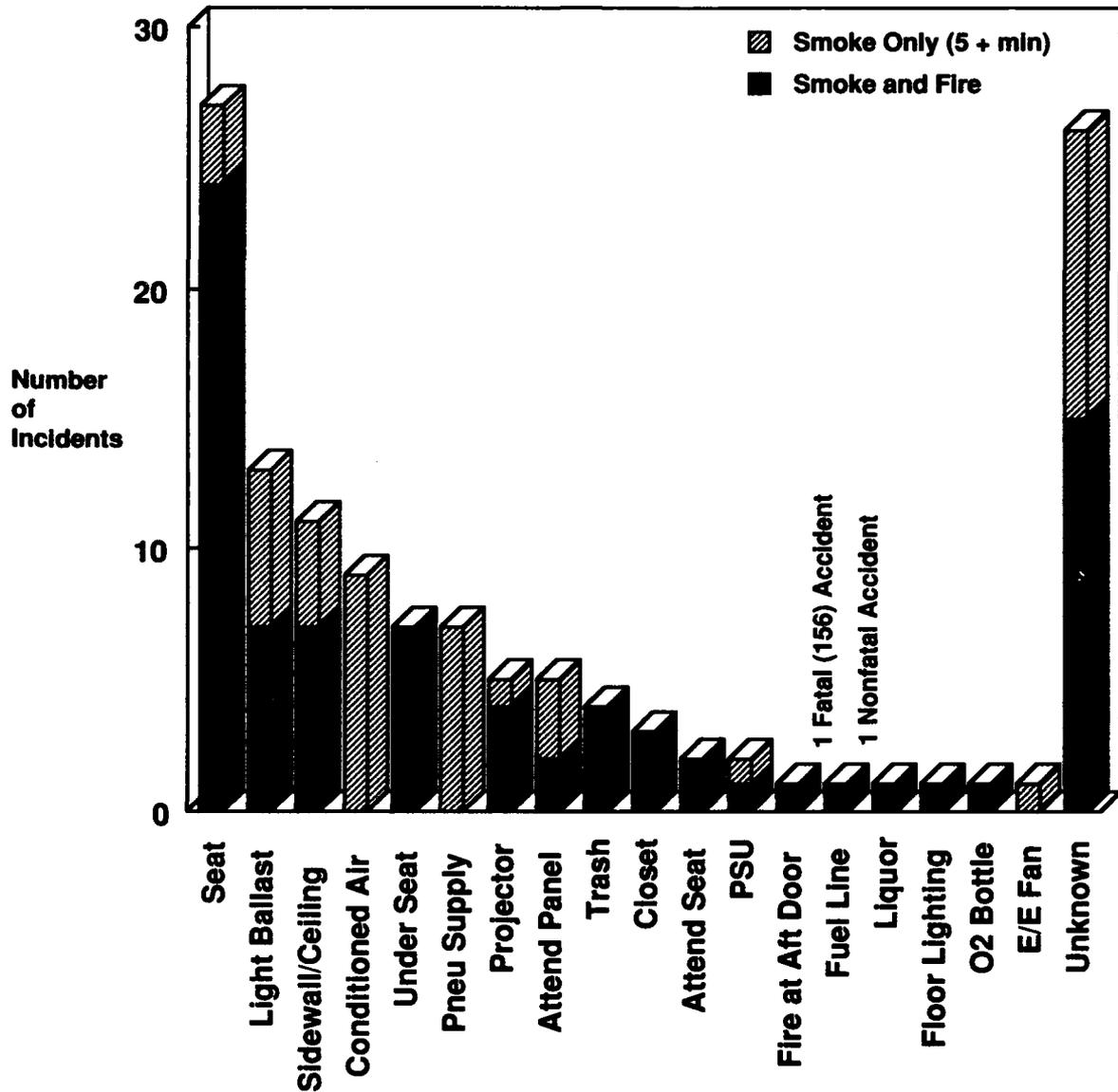

Figure 4-4. Passenger Cabin – Inflight Smoke/Fire Incidents.

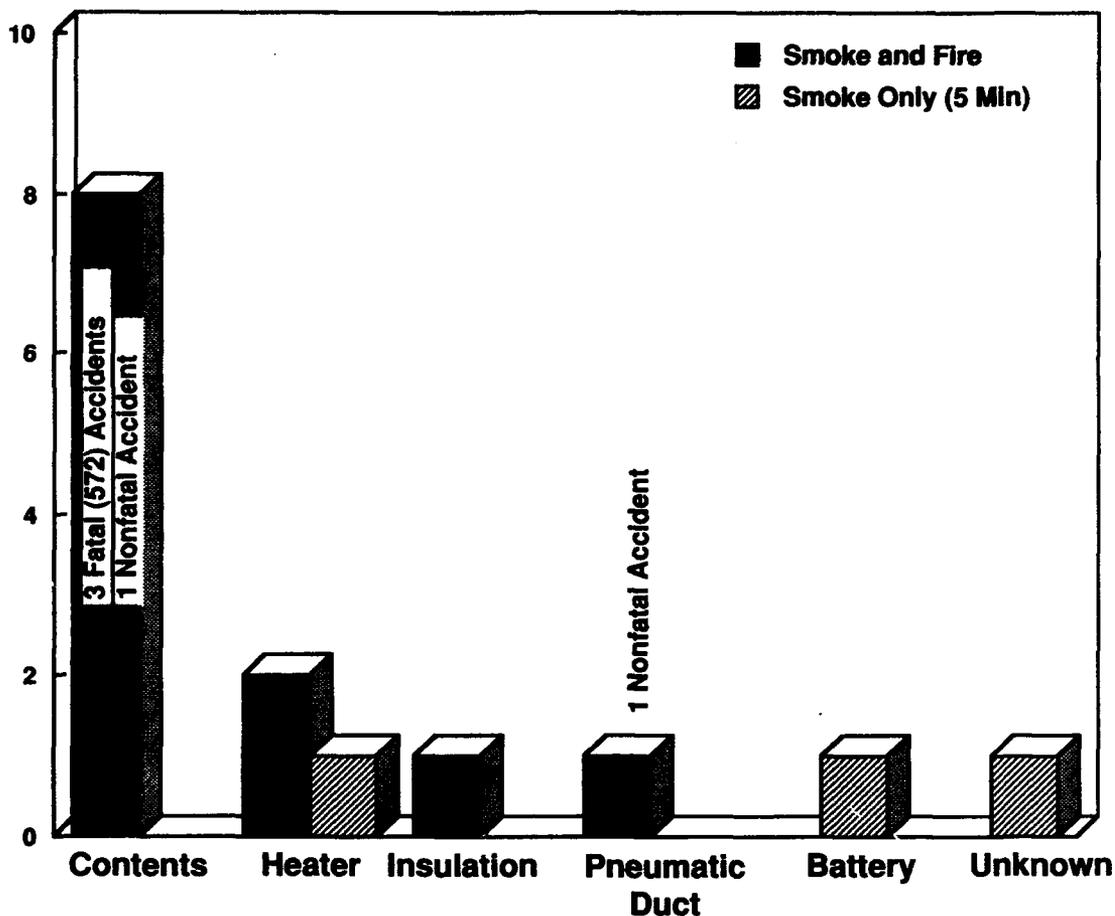

Figure 4-5. Cargo Compartment – Inflight Smoke/Fire Incidents.

4.2 FIRE SIGNATURES

In order to improve the methods and techniques of smoke/fire detection, the combustion process and the sequential phases and characteristics of each phase must first be understood.

Combustion is a chemical reaction that gives off energy. Three principal ingredients must be present for combustion to occur: heat, fuel, and oxygen. For combustion to occur, the material(s) involved must be heated to the kindling temperature, defined as the temperature at which the reaction is sufficiently rapid to proceed without the addition of heat from an outside source. An ignition source is the heat source that raises the material up to the kindling temperature. An adequate oxygen supply must be available to sustain the combustion.

Combustion of solids (i.e., wood, plastic) usually develops and progresses through a sequence of four stages: incipient, smoldering, flame, and heat (ASHREA Handbook 1984 Systems, Chapter 38, Fire and Smoke Control, page 38.10-38.12). The stages of fire progression are presented graphically in Figure 4-6 and outlined below:

- Incipient – Starts with the presence of the ignition source where invisible aerosols (less than $0.3 \mu\text{m}$) and combustion gases are emitted without visible smoke, flame, or appreciable heat being present.

- Smoldering - Combustion particles (greater than 0.3 μm) are visible as smoke.
- Flame - An actual fire is present.
- Heat - Uncontrollable heat release and rapidly expanding air mark this final stage

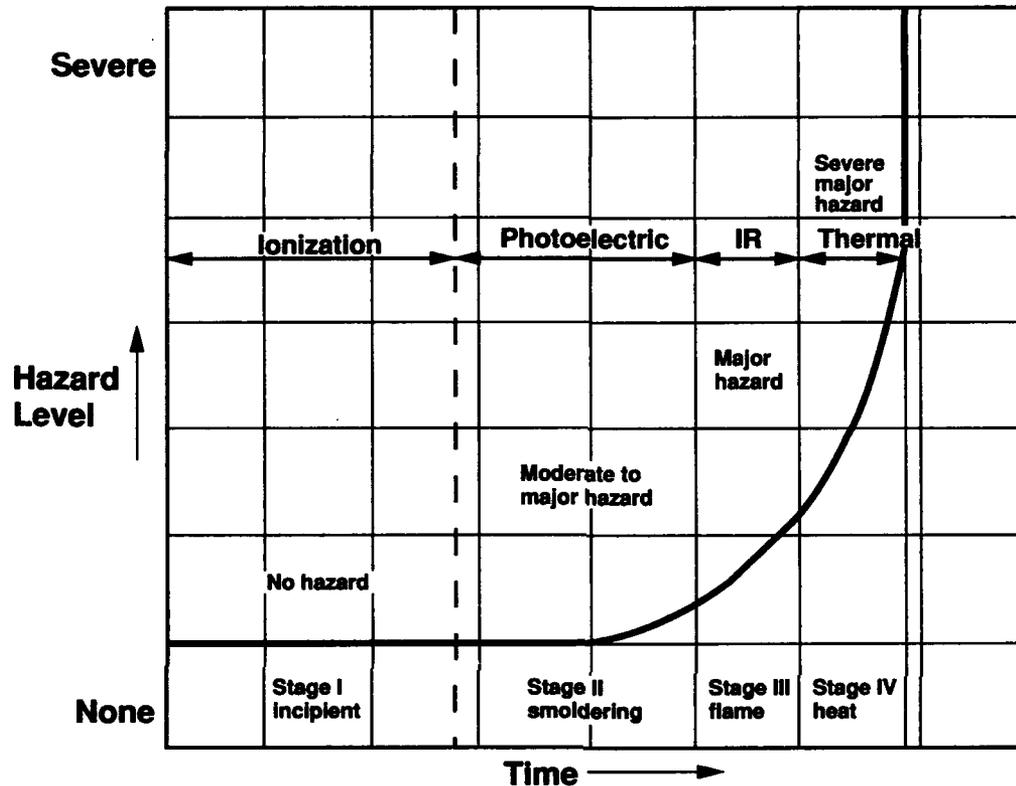

Figure 4-6. The Four Stages of Fire.

The severity of a fire increases as the fire progresses from the incipient stage up to the heat stage. The time period for the incipient stage to advance to the smoldering stage can vary from minutes to hours. The advance of the fire past the smoldering stage occurs more rapidly, typically occurring in minutes or even seconds. Combustion may skip to or start at a later stage, given the ignition source and the materials involved, thus reducing the time available for detection and suppression. Airplane furnishings and structures that restrict fire growth also impact the ability to detect the fire event.

A fire, from the moment of its initiation, causes multiple changes to the environment. These changes provide a means of detecting a fire and are referred to as fire signatures. For a fire signature to be of use, the parameter monitored must occur early in the stages of a fire to provide time for action. The signature must also be “visible” and distinguishable from the normal “background noise” that may exist in the area being monitored.

There are three basic fire signatures: gases, energy release, and aerosols. Any of the three can be used to monitor a fire event. The function of any sensor is to provide a warning as early as possible, and at the same time, provide a very high degree of protection against false alarm. The sensor must have the capability to respond to all smoke/fire events; that is, the sensor must not, for example, be dependent on the type of material burning. The types of fire signatures are discussed in the following paragraphs.

4.2.1 Aerosols

Aerosols are solid particles and/or liquid droplets produced during the earliest stages of a fire. These particles range in size from $5 \times 10^{-4} \mu\text{m}$ to $1 \times 10^3 \mu\text{m}$ during pre-ignition and become larger as the fire advances in stage, Figure 4-7. Particles less than about $0.3 \mu\text{m}$ are invisible while those greater than $0.3 \mu\text{m}$ start to enter the visible range. Particle size is important in that photoelectric detectors require visible particles to function, while an ionization sensor can be triggered by the invisible products of the fire.

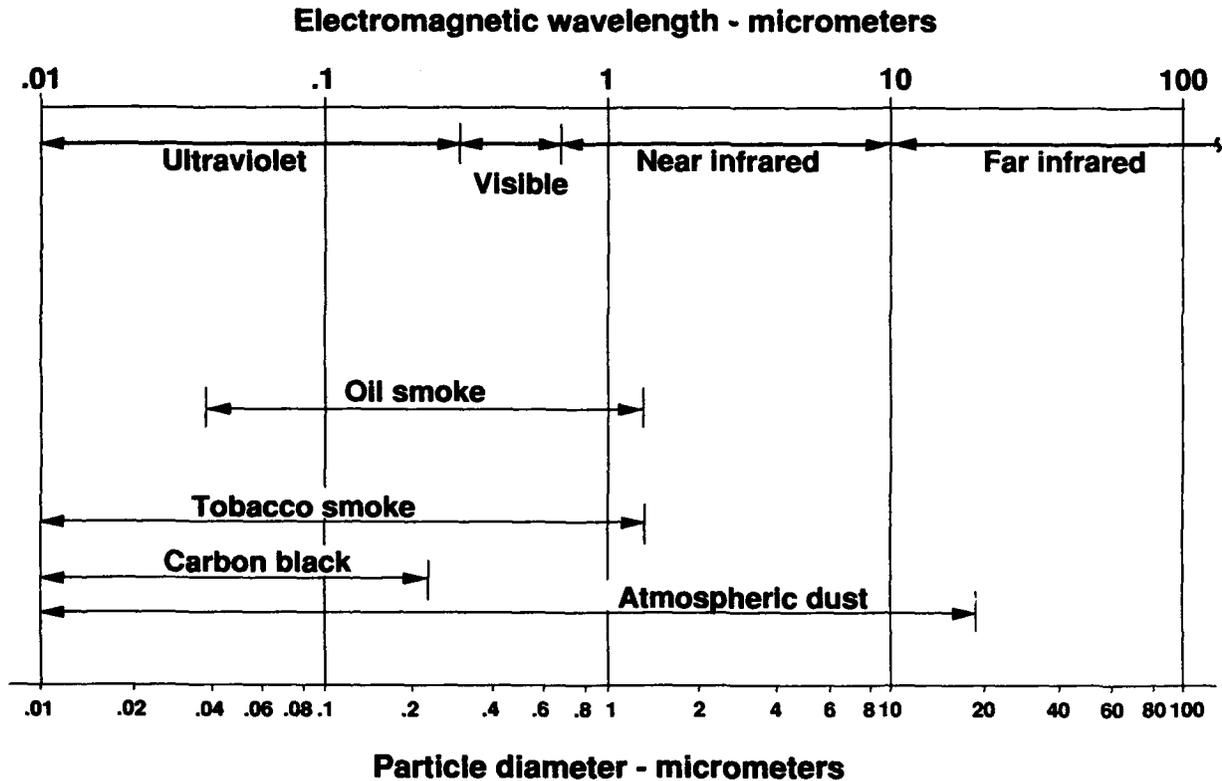

Figure 4-7. Particle Size Ranges for Common Aerosols.

4.2.2 Gases

All fires produce gaseous products. The type of gas produced is a function of the materials burned in the combustion process. Carbon monoxide (CO) is, in terms of detection, common to almost all fires, the exception being exotic combustion reactions. Detector methods for these combustion reactions are available but are not used in general fire detection applications. Most exotic gas detectors are for specific chemical/petroleum fire protection.

4.2.3 Energy Release

All fires are exothermic reactions that produce both heat and radiation in the infrared (IR), ultraviolet (UV), and visible wavelengths of the spectrum, Figure 4-7.

A strong heat signature is not produced until the later stages of a fire and is primarily dependent upon convection to move the thermal energy to the thermal sensor. The build-up of heat in a volume could range from hours for a slowly developing, smoldering, fire to fractions of a minute for a rapidly developing fire.

Infrared emissions from hydrocarbons flames are particularly strong in the 4.4 μm region due to water vapor, and account for nearly all the emitted energy. An additional IR signature is generated by flame flicker which has a characteristic energy modulation of 1.5 to 15 Hz.

An ultraviolet radiation signature appears in flames as emissions from OH, CO_2 and CO in the 0.27 to 0.29 μm region. UV has a lower signal to noise ratio than IR signatures.

4.3 SENSOR TECHNOLOGY

Several of the sensor technologies discussed in the following section do not, at this time, have application in the aircraft environment, but are included to provide a full overview of the technology. A detailed list and discussion of detector technologies is contained in a list in Appendix A.

4.3.1 Ionization

Ionization detectors are capable of detecting particles in the 0.1 to 1.0 μm range. The method of detection is to pass air (usually by natural convection) over an alpha radiation source. The alpha source will ionize the air that passes between two charged plates, allowing a current to flow, Figure 4-8. In a nonsmoke condition, the current flow is uninterrupted. When aerosols are present in sufficient amounts, the current flow is altered and an alarm is triggered. Ionization sensors are the most sensitive to fire, and susceptible to false alarm because of this sensitivity. False alarms can be caused by aerosol sprays (hairspray, etc.), tobacco smoke, and ozone.

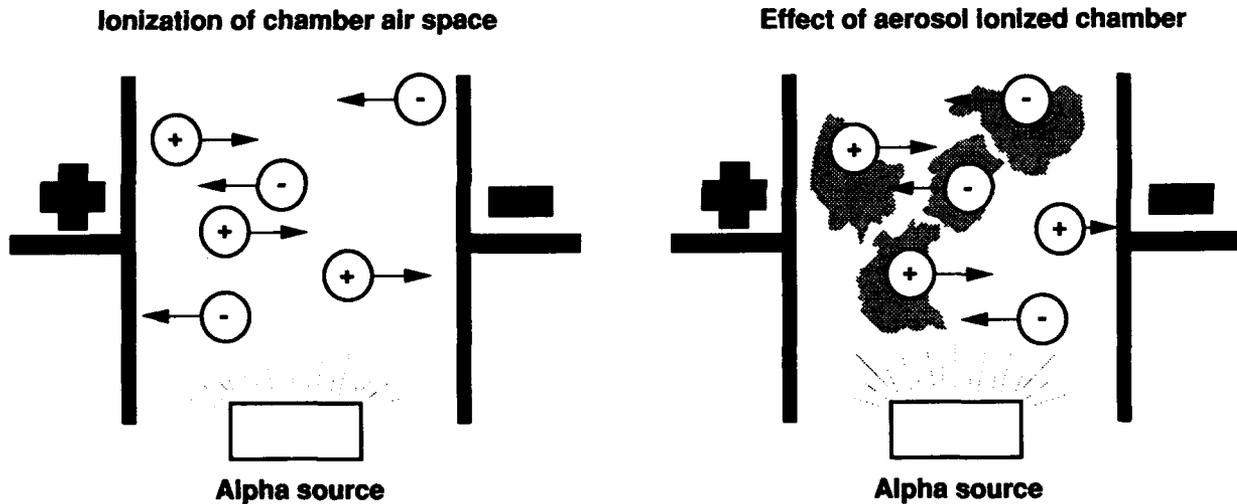

Figure 4-8. Ionization Detector.

4.3.2 Photoelectric

Photoelectric sensors use visible particles (greater than 0.3 μm in diameter) as the means to detect a smoke/fire event. Photoelectric sensors function on two different principles; light scattering and light obscuring. Each of these methods is briefly discussed below.

The light-scattering method, Tyndell effect, Figure 3-3, uses the principle that aerosol particles greater than 0.3 μm will scatter light. Particles enter the sensor, causing a beam of light to be scattered and deflected to a photocell. An alarm is sounded when the light intensity striking the photocell reaches a predetermined calibration level. This method of detection is employed in the Boeing airplane cargo compartments and E/E bays. False alarms can be initiated by nonsmoke particles such as dust, fibers, and other small particles.

The other detection method using photoelectric technology is light attenuation, Figure 4-9. This principle involves projecting a light source on a photocell. As smoke passes between the light and photocell, the amount of light striking the photocell decreases. When the light intensity that the photocell "sees" falls below a certain threshold level, an alarm signal is generated. Light-scattering smoke detectors are susceptible to false alarms and can be triggered by nonsmoke particles, e.g., dust and fibers.

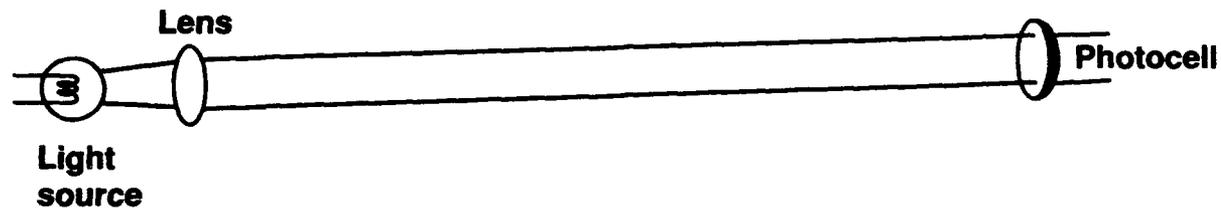

Figure 4-9. Light Attenuation Type Photoelectric Smoke Detector.

4.3.3 Radiation

Radiation sensors detect a UV/IR fire signature which is produced by combustion. The wavelength ranges from 0.001 to 0.4 μm for UV and 0.7 to 140 μm for IR. Both systems are optic detectors that utilize a lens and filter. The filter screens out the unwanted, spurious wavelengths and the lens focuses the incoming energy on a detector element.

The disadvantage of the UV/IR detectors is the requirement for the sensors to have a direct line of sight to the source of the radiation. This negates the practicality of this type of fire detection in variable geometry areas, such as found in most areas of a commercial airplane.

4.3.4 Thermal

Thermal detectors measure the temperature of an immediate area and initiate an alarm when one of several thermal parameters, such as a temperature threshold or a rate of rise (15°F/min) is reached. The output information from such sensors is usually binary, alarm/no alarm. Thermal detectors rely on free convection for the heat to reach the sensor. Heat of sufficient magnitude occurs only in the later stages of a fire, (as defined by ASHRAE, Reference 9). The late stage in which heat becomes a major component of the total fire environment makes the thermal parameter of a fire an impractical option for the first line of fire detection for most fire events. The air-conditioning system of an aircraft can further lengthen the thermal response time by dissipating heat.

The newest thermal technologies allow for monitoring of the thermal environment with a gradient as fine as 1°C and with the capability of continuous digital output. A rigorous testing program is required to identify the parameters and limits of these new thermal detection technologies for applications in first-line fire detection.

4.3.5 Laser

The index of refraction of air changes with heat causing a phase shift in a lased light beam. The light beam is also affected by smoke particles in the air (Reference 10). Both heat and smoke parameters can be monitored by one laser receiving/monitoring system. This method of detection is most effective when the system can be mounted to a very stable surface, a situation that is generally not available on an aircraft.

4.3.6 Condensation Nuclei

Liquid or solid submicrometer (0.001 to 0.1 μm) particles act as the nucleus for the formation of water droplets. The droplet (cloud density), is measured using photoelectric technology. An increase in cloud density is used to trigger an alarm. A commercial product currently on the market (Reference 11), uses multiple (up to ten) air-intake ports, enabling the surveying of several areas with one cloud chamber. This system provides a three-step analog output: warning, alert, and alarm.

This technology does not appear, at the current stage or development, to have applications in an airplane environment. Condensation nuclei technology requires increased maintenance (distilled water for the cloud chamber, contamination of the air sampling tubes), is overly sensitive, and is not, at this stage, judged rugged enough for airplane application.

4.3.7 Polymeric

Research has been conducted in this area of technology using polymeric substances that react with combustion gases causing a change in their electrical properties (Reference 12). Initial research was accomplished in the early 1970's, but no mature commercial products were found based on this technology.

4.3.8 Semiconductor

Semiconductor detectors operate on several principles. The most common detect a combustion gas by reaction of a solid-state material that initiates a change in the conductive properties of the sensor (Reference 13). Semiconductor technology is primarily being developed for toxic or explosive gas detection and has not been applied commercially to fire detection. This technology would be ideal for aerospace applications where size and weight are of concern. The literature reviewed indicates problems with sensor sensitivity to humidity and hysteresis. Applications in an airplane environment, especially within the temperature and pressure operating envelopes, would require research.

4.4 FLIGHT DECK DESIGN APPROACH

4.4.1 Objectives of the ACES Design

Automation has often been seen as the answer to problems of human error, work overload, or lack of operator dependability on the flight deck. This approach leads to a design in which "the system operates and the human monitors." However, the human is not a very effective monitor, and can suffer performance decrements under emergency procedures when he/she has not been actively involved in controlling the system. Therefore, the basic design for ACES was based upon the following philosophy:

- a) Equipment and software is on board to help the flight crew perform their job;
- b) Any automatic systems are subordinate to the pilot's discretion and legal responsibility;
- c) The design should first decide what automation should do, not what it can do;
- d) The design should decide how needed information can best be displayed;
- e) Flight deck improvements should be toward the development of error-tolerant system design.

4.4.2 Alerting System Design

The alerting system design for the ACES concepts follows the alerting philosophy described in Section 3.5.1 and incorporates the basic components of the 757-200 alerting system as described in Section 3.5.2. The primary difference is in the more positive alerting of the cabin attendants for those alerts for which they have responsibility, and in the enhanced awareness of these events that is communicated to the flight deck. The aspects of these differences are covered in more detail in the sections on Concepts A and B.

4.4.2.1 Master Warning/Caution

The Master Warning/Caution switch-indicator for the ACES concepts is identical in function and form to that currently used on the 757. This indicator is the first element in the alerting system for all warning or caution level alerts. The indicator lights, red for warnings (top half) and amber for caution alerts (bottom half). The alert lights occur coincident with the sounding of an aural alerting sound, which is a "fire bell" for all fire warnings, and a "beeper" tone for cautions other than ground proximity alerts.

4.4.2.2 Alert Response Procedures

The alert light is turned off, the alerting tone silenced, and the system reset when either crewmember presses the Master Warning/Caution switch-indicator. This first action by the crew is followed by attending to the alert display on the upper EICAS for information on the nature of the alert.

On the left portion of the upper EICAS display, warning level alerts are indicated by a message (in red) which identifies the location, system or component, and nature of the alert. Caution level alerts are indicated with an amber message, while advisories are amber but indented one space. The messages are listed in order of urgency (warnings, then cautions, then advisories), and within each category in order of occurrence, with the most recent on top.

4.4.3 Flight Deck Enhancements

The ACES concept enhancements to the basic 757-200 system have been designed to minimize the time needed to respond to the fire itself, and to minimize the decision time for diverting to an alternate airport. The enhancements developed for Concepts A and B have been based upon an analysis of inflight incidents, in-house Boeing research efforts in this area, and conclusions drawn from the Dunlap scenarios. The primary changes involve the addition of software and display formats that assist the crew in their procedures following a smoke or fire alert. Only slight modifications have been made to the alerting system based upon the results of several years of research contract work with NASA/FAA (Reference 8).

4.4.3.1 Electronic Checklist

Retrieval and performance of checklists has been identified as one source of delay and procedural errors on the flight deck. A recent review of the Aviation Safety Reporting System database on airline incidents indicated that, in a period of a little over one year (mostly 1987), over 50 incidents occurred that were related to errors or difficulties in the retrieval and/or processing of checklists (Reference 14).

One of the primary enhancements of ACES on the flight deck will be in the use of electronic checklists for crew procedures. This feature will not only save time, but will ensure that the correct procedures are presented to the crew for implementation. The electronic checklist will be used in both Concepts A and B, and will be displayed up on the lower EICAS display.

4.4.3.2 Cabin Attendant Panel

Both Concepts A and B utilize a "Cabin Attendant Panel" mounted at three locations in the cabin: forward, mid, and aft. This panel is utilized for smoke or fire events for which the cabin attendants have primary responsibility. These include:

- Lavatory smoke/fire
- Galley smoke/fire
- Attic smoke/fire

The panel is similar to the cabin smoke warning system that is provided on the Airbus A320 (and described in Section 3.6.4), but functions somewhat differently. The ACES Cabin Attendant Panel provides the following:

- a) A warning light and a tone to alert the attendant(s);
- b) The warning light will also be a switch. Depressing the switch will turn off the tone and send a signal to the flight deck;
- c) Location/system lights that identify which detector has been triggered;
- d) A switch to "clear/reset" the panel and the alert sent to the flight deck.

4.4.3.3 Flight Deck Alerts for ACES

In addition to the areas that will be directed to the cabin attendant stations (with a corresponding caution alert relayed to the flight deck), there are a number of areas that are the primary responsibility of the flight deck crew:

- Cargo bay smoke/fire

- E/E bay smoke (no flight deck procedure)

- Air-conditioning pack duct smoke

4.4.3.4 Inflight Diversion Planner

Once the crew has completed the appropriate procedures to address the smoke/fire event, the decision must be made whether to divert to a closer airport or to continue on course to the destination. Diversions are called for whenever a smoke/fire alarm is sounded and when it cannot be confirmed that the alarm is false. If such a condition exists, it is imperative that the captain be able to reach a decision, determine which airport to divert to, obtain clearance for the new route, and execute the diversion as soon as possible.

To best facilitate this process, an "inflight diversion planner" has been selected for application to the ACES concept. This expert system program was developed by Boeing using NEXPERT OBJECT application software. The program provides expert system recommendations on possible alternate airports and allows the pilot to assess various factors used in the analysis.

4.4.3.5 Synoptic Display

The Boeing 757 operations manual states: "It should be stressed that for persistent smoke, or a fire that cannot be positively confirmed to be completely extinguished, the earliest possible descent, landing and passenger evacuation should be accomplished."

Currently, the only way to ascertain whether a smoke/fire event is completely extinguished is to determine whether the detector in that area remains silent, or re-triggers with a resumption of the smoke or fire that initially triggered the alarm. However, if the detector has been damaged in the smoke/fire event, a silent detector might mislead the crew temporarily in regards to the safety of the aircraft, and thus delays the needed decision to divert. Lingering smoke or contaminants can retrigger the alert even if the source is suppressed.

Contrarily, the crew may be encouraged to divert and/or land quickly, with subsequent evacuation of passengers, by a detection and alerting system that has faulted (in absence of a smoke or fire condition) and repeatedly triggers, even after appropriate extinguishing actions have been taken. There have been several reported cases of this type (but few in 757's), and in a number of these cases, injuries have been sustained by passengers in evacuating the aircraft. In one recent case, 31 passengers were injured and no evidence of a fire was found, (Boeing Jet Transport Safety Event Data File). Incidents such as these point to the need for better detection and continual monitoring of the status of the smoke/fire event, to enable the crew to make more informed decisions on diverting and secondary fire fighting.

For Concept B, the ACES designed a "synoptic display" capability to provide additional status information or situational awareness of the smoke/fire event. Information is primarily intended to provide feedback on the effectiveness of the procedures taken by the flight deck or cabin crews to address the problem, or provide supplemental procedures that would be customized to the evolving situation.

4.4.3.6 Other Alerting System Enhancements

Several additional enhancements have been proposed for the Concept B flight deck. One enhancement is the addition of a cautionary discrete light that will indicate "CABIN SMOKE" and will be located adjacent to

the "FIRE" discrete light. As a caution light, the color will be amber rather than red. This will provide some redundancy in case of EICAS failure and additional situational awareness for alerts that are the responsibility of the cabin attendants.

Another enhancement for Concept B is the addition of a pilot-selectable voice message for warning and caution level alerts. This voice message provides a second channel of information on the nature of the alert, the affected component, and its location. These two features have not been included in the PC-based demonstrations of the ACES concepts however.

The additional sensors required for the ACES concepts are reflected in the addition of alerts available on the upper EICAS display. Some of the alerts are the same for both concepts, while others are different, or only occur for Concept B. The additional alerts that have been identified for the two concepts are described in Section 5.

4.4.4 ACES Demonstration Software Design

To illustrate the flight deck and cabin attendant functionality of the ACES concepts, a PC-based demonstration was developed. This demonstration included formats for all the enhancement elements, including the alert display, the electronic checklist, the cabin attendant panel, the inflight diversion planner, and the system synoptic display. The software for this demonstration was written such that the procedural steps that the crew, or cabin attendants, would follow in responding to a smoke/fire event under the ACES concepts could be sequentially completed by simply interacting with the PC-based displays with a mouse and a few function keys.

The software that would be used to implement the ACES concepts on a 757 platform would not necessarily be identical to the software designed for the demonstration modules. Therefore, the following description of the software design is primary applicable to the demonstration system and not necessarily to a 757 implementation design.

The demonstration software was designed to be as flexible as possible so that changes in functions or design could be rapidly accommodated. The software system enables the user to define the sensor environment that postures the problem being simulated. The user can exercise options to retrieve procedures or to display synoptic information reflecting the aircraft's current situation.

The system consists of a graphic interface and an embedded expert system, NEXPERT OBJECT. The interface is a Microsoft Windows application written in C. The expert system consists of a rule base containing pilot/engineer knowledge and a supporting object architecture with an inference engine to reason about the current situation. "WinMain" is the driver for the ACES system. It is a Microsoft Windows program and therefore performs routine windows housekeeping. All global variables are defined in this program. These include variables to define which sensors have been selected by the user, messages to be sent to NEXPERT OBJECT, and variables associated with the objects in the graphic user interface.

Figure 4-10 is a context diagram of the software design, showing information inputs from the pilots QRH and operations manual, from Boeing pilots, and the resulting procedures, displays, and control logic for the various smoke/fire detection areas.

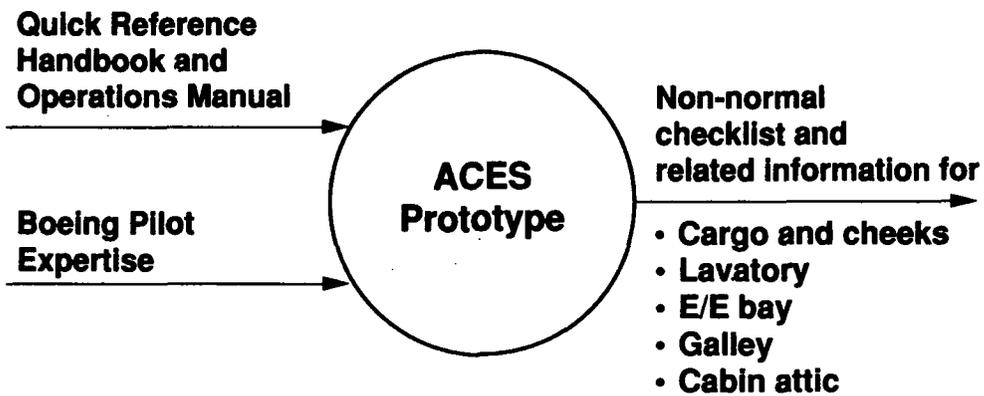

Figure 4-10. ACES Context Diagram

Figure 4-11 diagrams the top level structure of the ACES control software, while Figure 4-12 shows a similar structural layout for the knowledge base in the NEXPERT OBJECT expert system program. Additional data flow diagrams are presented in Appendix C.

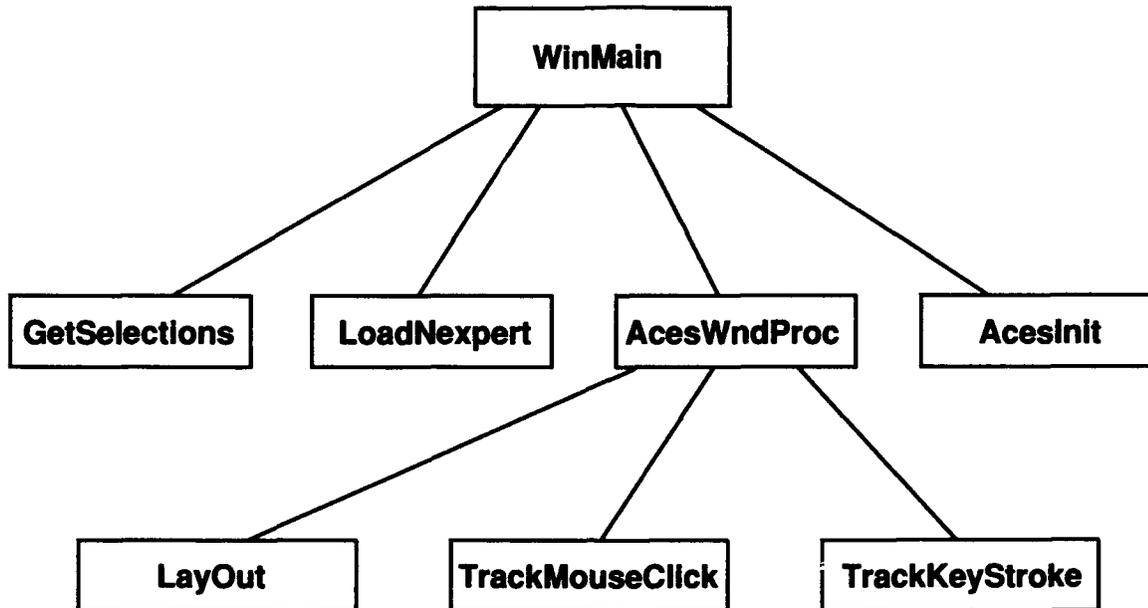

Figure 4-11. The Overall Structure Diagram of ACES

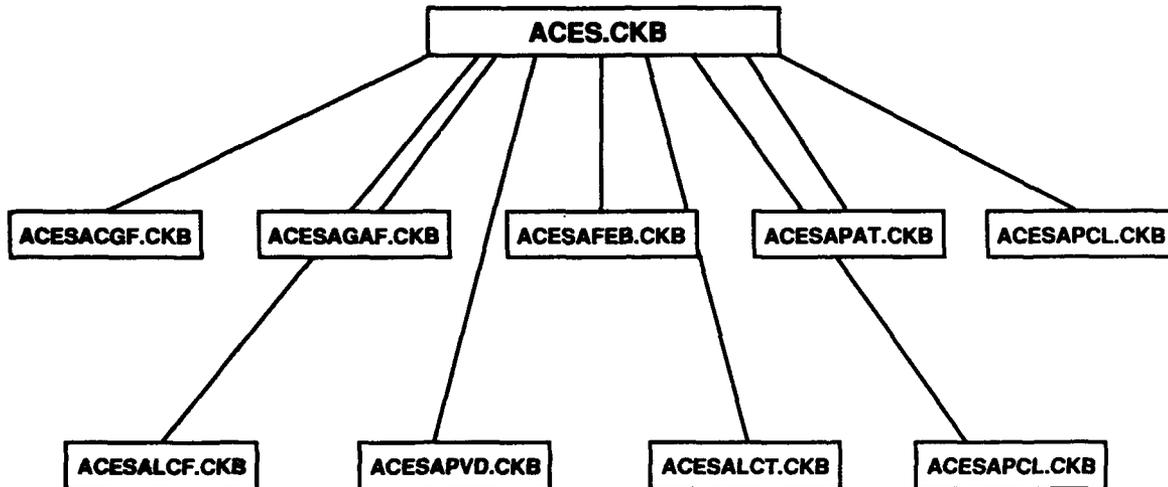

Figure 4-12. ACES Knowledge Base Partition

5. CONCEPT A

5.1 GENERAL DESCRIPTION

One of the requirements of this contract was to identify a candidate airplane(s) for the purpose of this study. The 757-200 aircraft has been selected as the baseline aircraft on which to develop the ACES concepts. The details of the baseline aircraft are presented and discussed in Section 3.

Concept A defines specific improvements in detection and communications capability which can be realized in the performance of the baseline aircraft. The number and type of smoke/fire detectors and areas to be monitored have been increased. Communications between the flight deck and cabin crew are significantly enhanced with the addition of a new cabin attendants panel. A functional block diagram, Figure 5-1, illustrates improvements which can be achieved in the 757 with the addition of an ACES Concept A. Table 5-1 lists the costs of the Concept A smoke/fire detector components. These costs are included in the overall cost model discussed in Section 5.6. Concept A will provide continuous sensor and system operation evaluation and, in addition, will provide specific and detailed maintenance diagnostic information.

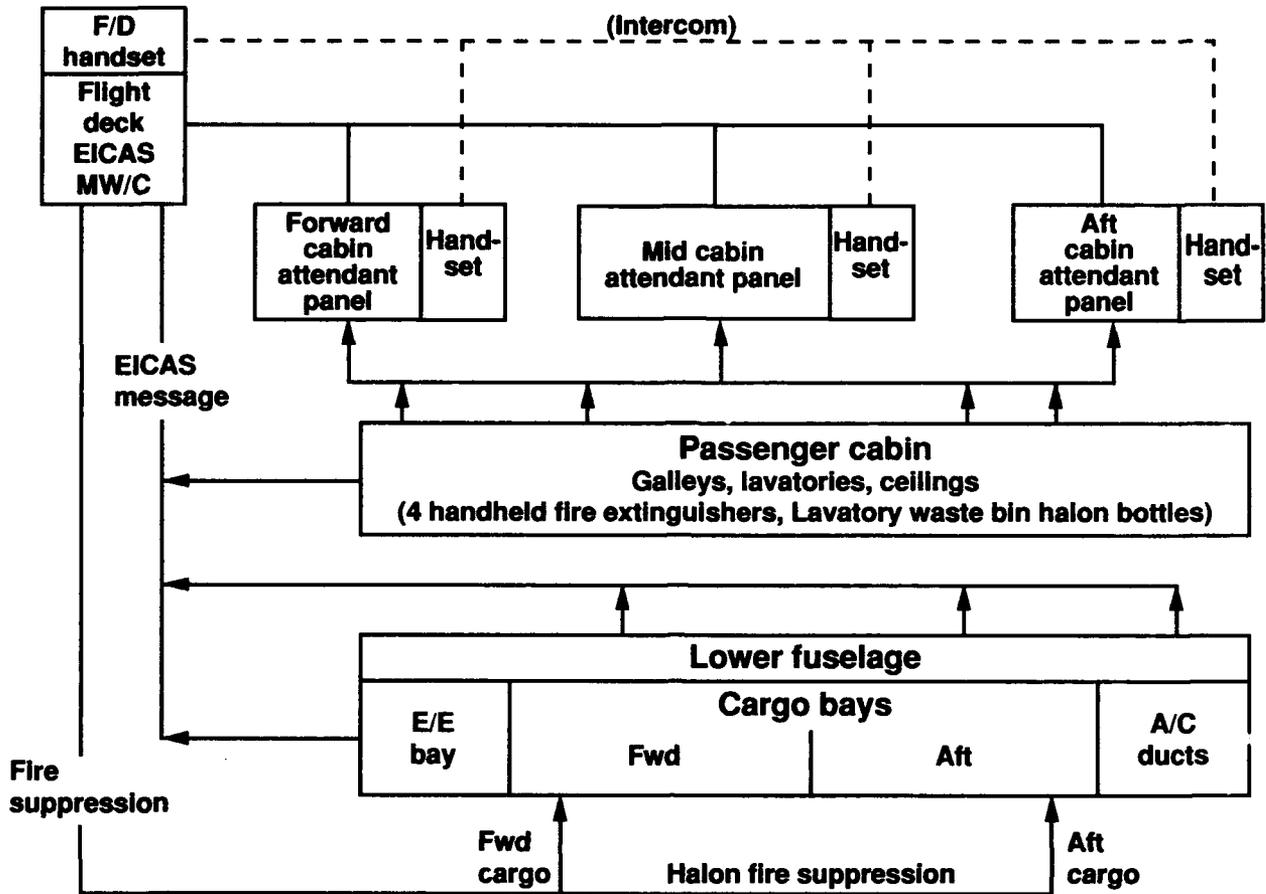

Figure 5-1. ACES Concept A.

Table 5-1. Concept A 757-200 Component Costs.

Locations Monitored	Units	Unit Cost	Cost	Type- Manufacturer	Part No.
Cargo and lower lobe					
Fwd (1, 4)	2	\$210	\$420	Photoelectric - Gamewell	RT-7
Aft (1, 4)	2	\$210	\$420	Photoelectric - Gamewell	RT-7
Lavatory					
Ceiling (3)	4	\$225	\$900	Ionization - Jamco	PU90-461R3
Under counter (3)	4	\$225	\$900	Ionization - Jamco	PU90-461R3
Forward E/E bay					
Supply air (1)	2	\$788	\$1,576	Photoelectric - Autronics	2156-204
Exhaust air	1	\$788	\$788	Photoelectric - Autronics	2156-204
Galley					
Ceiling (3)	4	\$225	\$900	Ionization - Jamco	PU90-461R3
Passenger area					
Attic (3, 4)	6	\$210	\$1,260	Photoelectric - Gamewell	RT-7
A/C (3, 4)	4	\$1,030	\$4,120	Photoelectric - Geamatic	SDS-300A
Total	29		\$11,284		

Note 1: Installed as pairs with "and" logic

Note 2: Conditioned air upstream of the mix manifold

Note 3: Connected to the flight/deck communications panel

Note 4: Estimated, not flight-qualified hardware in current commercial configurations

5.2 DETECTOR TYPES

The criteria for detectors chosen for use in Concept A were: function, reliability, false alarm protection, and a net benefit (improvement) over the current system.

Sensors by four different manufactures, totaling 29 detector units, makes use of two detection technologies: photoelectric and ionization. These two methods of detection are discussed in detail in Section 3.3.1 (technology) and Section 5.2.1 (application).

5.2.1 Ionization

Ionization detectors were selected for applications in the lavatory and galley areas. Ionization sensors are triggered by small invisible (less than 0.3 μm) aerosols, that are present in the initial, incipient stage of a fire. This sensitivity, which may contribute to false alarms, was not felt to be a detriment as all areas to be monitored by ionization sensors can be inspected by the cabin attendants in an expedient manner.

The ionization detectors selected for use in the Concept A system are manufactured by Jamco (P/N PU90-461R3), Figure 3-7. These sensors are currently in use in the lavatories on Boeing airplanes. Mounted flush to the ceiling, particles/smoke reaches the unit by free convection. The detector employs a dual chamber configuration to reduce the incidence of false alarm. When the two chambers become

sufficiently "unbalanced" the detector unit will generate an alarm. The detector provides a binary, on/off, output signal. The alarm is made known in four ways; a visual alert at the cabin attendant panels, a visual alert to the flight deck, a chime heard over the passenger address system, and the alarm horn internal to the detector unit.

Jamco sensors have a proven history of reliability/maintainability in aviation application, demonstrating their use on the entire fleet of Boeing airplanes. This experience (since November 1986) has shown the incidence of false alarms to be minimal and is considered acceptable.

5.2.2 Photoelectric

Photoelectric sensors, triggered by visible (greater than 0.3 μm) airborne particles are not, inherently, as sensitive as ionization sensors. Photoelectric detectors react to the smoldering phase of the fire (Section 3.2.1) when larger particles are present. The reduction in sensitivity (compared to ionization) is considered a positive feature for use in unattended/inaccessible areas of the airplane. Reduced sensitivity lessens the chance for spurious alarms. False alarms, in areas which can not be inspected, lead to aborted flight plans and unnecessary emergency evacuation, which inevitably results in passenger injuries. Of greater concern is false alarms eroding flight deck confidence in the system, which may result in time not used to its greatest efficiency when an actual emergency occurs.

Three types of photoelectric detectors have been identified for use in the Concept A system. Two are of the light-scattering type one manufactured by Autronics and the second by Gamewell, (Reference 15). The third photoelectric detector is a light-attenuation type made by Geamatic, (Reference 16).

The Autronics detector, previously shown in Figure 3-3, is a binary (on/off) system currently installed in the forward E/E bay and the cargo compartments of the 757. This detector is activated when particles entering the light chamber scatter sufficient light to shine on the detector's photocell. Alarm occurs at a particle level comparable to about 15% obscuration measured over a distance of one foot. The current Autronics detector, as used on Boeing airplanes, uses a bulb (white light) for the pilot light. For Concept A the light source will be upgraded to a LED light source. The use of a LED light will improve the long term stability of the detector, service life and reliability/maintainability. A bulb type light source will "drift" (not providing a constant output) with age.

The Gamewell RT-7 sensor, Figure 5-2, will be used to monitor the cargo compartments and main deck attic area. The RT-7 is an open area detector, with particles reaching the sensor by free convection. This unit is addressable and has a binary output signal. A pulsing infrared light source is employed to provide false alarm protection. In the unit's current commercial configuration, the sensor must "see" particles on four consecutive pulses to trigger an alarm signal (a pulse occurs once every 2 seconds). Thus the detector uses an 8 second sampling time/"window" to reduce false alarms. The Gamewell unit is not currently available as a flight-qualified sensor, but the technology is straightforward and should not be difficult to repackage into a flight-quality configuration. The Gamewell model RT-7 also features an integral, self restoring, thermal detector. When the body of the sensor reaches 135°F an alarm signal is initiated. The thermal set point of 135°F is the temperature limit available in commercial configurations. The thermal alarm threshold would require changing for airplane application as soak temperature in the cargo compartments can exceed 150°F in worst case, airplane on the ground, conditions.

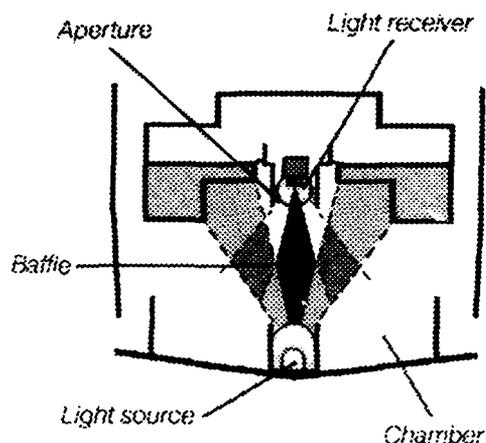
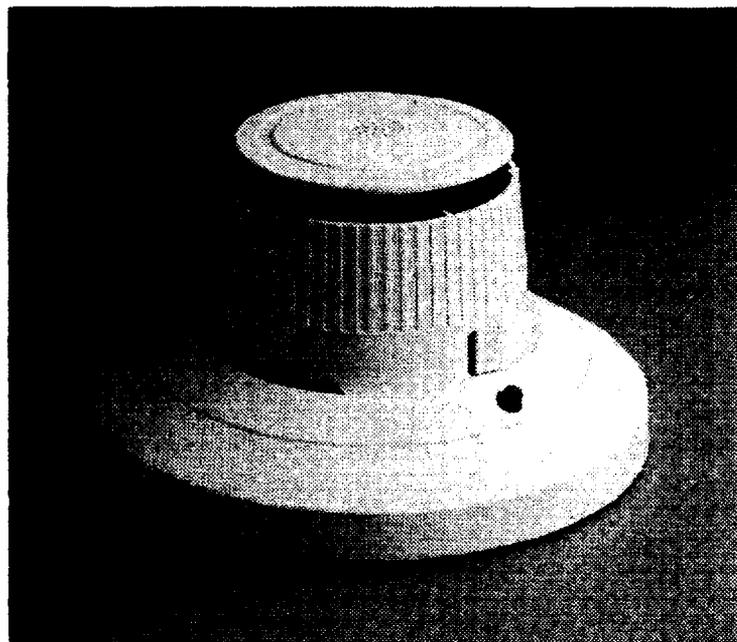

Figure 5-2. Gamewell Consecutive Pulse Photoelectric Detector.

Geamatic detector, model number SDS-300A, shown in Figure 5-3, is a photoelectric detector of the light-attenuation type. The detector will be used to monitor conditioned air for smoke as the air exits the packs. The rationale for monitoring this area is presented in Section 5.3.5. The detector uses an infrared emitter and a receiver. Short pulses are continuously emitted for detection of smoke. When smoke is present, the light reaching the receiver is attenuated, that is, the receiver "sees" less light. When the light reaching the receiver falls below a minimum threshold, an alarm signal is generated. The detector provides a two-step output, an initial pre-warning and a second alarm if light reaching the receiver continues to diminish.

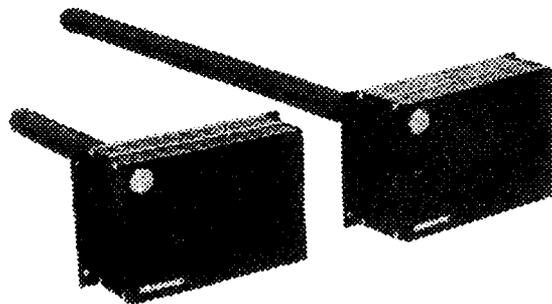

Figure 5-3. Geamatic Light Attenuation Photoelectric Detector.

Every second hour the SDS-300A emits a calibration signal to determine the unit's state of cleanliness. The calibration signal is compared with a stored reference signal and, if required, the strength of the emitted signal is boosted to compensate for dirt and dust buildup. The amount of recalibration that has taken place, and hence the state of cleanliness, is indicated in 15 stages, with stage 1 being the cleanest stage. When the unit reaches stage 12, a maintenance signal is generated.

The detector can be set to alarm at four levels of sensitivity, with the highest level of sensitivity resulting in a shorter time between required maintenance. Maintenance consists of removing the sensing probe, wiping with cleaning fluid, and placing the probe back into the unit. Recalibration automatically takes place when the unit is switched back on, that is, the unit "recalculates" its state of cleanliness.

5.3 LOCATIONS MONITORED

Several additional areas to be monitor in the pressurized volume of the aircraft have been identified based on the smoke/fire incident/accident data collected and analyzed in Section 4.1. The areas to be monitored in the proposed Concept A ACES system are discussed in detail in the following sections.

5.3.1 Cargo Compartments

In Concept A, the forward and aft cargo compartments are to be monitored by dual Gamewell consecutive pulse, photoelectric detectors, Figure 5-4. These detectors will replace the current system now being used on the 757. The Gamewell detectors are free convection detectors, relying on smoke rising to the ceiling to reach the unit. The Gamewell detectors will be mounted as a pair in each cargo compartment and coupled with "and" logic. To meet the 60-second detection requirement (Section 1.1.1), a number of sensor pairs may be required (the exact number of pairs can only being determined by analysis and/or testing).

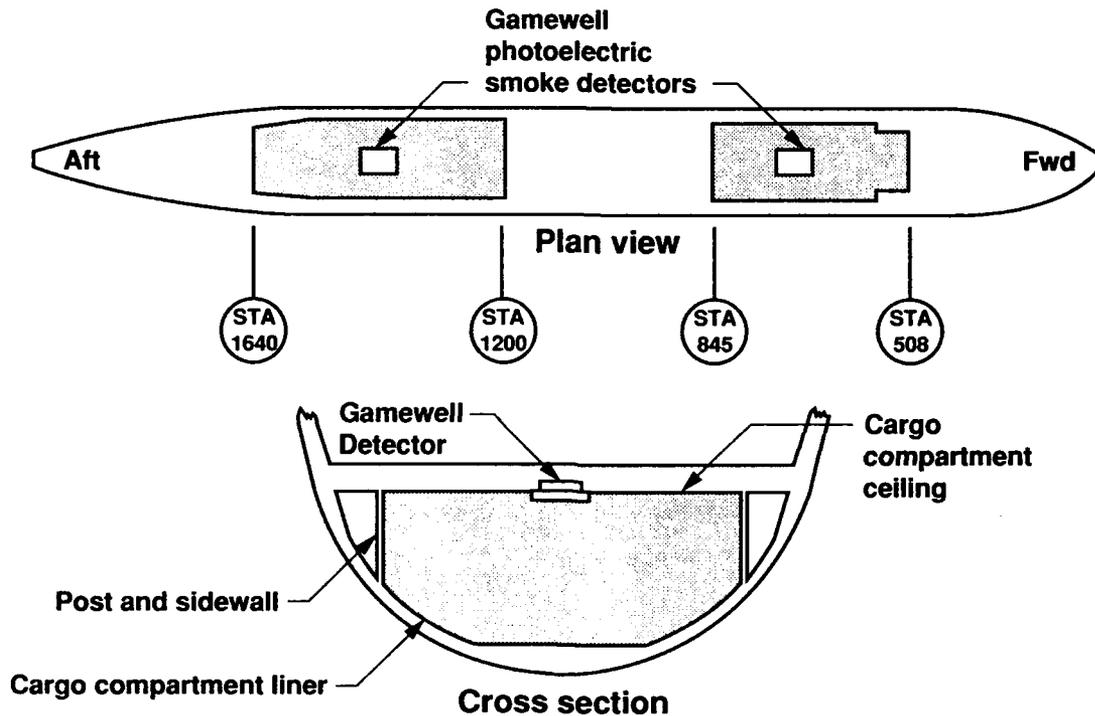

Figure 5-4. Lower Cargo Compartments.

The Gamewell detector consists of two components; the sensor head and the "smart" base. The sensor head (Figure 5.2) contains the infrared light source, the light receiver, baffle to reduce entrance of foreign material, and an aperture to shield the light source from the light receiver. The base contains the "smarts" of the detector, the pulsed light source, event counter, alarm generator, aircraft interface and a unique address. The base pulses the LED light source once every two seconds. If smoke is present, light from the LED reaches the light receiver and a smoke event is noted. If four consecutive pulses result in light reaching the light receiver the base generates an alarm signal. The ACES system will provide additional false alarm protection by linking two Gamewell detectors with "and" logic, thus both detectors must "see" smoke before an alert is forwarded to the EICAS computer and the flight deck, Figure 5-5.

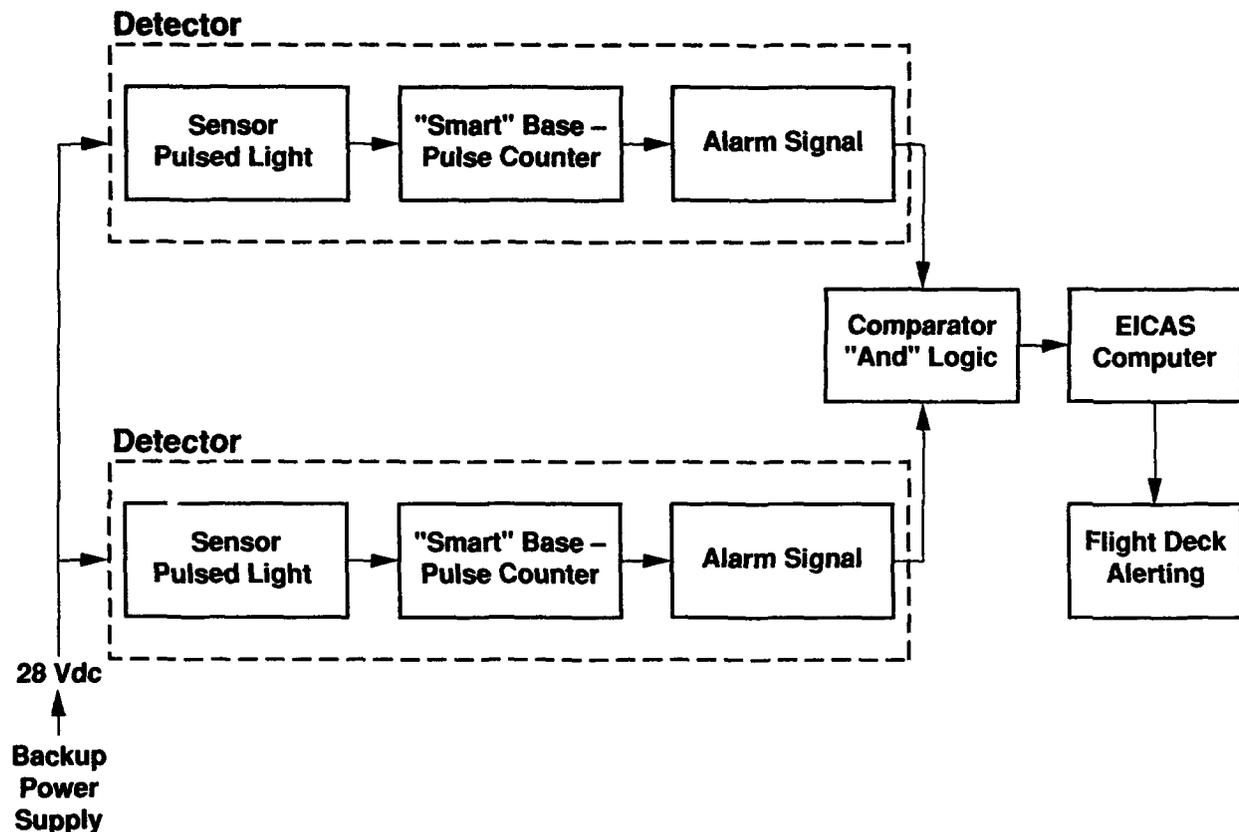

Figure 5-5. Cargo Compartment Detection System.

Each base will be recess above the cargo compartment ceiling such that the sensor head will protrude only slightly below the ceiling. Maintenance of the sensor will consist of removing a protective cover (needed to protect the sensor head from the severe pounding which takes place in a cargo compartment), snapping the sensor out of the base and replacing with a clean unit.

The Gamewell system allows the baseline 757 air sampling components; ducting, both blowers, pressure switch, and plenum (shown in Figure 3-6), to be removed. The proposed system will have lower installation costs, reduced maintenance requirements, and lower recurring system costs as a result of fewer system components. Most importantly will be the reduction in the potential for false alarms. The Gamewell system would reduce the minimum equipment list (MEL) on the baseline airplane from two items per cargo compartment (one functioning detector and one fan) to one, a functioning detector.

5.3.2 Lavatory

The lavatories, easily accessible by the cabin attendants, will be monitored by the more sensitive ionization detectors. The current ionization detectors used in the lavatories will be upgraded by replacing the existing detector (Jamco P/N 90-499R3) with a detector that has an output signal feature (Jamco P/N PU90-461R3). An additional smoke detector (Jamco P/N PU90-461R3) will be installed under the sink counter/paper products area to provide more complete monitoring of the lavatories Figure 5-6. The reasoning for more thorough monitoring of the lavatory arises out of the accident data (Section 4.1) and the concern for flammable materials both stored and disposed under the lavatory counter. Both detectors will be interfaced with the cabin attendants' panel and with the flight deck.

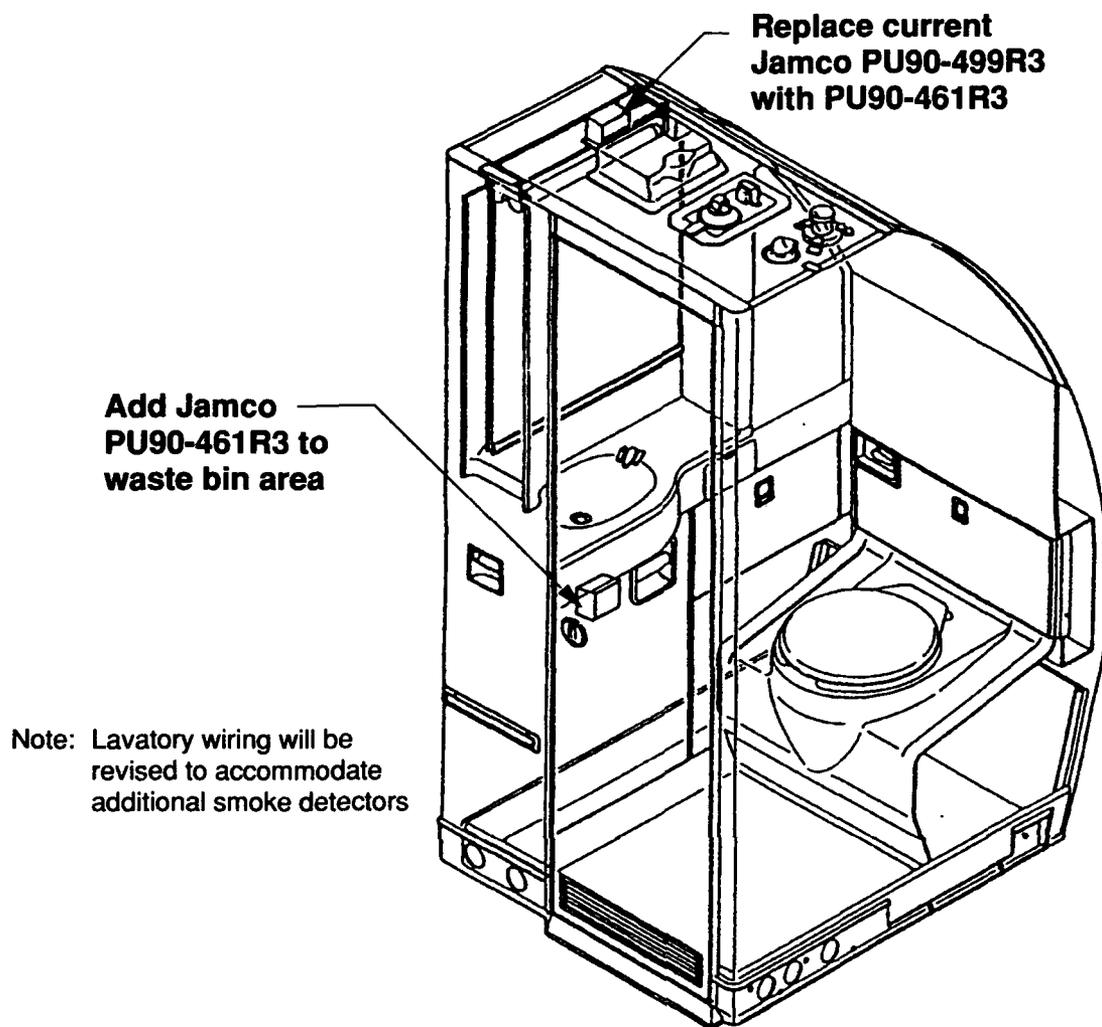

Figure 5-6. Concept A Modifications – Lavatory Features.

The Jamco 461R3 is a dual chamber detection unit that functions as explained in Section 3.2.1. When the two chambers become sufficiently “unbalanced”, as determined by the comparator, the alarm circuit is activated, Figure 5-7. Alarm circuit activation cause the horn integral to the unit to sound, a light to illuminate on all three cabin attendant panels, illuminates a light on the flight deck, and sound a chime over the cabin address system. A reset switch on the cabin attendant panel shuts off the horn and the alert light, and allows monitoring to resume once the area is cleared of smoke.

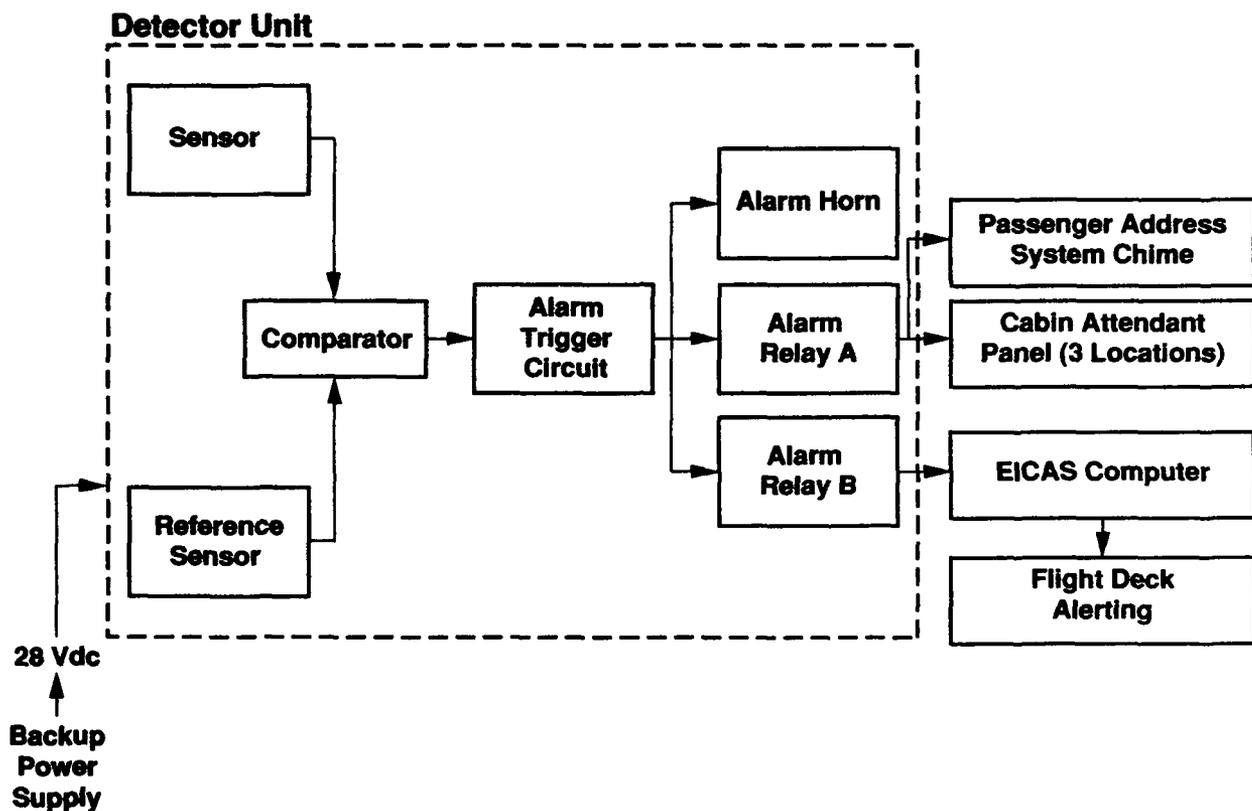

Figure 5-7. Jamco Ionization Smoke Detector PU90-461.

Since the inflight fire on the Air Canada aircraft in 1983 and subsequent FAA ruling, all current Boeing aircraft have current overload protection on the lavatory pump motor. No smoke or fire incidents have occurred since the addition of the FAA-mandated overload protection devices. Therefore, additional smoke detectors behind the toilet shroud was not considered a necessary. On some airplanes, such as the 737, the shroud (tank) area is connected to the cabinet area and the "under-sink counter detector" would detect smoke events that would emanate from the tank motor.

5.3.3 Electronic Equipment Bay

Concept A incorporates the current 757 baseline detection system in the E/E bay without change, except for the use of a LED light source to replace the white light bulb currently in use.

5.3.4 Attic Area

The overhead area on the main passenger deck above the ceiling panel (attic) has been identified as a new area for smoke/fire monitoring. The attic is a large hidden area which has electrical wiring, air ducts, lighting components (ballast), galley exhaust vents, and (on some models) video equipment. In models with retractable clothes closets (not a feature on the 757), an attic detector would be able to monitor the motor used to pull the closet into the attic. Attic sensors become more important on widebody aircraft such as the 747 and 767, both of which have much larger inaccessible areas above the ceiling panels (as compared to a narrow body aircraft).

Six of the Gamewell RT-7 consecutive pulse photoelectric detectors, Figure 5-2, (same as used in the cargo compartment Section 5.3.1), are to be placed equidistant down the length of the airplane in the area above the ceiling liner of the passenger cabin, Figure 5-8. The detectors will be staggered on each side of the main overhead air distribution duct. Provisions will be made in the necessary ceiling panels to allow access to the detection units for maintenance.

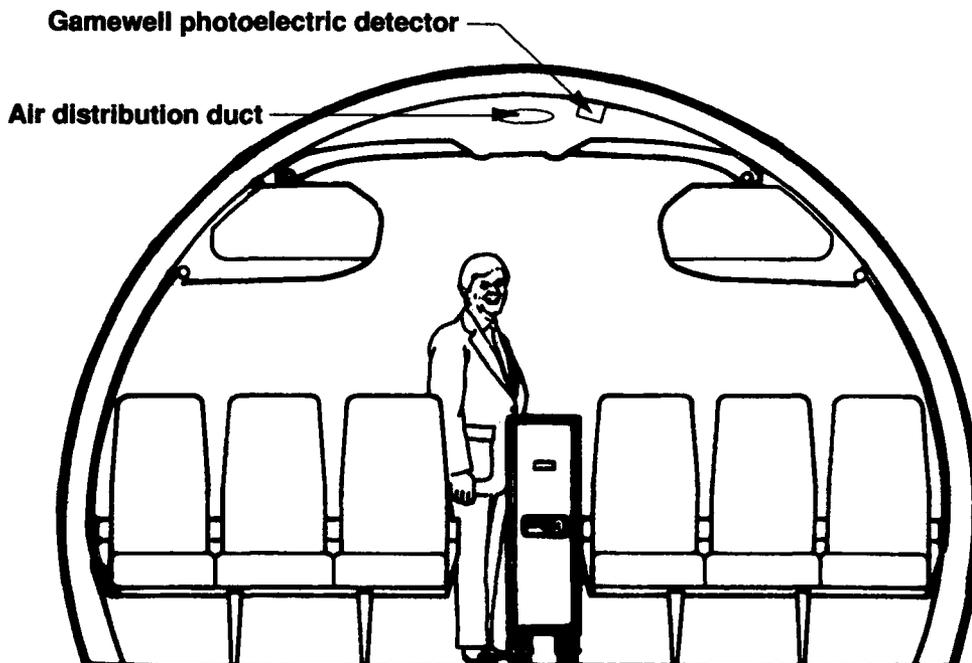

Figure 5-8. Attic Detectors.

The block diagram for the attic detector would be the same as shown in Figure 5-5, without the comparator, as the attic detectors will not be linked with "and" logic. The alarm signal will be relayed to the EICAS computer for alerting the flight deck, to the cabin attendant panels, and a chime will be generated to sound on the passenger address system.

During the course of this study, light ballast units were found to be an identifiable source of smoke in the passenger cabin area and have been subjected to testing for resistance to electrical faults by the FAA Technical Center. Such faults would be detected by the proposed attic detectors.

5.3.5 Air-Conditioning Pack Ducts

Conditioned air discharged from the air-conditioning packs will be monitored for smoke ingestion before reaching the mix manifold, Figure 5-9. This location was selected to expedite pack shutdown, should smoke enter the passenger cabin as a result of an air pack malfunction or contaminated bleed air. With the introduction of air bearings in the air-conditioning pack, the pack shutdown procedure was deleted from the 757 manual. However, other sources (besides bearing failure) such as contaminated/smoky bleed air can result in smoke being delivered to the passenger cabin. Although these events are infrequent, provision to monitor the air exiting the pack was judged to be prudent.

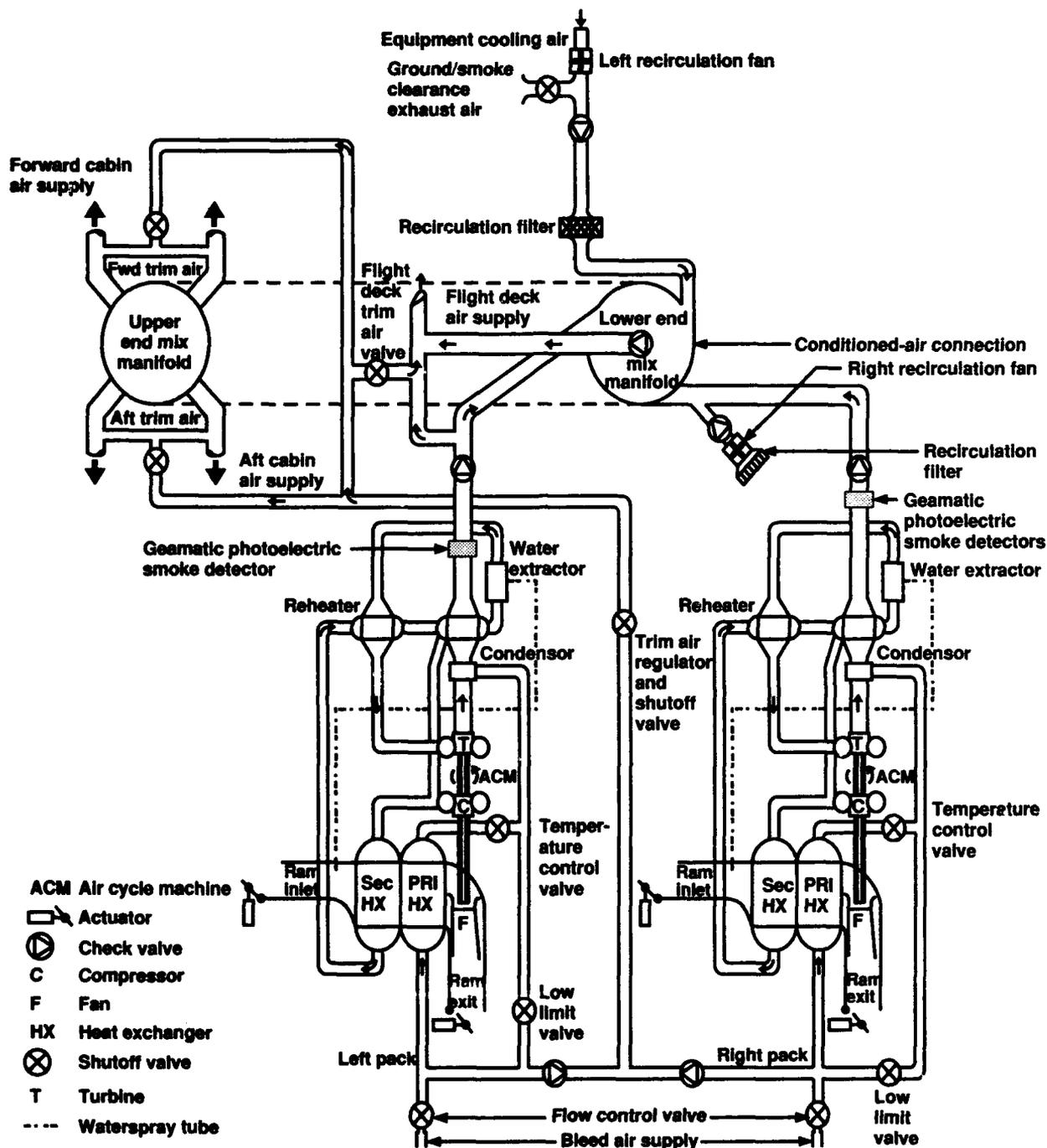

Figure 5-9. Air Conditioning System.

In the older Boeing aircraft (equipped with oiled bearings), the procedure to locate a malfunctioning pack was a process of elimination. The procedure calls for shutting down the right hand pack, then waiting five minutes for the smoke in the cabin to diminish. If the smoke does not subside, the pack is restarted and the left hand pack is shut down. This is time-consuming, and if the left pack is malfunctioning, can allow large quantities of smoke to enter the passenger cabin, creating high levels of anxiety among the passengers.

Geomatic light-attenuation photoelectric duct detectors were selected to monitor the pack air for smoke. The detectors will be mounted as a pair upstream of the mix manifold (Figure 5-9), and linked with "and" logic. An alarm signal, generated when both detectors sense smoke, is sent to the flight deck, allowing pack shutdown procedures to be initiated well before noticeable volumes of smoke enter the aircraft. The Geomatic units self-test for detector cleanliness and a maintenance signal is generated when sensor contamination levels reach set limits. Figure 5-10 shows the block diagram for the conditioned air monitoring system.

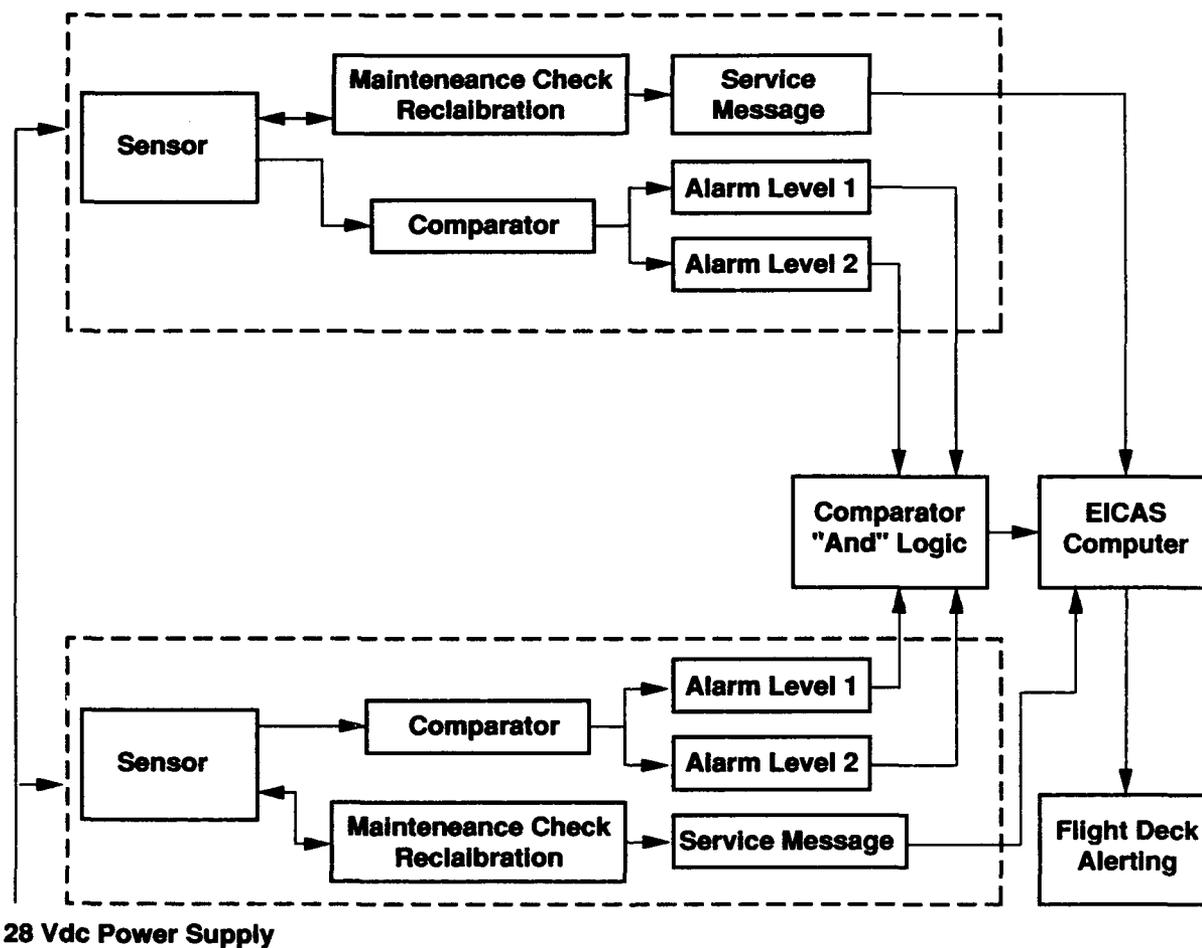

Figure 5-10. Conditioned Air Smoke Detection System.

The installation location for this detector may subject the sensor to water droplets and/or fog depending on humidity conditions. The Geomatics capability to provide reliable monitoring in this area will require additional analysis and testing.

5.3.6 Galley Ceiling

One Jamco detector ionization will be placed in each galley work area, Figure 5-11. The detectors will sense smoke emitted from the front of ovens, carts, storage compartments, and waste containers. The galleys are sealed in the back and any smoke generated from behind the galley will be detected by the attic detectors (Section 5.3.4).

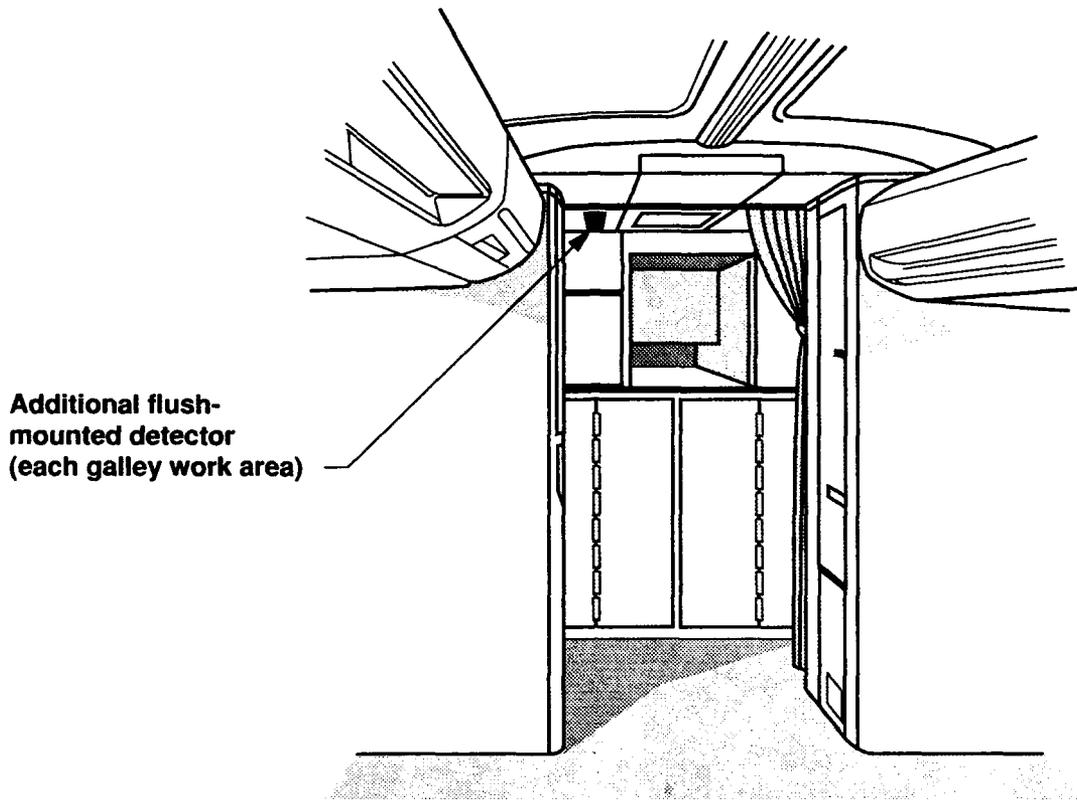

Figure 5-11. Smoke Detector Galley Area Ceiling.

Since each galley detector will be interfaced with the cabin attendants panel and the flight deck, the schematic diagram will be the same as the lavatory detectors, Figure 5-7. Of concern, but which can only be resolved with further analysis and testing, is whether the minor miscellaneous spills, steaming coffee, and other normal galley activities will cause undue alarms during food service preparation. The monitoring of this location may be of greatest benefit for use on long duration flights when the galley area is without activity for extended periods of time.

5.4 SYSTEM REQUIREMENTS

The system requirements for Concept A are the same as for the baseline aircraft and are discussed in Section 3.4.

The Gamewell consecutive pulse photoelectric smoke detector and the Geamatic light attenuation duct detector will require repackaging to meet standards imposed on flight-quality hardware. Certification to FAA standards will be necessary prior to installation on commercial airplanes.

5.4.1 False Alarm Protection

An alarm system that does not provide consistently accurate information would, over time, be treated as a nuisance and the "boy who cried wolf" syndrome results. For safe operation of an aircraft in a smoke/fire situation, it is critical for the flight crew to be able to react with the utmost speed in preparing to divert to the nearest available airport. Such timely action will take place only if a minimum of time is spent in assessing the validity of the alarm. For this reason, false alarm protection will have a high priority in the configuration of the ACES fire alerting system.

The ACES Concept A system provides several means by which to protect against false alarms, especially in the unoccupied/inaccessible areas. Protection is provided by: consecutive pulse photoelectric detectors, self-monitoring photoelectric detectors, and the use of colocated detectors that are then linked with "and" logic. Each of these features are discussed below.

The consecutive pulse false alarm protection feature uses a pulsed LED in a photoelectric configuration, with a rate of one pulse every two seconds. The Gamewell RT-7 detector (Section 5.2.2), which employs the pulsed feature, is slated for use in the cargo compartments and the overhead attic area. To trigger an alarm, the light receiver must have light of sufficient intensity strike it four consecutive times, that is, the receiver must "see" light four times over an interval of eight seconds. For example, if the sensor "sees" an alarm level of particles for three pulses but not in the fourth, the smart base will reset the counter and the procedure will begin anew. This feature is designed to prevent false alarms as a result of a single, light scattering event.

A self-monitoring detector, such as the light attenuation photoelectric unit manufactured by Geamatic, protects against false alarm by checking system cleanliness at a regular interval. The light emitter is boosted to compensate for any contamination on the optic surfaces and the unit continues to operate without either reduced or heightened sensitivity. This feature will reduce or eliminate false alarms due to system contamination. The Geamatic unit generates a maintenance message before the system is completely "blind", allowing the system to be operational without experiencing a blind period, as is the case with some units that must go "out" (blind) before a maintenance message is generated.

The Geamatic detector also provides a two-step analog output. Step one gives an initial signal, while step two requires an increase in smoke density to trigger a second alarm signal. This capability can be utilized by requiring the sensor to "see" both smoke levels before giving an alarm or the lower level signal from both detectors, could be used to generate the alert. This provides additional flexibility for alarm generator, providing false alarm protection over a binary-type sensor.

Collocating detectors provide additional protection and reliability when the detector pairs are linked by "and" logic. This configuration requires both of the detectors to "see" evidence of a fire before an alarm is sent to the flight deck and/or cabin attendant panel. Such a system configuration provides the added advantage of allowing for the system to reconfigure to "or" logic (one detector initiates the alarm) in the event of one of the detectors malfunctioning.

The ACES system is designed to continuously interrogate the sensors to determine their operating condition. For detectors linked with "and" logic, this is essential to ensure that both detectors are indeed functioning. In the "and" logic configuration, if one of the detectors ceases operating, the system can be reconfigured from "and" to "or" logic, and a malfunction, fault message is sent to the maintenance computer.

5.4.2 Wiring

The system wiring is required to be reliable, functionally effective and maintainable. The present standard practices for wire bundle design, fabrication, and installation would support the Concept A system.

5.4.3 System Failure Analysis

A requirement of Concept A is that system reliability be equal to or better than the current system, discussed in Section 3.4.3. Such an analysis cannot be performed until the actual flight quality detectors can be tested (in an accelerated manner) for life cycle mean time between failure (MTBF). Redundant design techniques provide highly reliable systems with minimum dispatch impact.

5.4.4 Sensor Output

Sensor output is discussed in Section 3.4.4.

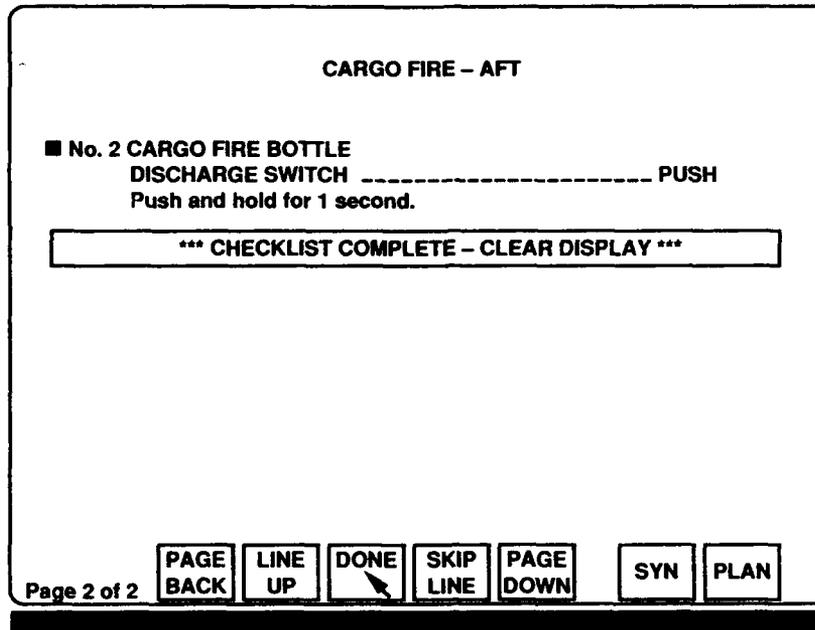

Figure 5-13. Page Two of the Aft Cargo Fire Checklist.

5.5.1.1 Checklist Features

System identification of the specific fault and its location is used to access a checklist that is customized for the particular fault and other prevailing conditions. The checklist itself is pilot-selectable and, depending upon its criticality, may be inhibited during certain phases of flight. For example, the fire bell and master warning lights would be inhibited for fire warnings which occur after gear strut extension on takeoff and before 20 seconds elapsed time or the reaching of 400 feet above ground level (AGL). Caution tones and lights are inhibited after an airspeed of 80 knots is reached on takeoff, and again ending at 20 seconds or 400 feet AGL. The EICAS messages for these alerts function normally however.

The basic design of the checklist will be similar for all alerts that have flight deck procedures. This format provides for the differentiation of the "current" action item, "completed" action items, "incomplete" or skipped action items, and "in-transit" action items (items that have been initiated but whose action has not yet reached completion).

The design of the electronic checklist makes extensive use of color coding to enhance the operation and interpretation of the checklist. The "current" action item is indicated in magenta, with a magenta box around the item (in Figure 5-12, this is the "NO. 2 CARGO FIRE BOTTLE DISCHARGE SWITCH" item). A completed item is shown in green, with a small filled green box shown to the left of the item (the "[AFT] CARGO FIRE SWITCH" item). An in transit item has an open, green box beside it, with the item title remaining white until the action is completed (i.e., the "CARGO FIRE BOTTLE DISCHARGE SWITCH" item). The "ONE PACK CONTROL SELECTOR" item illustrates an item that has been skipped or is incomplete, and these are shown in white. When the other items in the checklist have been completed, the system automatically returns to the incomplete item, which can then be completed or again skipped. Memo (non-action) items are shown in cyan. Figure 5-13 shows the item second page of this checklist. The last item from the first page is shown at the top of the second page in its completed form. The final checklist item is to either accept the "CHECKLIST COMPLETED" (or an "UNCOMPLETE CHECKLIST") message, which clears the checklist from the display, or for Concept B to select the inflight diversion planner (PLAN) or synoptic display (SYN), which will clear the checklist and bring up the desired display.

5.5.1.2 Checklist Operation Interface

A method of interfacing with the electronic checklist must be provided for the crew. While the exact implementation would depend upon the overall information management system on the airplane, several control schemes were reviewed, including: a) dedicated switches mounted on the glareshield; b) a small keyset with cursor control mounted either on the control column, on the seat armrest, or from the forward aislestand; and c) a touch screen mounted on the lower EICAS display. For purposes of demonstrating the features and operation of the ACES concepts, the second alternative was selected. The same basic technique was used for both Concepts A and B.

Checklist items that involve pilot checks not requiring push-button or toggle switch actions are checked off by depressing a "DONE" switch. For the PC-based demonstrations, this switch was used to "complete" all items on the checklist.

Soft switches incorporated at the bottom of the display page also provide the capability to space back or ahead one line item at a time, or to page ahead or back within the checklist.

Provisions for accessing information pages, synoptic, or the inflight diversion planner supplement the performance of the checklist. The provisions for synoptic and the inflight diversion planner, while shown in the figure, are only implemented in Concept B.

Other features of the electronic checklist that would be incorporated include: a) the automatic sensing of switch actions; b) the application of expert systems to checklist customization, c) multiple-fault checklist prioritization; and d) the resolution of conditional ("if") statements. If a system failure prevents the crew from completing the electronic checklist, they revert back to the Quick Reference Handbook.

For functions that are accomplished through switches on systems panels, etc., the signals from the switch closings are also routed to the EICAS computer, that initiates and completes the appropriate coding changes of the items on the checklist display. The crewmember can easily follow the status of the checklist items due to the color and symbolic coding used to reflect checklist item status.

All necessary checklist actions are available on the checklist display page. If the pilot leaves the checklist without completing it, a reminder that the checklist is incomplete is provided on the new display format.

5.5.2 Cabin Attendant Panel

The cabin attendant panel is designed to provide enhanced alerting procedure and tracking of alerts that are the primary responsibility of the cabin attendants. Figure 5-14 depicts the basic layout of the panel and the areas that would initially be illuminated for an "AFT LAVATORY SMOKE" alert. Three separate panels are located in the passenger cabin: at the aft, mid, and forward cabin attendant stations. Layout of the panels is identical at all three locations except for a small triangular symbol which indicates panel location (Figure 5-14 shows an aft panel location).

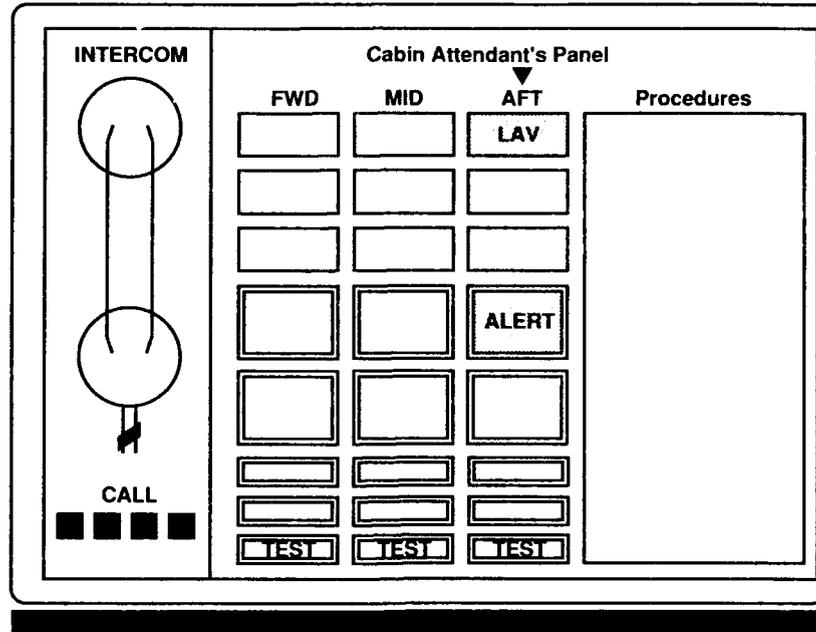

**Figure 5-14. Cabin Attendant Panel –
Aft Lavatory Smoke Alert.**

5.5.2.1 Panel Features

The alert indicators and control switches are arranged in separate columns labeled "FWD", "MID", and "AFT". While this results in a higher overall number of indicators and switches than would be absolutely necessary, it was felt that the redundancy provided in indicating the location of the event, and the circuit separation, were valuable assets in the design of this panel.

The function of the cabin attendants panel is to provide a point source of information in the cabin that will provide the type and location of the sensor alert and both a verbal and nonverbal communications link to the flight deck.

If the alert is the primary responsibility of the cabin attendants, the alert signal will bring up the alerting indicators and warning tone on the cabin attendant panel, with lights indicating both the urgency and the location of the event. The alert is simultaneously sent to the flight deck and displayed on the upper EICAS screen.

5.5.2.2 Panel Operation

The top three indicator segments in any column designate whether the smoke/fire event is located in the corresponding lavatory, galley, or passenger cabin attic. If the event has reached the alarm condition, the appropriate "LAV", "GALLEY", or "ATTIC" indicator illuminates red, along with the associated "ALERT" switch-indicator.

The cabin attendant will initially respond by pressing the illuminated "ALERT" indicator, sending a "responding" message to the flight deck. During or after attending to the smoke/fire event, the attendant can clear/reset the panel by pressing the "CLEAR/RESET" button, that is a readable, but non-illuminated button until the "ALERT" button is pressed, at which time it illuminates with a blue background (Figure 5-15). This status information could be relayed to the flight deck by pressing the "CLEAR/RESET" button, or by talking to the flight deck over the handset phone that will be adjacent to the cabin attendant panel.

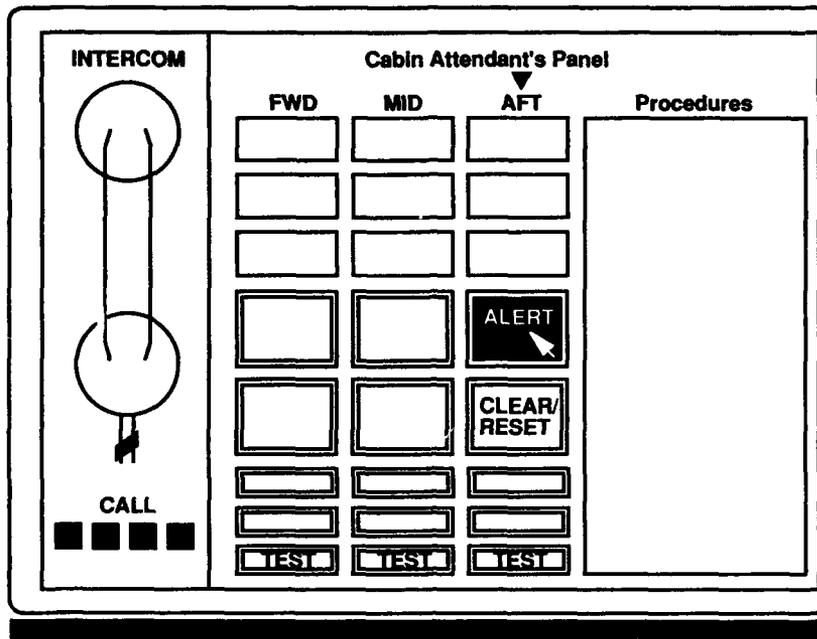

Figure 5-15. Cabin Attendant Panel – After Attendant Response

There are three switch-indicator light segments located below the “CLEAR/RESET” switch-indicator in each column. The first of these is a “DISCH” lamp for any extinguishing bottles that may be a built-in part of the lavatory, galley, or attic smoke/fire extinguishing systems. If a bottle has been discharged, the lamp will illuminate with a blue (advisory) background. Pressing the “DISCH” indicator-switch will cause the area(s) where the discharged bottle is located to illuminate (lavatory, galley, or attic).

The second indicator is a “FAULT” button which will illuminate (also in blue) if any detector circuit is determined to be faulty. As with the “DISCH” indicator, pressing it will illuminate the affected area.

The third switch is a lamp “TEST” switch to checkout the operation of the panel. Depressing the switch will cause all operating panel indicators (for that column) to illuminate. Figure 5-16 illustrates operation of the “TEST” switch-indicator.

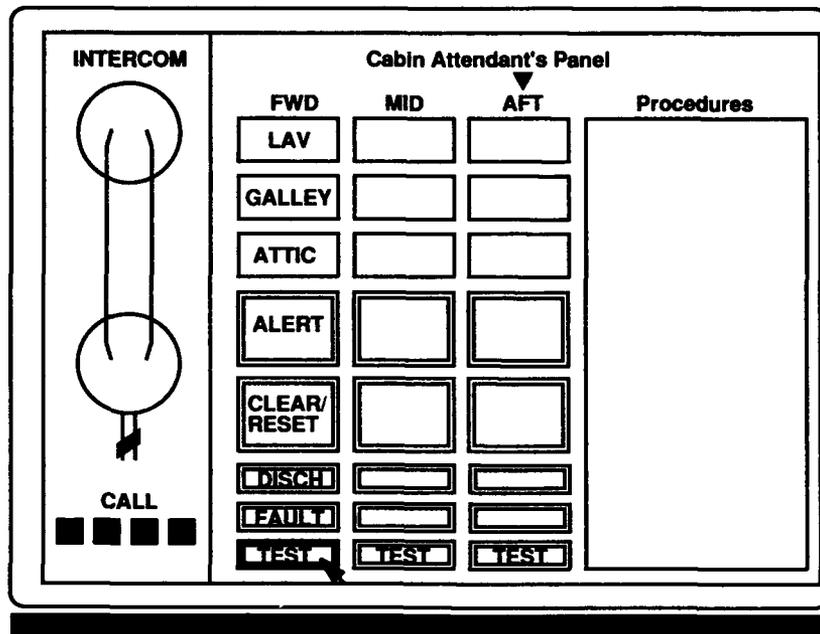

Figure 5-16. Cabin Attendant Panel – Circuit/Lamp Test.

Cabin attendant procedures (checklists) will be presented on printed flip cards on the panel, in a format that can be periodically updated if procedures are upgraded or modified. A changeable card system for the several checklists will be employed at these stations. For the Phase I concept definition study, and Phase II prototype hardware development, the attendants panel will be simulated on a PC-based system.

5.5.3 Data Management

The 757 EICAS computer, that will host the algorithms and display formatting associated with the ACES concepts, is currently “full” (no additional storage capacity is available at this time). It has therefore been assumed, for the purposes of the ACES study contract, that a larger computer would be in place on future 757's before consideration could be given to the incorporation of the processing and display features needed in the ACES concepts. Since a larger computer would be needed for both Concepts A and B, this aspect is not considered a factor in comparative evaluations of the two concepts.

With a larger computer, it is also anticipated that the data bus would be upgraded from the current ARINC 429 bus to a bidirectional ARINC 629 (DATAC) bus. The remainder of the display hardware is assumed to be unchanged from the current set found in the avionics suite of the 757-200.

The basic display generation capability of the 757-200 avionics suite will be utilized to support Concept A requirements. The major changes consist of the addition of several alert messages to the alert display portion of the upper EICAS and addition of the format structure for the electronic checklist.

5.6 CREW PROCEDURES

Concept A results in new areas being monitored for smoke/fire events. As such, new and expanded procedures and training need to be developed and/or refined to reflect the capabilities of an ACES system. Although exact procedures can not be fully developed without a working test system, some of the basic procedures can be commented on. As has been stated in earlier sections of this report, the guiding philosophy is to keep the pilot in the loop, that is, only the flight deck can initiate actions to shut down or reconfigure equipment.

Responsibility for fire fighting duties fall into two categories, those for which the primary responsibility lies with the two-man flight deck crew and those with the cabin attendants.

The flight deck has primary responsibility for smoke/fire events in the cargo compartments, E/E bay, and the air-conditioning system. The procedures currently in place for smoke/fire events in the cargo compartments and the E/E bay will not be changed. These procedures will be displayed to the flight deck crew via the electronic checklist (Section 5.5.1), displayed on the lower EICAS screen. A smoke alert occurring in the air-conditioning monitoring system will require new crew procedures. These procedures, to be displayed via the electronic checklist, are seen to be:

- a) Shut down the faulted (left or right) pack.
- b) Command the remaining (left or right) pack to high flow configuration.
- c) Command recirculating fans off.
- d) Institute diversion procedures (if deemed by flight deck to be warranted).

The flight deck will also be made aware of all alarms being generated by the lavatory, galley, and attic detectors. The flight deck will not actively participate in fighting the fire nor would the two-man flight deck crew be involved in visually accessing the situation. The procedures to be initiated from the flight deck may include:

- a) Pulling the circuit breakers to shut down electrical power to the affected lavatory or galley complex.
- b) For an attic alert the circuit breakers to be pulled would be those to non-essential overhead electrical equipment and lighting, such as interior ceiling lighting, sidewall lights, passenger service units, and in some configurations video equipment and retractable closet motors.
- c) Institute diversion procedures (if deemed by flight deck to be warranted).

The cabin attendants have the primary fire fighting responsibilities for smoke/fire events that occur in the lavatory, galley, and attic. In these areas the cabin attendants procedures would involve pushing the button/switch on the cabin attendants panel to provide the flight deck (non-verbally) that the alert is being investigated. The attendants then have at their disposal both halon and water filled fire extinguishers with which to fight a fire. Upon reacting to and investigating the alarm a cabin attendant would establish verbal contact with the flight deck via the handset (colocated with the cabin attendant panel) to apprise the flight deck of the situation. Depending on the situation the cabin attendants may elect to placard close the lavatory or shut down the galley complex. An incident in the attic may require that halon be discharged into the space above the ceiling via a hand held extinguisher equipped with a wand to enable the ceiling panel to be penetrated.

Crew training (flight deck and cabin attendant) to incorporate the new and/or expanded procedures will be necessary to maximize the benefits of a ACES system. The training must emphasize communications between the flight deck and the cabin attendants. Clear and concise communications are necessary in providing timely resolution of smoke/fire incidents. The time and resources that need to be committed, by both the airframe manufacturer and the operating airline, to make the flight crews proficient in the use of an ACES system can not be estimated at this time.

5.7 SYSTEM INSTALLATION COST

An installation and cost matrix for each of the two concepts has been prepared and shown herein as Table 5-2. The cost matrix is composed of several components: nonrecurring cost which consists of engineering for design and development of ACES systems, fabrication and installation drawings, avionic software and flight deck changes, certification and flight testing, manufacturing tooling design and development, tooling fabrication, and mock-up for form and fit.

Table 5-2. ACES Production Estimate.

Labor	Concept A	Concept B	
		Schlumber	York
Installation & Fabrication			
Initial Design	\$0.47	\$0.91	\$0.93
Sustaining	\$4.00	\$6.12	\$6.30
Engineering			
Initial Design	\$3.10	\$5.51	\$5.51
Sustaining	\$1.13	\$1.45	\$1.45
Total			
Initial Design	\$3.57	\$6.42	\$6.44
Sustaining	\$5.13	\$7.57	\$7.75
Total	\$8.70	\$13.99	\$14.19
Flight Test	\$0.50	\$0.80	\$0.80
Total Labor Cost	\$9.20	\$14.79	\$14.99
Material			
Detectors	\$2.26	\$3.04	\$3.04
System Cost (@ 100K each)		\$20.00	\$20.00
Total Material Cost	\$2.26	\$23.04	\$23.04
Total Cost (1)	\$11.46	\$37.83	\$38.03
Average per ship set	\$57,300	\$189,150	\$190,150

Note 1: 1990 dollars in millions

Recurring costs include repeated manufacturing operations for systems installations, engineering support of manufacturing for initial implementation and sustaining support, material (detectors, sensors, wiring, and related hardware) necessary for installation in the 757-200, and functional test required for delivery and certification. Two columns are listed under Concept B to denote that two different thermal sensors were evaluated for this application.

Basic to the cost estimates is the assumption that ACES installation would occur as a block change on current production aircraft and not as a retrofit package to aircraft currently in service. Integration costs for retrofit installations would be substantially higher and are not included in these estimates.

The cost of each of the two respective systems is presented and discussed in Sections 5.7.2 (Concept A) and 6.7.2 (Concept B).

5.7.1 Component/Subsystem Quantity/Cost

The total quantity of each type of detector required for Concept A and the unit cost for each is listed in Table 5-1. In some instances, the unit cost was estimated for those units that are not available as flight-qualified hardware. Prices for the individual components will vary and depend on the quantities ordered.

5.7.2 Installation Cost Impact

The total cost for implementation of an ACES Concept A system is estimated to be \$11,460,000 for a production run of 200 aircraft. This includes all development labor for engineering and tooling fabrication,

recurring costs for labor and materials necessary to support the systems installations, and any support from engineering. These costs would then, on a single shipset, average approximately \$57,300, excluding any fee or contingency factors. The cost breakdown for Concept A is referenced in Table 5-2.

6. CONCEPT B

6.1 GENERAL DESCRIPTION

The ACES Concept B incorporates all of the detection capabilities described in Concept A, with modifications, and adds additional features that are unique.

Concept B will change the consecutive pulse photoelectric detectors of Concept A to photoelectric detectors that have full analog output to provide the capability to trend-monitor smoke events. Analog output in conjunction with interrogation software should virtually eliminate false alarms, thus increasing flight deck confidence in the system. A thermal detection and monitoring system has been considered and proposed for monitoring the cargo compartments and hidden areas. Two types of thermal detectors have been researched and will be discussed in detail herein. These sensors would be used to monitor the temperature conditions after an event has occurred. Monitoring of thermal conditions might negate the necessity for an emergency evacuation procedures once the aircraft has landed, and reduce the possibility of passenger injuries. Thermal detection is not usually considered a candidate for a primary sensor because of the time required for the air temperature to rise to a point above the set threshold temperatures. Threshold temperatures would require a large range of values to accommodate the temperatures the cargo compartment experiences, i.e., cruise altitude to runway temperature. Monitoring changes in outside air temperature versus changes in sensor temperature would negate some of the problem with temperature transients.

Under certain test conditions, such as alcohol fires, thermal detectors have been shown to respond faster than photoelectric detectors. Further testing under actual cargo/load conditions would be warranted to verify thermal detection systems as primary sources of detection.

Once an alert is sounded, an electronic checklist with the correct procedure can be implemented. The checklist will track the sequence of steps to be followed on the flight deck and confirm completion of these steps.

An inflight diversion planner will provide information to the flight deck that will significantly lessen both the time and crew workload required to divert to an alternate airport. Local airports along the planned flight path, pertinent information such as; runway conditions, emergency equipment, and flying time are displayed on a moving route map.

A block diagram of the Concept B system showing areas monitored for smoke/fire events, locations to which sensor output is directed, flight deck/cabin attendant communications, and suppression capability, is illustrated in Figure 6-1.

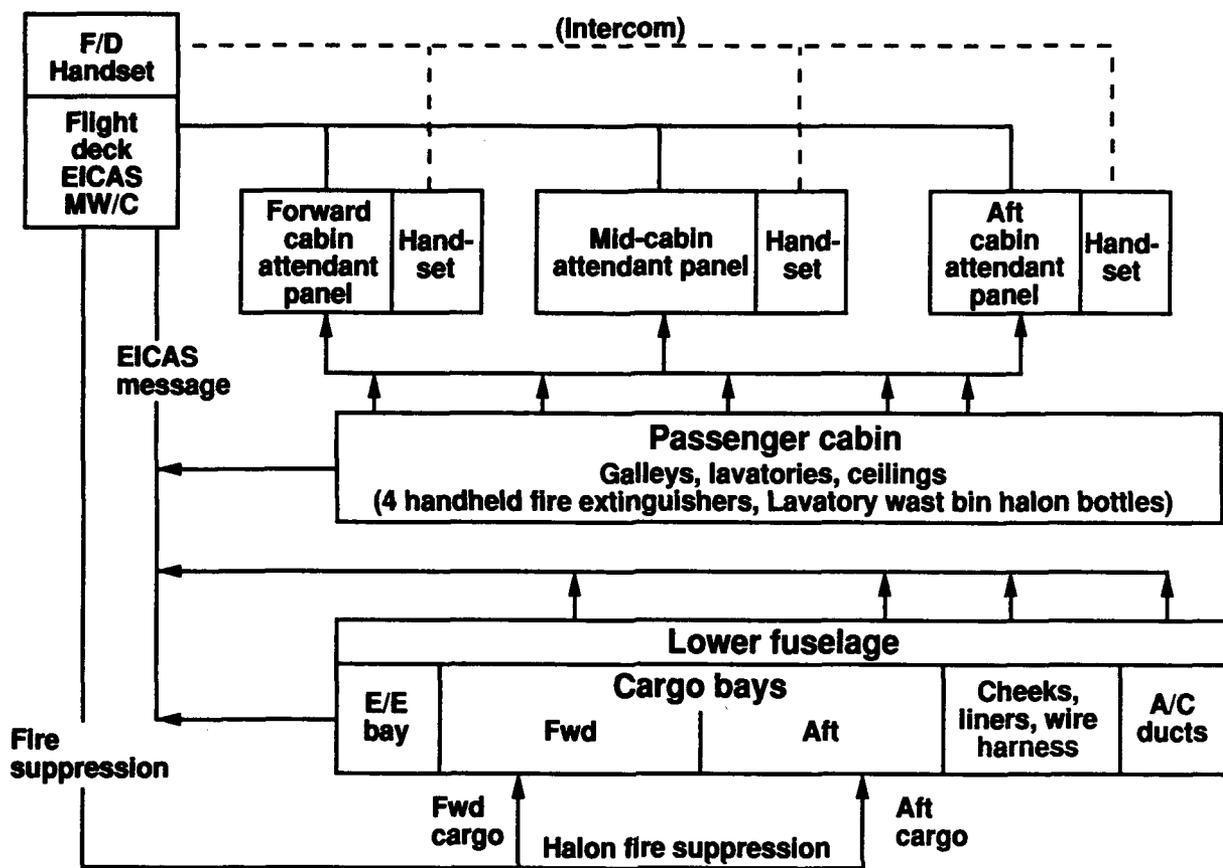

Figure 6-1. ACES Concept B.

6.2 DETECTOR TYPES

Two new detectors are introduced in the Concept B system; continuous thermal monitoring in hidden areas and analog photoelectric in the cargo compartment and attic. The component cost of the detection system defined for Concept B is listed in Table 6-1.

Table 6-1. Concept B Component Costs.

Locations Monitored	Units	Unit Costs	Costs	Type-Manufacturer	Part No.
Smoke detectors					
Cargo/lower lobe					
Fwd (1, 5)	2	\$600	\$1,200	Photoelectric - Fike	63-014
Aft (1, 5)	2	\$600	\$1,200	Photoelectric - Fike	63-014
Lavatory					
Ceiling (4)	4	\$225	\$900	Ionization - Jamco	PU90-461R3
Under counter (4)	4	\$225	\$900	Ionization - Jamco	PU90-461R3
Forward E/E bay					
Supply air (1)	2	\$788	\$1,576	Photoelectric - Autronics	2156-204
Exhaust Air	1	\$788	\$788	Photoelectric - Autronics	2156-204
Galley					
Ceiling (4, 5)	4	\$225	\$900	Ionization - Jamco	PU90-461R3
Passenger area					
Attic (4, 5)	6	\$600	\$3,600	Photoelectric - Fike	63-014
A/C (1, 2, 5)	4	\$1,030	\$4,120	Photoelectric - Geamatic	SDS-300A
Thermal Detection (3)					
Cargo/Lower Lobe					
Fwd	1 wire				
Aft	1 wire				
Cheek	2 wires				
Passenger area					
Attic	1 wire				
Wire runs	5		\$100,000 (6)	Note 3	TBD
Total	34		\$115,184		

Note 1: Installed as pairs with "and" logic

Note 2: Conditioned air upstream of the mix manifold

Note 3: Acoustic thermal detector (Schlumber) or fiber optic (York)

Note 4: Connected to the flight deck/cabin communications panel

Note 5: Estimated, not flight-qualified hardware in current commercial configuration

Note 6: Total estimated cost for a 5 wire run system

6.2.1 Ionization

Concept B will use the same ionization detectors as identified for Concept A, Section 5.2.1. The sensitive ionization detectors (incipient stage of the fire) are intended for use only in areas where the cabin attendants have quick and ready access: lavatories and galley areas. Jamco detectors (P/N PU90-461R3) are to be used, with the alarm signal sent to the cabin attendant panels and to the flight deck.

6.2.2 Photoelectric

An analog photoelectric smoke sensor manufactured by Fike, P/N 63-014 (Reference 17), will replace the Gamewell detectors that were identified for use in the attic and cargo volumes in Concept A. The Fike detector transmits an analog value proportional to the percentage of obscuration measured by the sensor. The sensor has built-in calibration and test circuitry. In its commercial application, a sensor array is linked by the Fike Intelli-Scan panel, a microprocessor control panel, that monitors the sensor network. The control panel is the "brains" of the system, interpreting the signals which are received from the sensors.

The sensor chamber, Figure 6-2, contains a carefully calibrated test LED that is remotely activated by the control panel to accurately measure the quiescent condition of the sensor. During calibration, an analog calibration value is sent and stored in the panel. The calibration value is used by the panel as a reference baseline by which to measure the sensor signal and monitor the unit for maintenance. The control panel allows each individual sensor to be set to alarm at different levels, allowing the level of obscuration to initiate an alarm to be custom tailored to the environment.

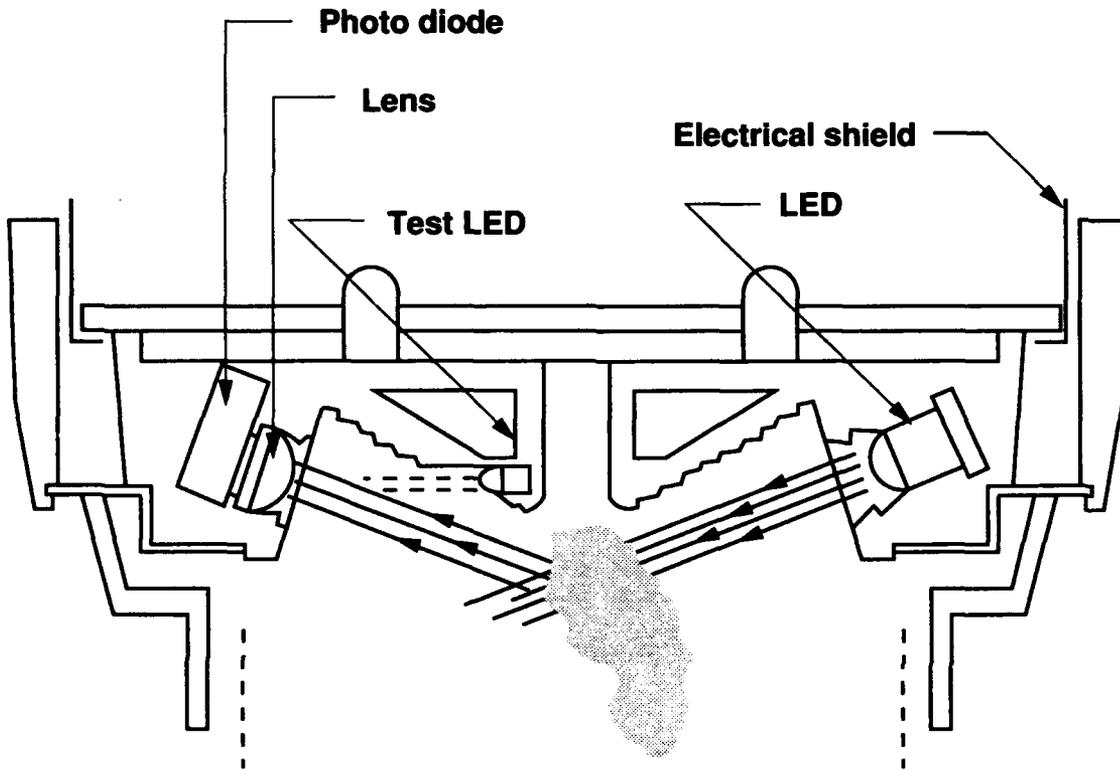

Figure 6-2. Fike Analog Photoelectric Detector.

The Fike sensor is not flight qualified at this time, but there is nothing inherent in the technology to preclude the manufacturing of a unit that would meet flight specifications.

The electro-optic box contains the laser light sources, optical systems for launching eye-safe light levels into the fiber, the optical detection system, and electronic signal processing to analyze the light returning from the fiber. Each box can currently "run" and process the data on up to four fiber loops. Growth of the system to more than four loops is not beyond the current technology. Expansion would require greater processing capability and reconfiguration of the optical front end. Each fiber loop can be up to 2-km in length. The interrogation time is 12 seconds per loop for a 2-km length of fiber, allowing a four-loop system (8-km of fiber) to be evaluated once every 48 seconds. Upon detection of a thermal abnormality the effected, loop would be repeatedly interrogated, allowing the loop to be questioned 5 times in one minute.

The fiber-optic (DTS) system utilizes the scattering properties of pulsed light to determine temperature. As the light passes through the commercial multimode optical fiber cable, Raleigh scattering occurs, a phenomenon in which light is reflected equally in all directions. Thus, some of the light is directed back down the fiber to an optical coupler and then to the signal processing unit. The approach is to modulate the scattering loss coefficient by temperature; the Raman component (anti-Stokes) is particularly sensitive to temperature along the fiber. As the temperature of the fiber rises, the amount of Raman-scattered light increases. Fiber losses are negated by transmitting the lased pulse from each end of the fiber, canceling the noise components of the signal. Pulsing both ends of the fiber also serves to make the system insensitive to breaks in the fiber, as the information on either side of the break is still available.

Currently, the spatial resolution of the York system is on the order of 7.5m (25 ft), although, in conversations with York, the impression was given that a finer resolution was to be available in the near future. To obtain a finer resolution, the optic fiber is coiled on a spool, enabling the spatial resolution to be reduced to about 4 cm, allowing for point monitoring.

6.2.3.2 Acoustic

A continuous thermal monitoring system, using an acoustic technology, has been identified. The system, manufactured by Schlumberger (Reference 19), is similar to the fiber optic system in that a pulse is initiated and the returned signal provides information that is processed to establish thermal environmental conditions.

The acoustic system is comprised of three components: a solid steel-alloy wire, a transceiver, and a control unit. Figure 6-4 shows the sensor wire, transceiver, and the wire support clips. A broadband ultrasonic pulse is sent down the wire and reflected back to the transceiver. Variations in the frequency domain of the reflected pulse are a result of changes in temperature of the wire.

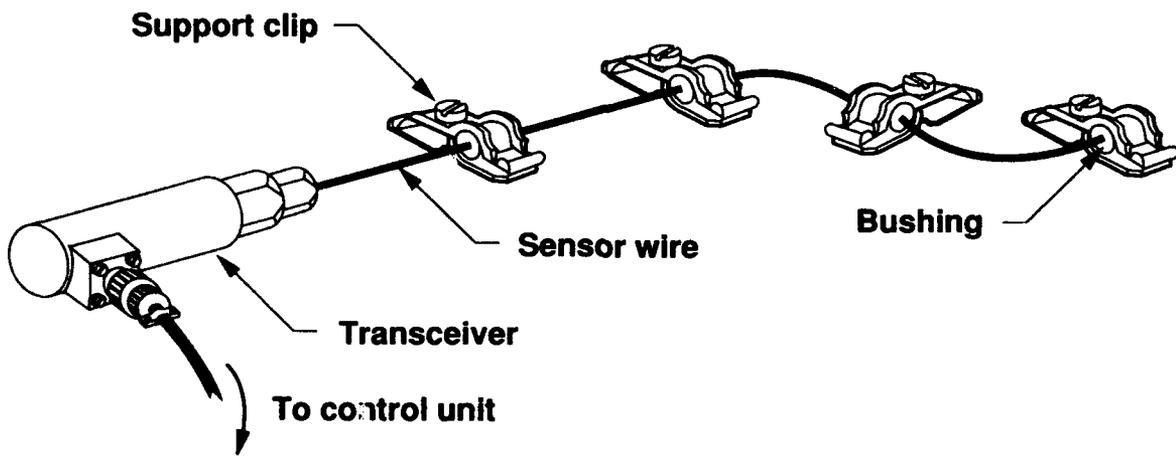

Figure 6-4. Schlumberger Acoustic Thermal Monitoring System.

The sensor wire is a 0.064-in diameter steel-alloy wire, that can be up to 50 ft in length. A 50 ft length of wire can be divided into 8 mechanical zones by coding cut into the wire. Each mechanical zone can be further divided, at the control unit, to provide a spatial resolution of 6 in. The wire currently is restricted to minimum bend radius of 1.2 in. The wire is practically immune to contamination. Support is provided by bushings of composite construction in a quick-release clamp. This clamp/bushing assembly is currently used at Boeing to support the "firewire" used in various areas of the airplane (APU duct, engine).

The transceiver attaches to the sensor wire, energizes the wire with a broadband ultrasonic pulse, and receives the returning signal. The transceiver relays the signal to the control unit where data processing and system evaluation take place. The transceiver, as currently designed, is 1 in diameter by 3 in long and weighs about 0.25 lb.

The control unit is a powerful digital signal processing unit that controls and monitors system operation. The control unit has the capability to divide the mechanical zones electronically into finer zones. This allows "hot spots" to be more precisely located. The control unit allows each zone to be programmed for an individual threshold temperature at which to initiate an alarm. This system provides the capability for continuous trend monitoring and data storage.

The Schlumberger acoustic thermal monitoring system has been tested by the propulsion research and development group at Boeing for use as the engine fire/overheat detector. The preliminary assessment is favorable for a high-vibration environment. The initial drawback was that the sensor had to be one continuous wire. This problem was solved by Schlumberger, with the development of an acoustic coupling that would provide for breaks in the wire. The environments that the sensor would be exposed to in the ACES Concept B would be less harsh than the environment it was subjected to by the propulsion testing.

6.3 LOCATIONS MONITORED

All of the areas monitored in the Concept A system are also included for monitoring in Concept B. Thermal monitoring will be used to detect hot spots in the cargo compartment, main deck attic, and the cheek areas in the lower lobe. Monitoring the cheek area extends fire detection capability to a large hidden area located behind the cargo liners.

6.3.1 Cargo Compartments

The forward and aft cargo compartments will be monitored for both smoke and thermal events. This system incorporates all the sensor capabilities of Concept A (photoelectric sensors) with the enhancement of an acoustic thermal detector system. These two methods are discussed as follows:

6.3.1.1 Smoke Detectors

The smoke detectors to be used in the cargo compartment are manufactured by Fike; their operating principles were discussed in Section 6.2.2. The Fike detectors will be substituted for the Gamewell detectors identified for use in Concept A. This detector will also require a recessed housing to hold the sensor and its base above the cargo ceiling liner. A protective grill, of sufficient durability, will protect the sensor from the rough physical environment of the cargo compartment. The detectors will be mounted in pairs and linked with "and" logic, necessitating both sensors to "see" smoke to initiate an alarm.

6.3.1.2 Thermal Detectors

Either of the thermal detectors described in Section 6.2.3 are to be used in Concept B. Each cargo compartment will have a wire/fiber serpentine down the compartment, mounted behind the ceiling panels. The acoustic system has the advantage of rugged construction, while the fiber-optic system would be easier to route in confined areas due to its flexibility.

As mentioned previously, the thermal system can be used as a primary alarm only if the temperature gradients the system can distinguish is of fine enough definition. That is, the wire must be able to detect

6.3.8.1 Pellew Engineering Approach

A South African company, Pellew Engineering (Reference 20), offers a unique approach to the sensing and extinguishing of fires which may occur in cargo freight containers and/or covered pallets. The system is made up of four major elements: the sensor, the connecting hardware, a data processing unit, and a fire suppressant supply.

A quick disconnect fitting is attached to the container/pallet. The container is then continuously monitored for CO by the sensor that is integral to the fitting. The computer compares the CO signal received with a preset alarm level. Should the CO concentration exceed the preset level, a warning is generated and the flight deck is notified via the Master Warning/Caution System. The flight deck can either reset the threshold and retest or command the discharge of a suppressant, such as halon, into the container. The discharge command would serve to open a valve so that only the alarmed container would be flooded with halon. The system is shown in Figure 6-5.

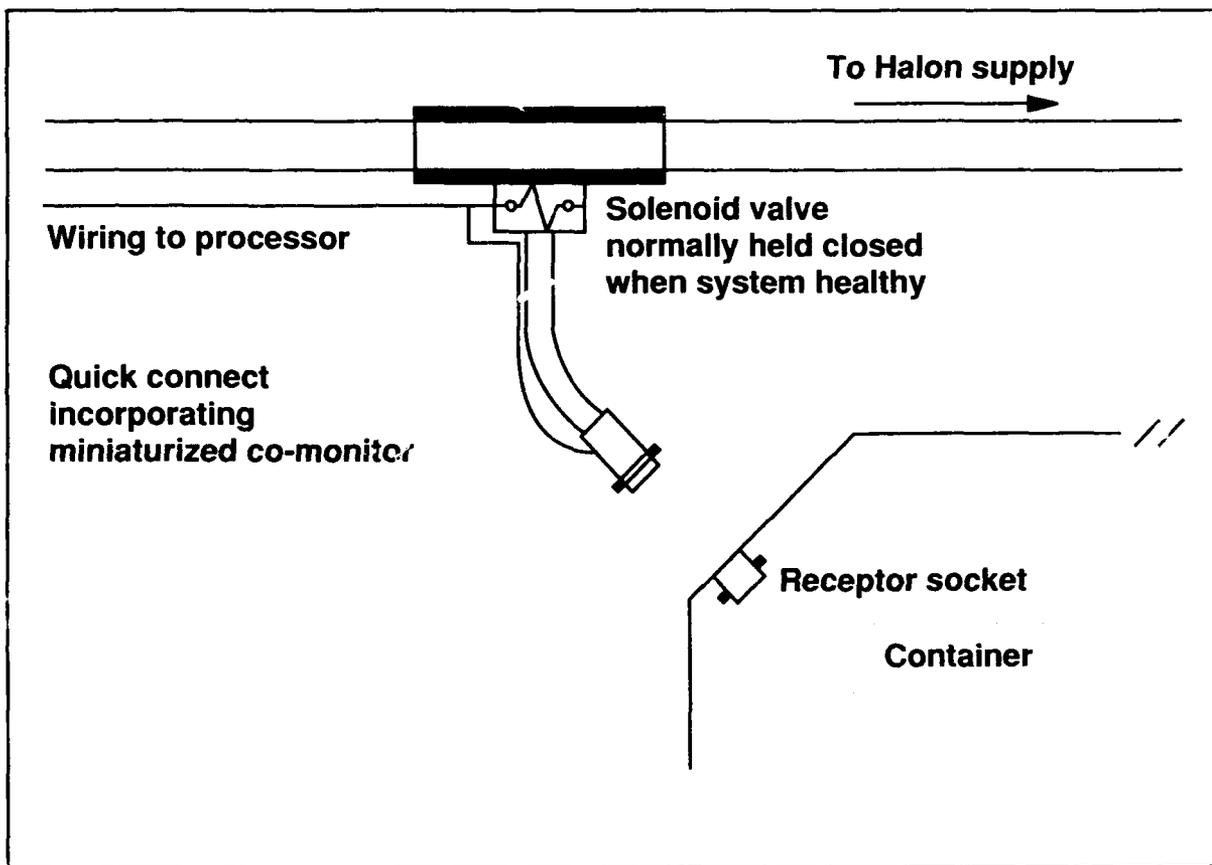

Figure 6-5. Pellew Combi/Freighter Smoke Detection System.

6.3.8.2 Optical

Optical sensors require a line of sight between the sensor and the fire event for detection to occur although weak signals can be detected from reflected light and heat. This requirement is not practical for the variable geometry present in most areas of the airplane. However, this restriction is not as demanding in the high-ceiling area of the main deck cargo compartment of the 747 Combi or Freighter configured aircraft. An optical detector, made by HTL of California (Reference 21), was submitted for consideration for use in this unique compartment. The system is designed to look down onto the top of cargo containers/pallets, with redundant, overlapping view being provided by the use of multiple sensors.

The detector is a thermal imaging module (TIM), Figure 6-6, that has three detection thresholds, each of which is able to generate a fire signal. The three detection methods are as follows:

- a) Primary detection is provided by an infrared optical overheat device
- b) Secondary detection warns of presence of flame signature (infrared radiation)
- c) Tertiary output indicates that the sensor body has exceeded 85°C (185°F)

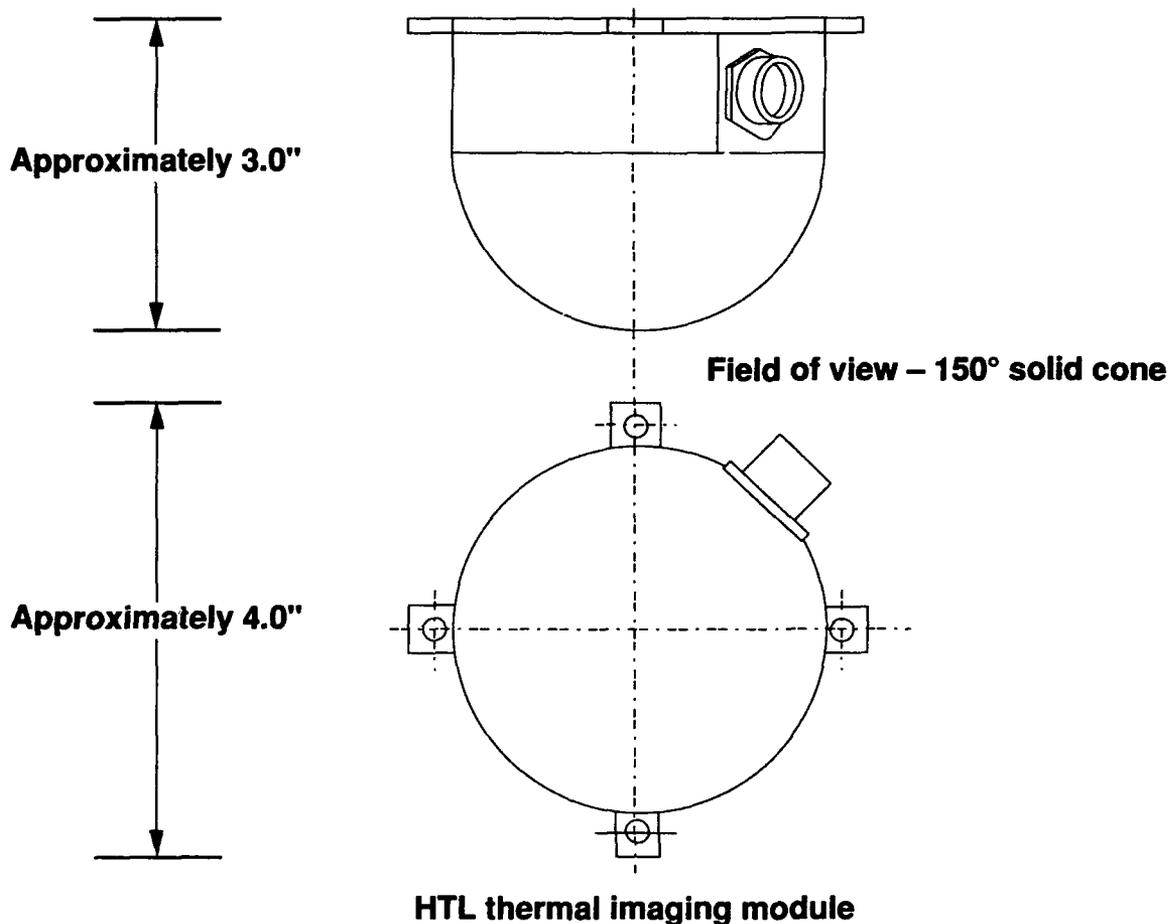

Figure 6-6. Combi/Freighter Main Deck Cargo Bay Fire Protection System.

The optical component of the sensor is designed to rotate at a few revolutions per minute, providing hemispheric coverage over a 24-ft diameter field of view in an empty 747 main deck cargo bay. The detector wavelength was selected to be blind to solar radiation yet retain a high sensitivity to hot body and flame signatures. The sensitivity of the system is 1-ft diameter at 400°F at 17 ft for overheat resolution and a 5-in pan fire at 17-ft for the flame sensor.

Each TIM will be connected to a control module where system fault detection, location logic and alarm signal generation logic will be contained. Each of the sensors has a unique address allowing the event to be identified, as occurring at a given pallet/container location.

6.4 SYSTEM REQUIREMENTS

The system requirements for Concept B are the same as for the baseline aircraft and are discussed in Section 3.4.

The Fike analog photoelectric smoke detector and both of the thermal monitoring systems will require repackaging to meet standards imposed on flight-quality hardware. Certification to FAA standards is necessary prior to installation in commercial airplane service.

6.4.1 False Alarm Protection

Concept B expands on the false alarm protection outlined in Section 5.4.1 for Concept A. The replacement of the Gamewell consecutive pulse photoelectric with the Fike analog photoelectric detector provides an expanded format by which to analyze and display data. The ability to monitor the change in smoke density can be used, with suitable system logic, to further decrease the occurrence of false alarms. With continuous, step function (analog) data available, numerous criteria could be formulated for generating an alarm. How best to use the data available from the sensor can only be known through a testing program, but scenarios can be developed to demonstrate this feature. The analog data could be monitored such that an alarm would not be generated unless the smoke density exceeded a nominal confidence range for a certain time or number of signals over a given period of time. A time delay could also be built into the system so that the initial detection of an alarm level of smoke would be rechecked after a time period to confirm the continued presence of smoke before generating an alarm. The Fike system also allows each sensor to be tailored for its location and environment, further reducing the potential for false alarms.

Thermal monitoring has potential to provide another parameter by which to reduce false alarms. If a thermal system can be shown to be sensitive enough, two parameters, smoke and heat, could be combined as the criteria in generating an alarm. This would be practical only upon rigorous testing of the proposed thermal systems. As previously discussed, large amounts of heat are not generated until the latter, third stage of a fire, Section 4.2; therefore, a thermal system would be required to detect small, localized changes in temperature to be useful as a supporting parameter for the generation of an alarm.

6.4.2 Wiring

The system wiring is required to be reliable, functionally effective and maintainable. The present standard practices for wire bundle design, fabrication, and installation would support the Concept B system.

6.4.3 System Failure Analysis

A requirement of Concept B is that system reliability be equal to or better than the current system, (Section 3.4.3). Such an analysis cannot be performed, with any degree of confidence, until the actual flight quality detectors can be tested (in an accelerated manner) for life cycle mean time between failure (MTBF). Redundant design techniques will provide highly reliable systems with minimum impact on dispatch reliability.

6.4.4 Sensor Output

Sensor output is discussed in Section 3.4.4. With a new computer, the ARINC 429 databus will be updated to DATAC 629.

6.4.5 Built-In Test

BIT functions are discussed in Section 5.4.5.

6.5 FLIGHT DECK DESIGN

The basic ACES design incorporated into Concept A was used as the basis for the design for Concept B. This approach was selected as being more efficient, cost-effective, and resulting in a more highly developed system in Concept B than would have been possible with two equally-competing concepts. From the baseline flight design incorporating the electronic checklist and cabin attendant panel, Concept B enhancements were added, including an inflight diversion planner and a synoptic display capability. Additional enhancements have been made to the basic crew alerting system.

6.5.1 Alerting System Enhancements for Concept B

In addition to the basic alerting system configuration used in Concept A, two enhancements have been included in Concept B. The first is the addition of voice messages for all smoke/fire alerts on the flight deck. These voice messages will mirror the messages on the alert display, providing dual-channel message presentation. The voice message for an alert are activated by the crewmember when the Master Warning/Caution switch-indicator is depressed.

A second enhancement is a minor change to the alert display in which advisories will be represented in cyan instead of amber, and not indented (on the current 757-200 EICAS display, message titles for advisories are displayed in amber characters, with the line indented one space to differentiate them from caution level messages, also coded in amber).

6.5.2 Electronic Checklist and Cabin Attendant Panel

Although a number of the smoke/fire alerts for either Concept A or B may be of the same criticality level (the majority are warnings), many may have slightly different priority levels as to how urgent the situation is. Based upon information received from the sensors and processed by an "intelligent" (rule-based) logic set, each alert can be assigned a priority-level index. This priority index can then be used by the expert system to customize the crew response checklist to obtain the best sequence of actions needed to resolve the alert. In various flight phases or conditions, such as below 500 ft on approach for example, the priority index would inhibit the alert from being initiated until this more critical flight segment was accomplished.

The cabin attendant panel for Concept B is identical to that used for Concept A. No variations in either design or function are recommended for Concept B.

6.5.3 Inflight Diversion Planner

When a serious smoke/fire event occurs when airborne, the proper crew procedures include diverting the aircraft to the nearest suitable airport. Although much of the information needed to make the decision as to which airport to divert to is contained in the Flight Management Computer (FMC) database, it is not necessarily in the best format for making a quick, informed decision. At this critical time, access to the information may be time-consuming, and crew workload may be impacted by the amount and diversity of the information.

For Concept B, a display format and associated software was developed to provide expert system information on the nearest (or "best") available airport, in the event a decision is made to divert. The initial display page for this inflight diversion planner is shown in Figure 6-7.

REPLAN—FIRE EMERGENCY

	ETE	RUNWAY	WEATHER	FACILITY
AIRPORT				
PPG	1+17			⚡
NAN	2+23			
JON	2+47		⚡	⚡
PLA	0+48	⚡		

RETURN
ROUTE SELECT
INPUT
QUERY

Figure 6-7. Inflight Diversion Planner Display Format.

6.5.3.1 Inflight Diversion Planner Functions

The inflight diversion planner function includes estimates of time en route (ETE) to alternate airports, a runway analysis of the available (within range) airports, weather, rescue, and fire fighting facilities that might influence selection of an alternate landing site. The inflight diversion planner display would utilize information currently available in the 757-200 navigation database, but would require additional information on airport facilities.

The initial display format provides the results of the expert system analysis, with a rank-order presentation of the recommended airports that the pilot might divert to, i.e., "PPG", "NAN", and "JON" are, in order, the most attractive alternates, according to the expert system analysis. The airport listed last, "PLA" is the fourth best alternate, but is not recommended, as noted by the different shading used on this airport box.

Three levels of coding are used to differentiate the "goodness" of the various alternates: a) a filled green (white in above figure) box indicates the highest rating; b) a box divided diagonally with one half green and the other half blue (shaded in above figure) represents a middle rating, and c) an all-blue (shaded) box designates the lowest recommended rating. An non-recommended alternate is shown with an amber-filled (black) box.

This same coding scheme is utilized in boxes at the intersections of the airports and the rating factors listed across the top of the display. Thus the pilot can see at a glance how each alternate airport rated on the four factors considered by the expert system. These four factors may each have been assigned different "weights of importance" in the initial setup of the expert system rule-based logic. They are listed, from left to right, in order of this weighting factor, e.g., ETE was given the highest priority of the four factors in the fire emergency scenario.

This analysis process uses the design of a Boeing developed NEXPERT OBJECT expert system shell which coded the rules, hosted the expert knowledge database, and derived the decision-aiding features of the inflight diversion planner. In this Boeing project, an inflight fire scenario was used to develop the rule-based analysis of the relevant factors and to develop the subsequent recommendation of the most suitable alternate airport.

6.5.3.2 Inflight Diversion Planner Operation

Once the flight deck crew completes the checklist for a particular smoke or fire alert, they would normally select the inflight diversion planner format. This functional display can be accessed from a menu item on the bottom of the checklist page. The crew would then evaluate the recommendations of the expert system and select an alternate airport accordingly. If the pilot is unsure about the expert system's recommendation and desires additional supportive information, he/she would be able to exercise additional options of the inflight diversion planner expert system by selecting expanded information on any one of the parameters used in the process of alternative airport selection. Available information for each airport would include details of the evaluations of either: a) estimated time en route; b) weather; c) runway suitability; or d) fire and rescue facilities at each airport. Figure 6-8 shows the display format for weather information that would be selected by "clicking" on the "WEATHER" box on the first page (Figure 6-7) of the inflight diversion planner. The pilot could also select expanded information on any single airport (which would include expanded information on all four factors), or select information on a non-recommended airport if it is closer than the displayed airports. The crew can also query the expert system as to why it made the airport selections it did. Finally, the crew could request a summary of parameter information on the set of recommended airports.

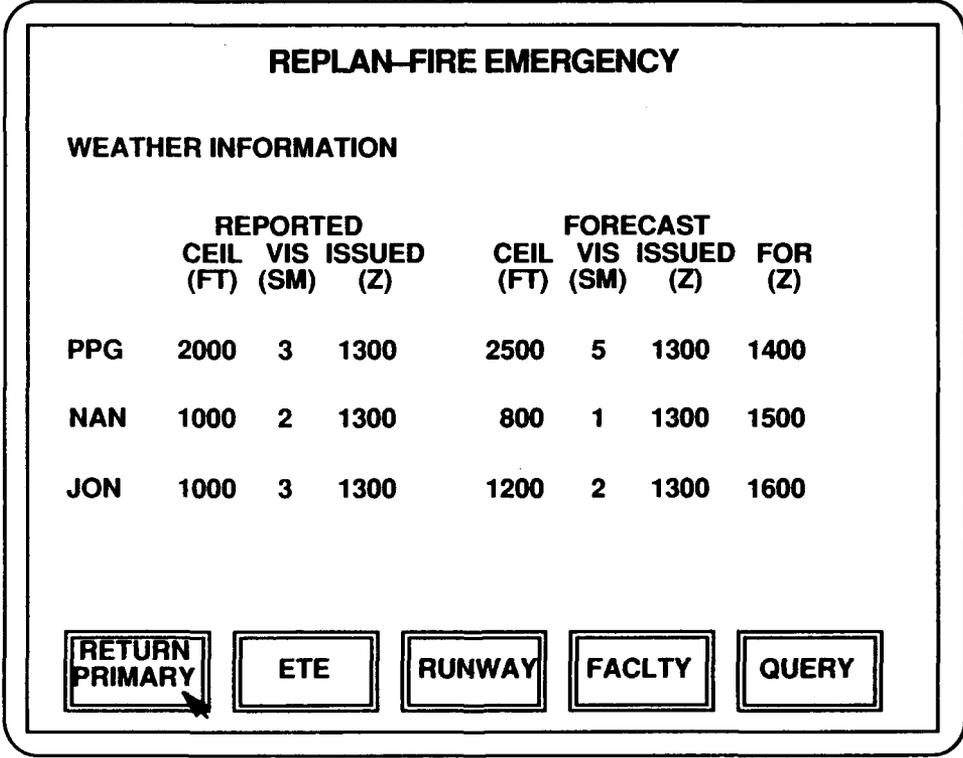

**Figure 6-8. Inflight Diversion Planner Format
for Weather Information.**

When the pilot has selected the desired alternate airport and reprogrammed the airplanes route, he/she might turn next to the synoptic display format to review the latest status of the smoke/fire event.

6.5.4 Synoptic Display Format

As an additional system enhancement under Concept B, the pilot will be able to access synoptic displays for feedback and situational awareness of the progress of the smoke/fire event. Two types of synoptic display pages are available: a) one showing the location and status of each of the ACES system detectors; and b) one showing the signal history of a particular (selected) detector. Both of these are accessible through a menu system on the display. These formats are shown in Figures 6-9 and 6-10, respectively.

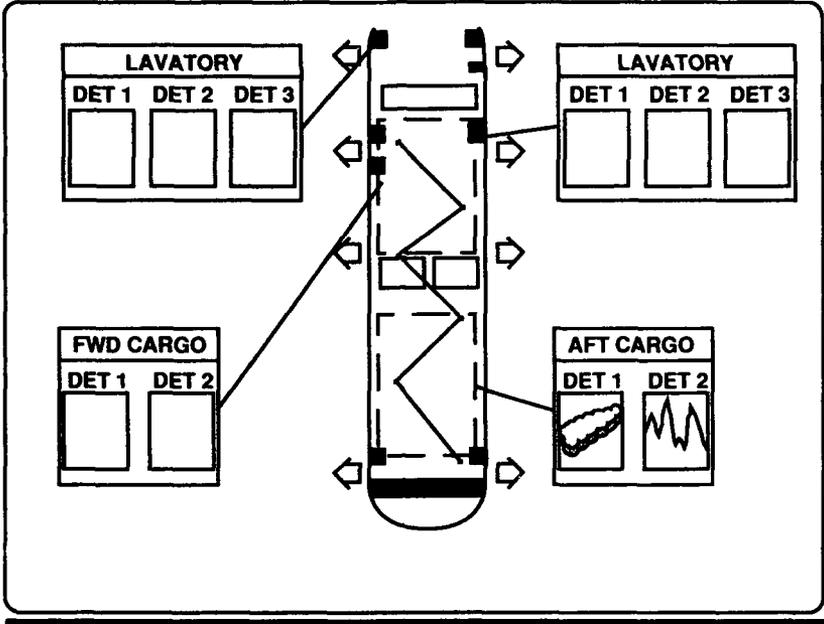

Figure 6-9. Synoptic Display Layout for Concept B.

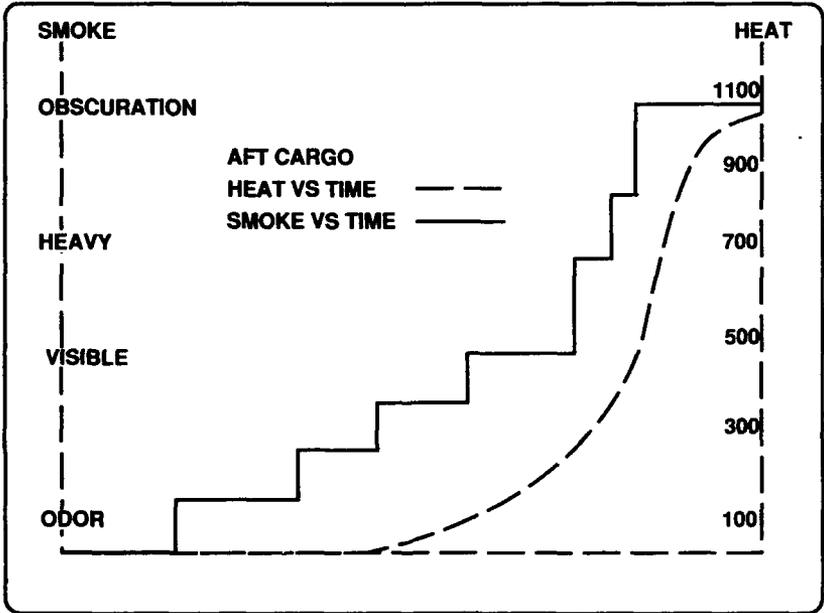

Figure 6-10 Synoptic Display – Sensor Signatures.

would be displayed via the electronic checklist, this may include the shedding of non-essential electrical loads, shut down of recirculation fans, configuring packs to high flow and the use of the inflight diversion planner.

Consideration was given in Concept B to reducing the work load on the flight deck through the automation of some of the crew functions, such as, electronic load shedding, control of recirculation fans, air-conditioning pack flow control, and the activation and discharging of the fire suppressant systems. While such automation is certainly possible, it runs counter to the philosophy of keeping the pilot "in-the-loop", that is the flight deck crew should initiate, if only by pressing a button, commands that shuts down and/or results in system reconfiguration. This philosophy was re-enforced by conversations with flight deck personnel who made it clear that configuration control of the airplane, especially in emergency situations, should reside with the person responsible for landing the airplane.

Coordinated training which includes both flight deck and cabin personnel would greatly enhance effectiveness of the Concept B system. An estimate of the resources and time that would be needed to adequately train the crew to best use the Concept B ACES system is not, at this time, known with any degree of confidence.

6.7 SYSTEM INSTALLATION COST

Concepts A and B installation costs were developed using standard Boeing price/cost estimating methods for developing model change costs. This procedure involved generating a work statement sufficiently defined and detailed that would provide the vehicle by which the various functional organizations, such as Manufacturing, Engineering, and Flight Test, estimate their respective nonrecurring and recurring costs.

Each of the concepts was treated as a model change for "and on" aircraft, that is, for pricing purposes, the concept implementation would start at a particular line position and would continue thereafter. For cost purposes, an assumption was made that the model changes would occur over a production run of 200 airplanes, involving 18 customer configurations. The number of customer changes is based on the actual number of customers for the 757-200 to date. Each of these customers has requirements that are unique to their aircraft, therefore requiring estimates for each configuration. In some instances, such as occur with the flight deck, a change made for one airplane applies to all. Changes which affect the Flight Management System, such as the system software, are extremely expensive and because the software is embedded, a new set of "black" boxes and part numbers must be generated. Table 5-2 presents the production cost estimates for Concept B.

6.7.1 Component/Subsystem Cost Impact

The cost of each of the ACES concept components, sensors, and detectors, was collected from each of the manufacturers or suppliers. Production quantities of the components was, in some cases estimated, with the estimates based on current procurement of comparable hardware. For example, in Concept B where new technology thermal detection systems are proposed, the manufacturers current cost for commercial systems was used with the understanding that repackaging these systems to comply with airborne standards and reliability may drive the cost higher. In that regard, if the system procurement costs were to be twice the estimate used in the cost analysis, the recurring procurement cost would be obviously higher but the effect on the total price spread over time (airplanes) would not be as significant as the amount of labor required for the initial engineering and subsequent recurring labor.

6.7.2 Installation Cost Impact

The implementation cost for Concept B was estimated for two systems: one estimate utilizing the York fiber optic temperature sensing system, and the other utilizing the Schlumberger acoustic wire temperature sensing system. The reason for two estimates is that a relative figure of merit of either system is not available as both are new technology applications. The average cost for implementing the York or Schlumberger system for 200 current production airplanes is \$190,150 and \$189,150, respectively. The detailed cost breakdown for Concept B components is listed in Table 6-1.

7. CONCEPT PERFORMANCE EVALUATIONS

It was originally proposed to conduct comparative evaluations of the two ACES concepts to determine the relative performance merits of them. However, instead of developing two competitive concepts, a more cost-effective approach was taken in which Concept B includes all features and developments of Concept A, as well as incorporating several of its own performance enhancements. Thus, Concept B would naturally be expected to outperform Concept A in any direct comparison. It was therefore determined that a direct comparison, on the basis of performance, would not be a very meaningful measure.

While the ACES concepts will save time in the correct performance of crew/attendant procedures in response to a smoke or fire event, the major and significant benefits of the ACES concepts lie in their ability to detect smoke/fire events earlier, prevent errors in procedures, and to prevent non-productive (wasted) time in the decision-making segments of the response sequence. In order to objectively measure the benefits of the ACES concepts over the baseline configuration, a test would have to be devised in which the crew made a significant number of errors, and consumed inordinate amounts of time in responding to smoke/fire events under the baseline condition. Any such test would be extremely artificial, and perhaps impossible to control or measure adequately.

Therefore, the approach taken for this contract phase was to reanalyze each of the scenarios described in the Dunlap report (Reference 1), to indicate where, and in what way, the two ACES concepts would contribute to a more expedient, error-free crew and attendant response sequence to these events. It was felt that it would be gross speculation, however, to try to attach numbers to time savings, or to the reduction of errors in regards to the benefits of the ACES concepts. Extensive simulator evaluations could provide data on the actual timeliness that could be expected with the two concepts under perfect, or near perfect conditions of crew performance. These data could be used to validate the appropriateness of the application of these concepts to this area of alerting. Reliable conclusions concerning the major potential benefits of the two concepts will probably be better determined from subjective evaluation of past and potential, smoke and fire scenarios, and the anticipated chain of events that might be seen under the two concepts and the non-ACES baseline configuration.

7.1 DUNLAP SCENARIO EVALUATIONS

7.1.1 Scenario No. 1

This scenario involves a widebody three-engine jet airplane with a three-person flight deck crew. A fire started in the aft cargo compartment and was detected approximately fifteen minutes later. The flight crew choose to check the smoke detection system from the flight deck as well as send the flight deck engineer to investigate the incident. There was additional confusion and delay in correctly locating the correct procedures in the flight manual. The confusion in locating the proper procedure was due to the needed procedure being located in the "Emergencies" section of the manual rather the "Abnormal Procedures". The crew initiated a return to airport turn around four minutes after detection, landing about twenty-three minutes after detection or thirty-eight minutes after the start of the fire. The fire continued to burn within the compartment, enveloping the rest of the airplane in smoke, finally totally consuming the entire interior. There were no survivors even though the airplane was landed and stopped at the airport.

7.1.1.1 757 Baseline Airplane

The primary difference between the 757 baseline airplane and the aircraft in this scenario is that the baseline aircraft is designed with Class C cargo compartments, equipped with "and" linked photoelectric smoke detectors, and a halon fire suppression system. One other significant difference is there is no flight engineer on the baseline aircraft, only a two-man flight crew.

In a cargo compartment smoke/fire alert, the smoke detectors would sense the smoke and provide an alert warning to the flight deck. The flight crew would, as in the scenario, interrogate the detection system through the flight deck test panel and consult the flight manual to confirm abnormal or emergency procedures prior to initiating emergency measures. The crew would then respond by discharging the No. 1 fire

suppression bottle, flooding the compartment with halon, maintaining a sufficient concentration to suppress a fire for approximately 80 minutes. The suppression system should provide sufficient time to reach an airport and allow an evacuation of the airplane. The baseline system will minimize the potential for fatalities, although injuries associated with an emergency evacuation are assumed to occur.

7.1.1.2 Concept A

Concept A incorporates two multi-pulsed, "and" linked photoelectric smoke detectors in the cargo compartments and the electronic checklist on the flight deck that will display the emergency procedures for an aft cargo compartment fire alert.

The improved system reliability achieved by integration of the multi-pulsed smoke detector will increase the flight crew confidence in the alerting system, by reducing the potential for false alarms. This increased confidence, coupled with the electronic checklist, should result in an immediate activation of the aft cargo compartment fire procedures, providing several minutes of additional time for diverting to an alternate airport. Upon landing, normal emergency evacuation procedures would be initiated.

Time saved in landing the aircraft safely results from:

- a) Increased confidence in the detection system, thus eliminating time spent rechecking the system and revivifying sensor alerts;
- b) Automatic display of the emergency procedures eliminates the time required to search for the proper procedure.

7.1.1.3 Concept B

The Concept B airplane has the detection capability of Concept A detection system but incorporates dual "and" linked analog smoke detectors and a thermal detection in the cargo compartment. The flight deck capabilities are significantly increased with the addition of an inflight diversion planner and synoptic display.

The scenario response for Concept B would be similar to that of Concept A. The flight deck will realize additional confidence in the system due to the added reliability of analog output detection devices that reduce the potential for false alarms associated with discrete output detectors. Implementation of the electronic checklist will assure the completion of the correct cargo fire procedures. The inflight diversion planner will be used to confirm that landing at an alternate airport is the most expedient option for the flight crew. Additional information will be provided on the selected airports, weather, runway, field conditions and emergency capabilities.

The thermal and smoke environment of the aft cargo compartment could be monitored on the flight deck using the synoptic display should sufficient time be available. Monitoring would be of value for early detection of possible re-ignition and the decision to discharge halon bottle No. 2. Early discharge is unlikely, but a damaged cargo liner may not contain the halon at suppressions levels for the full 80 minutes. Upon landing, if the cargo compartment temperature monitor indicated the lack of a hazard, an emergency evacuation could be performed in a orderly/controlled manner, or even avoided altogether, reducing the potential for injuries to passengers and crew.

Time saved in landing the aircraft safely results from:

- a) Increased capabilities of the detection system;
- b) Automatic display of the proper emergency procedures;
- c) Inflight diversion planner in locating the nearest suitable airport;
- d) Monitoring conditions with synoptic display capability.

7.1.2 Scenario No. 2

This scenario involves a narrow-body, two-engine jet airplane with a two-person flight deck crew. A fire started in the area of the aft lavatory and spread behind the interior panels (an area not covered by detectors or accessible for extinguishing). The fire was detected approximately nineteen minutes after ignition and the airplane diverted eight minutes after detection. Fire fighting started soon after detection, but had little effect. The airplane landed twenty-two minutes after the fire was detected and an evacuation was started immediately. Flashover, as a result of excessive heat buildup, consumed the cabin before everyone was evacuated.

7.1.2.1 757 Baseline Airplane

The 757 baseline airplane is different from the scenario airplane in that it is equipped with lavatory smoke detectors, flush motor overheat protection, interiors incorporating stringent flammability materials, and lavatory trash bins that have auto-discharge halon extinguishers. Additionally, as a result of several lavatory smoke/fire incidents, crew duties are now more clearly defined for this type of emergency.

The first indication of an electrical problem would be tripping of circuit breakers, followed by the lavatory smoke detectors sounding as the smoke entered the lavatory. This system might possibly provide a fire warning about ten minutes before smoke would be noticed outside the lavatory. The cabin crew would initiate fire fighting procedures and provide the flight deck with an assessment. The flight deck would not be aware of the incident until communications, via the handset, was established by the cabin attendants (757 procedures require both pilots remain in the flight deck during an emergency). The flight deck would then initiate emergency procedures and begin diversion to the nearest airport. Air Traffic Control would be informed and a diversion started approximately eighteen to twenty minutes sooner than in the scenario. Upon landing, an emergency evacuation would be carried out. More efficient cabin floor proximity would facilitate evacuation in a smoke filled cabin. The potential for an increased number of survivors would be greatly enhanced.

7.1.2.2 Concept A

Concept A provides for a smoke detector in the lavatory amenities cabinet in addition to those already in the lavatory. The detectors provide warning to the flight deck and the three cabin attendant panels via the aircraft avionics bus.

The smoke detector in the amenities cabinet would alarm first, initiating a warning that is displayed at the cabin attendant panels and on the flight deck. The warning would occur sooner as the cabinet detector is located closer to the fire source. The cabin crew would respond to the alert by pushing the alert button on the cabin attendants panel and assessing the alert. The alert button informs the flight deck, non-verbally, that the incident is being investigated. The cabin attendants would inform the flight deck, via the handset, on the conditions and the procedures being deployed to manage the situation.

The cockpit would be immediately aware of the incident as the lavatory detectors are linked to the flight deck. The electronic checklist would be displayed, automatically with the triggering of the alarm, providing the flight crew with the procedures for the incident. This list would include the removal of electrical power to the effective lavatory, divert to nearest airport, and the smoke evacuation procedures to be undertaken if conditions warrant. Communicated with the cabin attendants would first be non-verbally and then by the hand-set. Once on the ground, an emergency evacuation would be initiated with the aid of the proximity floor lighting.

Time saved in landing the aircraft safely results from:

- a) The additional lavatory smoke detector located under the amenities counter;
- b) Flight deck alert displays linked to the lavatory smoke detectors;

- c) Reliable non-verbal communications between flight deck and cabin attendants;
- d) Automatic display of the emergency procedures.

7.1.2.3 Concept B

The Concept B airplane incorporates all the capabilities of Concept A with the addition of thermal detection in the cabin ceiling and an inflight diversion planner on the flight deck.

The scenario would progress as it did for the Concept A system. The thermal detection feature of Concept B would, most likely, not contribute to the initial detection. The inflight diversion planner would enable a faster decision in selecting a suitable airport with a reduction in crew workload. The planner provides information on landing field lengths, emergency services, and weather conditions. As conditions stabilized and the flight crew workload lessens the flight deck may choose to use the synoptic display to monitor the thermal conditions in the airplane, for information regarding any possible spreading of the fire. Upon landing, an emergency evacuation would be initiated. All passengers and crew members should survive.

Time saved in landing the aircraft safely results from:

- a) Additional lavatory smoke detector located under the amenities counter;
- b) Flight deck alerts linked to the lavatory smoke detectors;
- c) Improved non-verbal communications between flight deck and cabin attendants;
- d) Electronic checklist for automatic display of emergency procedures;
- e) Inflight diversion planner for alternative airport selection;
- f) Thermal monitoring capability using the synoptic display.

7.1.3 Scenario No. 3

This scenario involves a widebody four-engine jet with a two-person flight deck crew and ten member cabin crew. During the flight a fire warning in the aft cargo compartment sounded. Further investigation lead to the conclusion that the alarm was false. When the same alarm sounded a second time, emergency procedures were implemented. The fire extinguisher was discharged into the cargo compartment, the crew donned oxygen, and implemented smoke evacuation procedures (there was no smoke in the flight deck or cabin). Clearance for an emergency flight departure was requested and approval for diversion was received. Upon landing emergency evacuation procedures were conducted, resulting in minor injuries to some of the passengers. Investigation of the aircraft revealed that a smoke detector had malfunctioned because of a connector grounding.

7.1.3.1 Baseline 757 Airplane

The current 757 airplane has Class C cargo compartments, with dual smoke detectors and halon fire suppression capability similar in function to that of the scenario aircraft. The photoelectric smoke detectors are discrete in function but are "and" logic coupled to reduce the potential for false warnings.

Should a cargo fire warning be sounded, the crew response is to discharge the halon fire suppression agent and implement company emergency guidelines for diversion. The crew would not don oxygen or implement smoke evacuation procedures unless smoke was actually entering the flight deck and/or cabin. The diversion would be normal, that is choosing the closest airport available, weather conditions permitting. After landing the airplane would be evacuated utilizing standard procedures. There would be little or no change in procedures for the baseline aircraft from that of the scenario aircraft.

7.1.3.2 Concept A

The Concept A airplane incorporates photoelectric smoke detectors mounted in pairs that use consecutive pulse monitoring coupled with "and" logic to increase system reliability and to reduce false warnings. This would decrease the possibility of this scenario occurring. However, should this scenario occur, a fire warning would be displayed on the flight deck on the upper EICAS panel and the electronic checklist for this particular alert would be displayed on the lower EICAS panel. Immediate implementation of aft cargo compartment fire procedures would begin. These procedures entail discharging the No. 1 halon suppression bottle into the aft cargo compartment and begin diversion to the nearest airport. After eighty minutes or upon landing approach the second halon bottle is discharged. Emergency evacuation procedures would be initiated once the aircraft stops. There would be no changes from the basic scenario for either the baseline aircraft or Concept A aircraft.

7.1.3.3 Concept B

The Concept B airplane incorporates analog photoelectric smoke detectors mounted in pairs coupled with "and" logic to improve system reliability and to reduce false alarm warnings. The cargo compartment is also monitored for fire events by a digital output thermal detector. The ability to monitor two parameters of a fire event (smoke and heat) may provide a further reduction in false alarms, by requiring both parameters to "see" a fire. (Consideration should also be given to optical detectors as a second source due to their faster response time for "verifying" the primary detector).

Should a false alarm occur, the flight deck would be alerted by the cargo compartment fire warning system. The emergency procedure for an aft cargo fire would be displayed on the EICAS electronic checklist. Following the implementation of the emergency procedures, additional information on the nearest suitable airport would be available for selection by the flight crew on the inflight diversion planner, also displayed on the lower EICAS display. The use of the planner will reduce the time required for the flight crew to select and divert to an alternative airport. After completing the emergency checklist and selection of a secondary airport, the time history of the thermal and smoke profile could be monitored for changes in conditions within the cargo bay. Upon entering the landing approach the thermal profile could be briefly reviewed to determine if a full emergency evacuation procedure should be implemented. If the thermal monitor displayed no indication of heat buildup the emergency evacuation procedures may not be initiated and a more orderly deplaning could be conducted, thereby reducing the potential for passenger injury.

7.1.4 Scenario No. 4

This scenario involves a narrow-body three-engine jet with a two-person flight deck crew. A fire warning was sounded in the aft lavatory (later determined to be false). The lavatory was inspected by the First Officer and Flight Attendant, neither finding any sign of smoke, flame, or heat. The lavatory was placarded "OUT OF SERVICE" for the balance of the flight and the airplane continued to its destination. Subsequent inspection found a faulty detector.

7.1.4.1 757 Baseline Airplane

The baseline airplane is equipped with binary smoke detectors that sound an aural alarm from within the lavatory. A customer option is available that would display lavatory smoke and fire events on the Upper EICAS display.

When an alarm is sounded, the occurrence is investigated by the cabin crew and immediately reported to the flight deck. If there are no indications of smoke or fire, the detector would be reset, providing for continued monitoring. The lavatory may or may not be placarded as a matter of company policy and crew discretion. The captain may decide on a further action such as diverting. With the absence of any evidence to support the likelihood of a smoke or fire event, in all probability the flight would continue on to its scheduled destination.

7.1.4.2 Concept A

Concept A provides for additional detection capability in the lavatories by the addition of a smoke detector in the amenities cabinet. All lavatory fire warnings are displayed on the flight deck as well as on the three cabin attendant panels.

The cabin crew would respond to the alert, first by pushing the flashing button on the cabin attendants panel. This action provides for non-verbal communication with the flight deck for when the attendant pushes the button the light changes from blinking to steady state, thus alerting the flight deck that the cabin crew is investigating the alert. Following inspection of the alert the cabin attendant could then establish verbal communication with the flight deck over the aircraft intercom handset located on the attendants panel. The attendant would reset the alarm(s) and the lavatory would continue to be monitored. The lavatory may be placarded for the duration of the flight. The flight deck would be made aware of the initial incident upon the detector alerting. The alert would cause the electronic checklist to display the correct lavatory emergency procedures on the lower EICAS screen. The flight deck would know that the cabin attendants were responding to the emergency due to the capability of the cabin attendant panel. Once handset communications were established, the captain would decide what, if any, action should be taken. With the lack of collaborative data to indicate a problem, the flight would probably continue to it's scheduled destination.

7.1.4.3 Concept B

The response with the Concept B system would be the same as with Concept A. The detector alerts and crew procedures implemented are the same for both concepts. Should the flight deck crew decide to divert to an alternate airport then the inflight diversion planner would be available to provide alternate route and airport information.

7.1.5 Scenario No. 5

This scenario involves a widebody three-engine jet with a two-person flight deck crew and cabin crew of twelve. A smoky odor was detected in the aft cabin area by the flight attendant. Further investigation revealed a fire had started in the amenities counter from a discarded cigarette. The fire did not develop to the flame stage due to rapid detection and immediate extinguishing by the cabin crew. The fire was confirmed extinguished approximately seventeen minutes after detection but a decision was made to divert as a precaution. Emergency evacuation procedures were not implemented when the aircraft stopped. All passengers exited safely.

7.1.5.1 757 Baseline Airplane

The 757 baseline airplane is equipped with a photoelectric smoke detector in the lavatory ceiling and a thermal fused halon potty bottle above the waste paper container which discharges when the thermal fuse reaches its melting temperature. The ceiling smoke detector will provide an audible alert to the cabin crew and the procedures followed will be the same as in the above scenario.

7.1.5.2 Concept A

The lavatory smoke/fire detection for Concept A adds a smoke detector under the amenities cabinet in each of the lavatories. Each of the detectors is integrated into the avionics bus with the alerts displayed on the flight deck as well as at the three cabin attendant panels. An electronic checklist will display the proper emergency procedure the alerts. Events would be the same as in the base scenario.

7.1.5.3 Concept B

Concept B does not provide any additional smoke/fire detection systems that would enhance the performance of the aircraft or crew in this scenario. The chain events would probably unfold the same as they did in Concept A. However, Concept B is equipped with an inflight diversion planner capability that

provides information about the nearest airport, estimated time of arrival to the airport, runway length, and emergency services. The decision to divert and land is at the discretion of the flight deck crew.

7.1.6 Scenario No. 6

This scenario involves a widebody four-engine jet with a three-person flight deck crew and an unknown number of cabin crew. A passenger reports the smell of overheating electrical equipment. Upon investigation, the cabin attendant turned off the overhead lights and reported to the captain who directed the circuit breakers also be pulled. Subsequent investigation by the maintenance crew revealed a faulty light ballast unit in the ceiling area which overheated causing an odor in the cabin. Rapid detection and removal of electrical power prevented any smoke or fire. The flight continued to its destination.

7.1.6.1 757 Baseline Airplane

An overheated light ballast is assumed to have been detected and dealt within the same manner as the above scenario.

7.1.6.2 Concept A

The scenario for Concept A would be the same as the base scenario. However, earlier detection of the overheat and possible smoke might be detected by the overhead (ceiling) detectors. Air movement in the ballast area would certainly influence if smoke was to reach the ceiling detectors and alarm.

7.1.6.3 Concept B

The scenario for Concept B would be the same as the base scenario. With the apparent small amount of heat produced by the ballast unit, a ceiling mounted thermal detector would probably not detect the overheat conditions.

7.1.7 Scenario No. 7

This scenario involves a narrow-body two-engine jet with a two-person flight deck crew. Smoke began entering the flight deck from just below the flooring. A visual check of the instruments panels did not reveal any abnormalities. Smoke could not be detected in the cabin area. The crew donned masks and began implementing the emergency checklist for electrical fire and smoke shutdown procedures for the non-essential electrical equipment. An emergency was declared four minutes after detection. The source of the fire never progressed beyond the smoldering stage, but the smoke remained throughout the flight, both in the passenger cabin and on the flight deck. Fourteen minutes after detection the airplane landed at a diversion airport and was evacuated via the emergency slides. Subsequent inspection revealed a wire had overheated in one of the navigation computers producing the source of smoke.

7.1.7.1 757 Baseline Airplane

The 757 baseline airplane has photoelectric smoke detectors located in the E/E bay that would detect burning/smoking wiring. The detectors are linked to the avionics data bus and alerts are displayed on the EICAS display panels. All of the electrical equipment is protected from overheat by circuit breakers.

A wire overheat, as in the scenario, should be detected by the E/E bay detector triggering an alert on the flight deck. The recirculation fans would be shut off, thus venting the E/E bay cooling air and smoke overboard. The air packs would be commanded to high flow configuration. Diversion to an alternate airport is assumed to occur as in the base scenario.

7.1.7.2 Concept A

Concept A incorporates the same smoke detection sensors in the electronics equipment bays that is currently installed on the 757-200 baseline aircraft. These sensors are linked to the avionics data bus and alerts are displayed on the EICAS panels. In a smoke/fire alert in the lower electronics equipment bay the elec-

tronic checklist for this event will be displayed on the EICAS panel. The procedures are then manually implemented by the flight deck crew.

Time saved in landing the aircraft safely results from:

- a) Rapid detection of the smoke/fire event;
- b) Automatic display of emergency procedures to insure faster and correct implementation.

7.1.7.3 Concept B

The Concept B system incorporates the same smoke/fire detection equipment in the E/E bay that is utilized in both Concept A and the baseline 757. The emergency procedures for this type of event are the same as in the Concept A system and are displayed on the flight deck and implemented manually. If a decision to divert to an alternate airport is made, the inflight diversion planner provides data on alternate airports, field conditions, weather information, and flying time. The planner reduces crew work load in locating and setting course to a diversion airport.

Time saved in landing the aircraft safely results from:

- a) Rapid detection of the smoke/fire event;
- b) Automatic display of the correct emergency procedures;
- c) Inflight diversion planner for locating an alternate airport.

7.1.8 Scenario No. 8

This scenario involves a widebody two-engine jet with a two-person flight deck crew. Combustion started in a coat closet and smoke was detected in the cabin within a few minutes. Extinguishing started two minutes after detection and an emergency was declared five minutes after detection. A diversion was initiated seven minutes after detection and the fire was completely extinguished ten minutes after initial detection. The airplane landed and an emergency evacuation occurred twenty-two minutes after detection. Due to the rapid detection and extinguishing, the fire did not grow beyond the smoldering stage. Smoke in the cabin caused some passenger panic and several people were treated for smoke inhalation.

7.1.8.1 757 Baseline Airplane

The baseline airplane is not equipped with smoke/fire detectors in the closet or cabin area of the airplane. Detection would depend on the presence of the cabin occupants (passengers and crew) and be addressed in the same manner as the base scenario.

7.1.8.2 Concept A

Concept A provides for installation of smoke detectors to the cabin attic, spaced along the length of the ceiling and an electronic emergency checklist that provides guidance to the crew for addressing cabin smoke/fire emergencies.

A smoldering fire in a coat closet would be sensed by the smoke detectors located in the attic. Selective location of these detectors will provide better protection to the passenger cabin area and reduce the time required for detection at the onset of the emergency. The detector will provide an alert to both the flight deck and at the cabin attendant panels. The cabin crew would respond, pressing the correct alert light and begin an immediate investigation. Simultaneously, the fire warning will be displayed on the flight deck along with the electronic checklist. Once the cabin attendants assess the nature and severity of the alert, voice communication is established with the flight deck. The crew would initiate diversion procedures as a precautionary measure.

Time saved in landing the aircraft safely results from:

- a) Early detection by the smoke detector located in the attic area of the passenger cabin;
- b) Automatic display of the correct emergency procedures;
- c) Improvement in flight deck/cabin attendant communications.

7.1.8.3 Concept B

Concept B incorporates the same smoke detection capabilities of Concept A but has, in addition, a thermal detection system that monitors temperatures in the attic and the inflight diversion planner on the flight deck.

The outcome of the scenario for Concept B will be the same as for Concept A. Smoke will be detected by the attic detectors, with the similar responses by the cabin attendants and flight deck. The Concept B system is enhanced by the addition of the inflight diversion planner that provides information on the nearest suitable airports. The in-flight capability will assist in speeding the decision, at reduced workload, to land the aircraft at an alternate airport.

Time saved in landing the aircraft safely results from:

- a) Early detection by the smoke detector located in the attic area;
- b) Automatic display of the correct emergency procedures;
- c) Improvement in flight deck/cabin attendant communications;
- d) Inflight diversion planner identifies nearest suitable airports for possible diversion.

7.1.9 Scenario No. 9

This scenario involves a narrow-body two-engine jet with a two-person flight deck crew. The passenger cabin filled with smoke, that was initially thought to originate from an electrical failure. Subsequent trial and error analysis determined that the source of smoke was the left air-conditioning pack. The shut down for the left pack was followed by an engine fire warning that required engine shutdown and diversion to the nearest airport.

7.1.9.1 757 Baseline Airplane

In the baseline 757 airplane, the initial procedures for determining the source of cabin smoke is similar to that given above. Once it is determined that the smoke is not the result of an electrical problem, additional action to determine the smoke source would be initiated. The pack isolation procedures have been deleted from the 757 manual as changes in pack design has greatly reduced smoke being generated as a result of pack failure. To isolate a faulty pack the flight deck would need to employ a trial and error method, first shutting down one pack for 5 minutes and observing if the smoke decreases. If the smoke does not decrease, then the pack is brought back online and the second pack is shut down.

For engine fire warnings, the procedures require the immediate shutdown of the engine and diversion of the aircraft to the nearest suitable airport.

7.1.9.2 Concept A

Concept A incorporates a pair of smoke detectors coupled with "and" logic in each of the air conditioning pack outlets. The smoke detectors in the pack outlet will trigger an upper EICAS panel display "pack smoke alert," and the lower EICAS will display the pack isolation procedure. This procedure will hasten the shutdown of the pack before a significant amount of smoke could enter the cabin. Significant time in isolating a faulty air pack can be achieved with the implementation of the smoke detectors in the pack outlets by eliminating the trial and error procedures. Early detection and identification of the smoke source will result in a significant reduction in the amount of smoke that enters the passenger cabin.

The procedures for engine fire warning, emergency shutdown, and diversion are the same for both Concept A and the baseline. However, should the engine fire detection occur during the pack smoke alert, the electronic checklist has a priority override that establishes the higher priority of the two checklists, that is the engine fire. The electronic checklist will reduce the crew workload in identifying the source of the smoke, locating the correct procedures and establishing crew reaction priorities.

Time saved in landing the aircraft safely results from:

- a) Smoke detection capability in the two pack outlet ducts;
- b) Electronic checklist for automatic display and prioritization of emergency procedures.

7.1.9.3 Concept B

For a cabin smoke emergency scenario previously described, the Concept B system response would be identical to that performed in Concept A. Again, trial and error identification procedures are eliminated. Concept B will have the additional capability of the inflight diversion planner, that will facilitate landing the airplane at the nearest airport.

Earlier and precise detection of the smoke source and the electronic checklist capability would be the same as in Concept A. Concept B has the additional benefit of being able to identify the nearest diversion airport, at reduced crew workload, by the use of the inflight diversion planner.

Time saved in landing the aircraft safely results from:

- a) Early smoke detection - detectors located in the outlet duct of each pack;
- b) Electronic checklist for automatic display and prioritization of emergency procedures;
- c) Inflight diversion planner to identify nearest airport and reduce crew work load.

7.1.10 Scenario No. 10

This scenario involved a widebody tri-engine jet with a three-person flight deck crew and 11 member cabin crew. A lint and debris fire started in the sidewall area adjacent to the lower lobe galley from an arcing electrical power cable. The smoldering fire produced smoke that was distributed overhead, fore and aft within the cheek area. The small fire caused the failure of an aluminum hydraulic line that provided a source of additional smoke. The fire was detected, by the lower lobe galley smoke detector, nine minutes after ignition. After reviewing the proper procedures, the Flight Engineer was sent, with hand held fire fighting equipment, to investigate the fire. First attempts at extinguishing were not successful and were repeated in diminishing conditions. Air Traffic Control was informed of the smoke situation three minutes after detection but diversion was not started until forty minutes after detection. After reviewing several alternate airfields on the flight path, a military field was selected. Even though several airports were closer they were not selected due to runway length, weather or the availability of emergency equipment. The airplane was finally landed and evacuated seventy-seven minutes after detection. The fire had progressed and was in the flame stage just prior to landing. Ground firefighters finally extinguished the fire.

7.1.10.1 757 Baseline Airplane

The baseline airplane is a narrow-body and does not contain a lower lobe galley. Therefore, this scenario is not applicable to this aircraft.

7.1.10.2 Concept A

This scenario is not applicable to the 757-200 baseline aircraft due the absence of a lower lobe galley.

For a lower lobe galley equipped aircraft, an ionization smoke detector would be part of the ACES system, providing smoke/fire protection to this area, same as the base scenario aircraft. The detector would be linked to the cabin attendant panels and to the flight deck. The verbal and nonverbal communications feature that the ACES system provides between flight deck and cabin attendants would be beneficial to this type aircraft. For a two person crew aircraft, the responsibility for responding to a lower lobe smoke alert would be the duties of the flight attendants.

The electronic checklist would save considerable time in responding to lower lobe galley smoke/fire alerts. The correct procedures would be displayed on the lower EICAS screen upon the first indication of an alert to the flight deck. With the Concept A ACES system the cheek fire would be treated as a lower lobe galley fire, same as the base scenario. The low hydraulic system pressure alert would indicate that a higher priority problem was occurring and the procedure for such a event would be displayed on the electronic checklist. The information regarding a hydraulic system failure may alert the flight deck to the correct location of the fire.

Time saved in landing the aircraft safely results from:

- a) Automatic display of the proper emergency procedures which are prioritized to reflect the nature of the events;
- b) The cabin attendants panels and communication systems would provide for quicker exchange between the crew attending to the emergency and the flight deck.

7.1.10.3 Concept B

The Concept B aircraft has thermal monitoring capability installed in the lower lobe cheek and sidewall areas. A thermal or flame incident should be detected by the thermal detector in the cheek area when enough heat has been produced to increase the temperature around the sensing element. System resolution and the proximity of the heat source to the sensor are key elements in accomplishing early detection. The system would alert the flight deck as to the location of the overheat/fire thus avoiding the mistaken conclusion that it is a lower lobe galley incident. The emergency procedures for a cheek area incident would be to shed electrical load and possibly reconfigure the air distribution system to 100% fresh air. Identification and isolation of the smoke source quickly will provide time for other procedures such as smoke venting to be implemented before the conditions are noticed or intolerable in the cabin.

The inflight diversion planner will immediately provide the flight deck information on the nearest airports, weather conditions, and the availability of emergency equipment and services all of which contribute to the decision on where to land the aircraft. The synoptic display feature provides a time history of the incident that can be monitored on the flight deck. This capability would be of value if the intensity of the fire indicated a rapidly deteriorating situation, forcing the captain to choose a less than optimum airport for landing.

Time saved in landing the aircraft safely results from:

- a) Thermal monitoring, enabling correct diagnosis of incident location;
- b) Automatic display of the emergency procedures;
- c) Inflight diversion planner providing real time data on the location of the nearest suitable airport;
- d) Synoptic system display capability that provides a time history of the thermal detector output.

7.1.11 Scenario No. 11

This scenario involves a narrow-body two-engine jet with a two-person flight deck crew and five member cabin crew. Food trays left in a galley oven began smoldering and went unnoticed for a short period of time. The smoke was detected by a passenger twelve minutes after the smoke started. The cabin crew was

alerted and an initial attempt was made to extinguish the smoldering food. The smoking continued unabated. The First Officer was sent to investigate with an additional hand held extinguisher. A possible emergency was declared by the captain seven minutes after initial detection. Circuit breakers to the ovens were pulled, removing power from the galley four minutes after detection. The fire was confirmed extinguished twenty minutes after detection. A diversion was initiated twenty-seven minutes after detection due to problems of smoke in the cabin. The airplane landed without incident or the need for emergency evacuation. The doors were opened prior to taxiing to the gate.

7.1.11.1 757 Baseline Airplane

The baseline airplane does not incorporate smoke/fire detectors in the passenger cabin or galleys. Currently, the most reliable and sensitive detector is still the passenger when it comes to detecting smoke, odors, etc., in the open cabin area. The events would be the same as the above scenario.

7.1.11.2 Concept A

The Concept A aircraft will add additional detection capability to the passenger cabin: galley ceiling smoke detectors, attic ceiling smoke detectors, and the electronic emergency checklist to the baseline airplane.

The galley ceiling detectors would sense the smoke much sooner than given in the scenario. Ionization smoke detectors are extremely sensitive to very small aerosol/smoke particles. An alarm would be triggered at the cabin attendants panels and provide an advisory message on the flight deck. The cabin crew would respond to the cabin attendants panel chime and indicator lights that denotes the affected galley. The cabin attendants have the primary responsibility to first investigate and assess the source of the alert. Their initial cabin crew/flight deck communications would be nonverbal through the use of the cabin attendants panel. Verbal communication would then be established with the flight deck to apprise them of the on going nature of the situation.

The flight deck would become simultaneously aware of the incident via the Master Warning/ Caution alerting system. The electronic checklist would indicate the alarm originated in the aft galley and provide the procedures to be performed for an aft galley fire, including electrical power isolation and air distribution reconfiguration. The electronic checklist would save several minutes over the base scenario by removing the necessity to manually locate the procedures handbook. Smoke removal procedures would be available on the checklist if conditions should warrant their implementation.

Time saved in the aircraft safely results from:

- a) Quicker detection of smoke with galley smoke detectors;
- b) Automatic display of the emergency procedures;
- c) Faster communication between the flight deck crew and cabin crew by use of the cabin attendants panel.

7.1.11.3 Concept B

The Concept B aircraft has all the improvements of Concept A, plus the capability of both the inflight diversion planner and thermal monitoring.

The sequence of events would be similar to those described in Concept A above. After the flight deck completed steps given by the electronic checklist, the inflight diversion planner would be called up on the lower EICAS display to provide information on the nearest airport to be accessed. Data, such as time to the airport, weather conditions, runway lengths, and equipment available can be displayed.

Time saved in landing the aircraft safely results from:

- a) Faster detection as a result of smoke detectors installed in the galleys;
- b) Automatic display of the emergency procedures;
- c) Inflight diversion planner to provide information on available alternate airports.

7.1.12 Scenario No. 12

This scenario involves a narrow-body four-engine jet with a three-person crew. This was an all-cargo airplane on an overseas flight when a fire started in the main deck compartment from spilled corrosives. The fire was detected by the crew 34 minutes after ignition, when the smoke entered through the return air grilles that connected the cockpit to the avionics bay. The crew did not determine the location nor source of the fire. Two minutes after detection, a turn back was initiated, but there was no urgency to land at the nearest airport. En route, the conditions grew worse and the crew requested the closest airport. Control of the airplane was lost 36 minutes after detection and less than five minutes before landing due to the improper shedding of the electrical load. The yaw damper had been turned off.

Note: The baseline scenario does not define the fire detection system on the airplane, the air distribution system, nor the air path between the cockpit and main deck cargo compartment.

7.1.12.1 757 Baseline Airplane

The baseline airplane that most closely simulates the scenario aircraft is the 757 package freighter. This aircraft is configured with smoke detectors in the main deck cargo area. The cargo compartment is completely separated from the cockpit by a rigid barrier and the crew door does not penetrate the cargo compartment. The cockpit air supply is directly from the air pack and vents along the lower lobe cheek areas to the outflow valve.

In this scenario it is expected that the main deck smoke detectors would sense the smoke soon after the acid spill. This should remove the confusion which existed in the base scenario as to the location of the fire. The crew would initiate a diversion to the nearest airport. Early diversion (or turn back) would put the airplane back on the ground within 20 minutes (the same time it took the crew to detect the smoke in the baseline scenario), providing the crew time to evacuate the airplane.

7.1.12.2 Concept A

The Concept A aircraft would add dual, multi-pulsed, "and" linked smoke detectors to the main deck cargo compartment and an electronic emergency checklist on the flight deck.

The smoke generated from an acid spill, as described in the base scenario, is expected to be detected as described in the baseline 757 airplane. An alert of this type would cause the appropriate electronic emergency checklist to display the emergency procedures for controlling airflow in the fuselage and to divert to the nearest airport.

The ACES system, in conjunction with better flight deck awareness of smoke/fire incidents, should result in earlier detection of the event and diversion to an alternative airport, thus providing the crew additional time to evacuate the airplane.

Time saved in landing the aircraft safely results from:

- a) Detection of incident sooner;
- b) Automatic display of the emergency procedures;
- c) Heightened crew awareness of seriousness of a smoke/fire event

7.1.12.3 Concept B

The Concept B aircraft incorporates analog smoke detectors, a thermal monitoring system, the inflight diversion planner, and synoptic display to the Concept A system.

An acid spill, as described in the base scenario, would be detected at the same time as in Concept A (about 10 minutes after the spill). The electronic checklist would display the appropriate procedures and the inflight diversion planner would automatically display a selection of airports for possible diversion. The synoptic display system would be available to monitor both the level of smoke and temperature in the compartment while the aircraft is diverting to an alternate landing site.

Time saved in landing the aircraft safely results from:

- a) Detection of incident sooner;
- b) Automatic display of the emergency procedures;
- c) Inflight diversion planner for locating nearest airport;
- d) Synoptic display for monitoring event - thermal and smoke;
- e) Heightened crew awareness of seriousness of a smoke/fire event.

7.1.13 Scenario No. 13

This scenario involves a widebody two-engine jet with a two-person flight deck crew. A cabin fire started from a lighted match igniting papers and lighter fluid in a passenger's hand luggage. The fire quickly spread to adjacent seats and furnishings. The fire was detected in less than one minute and completely extinguished within four minutes. Five minutes after detection an emergency was declared by the Captain and a diversion initiated. During descent, after the aircraft had reached safe altitude and airspeed the doors were opened to improve smoke removal. The airplane landed and the evacuation was complete twenty-four minutes after the fire was detected. The fire did not develop beyond a short flame stage due to rapid detection and extinguishing.

7.1.13.1 757 Baseline Airplane

All newer airplanes use improved flame resistant materials for seats and interior furnishings. The incident would be instantly detected by the passenger responsible and responded to rapidly by the cabin crew.

The sequence of events would not differ from the base scenario.

7.1.13.2 Concept A

Concept A has smoke detectors in the attic area, electronic checklist, and expanded cabin attendant panel capability.

The sequence of events would be similar to the base scenario. Given the speed with which the incident was detected by the cabin attendants the attic smoke detectors would not be expected to respond until after the flight deck had been informed by a cabin attendant. The flight deck would access cabin smoke venting procedures by using the electronic emergency checklist. The flight deck crew would remain on the flight deck and rely on the cabin attendants to communicate using the handset. The scenario would progress in the same manner as described in the baseline 757 case.

7.1.13.3 Concept B

The application of the Concept B systems to this scenario would have similar results to those expected in Concept A. The addition of the inflight diversion planner to Concept A is the single feature that has an impact.

Events would be similar to Concept A, however, the inflight diversion planner would reduce the workload of identifying and navigating to a diversion airport. Due to the rapid extinguishing of the fire the attic detectors, smoke and heat, would probably not alarm.

7.1.14 Scenario No. 14

This scenario involves a narrowbody, Combi configured aircraft with the Class B main deck cargo compartment located in the forward half of the airplane. The aircraft carries a two person flight deck crew and a full complement cabin crew, one of whom is the on-board firefighter (F/F). The Class B cargo compartment is equipped with a smoke detection system but no extinguishing capability, other than hand held extinguishers deployed by the on board F/F. Two hours after take-off a smoke odor is noticed by a cabin attendant, who relays the information to the flight deck. The flight crew evaluates the aircraft systems and no abnormal conditions are found. The odor increases and the flight deck is again informed. The F/F enters the main deck cargo compartment to investigate. Upon entering the source of smoke becomes evident as a thin haze hangs in the air. Simultaneously the smoke alarm sounds on the flight deck. The flight deck crew initiates a diversion to an alternative airport following the first indication of alarm. The F/F then retrieves a fire extinguisher charged with halon. Upon returning to attack the fire he finds the smoke density has increased dramatically and alerts the flight deck. A cargo pallet is the source of the smoke, due to low visibility the best place to discharge the halon is difficult to determine. The F/F discharges the halon and goes to retrieve a second extinguisher. Following the discharge of the second extinguisher the situation appears to improve. The F/F leaves the compartment to escape the irritating smoke after having assessed the situation as stabilized. Smoke had entered the passenger compartment causing noticeable tension among the passengers. The F/F prepares to reenter the compartment to further assess the situation. Smoke continues to enter the passenger compartment whenever the F/F opens to door to enter the cargo compartment. The passenger compartment slowly clears of smoke, but passenger anxiety is high. The nearest airport remains 40 minutes away. The Class B cargo compartment remains full of smoke for the duration of the flight, but no additional smoke enters either the passenger compartment or the flight deck. The airplane lands and the emergency slides are deployed to evacuate the aircraft.

7.1.14.1 757 Baseline Airplane

The 757 Combi configured airplane employs "fire blankets" to cover all palletized cargo, a trained F/F, and a smoke detection system. The fire blankets cover the cargo to form a mini Class D cargo compartment. Any fire occurring inside the cover pallet will be suppressed as a result of oxygen starvation. If smoke should leak out from under the blanket the smoke alarm would sound and the F/F would don a fire protection suit and investigate/attack the fire using hand held fire extinguishers. The event should not progress to the extent it did in the base scenario, minimal smoke should enter the passenger compartment.

7.1.14.2 Concept A

Concept A has multi-pulsed "and" linked photoelectric smoke detectors in the Class B cargo compartment and an electronic checklist on the flight deck. Fire blankets are assumed to be used in future 757 Combi aircraft. The electronic checklist would insure that all flight deck procedures would be carried out in a timely and correct manner. This scenario would duplicate the 757 baseline situation; minimal smoke should enter the passenger compartment and the passengers may well never know of the incident until the emergency evacuation was made.

7.1.14.3 Concept B

The addition of a thermal monitoring system, the inflight diversion planner, and the synoptic display are the Concept B features that contribute to improvements in this scenario.

The smoke alarm would cause the electronic checklist for a main deck cargo fire to be displayed on the lower EICAS screen. The flight crew would implement the emergency checklist procedures, consult the inflight diversion planner for information on the availability of airports and make flight path changes as required. If time permits, or the situation demands, the synoptic display will be called up and the detector

output from both the smoke and thermal detectors could be monitored. The synoptic display will provide the flight deck with information regarding the ongoing conditions in the (Class B) cargo compartment. The information would be of great value should the smoke/fire event intensify requiring a more severe diversion action as a result of thermal conditions reaching catastrophic levels.

An interesting and alternative approach to fire blankets has been designed by Pellew Engineering and is discussed in Section 6.3.8.1. The Pellew system connects each container and/or pallet to a monitoring/suppression system on-board the aircraft. The smoke would be detected at a very early stage, by the miniaturized CO monitor, the flight deck would be alerted and initiate discharge of a fire suppression agent (halon) to the targeted container/pallet. The Pellew system, in effect, makes each container and covered pallet a mini Class C cargo compartment - smoke/fire detection and suppression. An emergency would be declared and the inflight diversion planner would be used to locate the nearest available airport.

8. CONCLUSIONS

Given the outstanding safety record and performance of the 757-200 baseline aircraft, improvements can be further realized with the implementation of new capability sensors now on the commercial market.

- 8.1 The reaction/response time to an inflight smoke/fire emergency can be significantly enhanced with the implementation of an electronic checklist of emergency procedures tailored for specific events.
- 8.2 Both verbal and nonverbal communications between the flight deck and cabin crews can be significantly improved with a new cabin attendants panel that interfaces with both the cabin sensors and aircraft data bus.
- 8.3 The potential for false alarms, the necessity to divert to an alternate airport, and subsequent passenger injuries sustained in emergency evacuations, can be significantly reduced with the implementation of new types of sensor systems, computer controls and displays.
- 8.4 Once an emergency situation has been declared, the inflight diversion planner can be utilized to facilitate a more expedient decision as to where to land by providing the flight deck crew with alternate airport information, including estimated time en route, runway suitability, weather, and rescue and fire fighting capability.
- 8.5 Thermal monitoring affords the flight deck crew the opportunity to establish and monitor various compartment temperatures before an alarm has sounded and a response has been initiated, and may provide indications to the flight crew that other procedures must be initiated earlier than normal.

References

- Reference 1 Blomberg R. D., et al. (Dunlap and Associates), "Technology Assessment for Aircraft Command in Emergency Situations," DOT/FAA/CT-87/20. October 1988.
- Reference 2 Maylor, E. L., "Airplane Tests of Enhanced Emergency Smoke Venting," DOT/FAA/CT-89/9, March 1989.
- Reference 3 "Aircraft Fire Detection System," Heath Tecna Aerospace Co., Kent, WA January 1987.
- Reference 4 Hughes Associates, "Integrated Fuselage Fire Detection and Monitoring System," DTRS 57-87-C-00093, September 3, 1988.
- Reference 5 Jamco, Japan Aircraft Maintenance (America) Inc., 1018 80th Street SW, Everett, WA 98203.
- Reference 6 Autronics Corporation, 314 East Liveoak Avenue, Arcadia, CA 91006.
- Reference 7 "757-200 and 757-200PF System Description and Failure Analysis - Lower Lobe Cargo Compartments Smoke Detection and Fire Extinguishing Systems," Boeing Document D210N405, January 1982.
- Reference 8 Berson, B. L., et al., "Aircraft Alerting Systems Standardization Study, Volume II: Aircraft Alerting System Design Guidelines," DOT/FAA/RD-81/38,II, January, 1981.
- Reference 9 American Society of Heating, Refrigerating and Air-Conditioning Engineers (ASHRAE).
- Reference 10 Bright, R. G., and Custer, R. L., "Fire Detection: State-of-the-Art," National Bureau of Standards, NSB Technical Note 839, June 1974.
- Reference 11 Research Equipment Corporation, 3125 Ashley Phosphate Road, Suite 110, North Charleston, SC 29418.
- Reference 12 Senturia, S. D., "Fabrication and Evaluation of Polymeric Early-Warning Fire Alarm Devices," NASA Contract No. NAS3-17534, 1975.
- Reference 13 Pfister, C., "Detection of Smoke Gases by Solid State Sensors - A Focus on Research Activities," Fire Safety Journal, 6 (1983) 165-174.
- Reference 14 Battelle, Columbus Division, ASRS Office, M. A. Wagner & E. S. Cheaney, researchers. Incidents Involving Checklist Problems, Requested ASRS search report, June 10, 1988.
- Reference 15 Gamewell, Ten Forge Park, Franklin, MA 02053.
- Reference 16 Geamatic Control System AB, Långebergsgatan 14, South 421 32 V, Frölunda, Sweden.

References (Continued)

- Reference 17 Fike Protection Systems, 704 South 10th Street, P.O. Box 610,
Blue Springs, MO 64013-0610.
- Reference 18 York V.S.O.P. York House, School Lane, Chandlers Ford, Hampshire,
SO5 3DG, UK.
- Reference 19 Schlumberger Industries, Transducer Division Enfield,
580 Great Cambridge Road, Enfield, Middlesex EN1 3RX, England.
- Reference 20 Pellew and Company (PTY) Ltd., Manufacturing and Consulting
Engineers, 29 Yaron Avenue, 430 Maralsburg 1710
Republic of South Africa.
- Reference 21 HTL/Kin Technology Division, Pacific Scientific, 1800 Highland Avenue,
Duarte, CA 91010.

Appendix A
Smoke and Fire Detector
Summary

Detector Performace Summary

<u>Detection Device</u>	<u>Advantages</u>	<u>Disadvantages</u>	<u>Comments</u>
Infrared Detectors	Rapid response time (10 ms) Moderate cost	Affected by ambient temperature changes	Indoor fires A, B class fires
Ultraviolet Detectors	Insensitive to sunlight Rapid response time Very sensitive to fires Automatic self test	Detects only flame Blinded by smoke Subject to false alarms Detects only flame	Outdoor/indoor applications A, B & D class fires
Photoelectric (several types - see below)	Can be faster than ion detectors Can be used with a fixed piping system Low unit cost Adjustable sensitivity		Indoor use where smoke is contained Generally less sensitive to black than paler smoke
Beam-Type Photoelectric	Capable of detecting incipient fires	Sensitive to voltage variations Sensitive to dirt on lamp or lens	Photoelectric detectors respond to 2nd stage (smoldering) fires
Reflected Beam Photoelectric (spot-type)	Capable of detecting incipient fires Sensitive to pale smoke Not sensitive to variations in temperature, humidity or air movement	Requires high battery standby capacity	
Gas (Fume) Detectors	Multi-point monitoring remote system Not affected by changing environment Rapid response Alarm points can be preset	Expensive	Generally used for industrial hazard monitoring
Ionization detector (several types - see below)	Low unit cost Incipient fire detection	Easily contaminated Excessive dust triggers false alarms	Indoor use class A, C & D fires Contains small amount of radioactive material
Single Chamber	Most economical of this class	Can be affected by changes in weather or altitude	Generally best in low air turbulence and no heavy accumulation of smoke
Dual Chamber	Accepts wide rage of atmospheric variations without false alarms		Low voltage units have low profile detector heads

Detector Performace Summary (Continued)

<u>Detection Device</u>	<u>Advantages</u>	<u>Disadvantages</u>	<u>Comments</u>
Low-voltage	Needs only 24 volts	Increased temperature can decrease sensitivity	Generally sensitivity decreases with humidity and increasing altitude
Combustion Resistance Bridge/Ion	Dual mode - less false alarms Less sensitive to dust, aerosol sprays and humidity		Both modes must detect fire by-products Resistance bridge detects water driven off by fire
Triple Chamber Ionization Detector	Third chamber improves sensitivity and stability Wide temperature range (-20° to 80°F)		Chambers are reference, detection, and balance screening In theory, improved electronics design and reliability will make multiple chambers unnecessary
Fixed Temperature	Simple Inexpensive Low power consumption	Heat activated	Used where no life hazard is present
Metallic Rate-of-Compensation Thermal Detectors	Detects preset temperature	Activated by rapid temperature increase	Not smoke sensitive
Rate-of-Rise Thermal Detectors	Simple Low cost	Heat must impinge Detects only rapid temperature increase	
Line-Type Thermal Detectors	Can take severe abuse Alarms at low ΔT s	Only detects ΔT s	
Line-Type Detectors Conveyor	None	Not applicable to Lavatory-galley fire detection based on available information	Used only on belt bearings
Bulb Detection System	Simple No electricity required Can activate mechanical extinguishing system	Detects hear rise and corresponding ΔP	
Condensation Nuclei Detector	Detects incipient fires	Requires plumbing	
Laser Beam Detector	Detects heat and smoke	Expensive Little information available	
Taguchi Gas Sensor	Low cost	Senses gases not combustion products	Not a smoke detector

Appendix B
757-200 General Description

757-200 General Arrangement

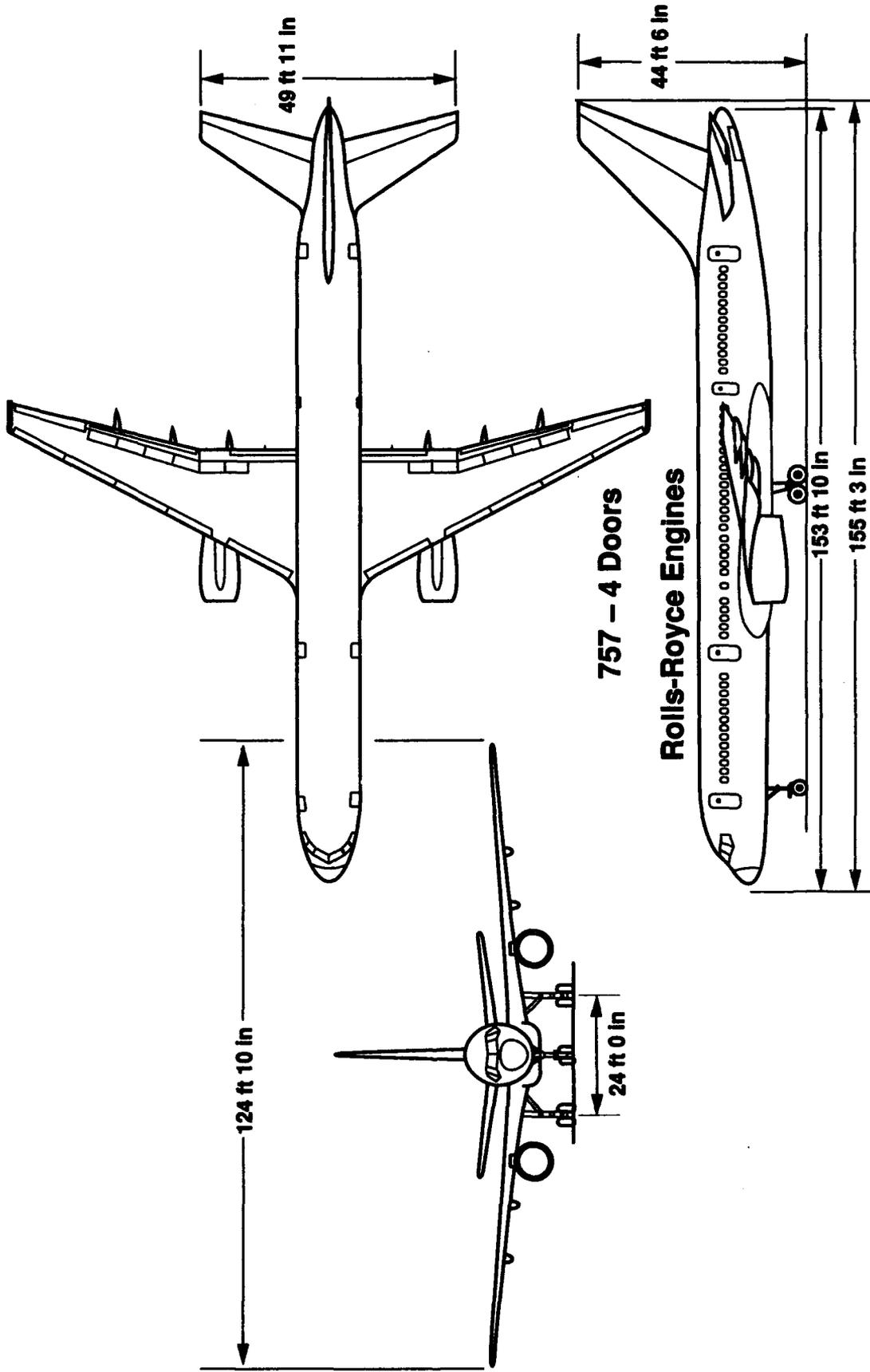

Appendix B

Principal Characteristics

757-200, Passenger

	English	Metric
Overall Dimensions		
Length	155 ft 3 in	47.3m
Height	44 ft 6 in	13.6m
Tread	24 ft 0 in	7.3m
Wheel base	60 ft 0 in	18.3m
Wing		
Span	124 ft 10 in	30.0m
Area	1951 ft ²	181.2m ²
Sweep	25 deg	25 deg
Engines, sea level static thrust		
Rolls-Royce		
RB211-535E4	40 100 lb	18 200 kg
RB211-535E4-B	43 100 lb	19 500 kg
Pratt & Whitney		
PW2037	38 200 lb	17 350 kg
PW2040	41 700 lb	18 900 kg
Fuel Capacity	11 276 USG	42 680L

	English	Metric
Design weights		
Maximum brake release	220 000 lb	99 700 kg
Basic	230 000 lb	104 300 kg
Option	240 000 lb	108 800 kg
Option	255 000 lb	115 600 kg
Maximum landing	210 000 lb	95 200 kg
Maximum zero fuel (P&W)	188 000 lb	85 300 kg
Maximum zero fuel (R-R)	184 000 lb	83 500 kg
Cabin length	118 5 in	36.1m
Bulk cargo volume	1790 ft ³	50.7m ³

Body Station Diagram

757-200, Overwing Exits, Four Door, Combi and PF

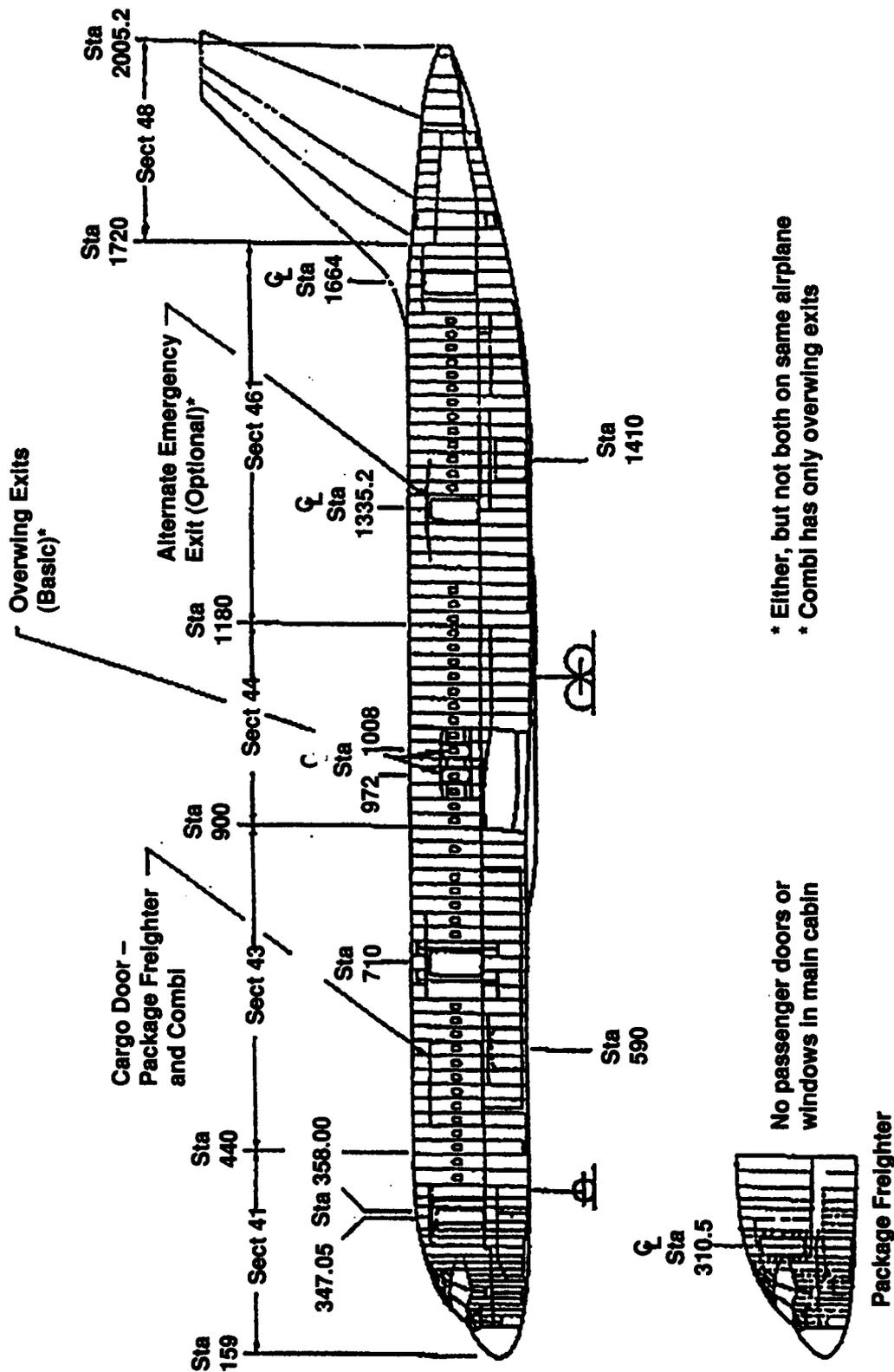

* Either, but not both on same airplane
 * Combi has only overwing exits

No passenger doors or windows in main cabin Package Freighter

Package Freighter

Appendix B

Body Cross Section

757-200, Basic Airplane

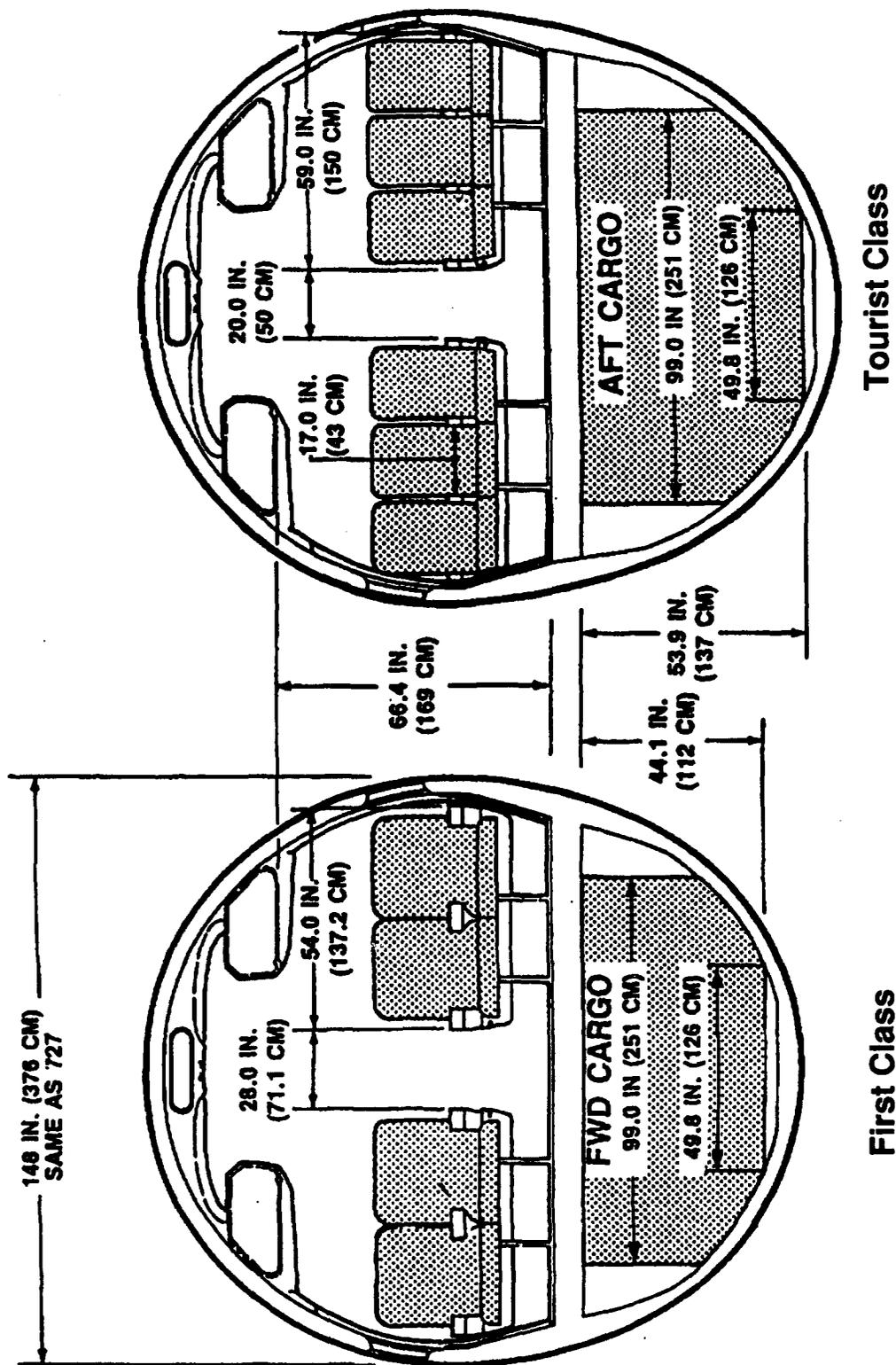

Appendix B

Appendix C
Software Design
Architecture

ACES

Level 0 DFD

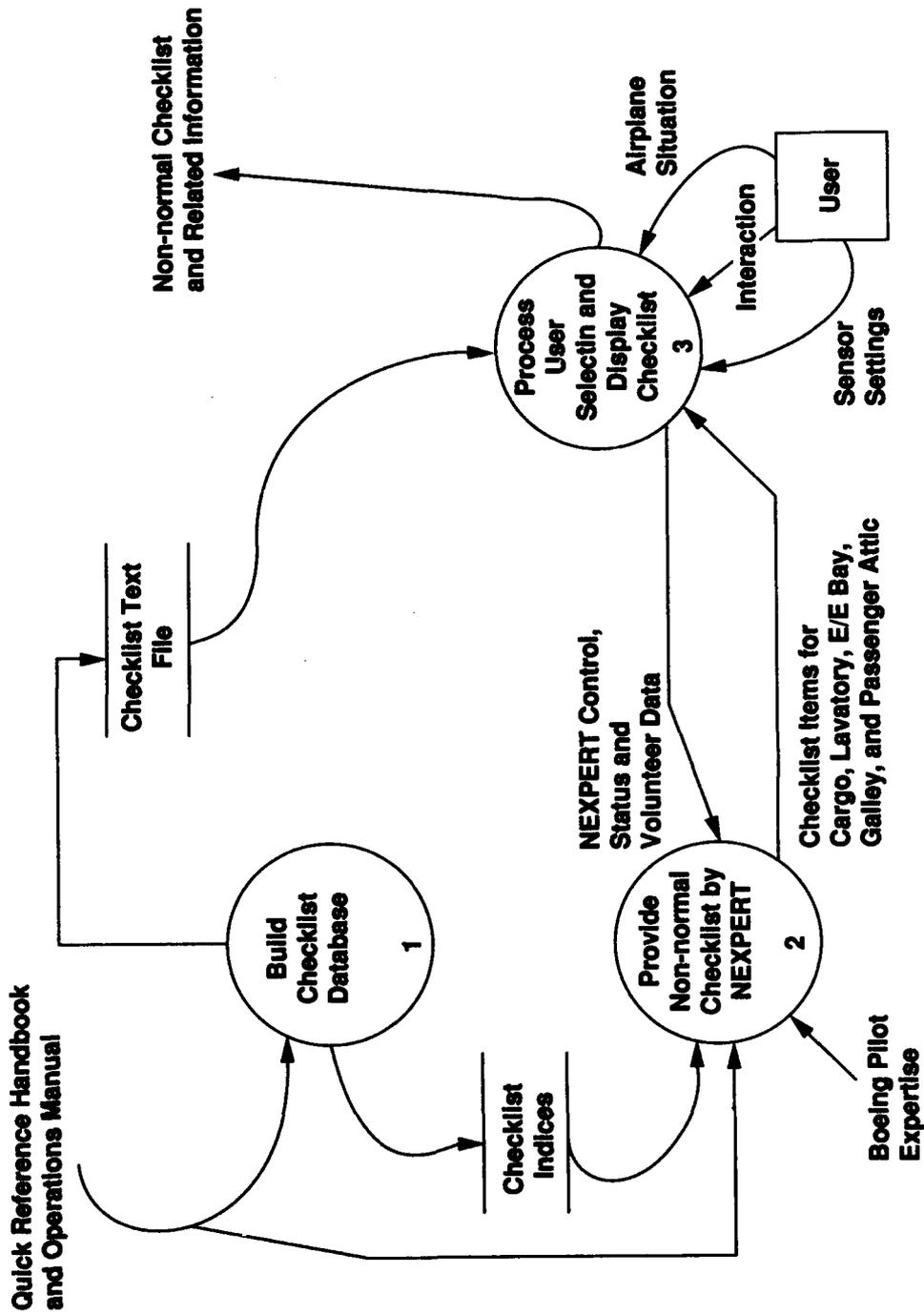

Appendix C

ACES

Level 1 DFD

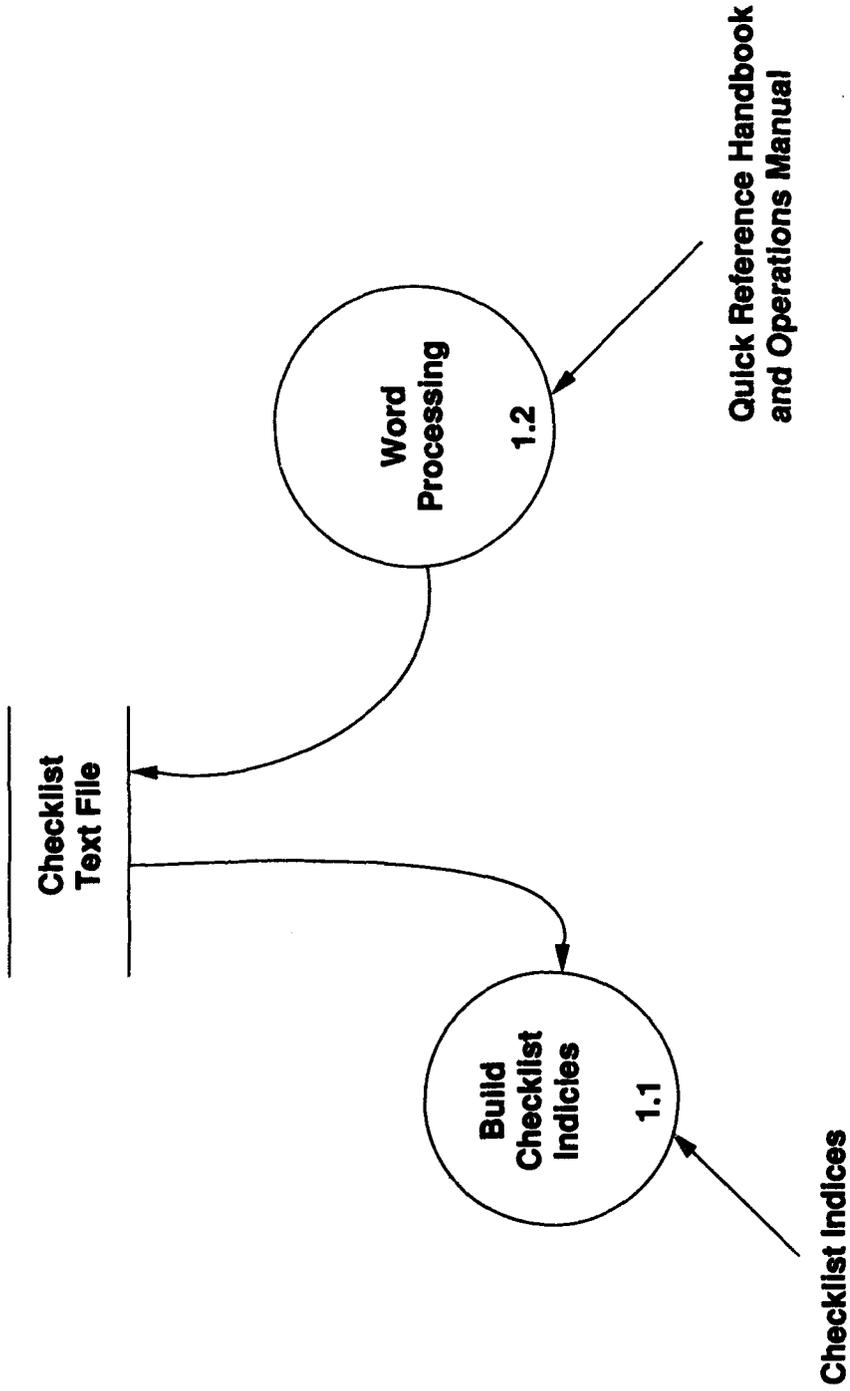

ACES

Level 2 DFD

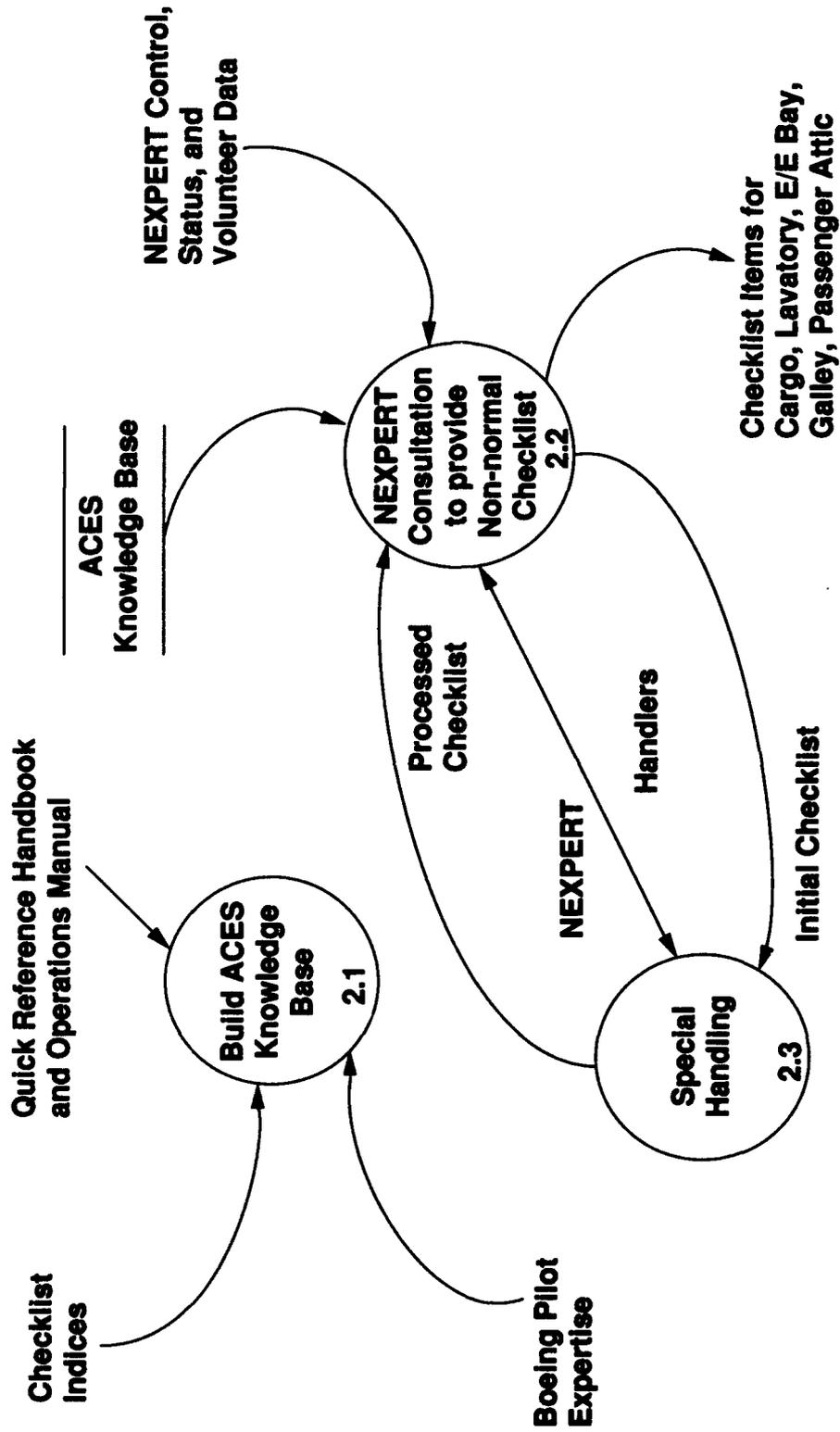

ACES

Level 3 DFD

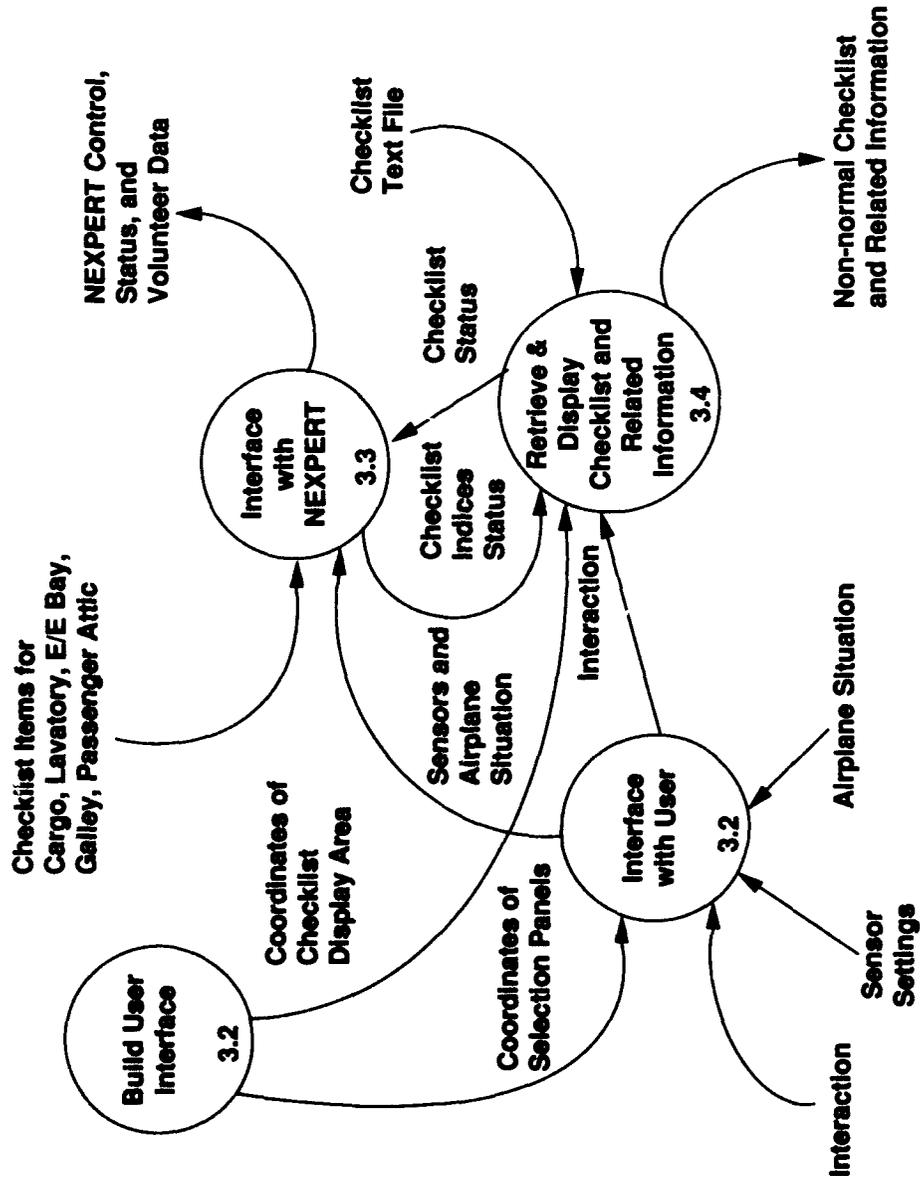

ACES

Level 3.4 DFD

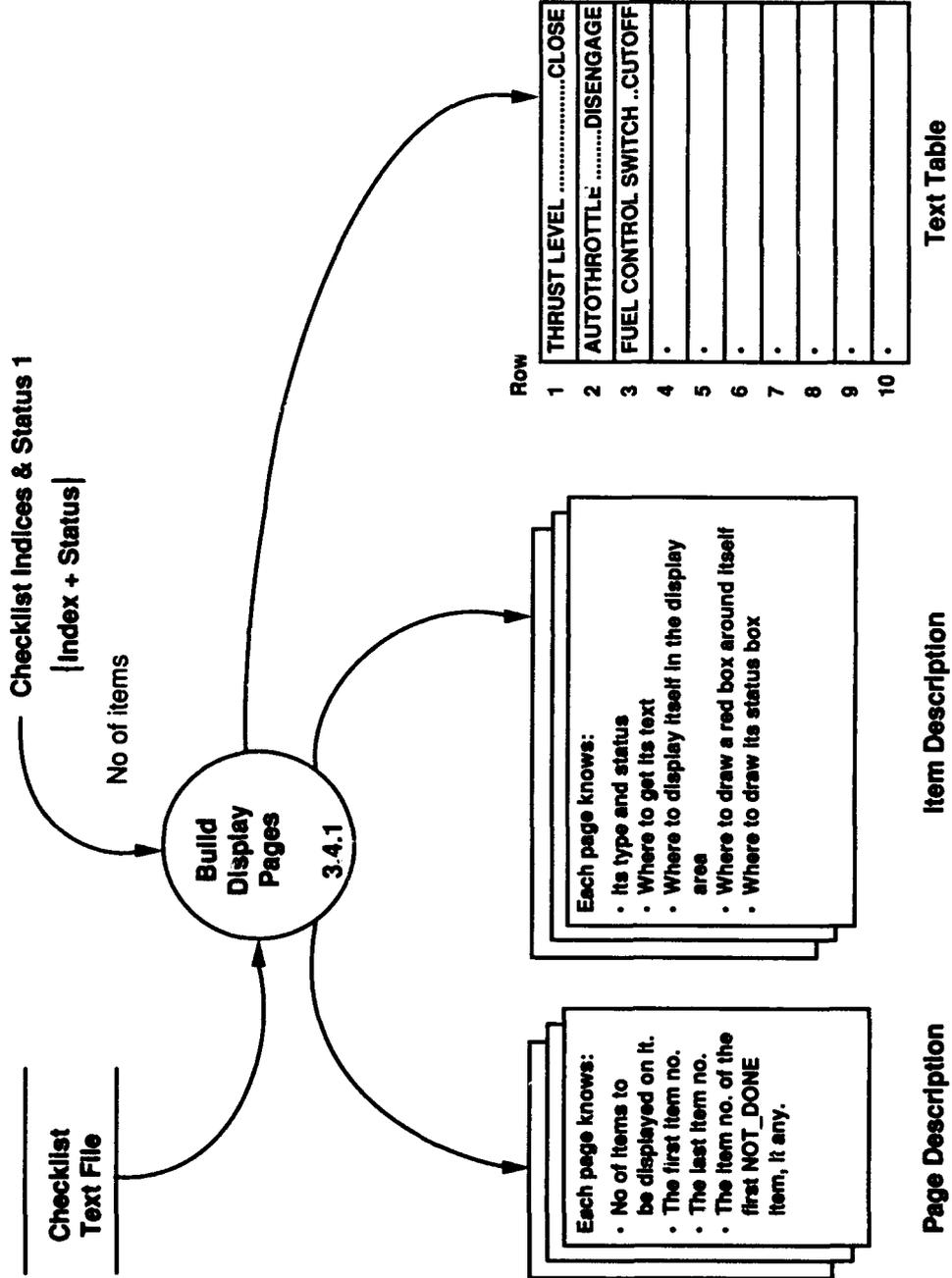

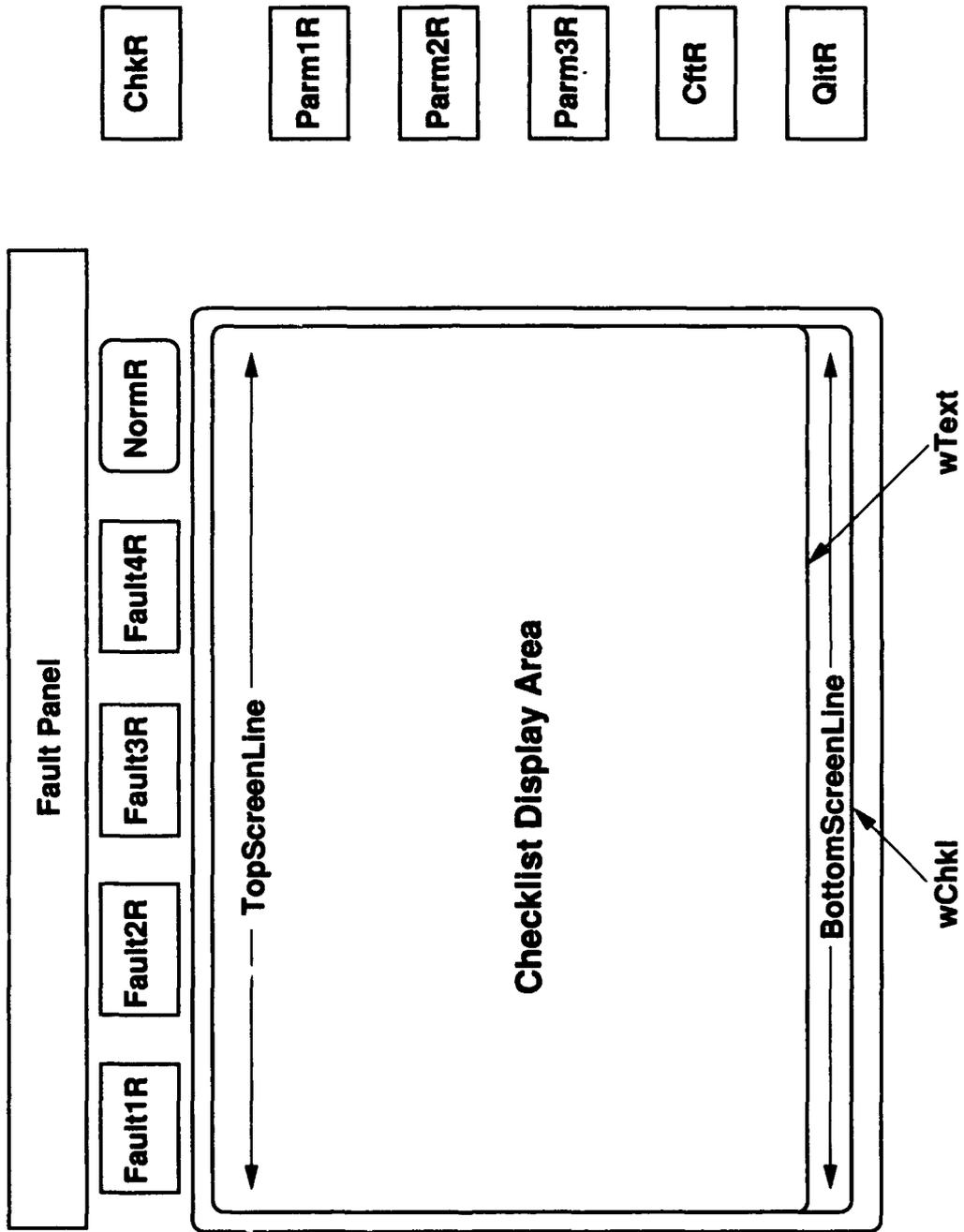

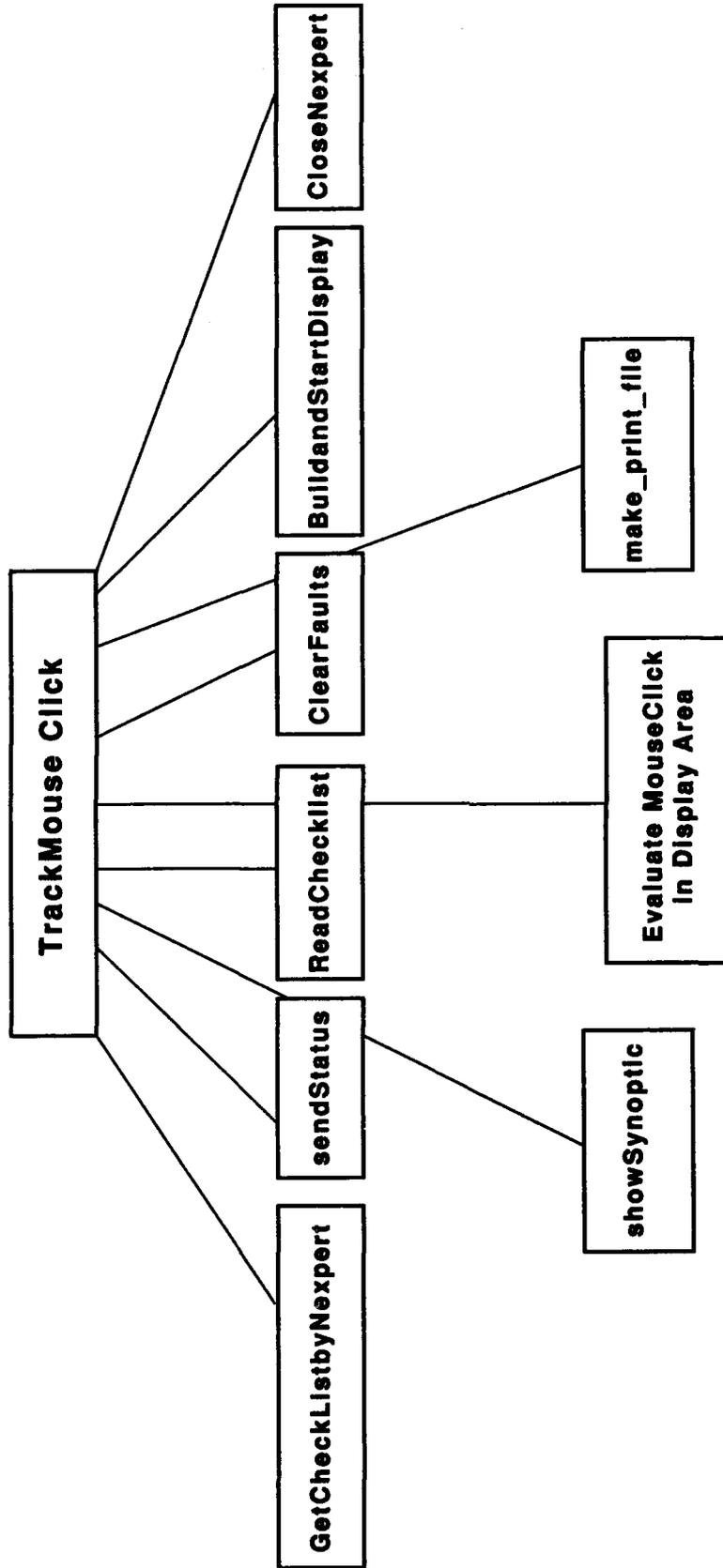

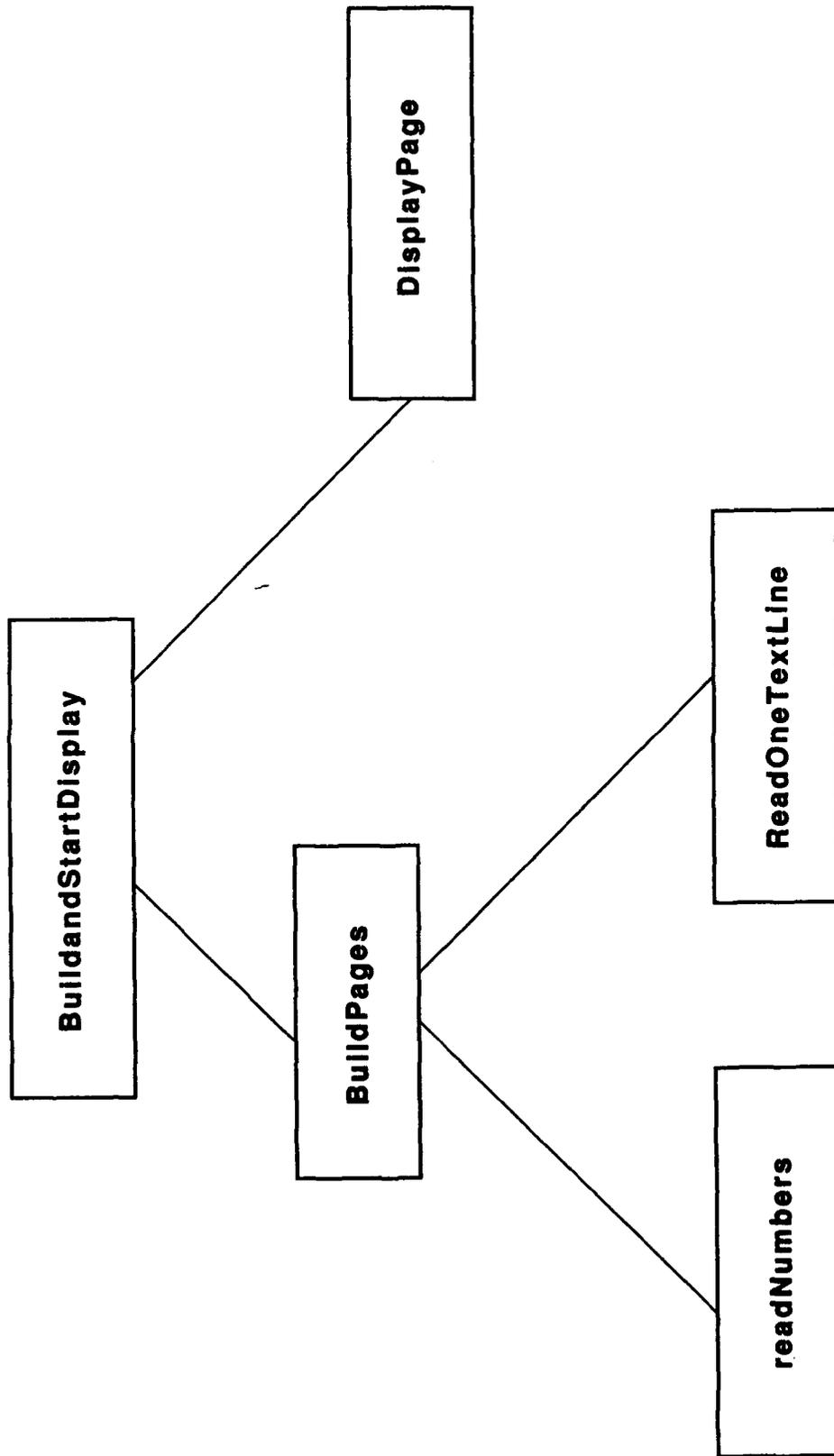

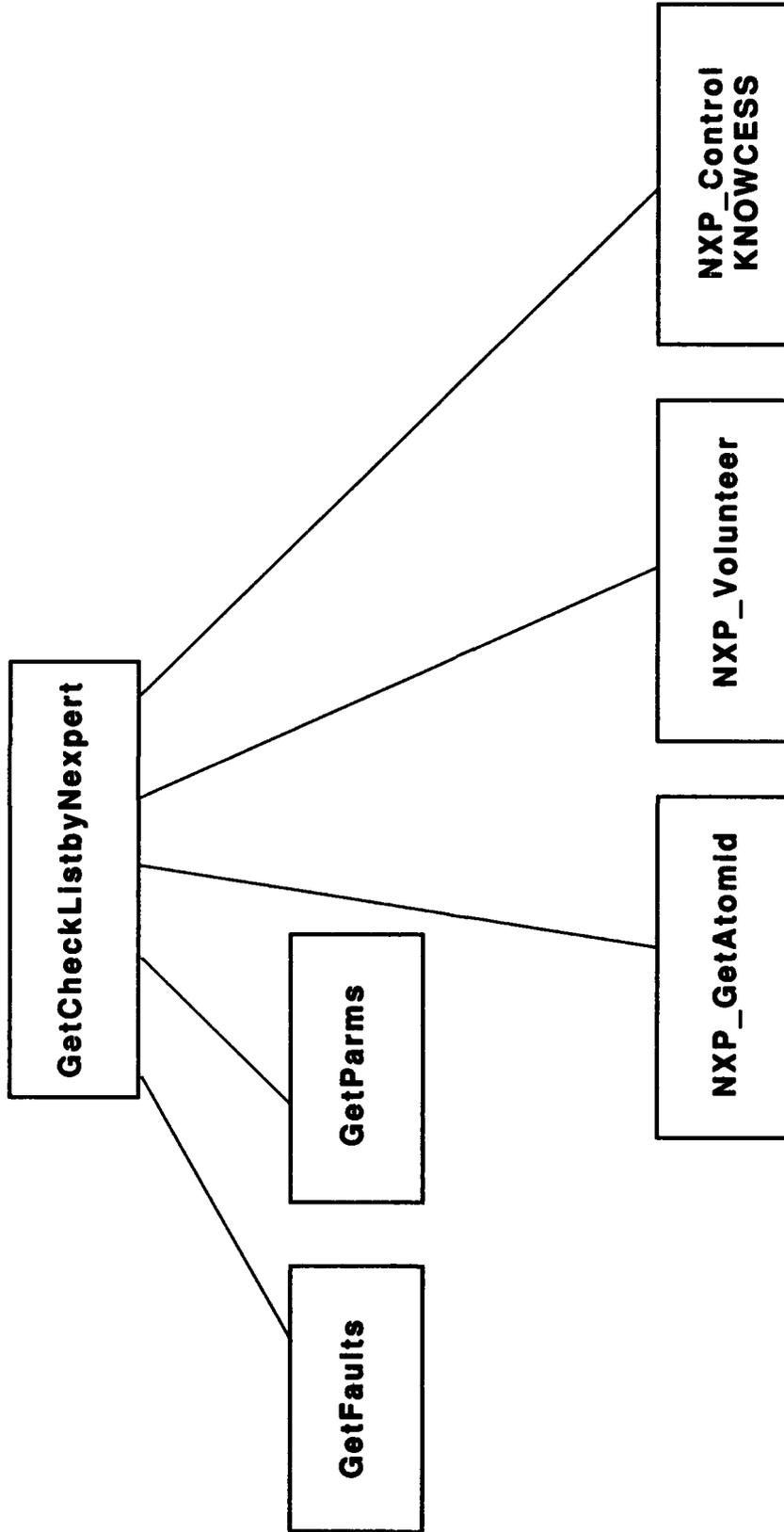

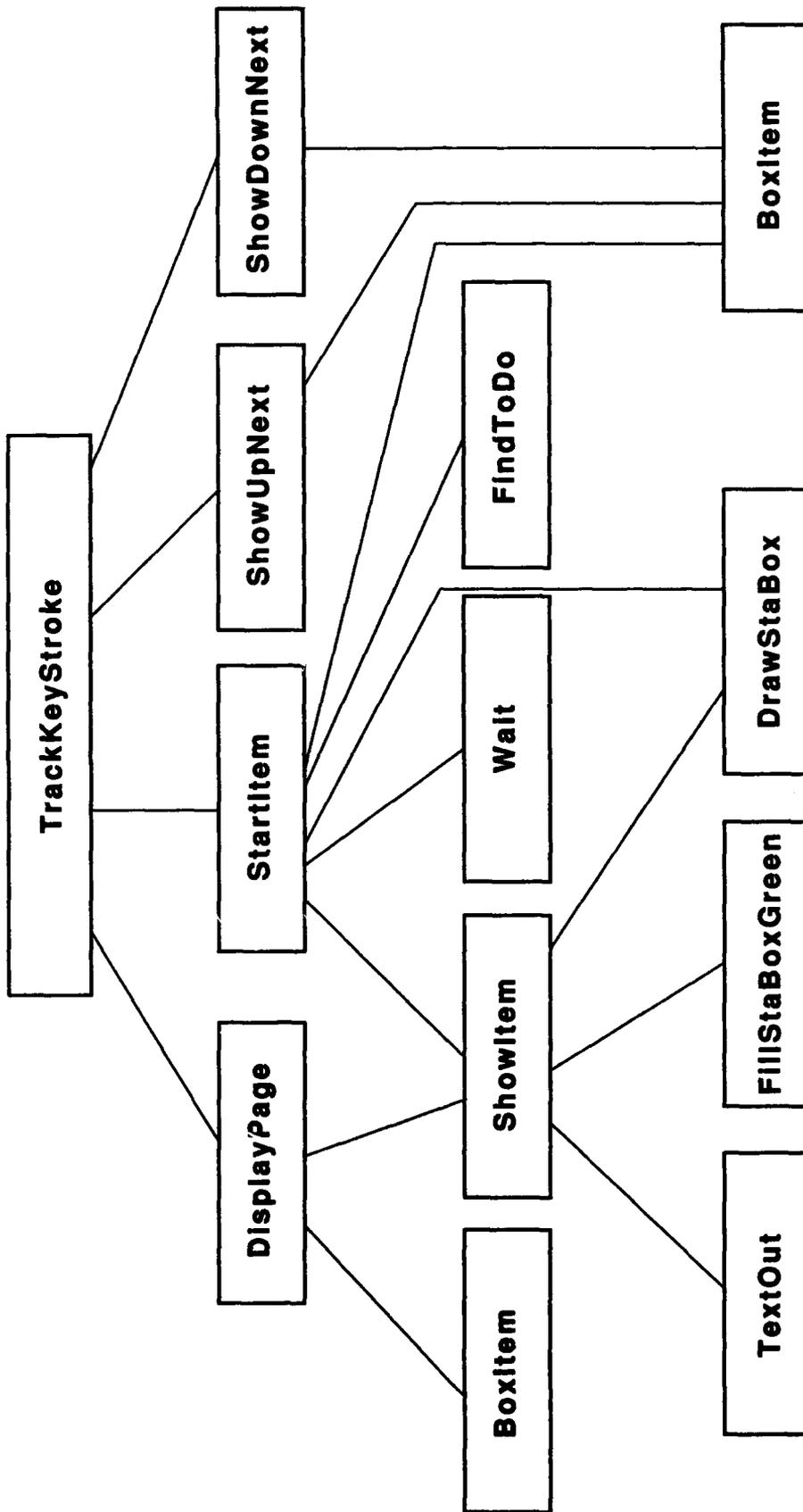

Structure Chart of Keystroke Tracking Program

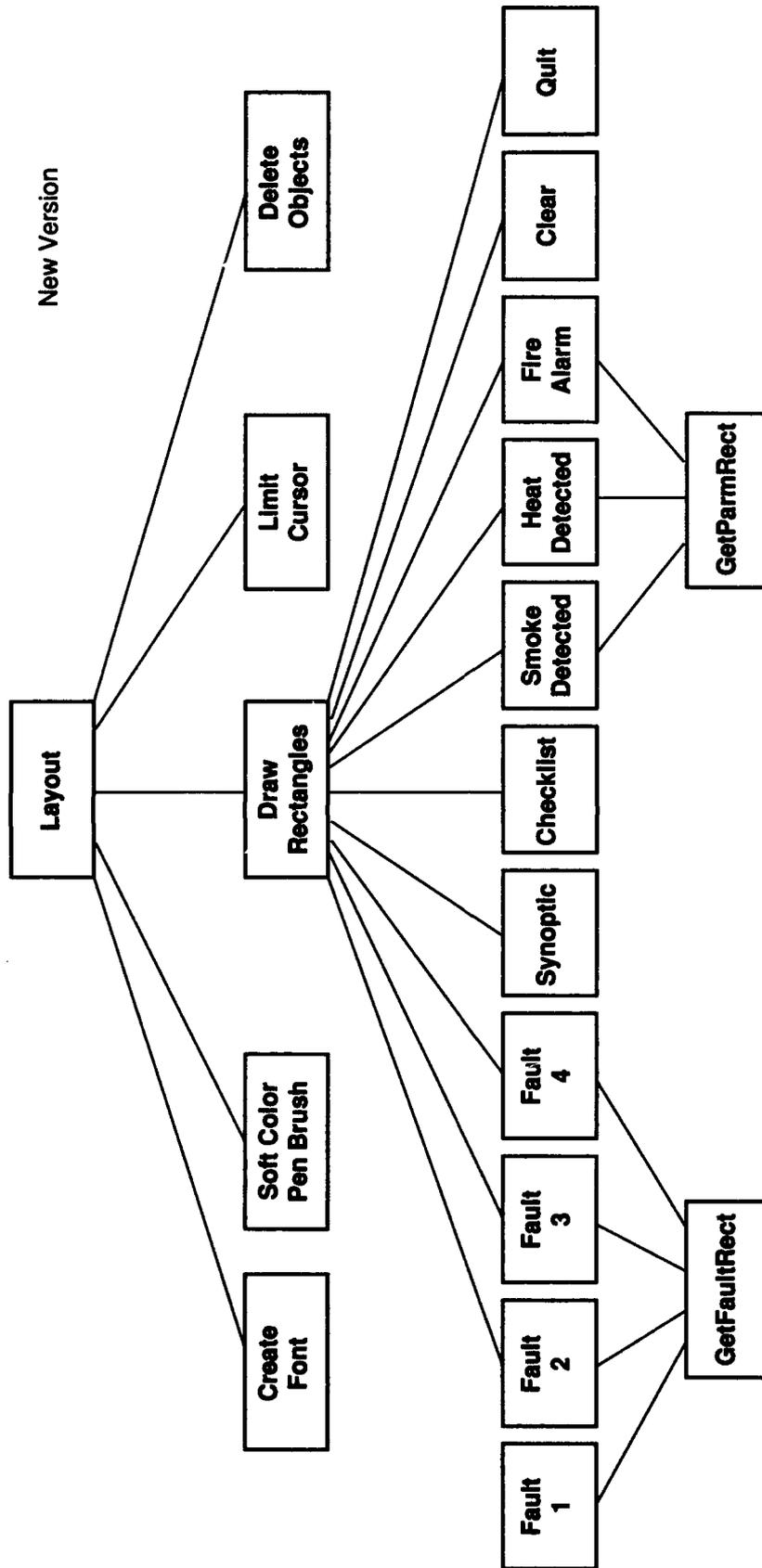

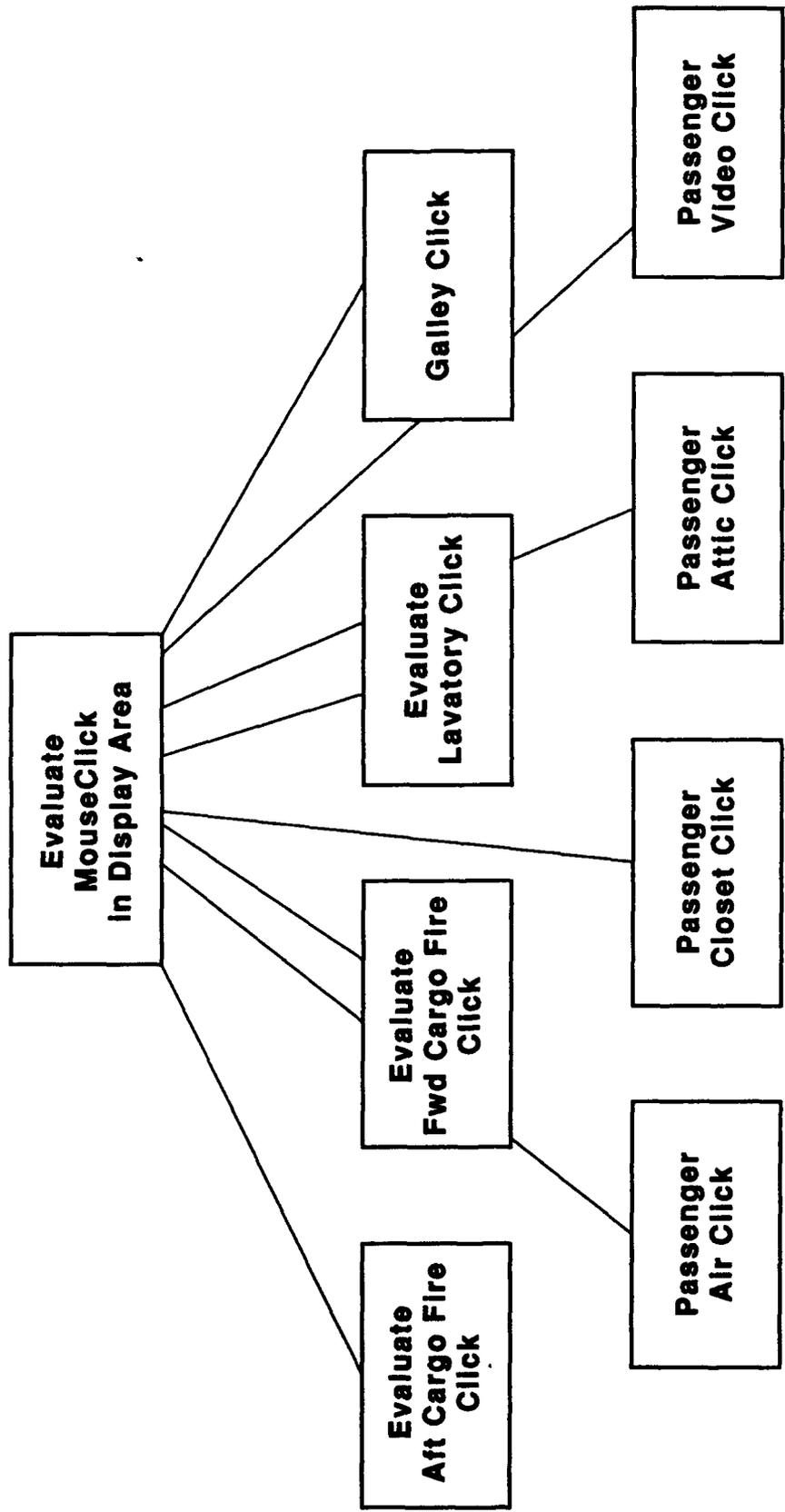

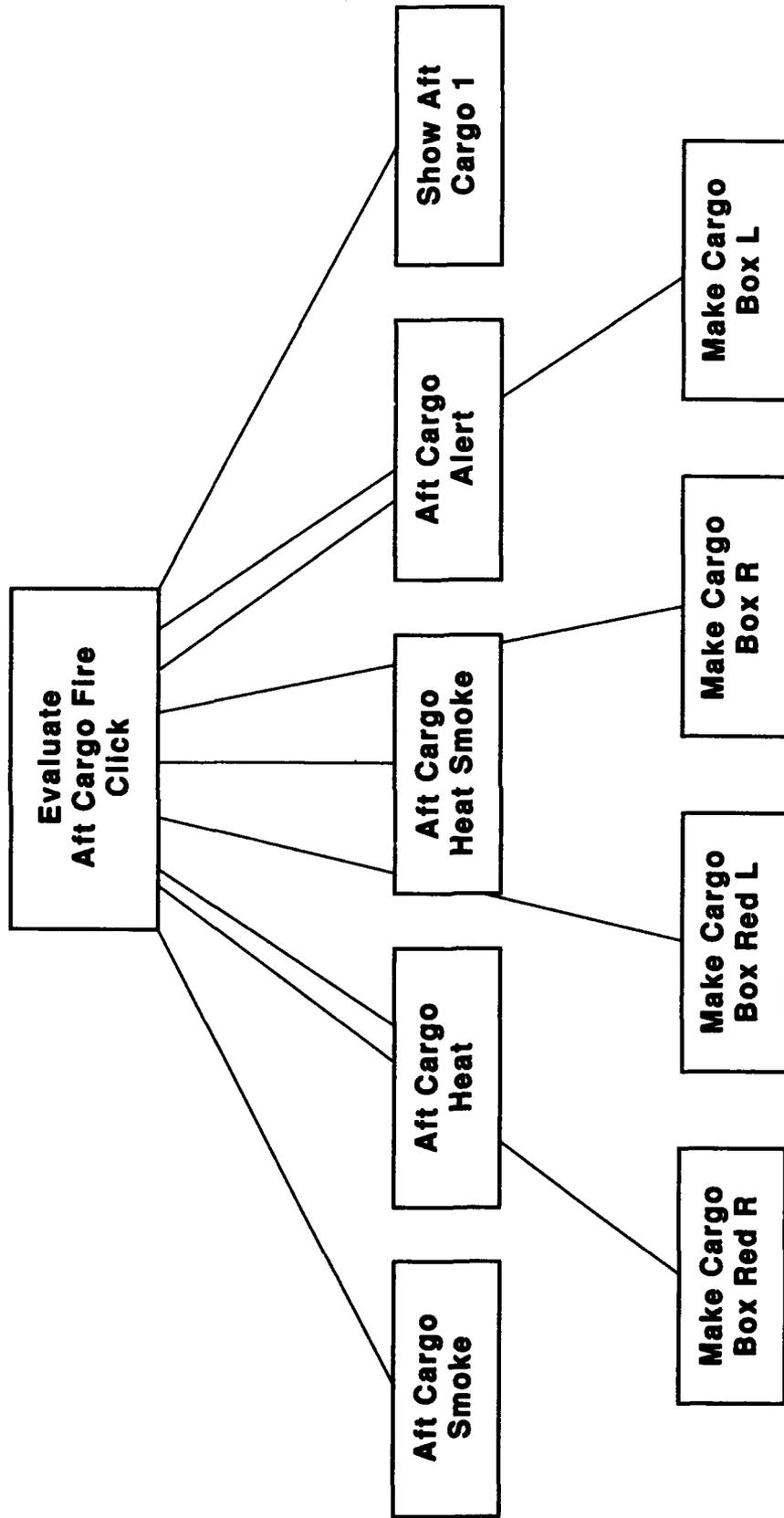

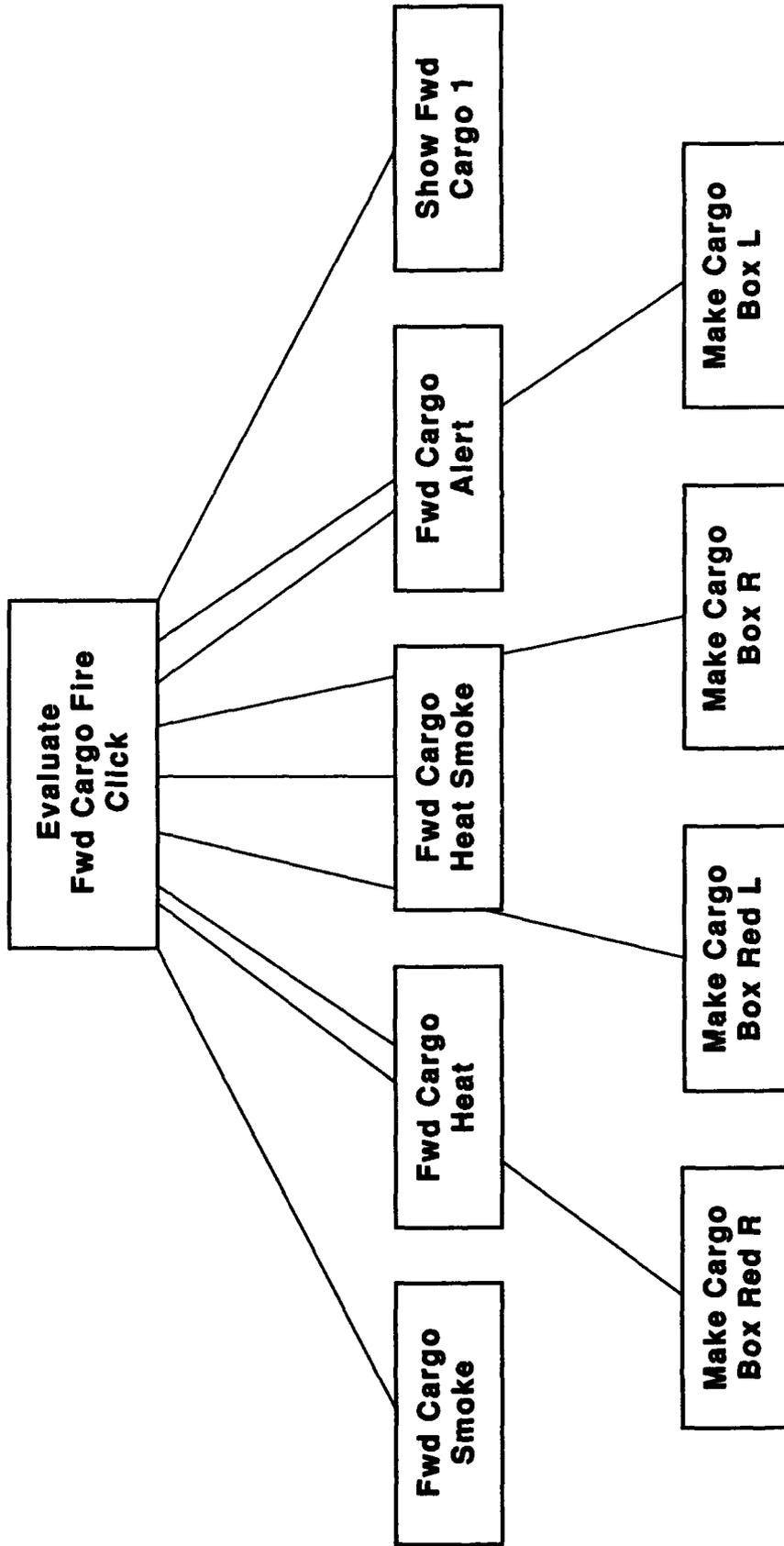

Appendix C

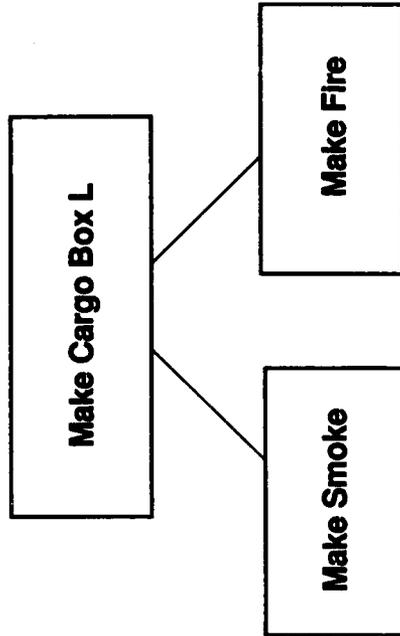
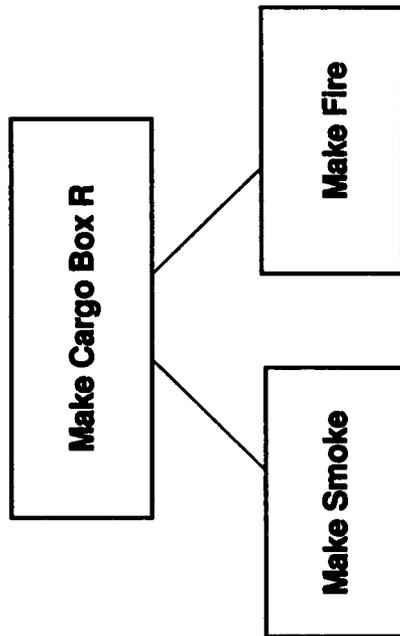
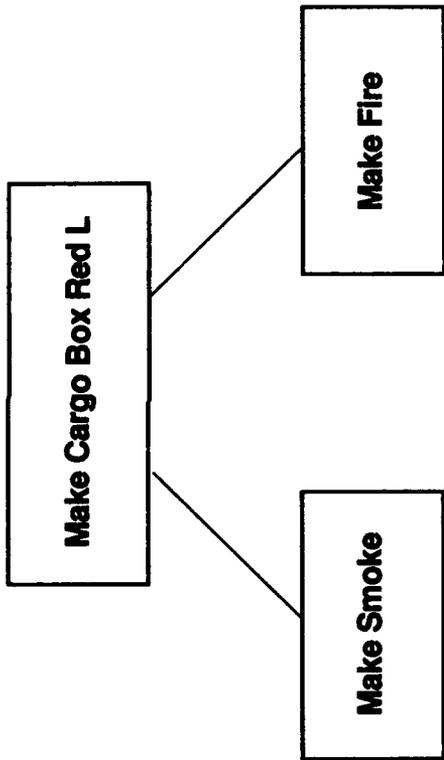

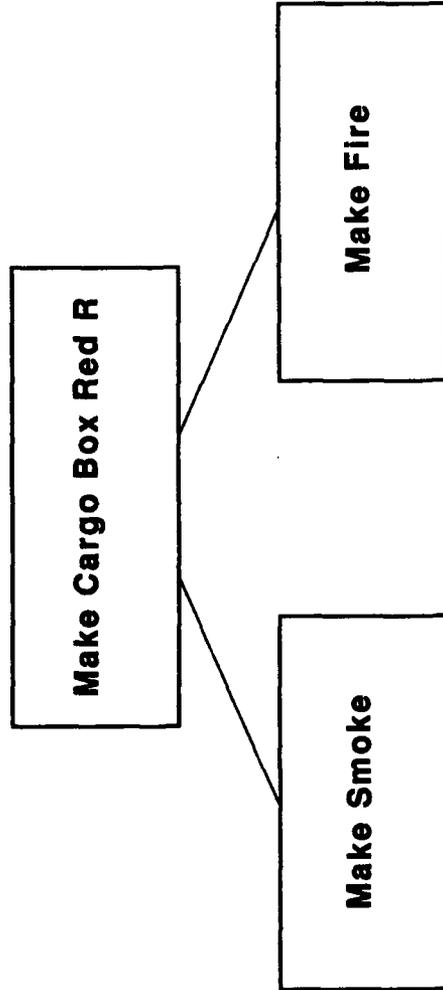
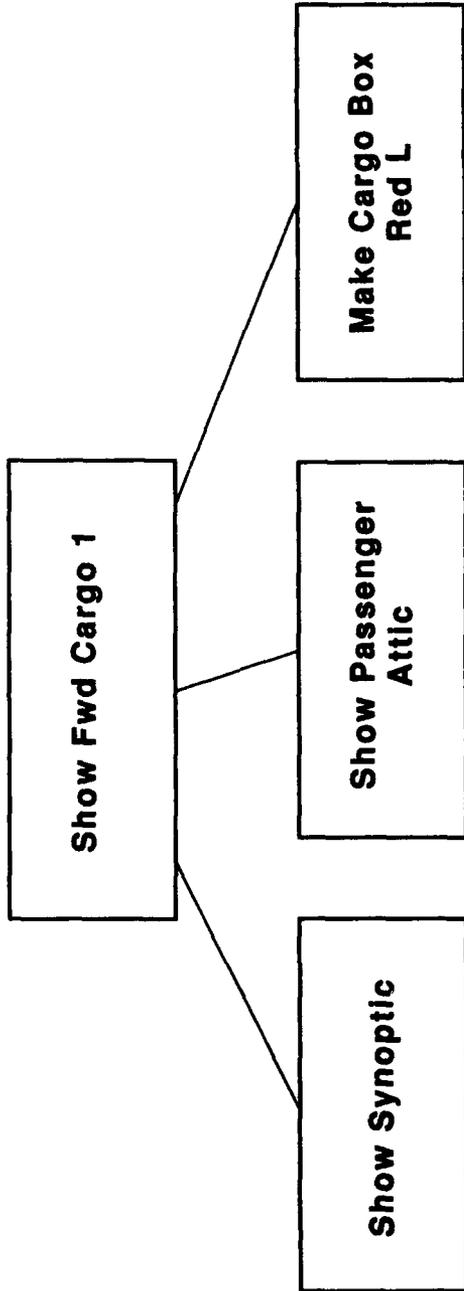

Appendix C

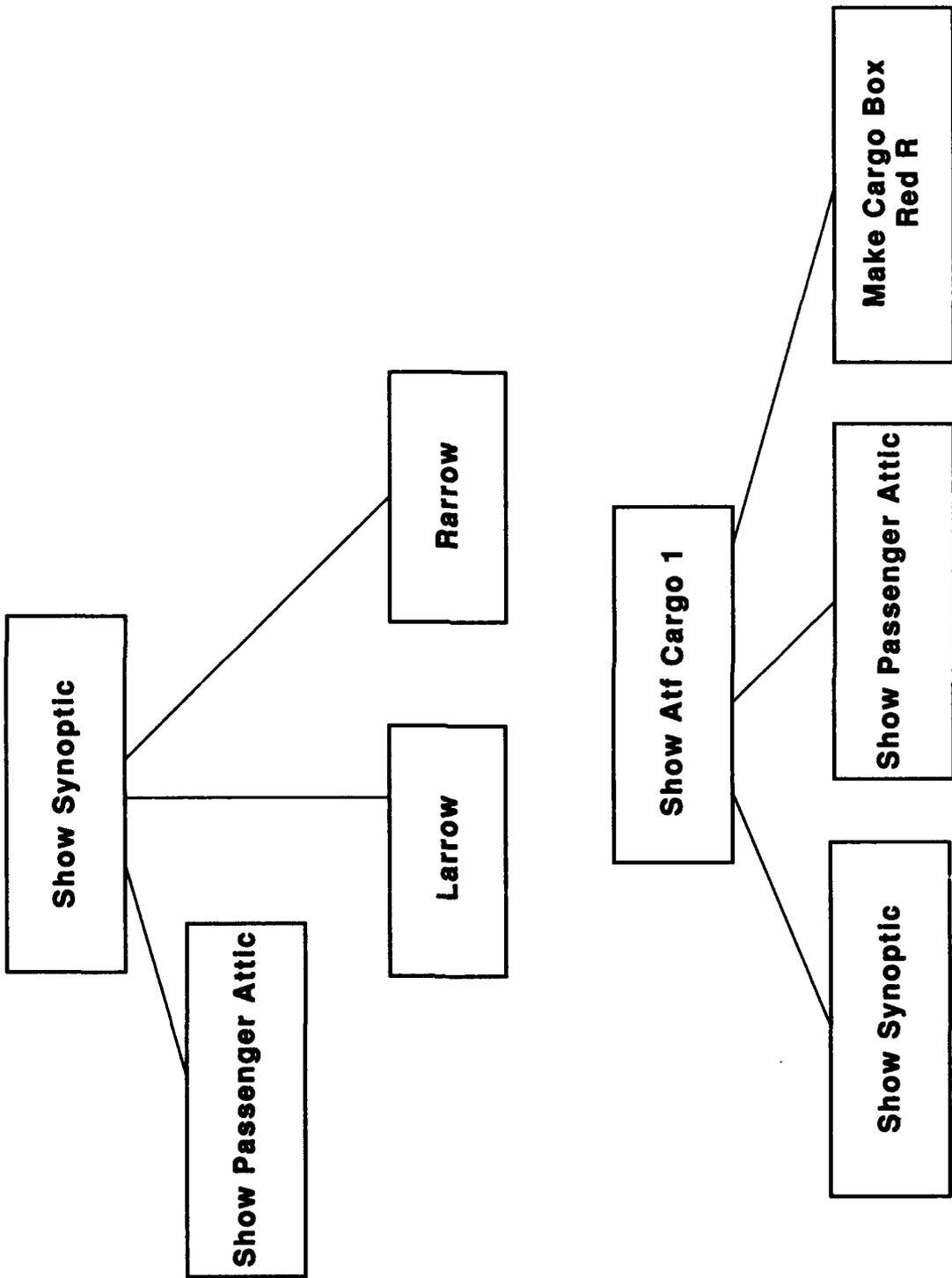

Appendix C

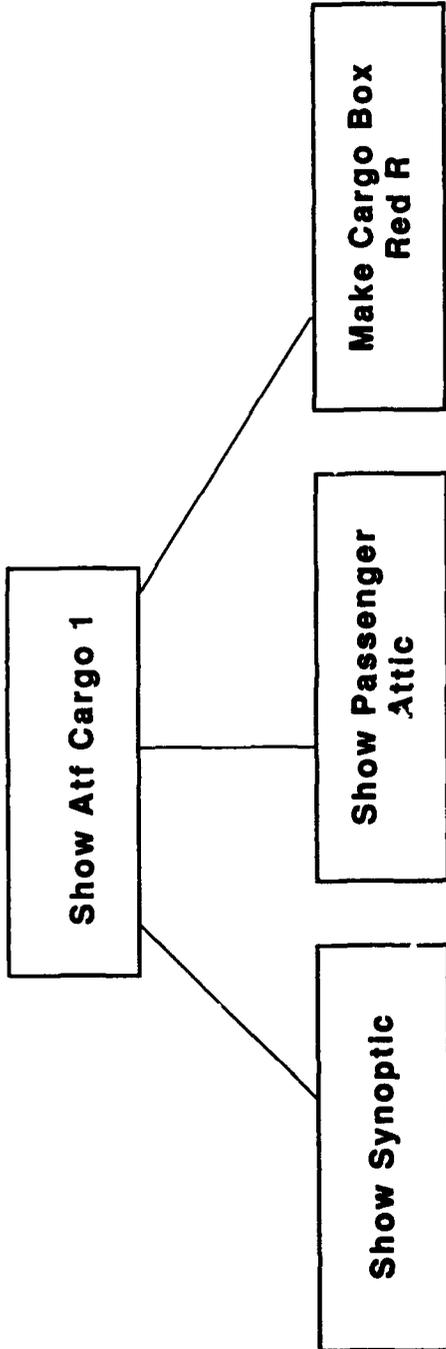

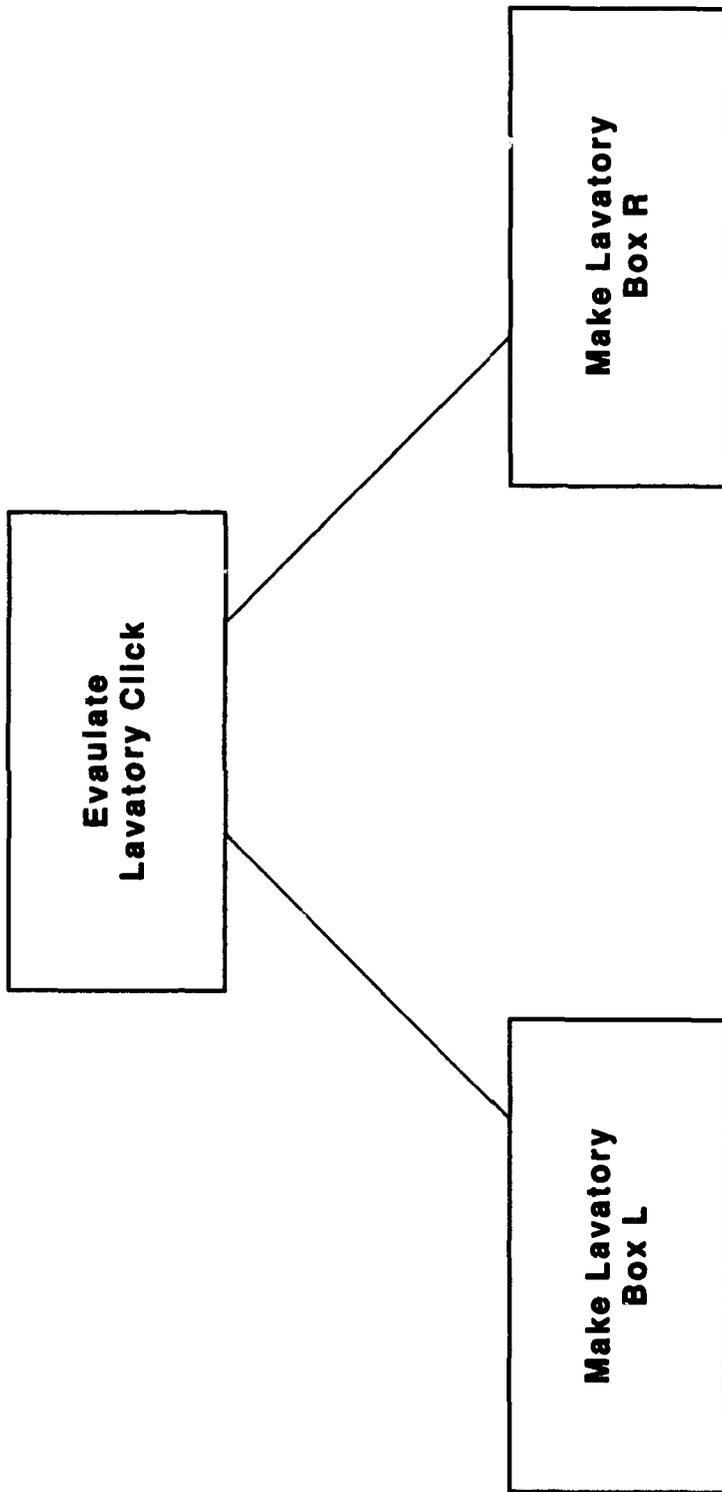

Appendix C