

1

NASA Conference Publication 10058

**S** DTIC  
ELECTE  
JUL 31 1992  
**C**

**AD-A254 966**



**1991**

# **INTERNATIONAL AEROSPACE AND GROUND CONFERENCE ON LIGHTNING AND STATIC ELECTRICITY**

Volume II of II

Proceedings of a conference sponsored  
by NASA John F. Kennedy Space Center  
and held at Cocoa Beach, Florida, USA  
April 16-19, 1991.

DISCONTINUED PUBLICATION  
ANNOUNCED BY THE  
PUBLISHERS

92 083

424704  
92-20569 12 pgs

**A SIMULATED LIGHTNING EFFECTS TEST FACILITY  
FOR TESTING LIVE AND INERT MISSILES AND  
COMPONENTS**

Jeffery D. Craven, James A. Knaur, and Truman W. Moore, Jr.  
Dept. of the Army, Redstone Technical Test Center, Redstone Arsenal, Al. Per Form 50

Thomas H. Shumpert  
Auburn University, Auburn, Al.

Accession For	
NTIS	✓
DTIC TAB	
Unannounced	
Justification	
Distribution/	
Availability Co	
Dist	Avail and/c Special
A-1	

### ABSTRACT

Details of a simulated lightning effects test facility for testing live and inert missiles, motors, and explosive components is described. The test facility is designed to simulate the high current, continuing current, and high rate-of-rise current components of an idealized direct strike lightning waveform.

The Lightning Test Facility has been in operation since May, 1988, and consists of three separate capacitor banks used to produce the lightning test components, a permanently fixed, large, steel safety cage for retaining the item under test should it be ignited during testing, an earth covered bunker housing the control/equipment room, a charge/discharge building containing the charging/discharging switching, a remotely located blockhouse from which the test personnel control hazardous testing, and interconnecting cables.

### I. INTRODUCTION

One of the problems associated with simulated lightning testing of inerted missiles and inerted explosive items containing electrically initiated explosive trains is to determine the interaction of the propellants and explosives with the simulated lightning environment. There have been concerns raised in the past that propellants and explosive materials may be susceptible to the indirect effects (radiated fields) of lightning. The large missile lightning test facility was designed and built to simulate lightning strikes on missiles and other items which contain less than 100 pounds of detonable material up to several thousand pounds of propellant materials. The primary objective of testing at this facility is to determine whether a hazard exists to personnel or area equipment should the Unit Under Test (UUT) be struck by lightning. These tests may also be conducted on shipping containers containing live missiles to determine if hazards exist in stockpile or shipping configurations. The secondary objective of this testing is to determine whether the UUT suffers major damage which prevents its use or which requires extensive repairs before it can be used.

### II. IDEALIZED DIRECT STRIKE LIGHTNING WAVEFORM

The test facility is designed to simulate components A (high current), C (continuing current), and D (high  $\partial I/\partial t$ ) of the direct strike lightning idealized current test waveform shown in Figure 1 [1 and 2]. These

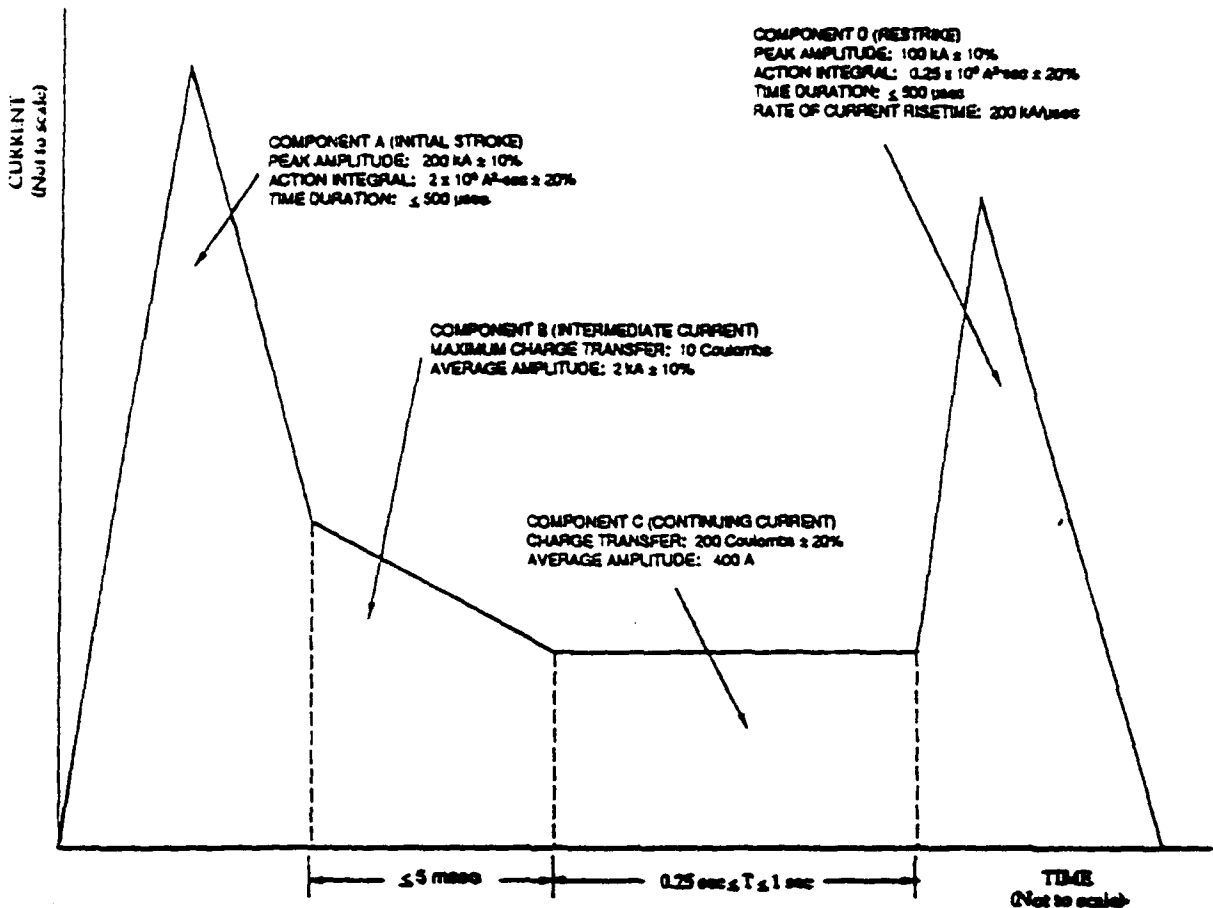

**Figure 1. Idealized Direct Strike Lightning Waveform.**

components are intended to reproduce the significant effects of the natural environment and are therefore independent of vehicle type or configuration. The idealized component specifications are as follows:

**High Current:**      Peak current = 200 kA  $\pm$  10%  
                                  Action integral,  $\int I^2 dt = 2 \times 10^6 \text{ A}^2 \text{ sec} \pm 20 \%$   
                                  Time duration  $\leq 500 \mu\text{s}$

**Continuing Current:** Charge transfer = 200 C  $\pm$  20%  
                                  Average amplitude = 400 A  
                                  Time duration:  $0.25 \text{ sec} \leq T \leq 1 \text{ sec}$

**High  $\partial I/\partial t$ :**      Peak amplitude = 100 kA  $\pm$  10%  
                                  Action integral,  $\int I^2 dt = 0.25 \times 10^6 \text{ A}^2 \text{ sec} \pm 20\%$   
                                  Current rate - of - rise =  $2 \times 10^{11} \text{ A/sec} \pm 10\%$   
                                  Time duration  $\leq 500 \mu\text{s}$

### III. DESCRIPTION OF THE TEST FACILITY

The test facility consists of three separate capacitor banks to produce the lightning test components, a permanently fixed large steel safety cage for retaining the unit under test should it be ignited during test, an earth covered bunker housing the control/equipment room, a charge/discharge building containing the charging/discharging switching, a remotely located blockhouse from which test personnel control hazardous testing, and interconnecting cables (see Figure 2). The safety cage is designed to retain large missiles should they become propulsive during test. A smaller, removable secondary cage can be installed inside the larger cage to retain smaller test items. The high current and continuing current components are normally simulated simultaneously in one test event, and the high  $\partial I/\partial t$  component is simulated in a separate test event (see Figures 3, 4, 5, and 6 for block diagrams of the systems).

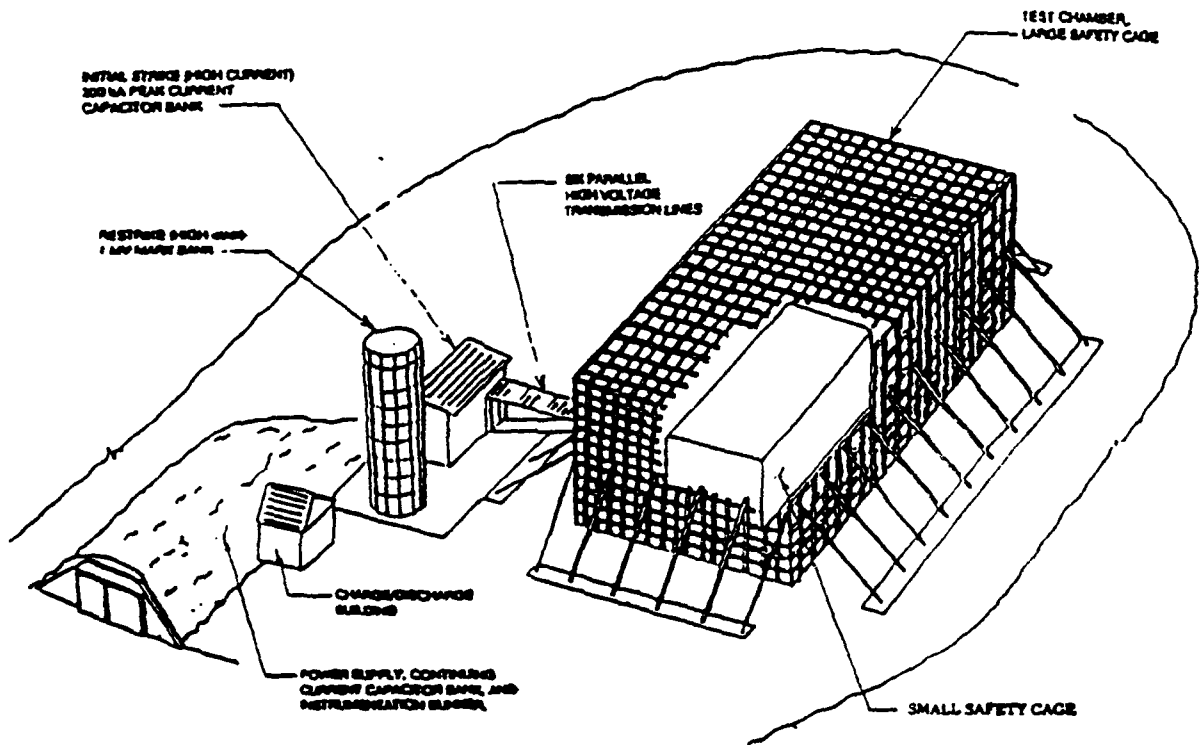
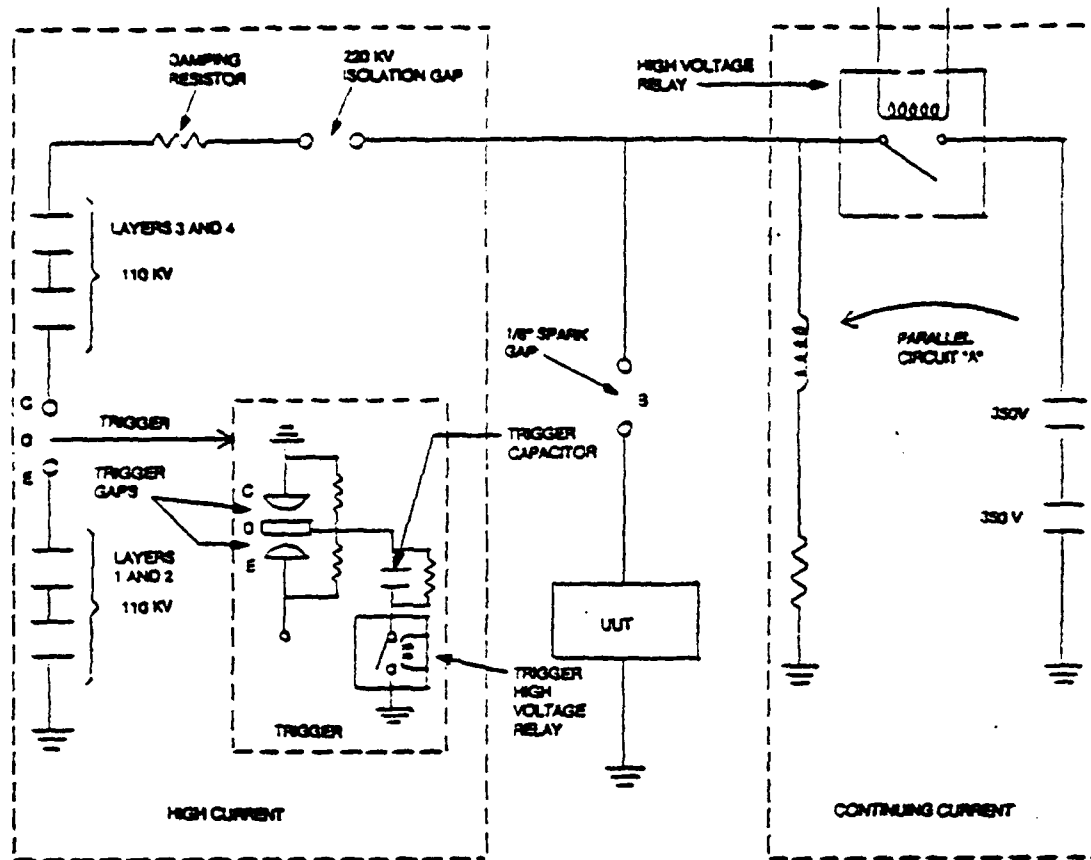

Figure 2. Test Facility Overview.

#### A. HIGH CURRENT SYSTEM

The high current system, Figure 4, consists of 480 capacitors each rated at 60 kV and 1.875  $\mu\text{F}$ . It is constructed in 4 layers with 120 capacitors in



- NOTES:
1. Charge each of the 480 capacitors in the high current bank, 1.875  $\mu\text{F}$  per capacitor, to 55 kV, and charge each of the 392 capacitors in the continuing current bank, approximately 3000  $\mu\text{F}$  per capacitor, to 400 V.
  2. Activate the continuing current to start current flow in parallel circuit "A". 20 ms later the high current is activated. After the high current breaks down a path across B, an 1/8" spark gap, the continuing current flows across the gap into the UUT.

**Figure 3. High Current/Continuing Current Abbreviated Schematic.**

parallel on each layer. Layers 1 and 2 are connected in series, as are layers 3 and 4. Each layer consists of 10 removable modules with 12 capacitors per module. Individual capacitors are fused in order to prevent the entire bank from dumping into a capacitor fault. Layers 1 and 2 and layers 3 and 4 are charged in parallel to approximately 110 kV and discharged in series to form a two-stage Marx bank with an output voltage of 220 kV. The bank is fired by a triggered spark gap located between layers 2 and 3. An output isolation gap is located above layer 4 to isolate the load from the bank. A damping resistor is also located above layer 4; it consists of three Franklin 60 kV, 240 kJ resistors connected in series, providing a total resistance of 0.63 ohms. The bank is charged by power supplies whose leads are routed through a switching system located in the Charge/Discharge Building, where charging

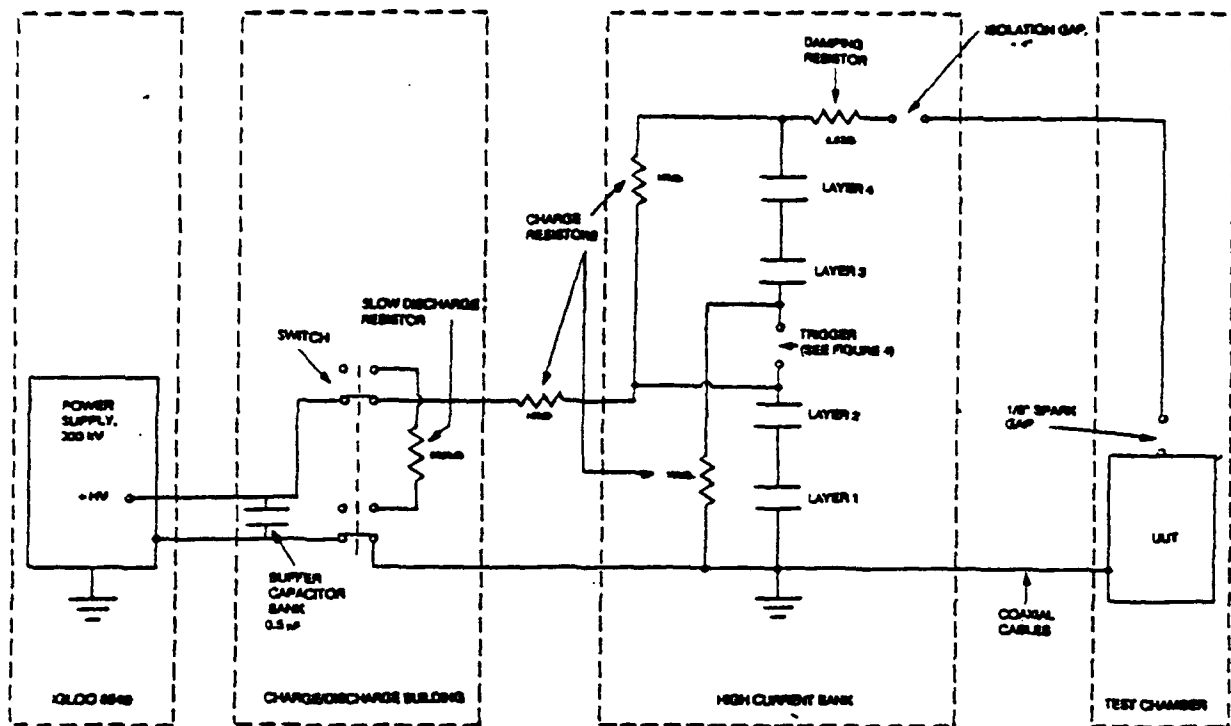

Figure 4. High Current System Schematic.

and slow discharging of the bank can be accomplished by remotely operated pneumatic switches.

The high current bank is fired by the triggered spark gap located between capacitor layer 2 and layer 3 about 20 ms after the continuing current circuit is activated. The trigger center electrode is pulled to ground potential by the high voltage relay causing an overvoltage of the other half of the gap.

The high current/continuing current transmission lines must penetrate the safety cages, which are electrically conductive and grounded, without loss of current. This transmission system consists of six large parallel high voltage cables connected to ten smaller high voltage cables. The large cables penetrate the large safety cage and the smaller cables penetrate the secondary safety cage. The smaller cables can be routed within the secondary safety cage to the desired test location on the UUT. The center conductors of these cables are tied to a tungsten probe tip. During testing for these current waveform components, the probe tip is placed one eighth inch from the test item, and the current return path to the generator is through the coax shields. During this test, the UUT must be isolated from the ground plane and safety cage walls to assure that the entire current load returns via the coax shields.

## B. CONTINUING CURRENT SYSTEM

The continuing current bank, Figure 5, consists of two layers of electrolytic capacitors connected in series. Each layer contains one hundred ninety six 450 V, 3000  $\mu\text{F}$  capacitors in parallel. The total measured capacitance is 0.37 F when charged to a nominal value of 750 V. This bank is charged with a 1000 V, 5 A power supply. The charge leads are connected to the capacitor bank via a charge relay mounted on the bank. This bank is fired with a high voltage relay, triggered by a pneumatic switch, which triggers a high voltage relay to fire the high current bank. The current flows via connecting cables to the high current bank coaxial cables and thence to the UUT. An 8 mH inductive parallel circuit at the load stores the continuing current energy until the high current bank discharges and ionizes the air at the spark gap. This small, approximately 1/8 inch gap isolates the current from the UUT. After approximately 20 ms, the high current bank is fired and arcs across this gap, thus allowing the continuing current to flow from the parallel circuit to the UUT. Slow discharging can be accomplished by manually closing a switch on the bank, which places a large resistive load on the capacitors.

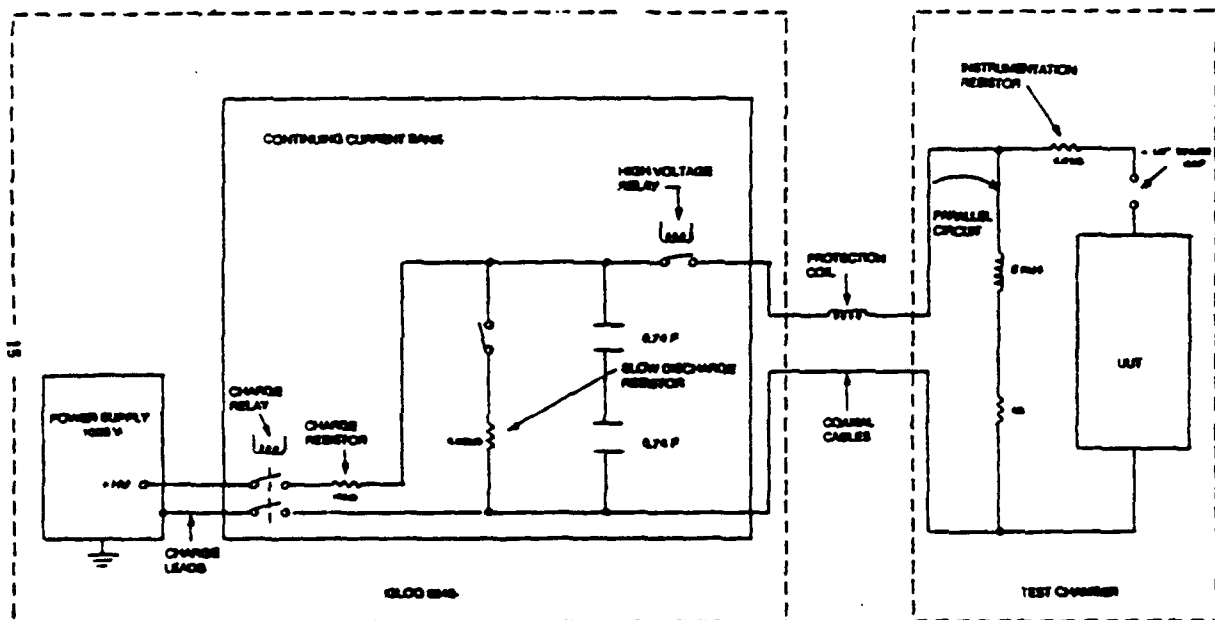

Figure 5. Continuing Current System Schematic.

## C. High $\partial I/\partial t$ SYSTEM

The high  $\partial I/\partial t$  bank, Figure 6, is an 18 stage Marx bank with a total capacitance of 0.9375  $\mu\text{F}$ . Each stage, consisting of nine 60 kV, 1.875  $\mu\text{F}$  capacitors in parallel, is normally charged to 42 kV to provide a total output voltage of 756 kV. The 18 stages are charged in parallel via a group of charge resistors by a 100 kV power supply. Charging is activated with a remotely operated pneumatic switch, located in the Charge/Discharge Building. The

bank is triggered remotely by a pneumatic switch. The trigger pulse is divided resistively and delivered to the first 4 spark gaps in the large Marx bank. The bank can be slowly discharged in the Charge/Discharge Building by switching in a large resistive load to ground.

Energy from the Marx bank is delivered to the peaking capacitor/spark gap assembly via a one-inch insulated conductor. The insulated conductor runs from the high  $\partial I/\partial t$  bank isolation gap to the top of the peaking capacitor/spark gap assembly large corona ring inside the large safety cage. The peaking capacitor bank has a total capacitance of  $0.027 \mu\text{F}$  and a maximum voltage capability of 2.2 MV. The peaking capacitor bank consists of two parallel stacks of Maxwell capacitors. Each stack contains twenty two  $0.3 \mu\text{F}$ , 100 kV capacitors in series. The secondary frequency created by the peaking capacitor increases the risetime of the pulse to meet the  $200 \text{ kA}/\mu\text{s}$  requirement.

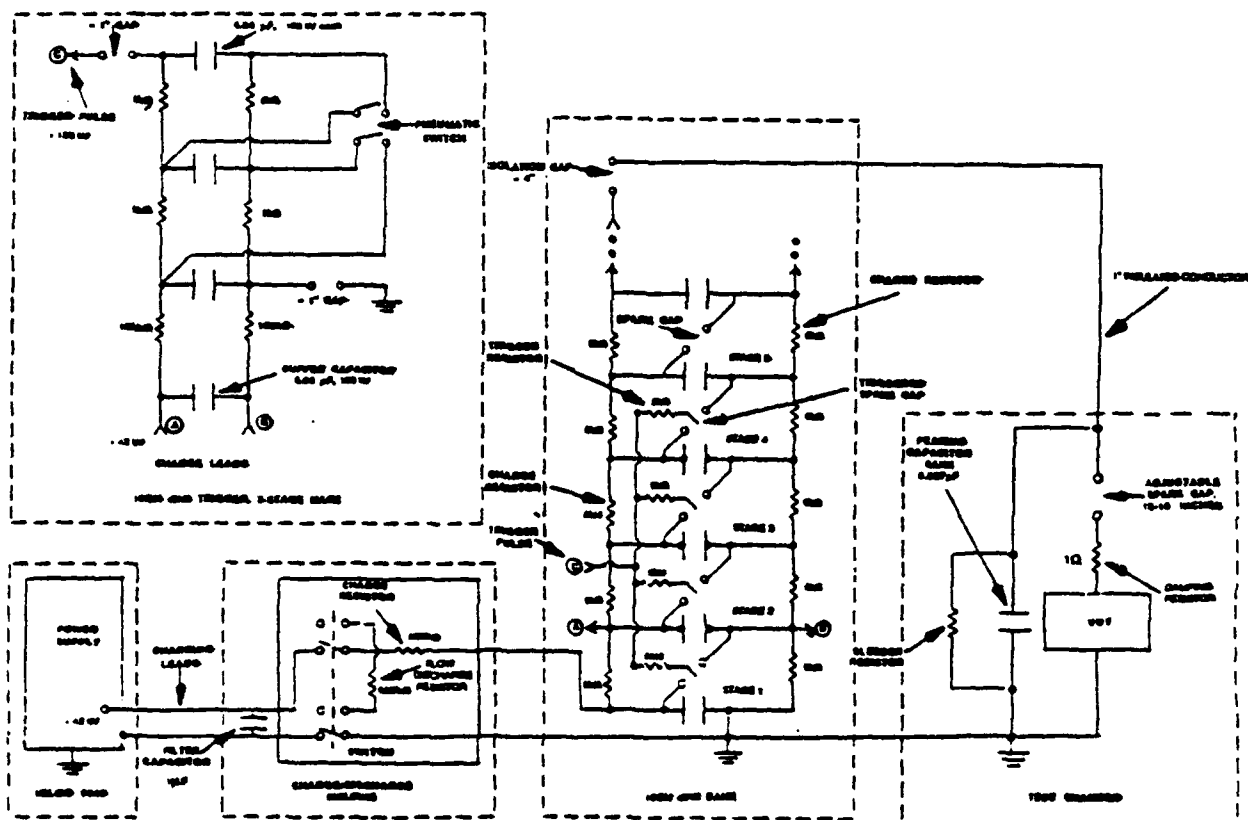

Figure 6. High  $\partial I/\partial t$  System Schematic.

The peaking capacitor circuit utilizes a large spark gap located above the secondary safety cage. This spark gap spacing determines the peak current and rate-of-rise of the test current waveform. A down-conductor, extending through the secondary safety cage, is attached directly to the test item. A one ohm damping resistor is located between the spark gap and the UUT.



#### IV. DATA ACQUISITION AND SYSTEM CALIBRATION

Calibration waveforms for the high-current, continuous current, and high  $\partial I/\partial t$  current components of the simulated lightning waveform are obtained by connecting a load of known impedance to the output of the generator and measuring the current that flows through it. Separate instrumentation is required for each of the lightning component waveforms. Instrumentation to monitor the high current and high voltage component waveforms is identical, though, except for the attenuation/gain settings on the fiber optic receivers (see Figures 7, 8, and 9 for waveforms from an actual test). The equipment used to generate and record these measurements is as follows:

##### A. HIGH CURRENT INSTRUMENTATION

A Pearson Model 1080 Current Probe (400 Amps/Volt, 200 kA max.) is utilized as the sensor for the high current waveform measurement, Figure 7. The current probe is installed on the center conductor of the High Current/Continuing Current Discharge Probe. The high current waveform measurement is telemetered via a Nanofast Model OP-300 Fiber Optic System (Self-calibrating with a 1 volt, 1 MHz square wave signal). The signal

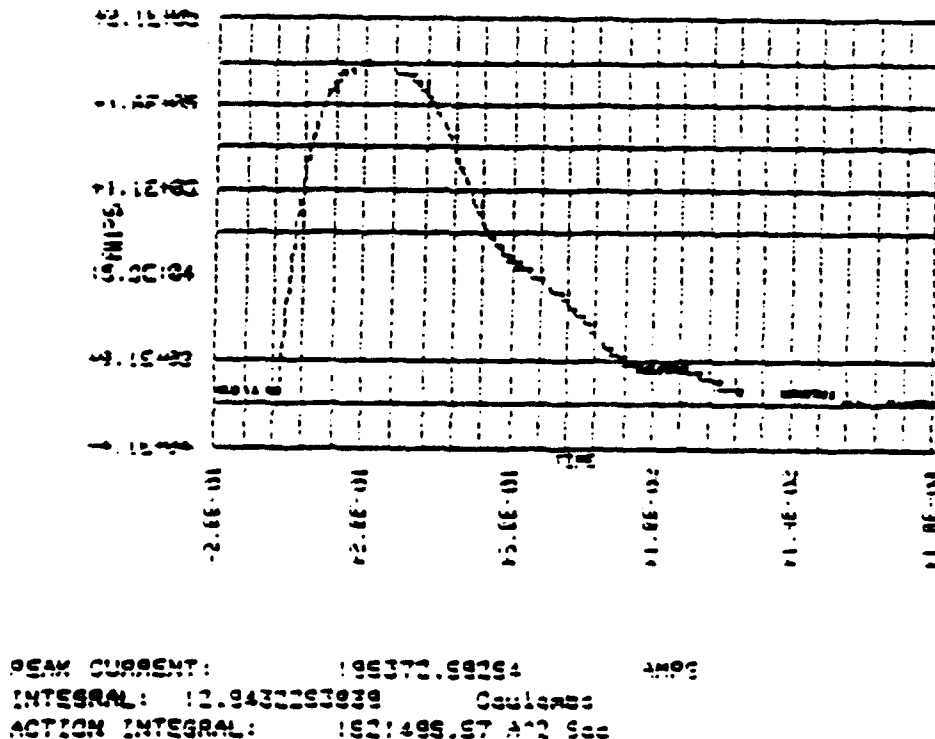

Figure 7. High Current Component Waveform Measurement.

can be recorded on a Hewlett-Packard Digitizing Oscilloscope (Model 54111D, 54200D, or 54510A) or a Tektronix Programmable Digitizer (Model 7612D or 7912A/D) and reduced on a Hewlett-Packard Model 9000 PC 308 Vectra Computer with a Hewlett-Packard Model 9122 Disk Drive.

## B. CONTINUING CURRENT INSTRUMENTATION

An in-house designed 0.01 ohm Nichrome ribbon series resistor (100 Amps/volt) is utilized as the sensor for the continuing current waveform measurement, Figure 8. The Nichrome resistor is installed in-line with the continuing current transmission line. The continuing current waveform measurement is telemetered via a Meret Model MDL281-4-C Fiber Optic System. The signal can be recorded on a HP Digitizing Oscilloscope (Model 54111D, 54200D, or 54510A) or a Tektronix Programmable Digitizer (Model 7612D or 7912A/D) and reduced on an HP Model 9000 PC 308 Vectra Computer with an HP Model 9122 Disk Drive. The continuous current measurement system is calibrated by flowing a known DC current through the series resistor and recording the output of the HP Oscilloscope.

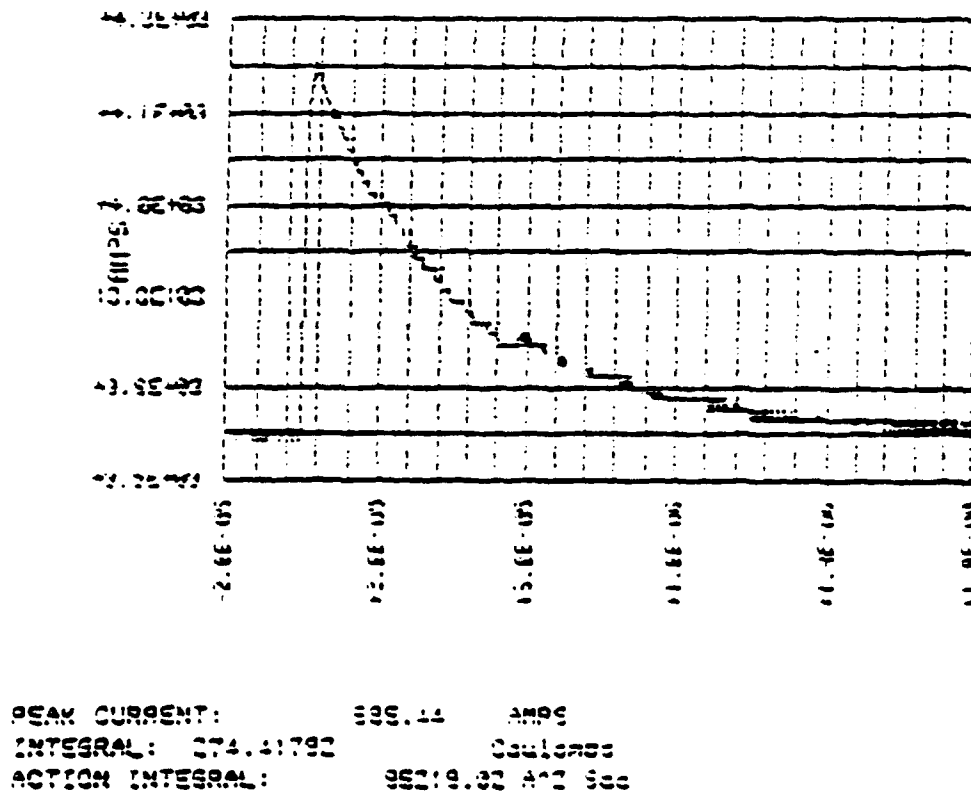

Figure 8. Continuing Current Component Waveform Measurement.

## C. HIGH $dI/dt$ INSTRUMENTATION

A Pearson Model 1080 Current Probe is utilized as the sensor for the high rate-of-rise current waveform measurement, Figure 9. The current probe is installed on the center conductor of the High Voltage Down Conductor. The

high voltage waveform measurement is telemetered via a Nanofast Model OP-300 Fiber Optic System. The signal can be recorded on a HP Digitizing Oscilloscope (Model 54111D, 54200D, or 54510A) or a Tektronix Programmable Digitizer (Model 7612D or 7912A/D) and reduced on an HP Model 9000 PC 308 Vectra Computer with an HP Model 9122 Disk Drive.

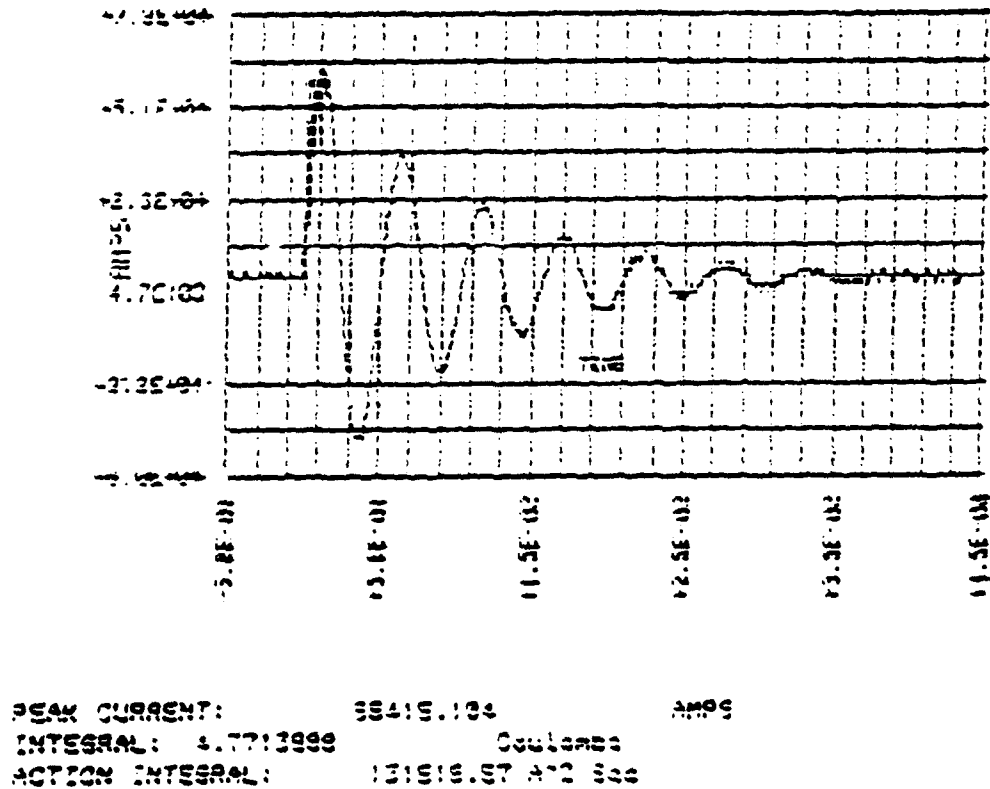

Figure 9. High  $dI/dt$  Component Waveform Measurement.

### V. CONCLUDING REMARKS

A simulated lightning test facility for testing live and inert missiles and components has been described. Although primarily designed for testing live missiles, this facility can be used to test inert hardware which could be susceptible to the effects of lightning, such as military vehicles and components, and aerospace hardware.

## DISCLAIMER

Use of trade names or manufacturers in this report does not constitute an official endorsement or approval of the use of such commercial hardware or software.

## REFERENCES

- [1] MIL-STD-1757A, Lightning Qualification Test Techniques for Aerospace Vehicles and Hardware, 20 July, 1983.
- [2] "Operating Procedures, Test Area 5 Large Missile Lightning Test Facility, MICOM Special Report SR-RD-TE-90-11, December 1989, prepared by Kenneth K. Mitchell COLSA, INC.