

AD-A250 766



①

**7th International Conference
on
Partitioning in
Aqueous Two-Phase Systems**

DTIC
ELECTE
MAY 13 1992
S C D

**Advances in Separation
in Biochemistry
Cell Biology and Biotechnology**

June 2-7, 1991

New Orleans, Louisiana

... U.S.A. ...

92-12773



INFORMATION STATEMENT A
Approved for public release;
Distribution Unlimited

92 5 12 042

REPORT DOCUMENTATION PAGE

Form Approved
OMB No. 0704-0188

1a. REPORT SECURITY CLASSIFICATION Unclassified		1b. RESTRICTIVE MARKINGS None	
2a. SECURITY CLASSIFICATION AUTHORITY		3. DISTRIBUTION / AVAILABILITY OF REPORT Unlimited	
2b. DECLASSIFICATION / DOWNGRADING SCHEDULE			
4. PERFORMING ORGANIZATION REPORT NUMBER(S) n/a		5. MONITORING ORGANIZATION REPORT NUMBER(S)	

6a. NAME OF PERFORMING ORGANIZATION University of AL/Huntsville	6b. OFFICE SYMBOL (If applicable)	7a. NAME OF MONITORING ORGANIZATION Department of the Navy	
6c. ADDRESS (City, State, and ZIP Code) The University of AL in Huntsville Huntsville, AL 35899		7b. ADDRESS (City, State, and ZIP Code) Office of Naval Research, Atlanta Area Off Georgia Institute of Technology, 206 O'Keefe Bldg., Atlanta, GA 30332	

8a. NAME OF FUNDING / SPONSORING ORGANIZATION Department of the Navy	8b. OFFICE SYMBOL (If applicable)	9. PROCUREMENT INSTRUMENT IDENTIFICATION NUMBER	
8c. ADDRESS (City, State, and ZIP Code) Office of Naval Research, Code 1511:LG 800 North Quincy Street Arlington, VA 22217-5000		10. SOURCE OF FUNDING NUMBERS	
		PROGRAM ELEMENT NO.	PROJECT NO.
		TASK NO.	WORK UNIT ACCESSION NO.

11. TITLE (Include Security Classification)
The 7th International Conference on Partitioning in Aqueous Polymer Two-Phase Systems

12. PERSONAL AUTHOR(S)
J.Milton Harris, Editor

13a. TYPE OF REPORT Final	13b. TIME COVERED FROM 3/28/91 TO 9/30/92	14. DATE OF REPORT (Year, Month, Day) 1991/06/2-7	15. PAGE COUNT 97
------------------------------	--	--	----------------------

16. SUPPLEMENTARY NOTATION

17. COSATI CODES			18. SUBJECT TERMS (Continue on reverse if necessary and identify by block number)
FIELD	GROUP	SUB-GROUP	

19. ABSTRACT (Continue on reverse if necessary and identify by block number)

This is the detailed report and proceedings from The 7th International Conference on Partitioning in Aqueous Two-Phase Systems: Advances in Separation in Biochemistry Cell Biology and Biotechnology, June 2-7, 1991, New Orleans, Louisiana, U.S.A.

20. DISTRIBUTION / AVAILABILITY OF ABSTRACT <input checked="" type="checkbox"/> UNCLASSIFIED/UNLIMITED <input type="checkbox"/> SAME AS RPT <input type="checkbox"/> DTIC USERS	21. ABSTRACT SECURITY CLASSIFICATION Unclassified	
--	--	--

22a. NAME OF RESPONSIBLE INDIVIDUAL	22b. TELEPHONE (Include Area Code)	22c. OFFICE SYMBOL
-------------------------------------	------------------------------------	--------------------

To our Sponsors!

The organizers gratefully acknowledge the following sponsors for their financial support which has considerably assisted in reducing costs to delegates:

EM Science

Eli Lilly

Genentech

Merck, Sharp & Dohme

Miles Laboratories

Pharmacia

Pharma-Tech Research

Reppe Glykos

Union Carbide

Universities Space Research Association

Air Force Office of Scientific Research

National Science Foundation

National Aeronautics and Space Administration

Office of Naval Research



Accession For	
NTIS GPO	<input checked="" type="checkbox"/>
DTIC TAB	<input type="checkbox"/>
Unannounced	<input type="checkbox"/>
Justification	
By	
Distribution/	
Availability Codes	
Dist	Avail and/or Special
A-1	

Conference Organizers:

Local Organizers

Milton Harris
University of Alabama in Huntsville
Huntsville, Alabama 35899

Laurel Karr
Marshall Space Flight Center
Huntsville, Alabama 35812

International Committee

P. -Å. Albertsson (Sweden)
D. E. Brooks (Canada)
D. Fisher (United Kingdom)
G. Johansson (Sweden)
M. -R. Kula (Germany)
W. Müller (Germany)
I. A. Sutherland (United Kingdom)
H. Walter (United States)

North American Committee

F. Arnold (Caltech)
D. E. Brooks (UBC)
H. Cabezas (Arizona)
M. A. Eiteman (Georgia)
T. A. Hatton (MIT)
J. Hsu (Lehigh)
D. J. and D. M. Morré (Purdue)
J. M. Van Alstine (UAH)
H. Walter (Veteran's Administration)

PROGRAM

Program

Sunday Evening

Registration
Reception

Monday Morning

Continental Breakfast
Session 1, Partitioning of Macromolecules
Poster Session 1

Noon

Lunch

Monday Afternoon

Session 2, Biotechnical Applications of Partitioning
Poster Session 2

Tuesday Morning

Continental Breakfast
Session 3, Partitioning of Cells and Fragments

Noon

Lunch

Tuesday Afternoon

Session 3, continued
Poster Session 3
Session 4, Biotechnical Applications of PEG Chemistry

Wednesday Morning and Afternoon

Boat Trip (including lunch)

Wednesday Evening

Session 5, Theory of Partitioning and Characterization of Phase Behavior

Thursday Morning

Continental Breakfast

Session 6, Gravitational Effects of Separation Related Processes

Poster Session 4

Session 7, Polymer-Protein and Polymer-Surface Interactions

Noon

Lunch

Thursday Afternoon

Session 8, Novel and Complementary Techniques

Poster Session 5

Thursday Evening

Business Meeting

Banquet

Friday Morning

Continental Breakfast

Session 8, continued

Detailed Program

Monday, Continental Breakfast 7:30 (outside meeting room)

8:20–12:00 Session 1, Partitioning of Macromolecules

8:20 Introduction - Per Åke Albertsson, session chair

8:25 (#1) G. Birkenmeier, A. Otto, B. Sulk, G. Kopperschläger, H.G. Botros, M.A. Vijayalakshmi, T. Stigbrand, P.E. Jensen, "Immobilized metal ion affinity partitioning (IMAP) of proteins and cells"

8:55 (#2) K. Köhler, C. Ljungquist, A. Kondo, B. Nilsson, A. Veide, "Tryptophan-rich peptide handles to increase the partition coefficient of proteins in PEG/potassium phosphate aqueous two-phase systems"

9:25 (#3) G. C. Terstappen, M.R. Kula, "Partitioning of proteins in detergent-based aqueous two-phase systems"

9:45–10:35 Poster Session #1 and Coffee Break

(#4) P.Å. Albertsson, A. Persson, "A novel method for purification of plastocyanin"

(#5) A. Blennow, G. Johansson, "Starch synthesizing enzymes, isolated and studied by phase partitioning"

(#6) C.-H. Lin, M.-H. Lin, "Isolation and purification of penicillin G acylase from disrupted *E. coli* by two phase method"

(#7) S. Nielsen, J.A. Asenjo, "Partitioning and purification of monoclonal antibodies in aqueous two-phase systems"

(#8) F.D. Raymond, D. Moss, D. Fisher, "Partitioning detects differences in the released forms of alkaline phosphatase (ALP), a GPI-anchored protein"

(#9) Z.-Y. Shen, M. Cong, J.-C. Yang, "Extraction of interferon- γ using PEG/potassium phosphate aqueous two-phase system."

(#10) A.B. Silva, P.N. Pissarra, M.C. Arrabaca, "Optimization of the extraction of C4-phospho(enol) pyruvate carboxylase, using aqueous two-phase systems"

(#11) S.M. Snyder, K.D. Cole, "Ionic strength dependence of the solubility in aqueous two-phase systems and polyethylene glycol solutions of lipoxygenase in crude mixtures and in purified form"

(#12) M. H. Hariri, G.A. Mansoori, P. Todd, "Protein separation using aqueous two-phase partitioning"

Session 1 (Continued)

Göte Johansson, session chair

10:35 (#13) G. Kopperschläger, A. Otto, G. Lorenz, "Partitioning of streptokinase in aqueous two-phase systems application to the purification of the protein"

11:05 (#14) G. Johansson, M. Joelsson and L. Cheng, "Methods for steering the partitioning of proteins"

11:35 (#15) J. Luther, C.E. Glatz, "Enhanced partitioning in aqueous two-phase systems using genetically engineered β -galactosidase"

12:00–2:00 Lunch

Monday Afternoon 2:00–6:00

Session 2, Biotechnical Applications of Partitioning

Folke Tjerneld, session chair

2:00 (#16) K. Hayenga, M. Murphy, R. Arnold, J. Lorch, H. Heinsohn, "Application of two-phase liquid-liquid extraction to the purification of calf chymosin from *Aspergillus niger var. awamori*"

2:30 (#17) B.A. Andrews, S. Nielsen, R. Huang, C. Hodgson, J.A. Asenjo, "Partitioning, separation and purification of three recombinant proteins in aqueous two-phase systems"

3:00 (#18) P.A. Harris, G. Karlström, F. Tjerneld, "Enzyme purification using temperature induced phase formation"

3:30–4:00 Coffee Break

J. A. Asenjo, session chair

4:00 (#19) R. A. Ramelmeier, M.R. Kula, "The evaluation of detergent-based aqueous two-phase systems for the large-scale purification of proteins"

4:20 (#20) K. Köhler, B. Nilsson, A. Veide, "Aqueous two-phase extraction for the recovery of peptide hormones"

4:40 (#21) Y. Guan, X. Wu, T.E. Treffry, T.H. Lilley, "Studies on the isolation of penicillin acylase from *Escherichia coli* by aqueous two-phase partitioning"

Monday Afternoon 5:00—6:00 Poster Session #2

(#22) R. Stewart, P. Todd, "A polyethylene glycol-sodium chloride multiphase system for extraction of acid hydrolysates"

(#23) S. Shimeld, P.T. Sharpe, "Aqueous two-phase partition as a method for detecting downstream targets of developmentally-regulated transcription factors"

(#24) J.A. Flanagan, J.G. Huddleston, A. Lyddiatt, "Design and implementation of a prototype liquid partition process for the recovery of bulk protein fractions from brewery waste"

(#25) C. Hodgson, B.A. Andrews, V. Riveros-Moreno, J.A. Asenjo, "Partitioning and separation of tPA (tissue plasminogen activator) in aqueous two-phase systems"

(#26) G. Ström, B. Målarstig, "Industrial case separation of particulate matter including micro-organisms in waterbased cutting-fluids using aqueous two-phase systems"

(#27) G. Ström, B. Målarstig, "Quantitative determination of microbial biomass in waterbased coolants by means of aqueous two-phase separation combined with turbidity measurements"

(#28) B. Sulk, G. Kopperschläger, G. Birkenmeier, "Application of phase partitioning and thiophilic adsorption chromatography for purification of monoclonal antibodies from cell culture fluid"

(#29) W.-S. Yin, W.-Y. Yang, "The study of aqueous two-phase partition of cephalosporin C from fermentation broth"

Tuesday Morning, Continental Breakfast 7:30 (outside meeting room)

8:20—12:05 Session 3 Partitioning of Cells and Fragments

8:20 Introduction - Harry Walter, session chair

8:25 (#30) M.J. López-Pérez, "Phase partitioning of cerebrocortical synaptosomes"

8:55 (#31) A. Persson, B. Jergil, "Biospecific affinity partitioning of membranes"

Session 3 (continued)

9:15 (#32) P. Å. Albertsson, E. Andreasson, A. Persson, P. Svensson, S-G. Yu, "The domain structure of the photosynthetic membrane as determined by fragmentation and separation analyses"

9:35 (#33) B. Norling, V. Mirzakhaniyan, F. Nilsson, B. Andersson, D.J. Morré, "Isolation of cyanobacterial membranes by two-phase partitioning"

9:55-10:15 Coffee Break

Derek Fisher, session chair

10:15 (#34) G. Ström, B. Målarstig, "A chematozonomic method for classification of asymmetric penicillia by means of cross-partition in aqueous two-phase systems combined with SIMCA pattern recognition analysis"

10:45 (#35) D.J. Watts, J. Williams, M. Gaskell, T.E. Treffry, "Stalk cell differentiation in *Dictyostelium discoideum*"

11:05 (#36) E. Cartwright, P. Harrington, P. T. Sharpe, "Partition of mammalian sperm populations"

11:25 (#37) J. Mendieta, G. Johansson, "Affinity-mediated modifications of electrical properties of cell surface: A new approach in affinity partitioning of biological particles"

11:45 (#38) C. Delgado, D. Fisher, G.E. Francis, J. Luque, J. Mendieta, P. Sancho, "Affinity cell partitioning: Lower limit for receptor (antigen sites) expression and strategies for the extraction of low abundance cells"

12:05-2:00 Lunch

Tim Treffrey, session chair

2:00 (#39) L. Hammar, "Purification of HIV and other retroviruses by extraction in aqueous two-phase systems"

2:20 (#40) R. Huang, B.A. Andrews, N. Burns, J.A. Asenjo, "Partitioning and separation of virus like particles (VLPs) from yeast cell debris using aqueous two-phase systems"

2:40-4:00 Poster Session #3 and Coffee Break

(#41) H. Walter, E.J. Krob, L. Wollenberger, "Partitioning of cells in dextran-poly(ethylene glycol) aqueous phase systems: A study of settling time, vessel geometry and sedimentation effects on the efficiency of separation"

Poster Session #3 (continued)

(#42) M.L. Pascual, T. Muiño-Blanco, J.A. Cebrián-Pérez, M.J. López-Pérez, "Effect of Percoll on the centrifugal countercurrent distribution of frozen bull spermatozoa"

(#43) T.G. Hammond, R. Majewski, D. J. Morré, "Resolution of plasma membrane domains of rat kidney and toad bladder by aqueous two-phase partition and preparative free-flow electrophoresis alone and in combination"

(#44) D. Morré, "Fractionation of rat brain homogenates by aqueous two phase polymer partition"

(#45) S. A. Kempson, M. Abraham, H. Al-Mahrouq, P. Campbell, D. J. Morré, "Isolation and subfractionation of kidney endosomes by aqueous two-phase partitioning in series with preparative free-flow electrophoresis"

(#46) S-G. Yu, P.Å. Albertsson, "A comparative study on two different photosystem II membrane preparations"

(#47) D. J. Morré, A.S. Sandelius, B. Andersson, "Isolation of endoplasmic reticulum and Golgi apparatus from homogenates of spinach leaves by aqueous two-phase partition and sucrose gradient centrifugation"

(#48) D.E. Brooks, R. Norris-Jones, J. Betts, B.B. Findlay, "Correlation between partition and loss of capacity for transepithelial migration in TnphoA mutants of Salmonella choleraesuis"

(#49) L.J. Karr, D.L. Donnelly, A. Kozlowsky, J. M. Harris, "Comparison of reagents for immunoaffinity partition"

(#50) J. M. Harris, A. Kozlowski, "Preparation of cibacron blue F3G-A and procion yellow HE-3G ethylene oxide - propylene oxide copolymer conjugates"

Tuesday Afternoon 4:00-5:50

Session 4, Biotechnical Applications of PEG Chemistry

Milton Harris, session chair

4:00 (#51) J.M. Harris, "Biotechnical and biomedical applications of PEG chemistry"

4:30 (#52) E. Bayer, "Properties of immobilized PEG and applications in biotechnology"

Session 4 (continued)

5:00 (#53) S. Zalipsky, C. Lee, S. Menon-Rudolph, and R. Ezrielev, "New functionalized polyethylene glycols for modification of proteins and glycoproteins"

5:30 (#54) C. Delgado, F. Malik, C. Knüsli, M. Domine, O. Smith, D. Fisher, G. E. Francis, "Fractionation of PEG-GM-CSF preparations by FPLC and identification of individual PEG_n-GM-CSF conjugates by phase partitioning"

Wednesday Morning, Boat Trip 9:30-3:00

Wednesday Evening 4:00-7:20

Session 5 Theory of Partitioning and Characterization of Phase Behavior

Alan Hatton, session chair

4:00 (#55) N. L. Abbott, "On the partitioning of soluble molecules in two-phase aqueous polymer systems"

4:20 (#56) D. E. Brooks, "Electrostatic and electrokinetic effects in two polymer aqueous phase systems: What's happening?"

4:40 (#57) D. Forciniti, P. Kenhare, C.K. Hall, "Prediction of structure and thermodynamic properties of aqueous two-phase systems using integral equations"

5:00 (#58) H. Cabezas Jr., S.M. Snyder, K.C. Cole, "A theory for the prediction of protein partitioning and phase composition in salt-polymer aqueous two-phase systems"

5:20 (#59) C.A. Haynes, H.W. Blanch, J.M. Prausnitz, "Partitioning of proteins in aqueous two-phase systems: application of low-angle laser-light scattering and membrane osmometry"

5:40-6:00 Coffee Break

Herb Cabezas, session chair

6:00 (#60) H. Hartounian, E. Q. Kaler, S. J. Sandler, "Phase equilibria in aqueous two-phase systems of polymers and salt"

Session 5 (continued)

6:20 (#61) A.D. Diamond, J.T. Hsu, "Analysis of aqueous polymer biphasic systems using modified Flory-Huggins Theory"

6:40 (#62) M. A. Eiteman, J.L. Gainer, "Peptide hydrophobicity and partitioning in poly(ethylene glycol)-salt aqueous two-phase systems"

7:00 (#63) B. Zaslavsky, "General characteristic of partition ability of aqueous polymer two phase systems"

Thursday Morning Continental Breakfast 7:15 (outside meeting room)

8:00-10:05 Session 6 Gravitational Effects of Separation Related Processes

8:00 Introduction, Laurel Karr, session chair

8:05 (#64) J.M. Van Alstine, J.M. Harris, L.J. Karr, S.B. Bamberger, "Phase demixing in microgravity"

8:25 (#65) P. Concus, R. Finn, "Effect of container geometry on fluid configurations in zero gravity"

8:45 (#66) D. Ramkrishna, R. Muralidhar, T. Tobin, H. Wright, "Analysis of transport in dispersed phase systems. An inverse problem methodology"

9:05 (#67) M. Weislogel, "Capillary surface reorientation during brief periods of reduced gravity: Effects of surface coatings"

9:25 (#68) P. Todd, R.M. Stewart, S.R. Rudge, H. Cabezas, "Electrolyte transport in charge-dependent two-polymer systems: Application of the low-gravity environment"

9:45 (#69) I. A. Sutherland, " Bioprocessing Space Technology"

10:05-10:40 Poster Session 4 and Coffee Break

(#70) J.A. Asenjo, B.A. Andrews, F. Hashim, T. Franco, "A model for predicting the partition behaviour of proteins in aqueous two-phase systems"

(#71) J.C. Baygents, J.M. Van Alstine, D.A. Saville, "Electrokinetic characterization of aqueous two-phase emulsion droplets"

(#72) Y. Guan, T.E. Treffry, T.H. Lilley, "A theoretical analysis of aqueous two-phase partition systems"

Poster Session 4 (continued)

(#73) D. Hawker, R. Davis, P. Todd, R. Lawson, "Effects of fluid and thermodynamic factors on biological and latex particle partitioning"

(#74) M.S. Deuser, J.M. Van Alstine, J.C. Vellinger, F.C. Wessling, C.A. Lundquist, "Design of multisample, multistep phase partitioning apparatus for use on space shuttle, spacelab, and spacehab missions"

(#75) L. Piculell, L. Falck, S. Nilsson, F. Tjerneld, K. Bergfeldt, "Phase separation in aqueous mixtures of similarly charged polyelectrolytes"

(#76) C. Tilcock, Q.F. Ahkong, D. Fisher, "Effect of surface-attached polyethylene glycol upon lipid polymorphism and vesicle stability in vitro"

Thursday Morning 10:40-12:00

Session 7 Polymer-Protein and Polymer-Surface Interactions

Don Brooks, session chair

10:40 (#77) H. Walter, T.J. Webber, E.J. Krob, "Effects of cell exposure to dextran or poly(ethylene) glycol prior to cell partitioning"

11:00 (#78) T. Franco, A.T. Andrews, J.A. Asenjo, "Use of chemically modified proteins for investigating the effect of charge and hydrophobicity and partitioning in atps"

11:20 (#79) P. A. Harris, G. Johansson, F. Tjerneld, "Interaction in affinity partitioning studied using fluorescence spectroscopy"

11:40 (#80) C. Tilcock, Q.F. Ahkong, S. Koenig, R. Brown III, G. Kabalka, D. Fisher, "Effect of surface-attached polyethylene glycol on lipid mobility and water exchange in unilamellar lipid vesicles: Relevance to the design of liposomal magnetic resonance contrast agents"

12:00-2:00 Lunch

Thursday Afternoon 2:00-5:40

Session 8 Novel and Complementary Techniques

2:00 Introduction - Jim Van Alstine, session chair

2:05 (#81) Y.W. Lee, C.E. Cook, D.C. Chen, P. Ray, Y. Shibusawa, Y. Ito, "Application of high speed countercurrent Chromatography/Aqueous two-phase solvent systems for the purification of recombinant proteins"

2:25 (#82) Y. Shibusawa, Y. Ito, Y.W. Lee, "Countercurrent chromatography of proteins with polymer phase systems using cross-axis synchronous coil planet centrifuge"

2:45 (#83) J. T. Hsu, F.E. Chou, "Protein separation using aqueous two-phase systems in the eccentric multi-layer coil planet centrifuge"

3:05 (#84) D. J. Morr , "Isolation of endosomes and endosomal subpopulations by sequential aqueous two phase partitioning and preparative free flow electrophoresis"

3:35 (#85) B.D. Kelley, D.I.C. Wang, T.A. Hatton, "Affinity-based reversed micellar protein extraction"

4:00-4:30 Poster Session 5 and Coffee Break

(#86) J.G. Huddleston, J.A. Flanagan, A. Lyddiatt, "Aqueous two-phase partition: Practical comparison with competing and complementary technologies in the biochemical recovery of proteins"

(#87) R.J. Cronise, J.M. Van Alstine, "Realtime microscopic visualization of column partitioning"

Oral Presentations Continued (Session 8)

Francis Arnold, session chair

4:30 (#88) J.M. Van Alstine, R.J. Cronise, S.B. Bamberger, "New phase supports for column partitioning"

4:50 (#89) J. Radolf, M.D Norgard, M.V. Norgard, "Characterization of spirochete membrane immunogens using Triton X-114 phase partitioning"

5:20 (#90) R. Heusch, "Isolation and purification of substances with aqueous two-phase systems without addition of salt"

Thursday Evening

5:40 Business Meeting

7:30 Banquet

Friday Morning Continental Breakfast 7:15 (outside meeting room)

Session 8 Continued 8:00-11:20

Novel and Complementary Techniques

Paul Todd, session chair

8:00 (#91) P. Dhal, B. H. Chung, F.H. Arnold, "Advances in metal-affinity separations"

8:30 (#92) R. S. Snyder, P. H. Rhodes, "Electrohydrodynamic Considerations for Electric Field Driven Phase Separation"

8:50 (#93) C. Bull, A. Gross, J.F. Walter, "A tale of two systems: Methods for aspartame synthesis in organic media"

9:20 (#94) W.M. Clark, C.W. Theos, M.A. Marando, "Protein separations with two-phase electrophoresis"

9:50-10:10 Coffee Break

Robert Snyder, session chair

10:10 (#95) M. Levine, H. Cabezas, M. Bier, "Electrophoresis of solutes in aqueous two-phase systems"

10:40 (#96) P. Todd, R.M. Stewart, K.S.M.S. Raghava Rao, S.R. Rudge, "Electrokinetic demixing of two-polymer systems: role of dissolved phosphate ions"

11:00 (#97) N.L. Burns, J.A. Riggs, J.M. Harris, J.M. Van Alstine, "Electrokinetic characterization of polymer coatings for control of phase wall wetting and other surface phenomena"

ABSTRACTS

IMMOBILIZED METAL ION AFFINITY PARTITIONING (IMAP) OF PROTEINS AND CELLS

G. Birkenmeier¹, A. Otto¹, B. Sulk¹, G. Kopperschläger¹,
H. Goubran Botros², M.A. Vijayalakshmi²,
T. Stigbrand³ and P.E. Jensen³

¹Institute of Biochemistry, University of Leipzig,
Liebigstr. 16, O-7010 Leipzig, Federal Republic of Germany

²Universite de Technologie de Compiègne, B.P. 649,
F-60206 Compiègne, France

³Institute of Physiological Chemistry, University of Umeå,
S-90187 Umeå, Sweden

Immobilized metal ions were used for affinity extraction of proteins in aqueous two-phase systems composed of PEG and dextran or PEG and salts. The effect on partitioning of proteins of such chelating PEG derivatives coordinated with different metal ions is demonstrated. The proteins studied were α_2 -macroglobulin, tissue-plasminogen activator, superoxide dismutase, lipases and monoclonal antibodies. It was found that the affinity partitioning effect strongly depends on the nature of the transition metal ions complexed to chelate-PEG. Other parameters exerting significant effects on affinity partition of proteins were studied in detail.

Furthermore, the applicability of immobilized metal ion affinity partition for separation of cells using erythrocytes as model is presented. It was found that copper-chelate-PEG was effective in affinity extraction of human and rabbit erythrocytes, while zinc-chelate-PEG displayed significant affinity only to the rabbit cells. The interference of various effectors on affinity partitioning of erythrocytes was examined.

The results indicate that immobilized metal ion affinity partitioning provides the potential for extractive purification of proteins as well as for cell separation.

Tryptophan-rich peptide handles to increase the partition coefficient of proteins in PEG/potassium phosphate aqueous two-phase systems

Kristina Köhler¹, Charlotta Ljungquist¹, Akihiko Kondo², Björn Nilsson³ and Andres Veide¹

¹Department of Biochemistry and Biotechnology, Royal Institute of Technology, S-100 44 Stockholm, Sweden

²Department of Applied Chemistry, Kyushu Institute of Technology, Sensuicho, Tobata, Kitakyushu 804, Japan

³Department of Biochemistry, KabiGen AB, S-112 87 Stockholm, Sweden

A novel method to partition recombinant proteins into the PEG-rich top phase in poly(ethylene glycol) (PEG)/potassium phosphate aqueous two-phase systems will be presented. The concept is based on fusion of a gene fragment encoding a short peptide sequence, AlaTrpTrpPro, to the product gene of interest to change its partitioning properties. The interest in tryptophan originates from partitioning of *Escherichia coli* β -galactosidase, which is known to be rich in tryptophan residues compared to other proteins from the same species, and from the special partitioning behaviour of tryptophan-containing dipeptides described in literature.

The partitioning of an intracellular model protein produced in *E. coli* containing zero, one or three peptide sequences (T0, T1 and T3), respectively, have been studied. Large effects on the partition coefficients were found for the model proteins containing T1 and T3 compared to the corresponding protein lacking the peptide.

To further investigate possible specific interactions between PEG and tryptophan, we are using chromatography on a PEG-column and an aliphatic carbon chain-column, both with potassium phosphate gradient elution. To distinguish between hydrophobic and specific interactions (eg. Trp and PEG) we are studying a possible relationship between chromatographic behaviour and accessible surface area of the proteins.

PARTITIONING OF PROTEINS IN DETERGENT-BASED AQUEOUS TWO-PHASE SYSTEMS

Georg C. Terstappen and Maria-Regina Kula

Institut für Enzymtechnologie der Heinrich-Heine-Universität
Düsseldorf, Forschungszentrum Jülich, P.O. Box 20 50, D-5170
Jülich, FRG

Abstract

Nonionic detergents of the polyoxyethylene-type exhibit an inverse temperature coefficient, i.e. raising the temperature leads to a decrease in solubility. At a specified temperature, called the cloud point, the solution becomes turbid and separates into two phases upon standing at a somewhat higher temperature. The so-called coacervate phase is rich in detergent, whereas the other phase is detergent-depleted.

The partitioning behaviour of model proteins like lipases, proteases and BSA in such detergent-based aqueous two-phase systems has been studied with special emphasis on the relationship between detergent structure and protein uptake into the coacervate phase. Using a range of different polyoxyethylene detergents, a strong correlation between increasing detergent alkyl chain-length and protein partitioning into the coacervate phase has been found, whereas the ethylene oxide moiety had no significant effect.

Increasing the hydrophobicity of the corresponding detergents by increasing the alkyl chain-length - as shown via their retention behaviour on a reversed-phase HPLC column - also led to an increase of the relative amount of detergent present in the coacervate phase. The absolute values for protein recovery and partition coefficients K could be correlated with the measured "effective hydrophobicity" of the respective proteins, thus confirming the hydrophobic nature of this partitioning process.

Moreover, the influence of temperature, pH and different additives on the partitioning behaviour has been investigated using selected proteins and detergent systems.

Finally, attempts have been made to apply such an extraction system for the isolation of lipases from fermentation broth.

A Novel Method for Purification of Plastocyanin

Per-Ake Albertsson and Agneta Persson

Department of Biochemistry, Chemical Center,
University of LUND, S-222 00 LUND, Sweden

Plastocyanin is a blue copper protein which catalyses electron transport from cytochrome f to P700 in the photosynthesis of plants and green algae. It resides in the lumen, that is on the inner side, of the thylakoid membrane. We have made use of this localization of plastocyanin for its purification by a combination of partition and chromatography. Thylakoids are sonicated in 10 mM Na phosphate pH 6,4, 200 mM NaCl and then partitioned in a two-phase system of 1% (w/w) Dextran 500 and 8% (w/w) PEG 3350 with 160 mM NaCl and 8 mM Na phosphate, final concentration, pH 6,4. The membrane fragments partition exclusively into the small bottom phase (10% of the total volume) while most of the plastocyanin is recovered in the upper phase. This is collected after centrifugation at 10,000 rpm 3 min and diluted to twice its volume and applied to an ion exchange column (DEAE-sepharose) for further purification and concentration.

Starch synthesizing enzymes, isolated and studied by phase partitioning.

Andreas Blennow and Göte Johansson
Department of Biochemistry, Chemical Center,
University of Lund, P.O. Box 124,
S-221 00 Lund, Sweden.

An Aquaphase PPT / poly (ethylene glycol) aqueous two-phase system was used to isolate the soluble starch synthase and the Q-enzyme (branching enzyme) from a raw homogenate of potato tubers. The partition coefficient for the starch synthase was 0.13, while the bulk protein was evenly distributed. By using this kind of "affinity partitioning" step in a purification procedure, in combination with ammonium sulfate precipitation and hydroxyapatite adsorption, the starch synthase, Q-enzyme and debranching enzyme were purified 390, 77 and 58 times, with 16, 3.1 and 2.3 % recovery, respectively. The partition coefficient for purified starch synthase, in an Aquaphase PPT / poly (ethylene glycol), was increased nine-fold by addition of the triazine dye Procion yellow HE-3G bound to Ficoll-400. Interaction between the starch synthase and the Q-enzyme was studied by performing counter-current distribution, using a Ficoll / poly (ethylene glycol) system. The two enzymes interacted with each other under low salt conditions, while no interaction was detected in the presence of 50 mM potassium thiocyanate or 100 mM sodium citrate.

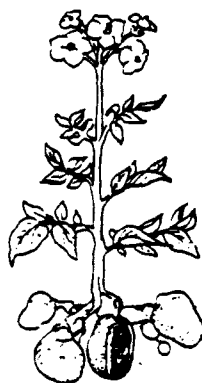

Isolation and Purification of Penicillin G Acylase from Disrupted
E. coli by Two Phase Method

Chiu-Hsing Lin and Min-Huey Lin

Union Chemical Laboratories, Industrial Technology Research Institute
321 Kuang Fu Road, Section 2, Hsinchu, Taiwan 30042, Republic of China
Fax : 886-35-716945

Abstract

An efficient method for isolating penicillin G acylase from disrupted E. coli cell suspension has been developed. The addition of polyethylene glycol (PEG) and potassium phosphate (phosphate) into the cell suspension separates cell debris and recovers intracellular enzyme.

1. When PEG 600 and phosphate were added, penicillin G acylase appeared in top phase with partition coefficients larger than 20 and 110% recovery.

2. When PEG 4,000 and phosphate were added, penicillin G acylase appeared in bottom phase with rather small partition coefficients, 0.02-0.05, and 95% recovery.

Therefore, alternative uses of the partition systems may greatly facilitate the isolation and purification of penicillin G acylase from the fermentation broth.

PARTITIONING AND PURIFICATION OF MONOCLONAL ANTIBODIES IN AQUEOUS TWO-PHASE SYSTEMS

S. Nielsen and J.A. Asenjo

Biochemical Engineering Laboratory
University of Reading
P.O. Box 226, Reading RG6 2AP, England

The partition behaviour of pure IgG in aqueous two-phase systems has been examined in order to investigate the effect of changes in phase composition on the partition coefficient, K . Factors such as molecular weight of PEG, pH and concentration of NaCl and other salts were all found to influence K . Optimal conditions were found using a factorial design due to the high level of interactions between the phase components. Using this methodology it was possible to find conditions which gave extremely high values of K for the IgGs (>100). Partition behaviour of main potential contaminants such as BSA and transferrin were also studied. All the components were characterized for hydrophobicity, pI and M.W. This was carried out by Hydrophobic Interaction Chromatography (HIC) using an FPLC (Phenyl Sepharose - Fast Flow), Isoelectric Focusing (IEF) and SDS-PAGE. Conditions were chosen under which the partition coefficient of the contaminants was low (pH 6, 15% PEG 2000, 14% Phosphate and 12% NaCl). Precipitation of IgG was also minimized. These conditions were chosen for the extraction of IgG from the contaminants in a crude concentrated supernatant. The value of the separation factor will depend both on the concentration of contaminant proteins which is directly related to media design as well as on the volume ratio for the lighter to heavier phases chosen (1/1, 1/6, 1/10). The presence of culture media contaminants had a rather strong effect on the partition of IgG which was much lower than for pure IgG ($K > 10$). The ratio of $K_{\text{IgG}}/K_{\text{cont}}$ was >25 . Analysis by HIC showed that virtually all IgG partitioned to the top phase and the contaminants to the bottom phase. This was confirmed by SDS-PAGE analysis. Optimal conditions for the recovery of the IgGs in a bottom salt phase for the 'back extraction' were also found.

A serum free crude concentrated culture supernatant with a relatively low level of protein contaminants (15% IgG purity) was processed in this system. After the back extraction the contaminants were reduced 18 fold giving an IgG with a 79 % purity. A 5.3 fold purification was obtained out of a 6.7 maximum possible (at 100% pure IgG). If a starting material with a higher level of contaminants is used much higher purification can be obtained. The overall yield was 80%.

PARTITIONING DETECTS DIFFERENCES IN THE RELEASED FORMS OF ALKALINE PHOSPHATASE (ALP), A GPI-ANCHORED PROTEIN

F.D. Raymond¹, D. Moss¹ and D. Fisher²

¹ Department of Chemical Pathology, Royal Postgraduate Medical School, Hammersmith Hospital, LONDON W12 0NN and ² Biochemistry Department and Molecular Cell Pathology Laboratory, Royal Free Hospital School of Medicine, LONDON NW3 2PF, UK.

INTRODUCTION

In recent years a novel mechanism by which proteins are anchored to membranes has been elucidated. This involves a covalent linkage from the protein to an oligosaccharide which in turn is linked glycosidically to phosphoinositol, embedded in the outer monolayer of the membrane bimolecular leaflet [1,2]. This class of molecules are called glycosyl-phosphatidylinositols (GPIs) (Fig 1). A number of diverse membrane proteins have been identified to have GPI anchors, including alkaline phosphatase, 5-nucleotidase, decay accelerating factor, and T.Brucei variant surface glycoprotein (VSG). The membrane protein can be cleaved from membrane surfaces by treatment with phosphoinositol specific phospholipase D (PIPLD) or phosphoinositol specific phospholipase C (PIPLC) (see Fig 1). PIPLD has recently been isolated from human serum [3]. For studies on the possible role of this enzyme in the release of GPI anchored proteins in normal and disease states a partitioning assay for PIPLD has been developed.

RESULTS AND DISCUSSION

Alkaline phosphatase (ALP) from an osteogenic/osteosarcoma cells line (SOAS) was released by treatment with PIPLD, PIPLC, bromelain, and human serum, and then partitioned in three non charge sensitive phase systems of Dextran T500 (D) and PEG 6000 (P), prepared in 0.15M NaCl buffered with 0.01N sodium phosphate pH 6.8:- (1) 5%D:4.2%P; (2) 5%D:4.5%P; (3) 5%D:5%P. Alkaline phosphatase released by PIPLD showed high bottom phase partition, closely similar to that obtained with serum released ALP, whilst ALP released by PIPLC had a markedly different partition, favouring the top phase. Partitioning is thus able to distinguish between molecular forms of ALP which differ by a single phosphate group. This difference may be related to changes in protein conformation as a consequence of the phosphate group. Interestingly ALP released by bromelain had a similar partition to the PIPLC released material, although the bromelain site of action is at some distance from that of PIPLC or PIPLD.

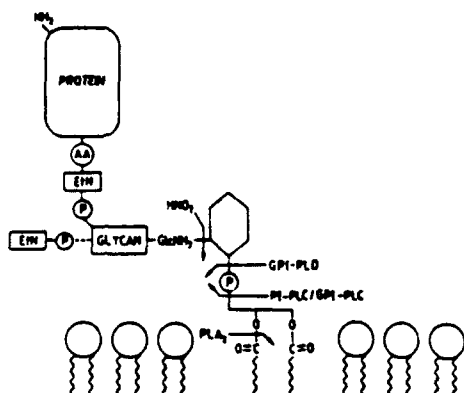

Fig 1 Structural features of GPI anchor molecules

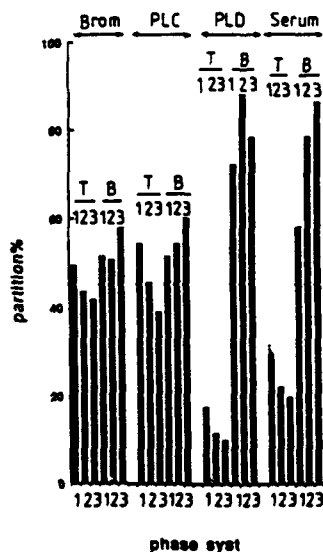

Fig 2 Partition of ALP in top (T) and bottom (B) phase Systems: (1) 5%D:4.2%P; (2) 5%D:4.5%P; (3) 5%D:5%P

CONCLUSION

Phase partitioning can be used to assay PIPLD and distinguish it from PIPLC activity.

REFERENCES

- 1 Ferguson, M.A.J. and Williams, A.F. (1988) Ann.Rev. Biochem. 57,285-320
- 2 Low, M.G. and Saltiel, A.R. (1988) Science 239, 268-275
- 3 Raymond, F.D and Moss, D. Biochim. Biophys. Acta in press

EXTRACTION OF INTERFERON- γ USING PEG / K_3PO_4 AQUEOUS TWO-PHASE SYSTEM

Zhong-yao shen, Mei Cong, Ji-chu Yang
(Department of Chemical Engineering, Tsinghua University,
Beijing, China)

ABSTRACT

Interferon- γ (γ -IFN) is an important immuno regulatory lymphokine, which has great clinical values, such as inhibiting the cancer cells and viruses. The separation and purification of γ -IFN is a difficult and crucial problem awaiting a solution urgently. Aqueous two-phase system extraction as an effective separation technique has a lot of advantages in the application of biotechnology. In this paper, the aqueous two-phase system of polyethylene glycol (PEG) / potassium phosphate (K_3PO_4) is selected to extract the γ -IFN from the broth of splitting E. Coli cells, which were recombinated genetically and were fermented in high expressivity. The effects of the concentrations of PEG and phosphate, and of the pH values on the partition behaviour of γ -IFN and other contaminating proteins have been investigated. The results showed that the pH value is the most powerful factor for the extraction yield of γ -IFN. Based on the experimental data, an optimal extraction condition was searched out: PEG 4000 20% / K_3PO_4 14%, pH = 11. In this case, the γ -IFN could be extracted to the PEG-rich phase (top phase), $K_r = 70$, and most of the other proteins were remained in the salt-rich phase (bottom phase), $K_p = 0.9$. So that the extraction yield of 98% and primary purification of γ -IFN were achieved. It is proved that the ELISA is a feasible assay method for analyse the γ -IFN quantitatively in this study. It has the advantages of high sensitivity, short analytical time and convenient operation.

Optimization of the extraction of C₄-phospho(*enol*)pyruvate carboxylase, using aqueous two-phase systems.

Silva, A.B.#, Pissarra, P.N.*, Arrabaça, M.C.#

* King's College, University of London, # Departamento de Biologia Vegetal, Faculdade de Ciências, Universidade de Lisboa

Phospho(*enol*)pyruvate carboxylase (E.C.4.1.1.31) is the enzyme responsible for the fixation of atmospheric CO₂ in C₄ plants. The enzyme extracted from leaves is usually very unstable and undergoes a quick inactivation process. One way of overcoming such problems is to use extraction methods capable of preserving PEPC namely adding a protective agent like PEG.

PEPC was extracted from a C₄ plant (*Paspalum dilatatum*) using a 10% (w/v) PEG₄₀₀₀/3.3% (w/v) dextran T-500 system, with potassium phosphate 0.2 M. The effect of biomass concentration on the enzyme partition was studied and it was observed that 0.18 g of biomass fresh weight (FW) per ml of extraction medium was the optimum value for a maximum of PEPC activity. Higher values did not show an increase in the total activity instead the curve reached a "plateau" level. The yield of partition was always very high (95-100%). In the crude extract the best value of biomass concentration for enzyme extraction was around 10 fold lower.

The effect of pH was studied using potassium phosphate (pH values between 7-8) in the extraction medium and in the aqueous phase system. The determination of enzymatic activity was always carried out at a pH value of 8.0. The results obtained showed a strong effect of pH, 7.3 being the most adequate value for enzyme extraction.

PEPC stability was higher ($t_{1/2}=17.1$ h) when the enzyme was extracted and preserved in the PEG-top phase than in the crude extract which initial activity was insignificant.

This study has demonstrated that aqueous two-phase systems can be successfully used for PEPC extraction. They allowed the recovery of more active enzyme and increased significantly its stability.

Ionic Strength Dependence of the Solubility in Aqueous Two-Phase Systems and Polyethylene Glycol Solutions of Lipoxygenase in Crude Mixtures and in Purified Form.

Steven M. Snyder and Kenneth D. Cole

National Institute of Standards and Technology
M.S. 831.01
325 Broadway
Boulder, CO 80303

Lipoxygenases are a family of enzymes that transform polyunsaturated fatty acids to hydroperoxides using molecular oxygen. Lipoxygenase is present in soybeans and other plant material. Soybean lipoxygenase has a molecular mass of approximately 100,000 and is present in four forms with differing kinetic and substrate properties. We have used extraction systems composed of polyethylene glycol (PEG) and salt to separate crude extracts from soybeans. Lipoxygenase was measured by using enzymatic activity and analytical gel electrophoresis. Greater than 90% of the total activity was present in the top phase (PEG-rich). The storage proteins and majority of the other proteins were present in the bottom phase (salt-rich). Lipoxygenase displays unusual solubility in PEG solutions when significant amounts of salt are present. Lipoxygenase from crude extracts of lipoxygenase was soluble in 40% 1000 PEG in the presence of 0.5 M NaCl. The solubility of lipoxygenase appears to correlate with the amount of salt present in the PEG solution. It is known that associations between different proteins (hetero-association) and self association can have a significant effect on their solubility in PEG. We are using crude extracts and purified lipoxygenase to determine the extent of these associations on the partitioning and solubility of lipoxygenase.

PROTEIN SEPARATION USING AQUEOUS TWO-PHASE PARTITIONING

M. Hossein Hariri, Rose-Hulman Institute of Technology
G. Ali Mansoori, University of Illinois at Chicago
and Paul Todd, Nat. Institute of Standards and Technology

ABSTRACT

Use of Aqueous Two-Phase Partitioning (ATPP) (see Figure 1) in extraction of biologically active proteins from biological fluids is shown to be efficient with high yields and recovery of 90 to 100%. Unlike chromatography, electrophoresis, filtration, and differential centrifugation, ATPP is generally considered easily scaleable. Nevertheless, several obstacles have prevented its successful application beyond the bench scale. These include cost, engineering requirements, separation rate, and lack of a predictive paradigm. Engineering requirements must be built on the technical solutions that have been imposed by these obstacles. Thus, the most rapid gains to be made, and the most acute needs in ATPP applications are the establishment of engineering requirements.

For efficient large-scale separation, partition ratio of a component to be separated, which is defined as the product of partition coefficient of that component between two polymer phases and the ratio of the volumes of polymer phases, must have a suitable value. The best separation occurs when the product of partition ratios of two components to be separated from each other is one. Another vital parameter is the time required for phase separation, which in turn depends on phase viscosities and densities.

Macromolecules and other biological substances with differing partition coefficients can be separated either in a single-stage (batch or continuous) or multistage apparatus. For industrial-scale partitioning, multistage separations rely on a liquid-liquid partitioning column. In the proposed arrangement (Figure 2), a pump feeds a heavy polymer phase into the top of the column and a lighter phase into the bottom of the column. These immiscible phases move in opposite directions through alternating mixing and separation stages. The mixing stages effect mass transfer; settling stages allow for phase separation. To perform a separation, the operator introduces a sample in one of two ways: either by feeding it along with one of the two polymer phases, or by injecting it directly into one of the mixing or settling stages.

A phase equilibrium model to predict phase diagram of polymer solutions has been proposed in order to assist us in the design of our separator and contactor. In this model, equations for monodisperse polymers have been modified and extended to polydisperse polymer aqueous solutions and the corresponding equations for chemical potentials using the molecular weight distribution functions of the two polymers have been obtained.

PARTITIONING OF STREPTOKINASE IN AQUEOUS TWO-PHASE SYSTEMS -
APPLICATION TO THE PURIFICATION OF THE PROTEIN

G. Kopperschläger, A. Otto and G. Lorenz
Institute of Biochemistry, The University of Leipzig,
D-7010 Leipzig, Liebigstrasse 16, Germany.

Streptokinase is produced in certain strains of β -hemolytic streptococci and is secreted into the culture medium. It is a monomeric protein (mol. wt. 47 000) and is well characterized by protein chemistry, such as sequencing and conformational properties.

Streptokinase functions through its ability to activate the mammalian plasma proenzyme, plasminogen, to the fibrinolytic enzyme plasmin. Therefore, this protein is widely used as an intravenous drug for the therapy of thrombotic disorders.

Streptokinase purification starts from culture medium after removal of the bacteria by precipitation, absorption and/or ultrafiltration in order to enrich the protein for subsequent steps.

This contribution deals with the application of aqueous two-phase systems for concentrating and purification of streptokinase.

Diverse PEG/dextran systems were generated by varying the molecular weight of the polymers, the concentration of the polymers, the pH of the buffer and salt addition. The partition coefficient, K , of streptokinase altered between 1 to 5. Under the same conditions the K -value of the protein bulk was found to be maximal 2.

Streptokinase favours the PEG-rich phase in PEG/salt systems yielding a maximum partition coefficient of 50. Its partition is independent of the amount applied in the range of 200 units to 2×10^6 units.

A number of systems have been screened in order to determine optimum conditions for the enrichment of the protein from the culture medium. Based on these results a large-scale procedure for the purification of streptokinase has been developed utilizing aqueous two-phase partitioning systems as an initial step.

Göte Johansson, Monica Joelsson and Liling Cheng
Department of Biochemistry, University of Lund, Lund, Sweden

The partition of a protein in aqueous two-phase systems can be adjusted in a more or less specific way by influencing the interactions between the protein surface and the phases. Electrostatic interactions, hydrophobic and affinity ligand binding have been used for this purpose. The electrostatic effects used originate from included salt or charges on one of the polymers. A number of combinations of the thus far utilized ways of partition steering are possible. The partition of polyelectrolytes, e.g. DEAE-dextran, can be strongly affected by the choice of salt and this effect can be used to direct the partition of proteins. Polyelectrolytes can also be combined with polymer bound affinity ligands, either attached to the polyelectrolyte or to another polymer. Some of these possibilities have been tested by partitioning of glucose-6-phosphate dehydrogenase in a dextran - PEG system.

Referance:

L. Cheng, M. Joelsson and G. Johansson (1990) J. Chromatogr. 523, 119-130.

Enhanced Partitioning in Aqueous Two-Phase Systems Using Genetically Engineered β -Galactosidase

John Luther (presenter), Dept. of Chem. Eng., 231 Sweeney Hall,
Iowa State Univ., Ames, Iowa 50011-2230.
Dr. Charles E. Glatz, Dept. of Chem. Eng., 231 Sweeney Hall,
Iowa State Univ., Ames, Iowa 50011-2230.

We are using β -galactosidase (β -gal) as a model system to study improvements in the selectivity of aqueous two-phase extraction through the use of genetic engineering. Previously constructed β -gal fusion proteins containing poly-aspartic acid (negative) or poly-arginine (positive) tails of various lengths were expressed in *Escherichia coli* and purified by affinity chromatography.

Three different phase systems were employed to examine the effect of the additional charge contributed by the fusion tails on partitioning. These systems consist of PEG-4000/Dex-40/Phosphate, PEG-8000/Dex-500/DEAE-Dex/Phosphate/NaCl, and PEG-8000/Dex-500/DEAE-Dex/Phosphate.

In the first system an electropotential difference between the phases is created using potassium phosphate. The partitioning of wild-type β -gal exhibited the expected variation when the net charge was altered by changing pH. Variation of partitioning due to tail charge or length was not observed, however, the fusions collectively exhibited higher partitioning than wild-type β -gal at the same pH.

In the second system the cationic DEAE-Dextran partitions into the PEG rich top phase and acts as a charge affinity ligand with which the proteins can associate. The partition coefficients for the β -gal fusions were found to be an order of magnitude higher than in the first system. As expected, increased partitioning with increasing negative charge was observed except for the longer aspartate tails, which behaved similarly to the shorter aspartate fusion. Assay limits at the high partitioning observed for these fusions (K-550) may account for this result.

The third system is similar to system two except that the conditions are adjusted such that the DEAE-Dextran partitions to the bottom phase, with the expectation that partitioning of the fusions will be reversed.

Work is in progress to examine the third system and to resolve the unexpected behavior observed in the experiments described above, with the results to be included at the conference in June.

Application of Two Phase Liquid-Liquid Extraction to the Purification of Calf chymosin from *A. awamori*

Kirk Hayenga*, Matt Murphy, Ray Arnold, Jeff Lorch and Henry Heinsohn

Genencor International, Process Development, S. San Francisco, CA

We have cloned the milk-clotting enzyme chymosin from bovine calf into the filamentous fungi *A. awamori*. The enzyme is expressed as a glucoamylase-prochymosin fusion protein. The majority of the enzyme is found in the culture medium as mature chymosin. *A. awamori* was selected as the host organism because of its ability to express large quantities of extra-cellular protein. A drawback of this approach is that the fungus also secretes other enzymes that may have detrimental effects in either cheesemaking or whey by-products. Many of the current industrial enzyme purification techniques are either not cost effective or do not produce an acceptable product. With this in mind we designed a recovery process to recover chymosin that implements two phase liquid-liquid extraction using a PEG 8000/ Na_2SO_4 system which meets the purity and cost objectives. We have seen partition coefficients greater than 100 for chymosin in this system.

In order to try to understand why chymosin partitions with such a high coefficient we have compared the partitioning, chromatographic, and chemical properties of chymosin and some of the other proteinases in the aspartic acid proteinase family.

**PARTITIONING, SEPARATION AND PURIFICATION OF THREE
RECOMBINANT PROTEINS IN AQUEOUS TWO-PHASE SYSTEMS**

B.A. Andrews, S. Nielsen, R. Huang, C. Hodgson and J.A. Asenjo

Biochemical Engineering Laboratory
University of Reading
P.O. Box 226, Reading RG6 2AP, England.

Aqueous two-phase systems are an extremely attractive procedure to separate and purify proteins on a large scale. A crucial issue that has to be resolved for widespread application is the question of selectivity of protein partitioning. The ideal system is one with an extremely high selectivity for the target protein: that is a very high partition coefficient (K) for the target protein and an extremely low partition coefficient for all contaminating proteins. Our present work is directed at establishing a rational basis for manipulating partition coefficients based on physico-chemical properties of the proteins and thus allowing the selection of the most appropriate two-phase systems. This is particularly important for the development of large scale processes for the isolation of novel proteins which are being developed by the biotechnology industry today.

Three proteins are currently being studied in aqueous two-phase systems to increase phase affinity and selectivity and develop large scale purification procedures. These are monoclonal antibodies (IgGs), tissue Plasminogen Activator (tPA, a recombinant thrombolytic agent), and Virus Like Particles (VLPs, cloned in yeast presently being used for the development of an AIDS vaccine).

This paper will describe partition behaviour of the pure proteins and the protein contaminants in crude supernatants using a number of selected aqueous two-phase systems. Selection of optimal conditions both for protein separation and also for recovery in a non-polymer phase has been investigated. In all cases PEG/salt systems gave most favourable results. tPA, which is a very hydrophobic protein, gave extremely high values of K (>100) but recovery was difficult and pH manipulation was necessary to increase the solubility in the phases. With IgG optimal conditions were found using a factorial design due to the high level of interactions between the phase components. More than 95% of the contaminants were eliminated in one stage. For VLPs two separation strategies were developed. One was to separate cell debris in the first stage followed by purification of the VLPs from the soluble proteins, and the other was to separate soluble proteins in the first stage and the debris in the second. In all cases high purification factors (>10) could be obtained. Implications for protein recovery, phase recycle and bioprocess development will be presented and discussed in this paper.

ENZYME PURIFICATION USING TEMPERATURE INDUCED PHASE FORMATION

Patricia Alred Harris¹, Gunnar Karlström² and Folke Tjerneld¹

1) Department of Biochemistry and 2) Department of Theoretical Chemistry, Chemical Center, University of Lund, P.O. Box 124, S-221 00 Lund, Sweden.

UCON 50-HB-5100 is a linear nonionic random co-polymer composed of 50% ethylene oxide and 50% propylene oxide with an average molecular weight of 4000. It has many properties similar to poly(ethylene glycol), including temperature induced phase formation in water. However, the cloud point for a 10% solution of UCON 50-HB-5100 is only 55°C, well below the cloud point of 112°C for a 10% solution of poly(ethylene glycol), MW = 20,000. The cloud point of the UCON solution can be lowered to 37°C by the addition of sodium sulfate salt to a concentration of 0.2M. This study investigates the use of UCON instead of poly(ethylene glycol) in aqueous two-phase systems. In UCON/dextran and UCON/hydroxypropyl starch (HPS) systems the UCON polymer is enriched in the top phase and the carbohydrate polymers in the bottom phase. Both phases contain 80 - 95% water. This is comparable with the PEG/dextran systems which are used for separation of macromolecules, membranes, cell particles and cells.

3-Phosphoglycerate kinase and hexokinase from bakers' yeast were purified in aqueous two-phase systems composed of either UCON/dextran or UCON/HPS. Yeast homogenate was first partitioned in a system composed of a top phase containing UCON 50-HB-5100 and a bottom phase containing either dextran or hydroxypropyl starch. The top phase containing the enzyme free of cell debris was removed and the temperature increased until a two phase system composed of water as the top phase and UCON 50-HB-5100 as the bottom phase was formed. The water phase containing the enzyme was removed and the bottom phase containing the UCON 50-HB-5100 could be recycled to perform a second extraction.

The use of polymers which phase separate at increased temperatures offers a rapid and simple method for removing the target enzyme or other macromolecule from the polymer solution once it has been purified in an aqueous two-phase system. The target enzyme can be recovered in water, and the polymer can be recycled.

THE EVALUATION OF DETERGENT-BASED AQUEOUS TWO-PHASE SYSTEMS FOR THE LARGE-SCALE PURIFICATION OF PROTEINS

R. Andrew Ramelmeier and Maria-Regina Kula

Institut für Enzymtechnologie der Heinrich-Heine-Universität
Düsseldorf, Forschungszentrum Jülich, P.O. Box 2050, D-5170
Jülich, FRG

Abstract

Aqueous solutions of nonionic polyoxyethylene detergents generally exhibit a cloud point at a certain temperature, above which two phases are formed; one phase is rich in detergent, while the other contains very little detergent. Proteins have been observed to partition selectively between the two phases depending on protein hydrophobicity.^{1,2} To date, however, this extraction method has been conducted exclusively on a laboratory-scale and the partitioning measured only qualitatively.

Cholesterol oxidase from various bacterial sources (membrane-bound and extracellular) was studied in Triton X-114^R solutions as a model system to characterize protein partitioning and to evaluate the potential for scale-up. Under optimal conditions of temperature and salt concentration, the enzymes exhibited remarkable recovery (over 70% and 90% in the detergent-rich phase for the extracellular and membrane-bound forms, respectively) and 10 to 20-fold concentration in just one purification step.

From preliminary small-scale experiments the rate of phase formation and protein mass transfer has been observed to occur very rapidly. Physicochemical properties of the two phase system (notably viscosity, density difference and interfacial tension) have been measured to determine if any processing constraints of the phases exist.

Finally, Triton X114-based extraction has been applied to the isolation of the cholesterol oxidase (the membrane-bound and extracellular forms) from cultivated cells on small and large scales. The technique appears to be ideally suited for the initial-stage purification of relatively hydrophobic proteins, which are either associated with the cell-membrane or excreted into solution.

¹ Bordier, C. (1981) J. Biol. Chem. 25, 1604-1607

² Pryde, J.G. (1986) TIBS 11, April Ed., 160-163

Aqueous two-phase extraction for the recovery of peptide hormones

Kristina Köhler¹, Björn Nilsson² and Andres Veide¹

¹Department of Biochemistry and Biotechnology, Royal Institute of Technology, S-100 44 Stockholm, Sweden

²Department of Biochemistry, KabiGen AB, S-112 87 Stockholm, Sweden

The usefulness of aqueous two-phase extraction as a primary recovery step on downstream processing of peptide hormones (IGF-I and IGF-II) produced by bacteria will be discussed. Application of the technique, using phase systems based on poly(ethylene glycol) (PEG) and potassium phosphate, on target proteins located either extra- or intracellularly in *Escherichia coli* will be covered.

In the extracellular case, the phase components in solid form are added into the fermenter to form the phase system. Separation is obtained by centrifugation. The product is collected in the PEG-rich top phase, while the cells are displaced to the salt-rich bottom phase.

Use of protein engineering to selectively increase the distribution of the target protein to the PEG top phase will be exemplified. This can be achieved by fusing a DNA sequence coding for a peptide, which is rich in tryptophan, to the sequence coding for the target protein.

Studies on the Isolation of Penicillin Acylase from *Escherichia coli* by Aqueous Two-Phase Partitioning

Y. Guan^{**}, X. Wu⁺, T.E. Treffry, T.H. Lilley^{**}

⁺Department of Biochemical Engineering, East China University of Chemical Technology.

^{*}Department of Molecular Biology and Biotechnology and

^{**}Department of Chemistry, University of Sheffield.

The method investigated for the separation of penicillin acylase (PA, penicillin aminohydrolase, EC 3.5.1.11), involves enzyme release and aqueous two-phase extraction. A 20% (w/v) *E. coli* suspension is agitated with 12% butyl acetate for 3 hours at 37°C. The release of PA from freeze-thawed cells was 70%.

The treated *E. coli* suspension was then subjected to aqueous two-phase extraction systems. Polyethylene glycol (PEG)-phosphate system was chosen for its low cost. For a simple PEG-phosphate system the partition coefficients of the enzyme are rather low, usually in the range of 2-5. A PEG derivative two-phase system, therefore, was resorted to by covalently binding of some end groups, including ampicillin, aniline, phosphate and trimethylamine, to PEG molecules.

We have noted that pH has completely different effects on PA partition in phosphate-bound and trimethylamine-bound PEG-phosphate aqueous two-phase systems, as shown in Fig.1. It is evident that, if proteins and phase-forming polymers have different net charges, the polymer-rich phase will attract the proteins. Fractionation of various proteins can be achieved through selective extraction based on their different isoelectric points by adjusting the pH of the system. This assumes that interaction among protein molecules is weak, but accurate control of pH is required. PA yields in the upper phase for PEG-aniline and PEG-N⁺(CH₃)₃ system are the highest, see Fig.2, but it is difficult to recover PA from PEG-aniline because of its specific interaction. This mitigates against the further purification of the enzyme and recovery of phase-forming polymers. PEG bound by trimethylamine is the most successful. A system containing 12% (w/w) PEG 4000 in which 5% (w/w) PEG-N⁺(CH₃)₃ was included with 0.7M potassium phosphate and pH 7.2, resulted in partition coefficient greater than 35 with 98% recovery on a litre scale.

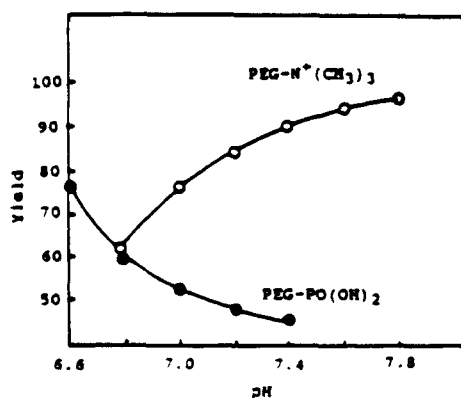

Fig.1 Effect of pH on enzyme yield in PEG-derivative/phosphate systems

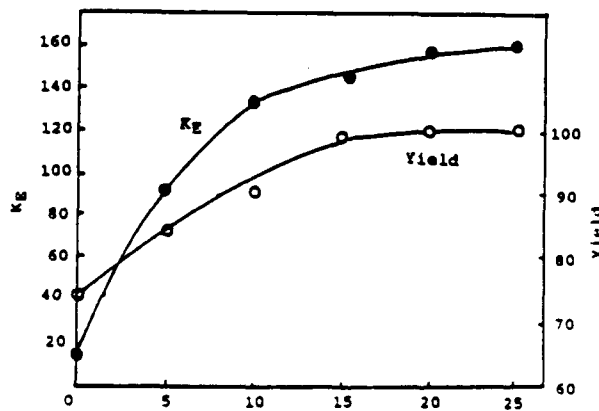

Fig.2 Partition of penicillin acylase in a PEG/phosphate system with PEG-aniline. 12% PEG4000, 0.6M K₂PO₄ pH7.1, cell mass 5g

A POLYETHYLENE GLYCOL-SODIUM CHLORIDE MULTIPHASE SYSTEM FOR
EXTRACTION OF ACID HYDROLYSATES

R. Stewart and P. Todd

Biophysical Measurement Group, National Institute of Standards and
Technology, Boulder, Colorado 80303

Polyethylene glycol (PEG) and sodium chloride (NaCl) form a multiphasic system at temperatures above 40°C. This system was used for the extraction of peptide flavorings from yeast acid hydrolysates. The phase diagram of the PEG-NaCl system was characterized at 60°C and was found to have a closed envelope containing a liquid/liquid region and a liquid/liquid/solid region. In the extraction of flavorings from yeast acid hydrolysates the cell wall debris partitioned exclusively into the bottom, salt-rich phase, while a significant fraction of the amino acids partitioned into the upper, PEG-rich phase.

**AQUEOUS TWO-PHASE PARTITION AS A METHOD FOR
DETECTING DOWNSTREAM TARGETS OF
DEVELOPMENTALLY-REGULATED TRANSCRIPTION FACTORS**

SEBASTIAN SHIMELD AND PAUL T SHARPE

**Molecular Embryology Laboratory
Department of Cell and Structural Biology
Stopford Building
University of Manchester
Manchester M13 9PT
UK**

Much interest has recently focussed on the role of multigene families of transcription factors in the control of embryonic development. One major group of these genes are those containing homeobox's which in mammals are organised in clusters of 9-11 genes on four major chromosomal locations. Studies of the regulation of homeobox gene expression in embryos have revealed a cascade of gene activity controlling axial specification by cross- and autoregulatory interactions between different homeobox genes and gene products. Little, if any, information is however currently available on the target genes of homeoproteins (other than other homeobox genes!). Based on the presumption that all major developmental processes involve cell surface changes we have devised a strategy for detecting surface changes induced by ectopic homeobox gene expression using aqueous phase partition.

**Design and implementation of a prototype liquid partition process
for the recovery of bulk protein fractions from brewery waste**

Julia A Flanagan, Jonathan G Huddleston and Andrew Lyddiatt

Biochemical Recovery Group, School of Chemical Engineering,
University of Birmingham, Edgbaston, Birmingham B15 2TT UK

Oral Abstract

Beer and lager manufacture generates a continuous supply of spent brewer's yeast which exceeds 70,000 tonnes per annum in the UK. Such material has low inherent value and is variously disposed of as animal feed, agricultural fertiliser, or as feedstock for the manufacture of yeast extracts to supplement human and animal food. The latter are predominantly rich in free amino acids, nucleotides, vitamins and other organic micromolecules generated by the extensive cell autolysis exploited in such processes.

Intact bulk fractions of yeast proteins exhibit useful functional properties (foaming, whipping, gelling etc), and may have a role in food manufacture (1). However, the intracellular location of intact macromolecules and the requirement to eliminate carbohydrate, nucleic acid and proteases in long-life products destined for human consumption, pose severe technical problems in manufacture by conventional routes (2).

An account will be given of the developmental steps associated with the design and implementation of a prototype process for protein production exploiting partition in poly(ethylene glycol)-potassium phosphate systems. Practical advantages associated with ready clarification of extracts of disrupted yeast cells, and the preferential fractionation of protein product from bulk impurities will be outlined. This work derives from an earlier study of protein fractions from baker's yeast (3).

Inadequacies in current assumptions regarding de novo process design in aqueous two-phase systems were highlighted in the work, and necessitated the adoption of an empirical strategy to establish optimum conditions for the two-stage process. Comparative experiments with both yeast extracts and purified preparations of defined protein molecules illustrated the strong influence of phase volume ratio upon primary extraction steps, and the selective influence of added salts and pH manipulation upon the secondary extraction (4). The physical and chemical factors which require practical consideration in the de novo design of a prototype process will be discussed.

1. Lyddiatt et al (1990). In: Proc International Conference on Biotechnology in the Food Industry (ed B Mosely), IBC Technical Services, London.
2. Flanagan (1989). M Sc Examination Thesis, University of Birmingham.
3. Huddleston et al (1991). *Enz Microb Technol* 13, 24.
4. Flanagan et al (1991). *Bioseparation*. In press.

PARTITIONING AND SEPARATION OF tPA (TISSUE PLASMINOGEN
ACTIVATOR) IN AQUEOUS TWO-PHASE SYSTEMS

C. Hodgson, B.A. Andrews, V. Riveros-Moreno* and J.A. Asenjo

Biochemical Engineering Laboratory
University of Reading
P.O. Box 226, Reading RG6 2AP, England

*Welcome Biotech Ltd., Langley Court, Beckenham, England.

The use of aqueous two-phase systems (ATPS) for the separation of tPA (tissue plasminogen activator), a recombinant thrombolytic agent, from contaminant cell culture components, has been studied. The tPA was produced by Chinese Hamster Ovary cells (CHO cells). The partitioning of tPA was investigated as a function of phase forming materials in PEG/phosphate and PEG/Dextran systems. Partitioning was studied in the pH range 3 - 5, NaCl concentrations in the range 0.0 - 1.5M with PEG sizes of 1450 - 8000 M.W.. Dextran M.W. was 500,000.

tPA, which is a very hydrophobic protein, gave extremely high values of the partition coefficient (100 - 1000) but recovery was difficult and pH manipulation was necessary to increase the solubility of tPA in the phases. Best separation was obtained using a PEG 1450/phosphate system and either pH 3 without NaCl or pH 5 with 0.5 M NaCl. tPA recovery in such systems was around 80 - 100% with a purification factor of 7 - 12 fold (with a maximum possible of 19 given the initial concentration of tPA and contaminants) and final purity 90 %. Best results were obtained with a volume ratio of lighter to heavier phase around 1/10. Carrying out such an experiment at a larger scale however resulted in lower recoveries of around 55 - 60% most probably due to the low solubility of tPA. Optimization under conditions of a small ratio of lighter to heavier phases is thus necessary for efficient large scale application. Due to the difficulty of partitioning the tPA back to a more hydrophilic heavier salt phase strategies for tPA recovery from the PEG phase (use of solvents and/or gel filtration) will also be presented and discussed in this paper.

Industrial scale separation of particulate matter including microorganisms in waterbased cutting-fluids using aqueous two-phase systems.

Gunnar Ström¹ and Björn Mälarstig²

¹Pegasus Separation AB, Box 97, S-751 03 Uppsala, Sweden

²Alfa-Laval Industri AB, Box 12086, S-102 23 Stockholm, Sweden

Abstract

Water soluble cutting oils and cutting liquids represent a common type of industrial lubricating agents which are widely used in the engineering industry in connection with cutting, turning, drilling, grinding and similar machining of materials. Their primary function is to increase the useful life of the tools by acting as cooling and lubricating agents between the tools and the work pieces. Cutting fluids consists of so-called base oils, which may be based on mineral oils or synthetic polymers. Rapid microbial growth and build up of the metal fines and other particulate matter often restricts the useful life of the cutting liquids to a few months.

The costs for the acquisition and disposal in Sweden (1977) were estimated to be 140-200 millions SEK, to which should be added the far higher costs for shut-down in connection with the exchange of cutting liquid.

~~A bio-separable cutting fluid based on synthetic polymers have been developed that allows separation of microorganisms and particulate matters from the upper "cutting fluid" - phase to a small lower "collection" phase corresponding to about 0.1 - 0.2 % of the total system.~~

Experiments carried out in the industry using gravimetric separation in 1000 liter tanks, show a substantial reduction of microorganisms and an almost total reduction of inorganic particulate matter even below $1 \mu\text{m}$; from the cutting fluid. In larger systems ($1-30 \text{ m}^3$) a separator can be installed, to speed up the separation.

Quantitative determination of microbial biomass in waterbased coolants by means of aqueous two-phase separation combined with turbidity measurements.

Gunnar Ström¹ and Björn Mälarstig²

¹Pegasus Separation AB, Box 97, S-751 03 Uppsala, Sweden

²Alfa-Laval Industri AB, Box 12086, S-102 23 Stockholm, Sweden

Abstract

Microorganisms e.g., bacteria and fungi, occurring in mineral oil based emulsions or synthetic coolants can cause severe problems in the metalworking industry. In order to control microbial degradation of the products, it is of utmost importance to have rapid test methods to register microbial buildup in huge central systems. A test kit composed of polyoxyalkylene glycol-salt and polypropylene glycol-salt systems have been developed to separate microorganisms from coolant components enabling turbidity quantification. Comparative measurements on a 30 m³ system showed a high degree of correlation between turbidity measurements and traditional direct count measurements using epifluorescence microscopy. The time for analysis is less than five minutes.

APPLICATION OF PHASE PARTITIONING AND THIOPHILIC ADSORPTION
CHROMATOGRAPHY FOR PURIFICATION OF MONOCLONAL ANTIBODIES FROM
CELL CULTURE FLUID

Purification of a murine monoclonal antibody against horseradish

B. Sulk, G. Kopperschläger and G. Birkenmeier
Institute of Biochemistry, University of Leipzig
Liebigstr. 16, 7010-Leipzig, FRG

A two-step method for isolation of a monoclonal antibody against horseradish peroxidase from hybridoma cell culture supernatant is described. Purification was achieved by extraction using aqueous two-phase systems in conjunction with thiophilic adsorption chromatography. In an aqueous two-phase system composed of 5% PEG 1540 and 22% phosphate the monoclonal antibody partitioned in favour of the PEG-rich top phase whereas bulk proteins such as albumin and transferrin were extracted into the salt-rich bottom phase. Final purification of the monoclonal antibody was achieved by subjecting the PEG-rich top phase to thiophilic adsorption chromatography. The monoclonal antibody purified to homogeneity retained its specificity for horseradish peroxidase as verified by polyacrylamide gel electrophoresis and enzyme-linked immunosorbent assay. The potential of this method for large scale purification of monoclonal antibodies is discussed.

The study of Aqueous Two-Phase Partition of Cephalosporin C
from Fermentation Broth

Wei-Song Yin and Wu-Yung Yang

Union Chemical Laboratories, Industrial Technology Research Institute
321 Kuang Fu Road, Section 2, Hsinchu, Taiwan 30042, Republic of China
Fax : 886-35-716945

Abstract

The aqueous two phase system of polyethylene glycol and salts was applied to purify cephalosporin C from filtrated fermentation broth. The purpose of this research is to study the possibility of separating desacetyl cephalosporin C from fermentation broth during cephalosporin C recovery. The partition coefficients of cephalosporin C and desacetyl cephalosporin C were 0.5 and 2.5 respectively. It is a new approach separate desacetyl cephalosporin C from cephalosporin C. The results are much different from our previous experiments of partition of penicillin G ($K > 10$) and lysine ($K < 0.1$) and the details will be furtherly discussed in the presently.

PHASE PARTITIONING OF CEREBROCORTICAL SYNAPTOSOMES

M. J. López-Pérez

Departamento de Bioquímica y Biología Molecular y Celular. Facultad de Veterinaria. Universidad de Zaragoza. SPAIN

Homogenization of brain tissue results in nerve endings shearing from their axonal connections and from surrounding glial elements. The synaptic terminals released can reseal to form "synaptosomes". The synaptosomal fraction presents a unique opportunity to study neuronal and neurotransmitters metabolism and bioenergetics.

Crude synaptosomal preparations are very heterogeneous, containing also free mitochondria, myelin and different vesicles and membrane fragments of different cell origin. In collaboration with C. Larsson we found that mitochondria and synaptosomes from rat forebrain could easily be separated by counter-current distribution in an aqueous two-phase system composed of 6.4% (w/w) Dextran T 500 and 6.4% (w/w) polyethylene glycol (1). The different partition behavior shown by mitochondria and synaptosomes might be mostly due to differences in their surface affinity for the polymer composition of each phase, since their isoelectric points were very similar (4.5 and 4.1, respectively) as determined by cross partition (2).

Since mitochondria and synaptosomes can easily be separated by a batch procedure, we have recently described a rapid (<1h) and simple (no ultracentrifuge is required) method for the purification of rat brain synaptosomes. Nerve terminals prepared by this technique are minimally contaminated and maintain a good metabolic performance (3). This method can be applied for large-scale preparations as might be required for the purification of synaptosomal proteins or nucleic acids. Thus, we have been able to characterize the mitochondrial and synaptosomal poly A-containing RNAs obtained from 80 gr of sheep brain (4).

On the other hand, we have found that drug- or toxin-induced surface modifications of synaptosomes can be experimentally detected by a change in their partition in the system previously described. Thus, β -bungarotoxin specifically induces a change in the partition of a toxin-vulnerable synaptosomal population (5). By this approach, we have estimated that 30-32 % of the total synaptosomal preparation is sensitive to the toxin. This figure was in good agreement with that of 25% obtained by quantitation of the lactate dehydrogenase activity released from toxin-treated synaptosomal preparation (6).

In addition, different barbiturates modify the partition of brain synaptosomes in a two-phase system as the above described. The effect observed appears to be inversely related to hydrophobicity of the drug and somehow caused by modification of the bioenergetic maintenance of the synaptic membrane ATP-ase (7).

In conclusion, detection of neurotropic agent-induced surface changes of synaptosomal membranes by phase partitioning, may result a potentially useful "in vitro" model to correlate chemical structures with neurochemical or pharmacological characterization of these agents.

- 1.- M. J. López-Pérez, G. Paris and C. Larsson. *Biochim. Biophys. Acta* 635, 359, 1981.
- 2.- J. Sánchez-Prieto and M. J. López-Pérez. *Biochim. Biophys. Acta* 778, 81, 1984.
- 3.- J. A. Enriquez, J. Sánchez-Prieto, T. Muiñp-Blanco, J. Hernández-Yago and M. J. López-Pérez. *J. Neurochem.* 55, 1841, 1990.
- 4.- V. Corbatón, P. Fernández-Gilva, M. J. López-Pérez and J. Montoya. *Neurochem. Res.* 15, 711, 1990
- 5.- J. J. García-Garayo, J. A. Debrián-Pérez and M. J. López-Pérez. *Res. Com. Chem. Pathol. Pharmacol.* 68, 55, 1990.
- 6.- C. Martínez, A. Pérez-Martos and M. J. López-Pérez. *Neurochem. Res.* 14, 865, 1989.
- 7.- M. P. Arregui, A. Pérez-Martos and M. J. López-Pérez. Submitted for publication.

BIOSPECIFIC AFFINITY PARTITIONING OF MEMBRANES

Anders Persson & Bengt Jergil

University of Lund, Dep. of Biochemistry, P.O. Box 124, S-221 00 Lund, Sweden

When fractionating membranes with conventional centrifugation procedures, it is difficult to obtain high purity and yield of less abundant membranes, such as plasma membranes, because of overlapping physical properties between different types of membranes. An alternative approach is two-phase partitioning in aqueous polymer systems. However, as the resolution of membranes is based on subtle surface differences, it is often less useful for bulk preparations.

The introduction of a biospecific ligand, bound to a phase polymer, should allow the purification of membranes according to specific biological properties, rather than physical ones.

We have purified rat liver plasma membranes by affinity partitioning in dextran/poly(ethylene glycol) two-phase systems with a lectin, wheat-germ agglutinin, covalently bound to dextran, as an affinity ligand (*Biochem. J.* (1991) 273, 173-177). In borate buffer the bulk of membranes partitioned in the poly(ethylene glycol)-rich top phase, whereas plasma membranes were pulled selectively into the dextran-rich bottom phase. The affinity procedure, not dependent on lengthy centrifugations, is fast and gentle and will be advantageous when studying labile components.

**The Domain Structure of the Photosynthetic Membrane as
Determined by Fragmentation and Separation Analyses.**

Per-Ake Albertsson, Eva Andreasson, Agneta Persson,
Per Svensson and Shi Gui Yu

Department of Biochemistry, Chemical Center, University of Lund,
P. O. Box 124, S221 00 Lund, Sweden

The structure of the photosynthetic membrane (the thylakoid) from plants is very complex. It consists of different domains which have specialized functions. We have studied this domain organization by fragmentation and separation analysis. By this approach we first fragment the thylakoid by sonication and then separate the fragments which are in the form of vesicles. The different vesicles are then analyzed with respect to pigment and protein composition and also for their photosynthetic activities. The content of each membrane component is then plotted against the content of another component. The diagrams thus obtained are then compared with similar plots obtained from a model of the thylakoid. Our results show that the thylakoid membrane consists of at least three (probably at least four) different domains. A model for the plant thylakoid membrane will be presented.

Reference: 1. Albertsson, P-A. (1988) *Quart. Rev. Biophys.* 21, 61-98

Isolation of cyanobacterial membranes by two-phase partitioning.

B. Norling, V. Mirzakhania, F. Nilsson, B. Andersson, and D.J. Morr *
 Dept. of Biochemistry, Arrhenius Laboratories for Natural Sciences,
 Stockholm University, S-10691 Stockholm, Sweden
 *Purdue University, West Lafayette, IN, USA

Like all gram-negative organisms, the cyanobacterial cell is surrounded by a double-membrane envelope, consisting of an outer membrane and the plasma membrane, and in between a peptidoglycan layer. Also, within the cytoplasm, are found chlorophyll-containing thylakoid membranes organized in concentric layers.

Previous attempts to separate the three different cyanobacterial membranes have been based on sucrose gradient centrifugation of the membrane mixture obtained after lysozyme treatment followed by cell breakage. This method is tedious and gives a very low yield of the plasma membranes and the outer membranes.

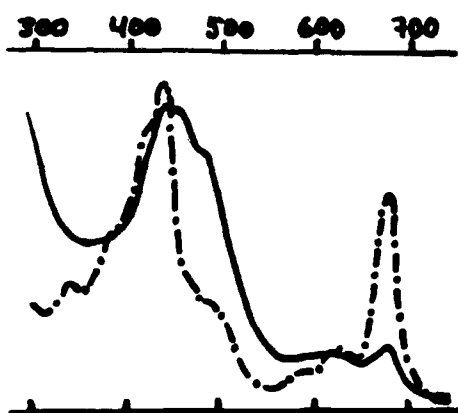

By applying two-phase partitioning on a mixture of the cyanobacterial membranes, using 5.5% dextran and polyethylene-glycol, we obtained a membrane fraction in the lower phase, which is virtually free of chlorophyll as shown by spectral analysis (see figure, solid line). The chlorophyll-free membranes thus isolated have the same density as plasma membranes isolated through other procedures and are therefore suggested to be the plasma membranes. Furthermore, spectral analysis show the presence of carotenoids in the plasma membranes, which may be different from the carotenoids present in the thylakoid membranes isolated from the upper phase of the same two-phase system. (see figure, broken line).

To further characterize this membrane fraction, we are currently investigating membrane morphology, peptide composition and specific enzymatic activities.

(This work was supported by the Swedish Natural Science Research Council and Carl Tr ggers Foundation.)

A chemotaxonomic method for classification of asymmetric penicillia by means of cross-partition in aqueous two-phase systems combined with SIMCA pattern recognition analysis.

Gunnar Ström

Pegasus Separation AB, Box 97, S-751 03 Uppsala, Sweden

Conidia of three strains each of three closely related *Penicillium* species in the *P. viridicatum* group were subjected to cross-partition in aqueous polymer two-phase systems. The cross-point values, the percentage of conidia in the upper phases at the cross-point and at certain pH values, together with growth rate measurements on different culture media were determined and statistically treated using a multivariate classification computer program (SIMCA). The results showed that the different species were well separated, corresponding with the characterization based on mycotoxin production. Moreover, various strains grouped well within the species. The number of culture media, and thereby the number of variables used in the analysis, could be reduced without changing the separation properties.

Stalk cell differentiation in *Dictyostelium discoideum*D.J. Watts*, J. Williams[†], M. Gaskell[†], T.E. Treffry**Department of Molecular Biology and Biotechnology
University of Sheffield[†]Clare Hall Laboratories
Imperial Cancer Research Fund

The life cycle of the cellular slime mould *Dictyostelium discoideum* may include a stage where individual amoebae come together to form aggregates, each of which gives rise to a fruiting body differentiated into spore and stalk cells. This has been seen as a "simple" system in which to study the process by which of cells, believed to be identical initially, take on different characteristics.

Differentiation into stalk cells is induced by DIF (differentiation inducing factor, 1-[(2,6-dihydroxy-3,5-dichloro-4-methoxy)phenyl]-1-hexane)

. Expression of two genes, 56 and 63, has been shown to be specific to pre-stalk cells and controlled by DIF which accumulates in aggregates. Only some of the pre-stalk cells express these genes.

At the beginning of the work described it was known that some cells expressed the 63 gene (but not the 56) but it was suspected that those expressing 56 also expressed 63. TLCCD was used at an early stage in the expression of these two genes to investigate variations in expression among the cell types observed previously.

In order to recognise expression of these genes, cells were transformed with ca. 100 copies each of a vector containing the promoter and upstream sequences of the 56 and 63 genes linked to marker genes (for luciferase and CAT) whose activities could be assayed in the distribution profile.

Expression of the marker genes was pre-stalk cell specific and initiated at the appropriate time in the differentiation sequence.

Aggregates of cells of this transformed strain were harvested shortly after expression of the 56 and 63 genes had been initiated, dissociated into single cells and partitioned at 4°C in a "zero-potential" 5.1% DextranT₅₀₀ 5.1% PEG₄₀₀₀ system (very close to the binodal) using a Bioshef TLCCD. The resulting cell profile was monitored for expression of the 56 and 63 genes by assaying luciferase and CAT activities.

Two separate populations expressed the 56 gene and a single population expressed the 63 gene. Apparently expression of each gene is initially cell-type specific. Further studies using a more sensitive assay indicated that the more hydrophilic of the populations expressing the 56 gene, also expressed the 63 gene. Therefore, there seem to be three responses to DIF; expression of the 56 gene, the 63 gene, or both.

Control of the expression of these two genes by DIF must therefore be seen as rather complex; a complexity revealed in part by the analytical power of TLCCD in aqueous polymer two-phase systems.

1. Town, C.D., Gross, J.D., Kay, R.R. (1977) *Nature* **262** 717-719.
2. Morris, H.R., Taylor, G.W., Mosento, M.S., Jermyn, K.A., Kay, R.R. (1987) *Nature* **328** 811-814.
3. Jermyn, K.A., Duffy, K.T.I., Williams, J.G. (1989) *Nature* **340** 144-146.
4. Sharpe, P.T., Treffry, T.E., Watts, D.J. (1982) *J Embryol Exp Morph.* **67** 181-193.

PARTITION OF MAMMALIAN SPERM POPULATIONS

**ELIZABETH CARTWRIGHT, PAULINE HARRINGTON AND PAUL
T SHARPE**

**Molecular Embryology Laboratory
Department of Cell and Structural Biology
Stopford Building
University of Manchester
Manchester M13 9PT
UK**

TLCCD with charge-sensitive, charge-insensitive and PEG-palmitate phase systems has been used to study the surface heterogeneity of ejaculated bovine sperm and maturing rat sperm.

Ejaculated bovine sperm produce two well-defined peaks when partitioned in charge-insensitive systems. In charge-sensitive phase systems these sperm produce a homogeneous distribution pattern which is insensitive to changes in polymer concentrations. PEG-palmitate-containing phase systems produce the most heterogeneous distribution, partitioning the sperm into at least three sub-populations. We have begun to investigate the molecular basis of these heterogeneities.

We have previously shown that rat sperm show maturation-specific changes in partition as they pass through the epididymis and vas deferens (Gamete Research (1989) 24: 385-392.). Using TLCCD followed by staining with maturation specific monoclonal antibodies we have investigated the heterogeneity of these changes.

Affinity-mediated modifications of electrical properties of cell surface: A new approach in affinity partitioning of biological particles.

Jesús Mendieta and Göte Johansson

Department of Biochemistry, Chemical Center, University of Lund, P.O. Box 124, S-221 00 Lund (Sweden)

Polylysine has been covalently bound to human transferrin in a 1:1 molar ratio over a disulphide bond which can be easily split by reducing agents such as dithiotreitol. The association constant for the binding of the transferrin-polylysine derivative to transferrin receptors present on rat erythroblasts and the number of binding sites were identical to the corresponding values found for native transferrin. The incubation of the cells with transferrin-polylysine affected the partitioning of erythroblasts in a charge-sensitive aqueous two-phase system containing dextran and poly(ethylene glycol). The polylysine part introduced a non-specific influence on the partitioning that could be eliminated by preincubation of the cells with an excess of sialic acid. The partition ratio, G , of the erythroblasts changed with a factor of 1.9 per each set of 100,000 polylysine chains attached per cell. The transferrin-polylysine was also used for fractionation of erythroblasts by CCD.

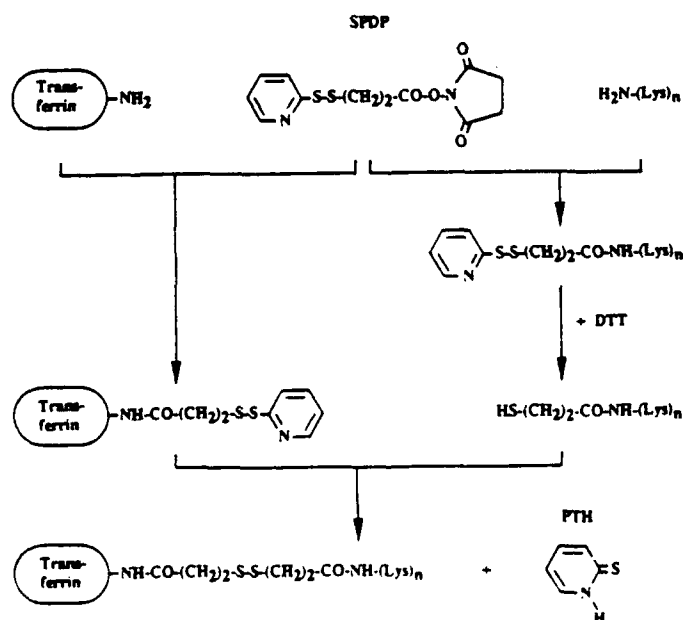

**AFFINITY CELL PARTITIONING:
Lower Limit for Receptor (Antigen sites) Expression and
Strategies for the Extraction of Low Abundance Cells.**

Cristina Delgado, Derek Fisher, Gillian E. Francis
Molecular Cell Pathology, Wellcome Laboratories,
Royal Free Hospital School of Medicine, London, U.K.

José Luque, Jesús Mendieta, Pilar Sancho
Departamento de Bioquímica y Biología Molecular,
Universidad de Alcalá de Henares, Madrid, Spain.

The partitioning of cells in aqueous two-phase systems formed by PEG and dextran can be changed by incubating the cells with a specific PEG-modified ligand (antibody) prior partitioning. We have developed a new approach for affinity cell partitioning (ACP) in which the ligand (antibody) is first reacted with tresylated monomethoxyPEG (TMPEG) in sodium phosphate buffer pH 7.5, the excess TMPEG quenched by reaction with bovine serum albumin and the resulting preparation used directly for incubation with the cells without any isolation of the MPEG-ligand (antibody) conjugates. The versatility of this technique to resolve biological mixtures will be determined by the minimum number of receptors (antigen sites) required to efficiently coat the cell with PEG. In addition, for its application to many biological problems, the method must be capable of extracting a cell population present at low abundance ($< 1\%$) in good yield.

To address the issue of receptor expression we used PEG-transferrin as the affinity ligand and rat reticulocytes as the target cells. The affinity constant of the PEG-transferrin conjugate for the transferrin receptor was first established and thus the PEG-transferrin bound per cell in the incubations leading to increased partitioning could be calculated. The increase in the partition of the reticulocytes takes place within a narrow range of PEG-transferrin bound per cell, 10.2 to 11.3 fg/cell which correspond to 80,000 and 89,000 molecules of PEG-transferrin bound per cell, respectively.

In a model system with human erythrocytes and HL60 cells, MPEG-modified anti-human red blood cell antibody increases the partition of human erythrocytes (up to 100% in top phase) but not the partitioning of HL60 cells (3% in top phase) when either the pure cell populations or mixtures varying from 75% to 10% red blood cells are subjected to ACP. Thus, both cell populations could be completely separated by countercurrent distribution (CCD). However, in cell mixtures where the erythrocytes represents only 1% of the population two factors decrease the efficiency of their extraction. First, the partitioning of erythrocytes is reduced to 50% in the top phase and secondly, even though the separation by CCD of both cell types is theoretically predicted, the low number of erythrocytes in the sample makes them difficult to detect. These problems can be overcome with the following strategy: the cell mixture should be first partitioned, the top phase removed and the bottom phase plus interface extracted again with fresh top phase. By several rounds of extraction of the bottom phase with top phase virtually all the candidate cells are recovered, regardless the contamination with unwanted cells. The top phases are then combined, the cells concentrated by centrifugation and then loaded to the CCD. By using the bulk extraction step prior to CCD the number of cells of interest is proportionally raised so that they can be detected more easily and sufficient cells can be recovered to perform biological analysis.

Purification of HIV and other retroviruses by extraction in aqueous two-phase systems.

Lena Hammar, Department of veterinary virology, Biomedical Center, Uppsala.

In animal retroviruses the protrusions or spikes appearing on the envelope membrane are built from virus-encoded protein units. The spike head contains a highly glycosylated subunit, here referred to as the external glycoprotein (E-protein). This binds the virus to receptors on the target cell and is essential for the infection process. The E-protein is loosely attached to the virus membrane. The general experience is that this protein is poorly recovered with the virion particle after purification by pelleting or banding methods in the ultracentrifuge.

Objective. A great selection of water-soluble polymers are available allowing the design of two-phase systems with various properties. We have investigated the usefulness of such systems for the purification of several retroviruses and their E-proteins¹⁻³. The result from work with HIV-1, HIV-2 and SIVmac will be discussed in particular since with these viruses it was possible to test the infectivity of the purified viruses.

Methodology. To obtain an initial concentration of the virus from relatively large volumes of virus-containing culture medium our approach has been to use systems with a bottom- to top-phase volume ratio of 1:100 or below. Different combinations of polymers were tested, while otherwise the conditions have been kept to physiological saline and pH 7.4. For the extraction plastic transfer bags with attached tubing were found useful. EM, reverse transcriptase assay, ELISA's and western blot analyses were used to trace and quantify the viruses and their subcomponents in the different fractions obtained.

Results. The HIV-1, HIV-2 and SIVmac were concentrated 100-300-fold in dextran-PEG. Other systems were optimal with other viruses. Usually the virus collected in the interphase. In the dextran-PEG systems the infectivity was retained. The E-protein could be further purified by affinity chromatography using different lectins. Preliminary data with detergent-treated virus and further extraction in polymer systems indicate the possibility to design successive extraction steps for the purification of the different viral proteins.

Conclusion. With the appropriate choice of polymers it was possible to obtain a considerable concentration and purification of the viruses while maintaining infectivity and an intact morphology. From the point of view of large scale production and purification of retroviruses the two-phase extraction is an easily handled and economically favorable technique. A further benefit of the systems is that centrifugation of large volumes of virus is avoided, omitting a hazardous step.

References.

1. Hammar L., Eriksson S., Malm K. and Morein B. Concentration and purification of feline leukemia virus (FeLV) and its outer envelope protein gp70 by aqueous two-phase systems. *Journal of Virological Methods* 24, 91-102 (1989)
2. Hammar L., Merza M., Malm K., Eriksson S. and Morein B. The use of aqueous two-phase systems to concentrate and purify bovine leukemia virus outer envelope protein gp51. *Biotechnology and Applied Biochemistry* 11, 296-306 (1989)
3. Hammar L. and Gilljam G. Extraction of HIV-1 in aqueous two-phase systems to obtain a high yield of gp120. *AIDS Res* 6, 1379-1388 (1990)

PARTITIONING AND SEPARATION OF VIRUS LIKE PARTICLES (VLPs)
FROM YEAST CELL DEBRIS USING AQUEOUS TWO-PHASE SYSTEMS

R. Huang, B.A. Andrews, N. Burns* and J.A. Asenjo

Biochemical Engineering Laboratory
University of Reading
P.O. Box 226, Reading RG6 2AP, England

*British Biotechnology Ltd., Cowley, Oxford, England.

Partition in aqueous two-phase systems (ATPS) has many advantages over conventional methods for large scale protein and cell debris separation particularly as these two operations can be achieved simultaneously and the ease of scale up. For intracellular proteins, after cell disruption the protein of interest must be separated from the cell debris and other contaminating proteins. Conventional methods for clarification of cell lysate have many drawbacks which are not encountered in ATPS. ATPS have been studied as an appropriate method to remove cell debris and contaminating proteins from a yeast homogenate containing recombinant protein particles. These particles were VLPs, virus like particles, presently being used for the development of an AIDS vaccine.

The partition behaviour of VLPs, cell debris and contaminating proteins was investigated as a function of changes in the phase components. PEG/Dextran, PEG/phosphate and PEG/sulphate systems were evaluated as well as the effect of PEG molecular weight, the addition of salts (e.g. NaCl) and the pH of the system. As a result of these studies two possible separation strategies were found.

In the first strategy a system with low molecular weight PEG(400 or 600) and ammonium sulphate removed debris (which partitioned to the heavier phase) from VLPs and contaminating proteins. The 'back extraction' is achieved by addition of new phase components to the light PEG phase. Here a PEG with larger molecular weight and either NaCl or phosphate in addition to the sulphate phase-forming-salt removed the contaminating proteins from the VLPs in the heavier phase. In the second strategy, in the first step, a PEG 4000 (or 6000) and either sulphate or phosphate was used to separate VLPs and debris (which partitioned in the interphase) from contaminating proteins in the first stage. In the second stage ('back extraction') a PEG 400 and ammonium sulphate system was used to separate VLPs from cell debris that partitioned to the heavier phase. Advantages and disadvantages of both process strategies will be analyzed and discussed in this paper.

PARTITIONING OF CELLS IN DEXTRAN-POLY(ETHYLENE GLYCOL)
AQUEOUS PHASE SYSTEMS: A STUDY OF SETTLING TIME, VESSEL GEOMETRY
AND SEDIMENTATION EFFECTS ON THE EFFICIENCY OF SEPARATION¹

Harry Walter, Eugene J. Krob and Louie Wollenberger

Laboratory of Chemical Biology, Veterans Affairs Medical Center,
Long Beach, California 90822

The effect of prolonged settling times (up to two hr), in high and low phase columns, on the cell partition ratios measured and on the separability of cell populations was examined. With closely related cell populations, modelled by rat erythrocytes in which subpopulations of red blood cells of distinct ages were labeled isotopically, it was found that partitioning proceeds over the entire time period examined as evidenced by the continuous change in relative specific activity of cells in the top phase as the partition ratio falls. In control cell sedimentation experiments in top phase there was almost no change in the quantity of cells present when vertical settling (i.e., high phase columns) was used and no separation of specific subpopulations was found. In the horizontal settling mode the initially higher cell partition ratio, as compared to vertical settling, decreased to a greater extent with longer times; a given purity of cells only being obtained at a lower partition ratio than in the vertical settling mode. Cell sedimentation in top phase was appreciable with time in the horizontal settling mode but did not result in a separation of cell subpopulations.

The effect of relative cell partition ratios and sizes in high and low phase columns on the efficiency of separation was examined by use of rat or sheep ⁵¹Cr-labeled red cells mixed with an excess of human unlabeled erythrocytes. Rat and sheep red cells are appreciably smaller than human erythrocytes. Rat red cells have higher and sheep red cells lower partition ratios than human erythrocytes. With vertical settling, over a 2 h period, there is no appreciable contribution to the change in relative specific activities by cell sedimentation. However, the more rapid sedimentation of the larger human red cells has, with time, a measurable effect on the relative specific activities obtained during cell partitioning when run in the horizontal mode: enhancing the rat-human and diminishing the sheep-human cell separations.

Partitioning cells in high phase columns is of advantage with respect to increasing separation efficiency and virtually eliminating the influence of other physical parameters (e.g., cell size). Since the cell partitioning process continues for long periods of time, yielding ever-lower partition ratios with increasing proportions of cells with higher P value, a time may be selected which balances desired relative cell purity and yield.

¹J. Chromatogr., in press.

EFFECT OF PERCOLL ON THE CENTRIFUGAL COUNTER-CURRENT DISTRIBUTION OF FROZEN BULL SPERMATOZOA.

M. L. Pascual, T. Muño-Blanco, J. A. Cebrián-Pérez and M. J. López-Pérez.

Departamento de Bioquímica y Biología Molecular y Celular. Facultad de Veterinaria. Universidad de Zaragoza. SPAIN

Previous attempts have been undertaken for achieving the separation of sub-populations of mammalian spermatozoa using thin-layer counter-current distribution (R. A. P. Harrison and N. G. A. Miller, 6th International Conference on Partitioning in Aqueous Two-Phase Systems. 1989 Assmannshausen). These authors showed that ram and boar spermatozoa can be separated into two different sub-populations; one essentially containing cells impermeable to propidium iodide (live) and other permeable to the dye (dead). This was, to our knowledge, the first description of the application of counter-current distribution (CCD) to study spermatozoa heterogeneity.

A shortening of the time needed to perform a CCD run could be of great interest to increase the maintenance of the cell viability during the process. Therefore, we are attempting to establish the experimental conditions by which separation of spermatozoa sub-populations could be achieved by using a centrifugal CCD, in which the time for the separation of the two phases is greatly shortened. Thus, we have undertaken the study of the centrifugal CCD of frozen spermatozoa from bull in a two-phase system containing dextran T500 and polyethylene glycol 6000.

The results obtained showed that the cell distribution profile in centrifugal CCD is different to that obtained in thin-layer CCD, at unity gravity. When centrifugation is used, the cells are mostly found in the lower stationary dextran phase. Sedimentation of the cells in the lower and upper phase of the system used was determined by carrying out some CCD runs only loaded with either upper or lower phase. In these cases, no sedimentation would account for a G value of the cell peak close to 1. G values lower than 1 would mean that cell sedimentation occurs, (and figures higher than 1 would show flotation). The results obtained showed that bull spermatozoa sediment in the upper phase, although this effect was much less important in the lower phase.

In an attempt to avoid the sperm cell sedimentation in the centrifugal CCD, the effect of increasing Percoll concentrations in the cell distribution profile after centrifugal CCD has been studied. Addition of Percoll enhances partition of the cells into the upper phase. Furthermore, as Percoll concentration increases, same heterogeneity of the sperm cell could be observed. These results suggest that the unfavorable effect of sedimentation in centrifugal CCD of cells can be, at least partly counteracted with the addition of Percoll.

RESOLUTION OF PLASMA MEMBRANE DOMAINS OF RAT KIDNEY AND TOAD BLADDER BY AQUEOUS TWO PHASE PARTITION AND PREPARATIVE FREE-FLOW ELECTROPHORESIS ALONE AND IN COMBINATION

Timothy G. Hammond and Rebecca Majewski, Nephrology Section, Department of Medicine, University of Wisconsin Medical School, Madison, WI 53792 and D. James Morr , Department of Medicinal Chemistry, Purdue University, West Lafayette, IN 47907

Aqueous two-phase partition in combination with preparative free-flow electrophoresis were used together with flow cytometry as complementary techniques to isolate and characterize different domains of rat kidney and toad bladder. As these tissues are homogenized, the plasma membranes vesiculate and a critical size threshold is reached where each individual vesicle is representative of a particular plasma membrane domain. With kidney, it is possible to obtain membrane fractions enriched for brush border, basolateral or endosomal membranes by flow cytometry, sucrose gradient centrifugation or preparative-free flow electrophoresis. Additionally, aqueous two-phase partition can be employed as well to rapidly prepare enriched preparations of these same plasma membrane domains. Within each of these different plasma membrane subpopulations, electrophoretic heterogeneity is observed suggestive of the presence of plasma membrane subdomains of differing electrophoretic mobilities.

However, even the availability of fractions enriched in different plasma membrane domains does not satisfactorily address the question of axial heterogeneity of renal proximal tubular transport. To delineate the pathophysiological mechanisms of proximal tubular transport heterogeneity, for example, requires effective new methods for isolating vesicles according to proximal tubule subsegmental origin.

To accomplish the latter, the renal subfractions prepared by aqueous two phase partition and preparative free-flow electrophoresis in series will be further analyzed and separated by flow cytometry. The flow cytometric conditions have been optimized for small particles. The observation volume is reduced by careful focusing of the laser beam on the observation point and using minimal sample core diameter and by minimizing sample to sheath differential pressures. Using fluorescent-labeled ligands specific for different functional parameters associated with the renal surface, it will be possible using this approach to isolate very precise functional domains of the kidney plasma membrane.

A second approach to isolation of plasma membrane domains that employs the complementary techniques of aqueous two-phase partition, preparative free-flow electrophoresis and flow cytometry is that of the extraction, purification and characterization of domain-specific endosomal populations. This approach is being used successfully with the toad bladder where different endosomal populations can be induced using specific ligands. The resultant endosomes are first concentrated by aqueous two-phase partition, further purified by preparative free-flow electrophoresis and finally sorted and identified by flow cytometry using a fluorescent label to the endosome-specific ligand.

FRACTIONATION OF RAT BRAIN HOMOGENATES BY AQUEOUS TWO PHASE POLYMER PARTITION
Dorothy M. Morré, Department of Foods and Nutrition, Purdue University, West
Lafayette, IN 47907

There have been few applications of aqueous two-phase polymer partition to the study of nervous tissue or to the preparation of brain fractions. My laboratory has been interested in investigation of dynamic aspects of membrane renewal in Alzheimer's disease and other brain disorders using autopsy materials. As a prelude to biochemical and molecular studies, we are developing, using both human material and a rat model, a protocol whereby we are able to measure one or more critical parameters of membrane transfer using frozen autopsy materials (D. M. Morré, C. Ferroli, D. J. Morré, M. Andersson and B. Winblad, unpublished results). Using human acceptor membranes immobilized on nitrocellulose and donor membranes prepared from fresh rat brain and radiolabeled with different constituents, we have been able to evaluate effects of variable delay times, time of frozen storage and other parameters. The system measures the capacity of brain membranes to serve as acceptors for vesicle attachment/fusion required to support a vesicle flow mechanism of membrane renewal. Using the cell-free system, it has been possible to demonstrate ATP-dependent and ATP-independent transfer components. Specific transfer (transfer at 37°C) is approximately equal in magnitude to the ATP-dependent component. The strategy under development has the potential to analyze steps of membrane renewal between the endoplasmic reticulum and the plasma membrane reconstituted in a cell-free environment and employing frozen human autopsy material together with animal fractions in steps requiring unfrozen membranes. As the next step, we wished to extend the investigation to donor and acceptor fractions of defined composition. This proved especially difficult with brain due to the extensive amount of myelin present in homogenates. We were especially interested in initially obtaining purified fractions of plasma membranes free of endomembranes and endomembranes free of plasma membranes with both plasma membranes and endomembranes depleted of mitochondria and myelin. In the experiments we will report, aqueous two-phase polymer partition was used in combination with sucrose gradient centrifugation and preparative free-flow electrophoresis to obtain purified plasma membrane and endomembrane fractions from rat brain free of both mitochondrial and myelin contamination. Endomembranes were identified morphologically from their characteristic thin (6 nm) membranes and from the enzyme NADPH-cytochrome c oxidoreductase. Plasma membranes were identified morphologically from their characteristic thick (7 to 10 nm) membranes, a clear dark-light-dark pattern of membrane organization and from 5'-nucleotidase activity.

ISOLATION AND SUBFRACTIONATION OF KIDNEY ENDOSOMES BY AQUEOUS TWO PHASE-PARTITION IN SERIES WITH PREPARATIVE FREE-FLOW ELECTROPHORESIS

Stephen A. Kempson, Mohan Abraham, Hasan Al-Mahrouq and Philip Campbell, Department of Physiology and Biophysics, Indiana University School of Medicine, Indianapolis, IN 46223 and D. James Morr , Department of Medicinal Chemistry and Pharmacognosy, Purdue University, West Lafayette, IN 47907

Endosomes were prepared from rat renal cortex by homogenization using 10 up and down strokes of a loose-fitting glass-teflon homogenizer in a medium containing 300 mM mannitol, and 12 mM HEPES-Tris, pH 7.4. Unbroken cells, large particles and debris were removed by centrifugation for 15 min at 2,500 g. The supernatant was subsequently centrifuged for 20 min at 20,000 g to prepare a crude lysosomal-mitochondrial pellet. The upper yellow layer of the pellet was resuspended in homogenization medium and endosomes were purified by Percoll gradient centrifugation as described (Sabolic et al. 1985, Sabolic and Brown 1990). Alternatively, this pellet was used as the starting material for purification of endosomes by aqueous two-phase partition.

Endosomes obtained from the Percoll gradients frequently were heavily contaminated by mitochondria. To remove the mitochondria, the Percoll gradient-purified endosomes were applied to 5.8% aqueous two-phase systems consisting of equal mixtures of Polyethylene Glycol 3350 (Union Carbide, Fair Lawn, NJ) and Dextran T-500 (Pharmacia, Piscataway, NJ). The tubes were mixed by 40 inversions in the cold, equilibrated to ice-bath temperature and the phases were resolved by low-speed centrifugation. The endosomes entered the upper phase whereas contaminating mitochondria were retained almost quantitatively in the lower phase.

Additionally, aqueous two-phase partition was used as a primary isolation procedure for endosome preparation. The crude 20,000 g pellet was first partitioned against a 6.4% system consisting of equal mixtures of Polyethylene Glycol 3350 and Dextran T-500. The tubes were mixed, equilibrated and centrifuged to resolve the phases. With the 6.4% systems, the endosomes remained in the lower phase, whereas, plasma membranes entered the upper phase and were recovered from the upper phase by dilution and centrifugation. To remove endosomes, the lower phase from the 6.4% partition was repartitioned using a fresh 5.8% upper phase equilibrated with a 5.8% lower phase. After mixing, equilibration and centrifugation, an upper phase enriched in endosomes was obtained whereas contaminating mitochondria remained in the lower phase.

The endosomes purified by aqueous two phase partition were further separated into different populations by preparative free-flow electrophoresis. The most electronegative population of endosomes was identified from a monensin-shift experiment as being a population of late endosomes. Receptor and content markers are being utilized to identify which endosomes represent the intermediate and early populations.

Sabolic, I., Haase, W., Burckhardt, G. 1985. ATP-dependent H⁺ pump in membrane vesicles from rat kidney cortex. *Am. J. Physiol.* 248, F835-F844.

Sabolic, I., Brown, D. 1990. Na⁺(Li⁺)-H⁺ exchange in rat renal cortical vesicles with endosomal characteristics. *Am. J. Physiol.* 258, F1245-F1253.

**A Comparative Study
on two Different Photosystem II Membrane Preparation**

Shi-Gui Yu and Per-Åke Albertsson

Department of Biochemistry, Chemical Center, University of
Lund, P.O. Box 124, S-221 00 Lund, Sweden

Photosystem II particles prepared by detergent treatment of thylakoids (1) have a high photosystem II activity and are almost depleted in photosystem I. These particles which here are called BBY particles, have been very useful for studying various aspects of photosystem II. However, the detergent treatment may cause a loss of the membrane integrity and extract lipids and proteins from the membrane.

As an alternative method we have therefore developed a non detergent method for preparation of photosystem II vesicles (2) here denoted BS vesicles. This involves sonication of thylakoids and two-phase partition in the dextran-PEG phase system. A comparative study shows that this non detergent method allows a preparation of Photosystem II membrane vesicles in a more native state. This conclusion is based on the following results;

1. Counter current distribution reveals that the BS preparation is homogenous (it gives only one peak) while the BBY preparations is heterogenous (several peaks).
2. The antenna size of Photosystem II is larger for BS than for BBY indicating that the connectivity between the chlorophyll-protein complexes has been disturbed in the BBY.
3. The fluorescence emission spectra indicate a shift in the connectivity between the antenna (LHCII) and the core complex of Photosystem II, after the detergent treatment.

- References: 1. Berthold, D.A., Babcock, G.T. and Yocum, C.F. (1981) FEBS lett. 134, 231-234.
2. Svensson, P. and Albertsson, P-Å. (1989) Photosynthesis Research 20, 249-259.

For: 7th International Conference on Partitioning in Aqueous Two-Phase Systems, New Orleans, LA, June 3-7, 1991.

ISOLATION OF ENDOPLASMIC RETICULUM AND GOLGI APPARATUS FROM HOMOGENATES OF SPINACH LEAVES BY AQUEOUS TWO-PHASE PARTITION AND SUCROSE GRADIENT CENTRIFUGATION

D. James Morré, Anna Stina Sandelius and Bertil Andersson, Department of Medicinal Chemistry, Purdue University, West Lafayette, IN 47907, Department of Plant Physiology, University of Göteborg, Stockholm, Göteborg, Sweden and Department of Biochemistry, University of Stockholm, Stockholm, Sweden

Only recently has it been possible to obtain all major membrane and organelle fractions from a single homogenate of green leaves (Morre, et al. 1991). A major difficulty has been the heavy contamination of endoplasmic reticulum and Golgi apparatus fractions by broken fragments of chloroplasts (thylakoids). The fragmented endoplasmic reticulum and Golgi apparatus, while equilibrating at different sucrose densities, are not readily separated from thylakoids by sucrose gradient centrifugation. Similarly, fractions obtained by preparative free-flow electrophoresis enriched in either endoplasmic reticulum or Golgi apparatus also are heavily contaminated by thylakoids. To remove the thylakoids from fractions enriched in endoplasmic reticulum and Golgi apparatus homogenates of spinach leaves by sucrose gradient centrifugation, a procedure based on aqueous two-phase partition was developed.

Plant tissue (leaves, stems, roots) are coarsely cut with scissors and finely chopped in a small amount of medium with razor blades. Homogenization was by mashing with mortar and pestle using 1 to 2 ml medium to 1 g fresh weight of plant material. The homogenization medium was 50 mM HEPES, 10 mM KCl, 3 mM EDTA, 0.01 M ascorbate, 0.1% bovine serum albumin and 5 mM dithiothreitol (pH 7.5) containing 0.4 sucrose. The concentrated homogenates were squeezed through a single layer of Miracloth to remove unbroken cells, cell walls and debris. The homogenates were transferred to 35 or 50 ml centrifuge tubes and nuclei, starch and intact chloroplasts were pelleted by centrifugation for 10 min at 1,000 g using a swing out rotor. The 1,000 g (10 min) supernatant was layered onto a discontinuous sucrose gradient consisting of 4 ml 37% (w/v) sucrose and 8 ml 21.5% (w/v) sucrose in 35 ml tubes. After centrifugation for 30 min at 22,000 rpm (65,000 g, Spinco SW-28 rotor), the membranes at the homogenate 21.5% sucrose interface (for endoplasmic reticulum) and at the 21.5 to 37% sucrose interface (for Golgi apparatus) were collected in separate tubes, resuspended in the clear yellow supernatant from the top of the gradient and pelleted by centrifugation for 20 min at 50,000 g.

To remove contaminating plastids and plasma membranes, the pellets were resuspended in 0.5 ml 0.25 M sucrose containing 5 mM potassium phosphate, pH 6.8 and applied to 4 g two-phase systems consisting of 5.9% (w/w) polyethylene glycol and 5.9% (w/w) Dextran T-500 (Pharmacia). After equilibration to ice bath temperature, the tubes were mixed by 40 vigorous inversions in the cold, reequilibrated to ice bath temperature and the phases resolved by low speed centrifugation. The upper phases (plus the interfaces) and lower phases were collected separately, diluted with centrifugation for 20 min at 50,000 g. The lower phase pellets contained the purified endoplasmic reticulum (homogenate/21.5% sucrose interface) or Golgi apparatus (21.5/37% sucrose interface).

Morre, D.J., Penel, C., Morre, D.M., Sandelius, A.S., Moreau, P. and Andersson, B. 1991. *Protoplasma* 160.

**Electrostatic and Electrokinetic Effects in Two Polymer Aqueous Phase Systems:
What's Happening?**

Donald E. Brooks
Departments of Pathology and Chemistry
University of British Columbia
Vancouver, Canada V6T 2B5

One of the basic features of partition of both macromolecules and cells which has been recognized for over 25 years is that when certain salts dominate in two polymer systems made up with PEG-like molecules the partition behaviour often correlates with the net charge density of the material being partitioned. The salts which produce these correlations, such as phosphates, sulphate and citrate, are known to partition unequally in favour of the non-PEG rich phase, suggesting that a Donnan-type electrostatic potential difference ought to be present between the phases. In principle the presence of such a potential ought to affect the partition coefficient of charged materials, as observed. Attempts to measure the Donnan potential with salt bridges to reversible electrodes have provided data consistent with this picture, but there are problems in the rigorous interpretation of such measurements.

If a potential difference does exist between the interiors of the two phases, it would be expected that the potential between the interface and at least one of the two phases would be non-zero, leading to a zeta potential measurable by electrophoresis of drops of one phase in the other. Such measurements have been carried out and, as has been known for some time, finite and in many cases large mobilities are observed. The sign of the implied zeta potential is *opposite* to that predicted from salt distributions or electrode potential measurements, however. Moreover, when a polyelectrolyte is used as one of the phase polymers the drops rich in charged polymer *move towards the electrode with the same polarity as the charge on the polyelectrolyte*. No satisfactory explanation for these observations has yet appeared. It is a challenge to current theories of electrophoresis of immiscible liquid drops to provide a physical model for the phenomenon and a solution to the problem. In this presentation the data will be reviewed with the hope of generating an enlightening discussion of the issues involved.

COMPARISONS OF REAGENTS FOR IMMUNOAFFINITY PARTITION

L. J. Karr¹, D. L. Donnelly², A. Kozlowsky³ and J. Milton Harris³

1. Space Science Laboratory, NASA/Marshall Space Flight Center, Huntsville, AL 35812.
2. Science and Technology Corporation, 101 Research Drive, Hampton, VA 23666-1340
3. Dept. of Chemistry, University of Alabama in Huntsville, Huntsville, AL 35899

Properties of polyclonal antibody preparations such as antigen specificity, binding affinity, and resistance to denaturation are average values for thousands of slightly differing antibody molecules. Monoclonal antibody preparations however are made up of numerous identical copies of only one antibody molecule. Thus any eccentricities inherent in the molecule are greatly magnified and each monoclonal antibody preparation has its own unique characteristics. While this makes experiments using one monoclonal antibody preparation extremely reproducible, it often causes frustration when trying to devise techniques which will work for all monoclonal antibody preparations.

Purification of cells and proteins by immunoaffinity partitioning using monoclonal antibodies could be enhanced by having an arsenal of reagents from which to choose. To this end, we have compared results using Tresylate-activated straight-chained PEGs (5,000 and 20,000 MW) and branched PEG (14,000 MW) to modify antibodies, Protein G, Protein A, and Avidin.

Because of its higher affinity to rat and mouse immunoglobulin G, recombinant Streptococcal Protein G may have advantages over Staphylococcal Protein A as a general immunoaffinity partitioning reagent using monoclonal antibodies. As it is also more expensive than protein A, it is desirable to use as little as possible.

The PEG-Avidin/Biotinylated antibody system may be appropriate to use for those monoclonal antibodies with lower antigen binding affinities. The Avidin-Biotin bond is very strong, conditions for biotinylation of antibodies are mild, and minimal loss of antibody activity is seen.

In general, PEG (20,000 MW) appears to be more promising than PEG (14,000 MW) and PEG (5000 MW) as less reagent (antibody, Avidin, Biotinylated antibody, Protein G, Protein A) is necessary to produce large changes in cell partitioning with little cell agglutination. Branched PEG (14,000 MW) seems to be the least useful for immunoaffinity partition in that partitioning is not as great into the upper phase and more cell agglutination is seen.

**Preparation of Cibacron Blue F3G-A and Procion Yellow HE-3G
Ethylene Oxide - Propylene Oxide Copolymer Conjugates**

J. Milton Harris and Antoni Kozlowski

Department of Chemistry, University of Alabama in Huntsville

Huntsville, Alabama USA

A method of synthesis of triazine dyes - ethylene oxide-propylene oxide copolymer conjugates for a new phase partitioning method of separation has been elaborated. A commercial ethylene oxide-propylene oxide random copolymer (UCON 50HB 5100, Union Carbide Corporation, EO/PO weight ratio 1:1, molecular weight 4000) has two kinds of hydroxy end groups: primary and secondary, and shows very low reactivity with reactive triazine dyes. The known method of synthesis of polyethylene glycol-triazine dye conjugates is not suitable for preparing conjugates with UCON copolymer.

In the new reaction route, end groups of ethylene oxide - propylene oxide copolymer were converted to epoxy groups by reaction with epichlorohydrin. Solid sodium hydroxide was used as the catalyst for this reaction. In the next step, the epoxy derivative (UCON-epoxide) was reacted with excess of ethylenediamine in ethyl alcohol. After reaction, solvent and excess amine was distilled off. The new derivative (UCON-amine) reacts readily with triazine dyes in a buffer solution. Final products were purified by ion exchange chromatography. Yield of reaction for monofunctional triazine dye Cibacron Blue F3G-A was 24%. The purity of the conjugates was analysed by proton NMR and gel permeation chromatography.

Poly(Ethylene Glycol) Derivatization

Milton Harris
Department of Chemistry
University of Alabama in Huntsville
Huntsville, Alabama

Poly(ethylene glycol)s or PEGs have a variety of interesting properties, which lead to a variety of biotechnical and medical applications. These applications include: two-phase partitioning for biological purifications, PEG-proteins for reduction of immunogenicity and alteration of pharmacokinetics; PEG-coated liposomes for enhanced serum lifetime; surface modification to reduce protein adsorption; use as a tether to bind molecules to molecules and to surfaces; PEG-derived gels for drug delivery; and PEG-peptides for reduced kidney clearance. In this talk I will briefly review these and other applications with a view to future direction and opportunities.

Properties of Immobilized PEG and Applications in Biotechnology

E. Bayer

Institute for Organic Chemistry, University of Tübingen/Germany

Long PEG chains (1.000 - 20.000 daltons) can be grafted on OH-functionalized cross-linked polystyrene beads by anionic polymerization with ethylene oxide. These PS-PEG beads contain up to 90 % PEG, and show equal swelling ratios in solvents which normally dissolve free PEG. The terminal OH-groups can be functionalized, and the kinetics of reactions equals these of PEG in solution. Multi-step reaction sequences can be conducted with high yields and technically easier than in solution because purification only requires filtration.

The PS-PEG beads can be used in continuous flow mode for the synthesis of polypeptides and polynucleotides. The "quasi-homogeneous" kinetics allow coupling cycles between 1-15 minutes. PS-PEG peptides of epitope regions of proteins can be synthesized in a few hours. These PS-PEG-peptides can be used for in vitro and in vivo formation of antibodies without previous conjugate formation or addition of adjuvants. This could be of prime importance for the production of vaccines against virus diseases.

Another application of PS-PEG graft copolymers in biotechnology is affinity chromatography and immobilization of enzymes. Since the beads are pressure stable up to 200 bar enzymatic reactions can be performed with high rates of the educt solution through packed beds. Up-scaling from laboratory to production is easy in this continuous flow operation.

NEW FUNCTIONALIZED POLYETHYLENE GLYCOLS FOR MODIFICATION OF PROTEINS AND GLYCOPROTEINS.

Samuel Zalipsky, Chyi Lee, Sunitha Menon-Rudolph and Robert Ezrielev
Enzon, Inc., 40 Cragwood Road, South Plainfield, New Jersey 07080

Polyethylene glycol-modified proteins are useful as: (a) diagnostic tools and in preparative separations of biological cells or macromolecules; (b) bioreactors in both aqueous and organic media; (c) nonimmunogenic, long-lasting protein-therapeutics. Most of this type of macromolecular conjugates were prepared by a few activated PEGs reactive primarily towards amino groups of proteins.

To extend the arsenal of reagents for preparation of PEG-protein conjugates we developed two new functionalized polymers (1 and 2).



Each of the reagents was prepared via one-pot procedure.

Succinimidyl carbonate derivative of the polymer (1) reacts readily with amino groups of proteins to afford PEG attachment through urethane linkages. Its reactivity is comparable to the previously known succinimidyl succinate derivative of the polymer, with the benefit of considerably improved stability of the linkage between the polymer and protein components.

The second reagent (2) is useful for grafting PEG chains onto proteins and glycoproteins through their carboxyl groups or carbohydrate residues. Water soluble carbodiimide (EDC) was used to activate the carboxyl groups of proteins, thus mediating the coupling of the polymeric hydrazide via diacyl hydrazine linkages. Modification of carbohydrate residues of glycoproteins was accomplished through hydrazone bonds formed between the PEG-reagent (2) and periodate-generated reactive carbonyls. Such hydrazones can be further reduced to very stable N-alkyl- N'-acyl hydrazines by NaCNBH₃. The reagent itself was designed to contain one equivalent of β-alanine per PEG chain. This feature allows reliable determination of the composition of its conjugates by quantitation of β-alanine in hydrolyzates of such conjugates by amino acid analysis.

In our presentation we will discuss the chemistries and scope and limitations of each agent as protein and glycoprotein modifiers.

FRACTIONATION OF PEG-GM-CSF PREPARATIONS BY FPLC AND
IDENTIFICATION OF INDIVIDUAL PEG_n-GM-CSF CONJUGATES BY
PHASE PARTITIONING.

*Cristina Delgado, Farooq Malik, Claudio Knüsli, Manuel Domine,
Owen Smith, Derek Fisher and Gillian E. Francis*

Molecular Cell Pathology, Wellcome Laboratories,
Royal Free Hospital School of Medicine, London, U.K.

Proteins covalently modified with poly(ethylene glycol) have many advantages over their unmodified counterparts. Extended plasma half lives, enhanced bio-availability in vivo and reduced antigenicity and immunogenicity have increased their potential clinical usefulness. PEG modification also leads to increased solubility and resistance to proteolytic degradation; altered kinetics, pH and/or temperature optima and changed substrate specificity of enzymes. Given acceptable (non-denaturing) conditions for the coupling step, there are two main variables that will affect the improved properties of the resulting PEG-protein conjugates. One is the length of the PEG molecules attached and the second is the number of PEG molecules per protein. The former is more easily controlled (by selecting the appropriate PEG parent compound). The latter has proved not to be a trivial issue. Where proteins have several lysine groups, varying the molar ratio of activated MPEG to protein influences the degree of substitution markedly. Preparations are, however, always statistical mixtures of various PEG_n-protein products except at the extremes of modification.

We recently showed that PEG_n-GM-CSF modified to different extents can vary in its biological properties. It is thus important to establish the contribution of individual PEG_n species in a preparation. FPLC reveals heterogeneity reasonably well for preparations made under condition where low degrees of modification are achieved, but fails to resolve the component species in more highly modified preparations. Even in the former, elution rate is not a simple function of the number of PEG molecules added and it is not therefore certain which PEG_n species correspond to each peak. If a combination of FPLC and aqueous polymer phase partitioning are used, the latter gives an additional parameter (the partition coefficient) that can be used to characterise the material in the component fractions. By applying mathematical modelling to test different assumptions about the elution and partitioning behaviour, we have been able to construct mathematical solutions to the composition of PEG_n-GM-CSF mixtures that successfully predict experimental results not used for the modelling process. The comparison of experimental and model derived results allows us to identify the PEG₁, PEG₂, PEG_n adducts. In addition as predicted on theoretical grounds, the relationship between the log partition coefficient and the number of PEG substitutions is linear, further strengthening the validation of the model.

Resolution of a complete series of FPLC profiles into individual Gaussians, allows the kinetics of modification of locations one to six to be calculated. Simple hit theory dictates a similar but not identical relationship suggesting largely stochastic modification of lysines, but some comparatively subtle departures, related presumably to access and susceptibility to nucleophilic attack at individual sites. Whether the accessibility of the different lysine imposes an order for the modification of the first to the sixth amino groups needs to be established.

On the Partitioning of Soluble Molecules in Two-Phase Aqueous
Polymer Systems.

Nicholas L. Abbott
Department of Chemical Engineering, Massachusetts Institute
of Technology, Cambridge MA 02139

Several decades of experimental investigations have revealed a myriad of factors that influence the observed partitioning of soluble molecules in two-phase aqueous polymer systems. Amongst these factors are the types of polymers, their molecular weight and concentration; the size, conformation and composition of the partitioned molecules; the salt type and concentration, and solution pH; and the presence of ligands attached to the polymer which may interact with the surface sites of the partitioned molecules.

Motivated by these experimental investigations, and with the aim of elucidating the molecular-level mechanisms, a number of theoretical descriptions for protein partitioning have been proposed. Theoretical techniques include lattice models, virial expansions, scaling concepts and liquid-state theories.

Through an examination of the physical basis of each of these theoretical formulations, the competing and complementary viewpoints of each approach will be discussed. The connection between theory and experiment will be emphasized, and directions for future developments will be suggested.

Correlation between Partition and Loss of Capacity for
Transepithelial Migration in TnphoA Mutants of Salmonella choleraesuis

Donald E. Brooks, Raymond Norris-Jones, Janice Betts and B. Brett Findlay
Departments of Pathology and Chemistry and Biotechnology Laboratory
University of British Columbia
Vancouver, Canada V6T 2B5

Salmonella choleraesuis, an invasive, virulent organism in humans, was transformed with the TnphoA transposon which produces mutants with fusions in surface proteins identifiable by alkaline phosphatase (PhoA) activity. The resulting 626 strains were tested for their ability to adhere to, invade and cross a polarized monolayer of MDCK epithelial cells (Finlay *et al.* Molecular Microbiology 2: 757 (1988)). A total of 42 strains were unsuccessful in this transcytosis activity. These mutants were assigned to one of six classes on the basis of DNA restriction enzyme digest analysis. They were then examined for PhoA antigenicity and activity, lipopolysaccharide (LPS) profiles, the capacity to adhere to, invade, and alter the electrical resistance of epithelial monolayers and their virulence in mice. None of the six classes of transcytosis mutants adhered to or invaded epithelial monolayers significantly compared to wild type (w.t.) or TnPhoA mutants capable of transcytosis ((+) controls). Class 1 and 2 were found to be LPS mutants, O side chain negative with normal or altered core structure, respectively. Classes 3, 4, 5 and 6 showed w.t. LPS profiles and no other identifiable features associated with fusion protein expression (see above reference for details).

In a search for bacterial surface characteristics which might correlate with the loss of transcytosis capacity we examined the six classes of TnPhoA mutants, w.t. and (+) control strains by partitioning in a variety of two polymer aqueous phase systems. We found that in general *S. choleraesuis* partitioned in favour of the Dx-rich phase in most systems. However, TnPhoA mutation reduced the lower phase partition coefficient of virtually all strains in surface charge-insensitive Dx/PEG/NaCl but not in charge sensitive HPO₄⁻-rich systems, presumably reflecting the presence of PhoA on the bacterial surface. LPS mutants (Classes 1 & 2) were readily distinguishable from all other strains tested by their decreased lower phase partition in charge-sensitive Dx/PEG systems and by their unique upper phase partition in Dx/Pluronic 105/NaCl systems. Three of the remaining four classes (4, 5 & 6) partitioned strongly into the top, Ficoll-rich phase of a Dx/Ficoll/NaCl while all other strains partitioned strongly in favour of the Dx-rich phase. The fourth non-LPS mutant, Class 3, was not distinguished in these systems but the level of PhoA activity and antigenicity in this strain was almost undetectable compared to the others. Hence, compatibility of bacterial surface structures with neutral polymers, as reflected in partition behaviour, appears to be an interesting parameter to explore with respect to the inability of these surface protein mutants to adhere to and invade epithelial monolayers.

We thank the Canadian Bacterial Diseases Network for support.

Prediction of structure and thermodynamic properties of aqueous two-phase systems using integral equations

by

D. Forciniti, P. Kenkare, and C.K. Hall
Department of Chemical Engineering
North Carolina State University
Raleigh, NC 27695-7905

Despite the projected importance of aqueous two-phase extractive techniques for future separations technology, understanding of the molecular basis of protein partitioning in aqueous two-phase polymer solutions is still limited. Our previous experimental study suggests that a more demanding theoretical approach is necessary. We have developed a general comprehensive theory, based in statistical mechanics, of protein solubility in two-phase aqueous polymer solutions with or without added salt.

We explore the utilisation of integral equations, mainly the hypernetted chain (HNC) and mean spherical (MS) approximations, for the prediction of protein solubility in aqueous two-phase systems. Integral equations, such as the HNC or MS approximations, are able to simultaneously handle excluded volume and electrostatic forces. They can be used to predict thermophysical properties (phase diagrams and solubilities) of ionic solutions because they allow the calculation of the pair correlation function provided that the potential of interaction for each pair of species is specified. In aqueous two-phase systems the interactions to account for are: protein-protein, protein-polymer, protein-ion, polymer-ion, ion-ion, and polymer-polymer. Coulombic potentials plus a hard core potential work very well as models of the interaction between ions of the same or different size. The interaction potential between polymers and between polymer and protein can be chosen from the following menu: (a) Polymer and protein can be treated as hard spheres, (b) Polymers and proteins can be treated as soft spheres using the simple molecular-level polymer-polymer and polymer-protein interaction potential previously developed by one of us (R. Csech and C.K. Hall, *Macromolecules* **24**, 1535 (1991)), (c) Polymer and proteins can be treated as attractive hard spheres. In all cases the water molecules are treated as a dielectric continuum background. This means that all of our pair potentials are potentials of mean force.

We have obtained the radial distribution functions and structure factors for each species as a function of various parameters, namely, size and charge of the species, degree of softness, and depth of the attractive potential. In addition, the activity coefficient of each species is calculated. The MS and HNC predictions are compared with each other and with an extensive experimental data bank already generated by us.

A Theory for the Prediction of Protein Partitioning and Phase Composition in Salt-Polymer Aqueous Two-Phase Systems

by

Heriberto Cabezas, Jr.
Department of Chemical Engineering
University of Arizona
Tucson, Arizona 85721, USA

and

Steven M. Snyder and Kenneth D. Cole
National Institute of Standards and Technology
325 Broadway
Boulder, Colorado 80303, USA

ABSTRACT

We have used statistical mechanics as the basis of a general model for the component chemical potentials in aqueous mixtures containing a polymer, a salt, several proteins, and other very dilute minor components. The model has been applied to the a priori calculation of the phase composition and the partition coefficient of several proteins in salt-polymer aqueous two-phase systems. The model contains non-electrostatic and electrostatic contributions. The former are modelled using the solution theory of Hill and the latter are represented by a new model for the electrostatic interactions between charged species of finite size. The Hill theory gives an expansion in solute molality where the coefficients are constant pressure osmotic virial coefficients representing non-electrostatic interactions between pairs or triplets of solute molecules in pure water. Scaling laws giving the polymer molecular weight dependence of these coefficients have been developed from the renormalization group theory of polymer solutions. The leading contributions from the electrostatic interactions between ions in the salt, proteins, and proteins and ions are represented with a new extension of the Debye-Hückel theory. It accounts for the effect of molecular or ion size and short range interactions. The protein and its interactions with other solutes are characterized by the protein diameter or axes, if non-spherical, the protein charge at system pH, and an interaction parameter for the forces between the protein and a monomer of the polymer. The theory for the electrostatic interactions between the protein and the salt was adequate to represent protein-ion interactions without the need for a non-electrostatic protein-ion contribution. No interfacial electrostatic potential of any kind was assumed in the model. The aqueous two-phase systems treated were Na_2SO_4 -polyethylene glycol 1000 and Na_2SO_4 -polyethylene glycol 8000. The partitioning of RNA'ase, Lysozme, and Bovine Serum Albumin were studied in the aforementioned two-phase systems at pH=7.5 and 25°C. Phase compositions and protein partition coefficients calculated from the model were compared to experiment with remarkably good agreement.

**Partitioning of Proteins in Aqueous Two-Phase Systems:
Application of Low-Angle Laser-Light Scattering
and Membrane Osmometry**

C. A. Haynes, H. W. Blanch, and J. M. Prausnitz

Department of Chemical Engineering
University of California, Berkeley, CA 94720-9989

Abstract

Low-angle laser-light scattering data are presented for a series of model partitioning compounds made from modified poly(ethylene glycol) fractions by Kula and coworkers. Partition coefficient data are presented for each of these fractions in both salt-free and salt-containing dextran/poly(ethylene glycol) aqueous two-phase systems. These experiments allow us to differentiate clearly between the effects of electrostatic and nonelectrostatic forces on partitioning.

Low-angle laser-light scattering data are also presented for binary aqueous solutions containing one of eight different globular proteins. Osmotic second virial coefficient data are reported for each of the solutions. For comparative purposes, membrane osmometry experiments are presented for binary aqueous solutions containing *bovine serum albumin* or α -*chymotrypsin*.

Ion-polymer specific-interaction coefficients are determined from osmotic-pressure data for ternary aqueous solutions containing a globular protein and an electrolyte.

Low-angle-laser-light-scattering and membrane-osmometry data are used in a statistical-thermodynamic model useful for predicting thermodynamic properties of aqueous two-phase systems containing polymers, electrolytes, and globular proteins.

Phase Equilibria in Aqueous Two-Phase Systems of Polymers and Salt

H. Hartounian, E.W. Kaler and S.I. Sandler

Department of Chemical Engineering

University of Delaware

Newark, DE 19716

Abstract

Knowledge of how biomolecules partition between aqueous phases and of the factors determining the phase equilibria of solutions of water-soluble polymers is central to the design of large scale aqueous two-phase bioseparation processes.

We have investigated experimentally aqueous PEG/Dextran mixtures and measured the effects of the polymer molecular weight, molecular weight distribution, temperature, ionic strength, salt type on the equilibrium distributions of polymers and ions between two coexisting water-rich phases, and on the fractionation of the polydisperse polymers. Measurement of polymer polydispersity was made spectrophotometrically, HPLC was used to measure polymer compositions and molecular weight distributions, and Atomic Absorption Spectroscopy was used to determine ion activity. Increasing the temperature reduces the concentration of dextran in the dextran-rich phase and increases in the PEG concentration in the PEG-rich phase. Low salt concentrations do not have a significant effect on the equilibrium compositions of the polymers. Due to the polydispersity of the phase-forming polymers there is significant polymer fractionation between the two aqueous phases.

We have developed a general thermodynamic model to predict phase compositions. The model accounts for the effects of the polydispersity of the polymers, temperature, ionic strength and salt type. It combines UNIQUAC solution thermodynamic expressions and extended Debye-Huckel theory to represent respectively short-range and long-range interactions of the polymers and ions in solution. Different activity coefficient conventions are correctly treated and phase equilibrium calculations are made by minimizing the Gibbs free energy. Model calculations are in good agreement with experimental results; in particular the model predicts the observed polymer fractionations.

Analysis of Aqueous Polymer Biphasic Systems Using Modified Flory-Huggins Theory

A. D. Diamond and J. T. Hsu*
Bioprocessing Institute
Department of Chemical Engineering
Lehigh University
Bethlehem, PA 18015
U.S.A.

In order to fully understand the phase separation phenomenon and apply aqueous two-phase systems to the large-scale purification of biomolecules, a simple method is needed for correlating phase compositions and partition coefficients. Utilizing a modified form of the Flory-Huggins theory, a generalized method for correlating biomolecule and phase forming polymer partitioning has been developed. The thermodynamic expression relates the natural logarithm of the partition coefficient for a phase forming component or biomolecule to the concentration difference between the phases for a phase forming component. The parameters of the expression are a function of protein and phase forming polymer molecular weight, the interactions among the partitioning species, and the electrostatic potential difference between the phases. The relationship was verified by partitioning 17 proteins covering a broad range of molecular weight in the poly(ethylene) glycol (PEG)/Dextran, PEG/Salt, and Ficoll/Dextran aqueous biphasic systems, as well as using partition data from the literature. The correlation will facilitate the selection and engineering scale-up of aqueous two-phase systems for biomolecule purification.

**Peptide Hydrophobicity and Partitioning in
Poly(ethylene Glycol)-Salt Aqueous Two-Phase Systems**

Mark A. Eiteman, Dept. of Agricultural Engineering, University of Georgia, Athens, GA 30602

John L. Gainer, Dept. of Chemical Engineering, University of Virginia, Charlottesville, VA 22903-2442

Several peptides were partitioned in poly(ethylene glycol) (PEG)/magnesium sulfate ($MgSO_4$) aqueous two-phase systems. Partition coefficients are shown to be proportional to the difference in PEG concentration difference between the phases. Moreover, the partition coefficients of peptides depend on their relative hydrophobicities, as determined from the individual hydrophobicities of each amino acid residue. Peptides having higher hydrophobicities favor the upper phase (PEG). A series of peptide fragments which comprise the pentapeptide, leucine enkephalin, was also partitioned in the PEG/ $MgSO_4$ system. The results suggest that partitioning of peptides in aqueous two-phase systems depends upon the hydrophobicities of individual exposed amino acids. An additional model, incorporating a measured pH difference between the phases, has been developed to account for the effect of solute charge on partition coefficients. Partitioning results of charged and uncharged analogs confirm the trend predicted.

GENERAL CHARACTERISTIC OF PARTITION ABILITY OF AQUEOUS
POLYMER TWO-PHASE SYSTEMS

Boris Yu. Zaslavsky *

Department of Physiology and Biophysics, Cornell University
Medical College, 1300 York Ave., New York, NY 10021

It is known that the physicochemical properties of water (dielectric relaxation time and static dielectric constant, relative affinity for a CH₂ group, overall polarity as measured by the solvatochromic technique, etc.) in the phases of an aqueous polymer two-phase system are different. Hence partitioning of solutes between the two aqueous phases is considered as similar to that occurring in water-organic solvent two-phase systems.

It has been shown earlier that inorganic salt additives generally change the polymer composition of the phases, the polymer and salt concentrations in the two phases being interrelated as

$$\ln([SALT]_{PEG}/[SALT]_{Dex}) = b_s \cdot \Delta[PEG] \quad /1/$$

where [SALT] is the concentration of a salt (and buffer) in a given phase; indexes "PEG" and "Dex" denote the PEG-rich phase and the dextran-rich phase, respectively; $\Delta[PEG]$ is the difference in the concentrations of PEG in the two phases of a given system; and b_s is a constant the value of which depends on the type and total concentration of the salt and buffer as well as on the type of the phase polymers but not on the polymer concentrations.

Thus the composition and the physicochemical properties of the phases of aqueous two-phase systems of the same total polymer but different salt composition are quite different. It poses the question how to compare and predict the partition behavior of biopolymers in the systems of different ionic composition.

We attempted to answer this question in the present work studying partitioning of several proteins and sodium salts of dinitrophenylated amino acids in aqueous Dex-PEG, Dex-Ficoll, and Dex-PVP two-phase systems of different polymer concentrations and various ionic compositions.

The coefficient b_s of the above relationship between the polymer and salt concentrations in the two phases was suggested as a measure of the overall composition of a given system. Partitioning (expressed as $\ln K$ where K is the partition coefficient) of proteins as well as of Na-salts of DNP-amino acids was found to be linearly related to the above coefficient. The reasons for this relationship are discussed and it is suggested that the parameter b_s is representative of the system partition ability.

* The results reported were obtained by the author and Dr. L.M. Miheeva in Institute of Elementoorganic Compounds, Academy of Sciences of the USSR, Moscow, USSR

AQUEOUS POLYMER EMULSION DEMIXING ON EARTH AND IN SPACE

THE UAH/MSFC RESEARCH PROGRAM

J. M. Van Alstine¹, J. M. Harris¹, L. J. Karr² & S. Bamberger^{2,3}

¹Departments of Chemistry and Biological Sciences, University of Alabama in Huntsville, AL 35899

²NASA/Marshall Space Science Laboratory, MSFC, AL 35815

³National Research Council

NASA interest in aqueous polymer phase partitioning is justified as gravity is the main driving force for the emulsion demixing which, on earth, facilitates the partitioning of biologicals between the phases. Scientific study and modeling of these systems is further recommended as they possess unique physical properties, such as extremely low interfacial tensions. Widespread application of partitioning has suffered due to lack of: suitable automated equipment, techniques specific for bioparticle surface structure, and unified theory regarding the role of gravity and surface chemical factors in determining separation efficiencies. In conjunction with D. E. Brooks et al. (and the Canadian Space Agency) we are successfully addressing the above in a research program encompassing both ground-based and space (i.e. low gravity) research. The latter allows for the study of important cell separation factors difficult to study under the "mask" of gravity (g). Automated apparatus, specific photo-chemical characterization methods, plus surface affinity technologies are under development and being applied to improve bioseparations on earth. This presentation will focus on recent studies in the growing use of the sounding rocket program of the UAH Consortium for Materials Development in Space. Previous experiments indicated that phase system emulsions will demix in low g at a rate commensurate with unique space bioprocessing. Kinetic analysis suggested a coalescence demixing mechanism similar to the brief coalescence stage that initiates the more complicated phase demixing which occurs on earth. This observation is significant given that this stage is seen as an important determinant of cell separation efficiency. Sounding rocket experiments have verified our earlier observations and enlarged our data base to include systems to be used on future Shuttle missions - including one scheduled for May 1991.

EFFECT OF CONTAINER GEOMETRY ON FLUID CONFIGURATIONS IN ZERO GRAVITY

Paul Concus

Lawrence Berkeley Laboratory and Department of Mathematics
University of California, Berkeley, CA 94720

Robert Finn

Department of Mathematics
Stanford University, Stanford, CA 94305

Abstract

The behavior of the free surface of a fluid (or of the interface between two immiscible fluids) in static equilibrium can change qualitatively and even dramatically when an external gravity field is allowed to decrease to zero. A striking illustration of this kind of instability can be obtained using cylindrical capillary tubes of non-circular cross-section. Generally, if the boundary of the cross-section has a corner or is smooth with sufficiently large curvature over a portion of the boundary, then there will be a distinct change in fluid configuration depending on whether the contact angle γ of the interface with the container is less than or larger than a critical value γ_{cr} , $0^\circ < \gamma_{cr} < 90^\circ$ for the wetting case or $90^\circ < \gamma_{cr} < 180^\circ$ for the nonwetting case. These critical values can be determined by a mathematical procedure derived from the classical Young-Laplace equation for capillary surfaces. In connection with another aspect of fluid behavior, an example is given of a container for which there exists an entire continuum of distinct, rotationally-symmetric equilibrium free surfaces all enclosing the same liquid volume and having the same mechanical energy and contact angle. These containers have the further property that the family of surfaces is unstable and certain asymmetric deformations yield surfaces with lower energy. Although such containers can be found for any gravity field, only for microgravity conditions is the scale adequately large to be of physical interest. Results are given of ground-based experiments, preparatory for scheduled space experiments, and of numerical computations to illustrate the phenomena.

ANALYSIS OF TRANSPORT IN DISPERSED PHASE SYSTEMS. AN INVERSE PROBLEM METHODOLOGY

D. Ramkrishna, R. Muralidhar, T. Tobin & H. Wright
School of Chemical Engineering
Purdue University
West Lafayette, Indiana 47907

Abstract

Partitioning of cells, organelles or proteins in two-phase polymer systems involves transport of the foregoing entities from the bulk phase to the interface between the two phases. Recovery of the product must occur by demixing of the dispersed phase droplets. Quantitative predictions of the extent and efficiency of separation require knowledge of the rate of transfer to the individual droplets and the rate of droplet coalescence leading to demixing of the two phases. The usual approach of transport phenomena which consists in analyzing single drops for transport as well as coalescence in well-defined flow situations becomes untenable for droplets in a population setting.

We present here a methodology of dealing with dispersed phase behavior within the framework of population balance. Experimental observations on populations provide crucial input to inverse problems formulated from population balance from which "kinetic" information on rates associated with single drops can be obtained. Thus in the demixing process, dynamic measurements of drop size distributions can be used to obtain size-specific coalescence rates of drop-pairs. The advantage of this approach is that quantitative predictions are possible even in the absence of adequate understanding of basic mechanisms, although it also provides an effective way of directly verifying conjectured mechanisms.

Demonstrations are provided of the inverse problem methodology for droplets in a stirred dispersion by determining size-specific coalescence rates as a function of important experimental parameters such as dispersed phase fraction, ionic strength, pH etc.

We discuss application of the above framework to the separation of cells, organelles and proteins in aqueous two-phase polymer systems. Experiments are suggested from which observations can be gleaned to extract basic information on the separation process which can be used to optimize the partitioning of cells or other entities of interest.

Capillary Surface Reorientation during Brief Periods of Reduced Gravity: Effects of Surface Coatings

Mark M. Weislogel
NASA Lewis Research Center
Cleveland, OH 44135

On earth the effects of surface forces are often overwhelmed by those of gravity, and capillarity dominated processes are thus limited to small geometries (e.g. small capillary tubes, porous media, etc.) satisfying the relation $Bo \equiv \Delta\rho g R^2 / \sigma \lesssim 1$. For a two-immiscible-fluid/solid system, $\Delta\rho$ is the density difference across the interface, g is the acceleration field strength, R is the characteristic length of the system, and σ is the interfacial tension. In the reduced gravity environment of space the above Bond number (Bo) criterion may be satisfied for much larger systems since g approaches 0. As a result, fluid systems in space requiring transport, separation, and/or enhanced stability should exploit, if not simply account for, the effects of wetting and surface tension on a much larger length scale.

The work reported was conducted in two phases. The first phase consisted of a number of qualitative observations made concerning surface reorientation in various partially filled containers in low-gravity environments. The principal reorientation occurred as a result of a discontinuous wetting condition created by using surface coatings on the interior walls of the container. Video recordings of drop tower and KC-135 tests will be presented. Due to the complexity of the three dimensional viscous flows and the general lack of theory by which to address the moving contact line problem, a simplified series of experiments was devised and conducted to quantify the essentially passive reorientation. In this second phase of the study, normal gravity and drop tower tests were performed using capillary tubes with various interior surface coatings. Video data will be presented with an analysis predicting fluid velocities in terms of fluid properties and wetting characteristics. Limitations of the theory and peculiarities of the experimental findings will be discussed.

Electrolyte Transport in Charge-Dependent Two-Polymer Systems:
Application of the Low-Gravity Environment.

Paul Todd, Robin M. Stewart, Scott R. Rudge, and Heriberto Cabezas,
Jr.*

National Institute of Standards and Technology, 325 Broadway,
Boulder, CO 80303, USA. * Department of Chemical Engineering,
University of Arizona, Tucson, AZ 85721, USA.

The movement of ions from one phase into another having a different ionic strength should depend on the ionic strength of the receiving medium. Charged dyes, trypan blue and methylene blue, were allowed to diffuse across a preformed interface between the equilibrated phases of a polyethylene glycol-dextran system with varying phosphate ion concentrations at neutral pH. In some cases convective instability occurred when dye was added, but this was avoided by performing certain experiments in a low gravity environment. In all cases, interfaces were formed using a sliding block device, and any mixing due to sliding was subtracted from the net dye transport across the interface. Transport rates of the dyes were calculated and converted to diffusivities. The calculated diffusivities were compared to theoretical values calculated on the basis of constant-velocity transport due to a balance of the forces on the dye molecule, namely, the chemical potential and the viscous drag. A relationship between diffusivity and the inverse square root of ionic strength was established with no fitted parameters, and this relationship was found to satisfactorily predict dye diffusivity.

A portion of this work was supported by National Aeronautics and Space Administration Contract H-80576B.

BIOPROCESSING SPACE TECHNOLOGY

Dr Ian A. Sutherland, Clive Battle, and Professor Heinz Wolff

Brunel Institute for Bioengineering
Brunel University, Uxbridge UB8 3PH, UK

Gravitation is something we all take for granted and everything we experience, feel, observe or measure is with reference to unit gravity. At Brunel Institute for Bioengineering we work on Space Biology in one department and Rehabilitation Engineering in another. While to most people this seems rather unconnected, we find the juxtaposition of the two departments an exciting one. The difficulties an astronaut has in performing quite simple tasks in zero gravity help us understand and appreciate some of the difficulties people face on earth when their disability is physical rather than environmental. In some cases, in particular Motor Neurone Disease we go to great lengths to simulate a zero gravity environment on earth so that MND patients can utilise their enfeebled muscles to best advantage.

Cells of course are not like people, and it has often been observed that "as man survives in microgravity without any undue effects" that cells, in tissue and in the blood stream, perform just as well in microgravity as they do on earth. Well do they? There is increasing evidence that they do not, and if man is going to survive long term space flight in the future then many more experiments need to be performed in microgravity before we can be confident of long term survival.

It is therefore becoming increasingly important to grow cells in space, both adherent and free cells, for experimental use and for bioprocessing. Brunel Institute for Bioengineering has been involved in developments that will help bring these space flight opportunities nearer: BIOSAMPLE, a fully automated biological workstation intended for the man tended free flyer; BIOLAB a fully equipped laboratory on Columbus for performing and analysing microgravity experiments and BIOST, bioprocessing space technology.

Another long term application of cells in space flight is their potential in closed environmental life support systems. Photosynthetic organisms can consume unwanted carbon dioxide and replace it with oxygen and produce byproducts which can act as a food source. Conventional fermentation techniques rely on convection for aeration, which is not possible in microgravity. This Institute under a contract in collaboration with Dornier Space Systems is developing a small scale closed environmental life support system using a centrifugal fermentation technique, to overcome the problem of aeration in space.

The role of phase partitioning in this scenario is not yet clear. There is considerable promise in using microgravity to learn more about the fundamental behaviour of phase partitioning. Is partitioning diffusion or convection driven? Perfluorocarbon emulsions may be used as oxygen carriers in fermentation processes in microgravity. However the major role of phase partitioning may be to simulate zero gravity here on earth so that we can more cheaply seek solutions for problems that these expensive space flight opportunities pose for us.

A MODEL FOR PREDICTING THE PARTITION BEHAVIOUR OF PROTEINS IN AQUEOUS TWO-PHASE SYSTEMS

J.A. Asenjo, B.A. Andrews F. Hashim and T. Franco

Biochemical Engineering Laboratory
University of Reading
P.O. Box 226, Reading RG6 2AP, England.

Aqueous two-phase systems such as those formed by polyethylene glycol (PEG) and dextran or PEG and salts offer great potential for the separation of proteins in the presence of other soluble materials and cell debris which can be difficult to separate efficiently on a large scale. The main factors that contribute to the overall partition coefficient (K) of a protein between the lighter and heavier phases can be considered as being independent of each other and they include protein hydrophobicity and charge in addition to molecular weight and conformation and effects of ligands in affinity partitioning.

The prediction of partition coefficients of individual proteins is a crucial aim for the design of separation and purification processes based on aqueous two-phase systems. The most important properties of such a system that can be manipulated in the phases, without chemically modifying the polymers as is usually done for biological affinity, are hydrophobicity and charge. This requires the development of appropriate models and correlations to predict their behaviour. Chemical modification of an individual protein to alter a specific property allows the study of the effect of one property in the absence of other effects.

The effect of the molecular weight of a protein in its partitioning is rather well known and recently appropriate models have been developed for the description of affinity partitioning. This paper will describe our present work in the development and evaluation of correlations to describe the partition coefficient of a protein as a function of the proteins hydrophobicity and its total charge. These correlations also allow the evaluation of the 'hydrophobic' difference between the lighter and heavier phase. They were developed for the partition of smaller molecules and have been tested using both model proteins and chemically modified ones where only charge or hydrophobicity of the protein was modified while the rest of the properties were maintained virtually unchanged. For this a number of selected aqueous two-phase systems either with different intrinsic hydrophobicities (in which the effect of protein charge has been neutralized) or with different charge distribution are being used. The use of such a model for a priori prediction of partition coefficients will be discussed as well as the question of hydrophobicity evaluation of the proteins used by a number of available techniques.

ELECTROKINETIC CHARACTERIZATION OF AQUEOUS TWO-PHASE EMULSION DROPLETS

J. C. Baygents*, J. M. Van Alstine† & D. A. Saville‡

*Universities Space Research Association, NASA/Space Science
Laboratory, Marshall Space Flight Center, AL 35812

†Department of Biological Sciences, University of Alabama in
Huntsville, Huntsville, AL 35899

‡Department of Chemical Engineering, Princeton University,
Princeton, N.J. 08544-5263

Abstract

The effect of the electrical double layer on the dynamics of rigid, colloidal-sized particulates immersed in ionic solutions has been studied extensively, from both experimental and theoretical perspectives. Conversely, electrokinetic effects with drops and bubbles, which may have fluid surfaces, are not as well understood. We have examined the electrophoresis of drops and bubbles, computing the electrophoretic mobility as a function of the zeta potential and several other parameters. Our treatment differs from previous analyses in that a more representative picture of the interface is used¹. We find that drops and bubbles are electrophoretically distinct from particles. Perhaps the most striking result obtained is that when the diffuse double layers are thin, conducting drops do not always migrate electrophoretically as anticipated from their surface charge. Thus the zeta potential is not sufficient to electrokinetically characterize the interface. The analysis shows that the migration is dictated by the net electrochemical stress acting along the interface. For similar reasons, large inviscid spheres tend to remain stationary at modest zeta potentials and, in contrast to rigid particles, their mobility is enhanced by polarization of the double layer. The analysis also indicates conditions for which the mobility of nonconducting drops is insensitive to the interior viscosity. This "solidification effect" stems in part from interfacial tension gradients associated with specific adsorption of ionic solutes, as well as from polarization, and need not involve the presence of surface active contaminants.

The model is relevant to aqueous polymer two-phase systems inasmuch as electrokinetic methods have been used to characterize the electrical surface properties of emulsion drops. Selected results will be discussed in relation to new and extant data² on the electrophoretic mobility of APTPS droplets.

1. Baygents, J. C and Saville, D. A., Electrophoresis of Drops and Bubbles, J. Chem. Soc. Faraday Trans., 1991, 87 (12), in press.
2. Brooks, D. E., et al., Electrostatic and Electrokinetic Potentials in Two Polymer Aqueous Phase Systems, J. Colloid Interf. Sci., 1984, 102, 1-13.

A Theoretical Analysis of Aqueous Two-Phase Partition Systems

Y. Guan*, T.E. Treffry*, T.H. Lilley†

*Department of Molecular Biology & Biotechnology and

†Department of Chemistry, University of Sheffield,

P O Box 594, Firth Court, Western Bank, Sheffield S10 2UH, UK

It is very interesting to note that one of the tie lines in the PEG-K₃PO₄ system is the line connecting the solubilities of PEG4000 and K₃PO₄ in water at the temperature tested. Water molecules in this tie line are thoroughly hydrated by solutes contained and no free water is available to bind any additional phase-forming substances. The phase ratio remains the same as the volume ratio in which such saturated solutions are mixed. There seems to be no movement of components between the two previously prepared phases. Data for the partial molar unitary entropy of some ions were examined. The most important fact from them is that divalent ions all decrease the entropy of the final ion-water system to a considerable degree except F⁻ and Li⁺. This reflects the more orderly water structure layer established around these ions of high charge density. These results are in accordance with the fact that most of the anions in phase-forming salts of PEG-inorganic salts of PEG-inorganic salt systems are divalent or trivalent but not monovalent. The phase-forming capacity of three kinds of phosphates, PO₄³⁻, HPO₄²⁻ and H₂PO₄⁻ were compared. The influence of pH on PEG/phosphate two-phase systems was supported by the experimental results. Considering the geometrical distribution of globular proteins in linear polymer solutions, we followed the mathematical treatment of Ogsten and made the following assumptions: (1) the polymer is linear and flexible in the solution; (2) the proteins are globular in shape; (3) small molecules like water and phase-forming salts have negligible resistance to accommodate protein molecules compared with that of the polymer network; (4) the densities of the top and bottom phases are similar and that the molar and weight fractions are proportional; (5) the protein concentration in the system is so small that it has no effect on the initial two-phase equilibrium composition. The following expression was obtained thereafter for protein partition coefficient K_p:

$$\ln K_p = \alpha_1 (kLMp^{2/3} + Mp) (w''_1 - w'_1)$$

where α_1 is the transformation factor from molecular number concentration to weight fraction; Mp is the molecular weight of proteins; w''_1 , w'_1 are the weight fraction of linear polymer in the top and bottom phases respectively; kL is a parameter related to the conformation of linear polymer in the solutions. Some experimental results were compared with this expression.

Furthermore we emphasize the functions of the hydrogen bond and hydrophobic interaction in aqueous two-phase systems. It is proposed that the phase system is formed as a result of competitive hydrophobic interaction of like molecules and hydrogen bond formation of phase-forming molecules with water. Using our own and other authors' experimental results, the influence of urea on the two-phase systems was re-examined according to the denaturing action of urea on proteins. The hydrophobic interaction of PEG molecules is caused mainly by -CH₂- groups in spite of the formation of hydrogen bond of -CH₂O- with water simultaneously. Only a small amount of urea made a significant change in phase transition temperature. The addition of urea mainly affects the interactions between polymer molecules. The other additives and temperatures have the similar influences.

EFFECTS OF FLUID AND THERMODYNAMIC FACTORS ON BIOLOGICAL AND LATEX PARTICLE PARTITIONING

Debra Hawker[‡], Robert Davis[‡], Paul Todd^{*} and Robert Lawson[§]

[‡] University of Colorado, Department of Chemical Engineering, Boulder, CO 80309-0424

^{*} National Institute of Standards and Technology, 325 Broadway 831.01, Boulder, CO 80303-3328

[§] Cell Technology Inc., 1668 Valtec Lane, Boulder, CO 80301

In order to understand how biological particulates partition in aqueous two-phase systems, we studied several factors related to the thermodynamics and fluid dynamics of particle partitioning. The thermodynamic factors studied include interfacial area to volume ratio, amount of sample added to the phase system, salt composition and concentration, and pH. Phase volume ratio, time of phase separation, and gravity force applied during phase separation were studied to provide information on the fluid dynamics of partitioning. The particles studied were ribosomes and vesicles derived from the bacterium *Serratia marcescens* and latex spheres of different sizes and surface compositions. The ribosomes and vesicles from *Serratia marcescens* activate the human immune system, and are components of ImuVert, a product produced by Cell Technology Inc. Factorial design was used in determining the experiments to be performed. The data resulting from these experiments were subjected to ANOVA analysis. It was determined that both the thermodynamic and the fluid dynamic factors studied affect partitioning, and that several of the factors interact to affect partitioning. In addition, the partitioning of ImuVert was optimized for maximum product recovery. A mechanistic model to describe the underlying physics and interactions is being developed.

DESIGN OF MULTISAMPLE, MULTISTEP PHASE PARTITIONING APPARATUS FOR USE ON SPACE SHUTTLE, SPACELAB, AND SPACEHAB MISSIONS

Mark S. Deuser,¹ James M. Van Alstine², John C. Vellinger¹,
Francis C. Wessling², and Charles A. Lundquist²

1 Space Hardware Optimization Technology (SHOT), Inc.
POB 351, Floyd Knobs, In 47119

2 Consortium for Materials Development in Space and
Departments of Chemistry and Biology
University of Alabama in Huntsville

A multisample, countercurrent distribution apparatus has been designed for carrying out partitioning experiments onboard various Space Shuttle missions. The apparatus represent six years of experiments related to low gravity phase partitioning experiment. The compact and modular format of the apparatus allows for a variety of shuttle payload configurations including shuttle middeck locker, SpaceHab locker, Experimental Apparatus Canister (EAC), Get-Away-Special Canister (GAS Can), and Universal Small Experimental Container (USEC). It also allows the apparatus to be configured for control experiments undertaken on the ground, in KC-135 parabolic trajectory aircraft, and in sounding rockets.

The apparatus is composed of two cylindrical disks with precisely bored holes to function as the mixing chambers. When the finely polished surfaces of the two disks are compressed together, the opposing holes in the disks form a series of cuvettes which encapsulate the material samples. The cuvettes are arranged in two concentric rings with each ring containing 12 cuvettes. Countercurrent rotation of the disks over precise increments results in iterative movement of half of the material sample to the adjacent cuvettes.

Material samples can be mixed at each partitioning stage by magnetic stir bars located in each cuvette. These stir bars are driven by magnetic disks mounted on series of pulleys which are coupled together with a small motor. Partitioning is accomplished by directly driving one disk with a separated motor. The operation of the stirring and partitioning functions is controlled by a programmable microprocessor controller, which has the capability to be programmed to meet changing needs for different experiments.

The entire partitioning assembly is mounted in a vacuum-isulated housing, which functions as an integral part of the environmental control system (ECS). The ECS includes a thermoelectric cooler to provide the capability to maintain at lower temperature during the partitioning process. The ECS offers the option of passive latent heat storage to provide non-powered cooling capacity, which could be useful in a variety of shuttle biomaterials processing experiments. The ECS is also controlled by the microprocessor, which can be programmed to accommodate desirable conditions for any experiment.

Phase separation in aqueous mixtures of similarly charged polyelectrolytes

Lennart Piculell*, Lennie Falck†, Svante Nilsson*, Folke Tjerneld† and Karin Bergfeldt*

Departments of Physical Chemistry 1 () and Biochemistry (†)*

University of Lund, Chemical Center, Box 124, S-22100 Lund, Sweden

The phase separation behavior of mixtures of two similarly charged water-soluble polyelectrolytes in water ($PE_1/PE_2/S$ mixtures) has been investigated. In the absence of complexation between unlike polymers, $PE_1/PE_2/S$ systems generally demix (display "incompatibility"). With respect to the phase behavior, $PE_1/PE_2/S$ mixtures are found to more resemble mixtures of uncharged polymers than mixtures of one polymer and one polyelectrolyte. Thus, the sensitivity of $PE_1/PE_2/S$ systems to added salt is much weaker than that reported for mixtures of one polymer and one polyelectrolyte.

For separation applications, $PE_1/PE_2/S$ mixtures introduces new possibilities. For instance, it should be possible to utilize a difference in charge density of the two polyelectrolytes to influence the separation of charged particles. Also, a polyelectrolyte could be made quite hydrophobic while still remaining water-soluble. This could be utilized to influenced the partitioning of partly hydrophobic material.

Effect of surface-attached polyethylene glycol upon lipid polymorphism and vesicle stability in vitro

Colin Tilcock¹, Quet Fah Ahkong¹ and Derek Fisher²

1. Department of Radiology, University of British Columbia, Vancouver, BC, Canada

2. Department of Biochemistry and Molecular Cell Pathology Laboratory, RFHSM, London, UK

Background

The use of lipid vesicles as carriers for the delivery of pharmaceuticals remains an active area of research. In order to facilitate the sustained release and delivery of vesicle-associated drug, various methods have been used to extend the lifetime of the liposomes in the circulation. Vesicles may be made resistant to breakdown by plasma components by using lipids with either saturated or branched acyl chains that are in the gel state at physiological temperature. Alternatively, the surface of the membrane may be masked with gangliosides, glycosides or polyethylene glycol (PEG) [1,2]. In this study we detail the optimal conditions for coupling tresyl-PEG to lipid vesicles containing phosphatidylcholine (PC) and phosphatidylethanolamine (PE), quantitate the binding and examine the effects of the covalently attached PEG on vesicle stability from two perspectives. First, the effect of surface PEG on the polymorphic phase behavior of lipid dispersions was studied by ³¹P NMR and second, vesicle stability was investigated by monitoring the release of the water-soluble fluorescent dye 6-carboxyfluorescein (6CF) upon incubation of the vesicles in plasma.

Results and Discussion

Covalent attachment of tresyl-PEG to PE occurred with low efficiency at pH < 7 and better at pH 8-9. Higher pH values are disfavored due to alkaline hydrolysis of the phospholipid diester bonds. PEGylation was conveniently monitored by partition in aqueous two-phase PEG/Dextran systems using either a fluorescent or radiolabel in the vesicles. A tresyl-PEG to PE ratio greater than unity was required to effect transfer of PC:PE (8:2) vesicles into the upper phase of a 5%/5% w/w PEG 8000/Dextran T-500, 0.01M phosphate, 0.15M NaCl pH 7 phase system. Underivatized PE on the vesicle surface following PEGylation was determined spectrophotometrically after addition of trinitrobenzenesulfonic acid (TNBS). These assays indicated that for a PC:PE (8:2) system, only approximately 35% of the PE on the vesicle exterior (7 % of the total lipid) could be

covalently modified with tresyl PEG 5000, suggesting that the distributed presence of polymer on the membrane surface represents a steric barrier to subsequent attachment. Light-scattering measurements indicated a small increase in vesicle diameter after PEGylation from 115 to 140 nm. Based upon this data and the TNBS labelling results, an approximate value for the PEG concentration at the membrane surface (< 5% w/v) was obtained.

³¹P NMR studies indicated that for lipid mixtures which form stable bilayer phases, covalent attachment of PEG did not cause any lamellar to non-lamellar phase transformations. This finding is consistent with NMR dispersion studies that indicated there was no change in water permeability across the vesicle bilayer after attachment of PEG to the membrane surface and also by studies which showed that upon PEGylation, there was no release of 6CF from the vesicle interior. ³¹P NMR did however show that PEGylation could result in lamellar to micellar transitions for metastable lipid systems indicating that the PEG-modified lipid has a higher cmc than the non-modified lipid. Plasma stability studies showed that PEGylation of the membrane surface either decreased or eliminated the release of 6CF from the interior of the vesicles when they were incubated with plasma. The mechanism by which this protection is conferred is not presently understood, although it is reasonable to suggest that the polymer on the membrane surface may inhibit binding of plasma components to the membrane surface or their penetration into the matrix of the lipid bilayer. In summary, PEG may be coupled to lipid vesicles without any detectable change in the permeability barrier of the membrane. Such vesicles exhibit extended circulation half-lives and are more resistant to disruption in the circulation.

- [1] Klivanov, A.L., Muruyama, K., Torchilin, V.P. and Huang, L. FEBS Lett. 268, 235 (1990)
- [2] Senior, J.H., Delgado, C., Fisher, D., Tilcock, C. and Gregoriadis, G. Biochim. Biophys. Acta. 1991 (in press)

EFFECTS OF CELL EXPOSURE TO DEXTRAN OR POLY(ETHYLENE GLYCOL)

PRIOR TO CELL PARTITIONING

Harry Walter, Timothy J. Webber and Eugene J. Krob

Laboratory of Chemical Biology, Veterans Affairs Medical Center,
Long Beach, California 90822

Cells exposed to Dx-rich bottom phase prior to cell partitioning have lower partition ratios (on single tube extraction) than cells exposed to PEG-rich top phase. Aspects of this previously observed phenomenon [see, e.g., Hill *et al.*, Am. J. Hematol. 21, 249 (1986)] were explored. In the present work charge-sensitive phases made with Dx T500 and PEG 8000 were used exclusively. It was found that:

(1) on countercurrent distribution (CCD) red cells (RBC) loaded in bottom phase have a lower apparent partition ratio, \underline{G} , than the same cells loaded in top phase

(2) when part of the same cell population is loaded into top phase and part into bottom phase of the same load cavities for CCD, with the cells loaded into top or bottom bearing an isotopic tracer (e.g., ^{51}Cr), the cells loaded into top phase have a higher \underline{G} value than the cells loaded into bottom phase

(3) the shift in the CCD curves of human or of rat RBC between cells loaded in top or bottom phase using systems having the same, 5% Dx:3.9% PEG, polymer concentration (though different salt compositions) is not significantly different. RBC from other species tested (beef, sheep) fall into the same range

(4) when the quantity of cells loaded for CCD is reduced, by a factor of 10 (i.e., from 10^9 to 10^8), the partition ratio of cells loaded in top phase is reduced slightly while that of cells loaded in bottom phase is diminished more appreciably

(5) increasing polymer concentrations (e.g., from 5% Dx:3.9% PEG to 5% Dx:4.3% PEG) yield larger differences in \underline{G} values between (rat) RBC loaded in top or bottom phase

(6) when cells exposed to top or bottom phase, respectively, are centrifuged and suspended in bottom or top phase, respectively, their CCD patterns are qualitatively similar to cells exposed to these latter respective phases initially

(7) when cells exposed to one of the phases are washed with saline they give CCD patterns qualitatively similar to cells with no prior phase exposure

(8) rat RBC populations containing ^{59}Fe -labeled cells of different but distinct age are fractionated on CCD irrespective of whether loaded in top or bottom phase. An exception are populations containing very young mature labeled cells (e.g., 4d old) which are resolved when loaded in top phase but not in bottom phase. Glutaraldehyde-fixed rat RBC containing 4d old labeled cells are fractionated by CCD irrespective of whether loaded in top or bottom phase.

USE OF CHEMICALLY MODIFIED PROTEINS FOR INVESTIGATING THE EFFECT
OF CHARGE AND HYDROPHOBICITY ON PARTITIONING IN ATPS

T. Franco, A.T. Andrews* and J.A. Asenjo

Biochemical Engineering Laboratory
University of Reading
P.O. Box 226, Reading RG6 2AP, England.

*Institute of Food Research, Shinfield, England

In order to study the effect of either protein charge or hydrophobicity on its partition behaviour in an aqueous two-phase system (ATPS) in the absence of changes in other molecular and physico-chemical properties we have chemically modified two proteins, thaumatin and bovine serum albumin, BSA. The charges on the protein thaumatin were modified by acetylation to lower its isoelectric point. We have synthesized a number of thaumatin molecules with increased negative or decreased positive charges. Families of modified thaumatin molecules with isoelectric point values (pIs) of 8.5, 5.7 and 4.3 were separated by preparative isoelectric focusing. The original thaumatin molecule has an isoelectric point of 10.5. The maintenance of hydrophobicity between chemically modified thaumatins was checked using hydrophobic interaction chromatography. The behaviour of the modified thaumatin molecules was investigated in PEG/dextran and PEG/phosphate systems in the presence of low concentrations of NaCl and low concentrations of Na_2SO_4 . As such ions partition preferentially to the top or bottom phases under the conditions used in PEG/Dextran systems the partitioning of the positively and negatively charged proteins was studied.

For the modification of hydrophobicity BSA was used and was chemically modified by using anhydrides of different chain lengths. The modified proteins were characterized for surface hydrophobicity by hydrophobic interaction chromatography (HIC) and isoelectric point (by IEF). A linear correlation between the proteins surface hydrophobicity ($\log P$) and partition coefficient was found for selected aqueous two-phase systems with different intrinsic hydrophobicity ($\log P_0$). Using this approach it is also possible to find the intrinsic hydrophobicity of the ATPS.

INTERACTIONS IN AFFINITY PARTITIONING STUDIED USING FLUORESCENCE SPECTROSCOPY.

Patricia Alred Harris, Göte Johansson and Folke Tjerneld

Department of Biochemistry, Chemical Center, University of Lund, P.O. Box 124, S-221 00 Lund, Sweden.

The affinity partitioning behavior of glucose-6-phosphate dehydrogenase (bakers' yeast) and lactate dehydrogenase (rabbit muscle) was studied in two different phase systems composed of either 5.1% UCON 50-HB-5100 (a random co-polymer of 50% ethylene oxide and 50% propylene oxide, MW = 4000) and 7% Dextran T500 or 7% poly(ethylene glycol) 4000 and 7% Dextran T500. The ligand used was the textile dye, Procion Yellow HE-3G. The polymers used as dye carriers were poly(ethylene glycol), Dextran T500, and UCON 50-HB-5100. By varying the ligand carrier but not the ligand itself it was possible to evaluate the effect of the carrier on the binding of the ligand to the target enzyme. The ligand-enzyme interaction was measured by the increase in the partition coefficient, K .

Strong quenching of the enzymes' fluorescence was observed when the ligand was added to the enzyme solution. The excitation wavelength was 280nm, and fluorescence was measured at 330nm. The ligand and ligand carriers were the same as used for the partition experiments, in addition to free (deactivated) Procion Yellow HE-3G. The enzyme was titrated with the ligand in a sodium phosphate buffer solution, pH 7.0, and the change in fluorescence was monitored. This information was used to calculate the association constant, K_A , and the number of binding sites available, n . Both of these values were affected by the ligand carriers. The binding of the ligand was also studied in the upper and lower phases of the same phase systems used for the partitioning experiments. The presence of polymers had an effect on the ligand binding.

Effect of surface-attached polyethylene glycol on lipid mobility and water exchange in unilamellar lipid vesicles: Relevance to the design of liposomal magnetic resonance contrast agents

Colin Tilcock¹, Quet Fah Ahkong¹, Seymour Koenig², Rodney Brown III², George Kabalka³ and Derek Fisher⁴

1. Department of Radiology, University of British Columbia, Vancouver, BC, Canada
2. IBM T.J.Watson Research Center, Yorktown Heights, New York, USA
3. Department of Chemistry, University of Tennessee, Knoxville, Tennessee
4. Department of Biochemistry and Molecular Cell Pathology Laboratory, RFHSM, London, UK

Background

Liposomes with associated paramagnetic species are of interest as both vascular and reticuloendothelial contrast agents, having been shown to improve the detection of hepatic metastases by magnetic resonance (MR) imaging [1]. Vascular enhancement by liposomal MR agents would be improved if both vesicle stability and circulation half-life could be improved. Because water must cross the lipid bilayer in order to interact with paramagnetic species either entrapped within the vesicle interior or on the inner surface of the lipid bilayer, any factor which decreases the water permeability of the membrane causes a decrease in the efficacy of the contrast agent. For this reason the use of saturated lipid species or lipid compositions with high sterol contents is not the best approach to the design of liposomal MR contrast agents with extended half-life in the circulation. Because polyethylene glycol (PEG) can significantly prolong the circulation half-life of liposomes [2], we have investigated whether PEG has any effect upon the relaxivity of paramagnetic species either entrapped within the interior aqueous space of liposomes or attached via a ligand to the surface of the membrane.

Results and Discussion

NMR dispersion studies at 35 °C between 0.02-50 MHz are shown in Figure 1 for vesicle systems with either (a) 100 mM gadolinium tricarboxymethyltetra azacyclodecane (Gd-DO3A) entrapped in egg phosphatidylcholine (PC):dioleoyl phosphatidylethanolamine (PE) (8:2) vesicles sized to 100nm and (b) PC:PE (8:2) vesicles containing 5 mole percent of the lipophilic distearylester-gadolinium complex. Data is shown in the absence and presence of PEG covalently attached to the amine on the surface of the membrane. In both systems, the distributed presence of the PEG on the membrane surface has no effect upon the measured 1/T₁ relaxation rates at any field strength.

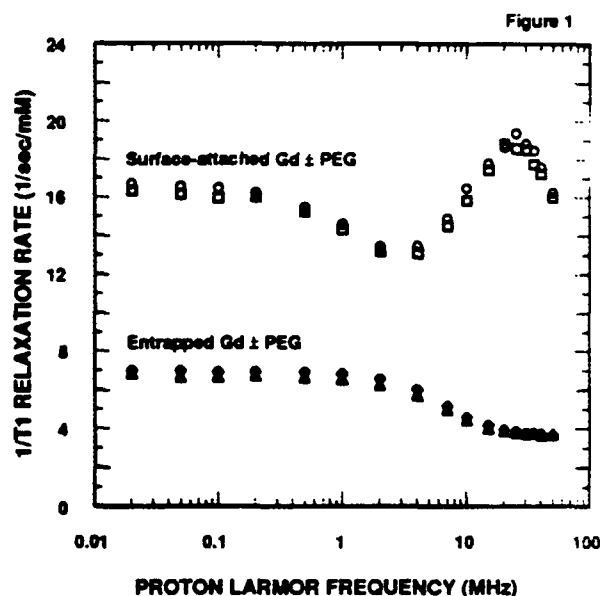

This finding may be rationalized by considering that the timescale for water diffusion between vesicles is much faster than for diffusion of water across the lipid bilayer. Since it is the latter, slower process that limits the ability of water in the bulk phase to sample paramagnetic species on the inside of the vesicle, small changes to the former will have no effect on the measured relaxation rates. Because the relaxation rates are an indirect reflection of water permeability across the lipid bilayer, the more general conclusion may be drawn that in these systems, coupling PEG to the membrane surface has no measurable effect upon water permeability across the lipid bilayer. Covalent attachment of PEG to liposomal MR agents may prove an effective method for increasing their circulation lifetime without decreasing their effectiveness as contrast agents.

- [1] Unger, E., MacDougall, P., Cullis, P and Tilcock, C. *Magn. Res. Imaging* 7, 417 (1989)
- [2] Klivanov, A.L., Muruyama, K., Torchilin, V.P. and Huang, L. *FEBS Lett.* 268, 235 (1990)

APPLICATION OF HIGH SPEED COUNTERCURRENT
CHROMATOGRAPHY/AQUEOUS TWO-PHASE SOLVENT SYSTEM
FOR THE PURIFICATION OF RECOMBINANT PROTEINS

Y. W. LEE AND C. E. COOK, Research Triangle Institute, Chemistry and Life Sciences, P.O. Box 12194, Research Triangle Park, NC 27709-2194

D. C. CHEN AND P. RAY, Division of Molecular Genetic and Microbiology, Burroughs Wellcome Co., RTP, NC 27709

Y. SHIBUSAWA AND Y. ITO, Laboratory of Biophysical Chemistry, National Institutes of Health, Bethesda, MD 20892

Aqueous two-phase solvent systems, typically created by mixing solutions of polyethylene glycol and dextran or polyethylene glycol and specific salts of phosphate or sulfate, have long been employed effectively in the large scale multistage extraction of proteins. By this method, macromolecules and particles can be separated efficiently according to their surface properties, such as size, electric charge and hydrophobicity. In recent years high speed countercurrent chromatography based on the principle of liquid-liquid partition has emerged as a powerful method in the processing of crude natural products and synthetic polypeptides. The integration of an aqueous two-phase solvent system with high speed countercurrent chromatography offers a unique methodology for the purification of proteins. As evidenced in our recent studies, the crude over-expressed recombinant protein, uridine phosphorylase (UrdPase), was conveniently purified with high speed countercurrent chromatography employing an aqueous two-phase solvent system consisting of 16% PEG 1000 (w/w) and 12.5% potassium phosphate buffer (w/w) at pH = 6.8. This system was also effective in the purification of UrdPase extracted from the wild type strain, which is a challenge because of the low concentration of the enzyme. Other recombinant proteins, such as purine nucleoside phosphorylase (PNPase) and thymidine phosphorylase, are being studied.

Based on these encouraging results, high speed countercurrent chromatography employing an aqueous two-phase solvent system will become an important method in analytical as well as semipreparative purification of recombinant proteins.

COUNTERCURRENT CHROMATOGRAPHY OF PROTEINS WITH POLYMER PHASE SYSTEMS USING CROSS-AXIS SYNCHRONOUS COIL PLANET CENTRIFUGE

Yoichi Shibusawa and Yoichiro Ito
Laboratory of Biophysical Chemistry, NHLBI
National Institutes of Health, Bethesda, MD 20892

Y.-W. Lee, Chemistry of Life Sciences
Research Triangle Institute, P.O. Box 12194
Research Triangle Park, NC 27709

Among various coil planet centrifuge systems, the cross-axis coil planet centrifuge has a unique design in that the axes of the rotation and revolution are perpendicular to each other (1). The system generates a three-dimensional fluctuating centrifugal force field which can be effectively utilized for two-phase mixing and retention of the stationary phase. In addition, the system permits continuous elution of the mobile phase through the rotating column without the use of rotary seals which would cause leakage and contamination.

During the past several years, efforts have been made to improve retention of the stationary phase for hydrophilic two-phase solvent systems with low interfacial tension. It has been found that higher retention of the stationary phase can be obtained by laterally shifting the column position along the holder shaft. Our recent model (2) has a 7.5 cm revolution radius (distance between the rotary shaft and the central axis of the centrifuge) and hold a pair of column holders symmetrically one on each side of the rotary frame at a distance of 15cm away from the mid point of the rotary shaft. Each column holder holds a multilayer coiled column consisting of 9 layers of entirely left handed coil of 2.6cm ID PTFE tubing. A pair of multilayer coils is serially connected with a flow tube (0.85mm ID PTFE) to make up a total capacity of about 250 ml.

The two phase solvent systems used in the present study are mostly composed of 12.5% (W/W) PEG 1000 and 12.5% (W/W) potassium phosphate where the partition coefficients of proteins are conveniently adjusted by choosing a proper pH of the phosphate composition. In each separation, the column was first entirely filled with the stationary phase and the sample solution injected through the sample port. Then the apparatus was rotated at 750 rpm while the mobile phase was eluted through the column at a flow rate of 0.5-1.0 ml/min in a proper elution mode. The effluent was continuously monitored with a Uvicord S at 280nm and then fractionated.

The capability of the present system has been demonstrated in separation of a synthetic mixture of stable proteins including cytochrome C, myoglobin, ovalbumin and human hemoglobin (3). The method has been successfully applied to purification of various recombinant enzymes. Our preliminary results indicated that recombinant uridine phosphorylase can be highly purified from a crude *E. coli* homogenate in one step operation in 10 hours (4).

REFERENCES

1. Y. Ito, Sep. Sci. Tech. 22, 1971-2009, 1987.
2. Y. Ito et al., J. Chromatogr. 538, 59-80, 1991.
3. Y. Shibusawa et al., J. Chromatogr. in press.
4. Y.-W. Lee et al., presented at the 1991 Pittsburgh Conference, Chicago, IL

POSTER

**Protein Separation Using Aqueous Two-Phase Systems in the
Eccentric Multi-Layer Coil Planet Centrifuge**

James T. Hsu
Department of Chemical Engineering
Lehigh University
Bethlehem, PA 18015

F. Edward Chou
Pharma-Tech Research Corp.
6807 York Road
Baltimore, MD 21212

Aqueous two-phase systems have been investigated in an eccentric coil planet centrifuge for determining phase stability, back pressure and separation efficiency. Generally speaking, when centrifuge rotational speed is increased, protein resolution is also increased. A rotational speed is then reached after which protein resolution does not significantly change. However, decreasing the flow rate does not improve the resolution. This is caused by extensive diffusion at low flow rates. At high flow rates the resolution disappears; this is due to the lack of time for mixing and settling of both phases. Thus, there is an optimal flow rate for the separation. The relationship between protein separation efficiency, coil diameter, and centrifuge volume has also been studied. The results from this investigation will be used to improve the design of the eccentric multi-layer coil planet centrifuge.

For: 7th International Conference on Partitioning in Aqueous Two-Phase Systems,
New Orleans, LA, June 3-7, 1991

ISOLATION OF ENDOSOMES AND ENDOSOMAL SUBPOPULATIONS BY SEQUENTIAL AQUEOUS TWO-
PHASE PARTITIONING AND PREPARATIVE FREE-FLOW ELECTROPHORESIS

D. James Morré, Department of Medicinal Chemistry and Pharmacognosy, Purdue
University, West Lafayette, IN 47907

The sorting, distribution and processing of receptors, ligands, fluid phase components and membrane proteins internalized via coated pits and coated vesicles takes place in a series of pre-lysosomal compartments referred to as endosomes. By definition, endosomes are a heterogeneous population of prelysosomal, acidic organelles which may play pivotal roles in the sorting and targeting of internalized membranes and content and that direct their specific transport to appropriate intracellular destinations (Mellman et al. 1986). The aggregate of incoming vesicles defines the first major compartment. Some are clathrin coated, some are without coats. They are derived by invagination from the plasma membrane and are modified rapidly by fusion among compartments once internalized. These endosomes are referred to as primary or secondary pinosomes or simply as early pinosomes or early endosomes. The early endosomes as discreet membrane compartments have very short life times and their constituents either recycle back to the plasma membrane or their membranes fuse with other endosomal compartments. Eventually, the contents of the early endosomes are delivered to other endosomes which ultimately become part of the digestive apparatus of the cell. Lysosomes deliver digestive enzymes to the endosomes with the formation of a secondary lysosome or digestive organelle.

The endosomal apparatus exhibits not only a structural heterogeneity but a functional heterogeneity as well. Internalized membrane receptors may be recycled back to the cell surface for reutilization whereas ligands destined for lysosomal digestion are carried forward to the cells' interior giving rise to two broad populations of endosomes designated as receptor positive (early endosomes) and receptor negative (intermediate and late endosomes). By means of pH-sensitive probes, it has been shown that endocytic tracers encounter a gradually decreasing pH as they traverse the endocytic pathway. Thus an acidic internal pH is indicative of late endosomes.

To aid in the determination of the composition of endosomal membranes and to characterize other aspects of endosomal properties, we have begun not only to isolate endosomes but also to subfractionate endosomes into different functional populations. Marsh et al. (1987) were among the first to report that functionally and structurally distinct populations of endosomes could be resolved by preparative free-flow electrophoresis. However, in order to enhance the anodal migration of the endosomes, mild trypsinization was used. In our work, we have utilized aqueous two-phase partition and preparative free-flow electrophoresis in series to prepare endosomes free of plasma membrane and mitochondrial contamination and to begin to subfractionate endosomes without the need for trypsin treatment.

Marsh, M, S. Schmid, H. Kern, E. Harms, P. Male, I Mellman and S. Hellenius.
1987. J. Cell Biol. 104, 875

Mellman, I., R. Fuchs and A. Hellenius. 1986. Ann. Rev. Biochem. 55, 563

AFFINITY-BASED REVERSED MICELLAR PROTEIN EXTRACTION

B.D. Kelley (speaker), D.I.C. Wang, and T.A. Hatton, Department of Chemical Engineering, Massachusetts Institute of Technology, Cambridge, MA 01239.

Reversed micelles are being examined as vehicles for protein extraction from dilute fermentation broths, and have been shown to remove biomass, and concentrate and purify products. This biphasic extraction mimics ion-exchange chromatography, with protein extraction controlled by pH and salt concentration. Greater selectivity can be achieved by employing the principles of affinity chromatography and molecular recognition. By derivatizing hydrophilic ligands such as competitive inhibitors or substrate analogs to form surfactants, they can be incorporated into the reversed micellar interface. These affinity cosurfactants then act to increase the driving force for protein transfer into the extracting phase. Results will be presented for the concanavalin A-alkyl glucoside system, emphasizing the localization of the affinity cosurfactant within the various pseudophases (aqueous, bulk organic, and reversed micelle interface). Binding constants for the biphasic system will be compared to the bulk solution values.

Aqueous two-phase partition: practical comparison with competing and complementary technologies in the biochemical recovery of proteins.

Jonathan G Huddleston, Julia A Flanagan and Andrew Lyddiatt

Biochemical Recovery Group, School of Chemical Engineering,
University of Birmingham, Edgbaston, Birmingham B15 2TT UK

Oral Abstract

The performance of aqueous two-phase partition in PEG-phosphate will be critically compared with that of the competing and/or complementary technologies of ion exchange and bioaffinity adsorption for the recovery of target proteins. Examples will be drawn from an extensive portfolio of fermentation products including murine monoclonal antibodies, intracellular proteins from Saccharomyces, recombinant fusion products from E coli, and extracellular acidic protease from Candida olea (1). Particular emphasis will be placed upon the relative contributions of laboratory analyses to the predictive design and successful implementation of molecular partition.

All strategies for the preferential purification of target macromolecules from complex mixtures exploit selective partition. In chromatography, this operates between liquid and solid phases and process design can be readily initiated on the basis of quantifiable molecular properties. These might include gross estimates of molecular size, shape, isoelectric point or solubility in defined solvent conditions. Bioselective properties might be reflected in binding affinities for immobilised analogs or ligands which mirror or mimic natural interactions. Thus the simple combination of analytical quantitation and laboratory trials can readily establish a chromatographic strategy for defined product recovery.

Such approaches to chromatography have undergone intensive commercialisation in recent years. Successful companies have marketed technologies in tandem with diagnostic aids to enable the definition of the appropriate operating parameters. Electrophoretic titration curves, dye-binding tests and fast chromatographic analyses have all contributed to the widespread application of adsorptive chromatography equipment (2).

On these terms, aqueous two-phase partition compares extremely poorly with such competitive and complementary technologies. Systems must be empirically derived and are consequently unattractive to practitioners requiring predictive design methods. Extensive collections of empirical data, and the development of sophisticated thermodynamic theories, have not defined an analytical approach to working process design comparable with those above. The net result is a poor representation of a potentially powerful technology in laboratory and production scale operations. Salvation must lie in an understanding of the molecular basis of partition (3), and our current work directed toward this goal will be described.

1. Lyddiatt et (1991). Directory of Current Research, Biochemical Recovery Group, University of Birmingham.
2. Technical Literature (Chromatography) Kabi-Pharmacia (1990).
3. Huddleston et al (1991). Enzy and Microb Tech 13, 24.

Real-Time Microscopic Visualization of Column Partitioning

Raymond J. Cronise[†] and James M. Van Alstine^{††}[†]NASA/MSFC Space Science Laboratory, ES76, Huntsville, AL 35812^{††}Department of Biological Sciences, University of Alabama in Huntsville, AL 35899

Müller's work on adapting aqueous polymer two-phase partitioning to column chromatography brings exciting possibilities. Partition Column Chromatography (PCC) is based on separating substances between a stationary phase, localized on chromatographic bead supports, and a mobile phase which is pumped through the bead column. In order to evaluate new phase support beads [1], a flow cell was constructed which provides real-time microscopic evaluation of PCC on a two dimensional column model. PCC offers the advantages of column chromatography (*e.g.* ease of automation and control, use of readily available equipment, large increases in separation efficiency) and the advantages of phase partitioning. The latter include cost effectiveness, ease of adaptation to various separation challenges, biocompatibility, ease of scale up, FDA compatibility, and benefits (*e.g.* good mass transfer rates) related to the liquid-liquid nature of the method. PCC is dependent on the development of suitable support materials [3]. In addition to differential phase "wetting," such materials must exhibit other properties; especially if the technique is to be successfully adapted to particle separations [1,2]. In order to improve or model PCC, it is necessary to evaluate the ability of phase supports to evenly retain phase and form uniform flow channels. This is dependent on bead packing and the thickness, uniformity, and ease of deformation of the stationary phase. Such phenomena are best evaluated "in situ" in order to account for unknown factors such as fluid shear induced by the mobile phase, distortion or loss of the stationary phase due to shear, and the (critical wetting) effects of bead localization on phase properties such as viscosity, solute distribution, and interfacial tension. To evaluate and model particle PCC one needs to account for the location of particles (in either phase and/or at the bead-phase or phase-phase interfaces) as they migrate through the column. One must also ascertain shear-dependent removal of cells with or without accompanying stationary phase. The design and construction of the flow cell will be presented in addition to results obtained using new support materials including glass and stainless steel beads.

[1] Van Alstine, J. M. *et al.*, Abstract in present proceedings.[2] Skuse, D. R. and Brooks, D. E., *J. Chrom.* 1988, 432, 127-135.[3] Müller, W. *Eur. J. Biochem.* 1986, 155, 213-222.

NEW PHASE SUPPORTS FOR PARTITION COLUMN CHROMATOGRAPHY

J. M. Van Alstine¹, R. J. Cronise² and S. Banberger²

¹Department of Biological Sciences, University of Alabama
in Huntsville, Huntsville, AL 35899

²NASA/Marshall Space Science Laboratory, ES76, MSFC, AL 35812

Partition Column Chromatography (PCC) is typically based on separating substances between a stationary dextran-rich phase, localized on chromatographic bead supports, and a polyethylene glycol-rich (PEG-rich) mobile phase which is pumped through the bead column. PCC combines the advantages of column chromatography (e.g., ease of automation and control, readily available equipment, large theoretical plate efficiency) with the advantages of liquid-liquid extraction (e.g., ease of scale up, versatility, cost effectiveness, biocompatibility). PCC is dependent on the development of suitable phase support materials. Müller investigated a large number of supports and developed a series of polyacrylamide coated glass beads which give excellent results for the separation of macromolecules (1). Brooks and Skuse investigated extending PCC to particles via the use of polyacrylamide coated beads. Their results with dextran-T40/PEG-8000 systems suggested a single step partitioning process whose efficiency exceeded that of single-tube separations, when used in conjunction with a custom-produced PEG-alkyl hydrophobic affinity ligand (2).

We are attempting to improve PCC via the development of autoclavable supports capable of preferentially wetting the dextran-rich phase independent of covalent modification with polyacrylamide or other polymers. This eliminates problems due to the ablation or hydrolysis of a coating which, even when new, may promote non-specific adsorption of biosubstances onto the support material. The new supports hold particular promise for particle separations. In order to reduce nonspecific particle-bead interaction we are using commercially available, biocompatible, PEG-surfactant in dextran-T500/PEG-8000 systems. The advantage of the T-500 systems is their tendency to partition particles between the PEG-rich phase and the phase interface, reducing particle interaction with the stationary phase. In order to reduce trapping particles on the column we also employ relatively large, homogeneously-sized, beads and filters.

1. Müller, W., Eur. J. Biochem. 155 213-222 (1986).

2. Skuse, D. R. and Brooks, D. E., J Chromatog. 432 127-135 (1988).

CHARACTERIZATION OF SPIROCHETE MEMBRANE IMMUNOGENS USING TRITON X-114 PHASE PARTITIONING. Justin D. Radolf, M.D. and Michael V. Norgard, Ph.D. Depts. of Internal Medicine and Microbiology, U. T. Southwestern Medical Center, Dallas, TX 75235.

Triton X-114 (TX114) and Triton X-100 (TX100), both members of the polyoxyethylene family of nonionic detergents, share many physical and biochemical properties. However, one notable difference between the two surfactants is the much lower cloud point of TX114 (20° C) as compared to that of TX100 (64° C). The relatively low cloud point of TX114 enables proteins solubilized with this detergent to be partitioned into detergent and aqueous phases; amphiphilic (i.e. integral membrane) proteins partition into the heavier, detergent phase. Since its initial description by Bordier in 1981 (J. Biol. Chem. 256: 1604-7), TX114 phase partitioning has become a valuable tool for the analysis of membrane proteins from complex biological systems.

TX114 phase partitioning has been employed in our laboratories to characterize the membrane immunogens of *T. pallidum* and *B. burgdorferi*, the spirochete bacteria which cause syphilis and Lyme disease, respectively. With this technique, it was demonstrated that the major immunogens of both organisms are predominantly integral membrane proteins. Further refinements of this methodology enabled fractionation of each organism into outer and cytoplasmic membrane compartments as well as isolation and reconstitution of their respective outer membranes. The discrepancy between the demonstrated amphiphilicity of the membrane immunogens and their hydrophilicity (predicted by DNA sequence analysis) was an important indication that the major membrane immunogens of both spirochetes are covalently modified with fatty acids; acylation of both the native and cloned immunogens subsequently was confirmed both genetically and biochemically. Moreover, it also has been demonstrated that the fatty acid moieties provide membrane anchors for the hydrophilic polypeptides. Finally, TX114 phase partitioning has become an important first step for purification of these membrane proteins for immunological analyses. Thus it has been found most recently that these lipoprotein immunogens are potent activators of both T cells and macrophages, properties that may help to explain the clinical manifestations of syphilis and Lyme disease. Preliminary data suggests that their immunological activities also depend upon the fatty acid substituents. We have hypothesized that, following liberation of the lipoproteins from the spirochetes, the fatty acid moieties enable these proteins to insert into the plasma membranes of host immune effector cells where they activate cellular signal transduction apparatuses.

Isolation and Purification of Substances with Aqueous 2-Phase Systems without Addition of Salt

R. Heusch , Leverkusen , Deutschland

We could show that there is a competition between water structures and structureforming surfactants in aqueous surfactants systems(1). In an aqueous 2-component system existing of surfactant and water dominate by high surfactant concentration hydrogen bonds and form hydrate complexes. In these complexes the water molecules are attached in whole multiples to the hydrogen atoms of the hydrophilic groups of the surfactant molecules(1)(2). At high water concentration hydrophobic interactions become important. They dissolve the hydrate complexes creating water zones surrounded by hydrated surfactant lamellae, which become mobile as the water concentration increases, causing anomalous viscosities.

If temperature increases the hydrophilic lamellae looses the water stepwise so that in the missibility gaps hydrophobic lamellae exists.

With the change of the hydrat structure it will be possible that in the missibility gap hydrophobic substances can be isolated(3). It will be demonstrated, how in aqueous 2-phase systems hydrophobic substances like receptors(4) or hydrophobic pigments, pharmaceuticals(5) or crop protections can be isolated or purified without addition of salt.

In 3-component systems it will be possible to produce or purify more hydrophilic substances in 2 aqueous phases. You can vary the hydrophobic character of the organic solvent(6).

(1) R. Heusch, Ber.Bunsenges.Phys.Chem. 95(1991) im Druck

(2) R. Heusch, Tenside Surf. Det. 28(1991)38

(3) R. Heusch, BTF-Biotech-Forum 3(1986)1

(4) F. Fopp et al., Tenside Det. 23(1986)3

(5) Deutsche Patent-Anm. P 3817957-1 vom 27.5.1988, Bayer-Höchst

(6) P. Miethe et al., Biotech. Letters 11(1989)449

ADVANCES IN METAL-AFFINITY SEPARATIONS

Pradeep Dhal, Bong Hyun Chung and Frances H. Arnold
Division of Chemistry and Chemical Engineering 210-41
California Institute of Technology
Pasadena, California 91125

The development of cost-effective affinity separations will eventually require that expensive and labile biological affinity ligands be replaced by small chemical mimics. Metal complexes have a number of features that make them ideal candidates for such mimics, and they can be exploited in a wide variety of separation modes. This presentation will cover recent results from our work on new metal-affinity separations. Metal-affinity partitioning of phosphoproteins using Fe(III)IDA-PEG in PEG/dextran two-phase systems provides a useful method for characterizing and isolating phosphorylated proteins. A mathematical framework for analyzing partition coefficients that includes the effects of competition by H^+ and OH^- has been developed and successfully applied to obtain Fe(III)-phosphate binding constants. In addition to our work on metal-affinity protein partitioning, we have begun to develop a new class of metal-chelating polymers that exhibit selectivity for individual proteins. Designed for metal-affinity or ligand-exchange adsorption separations, these polymers contain arrays of metal ions that bind complementary arrays of functional groups on the surface of the target molecule. The novel feature that determines the selectivity of recognition in separations is to match the spacing of metal ions in the polymer to the spacing of metal-coordinating functional groups on the target molecule. Metal-chelating polymers synthesized in this laboratory are capable of distinguishing small protein analogs that cannot be separated by other powerful methods, including reverse phase HPLC and ligand-exchange chromatography.

Electrohydrodynamic Considerations for Electric Field -
Driven Phase Separation

R. S. Snyder, P. H. Rhodes
Space Science Laboratory
Marshall Space Flight Center

The fractionation of biological molecules is frequently enhanced by combining separation methods and taking specific advantage of each. The conduct of these methods sequentially has yielded significant enhancement of separation resolution, as illustrated by two dimensional electrophoresis. However, when these methods are combined in parallel in order to reduce time and operation, problems can arise from interactions between the different forces driving the processes.

Combining electrophoresis and phase partitioning has the potential for this problem. Our electrophoresis experiments with discontinuities in conductivity and dielectric constant within the fluid phase were disturbed by fluid flow that we have identified as electrohydrodynamics. Distortion of the sample bands occurred in both ground and space experiments. This phenomena, previously observed only in droplet systems under high field conditions, must be controlled during electrophoresis of phase systems.

A Tale of Two Systems: Methods for Aspartame Synthesis
in Organic Media

C. Bull, A. Gross, J. F. Walter

We will present an enzymatic process for aspartame production which uses a single phase mixture of water and acetonitrile. The high organic content of this solvent precipitates the enzyme, a neutral protease which retains its coupling activity in this slurried state. Over 95% conversion can be achieved in 10% water, and catalyst stability in excess of 30 days has been demonstrated.

A complementary pathway was developed based on stereoselective synthesis of L-erythro-phenylalanine to synthesize aspartame. We developed a two-phase enzymatic synthesis which gives surprising selectivity for the desired phenylserine isomer. Both methods involved novel bioreactor designs.

Protein Separations with Two-Phase Electrophoresis

William M. Clark, Charles W. Theos, and Michael A. Marando

Chemical Engineering Department
Worcester Polytechnic Institute
Worcester, MA 01609 USA

Efficient, and in some cases, large-scale protein separations are essential to the continued success of the biotechnology industry. Electropartitioning, or two-phase electrophoresis, represents an attempt to combine the scalability of partitioning in aqueous two-phase systems and the high resolution of electrophoresis into an efficient separation process for proteins and other charged species. In this technique, an electric field is applied perpendicular to the phase interface of an aqueous two-phase system to alter partitioning of charged species between the phases and reduce phase separation time. The technique may also be viewed as a new form of electrophoresis in which a stable liquid-liquid interface, rather than a gel or membrane, is employed to separate two regions and avoid convective mixing.

Two separation devices have been constructed to perform two-phase electrophoresis: one batch and the other continuous flow. In the batch apparatus, a two-phase solution is charged into a working chamber sandwiched between two electrode chambers at the top and bottom. Dialysis membranes separate the working chambers from the electrode chambers and retain the phase forming polymers and proteins but allow passage of electrical current. In the flow apparatus, a well mixed two-phase system is introduced into a long narrow channel separated from electrode channels on the top and bottom by dialysis membranes. As the two-phase solution passes through the channel, the phases separate and proteins are caused to migrate from one phase to the other under the influence of a vertically directed electric field. Withdrawal ports at the end of the working channel allow continuous flow of top phase, bottom phase, and interface fractions at rates which are individually controlled by metering pumps.

The apparent partition coefficient of a protein can be significantly increased or decreased from the equilibrium value by application of an electric field on the order of 30 V/cm. The magnitude and direction of the change in partition coefficient depends on protein net charge, location of the anode and cathode, buffer conductivity, time of electrophoresis, and the viscosities of the two phases. Studies of the factors governing migration have been made for several proteins including myoglobin, hemoglobin, bovine serum albumin, lysozyme and cytochrome-c in both the batch and the continuous flow electropartitioning devices. Binary separations of charged dyes and proteins have also been studied.

ELECTROPHORESIS OF SOLUTES IN AQUEOUS TWO-PHASE SYSTEMS

Mark Levine, Heriberto Cabezas, and Milan Bier
Center for Separation Science, Dept. of Chemical Engineering,
University of Arizona, Tucson, AZ 85721

Several investigators have tried to combine electrophoresis and aqueous two-phase systems for reasons such as disengagement of the emulsified phases. We have chosen to focus on the behavior of solutes at the interface of these systems under the influence of the applied field. This electric field has been shown to be insufficient to transport a protein across the interface from preferred to non-preferred phase in both free fluid and gel electrophoresis. Instead, the protein accumulates at the interface. Transport in the opposite direction is easily accomplished. The magnitude of this phenomenon is related to the value of the partition coefficient. This effect has important consequences in explaining the distribution of solutes in a phase system after it has been disengaged by electrophoresis, as well as in processes such as electrochromatography. Some novel separations of substances based on their electrophoretic behavior at the interface will be demonstrated. We have also begun evaluating several models for these systems, based on extensions of current electrophoretic theory, which will be discussed. This work was supported in part by a grant from the NASA Graduate Student Research Program, No. NGT-50270.

Electrokinetic Demixing of Two-Polymer Systems: Role of Dissolved Phosphate Ions.

Paul Todd, Robin M. Stewart, K. S. M. S. Raghava Rao and Scott R. Rudge.

National Institute of Standards and Technology, 325 Broadway, Boulder, CO 80303, USA.

The application of electric fields of up to 25 V/cm can reduce demixing times more than 5-fold in 100 mL systems of polyethylene glycol (PEG) and dextran or PEG and maltodextrin. Enhancement of demixing by applied electric fields depends, among other things, on phosphate ion concentration. Experiments were performed to determine the role of the valency of the phosphate ion in electrokinetic demixing. The ionization of phosphate was controlled by varying pH over five values between 5.5 and 8.1. The demixing times at pH 8.1 were at least five times those at pH 6.2. While it is clear that the phosphate ion contributes directly to the electrokinetic demixing process, these data leave unsolved the nature of the chemical process, as the pH dependence was greater than expected when the net charge was varied only 2-fold.