

2

# NAVAL POSTGRADUATE SCHOOL Monterey, California

AD-A248 632



DTIC  
SELECTE  
APR 20 1992  
S B D

## THESIS

Survivability of Meteor Burst  
Communication Under Adverse  
Operating Conditions

by

Mark A. Gates

March 1992

Principal Advisor:

Thomas A. Schwendtner

Approved for public release; distribution is unlimited

92-09851



02 4 10 059

REPORT DOCUMENTATION PAGE			
1a REPORT SECURITY CLASSIFICATION <b>Unclassified</b>		1b RESTRICTIVE MARKINGS	
2a SECURITY CLASSIFICATION AUTHORITY		3 DISTRIBUTION/AVAILABILITY OF REPORT Approved for Public Release; distribution is unlimited	
2b DECLASSIFICATION/DOWNGRADING SCHEDULE			
4 PERFORMING ORGANIZATION REPORT NUMBER(S)		5 MONITORING ORGANIZATION REPORT NUMBER(S)	
6a NAME OF PERFORMING ORGANIZATION Naval Postgraduate School	6b OFFICE SYMBOL (if applicable) EC	7a NAME OF MONITORING ORGANIZATION Naval Postgraduate School	
6c ADDRESS (City, State, and ZIP Code) Monterey, CA, 93943-5000		7b ADDRESS (City, State, and ZIP Code) Monterey, CA, 93943-5000	
8a NAME OF FUNDING/SPONSORING ORGANIZATION	8b OFFICE SYMBOL (if applicable)	9 PROCUREMENT INSTRUMENT IDENTIFICATION NUMBER	
8c ADDRESS (City, State, and ZIP Code)		10 SOURCE OF FUNDING NUMBERS	
		Program Element No.	Project No.
		Task No.	Work Unit/Account Number
11 TITLE (Include Security Classification) <b>SURVIVABILITY OF METEOR BURST COMMUNICATION UNDER ADVERSE OPERATING CONDITIONS</b>			
12 PERSONAL AUTHOR(S) Mark A. Gates			
13a TYPE OF REPORT Masters Thesis	13b TIME COVERED From To	14 DATE OF REPORT (year, month, day) 1992 MARCH	15 PAGE COUNT 76
16 SUPPLEMENTARY NOTATION The views expressed in this thesis are those of the author and do not reflect the official policy or position of the Department of Defense or the U.S. Government.			
17 COSATI CODES		18 SUBJECT TERMS (continue on reverse if necessary and identify by block number)	
FIELD	GROUP	SUBGROUP	
		Meteor Burst Communication	
19 ABSTRACT (continue on reverse if necessary and identify by block number) This thesis is a study of the survivability and reliability issues associated with operating meteor burst communication systems under adverse conditions. Meteor burst communication relies on the phenomenon of reflecting radio waves off the ionized trails left by meteors as they enter the atmosphere and disintegrate. The systems' rapid deployment capability, mobility, and operating characteristics make it ideal for disaster and emergency communications. Adverse conditions such as ionospheric disturbances, polar region anomalies, sun-spot activity, the nuclear EMP environment and others are discussed.			
20 DISTRIBUTION/AVAILABILITY OF ABSTRACT <input checked="" type="checkbox"/> UNCLASSIFIED/UNLIMITED <input type="checkbox"/> SAME AS REPORT <input type="checkbox"/> FOR USERS		21 ABSTRACT SECURITY CLASSIFICATION Unclassified	
22a NAME OF RESPONSIBLE INDIVIDUAL Thomas A. Schwendtner		22b TELEPHONE (Include Area code) (408) 646 2535	22c OFFICE SYMBOL EC SC

Approved for public release; distribution is unlimited.

Survivability of Meteor Burst  
Communication Under Adverse  
Operating Conditions

by

Mark A. Gates  
Lieutenant, United States Navy  
B.A. , Miami University, 1985

Submitted in partial fulfillment  
of the requirements for the degree of

MASTER OF SCIENCE IN TELECOMMUNICATIONS SYSTEMS  
MANAGEMENT

from the

NAVAL POSTGRADUATE SCHOOL  
March, 1992

Author:



Mark A. Gates

Approved by:

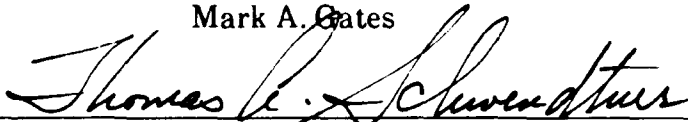

Thomas A. Schwendtner, Principal Advisor

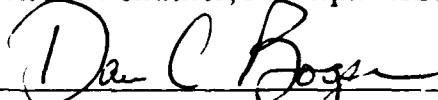

Dan C. Boger, Associate Advisor

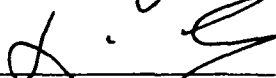

David R. Whipple, Chairman  
Department of Administrative Sciences

**ABSTRACT**

This thesis is a study of the survivability and reliability issues associated with operating meteor burst communication systems under adverse conditions. Meteor burst communication relies on the phenomenon of reflecting radio waves off the ionized trails left by meteors as they enter the atmosphere and disintegrate. The system's rapid deployment capability, mobility, and operating characteristics make it ideal for disaster and emergency communications. Adverse conditions such as ionospheric disturbances, polar region anomalies, sun spot activity, the nuclear EMP environment, and others are discussed.

<b>Accession For</b>	
NTIS GRA&I	<input checked="" type="checkbox"/>
DTIC TAB	<input type="checkbox"/>
Unannounced	<input type="checkbox"/>
Justification _____	
By _____	
Distribution/	
Availability Codes	
Dist	Avail and/or Special
A-1	

## TABLE OF CONTENTS

I.	INTRODUCTION . . . . .	1
A.	PURPOSE . . . . .	1
B.	STRUCTURE . . . . .	1
II.	METEOR BURST OVERVIEW . . . . .	3
A.	INTRODUCTION . . . . .	3
B.	SYSTEM CHARACTERISTICS . . . . .	4
1.	Operating Frequency . . . . .	9
2.	Data Rate . . . . .	9
3.	Transmitter Power . . . . .	10
4.	Antenna Design . . . . .	10
5.	Threshold Level . . . . .	14
C.	EXTERNAL NOISE . . . . .	16
1.	Galactic Noise . . . . .	16
2.	Atmospheric Noise . . . . .	16
3.	Man-made(artificial) Noise . . . . .	17
D.	INTERNAL SYSTEM NOISE . . . . .	20
E.	TRANSMISSION LOSSES . . . . .	20
1.	Scatter Loss . . . . .	20
2.	Free-space path loss . . . . .	22
F.	ADVANTAGES/DISADVANTAGES . . . . .	22
1.	Advantages. . . . .	22

2.	Disadvantages . . . . .	23
G.	APPLICATIONS . . . . .	24
1.	Long-haul communication . . . . .	24
2.	Remote Monitoring . . . . .	27
3.	Position Monitoring . . . . .	28
III.	SURVIVABILITY OF METEOR BURST COMMUNICATIONS . . . . .	30
A.	INTRODUCTION . . . . .	30
B.	THE EFFECTS OF IONOSPHERIC DISTURBANCES . . . . .	31
C.	THE EFFECTS OF EXTREME SOLAR ACTIVITY . . . . .	34
1.	Sun spots . . . . .	34
2.	Solar flares . . . . .	35
a.	Sudden Ionospheric Disturbances (SIDs) . . . . .	35
b.	Polar Cap Absorption (PCA) . . . . .	36
c.	Ionospheric Storms . . . . .	36
D.	THE EFFECTS OF POLAR REGION ANOMALIES . . . . .	38
1.	Auroral activity . . . . .	38
2.	Geomagnetic activity . . . . .	39
E.	THE EFFECTS OF NUCLEAR WAR . . . . .	40
1.	Radiation . . . . .	41
2.	Blast waves . . . . .	41
3.	Electro-magnetic pulse (EMP) . . . . .	42
F.	THE EFFECTS OF PEACETIME NATURAL DISASTERS . . . . .	43
IV.	INTEROPERABILITY/RECENT RESEARCH OF METEOR BURST . . . . .	44
A.	INTEROPERABILITY . . . . .	44

1.	CCITT X.25 Protocol . . . . .	44
2.	Proposed Federal Standards . . . . .	44
a.	Federal Standard 1055 (FS 1055) . . . . .	44
b.	Federal Standard 1056 (FS 1056) . . . . .	45
c.	Federal Standard 1057 (FS 1057) . . . . .	45
3.	MIL-STD-188-135 . . . . .	45
a.	Introduction . . . . .	45
b.	Required functional standards . . . . .	46
B.	RECENT RESEARCH ON METEOR BURST . . . . .	48
1.	Antenna design . . . . .	50
2.	Variable data rates . . . . .	50
3.	Modulation . . . . .	52
VI.	SUMMARY AND CONCLUSIONS . . . . .	53
A.	SUMMARY . . . . .	53
B.	CONCLUSIONS . . . . .	54
APPENDIX A	. . . . .	56
APPENDIX B	. . . . .	58
APPENDIX C	. . . . .	59
LIST OF REFERENCES	. . . . .	60
BIBLIOGRAPHY	. . . . .	63

INITIAL DISTRIBUTION LIST . . . . . 65



LIST OF TABLES

Table I. ANTENNA SUMMARY . . . . .	15
Table II. OPERATIONAL MODES . . . . .	26
Table III. GENERAL FUNCTIONS . . . . .	47
Table IV. INPUT/OUTPUT CONFIGURATIONS . . . . .	49

## LIST OF FIGURES

Figure 1.	Meteor Burst Overview . . . . .	4
Figure 2.	Trail densities . . . . .	5
Figure 3.	Diurnal Variation . . . . .	6
Figure 4.	Diurnal Cause . . . . .	7
Figure 5.	Seasonal Variation . . . . .	8
Figure 6.	Yagi-Uda Antenna . . . . .	11
Figure 7.	Antenna Radiation . . . . .	12
Figure 8.	Antenna Beam Width . . . . .	12
Figure 9.	Antenna size versus gain . . . . .	13
Figure 10.	Take-off Angle . . . . .	14
Figure 11.	Artificial Noise . . . . .	18
Figure 12.	Loss versus Range . . . . .	21
Figure 13.	Solar Features and Solar Wind . . . . .	32
Figure 14.	Ionospheric Layers . . . . .	33
Figure 15.	Solar Flare Activity . . . . .	36
Figure 16.	Auroral Zones . . . . .	39
Figure 17.	Variable data rates . . . . .	51
Figure 18.	Dynarate Computer Algorithm . . . . .	52

## I. INTRODUCTION

### A. PURPOSE

Meteor burst technology is now emerging from research and development into widespread applications throughout the world. It can benefit communication facilities in remote areas by providing a low power, long range communication capability; it can provide battle commanders with positioning data; it can advance sensor/data collection methods; it can provide survivable alternative mediums; and it can provide support throughout the Joint War Fighting Arena.

The intent of this thesis is to inform communication managers of the capabilities and limitations of meteor burst communication and to provide an understanding of how various operating conditions affect performance. Also, the thesis will present the advantages and disadvantages of meteor burst over other forms of communication.

### B. STRUCTURE

This thesis will afford an individual with no previous meteor burst communication experience a basic understanding of the phenomenon. Chapter II provides the background information and basic technical understanding of the system. Chapter III discusses the issues of survivability of meteor burst communication under the various adverse operating conditions.

Chapter IV discusses interoperability and the advances in meteor burst technology. The last chapter provides a summary of the paper's findings and conclusions.

## II. METEOR BURST OVERVIEW

### A. INTRODUCTION

Billions of dust-sized meteors enter our atmosphere each day. Meteor burst communication relies on the phenomenon of reflecting radio waves off the ionized trails left by these dust-sized meteors as they enter the atmosphere and disintegrate [Ref 1: p. 3].

The principles of operation are as follows: a master station transmits a continuous, coded signal, usually in the 40 to 50 MHz band [Ref 1: p. 3]. The coded signal is reflected off an ionized trail to a remote receiving station [Ref 1: p. 3].

The remote station decodes the signal, turns on its transmitter and reflects a signal back along the same path to the Master Station. Information can be sent in either direction until diffusion reduces the electron density of the meteor's trail to a value too low to sustain reflection. [Ref 1: p. 3]

Since the typical meteor trail has a useful duration of a few hundred milliseconds, the sensing of the meteor trail and sending of the message traffic is done in short bursts. Hence the name meteor burst communications.

## B. SYSTEM CHARACTERISTICS

Meteor burst communications (MBC) depends on the presence of meteors, their ionized trails and the density of the ionized trails. The meteor region occurs at altitudes of 85 to 120 kilometers. Radio line of sight (LOS) up and LOS down combine with the curvature of the Earth to limit single link ranges to approximately 2,000 km. [Ref 2: p. 4] Figure 1 illustrates this geometry [Ref 2: p. 5].

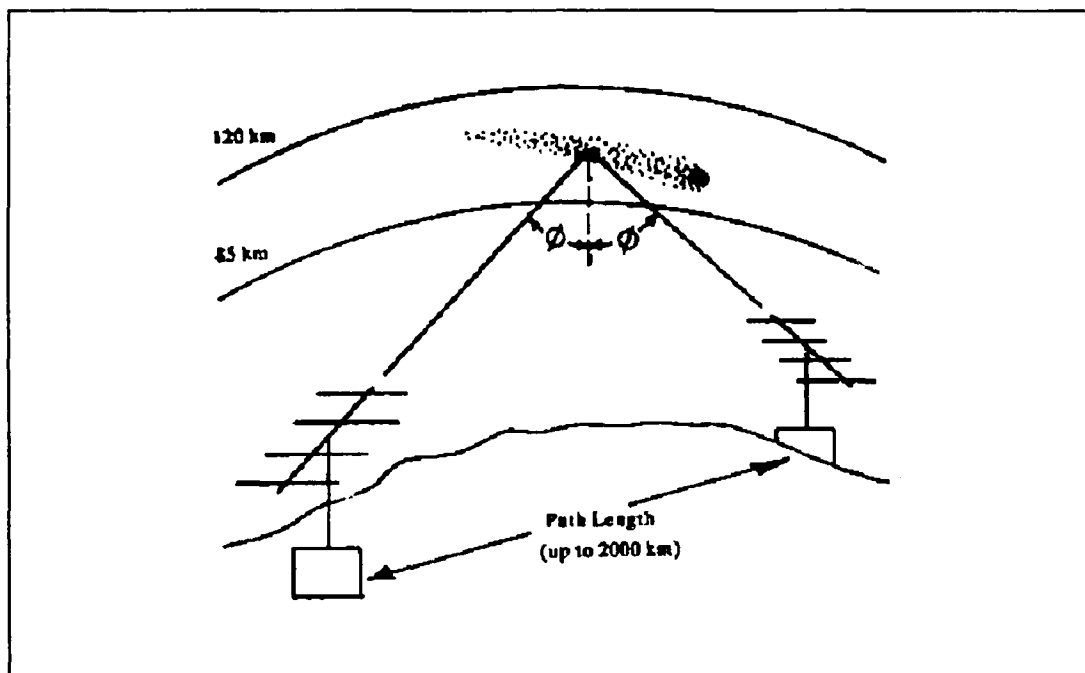

Figure 1. Meteor Burst Overview

We think of meteors as being very large, but in MBC this is not the case. MBC utilizes meteors as small as dust sized particles, on the order of  $1 \times 10^{-7}$  grams [Ref 2: p. 7]. It has been estimated that there are approximately  $1 \times 10^{12}$  meteors of

varying sizes entering our atmosphere daily. Every meteor has an ionized trail, but not every trail has the same density. A trail is classified as overdense if its electron line density is greater than  $1 \times 10^{14}$  electrons per meter or underdense if its electron line density is less than  $1 \times 10^{14}$  electrons per meter [Ref 2: p. 7]. While MBC can use either overdense or underdense trails, best communications are achieved with underdense trails (70% of meteor trails are of this type) [Ref 3: p. 660]. Figure 2 shows signal amplitude versus time for each type of meteor trail [Ref 2: p. 9].

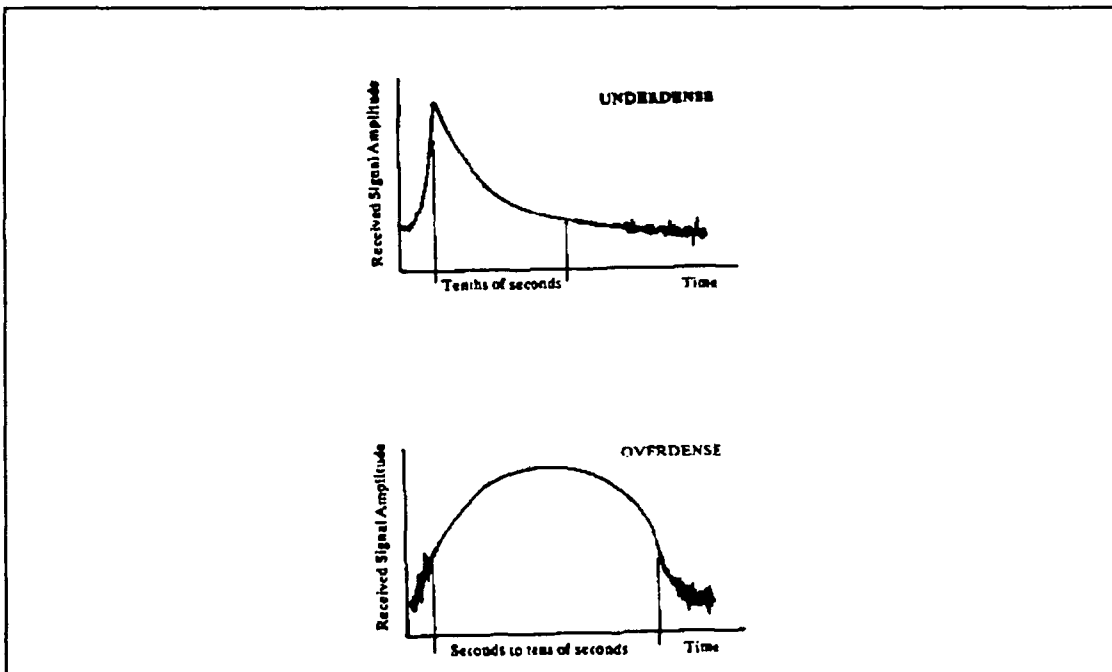

Figure 2. Trail densities

We have said that there are a great many of these meteors entering our atmosphere daily and it would seem that this

would provide a constant propagation mode, but in reality there are often short periods of time between suitable meteor trails. This time delay is referred to as wait time and can range from milliseconds to minutes depending on sun spot activity, system design parameters, and the availability of acceptable meteor trails which are themselves dependent upon diurnal and seasonal variations.

Figure 3 shows the diurnal variation of the meteor rate

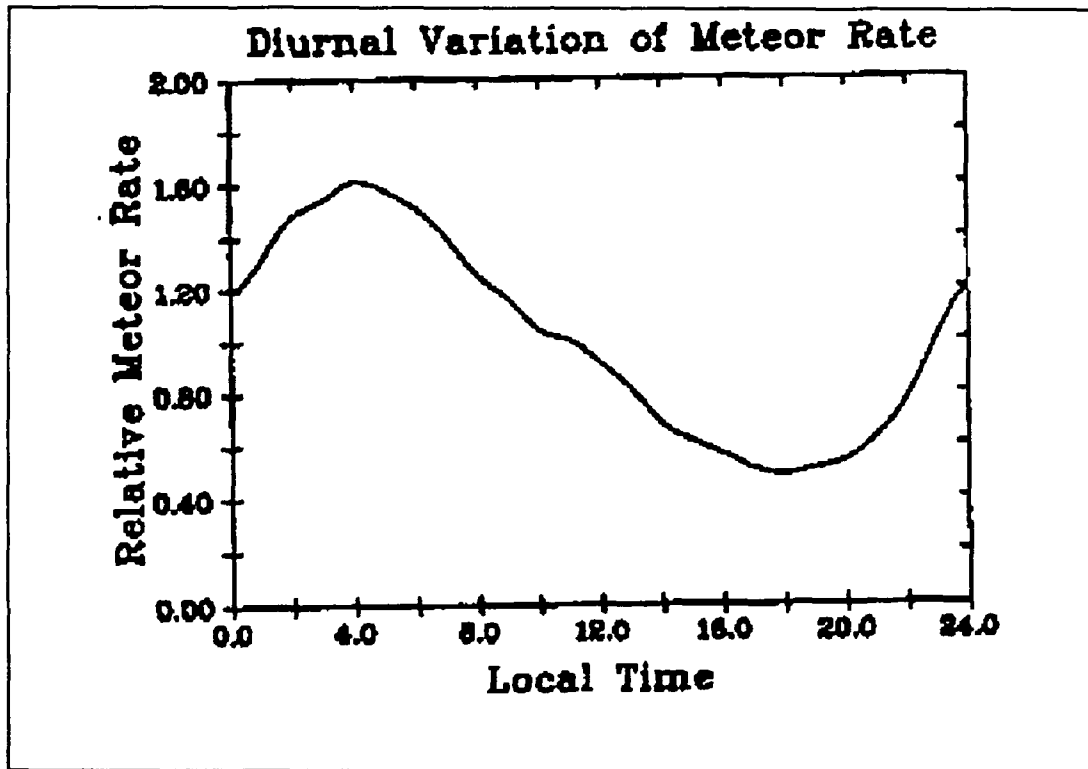

Figure 3. Diurnal Variation

[Ref 2: p. 12]. We see that the highest rate occurs in the early morning hours at approximately 0600 local and the lowest



rate occurs in the evening hours at about 1800 local [Ref 2: p. 11]. A brief pictorial explanation can be seen in Figure 4 [Ref 2: p. 12].

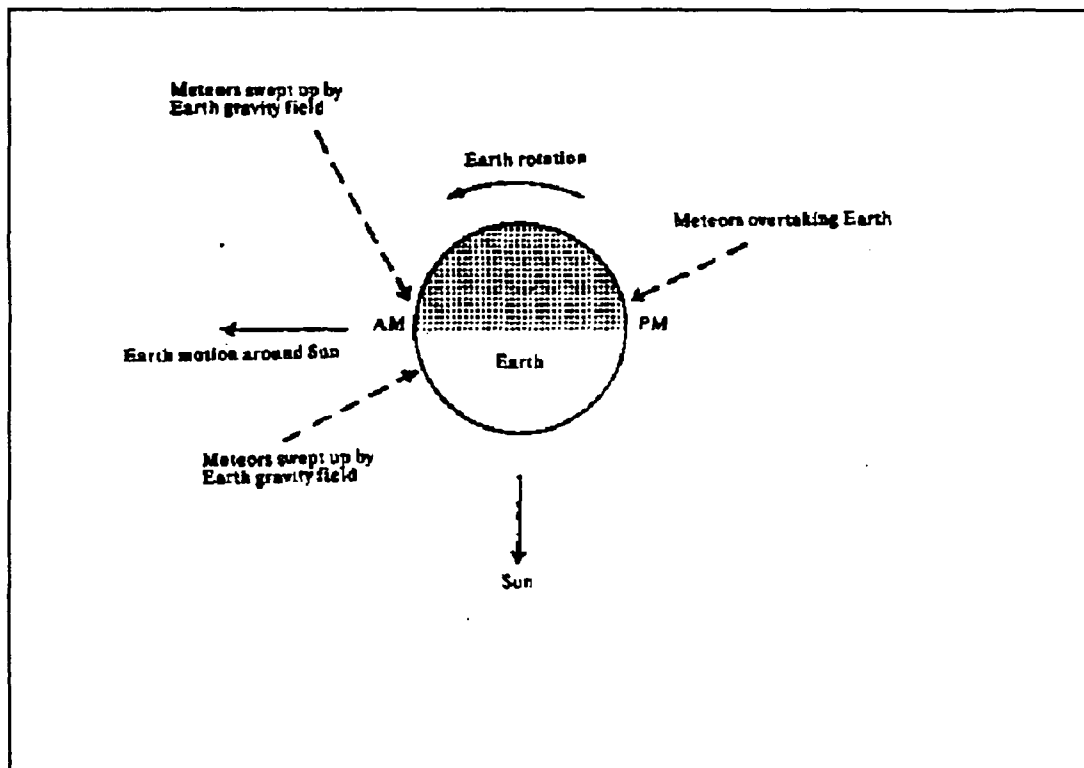

Figure 4. Diurnal Cause

Figure 5 shows the seasonal variation of the meteor rate [Ref 4: p. 1]. We see that the lowest seasonal rate occurs in the winter month of February, and the highest seasonal rate occurs in the summer month of July.

The seasonal variation in the meteor rate can be attributed to two factors. First, the distribution of sporadic meteors along the Earth's orbit is not uniform. The density is higher at those parts of the orbit corresponding to the seasonal peak activity in June, July, and August. [Ref 2: p. 10]

The second factor is the declination of the Earth's axis. The 22.5 degree tilt of the Earth's polar axis, which is the cause of the seasons in the hemispheres, also contributes to the seasonal variation in the meteor rates. [Ref 2: p. 10]

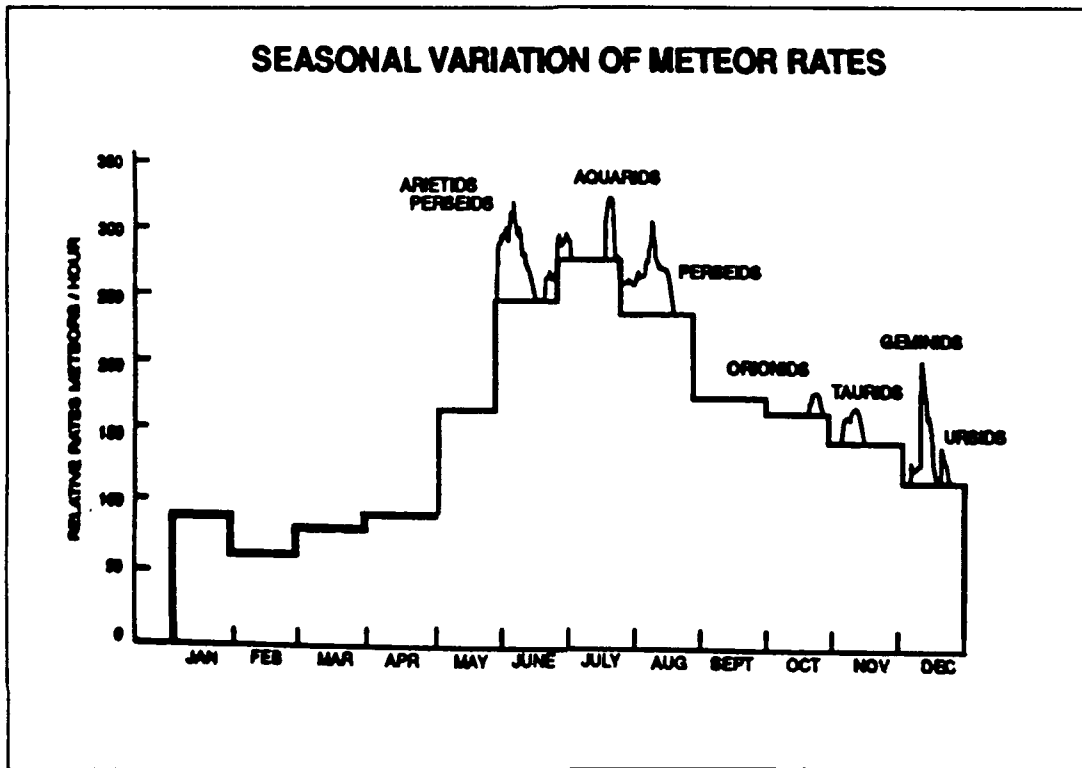

Figure 5. Seasonal Variation

The wait time required to transfer a message between two stations at a specified reliability determines the system performance. The primary system parameters that will influence this wait time are operating frequency, data rate, transmitter power, antenna design, and threshold level. [Ref 3: p. 666]

## **1. Operating Frequency**

Meteor burst communication operates in the VHF band of frequencies (30 to 300 MHz), but is limited to the effective frequency range between 30 to 50 MHz [Ref 2: p. 2]. The lower limit is determined by the desire to avoid ionospheric scatter and the effects of galactic and artificial noise which are predominant at the lower frequencies [Ref 2: p. 15].

The upper limit is determined by receiver sensitivity limitations, since received signal power at higher frequencies is weaker than at lower frequencies. This is in accordance with the relationship of frequency to signal strength which states that, for MBC, the amplitude of a signal is proportional to  $1/f^3$ . [Ref 5: p. 1591] Also, for MBC, the time duration of a signal is proportional to  $1/f^2$  which means that the wait time between messages increases as frequency increases [Ref 2: p. 13]. Also above 50 MHz, radio and television allocations in many countries preclude meteor burst operation [Ref 2: p. 15].

## **2. Data Rate**

Data rate is termed "throughput" in MBC. Due to the intermittent nature of the medium, throughput is measured as an average value of the entire transmission process. This is necessary because there are two distinct phases. Phase one involves the transmission of data when a suitable meteor trail

exists; phase two involves the wait time between meteors when no data is transmitted. [Ref 2: p. 14] This average throughput incorporates a myriad of factors to provide an important measure of system performance. Average throughputs of up to several hundred words per minute can be achieved with relatively simple equipment [Ref 1: p. 4].

### **3. Transmitter Power**

Transmitter power varies from equipment to equipment but an average value for master stations is 1 kw. The effect of transmitter power on wait time is inversely proportional: the higher the transmitter power, the shorter the wait time. [Ref 3: p. 667] Unfortunately, care must be taken to ensure that transmitter power is not so high that it blanks out a weak incoming signal. Also, it may be possible for noise sidebands on the transmitted signal to be stronger than the received signal. Filters of significant size are necessary in this type of situation. It may be better to operate at lower power levels so that filters can be incorporated in the same rack as the power amplifier. [Ref 2: p. 31]

### **4. Antenna Design**

A variety of antennas are suitable for use in meteor burst communication systems. For any given meteor burst system, certain antennas will have characteristics making them a better choice than others. The choice usually narrows down

to one or two possibilities, with the predominant type being Yagi-Uda. (Figure 6) [Ref 2:p. 62] The significant antenna characteristics that should be considered include directional pattern, gain, feedpoint impedance, polarization, and physical size. Only Yagi-Uda will be considered here since it is the predominant type.

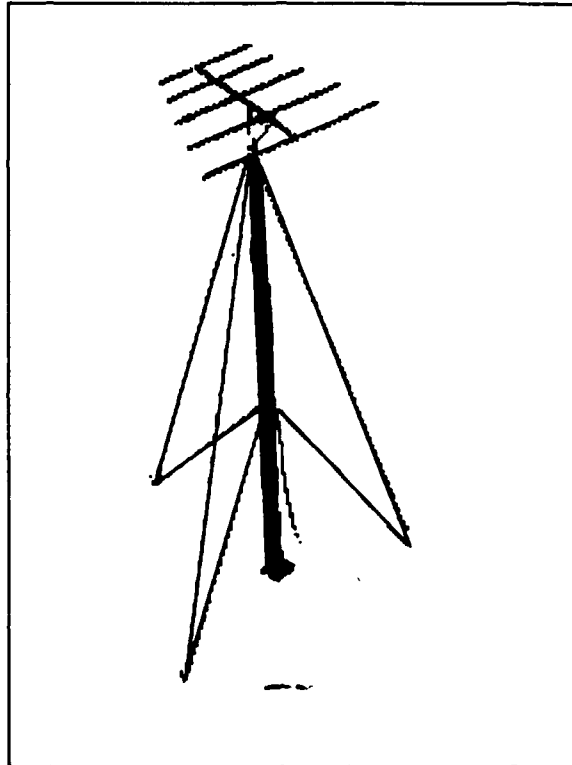

Figure 6. Yagi-Uda Antenna

The Yagi-Uda antenna is an array of dipoles arranged along a central supporting boom. One dipole is fed with power while the others are excited by mutual coupling. When the lengths and spacing are properly chosen, the radiation pattern of a Yagi will be essentially unidirectional, beaming radiated power in one preferred direction. [Ref 2:p. 62-63]

Figures 7 and 8 illustrate this point [Ref 2: p. 61] [Ref 8: p. 69].

The gain depends on the number of elements in the array. Meteor burst Yagis may have anywhere from 3 to 10 elements producing gains on the order of 7 to 15 db respectively. As more elements are used, the physical length of the boom increases, often imposing practical mechanical or space limitations on the obtainable gain. [Ref 2: p. 63]

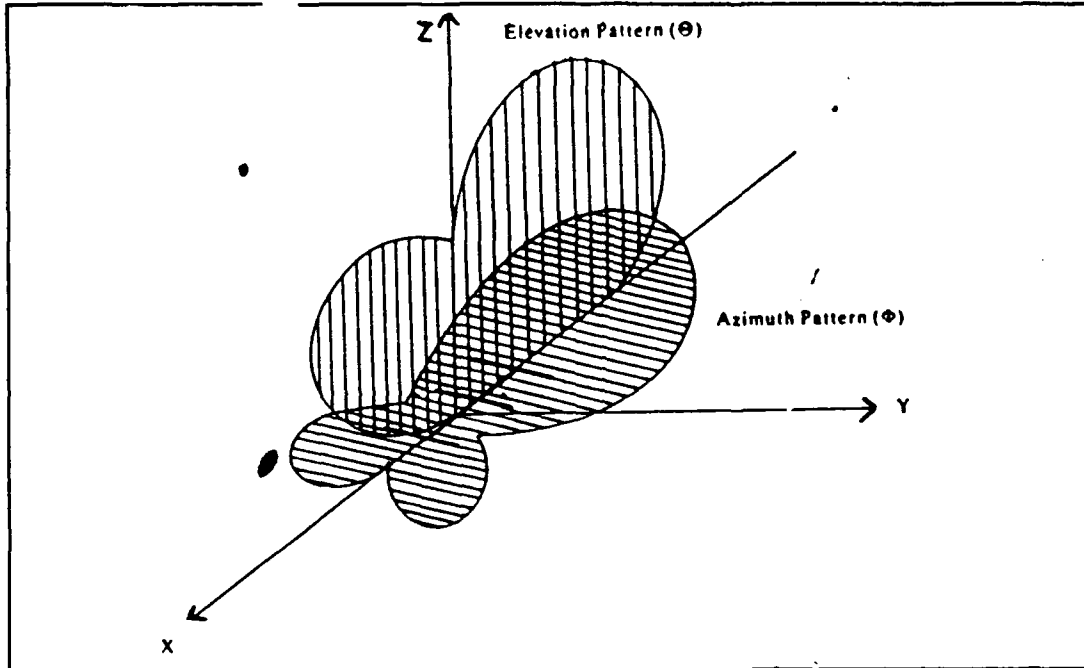

Figure 7. Antenna Radiation

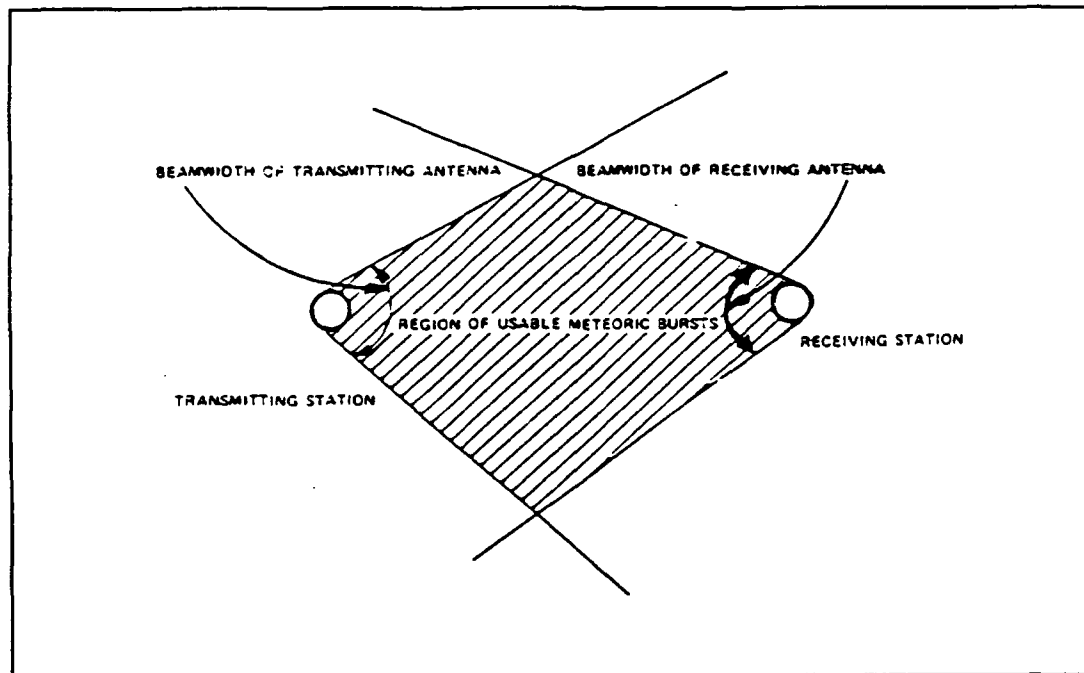

Figure 8. Antenna Beam Width

Figure 9 shows the relationship between the number of elements, length in wavelengths, and the obtainable gain of

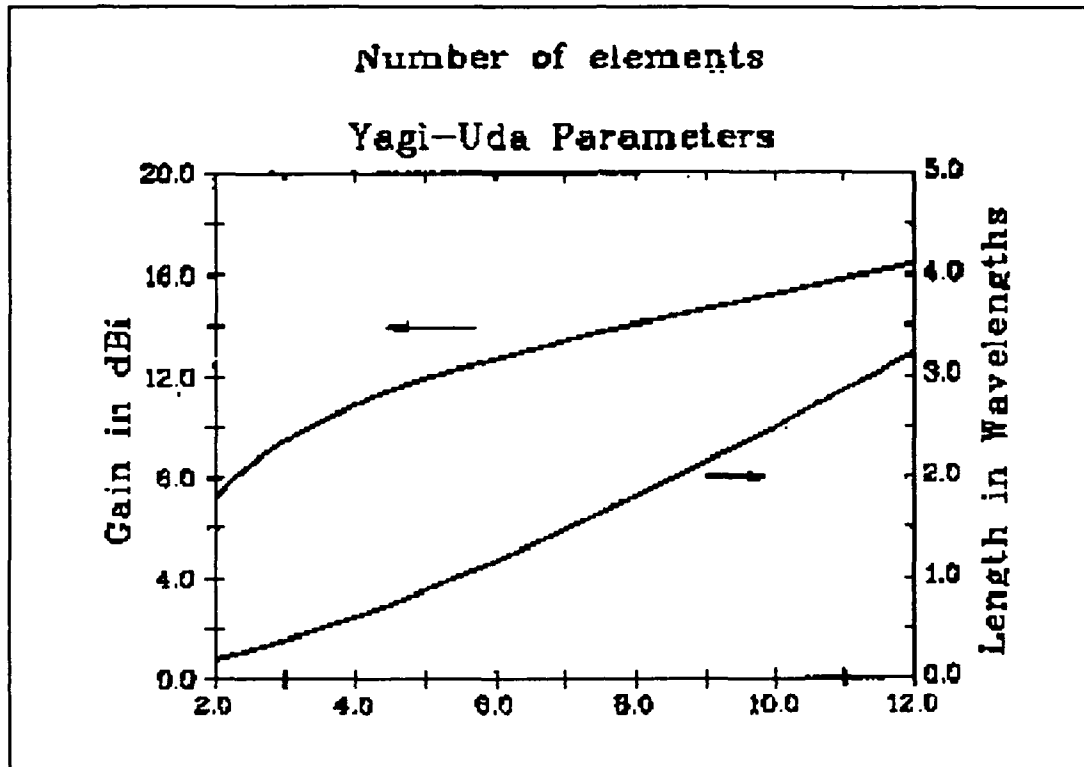

Figure 9. Antenna size versus gain

the antenna [Ref 2: p. 64].

Yagis are usually mounted with the plane of the antenna parallel to the surface of the earth, which results in horizontal polarization. However, the antenna can be rotated 90° in the elevation angle direction for vertical polarization. [Ref 2: p. 64]

Figure 10 shows optimum take-off angle for the Yagi antenna [Ref 2: p. 66], while Table I provides a summary of the various antenna types and their uses [Ref 2: p. 70].

## 5. Threshold Level

Threshold is a function of the type of modulation

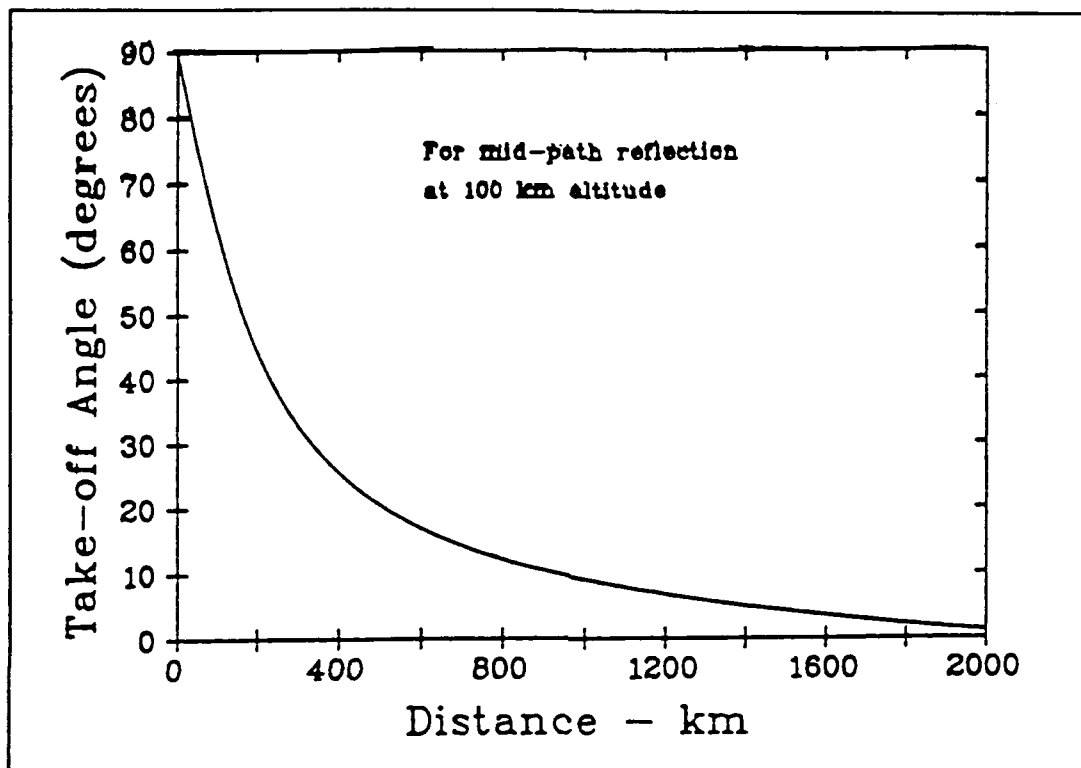

Figure 10. Take-off Angle

used, bandwidth, and the receiver noise. Meteor burst systems generally employ forms of PSK modulation. The primary advantage of PSK is a theoretical 3 db signal-to-noise ratio advantage over conventional FSK [Ref 3: p. 665]. This can be very significant in meteor burst where there is always a battle to obtain usable data from marginal threshold-level signals. Bit error rates (BER) of  $3 \times 10^{-4}$  or better are



## ANTENNA SUMMARY TABLE

- Use horizontally mounted (and polarized) Yagi antennas unless there are specific reasons for doing otherwise.
- For communication ranges less than 500 km, the possibility of tilting Yagi antennas for better high-angle radiation should be considered.
- For very short ranges an omnidirectional, horizontally polarized antenna mounted close to the ground to enhance high-angle radiation would be a first choice.
- If omnidirectional coverage is needed, a vertical dipole or ground plane antenna for vertical polarization or a turnstile antenna or full-wave loop for horizontal polarization should be used.
- For mobile use, the horizontally polarized halo or the vertically polarized vertical whip antenna are the obvious choices.
- If the central station in a network uses vertical polarization, all stations should use vertical polarization. If outlying stations communicate in only one geographic direction, system performance can be enhanced if they use directive beam antennas, such as Yagi.

normally desired [Ref 6: p. 2]. The lower the threshold level, the lower the wait time, and the greater the performance [Ref 3: p. 667-669].

## **C. EXTERNAL NOISE**

### **1. Galactic Noise**

Galactic noise is a function of frequency and can be calculated from the following formula [Ref 2: p. 41]:

$$N_g(\text{dbm}) = -124.5 - 22 \cdot \log(f_{\text{MHZ}}) + 10 \cdot \log(B_{\text{HZ}}) ,$$

where  $f$  is the frequency in Mhz and  $B$  is the bandwidth in Hz. This value is then compared with other noise power levels and the desired signal level to evaluate the system design. In a location free of artificial noise, galactic noise may be large enough to be the limiting factor in meteor burst reception. [Ref 2: p. 41-42]

### **2. Atmospheric Noise**

Atmospheric noise levels fall off very rapidly with increasing frequency and will not generally be significant above 30 MHZ and therefore will not enter into the link budget [Ref 3: p. 596]. If lower frequencies around 20 MHZ were desired for meteor burst then atmospheric noise might become a factor and would have to be taken into account.

### 3. Man-made(artificial) Noise

Artificial noise is the dominant noise source in meteor burst communication. This noise is a function of location and frequency which can be determined by the following formulas and are illustrated in Figure 11:

$$\begin{aligned} \text{Business : } N_B(\text{dbm}) &= -97.2 - 27.7 \cdot \log(f_{\text{MHZ}}) \\ &+ 10 \cdot \log(B_{\text{HZ}}) \end{aligned}$$

$$\begin{aligned} \text{Residential : } N_S(\text{dbm}) &= -101.5 - 27.7 \cdot \log(f_{\text{MHZ}}) \\ &+ 10 \cdot \log(B_{\text{HZ}}) \end{aligned}$$

$$\begin{aligned} \text{Rural: } N_R(\text{dbm}) &= -106.8 - 27.7 \cdot \log(f_{\text{MHZ}}) \\ &+ 10 \cdot \log(B_{\text{HZ}}) \quad [\text{Ref 2: p. 40}] \end{aligned}$$

It should be noted that these are median values used for the link budget, and consideration should be given to the variation of the noise levels about their median values when conducting in-depth analysis. If favorable results are obtained from the use of the median values, recalculation with more liberal noise estimates incorporating the variability should be made. [Ref 2: p. 45]

This variation is a measure of how much the noise level can be expected to deviate from the median value within any one-hour period. There is also a location variability which is a measure of how much the median noise level can be expected to vary from location to location within the same noise category. [Ref 2: p. 44]

Galactic, atmospheric, and man-made noise are all forms of broadband noise. Another external factor which should be taken into account when evaluating system design is

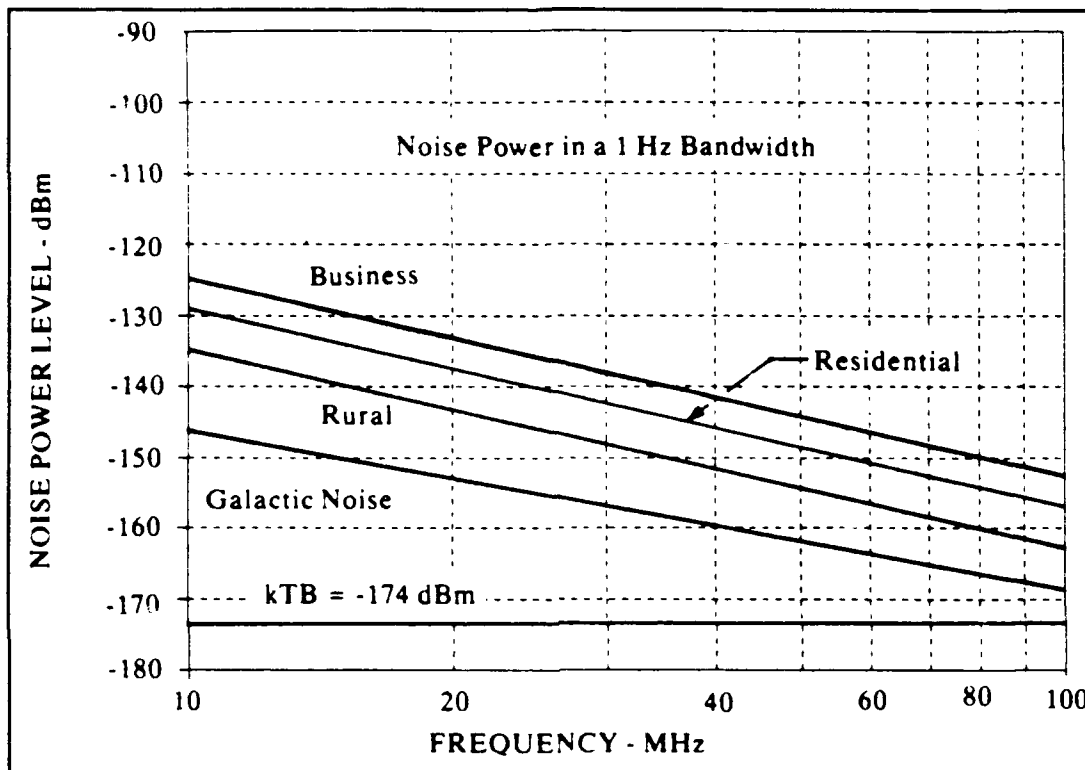

Figure 11. Artificial Noise

interference. Interference is a form of narrow band noise which comes from electronic devices operating in the same frequency range as the meteor burst system [Ref 2: p. 46]. There are four main causes of interference; the first is low-power communication devices such as cordless phones, child monitors, alarm systems, walkie-talkies, and remote control toys [Ref 2: p. 46].

The second source of noise is from two-way mobile radios. Even if there are no mobile radios with the same frequency in the immediate area of a meteor burst site, the RF ground wave of the mobile radio's signal may interfere at the meteor burst site [Ref 2: p. 47].

The third source of noise involves the second harmonic of an HF transmitter operating between 15 to 25 MHz and the third harmonic of an HF transmitter operating between 10 to 16.67 MHz. The nature of harmonic interference can be highly intermittent. [Ref 2: p. 48]

The fourth and final source of noise involves the use of personal computers (PCs). PCs constitute one of the single most predominant contributors to man-made noise. PCs are so noisy that the FCC must regulate their noise output. [Ref 2: p. 48] Class A devices which operate in the 30 to 88 MHz range can radiate interference levels up to 3000 microvolts per meter at a distance of 3 meters. [Ref 2: p. 48] This is highly significant when compared with the fact that usable burst signals are often at a level of less than 1 microvolt at the receiver. [Ref 2: p. 48] Based on field strength theory, this means that a class A device can produce a 1 microvolt per meter level of interference to a meteor burst receiver site at a distance of 9 km from the PC creating the interference! [Ref 2: p. 49-50]

#### **D. INTERNAL SYSTEM NOISE**

Equivalent input noise power is the value of input noise power that would produce the same receiver output noise power as the actual receiver in an ideal, noiseless receiver. The usefulness of equivalent input noise power of the receiver is that it can be directly compared to the levels of input noise power due to external sources and the input signal power. The goal, of course, is that the input signal power be greater than the largest of the various input noise power levels by an adequate margin. The equivalent input noise power for an ideal noiseless receiver with a 1 Hz bandwidth can be determined by:

$$N_i = k * T_o * B,$$

where  $k$  = Boltzman's constant,  $T_o = 290$  k, and  $B$  = bandwidth in Hz. [Ref 2: p. 51-53]

#### **E. TRANSMISSION LOSSES**

The last section that needs to be addressed is signal transmission loss, the sum of scatter loss and free-space path loss (FSPL). Figure 12 shows transmission loss versus range [Ref 3: p. 675].

##### **1. Scatter Loss**

Scatter loss is also referred to as additional path loss, and is the result of reflecting the signal off the

meteor trail. It involves several factors, but for our purposes, the details of reflection mechanisms are not important. To know that a reflection takes place and to be able to calculate the loss that the signal incurs in the process is sufficient. For a detailed analysis of this loss factor see Telecommunications Transmission Handbook, Chapter 9, by Freeman [Ref 3].

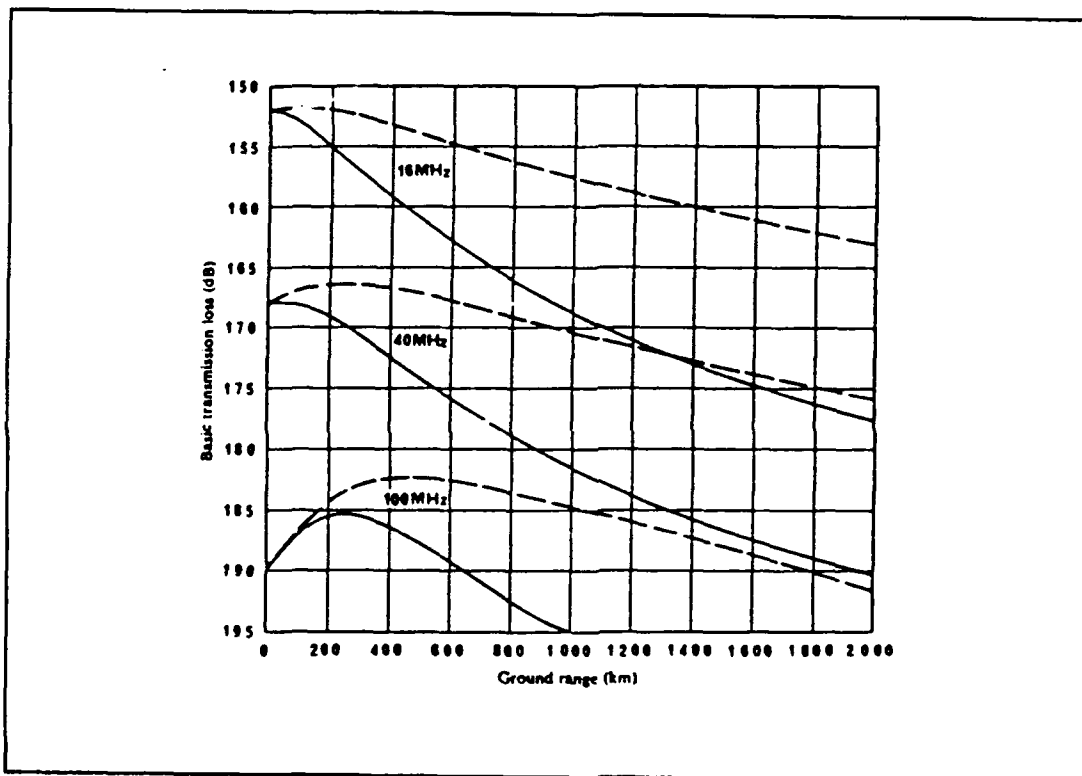

Figure 12. Loss versus Range

A highly condensed summary yields the following values: 51.4 db (average), 31.4 db (minimum) and 57.0 db (maximum) [Ref 2: p. 131]. These values assume a midpoint reflection from an underdense meteor trail and they also do

not take the time varying aspects of reflection into account. By adding the maximum value to the free-space path loss for a frequency of 40 MHz gives the curve for trails at right angles to the plane of propagation as seen in Figure 12 [Ref 3: p. 675].

## **2. Free-space path loss**

This is the signal loss associated with the signal's propagation through the atmosphere and is based on frequency and distance. It is given by the following formula:

$$L_p = 32.45 + 20 \cdot \log(f_{\text{MHz}}) + 20 \cdot \log(d_{\text{km}}) \quad [\text{Ref 3: p. 210-211}].$$

## **F. ADVANTAGES/DISADVANTAGES**

### **1. Advantages.**

- Signal path between transmitter and receiver is highly directional providing a small footprint. A small footprint decreases probability of intercept and unintentional interference and increases the jamming margin. [Ref 7: p. 125]
- Conservation of frequency spectrum is achieved since footprints of various users rarely overlap in space or time. This allows for multiple access via spatial and temporal diversity. [Ref 7: p. 125]
- Hardware requires smaller antennas and less complex equipment than traditional HF and is therefore reasonable in cost. Off-the-shelf VHF equipment can be used and highly directional antennas are unnecessary. [Ref 7: p. 132-134]



- Highly skilled operators are not needed and unmanned stations can readily be arranged for automatic operation in relay nets thus further reducing the cost of a system. [Ref 2: p. 4]
- High power is neither necessary nor economic--station equipment can be compact, mobile, and cost effective. [Ref 2: P. 29-37]
- Intrinsic degree of randomness makes MBC highly suitable for non-real time communications. [Ref 7: P. 126]
- Meteoric burst phenomena are fairly well understood and can be considered a consistently present act of nature. The medium is reasonably predictable and therefore considered stable. [Ref 8: P. 62]
- A meteor burst communication system transmits for only a fraction of a second. Because of that, it would be very difficult for an enemy to determine a transmitter location using direction finding techniques. [Ref 7: P. 126]
- The nuclear survivability of the meteor burst medium is superior to other media. Meteors will continue to enter our atmosphere regardless of nuclear blasts and they will produce usable trails. Additionally, because the transmit/receive equipment is small and requires only modest amounts of power, the equipment can be installed in hardened shelters easily. [Ref 2: p. 17-19]

## **2. Disadvantages**

- Low data rate is unsuitable for voice communications, and the intrinsic degree of randomness associated with the meteor trails makes MBC unsuitable for real time communications at this time. [Ref 2: p. 4]
- Reliance on meteors which are by nature sporadically timed and have trails of inconsistent density lends an element of uncertainty to meteor burst communications. Wait time is the most affected factor. [Ref 2: p. 4]
- MBC are sensitive to sun spots and, during increased solar activity, reliability may go down and wait time may go up. [Ref 9: p. 16]

## **G. APPLICATIONS**

Meteor burst communications is gaining acceptance worldwide as a viable means of data transmission. There are three general categories of application: long-haul communication, remote monitoring, and position monitoring.

### **1. Long-haul communication**

There are three modes of operation for data communications: point-to-point, network, and broadcast. To date most meteor burst systems have been designed for point-to-point applications. Point-to-point communication is a straightforward application. The only requisite for effective system control is the ability of the transmitting terminal to determine the beginning and end of a useful burst. If a transmission begins too late or ends too soon burst time will be wasted. If the transmission extends past the useful portion of the burst, a high error rate will result. Also in point-to-point, a feedback path is available. [Ref 5: P. 1593]

A network system is formed by connecting multiple master stations and remote stations together. One such network is the Western Union hardware currently installed for the Department of Agriculture. This system consists of 511 remote sites that communicate with two master stations. Another network system is the NORAD-SAC network that runs from Florida to Alaska. The network provides full duplex

communications with multiple point-to-point links of the NORAD-SAC network between various sites. Table II explains the modes of operation [Ref 2: p. 18]. It consists of eight master stations and 23 remote stations [Ref 10: P. 2].

Broadcast systems have received very little attention so far. For this method the broadcast transmitter must repeat the information enough times to ensure a high probability of reception by the remote stations. The simplest means of effecting a broadcast is to repeatedly transmit the messages that are brief enough to occupy a single burst of moderate duration. Each repetition of the message must be preceded by a preamble that will enable the remote terminal enough time to achieve synchronization. [Ref 5: P. 1593]

Some examples of systems currently in use are:

1) The Alaskan Air Command System uses thirteen 10 kw collocated terminals to provide a cost-effective backup to the primary satellite link that sends radar data to a regional operations center. The system also provides one-way synthesized voice communication to airborne interceptors. [Ref 2: p. 24]

2) The Chinese Communication Network is a system that provides communication from remote army camps to three different master stations. This system serves as the main communication link for low-priority record traffic. It employs 1 kw master

**Table II. OPERATIONAL MODES**

---

**OPERATING MODES**

**FULL DUPLEX**

Simultaneous transmit and receive on two separate frequencies.

**HALF DUPLEX**

Alternate transmit and receive on a two separate frequencies.

**SIMPLEX**

Alternate transmit and receive on a single frequency.

**FULL DUPLEX RELAY**

Simultaneous transmit and receive with station A and store data. Then, simultaneous transmit and receive with station B to forward stored data.

**BROADCAST**

Master continuously transmits on a single frequency. Remotes continuously listen on same frequency.

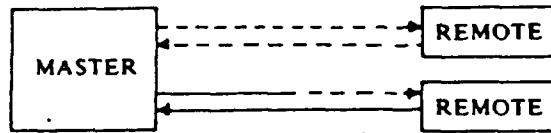

Communications is with one remote at a time. Remote unit is half-duplex.

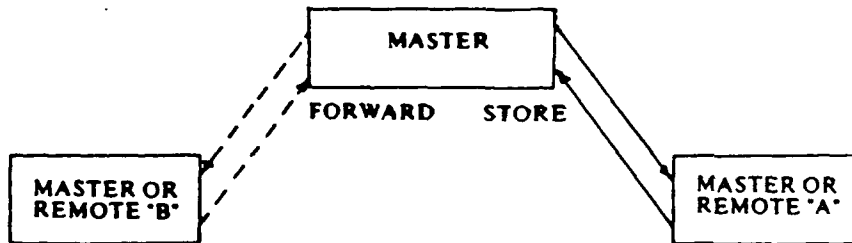

stations and 300 W remote stations. [Ref 2: p. 24]

3) The Alaskan Meteor Burst Communication System is a civil communication system operated for the joint use by the National Weather Service, Corps of Engineers, and Soil Conservation Service(SCS). The system provides for both communication assets and remote data acquisition.[Ref 2: p. 24]

## **2. Remote Monitoring**

Meteor burst is capable of employing various sensors at a remote station to monitor and collect environmental data. This data can then be stored for delayed transmission, if necessary, or directly transmitted back to a centrally located master station which will process the information. [Ref 2: p. 25]

Remote monitoring may be used for a variety of reasons, the most common of which is water management. The Soil Conservation Service's snowpack telemetry (SNOTEL) system makes use of this monitoring to aid in forecasting spring and summer water runoff, stream flows, etc. [Ref 2: p. 25] The system is capable of the following:

- Snowpack monitoring
- River level and rainfall monitoring

- Acid rain studies
- Air and water pollution monitoring
- Monitoring chlorine in water systems
- River quality monitoring

Other reasons for remote monitoring include threat warning [Ref 7: p. 131], pipeline management [Ref 11: p. 1-1], lighthouse monitoring [Ref 2: p. 25], alarm sensing [Ref 7: p. 132], and remote equipment activation [Ref 7: p. 132].

### **3. Position Monitoring**

This is one of the newest applications of meteor burst technology. The incorporation of a LORAN C navigation receiver and antenna into the meteor burst system provides for the tracking and up-to-the-minute positioning (accurate to within 500m) of long haul trucks, ships, and aircraft. [Ref 2: p. 26]

Two vehicle tracking systems that are currently in use are the LOAD-TRAK and the TRANS-TRAK systems being tested by North American Van Lines. [Ref 2: p. 26] Besides providing positioning data, the systems can also supply two-way message and facsimile transmission capability. [Ref 2: p. 27] This allows the parent company to efficiently inform drivers of updated itineraries and load changes.

The Navy is experimenting with position monitoring on various ship and aircraft platforms. It is even evaluating

meteor burst's potential for the tracking of buoys and icebergs [Ref 2: p. 25-27].

### III. SURVIVABILITY OF METEOR BURST COMMUNICATIONS

#### A. INTRODUCTION

Survivability is one of the most important factors in the design of military communication systems. Meteor burst communications systems are no exception. The issue of survivability involves both physical and functional survivability. Physical survivability, on one hand, very rarely provides sufficient protection to each element of a system to render the system survivable.

Functional survivability, on the other hand, addresses the set of sufficiently redundant subsystems so that the ability to communicate exists under adverse conditions. Thus, adequate survivability almost always demands a total systems approach regardless of the threat level. [Ref 12: p. 1441]

There are five sub-components of functional survivability:

- INTEROPERABILITY- the ability of systems, units, or forces to provide services to and accept services from other systems, units, of forces and to use the services so exchanged to operate effectively together. [Ref 13: p. 190]
  
- RELIABILITY- the ability of an item to perform a required function under stated conditions for a specified period of time. [Ref 13: p. 309]



- FLEXIBILITY- the ability to adapt to quickly changing environments and a wide range of operations.
  
- COMPATIBILITY- the capability of two or more items or components of equipment or material to exist or function in the same system or environment without mutual interference. [Ref 13: p. 82]
  
- RESPONSIVENESS- the ability to respond in an accurate and timely manner.

This chapter will illustrate the many aspects of survivability associated with the long-haul communications aspect of meteor burst communications as they pertain to certain adverse conditions. Interoperability will be discussed in Chapter IV. It should be noted that high frequency (HF) radio will be used as a comparative backdrop throughout the chapter.

#### **B. THE EFFECTS OF IONOSPHERIC DISTURBANCES**

On any given day, both the physical and functional aspects of survivability are tested under varying conditions. In Chapter II, some of the physical and functional aspects of survivability were already discussed. This sub-section will focus on the influence of solar activity on the communication mediums themselves.

Figure 13 [Ref 15: p. 258] depicts the solar features and the solar wind which affect communications. The sun is the major cause of variations in the propagation characteristics of the ionosphere, which vary with time of day. [Ref 16: p. 1]

During daylight hours, ultraviolet and x-rays of the sun ionize the Earth's atmosphere causing the formation of the D, E, and F1 layers of the ionosphere. Figure 14 illustrates the altitudes of these layers versus electron density. [Ref 17: p. 5]

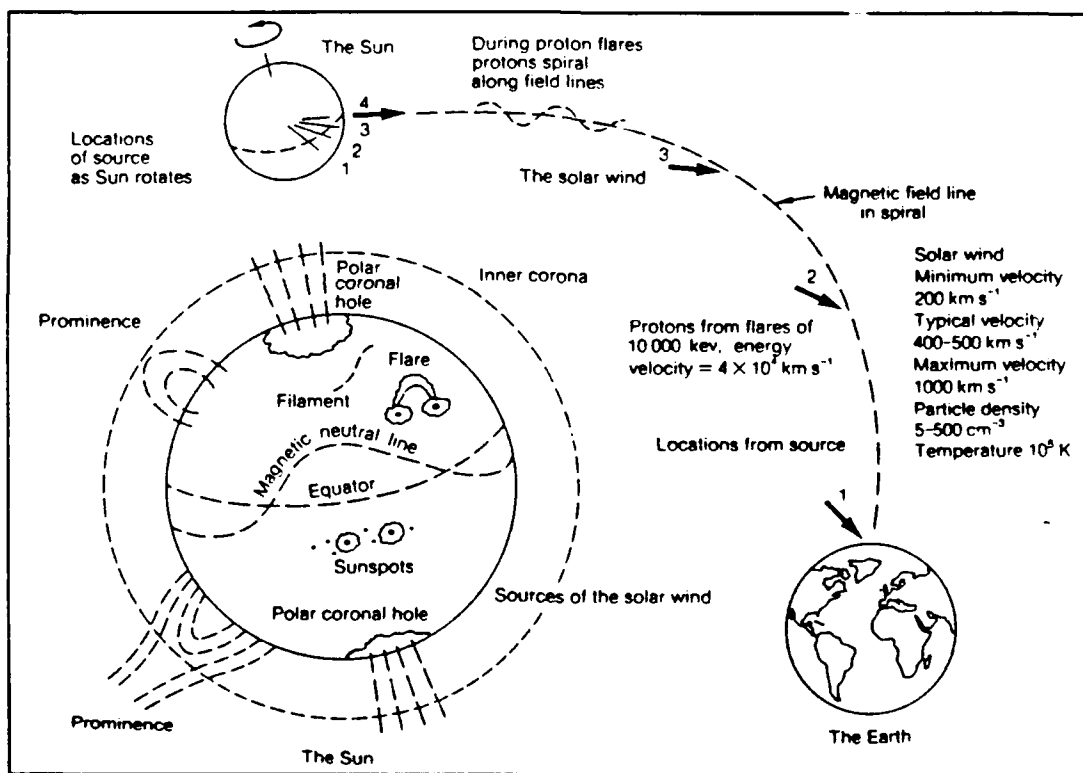

**Figure 13.** Solar Features and Solar Wind

According to Wells in *Proceedings Naval Review 1982*, "Due to the sun-shifting of the ionospheric layers in the upper

atmosphere, HF frequencies must be adjusted every few hours to achieve satisfactory communications." This is especially true around the hours of sunrise and sunset [Ref 16: p. 1].

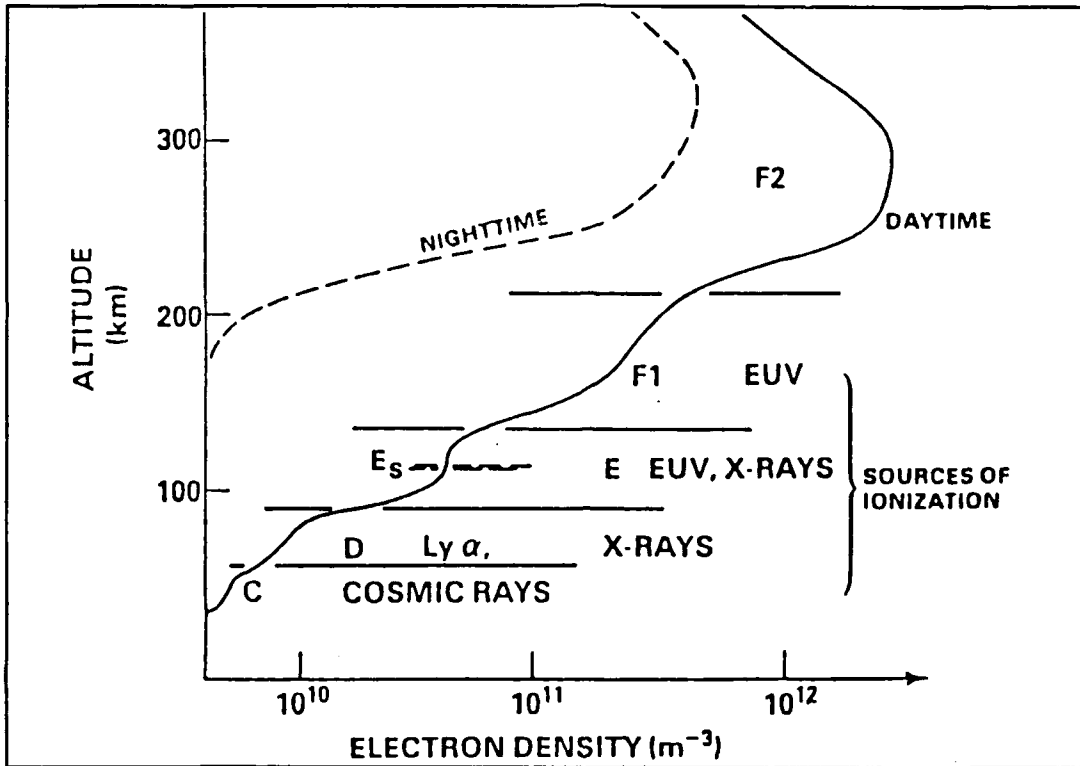

Figure 14. Ionospheric Layers

The MBC transmission path is unaffected by ionospheric disturbances which occur in the HF band for two reasons. First, MBC uses the ionization from meteor trails and not the ionized layers of the atmosphere. Therefore, temporal variations in layer heights do not impede the meteor burst propagation medium.

Second, adaptive data rate techniques may be used to adjust to the changing conditions. [Ref 14: p. 173]

In HF applications, transmissions are repeated, and frequencies are changed until a proper frequency channel is found. [Ref 14: p. 173]

Meteor burst communication, on the other hand, may use a technique called Dynarate to maintain performance and system reliability [Ref 14: p. 173].

Using a process called Dynarate, Meteor Communications Corporation (MCC) has increased throughput by dynamically varying the radio frequency (RF) data rate as a function of received signal strength. This process adapts to whatever condition is present at any time. Small signals are used at low data rates, thus minimizing wait times for short, high precedence messages while large signals are used at high data rates to maximize throughput. [Ref 14: p. 173-178]

### **C. THE EFFECTS OF EXTREME SOLAR ACTIVITY**

In the last section, the effects of "day-to-day" normal solar activity were discussed. This section will focus on the effects of extreme solar activity on communications systems. This activity comes in two forms: sun spots and solar flares.

#### **1. Sun spots**

A sun spot may be defined as:

A relatively dark region on the disk of the sun (photosphere), with an inner "umbra" of effective radiation temperature about 4500 K and an outer "penumbra" of somewhat higher temperature. [Ref 18: p. 274]

They appear as vortex-like disturbances moving across the face of the sun and are associated with the production of

large magnetic fields which have a direct impact on the ionosphere. [Ref 18: p. 274]

Sun spot activity reaches a maxima approximately every eleven years; overall sun spot activity is measured by the Wolf sunspot number [Ref 3: p. 134]. Since sun spot cycles are relatively predictable, degradation of communications can be expected at these times.

## **2. Solar flares**

A solar flare may be defined as:

An abrupt and totally unpredictable increase in the intensity of the electro-magnetic emissions near a sunspot region. It is seen as an increased area of brightness on the sun's chromosphere. [Ref 19: p. 1767]

Three different types of ionospheric disturbances result from solar flares: sudden ionospheric disturbances (SIDS), polar cap absorption (PCA), and ionospheric storms. These are illustrated in Figure 15 [Ref 17: p. 34].

### ***a. Sudden Ionospheric Disturbances (SIDs)***

SIDs occur almost immediately (within minutes) after the occurrence of a flare due to arrival of electromagnetic radiation, primarily in the form of x-rays. They affect the entire daylight portion of the earth and last as long as the flares. [Ref 17: p. 34-35]

### b. Polar Cap Absorption (PCA)

Around fifteen minutes after a flare, cosmic ray particles such as protons arrive at the Earth and continue from one to ten days, but normally last about three days. Complete communication blackouts can occur with no transmissions possible through the auroral regions (blackouts can occur elsewhere as well). PCAs normally last for around a day. Their occurrences are rare with only about seven or eight per year during sunspot maximum, and even fewer otherwise. [Ref 17: p. 34-35]

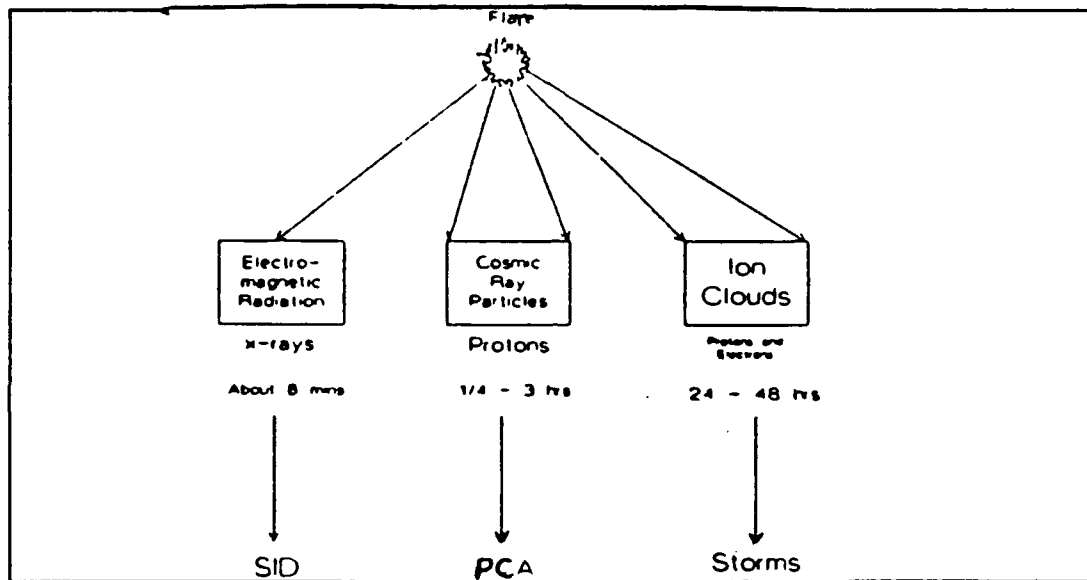

Figure 15. Solar Flare Activity

### c. Ionospheric Storms

The last arrivals from the flare are the plasma clouds. These clouds impinge upon the ionosphere creating "storms" with waves of increasing and decreasing electron density. They last for about 2-5 days and, as with the

other events, they enhance the D and F regions, increasing absorption. [Ref 17: p. 35]

The most observable effect of the ionospheric storms is the narrowing, or total elimination, of the available HF transmission frequencies as a result of the increased D layer absorption. This creates a lowering of the maximum useable frequency (MUF) and the simultaneous raising of the lowest useable frequency (LUF). [Ref 17: p. 35]

The effects on meteor burst are different from those on the HF spectrum. At the onset of solar activity, receivers detect increased noise levels just as HF does. The difference comes during the PCA and ionospheric storms. MBC performance is usually affected three days after solar activity begins which coincides with the time frame of the ionospheric storm's effects [Ref 20: p. 10]. While HF is severely, if not totally, disrupted, meteor burst still continues to operate but at a slower rate [Ref 20: p.10-11].

During the March 1989 solar activity, the SNOTEL system in the western United States observed an increase in average system response time and three days later, a slight decrease in systemwide performance, from 90% down to around 78% [Ref 20: p. 11].

#### **D. THE EFFECTS OF POLAR REGION ANOMALIES**

The polar regions have long since been a great hinderance to communications. Besides the disturbances caused by the severe weather patterns, strong magnetic fields and disrupted zones of the ionosphere caused by auroral activity create havoc throughout the traditional communications spectrum (HF).

##### **1. Auroral activity**

Aurora activity may be defined as:

A luminous phenomenon caused by electrical discharges in the atmosphere; probably confined to the tenuous air of high altitudes. It is most commonly seen in sub-arctic and sub-antarctic latitudes and is called aurora borealis or aurora austrailis respectively, according to the hemisphere in which it occurs. [Ref 20: p. G-2]

The extent of the aurora zones can be seen in Figure 6 [Ref 15: p. 254]. It should be noted that during times of extreme solar activity, auroral zones can be extended greatly. Auroras have been known to occur as far south as Florida.

The aurora can blot out HF radio communications in much the same manner as solar activity does, but on the other hand, it can also be used to increase the transmission path for VHF radio [Ref 15: p. 260]. Meteor burst transmits in the VHF range, which normally involves a line of sight (LOS) propagation path. However, when a VHF signal encounters the large number of electrical particles in the magnetic fields of



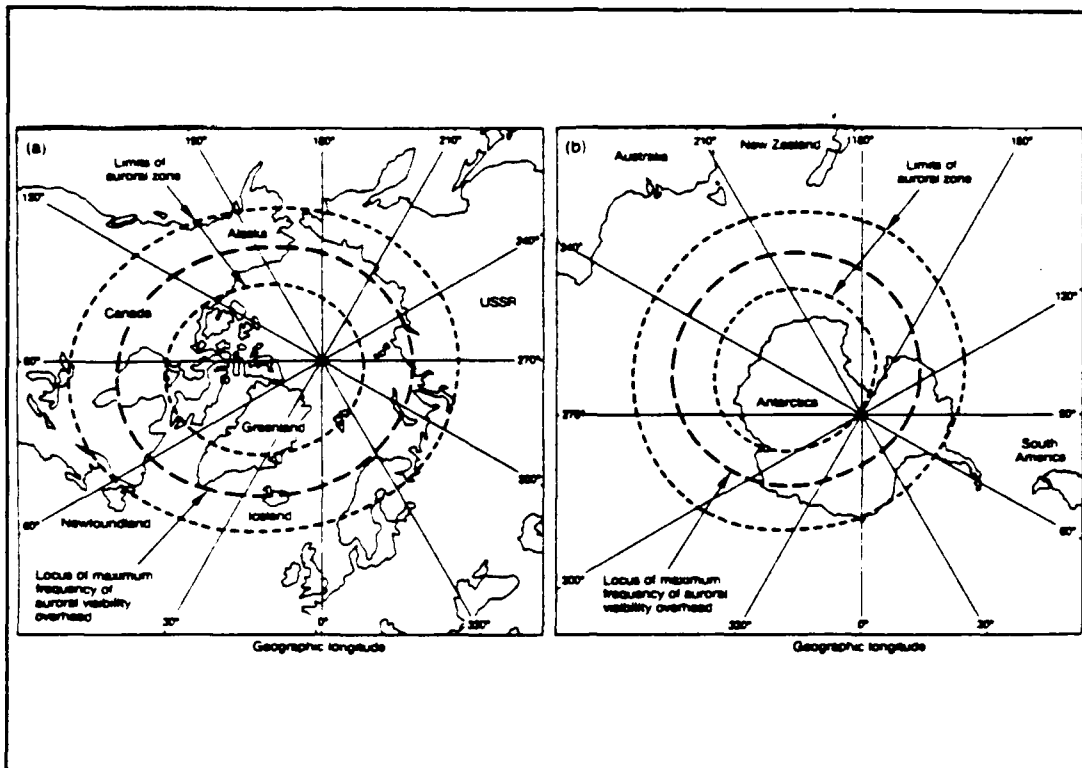

Figure 16. Auroral Zones

the aurora, ionospheric scattering occurs. This allows for line of sight (LOS) ranges to be extended beyond the normal radio horizon. [Ref 16: p. 20]

## 2. Geomagnetic activity

In addition to the auroral activity, geomagnetic activity is also the result of solar activity on the polar regions. Geomagnetic activity is an increase of electrical ground potential as a result of electron bombardment, driven by the solar winds, on the Earth's magnetic fields.

Ground potentials can induce loads in electrical transmission lines and currents in long distance conduits such as the Alaskan oil pipeline [Ref 15: p. 260]. These potentials can cause widespread power losses as a result of excessive electrical currents being injected into power lines. This occurred in Canada in March of 1989, and in New York in 1969 and 1972 [Ref 15: p. 260].

#### **E. THE EFFECTS OF NUCLEAR WAR**

A nuclear detonation can disrupt the ionosphere for hours or days, and interrupt long range HF radio communications. [Ref 8: p. 62] Certain high-priority communications are needed immediately following nuclear attack. These include:

- Maintenance of the strategic retaliatory capability of the United States. [Ref 8: p. 61]
- Control of continuing military operations both within and outside of the continental United States. [Ref 8: p. 61]
- Continuation of diplomatic relations with allies and neutrals plus possible negotiations with the enemy. [Ref 8: p. 61]
- Actions to ensure the continuity of federal, state, and local governments. [Ref 8: p. 61]
- Provision of civil defense, including the collection and disseminating of radioactive fallout data. [Ref 8: p. 61]
- Coordination of relief operations. [Ref 8: p. 61]

These objectives are not likely to be realized following a nuclear attack if reliance is placed on radio links making use of the ionosphere; i.e., high frequency (HF) [Ref 8: p. 61]. Meteor burst communication uses an alternative medium and is expected to continue to provide the needed connectivity.

### **1. Radiation**

Nuclear radiation is primarily a physical hazard to personnel rather than equipment, but contaminated equipment cannot be used. Meteor burst systems are fully automated, and can be deployed rapidly. The use of remote keying and a three-day message storage capacity [Ref 20: p. 7] eliminate the need for exposing personnel to the harmful radiation.

### **2. Blast waves**

Blast waves from a nuclear detonation threatens the physical survivability of equipment. A blast wave may be defined as:

A pulse of air, propagated from an explosion, in which the pressure increases sharply at the front of a moving air mass, accompanied by strong, transient winds and thermal radiation. [Ref 22: p. 6]

While traditional HF antennas must be exposed to these waves, and are therefore susceptible to destruction [Ref 23: p. 55], meteor burst antennas can be made blast resistant. This is achieved by the use of buried antennas.

The term "buried" is misleading, because typically buried antennas are not covered with earth, as the name implies.

Although located below the surface, they are exposed to the extent that they can "see" the sky area that they must illuminate. A radome, transparent to the frequencies employed, may be used to afford protection while not interfering with operation. [Ref 2: p. 68]

### **3. Electro-magnetic pulse (EMP)**

The greatest threat to communications from nuclear war comes from the electro-magnetic energy pulse that is discharged from a nuclear explosion.

After detonation, large portions of the ionosphere may be totally destroyed or severely damaged. It is this ionospheric disruption which interrupts high frequency (HF) communications relying on the ionosphere. [Ref 8: p. 62]

Meteor burst communication, on the other hand, does not rely on the use of the ionosphere, but rather utilizes the temporary ionization produced by meteor trails. While the ionosphere may be destroyed, meteor trails will continue to provide sufficient ionization for communication via meteor burst. Therefore, "MBC recovers from the atmospheric nuclear events more quickly than high frequency (HF). MBC involves higher frequencies (VHF) that, not affected by ionospheric disturbances, will be considerably less attenuated." [Ref 24: p. 56]

Another aspect of survivability is the process of radiation hardening which "improves the ability of a device,

piece of equipment, or transmission link to withstand nuclear or other harmful radiation [Ref 19: p. 1549]."

#### **F. THE EFFECTS OF PEACETIME NATURAL DISASTERS**

Emergency situations require that survivable communications be provided and that connectivity with both civil and government authorities be maintained.

Natural disasters such as flood, fire, and earthquake each present their own special difficulties when it comes to establishing and maintaining a communications link.

Guided media communications such as telephone, cable, and computer data networks, may be disabled as a result of severed power or data lines, destroyed transmission facilities, or incapacitated personnel.

Unguided media communications such as radio prove more useful. Meteor burst communication equipment is designed to operate under extreme environmental conditions. Portable systems can be set up quickly, powered by solar cells and, when combined with LORAN C, provide position monitoring [Ref 2: p. 29-35].

#### **IV. INTEROPERABILITY/RECENT RESEARCH OF METEOR BURST**

##### **A. INTEROPERABILITY**

This section is intended to provide a basic understanding of the parameters required to achieve interoperability of meteor burst communication equipment with other communication systems and equipment.

###### **1. CCITT X.25 Protocol**

The Comité Consultatif International de Téléphone et Télégraph (CCITT) X series is concerned with data communication networks, specifically the services, facilities and interfaces that relate to wire communications [Ref 3: p. 627-630].

Because the meteor burst transmission path differs significantly from the continuous paths typical of land-line or satellite communications, and each equipment manufacturer has its own special requirements, changes are needed to the X.25 protocol for it to incorporate meteor burst communication. [Ref 2: p. 101]

###### **2. Proposed Federal Standards**

###### **a. Federal Standard 1055 (FS 1055)**

FS 1055, "Telecommunications: Interoperability Requirements for Meteor Burst Radio Communications Between Conventional Master And Remote Stations," facilitates

interoperability between Federal Government Meteor Burst Communication (MBC) master and remote stations used in radio telecommunications applications [Ref 25: p. 1].

**b. Federal Standard 1056 (FS 1056)**

FS 1056, "Telecommunications: Interoperability Requirements For The Encryption Of Meteor Burst Radio Communications," facilitates interoperability between meteor burst radio communication facilities and systems of the Federal Government [Ref 26: p. 1].

**c. Federal Standard 1057 (FS 1057)**

FS 1057, "Telecommunications: Interoperability Requirements For Meteor Burst Radio Communications Between Networks By Conventional Master Stations," facilitates interoperability between Federal Government Meteor Burst Communication (MBC) internetwork gateway master stations used in radio telecommunication applications [Ref 27: p. 1].

**3. MIL-STD-188-135**

**a. Introduction**

This document, "Interoperability and Performance Standards For Meteor Burst Communications, Initial Capability," provides initial capability standards for tactical and long-haul equipment associated exclusively with meteor burst communications [Ref 6: p. 1].

***b. Required functional standards***

According to section 4.2 of the document, "The fulfillment of nine general functions shall be required to achieve MBC system interoperability." Each of these are outlined below and shown in Table III [Ref 6: p. 7] as they relate to their respective equipment components.

- ANTENNA POLARIZATION. The transmitted signal shall be linearly polarized. A horizontally oriented E-field should be used. Most efficient transmission is obtained by use of horizontal polarization. However, where there are special constraints vertical polarization may be used, at some loss of efficiency. Note that the polarization used at any particular terminal must be the same as that of the terminal with which the terminal is to communicate. [Ref 6: p. 8]
- OPERATING RADIO FREQUENCY. The equipment shall have an operating frequency range of 30.000 Mhz to 88.000 Mhz or 30.000 Mhz to 54.000 MHz. The preferred frequency range is 30.000 MHz to 54.000 MHz. [Ref 6: p. 8]
- MODULATION. Differentially Encoded Binary Phase Shift Keying (DEBPSK), with phase deviations of +90 and -90, and nonreturn-to-zero (NRZ) keying shall be the required modulation. Coherent detection shall be provided at the receiver. [Ref 6: p. 8-9]
- BIT PROCESSING. The equipment shall be capable of operating at 2, 4, and 8 kbps for communication systems and at 8 kbps for remote sensing systems. Synchronization will be achieved using link protocols. [Ref 6: p. 9]
- ERROR CONTROL. Communication systems shall incorporate "Go-Back-N" Automatic Repeat Request (ARQ) technique, where all retransmissions are sent in succession. The system shall operate using a negative acknowledgement (NAK) scheme and ANSI 16 Cyclic Redundancy Check (CRC) code for error detection. [Ref 6: p. 9]



Table III. GENERAL FUNCTIONS

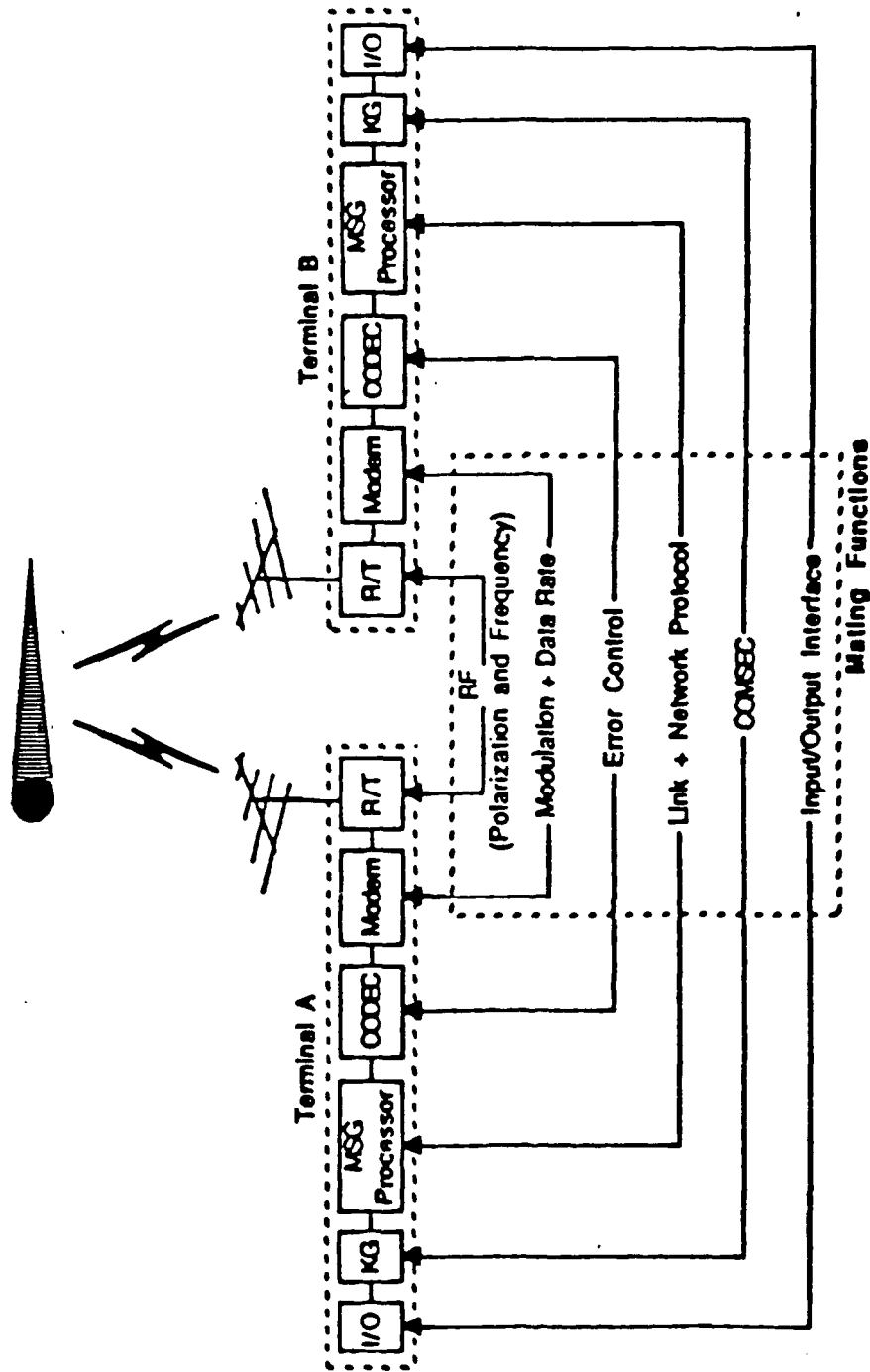

- LINK PROTOCOLS. The common mode link protocol shall support communications and remote sensing systems, accommodate a multinode network, and operate in half-duplex, full-duplex, broadcast, and polling modes. The equipment shall have the capability to handle three types of messages: point-to-point which contain no routing information, network messages which contain routing information, and broadcast messages which are messages sent from the master intended for a number of recipients but with no acknowledgement. [Ref 6: p. 10]
- NETWORK PROTOCOLS. The network protocols are designed to support the transmission of messages within a single star network (one master serving up to 254 remotes) or a linked star network (using master-to-master trunking). [Ref 6: p. 31]
- COMSEC. Communications systems shall incorporate COMSEC to provide end-to-end encryption. This does not apply to remote sensing systems. The COMSEC device shall encrypt the entire message before transmission. [Ref 6: p. 34]
- INPUT/OUTPUT INTERFACES. Communications interface ports shall be provided on MBC terminals to support two-way message traffic between the MBC terminal and the Keyboard Send/Receive (KSR) terminal of host processors. The data rates at the interface shall be 300 and 1200 baud using the ASCII seven bit character plus one parity bit. [Ref 6: p. 36] Table IV illustrates the input/output configuration. [Ref 6: p. 38]

## **B. RECENT RESEARCH ON METEOR BURST**

As we have seen from Chapter II, meteor burst communication has limitations concerning throughput and noise. This chapter will discuss some of the efforts currently being studied to eliminate these limitations. Research is being conducted in the areas of antenna design, variable data rates, and new modulation schemes.

**Table IV. INPUT/OUTPUT CONFIGURATIONS**

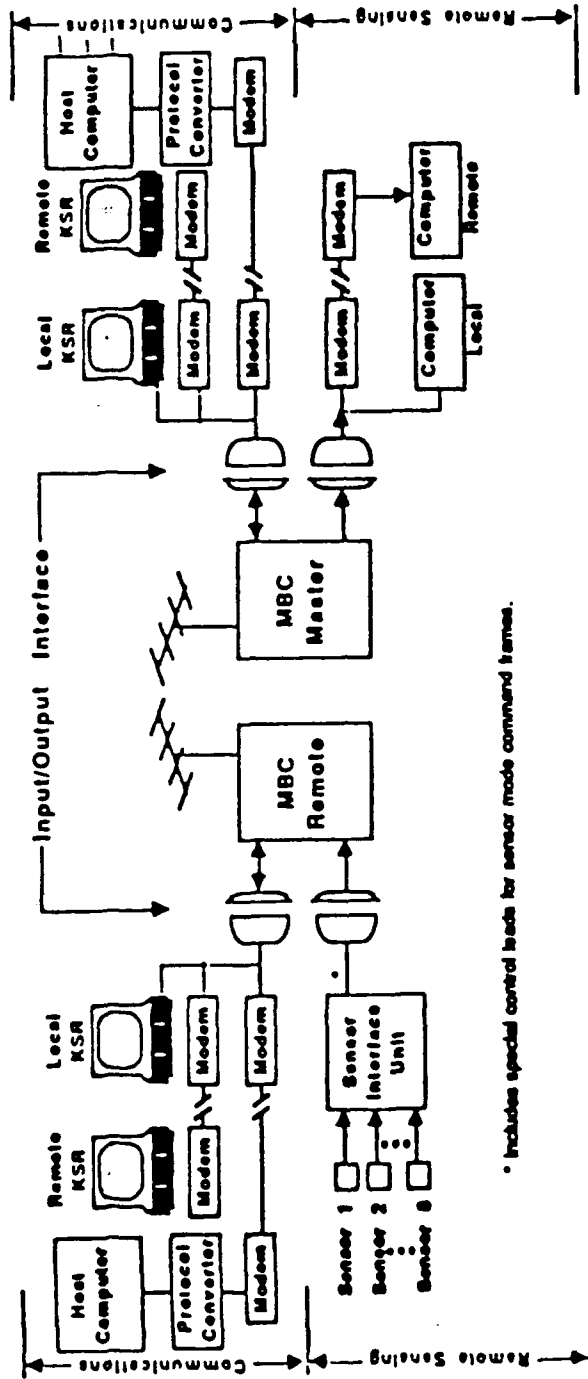

• Includes special control leads for sensor mode command frames.

## **1. Antenna design**

The design enhancement of antennas for meteor burst communications is one of the most significant factors in improving the link margin. Not only can throughput be increased, but man-made noise can also be reduced at the same time by using "smart" antennas, currently being tested. [Ref 28]

"Smart" antennas will provide null steering towards areas of high noise to reduce the man-made noise level while still maintaining the desired directivity and tracking capability of a desired meteor trail. [Ref 28] A region of high concentration of meteors in the atmosphere is called a "hot spot". In these areas there will be a greater number of meteor trails to utilize which allows burst transmission rates to approach a state of near-continuous data transmission. [Ref 28]

## **2. Variable data rates**

Variable data rates involves the sending of data at higher rates when the received signal strength is strong and slowing the data rate as the signal strength decreases to increase throughput efficiency [Ref 14: p. 177].

Meteor Communications Corporation (MCC) developed a technique called "DYNARATE" in the 1980s to improve throughput via variable data rates [Ref 14: p. 173].

Figure 17 [Ref 14: p. 177] shows the results of this technique on a large, underdense meteor signal while Figure 18 [Ref 14: p. 178] presents the relationship between available signal-to-noise ratio and transmission data rate.

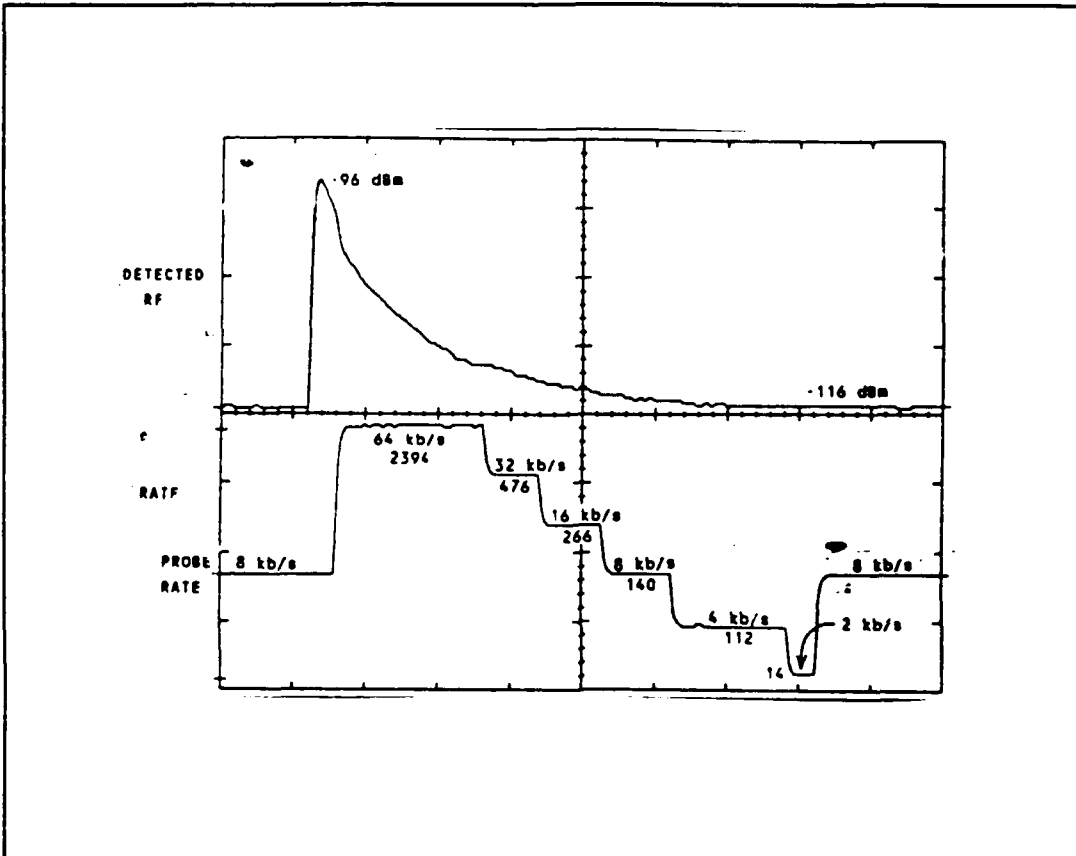

Figure 17. Variable data rates

Currently MCC is working on modifications to this technique to enhance throughput capability for purposes such as the continuous transmission of linear encoded voice signals, which up to now have been a major limitation of meteor burst communication. [Ref 28]

### 3. Modulation

MCC is also working on methods of increasing throughput by the use of advanced modulation schemes which

$E_b/N_0$	Action
>18	Increase data rate 4X
16-18	Increase data rate 2X
13-15	No change
10-12	Decrease data rate by 1/2
<10	Decrease data rate by 1/4

Figure 18. Dynarate Computer Algorithm

will enhance the variable data rate technique mentioned above. MCC hopes to test a "high performance throughput system" in June of 1992 based on not only the advanced modulation, but also increased power output, advanced antenna design and variable data rate. Throughput rates from this test are expected to be in the Kbps range. [Ref 29]

## VI. SUMMARY AND CONCLUSIONS

### A. SUMMARY

Chapter II began with an overview of meteor burst communication, including the operating characteristics, noise factors, and transmission losses affecting this unique communication link. Next it presented the advantages and disadvantages of meteor burst communication; the primary advantage is that meteor burst does not use the ionosphere for the propagation of radio waves, the primary disadvantage is the limitation of throughput for voice communication. Then, the three areas of application-- long-range communication, remote monitoring, and position monitoring-- were described.

Chapter III presented the issues of meteor burst survivability under various adverse conditions, as compared to traditional long range high frequency (HF) communication. Meteor burst is not affected as severely by ionospheric disturbances as HF, can be continually operated under extreme physical conditions, and has an almost continuous propagation medium.

In Chapter IV, the design criteria for the interoperability of meteor burst equipment were presented,

along with highlights of some of the current technological trends to improve performance. Meteor burst equipment is being designed to be compatible and interoperable with many communication systems and is in accordance with the Copernicus architectural guidelines that the Navy is implementing. Trends to improve performance include the use of adaptive data rates, attempts to reduce artificial noise, the development of improved modulation techniques, and the design of "smart" antennas.

## **B. CONCLUSIONS**

Meteor burst communication is feasible, economical, and highly survivable under many adverse conditions in both peacetime and war. There are many applications of the technology which are currently being used throughout the world. As the frequency spectrum becomes more and more restricted, it will be important to be able to send information on a narrow band in a microburst.

Currently, meteor burst is delegated to secondary roles such as remote sensing, backup data transfer systems, and low-priority communication nets for remote encampments. Applied research strives to improve meteor burst performance, and once the restrictive issues of throughput, wait time, and artificial noise have been resolved, meteor



burst will be integrated into primary roles, such as voice circuits, and become an integral part in Naval communications.

## APPENDIX A

### GLOSSARY OF ABBREVIATIONS, ACRONYMS, AND TERMS

ANSI	American National Standards Institute
ARQ	Automatic Repeat Request
B	Bandwidth in Hertz
BER	Bit Error Rate
CCITT	Comité Consultatif International de Téléphone et Télégraph
COMSEC	Communications Security
CRC	Cyclic Redundancy Check
d	Distance in Kilometers
D	D layer of the ionosphere
dB	Decibel
dBm	Decibel-milliwatt
DEBPSK	Differentially Encoded Binary Phase Shift Keying
E	E layer of the ionosphere
EMP	Electro-Magnetic Pulse
f	Frequency
F1	F1 layer of the ionosphere
FCC	Federal Communications Commission
FS	Federal Standard
FSK	Frequency Shift Keying
FSPL	Free Space Path Loss
HF	High Frequency
Hz	Hertz
k	Boltzman's constant
kbps	Kilo-bits per second
Km	Kilometer
KSR	Keyboard Send and Receive terminal
Kw	Kilowatt
L	Path loss
log	Logarithm
LORAN	Long Range Air Navigation
LOS	Line Of Sight
LUF	Lowest usable frequency
m	Meters
MBC	Meteor Burst Communications
MCC	Meteor Communications Corporation
MHz	Mega Hertz
MIL-STD	Military Standard
MUF	Maximum usable frequency
N	Noise (power)

NAK	Negative AcKnowledgement
NORAD	North American Aerospace Defense Command
NRZ	Non-Return to Zero
PCA	Polar Cap Absorption
PCs	Personal Computers
PSK	Phase Shift Keying
RF	Radio Frequency
SAC	Strategic Air Command
SCS	Soil Conservation Service
SID	Sudden Ionospheric Disturbance
SNOTEL	Snow Telemetry
T	Temperature in Degrees Kelvin
VHF	Very High Frequency
W	Watts

# APPENDIX B

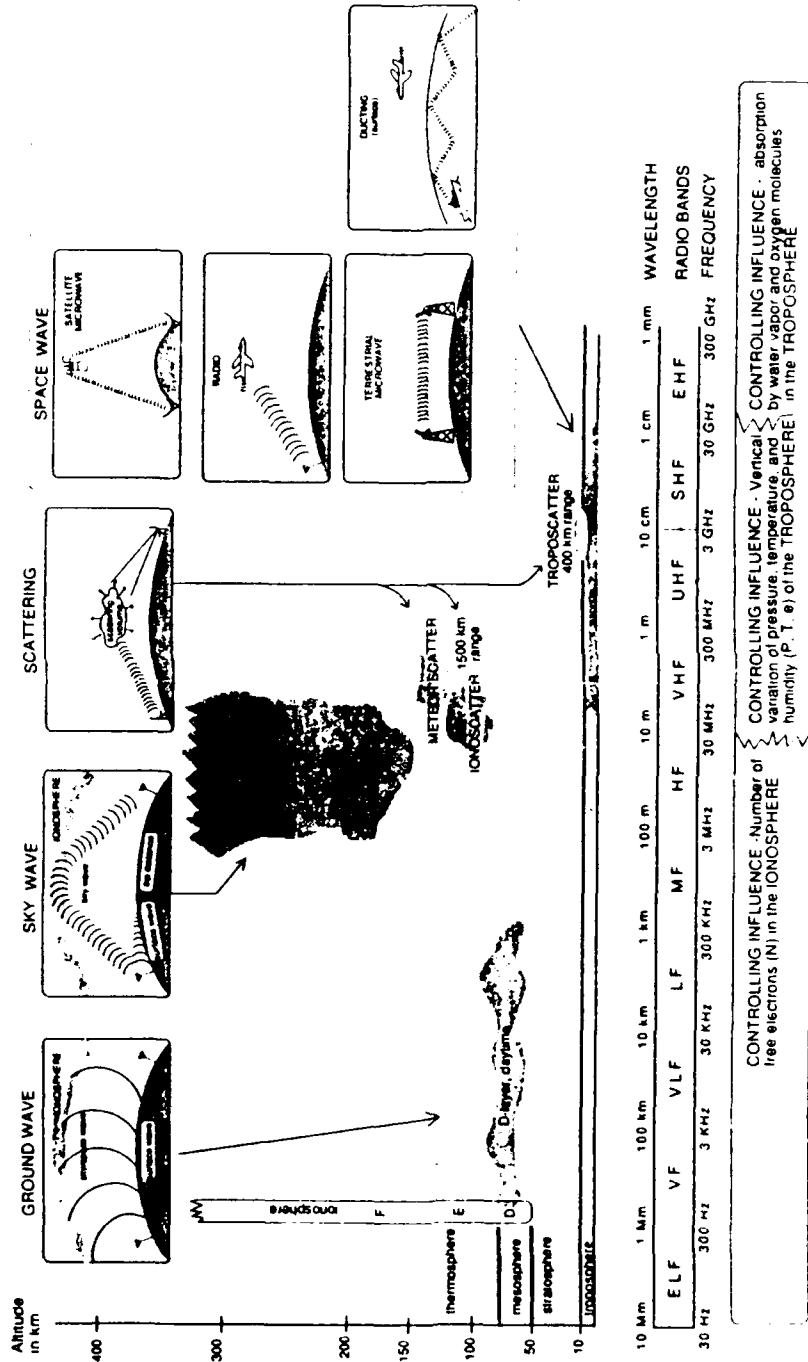

# APPENDIX C

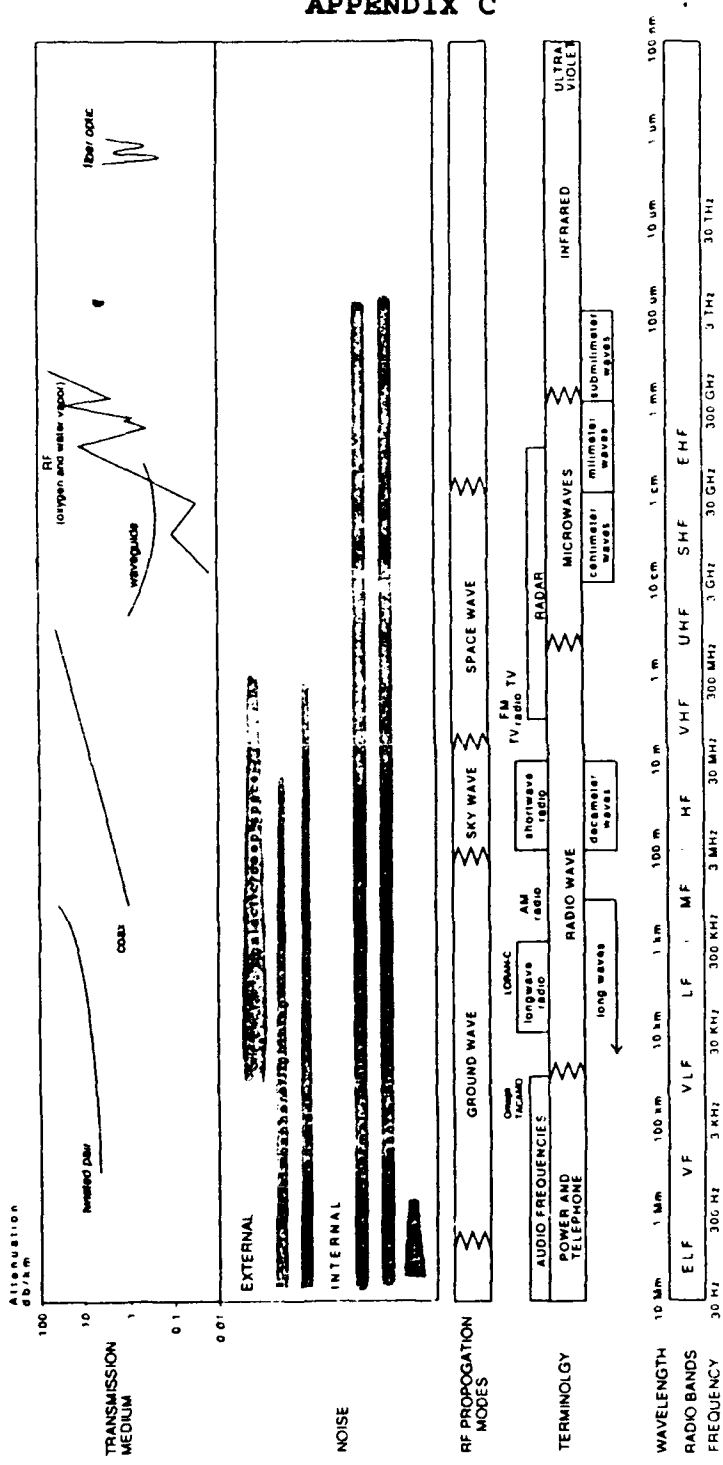

### LIST OF REFERENCES

1. "Meteor Communications Corporation," pamphlet published by Meteor Communications Corporation, Kent, Wa.
2. Schanker, J. Z., *Meteor Burst Communications*, Artech House, Inc., 1990.
3. Freeman, R. L., *Telecommunication Transmission Handbook*, 3rd ed., John Wiley & Sons, Inc., 1991.
4. "U.S. CECOM DEMONSTRATION," pamphlet published by Meteor Communications Corporation, Kent, Wa.
5. Oetting, J.D., "An Analysis of Meteor Burst Communications for Military Applications," *IEEE Transactions on Communications*, v.COM-28, n. 9, September, 1980.
6. Defense Communications Agency Center For Command And Control And Communications Systems, Military Standard, MIL-STD-188-135, *Interoperability and Performance Standards For Meteor Burst Communications-Initial Capability*, 20 September 1988.
7. Gray, G., "Meteor Burst Communications," *Signal*, May 1982.
8. Gottlieb, I., "Meteoric Bursts Could Keep Post-Attack Communications Open," *Defense Electronics*, November 1981.
9. Schaefer, G.L., and Johnson, D.E., "Development and Operation Of The SNOTEL System In The Western United States," paper presented by the U.S. Soil Conservation Service, Portland, Or., 1990.
10. "Meteor Burst Communication," pamphlet published by Meteor Communications Corporation, Kent, Wa.
11. Desourdis, R.I., Jr., and others, "Meteor Burst Link Performance Sensitivity to Antenna Pattern, Power Margin and Range", Science Applications International Corporation, 1988.

12. Coviello, G.J., and Lebow, I.L., "Preface, Military Communications- An Overview of the Special Issue," *IEEE Transactions on Communications*, v. COM-28, n. 9, September 1980.
13. Joint Chiefs of Staff, Department of Defense Dictionary of Military and Associated Terms, (JCS PUB 1-02), December 1989.
14. Smith, D.K., and Donich, T.G., "Maximizing Throughput Under Changing Channel Conditions", *SIGNAL*, June 1989.
15. Livesey, R.J., "The Aurora," *The Meteorological Magazine*, Vol. 118, No. 1409, December 1989.
16. Babcock, B.K., *Electronic Communications Systems and the Frequency Domain: An illustrated Primer for C3 Students*, Masters Thesis, Naval Postgraduate School, Monterey, Ca., June 1990.
17. Smith, R., "Chapter 3. Ionosphere and HF propagation," MR2419 notes, NPS, 1990.
18. McIntosh, D., *Meteorological Glossary*, Chemical Publishing Co., 1972.
19. Parker, S., *McGraw-Hill Dictionary Of Scientific And Technical Terms*, 4th ed., McGraw-Hill, 1989.
20. Schaefer, G.L., "SNOTEL- The World's First And Largest Data Collection System Using Meteor Burst Technology," paper presented at the International Symposium On The Hydrological Basis For Water Resources Management, Beijing, China, October 23-26, 1990.
21. The Office Of The Chief Of Naval Operations, NAVAIR-00-80U-24-1, *Meteorology For Naval Aviators, Volume 1- Fundamentals*, 1973.
22. Gaynor, F., *Pocket Encyclopedia Of Atomic Energy*, Jarrod and Sons, 1950.
23. U.S. Atomic Energy Commission *Nuclear Terms*, 2nd ed., Division of Technical Information, Washington, D.C., 1966.
24. Morgan, E.J., "Meteor Burst Communications: An Update," *SIGNAL*, March 1988.

25. National Communications System Office of Technology and Standards, "Proposed Federal Standard 1055, Telecommunications: Interoperability Requirements For Meteor burst Radio Communications Between Conventional Master And Remote Stations," 17 December 1991.
26. National Communications System Office of Technology and Standards, " Proposed Federal Standard 1056, Telecommunications: Interoperability Requirements For The Encryption of Meteor Burst Radio Communications," 7 October 1991.
27. National Communications System Office of Technology and Standards, " Telecommunications: Interoperability Requirements For Meteor Burst Radio Communications Between Networks By Conventional Master Stations," 17 December 1991.
28. Telephone conversation between R. Bauman, DARPA, and the author, 5 March 1992.
29. Telephone conversation between T. Donich, MCC, and the author, 11 March 1992.



## BIBLIOGRAPHY

- Akram, F., Sheikh, N., Javed A., and Grossi, M., "Impulse Response Of A MBC Channel Determined By Ray-tracing Technology," *IEEE Transactions On Communications*, Vol COM-25, April 1977,
- Bailey, D., Bateman, R., Kirby, R., "Radio Transmission At VHF By Scattering And Other Processes In The Lower Ionosphere," *Proceedings Of The IRE*, Vol 43, No 10, October 1955.
- Bartholome, P.J., and Vogt, I.M., "COMET-A New Meteor System Incorporating ARQ And Diversity Reception," *IEEE Transactions On Communication Technology*, Vol COM-16, No 2, April 1968.
- Bartholome, P.J., and Vogt, I.M., "Design Concepts For Transportable Ionoscatter Systems And Experimental Results," *IEEE Transactions On Communication Technology*, Vol COM-15, No 6, December 1967.
- Bliss, W.H., Wagner, R.J., Wickizer, G.S., "Wide-band Facsimile Transmission Over A 900-mile Path Utilizing Meteor Ionization," *IRE Transactions On Communications Systems*, Vol CS-7, No 4, December 1959.
- Bokhari, S.H., Javed, A., Grossi, M.D., "Data Storage For Adaptive Meteor Scatter Communication," *IEEE Transactions On Communication*, Vol 23, No 3, March 1975.
- Brown, D.W., "A Physical Meteor Burst Propagation Model and Some Significant Results For Communication System Design," *IEEE Journal On Selected Areas In Communications*, Vol SAC-3, September 1985.
- Campbell, L.L., and Hines, C.O., "Bandwidth Considerations In A JANET System," *Proceedings Of The IRE*, Vol 45, No 12, December 1957.
- Campbell, L.L., "Storage Capacity In A Burst Type Communication System," *Proceedings Of The IRE*, Vol 45, No 12, December 1957.

Carpenter, R.J., and Ochs, G.P., "The NBS Meteor Burst Communications System," *IRE Transactions On Communications Systems*, Vol CS-7, No 4, December 1959.

Crysdale, J.H., "Analysis Of The Performance Of The Edmonton-Yellowknife JANET Circuit," *IRE Transactions On Communications Systems*, Vol CS-8, No 1, March 1960.

Davis, G., Gladys, S., Lang, G., Luke, L., and Taylor, M., "The Canadian JANET System," *Proceedings of the IRE*, Vol 45, No 12, December 1957.

Eshleman, V.R., Mlodnosky, R.F., "Directional Characteristics Of Meteor Propagation Derived From Radar Measurements," *Proceedings On The IRE*, Vol 45, No-12, December 1957.

Forsythe, P.A., Vogan, E.L., "The Principles Of JANET- A Meteor Burst Communication System," *Proceedings Of The IRE*, Vol 45, No-12, December 1957.

JTAC, "Radio Transmission By Ionospheric And Tropospheric Scatter, Chapter Two," *Proceedings Of The IRE*, Vol 48, No 1, January 1960.

Meeks, M.L., and James, J.C., "On The Influence Of Meteor-radiant Distributions In The Meteor-scatter Communication," *Proceedings Of The IRE*, Vol 45, No 12, December 1957.

Montgomery, G.F., and Sugar, G.R., "The Utility Of Meteor Bursts For Intermittent Radio Communication," *Proceedings Of The IRE*, Vol 45, No-12, December 1957.

Rach, R.A., "An Investigation Of Storage Capacity Required For A Meteor Burst Communication System," *Proceedings Of The IRE*, Vol 45, No 12, December 1957.

Vincent, W.R., Wolfram, R.T., Sifford, B.M., Jaye, W.E., and Peterson, A.M., "Analysis Of Oblique Path Meteor Propagation Data From The Communications Viewpoint," *Proceedings Of The IRE*, Vol 45, No-12, December 1957.

### INITIAL DISTRIBUTION LIST

1. Defense Technical Information Center 2  
Cameron Station  
Alexandria, VA 22304-6145
2. Library, Code 0142 2  
Naval Postgraduate School  
Monterey, CA 93943-5002
3. Administrative Sciences Department 2  
Naval Postgraduate School  
Attn: Professor Dan C. Boger, Code AS/Bo  
Monterey, CA 93943-5000
4. Electrical and Computer Engineering Department 1  
Naval Postgraduate School  
Attn: MAJ T. Schwendtner, Code EC/SC  
Monterey, CA 93943-5000