



2

2/24/92

Quarterly  
Technical Report. Jun 16 - Sep 15, 1991

THE IMPACT OF ORGANIZATION STRUCTURE ON TEAM DECISION  
MAKING UNDER STRESS AND UNCERTAINTY

Grant #:N00014-90-J-1680  
R&T Project Number:  
uri 5202-9002

Paul E. Lehner

Center of Excellence in Command, Control, Communications  
and Intelligence  
George Mason University  
Fairfax, Virginia 22030

GMU/C3I-114-IR

Office of Naval Research  
Arlington, Virginia 22217-5000

DTIC  
SELECTE  
MAR 27 1992  
S D D

unlimited

The objective of the research reported herein is to investigate coordination in team decision making. Particular focus is placed on the identification and characterization of variables that enhance coordination and enable teams to maintain coordinated action under stressful conditions characteristic of tactical environments.

This document has been approved  
for public release and sale; its  
distribution is unlimited.

Team Decision Making - Distributed Intelligence Systems -  
Belief Networks - Petri Nets

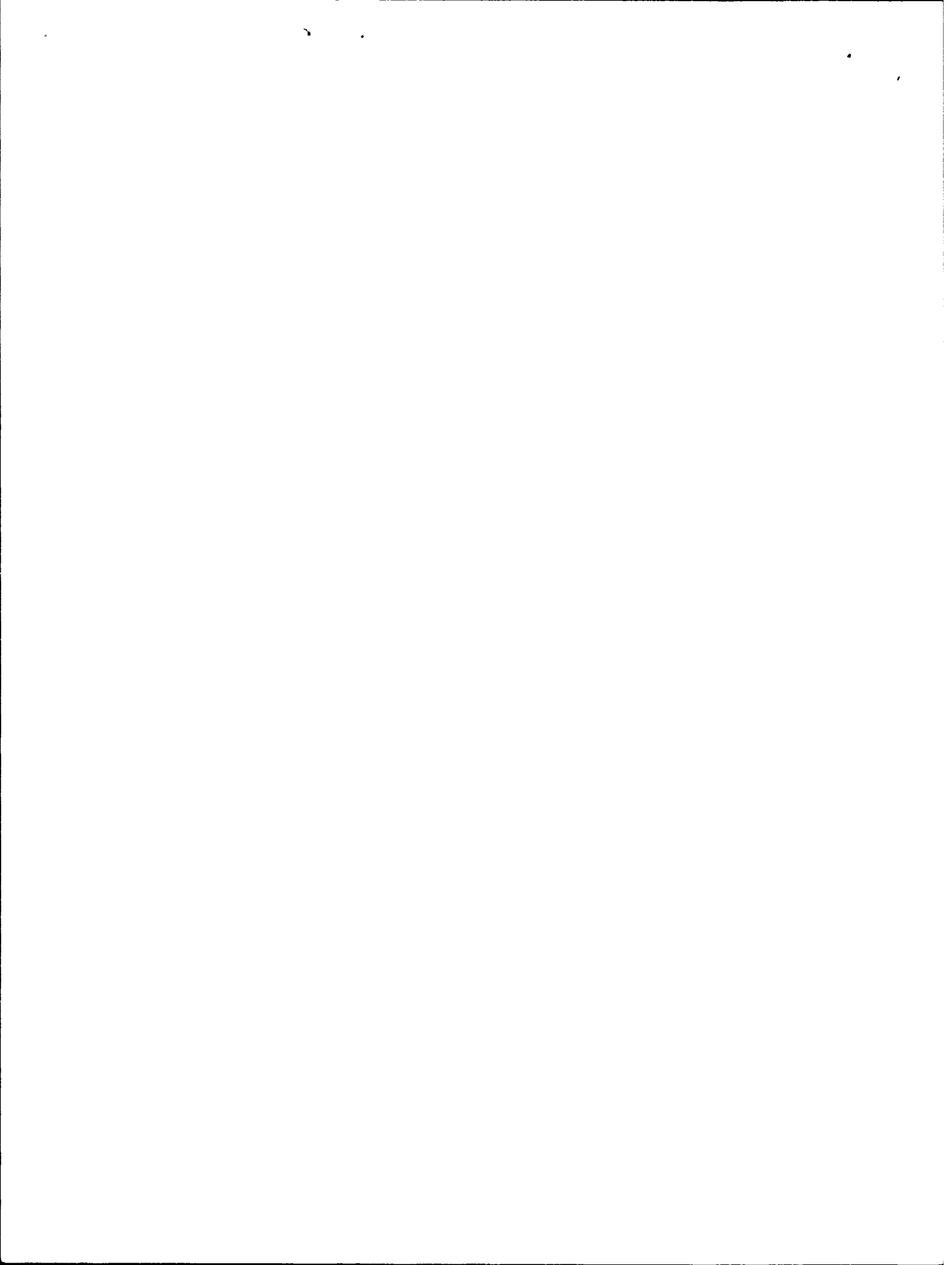

**CENTER OF EXCELLENCE IN  
COMMAND, CONTROL, COMMUNICATIONS AND INTELLIGENCE**

**GEORGE MASON UNIVERSITY  
Fairfax, Virginia 22030**

Accession For	
NTIS	CRA&i <input checked="" type="checkbox"/>
DTIC	TAG <input type="checkbox"/>
Unannounced	<input type="checkbox"/>
Justification	
By	
Distribution	
Availability Codes	
Dist	Availability Codes
<b>A-1</b>	

**QUARTERLY TECHNICAL REPORT**

for the period

16 June 1991 - 15 September 1991

for

**THE IMPACT OF ORGANIZATION STRUCTURE ON TEAM  
DECISION MAKING UNDER STRESS AND UNCERTAINTY**

Grant Number N00014-90-J-1680  
R&T Project Number uri 5202-9002

Submitted to:  
Dr. W. S. Vaughan, Jr. (3 copies)  
Office of Naval Research  
800 North Quincy Street  
Arlington, Virginia 22217-5000

Copies to:  
Director, Naval Research Laboratory  
Defense Technical Information Center  
Administrative Grants Office, ONR

Submitted by:

**Paul E. Lehner**  
*Principal Investigator*

February 24, 1992

Report #: GMU/C3I-114-IR

037

**92-07856**



## **1. PROGRAM OBJECTIVES**

The objective of this research is to investigate coordination in hierarchical team decision making. Particular focus is placed on the identification and characterization of variables that enhance coordination and enable teams to maintain coordinated action under stressful conditions characteristic of tactical environments.

## **2. STATEMENT OF WORK**

The research proposal identified three major tasks which define a sequence of three team decision making experiments. Each experiment involves the combined use of analytic models of the experimental setting and psychological models of human behavior to design the experiment and to predict performance.

*Year 1 Experiment* - The Year 1 experiment expands on the work of Jin (1990). The experiment will investigate the effects of time stress on team decision making performance. The experiment will be hosted on the testbed developed by Jin at MIT.

*Year 2 Experiment* - This experiment will focus on issues related to fixed versus variable structure organizations.

*Year 3 Experiment* - This experiment will extend the results of the previous experiments.

## **3. RESEARCH PLAN**

The research plan describes our strategy for meeting the program objectives and fulfilling the research tasks. This research plan will evolve during the duration of this effort.

Our research plan has been organized into three highly related research areas:

- (a) Analytical models of C3I organizations that incorporate coordination variables,
- (b) Descriptive models of team decision making.
- (c) Prescriptive models of team decision procedures

The focus of the first area is the development of methodologies, models, theories and algorithms directed toward the derivation of superior tactical decision, coordination, and communication strategies of agents in organizational structures. Both fixed and variable organizational structures are considered. However, the focus is on modeling variable organizational structures and how those structures adapt under conditions of stress. The framework for this research is analytic.

The focus of the second area is the development of descriptive models of human decision making that are relevant to predicting team decision making performance under stress. For this work, it is assumed that the team members are well-trained. Consequently, the focus of the research is to identify conditions under which team performance degrades because one or more team members cannot effectively execute trained procedures properly.

The focus of the third area is to develop a prescriptive methodology for specifying team decision making procedures. This work will combine the normative and descriptive research in the first two areas to develop a methodology for deriving a set of robust team decision procedures.

This includes procedures for coordinating team decision making activities and adaptation of coordination procedures.

Each of the above areas is based on different scientific and engineering disciplines. It is our objective to merge these three research areas into a single theory of team design. We anticipate moving toward this objective through out the duration of this research program.

#### **4. STATUS REPORT**

In the context of the three tasks and research plan outlined above, a number of specific research problems have been formulated. These are being addressed by project faculty and by graduate assistants under the direction of project faculty. Each research problem is discussed below. Research problems which were completed during this period are described in some detail.

##### **4.1 CORDINATION IN DECISION MAKING ORGANIZATIONS**

**Background** - The concept of an organization embodies two meanings. One is the physical entities and the interactions between them which form the organization. Another is the rules that govern the operation of the organization. We call all these physical entities and their interactions the system, and we characterize the operation of the system as coordination.

A key question in modeling and designing organizations is whether these two concepts can be decoupled. Mr. Zhuo Lu is investigating this problem under the supervision of Prof. Alexander H. Levis.

From the modeling point of view, if we can successfully decouple the organization model into two layers: the System Layer and the Coordination Layer, the modeling problem can be considered as two sub-problems: How to model the System Layer and how to model the Coordination Layer. The System Layer models all the system entities (including their interactions) with their built in functions; and the Coordination Layer models the rules of coordination for each system entity. Therefore, the modification of the Coordination Layer will not affect the System Layer. This may also provide a potential to formulate the organization by the mathematical description of System Layer and Coordination Layer.

From the designing point of view, the design problem may be divided into several sub problems:

- How to design the System Layer
- How to design the Coordination Layer given the System Layer
- How to modify the System Layer if the Coordination Layer is given

Monguillet and Levis (1988) initiated the investigation of variable structure Decision Making Organizations. Based on theory of Predicate Transition Nets (PTN) (Genrich, 1987), Monguillet extended the framework of System Effectiveness Analysis for comparing both variable and fixed organizations.

They also have refined the concept of variability. Three types of variability have been defined:

- Type 1-variable, if it adapts to the input it processes.
- Type 2-variable, if it adapts to environmental changes
- Type 3-variable, if it adapts to changes in the system's parameters

An appropriate mathematical framework is that of Colored Petri Nets (CPN) (Jensen, 1987), Demaël and Levis (1989) used it to investigate systems that adapt their structure of interactions to the input they process. Grevet and Levis (1988) have addressed the coordination problem in two classes of issues:

- The synchronization of the activity during the decision making processes.
- The consistency of the information processed by the different members of the organization.

In that work, a measure of coordination was introduced that depended on two other measures: synchronization and information consistency. .

#### **Progress to date:**

For an organization, given the System Layer, which includes all physical entities and their interactions, the coordination between these entities can affect the organization's performance dramatically. The formal definitions for coordination still remains unclear. We have noticed coordination embodies a lot of meanings. Normally, these coordination meanings fall into two categories: either it deals with time or it involves information.

The nature of the coordination needs to be explored. The solution to the coordination problems consists of the following issues:

- The concept of coordination needs to be refined for an organization.
- A mathematical framework needs to be developed to describe the coordination in an organization.
- Coordination should be modeled explicitly. Therefore, the complete model for an organization will consist of two levels: The System Layer and the Coordination Layer.
- A methodology should be proposed for designing the Coordination Layer given the System Layer, and modifying the System Layer given the Coordination Layer.

In this research effort, we only focus on the information flows when the organization is performing a task. When the inputs, the environment and/or the system parameters change, the

This work will investigate how the Coordination Layer should be designed so that the organization can be adaptable to the three types of variability. The organization should have the capability of reconfiguring itself with respect to the environmental and system parameter changes. This is an extension of earlier work in which an organization was adaptable only to inputs. In the research task, the following issues will be addressed:

- An extension of earlier work on the coordination constraint (Demaël, 1989) and an algorithm for checking that constraint.
- A framework for an organization which can be adaptable to all the three types of variability defined by Monguillet (1987).
- A mathematical framework, based on Colored Petri Nets, for representing an organization with three types of variability.

- A methodology for designing the Coordination Layer given the System Layer, so that the organization can adapt to the three types of variability.

## Documentation

Z. Lu and A. H. Levis, "A Colored Petri Net Model of Tactical Decision Making," *Proc. 1991 Symposium on C2 Research*, National Defense University, Ft. McNair, Washington, DC, June 1991.

Z. Lu and A. H. Levis, "A Colored Petri Net Model of Distributed Tactical Decision Making," to appear in *Proc. 1991 IEEE International Conference on Systems, Man, and Cybernetics*, October 1991.

## 4.2 DESIGN OF MULTILEVEL HIERARCHICAL ORGANIZATIONS

**Background** - Both centralized and distributed organizations are characterized by the hierarchical structure. These organizational architectures are described by families of structures with each family concerned with the behavior of the organization as viewed from a different level of abstraction. Previous efforts under the Distributed Tactical Decision Making program resulted in a number of methodologies to design and generate *flat* architectures; the system is viewed only from a single level of detail (Remy and Levis, 1988). The basic decision making entity assumed throughout these methodologies was a human decision maker (DM). The current effort is directed towards a methodology to generate in some orderly manner, either by using the existing algorithms iteratively or by some new algorithm, the organizational structures for *multilevel* hierarchical organizations. This research task is necessary if realistic decision making organizations are to be modeled and analyzed. The research task is being carried out by Mr. Syed Abbas Zaidi under the supervision of Prof Alexander H. Levis. This report first defines the problem and then describes the results obtained.

The following four issues must be addressed in order to implement such a methodology;

- (a) The concept of multilevel hierarchical organizational structures needs to be formulated analytically.
- (b) A mathematical framework that is appropriate for the formulation of the design problem should be identified.
- (c) Sets of constraints have to be identified for different levels in the organization to reflect design requirements and to keep the problem of generating organizational structures computationally feasible.
- (d) A set of connectivity rules needs to be formulated in order to integrate organizational structures defined at different degrees of abstraction.

### *Multilevel Hierarchical Systems*

The concept of a multilevel, hierarchical system is defined in Mesarovic et al. (1970). Some of the characteristics which every hierarchy has are: *vertical arrangement of subsystems which comprise the overall system, priority of action or right of intervention of the higher level subsystems, and dependence of the higher level subsystems upon actual performance of the lower level.*

Mesarovic et al. (1970) defined three types of hierarchical systems. The classification is based on three notions of levels:

- The level of description or abstraction, the *stratum*.
- The level of decision complexity, the *layer*.
- The organizational level, the *echelon*.

The term *level* is reserved as a generic term referring to any of these notions when there is no need to distinguish between them.

The concept of stratum is used for modeling organizational architectures when viewed from different levels of abstraction, while the concept of layer is introduced in reference to the vertical decomposition of a decision problem into sub-problems. The concept of echelon refers to the mutual relationship between Decision Making Units (DMU) comprising a system.

It is necessary to make a clear distinction as to which notion of level one is using when describing a hierarchical system. The type of multilevel, hierarchical systems under investigation are *stratified systems*, where the system is described by a family of structures each concerned with the behavior of the system as viewed from a different level of abstraction, the *stratum*. A Stratified Decision Making Organization is defined formally as follows;

A *Stratified Decision Making Organization (SDMO)* is defined to be a Decision Making Organization (DMO) in which a system on a given stratum is a subsystem on the next higher stratum. In a SDMO, DMUs can be either Decision Making Sub-Organizations (DMSO) or human Decision Makers (DM) depending upon the level of abstraction used to represent the organizational structure of the DMO.

For illustrative purposes, a description of a general SDMO is presented in Figure 4.2.1.

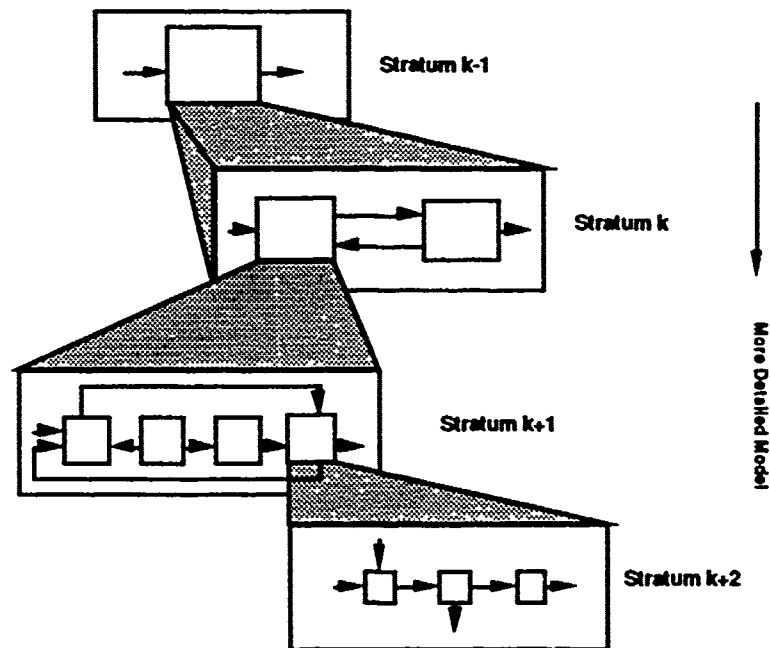

Figure 4.2.1 A Stratified Decision Making Organization (SDMO)



In a SDMO, the highest stratum, stratum '0', contains only one organizational structure, the *node*, which represents the entire organization (SDMO). The nodes at all other strata are referred to as Decision Making Units or DMUs. The node at stratum '0' shows the highest level of abstraction that can be used to describe an organizational structure. On the other hand, the  $n^{\text{th}}$  stratum contains an elaborated and detailed description of the DMO at the lowest level of abstraction that is determined by the designer of the organization. The range of 'n' is defined as  $1 \leq n \leq N$ , where 'N' represents the lowest possible stratum at which the DMUs cannot be decomposed further. The determination of the value of 'N' is application dependent, i.e., it depends upon the kind of organization being modeled, and on the definition of strata used to describe the organization. For example, in human organizations, 'N' represents the stratum at which the DMUs are individual human decision makers (DMs)

A DMU at stratum 'k', where  $1 \leq k < n$ , is defined as a *compound node* to reflect the Petri Net formalism that is used to describe the organizational structure. All nodes are labeled by an alphanumeric code,  $DMU_{ik}$ , where 'i' represents the node number at stratum 'k'. The set of all the nodes at stratum 'k' contains  $|\mu_k|$  elements, i.e.,

$$\mu_k = \{1, 2, \dots, |\mu_k|\} \text{ and } i \in \mu_k.$$

The following property holds for every stratified decision making organization (SDMO): The number of nodes at a stratum is larger than or equal to the number of nodes in the stratum immediately above it.

$$|\mu_n| \geq |\mu_{n-1}| \geq \dots \geq |\mu_{k+1}| \geq |\mu_k| \geq |\mu_{k-1}| \geq \dots \geq |\mu_0| = 1 \quad 1 \leq n \leq N$$

This follows from the fact that a system on a stratum is comprised of a number of subsystems which are defined for the next lower stratum; the number of nodes at a given stratum is given by the sum of the subsystems of the individual nodes at the next higher stratum.

## Progress to Date

### *Mathematical Formulation*

The mathematical formulation of the problem is based on Petri Net theory. The methodology is formulated using the language of Hierarchical Petri Nets. The concept of having a family of organizational structures for a system where each member of the family describes the system's behavior at a different degree of abstraction is realized by *folding* and *unfolding* the organizational structures. The formal folding and unfolding procedures for Hierarchical Petri Nets were found suitable for representing organizational structures at different levels. A brief description of these procedures is presented in the following subsection.

### *Folding and Unfolding a Net*

A Petri Net is compounded if it is replaced or aggregated by a single transition or a place, called compound transition/place. A Petri Net model of a system is said to be folded, if certain subnets of the net are aggregated by compound transitions and/or compound places. The folded net obtained as a result describes the system at a higher degree of abstraction. The original detailed description of the system net can be retrieved by uncomounding the compound transitions and compound places. The process of uncomounding all the compound transitions and compound places is termed unfolding the net.

The organizational structures represented in terms of Petri Nets are folded by creating compound transitions representing different suborganizations. *The processes of folding and unfolding do not effect the Petri Net properties of the structures; the structures obtained as a result of folding and unfolding are legitimate, executable, Petri Nets.* Figure 4.2.2 presents a Petri Net with two of its subnets outlined by dotted boxes. The outlined subnets are replaced by their compound transition representation in Figure 4.2.3. The Petri Net in Figure 4.2.3 is the folded version of the net in Figure 4.2.2. It represents the same system in Figure 4.2.2 but at a higher degree of abstraction.

The subnets that are replaced by compound transitions as a result of folding are shown in Figures 4.2.4 and 4.2.5. Figure 4.2.4 represents the net replaced by compound transition **t1** along with the *port nodes*, while the subnet replaced by the compound transition **t2** is shown in Figure 4.2.5. The *port nodes*, shown by the label **B-in/out** in the figures, are the places which preserve the connectivity of the original structure being folded. They are used to retrieve the original structure at the time of uncomounding the compound transitions.

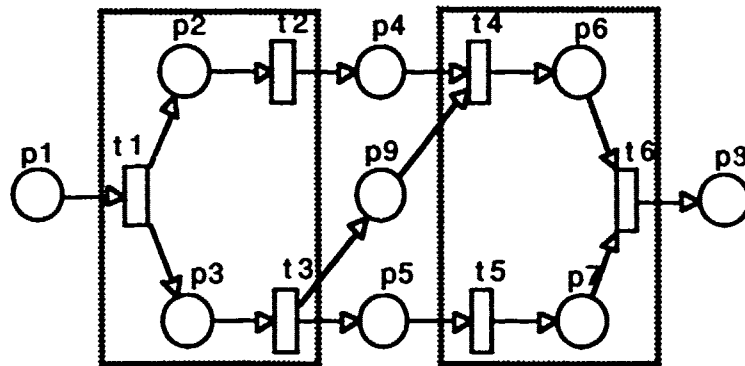

Figure 4.2.2 Petri Net of a System

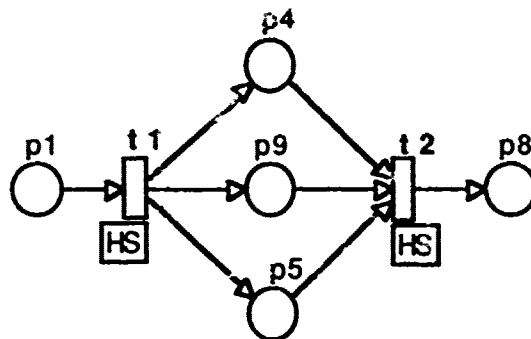

Figure 4.2.3 Folded Petri Net

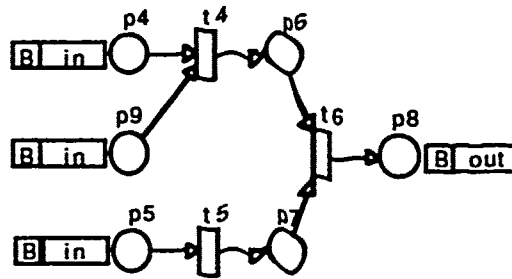

Figure 4.2.4 Subnet Replaced by Compound Transition t1

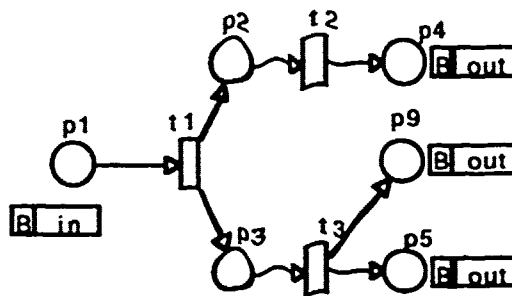

Figure 4.2.5 Subnet Replaced by Compound Transition t2

The places p4, p5, and p9 in Figure 4.2.3 are all the output places of the compound transition t1 and input places of compound transition t2. If the system's behavior at a higher degree of abstraction is desired to be depicted, the three places p4, p5, and p9 can also be represented by an equivalent single place p2 with input and output arcs having a weight of 3 as shown in Figure 4.2.6. If the single equivalent place p2 models the flow of information from the aggregated processes represented by t1 to aggregated processes represented by t2 and the three places between t1 and t2 in Figure 4.2.3 represent a redundancy in the flow of information as the tokens are defined to be indistinguishable then Figure 4.2.7 may be used where there is no weighting on the input and output arcs of p2.

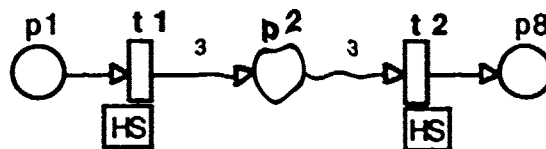

Figure 4.2.6 Folded Version of the Net in Figure 4.2.2

The net in Figure 4.2.7 can be unfolded to the net in Figure 4.2.2 by uncomposing the compound transitions t1 and t2. The places that are represented by the equivalent place are defined in the subnets in Figures 4.2.4 and 4.2.5, therefore, whenever the compound

transitions are uncompounded, all the places present in the original net will be retrieved from the subpages producing the original detailed description of the net in Figure 4.2.2.

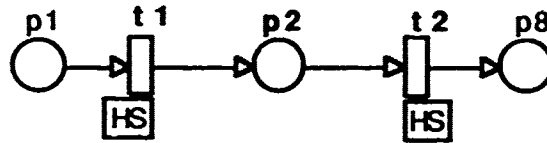

Figure 4.2.7 Folded Version of the Net in Figure 4.2.2

The folding process presented in this section is used in the design methodology to represent the process of going from one description of the organizational structure to another at a different level (stratum).

The process of folding Petri Nets also refers to a technique used to translate the Ordinary Petri Nets to their Colored Petri Net representations. Since Colored Petri Nets are not used in this thesis, the folding process mentioned is not discussed here. Interested readers are referred to Jensen (1990).

#### Single Interacting Compound Node

The folding procedure described above was applied to the organizational structures with human DMs as DMUs. The effort led to the definition of the *Compound node*: A DMU at stratum 'k', where  $1 \leq k < n$ , is defined to be a compound node. Therefore, a *compound node structure* can be considered as a *folded structure of the lower-strata DMUs and their interconnections*. Figure 4.2.8 presents a five stage model of a single interacting compound node.

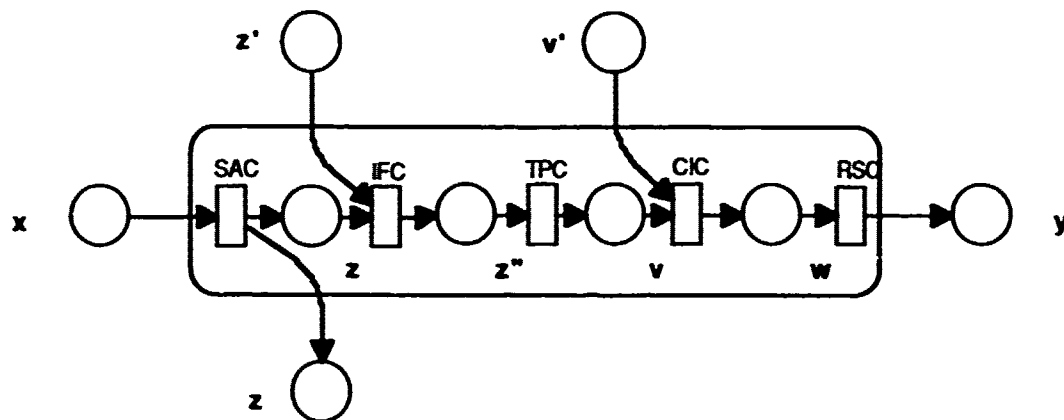

Figure 4.2.8 Single Interacting Compound Node

The input and output stages of the compound node are the same as those of a DM defined by Levis (1992). The physical interpretation of these interactions, however, varies slightly from that of a single DM.

A compound node receives input or data x from the external environment (sensors) or from other compound nodes of a system. The incoming data are processed in the compound

situation assessment (SAC) stage to get the assessed situation  $z$ . This variable may be sent to other compound nodes. If the compound node receives assessed data from other compound nodes, these data  $z'$  are fused together with its own assessment  $z$  in the compound information fusion (IFC) stage to get the revised assessed situation  $z''$ . The assessed situation is processed further in the compound task processing (TPC) stage to determine the strategy to be used to select a response. The variable  $v$  contains both the assessed situation and the strategy to be used in the compound response selection stage. A particular compound node may receive a command  $v'$  from superordinate compound nodes. This is depicted by the use of the compound command interpretation (CIC) stage. The output of that stage is the variable  $w$  which contains both the revised situation, assessment data and the response selection strategy. Finally, the output or the response of the compound node,  $y$ , is generated by the compound response selection (RSC) stage.

The input and output stages of a compound node are the same as those of a DM; therefore, the organizational structure with compound nodes as DMUs will have the same kind of topology as of those with human decision makers. A generalized folding/unfolding procedure can be described for any organizational structure in stratum 'k', where  $1 \leq k \leq n$ , if it is desired to have a stratum 'k-1' or 'k+1' description of the same organization.

#### *Labeling of Transitions and Places*

The labeling of places and transitions is introduced primarily for computational purposes. It also provides an algorithmic approach for folding and unfolding the organizational structures at different strata. The labeling schemes for transitions and places of a DMU in an arbitrary stratum is illustrated with the help of an organizational structure where a DMU 'q' is defined in stratum 'k-1' with two subsystems, DMUs 'i' and 'j', in stratum 'k'. The DMU 'i' has two subsystems defined at a lower stratum, namely DMUs 'a' and 'b', while DMU 'j' has DMUs 'c' and 'd' as its subsystems at stratum 'k+1'. A description of the labeling technique follows.

The transitions of a compound node are *compound* transitions; they represent a subnet comprised of transitions and places defined at a lower stratum. Table 4.2.1 gives the labels associated with all possible transitions of an organizational structure in stratum 'k'. It can be seen in the table that transitions are labeled to reflect the DMU they belong to, the stage they represent, and the stratum for which they are defined.

TABLE 4.2.1 Labeling of Transitions

Description	Label
Input transition	$t_{0qk-1}$
Output transition	$t_{6qk-1}$
SA/SAC of DMU 'i'	$t_{1ik}$
IF/IFC of DMU 'i'	$t_{2ik}$
TP/TPC of DMU 'i'	$t_{3ik}$
CI/CIC of DMU 'i'	$t_{4ik}$
RS/RSC of DMU 'i'	$t_{5ik}$

The generic label of an internal transition will now be  $t_{srk}$  with  $1 \leq s \leq 5$  and  $1 \leq r \leq m$  and  $0 \leq k \leq n$ . The index 's' represents the stage, 'i' the DMU number, and 'k' the stratum.

On the other hand, a place will be labeled with a minimum of three and a maximum of five digits. The minimum number of digits necessary to completely characterize a place will be used. The complete characterization of a place involves the stage it represents, the DMU to which it belongs, and the stratum for which it is defined. The labeling scheme for places of an organizational structure is given in the Table 4.2.2.

TABLE 4.2.2 Labeling of Places

Transitions		Corresponding Place Label
Input	Output	
	→ $t_{0qk-1}$	$P_{0qk-1}$
$t_{0qk-1}$	→ $t_{1ik}$	$P_{1ik}$
$t_{1ik}$	→ $t_{2ik}$	$P_{2ik}$
$t_{1ik}$	→ $t_{2jk}$	$P_{2ijk}$
$t_{2ik}$	→ $t_{3ik}$	$P_{3ik}$
$t_{3ik}$	→ $t_{4ik}$	$P_{4ik}$
$t_{4ik}$	→ $t_{5ik}$	$P_{5ik}$
$t_{5ik}$	→ $t_{6qk-1}$	$P_{6ik}$
$t_{5ik}$	→ $t_{1jk}$	$P_{6ij1k}$
$t_{5ik}$	→ $t_{2jk}$	$P_{6ij2k}$
$t_{5ik}$	→ $t_{4jk}$	$P_{6ij4k}$
$t_{6qk-1}$	→	$P_{7qk-1}$

#### *Folding and Unfolding an Organizational Structure*

In order to obtain the stratum 'l', where  $0 \leq l \leq k-1$ , description of an organizational structure in stratum 'k', the structure in stratum 'k' is first folded to obtain the stratum 'k-1' description of the organization. In order to fold an organization structure in stratum 'k', all the subsystems and their interactions that are defined in stratum 'k' are folded into compound node structures. These compound nodes are now defined as DMUs of the stratum 'k-1' description of the organization. All the interactions that were defined only in stratum 'k' are no longer present in this description.

On the other hand, the interactions defined in higher strata are still represented in the description. Therefore, while folding an organizational structure in stratum 'k' to obtain the stratum 'k-1' description of the organization, only those subsystems and interactions are folded that have 'k' as their stratum number in their labeling scheme with the exception of input and output transitions and places that have 'k-1' as the stratum number. These transitions and places are used to map the subsystems to their compound node representation in the next higher stratum. Figure 4.2.9 shows a subsystem of an organizational structure identified in a stratum 'k' description of the organization. Note that the subsystem identified for illustration has only two DMUs 'i' and 'j' and all the allowable interactions from 'i' to 'j' are shown in the figure. The reason for selecting two DMUs for illustration is evident from the fact that the interactional structures of organizations or suborganizations are defined in terms of the interactions between pairs of their DMUs. Therefore, the folding process illustrated by two DMUs can be applied to

any number of DMUs comprising an organization or suborganization. Figure 4.2.10 presents the compound node structure of the subsystem in Figure 4.2.9. Note that all the interactions defined in stratum 'k' do not have their representation in stratum 'k-1' description of the subsystem, whereas the interactional place  $p_{6rq4k-1}$  is present in the description. It can also be seen that the transitions and places of the compound node inherited the compound node number from the input and output places and transitions of the subsystem in Figure 4.2.9.

Once an organizational structure in stratum 'k' is folded to stratum 'k-1', the same procedure can be applied iteratively to fold the structure to any stratum higher than the current stratum. Note that the folding procedure must be applied sequentially; it is not possible to fold the structure in stratum 'k' to stratum 'k-2' without having an intermediate stratum 'k-1' description of the organization. Also note that the nets obtained after folding process are executable Petri Nets.

Figure 4.2.11 presents the lower stratum description, with all possible interactions, of compound transitions  $t_{1qk-1}$ ,  $t_{2qk-1}$ ,  $t_{3qk-1}$ ,  $t_{4qk-1}$ , and  $t_{5qk-1}$ . In the figure, all the possible input interactions are shown with the transitions representing the stages of  $DMU_{ik}$ , while all the possible output interactions are shown with the transitions of  $DMU_{jk}$ . In describing different interactions, generic labels are used for interactions that are defined in a stratum ' $\lambda$ ', where  $k \leq \lambda \leq 1$ , among generic DMUs a and b. The generic labels ' $\mu$ ' and ' $\gamma$ ' are used to represent the stages of DMUs, therefore  $1 \leq \mu, \gamma \leq 5$ . The generic labels account for all those interactions that are either defined at a higher stratum than stratum 'k' or the interactions implemented by special constraints,  $R_p$ . All the places shown with label 'B in/out' are defined as port nodes. The port nodes will retain their existence in the stratum 'k-1' description of the organization, if they are not replaced by their equivalent representation. The transitions and non-port nodes in Figure 4.2.11 represent the actual subnets being replaced by the compound transitions.

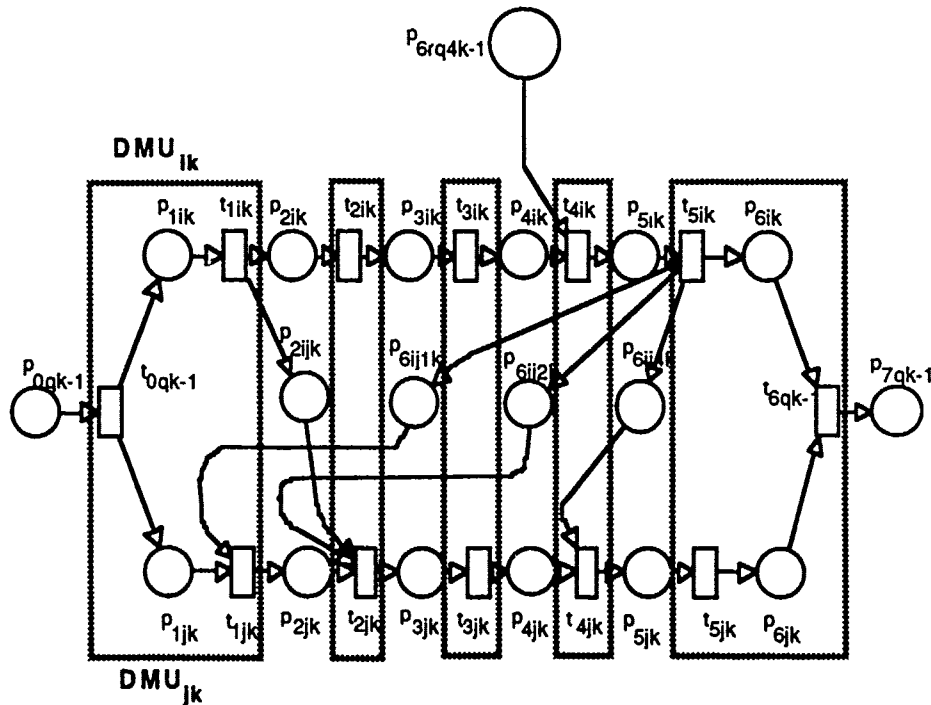

Figure 4.2.9 Subsystem of an Organizational Structure

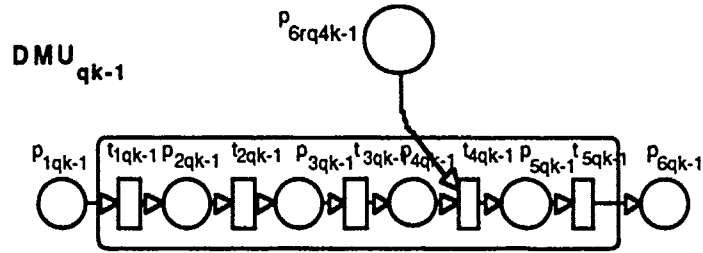

Figure 4.2.10 Compound Node Representation of the Structure in Figure 4.2.9

Unfolding, on the other hand, is the process in which an organizational structure in a particular stratum is decomposed into its subsystems and their mutual interactions defined in lower strata. The process yields a more elaborate and detailed description of the organization under study. In this process, the compound transitions are replaced by the subnets representing these compound transition in a lower stratum. This process of un-compounding the compound transitions continues till the desired degree of abstraction used to describe the system is achieved.

#### Mathematical Model

The interaction structure of an  $m$ -DMUs compound node 'i',  $i \in \mu_k$ , is represented by the following tuple.

$$\Sigma_{ik+1} = \{ e, s, F, G, H, C \} \quad i \in \mu_k \quad k = 0, 1, 2, \dots, n$$

$\Sigma_{ik+1}$  represents the interactional structure of the compound node 'i', when the level of abstraction used to describe the structure is of stratum 'k+1'. The compound node 'i' itself is defined as a DMU for stratum 'k'.

The six arrays  $e, s, F, G, H, C$  are defined as follows;

- Two  $m \times 1$  vectors  $e$  and  $s$  representing the interactions of the  $m$ -DMUs ('a' and 'b') with the external processes.

$$\begin{aligned} e &= [e_a] & a &= 1, 2, \dots, m & m &\in \mu_{k+1} \\ s &= [s_a] & a &= 1, 2, \dots, m & m &\in \mu_{k+1} \end{aligned}$$

- Four  $m \times m$  matrices  $F, G, H, C$  representing the interactions among the decision making nodes/compound nodes of the organizational structure represented by compound node 'i'.

$$\begin{aligned} F &= [F_{ab}] & G &= [G_{ab}] & a &= 1, 2, \dots, m \\ H &= [H_{ab}] & C &= [C_{ab}] & b &= 1, 2, \dots, m & m &\in \mu_{k+1} \end{aligned}$$



The diagonal elements of the matrices **F**, **G**, **H**, and **C** are set to '0'; DMUs are not allowed to interact with themselves.

$$F_{aa} = G_{aa} = H_{aa} = C_{aa} = 0 \text{ for } a = 1, 2, \dots, m \text{ where } m \in \mu_{k+1}$$

The six-tuple  $\Sigma_{ik+1}$  is called a **Well Defined Net (WDN)** of compound node 'i' which is located at stratum 'k'. The dimension of the WDN is 'm', where 'm' is the number of decision making units (DMU) in 'i'. The set of all WDN of dimension m will be denoted by  $W_{ik+1}(m)$ .

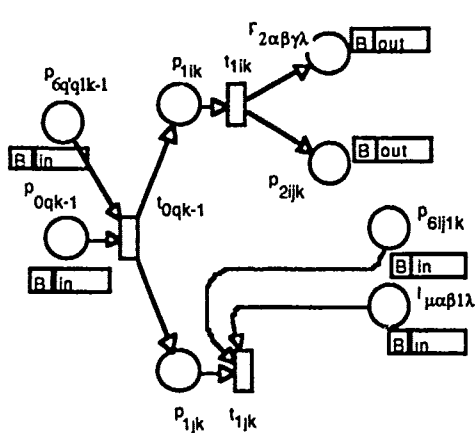

a) Subnet replaced (folded) by  $t_{1qk-1}$

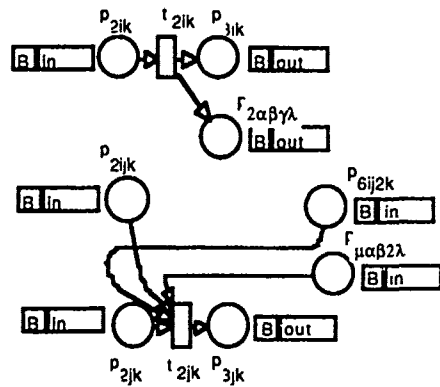

b) Subnet replaced (folded) by  $t_{2qk-1}$

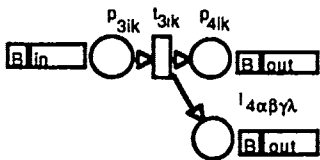

c) Subnet replaced (folded) by  $t_{3qk-1}$

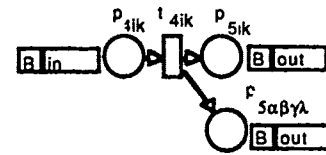

d) Subnet replaced (folded) by  $t_{4qk-1}$

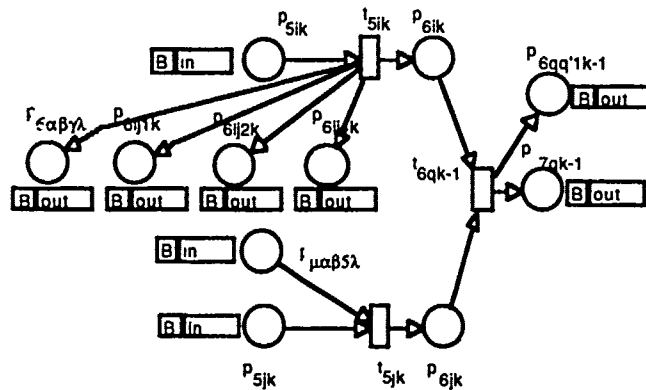

e) Subnet replaced (folded) by  $t_{5qk-1}$

Figures 4.2.11 Lower Stratum Representation of Compound Transitions

There is a direct-one-to-one correspondence between interactional places and the non zero elements of the matrix representation of a WDN. Each '1' in the arrays representing a WDN corresponds to the presence of a particular kind of interaction between two DMUs or between a

DMU and the external environment. Table 4.2.3 lists all possible *links* and gives for each of them the correspondence between the matrix and Petri Net representations. Once the interactional places are defined, internal places are uniquely determined

The incidence matrix  $\Delta_{q,k-1,l}$  of the WDN  $\Sigma_{qk}$  is defined as follows.  $\Delta_{q,k-1,l}$  is a  $N_l \times M_l$  matrix, where  $k-1 \leq l \leq n$  is the stratum at which the organizational structure of 'q' is described by the matrix. The columns of  $\Delta_{q,k-1,l}$  correspond to the transitions of the net and the rows to the places of the Petri Net representation of the node 'q' in stratum 'l'. The process of folding or unfolding matrices to obtain different strata description of an organizational structure in terms of its incidence matrix description has also been worked out and will be described in the Technical Report.

TABLE 4.2.3 Correspondence Between Matrix and Petri Net Representations

Matrix Representation	Corresponding Input	Transitions Output	Corresponding Place Label
$e_j = 1$	$t_{0qk-1}$	$\rightarrow t_{1ik}$	$P_{1ik}$
$s_i = 1$	$t_{5ik}$	$\rightarrow t_{6qk-1}$	$P_{6ik}$
$F_{ij} = 1$	$t_{1ik}$	$\rightarrow t_{2jk}$	$P_{2ijk}$
$G_{ij} = 1$	$t_{5ik}$	$\rightarrow t_{1jk}$	$P_{6ij1k}$
$H_{ij} = 1$	$t_{5ik}$	$\rightarrow t_{2jk}$	$P_{6ij2k}$
$C_{ij} = 1$	$t_{5ik}$	$\rightarrow t_{4jk}$	$P_{6ij4k}$

### Constraints

A number of *structural* and *user-defined* constraints have already been introduced by Remy (1986) and Demaël (1989). The existing set of constraints fulfills the requirement of an organizational form when defined at the lowest stratum 'N', with DMUs as human decision makers (DMs). The introduction of the stratified organizational forms and the concept of compound node leads to the definition of an extended set of constraints that must be satisfied by the organizational structures defined at stratum 'k', where  $1 \leq k \leq n$  ( $n \leq N$ ). For illustration purposes, two different set of constraints are presented. These two sets of constraints are defined as follows:

- (i) *Global Constraints*: The set of constraints that must be satisfied by all the organizational forms regardless of the stratum for which they are defined.
- (ii) *Compound Node Constraints*: The set of constraints that are defined only for those organizational forms which have compound nodes as DMUs.

These constraints not only eliminate the WDNs that do not represent realistic organizational forms, but also reduce the dimensionality of the design problem. The extended sets of constraints are described as follows.

### Global Constraints

Let  $\Sigma_{qk}$  be an organizational form in stratum 'k' defined for node 'q' in stratum 'k-1'. Then the fixed structure associated with it must satisfy

- (R1) (a) The Ordinary Petri Net that corresponds to  $\Sigma_{qk}$  should be connected, i.e., there should be at least one (undirected) path between any two nodes in the net.  
 (b) A directed path should exist from the source place to every node of the PN and from every node to the sink.
- (R2) The Ordinary Petri Net that corresponds to  $\Sigma_{qk}$  should have no loops. i.e., the structure must be acyclic.
- (R3) In the Ordinary Petri Net that corresponds to  $\Sigma_{qk}$ , there can be at most one link from the RS/RSC stage of a DMU 'i' to another DMU 'j', i.e., for each 'i' and 'j', only one element of the triplet {  $G_{ij}$ ,  $H_{ij}$ ,  $C_{ij}$  } can be non-zero. The analytical expression of this constraint is given as:

$$\forall (i, j) \in [1..|\mu_k|]^2 \quad G_{ij} + H_{ij} + C_{ij} \leq 1 \quad i \neq j$$

- (R4) Information fusion can take place only at the IF/IFC and CI/CIC stages. Consequently, the SA/SAC stage of a DMU can either receive information from the external environment, or a control signal from another DMU. The translation of this constraint into mathematical terms follows:

$$\forall j \in [1..|\mu_k|] \quad e_j + \sum_{i=1}^m G_{ij} \leq 1$$

Constraint R1(a) eliminates any organizational structure that does not represent a single structure. Constraint R1(b) insures that the flow of information is continuous within the organizational structure. It eliminates internal sink or source places. For the kind of organizational structures modeled in this thesis, R1(b) implies R1(a).

Constraint R2 allows acyclical organizational structures only. This restriction is imposed to avoid deadlocks and infinite circulation of messages within the organization (Levis, 1984). Note, however, that constraint R2 does not imply that the graphical representation of the stratified organizational forms is acyclical, because the folding of acyclical nets can yield a structure with loops. The constraint of acyclicity is restricted to the elements of the set of WDN  $W_{qk}$  of a node 'q' in stratum 'k-1' defined in stratum 'k'.

Constraint R3 indicates that it does not make sense to send the same output to the same role at several stages. It is assumed that once the output has been received by a DMU, this output is stored in its internal memory and can be accessed at later stages.

Constraint R4 has to do with the nature of the IF/IFC stage. The IF/IFC stage has been introduced explicitly to perform a fusion between the situation assessments performed by other DMUs. It prevents a DMU from receiving more than one input at the SA/SAC stage (Balbes

and Dwinger, 1974). However, it is possible to circumvent this restriction without increasing the dimensionality of the design problem.

### *Compound Node Constraints*

Let  $\Sigma_{qk}$  be the organizational form in stratum 'k' defined for node 'q' in stratum 'k-1' with DMUs 'i' and 'j' being the compound nodes. Then the fixed structure associated with  $\Sigma_{pk}$ , in addition to the global constraints, must also satisfy the following compound node constraints.

- (C1) In the Ordinary Petri Net that corresponds to  $\Sigma_{qk}$ , there must be an *input link* to the SAC stage of a DMU 'i'. This input link can be an external input or a control signal from another DMU 'j'. The analytical expression of the constraint is given as:

$$\forall j \in [1..|\mu_k|] \quad e_j + \sum_{i=1}^m G_{ij} = 1$$

- (C2) In the Ordinary Petri Net that corresponds to  $\Sigma_{qk}$ , there must be at least one *output link* from the RSC stage of a DMU 'i'. This output link can be an external output or control signal to another DMU 'j', or both. The analytical expression is given as:

$$\forall j \in [1..|\mu_k|] \quad s_j + \sum_{i=1}^m G_{ji} \geq 1$$

Constraint C1 insures an input connection to a compound node DMU. As mentioned earlier, a compound node / DMU has all of its five stages present in an organizational structure. The constraint insures the presence of the SAC stage of a compound node.

Constraint C2 insures an output connection to a compound node DMU. The constraint realizes the presence of the RSC stage of a compound node. Once the SAC and RSC stages are present, all the intermediate stages must also be present, thus satisfying the condition that all the stages should appear in a compound node structure.

The application of constraint R1 on organizational forms with compound nodes as DMUs implies constraints C1 and C2.

### *User-Defined Constraints*

A design procedure should allow the designer of an organization to introduce constraints that reflect specific structural considerations. He may rule in or rule out some links, force a certain pattern of interaction, or express hierarchical echelon type relationship between the DMUs.

These restrictions and specification will be denoted as user-defined constraints. They can be introduced in two different ways.

Constraints  $R_f$ : The designer can place appropriate 0's and 1's in the arrays { e, s, F, G, H, C } defining the WDN.

Constraints  $R_p$ : To accommodate some very special kind of interactions not covered by the arrays mentioned above, the designer of an organization is allowed to introduce *special constraints*,  $R_p$ . The links introduced as special constraints may be the ones that are not covered by the allowable interactions presented

in Figures 4.3 and 4.8. The links, however, are fixed and therefore do not increase the dimensionality of the design problem, rather they introduce some flexibility in the design procedure. The rationale behind the introduction of special constraints is given in Remy (1986). The following restrictions apply to the set of  $R_p$ :

- $i \neq j$  : the two DMUs should be different.
- All those links that can be represented in a WDN should not appear in  $R_p$  except for the case where
  - $s = 5$  and  $r = 1$  : a link between RS/RSC and SA/SAC stages.
  - If  $s = 5$  and  $r = 1, 2, 4$ ; provided that the introduction of these links in WDN violates constraints R3.

In the Petri Net representation, each special constraint will be represented by an interactional place. The labeling of the place will be determined by its input and output transitions as:

$(t_{sik}, t_{rjk})$  will correspond to  $p_{s+1jrk}$ .

**Conflict Among Constraints:** In general, no conflict is allowed between the structural and user-defined constraints.

#### *Convexity of the Constraints*

It was shown by Remy (1986) that the constraints applied to organizational structures with human decision makers as DMUs (global constraints) are not all convex. The problem posed by constraint R1 has been solved by using the concept of *simple paths*. Fortunately, the set of structural constraints for compound node organizations are all convex, as the introduction of constraints C1 and C2 implies R1, and both can be proved convex. The set of *Feasible Organizations* can, therefore, be characterized easily by its minimal and maximal elements for the organizational structures comprised of compound nodes. A Feasible Organization is defined to be an organization that fulfills all the structural and user-defined constraints.

#### *Connectivity Problem*

The problem of interpreting higher level interactions in lower levels arises when an organizational structure is unfolded to its lower level description. It is, therefore, required to formulate a set of connectivity rules that can be used to translate interactions among subsystems of the organization defined at a given level to their lower level representations. The current effort is focused on the formulation of such rules.

#### *Design Algorithm*

Once the connectivity issue is resolved, the integration of the results presented in this report together with the Lattice Algorithm would lead to an algorithmic implementation of the overall design methodology for the hierarchical decision making organizations.

#### **Documentation**

Levis, A. H., "A Colored Petri Net Model of Intelligent Nodes" *Proc. 1991 IMACS Symposium on Modeling and Control of Technological Systems*, Lille, France, May

1991. The paper was also selected to appear in a book by Elsevier - North Holland with selected reprints from several MACS symposia. Book to appear in 1992.

Levis, A. H., "A Colored Petri Net Model of Command and Control Nodes" to appear in *Command, Control, and Communications: Advanced Concepts and Paradigms*, Carl R. Jones, Ed., AIAA Press, Washington DC. Book to appear in late 1992.

The thesis of S. A. Zaidi is in preparation with late November as the targeted completion date.

#### **4.3 GENERAL METHODOLOGY FOR PRESCRIBING TEAM DECISION PROCEDURES.**

**Background** - A team is a well-trained group of decision makers with overlapping areas of expertise. Each team member has an area of responsibility, a set of decision functions for which that team member is responsible, and a protocol for communicating with other team members. Previous work in the mathematical modeling of teams has addressed the problem of specifying organizational structures, but there has been very little work addressing the problem of specifying the procedures embedded in each decision function.

In team decision making, a function corresponds to a set of decision procedures. For instance, a team member may be responsible for the function Interpret-Sensor-Readings, where it is the team member's responsibility to read a set of sensor displays (input) and to report values for Probable-Current-Situation (output). Another team member may be responsible for the function Allocate-Air-Resources, where it is the team member's responsibility to use information about the Probable-Current-Situation to determine how to allocate air resources.

The performance of a team depends on the decision procedures each team member has been trained to execute and how effectively and reliably those procedures are executed. The objective of this research activity is to develop an approach to prescribing a set of decision procedures that (a) will lead to high performance, and (b) team members can reliably execute even under conditions of high stress.

**Progress this period.** Specification of the basic methodology was essentially completed during this period. A paper summarizing this methodology is being prepared. The approach is overviewed below.

**Results** - The methodology we have developed begins by developing a domain model to characterize the set of decision situations a team will face. The domain model is defined as a *probability graph* that characterizes the relationship between different "objects" in the domain. Consider, for instance, a problem where the decision maker must evaluate a radar track to assess whether the incoming aircraft is hostile or friendly. The objects in this domain include the aircraft; the location, speed and heading of the aircraft; the electronic emissions of the aircraft; and the radar system. The probability graph for this problem would state (a) a prior probability that the aircraft is hostile, (b) the probability distribution over location, heading and speed given the aircraft is either hostile or friendly, (c) the probability distribution over emissions given the aircraft is either hostile or friendly, and (d) the probability distribution over different radar readings given different values on (b) and (c). It is not assumed that point values for these probability statements are available.

The domain model can be used to derive an optimal decision procedure. Unfortunately, the optimal procedure would involve complex Bayesian updating which people cannot execute. Therefore, we need to find a set of decision procedures that (a) achieves nearly the same performance level as the optimal procedure and (b) team members can execute reliably even under conditions of high stress.

The domain model can also be used to deduce the distribution of outputs of a proposed set of decision procedures. Consequently, the domain model provides a sufficient basis for predicting the behavior and performance of any proposed set of decision procedures. The domain model can therefore be used to determine if near-optimality has been achieved.

With regard to robustness execution, two issues are considered-- *workload* and *cognitive biases*. Task workload is measured in terms of the number and distribution of decision variables needed to execute the decision procedure. Although the general methodology does not require it, we are currently using the task workload measures defined in Boettcher and Levis (1983) and Andreadakis (1988) and used by Jin (1990). Here we are looking for a decision procedure where task workload is kept small.

Cognitive biases refer to consistent deviation from normative judgments. It is well documented in the behavioral decision theory literature that people employ heuristic procedures to make judgments, and that these heuristic procedures consistently lead to less than optimal judgments. For instance, people often engage in a heuristic called anchoring and adjustment. They anchor on an initial value and adjust their assessment to account for additional information. Often people underestimate the value of the additional information and do not adjust enough. The tendency of people to consistently under adjust on the basis of new information is an example of a cognitive bias. A *vulnerable-to-bias* decision procedure is a decision procedure which provides the opportunity for biases to occur. We expect that vulnerable-to-bias decision procedures are more vulnerable to stress than other decision procedures.

The methodology we have developed looks for decision procedures that are (1) low workload, (2) not vulnerable to biases in key areas, and (3) are near optimal in performance.

#### **Documentation**

Lehner, P. "Towards a theory of team design," *Proceedings of the 1991 Symposium on Command and Control Research*, June 1991, 149-159.

Lehner, P. "Towards a prescriptive theory of team design," *Proceedings of the 1991 IEEE Conference on Systems, Man and Cybernetics*, September 1991, 2029-2034.

#### **4.4 EXPERIMENTAL RESEARCH TO EVALUATE VULNERABLE-TO-BIAS DECISION PROCEDURES**

**Background.** C2 teams are composed of a group of interacting decision makers working cooperatively to solve a common decision problem. Each team member has an area of expertise. Each team member is responsible for a distinct set of inference and decision functions for which each team members is well-trained. Under conditions of low stress, one would expect a well-trained team to reliably execute the procedures they have been taught and to perform well. An open question, however, is the extent to which training breaks down under conditions of high stress. Except for issues related to task workload, this issue has not been addressed.

The objective of this research task is to investigate the impact of cognitive biases on the performance of well trained teams under stress. Our research contrasts two perspectives.

*Perspective 1 (P1)* - Cognitive biases are largely a matter of preference. Although people tend to use heuristic rules that deviate from normative procedures, they can be taught to



reliably use alternative rules, as long as the alternative rules do not exceed bounded rationality constraints.

*Perspective 2 (P2)* - Cognitive biases are largely a matter of capability. Even if trained, people do not reliably execute judgment and decision procedures that do not conform to cognitive biases.

For team decision making under stress, these two perspectives differ considerably with respect to their implication for designing teams. If P1 is correct, then the literature on human cognitive biases is simply irrelevant to the problem of designing teams. Properly trained and practiced teams will reliably execute correct decision procedures until workload or other bounded rationality constraints are exceeded. If P2 is the correct, then cognitive bias considerations should place severe constraints on the design of a team. Specifically, one should avoid specifying team architectures and decision procedures that are inconsistent with the heuristic decision making procedures that people naturally use. Otherwise, these teams will be vulnerable to cognitive biases, and the team's decision procedure will not be executed reliably under high stress conditions.

Several experiments investigating this issue will be performed.

**Progress during this period.** The first experiment was completed during this period. The analysis of the results will be completed during the next period.

#### **Documents**

Lehner, P., Nallappa, B., O'Conner, M., Saks, S. and Mullin, T. "Cognitive Biases and Stress in Team Decision Making: Preliminary Report," *Proceedings of the 1991 BRG Symposium on Command and Control*.

#### **4.5 AUTOMATED TOOLS FOR SPECIFYING DECISION PROCEDURES.**

**Background** As noted above, a domain model can be used to quantitatively evaluate a proposed set of team decision procedures. If necessary, this can be done manually using general purpose software for processing influence diagrams. However, this is an time consuming process, and there is no guarantee that near optimal decision procedures have been produced.

The objective of this task is to develop automated tools to *derive* team decision procedures from a domain model. The input to the tool will be a domain model and a proposed team architecture. The proposed architecture includes both the number of team members and the types of information flows among team members. The automated tools will tradeoff several factors in the specification of these procedures. These factors include expected performance, workload and cognitive biases.

**Progress this period.** We have acquired a software tool called IDEAL (INfluence Diagram Evaluation and AnaLysis) which provides the necessary functions for defining and exercising domain models. We have also identified specific procedures for evaluating a proposed set of decision procedures. Specifically, if we let  $\{hi\}$  be a set of possible hypothesis states, and  $\{di\}$  a set of possible outputs from a decision procedure, then the key problem is to derive the distribution  $P(\{di|\{hi\})$ . This is the distribution of outputs of the decision procedure given alternative hypothesis values. As it turns out

$$\begin{aligned}
P(d_j|h_i) &= \sum_{e_k} P(d_j|e_k \& h_i) P(e_k|h_i) \\
&= \sum_{\{e_k | D_i - d_j\}} P(e_k|h_i).
\end{aligned}
\tag{Eq. 1}$$

That is  $P(d_j|h_i)$  is equal to the sum of  $P(e_k|h_i)$  for all evidential states  $e_k$  where  $D_i - d_j$ . For small probability networks, these values can be calculated exactly using exact Bayesian update procedures. However, for large and realistic problems  $P(\{d_i\}|\{h_i\})$  can be approximated using a forward simulation monte carlo procedure. This procedure will be implemented during the next period.

### **Documentation.**

Lehner, P. and Sadigh, A. "Reasoning under uncertainty: Some monte carlo results," in *Uncertainty in Artificial Intelligence: Proceedings of the Seventh Conference (1991)*, San Mateo: Morgan Kaufmann Publishers, 1991, 205-211.

## **5.0 MEETINGS**

In September, Dr. Lehner and Dr. Levis presented papers at the 1991 IEEE Conference on Systems, Man and Cybernetics at the University of Virginia.

In July, Dr. Lehner presented a paper at the 1991 Conference on Uncertainty in Artificial Intelligence at UCLA, and then attended the 1991 National Conference on Artificial Intelligence in Anaheim, California.

## **6.0 RESEARCH PERSONNEL**

### **6.1 Current Research Personnel**

The following people are currently participating in this effort.

Prof Paul Lehner	GMU - Principal Investigator
Prof. Alexander H. Levis,	GMU
Dr. Michael O'Conner	DSC - P.I. of subcontract
Mr. Mir-Masood Seyed-Solorforough	GMU - Graduate Research Assistant (Ph.D.)
Mr. Syed Abbas K. Zaidi	GMU - Graduate Research Assistant (MS)
Mr. Zhuo Lu	GMU - Graduate Research Assistant (MS)
Mr. Steve Saks	DSC - Programmer
Mr. Bill Roman	DSC - Programmer

### **6.2 Previous Research Personnel**

The following persons were previously supported by the research effort.

Mr. Bhashyam Nallappa	GMU - Graduate Research Assistant (M.S.)
Ms. Azar Sadigh	GMU - Undergraduate Research Assistant (BS)
Dr. Kent Hull	DSC

Dr. Martin Tolcott  
Dr. Theresa Mullin

DSC - Consultant  
DSC

Dr. Michael Donnell

Consultant

### 6.3 Personnel Changes

As mentioned in previous progress reports, there has been a substantial turnover in personnel at DSC. Dr. Kent Hull was previously replaced by Dr. Michael O'Conner as the DSC project manager. Dr. Tolcott was participating as a consultant to DSC. He is no longer working on this effort. Dr. Mullin was a principal contributor to the design of the first experiment, but was reassigned by DSC. She is no longer working on this effort.

Currently, Dr. O'Conner remains the project manager at DSC. His efforts are now directed toward supporting the design of the second experiment. Mr. Steve Saks and Mr. Bill Roman have been directed to support the design and implementation of a new experimental testbed.

Also Mr. Bhashyam Nallappa, a GMU graduate research assistant, is no longer participating on this effort.

## 7.0 DOCUMENTATION

### 7.1 Theses

1. MS Thesis by Syed A. Zaidi in preparation - due November 1991.
2. MS Thesis by Z. Lu in preparation - due April 1992.

### 7.2 Technical Papers

1. Lehner, P., Nallappa, B., O'Conner, M., Saks, S. and Mullin, T. "Cognitive Biases and Stress in Team Decision Making: Preliminary Report," *Proceedings of the 1991 BRG Symposium on Command and Control*.
2. Lehner, P. "Towards a Theory of Team Design," *Proceedings of the 1991 Symposium on Command and Control Research*, June 1991, 149-159.
3. Lehner, P. "Towards a Prescriptive Theory of Team Design," *Proc. 1991 IEEE International Conference on Systems, Man and Cybernetics*, October 1991, 2029-2034.
4. Lehner, P. and Sadigh, A. "Reasoning under Uncertainty: Some Monte Carlo Results," in *Uncertainty in Artificial Intelligence: Proceedings of the Seventh Conference (1991)*, San Mateo: Morgan Kaufmann Publishers, 1991, 205-211.
5. Levis, A. H., "A Colored Petri Net Model of Intelligent Nodes" *Proc. 1991 IMACS Symposium on Modeling and Control of Technological Systems*, Lille, France, May 1991.
6. Levis, A. H., "A Colored Petri Net Model of Command and Control Nodes" to appear in *Command, Control, and Communications: Advanced Concepts and Paradigms*, Carl R. Jones, Ed., AIAA Press, Washington DC. Book to appear in late 1992.

7. Lu, Zhuo and A. H. Levis, "A Colored Petri Net Model of Tactical Decision Making," *Proc. 1991 Symposium on C2 Research*, National Defense University, Ft. McNair, Washington, DC, June 1991.
8. Lu, Zhuo and A. H. Levis, "A Colored Petri Net Model of Distributed Tactical Decision Making," to appear in *Proc. 1991 IEEE International Conference on Systems, Man, and Cybernetics*, October 1991.

## 8. REFERENCES

- Andreadakis, S.K. (1988) "Analysis and Synthesis of Decision Making Organizations" LIDS-TH-1740, Ph.d. Thesis, Laboratory for Information and Decision Systems, MIT, Cambridge, MA.
- Balbes, R. and Dwinger, P. (1974). *Distributive Lattices* University of Missouri Press, Columbia, Missouri.
- Boetcher, K., and Levis, A.H., (1982) "Modeling the Interacting Decisionmaker with Bounded Rationality," *IEEE Transactions on Systems, Man, and Cybernetics*, SMC-12(3), 334-344.
- Demaël, J. J (1989). "On the Generation of Variable Structure Distributed Architectures." LIDS-TH-1869, Laboratory for Information and Decision Systems, MIT, Cambridge, MA.
- Genrich, H. and Lautenbach, K. (1981) "Systems Modeling with High-Level Petri Nets." *Theoretical Computer Science*, No.13, pp.109-136.
- Jensen, K. (1987). "Colored Petri Nets" in *Advanced Course on Petri Nets 1986, Lecture Notes in Computer Science*, Springer-Verlag, Berlin, Germany.
- Jin, V. Y. (1990) "Effect of Organizational Structure on Performance of Decision Making Teams," LIDS-TH-1976, Ph.D. Thesis, Laboratory for Information and Decision Systems, MIT, Cambridge, MA.
- Levis, A. H. (to appear in 1992). "Modeling and Design of Distributed Intelligence Systems" in *Introduction to Autonomous and Intelligent Control*, P. J. Antsaklis and K. M. Passino, Eds., Kluwer Publishers, Boston, MA.
- Mesarovic, M. D., Macko, D., and Takahara, Y. (1970). *Theory of Hierarchical, Multilevel Systems*. Academic Press, New York.
- Monguillet, J.-M., and Levis A. H. (1988). "Modeling and Evaluation of Variable Structure Command and Control Organizations." *Proc.1988 Symposium on Command and Control Research*. Science Applications International Corporation, McLean, Virginia.
- Remy, P. (1986). "On the Generation of Organizational Architectures Using Petri Nets." LIDS-TH-1630, Laboratory for Information Decision Systems, MIT, Cambridge, MA.
- Remy, P. and Levis, A. H. (1988). "On the Generation of Organizational Architectures Using Petri Nets." in *Advances in Petri Nets 1988, Lecture Notes in Computer Science*, G.Rozenberg Ed. Springer-Verlag, Berlin, Germany.