

AD-A 248 328

WL-TM-90-326-FIBE

HEATING FIXTURE AND
INSTRUMENTATION DESIGN FOR
ELEVATED TEMPERATURE TESTS OF A
COMPOSITE REPAIR TECHNIQUE

LARRY BATES
DONALD COOK



DECEMBER 1991

Approved for public release; distribution unlimited.

FLIGHT DYNAMICS DIRECTORATE
WRIGHT LABORATORY
AIR FORCE SYSTEMS COMMAND
WRIGHT-PATTERSON AFB, OHIO 45433-6553

20060921015

FOREWORD

This report describes an in-house effort conducted under Work Unit 24010366 "Composite Bolted Repair Test Program".

The work was performed by the Structural Integrity Branch, Structures Division, Flight Dynamics Directorate, Wright Laboratory (WL/FIBE), Wright-Patterson Air Force Base, Ohio. The period covered by the research is January 1989 through September 1989.

The in-house effort was conducted by Mr Larry Bates and Mr Donald Cook in continuation of support of the program developed under contract by McDonnell Douglas.

Acknowledgement is due to the members of the FIBT Data Acquisition Control Group and Instrumentation Group for their suggestions and support work.

This technical memorandum has been received and is approved for publication.



JOHN K. RYDER, Capt, USAF
Technical Manager
Fatigue, Fracture and Reliability Group
Structural Integrity Branch

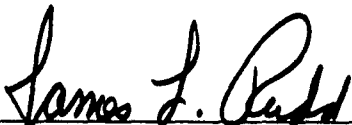

JAMES L. RUDD
Chief, Structural Integrity Branch
Structures Division

ABSTRACT

Static tension tests were conducted for the Structural Concepts Branch (WL/FIBC) on composite bolted repair samples. The purpose of these tests was to compare experimental results with strains predicted by the Composite Bolted Repair Analysis program. This program was originally developed under contract by McDonnell Douglas to predict elevated temperature (0-250°F) strains, but these strains were not confirmed experimentally. Ten panels, 12 inches x 22 inches, were made from AS4/3501 graphite/epoxy. Five panels were laid up as $(\pm 45, 0, 90)_{3S}$ and five panels were laid up as $[(\pm 45, 0, 90)_2(\pm 45, 90_2)]_S$. Each ply was approximately 0.005 inch thick for a total panel thickness of 0.120 inch. For more details about the panels and the entire test program, refer to the WL Technical Report being written by Mr Forrest Sandow of Wright Laboratory Structural Concepts Branch (WL/FIBC). This TM addresses only the oven and instrumentation designs. The oven was designed to be integrated into FIBEC's 100 Kip Instron static test frame and meet the environmental requirements specified by FIBC. The instrumentation included five thermocouples to confirm the specimens were in the required environment, twenty-seven strain gauge channels to measure the strains, and one load cell channel ranging from five thousand pounds to fifty-thousand pounds.

TABLE OF CONTENTS

<u>SECTION</u>	<u>PAGE</u>
LIST OF ILLUSTRATIONS	ii
NOMENCLATURE	iii
I. INTRODUCTION	1
II. HEATING, OVEN DESIGN	6
III. TEST FIXTURE DESIGN	10
IV. INSTRUMENTATION	13
V. TEST RESULTS	18
VI. CONCLUSIONS	24

LIST OF ILLUSTRATIONS

<u>Figure</u>	<u>Title</u>	<u>Page</u>
1.	Panel Design	3
2.	Patch Circular Hole	4
3.	Patch for Elliptical Hole	5
4.	External View of Clamshell Oven	7
5.	Internal View of Clamshell Oven	9
6.	Fixture Design	11
7.	Fixture Dimensions	12
8.	Gage Location for Baseline Panels	14
9.	Gage Location for Patched Panels	15
10.	Load vs Strain Data for Baseline	16
11.	Load vs Strain Data for Baseline (continued)	17
12.	Load vs Strain Data for ACR Unpatched Panel at Room Temperature	20
13.	Load vs Strain Data for ACR Patched Panel at Room Temperature	21
14.	Load vs Strain Data for ACR Patched Panel at 150°	22
15.	Load vs Strain Data for Patched Panel at 250°F	23

NOMENCLATURE

Baseline Panel

Uncut Panel (No holes, no patches)

Patched Panel

Panel With Holes Patched

Unpatched Panel

Panel With Open Holes

I. INTRODUCTION

The Fatigue, Fracture and Reliability Group (WL/FIBEC) test program required the design and fabrication of an oven to heat the test section of patched and unpatched composite panels. The oven had to fit into FIBEC's 100 Kip Instron static test machine. Height and width requirements had to be considered since the available space in the test machine does not allow more than thirty-three inches for placement of oven, loading fixture and panel between machine grips, and twenty-eight inches between test machine columns. The panels were twelve inches wide by twenty-two inches long. A clam-shell oven was designed to allow easy insertion and removal of these large panels and to accommodate the required instrumentation. Panel heating was achieved by using quartz lamps.

The loading fixture and the test panel fit between the grips of the machine. The holes in the test panels were matched drilled to the fixture holes. This allowed a uniform load distribution across the total width of the panels. Drawings of the patched and unpatched test panels are shown in Figures 1-3.

Instrumentation involved interfacing amplifiers, signal conditioners, interface boards, and a real-time processor to the strain gages, thermocouples, and load cell. Data were collected and sent to the mainframe computer for processing. These data were analyzed, plotted, and found to be satisfactory by the technicians and project engineer.

A thermocouple survey was performed to verify uniform temperatures (see Figure 5).

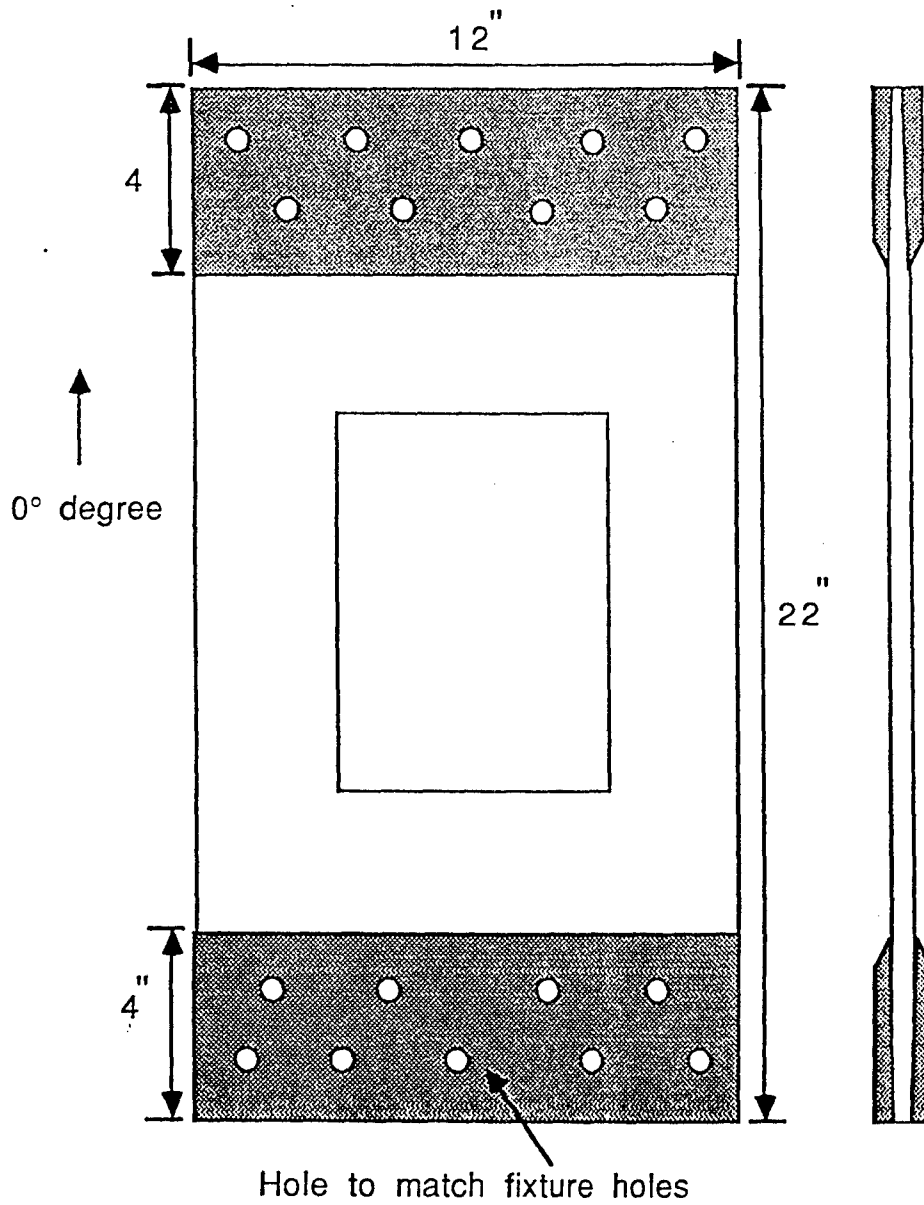

Figure 1. Panel Design

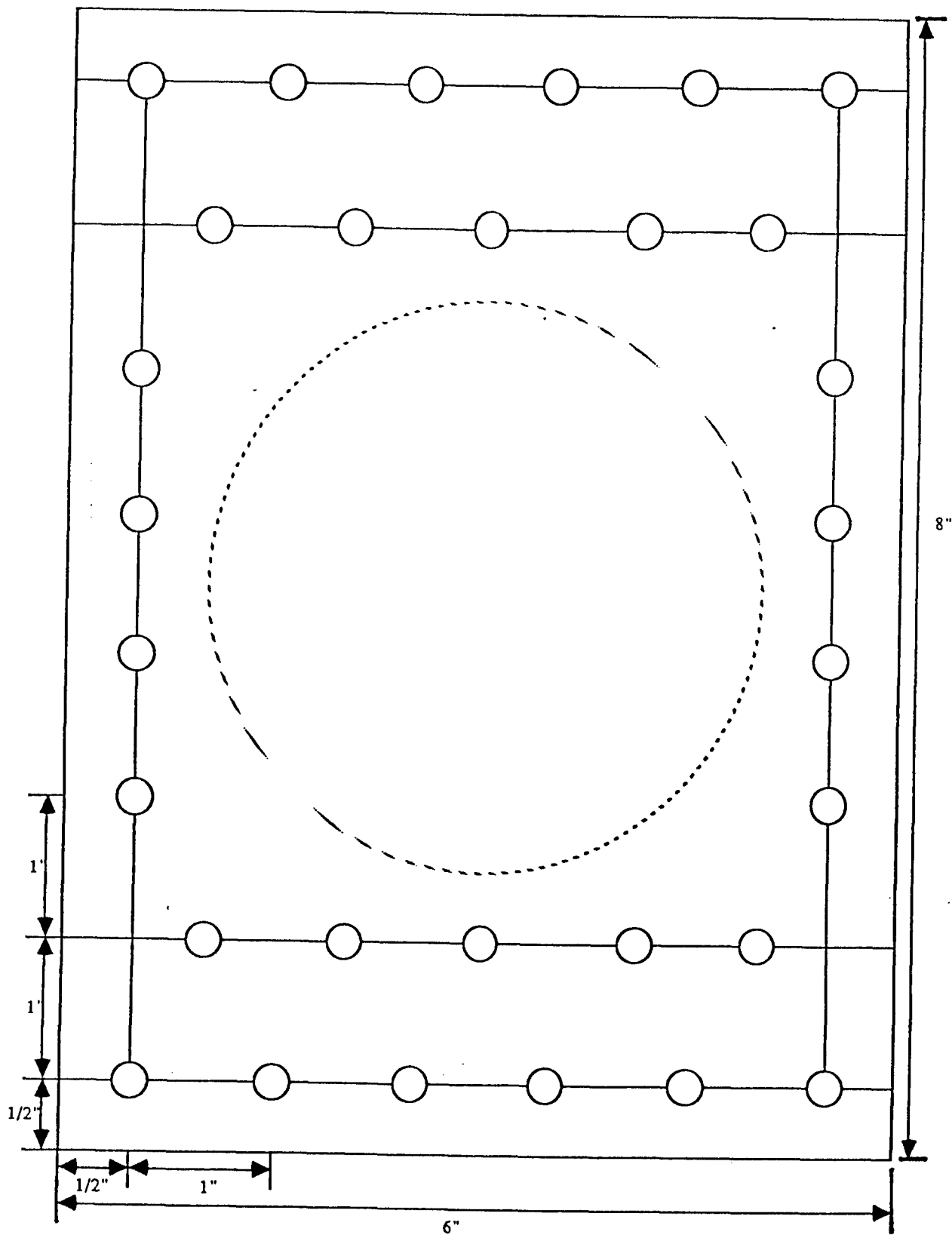

Figure 2. Patch for Circular Hole

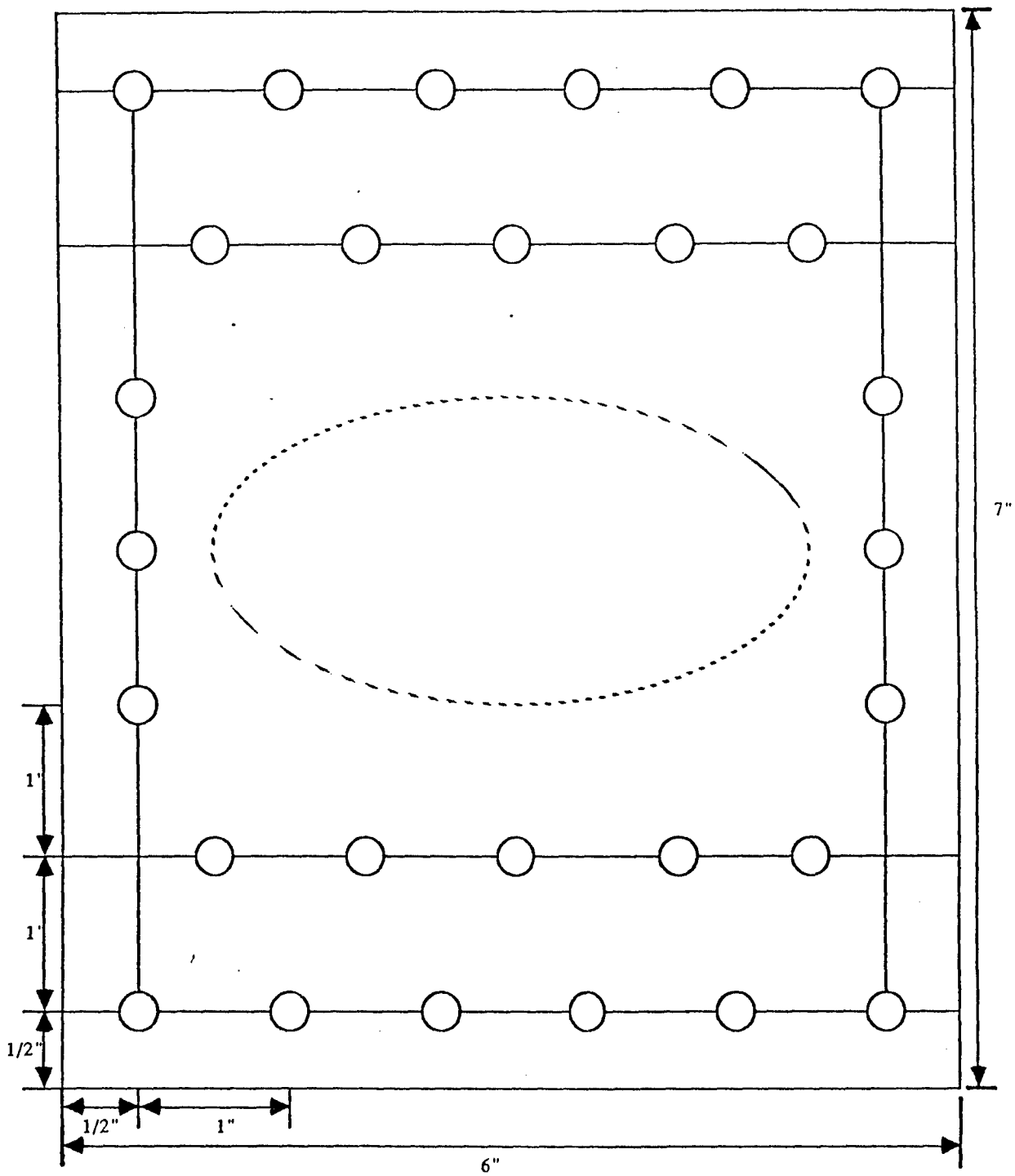

Figure 3. Patch for Elliptical Hole

II. HEATING OVEN DESIGN

This test program required an oven design that was not commercially available. Therefore, information was gathered on temperature profiles, heating elements, electrical requirements, accessibility, etc. Once this information was collected from the Electrical Engineering Group of the Structures Test Branch (WL/FIBT), the final oven design was made by the Fatigue, Fracture and Reliability Group (WL/FIBEC).

The final design was a clam-shell oven. This design allowed easy access for insertion of the specimen and instrumentation. Aluminum was used to fabricate the oven because of its light weight, weldability, resistance to moderately high temperatures, and availability. Due to the space limitations discussed in the Introduction, each half of the clam-shell oven was designed to measure 13 inches wide by 13.25 inches high by 6 inches deep. When both sides were joined by a piano hinge, the oven completely encompassed the 12 inch x 14 inch test section of the specimen. The oven was attached to a one inch diameter steel pipe with support legs to allow height adjustments (see Figure 4).

The electrical design for the oven utilized T3 radiant tungsten filament quartz lamps because they were the lowest wattage lamps available in-house. Through experimentation, the choice of five equally spaced lamps provided enough heat to reach the required temperatures (150°F, 250°F). The lamps were placed 2.5 inches from the specimen surface. Ceramic stand-



Figure 4. External View of Clamshell Oven

offs were used to isolate the electrical lamp circuit from the aluminum oven casing. The lamps were wired in series to prevent the controller system from being overdriven. High temperature wiring had to be used to withstand the elevated temperatures. A controller rated at thirty amps was chosen for temperature control.

Gold plated stainless steel reflectors were used under the lamps to reflect radiant heat toward the specimen. The 0.0002 inch gold plating reflector was chosen because gold reflects best at high temperature.

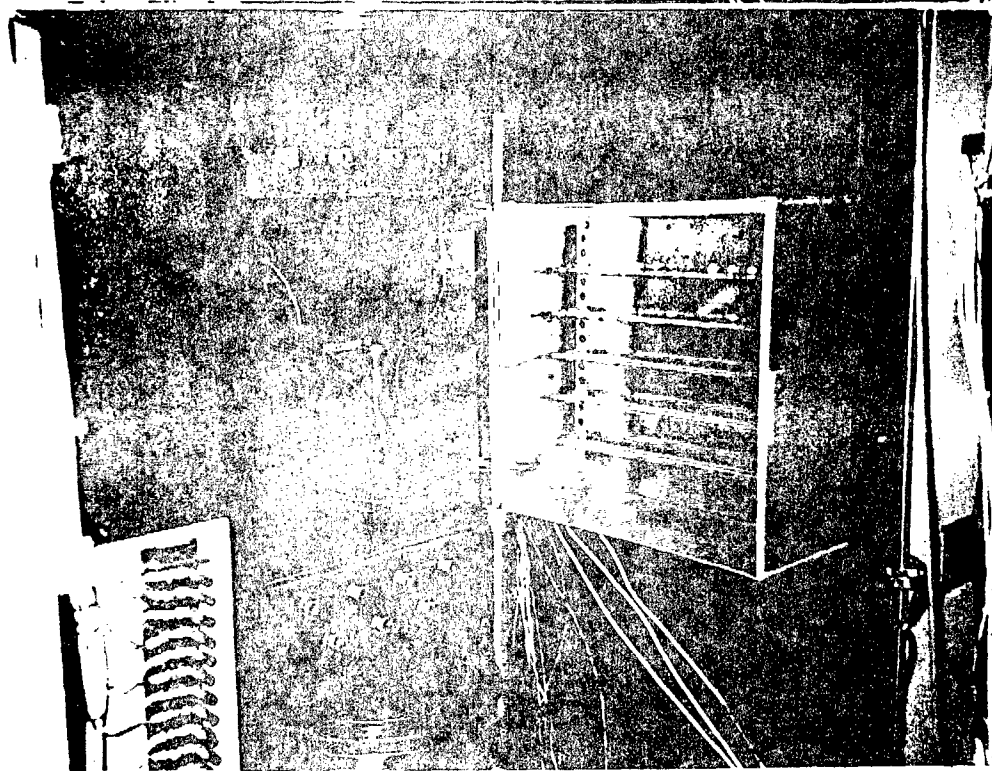

Figure 5. Internal View of Clamshell Oven

III. TEST FIXTURE DESIGN

A loading fixture was designed to introduce uniform strains across the 12 inch width of the panels. The fixture was also designed to be compatible with the test machine's hydraulic grips and compact enough to allow the panels and fixture to fit between the grips of the test machine. The loading fixture details are shown in Figures 6 and 7.

High strength 4340 steel, with 150 KSI treatment, was used in fabricating four fixtures having dimensions of 1/2 inch thick, 12 inches wide and 8 inches long. It was determined nine holes had to be drilled to provide equal strain across the panels. For further details of the fixture, see Figure 5.

One phase in the program was to ensure the baseline panels had uniform states of stress from the loading transferred to them by the fixture. The panels were tested at 5, 10, 15 and 20 Kip loads at room temperature, 150°F, and 250°F to confirm the state of stress.

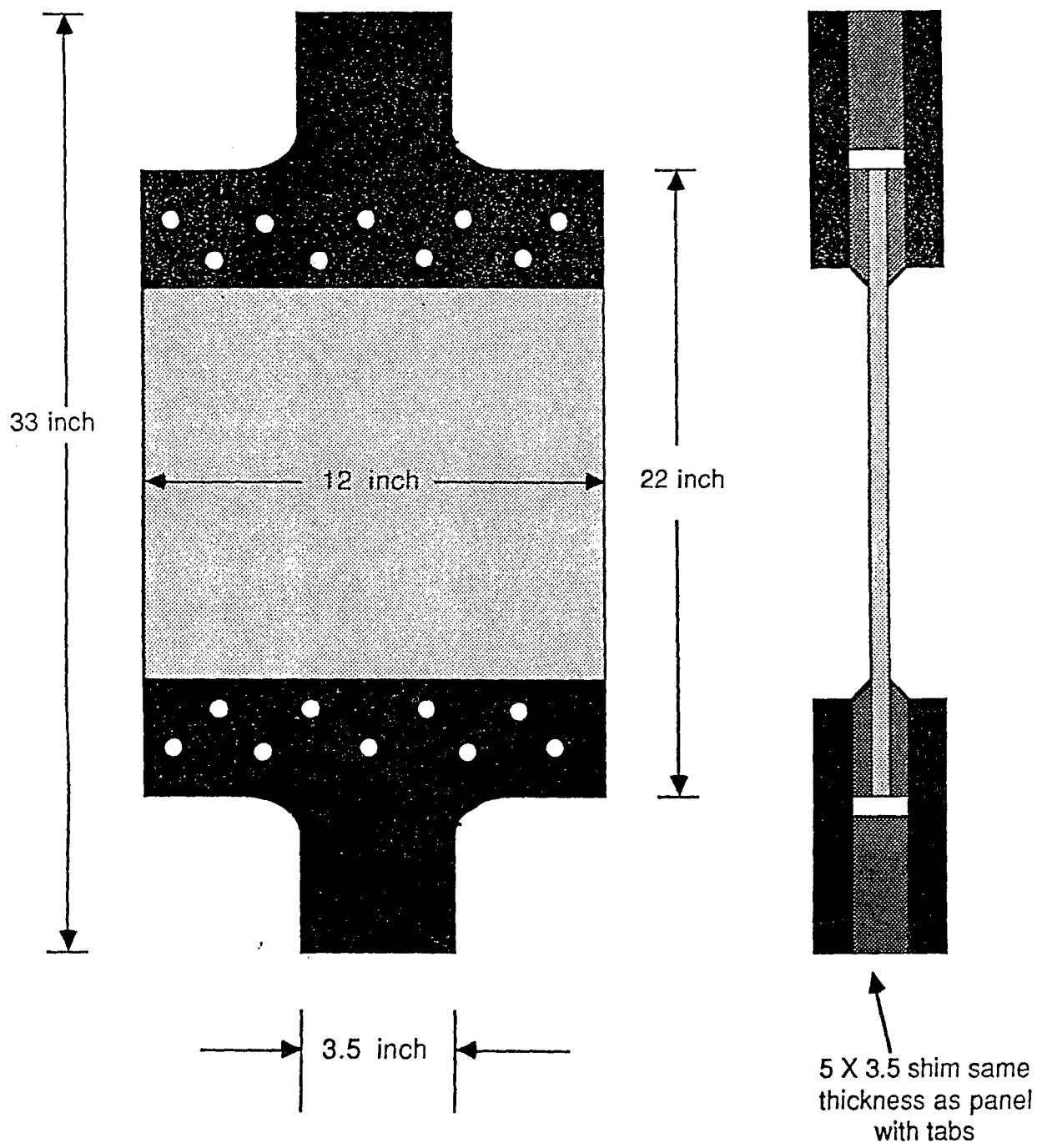

Figure 6. Fixture Design

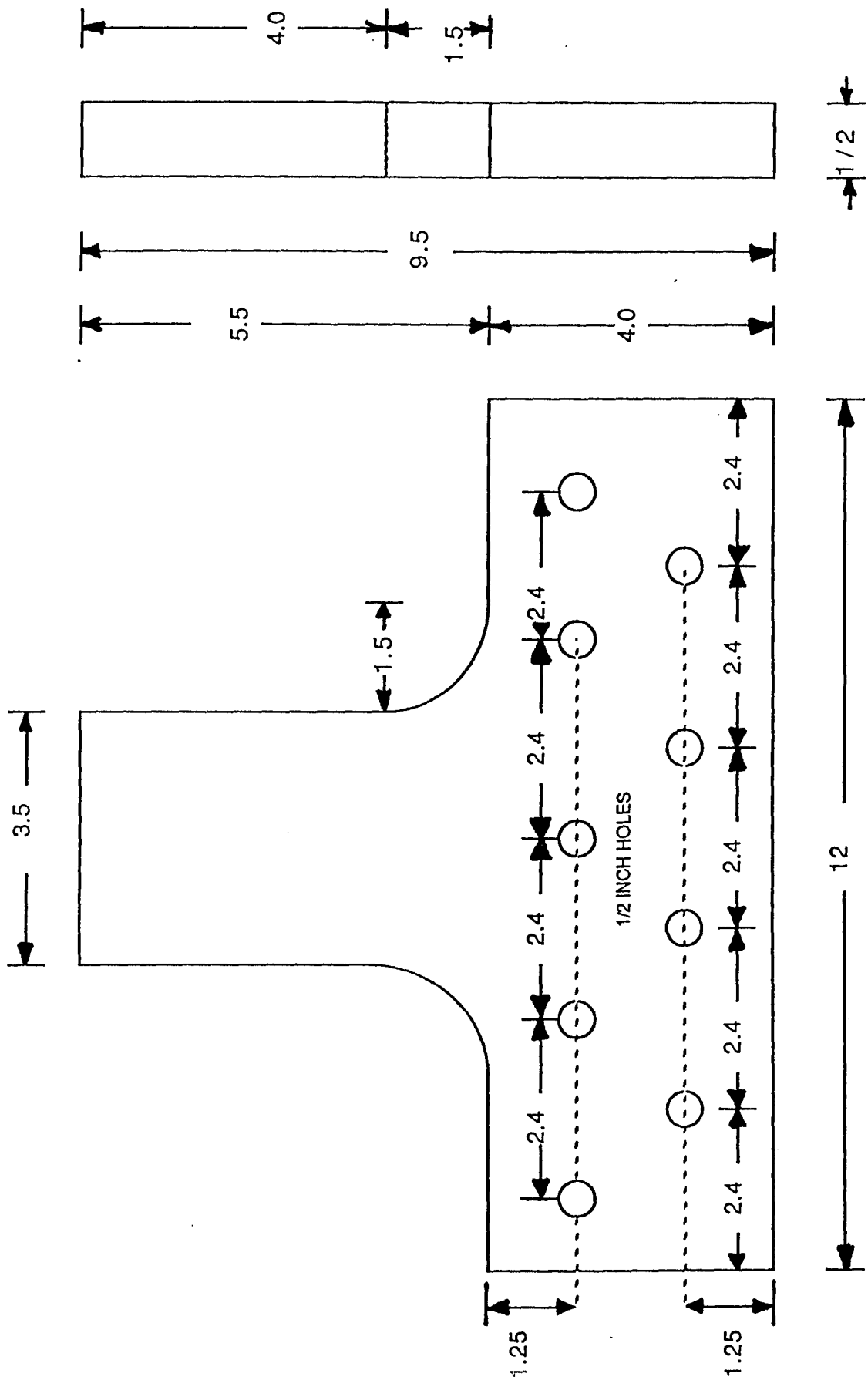

Figure 7. Final Fixture Dimensions

IV. INSTRUMENTATION

Instrumentation requirements for the test program included thirty-six strain channels, five thermocouple channels, and one load cell channel. Since the Fatigue, Fracture and Reliability Group's (WL/FIBEC) data system would handle only thirteen strain channels and one load cell channel, the system had to be significantly modified.

The Data Acquisition Control Group of the Structures Test Branch (WL/FIBT) supplied the necessary equipment. This included an Analog to Digital converter - multiplexer with 128 available channels, a large network of new cables, thirty-six strain gage conditioners, a thirty-six channel interface strain gage board modified for a three-wire hook-up for the reduction in desensitizer error, a five channel readout to monitor thermocouples and a new multiplexer I/O line to the VAX computer for the collection and analysis of the data.

Figure 8 shows the gage locations for the baseline panels A1 and B1 at room temperature. Figure 9 displays gage locations for the patched panels which were tested at room and elevated temperatures.

As a result of this effort, ten panels were successfully tested. The five thermocouples monitored the temperature of each specimen and the thirty-six strain channels and one load cell accurately measured the strain and load.

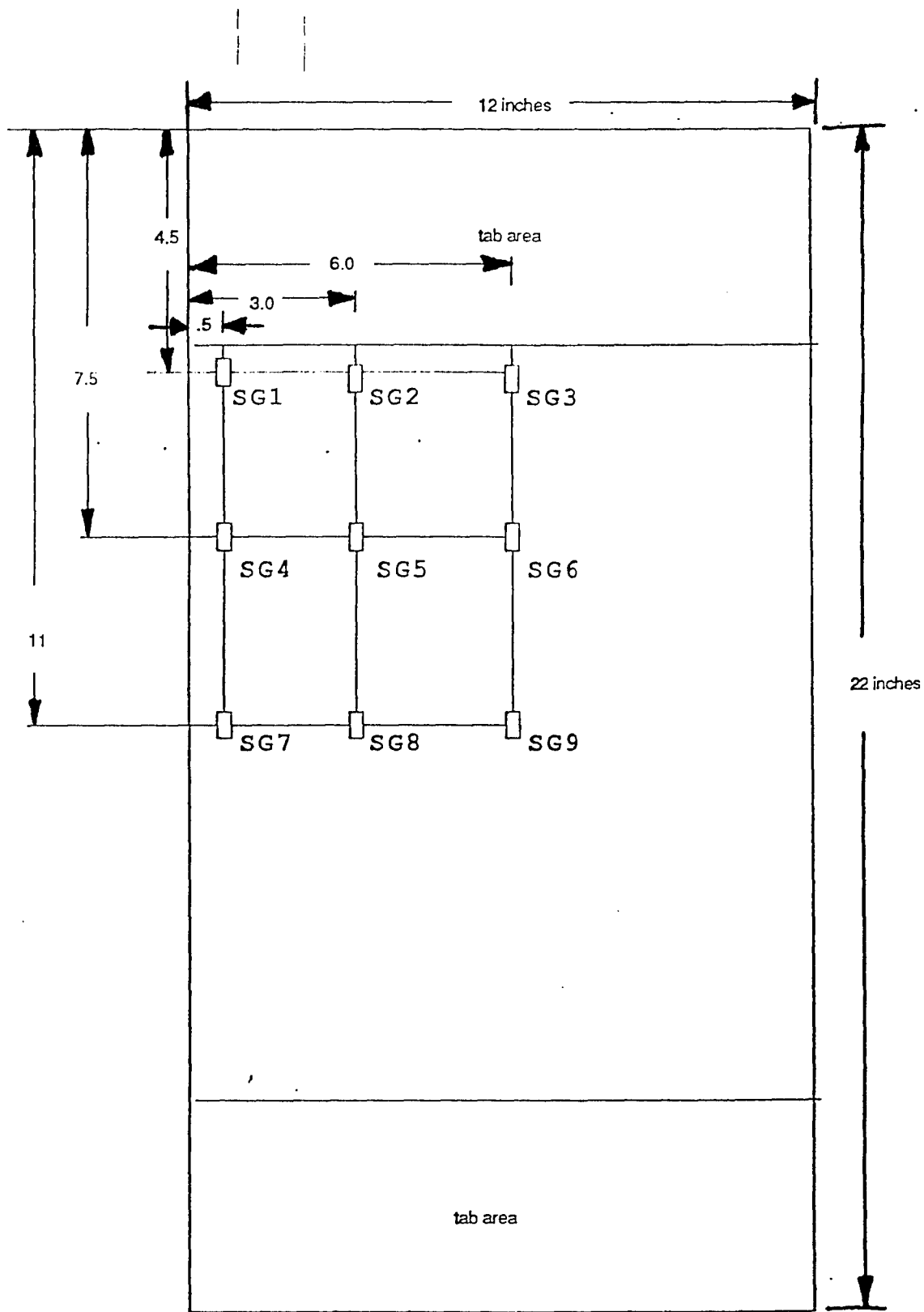

Figure 8. Gage Locations for Baseline Panels A1 and B1

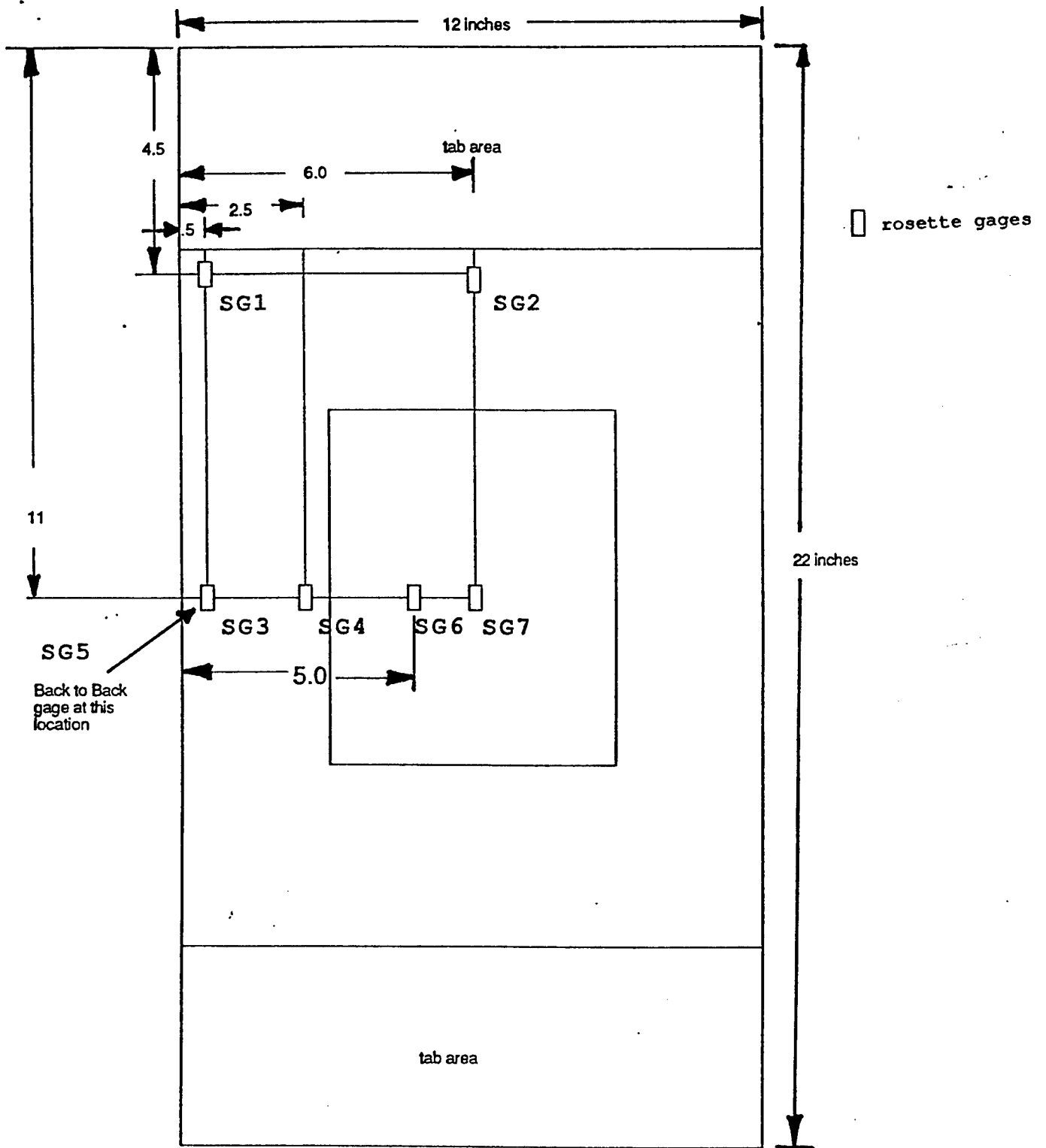

Figure 9. Gage Locations for Patched Panels

Uniform Strain Survey Test

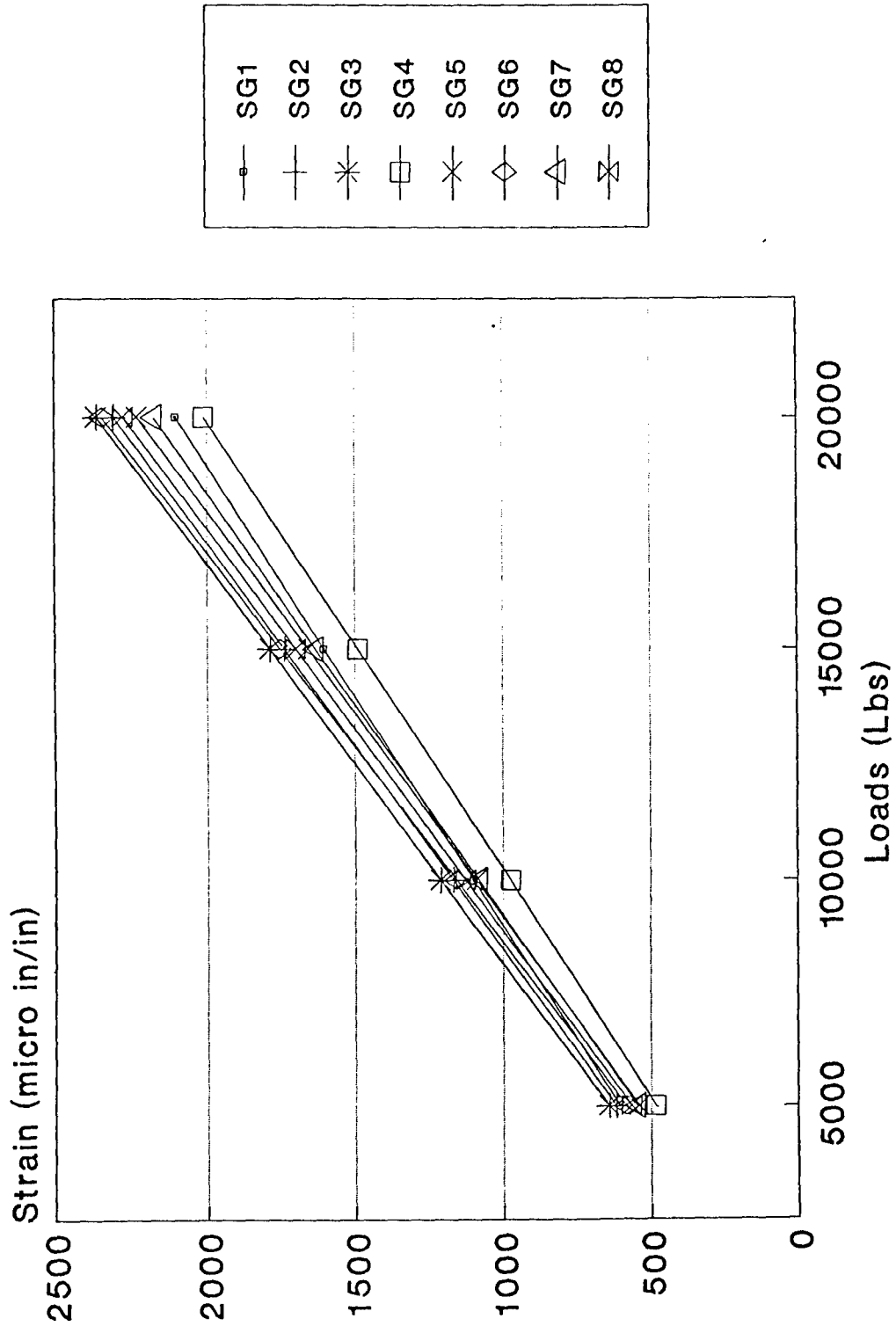

Figure 10

Uniform Strain Survey Test

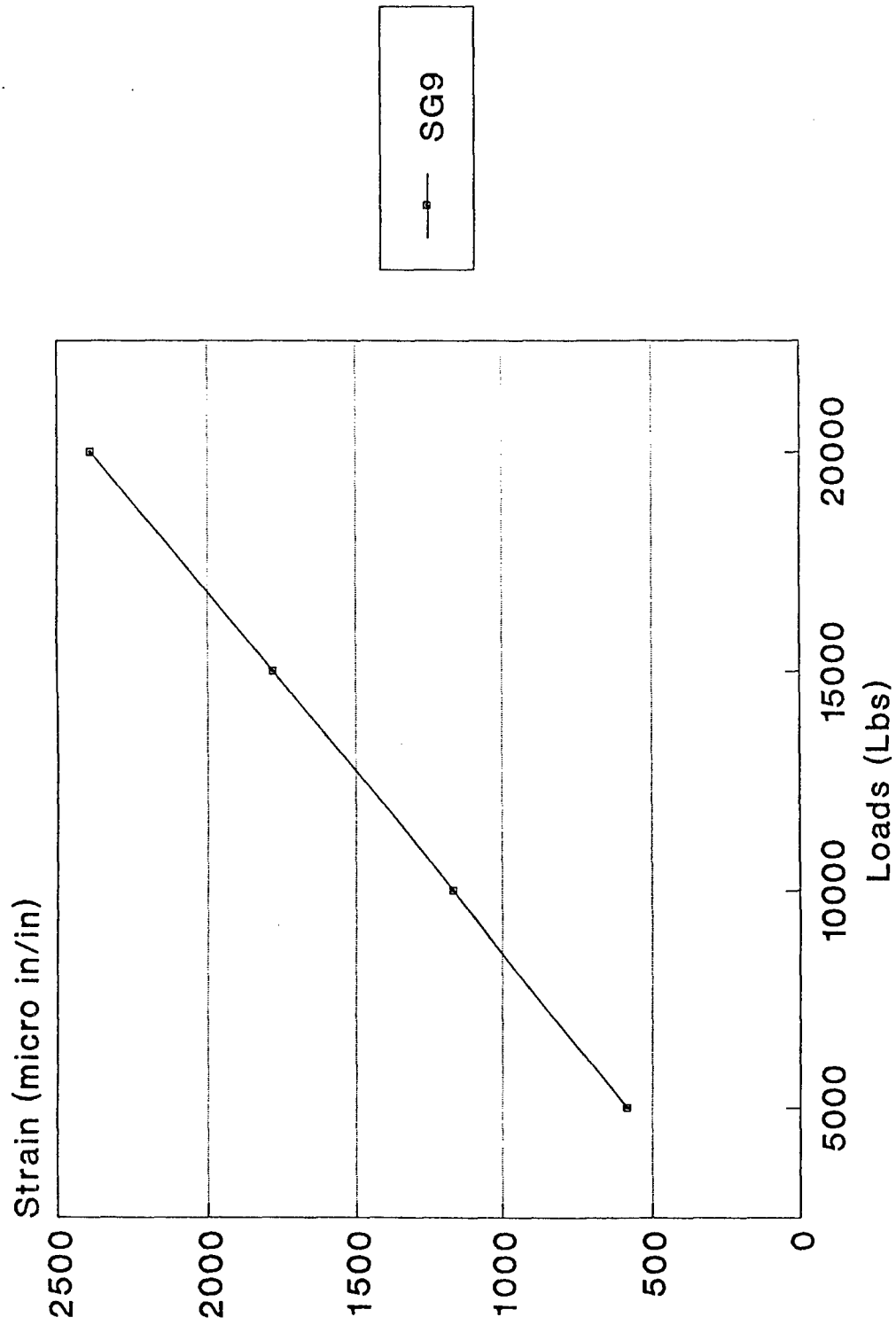

Figure 11

V. TEST PROCEDURES AND RESULTS

The test plan for the panels started with preliminary testing of uncut panels to generate baseline data. The strains in the baseline panels were measured at loads of 5, 10, 15 and 20 Kips at room temperature, 150°F, and 250°F. The panels were then patched with composite-lock fasteners and metal patches by FIBC. Strain measurements were repeated at the same three temperature and load levels for the panels with patches.

Data collection was accomplished by interfacing strain gage and load cell multiplexing units with the VAX computer. Strain surveys were performed on uncut panels to ensure uniform strain across the width of the panels. Plots of these surveys confirmed the presence of uniform strain and were used by the technicians in their decision to continue testing and should probably show plot of strain survey from baseline panel showing uniform strain across the panel width.

An example of the strain measurements is shown in Figure 12 for panel ACR, unpatched. As expected, SG4 which was closest to the hole, recorded the highest strain measurements from the stress concentration.

Figure 13 shows the strain in a patched ACR panel at room temperature. A reduction in strain in SG4, as compared to the unpatched panels, implies that the patch was effective. SG1 and SG2 showed high strain levels because they were located in a panel section with a smaller cross-sectional area. Differences in SG3 and SG5, which are back to back, show some

buckling of the panel due to the nonsymmetric loading caused by the high stiffness of the patch. Gages SG6 and SG7 do not see any effect of loading until 5 Kips is reached. Figures 14 and 15 show the same kind of information at other temperature levels.

Comparisons between these results and the predictions of the Composite Bolted Repair Analysis program are discussed further in the final technical report written by Mr Forrest Sandow of the Structural Survivability/Supportability Group (WL/FIBCA).

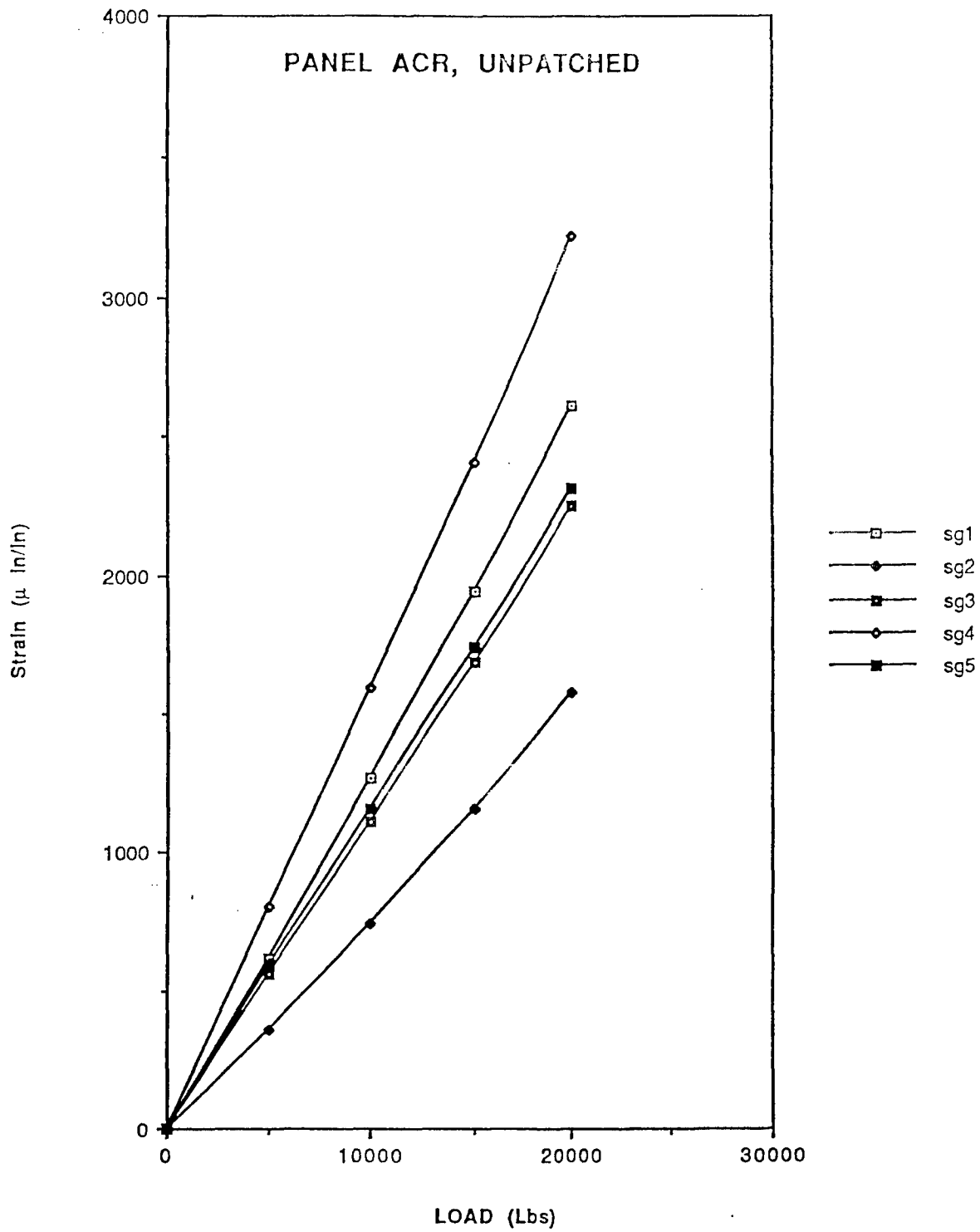

Figure 12

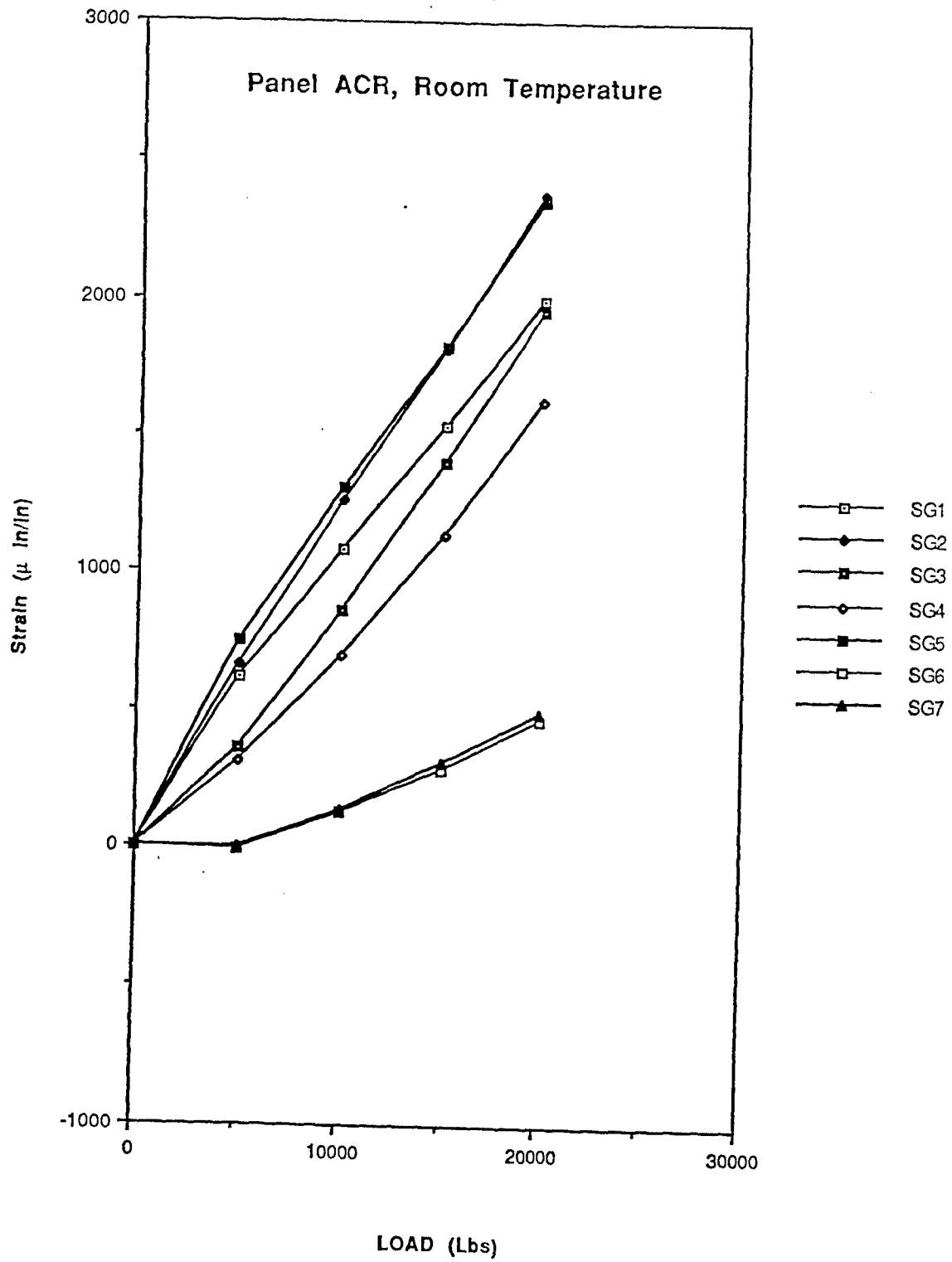

Figure 13

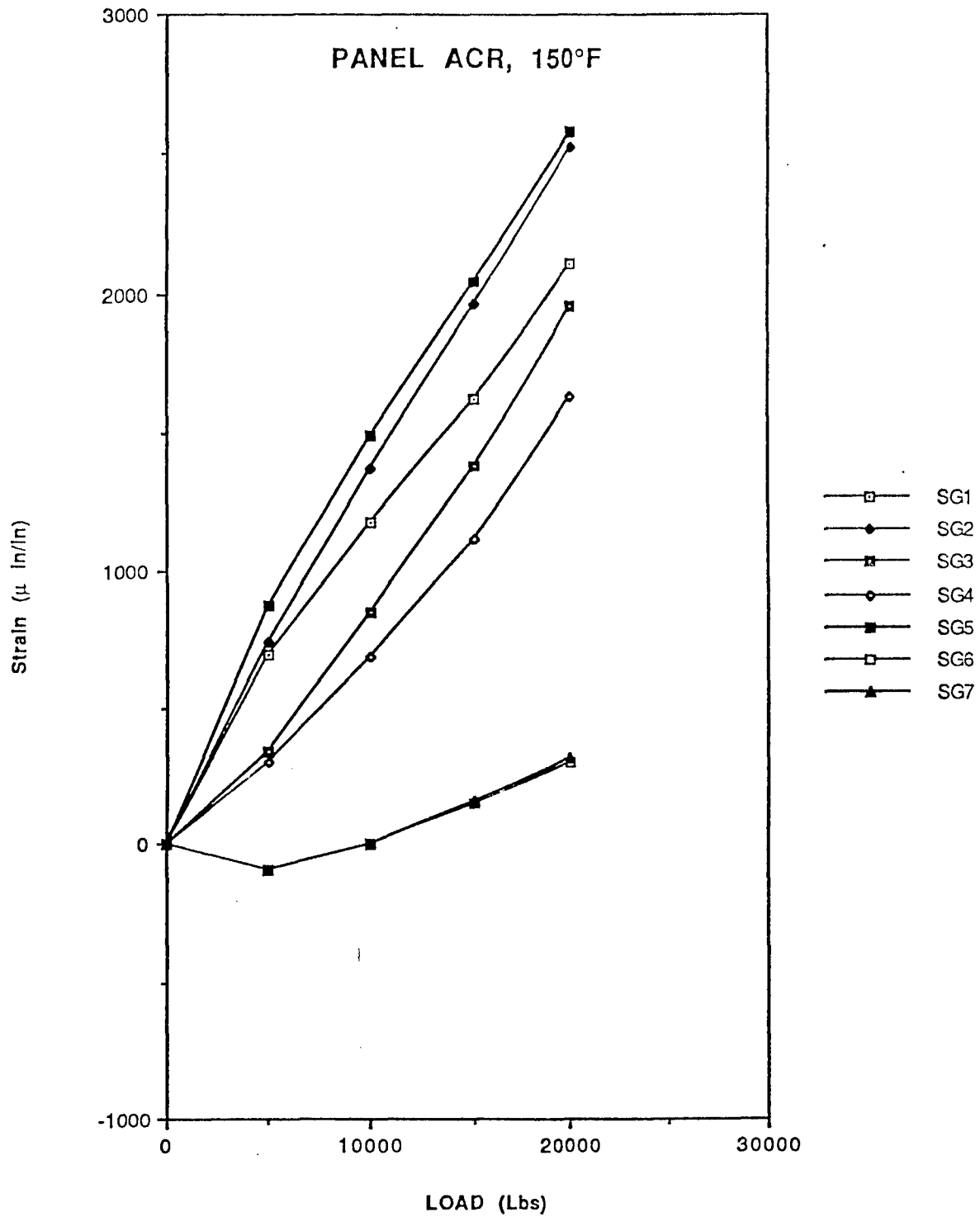

Figure 14

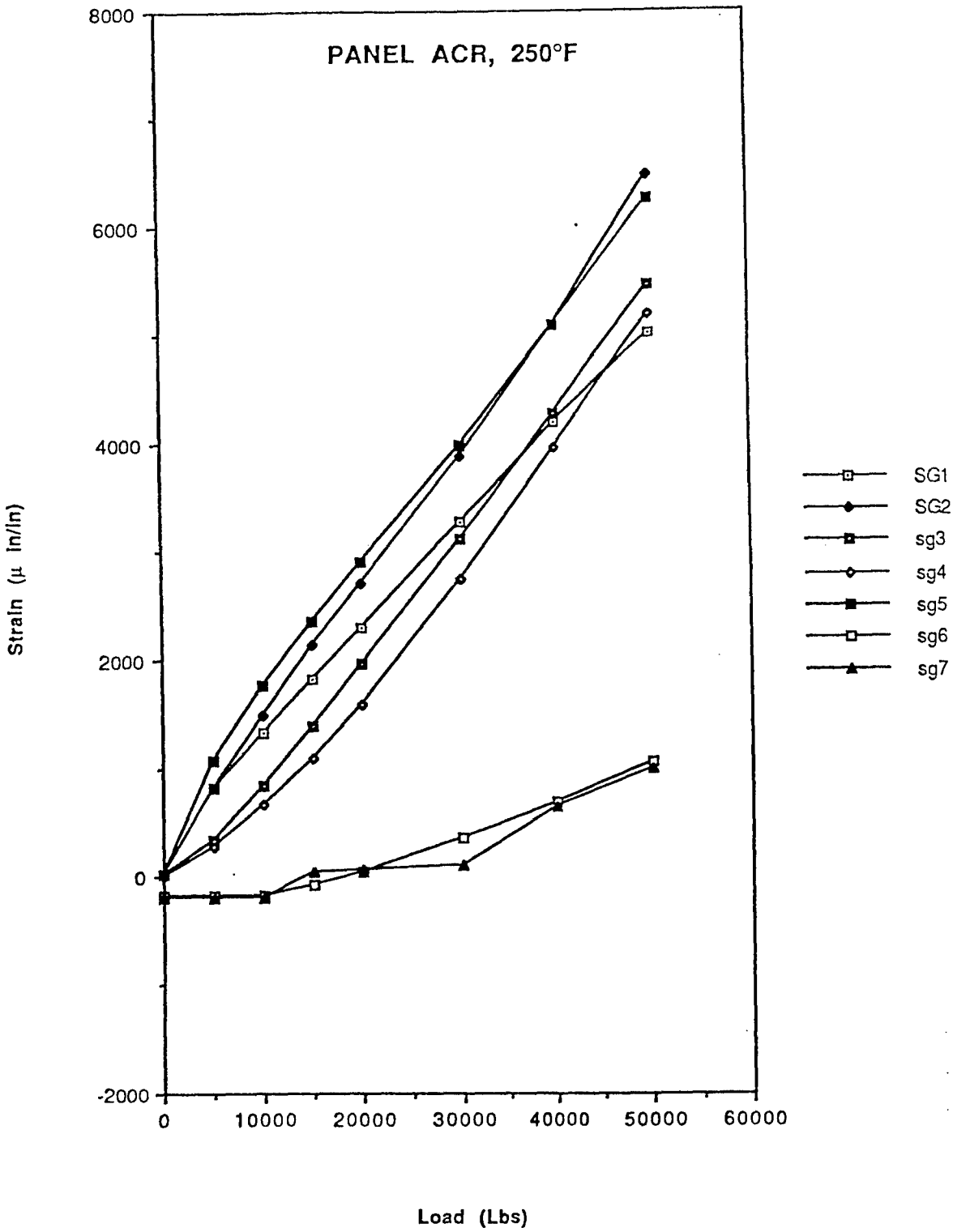

Figure 15

CONCLUSIONS

At room and elevated temperatures, no test problems were encountered as skin layup, patch type, and damage type were varied.

The clam-shell oven design developed by the Fatigue, Fracture and Reliability Group (WL/FIBEC) met the program requirements of size, space, and uniform temperature across the test area of the specimen. This design allowed for easier specimen insertion and instrumentation installation.

Evaluations of the fixture design showed no unequal strains across the panels, thereby allowing uniform loading of all patched and unpatched panels. When a bolted patch was applied to a specimen, some out-of-plane bending was induced as the loads were transferred from the skin to the patch which was mounted on the outer skin surface. In the case of a panel where the patch was small compared to the size of the panel, this bending was minimal and was usually ignored. Care will need to be taken when using the Composite Bolted Repair Analysis program to predict the behavior of patches on structures where bending is significant.

Verification of the predicted values were in line with the test results. This is shown in the Composite Bolted Repair Analysis report written by Forrest Sandow of Wright Laboratory Structural Survivability/Supportability Group (WL/FIBCA) (not yet published).