

NASA Contractor Report 189139

A247789



ADVANCED EXPANDER TEST BED PROGRAM

SECOND ANNUAL TECHNICAL PROGRESS REPORT

Pratt & Whitney
Government Engines & Space Propulsion
P.O. Box 109600
West Palm Beach, FL 33410-9600

March 1992

Prepared for:
Lewis Research Center
Under Contract No. NAB3-25960

National Aeronautics and
Space Administration

For sale by the National
Aeronautics and Space Administration
Distribution Unlimited

92-07280

Best Available Copy

FOREWORD

This report documents Advanced Expander Test Bed (AETB) activities conducted by Pratt & Whitney's (P&W) Government Engines & Space Propulsion Division during the period from 1 January 1991 through 31 December 1991. It is submitted in response to National Aeronautics and Space Administration-Lewis Research Center Contract NAS3-25960, Data Requirement 07.

The Project Manager for the program was Donald P. Riccardi and the Program Manager was James R. Brown.



Accession For	
NTIS GRA&I	<input checked="" type="checkbox"/>
DTIC TAB	<input type="checkbox"/>
Unannounced	<input type="checkbox"/>
Justification	
By	
Distribution/	
Availability Codes	
Dist	Special
A-1	

CONTENTS

Section		Page
I	INTRODUCTION	1
II	EXECUTIVE SUMMARY	3
III	TECHNICAL PROGRESS	5
	A. TASK 1.0 - PROGRAM MANAGEMENT	5
	B. TASK 2.0 - DESIGN AND ANALYSIS METHODOLOGY	5
	1. Steady-State Cycle Analysis	5
	2. Transient Cycle Analysis	10
	C. TASK 3.0 - PRELIMINARY DESIGN	11
	D. TASK 4.0 - FINAL DESIGN	11
	1. Oxygen Turbopump	11
	2. Hydrogen Turbopump	13
	3. Nozzle and Test Chamber Assembly	15
	4. Electronic Controller, Valves and Sensors	16
	5. Hydrogen Mixer	19
	6. System Integration	19
	E. TASK 8.0 - TECHNICAL ASSISTANCE	22
IV	CURRENT PROBLEMS AND FUTURE WORK	23

SECTION I INTRODUCTION

Mission studies at NASA have identified the need for a new Space Transfer Vehicle (STV) Propulsion System. The new system will be an oxygen/hydrogen expander cycle engine and must achieve high performance through efficient combustion, high combustion pressure, and high area ratio exhaust nozzle expansion. The engine should feature a high degree of versatility in terms of throttleability, operation over a wide range of mixture ratios, autogenous pressurization, in-flight engine cooldown, and propellant settling. Firm engine requirements include long life, man-rating, reusability, space-basing, and fault tolerant operation.

The Advanced Expander Test Bed (AETB), shown in Figure 1, is a key element in NASA's Space Chemical Engines Technology Program for development and demonstration of expander cycle oxygen/hydrogen engine and advanced component technologies applicable to space engines as well as launch vehicle upper stage engines. The AETB will be used to validate the high-pressure expander cycle concept, investigate system interactions, and conduct investigations of advanced mission focused components and new health monitoring techniques in an engine system environment. The split-expander cycle AETB will operate at combustion chamber pressures up to 1200 psia with propellant flow rates equivalent to 20,000 lbf vacuum thrust. The goals are summarized in Table 1.

Table 1. AETB Goals

Propellants	Oxygen/Hydrogen
Cycle	Expander
Thrust	Nominal 20,000 lbf
Pressure	Nominal 1200 psia
Mixture Ratio	6.0 ± 1.0 (Optional Operation at 12.0)
Throttling	100% to 5% Thrust
Propellant Inlet Conditions:	
Hydrogen	38 R, 70 psia
Oxygen	163 R, 70 psia
Idle Modes	Tankhead (Nonrotating Pumps) Pumped (Low-NPSH Pumping)
Life	100 Starts 5 Hours

The program is divided into eight tasks. Preliminary Design (Task 3.0) was completed on 31 January 1991 and has been followed by the final design (Task 4.0). Two AETB's will be fabricated, assembled, and acceptance tested at Pratt & Whitney (P&W). Both will then be delivered to NASA-Lewis Research Center (NASA-LeRC) where the bulk of the testing will be conducted. Development and verification of advanced design methods is another goal of the AETB Program. Under Task 2.0, steady-state and transient simulation codes will be produced. These two codes and selected design models will be verified during component and engine acceptance testing. The remaining tasks deal with Program Management (Task 1.0), Fabrication (Task 5.0), Component Tests (Task 6.0), Engine Acceptance (Task 7.0), and NASA Technical Assistance (Task 8.0).

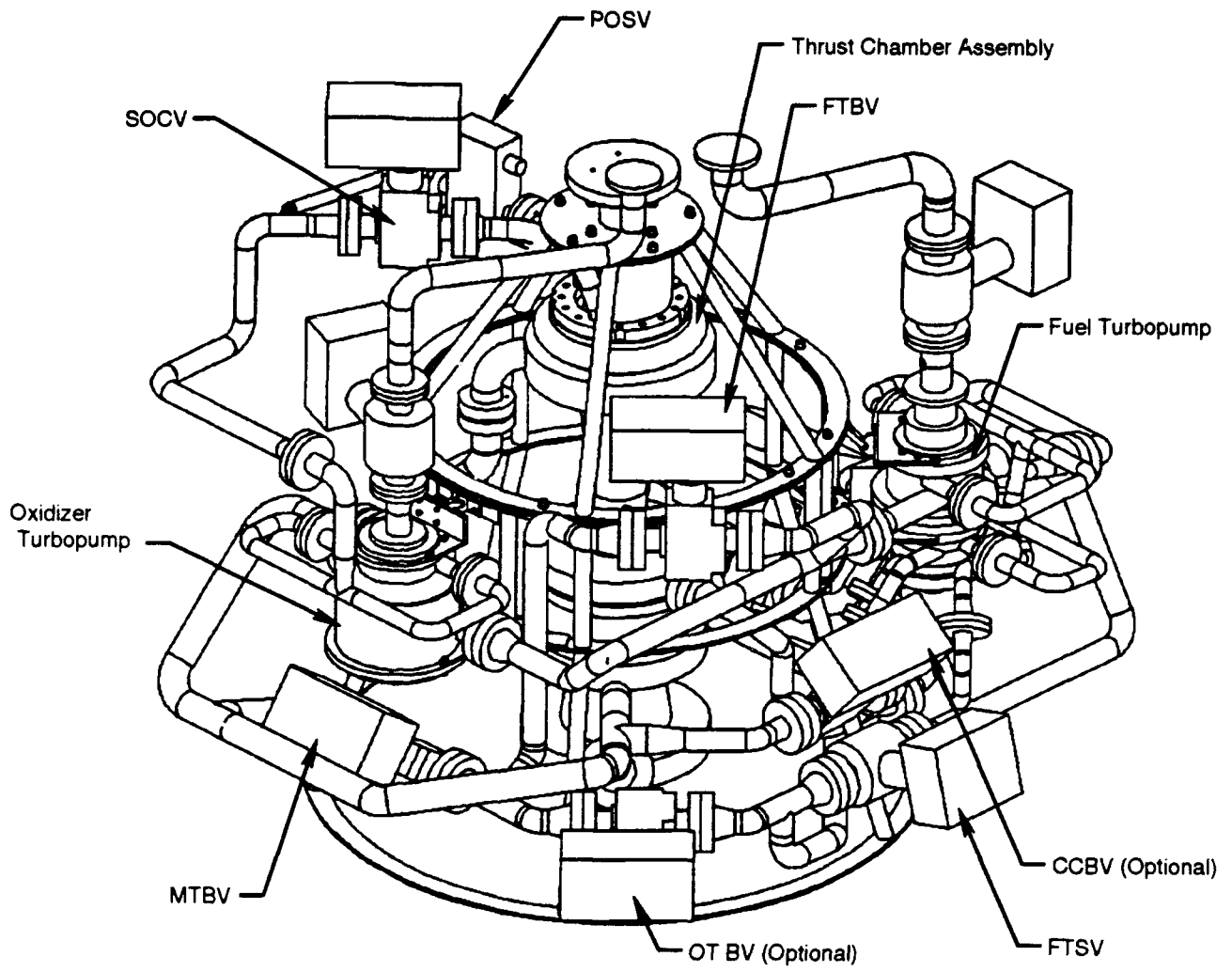

14953

Figure 1. AETB Assembly

SECTION II EXECUTIVE SUMMARY

The Preliminary Design Review (PDR) was held 29-31 January 1991 at NASA-LeRC. The preliminary design was approved and work on the final design was initiated in February 1991.

At NASA direction, the program was replanned to reflect a revised funding profile. The revised schedule, shown in Figure 2, will lead to completion of final Critical Design Review (CDR) in January 1993, with interim CDRs on the oxygen turbopump and the thrust chamber assembly in August 1992. The remainder of the final design task following CDR will consist of completion of detailed drawings. Test bed delivery is scheduled in March 1997.

Steady-state and transient simulation codes were continually updated to reflect design changes and improvements, particularly in regard to the hydrogen turbopump thrust balance arrangements and the results of injector element flow tests. An updated AETB steady-state simulation deck was delivered for installation on the NASA-LeRC computer.

The final design task is approximately 30 percent complete. The bulk of work in 1991 was focused on turbopump design, since final design of the thrust chamber, controller, and other components was deferred to a January 1992 start date. Full-time design activity on the oxygen turbopump recommenced in August 1991. Several changes were adopted to facilitate fabrication and assembly.

Changes in the hydrogen turbopump design were made primarily to balance thrust loads at all steady-state and transient conditions. Also in 1991, producibility of the first-stage impeller was taken up as a separate issue in an in-house program.

Design of an identical thrust chamber assembly, excluding the nozzle, was completed under an in-house program.

Welding trials validating the injector fabrication method were successfully accomplished, injector element flow tests were concluded, and copper forgings were procured for combustion chamber machining. Final design of the AETB nozzle was deferred to 1992 to stay within funding limits.

The controller design was improved with the incorporation of a new low-level interface board and a single 68040 processor. Procurement of certain valves needed to support early thrust chamber testing was begun with the selection of two suppliers and the kickoff of design work. The shaft speed sensors have been specified as fiber optic, rather than magnetic type, and a supplier was selected.

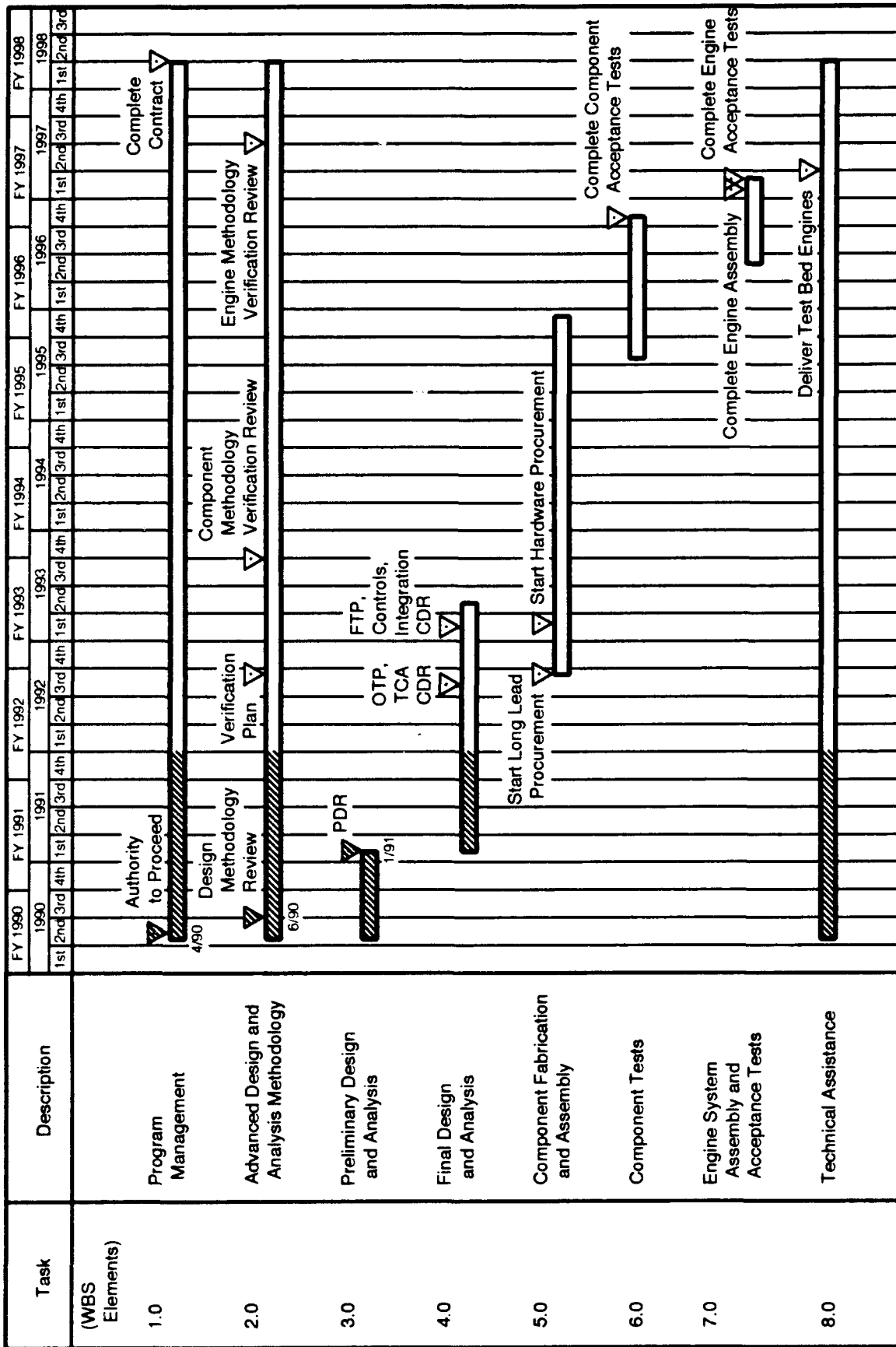

14954

Figure 2. Advanced Expander Test Bed Schedule

SECTION III TECHNICAL PROGRESS

A. TASK 1.0 - PROGRAM MANAGEMENT

The Program Management Task includes program control and administration; reports; travel; meetings; and system safety, reliability, and quality control.

1. Meetings
 - Technical Progress Reviews were held each month.
 - The Preliminary Design Review, held at the NASA-Lewis Research Center (NASA-LeRC) on 29-31 January 1991, summarized the work conducted by Pratt & Whitney Government Engines & Space Propulsion (P&W/GESP) division under Task 3.0 of the contract.
2. Reports — The following reports were submitted during 1991:
 - Quarterly Technical Progress Report: FR-21318-8, 30 April 1991
 - Quarterly Technical Progress Report: FR-21318-9, 31 July 1991
 - Quarterly Technical Progress Report: FR-21318-10, 31 October 1991
 - Final Annual Technical Progress Report: NASA CR 187082, April 1991
 - (Draft Annual Report submitted as FR-21319-1)
 - Preliminary Design Review Report: NASA CR 187081, May 1991
 - (Draft PDR Report submitted as FR-21329)
 - Preliminary Design Drawings: Submitted at PDR, January 1991.
3. Technical Papers — One technical paper entitled "Design of an Advanced Expander Test Bed", 91-3437, was presented at the AIAA/NASA/OAI Conference on Advanced SEI Technologies in Cleveland OH on 4 September 1991.
4. System Safety, Reliability and Quality Control — The Failure Modes and Effects Analysis (FMEA) and the Hazards Analysis were updated using the Control System Failure Analysis as input.

B. TASK 2.0 - DESIGN AND ANALYSIS METHODOLOGY

1. Steady-State Cycle Analysis

Following PDR an updated AETB steady-state simulation capable of generating the PDR design table was delivered to LeRC. Major improvements to this deck included a multinode heat exchanger to help predict off-design operating characteristics of the chamber and nozzle jacket, and the elimination of all volume routines within the deck to reduce run costs and improve convergence ability.

Engine baseline configuration changes were made due to concerns about pump cavitation margin at low power levels using fuel pump recirculation as a control mechanism. The FTBV was introduced into the baseline configuration to allow independent control of the LOX and fuel turbines and improve system flexibility at low power levels. Also, by using the FTBV in the baseline split expander configuration, no further modifications will be necessary for AETB high mixture ratio operation.

An in-depth thrust balance analysis of the primary and secondary fuel turbopumps was conducted over the entire throttling range, depicted in Figure 3. Preliminary analysis, based on steady-state data, predicted an unacceptable amount of shaft travel during throttling conditions. As a solution, certain cavities were vented and recirculated to reduce the force imbalance between the pump and turbine disks. With this scheme, engine

versatility was maintained since the venting effects can be minimized at any operating condition for which excess cycle power margin is low.

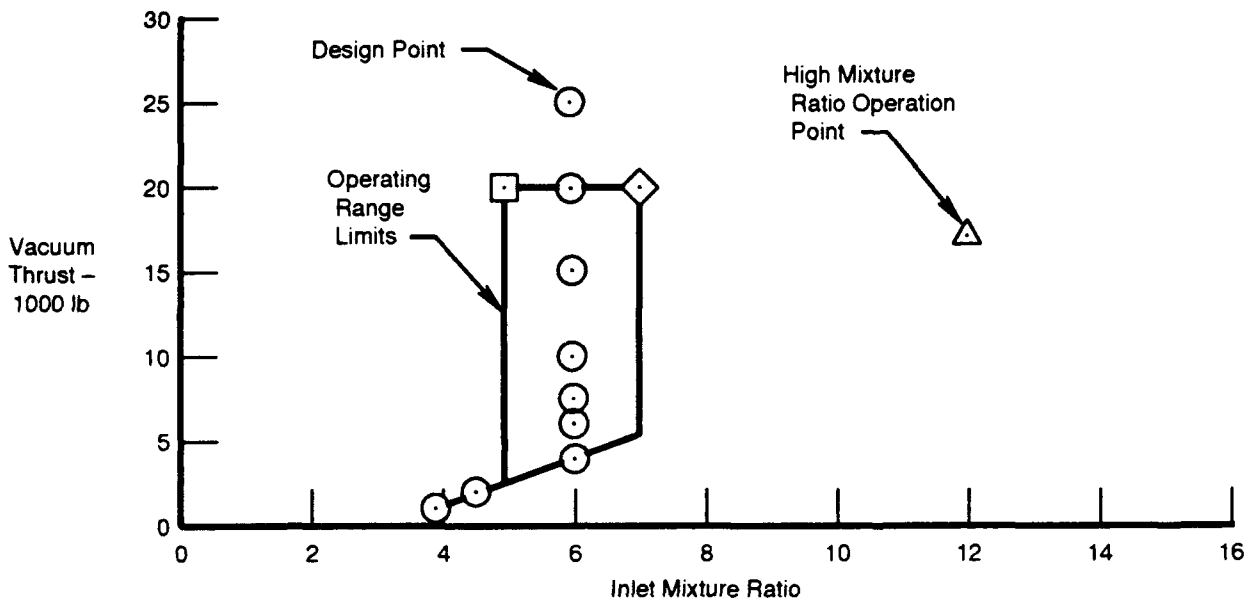

10320

Figure 3. AETB Operating Envelope

The final venting thrust balance scheme on the fuel turbopumps consists of external vents on both the primary and secondary pumps. Vented flow will be recirculated and introduced upstream of the pumps. The secondary pump vent will be required at all operating conditions, while the primary pump vent will be closed at power levels above approximately 85 percent rated power level in the split expander operating configuration. Both vents have the capability of being opened or closed as operating conditions dictate.

Based on the results of the thrust balance study, new design tables were generated and issued. The cycle calculations include the effects of internal component leakages and coolant flows. Table 2 lists key cycle parameters for the normal operating point, the updated design point, 5 percent and 20 percent throttled points, full-expander operation, and a high mixture operation point. A flow schematic for the engine model is shown in Figure 4 and internal flows are shown in Figure 5. After the new design table was issued, the steady-state deck available at LeRC was updated. The new deck has the ability to reproduce the new design table.

The design point shown in Table 2 was based on using a 15:1 LOX injector flow split between secondary and primary injectors. Flow tests conducted in July 1991 showed that the injectors would deliver the desired design point pressure drop (approximately 150 psid across each injector) at a 27:1 flow split. The 27:1 flow split could not be applied to the cycle, however, due to the adverse effects on engine and LOX pump throttling capability. This problem has been corrected with a recent injector design change that was flow tested in late December 1991. Preliminary analysis of the results show that this design can easily be incorporated into the engine system with minimal effect on engine performance or thrust balance. The new LOX injectors will operate with a flow split of 9.1:1 and a pressure drop across each injector of approximately 180 psid at the design point.

Table 2. AETB Cycle Summary

<i>Cycle Parameter</i>	<i>Uprated Design Point</i>	<i>Normal Operating Point</i>	<i>20% Thrust</i>	<i>5% Thrust</i>	<i>Full Expander Cycle</i>	<i>High Mixture Ratio</i>
Vacuum Thrust (E=1000:1) - lb	25204	20163	4026	1021	15981	17'26
Chamber Pressure - psia	1500	1198	238	65	946.9	1000
Mixture Ratio (Inlet)	6.00	6.00	6.00	3.91	6.00	12.0
1st Fuel Pump Speed - rpm	99869	87501	35515	16240	90000	81108
2nd Fuel Pump Speed - rpm	99273	87256	35061	16989	83563	71818
Fuel Pump Discharge Pressure - psia	4482.7	3511.5	691.6	217.1	3202.0	2748.8
Oxidizer Pump Speed - rpm	47607	41496	16108	7337	37480	42050
Oxidizer Pump Discharge Press. - psia	2182	1805	400.5	141.7	1608.1	1706.9
Oxidizer Turbine Inlet Temp - R	1012	968	1107	1239	681	1029.2
Fuel Turbine Inlet Temp - R	936	888	862	743	637	931.9
Chamber/Nozzle ΔP - psid	428	404	162	65	303	362
Chamber/Nozzle ΔT - R	906	876	1055	1197	905	941.2
Primary LOX Injector ΔP - psid	426	293	36.4	9.5	263	387
Secondary LOX Injector ΔP - psid	150	100	3.3	0.0	62	120
Turbine Bypass Flow - %	3.58	17.4	59.4	62.5	29.4	15.5
Jacket Bypass Flow - %	40.4	33.1	0.0	0.0	0.0	0.0
Primary Pump Venting	Closed	Closed	Open	Open	Closed	Closed

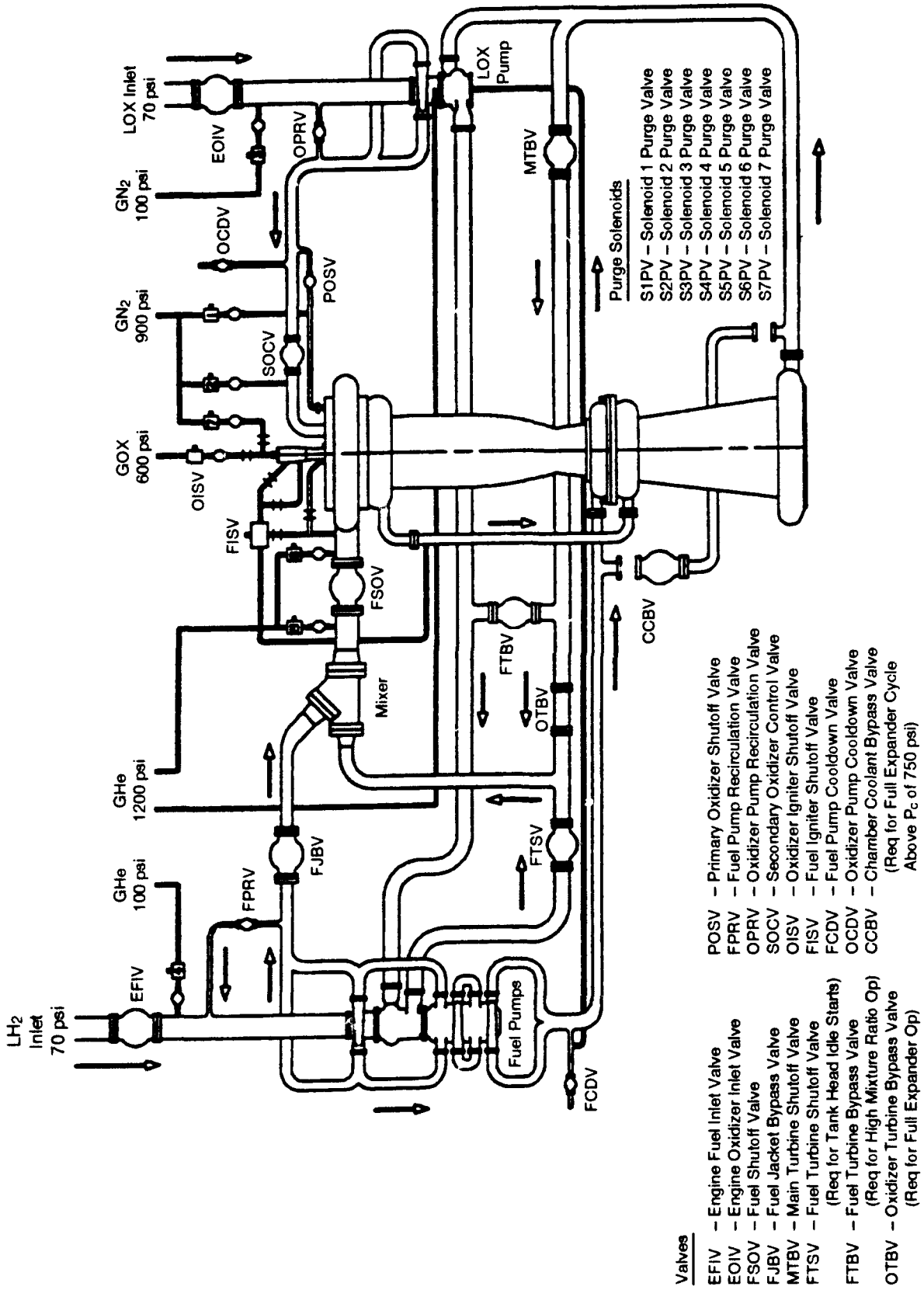
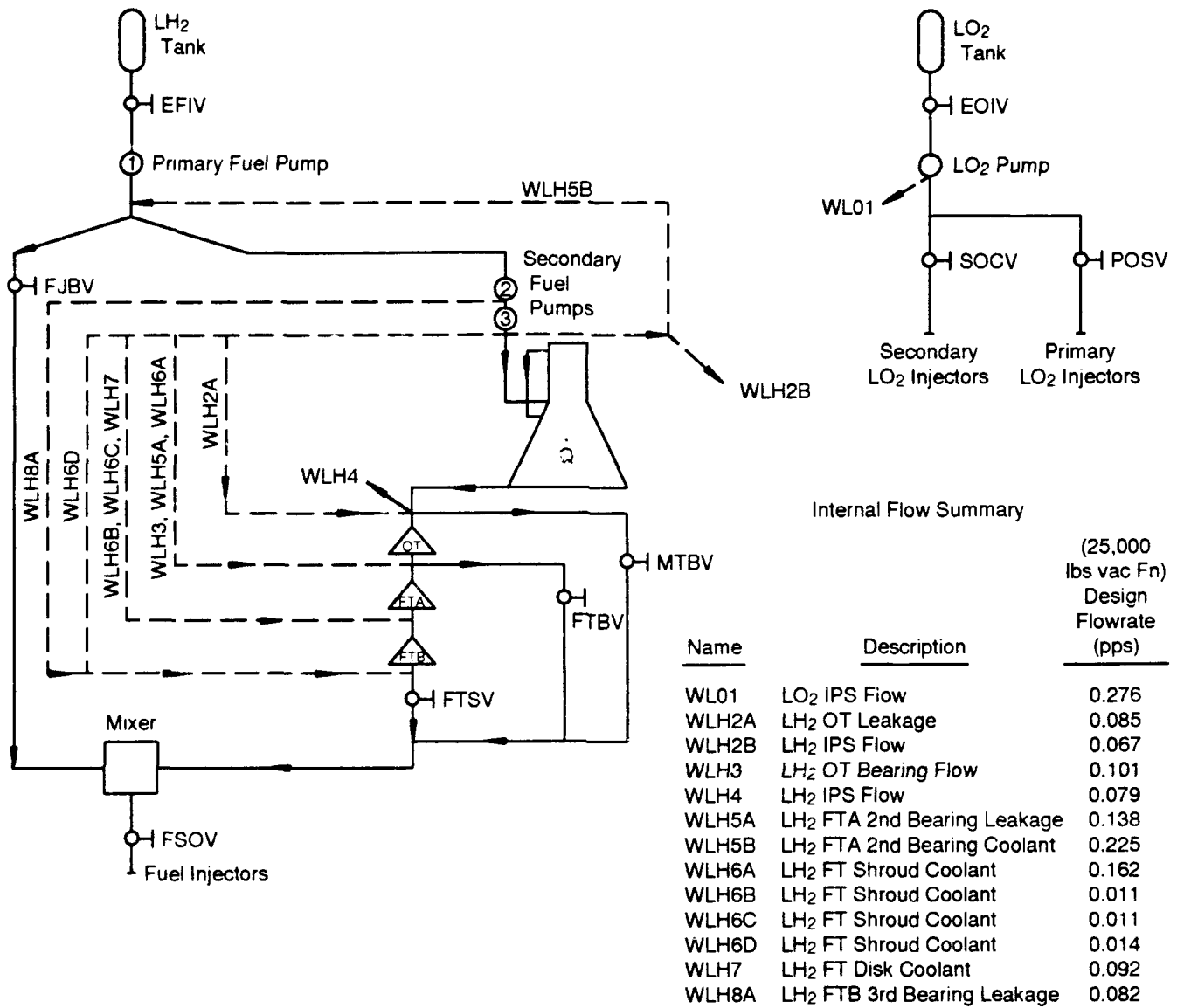

Figure 4. AETB Flow Schematic



10323

Figure 5. AETB Internal Flow Schematic

2. Transient Cycle Analysis

The AETB transient analysis occurred in three areas of work during 1991: (1) the continued enhancement of the AETB split expander transient model, (2) preliminary valve failure and valve slew rate sensitivity studies, and (3) definition of control logic requirements.

The process of enhancing the transient model involved several tasks. The heat exchanger routine was improved by defining six heat exchanger nodes for higher fidelity and the pump routines were modified to handle low NPSP performance regions. The transient model was converted into a double precision tool, which improved convergence performance and shortened run time. General ball valve characteristics were incorporated for all valves and the turbine and pump components were updated to the August 1991 version of the AETB split expander cycle design tables. Line inertias were included and all line geometries were updated. Secondary flows were incorporated, and gaseous oxygen was modelled as the purge gas for the LOX injectors. The transient model has been installed on the NASA-LeRC computer.

A preliminary failure analysis of the valve system shown above in Figure 4 was conducted to determine the effects of the failure of any single valve on the engine, both during start-up and at design thrust. The severity of valve failure was judged against the constraints of: (1) fuel pump speed less than 100,000 rpm, (2) oxygen pump speed less than 49,000 rpm, (3) turbine inlet temperature less than 1060 R, (4) no pump cavitation, and (5) no reverse flow through the fuel jacket bypass valve (FJBV).

The control system is designed to react to a valve failure when a valve is detected to be off its intended position for three consecutive data samples. Therefore, the time to achieve shutdown or corrective action following the failure of any one valve is the update rate times three, plus delays in the system due to solenoid actuation, solenoid buffering and brassboard sequencing, plus the shutdown slew rate of the valves. The determination is then made as to whether the failure results in a severe departure from the constraints imposed on the engine, as discussed above.

Five of the failures studied exhibited anomalous shutdown characteristics. However, only one failure resulted in a significant problem: The MTBV failing closed at 100 percent power causes an increase in speed of all pumps. Without corrective action, power level would rise to 130 percent, an unacceptable level. Furthermore, cavitation would occur in the primary fuel pump when undergoing shutdown procedures. The controller logic will be designed to resolve this problem.

A preliminary valve slew rate study was also conducted during 1991. The results indicate that the maximum acceptable slew rate tolerance is ± 10 percent. This requirement will be imposed upon the valve suppliers pending further analysis.

An update to the Control System Requirements Document (CSR) was published in February 1991. This update included changes to valve slew rate, accuracy, and position indication requirements. Sensor requirements of operating range, accuracy, and redundancy were also updated. All changes in this update reflected the AETB system as presented at PDR.

A study of the adequacy of the bandwidth of the main turbine bypass valve (MTBV) with regards to the thrust control loop was undertaken in February 1991. The response of the MTBV effector loop, with a 5 Hz bandwidth, was determined to be acceptable for thrust control of the AETB.

C. TASK 3.0 - PRELIMINARY DESIGN

Preliminary Design of the AETB was completed in 1990 and the Preliminary Design Review was held January 1991.

One subtask was kept active to continue Computational Fluid Dynamic (CFD) analysis of the hydrogen turbopump first-stage impeller. A grid of the AETB first-stage impeller was created from a CAD/CAM geometry definition file and using the 'EAGLE' code. Only one-sixth of the impeller was required to be modeled due to impeller symmetry. The model segment consisted of the blade and the two flow splitters.

Boundary conditions appropriate to the model were imposed onto the grid, however, the CFD flow solver was unable to reach a converged solution. The cause is believed to be the skewed and coarse nature of the impeller grid and the inability of EAGLE to generate this type of grid. An alternate, enhanced, in-house grid code, known as the 'Ni' deck, will be investigated as a means of generating the impeller grid.

D. TASK 4.0 - FINAL DESIGN

The final design effort began, with NASA approval, following the Preliminary Design Review (PDR) in February 1991. The pace of the design was not carried out as originally planned due to funding limitations in FY91. As of the end of 1991, design is proceeding with the objectives of completing the oxygen turbopump and the thrust chamber assembly final design in July 1992, the remaining components by the end of 1992, and holding the final Critical Design Review in January 1993.

1. Oxygen Turbopump

Design activity on the oxygen turbopump recommenced in August 1991. Several configuration changes were made to facilitate fabrication and assembly, reduce thermal stresses, and to address concerns about housing deflections. Major changes (Figure 6) were as follows:

- a. The inlet housing was redesigned to be separate from the pump discharge volute to allow easier removal for inspection.
- b. The turbine inlet and exit volutes were reconfigured as separate inserts to the main housings to reduce the influence of turbine volute temperatures on housing deflections.
- c. The bearing sleeves were redesigned to avoid applying axial thrust loads through the balls during assembly or disassembly. The length of the rotor had to be increased slightly to accommodate this change.

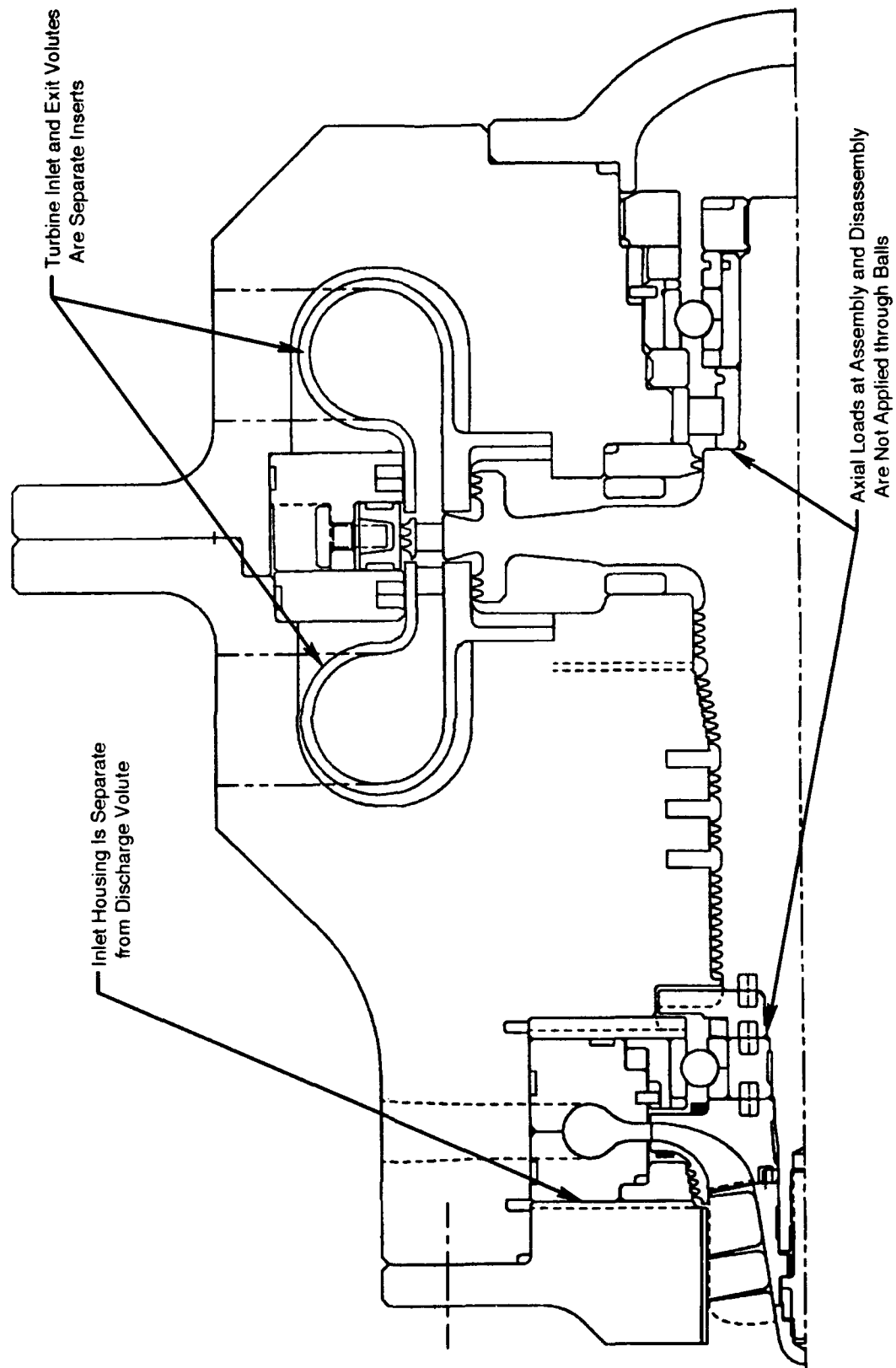

14956

Figure 6. Oxygen Turbopump Design Changes

2. Hydrogen Turbopump

The major efforts in hydrogen turbopump design were in the area of impeller fabrication and thrust balance (Figure 7).

- **Inducer/Impeller** — The major effort in this area was producibility of the first-stage impeller. The small size of the AETB shrouded impeller, together with the splitter blade rows included for throttling reasons, results in a configuration that is difficult to machine. An in-house program was initiated to investigate alternate manufacturing methods. The principal approach was to divide the impeller into two or more pieces for machining of the passages, then diffusion bonding the pieces together. A trial bonding was made using three concentric rings that incorporated simulated impeller passages. Although the rings were not 100 percent bonded, the trial was judged to be satisfactory as a proof of the bonding concept. Future bonding trials will be made with titanium segments which more closely resemble an actual impeller.
- **Turbine/Shafts** — Options for controlling and absorbing rotor thrust loads were studied in detail. The configuration adopted was a combination of venting certain cavities to reduce steady-state thrust loads and incorporating bumpers on the center line of both pump segments to absorb transient loads and provide design margin. A preliminary determination indicated that wear on the rear bumper of the primary pump segment (the worst case) would be no more than 0.003 inch over 100 missions.

Airfoil geometry for the primary and secondary turbine blades and vanes was completed and incorporated into the mechanical design.

- **Housings** — Changes in housing design since completion of preliminary design include:
 1. Incorporation of dual pump inlet volutes to improve flow into the second and third stages, i.e., secondary pump, in place of constant cross-sectional area inlets
 2. Housing geometry was designed to provide passages for the rotor thrust balance system, which will be vented through external lines so that thrust balance parameters can be adjusted without disassembling the pump
 3. Turbine inlet and exit housings were redesigned to improve turbine performance and ease assembly.
 4. Provisions were investigated for NASA to install health monitoring instrumentation post-delivery.
- **Structural Analysis** — Two-dimensional body-of-revolution NASTRAN models of the primary and secondary rotors were completed in 1991. Using these models, safety margins and low cycle fatigue (LCF) life of the rotors were analyzed for assembly load conditions. Two- and three-dimensional NASTRAN analyses of the first-stage impeller were completed and indicated that adequate margins of safety and LCF life were met for the 20,000 lbf thrust operating condition.

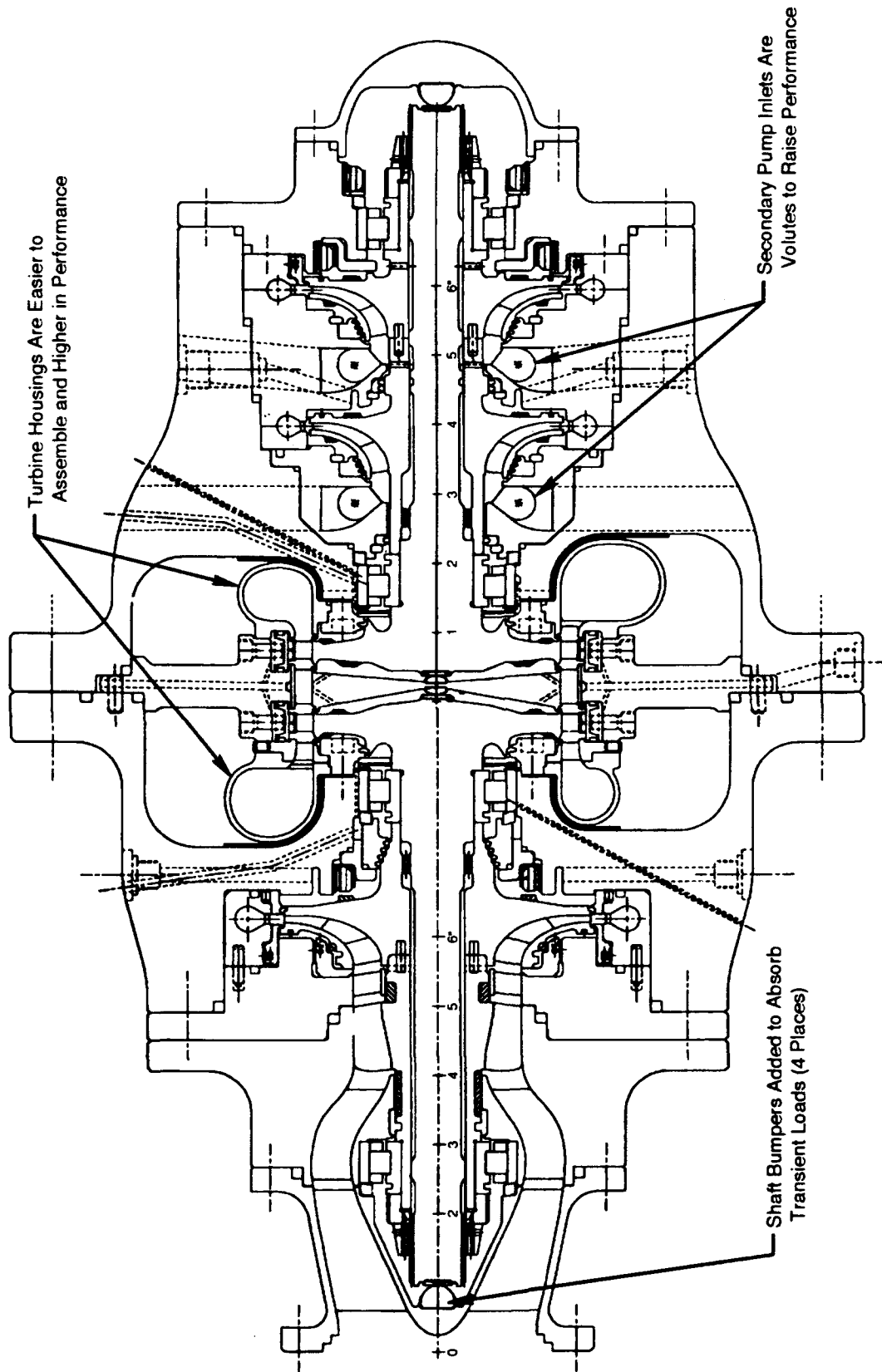

14957

Figure 7. Hydrogen Turbopump Design Changes

3. Nozzle and Thrust Chamber Assembly

The thrust chamber assembly consists of an injector with igniter, combustion chamber, and a conical nozzle extension, as shown in Figure 8. The dual-orifice injector and milled-channel liner combustion chamber are based on an existing design completed and detailed under a P&W Space Engine Component Technology (IR&D) Program. Although contract work on the assembly in 1991 included only the completion of the preliminary layout of the exhaust nozzle, the current state of all the hot section components is described below.

- **Injector/Igniter** — No changes to the AETB igniter have been incorporated since the release of the PDR Report and none are anticipated. Detail drawings have been released and fabrication of parts for the assembly of the IR&D rig igniter is in progress.

The injector assembly has changed little since the PDR report. The material of the LOX ring and LOX dome was changed from AISI 347 SST to INCONEL 625 to improve weldability by the electron beam method. A full-size pressure test sample of the injector housing, LOX ring, and LOX dome was produced for cryogenic shocking and cyclic pressure testing. No anomalies or indications were noted in the weld joints; detailed microscopic examinations will be performed to confirm the initial results.

Injector element characterization has been completed under the P&W in-house program. The testing under Phase I of the program provided characteristic data on the injector element as initially designed. As a result, the LOX element and sleeve were modified to match the cycle requirements more closely. The element flow area was enlarged to provide a larger total flow coefficient. The flow split between the primary and secondary circuits was also adjusted to provide a better mixture ratio distribution across the injector when operating at lower power points. Testing under Phase II of the program validated these design changes.

- **Combustion Chamber** — The combustion chamber design, including detail drawings, was completed and fabrication of the milled liner for the IR&D rig is in progress. The first set of three NASA-Z forgings was received and inspection and another set of two forgings are scheduled for delivery the first half of 1992.
- **Exhaust Nozzle** — Final design of the conical nozzle extension will start January 1992. No major changes from the preliminary design are anticipated.

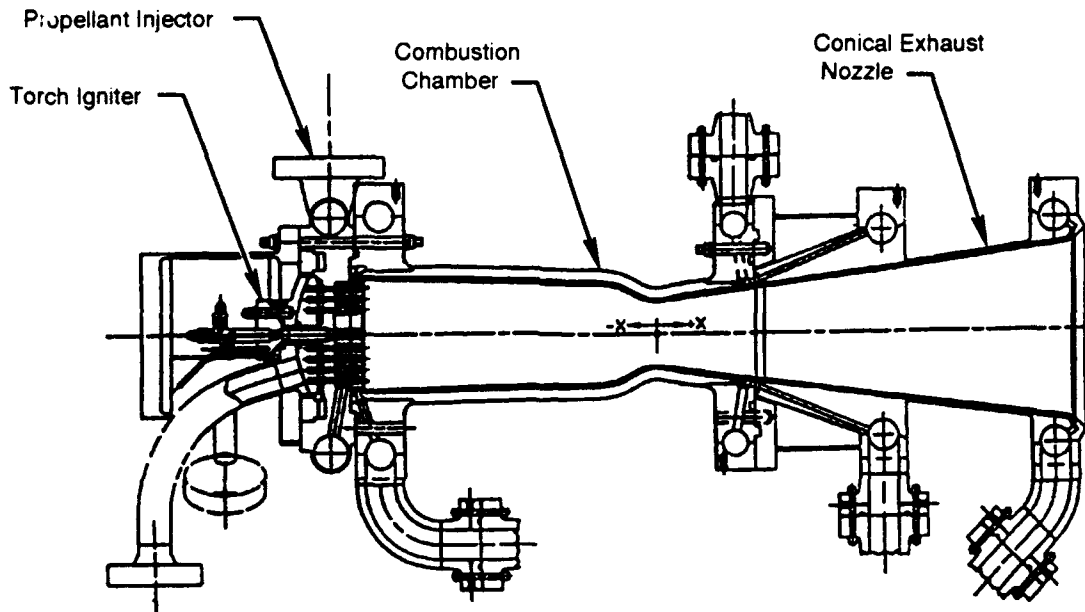

14958

Figure 8. AETB Thrust Chamber Assembly

4. Electronic Controller, Valves and Sensors

The control system consists of the electronic controller, valves, actuators, ignition system, and feedback sensors. Due to the program funding limitation and schedule stretch, the bulk of the control system detail design was delayed until 1992. However, some significant design accomplishments occurred in 1991 and are summarized below.

- Electronic Controller — Hamilton Standard (HSD) completed detailed design of a new low level interface board (Figure 9) having the capability of interfacing with nineteen low-level thermocouple sensors, twenty-one strain gage pressure sensors and seven resistive temperature devices (RTD). This custom single board approach replaced five boards required by the initial conceptual system design. System benefits include the following:
 1. Increased number of spare board slots
 2. Enhanced reliability (fewer parts)
 3. Added growth capability
 4. Adaptability adaptable to changing sensor requirements (hardware/software).

An analysis of this low level board design showed that all interface accuracy requirements were met. Table 3 shows the accuracy requirements and the calculated accuracy values.

A layout of the board (Figure 10) indicates that, although a multi-layer board is required, the board will fit in the space reserved for one slot in the card cage.

A corresponding interface design was completed for the brassboard test system. These revisions provide an accurate simulation of the sensor types and quantities with which the low level board will interface.

Input/Output (I/O) software development was also initiated. Software design requirements are being documented in a Hardware/Software Interface Requirements Specification. The initial version of this document is complete and contains I/O interface board requirements.

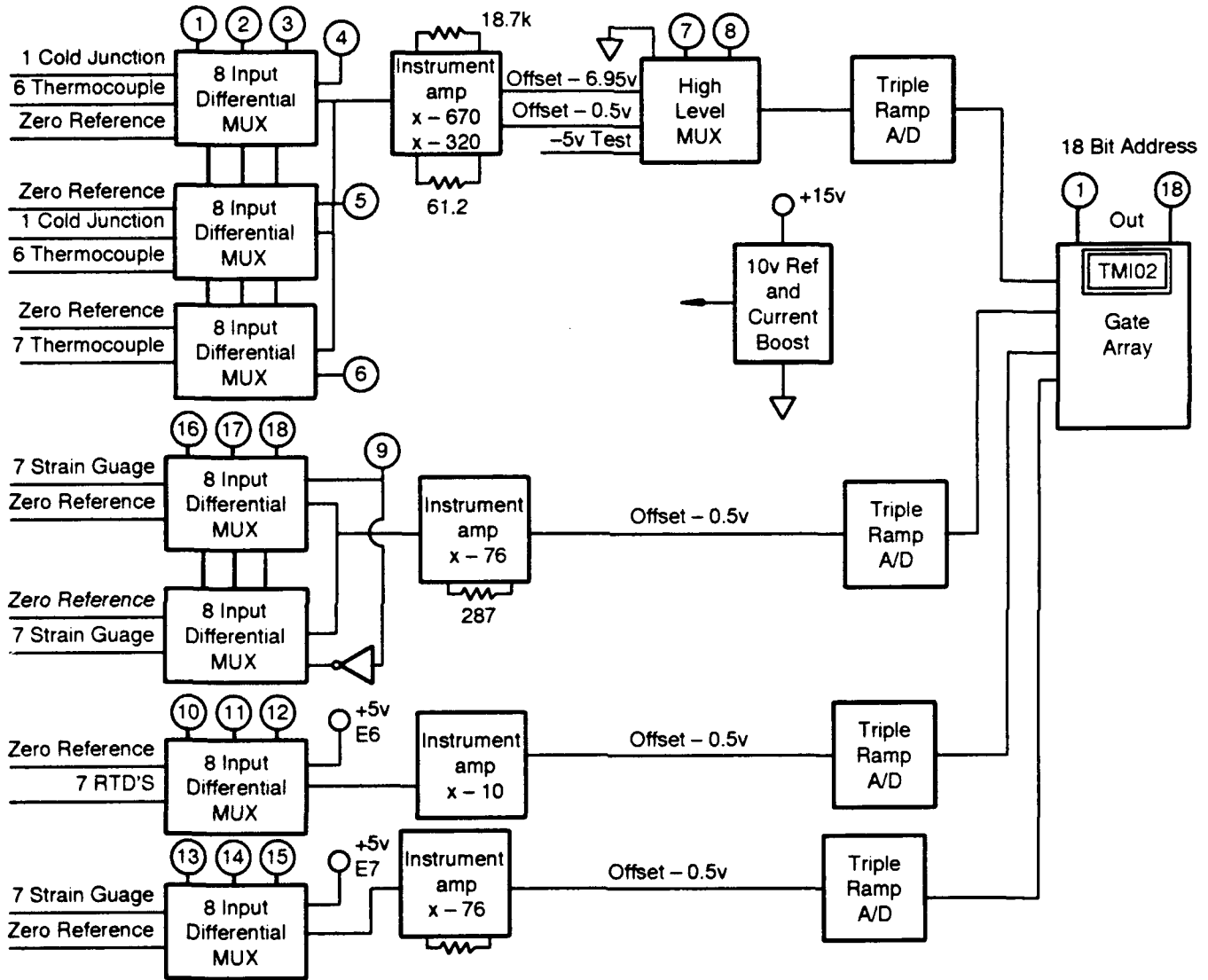

14959

Figure 9. Low Level Interface Board Design

Table 3. Low Level Board Interface Accuracies

Low Level Board Interface	Accuracy Requirement	Calculated Accuracy
Thermocouple		
- Absolute	9.1°F	6.04°F
- Relative	2.0°F	1.9°F
Strain Gage Pressure	±0.5% Full Scale	±0.3% Full Scale
Resistive Temp Device (RTD)	10.0°F	1.5°F

The remaining hardware interface requirements will be incorporated prior to Critical Design Review. A baseline I/O software design has been created from an existing National Aero-Space Plane (NASP) design. Modifications are now being performed to reflect the unique AETB system requirements. To date, the I/O logic designs for the frequency, LVDT, and analog boards have been modified.

The program replan includes incorporation of a technology upgrade to the brassboard design. A single 68040 processor replaced the pair of 1750 processors. This upgrade provides 100 percent VME compatibility and simplifies the software design and processor interface, while providing additional growth for throughput and memory, and increased availability of support tools.

Coordination with Hamilton Standard resulted in updates to the hardware performance specifications for the brassboard controller, monitor system, and brassboard test system. These updates reflect the new processor design and revised I/O requirements to meet the evolving test bed system design.

During preliminary design, a frequency board was selected for speed signal conversions. To establish the board capability to meet speed signal conversion and accuracy requirements over the defined operating range, investigative testing of the board was performed and the capability to input the three defined-speed signals and one spare signal throughout their operating ranges was verified. Accuracy requirements at these speed ranges was also verified.

An Interface Control Document (ICD) was defined for the interfaces between the controller and

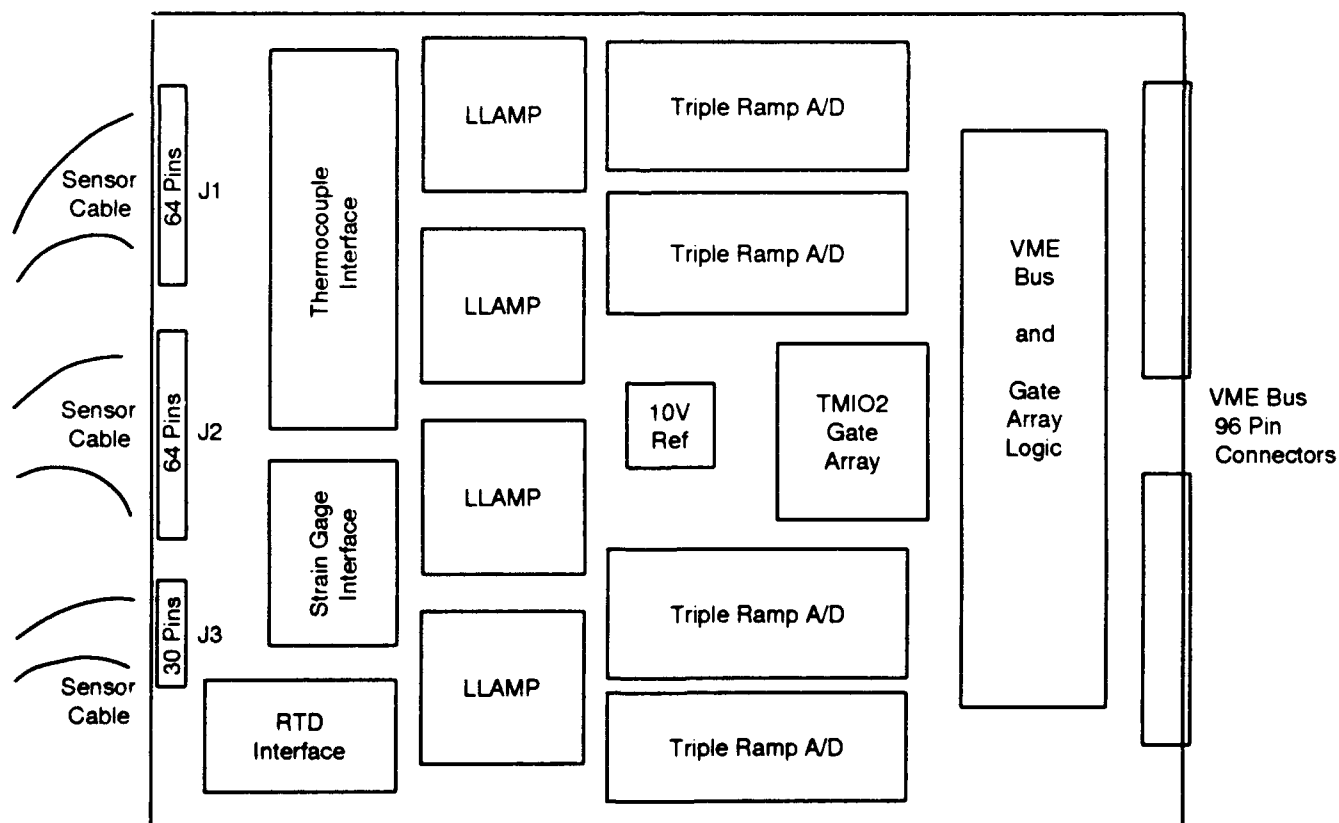

14960

Figure 10. Low Level Board Layout

external hardware. These include sensors, effectors and facility interfaces. The Preliminary Monitor User's Manual was also completed.

The initial Control Laws System Requirement Specification (SRS), the Input/Output SRS and the Software Development Plan (SDP) were completed. These documents are being revised for the new processor design. The SRS defines system level requirements for each processor from which the software design can be performed. The SDP defines the software design, programming and verification processes.

- Valves and Actuators — The technical evaluations of control and shutoff valve supplier proposals were finalized and final supplier selection completed. Under the new program schedule, the FJBV, SOCV, and POSV will be delivered in November 1992 for early checkout in conjunction with other planned testing. To support this delivery, valve supplier critical design reviews for these three valves have been scheduled for April 1992. All other valve deliveries have been scheduled for June 1995 with the associated installation and layout drawing reviews occurring just prior to test bed CDR. The control and shutoff valve suppliers were selected as follows.
 1. Control Valves:
 - a. SOCV, MTBV, FTBV - Allied Signal Aerospace, Garrett Fluid Systems Division
 - b. FJBV, FPRV - Flodyne Controls
 2. Shutoff Valves:
 - a. EOFIV, EFIV - RL10 Bill-of-Material
 - b. FTSV, FSOV, FISV - Allied Signal Aerospace, Garrett Fluid Systems Division
 - c. FCDV, OCDV, PSOV, OPRV, OISV - Flodyne Controls

The program kickoff meeting was held with Garrett Fluid Systems Division in December 1991. The kickoff meeting with Flodyne Controls will occur early in 1992.

- Sensors — The shaft speed sensor type presented at PDR has been changed from magnetic pickup to fiber optic. The statement-of-work for the design of the fiber optic speed sensors was completed. Competitive bids were received to perform the preliminary design of the fiber optic speed sensors. A supplier was selected and placement of the purchase order completed. The first technical review will take place in the first Quarter of 1992. The design effort on all other sensors was delayed until mid-1992.

5. Hydrogen Mixer

The layout of the hydrogen mixer has been completed. The design is unchanged from that reported in the Annual Technical Progress Report (CR 187082), dated April 1991.

6. System Integration

Under the system integration task, all propellant lines and component supports are being designed, and engine components are being mechanically integrated into the test bed configuration. Significant accomplishments for 1991 are summarized below.

- In response to questions raised at PDR, the frame design has been modified so that the thrust loads can be supported at either the top or the bottom of the frame. The base of the frame was widened to facilitate mounting in NASA-LeRC's RETF test facility and to accept future space nozzle designs.

- The frame was changed to a two-piece assembly with thrust chamber assembly removal through either the top or bottom. The side removal option for the thrust chamber assembly was eliminated as being unnecessary when using NASA test facilities. The new frame also has fewer frame members, thus providing increased accessibility to the thrust chamber it encloses. The new frame is shown in the engine buildup sequence, Figure 11.
- A rough estimate of the test bed assembly weight was determined to be approximately 2200 pounds.
- Some of the flanges have been changed to a design commonly used in test facilities. The flange selected is called E-CON, from Reflange, Inc. The E-CON flange features seal surfaces on the ID as opposed to the less rugged standard face seal, and provides a higher temperature capability.

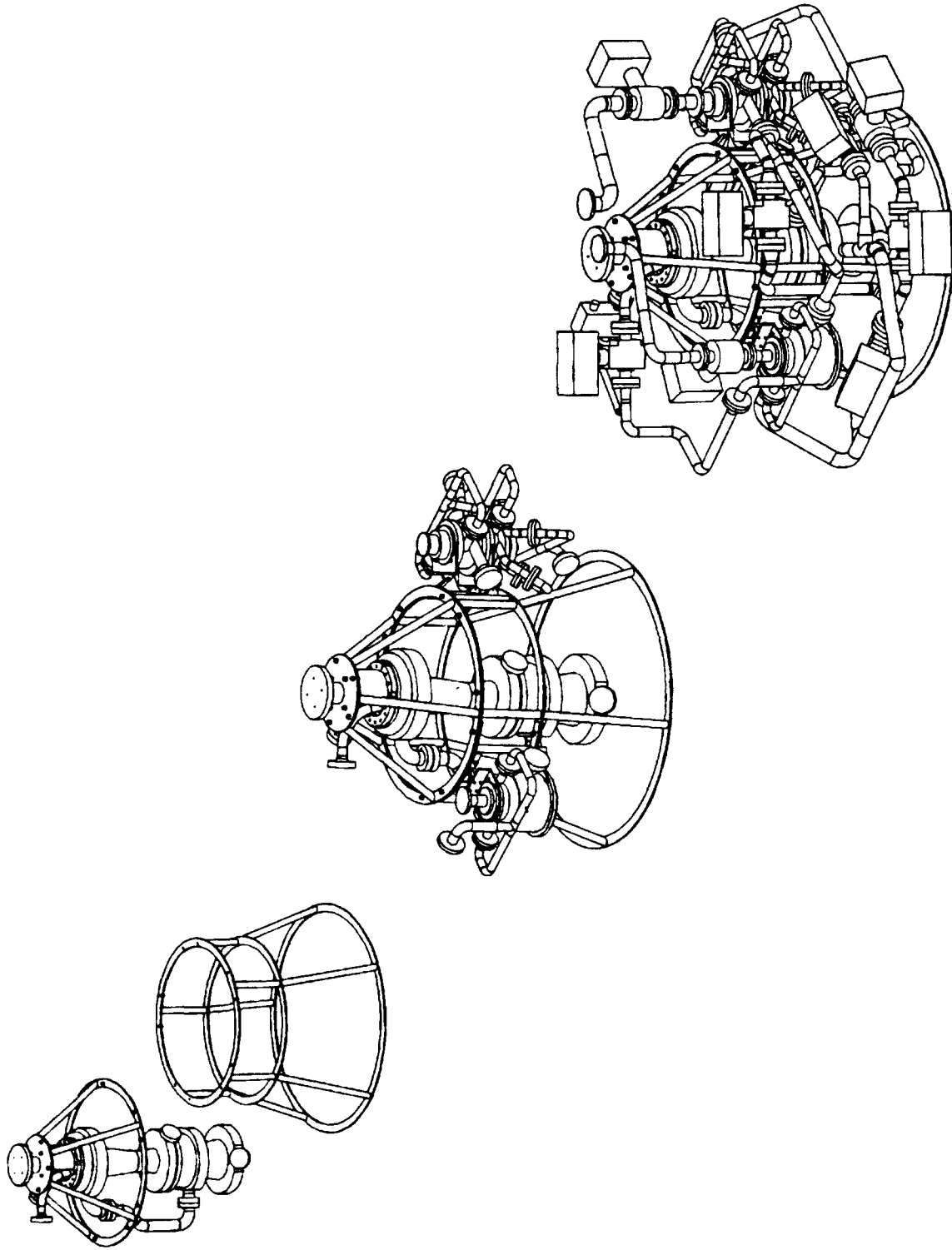

14961

Figure 11. Engine Buildup Sequence

E. TASK 8.0 - TECHNICAL ASSISTANCE

Task Order No. 2 was received in December 1991 and will be initiated in January 1992. Under this order, RL10 engine physical and performance data will be provided to NASA-LeRC for verifying the ROCETS computer model and evaluating various RL10 modifications.

SECTION IV CURRENT PROBLEMS AND FUTURE WORK

No technical problems have been encountered that would prevent the successful completion or affect the program schedule shown in Section II.

Work planned in 1992 includes:

- Presentation of the CDR in August 1992 for both the oxygen turbopump and the thrust chamber assembly
- Completion of final design of the hydrogen turbopump, valves, controls, mixer, and other components including external lines
- Changes to the transient simulation model to incorporate:
 1. Valve actuator characteristics
 2. Closed loop thrust control
 3. Thrust balance routine to calculate impeller axial position
 4. Control logic.
- Providing technical assistance to NASA Lewis Research Center, under Task Order 2 dated 16 December 1991, in supplying RL10 modeling data for the ROCETS computer program.



Report Documentation Page

1. Report No. CR-189130	2. Government Accession No.	3. Recipient's Catalog No.	
4. Title and Subtitle ADVANCED EXPANDER TEST BED ENGINE Second Annual Technical Progress Report		5. Report Date March 1992	
		6. Performing Organization Code	
7. Author(s) D.P. Riccardi, J.P. Mitchell, et. al.		8. Performing Organization Report No. FR-21319-2	
		10. Work Unit No. 593-12-41	
9. Performing Organization Name and Address Pratt & Whitney P.O. Box 109600 West Palm Beach, FL 33410-9600		11. Contract or Grant No. NAS3-25960	
		13. Type of Report and Period Covered Annual Report 1 Jan - 31 Dec 1991	
12. Sponsoring Agency Name and Address NASA Lewis Research Center 21000 Brookpark Road Cleveland, OH 44135		14. Sponsoring Agency Code	
15. Supplementary Notes Program Manager: W.K. Tabata			
16. Abstract <p>The Advanced Expander Test Bed (AETB) is a key element in NASA's Space Chemical Engine Technology Program for development and demonstration of expander cycle oxygen/hydrogen engine and advanced component technologies applicable to space engines as well as launch vehicle upper stage engines. The AETB will be used to validate the high-pressure expander cycle concept, investigate system interactions, and conduct investigations of advanced mission focused components and new health monitoring techniques in an engine system environment. The split expander cycle AETB will operate at combustion chamber pressures up to 1200 psia with propellant flow rates equivalent to 20,000 lbf vacuum thrust.</p> <p>Contract work began 27 April 1990. During 1991, work was concentrated mainly on: (1) the Preliminary Design Review and subsequent publishing of the PDR Report, (2) updating the steady-state and transient simulation models to reflect design changes, and (3) analytical and mechanical design of engine components, primarily the turbopumps.</p>			
17. Key Words (Suggested by Author(s)) Space Propulsion Rocket Design Expander Cycle Engines Oxygen/Hydrogen Engines Liquid Propellant Rockets		18. Distribution Statement General Release	
19. Security Classif. (of this report) Unclassified	20. Security Classif. (of this page) Unclassified	21. No. of Pages 26	22. Price*