

2

AD-A247 442



IDA PAPER P-2570

AVAILABILITY OF COMMUNICATIONS
FOR THE NATO AIR COMMAND AND
CONTROL SYSTEM IN THE CENTRAL REGION
AND 5ATAF

R. A. Enlow, *Project Leader*

October 1991

DTIC
SELECTE
MAR 3 1992
S B D

Prepared for
Office of the Assistant Secretary of Defense (C3I)

Public release/unlimited distribution. Review of this material does not imply Department of Defense endorsement of factual accuracy or opinion.

92-05210



INSTITUTE FOR DEFENSE ANALYSES
1801 N. Beauregard Street, Alexandria, Virginia 22311-1772

DEFINITIONS

IDA publishes the following documents to report the results of its work.

Reports

Reports are the most authoritative and most carefully considered products IDA publishes. They normally embody results of major projects which (a) have a direct bearing on decisions affecting major programs, (b) address issues of significant concern to the Executive Branch, the Congress and/or the public, or (c) address issues that have significant economic implications. IDA Reports are reviewed by outside panels of experts to ensure their high quality and relevance to the problems studied, and they are released by the President of IDA.

Group Reports

Group Reports record the findings and results of IDA established working groups and panels composed of senior individuals addressing major issues which otherwise would be the subject of an IDA Report. IDA Group Reports are reviewed by the senior individuals responsible for the project and others as selected by IDA to ensure their high quality and relevance to the problems studied, and are released by the President of IDA.

Papers

Papers, also authoritative and carefully considered products of IDA, address studies that are narrower in scope than those covered in Reports. IDA Papers are reviewed to ensure that they meet the high standards expected of refereed papers in professional journals or formal Agency reports.

Documents

IDA Documents are used for the convenience of the sponsors or the analysts (a) to record substantive work done in quick reaction studies, (b) to record the proceedings of conferences and meetings, (c) to make available preliminary and tentative results of analyses, (d) to record data developed in the course of an investigation, or (e) to forward information that is essentially unanalyzed and unevaluated. The review of IDA Documents is suited to their content and intended use.

The work reported in this document was conducted under contract MDA 903 89 C 0003 for the Department of Defense. The publication of this IDA document does not indicate endorsement by the Department of Defense, nor should the contents be construed as reflecting the official position of that Agency.

UNCLASSIFIED

IDA PAPER P-2570

**AVAILABILITY OF COMMUNICATIONS
FOR THE NATO AIR COMMAND AND
CONTROL SYSTEM IN THE CENTRAL REGION
AND 5ATAF**

R. A. Enlow, *Project Leader*
D. N. Kyle
C. L. Gordon

October 1991

Public release/unlimited distribution. Review of this material does not imply Department of Defense endorsement of factual accuracy or opinion.



INSTITUTE FOR DEFENSE ANALYSES

Contract MDA 903 89 C 0003

Task T-J1-684

UNCLASSIFIED

REPORT DOCUMENTATION PAGE

Form Approved
OMB No. 0704-0188

Public reporting burden for this collection of information is estimated to average 1 hour per response, including the time for reviewing instructions, searching existing data sources, gathering and maintaining the data needed, and completing and reviewing the collection of information. Send comments regarding this burden estimate or any other aspect of this collection of information, including suggestions for reducing this burden, to Washington Headquarters Service, Directorate for Information Operations and Reports, 1215 Jefferson Davis Highway, Suite 1204, Arlington, VA 22202-4302, and to the Office of Management and Budget, Paperwork Reduction Project (0704-0188), Washington, DC 20503.

1. AGENCY USE ONLY (Leave blank)	2. REPORT DATE October 1991	3. REPORT TYPE AND DATES COVERED Final	
4. TITLE AND SUBTITLE Availability of Communications for the NATO Air Command and Control System in the Central Region and 5 ATAF		5. FUNDING NUMBERS MDA 903 89 C 0003 Task T-J1-684	
6. AUTHOR(S) R.A. Enlow, D.N. Kyle, C.L. Gordon			
7. PERFORMING ORGANIZATION NAME(S) AND ADDRESS(ES) Institute for Defense Analyses 1801 N. Beauregard St. Alexandria, VA 22311		8. PERFORMING ORGANIZATION REPORT NUMBER P-2570	
9. SPONSORING/MONITORING AGENCY NAME(S) AND ADDRESS(ES) OASD (C3I) Room 3D174, The Pentagon Washington, DC 20301		10. SPONSORING/MONITORING AGENCY REPORT NUMBER Director, FFRDC Programs 1801 N. Beauregard St. Alexandria, VA 22311	
11. SUPPLEMENTARY NOTES			
12a. DISTRIBUTION/AVAILABILITY STATEMENT Public release/unlimited distribution. Review of this material does not imply Department of Defense endorsement of factual accuracy or opinion.		12b. DISTRIBUTION CODE	
13. ABSTRACT (Maximum 200 words) The purpose of this study is to assess the availability of the communications required to support the planned NATO Air Command and Control System. The existing and planned ground-to-ground communications infrastructure of the Central Region (Germany, Netherlands, Belgium) and Italy are surveyed. Both national military and NATO systems are included. The requirements of the NATO Air Command and Control System for ground-to-ground communications are compared to the infrastructures identified in the survey. Shortfalls are identified in the areas of schedule, technical standards, switching standards, and interoperability. A risk assessment concludes the paper.			
14. SUBJECT TERMS : NATO, Air Command and Control Systems, ACCS, GAFACS, BEMILCON, NATO Terrestrial Telecommunications System, NTTs, FAF ISDN, DITSN, ASCON, NAFIN, DCS		15. NUMBER OF PAGES 167	16. PRICE CODE
17. SECURITY CLASSIFICATION OF REPORT UNCLASSIFIED	18. SECURITY CLASSIFICATION OF THIS PAGE UNCLASSIFIED	19. SECURITY CLASSIFICATION OF ABSTRACT UNCLASSIFIED	20. LIMITATION OF ABSTRACT SAME AS REPORT

UNCLASSIFIED

PREFACE

This project has been conducted by the System Evaluation Division of the Institute for Defense Analyses (IDA) in response to a request by the Assistant Secretary of Defense for Command, Control, Communications and Intelligence [ASD(C3I)].¹

The purpose of this paper is to compare the communications infrastructure required to implement the NATO Air Command Armed Control System with the existing and planned NATO/National Communications. The NATO Central Region and the 5th Allied Tactical Air Force region (Italy) were used for detailed geographical comparisons.

The IDA project team consisted of Dr. Ronald A. Enlow (Project Leader), COL C. Larry Gordon (USA, Ret.), and Mr. Dudley Kyle. The review comments of the IDA Technical Review Committee are gratefully acknowledged. The committee was chaired by Dr. David L. Randall, Director, System Evaluation Division, and members were Dr. John R. Shea, Dr. Peter S. Liou, Mr. Harold A. Cheilek and Dr. Herbert M. Federhern.



Accession For	
NTIS GRA&I	<input checked="" type="checkbox"/>
DTIC TAB	<input type="checkbox"/>
Unannounced	<input type="checkbox"/>
Justification	
By _____	
Distribution/	
Availability Codes	
Dist	Avail and/or Special
A-1	

¹ *Options to Improve the European Theater Air Command and Control System*, Contract MDA 903-89-C-0003, Task T-J1-684, Amendment 3, November 1990, UNCLASSIFIED.

UNCLASSIFIED

(This page intentionally left blank.)

UNCLASSIFIED

UNCLASSIFIED

CONTENTS

Glossary xiii

Part 1 Introduction and Summary

Introduction

A. Background..... 1
B. Objective 4
C. Scope 5
D. Approach..... 5
E. Organization of the Report..... 7

Summary

A. Background..... 9
B. ACCS Communications Architecture..... 9
C. Baseline Communications Systems..... 10
D. Communications Issues 11
E. Availability of Communications for ACCS 12
F. Conclusions..... 13
G. Recommendations..... 15

Part 2 Discussion

A. ACCS Organization and Planning..... 17
B. The ACCS Generic Communications Architecture..... 22

UNCLASSIFIED

C. Baseline for Ground Area Communications 28

- 1. NATO-Owned Communications Systems..... 28
- 2. National Military Communications Systems in the CR and 5ATAF 29
- 3. The Defense Communications System (DCS) 34
- 4. Comparison of National Military Communications Networks..... 35

D. Communications Availability to Support ACCS 35

- 1. Determining Communications Availability 35
- 2. Transmission Plant Availability..... 36
- 3. Digital Voice Circuit Switch Availability 42
- 4. ACCS Packet Data Switch Availability 42
- 5. Data Exchange Standards..... 45
- 6. ACCS Management Issues..... 46
- 7. Transition Issues 47

E. Conclusions and Recommendations 47

- 1. Conclusions..... 47
- 2. Recommendations..... 49

Part 3 Analyses

I. ACCS ORGANIZATION AND PLANNING 51

- A. ACCS Organizational Structure..... 51
- B. Central Region..... 58
- C. Fifth Allied Tactical Air Force (5ATAF)..... 68
- D. Transition Planning 72

II. THE ACCS GENERIC COMMUNICATIONS ARCHITECTURE 77

- A. The ACCS Overall Concept for Command and Control..... 77
- B. The ACCS Communications Concept 77
- C. The Ground-Air-Ground Communications Subsystem..... 86
- D. The Maritime Communications Subsystem 87
- E. Communications Transition Considerations 89

UNCLASSIFIED

III. BASELINE SYSTEMS FOR GROUND-GROUND COMMUNICATIONS 93

A. NATO-Owned Communications Systems..... 93

 1. The NATO Integrated Communications System (NICS) 93

 2. The NATO Terrestrial Transmission System (NTTS) 94

 3. The CIP 67 Network..... 95

B. National Communications Systems in the Central Region 97

 1. Introduction 97

 2. The German Air Force Automated Communications System (GAFACS)..... 98

 3. The German Federal Armed Forces Integrated Services Digital Network (FAF ISDN) 100

 4. The Belgian Military Communications (BEMILCOM) Network 100

 5. The Netherlands Automatic Switched Communications Network (ASCON)..... 103

 6. The Netherlands Armed Forces Integrated Network (NAFIN)..... 103

C. National Communications Systems in 5ATAF 106

 1. Introduction 106

 2. Italian Baseline Communications 106

D. The Defense Communications System (DCS)..... 108

E. Comparison of National Military Communications Networks..... 108

IV. COMMUNICATIONS AVAILABILITY TO SUPPORT ACCS 113

A. Communications Funding Availability Within NATO 113

B. Determining Communications Availability 113

C. Transmission Plant Availability..... 115

D. Digital Voice Circuit Switch Availability 123

E. ACCS Packet Data Switch Availability 123

F. Data Exchange Standards..... 125

G. ACCS Management Issues..... 129

H. Transition Issues 130

UNCLASSIFIED

V. CONCLUSIONS AND RECOMMENDATIONS 133
 A. Conclusions..... 133
 B. Recommendations..... 135

References 137

Appendixes

- A. Task Background, Objective, and Statement of Work
- B. Approved Distribution List for IDA Paper P-2570

UNCLASSIFIED

LIST OF FIGURES

1.	Task Approach Outline.....	6
2.	Existing and Planned NATO Air C ² Systems.....	20
3.	ACCS Communications Architecture	24
4.	Planned NTTS Network Topology.....	30
5.	Digital Transmission Availability for ACCS in Germany.....	37
6.	Digital Transmission Availability for ACCS in Belgium.....	38
7.	Digital Transmission Availability for ACCS in the Netherlands	39
8.	Digital Transmission Availability for ACCS in 5ATAF.....	40
9.	Functional System Design Approach.....	52
10.	NATO Air C ² System.....	54
11.	Existing and Planned NATO Air C ² Systems.....	57
12.	Schematic Representation of Typical ACCS Entity.....	59
13.	Central Region Command Structure.....	61
14.	ACCS Headquarters Locations in the Central Region.....	62
15.	Air Control Centre Locations in the CR.....	63
16.	2ATAF Organization	66
17.	4ATAF Organization	67
18.	5ATAF Organization	69
19.	ACCS Headquarters Locations in 5ATAF.....	70
20.	ACC, ACU, and Other ACCS Locations in 5ATAF	71
21.	Schematic Representation of RAP Generation in the ACCS	78
22.	ACCS Communications Architecture	80

UNCLASSIFIED

23.	Ground-Air-Ground Communications.....	88
24.	The ACCS Ship-Shore Tactical Interface Component	89
25.	Planned NTTS Network Topology.....	96
26.	GAFACS Network with Military (LOS Radio) Trunk Connectivity.....	99
27.	FAF ISDN Communications System	101
28.	BEMILCOM Network	102
29.	ASCON Communications System.....	104
30.	NAFIN Communications System (Conceptual Topology).....	105
31.	First Phase Digitalization of ITSN.....	109
32.	Final Digital ITSN (DITSN) Configuration	110
33.	NATO Funding Eligibility Concept for ACCS Communications.....	114
34.	Digital Transmission Availability for ACCS in Germany.....	116
35.	Digital Transmission Availability for ACCS in Belgium.....	117
36.	Digital Transmission Availability for ACCS in the Netherlands.....	118
37.	Digital Transmission Availability for ACCS in 5ATAF.....	119
38.	ACCS Entities in the Baltic Approaches (BALTAP).....	121
39.	ACCS Entities in France.....	121
40.	Information Exchange Requirements (IER)	127
41.	ADSIA, SHAPE, ACCS IMG Co-operative for the Development of ACCS IERs	128

UNCLASSIFIED

LIST OF TABLES

1.	ACCS Entities Under the CAOC	10
2.	National Military Communications in the CR and 5ATAF	11
3.	Availability of Communications to Support ACCS.....	13
4.	ACCS Entities to be Implemented in the CR and 5ATAF During Phase I Transition (1991-1996).....	22
5.	Data Link Transition Strategy	27
6.	Comparison of National Military Communications Networks	35
7.	Transmission Trunk Availability.....	43
8.	Agencies responsible for ACCS Information Exchange	46
9.	Planned ACCs and ACUs in the CR.....	64
10.	Planned ATCRUs in the CR	64
11.	Planned Surveillance Entities in the CR.....	65
12.	NATO-Funded ACCS Elements in the CR and 5ATAF	74
13.	Comparison of ACCS Entity Plans for the CR and 5ATAF.....	75
14.	Data Link Transition Strategy	91
15.	Comparison of National Military Communications Networks	111
16.	Transmission Trunk Availability.....	123
17.	Agencies Responsible for ACCS Information Transfer.....	130
18.	Availability of Communications to Support ACCS.....	135

UNCLASSIFIED

(This page intentionally left blank.)

UNCLASSIFIED

UNCLASSIFIED

GLOSSARY

2ATAF	Second Allied Tactical Air Force
4ATAF	Fourth Allied Tactical Air Force
5ATAF	Fifth Allied Tactical Air Force
AAFCE	Allied Air Forces Central Europe
ACC	Air Control Centre
ACCHAN	Allied Command Channel
ACCS	Air Command and Control System
ACCST	Air Command and Control System Team
ACE	Allied Command Europe
ACLANT	Allied Command Atlantic
ACP	Allied Communications Publication
ACU	Air Control Unit
ADOLT	Air Defence Operations Liaison Team
ADPG	Air Defence Planning Group
ADSIA	Allied Data Systems Interoperability Agency
AEW	Airborne Early Warning
AFCENT	Allied Forces Central Europe
AIRBALTAP	Air Forces Baltic Approaches
ALO	Air Liaison Officer
AMC	Air Mission Control
AOCC	Air Operations Coordination Centre
AOR	Area of Responsibility
ASCON	Automatic Switched Communications Network
ASM	Airspace Management
ASOC	Air Support Operations Centre
ATAF	Allied Tactical Air Force
ATC	Air Traffic Control
ATCC	Air Traffic Control Centre
ATCCIS	Army Tactical Command and Control Information System
ATCRU	Air Traffic Control Radar Unit
ATOC	Air Tasking Operations Centre
AWHQ	Alternate War Headquarters
BALTAP	Baltic Approaches
BE	Belgium
BEMILCOM	Belgian Military Communications (Network)
BEMILDAT	Belgian Military Data (System)
BICES	Battlefield Information Collection and Exploitation System
bps	Bits Per Second
C ²	Command and Control
C2RM	Command and Control Resource Management

UNCLASSIFIED

C ³	Command, Control and Communications
CAOC	Combined Air Operations Centre
CBC	Cross-Border Connection
CCIR	Comite Consultatif International des Radio-Communications
CCITT	Consultative Committee on International Telegraph and Telephone
CENTAG	Central Army Group
CINCENT	Commander-in-Chief, Central Europe
CINCHAN	Commander-in-Chief Channel
CIP	Communications Improvement Program
CFE	Conventional Forces in Europe
COMAAFCE	Commander Allied Air Forces Central Europe
COMBALTAP	Commander Baltic Approaches Communications
COMM	Communications
COMNORTHAG	Commander Northern Army Group
COMTWOATAF	Commander 2ATAF
CR	Central Region
CRC	Control and Reporting Centre
CRP	Control and Reporting Post
CVSD	Continuously Variable Slope Delta (Modulation)
DA	Denmark
DCA	Defense Communications Agency
DCS	Defense Communications System
DDN	Defense Digital Network
DEB	Digital European Backbone
DITSN	Digital Italian Tri-Service Network
DNS	Direct NICS Subscriber
ECCM	Electronic Counter Counter-Measures
ECM	Electronic Counter-Measures
ESM	Electronic Support Measures
ETACCS	European Theater Air Command and Control Study
FAC	Forward Air Controller
FAF ISDN	Federal Armed Forces Integrated Services Digital Network (Germany)
FLOT	Forward Line of Troops
FM	Frequency Modulation
FOC	Final Operating Capability
FR	France
FRG	Federal Republic of Germany
GAF	German Air Force
GAFACS	Germany Air Force Communications System
G-A-G	Ground-Air-Ground
GDR	German Democratic Republic
GE	Germany
GHz	Gigahertz
GR	Greece

UNCLASSIFIED

HF	High Frequency
HQ	Headquarters
IA	Integral ACCS
IAU	Infrastructure Accounting Unit
ID	Identification
IDA	Institute for Defense Analyses
IER	Information Exchange Requirement
IFF	Identification Friend or Foe
IJMS	Interim JTIDS Message Specification
IMG	Interim Management Group
INEX	Information Exchange
INS	Indirect NICS Subscriber
IOC	Initial Operating Capability
ISDN	Integrated Services Digital Network
ISO	International Standards Organization
IT	Italy
ITA	International Telegraphic Agency
ITSN	Italian Tri-Service Network
ITT	International Telephone and Telegraph
IVSN	Initial Voice Switched Network
JTIDS	Joint Tactical Information Distribution System
kbps	Kilobits Per Second
LAN	Local Area Network
LISA	Link in Support of ACCS
LOS	Line of Sight
LU	Luxembourg
MAOC	Maritime Air Operations Centre
MAS	Military Agency for Standardization
MASSTIC	Maritime ACCS Ship and Shore Tactical Interface Component
MBDL	Missile Battery Data Link
Mbps	Megabits Per Second
MCE	Modular Control Equipment
MIAU	Million Infrastructure Accounting Units
MIDS	Multifunctional Information Distribution System
MNC	Major NATO Command
MOR	Military Operational Requirement
MRT	Multi-Radar Tracking
MSC	Major Subordinate Command
MST	Multi-Sensor Tracking
NACISA	NATO Communications and Information Systems Agency
NACISC	NATO Communications and Information Systems Committee
NACMA	NATO ACCS Management Agency
NACMO	NATO ACCS Management Organization

UNCLASSIFIED

NADC	NATO Air Defence Committee
NADEEC	NATO Air Defense Electronic Environment Committee
NADGE	NATO Air Defence Ground Environment
NAEW	NATO Airborne Early Warning
NAFIN	Netherlands Armed Forces Integrated Network
NATO	North Atlantic Treaty Organization
NCIS	NATO Common Interface Standards
NICS	NATO Integrated Communications System]
NIMP	NATO Interoperability Management Plan
NL	Netherlands
NO	Norway
NORTHAG	Northern Army Group
NPIS	NATO Procedural Interoperability Standards
NTTS	NATO Terrestrial Transmission System
OSI	Open Systems Interconnection
PABX	Private Automatic Branch Exchange
PAMCS	Panel on Airspace Management and Control Systems
PCM	Pulse Code Modulation
PO	Portugal
PWHQ	Primary War Headquarters
PSC	Principal Subordinate Command
PSWHQ	Primary Static War Headquarters
PTT	Postal, Telephone, and Telegraph
RAP	Recognized Air Picture
RNLAF	Royal Netherlands Air Force
RP	Radar Post
RPC	RAP Production Centre
S	Surveillance
SACEUR	Supreme Allied Commander, Europe
SAM	Surface-to-Air Missile
SAMOC	SAM Operations Centre
SATCOM	Satellite Communications
SCARS	Status, Control Alerting, and Reporting System
SD	Supporting Document
SFP	Sensor Fusion Post
SHAPE	Supreme Headquarters Allied Powers Europe
SHF	Super High Frequency
SHOC	SHAPE Operations Center
SOC	Sector Operations Centre
SP	Spain
SPM	Source Probability Matrix
SQOC	Squadron Operations Centre
SSSB	Ship-Shore-Ship Buffer
STANAG	Standardization Agreement
STC	SHAPE Technical Centre
STRIDA	Systeme de Transmission et de Representation des Informations de Defense Aerienne
STU	Secure Terminal Unit

UNCLASSIFIED

SW	Switched
SWG(T)	Special Working Group (Transition)
TACP	Tactical Air Control Party
TADIL	Tactical Digital Information Link
TARE	Telegraph Automatic Relay Equipment
TBD	To Be Determined
TCIS	Technical Common Interface Standards
TDM	Time Division Multiplexing
TRI-MNC	Tri-Major NATO Commands (ACE, ACLANT, and ACCHAN)
TSGCEE	Tri-Service Group on Communications-Electronics Equipment
TTY	Teletypewriter
TU	Turkey
UHF	Ultra-High Frequency
UK	United Kingdom
UKADGE	UK Air Defence Ground Environment
US	United States
VHF	Very High Frequency
WG	Working Group
WG-4	Working Group Four
WOC	Wing Operations Centre

UNCLASSIFIED

(This page intentionally left blank.)

UNCLASSIFIED

UNCLASSIFIED

Part 1

INTRODUCTION AND SUMMARY

UNCLASSIFIED

UNCLASSIFIED

INTRODUCTION

A. BACKGROUND

NATO has long recognized the inadequacies of its existing air command and control system and has developed a cohesive long-term program to integrate air command and control assets into an overall effective, automated system. The need for an improved integrated system was also driven by the increasing capabilities and sophistication of aircraft and weapons systems of both the Warsaw Pact and Allied forces. The increasing threat from the Warsaw Pact forces, coupled with high weapon system costs, dictated that efficient, effective use had to be made of limited Allied air assets.

Accordingly, in late 1979, NATO approved an Air Defence Planning Group (ADPG) report entitled "The Refined Program for Air Defence in Allied Command Europe." This report concluded, in part, that for NATO to put its limited and expensive aircraft and weapon system resources, to best use, it must modernize its air command, support, and defensive resources, including the many sensors installed throughout NATO and integrate them into an overall air command and control system. The modernization was to include the integration of air defense with tactical air control and support functions. The report also called for the modernization of sensors, communications, and command and control centers. To implement this effort, the NATO Air Defense Committee (NADC) reorganized the NATO Air Defense Electronic Environment Committee (NADEEC), establishing it as the Panel on the Airspace Management and Control Systems (PAMCS). The NADC requested the panel to organize and oversee the realization of the NATO Air Command and Control System (ACCS). The PAMCS subsequently developed a design team organization with central offices in Brussels. All NATO nations agreed to contribute personnel to the team, and in September 1981 the PAMCS began to form a full-time team. This team comprised national experts representing 11 different nations including the United States.

The United States contributed one U.S. Air Force and six civilian representatives. Also, SHAPE agreed to and staffed a Major NATO Command (MNC) cell

UNCLASSIFIED

UNCLASSIFIED

collocated with the team to provide liaison. The team, called the Air Command and Control System Team (ACCST), was formed and began detailed design work in March 1982.

The ACCST was tasked to develop an overall ACCS design based on the SHAPE/MNC Military Operational Requirements (MOR). The design was developed in two main steps:

- **Requirements Analysis** - The ACCST analyzed the requirements and translated them into the desired military capabilities/goals documented in Volume I of the ACCS Master Plan. A comparison of desired goals with the baseline (1985) existing systems was documented in Volume II. This determined the needs and priorities documented in Volume III.
- **System Design** - Needs and priorities were translated in terms of functional capabilities and the operational structure into a generic design that is documented in Volume IV and its supporting documents. The generic design contained various survivability measures such as mobility and geographic dispersion of ACCS elements. The result was a revised operational structure composed of fixed and mobile entities. When the generic design was applied to the various regions, modifications to meet unique regional needs were made and reflected in the 10 regional design supplements to Volume IV.

As a part of the design, NATO directed that the ACCST provide an ACCS cost estimate. This costing requirement was a source of controversy when deciding the design approach. Within the NATO community, SHAPE technical agencies heavily favored a design-to-cost approach whereby the design cost could not exceed a fixed amount of funds per slice (year) over an 18-year period. These agencies, however, could not provide guidance concerning what this fixed amount should be. The ACCST decided, in view of the lack of funding guidance, that the prudent course of action was to design the system needed to meet the SHAPE MOR. This design would then be costed. This is referred to as the cost-unconstrained approach. When the design was completed and costed, it would then be measured against NATO and the nations' ability to fund their respective parts. The system design would then be constrained, as required, to meet funding capabilities. The military risks incurred by this approach and any resulting system reduction could then be estimated. This design approach was approved by the PAMCS. Once the design was completed and published as the ACCS Master Plan, the ACCST was disestablished and the task of preparing system specifications was transferred to a newly established Interim Management Group (IMG).

UNCLASSIFIED

The ACCS design was based on the SHAPE requirement to provide effective management and employment of SACEUR's air resources in time of war. This included the harmonization of air operations with ACE ground activities and with maritime operations in the sea areas adjoining ACE. The ACCS was required to support air operations planning, tasking, and execution from MNC level down to combat unit level. The design concentration was, however, below the Principal Subordinate Command (PSC) level, which is the Allied Tactical Air Force (ATAF) area. The major design goal was to use effectively all available sensor data from any source within and adjacent to the ATAF, and to integrate the tasking of offensive, defensive, and support air missions. The design included surface-to-air missile (SAM) employment, and the entire system was to be operational throughout ACE by the year 2002. Adequate air C² capability had to be maintained through the transition and the design had to be affordable in both cost and manpower. The ACCS design emphasis was on wartime operations, yet the system was required to support air C² functions in peacetime and times of tension. It also had to be capable of rapid transitioning between these conditions. The primary characteristics of air command and control in times of peace, tension, and war are:

- Peace -- Adherence to high standards of air safety, support of air policing, capability to provide early warning surveillance, need for training facilities, and ability to support large-scale exercises
- Times of tension -- Maintenance of highly centralized operational command in order to control potential actions and manage any required buildup activities
- War -- Centralized control of assets but decentralized execution; maintenance of operation in the face of efforts to degrade the system through physical and electronic damage.

The ACCST design effort is documented in the ACCS Master Plan. The plan establishes a comprehensive design for all phases of the modernization of existing NATO air defense systems and integrates air defense, offense, and support. The ACCS Master Plan clearly emphasizes that ACCS is communications-intensive and that the communications subsystem is an essential component of the command and control system. This means that effective, timely communications must be available prior to, or at the time of, establishing ACCS entities. The communications system that interconnects ACCS must provide Recognized Air Picture (RAP) data to users in real time and update this data every five seconds continuously. Additionally, the communications system must transfer track data from sensors and other sources such as Airborne Early Warning (AEW) and maritime platforms in real time to be processed and formed into the RAP. The effectiveness of

UNCLASSIFIED

ACCS depends upon the production, timely updating, and distribution of RAP data, which in turn enables the air war to be conducted.

To develop an affordable ACCS transition plan, NATO formed the Special Working Group (Transition) [SWG(T)], which developed a cost-constrained transition plan for the period 1991-1996 (Phase I). However, recent events in the Soviet Union and Eastern Europe soon overtook the Phase I Transition Plan. Significant progress in the Conventional Forces in Europe (CFE) treaty process and concurrent moves towards reductions in defense budgets have significantly altered the tactical air situation in NATO. The clear physical division between East and West previously formed by the Warsaw Treaty Organization (Warsaw Pact) no longer exists. Warning times have dramatically increased, so NATO forces will not be required to maintain the same state of readiness or availability as before. As it draws down its military forces, the Soviet Union will no longer have the capability to attack simultaneously across the entire NATO front. To assess the impact of a post-CFE Europe on ACCS, NATO has formed a special team (known as ORACLE) which is currently reassessing the ACCS concept and determining post-CFE ACCS requirements. A more mobile ACCS, with fewer entities, is likely to emerge from this process.

B. OBJECTIVE

As part of Task 4 of the European Theater Air Command and Control Study (ETACCS), the sponsor requested an analysis of the Central Region and 5ATAF (Italy) communications infrastructure planned to support the ACCS in order to determine if adequate communications would be available to support planned ACCS entities. The basis for the analysis is the *ACCS Master Plan, Volume IV: Overall ACCS Design; Generic Portion* and its attendant regional supplements. The objective of this task is to compare the communications subsystems required by the ACCS Master Plan with the present and planned NATO/national communications systems and document the status of these communications systems planned in the Central Region and 5ATAF over the period 1991-1997 and beyond. Secondary objectives are to analyze the degree to which these NATO/national capabilities satisfy the planned ACCS implementation program, identify discrepancies and shortcomings, and make recommendations concerning the desirability of maintaining or modifying the timing of the ACCS system implementation and the installation of entities.

UNCLASSIFIED

C. SCOPE

This report investigates the ground-to-ground communications capabilities of the NATO Central Region (Belgium, the Netherlands, and the Federal Republic of Germany) and 5ATAF (Italy). Each of these four countries is building or upgrading national military digital communications systems which will host ACCS communications; these countries will be among the first to implement ACCS entities on their territories.

The communications requirements for ACCS are as stated in the ACCS Master Plan and the regional supplements for the Central Region and 5ATAF. The NATO ACCS Management Organization (NACMO) Statement of Work and the NATO C³ Transition Plan provide the status of ACCS planning and funding and the timing of implementation of new ACCS entities. This timing is compared to the NATO/national military communications network availability in the Central Region and 5ATAF.

The new look at ACCS by NATO's ORACLE team which resulted from the CFE process occurred after this study was well underway. Since NATO has not yet determined what the post-CFE ACCS will be, this study is based upon the original ACCS Master Plan and the Phase I Transition Plan, even though those documents have been overtaken by events. Further study would be required to determine communications availability for a post-CFE ACCS, but this report should provide a good point of departure for such an effort.

D. APPROACH

The overall approach to the task is depicted in Figure 1.

The assessment of the ability of Central Region and 5ATAF communications to support ACCS starts with a review of the communications portion of the ACCS Master Plan. The Central Region and 5ATAF supplements to this plan contain region-dependent architectures designed to perform the ACCS functions and to satisfy ACCS communications needs.

Next, the ACCS transition is reviewed to determine the location and scheduling of ACCS entities for installation within the Central Region and 5ATAF. The planned ACCS procurements as programmed by SHAPE for inclusion in the NATO six-year budget document "SACEUR's Infrastructure Plan" in the category "Warning Installation" is analyzed. Each budget year is presented as a yearly funding profile. The document contains the ACCS entities that will be procured and the funds allocated.

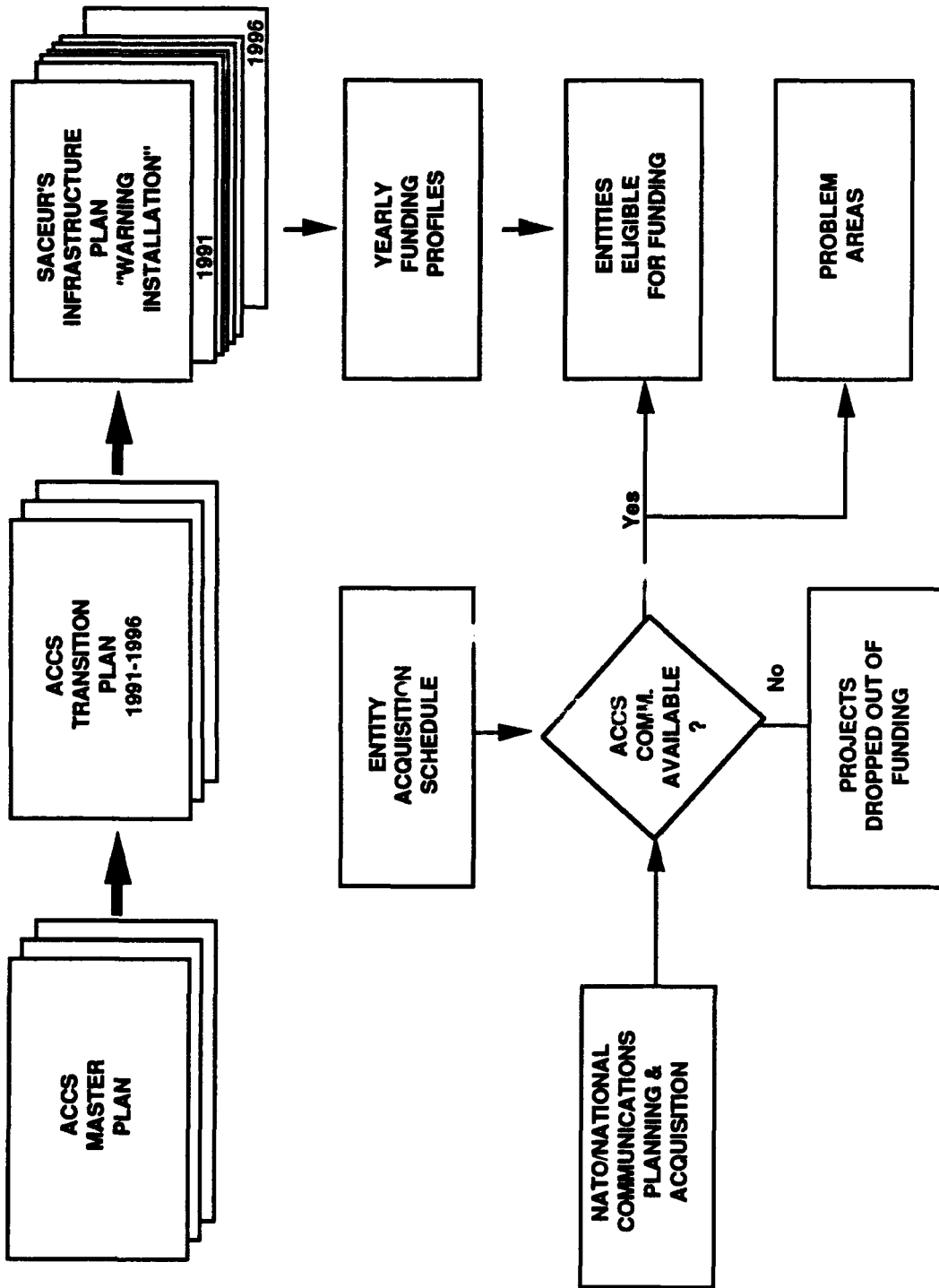

Figure 1. Task Approach Outline

UNCLASSIFIED

An analysis of the planned NATO communications acquisitions and the planned national procurements is then performed. This determines: (1) the communications capabilities that will be available to support ACCS and (2) the schedule by which this capability will be available.

The planned communications capability is compared with the ACCS entity acquisition schedule in the Central Region and 5ATAF. If the communications capability will not exist to support ACCS, the entity project is recommended to be deleted from funding and the funds used for other entities. If the needed communications will be available, the entity project is recommended for support. Problem areas are identified, analyzed, and appropriate action or alternatives are recommended.

The sources of information are primarily the documents listed in the references. Supplemental information was gathered from such agencies as the U.S. Defense Communications Agency (DCA) -- now known as the Defense Information Systems Agency (DISA), NATO Headquarters, Interim Management Group/NATO ACCS Management Agency (IMG/NACMA), NATO Communications Information Systems Agency (NACISA), and national sources.

E. ORGANIZATION OF THE REPORT

Part 1 of this report includes the Introduction and a brief Summary of the principal findings and recommendations. Part 2 is a Discussion of the data, analyses, and results, and is intended to be a short document that stands alone. Part 3 is a complete description of the Analyses which support the recommendations.

Within the Analyses section, the ACCS organizational structure and information flow within the Central Region and 5ATAF is presented, followed by an outline version of the transition plan for implementing ACCS in these areas. Next, in light of the generic communications requirements for the ACCS, the baseline systems for satisfying the architecture within both the Central Region and 5ATAF are explored. An assessment is then made of the capability of the baseline and planned communications systems to support the architecture during the time frame of the ACCS transition by comparing their capabilities and probable schedules with those of the ACCS. Technical interoperability problems are explored. Lastly, conclusions are drawn and recommendations made.

UNCLASSIFIED

(This page intentionally left blank.)

UNCLASSIFIED

UNCLASSIFIED

SUMMARY

A. BACKGROUND

The ACCS development followed a functional approach. This produced a modular structure that permits more flexibility than the current air command and control structure. The new design integrates air offense, air defense, and air support operations under a single entity, the Combined Air Operations Centre (CAOC). The CAOC replaces both the Air Tactical Operations Centre (ATOC) and Sector Operations Centre (SOC). Airspace control and air surveillance, which are currently consolidated under the SOC and its sub-entities, will be functionally separated under the CAOC. Sensors will be netted and their data fused, resulting in more information and faster air track update times. The air track data will be widely distributed throughout the ACCS as a Recognized Air Picture (RAP) in near-real time. In addition to the CAOC, the ACCS contains a number of new entities. These entities, together with the functions they perform, are shown in Table 1. The CAOCs and their subordinate ACCS entities operate under Allied Tactical Air Forces (ATAF): 2ATAF and 4ATAF in the Central Region (CR), and 5ATAF in Italy.

B. ACCS COMMUNICATIONS ARCHITECTURE

The ACCS communications architecture reflects the need for modern secure voice, record, and data systems to satisfy ACCS information exchange requirements. These systems will replace the maze of dedicated point-to-point circuits currently used for air command and control. For voice and record, the needlines are similar to current requirements, but a digital transmission system is required for voice to accommodate bulk encryption. Data needlines for RAP distribution are also similar to current requirements, but the volume will be much higher and the information must be delivered in near-real time to satisfy the 5-second update requirement. A digital packet-switched network is therefore required to replace Link 1 and distribute the RAP. This network may have to be dedicated to ACCS use to meet the very rapid delivery times to multiple addresses.

UNCLASSIFIED

Table 1. ACCS Entities Under the CAOC

ACCS Entity	Function Performed
Air Control Centre (ACC)	Air mission control and battle management
Air Control Unit (ACU)	Same as ACC, less SAM control
Sensor Fusion Post (SFP)	Control of sensors, fusion of data, establishment of local air tracks
Recognized Air Picture (RAP) Production Centre (RPC)	Track management and identification, RAP production and distribution
Air Operations Coordination Centre (AOCC)	Coordination of air operations with Army ground and air operations
Maritime ACCS Shore and Ship Tactical Interface Component (MASSTIC)	Tactical information exchange between ACCs and naval forces afloat
Wing Operations Centre (WOC)	Control of airbase/airfield operations
Air Traffic Control Radar Unit (ATCRU)	Military Air Traffic Control
Surface-to-Air Missile Operations Centre (SAMOC)	Control of mixed SAM systems (Central Region only)

For transmission, the new voice and data networks will depend upon new digital communications systems being procured by the individual nations and by NATO. There are no other options, since the older analog systems cannot support the new digital requirements and the Postal, Telegraph, and Telephone (PTT) commercial facilities of the nations are, for security and survivability reasons, to be used only as backup.

C. BASELINE COMMUNICATIONS SYSTEMS

NATO-owned communications systems include the NATO Integrated Communications System (NICS) and such aging transmission systems as ACE HIGH and Communications Improvement Program 67 (CIP 67). NICS includes a non-secure switched voice system with a narrowband secure voice overlay, and a store-and-forward switched message system. The present NICS can support some ACCS common-user requirements, but not the ACCS-unique requirements. NICS normally supports dedicated requirements at the Principal Subordinate Command (PSC) level and above. The preponderance of ACCS communications requirements are below the PSC level.

NATO is planning to replace the mostly analog, mostly single-thread ACE HIGH transmission system with a new, meshed digital system over the next ten years. The new system, called the NATO Terrestrial Transmission System (NTTS), will consist of a network of 2 Mbps digital trunks furnished by the individual NATO nations from their

UNCLASSIFIED

existing or new digital military systems, and 2 Mbps Cross-Border Connections (CBC) furnished by NATO headquarters. The NTTS would technically be able to support ACCS transmission requirements, but it is intended for users at PSC level and above. If the capacity is available on either the trunks or the CBCs, it is possible that some ACCS requirements below PSC level could be supported by the NTTS.

However, it appears that most ACCS requirements must be supported by the military communications systems of the individual NATO nations, as air command and control requirements are now. Table 2 shows the national systems which might be used in the CR and 5ATAF, along with approximate dates of their availability for ACCS use.

Table 2. National Military Communications In the CR and 5ATAF

Country	Acronym	National Military COMMS System	Date Avail.
Belgium	BEMILCOM	Belgian Military Communications Network	Current-1993
Germany	GAFACS	German Air Force Automated Communications System	1992
Germany	FAF ISDN	Federal Armed Forces Integrated Services Digital Network	1993-1999
Italy	DITSN	Digital Italian Tri-Service Network	1991-2000
Netherlands	ASCON	Automatic Switched Communications Network	Current
Netherlands	NAFIN	Netherlands Armed Forces Integrated Network	1996
United States	DEB/DCS	Digital European Backbone, Defense Communications System	Current

D. COMMUNICATIONS ISSUES

Most of the new systems will conform to European digital CCITT transmission standards (2.048 Mbps trunks, with 30 channels of 64 kbps each) and use CCITT Signalling System #7 and will thus be interoperable on a trunk-to-trunk basis. However, some of the networks will not be interoperable without the use of gateways. GAFACS, for instance, uses the ITT System 12 signaling standard. ASCON uses North American transmission standards (1.544 kbps T-1 trunks, with 24 channels of 56 kbps each, plus 8 kbps for signaling), as does the U.S. Defense Communications System (DCS). The DCS, which might conceivably provide some space for ACCS, already has gateways for interfacing with European systems.

UNCLASSIFIED

There are other standards and interoperability problems as well. Ground-air-ground and maritime communications subsystems must be interfaced with the ACCS ground-ground system. Packet switching systems must adhere to common standards. The effective integration of all types of ACCS messages on the data communications network requires a standardization of message formats, catalogs, and protocols. The Allied Data Systems Interoperability Agency (ADSIA) is developing a standard based on J-Series messages, but this effort must be carefully coordinated to maintain interoperability between all parts of the communications system, and to ensure the availability of the data messages for ACCS entities when installed. A 20-month contract to develop Information Exchange Requirements (IER) for these standards was awarded in January 1991.

There has been no progress towards development of packet data transmission standards. The Tri-Service Group on Communications-Electronics Equipment (TSGCEE), the organization responsible for the standards, has not even been tasked to do the job. Of particular concern is how the RAP messages are to be handled. Must the RAP be sent individually to each user, or can it be sent once, with multiple user addresses? Multiple address protocols are not currently available for packet switching.

E. AVAILABILITY OF COMMUNICATIONS FOR ACCS

Table 3 summarizes the availability of communications to support the ACCS Phase I Transition entities. The following definitions apply to the degrees of risk shown in the table:

- **HIGH RISK:** Will pace ACCS implementation unless immediate action is taken and followed through.
- **MEDIUM RISK:** Will slow ACCS implementation unless action taken soon and carefully monitored.
- **LOW RISK (not applicable on this table):** Will not slow ACCS implementation if current efforts are continued.

UNCLASSIFIED

Table 3. Availability of Communications to Support ACCS

Necessary Element	Degree of Risk		Remarks
	High	Medium	
Transmission Systems		√	Disimilar standards require gateways for GAFACS & ASCON. CBCs not assured.
Digital Voice Circuit Switching		√	Interfaces required between some national military systems.
Packet Data Switching	√		No known plans for the most critical ACCS communications requirement.
Data Exchange Standards		√	IERs not available until Sept. 1992. ADSIA WG-4 working on message standards. Work on transmission protocols not begun.
Total System Management		√	Difficult to coordinate/control multiple agencies. No coordinated implementation plan exists.

F. CONCLUSIONS

ACCS is a very communications-intensive acquisition. Communications is so much a part of the total system that it would be foolish to deploy a new ACCS entity unless the communications elements to support it are in place by the time the entity is expected to be operational.

ACCS demands more modern communications networks than are currently in place throughout the Central Region and 5ATAF. The transmission systems must be digital to support secure voice and high data rates. A packet switching system is necessary to handle and distribute the near-real-time air track data. The data switching network for air track data may have to be dedicated to ACCS since it is such an ACCS-unique requirement. The character-oriented general data traffic and the digital voice can, in all probability, be supported by national packet-data-switched and circuit-switched systems. Here, however, complete interoperability for data and voice signaling must be assured. Currently it is not assured. ACCS cannot be implemented until these transmission and switching networks are in place, and unless each of the networks is interoperable with like networks in adjacent regions.

There are no budgeting or planning data concerning the procurement of packet data switches for ACCS, and yet these switches are required to realize a viable data exchange system between ACCS entities. This indicates that there may be a lack of intent to ever implement the critically needed ACCS packet switched data system to replace Link 1 and

UNCLASSIFIED

provide the required information exchange to integrate ACCS entities. The absence of planning or budgeting data is also evident in the case of voice circuit switches.

For digital transmission systems, ACCS will primarily depend upon national digital military networks which are being or have been installed in the Central Region and 5ATAF. The NTTS (which also depends on these national networks) may possibly carry some of the ACCS circuits. Cross-border connectivity of these transmission systems is also required, whether it be provided by bilateral agreements between nations, or through the CBCs of the NTTS.

The national military transmission systems and NTTS CBCs are expected to be available in time to support the ACCS entities in the Phase I Transition Programme in the CR and 5ATAF, but interfaces (gateways) will be required between some of the older and some of the newer networks because of dissimilar transmission and signaling standards. Further, there is no guarantee that the NTTS CBCs can be used by ACCS below PSC level.

To ensure computer-computer understanding and provide effective transmission of ACCS messages on the data communications network requires a standardization of data *message* formats into catalogs, data element dictionaries, and standard operating procedures (protocols). This work is underway, but the process will be long and complex. Additionally, data *transmission* protocols must be delivered and implemented. At issue here is what standards will be used and whether new ones will be required. In particular, the issue of a multiaddress standard requires attention.

Because there are numerous NATO agencies and committees involved in the planning, procurement and integration of ACCS communications support, it is difficult to understand all facets of ACCS communications. In general, there is no one agency to monitor and direct these efforts to ensure that they result in clearly-defined ACCS communications deliverables, in accordance with definite milestones, to meet scheduled needs. There is an urgent need for a single coordinated ACCS communications implementation plan that directs the many activities concerned towards the goal of ACCS data communications support by showing what is to be done, by whom, and by when.

With the significant reduction of the threat and concurrent reduction in funding, a new ACCS concept with considerably fewer entities (many of which are mobile) is under development by a SHAPE team known as ORACLE. This new ACCS concept could

UNCLASSIFIED

dramatically change the communications requirements. The principles that support the study will, however, remain valid even if the post-CFE world should yield new fundings.

G. RECOMMENDATIONS

Until budgeting plans, with implementation dates, are known for circuit and packet switched networks that can be used to support ACCS, *no* ACCS entities should be supported. The United States should maintain its stated position that the availability of communications (including required switching capabilities) is a prerequisite for supporting the acquisition of ACCS entities.

The preparation of the ACCS data message standards must be carefully coordinated to maintain interoperability between all parts of the communications system, and to ensure the availability of the data messages for ACCS entities when installed. Similarly, the preparation of multi-address data transmission standards must be started and carefully monitored. The TSGCEE should be tasked by NATO to begin work on these standards.

If not already doing so, NACMA should develop a coordinated, integrated communications implementation plan with milestones and ensure that everyone works toward the same goals and that the many ongoing efforts result in a communications system that can support ACCS.

Since post-CFE implications of ACCS and its communications were outside the scope of this study, further study would be required to determine communications available for ACCS under the ORACLE concept. This report could be used as a starting point for such an effort.

UNCLASSIFIED

(This page intentionally left blank.)

UNCLASSIFIED

UNCLASSIFIED

Part 2
DISCUSSION

UNCLASSIFIED

UNCLASSIFIED

DISCUSSION

NATO has long recognized existing air command and control system inadequacies and has developed a cohesive long-term program, the Air Command and Control System (ACCS), to integrate air command and control assets into an overall effective, automated system. The need for an improved integrated system was also driven by the increasing capabilities and sophistication of aircraft and weapons systems of the Soviet Union, the former Warsaw Pact, and Allied forces. This increasing threat, coupled with high weapon system costs, dictated that efficient, effective use had to be made of limited Allied air assets. The ACCS is, by design, a very communications-intensive system. The purpose of this report is to determine whether the supporting communications systems will be completed in time to provide communications for ACCS entities as they are implemented, and to explore communications problems which could hamper the transition to ACCS.

This report investigates the ground-to-ground communications capabilities of the NATO Central Region and 5ATAF, which include the four countries of Belgium, the Netherlands, the Federal Republic of Germany (FRG), and Italy. Each of the four countries and NATO is currently building or upgrading NATO/national military digital communications systems which can host ACCS communications. The communications requirements for ACCS are as stated in the ACCS Master Plan and the regional supplements for the Central Region and 5ATAF. The NATO ACCS Management Organization (NACMO) Statement of Work and the NATO C³ Transition Plan provide the status of ACCS planning and funding, and Volume IV of the Master Plan (Phase I Transition Programme) provides the timing of implementation of new ACCS entities during the next 6 years. This timing is compared to the NATO/national military communications network availability in the Central Region and 5ATAF.

A. ACCS ORGANIZATION AND PLANNING

The ACCS development followed a functional approach. This produced a modular structure that permits more flexibility than the current air command and control structure. The new design integrates air offense, air defense, and air support operations under a

UNCLASSIFIED

single entity, the **Combined Air Operations Centre (CAOC)**. The CAOC replaces both the **Air Tactical Operations Centre (ATOC)** and **Sector Operations Centre (SOC)**.

In addition to the CAOC, the ACCS contains a number of new entities. The major ones include:

- **Air Control Centre (ACC)** -- These entities provide degrees of control and control support for defensive air missions (including SAM) for offensive and for support air missions. ACCs constitute the main air mission control/ battle management capability.
- **Air Control Unit (ACU)** -- Subordinate to the ACCs, the ACUs are capable of providing the same battle management and air mission control capabilities as the ACC, with the exception of SAM control. ACUs are physically smaller entities, normally mobile, and primarily intended to fill gaps in air control.
- **Reporting Post (RP)** -- This surveillance entity, consisting of either an active or a passive sensor, detects, signal-processes, and forwards data on air objects to the Sensor Fusion Post (SFP).
- **Sensor Fusion Post (SFP)** -- This entity controls assigned RPs (up to a maximum of 12 sensors) with an additional capacity (of 12 sensors) for back-up purposes. The SFP fuses the data received from its attached RPs and establishes local tracks. The local track and identification data are forwarded to the next level for processing. The SFP does not make track identifications; this authority is reserved for the RPC.
- **Recognized Air Picture (RAP) Production Centre** -- This entity receives track data from its assigned SFPs, NAEW, maritime, and any other source that produces air tracks. In producing the RAP for its assigned AOR, the RPC performs track management, identifies targets, and assigns NATO track numbers. The RPC distributes the RAP data to all users. The RAP is proposed to be updated every 5 seconds.
- **Air Operations Coordination Centre (AOCC)** -- The ACCS entity proposed to provide an interface with Army forces, an AOCC (which replaces the current ASOC) is collocated with each Army corps headquarters and reports to a CAOC. It performs the function of coordinating air operations with Army ground and air operations.
- **Maritime ACCS Shore and Ship Tactical Interface Component (MASSTIC)** -- The MASSTIC provides tactical information exchange between the land-based ACCS and naval forces afloat.

UNCLASSIFIED

- **Wing Operations Centre (WOC)** -- The C² facility planned to control airbase/airfield operations, the WOC also distributes Recognized Air Picture (RAP) data to all airbase/airfield users. The Squadron Operations Centre (SQOC) performs a similar mission at the squadron level.
- **Air Traffic Control Radar Unit (ATCRU)** -- ATCRUs provide the basis for military air traffic control of non-combat and combat missions before entering and after leaving forward combat areas.
- **Surface-to-Air Missile Operations Centre (SAMOC)** -- Within the Central Region (CR) there is a large deployment of mixed SAM weapons. To control these different systems in the CR, the SAMOC is proposed. The SAMOC is a mobile unit functionally subordinate to the ACC and responsive to battle management functions performed at the CAOC/ACC.

The above ACCS entities are all execution-level C² centers below the CAOC.¹ As the CAOC subsumed the ATOC and SOC, other differences between ACCS and the existing structure emerged from the modular approach to organization. For instance, the Control and Reporting Centre (CRC) was functionally divided into its logical parts (ACC, RPC, and SFP). Figure 2 compares the ACCS organizational structure with the present organizational structure.

At the tasking level, the ACCS combines the air defense, air offense and air support functions into one single entity, the Combined Air Operations Centre (CAOC). At the execution level the proposed C² system functionally separates control and surveillance, which in the current system are combined in the SOC. In the ACCS the control function is performed by the Air Control Centre (ACC), the Air Control Unit (ACU), and the Wing Operations Centre (WOC). Surveillance starts at the sensors where both active and passive sensors are netted to the Sensor Fusion Post (SFP). Each SFP is capable of netting up to a total of 24 sensors. From this sensor data the SFP generates the local area picture. This picture together with correlated identification (ID) as well as non-correlated tracks is passed to the Recognized Air Picture (RAP) Production Centre (RPC). At the RPC these local area pictures are aggregated and correlated with information from other RPCs (track cross-tell), flight plans and other data stored in databases, and tracks coming from sources such as NATO air early warning (NAEW) and naval sensor platforms. After giving the track an

¹ The CAOC itself is subordinate to an Allied Tactical Air Force (ATAF). The Central Region has two ATAFs: 2ATAF in Northern Germany, Belgium, and the Netherlands; and 4ATAF in Southern Germany. 5ATAF covers the whole of Italy.

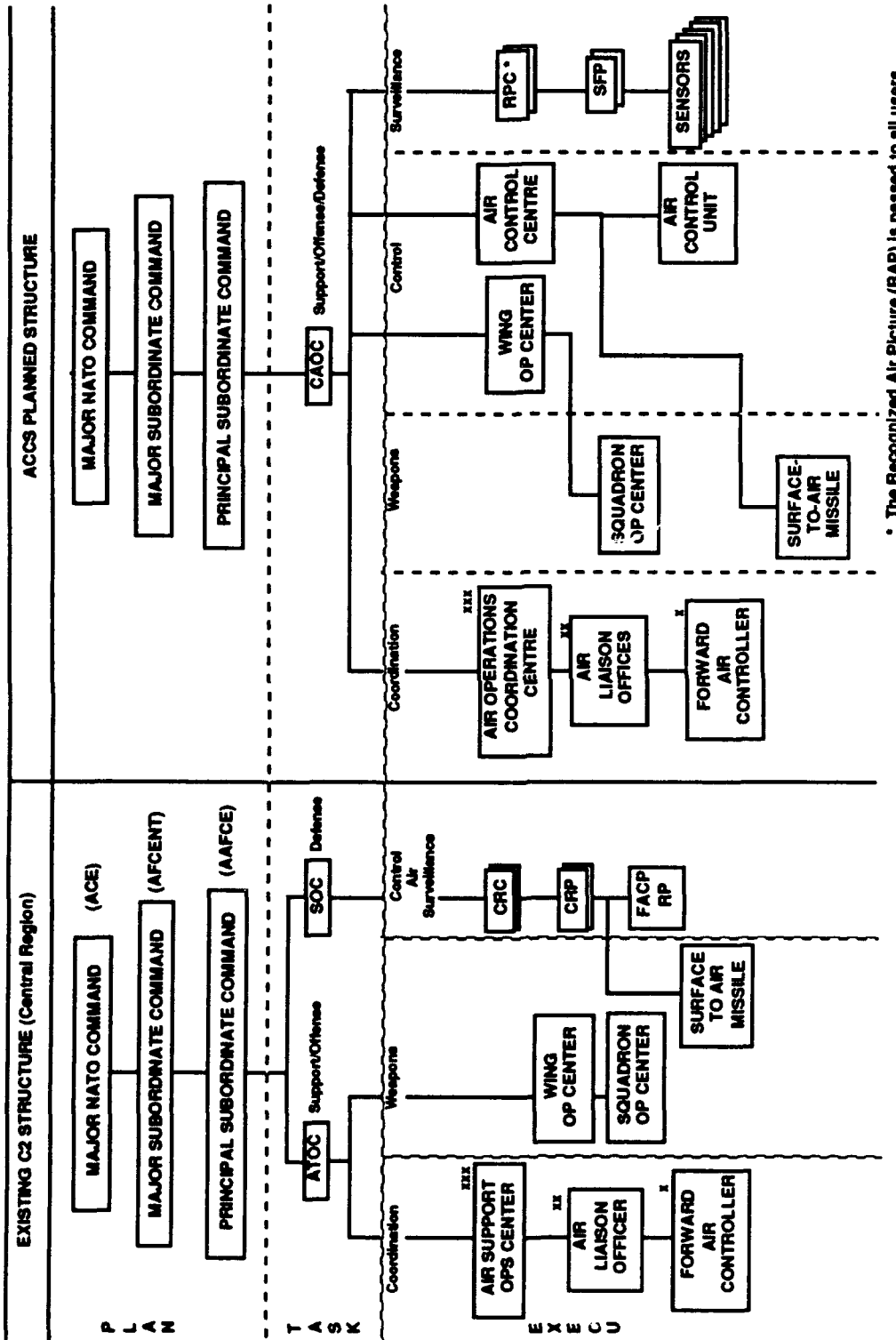

Figure 2. Existing and Planned NATO Air C2 Systems

UNCLASSIFIED

ID and track number, and upon the resolution of conflicting data, the RPC generates the RAP and distributes it to all the users as a utility. ACCS requires that the RAP be updated to all users every 5 seconds.

NATO intends that the ACCS will evolve from the existing NATO Air Defence Ground Environment (NADGE) over a period of years. To develop an affordable ACCS transition plan, NATO formed the Special Working Group (Transition) [SWG(T)] to prepare an ACCS Phase 1 Transition Programme covering the period 1991-1996. The SWG(T) then prepared a plan which determined which ACCS entities from the original ACCS Master Plan would be completed first, and where and when they would be implemented. The Phase 1 Transition Programme, which includes NATO and nationally funded ACCS elements, was intended to be coherent throughout NATO Europe. Further, the Transition Programme was to be operationally acceptable, technically sound, and within established budget constraints.

NATO-funded Integral ACCS (IA) projects were selected by the SWG(T) to satisfy the military needs and priorities for Phase 1. The NATO funding for the 6-year Phase 1 transition provided 70 MIAU² per year (420 MIAU total) from SACEUR and an additional reserve amount of approximately 180 MIAU (total) to ensure that the 420 MIAU would actually be spent during the 6-year period. This level of over-planning was to compensate either for the non-realization of some projects in the planning year, or to fund additional projects in the event funding above the planning figure of 70 MIAU per slice became available. In addition to the NATO infrastructure funds, the nations planned collectively to expend approximately 900 MIAU for IA projects in 1991-1996.

The Phase 1 Transition Programme, based on the ACCS design concept detailed in the ACCS Master Plan, concentrated on the development and implementation as soon as possible of the ACC, ACU, SFP, RPC, CAOC, AOCC, WOC, and SQOC entities. At the same time, older radars would continue to be replaced, bunkers for new entities would be built, and minimal improvements, such as the Ship-Shore-Ship Buffer (SSSB, a precursor to the MASSTIC) would be made to existing systems. Most of the Phase 1 effort was planned for the high priority Central and Southern Regions. Table 4 shows the locations of major ACCS entities planned for the Central Region and 5ATAF during the period 1991-1996. The approximate dates for implementation are shown for each entity. These are the ACCS entities that must be supported by communications as they are implemented.

² Million Infrastructure Accounting Units. One IAU is equal to approximately four U.S. dollars.

UNCLASSIFIED

Table 4. ACCS Entities to be Implemented in the CR and 5ATAF During Phase I Transition (1991-1996)

Area	Location	ACCS Entity	Implementation
Central Region 2 ATAF	Brock Zetel	ACC/RPC/SFP	1993-1995
	Breckendorf	ACC/RPC/SFP	1995-1997+
	Nieuw Milligen (NL)	ACC/RPC/SFP	1992-1995
	Nieuw Milligen (NL)	ATCRU	1991-1993
	Nieuw Milligen (NL)	SSSB	1992
	Kalkar	CAOC	1993-1996
	Uedem	ACC/RPC/SFP	1992-1995
	Glons (BE)	ACC/RPC/SFP	1993-1995
	Eendtebrueck	ACC/RPC/SFP	1994-1996
	Semmerzake	ATCRU	1992-1993
	Semmerzake	SFP	1995
	Auenhausen	ACC/SFP	1996-1997+
Central Region 4 ATAF	Sembach	CAOC	1992-1995
	Messtetten	CAOC	1992-1995
Italy 5 ATAF	Monte Venda	CAOCC/RPC/AOCC	1994-1997+
	Poggio Renatico	ACC/RPC/SAM CELL	1992-1995
	Poggio Ballone	ACC/RPC/SAM CELL	1993-1996
	(Various)	1 ACU/SFP (MOBILE)	1992-1996

B. THE ACCS GENERIC COMMUNICATIONS ARCHITECTURE

The ACCS concept requires a high level of integration of all ACCS entities to achieve maximum system efficiency. The integration is achieved by extensive automation throughout ACCS, resulting in increased information exchange between entities. To function effectively and meet response time requirements, such an automated ACCS requires high speed, efficient information transfer capability. This information flow consists of near-real-time data as well as voice and other data communications. The data information transfer is predominantly digital (i.e., tracks, and data file transfers). The data traffic is the most important driver in meeting ACCS communications response time requirements, such as the 5-second maximum update time for the RAP, and is categorized according to function. The ACCS functions of force management and air space

UNCLASSIFIED

management use primarily variable length, formatted text-type digital messages (referred to as character-oriented data). The automated data exchange between ACCS entity databases is based on event-driven updates, which are mainly bit-oriented file transfers. This type of data is not necessarily time-critical.

The ACCS functions of air mission control, air traffic control, and surveillance use primarily bit-oriented information, and are very time-critical. All plot data from a radar must be updated and delivered to the SFP within the radar's rotation cycle (nominally 10 seconds or less). Track data from the SFP and any other track source must be delivered to the RPC in real time so that the RAP can be updated, generated, and delivered every 5 seconds. The communications system must ensure that a RAP, which may consist of up to one thousand tracks from each RPC, can be transmitted and delivered every 5 seconds. Ideally, the RAP message should be sent only once to reach all users -- i.e., a single message that goes to multiple users rather than multiple messages that each go to a single user.

The ACCS communications system design envisions packet-switched data and digital circuit-switched voice common-user systems which interconnect all ACCS entities at Principal Subordinate Command (PSC) level and below. The network is interconnected by cross-border links for inter-regional communications, and uses gateways to enable users to access ground-air radio services and establish connectivity with maritime forces, army units, and external agencies (e.g., meteorological, air traffic control, and national authorities). Figure 3 illustrates the ACCS communications architecture of interconnected packet and circuit-switched networks.

The ACCS communications network design would replace the current maze of dedicated point-to-point voice, teletype circuits, and Link 1 point-to-point data circuits used throughout ACE for air command and control. The network is planned to consist of:

- A common-user, packet-switched, data system which replaces Link 1 and provides all required digital data transfer requirements including RAP distribution
- A common-user, circuit-switched, digital (64 kbps) voice system
- A number of ground-air-ground radio nodes distributed throughout the region and connected to the common-user communications system, providing all required voice and data interchange from ground ACCS sites with aircraft

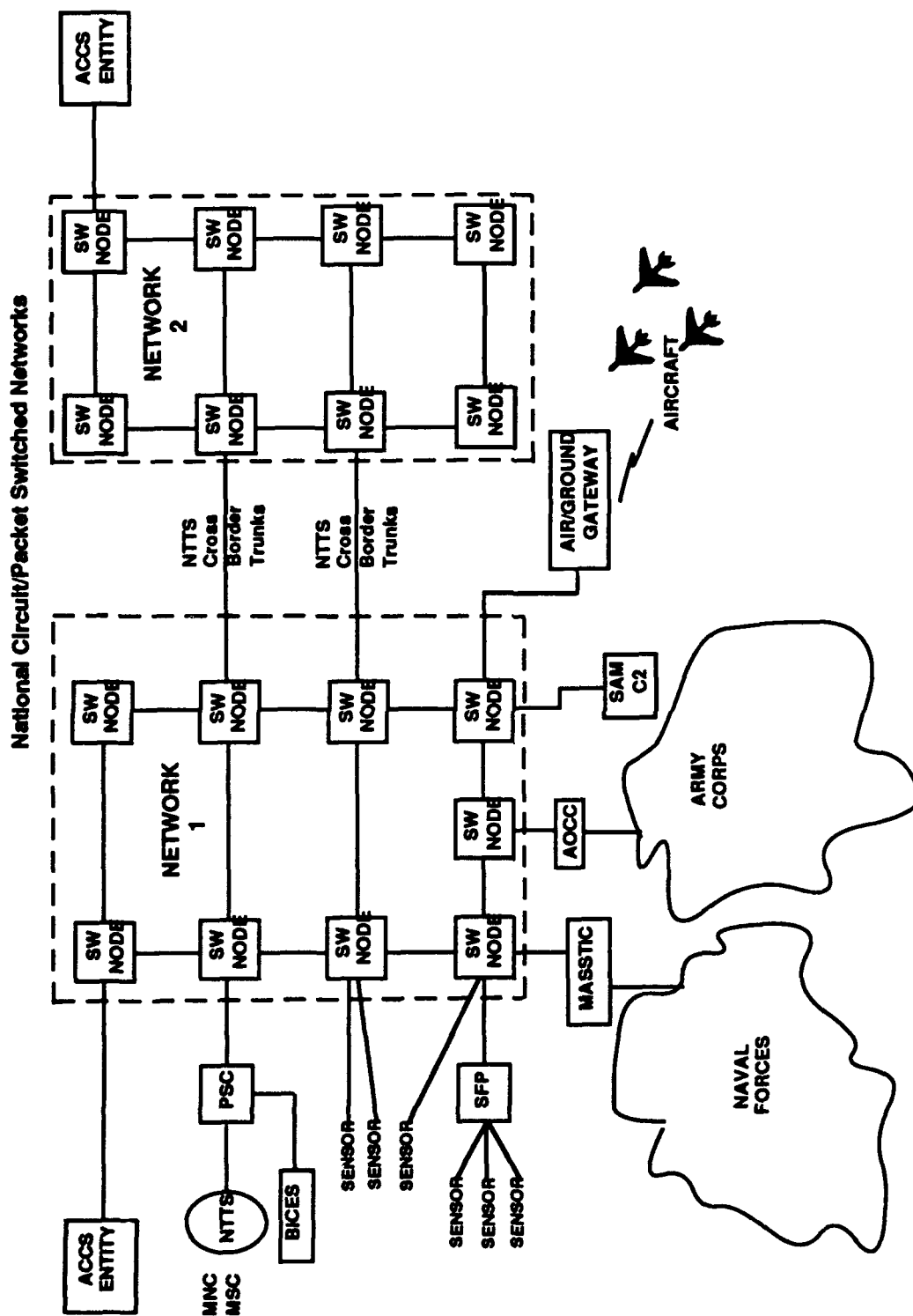

Figure 3. ACCS Communications Architecture

UNCLASSIFIED

- A communications processor located within each ACCS entity to interface the entity to the ACCS communications and the associated ACCS access trunks needed to connect to the common user network.

The communications system infrastructure which provides the transmission capability for ACCS communications consists of:

- A physical transmission plant (e.g., cables, radio relay) that provides the means to transport the communications signals between system nodes. This plant will be derived from NATO/national military communication systems.
- The packet data switches and circuit switches located at each node that respond to signaling information that directs data messages to their destination and connects voice users.

The technical data needed for voice and data information include:

- A standard set of data messages encapsulated into standard packets with standardized routing information, thereby enabling the computer to understand the data message and to set the switches to route these data messages correctly.
- A set of transmission standards that ensures interoperability between systems, and ensures that the data messages are properly entered into and transported through the system.
- A multiaddress protocol so that data messages do not have to be transmitted more than once.
- Sufficiently fast transit and switching times so that the critical 5-second RAP update requirement is achieved and maintained.
- Common telephone signaling information that enables the circuit switches to interconnect the called and calling parties.
- A common voice encoding standard so that voice circuits can be interconnected.

In the Central Region ACCS entities are located in three separate nations. Each nation has its own national military network. The interconnection of these networks, in order to create a region-wide transmission capability, requires military-owned links across the national borders. These interconnecting links, called Cross-Border Connections (CBC), are provided by NATO for NATO transmission systems such as the NATO Terrestrial Transmission System (NTTS). Nations may also establish CBCs between each other by means of bilateral national agreements.

ACCS communications, as detailed herein and in Volume IV, Generic and Regional Supplements to the ACCS Master Plan, will enable voice and data information to be

UNCLASSIFIED

exchanged among the PSCs and all ACCS entities below the PSC, with interfaces to navy, army, and other related command and control assets. The ACCS data system must, at a minimum, be in place and available when the transition from NATO Air Defense Ground Environment (NADGE) to ACCS commences. Voice communications are available from a variety of means.

ACCS will evolve its communications system from each nation's and NATO's military digitally switched networks. Commercial Postal, Telegraph and Telephone (PTT) networks will be used as necessary for backup. The NATO Terrestrial Transmission System (NTTS) may be used to provide ACCS cross-border connections between area systems. The user site communications facility (communications processors, internal voice distribution systems) and network access links that terminate and distribute voice and data information within each entity are procured as part of the entity. The system must interface with Link 1, which will continue to be used for the existing NADGE sites.

Upon completion of the transition, the ACCS communications system will replace the current mix of NATO and national dedicated voice and data circuits. The ACCS common-user, packet-switched data network will absorb Link 1 and most of the present data links used to pass air track data, and will use bit-oriented messages for sensor, RAP, and air operations data. Character-oriented messages will be used over the packet-switched network for text data transfer among the various ACCS entities, replacing the current point-to-point teletype circuits.

ACCS message and transmission standards are essential to begin the transition to the ACCS communications system. Without these standards the ACCS computers and national networks will neither understand nor be able to process ACCS data. The bit-oriented message standards are being codified by the Allied Data Systems Interoperability Agency (ADSIA) using, as a base, the J-Series message catalogue developed for Link 16 in STANAG 5516. The character-oriented message standards will also be developed by ADSIA. Technical data transmission standards needed to enable the various national networks to receive and transmit ACCS data messages must be either selected or developed by NATO. In particular, a multiaddress or connectionless protocol needs to be agreed upon. This standardization effort, normally accomplished by the Tri-Service Group on Communications-Electronics Equipment (TSGCEE), has not yet begun. The data link transition strategy detailed in Volume IV, Overall ACCS Design, Generic Portion, is summarized in Table 5.

UNCLASSIFIED

Table 5. Data Link Transition Strategy

	Baseline	Transition	Long-Term
ACCS Ground Environment Data Links	LINK1 LINK 3 LINK 6 LINK 7 MBDL ATDL-1 LINK 11B (Note 3)	LISA (Note 1) (also supporting mission management, control, status reports, C2RM, and sensors) ATDL-1 (Note 2) LINK 11B	LISA (single multi-functional message catalogue)
ACCS Ground-Air-Ground Data Links	LINK 4 (interim use only) JMS (NAEW) LINK 16 (initial deployment)	JMS LINK 16 (expanded use)	LINK 16
ACCS Maritime Data Links	LINK 10 (Note 4) (interim use only) LINK 11 LINK 14	IMPROVED LINK 11 LINK 14 (for non-LINK 11 ships) LINK 16	LINK 11 Replacement (to be defined) LINK 16

- Notes:**
1. NATO has entitled this link, which uses the enhanced J-Series message catalogue, "Link in Support of ACCS (LISA)."
 2. ATDL-1 may be necessary for certain direct ACCS interfaces with SAM fire units where no organic SAM control element exists.
 3. NATO has designated TADIL-B as Link 11B.
 4. LINK 10, and certain other national specific data links currently in use, to be phased out.

The following ACCS communications actions are needed to accomplish the ACCS transition:

- Provide, as part of the installation package, the communications devices associated with each ACCS entity, such as user site communications facilities, bulk and end-to-end encryption and access links
- Ensure that circuit and packet switches and trunk and circuit groups for communications supporting entities are made available by nations hosting ACCS entities
- Provide interfaces to facilitate communications, both with other systems and between entities and old air defense sites
- Establish agreed upon standards.

UNCLASSIFIED

C. BASELINE FOR GROUND AREA COMMUNICATIONS

Ground area communications that are candidates for the support of ACCS in the Central Region and 5ATAF include the present and future national military communications systems of the individual countries, tactical systems in the Central Region (as "tails" only), commercial PTT systems in the individual countries (as backup only), and the present and future NATO-owned systems.

1. NATO-Owned Communications Systems

a. The NATO Integrated Communications System (NICS)

The NICS presently supports communications requirements for NATO users, primarily at PSC level and above, including air command and control elements at those levels. The NICS also provides switched voice, telegraph service, and point-to-point circuits to certain NADGE sites, and provides interoperability via gateways with the U.S. Defense Communications System (DCS). NICS capabilities are severely limited in terms of overall capacity, connectivity, speed of response, interoperability with other systems, and wartime survivability.

Major elements of the NICS include:

- Initial Voice Switched Network (IVSN). This network consists of 24 analog access switches, associated interswitch access trunks, and access circuits. The switches are located at principal NATO headquarters and user concentrations. The IVSN provides narrowband circuit-switched services.
- Telegraph Automatic Relay Equipment (TARE). The TARE is a NATO-owned store-and-forward message switching system, consisting of 18 switches together with inter-TARE trunks and access circuits.
- In addition to IVSN and TARE, NICS includes a narrowband secure voice network overlay to the IVSN, the NATO III SATCOM subsystem, terrestrial transmission systems, and the Systems Integration Project.

b. The NATO Terrestrial Transmission System (NTTS)

NATO-owned terrestrial transmission facilities consist of the ACE HIGH system, which stretches from Norway to Turkey, the Communications Improvement Program 67 (CIP-67), and Satellite Communications (SATCOM). These, together with commercial Postal, Telegraph and Telephone (PTT), provide the source of transmission capacity for IVSN and TARE. The aging, analog ACE HIGH system is planned to be replaced by the

UNCLASSIFIED

NATO Terrestrial Transmission System (NTTS). The NTTS will be digital and, where possible, will use the capacity available on national military systems. Generally, facilities for cross-border connections will be implemented by NATO, but national systems will also be used, if available. Thus, NTTS will have the capability to provide the cross-border links necessary for interconnection of the separate national systems of the CR host nations, as well as for interconnections with other regions. However, to meet ACCS requirements for wartime survivability, NTTS cross-border links will probably require further augmentation.

The planned NTTS network topology, showing cross-border connections (CBCs) between the countries, is presented in Figure 4. Although the planned national networks of each country are not shown in this figure, the dates those networks are expected to be available for NTTS use (and presumably for ACCS use) are indicated, as well as the dates the CBCs are expected to be installed. The probable terminus of each end of each CBC is indicated by an abbreviation of the town name or, in a few cases, "TBD" (to be determined).

2. National Military Communications Systems in the CR and 5ATAF

The Central Region (CR) is unique among the various NATO regions in that it incorporates multiple nations (Belgium, Germany, and the Netherlands). Each of these has its own national military and civilian communications systems. Overlaying these systems are NATO communication systems that thread through the region. The ACCS is designed to provide an integrated command and control system throughout the region irrespective of national boundaries. The communications system designed to support ACCS consequently must be an integrated, unified, single, region-wide communications system.

Each nation within the CR has its own well-developed Postal, Telegraph, and Telephone (PTT) public telecommunications with modern voice and data transmission systems. The National PTTs are interconnected through international gateways. Each national military establishment and NATO has well-developed, modern communication systems and all are planning improvements. As a result, the CR is rich in communications capabilities. However, with the exception of NATO networks, the military communications networks (other than the DCS) are not designed and operated to serve region-wide needs because of their predominantly national orientation.

The Southern Region of NATO differs greatly from the Central Region. Each ATAF covers a wholly national area (5ATAF in Italy). The area is not as industrialized and

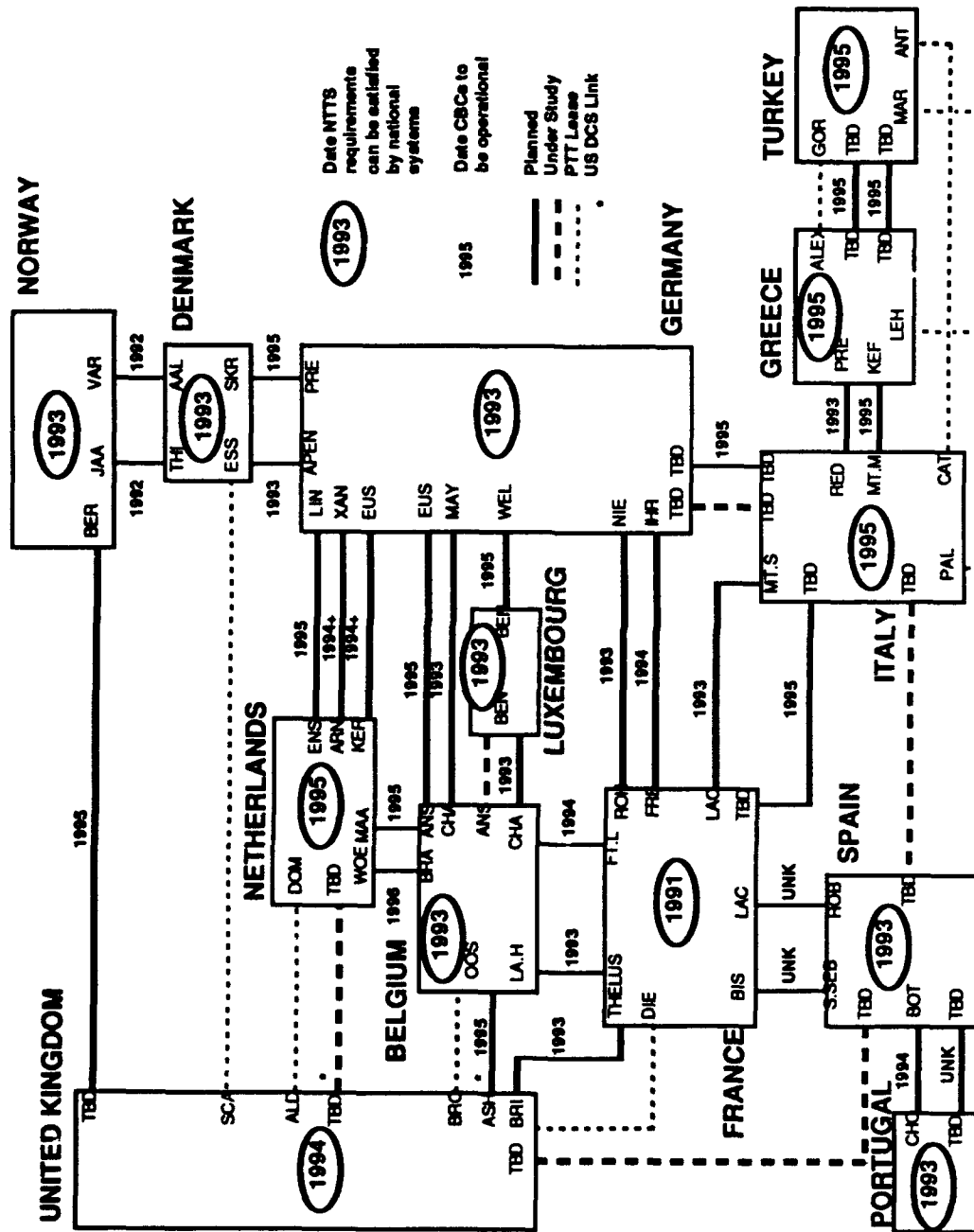

Figure 4. Planned NTTS Network Topology

UNCLASSIFIED

in general lacks the rich varied communication resources, both civilian and military, common to the Central Region. Lastly, the individual nations are separated by large bodies of water, making maritime force integration into ACCS much more important. Since the geography of the area, including Italy, is mainly mountainous with narrow coastal plains, the use of radio relay requires multi-hop paths with numerous repeaters. There is some use of troposcatter. Ground cable installations in the rugged terrain are expensive. Undersea cable is used extensively for links with other nations. The Italian PTT remains predominantly analog with limited digital transmission capability, particularly in southern Italy. Both the PTT and the military are commencing long-term conversions to digital transmission and switching, but owing to funding difficulties the work is proceeding slowly.

The ACCS communications system will derive its primary ground transmission capacity from national military communications systems. The national civilian systems (PTTs) are used for back-up capacity. Where needed, the system will make maximum use of the tactical military communications systems maintained by the national forces stationed in Germany, i.e., the United States, United Kingdom, and Canada. The principal national military communications networks, both current and planned, are discussed in the following paragraphs.

**a. The German Air Force Automated Communications System
(GAFACS)**

The GAFACS is the prime German component of the region-wide ground-ground network required to meet ACCS communications requirements in the near term. It is a unified command and control communications network designed for the support of the tactical operational mission of the German Air Force (GAF). The network is presently in the implementation phase and it is planned to achieve final operational capability in 1992. It is planned as an automatic, digital, circuit-switched network with digital switching and a combination of digital and analog trunk transmission facilities. It will provide voice, data, telegraph, and facsimile services to its users. The network interswitch signaling uses the ITT System 12 standard. Voice transmission is based on the 30-channel European CCITT digital transmission standard.

Radio relay interconnects all 36 switching nodes of the planned GAFACS network providing fully digital transmission trunks. The radio relay links will also be augmented by digital fiber-optic cable connections at certain locations. The radio relay trunk transmission

UNCLASSIFIED

system is laid out in a ladder-like structure, consisting of two main north-south routes in the western part of the FRG. Several lateral interconnections are provided between the two main routes, and additional extensions are provided to the east, connecting switching nodes and user access facilities. User sites not collocated with the trunk network nodes or other transmission facilities will be also connected, mainly by digital line-of-sight radio access links to the network. The initial design capacity of the radio relay trunks is 240 channels of 64 kbps each, provided by two multiplexed 8 Mbps groups.

b. The German Federal Armed Forces Integrated Services Digital Network (FAF ISDN)

In the longer term, Germany plans to integrate its digitalized Federal Armed Forces Strategic Communications System and the tactical communications systems (including GAFACS) of its individual military services. The new system, called the Federal Armed Forces Integrated Services Digital Network (FAF ISDN), will be based primarily on a fiber optic cable system to be built by the German PTT and employing military-owned switches. This core network will be further interlinked via gateways to the public Integrated Services Digital Network (ISDN) of the German PTT. The technology of the FAF ISDN will follow the European standards for ISDN as far as possible. The network will have a basic channel rate of 64 kbps with trunk switching at the 2 Mbps level, and will use CCITT Common Channel Signalling System No. 7. Thus, FAF ISDN will be interoperable with the other new national military systems in the Central Region, such as the Belgian BEMILCOM network and the NAFIN system of the Netherlands. Installation of over 100 digital trunk switches and around 200 digital local exchanges is already underway. By the year 1999, FAF ISDN will have integrated GAFACS into its network.

c. The Belgian Military Communications (BEMILCOM) Network

The BEMILCOM network is proposed as the Belgian component of the Central Region ground-ground area network supporting ACCS. It is presently being implemented to provide the Belgian armed forces, the Gendarmerie, and some governmental services with a national military telephone, telegraph, and data communications network. The system is fundamentally a static, circuit-switched digital meshed network for both voice and data transmissions comprising up to six time-division multiplex (TDM) transit switching centers. The network provides a large alternate routing capability with precedence and signaling facilities. The implementation of packet-switched data transmission capability for the network has also been considered, but no firm plans are

UNCLASSIFIED

available at this time. The complete network will consist of a large number (about 200) of fixed, EMP-protected sites throughout Belgium. Most of these sites will be interconnected by radio relay links and by analog or coaxial cable. Trunk transmission will be based on digital, 64 kbps channels, complying with CCIR and CCITT European standards. The CCITT #7 signalling system will be used. BEMILCOM is planned to be implemented in three phases: Phase I (northeast Belgium, including three transit switches, already completed); Phase II (southern Belgium along the French border, including two transit switches, by the end of 1992); and Phase III (central and western Belgium, including the last transit switch, by the end of 1993). BEMILCOM is not planned to be interconnected with the PTT.

d. The Netherlands Automatic Switched Communications Network (ASCON)

ASCON is the existing circuit-switched telephone network of the Royal Netherlands Air Force (RNLAf). The network is planned to be replaced during the mid-1990s, so its use for meeting longer-term ACCS requirements in the Netherlands is limited. The ASCON system consists of 10 TDM switching nodes interconnected by digital line of sight (LOS) links. The network is operated unmanned, except for a primary and a secondary system control center. User access is provided to the ASCON nodes by digital line-of-sight links (the same equipment as used for internodal links) or by military cable connections. ASCON uses North American standards, with a basic capacity of 4 digital 24-channel groups (56 kbps per channel, plus 8 kbps signaling), of which 2 groups are typically used on each internodal link. A further growth potential to eight digital groups per link is possible. The CCITT North American digital standard used by ASCON makes it difficult, but not impossible, to interface this network with GAFACS and BEMILCOM (which use European CCITT standards) for a fully effective regional network.

e. The Netherlands Armed Forces Integrated Network (NAFIN)

NAFIN is presently being planned to replace the existing ASCON and a number of other strategic communications systems presently operating in the Netherlands by 1996. Although NAFIN is a future system, it is firmly planned, and from the standpoint of the ACCS communications design for the Central Region, it can be considered a baseline system. NAFIN will be a digital, circuit-switched, ISDN-type network with a packet-switched overlay for data transmission. The network will fully comply with CCITT (Europe) I-series standards, using a 64 kbps channel structure. The network is planned to contain about 20 circuit switching nodes interconnected by 2 Mbps trunks using a mixture

UNCLASSIFIED

of military microwave links and the Netherlands PTT fiber optic cables. This will provide a good coverage of the country for connecting air force (including ACCS entities) as well as navy and army users. Two of the network nodes are planned to be located in the rear combat zone of the FRG for connectivity with the Netherlands army tactical networks.

f. Italian Tri-Service Network (ITSN)

The Italian Tri-Service Network is a gridded, analog transmission network which accommodates the defense telecommunication services of major national users (e.g., Italian General Staff, Army, Navy, Air Force). The ITSN is planned to be fully digitalized by the end of the 1990s, and will then be called the Digital Italian Tri-Service Network (DITSN). Army and Air Force segments of the current network will be incorporated into the whole, so that the final DITSN will be a defense-wide system, rather than the current mixture of defense and service segments. The present analog network comprises 31 nodal stations and 56 trunk-to-trunk stations with access capabilities. The DITSN will be based on digital off-the-shelf LOS microwave technology, and will have the same configuration as the analog network (plus some transportable, sheltered stations capable of performing as a nodal or a terminal station). The ultimate goal is a modern transmission network conforming to European CCITT transmission standards and capable of supporting an ISDN. The network will be digitalized in phases, beginning in the north, with new digital links scheduled for completion in 1991. After the new northern links are completed, the older analog links to the south will gradually be digitalized. This second phase of digitalization will include a north-south digital backbone during the period 1993-1995. Digitalization of the entire network is not expected to be completed before the year 2000.

3. The Defense Communications System (DCS)

The U.S. Defense Communications System (DCS) in Europe comprises transmission facilities, common-user switched voice and data networks, a secure voice system, and other capabilities. The DCS transmission facilities in Europe include military-owned analog and digital line-of-sight microwave and tropospheric scatter radio systems, communications satellites and associated satellite ground terminals, and leased commercial (PTT) circuits. Some DCS transmission capacity is derived from transmission exchanges with NATO and host nations. A substantial portion of European DCS transmission facilities has been upgraded to digital LOS operations to form the Digital European Backbone (DEB). Further upgrades and expansion projects are planned. Portions of the DEB/DCS have already been offered to NATO to provide transmission for the NTTS on a

UNCLASSIFIED

quid pro quo basis. With the expected drawdown of U.S. forces in Europe, it is possible that some portions of the DEB/DCS could be made available to support ACCS transmission requirements.

4. Comparison of National Military Communications Networks

Table 6 compares some of the basic transmission (multiplexing) and signaling standards of the national military communications networks discussed in this section, and shows the approximate dates that each system reaches Initial Operational Capability (IOC) and Final Operational Capability (FOC). The newer systems (FAF ISDN, BEMILCOM, NAFIN, and DITSN) will be interoperable at these levels, while the older systems (GAFACS, ASCON, and the DCS) will not be interoperable with the newer ones without the use of gateways. The GAFACS signaling system (ITT System 12) differs from all the other systems in the region.

Table 6. Comparison of National Military Communications Networks

Network	Country	Channel Rate	Level 1* Trunk Rate	Channels Per Trunk	Signaling Standard	IOC Date	FOC Date
BEMILCOM	Belgium	64 kbps	2.048 Mbps	30 Ch	CCITT #7	1989	1993
GAFACS	Germany	64 kbps	2.048 Mbps	30 Ch	ITT System 12	Opn'l	1992
FAF ISDN	Germany	64 kbps	2.048 Mbps	30 Ch	CCITT #7	1993	1999
DITSN	Italy	64 kbps	2.048 Mbps	30 Ch	CCITT #7	1991	2000
ASCON	Netherlands	56 kbps	1.544 Mbps	24 Ch	Channel Associated E&M	Operational	
NAFIN	Netherlands	64 kbps	2.048 Mbps	30 Ch	CCITT #7	Unk	1996
DEB/DCS	NATO-Wide	56 kbps	1.544 Mbps	24 Ch	Channel Associated E&M	Operational	

* Level 1 is the lowest aggregate of digital channels for bulk transmission.

D. COMMUNICATIONS AVAILABILITY TO SUPPORT ACCS

1. Determining Communications Availability

The ACCS Master Plan, Volume IV, Generic Design, states that ACCS will make maximum use of existing and planned national military and NATO digital transmission systems wherever possible. The Central Region Design Supplement recommends that

UNCLASSIFIED

ACCS communications use a common-user, meshed, digital "core" network formed by interconnecting transmission trunks derived from the national military digital communications systems of the region's three nations. The 5ATAF design supplement states that ACCS communications will use transmission trunks derived from the Italian military network and NATO digital circuits. The supplement does not, however, address how the circuit and packet switches necessary to create an ACCS communication system would be provided from either source.

The core of networks is interconnected by NATO-owned cross-border connections (CBC). It is further augmented by interconnections with military communications operated by the four nations and by British, Canadian, and U.S. forces in the region. (In particular, their tactical networks are needed to reach air bases and other entities not served by the "core" network.) Based upon NATO funding eligibility rules, the majority of ACCS communications transmission requirements must be satisfied by the national military systems, with limited NATO assistance beyond providing CBCs.

To determine whether all the necessary parts of the ACCS communications system will be available when the ACCS entities are implemented, it is necessary to analyze the Phase 1 Transition Programme and compare it to the expected availability of transmission plants, circuit and packet switches, data exchange standards, and communications technical standards and interfaces. All these elements must be present. Further, all these elements must be managed so that each is implemented in time to support the others, and so that all are ready to support the ACCS entity. An analysis of the availability of these elements to support ACCS follows.

2. Transmission Plant Availability

The geographical location of the ACCS entities in the Central Region countries and 5ATAF, together with the national digital military networks that would support them, are shown in Figures 5 through 8. The dates shown for each ACCS entity are the implementation periods shown in the ACCS Master Plan, Volume V, Phase I Transition. Also shown are the reported completion dates for the communications networks.

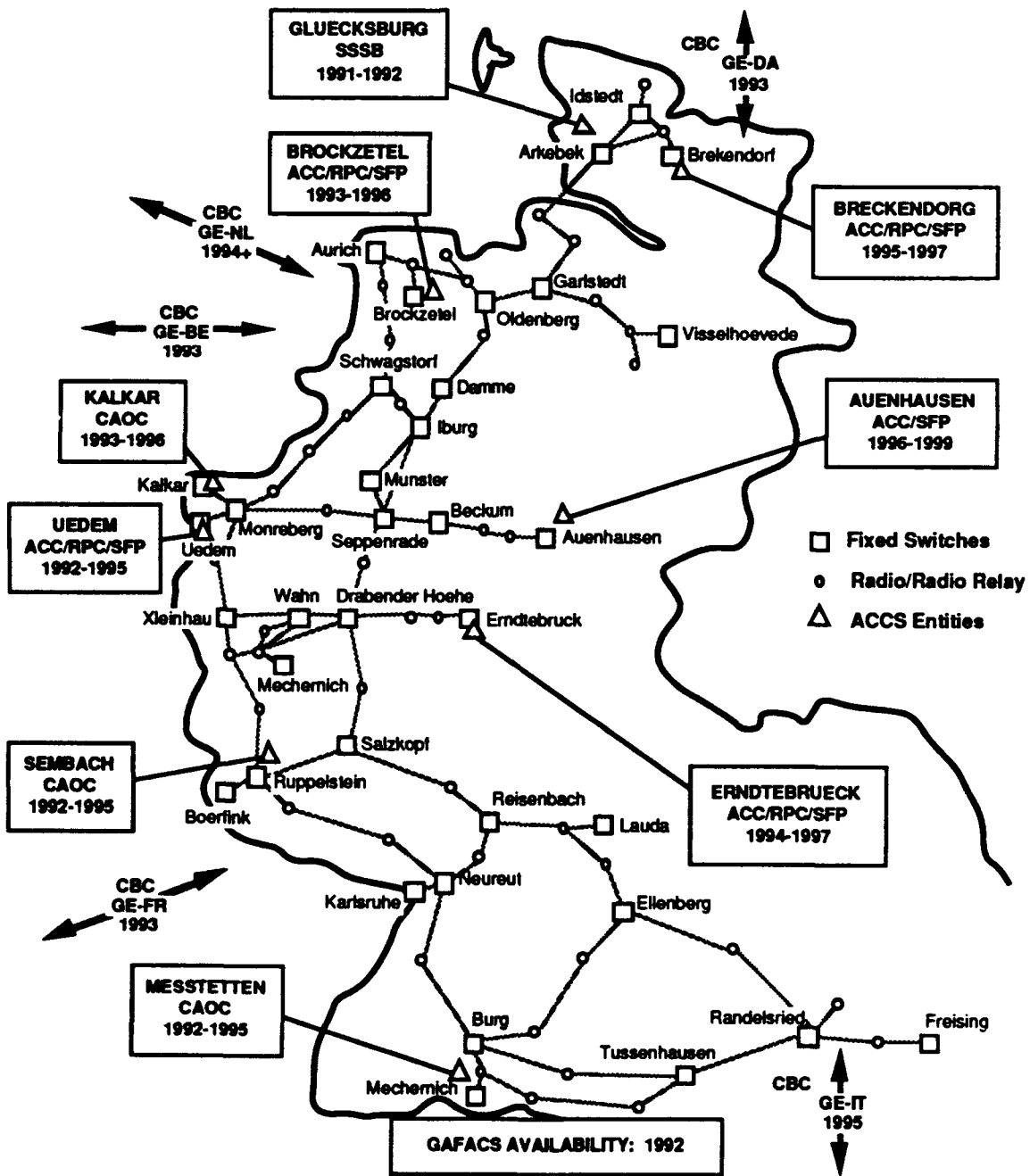

Figure 5. Digital Transmission Availability for ACCS In Germany

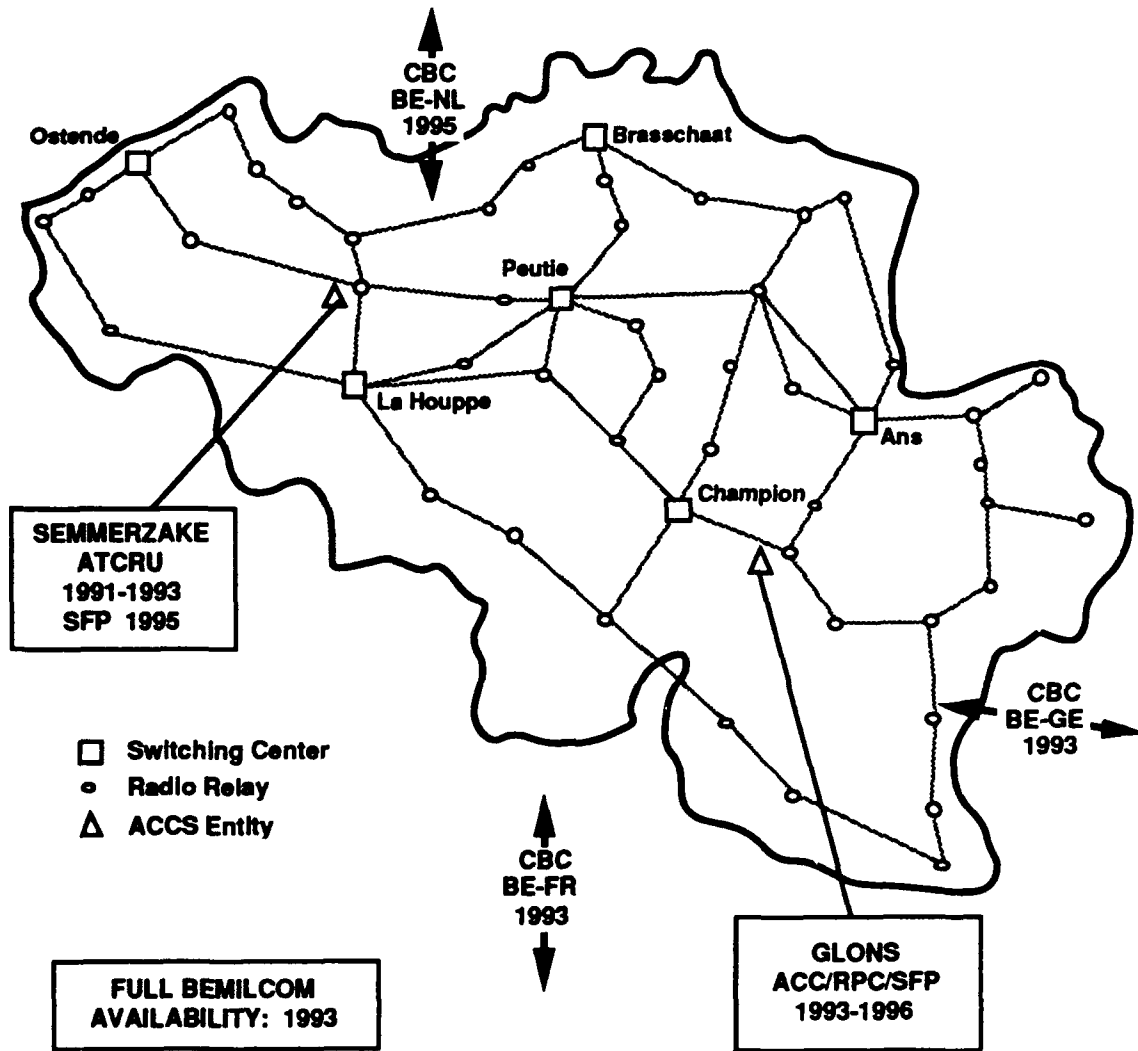

Figure 6. Digital Transmission Availability for ACCS in Belgium

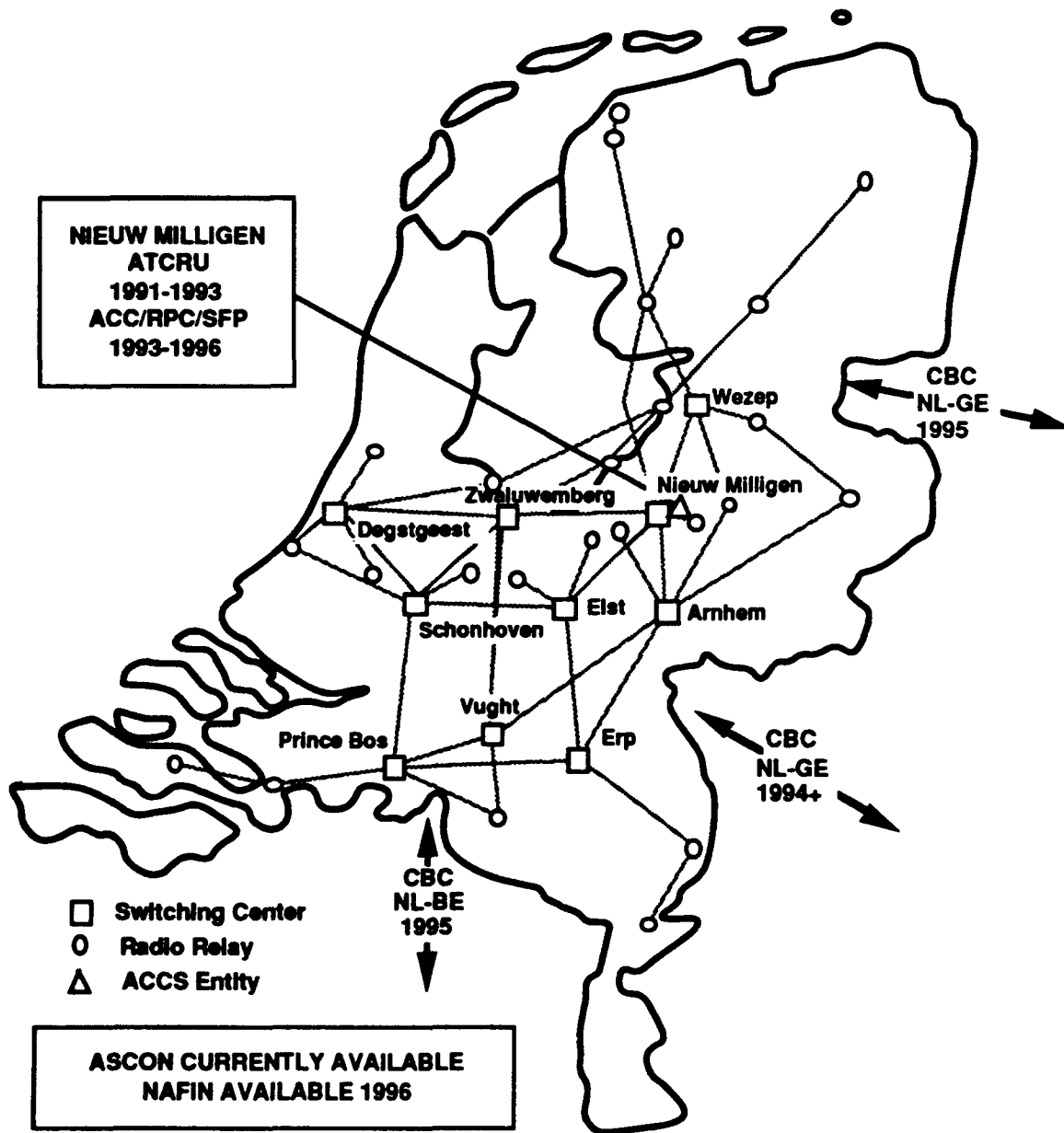

Figure 7. Digital Transmission Availability for ACCS In the Netherlands

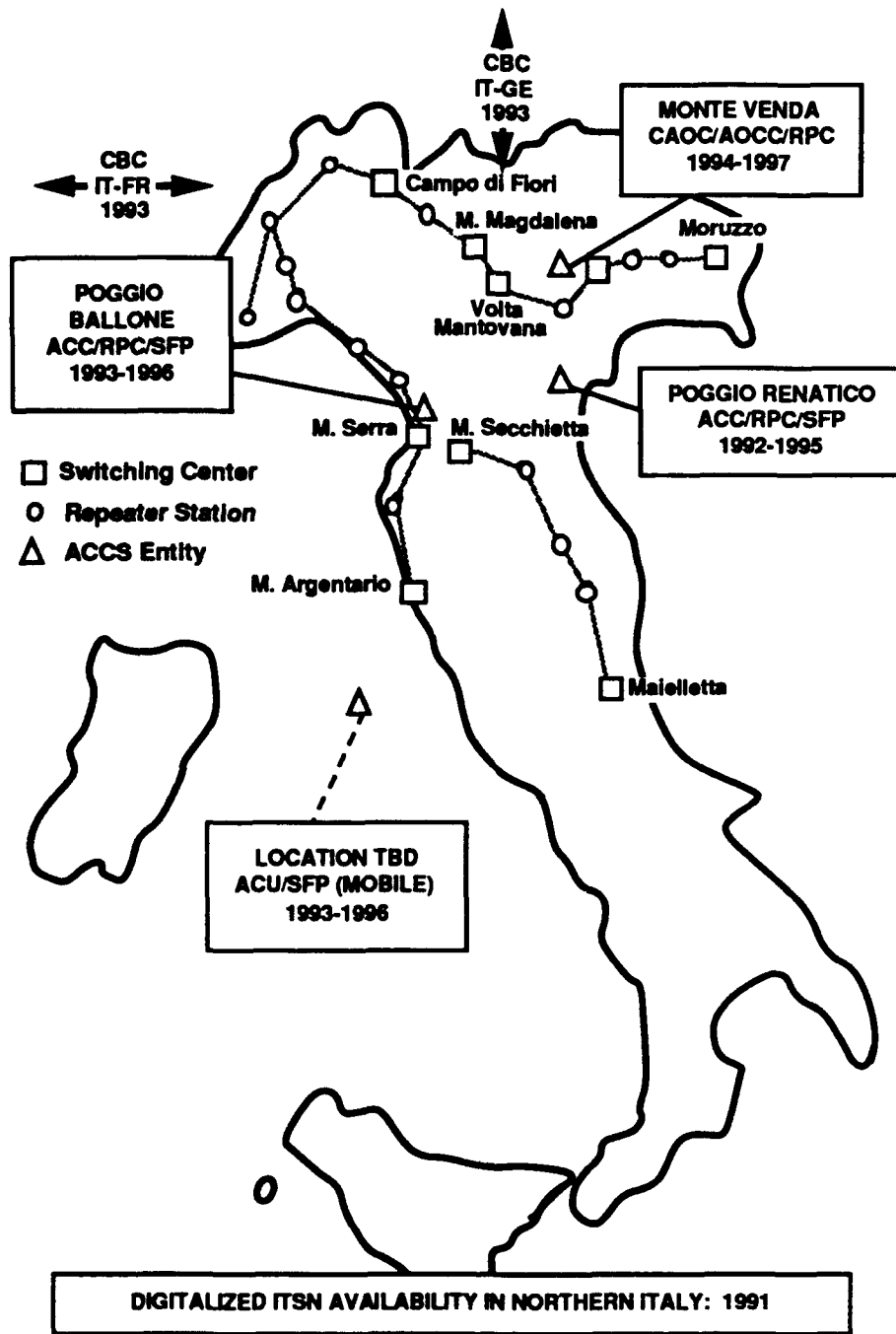

Figure 8. Digital Transmission Availability for ACCS in 5ATAF

UNCLASSIFIED

In Germany, the GAFACS reportedly will be complete and in place by 1992. Hence digital transmission trunks and circuits should be available before most ACCS entities need them. ACCS entities are immediately adjacent to GAFACS switch nodes, so they could be connected to the network easily. When the FAF ISDN is implemented, it will eventually incorporate the GAFACS, so the same entities can still be supported. All necessary CBCs from Germany (to Denmark, the Netherlands, Belgium, and France) are also scheduled to be in place by the implementation dates of Phase I ACCS entities. Figure 5 illustrates the proximity of ACCS entities to the GAFACS nodal switches, and also shows the planned CBC dates.

In Belgium, a similar situation prevails. The Phase I Transition entities are located close to network access nodes of BEMILCOM, and the network will be implemented prior to the ACCS entities. CBCs to Germany and France are also scheduled to be installed before the ACCS entities. This situation is illustrated in Figure 6.

The Netherlands shows a somewhat different situation. The ASCON is currently in place and has digital transmission capability, but since it uses different data standards (CCITT North American) than either Belgium or Germany (CCITT European), an interface must be used to interconnect the transmission plants. Such interfaces already exist (they are currently in use in the DCS in Europe), so they could be acquired. The NAFIN, which is scheduled to replace ASCON in 1996, eliminates this problem. Since NAFIN does replace ASCON, it is presumed that access nodes will be in many of the same locations. Therefore, digital transmission trunks should be available for the ACCS entities at Nieuw Milligen when they are implemented. The proximity of Nieuw Milligen to an ASCON nodal switch is illustrated in Figure 7, which also shows the CBC availability dates.

Within Italy, the digitalization of the ITSN will occur first in the north. This is the area that Phase I ACCS entities are planned for, and the digitalization is planned to be completed in 1992. The AFSOUTH assessment, however, is that the digitalization of the ITSN is only partially planned, and only for the northern sector. Assuming no further major technical or financial constraints occur, the system should be digitalized in time to support Phase I ACCS entities in the north, but digital transmission availability for later ACCS entities in the south is not as probable. CBCs to France and Germany are scheduled to be implemented in time to support the ACCS entities. The situation in Italy is illustrated in Figure 8. Although Poggio Renatico appears to be somewhat isolated from the new digital networks, its position in the relatively industrialized northern part of Italy and in proximity to the old analog portion of the ITSN makes it likely that it can be connected to the digital system, but this information is not yet known to the IDA study team.

UNCLASSIFIED

Table 6 above compares the transmission and signaling of the national military networks and the DCS. As this table shows, the newer networks will use CCITT Europe transmission standards (2.048 Mbps Level 1 trunks containing 30 circuits of 64 kbps each) and CCITT #7 signaling standards. For interoperability of circuit switched networks, gateways will be necessary to interface GAFACS, ASCON, and the DCS to the newer networks. The lack of signaling interoperability would not affect the ACCS packet-switched network. This network would use semi-permanent digital trunks to connect the packet switches, which would provide their own signaling.

In summary, the ACCS entity transmission circuit needs can be provided by the national military communications systems, despite some interface problems. Information on the bandwidths that could be made available to ACCS is not known, but most of the ACCS circuits will simply replace the circuits already justified, approved, and being carried by existing national transmission systems. However, the ACCS requirement is now for mostly common-user digital circuits, rather than dedicated analog circuits. Table 7 summarizes the ACCS entity and national digital transmission plant availability. This table shows that, with a few exceptions, the required transmission capability is planned to be available. The exception is Nieuw Milligen (NL). This entity will require an interface unit for interoperability until such time as NAFIN is completed.

3. Digital Voice Circuit Switch Availability

All of the national networks have a circuit switch capability and a digital voice capability. Consequently, the establishment of voice circuits is entirely possible. The capability will certainly be available. The major problem here is that the signaling data used by each system is not standardized. As a result, interfaces will be required so that one system can signal a call to another system.

4. ACCS Packet Data Switch Availability

The packet data switches are essential elements of the ACCS data communications system. These switches provide the needed switching and routing capability that enables the packet data messages to be directed to their destinations rapidly and reliably. Analysis of the Phase 1 Transition Programme reveals that no packet data switches are being procured. Indeed, there are no funds budgeted for any ACCS communications items, including packet data switch procurement and installation. Additionally, there is no information concerning who will provide this switching capability. This is a critical shortcoming, since this capability must exist for Link 1 replacement.

UNCLASSIFIED

Table 7. Transmission Trunk Availability

Location	ACCS Entity	Implementation Period	Trunk Available	CBC Available	Minimum* Slack Time
GERMANY					
Uedem	ACC/RPC/SFF	1992-1995	1993	1994 (NL)	1
Sembach	CAOC	1992-1995	1993	1993 (FR,BE)	2
Messtetten	CAOC	1992-1995	1993	1993 (FR,BE)	2
Brockzetel	ACC/RPC/SFP	1993-1995	1993	1993 (DK)	2
Kalkar	CAOC	1993-1996	1993	1993 (NL)	3
Erndtebrueck	ACC/RPC/SFP	1994-1996	1994	N/A	2
Breckendorf	ACC/RPC/SFP	1995-1997+	1993	1993 (DK)	4
Auenhausen	ACC/SFP	1996-1997+	1993	N/A	4
BELGIUM					
Semmerzake	ATCRU	1992-1993	1993	N/A	0
Glons	ACC/RPC/SFP	1993-1995	1993	1993 (GE)	2
Semmerzake	SFP	1995	1993	N/A	2
NETHERLANDS					
Nieuw Milligen	ATCRU	1991-1993	1995	1994 (GE)	-2 **
Nieuw Milligen	ACC/RPC/SFP	1992-1995	1995	1993 (BE)	0
ITALY					
Poggio Renatico	ACC/RPC/SFP	1992-1995	1991	1995 (GE)	0
Undetermined	ACU/SFP (Mobile)	1992-1996	Unknown	N/A	Unknown
Poggio Ballone	ACC/RPC/SFP	1993-1996	1991	1995 (FR)	1
Monte Venda	CAOC/RPC/AOCC	1994-1997+	1991	1995 (GE)	2

* Minimum slack time is the lesser of the number of years between the availability of trunk or CBC and the end of the ACCS entity implementation period.

** Communications for Nieuw Milligen can be provided earlier by the existing ASCON system, but a gateway will be required to provide interoperability with the other national systems.

The importance of the ACCS packet-switched data network cannot be overemphasized. ACCS is an aviation system which requires much shorter response times to cope with modern air warfare. ACCS offers a quantum increase in knowledge of the air picture that will allow faster aircraft turn-around times and better control. Air track data is the most important data that the ACCS works with and responds to. With new data processing techniques, this data can be refreshed every 5 seconds, twice as quickly as with older systems that were limited to the scan rates of long-range radars. The 5-second air track update rate is the primary driver for a common-user packet-switched network dedicated to ACCS. While air track data are currently transmitted over dedicated point-to-point circuits (Link 1) in NATO, such an arrangement is not practical for handling the volume of such data in ACCS. A common-user system has great advantages for data link systems. It can distribute data to users faster and requires far less circuitry than point-to-point systems. However, the issue of providing a multiaddress capability for a common-user packet system has not been addressed. Without such a protocol, the RAP must be sent individually to each user, which will greatly increase data loads.

UNCLASSIFIED

NACMA considers the provision of communications between ACCS entities to be a national responsibility. Presumably, this includes switching, as well as transmission, capability. The statement of work, which includes the development of a specification for a notional ACCS communications system including ground-ground and ground-air-ground systems, does not address packet data switch requirements. If packet data switches are not procured for ACCS, then data switch standards would have to be provided if the packet data systems of the various nations concerned were to interoperate.

It does not appear that the individual nations have agreed upon a standard packet switch for their respective national military packet-switched systems. While Belgium and the Netherlands have firm plans for packet-switched data systems, they will not necessarily be compatible, as there is no current requirement that they should be. Further, German military plans for a packet-switched system are not clear, and when such a system will be implemented is not known. As a result, the feasibility of using the national military packet switches for ACCS data communications is not known. Operationally, such use of national switches for NATO data (particularly air track data) may be unacceptable owing to the greatly increased throughput requirements to meet the near-real-time air track data transfer requirements. The use of a commercial (PTT) packet system was not considered, since PTT systems are to be used only as a backup for ACCS communications.

The great bulk of ACCS data can probably be sent via national packet data networks (if and when they exist and to the degree that they are interoperable) because most of this data is not subject to severe time constraints. Information such as status, allocations, mission results, alert stages, and file transfers are in this category. However, there is a unique class of data peculiar to ACCS that simply requires a dedicated network to meet its response time requirements. This is the air track data obtained from the sensor network and which, when properly fused, correlated with other air track sources, and identified, constitutes the RAP that is the core of ACCS. However, it appears that ACCS packet data communications are being left as a national responsibility with no plans for NATO or NACMA action in this area. Also, the national military packet-switched systems might not be interoperable, although the IDA study team was not able to obtain any information on this. In any case, there appear to be no plans to satisfy the most critical ACCS information transfer requirement, including the need for a multiaddress capability.

5. Data Exchange Standards

The development of data message standards in NATO is a responsibility of ADSIA. ADSIA Working Group 4 (WG-4) is tasked to develop and maintain the bit-oriented procedural standards for a ground-to-ground data link necessitated by ACCS, including message catalog, data element dictionary and standing operating procedures. WG-4 has in turn established a sub-group to concentrate on this data link, now called "Link in Support of ACCS (LISA)." The procedure is to use the ACCS System Specification contractor-developed Information Exchange Requirements (IER) as the basis for development of the ACCS message catalogue. These IERs provide the operational information that is encoded in the bit-oriented data messages. SHAPE, supported by a user involvement group, will use the IERs to establish the operational requirements, to be forwarded to the contractor by NACMA. The contractor will conduct analyses and make proposals to NACMA which, after approval, will be documented as system specifications, including requirements for data exchange within and between entities. The IERs between entities will be formally validated by SHAPE and sent to ADSIA for development into message standards. The ADSIA standards will then be required for the system and entity designs.

The contract for development of the IERs began in January 1991, so the final IERs will not be available until September 1992, the 20th month after start of contract. In the interim, ADSIA will use the IERs developed previously by the ACCS Team (precursor to the IMG/NACMA) to identify data elements for ACCS messages. These will be recommended with the final IERs. It therefore appears that there is a definite formal procedure to establish ACCS message standards, and that the process is working. However, it is a lengthy, cumbersome process, and it will require careful coordination to ensure that it is accomplished smoothly.

Within NATO, development of the required technical transmission standards is a responsibility of the Tri-Service Group on Communications-Electronics Equipment (TSGCEE). The TSGCEE developed the technical transmission standards for Link 16 documented in STANAG 4175. (STANAGs 5516 and 4175 together completely describe Link 16.) A similar set of standards would be required for any dedicated ACCS packet data system. Additionally, standards must be established for any NATO/national data communications system. Identification of these standards and the extent to which they support ACCS requirements has not been done. Formal tasking to the TSGCEE similar to the tasking for message standards has not been accomplished. The Secretary of the TSGCEE has indicated that these standards will be based upon a common-user packet-switched system. However, it does not appear that work has started on the development of these essential standards.

6. ACCS Management Issues

There are numerous NATO bodies involved in the planning, development, and integration of the communications support of ACCS. As a result, it is sometimes difficult to associate all the diverse parts of ACCS communications with the responsible activity. It is clear, however, that there does not seem to be an overall, coherent plan to achieve an ACCS communications system implementation strategy with measurable milestones. In view of the large number of personnel, both NATO and contractor, that are contributing to the establishment of ACCS communications, there is a need to focus all this activity on a coordinated and coherent objective to achieve communications that can support the planned ACCS implementation.

To illustrate the need for close coordination: NACMA contends that, in accordance with NATO infrastructure rules, communications between entities is a national responsibility. CBCs between entities appear to be a NATO responsibility. Message and transmission standards are a NATO responsibility. There are long-term initiatives by SHAPE to replace the NICS ultimately with a strategic level (PSC and above) multi-purpose, common-user, packet-switched data system that ACCS may or may not use, according to whatever requirement ACCS states. A partial list of those agencies concerned with ACCS information exchange is presented in Table 8.

Table 8. Agencies Responsible for ACCS Information Exchange

Organization	Responsibilities
NACMA	ACCS System Specification, including communications subsystem Information Exchange Requirements
NATO Committees ADSIWG-4 TSGCEE	Development of message standards Development of transmission standards
Military Agency for Standardization (MAS)	Standards approval
NACISA	NTTS NATO common-user data transfer capabilities NICS: TARE and IVSN Long-term NATO communications
SHAPE	Operational requirements Approval of Information Exchange Requirements Coordination of SHAPE Technical Centre actions Coordination with ongoing Army Tactical Command and Control Information System (ATCCIS) standards
NATO Nations	Installation and operation of national military communications systems

7. Transition Issues

The Phase I Transition Programme seeks to maintain present capabilities during the implementation period. This implies that much of the existing equipment and installations will need to be kept in operation well beyond the year 2000. This will create a constantly changing and mixed environment which by itself will cause interoperability problems. To maintain the older systems in operational condition will be difficult due to lack of spare parts and the unavailability of equivalent equipment. On the other hand, systems which have been fielded after the initial NADGE program are likely to operate well into Phase 3 (2003-2008) without major technical problems. The mixed ground environment which evolves after 1995 will pose a challenge to interoperability of command, control and management functions that must be considered as well as the entity implementations themselves. One way to alleviate some of these problems is to provide the remaining NADGE sites the capability to communicate with the ACCS entities via the new ACCS data link as early as possible.

Replacement of Link 1 with the ACCS data link would provide significant operational advantages:

- All external ground-ground communications would be conducted in accordance with the same protocol
- The ground communications system could be utilized more effectively
- Classified air picture and battle management data required at NADGE units to perform their air mission control tasks could be transmitted
- Exchange of data between differently classified link systems (Link 1 is unclassified) could be conducted.

E. CONCLUSIONS AND RECOMMENDATIONS

1. Conclusions

ACCS is a very communications-intensive acquisition. Communications is so much a part of the total system that it would be foolish to deploy a new ACCS entity unless the communications elements to support it are in place by the time the entity is expected to be operational.

ACCS demands more modern communications networks than are currently in place throughout the Central Region and 5ATAF. The transmission systems must be digital to support secure voice and high data rates. A packet switching system is necessary to handle and distribute the near-real-time air track data. The data switching network for air track

UNCLASSIFIED

data may have to be dedicated to ACCS since it is such an ACCS-unique requirement. The character-oriented general data traffic and the digital voice can, in all probability, be supported by national packet-data-switched and circuit-switched systems. Here, however, complete interoperability for data and voice signaling must be assured. Currently it is not assured. ACCS cannot be implemented until these transmission and switching networks are in place, and unless each of the networks is interoperable with like networks in adjacent regions.

There are no budgeting or planning data concerning the procurement of packet data switches for ACCS, and yet these switches are required to realize a viable data exchange system between ACCS entities. This indicates that there may be a lack of intent to ever implement the critically needed ACCS packet switched data system to replace Link 1 and provide the required information exchange to integrate ACCS entities. The absence of planning or budgeting data is also evident in the case of voice circuit switches.

For digital transmission systems, ACCS will primarily depend upon national digital military networks which are being or have been installed in the Central Region and 5ATAF. The NTTS (which also depends on these national networks) may possibly carry some of the ACCS circuits. Cross-border connectivity of these transmission systems is also required, whether it be provided by bilateral agreements between nations, or through the CBCs of the NTTS.

The national military transmission systems and NTTS CBCs are expected to be available in time to support the ACCS entities in the Phase I Transition Programme in the CR and 5ATAF, but interfaces (gateways) will be required between some of the older and some of the newer networks because of dissimilar transmission and signaling standards. Further, there is no guarantee that the NTTS CBCs can be used by ACCS below PSC level.

To ensure computer-computer understanding and provide effective transmission of ACCS messages on the data communications network requires a standardization of data *message* formats into catalogs, data element dictionaries, and standard operating procedures (protocols). This work is underway, but the process will be long and complex. Additionally, data *transmission* protocols must be delivered and implemented. At issue here is what standards will be used and whether new ones will be required. In particular, the issue of a multiaddress standard requires attention. The connectionless protocol of the X.25 standard is vague and will require much work to standardize.

UNCLASSIFIED

Because there are numerous NATO agencies and committees involved in the planning, procurement and integration of ACCS communications support, it is difficult to understand all facets of ACCS communications. In general, there is no one agency to monitor and direct these efforts to ensure that they result in clearly-defined ACCS communications deliverables, in accordance with definite milestones, to meet scheduled needs. There is an urgent need for a single coordinated ACCS communications implementation plan that directs the many activities concerned towards the goal of ACCS data communications support by showing what is to be done, by whom, and by when.

With the significant reduction of the threat and concurrent reduction in funding, a new ACCS concept with considerably fewer entities (many of which are mobile) is under development by a SHAPE team known as ORACLE. This new ACCS concept could dramatically change the communications requirements, but the principles that support this study will remain valid even if the post-CFE World should yield new findings.

2. Recommendations

Until budgeting plans, with implementation dates, are known for circuit and packet switched networks that can be used to support ACCS, *no* ACCS entities should be supported. The United States should maintain its stated position that the availability of communications (including required switching capabilities) is a prerequisite for supporting the acquisition of ACCS entities.

The preparation of the ACCS data message standards must be carefully coordinated to maintain interoperability between all parts of the communications system, and to ensure the availability of the data messages for ACCS entities when installed. Similarly, the preparation of multi-address data transmission standards must be started and carefully monitored. The TSGCEE should be tasked by NATO to begin work on these standards.

If not already doing so, NACMA should develop a coordinated, integrated communications implementation plan with milestones and ensure that everyone works toward the same goals and that the many ongoing efforts result in a communications system that can support ACCS.

Since post-CFE implications of ACCS and its communications were outside the scope of this study, further study would be required to determine communications available for ACCS under the ORACLE concept. This report could be used as a starting point for such an effort.

UNCLASSIFIED

(This page intentionally left blank)

UNCLASSIFIED

UNCLASSIFIED

Part 3
ANALYSES

UNCLASSIFIED

I. ACCS ORGANIZATION AND PLANNING

A. ACCS ORGANIZATIONAL STRUCTURE

ACCS was conceived as an integrated system comprising organizational structure, entities,¹ communications, and personnel. The ACCS design focused upon these areas. The ACCST determined that system concepts and design options would be based on air command and control functions. Functions are essentially constant and must be performed regardless of the requirements, character, or organization of the selected system. Essentially, functions describe what must be done and requirements define how well they must be performed.

The ACCS organizational concept was developed using a functional approach with sequential steps.² This functional approach produced a modular structure, enabling the resultant entities and elements to have a standard design and to achieve the required ACCS commonality. This approach also allows modification of the derived generic organizational structure, as needed, to satisfy specific regional needs and characteristics. The three sequential steps used for the development of the ACCS organizational structure consisted of a functional breakdown, creation of functional modules, and organization of entity types. These steps are shown in Figure 9, below, and summarized as follows:

- a. In Step 1, the seven major ACCS functions (listed below) were used to develop a functional breakdown. There are five levels of breakdown: function, sub-function, key task, task, and sub-task. This functional breakdown is a systematic, detailed description of all the ACCS activities that must be performed.
 - Force Management (FM)
 - Air Space Management (ASM)
 - Command and Control Resource Management (C²RM)

¹ An entity is defined as "an organizational unit which performs a unique set of interrelated and integrated functions to accomplish an operational objective."

² This process is completely described in *Supporting Document 4: Structure and Characteristics of Organizational Components to Volume IV, ACCS Master Plan (U)*, UNCLASSIFIED.

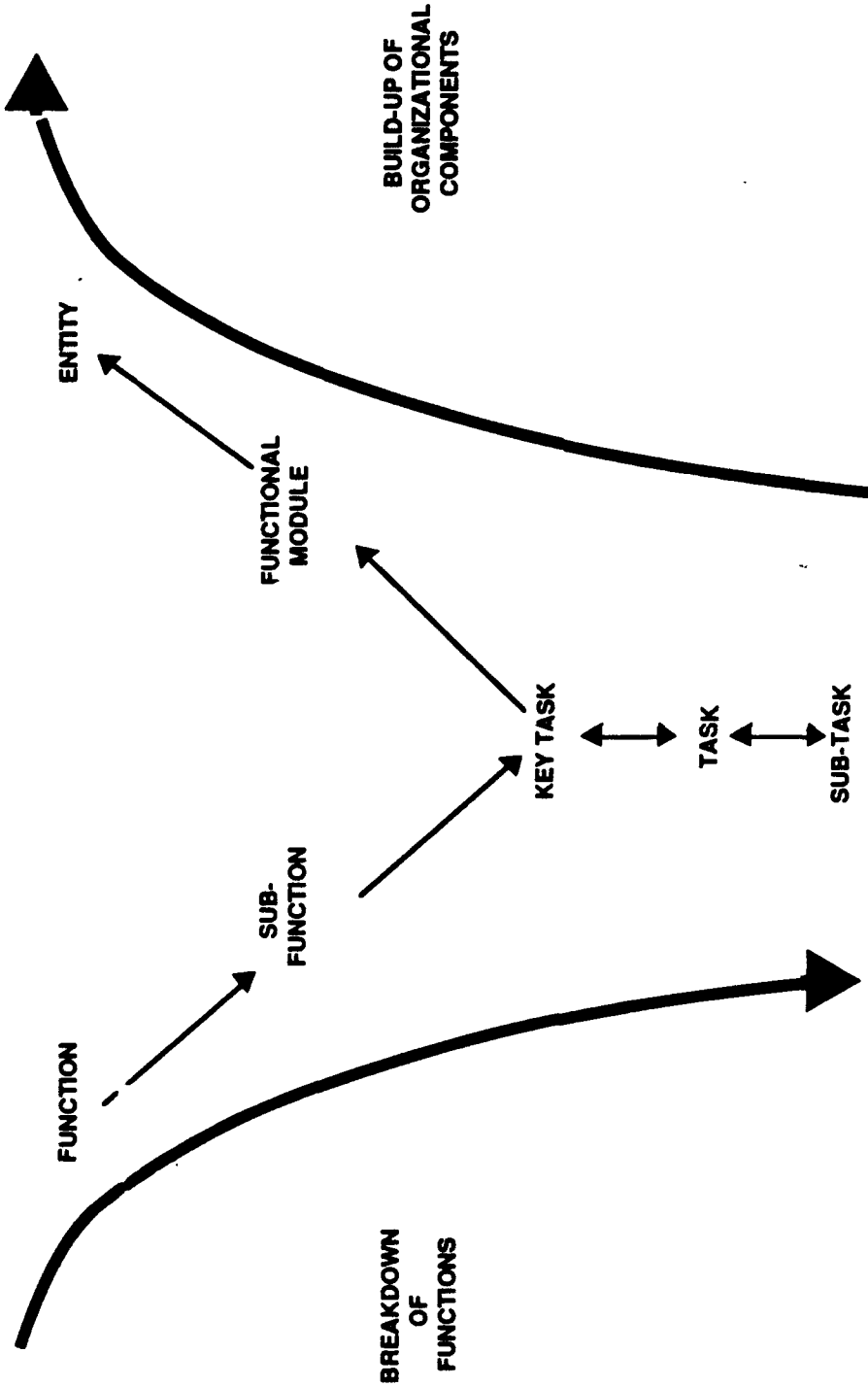

Figure 9. Functional System Design Approach

UNCLASSIFIED

- Surveillance (S)
 - Air Mission Control (AMC)
 - Air Traffic Control (ATC)
 - Information Exchange (INEX)
- b. Step 2 defined the functional modules. The functional key tasks described in the functional breakdown were assembled into logical groups. The rationale for this process was that command and control takes place in the following sequence: situation analysis, planning, directing, and controlling. Additionally, each functional module has the inherent tasks of information gathering (data in) and information distribution (data out). The functional modules are the building blocks of the organizational structure and represent functional elements of ACCS entities.
- c. In Step 3 the ACCS entities were developed by making a logical grouping of functional modules. The grouping selected was the one that reflected the interrelationships among and between modules. The groupings of functional modules describe the functional performance of an ACCS entity.

The application of this approach resulted in the development of the ACCS entities and the overall ACCS organizational structure. A significant result was that the Control and Reporting Centre (CRC) of the NADGE system could be divided into three separate entities: the Sensor Fusion Post (SFP), the Recognized Air Picture (RAP) Production Centre (RPC), and the Air Control Centre (ACC). These three entities, while functionally separate, can be collocated or separated as the operational situation requires.

Survivability was also enhanced by this functional decomposition of the detection, tracking, and RAP generation processes. The functional division provides modularity, redundancy, and the ability to reconfigure in the event of damage. All sensors are now remote from the SFPs, which can provide fusion of sensor data, perform sensor management for more effective surveillance, and control the ECCM features of its attached radars. The RPC can now accept tracks from its SFPs and from any track source, such as an NAEW or maritime source, and perform effective aircraft track management and correlation. This allocation of tasks helps prevent the sensor flow rates from flooding the data network.

The generic ACCS system entities and organization (depicted in Figure 10) was produced using the functional approach and by taking into consideration SHAPE's operational requirement to integrate defensive, offensive, and support operations,

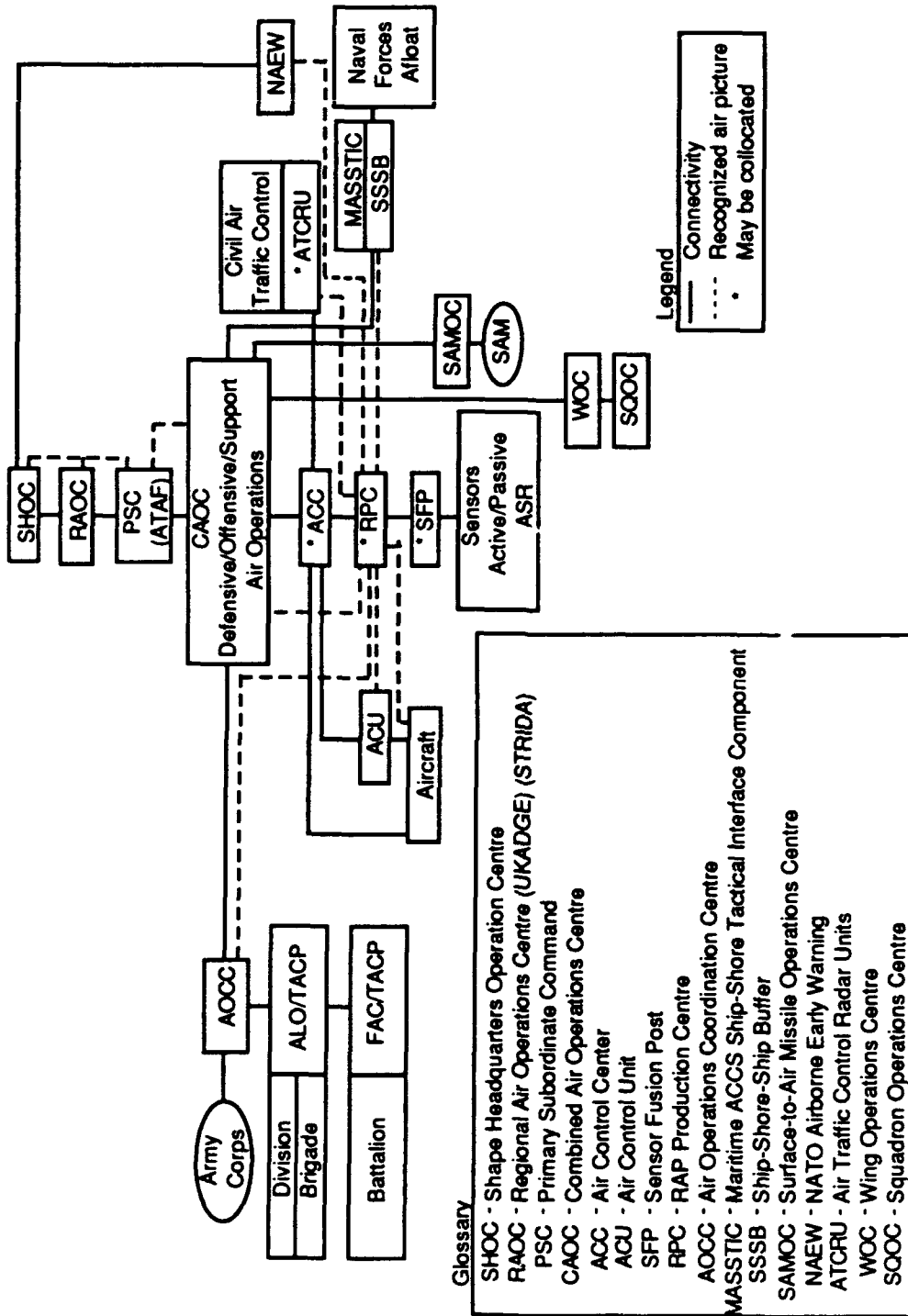

Figure 10. NATO Air C2 System

UNCLASSIFIED

combined with the doctrine of centralized command and decentralized execution of tasks. The lines shown should not be equated with command. The ACCST was only concerned with functional control relationships and the lines therefore reflect only connectivity. The ACCS concept combines the formerly separate offensive and defensive air operations at the PSC (ATAF) into an integrated planning and tasking staff. Similarly, the Air Tasking Operations Centre (ATOC) for offensive air operations and the Sector Operations Centre (SOC) for defensive air operations are integrated into a Combined Air Operations Centre (CAOC). As stated above, the CRC was functionally divided into its logical parts (ACC, RPC, and SFP), so the three entities can be collocated or separated as regional requirements dictate. The ACCS/Army Corps interface entity combines the formerly separate Air Support Operations Centre (ASOC), operated by the Air Force, and the Air Defense Operations Liaison Team (ADOLT), operated by SAM forces, into the Air Operations Coordination Centre (AOCC). The fully functional Maritime ACCS Ship and Shore Tactical Interface (MASSTIC) replaces the limited Ship-Shore-Ship Buffer (SSSB) and provides all tactical information exchange between ACCS and maritime forces afloat and maritime headquarters ashore.

The **Combined Air Operations Centre (CAOC)** is immediately below the ATAF level. This entity is planned to perform tasking functions for all air missions of subordinate NATO forces and to coordinate air operations tasking by other NATO and national air forces. The CAOC replaces the existing ATOC for offensive air operations and the SOC for defensive air operations. Below the CAOCs are the various execution level C² entities which control the execution of assigned air missions. The major ones include:

- **Air Control Centre (ACC)** -- These entities provide degrees of control and control support for defensive air missions (including SAM) for offensive and for support air missions. ACCs constitute the main air mission control/ battle management capability.
- **Air Control Unit (ACU)** -- Subordinate to the ACCs, the ACUs are capable of providing the same battle management and air mission control capabilities as the ACC, with the exception of SAM control. ACUs are physically smaller entities, normally mobile, and primarily intended to fill gaps in air control.
- **Reporting Post (RP)** -- This surveillance entity, consisting of either an active or a passive sensor, detects, signal-processes, and forwards data on air objects to the Sensor Fusion Post (SFP).

UNCLASSIFIED

- **Sensor Fusion Post (SFP)** -- This entity controls assigned RPs (up to a maximum of 12 sensors) with an additional capacity (of 12 sensors) for back-up purposes. The SFP fuses the data received from its attached RPs and establishes local tracks. The local track data is forwarded to the next level for processing. The SFP does not make track identifications; this authority is reserved for the superior ACCS surveillance entities.
- **Recognized Air Picture (RAP) Production Centre (RPC)** -- This entity receives track data from its assigned SFPs, NAEW, maritime, and any other source that produces air tracks. In producing the RAP for its assigned AOR, the RPC performs track management, identifies targets, and assigns NATO track numbers. The RPC distributes the RAP data to all users. The RAP is proposed to be updated every 5 seconds.
- **Air Operations Coordination Centre (AOCC)** -- The ACCS entity proposed to provide an interface with Army forces, an AOCC (which replaces the current ASOC) is collocated with each Army corps headquarters and reports to a CAOC. It performs the function of coordinating air operations with Army ground and air operations.
- **Maritime ACCS Shore and Ship Tactical Interface Component (MASSTIC)** -- The MASSTIC provides tactical information exchange between the land based ACCS and naval forces afloat.
- **Wing Operations Centre (WOC)** -- The C² facility controlling airbase/airfield operations, the WOC also distributes Recognized Air Picture (RAP) data to all airbase/airfield users. The Squadron Operations Centre (SQOC) performs a similar mission at the squadron level.
- **Air Traffic Control Radar Unit (ATCRU)** -- ATCRUs provide the basis for military air traffic control of non-combat and combat missions before entering and after leaving forward combat areas.
- **Surface-to-Air Missile Operations Centre (SAMOC)** -- Within the Central Region (CR) there is a large deployment of mixed SAM weapons. To control these different systems in the CR, the SAMOC is proposed. The SAMOC is a mobile unit functionally subordinate to the ACC and responsive to battle management functions performed at the CAOC/ACC.

A comparison of the ACCS organizational structure with the present organizational structure is provided in Figure 11.

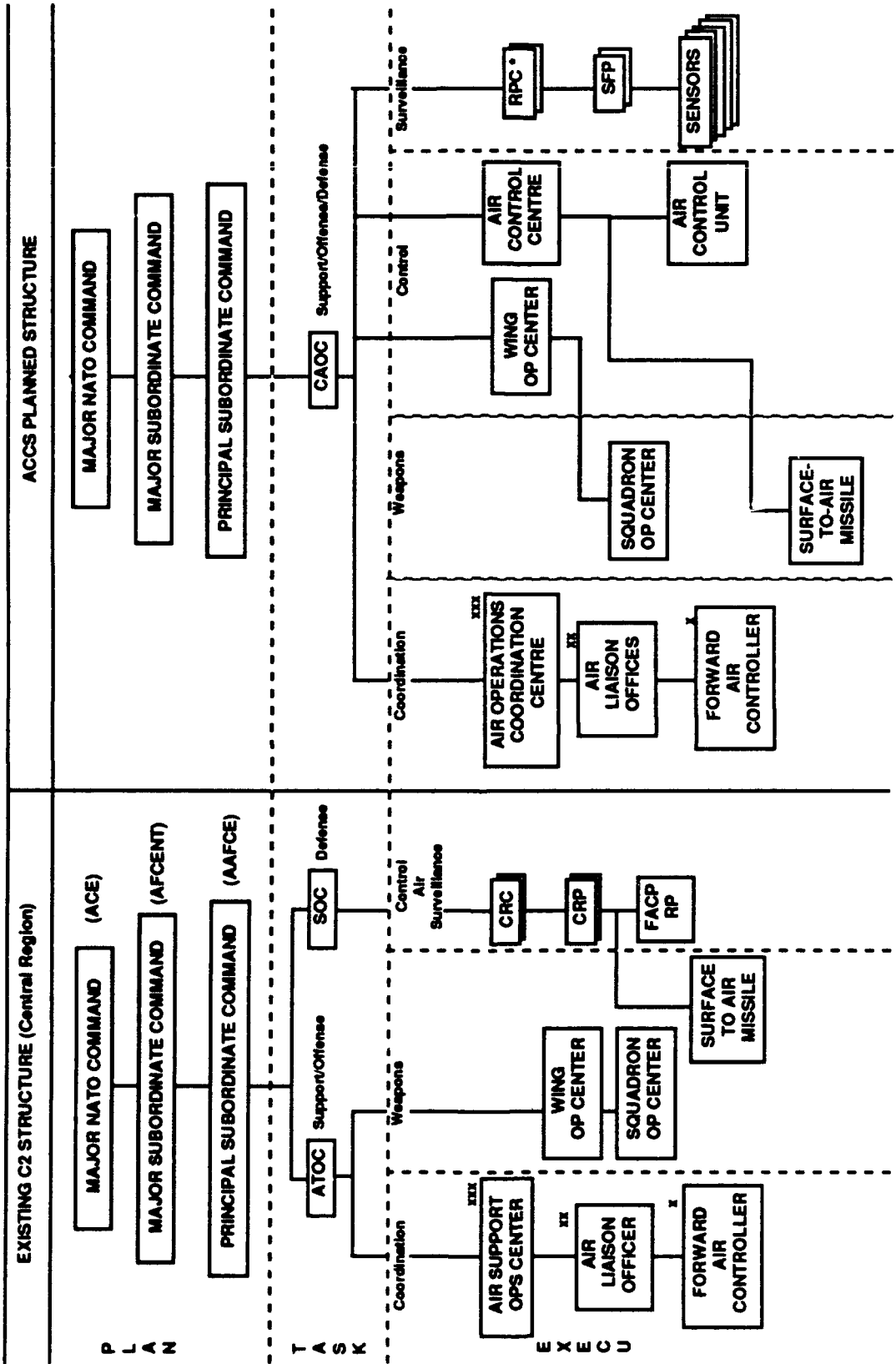

* The Recognized Air Picture (RAP) is passed to all users.

Figure 11. Existing and Planned NATO Air C2 Systems

UNCLASSIFIED

The ACCS entities are heavily automated to cope with modern, high-speed air warfare and attain survivability through redundancy. This capability is provided by implementing the ACCS functions in a combination of flexible, high-capacity, digital machines and work stations connected via redundant, wide-band local area networks (LAN). The LANs are interconnected by redundant communications processors linked to the high-capacity ACCS packet-switched digital network. To minimize costs, common Ada-based, reusable software -- centrally developed and maintained, with a high degree of hardware independence -- is used. To simplify information display, only two types of work stations were selected: one for surveillance data display, and one for management information. A typical entity configuration is shown in Figure 12.

Communications processing is essential to interface the entity to the supporting communications. The communications processor accepts data messages, decodes them, and sends the data received via the internal LAN to the entity computers for further use. Similarly, voice traffic is routed to the internal private automatic branch exchange (PABX) for connection to the appropriate individual. Outgoing data is routed via the LAN to the communications processor. The processor formats the data, applies the necessary addresses and protocols, and sends it via the transmission plant to its destination.

Review of the Phase 1 Transition Plan and supporting documents shows that these communications processors are being procured by ACCS as a part of the entities. The ACCS IMG Statement of Work states that "communications requirements shall be specified to the extent necessary to determine the throughput and size requirements for the communications processor (layers 1-4 of the ISO-OSI model), and equipment interface between communication systems, the gateway/interface with NATO/national communication systems and the ground area networks interface to ground-air-ground communications."

B. CENTRAL REGION

The Central Region (CR) is a key defensive area of NATO. It is a complex area, being composed of the nations of Germany, Belgium, and the Netherlands. In addition, located within Germany, are the military forces of the United States, France, and the United Kingdom, as well as forces of Belgium, the Netherlands, and Canada. The area has a highly developed industrial infrastructure, dense urbanization, excellent land lines of communications, and a well-developed aviation infrastructure.

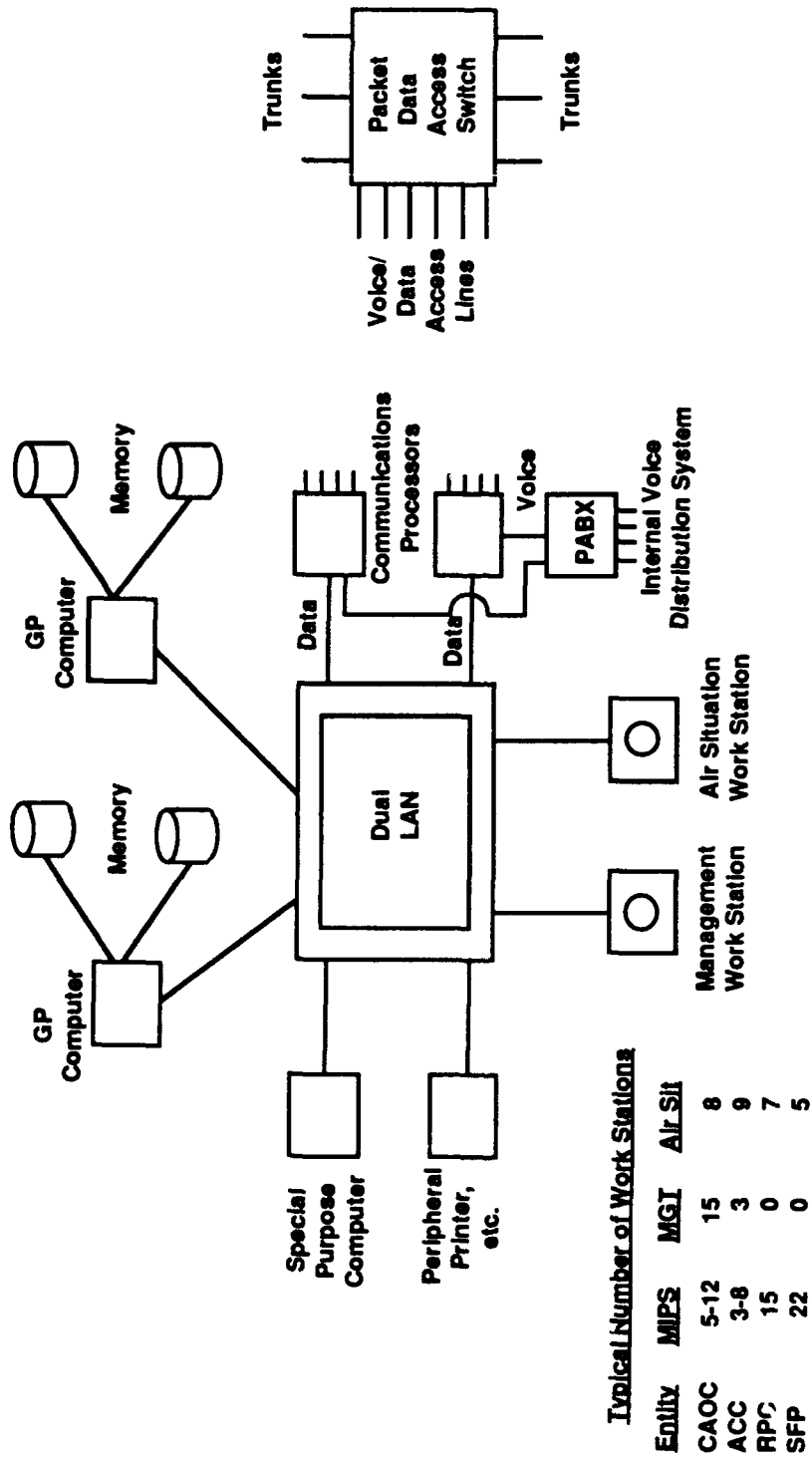

Figure 12. Schematic Representation of Typical ACCS Entity

UNCLASSIFIED

Within the Central Region air planning activities are performed at the senior command levels of the MNC, namely the SHAPE Primary War Headquarters (PWHQ) and the Major Subordinate Headquarters (MSC) [Allied Forces Central Europe/Allied Air Forces Central Europe (AFCENT/AAFCE) PWHQ]. The air planning functions at MSC level are performed by the Commander, Allied Air Forces Central Europe (COMAAAFCE),³ who directs the employment of CR air forces to achieve regional objectives in accordance with guidance given by Commander-in-Chief, Central Region (CINCENT). The detailed air planning activities together with the required coordination with outside agencies is concentrated at the PSC level. Owing to the size and complexity of the CR, there are two PSCs: Northern Army Group/2d Allied Tactical Air Force (NORTHAG/2ATAF) and Central Army Group/4th Allied Tactical Air Force (CENTAG/4ATAF).

Below the ATAF level are the CAOCs. To equitably distribute the operations loading and to provide a consistent command structure in the CR, four CAOCs, each with an area of responsibility (AOR), have been established as depicted in Figure 13. The CR command structure is depicted geographically in Figure 14. 2 ATAF includes Sectors 1 and 2; 4ATAF includes Sectors 3 and 4. The Sector 2/3 boundary coincides with the 2ATAF/4ATAF boundary. The boundaries of the area of responsibility (AOR) are, however, flexible and can be changed as required.

The ACCs and ACUs planned for the CR are depicted in Figure 15 and summarized in Table 9. These are peacetime locations, and do not include the U.S. Modular Control Equipment (MCE), which is considered to be equivalent to an ACU. Allowance has been made within the CR for the inclusion of 12 ACUs (MCE) in addition to the six ACUs shown.

The SAM Operations Centre (SAMOC) is the element above SAM battalions that exercises control over mixed SAM weapons systems. The SAMOC is tasked operationally by the CAOC, which has overall area air defense responsibility. However, for direct execution of defensive air warfare missions the SAMOC is battle-managed by the ACC. In general there are three SAMOCs per sector, except for Sector 3 which requires four SAMOCs. A total of 13 SAMOCs are planned to be deployed within the CR.

³ Technically, AAFCE is at the PSC level, rather than at the MSC level. However, COMAAAFCE is responsible for planning at the MSC level.

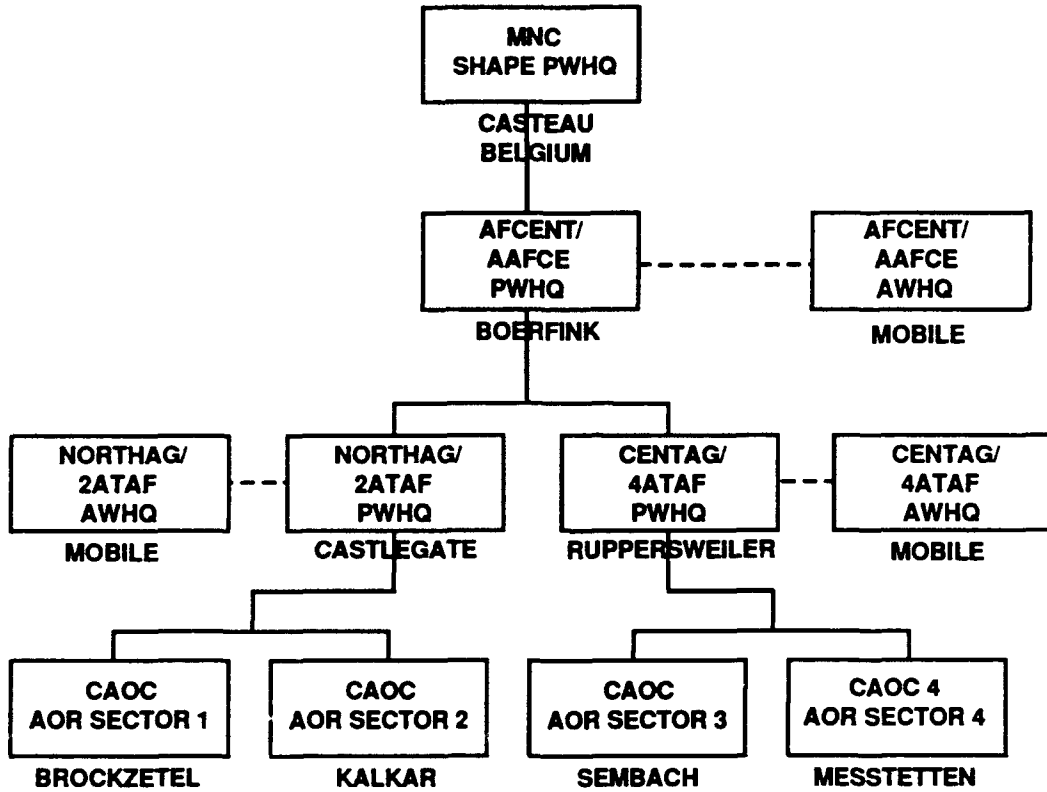

Figure 13. Central Region Command Structure

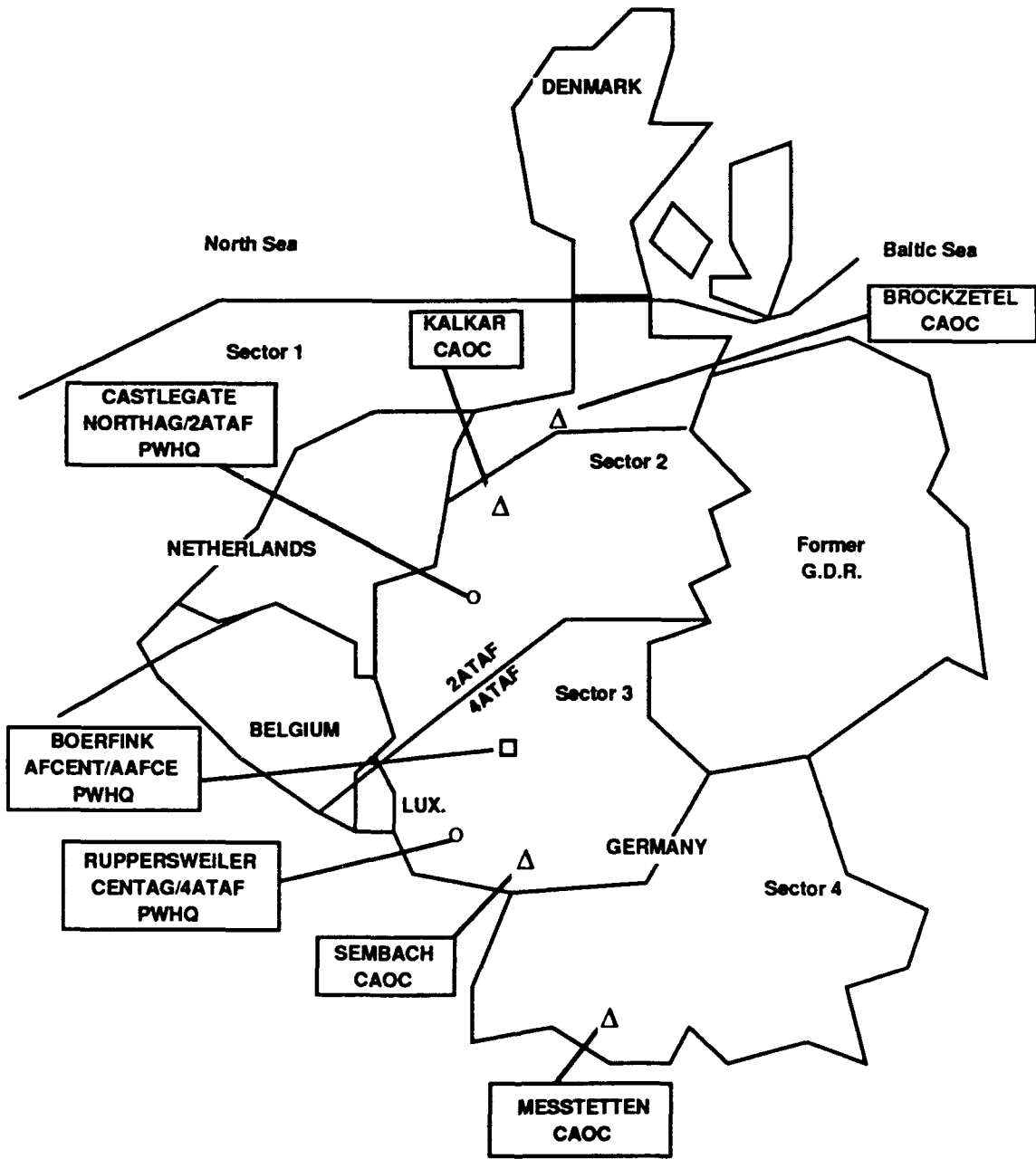

Figure 14. AOCs Headquarters Locations In the Central Region

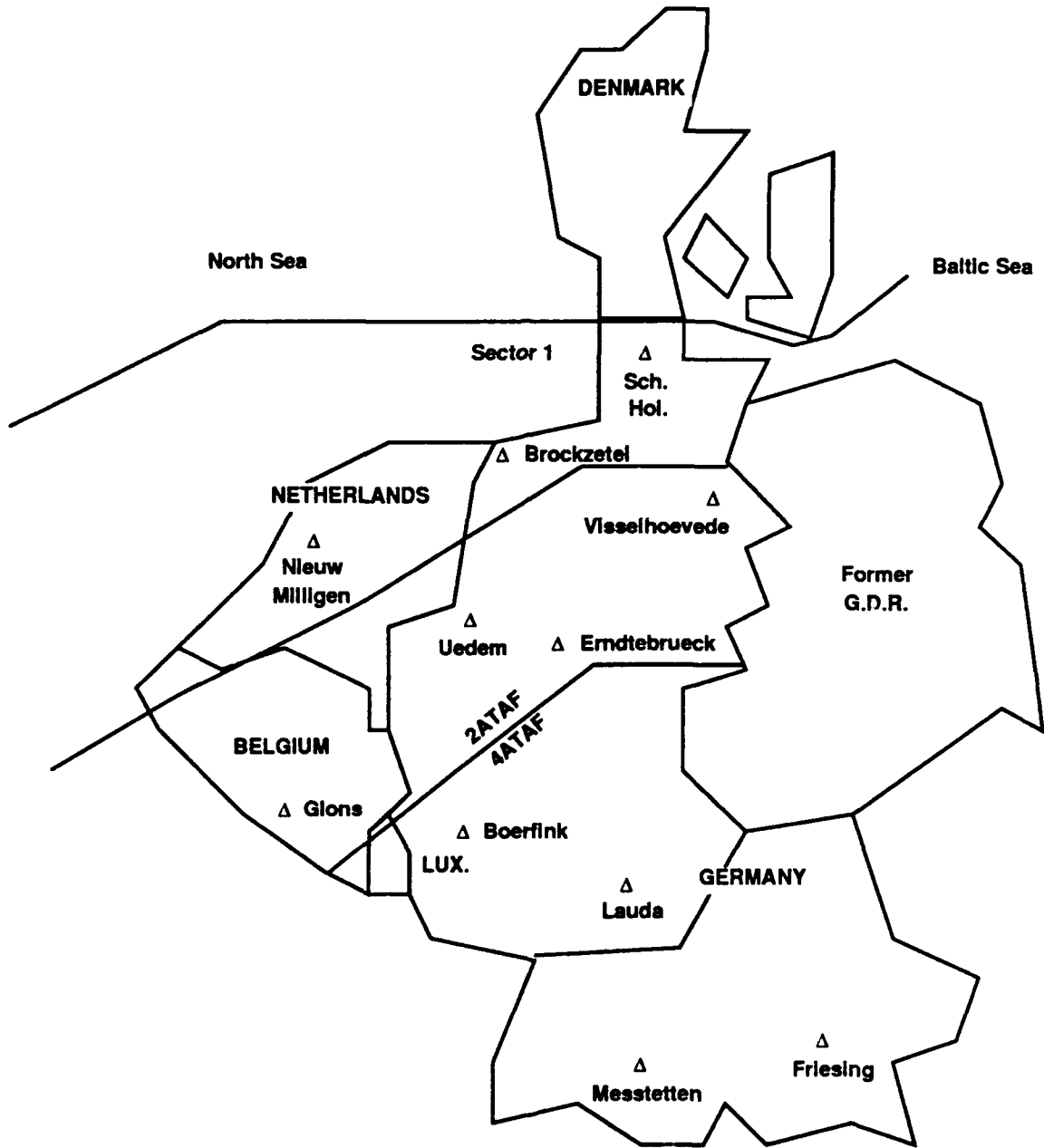

Figure 15. Air Control Centre Locations in the CR

UNCLASSIFIED

Table 9. Planned ACCs and ACUs in the CR

Sector	ACC	ACU
1	Schleswig-Holstein (GE)	Glucksburg (GE)
	Brockzetel (GE)	
	Visselhoevede (GE)	Auenhausen (GE)
	Nieuw Milligen (NL)	
2	Uedem (GE)	Auenhausen (GE)
	Erndtebrueck (GE)	
	Glons (BE)	
3	Boerfink (GE)	
	Lauda (GE)	Lauda (GE)
4	Messtetten (GE)	Freising (GE)
	Freising (GE)	Lechfeld (GE)

In the Central Region the civil air traffic control is exercised only in the air corridors. Off-corridor traffic is a military responsibility. This explains the need for Air Traffic Control Radar Units (ATCRU) in the ACCS structure in this region. There are eight ATCRUs planned for the Central Region. They are all collocated with their civil air traffic control counterparts to simplify the coordination of military and civil air traffic control. ATCRU locations are shown in Table 10.

Table 10. Planned ATCRUs In the CR

Sector 1	Nieuw Milligen	NL
	Bremen	GE
Sector 2	Masstricht	NL
	Semmerzake	BE
	Duesseldorf	GE
Sector 3	Karlsruhe	GE
	Frankfurt	GE
Sector 4	Munich	GE

UNCLASSIFIED

ACCs, RPCs, and SFPs are planned to be located within the Central Region as shown in Table 11 below.

Table 11. Planned Surveillance Entities in the CR

ACC	RPC	SFP
Sch.-Holstein	Sch.-Holstein	Sch.-Holstein I
Brockzetel	Brockzetel	Brockzetel Wittmund
Visselhoevede	Visselhoevede	Visselhoevede Auenhausen
Nieuw Milligen	Nieuw Milligen	Nieuw Milligen
Uedem	Uedem	Uedem Erntebueck
Glons	Glons	Glons Semmerzake
Boerfink	Boerfink	Boerfink Bitburg
Lauda	Lauda	Lauda I Lauda II
Messtetten	Messtetten	Messtetten
Freising	Freising	Freising Lechfeld Sch.-Holstein II
Erntebueck	-	-

Three MASSTICs are planned for the Central Region: one each at Nieuw Milligen, Brockzetel, and Gluecksburg.

The complete ACCS organization within the Central Region is depicted in Figures 16 and 17. The lines on the organizational charts are not to be construed as command lines. The lines only represent information flow from higher to lower levels and vice versa. Information flow is discussed in detail in Chapter II.

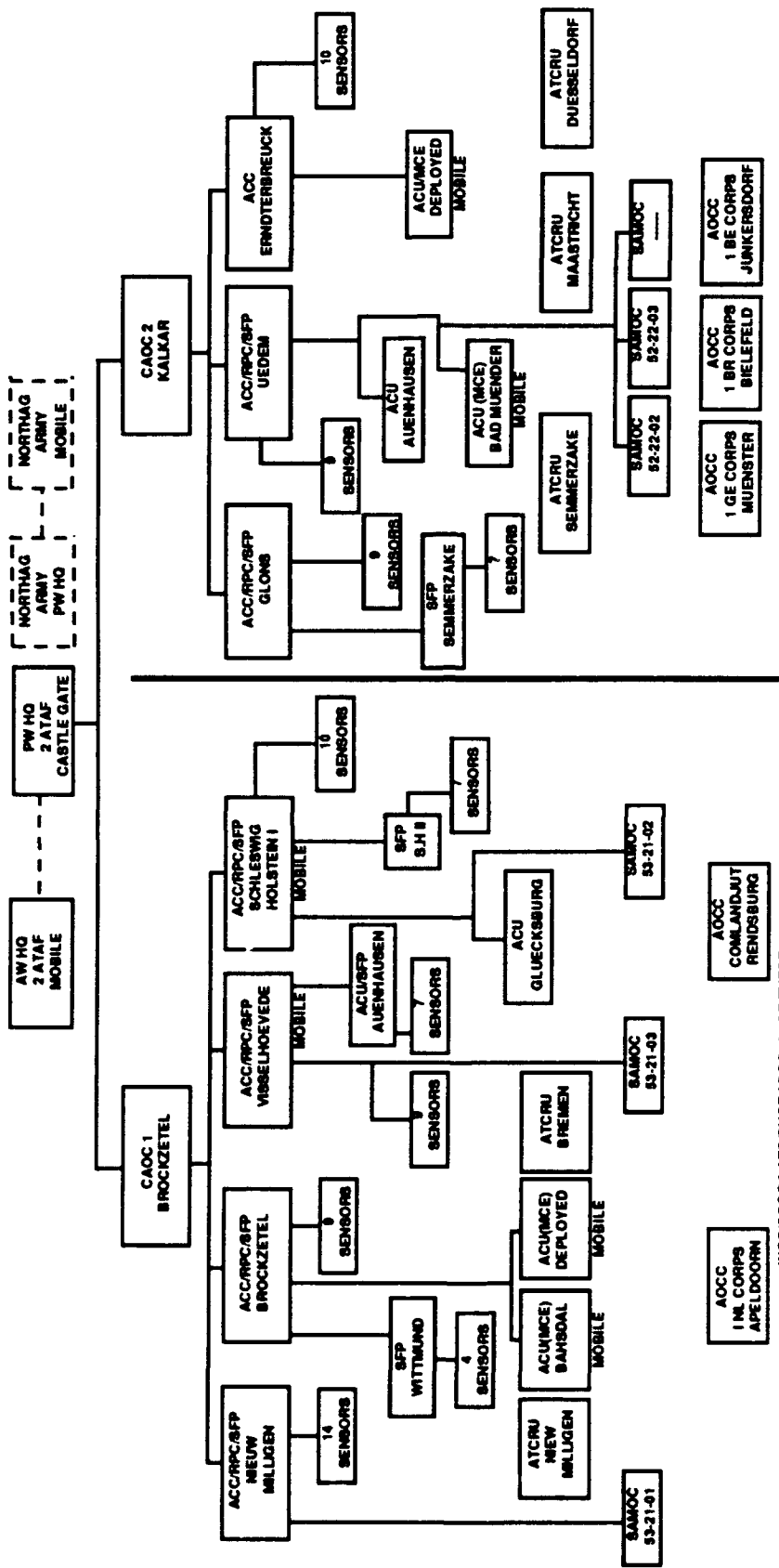

SECTOR 2

SECTOR 1

WOC/SOOC/LATC/SORADOC (50 OF THESE)

Figure 16. 2ATAF ACCS

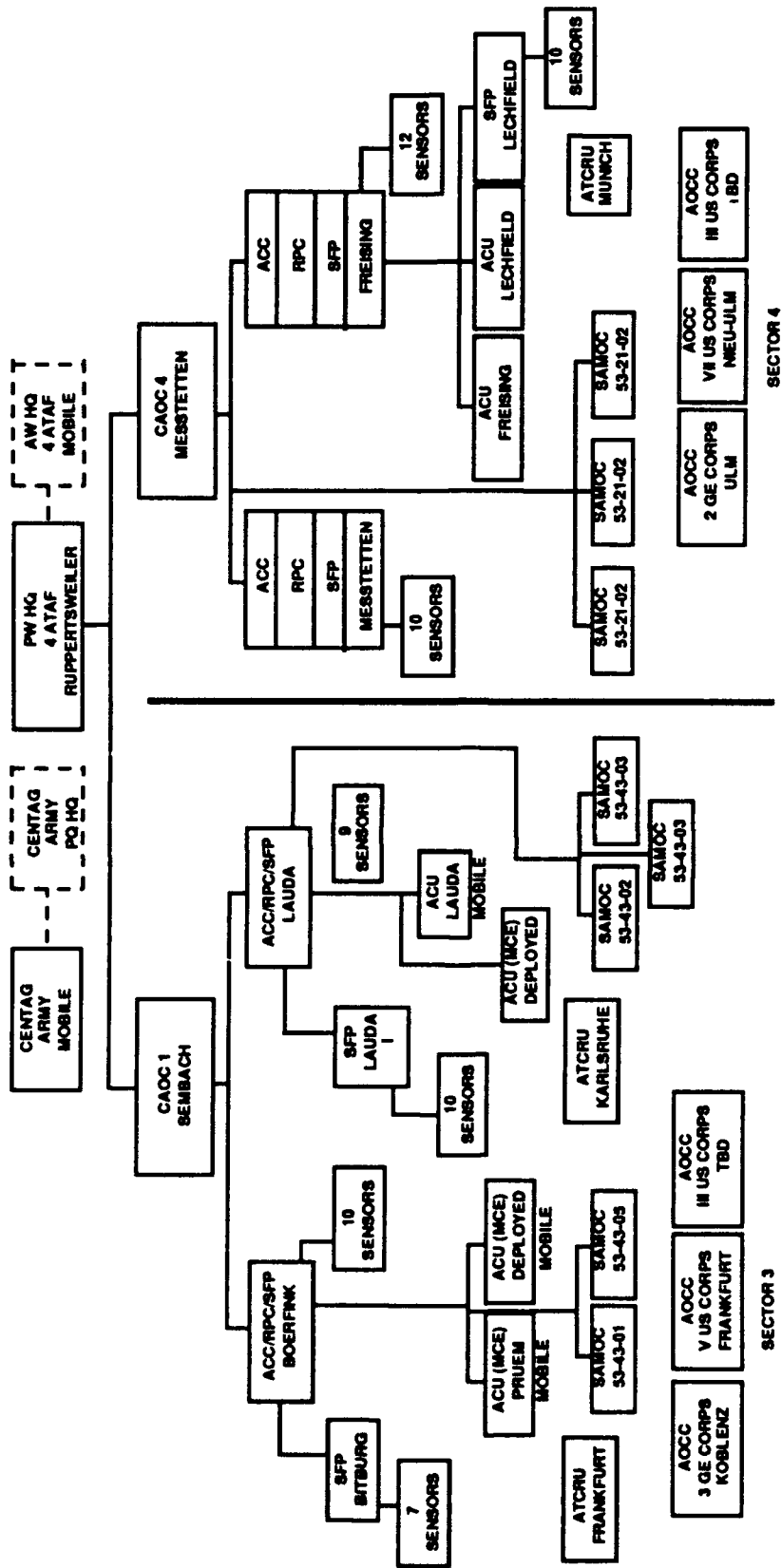

Figure 17. 4ATAF ACCS

UNCLASSIFIED

C. FIFTH ALLIED TACTICAL AIR FORCE (5ATAF)

5ATAF in Italy, a part of the NATO Southern Region, is a sensitive area of NATO. Italy is a complex defensive area. Flight times from Warsaw Pact countries are relatively short, there are potential threats from nations along the African littoral, and the Mediterranean Sea is a prime operating area for the Soviet Navy. As a result, there is a multidirectional sea and air threat covering almost 270 degrees. Additionally, 5ATAF's NATO partners in the Southern Region -- Spain, Greece, and Turkey -- are separated by large areas of water, and Italy is separated from the Central Region by the neutral nations of Switzerland and Austria. Compared to the Central region, the area has a less well-developed industrial infrastructure, with correspondingly less developed communications networks.

The ACCS organizational structure for 5ATAF is depicted in Figure 18. The lines on this chart should not be construed as command lines. These lines only represent connectivity and information flow between entities.

For 5ATAF, air allocation is performed at the MNC SHAPE Primary War Headquarters (PWHQ) and the Major Subordinate Command (Allied Forces South and Air South).⁴ Overall air planning and supervision of air assets are performed for the Southern Region by the Senior PSC, Air South. The Junior PSC, 5ATAF, is located at Affi, Italy, in its Primary Static War Headquarters (called WESTSTAR). Its alternate war headquarters (called BACKYARD) is located nearby. Immediately below 5ATAF is the CAOC. There are two CAOCs: one at Monte Venda for northern Italy, and one at Martina Franca for southern Italy. Collocated with each CAOC is an RPC. Additionally, underscoring the importance of maritime operations in 5ATAF, a Maritime Operations Centre and an Air Operations Coordination Centre are collocated within each CAOC. These are shown in Figure 19, which depicts the ACCS headquarters locations in 5ATAF.

Below the CAOCs are the execution level ACCS entities that control air missions. Within 5ATAF, 4 Air Control Centres (ACC) have been designated: Poggio Balone and Poggio Renatico in the north, and Licola and Siracusa in the south. These and other ACCS locations are shown in Figure 20. Each ACC has an RPC and a SAM cell.

⁴ Technically, Air South is at the PSC level, rather than at the MSC level. However, Air South is responsible for planning at the MSC level.

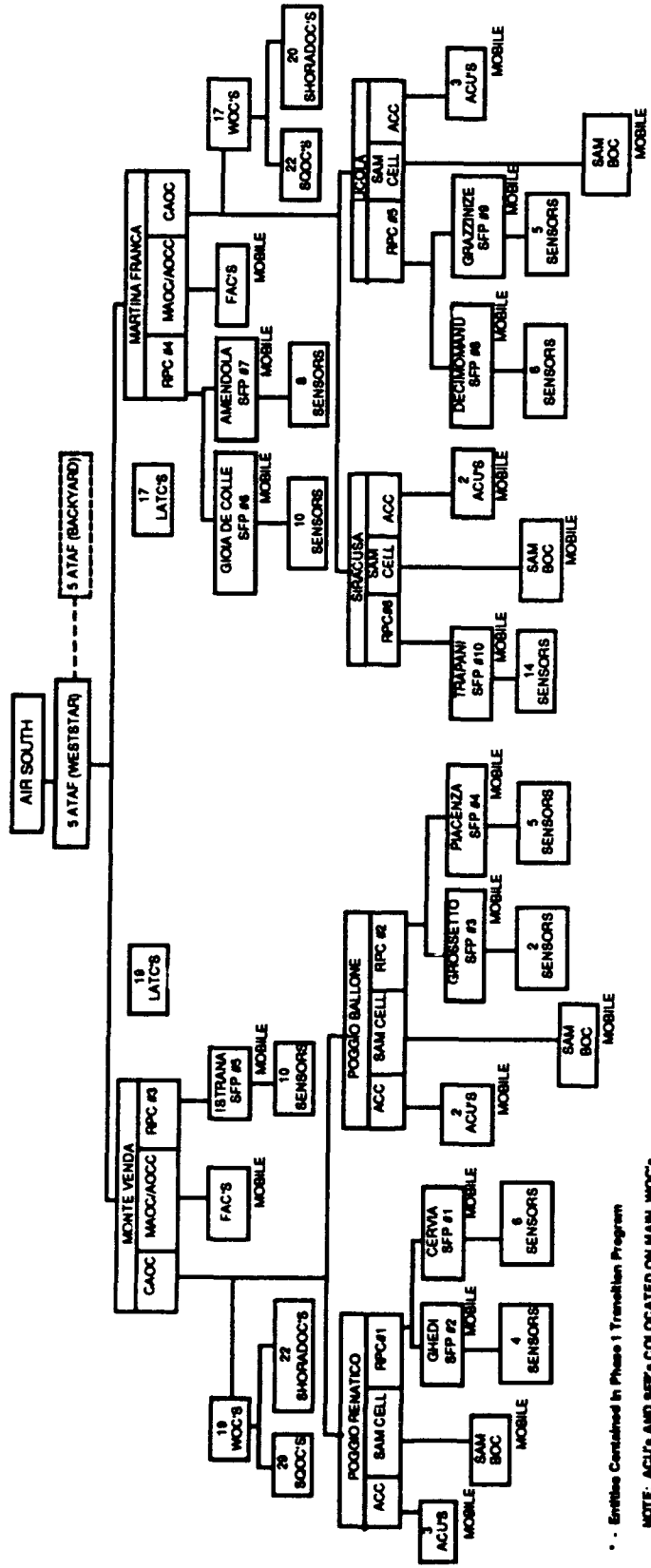

.. Entities Contained in Phase 1 Transition Program
 NOTE: ACU's AND SFP's COLOCATED ON MAIN WOC's

Figure 18. 5ATAF ACCS

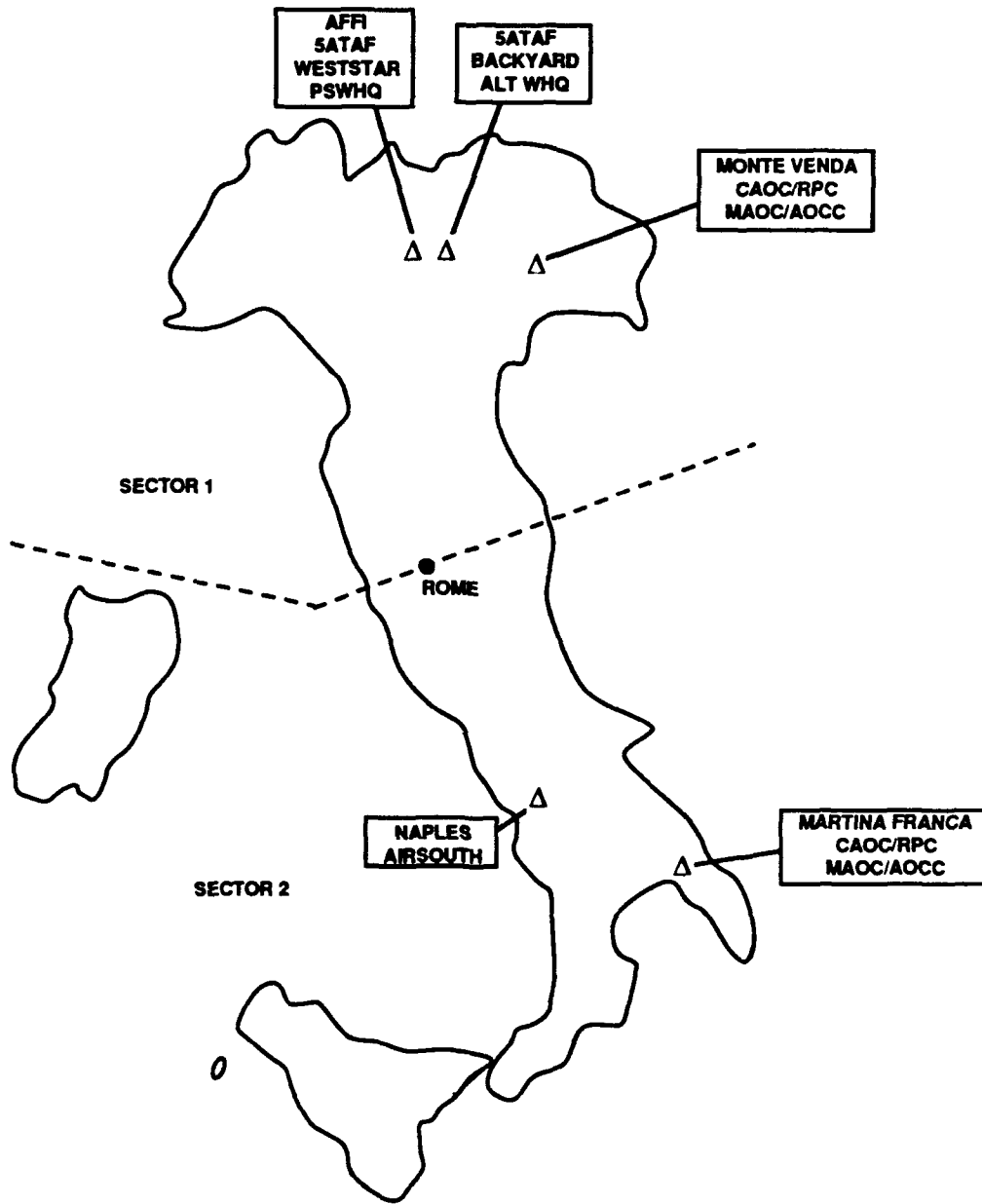

Figure 19. ACCS Headquarters Locations in 5ATF

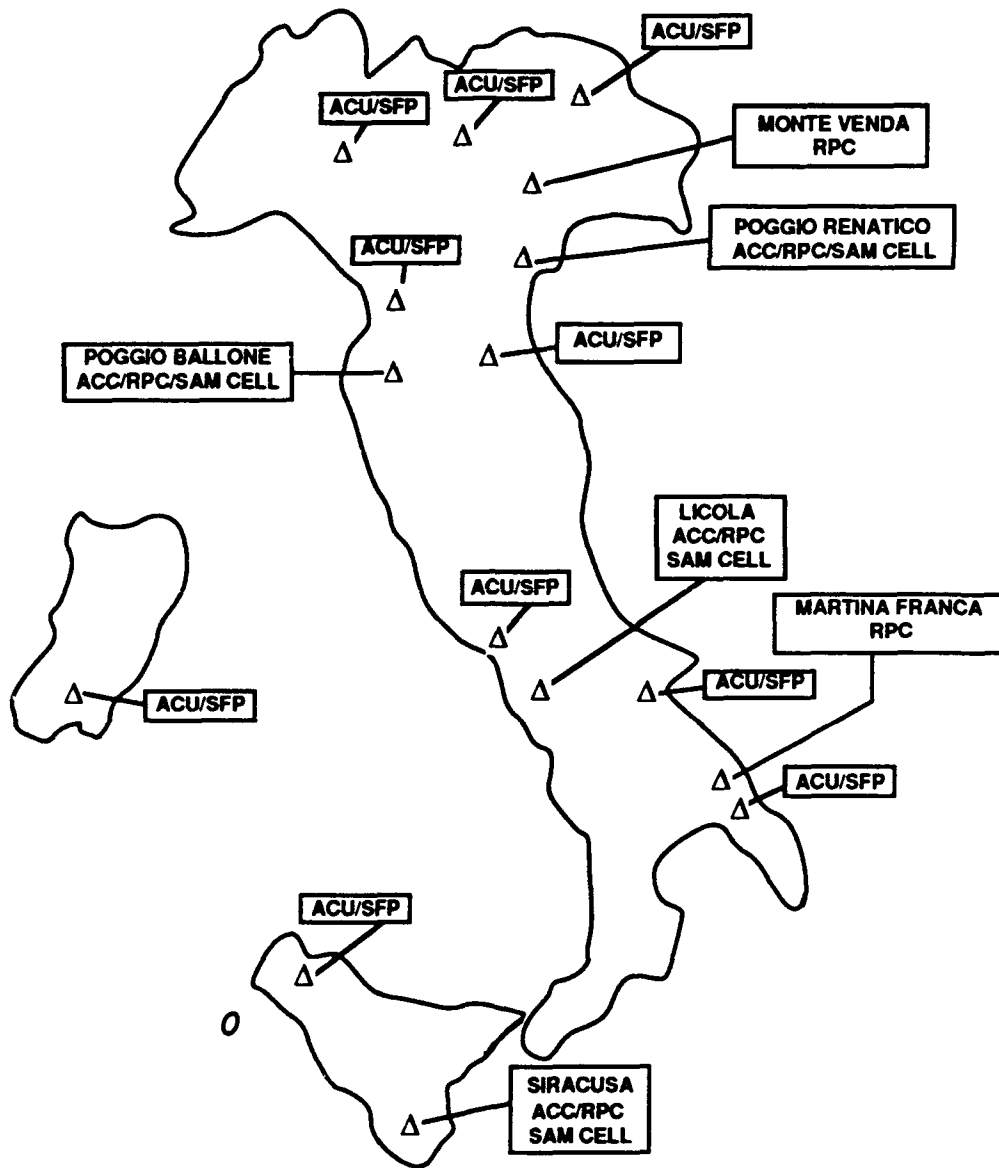

Figure 20. ACC, ACU, and Other ACCS Locations in 5ATAF

UNCLASSIFIED

In view of the long, narrow, mountainous geography of Italy, a mobile ACU concept was used for survivability. Ten mobile ACUs are based at various air bases and deployed as needed; the ACU locations shown in Figure 20 are notional. Ten mobile SFPs are provided to operate with each ACU. The SFP, although a separate entity, would normally operate alongside its associated ACU. The SFPs also have an additional assignment to provide sensor data to the four RPCs. Four Air Traffic Control Centres (ATCC) are located at Milan, Padova, Rome, and Brindisi. No unique ACCS items are planned for these ATCCs other than an interface to allow exchange of airspace management, air traffic control, RAP, and flight plan data.

D. TRANSITION PLANNING

NATO intends that the ACCS will evolve from the existing NATO Air Defence Ground Environment (NADGE) over a period of years. To develop an affordable ACCS transition plan, NATO formed the Special Working Group (Transition) [SWG(T)] reporting to the Panel on Airspace Management and Control Systems (PAMCS). The SWG(T), comprised of NATO and national experts, was established for the sole purpose of preparing an ACCS Phase 1 Transition Programme covering the period 1991-1996. This Phase 1 Transition Programme, which includes NATO and nationally funded ACCS elements, is intended to be coherent throughout NATO Europe. Further, the programme was to be operationally acceptable, technically sound, and within established budget constraints. The transition was expected to be programmed in Slices 42-47 (1991-1996) for its NATO-funded part. The Phase I goals of the SWG(T) were to:

- Initiate the ACCS build-up by implementing the core ACCS elements (CAOC, AOCC, WOC, SQOC, ACC, ACU, RPC, SFP) together with the necessary communications
- Continue to maintain the current systems at an acceptable operational level
- Adhere to realistic budget levels.

The NATO-funded Integral ACCS (IA) projects were selected by the SWG(T) to satisfy the military needs and priorities for Phase 1. The NATO funding for the 6-year Phase 1 Programme included a 70 MIAU per year (420 MIAU total) planning figure provided by SACEUR and an additional reserve amount of approximately 180 MIAU (total) to ensure that the 420 MIAU would actually be spent during the 6-year period. This level of over-planning was to compensate either for the non-realization of some projects in the planning year, or to fund additional projects in the event funding above the planning

UNCLASSIFIED

figure of 70 MIAU per slice became available. In addition to the NATO infrastructure funds, the nations planned collectively to expend approximately 900 MIAU for Integral ACCS projects in 1991-1996.

The Phase 1 Transition Programme, developed by the SWG(T) and based on the ACCS design concept detailed in the ACCS Master Plan, concentrated on the development and implementation as soon as possible of the ACC, ACU, SFP, RPC, CAOC, AOCC, WOC, and SQOC entities. At the same time, older radars would continue to be replaced, bunkers for new entities would be built, and minimal improvements, such as the Ship-Shore-Ship Buffer (SSSB) would be made to existing systems. Most of the Phase 1 effort was planned for the higher priority Southern and Central Regions.

The Phase 1 Transition Programme also provides for funding support of the ACCS program support (system integration engineering) software development, radar replacement, new radars, bunkers for ACCS entities, and minimal improvements to the existing system. These items are not considered here, as they do not affect transition to ACCS. The plan states that to ensure the full operational capability of the new ACCS sites concurrent with ACCS transition, respective nations must plan the required communication network to support the interconnection of the ACCS sites. Therefore, it is clear that nations that are scheduled to receive ACCS entities must ensure that the required communications are available.

Table 12 summarizes the ACCS entity implementation plans. For clarity, and to show the need for cross-border communications channels to entities planned for adjacent regions, France and BALTAP are shown in addition to the Central Region and 5ATAF. A planned SSSB implementation is shown, as this entity provides the initial maritime interface, to be replaced by the MASSTIC at a later date. Similarly, planned ATCRUs are also shown.

Table 13 shows a comparison of the ACCS entities planned for the Central region and 5ATAF by the ACCS Master Plan, and those selected by the SWG(T) for the Phase I Transition Programme. The last column shows what portion of the ACCS was to be implemented in the Central Region and 5ATAF in the near-to-mid term. The concentration is in the 2ATAF and Northern Italy areas. This is in accordance with NATO priorities. The transfer of data between these entities will require cross-border connections between the communications networks.

UNCLASSIFIED

Table 12. NATO-Funded ACCS Elements in the CR and 5ATAF

Area	Location	Entity	Implementation								
			42	43	44	45	46	47	48+		
			1991	92	93	94	95	96	97+		
BALTAP	Skagen	ACU/RPC/SFP									
	Skydstrup	ACU(MOBILE) ACC/RPC/SFP									
Central Region	Nieuw Milligen	ATCRU									
	Nieuw Milligen	ACC/RPC/SFP									
	Nieuw Milligen	SSSB									
	Semmerzake	ATCRU									
	Semmerzake	SFP									
	Messtetten	CAOC									
	Sembach	CAOC									
	Kalkar	CAOC									
	Brockzetel	ACC/RPC/SFP									
	Uedem	ACC/RPC/SFP									
France	Glons	ACC/RPC/SFP									
	Ernd Tebrueck	ACC/RPC/SFP									
	Breckendorf **	ACC/RPC/SFP									
	Auenhausen *	ACC/SFP									
	Mount Verdun	CAOC/ACC/RPC/SFP									
	Mount Demarsan	CAOC/ACC/RPC/SFP									
	Doullens *	ACC/SFP									
	Contrexville *	ACC/SFP									
	5ATAF (Italy)	Monte Venda	CAOC/RPC/AOCC								
		Poggio Ballone	ACC/RPC/SFP								
Poggio Renatico		ACC/RPC/SFP									
N/A		1 ACU/SFP (MOBILE)									

* ACU/SFP by design; ACC/SFP capacity required for back-up role.

** Replaces Schleswig-Holstein.

UNCLASSIFIED

**Table 13. Comparison of ACCS Master Plan and ACCS Transition Plan
for the Central Region and 5ATAF**

Area	Location	Master Plan	Phase 1 Transition
Central Region Sector 1 2 ATAF	Brock Zetel	CAOC/ACC/RPC/SFP	ACC/RPC/SFP
	Schleswig-Holstein I	ACC/RPC/SFP	-
	Schleswig-Holstein II	SFP	-
	Breckendorf	-	ACC/RPC/SFP
	Nieuw Milligen (NL)	ACC/RPC/SFP	ACC/RPC/SFP
	Nieuw Milligen (NL)	ATCRU	ATCRU
	Nieuw Milligen (NL)	SSSB	SSSB
	Visselhoevede	ACC/RPC/SFP	-
	Wittmund	SFP	-
	Bremen	ATCRU	-
	Gluecksburg	ACU	-
	Gluecksburg *	SSSB	-
	Central Region Sector 2 2 ATAF	Kalar	CAOC
Uedem		ACC/RPC/SFP	ACC/RPC/SFP
Glons (BE)		ACC/RPC/SFP	ACC/RPC/SFP
Ernd Tebrueck		ACC/SFP	ACC/RPC/SFP
Semmerzake		ATCRU	ATCRU
Semmerzake		SFP	SFP
Maastricht		ATCRU	-
Dusseldorf		ATCRU	-
Auennhausen		ACU/SFP	ACC/SFP
Auenhausen **		ACU	-

* BALTAP Project

** Peacetime Location

UNCLASSIFIED

Table 13. (Cont'd)

Area	Location	Master Plan	Phase I Transition
Central Region Sector 3 4 ATAF	Sembach	CAOC	CAOC
	Boerfink	ACC/RPC/SFP	-
	Bitburg	SFP	-
	Lauda I	ACC/RPC/SFP	-
	Lauda II	ACU/SFP	-
	Frankfurt	ATCRU	-
	Karlsruhe	ATCRU	-
Central Region Sector 4 4 ATAF	Messtetten	CAOC/ACC/RPC/SFP	CAOC
	Freising	ACC/RPC/SFP	-
	Freising **	ACU	-
	Lechfield	ACU/SFP	-
	Munich	ATCRU	-
Italy Sector 1 5 ATAF	Monte Venda	CAOC/RPC/AOCC/MAOC	CAOCC/RPC/AOCC
	Poggio Renatico	ACC/RPC	ACC/RPC/SAM CELL
	Poggio Ballone	ACC/RPC	ACC/RPC/SAM CELL
	(Various)	5 ACU/SFP (MOBILE)	1 ACU/SFP (MOBILE)
Italy Sector 2 5 ATAF	Martina Franca	CAOC/RPC/AOCC/MAOC	-
	Licola	ACC/RPC/SAM CELL	-
	Siracusa	ACC/RPC/SAM CELL	-
	(Various)	5 ACU/SFP (MOBILE)	-

** Peacetime Location

II. THE ACCS GENERIC COMMUNICATIONS ARCHITECTURE

A. THE ACCS OVERALL CONCEPT FOR COMMAND AND CONTROL

At the tasking level, the ACCS combines the air defense, air offense and air support functions into one single entity, the Combined Air Operations Centre (CAOC). At the execution level the proposed C2 system functionally separates control and surveillance, which in the current system are combined.¹ In the ACCS the control function is performed by the Air Control Centre (ACC), the Air Control Unit (ACU), and the Wing Operations Centre (WOC).

Surveillance starts at the sensors where both active and passive sensors are netted to the Sensor Fusion Post (SFP). Each SFP is capable of netting up to 12 sensors. From this sensor data the SFP generates the local area picture. This picture together with correlated identification (ID) as well as non-correlated tracks is passed to the Recognized Air Picture (RAP) Production Centre (RPC). At the RPC these local area pictures are aggregated and correlated with information from other RPCs (track cross-tell), from flight plans and other data stored in databases, and from tracks coming from sources such as NATO air early warning (NAEW) and naval sensor platforms; the track then receives an ID and track number. Upon the resolution of conflicting data, the RPC generates the RAP and distributes it to all the users as a utility. The surveillance data flow is schematically represented in Figure 21.

B. THE ACCS COMMUNICATIONS CONCEPT

The ACCS design concept envisions a highly automated ACCS to conduct modern air warfare. To function effectively and meet response time requirements, such an

¹ The separation described here is strictly at the functional level. The physical entities can be collocated or be at different locations depending on whether bunkers are the preferred sites or mobility is emphasized as part of the survivability features required.

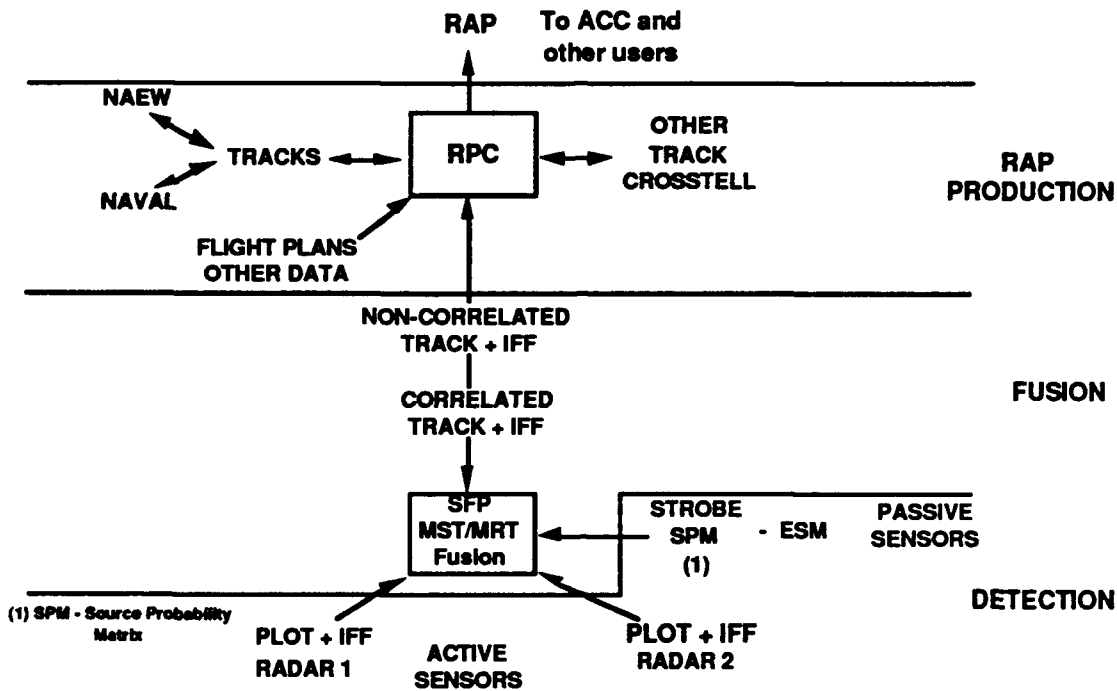

Figure 21. Schematic Representation of RAP Generation In the ACCS

automated ACCS requires high speed, efficient information transfer capability. The information transferred is predominantly digital data (i.e., tracks, and data file transfers). The data traffic is the most important driver in meeting ACCS communications response time requirements such as 5-second maximum update time for the RAP, and is broken into parts, according to the functions supported. The ACCS functions of force management and air space management use primarily variable length, formatted text-type digital messages (referred to as *character-oriented*). The automated data exchange between ACCS entity databases is based on event-driven updates, which are mainly *bit-oriented* file transfers. The ACCS functions of air mission control, air traffic control, and surveillance use primarily bit-oriented information. All these functions require real-time information transfer and updates as follows:

- **Sensor/Air Picture Data** -- This is the data flow associated with reporting air picture information being gathered by active and/or passive sensors. It requires near-real-time transmission for it to be useful for air control. The air track data are refreshed or updated every 5 seconds. The perishability of the data eliminates any guaranteed delivery requirement. The data volume is

UNCLASSIFIED

directly related to the air situation, the reporting technique, tracks or plots, the data message format, and the update rate. The rate of production of data traffic is also dictated by the characteristics of the plot extractors or trackers used at the sensor. In summary, the basic information exchange required to report air picture data is irreducible and dictated by the air situation. Data channels are sized to allow real time reporting of peak air picture activity. In view of the urgent real-time need for air picture data, it presents the most demanding of communications requirements and is unique to ACCS.

- **Airspace and Weapons Control and Coordination Data** -- These data are transferred in bursty, randomly-timed data streams, but with near-real-time transmission requirements owing to the more rapid response times dictated by the high speed of modern air warfare.
- **Planning and Tasking Data** -- These data are sent in data streams of varying length and frequency, depending upon the planning/tasking cycle times desired. The data, in general, do not require a real-time delivery, but do require guaranteed delivery and are sent to multiple addresses.
- **File Transfers, Software Loads, and Data Dumps** -- These consist of bulk transfers of data that are normally not part of the regular operational data traffic load. They require guaranteed, ordered delivery, but reasonable delays can be tolerated.

The ACCS communications system design envisions packet-switched data and digital circuit-switched voice common user systems which interconnect all ACCS entities at Principal Subordinate Command (PSC) level and below. The network is interconnected by cross-border links for inter-regional communications, and has gateways to enable users to access ground-air radio services and establish connectivity with maritime forces (afloat and ashore), army units, and external agencies (e.g., meteorological, air traffic control, and national authorities). Figure 22 illustrates the ACCS communications architecture of interconnected packet and circuit-switched networks.

In general, this fully integrated network providing all communications services (voice, character, and binary data) leads to the lowest overall cost for any given level of survivability required. Common-user switched services are used to satisfy ACCS user requirements. Secure, ECM-resistant ground-air voice and data communications are provided to common standards throughout ACCS for interoperability and flexibility of employment. The radio terminals (transmitters/receivers) will be sited to achieve optimum coverage, deployed in sufficient numbers to achieve gapless coverage, and meet peak mission requirements with sufficient redundancy to permit graceful degradation in wartime.

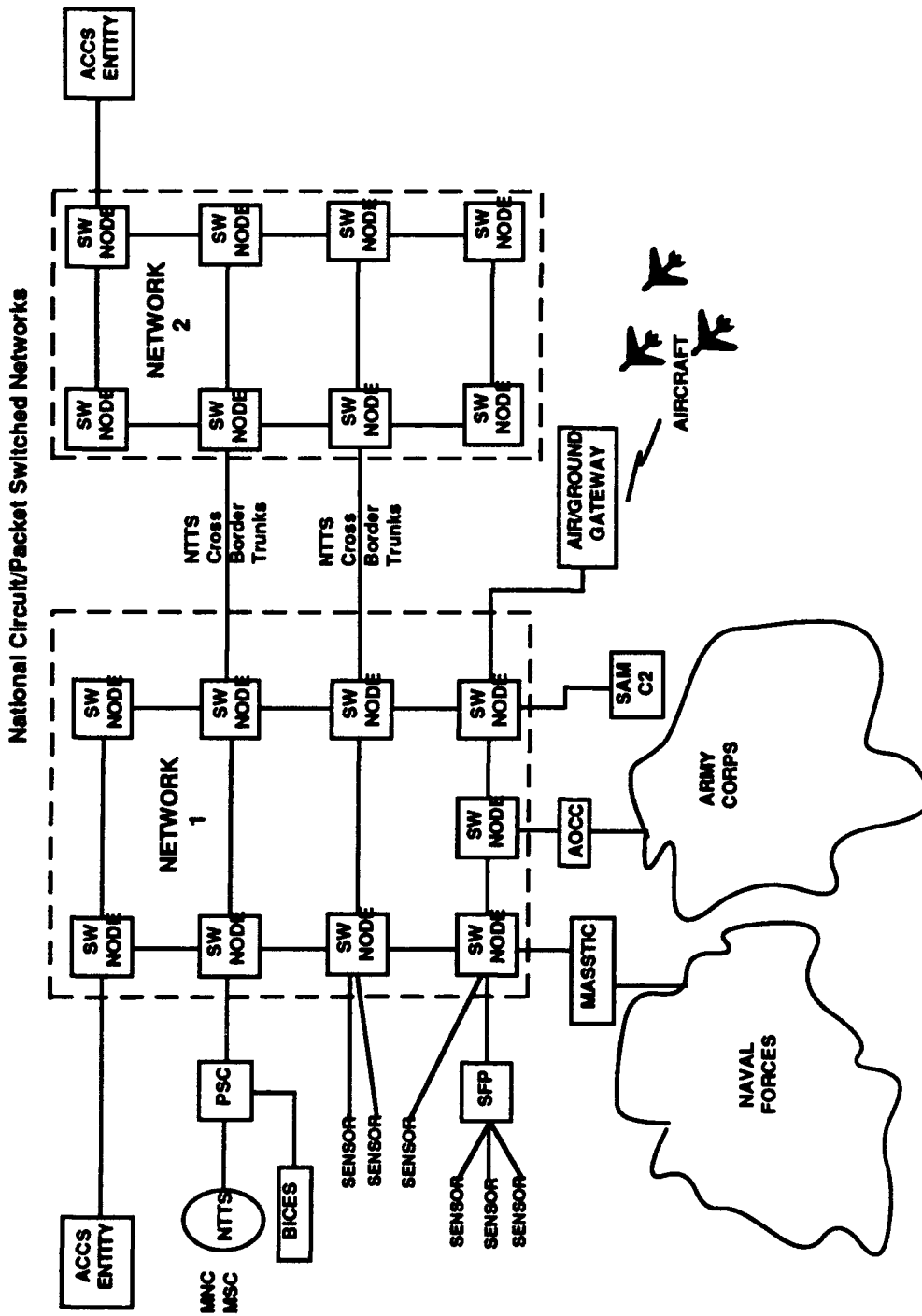

Figure 22. ACCS Communications Architecture

UNCLASSIFIED

The radio terminals will be connected to ground network switch nodes, and are remotely controlled and accessed by users according to operational need. As aircraft transit the airspace, automatic selection and switch-over between radio terminal sites is provided, to maintain an optimum communications link between controllers and aircraft.

The ACCS communications network will replace the current maze of dedicated point-to-point voice, teletype circuits, and Link 1 point-to-point data circuits used throughout ACE for air command and control. The network will consist of:

- A common-user, packet-switched, data system which replaces Link 1 and provides all required digital data transfer requirements including RAP distribution
- A common-user, circuit-switched, digital (64 kbps) voice system
- A number of ground-air-ground radio nodes distributed throughout the region and connected to the common-user communications system, providing all required voice and data interchange from ground ACCS sites with aircraft
- A communications processor located within each ACCS entity to interface the entity to the ACCS communications and the associated ACCS access trunks needed to connect to the common user network.

The communications system infrastructure which provides the transmission capability for ACCS communications consists of:

- A physical transmission plant (e.g., cables, radio relay) that provides the means to transport the communications signals between system nodes. This plant will be derived from NATO/national military communication systems.
- The packet data switches and circuit switches located at each node that respond to signaling information that directs data messages to their destination and connects voice users.

The technical data needed for voice and data information include:

- A standard set of data messages encapsulated into standard packets with standardized routing information, thereby enabling the computer to understand the data message and to set the switches to route these data messages correctly.
- A set of transmission standards that ensures interoperability between systems, and ensures that the data messages are properly entered into and transported through the system.
- A multi-address protocol so that data messages do not have to be transmitted more than once.

UNCLASSIFIED

- Sufficiently fast transit and switching times so that the critical 5-second RAP update requirement is achieved and maintained.
- Common telephone signaling information that enables the circuit switches to interconnect the called and calling parties.
- A common voice encoding standard so that voice circuits can be interconnected.

The ACCS Team (ACCST) determined that the procurement of supporting transmission (i.e., wire, cable, radio relay) systems was not required. Instead, the ACCST proposed the use of transmission capacity that is available on existing and planned national military digital networks, together with NATO-owned cross-border digital transmission capacity. The communications concept is based on the fact that each nation has in progress or is planning new military digital transmission communication systems. Also, NATO is planning to upgrade its cross-border connections to digital grade. Consequently, digital communication transmission systems should be available when ACCS is scheduled to be implemented, but this is not assured. The major difficulties are the availability of funding and agreed-upon digital standards to ensure that communications networks and switching would be interoperable across nations.

The ACCS data communication system requires the development of the following data message sets to carry ACCS information. When collected together, these message sets constitute the ACCS data message catalogue:

- **Bit-Oriented (Binary) Messages** -- used for rapid, accurate, machine-to-machine information transfers such as sensor data, radar plot and track data, RAP dissemination and track/sensor management data. The content and bit structure of the data messages require precise construction and documentation in order to program computers to read and process bit coded data message information. The Allied Data Systems Interoperability Agency (ADSIA) has the task of standardizing these messages for NATO.
- **Character-Oriented (Text) Messages** -- for transfer of text information both free text and formatted text. Information content is transferred by means of alphanumeric characters. Data messages, while man-readable, require precise documentation so that computers can complete formatted messages and present the information for reading. Standardization of this type of data message is also an ADSIA responsibility.
- **Protocol Requirements** -- the unique set of rules by which both types of data messages can be transferred through digital data systems. These are expressed in terms of integrated and/or layered protocols and agreed international

UNCLASSIFIED

standards and require NATO standardization. Responsibility for network transmission technical standards belongs to the Tri-Service Group on Communications-Electronics Equipment (TSGCEE).

- Digital Voice -- CCITT standard PCM 64 kbps for security and clarity.

The ACCS approach to interoperability requires harmony and consistency with overall NATO standardization efforts in the Military Agency for Standardization (MAS), Allied Data Systems Interoperability Agency (ADSIA), and the Tri-Service Group on Communications-electronics (TSGEE) Sub-Group 9 (SG9). Where possible, the ACCS design will utilize the standards developed by these bodies. The procedures used for the development of interoperability standards are specified in the NATO Interoperability Management Plan (NIMP) produced by ADSIA. The NIMP provides an overall strategy to which all bodies involved in work on interoperability of data systems should adhere and recognizes the following three, distinct, complementary sets of interoperability standards:

- **Operational Interoperability Standards:** These standards are written for the most part, but not exclusively, by the MASD and the NATO military commands. They include tactical doctrine and procedures, standard military language (including an operational vocabulary), and specific information exchange plans.
- **Procedural Interoperability Standards:** These standards, for which ADSIA is responsible, specify the form in which information is to be transferred. Currently, there are requirements for two types of procedural standards: character-oriented, and bit-oriented. Character-oriented standards relate to textual messages, and are system independent. Bit-oriented (or data link) standards relate to formatted messages exchanged directly between tactical data systems interconnected through automated data links. These standards, developed for specific data link systems, are system dependent.
- **Technical Interoperability Standards:** These standards are developed by groups subordinate to the NATO Conference of National Armaments Directions, under the overall coordination of TSGEE (SG9). They specify functional, electrical, and physical characteristics of equipment to allow the exchange of information. At the equipment level, many factors need to be considered to ensure interoperability (e.g., modulation techniques, ECCM characteristics, communications security techniques), since incompatibility of any one aspect may deny interoperability.

NATO uses the International Standards Organization (ISO) reference model for Open Systems Interconnection (OSI) as the basis for the development of technical interoperability standards. The NATO-adapted reference model for OSI is briefly described

UNCLASSIFIED

in Annex A of Volume IV, Generic Portion, ACCS Master Plan. While ADSIA is responsible for the procedural standards, the TSGCEE (SG9) is responsible for the OSI technical standards -- i.e., the development of seven-layer standards in the framework of the NATO Interoperability Reference Model. The OSI standards developed by the TSGEE (SG9) are referred to as the Technical Common Interface Standards (TCIS). NATO Common Interface Standards (NCIS) include, in addition to the TCIS, the NATO Procedural Interoperability Standards (NPIS) and the transmission media standards.

Communications aspects are covered by Layers 1 to 4 of the NATO Interoperability Model (STANAG 4250), plus the technical standards for transmission media. Layers 1 to 3 provide for the user access to specified network services (e.g., X.25 packet network protocols), while Layer 4 establishes an end-to-end transport service between users. ADP aspects are covered by Layers 5 to 7 of the NATO Interoperability Model and, for design purposes, are considered to be implemented in the ACCS host ADP systems. The TCIS, although based on ISO and Consultative Committee on International Telegraph and Telephone (CCITT) standards, must be extended to include multihomed and mobile host systems, multiend point connections (multiaddressing), internetworking, and network/system management functions.

In ACCS, there is a multiplicity of functions with a wide variety of interactions between the functions. The functions were grouped within the ACCS entity where they are performed (see Figure 10 in the preceding chapter). The information flow into and out of an ACCS entity constitutes the Information Exchange Requirements (IER). The IERs are then used to determine the digital message formats needed to carry the information. The ACCST has documented the ACCS IER development in detail.²

In the ACCS Master Plan, the required digital messages that carry operational information were defined through examination of military operational requirements, the ACE reporting system, Allied Technical Publications, and similar documentation. These messages were documented in the initial ACCS message catalogue, which includes digital message sets required for sensor-SFP, and SFP-RPC messages.³ The information transfer represented by the information categories defined by these messages derives from the ACCS functional module connectivities.⁴ The initial ACCS message catalogue,

² Volume IV, Overall ACCS Design, Generic Portion, and Supporting Document 5, Quantification of Requirements, to Volume IV.

³ Supporting Document 5, Quantification of Requirements, to Volume IV.

⁴ Supporting Document 4, Structure and Characteristics of Organization, to Volume IV.

UNCLASSIFIED

together with the initial IERs, were used to size the ACCS communications network and switch throughputs.

Sensor message traffic represents a special subset of bit-oriented messages with regular flows of highly perishable plot/track data. The ACCST found that there was no set of NATO or national standard messages for sensor data transfer. The messages that existed were largely generated by the sensor manufacturer, differed greatly, and did not contain bits defining time or time tags. Accordingly, the ACCST researched, defined, and documented⁵ sensor data messages required for sensor-SFP information exchange.

The ACCST wished to avoid long delays in agreeing upon and documenting new message standards; hence existing message standards were used wherever possible. A review of existing data message catalogues revealed that the TADIL J message set provided most of the needed messages. Only minor modifications to provide time tags would be required. Additionally, the message set provided for the variable message text formats required by ACCS for character-oriented messages. Accordingly, the ACCST selected the J-series message set as defined in STANAG 5516 as the basis for the bit-oriented message standard for ACCS. Since the ACCS will be phased in over a long time period, ACCS data communications must also continue to interface with Link 1 and Link 11 data messages during the transition period.

In addition to the digital data communications, ACCS requires a responsive voice circuit-switched communications system. Rapid circuit setups and switch times are required to ensure the tasking, direction, and control of modern aircraft. The voice network is digital at 64 kbps to ensure speaker recognition and security. This requirement for 64 kbps voice channels drives communications network sizing. The ACCS communications sizing data show that a range of one to four 64 kbps channels per entity is sufficient for data but many more channels are required for voice. To meet the different switching and response characteristics of the data and voice, the ACCST proposed two networks: a circuit-switched network for voice and a packet-switched network for data. The packet data network would use transmission capacity within the circuit-switched network. The data circuits would be routed to separate packet switches which would provide the required packet data circuit access and switching. Communications processors would be located within each ACCS entity to terminate both data and voice communications circuits.

⁵ Supporting Document 5, Quantification of Requirements, to Volume IV.

UNCLASSIFIED

In the Central Region, ACCS entities are located in three separate nations. Each nation has its separate national military network. The interconnection of these networks, in order to create a region-wide transmission capability, requires military-owned links across the national borders. These interconnecting links, called Cross-Border Connections (CBC), are provided by NATO for NATO transmission systems such as the NATO Terrestrial Transmission System (NTTS). Nations may also establish CBCs between each other by means of bilateral national agreements.

For interregional communications, ATAF area networks will be interconnected using NATO crossborder transmission bearers to link trunk nodes in adjacent networks. The Maritime Air Operations Centre (MAOC) is used to coordinate air activity with maritime forces afloat and the Air Operations Coordination Centre (AOCC) provides connectivity to army forces. Gateways will be established at link nodes to connect to external agencies. ACCS users at PSC level and above will use the NATO Integrated Communications System (NICS) switched common-user networks, but NICS will not have directly connected users below the PSC level. Traffic between the national and NATO common-user networks will require gateways at the trunk nodes. Ground-air-ground communications will interface with the ground network at the radio sites, through gateways that will be connected as additional network users via access links to trunk nodes.

C. THE GROUND-AIR-GROUND COMMUNICATIONS SUBSYSTEM

The ACCS ground-air-ground communications subsystem responds to the operational need to improve the survivability and flexibility of communications in support of air missions. To provide uninterrupted communications throughout all missions -- offensive, defensive, support, and early warning -- the system must provide a gapless coverage equivalent to the surveillance, even in a jamming environment. Operational requirements of the system require that the ground-based ACCS support voice and data traffic with aircraft, using a variety of secure and jam-resistant transmissions over HF, VHF, UHF, and Multifunctional Information Distribution System (MIDS) radio links. UHF will continue to be the major band used for military air traffic control (ATC). HF will be used with aircraft operating at extended distances such as over water and beyond the Forward Line of Troops (FLOT) when line-of-sight links cannot be used. MIDS will be used for automated data exchange with aircraft equipped with it. VHF in clear voice will be used for civilian ATC communications.

UNCLASSIFIED

The ground-air-ground communications architecture design uses a grid of interconnected primary radio stations, each station being equipped with receivers and transmitters for the various aircraft radio bands and an interface with the ground communications network via gateways. The general organization of the ground-air-ground radio assets and their interfaces with the ground networks is shown in Figure 23. Control agencies can communicate with aircraft by establishing circuit-switched voice channels and packet-switched data channels through the ground network and one of the air-ground gateways, and accessing and remotely controlling radio terminals at any of these stations.

The gateways perform the remote control of the radio terminals, and also serve as interface standard translators. The voice interface may, for example, convert 16 kbps CVSD to 64 kbps PCM voice encodings and perform crypto interfacing in order to interconnect the radio voice circuits with the ground network. For data traffic, interfacing functions may include protocol conversions, data buffering, and data forwarding to end users.

D. THE MARITIME COMMUNICATIONS SUBSYSTEM

A connection between the ACCS and maritime forces is included in the ground network to exchange air picture and to coordinate air operations over the sea areas adjoining ACE. This interface is called the Maritime ACCS Ship and Shore Tactical Interface Component (MASSTIC). The MASSTIC is organized as shown in Figure 24. The chart illustrates how the various components of the MASSTIC, which communicate with ships afloat and with aircraft, are integrated into the ACCS communications network.

The MASSTIC manages all ACCS/maritime tactical data exchanges, and establishes connectivities with maritime data link types. For years to come, Link-11 is expected to operate, using the M-series catalog of messages. Ships which are not provided with a Link-11 terminal will continue to use Link-14 (teletypewriter). In the long-term, an Improved Link-11, which is not yet defined, will appear. MIDS (Link 16) is likely to be introduced extensively in support of maritime operations.

The MASSTIC incorporates and supplements the Ship-Shore-Ship Buffer (SSSB) currently being developed and installed to interface Link 1, Link 11, and Link 14. The effectiveness of the SSSB will be limited, however, since Link 1 is unencrypted. Link 11, which is encrypted, generally will not use the SSSB due to Link 11 security restrictions, but an interface via Link 14 teletype is possible. The MASSTIC eliminates this security problem with bulk encryption.

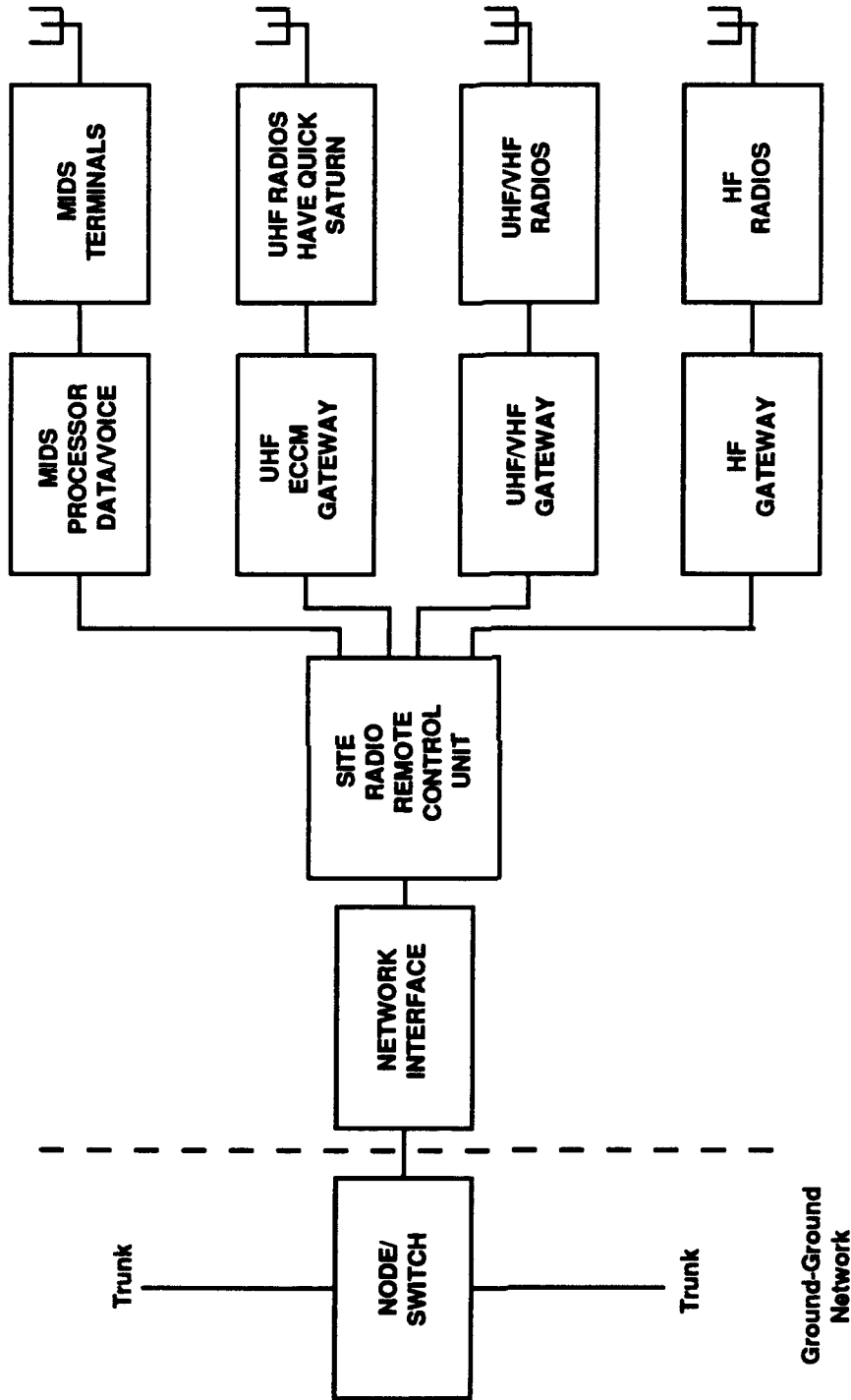

Figure 23. Ground-Air-Ground Communications

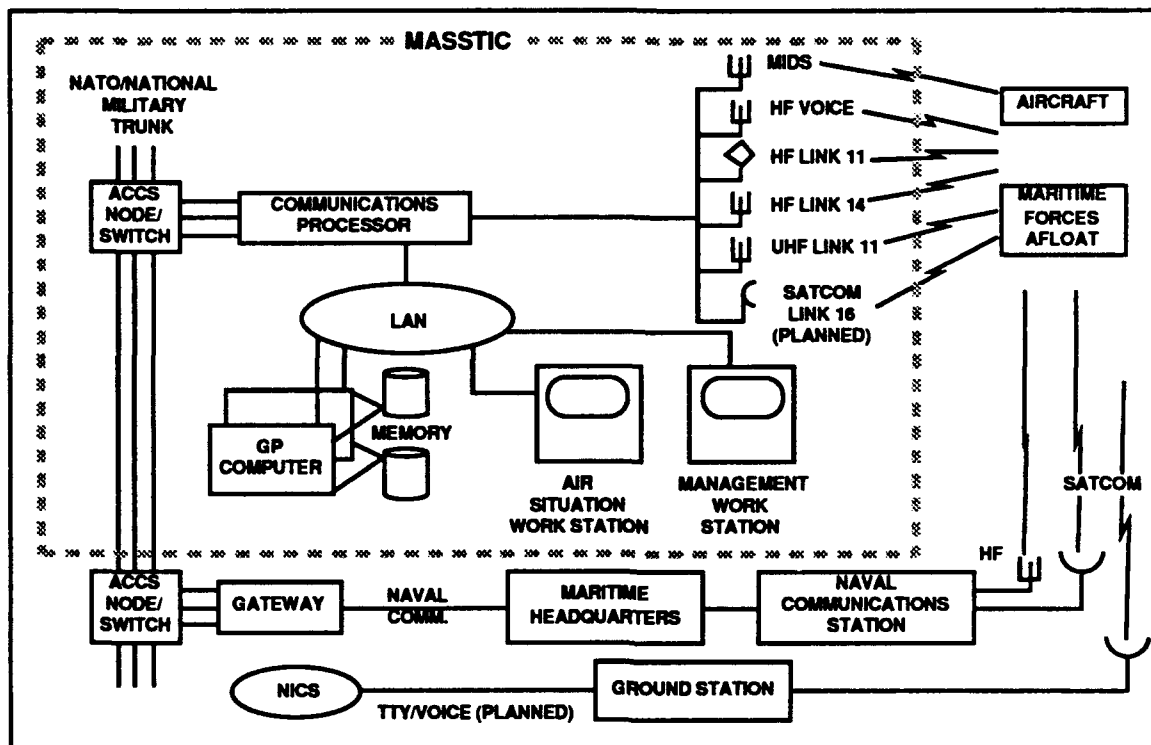

Figure 24. The ACCS Ship-Shore Tactical Interface Component

E. COMMUNICATIONS TRANSITION CONSIDERATIONS ⁶

ACCS communications, as detailed herein and in Volume IV, Generic and Regional Supplements to the ACCS Master Plan, will enable voice and data information to be exchanged among the PSCs and all ACCS entities below the PSC, with interfaces to navy, army, and other related command and control assets. The ACCS data system must, at a minimum, be in place and available when the transition from NADGE to ACCS commences. Voice communications are available from a variety of means. ACCS will evolve its communications system from each area's digital military switched networks. PTT networks will be used as necessary for backup. The NTTs may be used to provide ACCS cross-border connections between area systems. The user site communications facility (communications processors, internal voice distribution systems) and network access links (see Figure 12 in the previous chapter) that terminate and distribute voice and

⁶ The information in this section was extracted (some of it verbatim) from Volume V, ACCS Master Plan, Phase I Transition, Part 2, Section D.

UNCLASSIFIED

data information within each entity are procured as part of the entity. The system must interface with Link 1, which will continue to be used for the existing NADGE sites.

Upon completion of the transition, the ACCS communications system will replace the currently used mix of NATO and national dedicated voice and data circuits. The ACCS common-user, packet-switched data network will absorb Link 1 and most of the present data links used to pass air track data, and will use bit-oriented messages for sensor, RAP, and air operations data. Character-oriented messages will be used over the packet-switched network for text data transfer among the various ACCS entities, replacing the current point-to-point teletype circuits. The bit-oriented message standards are being codified by ADSIA using, as a base, the J-Series message catalogue developed for Link 16. The character-oriented message standards will also be developed by ADSIA.

Technical data transmission standards (layers 1-4 of the 7-layer Open Systems Interconnection model) needed to enable the various national networks to receive and transmit ACCS data messages must be developed by NATO. This standardization effort is normally accomplished by the TSGCEE. The various sensors netted to ACCS plan to use semi-permanently switched circuits to the SFP using standard sensor data messages. The data link transition strategy is detailed in Volume IV, Overall ACCS Design, Generic Portion, and is summarized in Table 14.

ACCS message and transmission standards are essential to begin the transition to the ACCS communications system. Without these standards the ACCS computers and national networks will neither understand nor be able to process ACCS data.

Most NATO countries will modernize their networks by implementing a digital circuit-switched network with a packet-switched overlay, or by an integrated voice and data network. In addition, NATO plans to implement the NTTS to replace the ACE HIGH network. NTTS trunk segments will be superimposed on each nation's communications network and interconnected by NATO-owned or PTT-leased cross-border links. Similarly, ACCS communications will be superimposed on national digital switched networks. It is essential that the nations implementing ACCS entities provide the necessary switched networks and ensure they are available for use when the entities are installed. If these networks are not available, equivalent, dedicated services must be provided as an interim solution. The use of dedicated circuits would, however, become increasingly complex and impractical as the number of ACCS entities and necessary interconnections increases.

UNCLASSIFIED

Table 14. Data Link Transition Strategy

	Baseline	Transition	Long-Term
ACCS Ground Environment Data Links	LINK1 LINK 3 LINK 6 LINK 7 MBDL ATDL-1 LINK 11B (Note 3)	LISA (Note 1) (also supporting mission management, control, status reports, C2RM, and sensors) ATDL-1 (Note 2) LINK 11B	LISA (single multi-functional message catalogue)
ACCS Ground-Air-Ground Data Links	LINK 4 (interim use only) JMS (NAEW) LINK 16 (initial deployment)	JMS LINK 16 (expanded use)	LINK 16
ACCS Maritime Data Links	LINK 10 (Note 4) (interim use only) LINK 11 LINK 14	IMPROVED LINK 11 LINK 14 (for non-LINK 11 ships) LINK 16	LINK 11 REPLACEMENT (to be defined) LINK 16

- Notes:**
1. NATO has entitled this link, which uses the enhanced J-Series message catalogue, "Link in Support of ACCS (LISA)."
 2. ATDL-1 may be necessary for certain direct ACCS interfaces with SAM fire units where no organic SAM control element exists.
 3. NATO has designated TADIL-B as Link 11B.
 4. LINK 10, and certain other national specific data links currently in use, to be phased out.

Data exchange between ACCS and non-ACCS air defense sites will require interfacing. The interface function could be provided two different ways. If no additional capabilities are foreseen at the non-ACCS air defense sites, the interface function will be embedded in the communications processor of the ACCS entity. If the non-ACCS air defense site is required to process and display additional data links provided by the new ACCS system (e.g., RAP information), an interface device needs to be developed separately and implemented at the non-ACCS air defense site for an interim period.

The ACCS communications system and the NTTS will both use capacity from the national digital networks, but in different ways. ACCS uses part of the national network and packet-switched data services to perform ACCS information exchange, partly because ACCS combines NATO and national air operations. NTTS, however, uses national network capacity to: (1) provide permanently switched 2 Mbps trunks to link voice and message switches, and (2) provide permanently switched 2 Mbps trunks and 64 kbps circuits for dedicated end-to-end connections for qualified NATO users. Because of these

UNCLASSIFIED

differences, whether the NTTs will be able to provide ACCS communications and become the bearer system, or even provide the cross-border connections, is unclear and needs to be clarified. ACCS requirements for digital data channels (64 kbps) and associated implementation schedules should be closely coordinated and documented between NACMA, SHAPE, NACISA, and the nations. The ACCS Volume I Regional Supplements detail the requirements. The current air defense and air support circuits (e.g., Link 1), which will be subsumed by ACCS communications as they are phased in, also need to be identified.

The following ACCS communications actions are needed to accomplish the ACCS transition:

- Communications devices associated with each ACCS entity, such as user site communications facilities, bulk and end-to-end encryption and access links, will be provided as part of the installation package for each entity
- The nations hosting ACCS entities should ensure that circuit and packet switches and trunk and circuit groups for communications supporting entities are available
- Interfaces to facilitate communications, both with other systems and between entities and old air defense sites, must be provided.

The ground-based ACCS must support voice and data communications with aircraft that will use a variety of secure and ECM-resistant radios in the UHF, HF, and D bands (MIDS/LJMS). UHF radio with ECCM (e.g., HAVE QUICK, SATURN) will provide the primary ground-air-ground voice communications for the foreseeable future. HF will be used where required for long distance aircraft operations. Multifunctional Information Distribution System (MIDS) terminals will be deployed to support secure, jam-resistant data communications with aircraft (initially AEW, but later, advanced interceptors and other aircraft as they are equipped with MIDS). VHF radio will be retained for use with civil aircraft and to provide for the VHF guard frequency.

Ground-air-ground (G-A-G) communications will be an integral part of the ACCS communications system. As new ECCM radios are introduced into aircraft, the same capability must be simultaneously introduced into the ground environment. The ACCS G-A-G communications design envisions a network of G-A-G stations in each region with common-user access via the area ACCS communications system. A standard G-A-G site would consist of remotely controlled devices. Currently, G-A-G communications are usually dedicated to a particular site (e.g., CRC, radar), thus severely limiting its availability for other users. The transition from the present dedicated radio concept to the ACCS network of G-A-G stations, as detailed in Volume IV, Generic, in most cases will occur after Phase I, as it is not provided for in Phase I transition planning.

III. BASELINE SYSTEMS FOR GROUND-GROUND COMMUNICATIONS

Ground area communications which are candidates for the support of ACCS in the Central Region and 5ATAF include the present and future national military communications systems of the individual countries, tactical systems in the Central Region (as "tails" only), commercial PTT systems in the individual countries (as backup only), and the present and future NATO-owned systems. The latter include the present NATO Integrated Communications System (NICS) and the future NATO Terrestrial Transmission System (NTTS). This chapter discusses both the NATO-owned systems and the national systems, which will supply the majority of communications transmission for ACCS.

A. NATO-OWNED COMMUNICATIONS SYSTEMS

1. The NATO Integrated Communications System (NICS)

The NICS presently supports communications requirements for NATO users. This includes air command and control elements at and above PSC level. The NICS also provides switched voice, telegraph service, and point-to-point circuits to certain NATO Air Defense Ground Environment (NADGE) sites. In the future, NICS will continue to support air command and control operations at and above PSC level. The NICS capabilities are severely limited in terms of overall capacity, connectivity, speed of response, interoperability with other systems, and wartime survivability.

The NICS is a circuit-switched voice and a store-and-forward message system, with both ground and space segments. The system connects NATO headquarters, major NATO commands, and civil wartime agencies. The NICS also provides interoperability via gateways with the U.S. Defense Communications System (DCS). Major elements of the NICS include:

- Initial Voice Switched Network (IVSN) -- This network consists of 24 analog access switches, associated interswitch access trunks, and access circuits. The switches are located at principal NATO headquarters and user concentrations; 19 are located in ACE, three in ACLANT, and two in ACCHAN. Final

UNCLASSIFIED

network acceptance occurred in 1984. The IVSN provides narrowband circuit-switched services and serves or plans to serve:

- Direct NICS Subscribers (DNS)
- Indirect NICS Subscribers (INS)
- DNS Secure ELCROVOX (CCU-1)
- INS Secure ELCROVOX (CCU-3)
- Secure Terminal Unit II (STU-II) and SPENDEX-40
- Hot Lines
- Status, Control Alerting and Reporting System (SCARS)
- Secure Facsimile

The IVSN networks will, upon completion of planned expansions, serve approximately 2500 DNS to whom special service features will be regularly available, and 8000 INS who will gain access to IVSN via PABXs or switchboards. Some circuit-switched data circuits up to 2400 bps can be supported by IVSN. Once a circuit has been set up by IVSN (e.g., a telephone call) then any protocol (within bandwidth limitations) can be run over the circuit since it is then equivalent to a point-to-point circuit.

- Telegraph Automatic Relay Equipment (TARE) -- The TARE is a NATO-owned, store-and-forward message switching system, consisting of 18 switches together with inter-TARE trunks and access circuits. Thirteen TARE switches are located in ACE, three in ACLANT, and two in ACCHAN. The network services 450 low-speed and 30 medium-speed users. There are about 30 low-speed and 15 medium-speed gateways to national networks. Switch nodes write messages by predetermined routing codes or by automatic alternative writing using interswitch write status. Node access is either synchronous at 600, 1200, or 2400 bps, or asynchronous at speeds to 300 bps. The protocol is ACP-127 and ITA No. 2, or NATO seven-bit codes. Due to the use of off-line storage, interactive protocols cannot be supported. Both IVSN and TARE use analog techniques and cannot be supported past the 1998-2000 time frame. However, no new NATO switched networks have been planned.

In addition to IVSN and TARE, NICS includes a narrowband secure voice network overlay to the IVSN, the NATO III SATCOM subsystem, terrestrial transmission systems, and the Systems Integration Project.

2. The NATO Terrestrial Transmission System (NTTS)

The NATO-owned terrestrial transmission facilities consist of the ACE HIGH system, which stretches from Norway to Turkey, the Communications Improvement

UNCLASSIFIED

Program 67 (CIP-67), and Satellite Communications (SATCOM). These, together with commercial Postal, Telegraph and Telephone (PTT), provide the source of transmission capacity for IVSN and TARE. The aging, analog ACE HIGH system is planned to be replaced by the NATO Terrestrial Transmission System (NTTS). The NTTS will be digital and, where possible, will use the capacity available on national military systems, such as the Netherlands Armed Forces Integrated Network (NAFIN) and the Belgium Military Communications (BEMILCOM) network. Generally, facilities for cross-border connections will be implemented by NATO, but national systems will also be used, if available. Thus, NTTS will have the capability to provide the cross-border links necessary for interconnection of the separate national systems of the CR host nations, as well as for interconnections with other regions. However, to meet ACCS requirements for wartime survivability, NTTS cross-border links will probably require further augmentation. The planned NTTS network topology, showing cross-border connections (CBC) between the countries, is presented in Figure 25. Although the planned national networks of each country are not shown in this diagram, the dates those networks are expected to be available for NTTS use are indicated, as well as the dates the CBCs are expected to be installed. The probable terminus of each end of each CBC is indicated by an abbreviation of the town name or, in a few cases, "TBD" (to be determined).

3. The CIP-67 Network

CIP-67 is an analog, line-of-sight radio grid transmission network installed in the CR to improve and expand the microwave communications services for AFCENT and its subordinate headquarters. The grid configuration is comprised of a main, hardened, backbone system in the west and a reconfigurable system, using transportable line-of-sight radio stations, in the east. Alternate routes are provided in the event that the primary route is destroyed, fails, or is subjected to traffic overload. CIP-67 provides interswitch links for the NICS IVSN and TARE switches within the Central Region. Interface facilities are provided with other transmission systems, such as ACE HIGH, SATCOM, the PTTs, the national military systems and facilities of the Netherlands, Belgium, Germany, the United Kingdom (STARRNET), the United States, and Canada. CIP-67 is planned to remain in service throughout the 1990s, but since it is an analog system its use for ACCS appears limited.

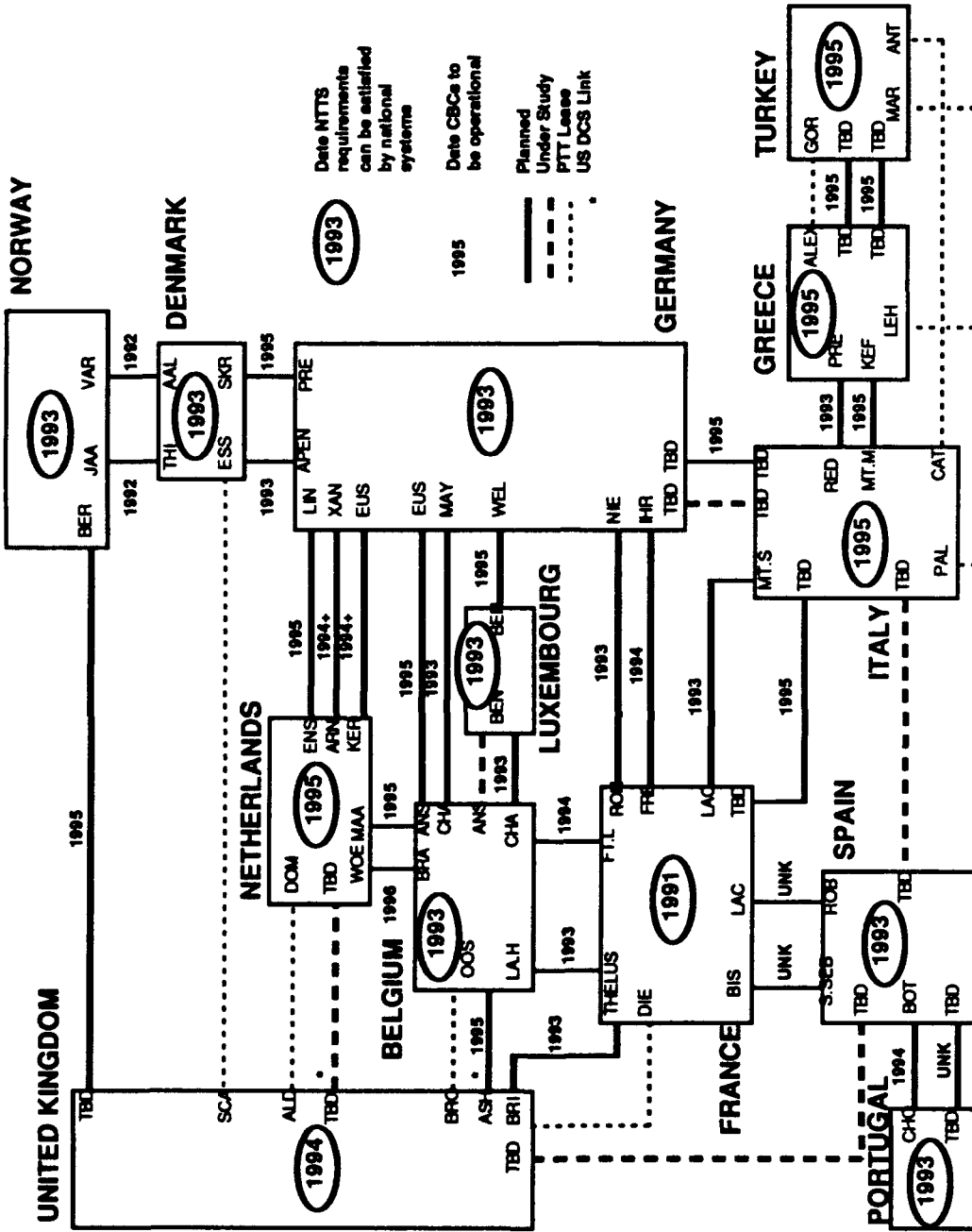

Figure 25. Planned NTTS Network Topology

UNCLASSIFIED

B. NATIONAL COMMUNICATIONS SYSTEMS IN THE CENTRAL REGION

1. Introduction

The Central Region (CR) is unique among the various NATO regions in that it incorporates multiple nations (Belgium, Germany, and the Netherlands). Each of these has its own national military and civilian communications systems. Overlaying these systems are NATO communication systems that thread through the region. The ACCS is designed to provide an integrated command and control system throughout the region irrespective of national boundaries. The communications system designed to support ACCS consequently must be an integrated, unified, single region-wide communications system.

Each nation within the CR has its own well-developed Postal, Telegraph, and Telephone (PTT) public telecommunications with modern voice and data transmission systems. The National PTTs are interconnected through international gateways. Each national military and NATO has well-developed, modern communication systems and all are planning improvements. As a result, the Central Region is rich in communications capabilities. However, with the exception of NATO networks and the DCS, the communications networks are not designed and operated to serve region-wide needs because of their predominantly national orientation.

An anomaly peculiar to the CR is the overlap of boundaries between the Central Region and the Baltic Approaches (BALTAP). The COMTWOATAF boundary with AIR BALTAP is the German-Danish border. The boundary between COMNORTHAG and COMBALTAP is the Elbe River. This overlap of air and ground responsibilities will require careful communications planning to ensure adequate responsive information flow to the proper commands.

The ACCS communications system will derive its primary ground transmission capacity from military communications systems. The national civilian systems (PTTs) are used for back-up capacity. Where needed, the system will make maximum use of the military communications systems maintained by the national forces stationed in Germany, i.e., the United Kingdom, the United States, and Canada.

The prevailing planning approach of the various nations is to develop integrated military communications systems instead of individual systems for each military service. The nations collectively propose to combine their internal military communications and participate in the development of rationalized, cost-effective, integrated communication systems that can meet all military requirements. With this approach, the individual military

UNCLASSIFIED

communications systems within a nation are expected to disappear in the long term. Baseline ground-to-ground communications systems already existing or under implementation which are relevant to the support of ACCS communications are described below.

2. The German Air Force Automated Communications System (GAFACS)

GAFACS is interconnected with the national military networks of Belgium and the Netherlands (BEMILCOM and the future NAFIN, respectively). It is considered to be the prime German component of the region-wide ground-ground network required to meet ACCS communications requirements in the near term. GAFACS has been conceived as a unified command and control communications network for the support of the tactical operational mission of the German Air Force (GAF). The network is presently in the implementation phase and it is planned to achieve final operational capability in 1992. The system is planned as an automatic, digital, circuit-switched network with digital switching and a combination of digital and analog trunk transmission facilities. It will provide voice, data, telegraph, and facsimile services to its users. The network interswitch signalling uses the ITT System 12 standard and the numbering system is based on STANAGs 5042 and 4214. Subscriber features include "off-hook" and user-initiated "hot-line" service and precedence calling provided through user dialing or on a pre-programmed basis. Interswitch trunks are provided primarily by a line-of-sight radio relay network owned by the German Air Force using the 5 GHz band. Radio relay interconnects all 36 switching nodes of the planned GAFACS network, providing fully digital transmission trunks.

Voice transmission is based on the 30-channel CCITT digital transmission standard. The radio relay links will also be augmented by digital fiber-optic cable connections at certain locations. The radio relay trunk transmission system is laid out in a ladder-like structure, consisting of two main north-south routes in the western part of the FRG. Several lateral interconnections are provided between the two main routes, and additional extensions are provided to the east, connecting switching nodes and user access facilities. The initial design capacity of the radio relay trunks is 240 channels of 64 kbps, provided by two multiplexed 8 Mbps groups. Digital groups will be two Mbps, bulk-encrypted. User sites not collocated with the trunk network nodes or other transmission facilities will be also connected mainly by digital line-of-sight radio access links to the network. The layout of the GAFACS system is shown in Figure 26.

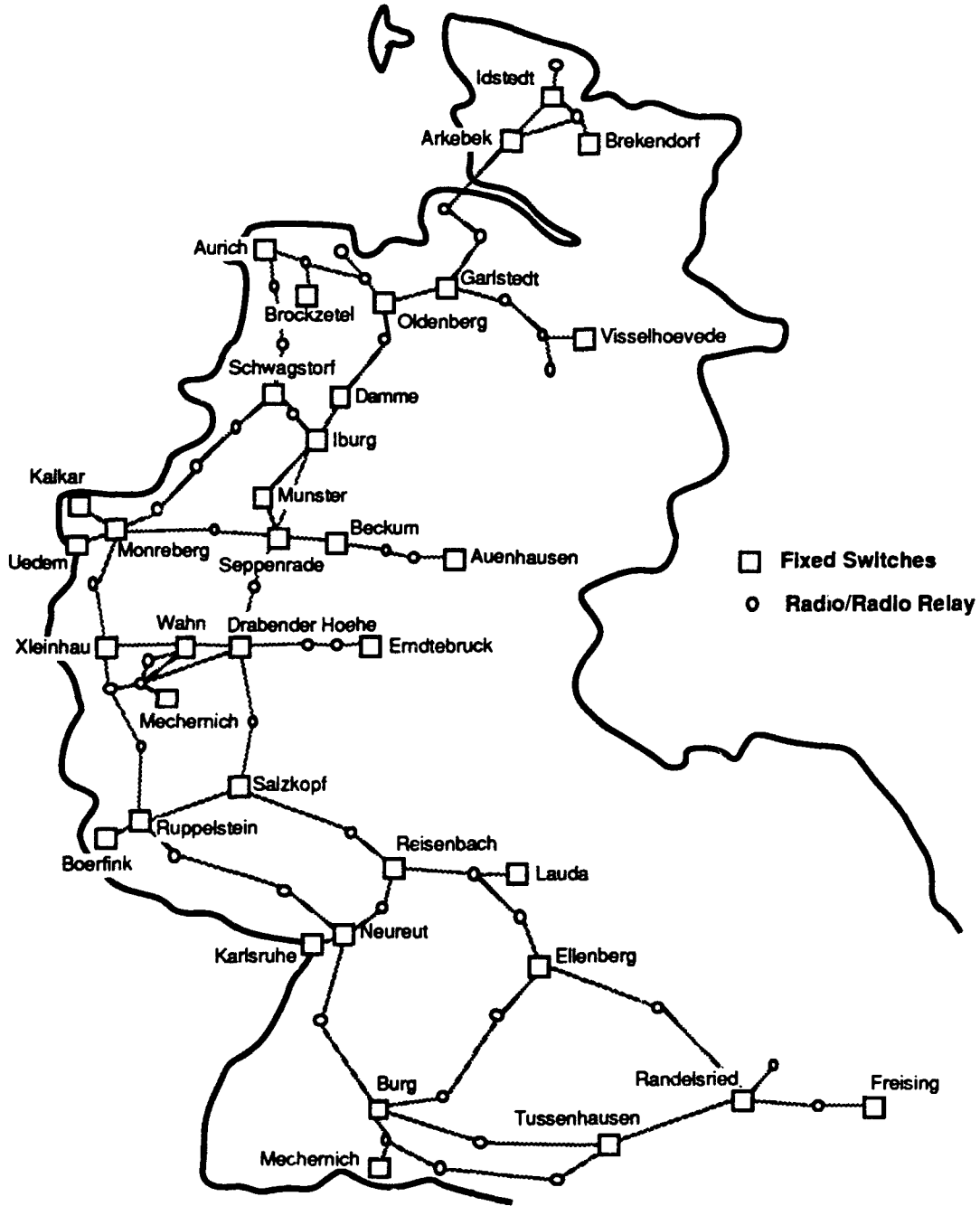

Figure 26. GAFACS Network with Military (LOS Radio) Trunk Connectivity

3. The German Federal Armed Forces Integrated Services Digital Network (FAF ISDN)

In the longer term, Germany plans to integrate its digitalized Federal Armed Forces Strategic Communications System and the tactical communications systems (including GAFACS) of its individual military services. The new system, called the German Federal Armed Forces Integrated Services Digital Network (FAF ISDN), will be based primarily on a fiber optic cable system to be built by the German PTT and employing military-owned switches. This core network will be further interlinked via gateways to the public ISDN of the German PTT. The technology of the FAF ISDN will follow the European standards for ISDN as far as possible. The network will have a basic channel rate of 64 kbps with trunk switching at the 2 Mbps level, and will use CCITT Common Channel Signalling System No. 7. Thus, FAF ISDN will be interoperable with other national military systems in the Central Region, such as the Belgian BEMILCOM network and the NAFIN system of the Netherlands. Installation of over 100 digital trunk switches and around 200 digital local exchanges is already underway. By the year 1999, FAF ISDN will have integrated GAFACS and the German Fleet Command Tactical Radio Relay System. The German PTT expects to have converted all trunk exchanges in its network to digital technology by the year 2003, and all local exchanges by 2020. The layout of the FAF ISDN is shown in Figure 27.

4. The Belgian Military Communications (BEMILCOM) Network

The BEMILCOM network is proposed as the Belgian component of the Central Region ground-ground area network supporting ACCS. It is presently being implemented to provide the Belgian armed forces (air, land, and naval), the Gendarmerie, and some governmental services with a national military telephone, telegraph, and data communications network. The system is fundamentally a static, circuit-switched digital meshed network for both voice and data transmissions comprising up to six time-division multiplex (TDM) transit switching centers. The network provides a large alternate routing capability with precedence and signaling facilities. The implementation of packet-switched data transmission capability for the network has also been considered (BEMILDAT), but no firm plans are available at this time. The complete network will consist of a large number (about 200) of fixed, EMP-protected sites throughout Belgium. Most of these sites will be interconnected by radio relay links, operating in the 2 and 15 GHz frequency bands, and by analog or coaxial cable. Trunk transmission will be based on digital, 64 kbps channels, complying with CCIR and CCITT EUROCOM standards. The CCITT #7 signalling system will be used. The topology of BEMILCOM is shown in Figure 28.

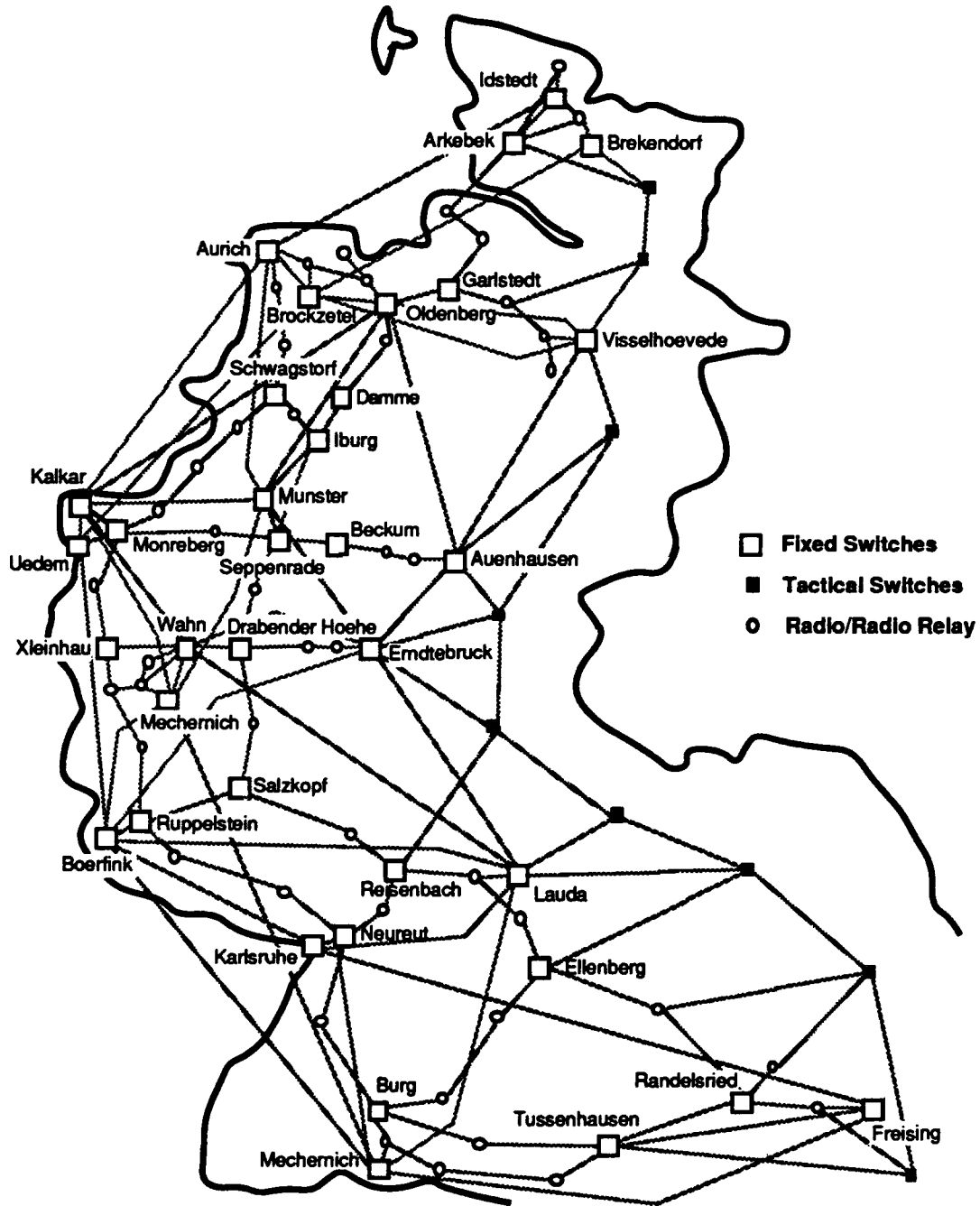

Figure 27. FAF ISDN Communications System

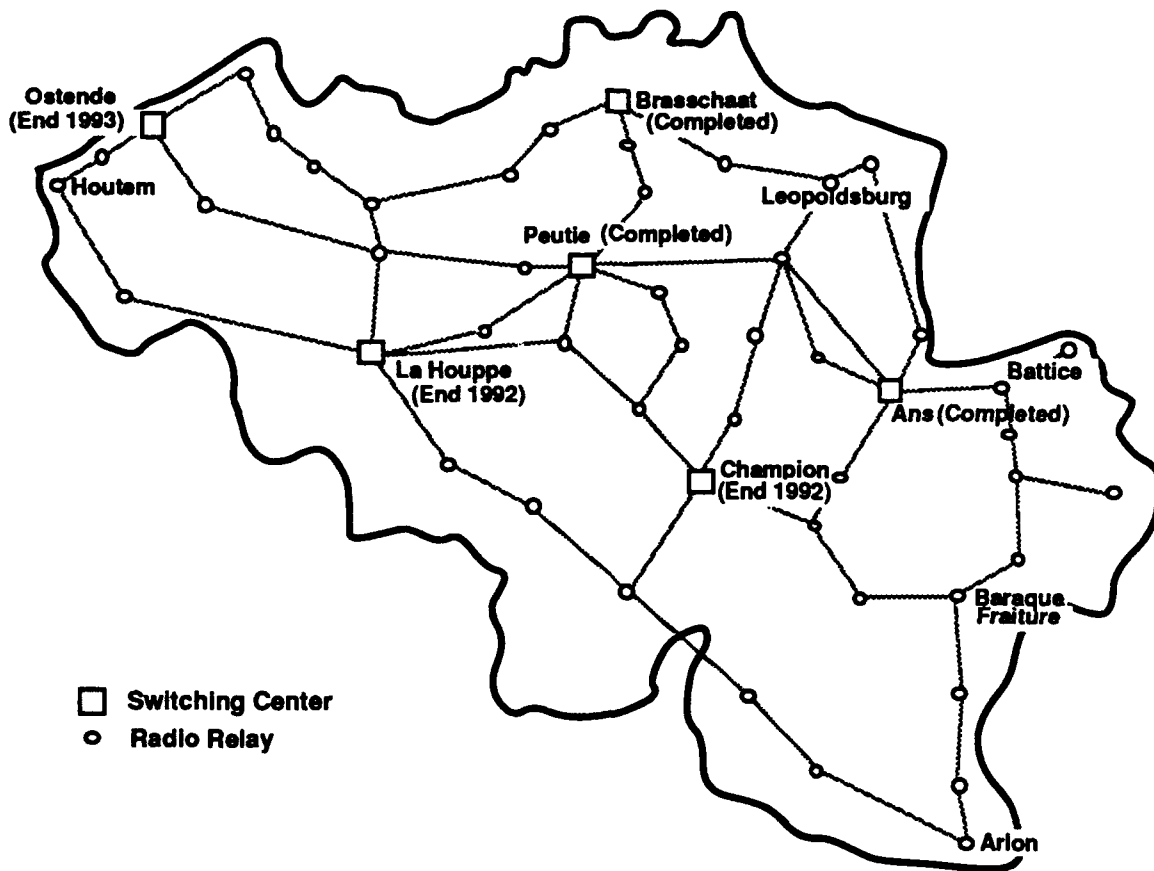

Figure 28. BEMILCOM Network

The BEMILCOM system will be interconnected with the static infrastructure network of the Belgian forces in Germany; the Belgian/French tactical area communication networks (RITA); NICS and CIP-67. Nodes of the BEMILCOM and the NICS could be interconnected by a restricted number of trunks through the CIP-67 infrastructure in Belgium. BEMILCOM is not planned to be interconnected with the PTT. BEMILCOM is planned to be implemented in three phases: Phase I (northeast Belgium, including three transit switches, already completed) Phase II (southern Belgium along the French border, including two transit switches, by the end of 1992); and Phase III (central and western Belgium, including the last transit switch, by the end of 1993).

UNCLASSIFIED

5. The Netherlands Automatic Switched Communications Network (ASCON)

ASCON is the existing circuit-switched telephone network of the Royal Netherlands Air Force (RNLA). Since ASCON is planned to be replaced with the Netherlands Armed Forces Integrated Communications Network (NAFIN) during the mid-1990s, its use for meeting longer-term ACCS requirements in the Netherlands is limited. ASCON presently supports RNLA organizational elements and operational, major administrative, and logistical elements of the Royal Netherlands Army (RNLA) on Netherlands territory.

User access is provided to the ASCON nodes by digital line-of-sight links (the same equipment as used for internodal links) or by military cable connections. Major user locations have dual access, i.e., an active and passive (back-up) access link, while other locations have either a by-pass capability or single access. The network is operated unmanned, except for a primary and a secondary system control center.

The ASCON system consists of 10 TDM switching nodes interconnected by digital line-of-sight (LOS) links. It uses North American standards, with a basic capacity of 4 digital 24-channel groups (56 kbps per channel, plus 8 kbps signaling), of which 2 groups are typically used on each internodal link. A further growth potential to eight digital groups per link is possible. A blocking probability of less than 0.1% is maintained on internodal links. The CCITT North American digital standard used by ASCON makes it difficult, but not impossible, to interface this network with GAFACS and BEMILCOM (which use European CCITT standards) for a fully effective regional network. The network configuration of ASCON is shown in Figure 29.

6. The Netherlands Armed Forces Integrated Network (NAFIN)

NAFIN is presently being planned to replace the existing ASCON and a number of other strategic communications systems presently operating in the Netherlands by 1996. Although NAFIN is a future system, it is firmly planned, and from the standpoint of the ACCS communications design for the Central Region, it can be considered a baseline system.

NAFIN will be a digital, circuit-switched, ISDN-type network with packet-switched overlay for data transmission. The network will fully comply with CCITT (Europe) I-series standards, using a 64 kbps channel structure. The network is planned to contain about 20 circuit switching nodes interconnected by 2 Mbps trunks using a mixture

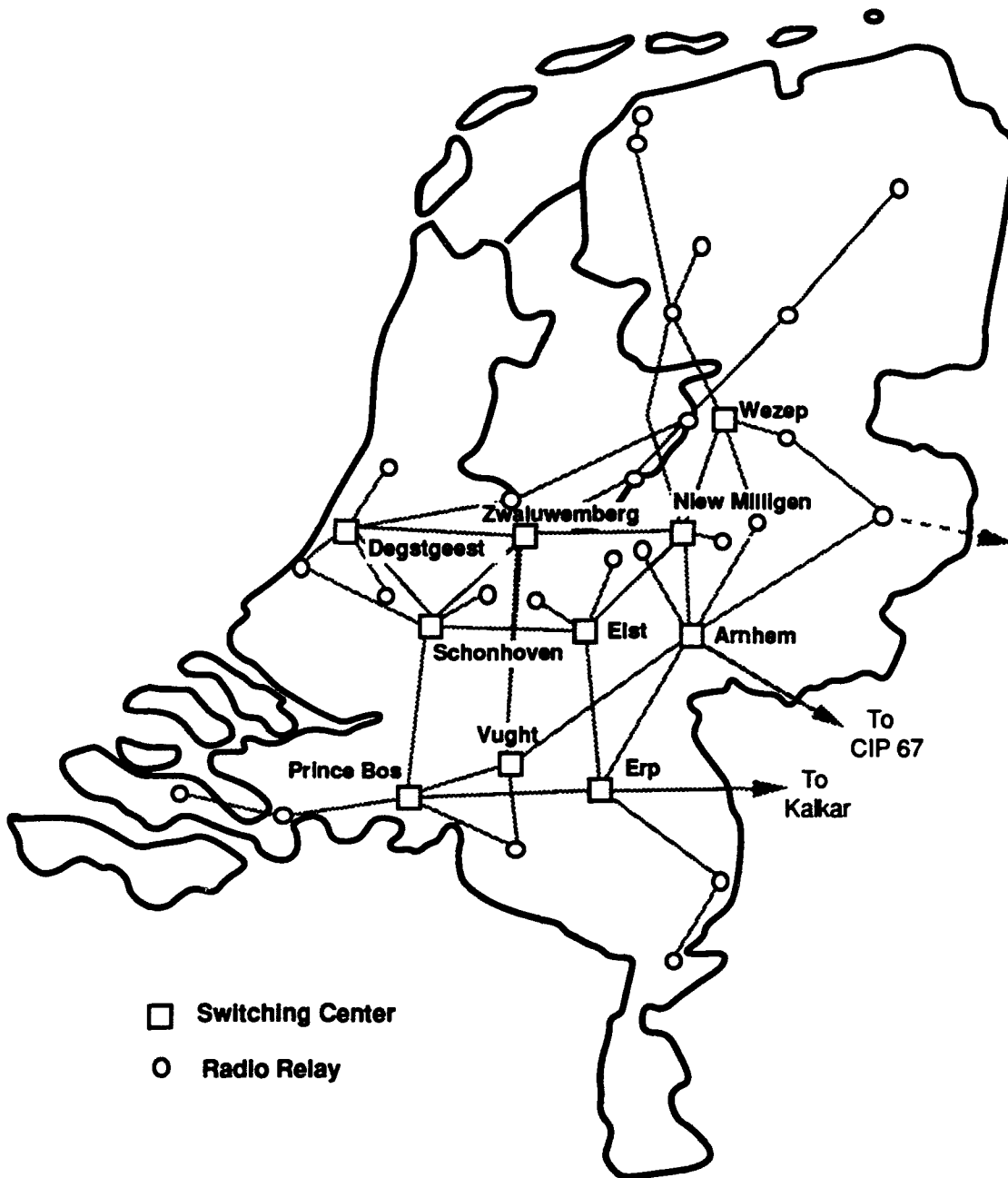
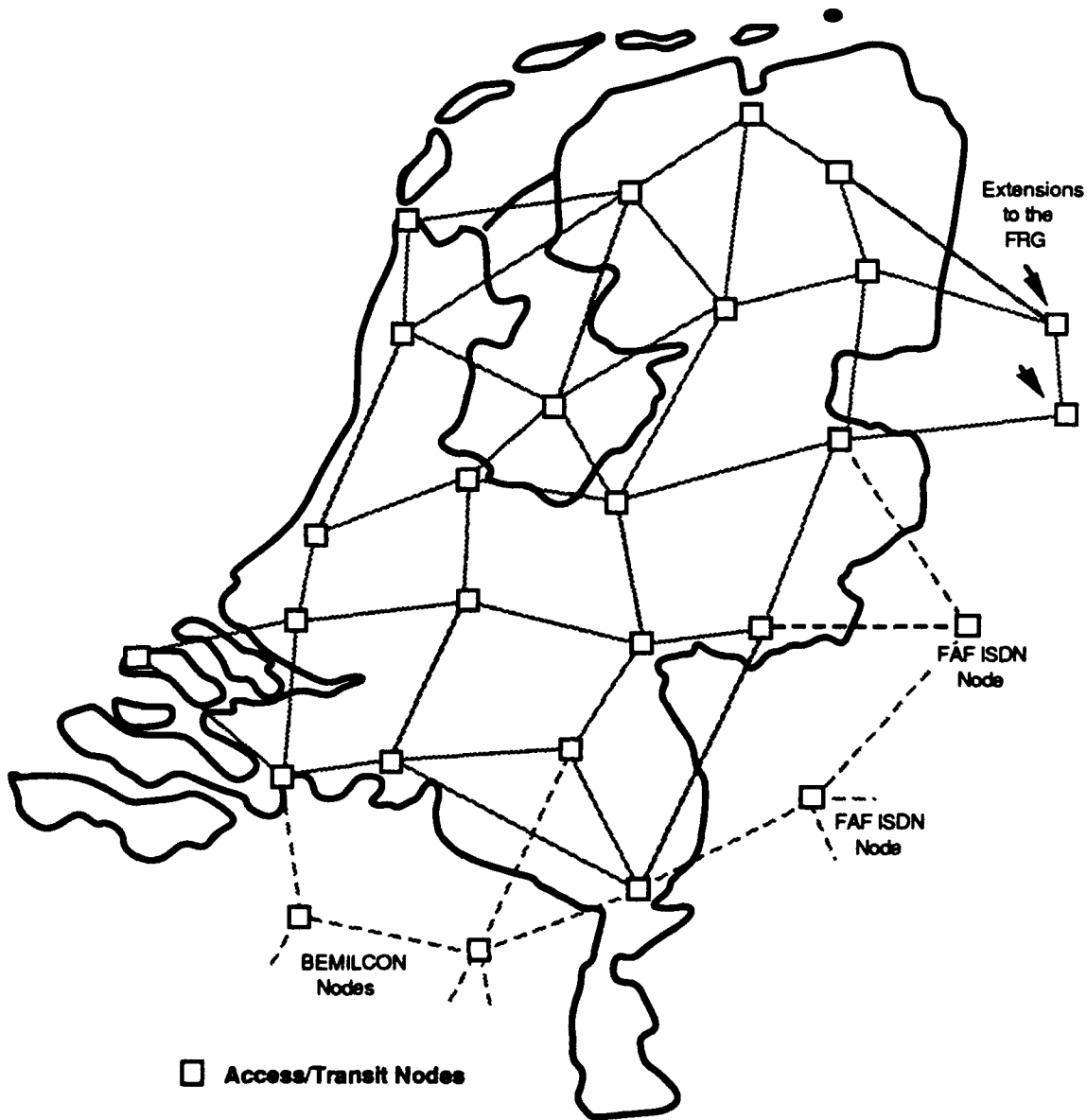

Figure 29. ASCON Communications System

UNCLASSIFIED

of military microwave links and the Netherlands PTT fiber optic cables. This will provide a good coverage of the country for connecting air force (including ACCS entities) as well as navy and army users. Two of the network nodes are planned to be located in the rear combat zone of the FRG for connectivity with the Netherlands army tactical networks. The connectivity and node architecture are depicted in Figure 30.



**Figure 30. NAFIN Communications System
(Conceptual Topology)**

UNCLASSIFIED

C. NATIONAL COMMUNICATIONS SYSTEMS IN 5ATAF

1. Introduction

The Southern region of NATO differs greatly from the Central Region. Each ATAF covers a wholly national area: 5ATAF in Italy, 6ATAF in Turkey, and the Hellenic Air Force (7ATAF when under SACEUR's command in time of war) in Greece. The area is not as industrialized and in general lacks the rich varied communication resources, both

civilian and military, common to the Central Region. Lastly, the individual nations are separated by large bodies of water, making maritime force integration into ACCS much more important.

Because the geography of the area, including Italy, is mainly mountainous with narrow coastal plains, the use of radio relay requires multihop paths with numerous repeaters. There is some use of troposcatter. Ground cable installations in the rugged terrain are expensive. Undersea cable is used extensively for links with other nations. The Italian PTT remains predominantly analog with limited digital transmission capability, particularly in southern Italy. Both the PTT and the military are commencing long-term conversions to digital transmission and switching, but owing to funding difficulties the work is proceeding slowly.

The automation required for all levels of ACCS requires digital communication techniques to achieve the necessary data flows and response times. The communications systems and procedures for ACCS must be standardized between the Central Region and 5ATAF to achieve the interoperability needed for mutual support. A significant number of ACCS entities are planned to be mobile or transportable in 5ATAF. These will require support from, and access to, a static area network composed of NATO, national military, and civilian (PTT) digital transmission facilities. As a result, the pace of ACCS implementation in 5ATAF will be dictated by the progress in modernization and digitalization of the current analog transmission networks.

2. Italian Baseline Communications

a. NATO Project 114F

This is an analog network using UHF/SHF LOS transmission. The system has a capacity of 300 voice channels, interconnects NATO headquarters, Italian Army corps, and

UNCLASSIFIED

relevant strike airfields, and provides pick-up points for mobile elements. No modern expansion or modernization is planned.

b. NATO Project 305

This is a digital LOS point-to-point system between 5ATAF War HQ (WESTSTAR) and maritime headquarters at Proto using military and PTT transmission. There are 30 PCM channels with no spare capacity.

c. Italian PTT

PTT-Italy provides an extensive network of switches and transmission media for voice and data services. There are planned programs for improved services and the evolution of bearer systems to provide digital voice channels, 2 Mbps data channels, and packet data switching.

d. Italian Tri-Service Network (ITSN)

The Italian Tri-Service Network is an analog transmission network which accommodates the defense telecommunication services of major national users (e.g., Italian General Staff, Army, Navy, Air Force). The network is planned to be fully digitalized by the end of the 1990s, and will then be called the Digital Italian Tri-Service Network (DITSN). Army and Air Force segments of the current network will be incorporated into the whole, so that the final ITSN will be a defense-wide system, rather than the current mixture of national defense and individual service segments.

The present analog gridded network comprises 31 nodal stations and 56 trunk-to-trunk stations with access capabilities. The DITSN will have the same configuration as the analog network. However, to enhance survivability, some transportable, sheltered stations will be added. These transportable stations will be capable of performing like a nodal or a terminal station. The DITSN will be based on digital off-the-shelf LOS microwave technology except for one link (Sardinia - Sicily), which will be troposcatter or fiber optics.

The capacity of the present analog network is 960 channels, except over the Italy - Sardinia link (300 channels) and Sardinia - Sicily forward scatter link (120 channels). The capacity of the digital network is planned to be 70 Mbps on the main routes, and 34, 17, 8 and 2 Mbps over secondary routes, or access links. The ultimate goal is a modern transmission network conforming to European CCITT transmission standards and capable of supporting an ISDN.

UNCLASSIFIED

The network will be digitalized in phases, beginning in the north. Figure 31 shows the first phase, which consists of new digital links scheduled for completion in 1991. After the new digital links are completed, the older analog links to the south will gradually be digitalized. This second phase of digitalization will include a north-south digital backbone during the period 1993-1995. The final configuration for the DITSN, which is scheduled for completion by the end of 1999, is shown in Figure 32.

D. THE DEFENSE COMMUNICATIONS SYSTEM (DCS)

The U.S. Defense Communications System (DCS) in Europe comprises transmission facilities, common-user switched voice and data networks, a secure voice system, and other capabilities. The DCS transmission facilities in Europe include military-owned analog and digital line-of-sight microwave and tropospheric scatter radio systems, communications satellites and associated satellite ground terminals, and leased commercial (PTT) circuits. Some DCS transmission capacity is derived from transmission exchanges with NATO and host nations. A substantial portion of European DCS transmission facilities has been upgraded to digital LOS operations to form the Digital European Backbone (DEB). Further upgrades and expansion projects are planned. Portions of the DEB/DCS have already been offered to NATO to provide transmission for the NTTS on a quid pro quo basis. With the expected drawdown of U.S. forces in Europe, it is possible that some portions of the DEB/DCS could be made available to support ACCS transmission requirements.

E. COMPARISON OF NATIONAL MILITARY COMMUNICATIONS NETWORKS

Table 15, below, compares some of the basic transmission (multiplexing) and signalling standards of the national military communications networks discussed in this chapter, and shows the approximate dates that each system is scheduled to reach Initial Operational Capability (IOC) and Final Operational Capability (FOC). The newer systems (FAF ISDN, BEMILCOM, NAFIN, and DITSN) will be interoperable at these levels, while the older systems (GAFACS, ASCON, and the DCS) will not be interoperable with the newer ones without the use of gateways. The GAFACS signalling system (ITT System 12), for instance, differs from all the other systems in the region.

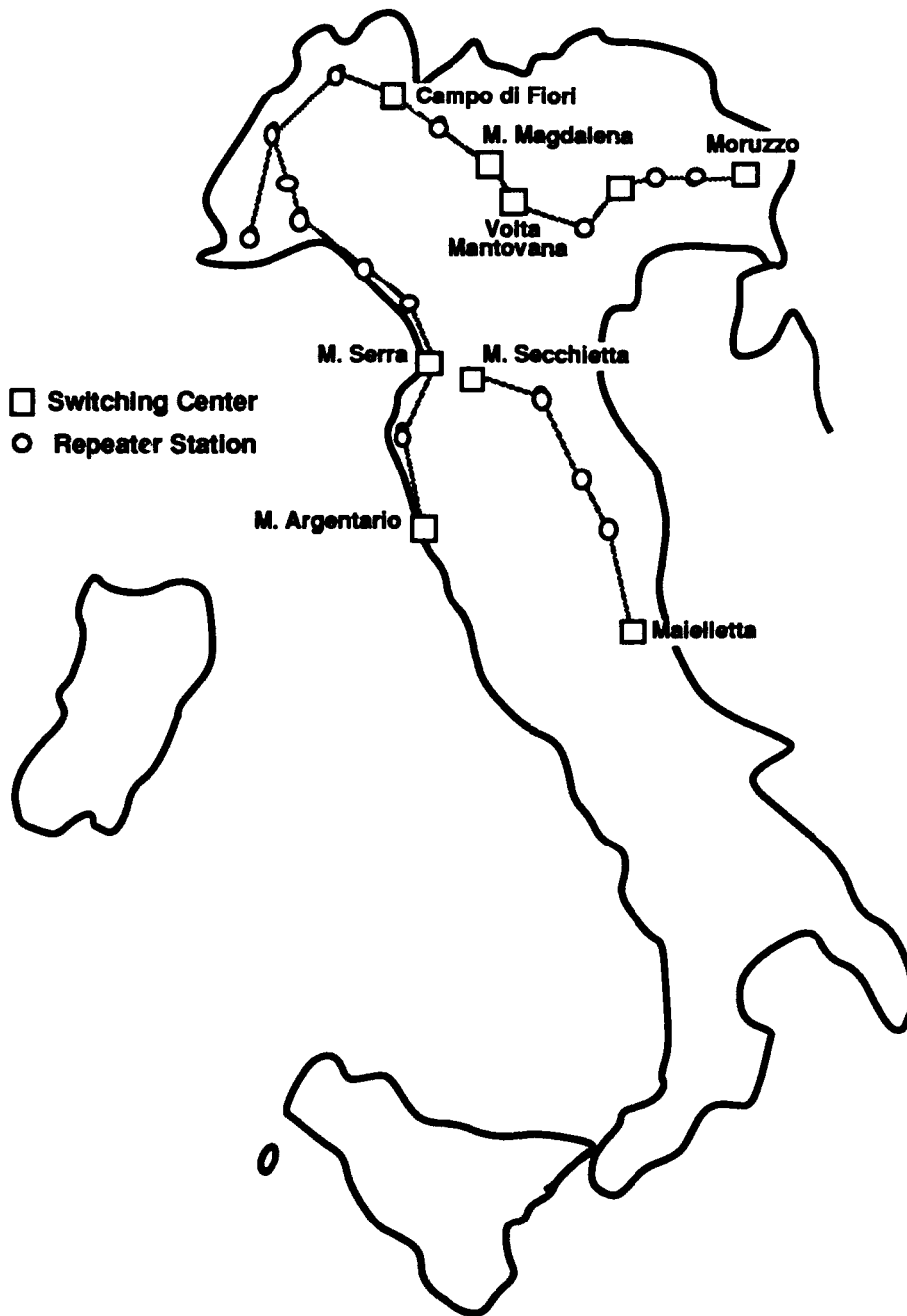

Figure 31. First Phase Digitalization of ITSN

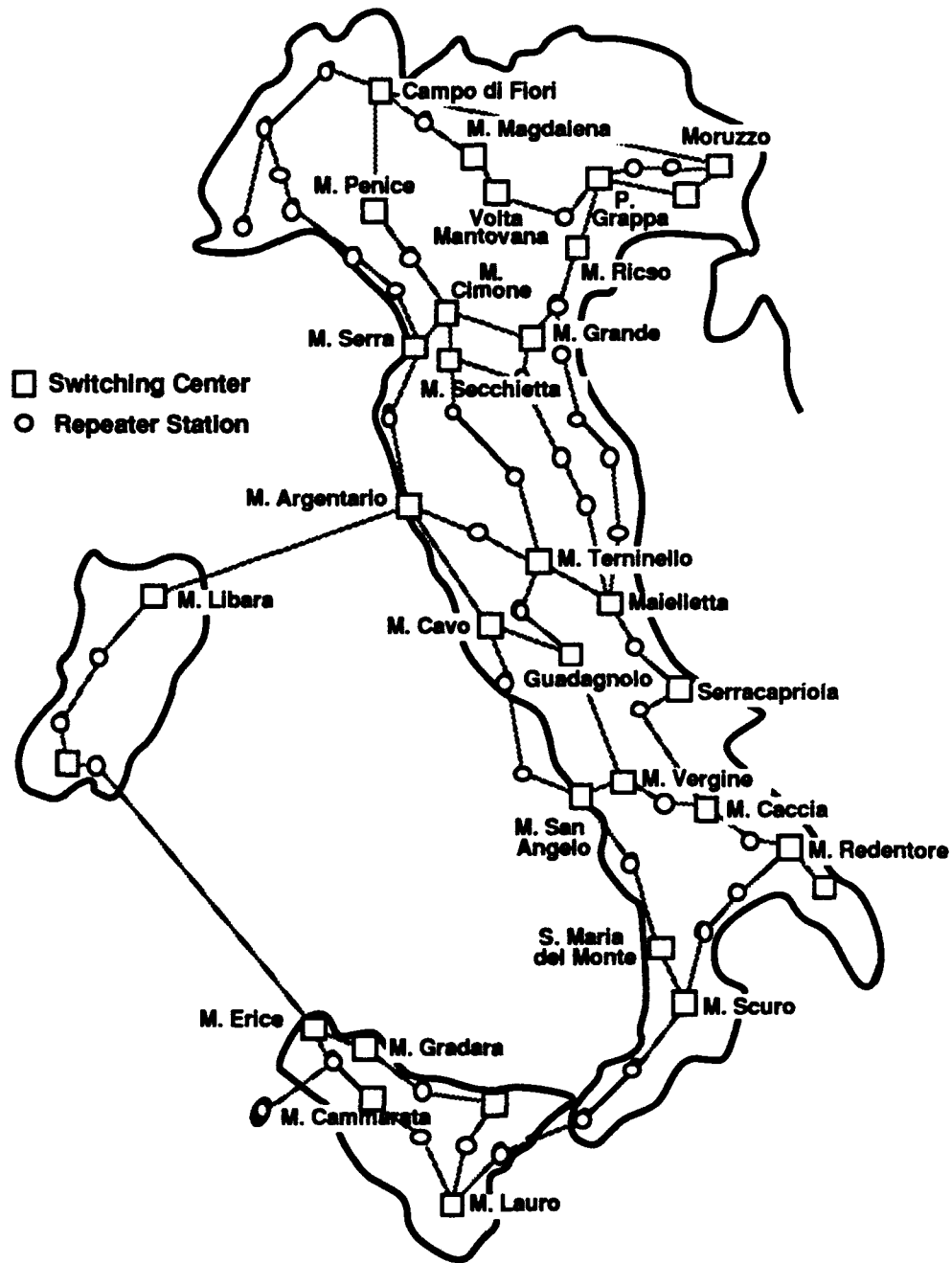

Figure 32. Final Digital ITSN (DITSN) Configuration

UNCLASSIFIED

Table 15. Comparison of National Military Communications Networks

Network	Country	Channel Rate	Level 1* Trunk Rate	Channels Per Trunk	Signalling Standard	IOC Date	FOC dATE
BEMILCOM	Belgium	64 kbps	2.048 Mbps	30 Ch	CCITT #7	1989	1993
GAFACS	Germany	64 kbps	2.048 Mbps	30 Ch	ITT System 12	Opn1	1992
FAF ISDN	Germany	64 kbps	2.048 Mbps	30 Ch	CCITT #7	1993	1999
DITSN	Italy	64 kbps	2.048 Mbps	30 Ch	CCITT #7	1991	2000
ASCON	Netherlands	56 kbps	1.544 Mbps	24 Ch	Channel Associated E&M	Operational	
NAFIN	Netherlands	64 kbps	2.048 Mbps	30 Ch	CCITT #7	Unk	1996
DEB/DCS	NATO-Wide	56 kbps	1.544 Mbps	24 Ch	Channel Associated E&M	Operational	

* Level 1 is the lowest aggregate of digital channels for bulk transmission.

UNCLASSIFIED

(This page intentionally left blank)

UNCLASSIFIED

IV. COMMUNICATIONS AVAILABILITY TO SUPPORT ACCS

A. COMMUNICATIONS FUNDING ELIGIBILITY WITHIN NATO

The NATO infrastructure program has a number of rules dictating what projects are eligible for complete or partial NATO funding. For communications, these rules can be summarized as follows:

- Strategic level communications (i.e., for PSC-level entities and above, and selected units) are considered eligible for NATO funding
- Communications for tactical forces (i.e., below PSC and wholly within a nation) are a national responsibility
- Those tactical level projects required to fill a NATO-imposed requirement are considered eligible for partial NATO funding. The amount depends upon the part that is required for NATO needs.

Based on these rules, IMG/NACMA prepared a draft diagram (see Figure 33) to show how this NATO funding eligibility concept affects ACCS communications. (Note that all communications interconnecting ACCS entities are national responsibilities.) This concept is a part of their effort to develop an ACCS criteria and standards document. As the diagram shows, ACCS is heavily dependent upon national networks to provide the data and voice transmission and switching. Only the access trunks (i.e., those circuits connecting the ACCS entity or facility, but excluding the access node) are eligible for NATO funding. For packet-switched data communications the funding criteria require great emphasis upon the creation and maintenance of data standards by a central body to enable data switch interoperability not only within a country, but also between countries.

B. DETERMINING COMMUNICATIONS AVAILABILITY

The ACCS Master Plan, Volume IV, Generic Design, states that ACCS will make maximum use of existing and planned national military and NATO digital transmission systems wherever possible. The Central Region Design Supplement recommends that ACCS communications use a common-user, meshed, digital "core" network formed by interconnecting transmission trunks derived from the national military digital

Inter-Site Communications

———— are considered eligible.
 - - - - are not considered eligible.
 Cross border links are considered eligible.

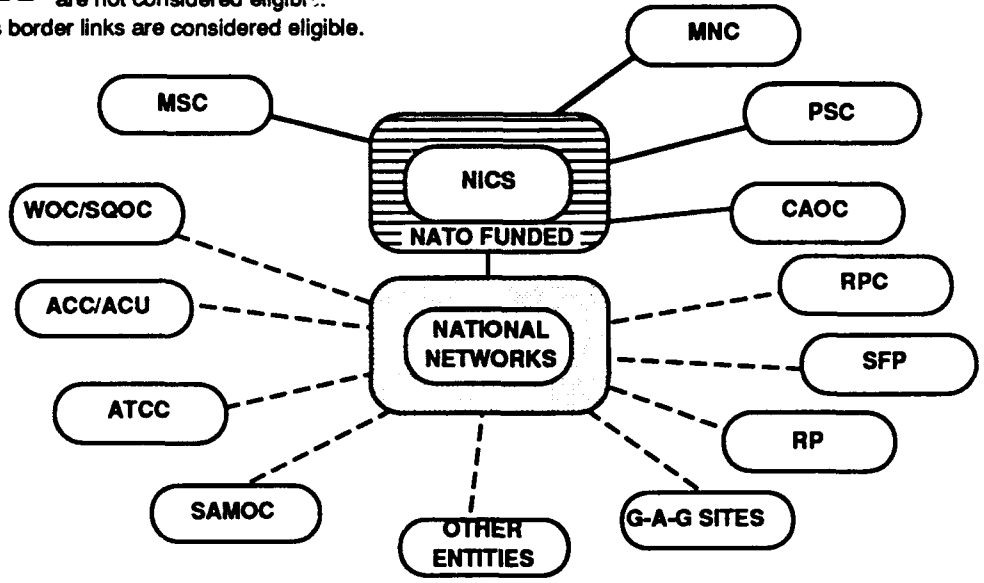

Intra-Site Communications

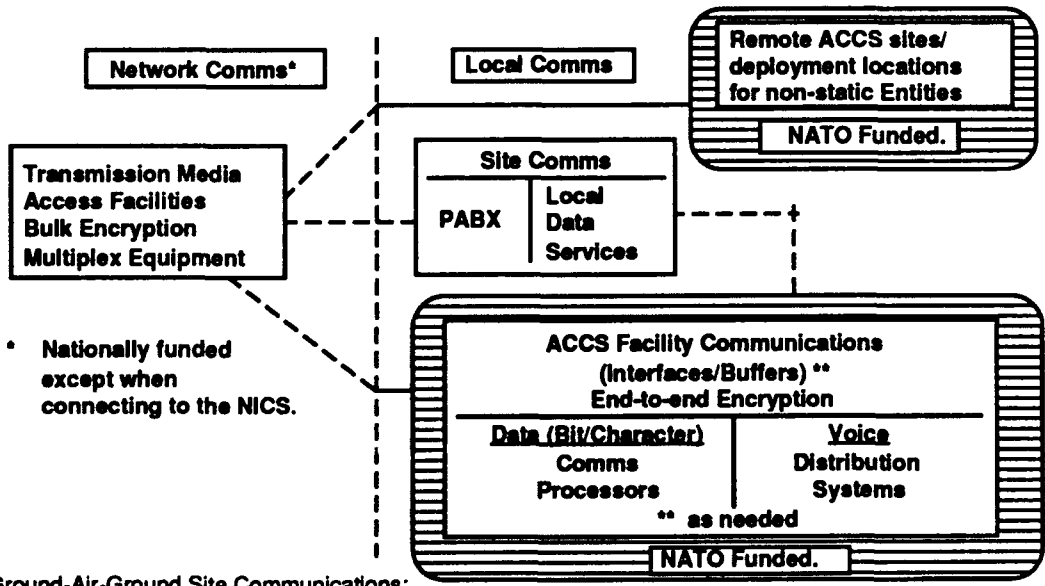

* Nationally funded except when connecting to the NICS.

Ground-Air-Ground Site Communications:

Gateways, HF, UHF, and MIDS, Radios and MPAs required for ACCS functions are considered eligible. VHF (ATC) and nationally required UHF Radios are not considered eligible.

Figure 33. NATO Funding Eligibility Concept for ACCS Communications

UNCLASSIFIED

communications systems of the region's three nations. The 5ATAF design supplement states that ACCS communications will use transmission trunks derived from the Italian military network and NATO digital circuits. The supplement does not, however, address how the circuit and packet switches needed to create an ACCS communication system would be provided from either source.

National military and PTT networks are wholly contained within the nation concerned. To establish a connection from one nation's military network to another nation's, the connection must cross the border between the two. This connection is referred to as a cross-border connection (CBC). The core network interconnected by CBCs is further augmented by interconnections with military communications operated by the four nations and by British, Canadian, and U.S. forces in the region. In particular, their tactical networks are needed to reach air bases and other entities not served by the core network. Based upon the NATO funding eligibility rules, the majority of ACCS communications transmission requirements must be satisfied by the national military systems, with limited NATO assistance (beyond providing CBCs).

CBCs can be established by the two nations concerned by means of a bilateral agreement that spells out the technical details and the type of data that can be passed over it. When such a connection is required by NATO, NATO agrees with the two nations concerned as to "how" and "where" the two networks are to be connected and what data will be passed over the connection. NATO pays for, and then owns, such a connection. Cross-border connections provided by the PTTs are done through bilateral agreements.

To determine whether all the necessary parts of the ACCS communications system will be available when the ACCS entities are implemented, it is necessary to analyze the Phase 1 Transition Programme and compare it to the expected availability of transmission plants, circuit and packet switches, data exchange standards, and communications technical standards and interfaces. All these elements must be present. Further, all these elements must be managed so that each is implemented in time to support the others, and so that all are ready to support the ACCS entity. An analysis of the availability of these elements to support ACCS is performed in the following paragraphs.

C. TRANSMISSION PLANT AVAILABILITY

The geographical location of the ACCS entities in the Central Region countries and 5ATAF, together with the national digital military networks that would support them, are shown in Figures 34 through 37. The dates shown for each entity are the implementation

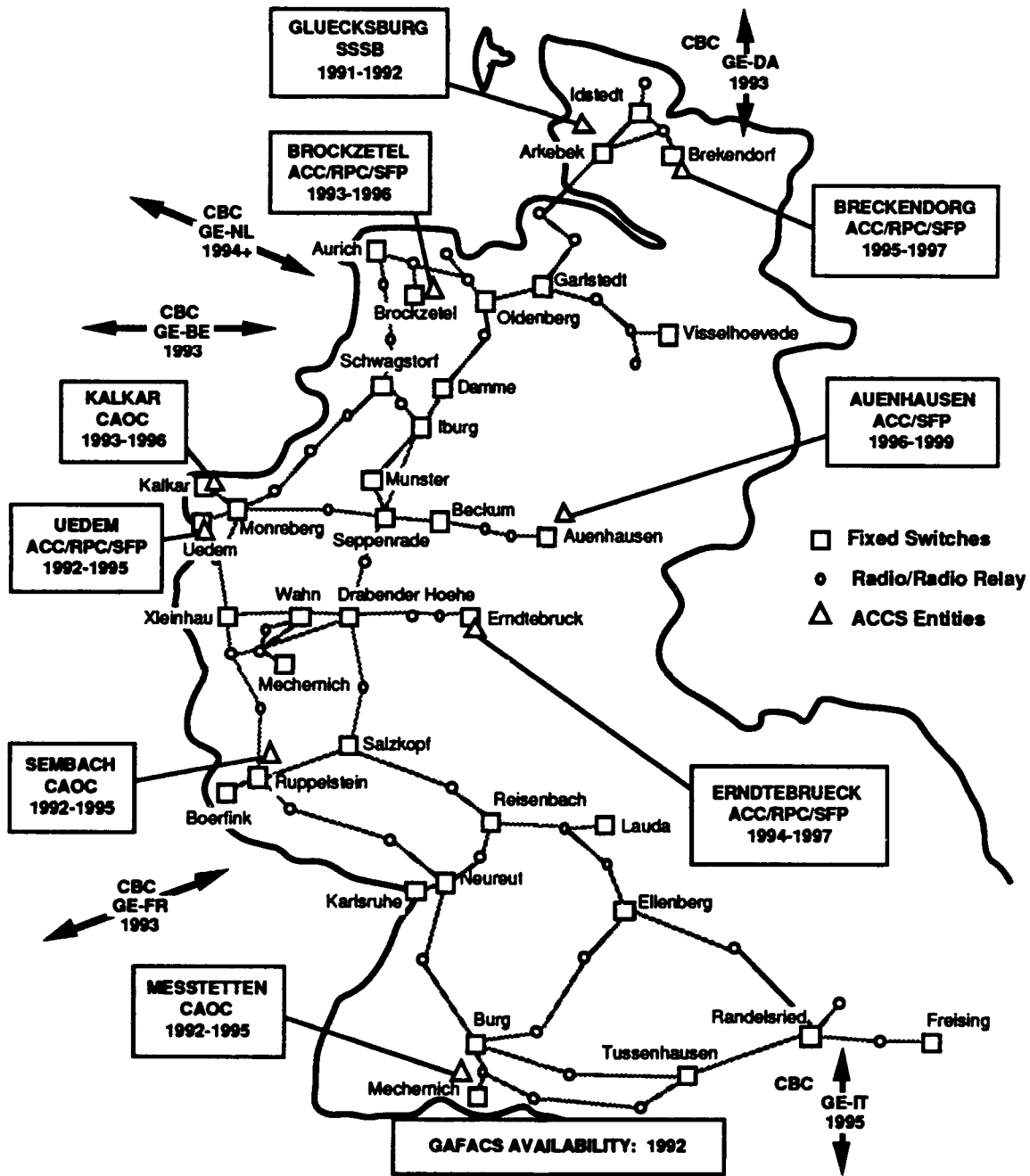

Figure 34. Digital Transmission Availability for ACCS In Germany

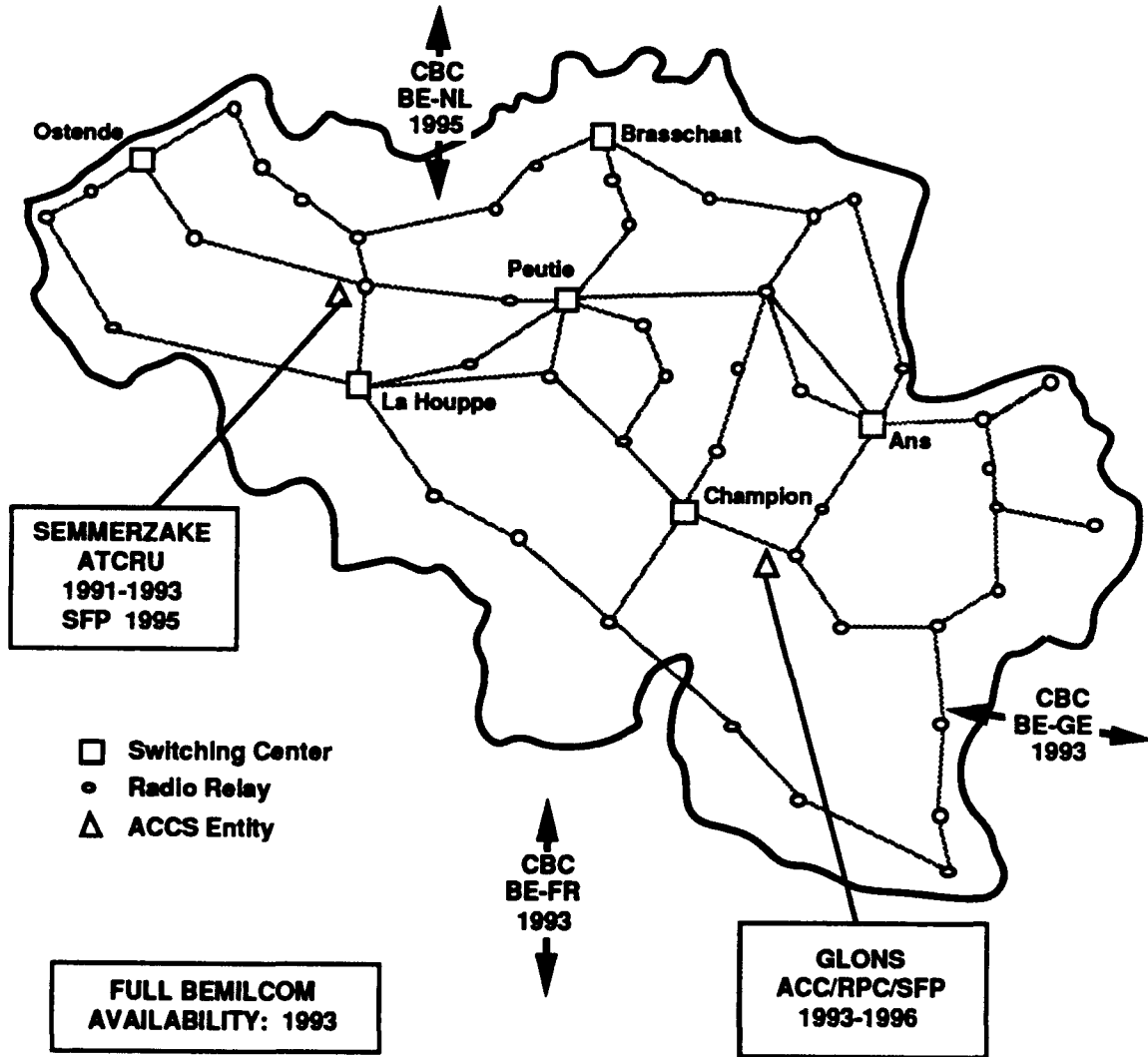

Figure 35. Digital Transmission Availability for ACCS In Belgium

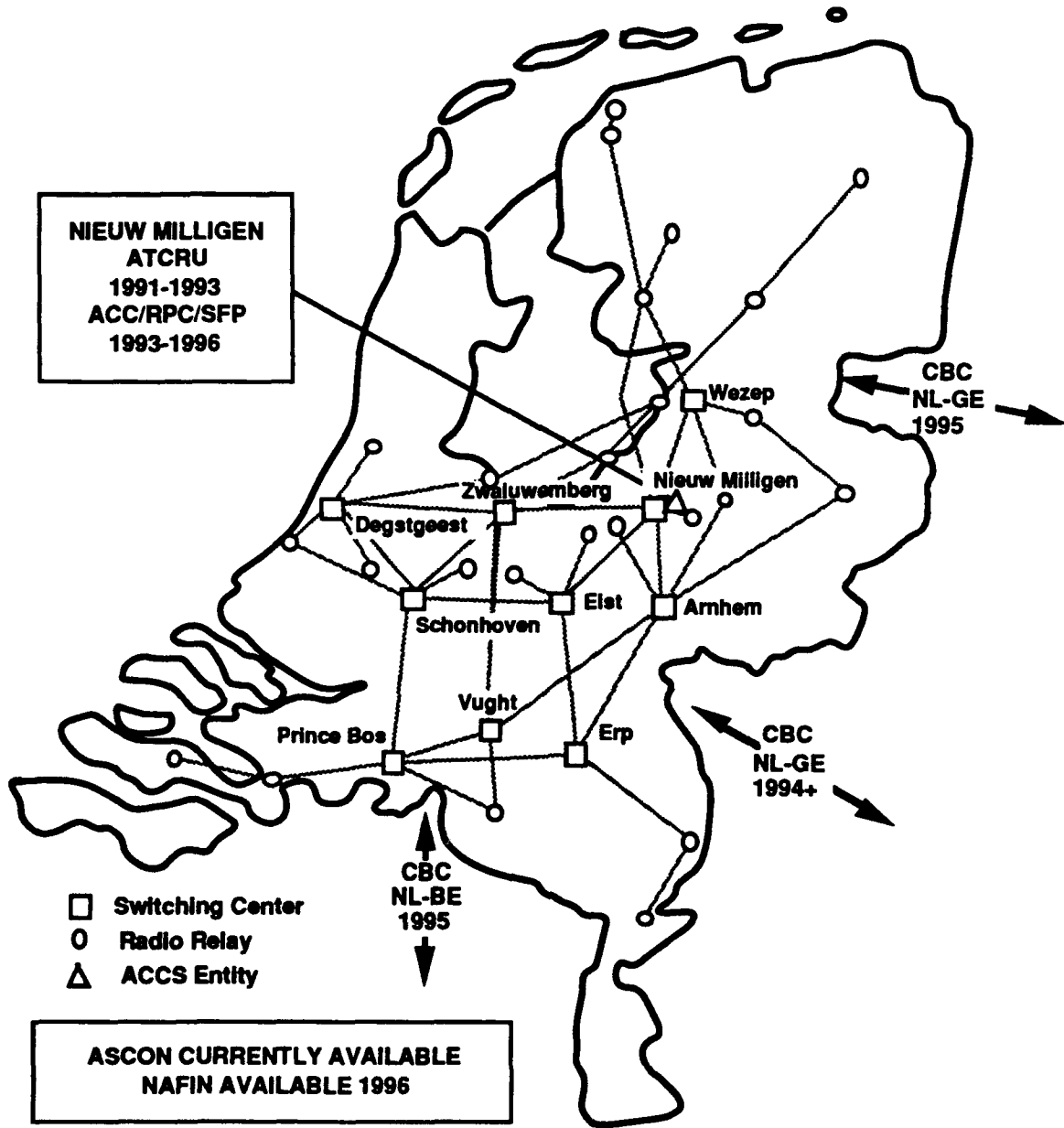

Figure 36. Digital Transmission Availability for ACCS In the Netherlands

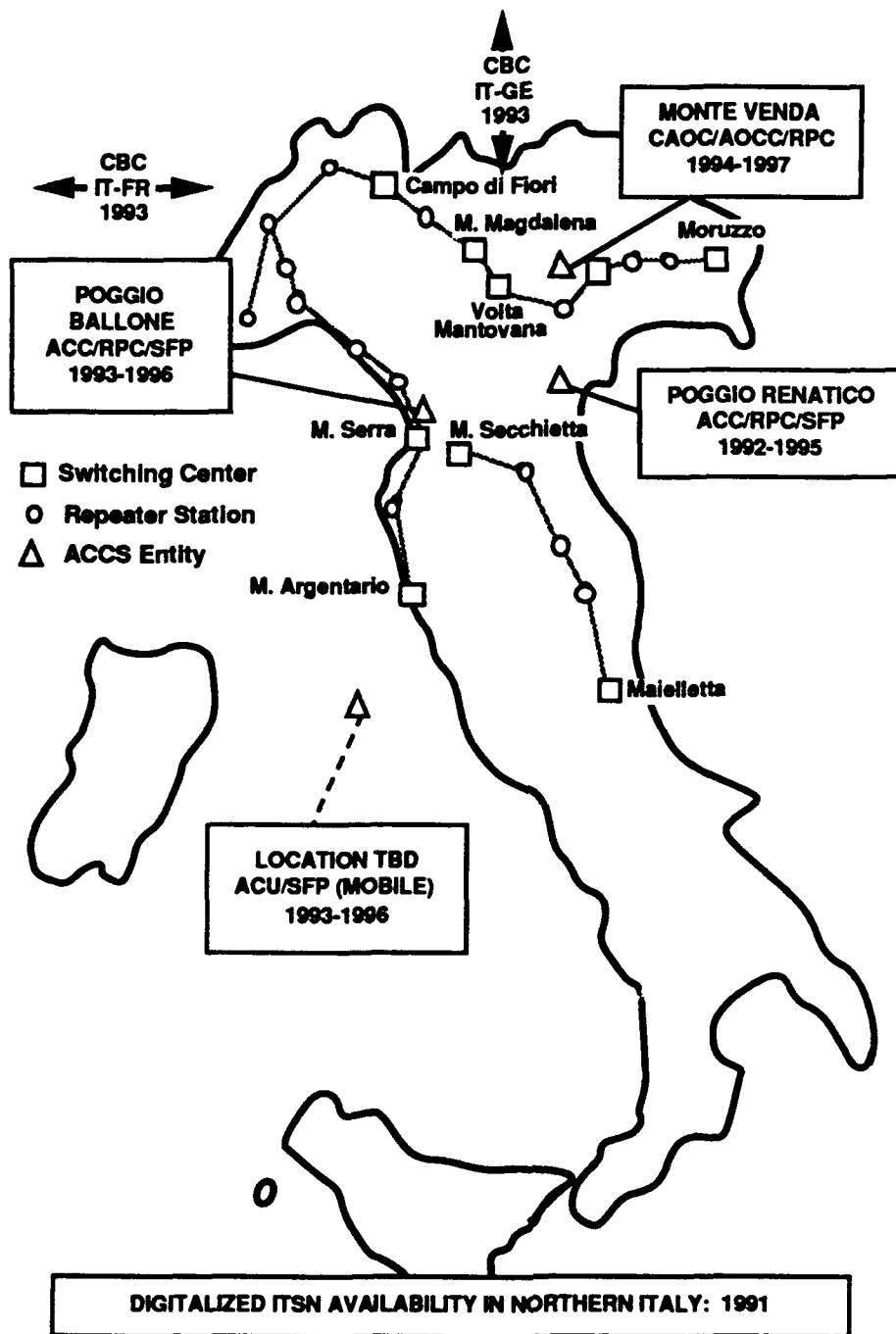

Figure 37. Digital Transmission Availability for ACCS in 5ATAF

UNCLASSIFIED

periods shown in the ACCS Master Plan, Volume V, Phase I Transition. Also shown are the reported completion dates for the communications networks. Figures 38 and 39 are included to illustrate that ACCS entities are also planned in the Phase I Transition Programme for the regions adjacent to the Central Region and 5ATAP (BALTA and France), and further illustrate the need for CBCs to be in place so that information can be exchanged throughout the NATO area.

In Germany, the GAFACS reportedly will be complete and in place by 1992. Hence digital transmission trunks and circuits will be available before most ACCS entities need them. ACCS entities are immediately adjacent to GAFACS switch nodes, so they could be connected to the network easily. Further, when the FAF ISDN is implemented, it will eventually incorporate the GAFACS, so the same entities can still be supported. All necessary CBCs from Germany (to Denmark, the Netherlands, Belgium, and France) are also scheduled to be in place by the implementation dates of Phase I ACCS entities. Figure 34 illustrates the proximity of ACCS entities to the GAFACS nodal switches, and also shows the planned CBC dates.

In Belgium, a similar situation prevails. The Phase I Transition entities are located in proximity to BEMILCOM nodes, and the network will be implemented prior to the ACCS entities. CBCs to Germany and France are also scheduled to be installed before the ACCS entities. This situation is illustrated in Figure 35.

The Netherlands shows a somewhat different situation. The ASCON is currently in place and has digital transmission capability, but since it uses different data standards (CCITT North American) than either Belgium or Germany (CCITT European), an interface must be used to interconnect the transmission plants. Such interfaces already exist (they are currently in use in the DCS in Europe), so they could be acquired. The NAFIN, which is scheduled to replace ASCON in 1996, eliminates this problem. Since NAFIN does replace ASCON, it is presumed that access nodes will be in many of the same locations. Therefore, digital transmission trunks should be available for the ACCS entities at Nieuw Milligen when they are implemented. The proximity of Nieuw Milligen to an ASCON nodal switch is illustrated in Figure 36, which also shows the CBC availability dates.

Within Italy, the digitalization of the ITSN will occur first in the north. This is the area that Phase I ACCS entities are planned for, and the digitalization is planned to be completed in 1992. The AFSOUTH assessment, however, is that the digitalization of the ITSN is only partially planned, and only for the northern sector. Assuming no further major technical or financial constraints occur, the system should be digitalized in time to

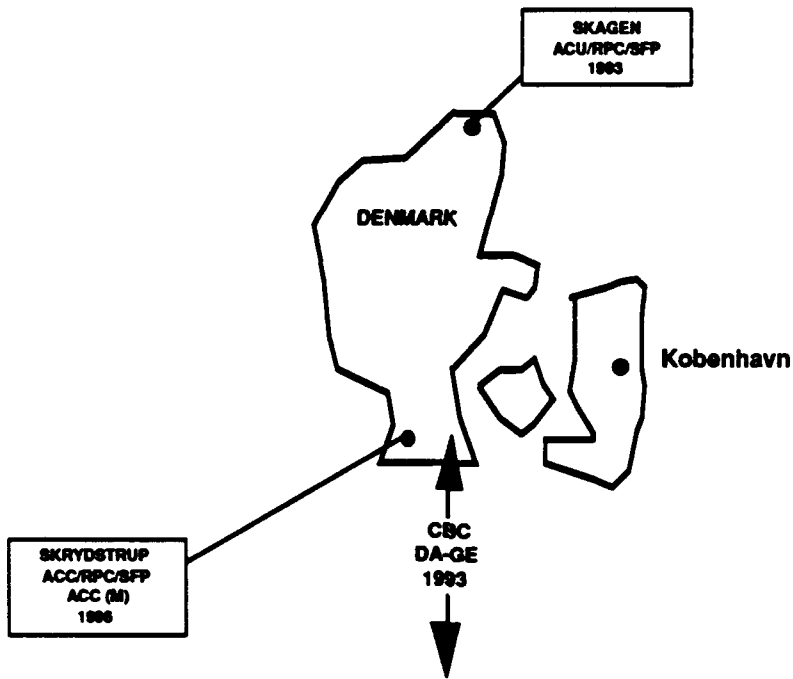

Figure 38. ACCS Entities in the Baltic Approaches (BALTAP)

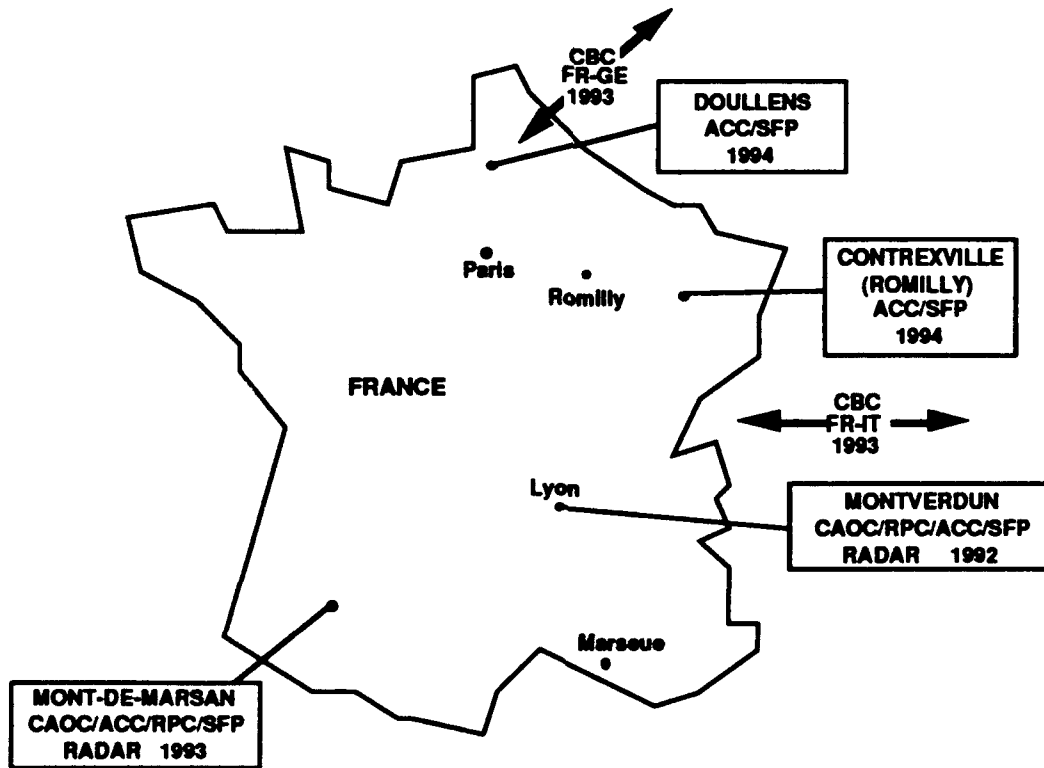

Figure 39. ACCS Entities In France

UNCLASSIFIED

support ACCS entities in the north (which are in proximity to the ITSN access nodes), but digital transmission availability for later ACCS entities in the south is not as probable. CBCs to France and Germany are scheduled to be implemented in time to support the ACCS entities. The situation in Italy is illustrated in Figure 37. Although Poggio Renatico appears to be somewhat isolated from the new digital networks, its position in the relatively industrialized northern part of Italy and in proximity to the old analog portion of the ITSN makes it likely that it can be connected to the digital system, but this information is not yet known to the IDA study team.

The Phase I Transition Programme includes ACCS entities in nearby Denmark (BALTAP) and France, as well as the Central Region and 5ATAF. For this reason, Figures 38 and 39 are included to show those planned entities in the BALTAP and France, respectively, as well as the CBCs that will connect them to the Central Region and 5ATAF.

Table 15 above compares the transmission and signaling of the national military networks and the DCS. As this table shows, the newer networks will use CCITT Europe transmission standards (2.048 Mbps Level 1 trunks containing 30 circuits of 64 kbps each) and CCITT #7 signaling standards. For interoperability of circuit-switched networks, gateways will be necessary to interface GAFACS, ASCON, and the DCS to the newer networks. The lack of signaling interoperability would not affect the ACCS packet-switched network. This network would use semi-permanent digital trunks to connect the packet switches, which would provide their own signaling.

In summary, the ACCS entity transmission circuit needs can be provided by the national military communications systems, despite some interface problems. Information on the bandwidths that could be made available to ACCS is not known, but most of the ACCS circuits will simply replace the circuits already justified, approved, and being carried by existing national transmission systems. However, the ACCS requirement is now for mostly common-user digital circuits, rather than dedicated analog circuits.

Table 16 summarizes the ACCS entity and national digital transmission plant availability. This table shows that, with a few exceptions, the required transmission capability is planned to be available within a year of the ACCS entity project date. The exception is Nieuw Milligen (NL). This entity will require an interface unit for interoperability until such time as NAFIN is completed.

UNCLASSIFIED

Table 16. Transmission Trunk Availability

Location	ACCS Entity	Implementation Period	Trunk Available	CBC Available	Minimum* Slack Time
Germany					
Uedem	ACC/RPC/SFF	1992-1995	1993	1994 (NL)	1
Sembach	CAOC	1992-1995	1993	1993 (FR,BE)	2
Messtetten	CAOC	1992-1995	1993	1993 (FR,BE)	2
Brockzettel	ACC/RPC/SFP	1993-1995	1993	1993 (DK)	2
Kalkar	CAOC	1993-1996	1993	1993 (NL)	3
Erdlebrueck	ACC/RPC/SFP	1994-1996	1994	N/A	2
Breckendorf	ACC/RPC/SFP	1995-1997+	1993	1993 (DK)	4
Auenhausen	ACC/SFP	1996-1997+	1993	N/A	4
Belgium					
Semmerzake	ATCRU	1992-1993	1993	N/A	0
Glons	ACC/RPC/SFP	1993-1995	1993	1993 (GE)	2
Semmerzake	SFP	1995	1993	N/A	2
Netherlands					
Nieuw Milligen	ATCRU	1991-1993	1995	1994 (GE)	- 2 **
Nieuw Milligen	ACC/RPC/SFP	1992-1995	1995	1993 (BE)	0
Italy					
Poggio Renatico	ACC/RPC/SFP	1992-1995	1991	1995 (GE)	0
Undetermined	ACU/SFP (Mobile)	1992-1996	Unknown	N/A	Unknown
Poggio Ballone	ACC/RPC/SFP	1993-1996	1991	1995 (FR)	1
Monte Venda	CAOC/RPC/AOCC	1994-1997+	1991	1995 (GE)	2

* Minimum slack time is the lesser of the number of years between the availability of trunk or CBC and the end of the ACCS entity implementation period.

** Communications for Nieuw Milligen can be provided earlier by the existing ASCON system, but a gateway will be required to provide interoperability with the other national systems.

D. DIGITAL VOICE CIRCUIT SWITCH AVAILABILITY

All of the national networks have a circuit switch capability and a digital voice capability. Consequently, the establishment of voice circuits is entirely possible. The capability will certainly be available. The major problem here is that the signaling data used by each system is not standardized. As a result, interfaces will be required so that one system can signal a call to another system.

E. ACCS PACKET DATA SWITCH AVAILABILITY

The packet data switches are essential elements of the ACCS data communications system. These switches provide the needed routing capability that enables the packet data messages to be directed to their destinations rapidly and reliably. Analysis of the Phase 1 Transition Programme reveals that no packet data switches are being procured. Indeed, there are no funds budgeted for any ACCS communications items, including packet data switch procurement and installation. This is a critical shortcoming.

UNCLASSIFIED

The importance of an ACCS packet-switched data network to replace Link 1 cannot be overemphasized. ACCS is an aviation system requiring much shorter response times to cope with modern air warfare. ACCS offers a quantum increase in knowledge of the air picture which will allow faster aircraft turn-around times, with faster response to threats. Air track data is the most important data that the ACCS works with and responds to. With new data fusion techniques, this data can be refreshed as quickly as every 5 seconds, twice as fast as with older systems that were limited to the scan rates of long-range radars. The 5-second air track update rate is the primary driver for a common-user packet-switched network dedicated to ACCS. Air track data are currently transmitted over dedicated point-to-point circuits (Link 1) in NATO, with a very limited message set and slow transmission speeds. This arrangement is not practical for handling the volume of air track data in ACCS. A common-user system has great advantages over currently-used point-to-point data link systems. It can distribute data to users in parallel, requires far less circuitry, and is faster than point-to-point systems.

Figure 33, discussed previously, shows that NACMA considers the provision of communications between ACCS entities to be a national responsibility. Presumably, this includes switching, as well as transmission, capability. The statement of work, which includes the development of a specification for a notional ACCS communications system including ground-ground and ground-air-ground systems, does not address packet data switch requirements. If packet data switches are not procured for ACCS, then data switch standards will have to be provided to the various national systems if the packet data systems of the various nations concerned are to interoperate.

It is not apparent that the individual nations have standardized on packet switches for their respective national military packet-switched systems. While Belgium and the Netherlands have firm plans for packet-switched data systems they will not necessarily be interoperable, as there is no current requirement that they should be. Further, German military plans for a packet-switched system are not clear, and when such a system will be implemented is not known. As a result, the feasibility of using national military packet switches for ACCS data communications is not known. Operationally, such use of national switches for NATO air track data may be unacceptable owing to the greatly increased throughput requirements to meet the near-real-time air track data transfer requirements. The use of a commercial (PTT) packet system was not considered, since PTT systems are to be used only as a backup for ACCS communications. In any event, PTT systems do not allow for multiple address messages. These systems use a

UNCLASSIFIED

connection-oriented protocol that requires a multi-addressed message to be sent multiple times, one transmission per addressee.

The great bulk of ACCS data can probably be sent via national packet data networks (if and when they exist and to the degree that they are interoperable) because most of this data is not severely time-critical. Information such as status, allocations, mission results, alert stages, and file transfers are in this category. However, there is a unique class of data peculiar to ACCS that simply requires a dedicated network to meet its response time requirements. This is the air track data obtained from the sensor network and which, when properly fused, correlated with other air track sources, and identified, constitutes the RAP that is the core of ACCS operational functioning.

Another major concern in air track packet data switching is the lack of an effective multiple address switching protocol that would allow one message (e.g., the RAP) to be sent simultaneously to all addressees or users that need the data. The RAP data file is usually a lengthy message; hence, if the RAP has to be sent to each user individually, the data transmission requirements will be greatly increased. The use of multiaddressed packets is clearly required to reduce throughput, yet such protocols do not presently exist. The connectionless protocol portion of X.25 (which would handle multiaddressing) is vague and has not been standardized. However, it appears that ACCS packet data communications is being left as a national responsibility with no plans for NATO or NACMA action in this area. Also, the national military packet-switched systems might not be interoperable, although the IDA study team was not able to obtain any information on this. In any case, with the exception of the LISA effort, there are no plans to satisfy the most critical ACCS information transfer requirement, the replacement for Link 1.

F. DATA EXCHANGE STANDARDS

The development of data message standards in NATO is a responsibility of ADSIA. ADSIA Working Group 4 (WG-4) had developed the TADIL-J message standards and documented them in STANAG 5516. WG-4 was therefore the logical body to develop the ACCS message standards, which are based on the TADIL-J standards. Accordingly, the nations and MNCs agreed to the following tasking for a ground-ground data system in support of ACCS:

UNCLASSIFIED

ADSIA WG-4 is tasked to develop and maintain the bit-oriented procedural standards for a ground-to-ground data link necessitated by the operational requirement of the Air Command and Control System, including message catalogue, data element dictionary and standing operating procedures.¹

This task was assigned to ADSIA WG-4 for development and maintenance. WG-4 has in turn established a sub-group to concentrate on this effort that is entitled "Link in Support of ACCS (LISA)." The procedure is to use the ACCS System Specification contractor-developed Information Exchange Requirements (IER) as the basis for development of the ACCS message catalogue. A contractor will develop the IERs, but NATO policy will not allow industry to determine operational requirements. Therefore SHAPE, supported by a user involvement group, will establish the operational requirements, to be forwarded to the contractor by NACMA. The contractor will conduct analyses and make proposals to NACMA which, after approval, will be documented as system specifications, including requirements for data exchange within and between entities. The IERs between entities will be formally validated by SHAPE and sent to ADSIA for development into message standards. The ADSIA standards will then be required for the system and entity designs. This process is depicted in Figure 40.

The schedule for development of the IERs is shown in Figure 41. It shows that the final IERs will not be available until the 20th month after start of contract. The contract began in January 1991, so the IERs should be completed by September 1992. In the interim, ADSIA will use the ACCST-developed IERs to identify data elements for ACCS messages. These will be recommended with the final IERs. It therefore appears that there is a definite formal procedure to establish ACCS message standards, and that the process is working. However, it is a lengthy, cumbersome process, and it will require careful coordination to ensure that the process is accomplished smoothly.

Within NATO, development of the required technical transmission standards is a responsibility of the Tri-Service Group on Communications-Electronics Equipment (TSGCEE). The TSGCEE developed the technical transmission standards for Link 16 documented in STANAG 4175. (STANAGs 5516 and 4175 together completely describe Link 16.) A similar set of standards is required for the ACCS packet data system. Formal tasking to the TSGCEE similar to the tasking for message standards has not been accomplished. The Secretary of the TSGCEE has indicated that these standards will be based upon a common-user packet-switched system. However, it does not appear that work has started on the development of these essential standards.

¹ ADSIA Memorandum, ADSIA(WG-4)-RCC-C-21-90, Subject: Task for ADSIA WG-4 as a Result of the 26th ADSIA Plenary, 21 May 90, UNCLASSIFIED.

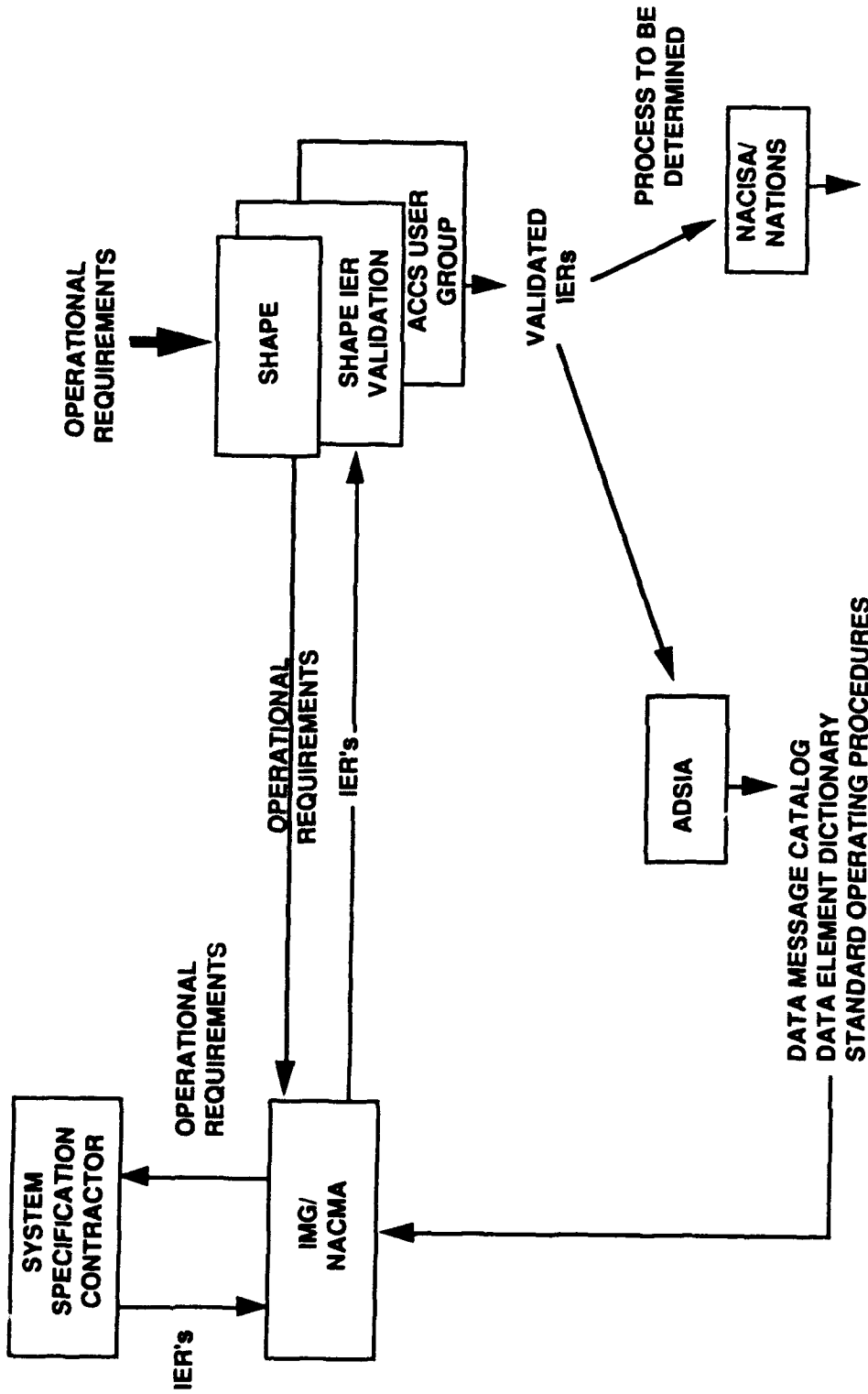

Figure 40. Information Exchange Requirements (IER)

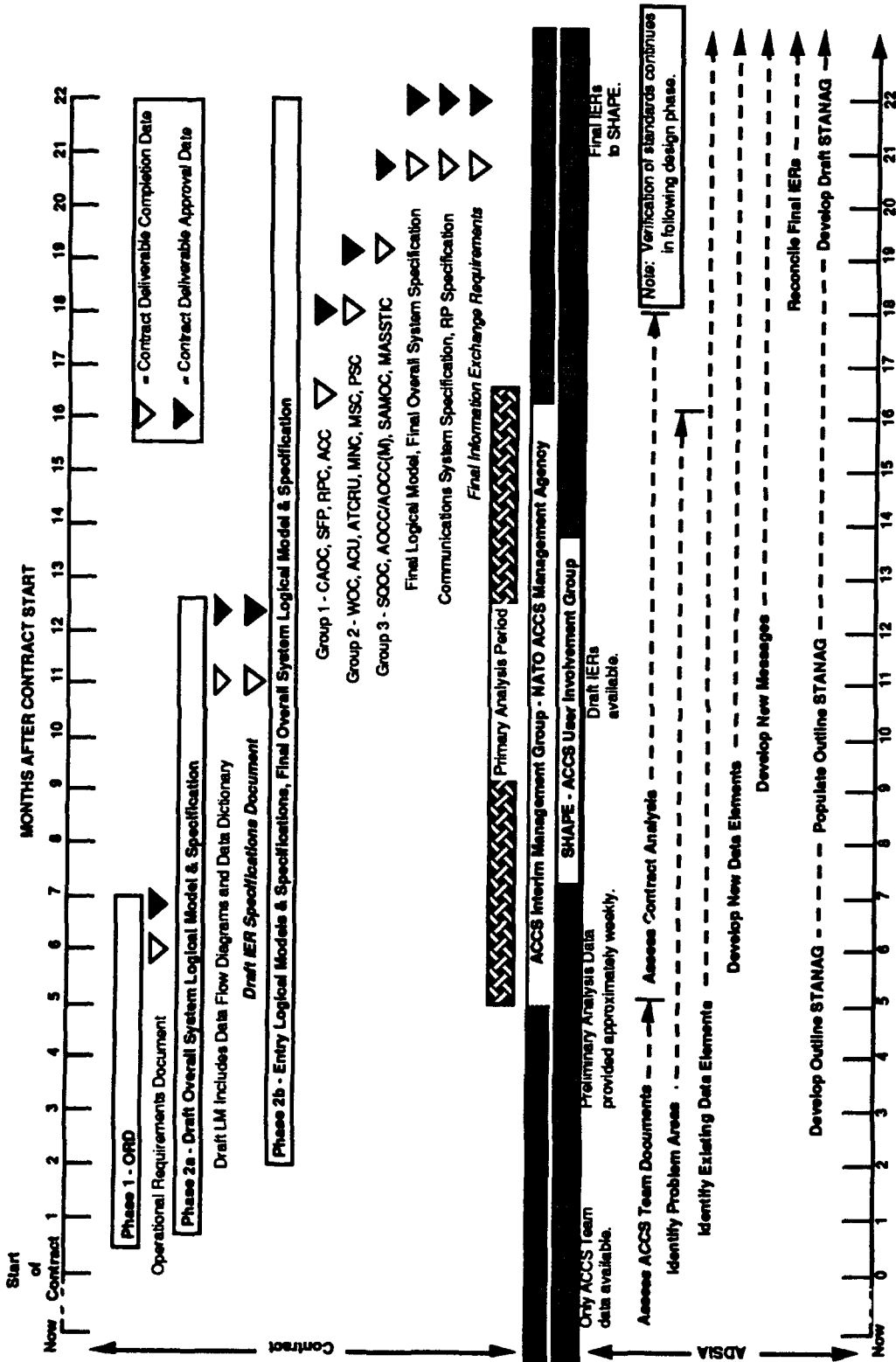

Figure 41. ADSIA, SHAPE, ACCS IMG Co-operative for the Development of ACCS IERS

G. ACCS MANAGEMENT ISSUES

Because there are so many NATO bodies involved in the planning, development, and integration of the communications support of ACCS, it is sometimes difficult to associate all the diverse parts of ACCS communications with the responsible activity. It is clear, however, that there does not seem to be an overall, coherent plan to achieve an ACCS communications system implementation strategy with measurable milestones. A considerable number of personnel, both NATO and contractor, are trying to contribute to the establishment of ACCS communications, and there is a need to focus all this activity on a coordinated and coherent objective to achieve communications that can support the planned ACCS implementation. As an example, NACMA contends that, in accordance with NATO infrastructure rules, communications between entities is a national responsibility. However, CBCs between entities are in part a NATO responsibility. Message and transmission standards are also a NATO responsibility. There are long-term initiatives by SHAPE to replace the NICS ultimately with a strategic level (PSC and above) multipurpose, common-user, packet-switched data system that ACCS may or may not use, according to whatever requirement ACCS states. A partial list of those agencies concerned with ACCS information transfer is presented in Table 17.

There is an urgent need for a single ACCS communications implementation plan that shows who is doing what and directs all the activities towards the goal of ACCS data communications support. This plan and its implementation must be managed and monitored by NACMA to ensure that the communications support will be available when ACCS is implemented. Additionally, such a plan would provide guidance to other NATO bodies in areas such as:

- Communications systems architectures
- System security architectures
- Specific military requirements for items such as precedence, multiaddressing, and priorities
- Real-time transmission requirements
- Strategies and procedures to supply flow control in a common-user network
- System and network management
- Interface and gateway architectures
- User access architectures.

UNCLASSIFIED

Table 17. Agencies Responsible for ACCS Information Transfer

Organization	Responsibilities
NACMA	ACCS System Specification, including communications subsystem Information Exchange Requirements
NATO Committees ADSIA WG-4 TSGCEE	Development of message standards Development of transmission standards
MAS	Standards approval
NACISA	NTTS NATO common-user data transfer capabilities NICS: TARE and IVSN Long-term NATO communications
SHAPE	Operational requirements Approval of Information Exchange Requirements Coordination of SHAPE Technical Centre actions Coordination with ongoing Army Tactical Command and Control Information System (ATCCIS) standards
NATO Nations	Installation and operation of national military communications systems

Many parts of the above are being done by the various bodies. However, it all needs to be brought together in a single implementation plan with measurable milestones and managed by a single agency.

H. TRANSITION ISSUES

The Phase I Transition Programme seeks to maintain present capabilities during the implementation period. This implies that much of the existing equipment and installations will need to be kept in operation well beyond the year 2000. This will create a constantly changing and mixed environment which by itself will cause interoperability problems. To maintain the older systems in operational condition will be difficult owing to lack of spare parts and the non-availability of equivalent equipment. On the other hand, newer systems which have been fielded after the initial NADGE program are likely to operate well into Phase 3 (2003-2008) without major technical problems. The mixed ground environment which evolves after 1995 will pose a challenge to interoperability of command, control and management functions that must be considered as well as the entity implementations themselves. One way to alleviate some of these problems is to provide the remaining

UNCLASSIFIED

NADGE sites the capability to communicate with the ACCS entities via the new ACCS data link as early as possible. Replacement of Link 1 with the ACCS data link would provide significant operational advantages:

- All external ground-ground communications would be conducted in accordance with the same protocol
- The ground communications system could be utilized more effectively
- Classified air picture and battle management data required at NADGE units to perform their air mission control tasks could be transmitted
- Exchange of data between differently classified link systems (Link 1 is unclassified) could be conducted.

The ACCS system, which is more oriented toward C² information systems than current NADGE systems, will depend on transmission of a large quantity of battle management data via the operational ACCS data network. A capacity at the remaining NADGE sites to receive, display and transmit some of these data could significantly reduce the workload and increase the efficiency both at ACCS entities and at the old NADGE units. Data mainly concerned are:

- alert sites
- alert stages
- airbase status
- weapons status
- site status
- allocations
- emergency actions
- data related to air mission control
- mission results.

The improvements suggested could be achieved by using a combination of the communications processor, a protocol conversion processor, cryptographic equipment, and a limited number of personal computers at the management and air mission control positions of the NADGE site, all connected via a local area network. The communications processor (in effect, a front-end processor) and cryptographic equipment could be used when transitioning the unit into an ACCS entity at a later stage. This would provide a continuous communications interface with the ACCS communications network.

UNCLASSIFIED

(This page intentionally left blank.)

UNCLASSIFIED

V. CONCLUSIONS AND RECOMMENDATIONS

A. CONCLUSIONS

ACCS is a very communications-intensive acquisition. Communications is so much a part of the total system that it would be foolish to deploy a new ACCS entity unless the communications elements to support it are in place by the time the entity is expected to be operational.

ACCS demands more modern communications networks than are currently in place throughout the Central Region and 5ATAF. The transmission systems must be digital to support secure voice and high data rates. A packet switching system is necessary to handle and distribute the near-real-time air track data. The data switching network for air track data may have to be dedicated to ACCS since it is such an ACCS-unique requirement. The character-oriented general data traffic and the digital voice can, in all probability, be supported by national packet-data-switched and circuit-switched systems. Here, however, complete interoperability for data and voice signaling must be assured. Currently it is not assured. ACCS cannot be implemented until these transmission and switching networks are in place, and unless each of the networks is interoperable with like networks in adjacent regions.

There are no budgeting or planning data concerning the procurement of packet data switches for ACCS, and yet these switches are required to realize a viable data exchange system between ACCS entities. This indicates that there may be a lack of intent to ever implement the critically needed ACCS packet switched data system to replace Link 1 and provide the required information exchange to integrate ACCS entities. The absence of planning or budgeting data is also evident in the case of voice circuit switches.

For digital transmission systems, ACCS will primarily depend upon national digital military networks which are being or have been installed in the Central Region and 5ATAF. The NTTS (which also depends on these national networks) may possibly carry some of the ACCS circuits. Cross-border connectivity of these transmission systems is also required, whether it be provided by bilateral agreements between nations, or through the CBCs of the NTTS.

UNCLASSIFIED

The national military transmission systems and NTTS CBCs are expected to be available in time to support the ACCS entities in the Phase I Transition Programme in the CR and 5ATAF, but interfaces (gateways) will be required between some of the older and some of the newer networks because of dissimilar transmission and signaling standards. Further, there is no guarantee that the NTTS CBCs can be used by ACCS below PSC level.

To ensure computer-computer understanding and provide effective transmission of ACCS messages on the data communications network requires a standardization of data *message* formats into catalogs, data element dictionaries, and standard operating procedures (protocols). This work is underway, but the process will be long and complex. Additionally, data *transmission* protocols must be delivered and implemented. At issue here is what standards will be used and whether new ones will be required. In particular, the issue of a multiaddress standard requires attention.

Because there are numerous NATO agencies and committees involved in the planning, procurement and integration of ACCS communications support, it is difficult to understand all facets of ACCS communications. In general, there is no one agency to monitor and direct these efforts to ensure that they result in clearly-defined ACCS communications deliverables, in accordance with definite milestones, to meet scheduled needs. There is an urgent need for a single coordinated ACCS communications implementation plan that directs the many activities concerned towards the goal of ACCS data communications support by showing what is to be done, by whom, and by when.

With the significant reduction of the threat and concurrent reduction in funding, a new ACCS concept with considerably fewer entities (many of which are mobile) is under development by a SHAPE team known as ORACLE. This new ACCS concept could dramatically change the communications requirements, but the principles that support this study will remain valid even if the post-CFE world should yield new findings.

Table 18 summarizes the study's conclusions regarding availability of communications to support the ACCS Phase I Transition entities. The following definitions apply to the degrees of risk shown in the table:

- **HIGH RISK:** Will pace ACCS implementation unless immediate action is taken and followed through.
- **MEDIUM RISK:** Will slow ACCS implementation unless action taken soon and carefully monitored.
- **LOW RISK (not applicable on this table):** Will not slow ACCS implementation if current efforts are continued.

UNCLASSIFIED

Table 18. Availability of Communications to Support ACCS

Necessary Element	Degree of Risk		Remarks
	High	Medium	
Transmission Systems		√	Disimilar standards require gateways for GAFACS & ASCON. CBCs not assured.
Digital Voice Circuit Switching		√	Interfaces required between some national military systems.
Packet Data Switching	√		No known plans for the most critical ACCS communications requirement.
Data Exchange Standards		√	IEFs not available until Sept. 1992. ADSIA WG-4 working on message standards. Work on transmission protocols not begun.
Total System Management		√	Difficult to coordinate/control multiple agencies. No coordinated implementation plan exists.

HIGH RISK: Will pace ACCS implementation unless immediate action taken and followed through.

MEDIUM RISK: Will slow ACCS implementation unless action taken soon and carefully monitored.

B. RECOMMENDATIONS

Until budgeting plans, with implementation dates, are known for circuit and packet switched networks that can be used to support ACCS, *no* ACCS entities should be supported. The United States should maintain its stated position that the availability of communications (including required switching capabilities) is a prerequisite for supporting the acquisition of ACCS entities.

The preparation of the ACCS data message standards must be carefully coordinated to maintain interoperability between all parts of the communications system, and to ensure the availability of the data messages for ACCS entities when installed. Similarly, the preparation of multi-address data transmission standards must be started and carefully monitored. The TSGCEE should be tasked by NATO to begin work on these standards.

If not already doing so, NACMA should develop a coordinated, integrated communications implementation plan with milestones and ensure that everyone works toward the same goals and that the many ongoing efforts result in a communications system that can support ACCS.

Since post-CFE implications of ACCS and its communications were outside the scope of this study, further study would be required to determine communications available for ACCS under the ORACLE concept. This report could be used as a starting point for such an effort.

UNCLASSIFIED

(This page intentionally left blank)

UNCLASSIFIED

UNCLASSIFIED

REFERENCES

3rd Revise of the Draft Minimum Military Control Requirement (MMCR) for Rationalised NTS, AC/317(WG/1)N/141(3rd revise), North Atlantic Council, NATO Communications and Information Systems Committee, Communications Systems Working Group, 17 August 1990, NATO RESTRICTED.

A Review of the NATO Air Command and Control System Regional Designs, IDA Paper P-2404, Revised Technical Review Draft, August 1990, SECRET.

ACCS Communications Requirements Synopsis - Southern Region, 3835.01.15/SHCRC/90, Supreme Headquarters, Allied Powers Europe, 22 June 1990, NATO CONFIDENTIAL.

ACCS Communications Requirements Synopsis, 3835.01.15/SHCRC/89, Supreme Headquarters, Allied Powers Europe, 15 December 1989, NATO CONFIDENTIAL.

Air Command and Control System Master Plan, Vol. 4: Overall ACCS Design, Generic Portion, Air Command and Control System Team, ACCST(88)424/057, 8 July 1988, NATO CONFIDENTIAL.

Air Command and Control System Master Plan, Vol. 4: Overall ACCS Design, Regional Supplement 3 - Central Region, Air Command and Control System Team, ACCST(87)411/057.03(Revised), 23 May 1989, NATO SECRET.

Air Command and Control System Master Plan, Vol. 4: Overall ACCS Design, Regional Supplement 6 - 5ATAF, Air Command and Control System Team, ACCST(87)411/057.06(Revised), 31 May 1989, NATO CONFIDENTIAL.

Air Command and Control System Master Plan, Vol. 4: Overall ACCS Design, Supporting Document 5: Quantification of Requirements, Air Command and Control System Team, ACCST(86)333/057/SD5(Revised), June 1988, NATO CONFIDENTIAL.

Air Command and Control System Master Plan, Vol. V, Phase I Transition Programme, Air Command and Control System Team, NADC(PAMCS)-D/46(PART 1), June 1989 NATO CONFIDENTIAL.

Air Command and Control System Master Plan, Vol. V, Phase I Transition Programme Supporting Document, Air Command and Control System Team, NADC(PAMCS)-D/46(PART 2), June 1989 NATO CONFIDENTIAL.

Air Command and Control System Master Plan, Vol. V, Phase I Transition Programme, Air Command and Control System Team, NADC(PAMCS)-D/46(Revised), September 1989 NATO CONFIDENTIAL.

UNCLASSIFIED

Communications and Information Systems: An Initial SHAPE Assessment of the Overall Review of the ACCS in a CFE-Limited Environment (ORACLE) - Phase I Final Report , 1209.02/SHORF/90, Supreme Headquarters, Allied Powers Europe, 22 October 1990, NATO CONFIDENTIAL.

Digital Italian Tri-Service Network (DITSN) Design Study, Presentation by Italy: Note by the Secretary, AC/317(WG/1)SG/1)N/72, North Atlantic Council, NATO Communications and Information Systems Committee, Network Rationalisation Sub-Group, 7 February 1990, NATO RESTRICTED.

Memorandum for the Chairman of ADSIA WG4 , ADSIA-RCC-C-21-90, 21 May 1990, NATO RESTRICTED.

NATO C3 Architecture , NACISA/APD/C3AB(89)101, Volumes 1-5, NACISA, 31 May 1989, NATO CONFIDENTIAL.

NATO Consultation, Command and Control (C3) Master Plan , Edition 1, AC/317-WP-66 (J-1800/77/75), Information Systems Working Group (ISWG) and Communications Systems Working Group (CSWG) of the NATO Communications and Information Systems Committee (NACISC), July 1989, NATO CONFIDENTIAL.

NTTS German Segment Presentation by Germany , North Atlantic Council, NATO Communications and Information Systems Committee, Network Rationalisation Sub-Group, 7 February 1990, NATO RESTRICTED.

NTTS Network Topology Diagram Note by the Secretary, AC/317(WG/1)N/250(Revised), North Atlantic Council, NATO Communications and Information Systems Committee, Network Rationalisation Sub-Group, 3 July 1990, NATO RESTRICTED.

NTTS System Plan , Second Edition, NACISA/APD/CSDB(90)144-D, NATO Communications and Information Systems Agency, 27 April 1990, NATO RESTRICTED.

Political Consultation and NATO Civil Emergency Planning (PCNCEP) CIS Plan , Edition 1, AC/317/(WG/1)WP/36(Revised) and AC/317(WG/2)WP/51(Revised) (J-1800/77/6), ISWG and CSWG of the NACISC, 18 July 1989, NATO CONFIDENTIAL.

Post-CFE Communications Study (a draft White Paper), NATO Communications and Information Systems Agency, 19 September 1990, NATO RESTRICTED.

Rationalisation of NATO Communications in Belgium and Luxembourg, NACISA/CSD/TTRM(90)18, NATO Communications and Information Systems Agency, 15 January 1990, NATO RESTRICTED.

Rationalisation of NATO Communications in Belgium and Luxembourg, NACISA/CSD/TTRM(90)46, NATO Communications and Information Systems Agency, 12 February 1990, NATO RESTRICTED.

Rationalisation of NATO Communications in the Netherlands, NACISA/APD/CSDB(89)392 'D,' NATO Communications and Information Systems Agency, 17 October 1989, NATO RESTRICTED.

UNCLASSIFIED

Revised NTTS Funding Profile: Note by the Secretary , AC/317(WG/1)(SG/1)N/49, North Atlantic Council, NATO Communications and Information Systems Committee, Network Rationalisation Sub-Group, 8 May 1989, NATO RESTRICTED.

SHAPE CIS Division Initial Assessment of the Post-CFE Potential Implications on the NTTS Briefing by SHAPE , AC/317(WG/1)SG/1)N/79, North Atlantic Council, NATO Communications and Information Systems Committee, Network Rationalisation Sub-Group, 14 June 1990, NATO RESTRICTED.

Statement of Work (SOW) for the Air Command and Control System (ACCS) System Specification , ACCS IMG(89)77/105.01, NATO CONFIDENTIAL.

Summary Description Report (SDR) - NTTS Belgium , AC/317(WG/1)N/155, North Atlantic Council, NATO Communications and Information Systems Committee, Communications Systems Working Group, 13 September 1988, NATO CONFIDENTIAL.

Summary Description Report for the Initial United States Participation in NTTS , AC/317(WG/1)(SG/1)N/44, North Atlantic Council, NATO Communications and Information Systems Committee, Network Rationalisation Sub-Group, 9 January 1989, NATO CONFIDENTIAL.

Summary Description Report on NTTS Italy , AC/317(WG/1)N/160, North Atlantic Council, NATO Communications and Information Systems Committee, Communications Systems Sub-Group, 25 November 1988, NATO RESTRICTED.

Summary Record - Rationalisation of NATO Communications in the Netherlands , NACISA/APD/CSDB(89)22-C, NATO Communications and Information Systems Agency, 25 January 1989, NATO RESTRICTED.

The Selection of ACCS Entities for the Post-CFE Era (Draft Annex A to SHAPE 1209.02/SHORF/90), Supreme Headquarters, Allied Powers Europe, undated, NATO RESTRICTED.

Tri-Major NATO Commanders' Command and Control (C2) Plan , 2300.12.5/SHORC/89, Edition 4, ISWG and CSWG of the NACISC, 20 July 1989, NATO SECRET.

UNCLASSIFIED

(This page intentionally left blank.)

UNCLASSIFIED

UNCLASSIFIED

APPENDIX A
TASK BACKGROUND, OBJECTIVE, AND
STATEMENT OF WORK

UNCLASSIFIED

UNCLASSIFIED

APPENDIX A
TASK BACKGROUND, OBJECTIVE, AND
STATEMENT OF WORK

This IDA Paper was written in response to Task Order T-J1-684 and Amendment No. 4. Those portions of the task order that pertain to the background, objectives, and statement of work, provided therein by the sponsoring office are reprinted here.

2. **BACKGROUND:**

To assist DoD in the determination and establishment of a U.S. preferred architecture for the NATO Air Command and Control System (ACCS), IDA conducted a multi-phase study of options for the future ACCS (1981-1987) under the basic task order. The NATO ACCS Team completed the Master Plan in 1989 which included a generic design and ten regional supplements. During 1987-89, IDA also provided detailed technical reviews and comments for a majority of the Master Plan documents. Based on national acceptance of the Master Plan, an Interim Management Group was formed in 1989 and proceeded to prepare a contract for the preparation of ACCS system specifications. In 1990, a NATO ACCS Management Agency (NACMA) was established and began to prepare for an implementation phase beginning in 1991. At the present time, NACMA is procuring System Specifications ("A-Level Specifications") based on the ACCS Master Plan. These specifications will constitute the basis for the procurement process planned to begin in 1993.

The changing international climate and threat has led to a new assessment of NATO's defense posture and operational requirements. There is general agreement that the changing political situation facing the Alliance, coupled with the reduction in military force structure resulting from the Conventional Forces Europe process will entail a reevaluation and possible reconfiguration of the proposed ACCS. The NATO funding for ACCS acquisition is primarily drawn from the infrastructure budget which is projected to decline during the next decade. National funding, which provides the remainder of the required acquisition expense has not been committed at this time.

Consequently, a major concern of the DoD is the extent to which the proposed procurement should proceed given the changed circumstances. There is an urgent need to review the procurement in order to assure compatibility with U.S. force structure, infrastructure budgetary restrictions, and revised warfighting requirements.

3. **OBJECTIVE:**

The objective of this task is an analysis of the proposed initial phase of the ACCS procurement process in order to identify alternative approaches and budget profiles.

UNCLASSIFIED

4. **STATEMENT OF WORK:**

a. **Tasks:**

Phase XII of the program in FY 1992 will consist of two tasks. The first will provide technical support to the sponsor. The second will identify and analyze ACCS procurement options.

Task 1 will: Provide technical analyses as required by the sponsor at NATO or ACCS Board of Directors meetings.

Task 2 will: Provide alternative procurement approaches to the realization of an ACCS. These approaches will be based on projected NATO expenditures considerably smaller than those currently being projected by the NACMA. Particular emphasis will be given to an analysis of existing costed options studies with a view towards further cost reductions. Specific consideration will be given to the effects of reduced levels of U.S. infrastructure contributions.

b. **Additional Guidance:**

Special attention should be given to Task 2 to the identification of procurement approaches which require less than 23% of the originally proposed cost of ACCS. The analysis may consider upgrades to the existing NATO Air Defense Ground Environment (NADGE) system as an option to a full implementation of the ACCS concept.

UNCLASSIFIED

**APPENDIX B
APPROVED DISTRIBUTION LIST FOR
IDA PAPER P-2570**

UNCLASSIFIED

UNCLASSIFIED

APPENDIX B

**APPROVED DISTRIBUTION LIST FOR
IDA PAPER P-2570**

	No. of Copies
Department of Defense	
Mr. Robert A. Giacomo Office of the Assistant Secretary of Defense, C3I Room 3D174, The Pentagon Washington, DC 20301-3040	2
Department of Defense The Joint Staff Thru Distribution Branch The Pentagon Washington, DC 20301-5000 ATTN: J6J Lt.Col. Fish	2
Defense Technical Information Center Cameron Station Alexandria, VA 22314	2
Department of the Air Force	
Department of the Air Force Office of the Deputy Chief of Staff, Plans and Operations Washington, DC 20330-5057 ATTN: Lt.Col. Boyd Nix (XOOTT) Room BF 881	3
NATO	
Mr. Thomas Kuntz U.S. Mission NATO PSC 81 APO AE 09724	10
MajGen William MacLaren (USAF, Ret.) NACMA Rue de Geneve, 8 1140 Brussels, Belgium	4

UNCLASSIFIED

NATO Headquarters
International Staff, Division of Defense Support
C3 Directorate
B-1110 Brussels, Belgium
 ATTN: Dr. Andreas Rannestad (ICP Section) 1
 David A. Facey (Air Defense Systems Directorate) 1
 Communications and Information Systems Division 2

NACSLA
Rue de Geneve, 8
1140 Brussels, Belgium
 ATTN: Mr. Murzi 1

SHAPE
CISD Division
B-7010 Mons, Belgium
 ATTN: WG. CDR W.C. Griffiths 4

Other Organizations

Institute for Defense Analyses
1801 N. Beauregard St.
Alexandria, VA 22311 15